

Methods in
Molecular Biology 1404

Springer Protocols

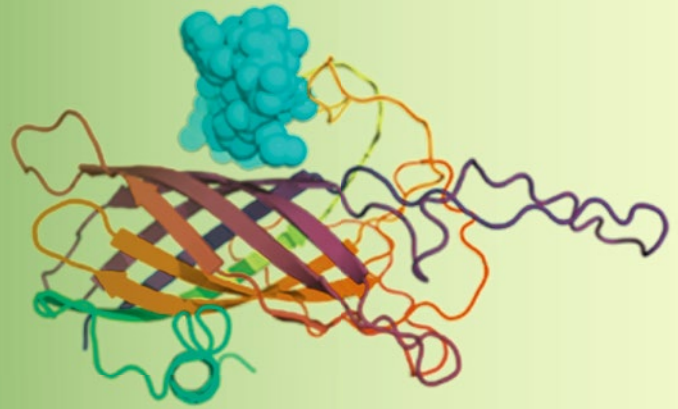

Sunil Thomas *Editor*

Vaccine Design

Methods and Protocols

Volume 2:

Vaccines for Veterinary Diseases

 Humana Press

METHODS IN MOLECULAR BIOLOGY

Series Editor

John M. Walker

School of Life and Medical Sciences

University of Hertfordshire

Hatfield, Hertfordshire, AL10 9AB, UK

For further volumes:

<http://www.springer.com/series/7651>

Vaccine Design

Methods and Protocols, Volume 2: Vaccines for Veterinary Diseases

Edited by

Sunil Thomas

Lankenau Institute for Medical Research, Wynnewood, PA, USA

 **Humana Press**

Editor

Sunil Thomas
Lankenau Institute for Medical Research
Wynnewood, PA, USA

ISSN 1064-3745 ISSN 1940-6029 (electronic)
Methods in Molecular Biology
ISBN 978-1-4939-3388-4 ISBN 978-1-4939-3389-1 (eBook)
DOI 10.1007/978-1-4939-3389-1

Library of Congress Control Number: 2016934046

Springer New York Heidelberg Dordrecht London
© Springer Science+Business Media New York 2016

This work is subject to copyright. All rights are reserved by the Publisher, whether the whole or part of the material is concerned, specifically the rights of translation, reprinting, reuse of illustrations, recitation, broadcasting, reproduction on microfilms or in any other physical way, and transmission or information storage and retrieval, electronic adaptation, computer software, or by similar or dissimilar methodology now known or hereafter developed.

The use of general descriptive names, registered names, trademarks, service marks, etc. in this publication does not imply, even in the absence of a specific statement, that such names are exempt from the relevant protective laws and regulations and therefore free for general use.

The publisher, the authors and the editors are safe to assume that the advice and information in this book are believed to be true and accurate at the date of publication. Neither the publisher nor the authors or the editors give a warranty, express or implied, with respect to the material contained herein or for any errors or omissions that may have been made.

Printed on acid-free paper

Humana Press is a brand of Springer
Springer Science+Business Media LLC New York is part of Springer Science+Business Media (www.springer.com)

Dedication

Dedicated to:

Vaccinologists (who work hard developing vaccines) and

Healthcare workers in developing countries (who risk their lives vaccinating people)

Preface

“We are protecting children from polio at the cost of our lives.”—
Sabeeha Begum (a lady healthcare worker providing polio vaccines in
Quetta, Pakistan)

Vaccinations have helped in preventing several diseases; however, as yet, there are only two diseases that have been eradicated globally. Mass awareness programs and aggressive vaccination strategies in the twentieth century were able to control smallpox, and the disease was officially declared eradicated in 1980. Rinderpest, a serious disease of cattle, was officially eradicated in 2011, thereby becoming only the second disease to be completely eradicated. Recently, the Americas (North and South America) were declared free of endemic transmission of rubella, a contagious viral disease that can cause multiple birth defects as well as fetal death when contracted by women during pregnancy. The achievement was due to a 15-year effort that involved widespread administration of the vaccine against measles, mumps, and rubella (MMR) throughout the Western Hemisphere.

One of the dreaded diseases—poliomyelitis—is in the last phases of eradication, thanks to the effective vaccines against the disease. The public health effort to eliminate poliomyelitis infection around the world began in 1988, and vaccination strategies have reduced the number of annual diagnosed cases of polio from the hundreds of thousands to couple of hundreds. Nigeria was the last country in Africa to eradicate polio; as of writing this book, no polio is reported in Nigeria since last year. Currently, polio remains endemic in two countries—Afghanistan and Pakistan. Until poliovirus transmission is interrupted in these countries, all other countries remain at risk of importation of polio. Illiteracy, ignorance to vaccines, death threats, as well as killing of healthcare workers providing polio vaccines have slowed immunization programs in Pakistan. This toxic scenario coupled with the migration of people has led to the persistence of polio in Pakistan and neighboring Afghanistan. With awareness for the need of vaccination, knowledge on the importance of vaccination, and new rules that may penalize resistance to vaccination, it may be possible to eliminate polio by the end of the decade.

When I was given the opportunity to author this book (*Vaccine Design: Methods and Protocols*), I wished to have at least one chapter on vaccine design or vaccine development from every country. Unfortunately, it dawned on me later that not every country invests in science! It was also unfortunate to realize that research and development on vaccines is not a priority even in some developed countries with resources or influence. New sustainable technologies are to be developed to create more jobs and improve the well-being of humans as well as conservation of nature; hence it is high time countries invest at least 5 % of their GDP for science including vaccine development.

Vaccine Design: Methods and Protocols is a practical guide providing step-by-step protocol to design and develop vaccines. The purpose of the book is to help vaccinologists develop novel vaccines for diseases that are yet to have vaccines based on currently available vaccination protocols and strategies. The book will provide protocols for developing novel vaccines against infectious bacteria, viruses, and parasites for humans and animals as well as

vaccines for cancer, allergy, and substance abuse. The book also contains chapters on how antigenic proteins for vaccines should be selected and designed in silico, vectors for producing recombinant antigenic proteins, and the production of antigenic proteins in plant systems. Most vaccinologists are not aware of the intellectual property (IP) of vaccines, the importance of patents before commercialization, and what components of vaccines could be patented; hence chapters on these aspects are also included in the book. The book also contains a chapter on the regulatory evaluation and testing requirements for vaccines.

The *Methods in Molecular Biology*[™] series *Vaccine Design: Methods and Protocols* contains 103 chapters in two volumes. Volume 1, *Vaccines for Human Diseases*, has an introductory section on how vaccines impact diseases, the immunological mechanism of vaccines, and future challenges for vaccinologists and current trends in vaccinology. The design of human vaccines for viral, bacterial, fungal, parasitic, and prion diseases as well as vaccines for drug abuse, allergy, and tumor are also described in this volume. Volume 2, *Vaccines for Veterinary Diseases*, includes vaccines for farm animals and fishes, vaccine vectors and production, vaccine delivery systems, vaccine bioinformatics, vaccine regulation, and intellectual property.

It has been 220 years since Edward Jenner vaccinated his first patient in 1796. This book is a tribute to the pioneering effort of his work. My sincere thanks to all the authors for contributing to *Vaccine Design: Methods and Protocols* Volume 1 (*Vaccines for Human Diseases*) and Volume 2 (*Vaccines for Veterinary Diseases*). The book would not have materialized without the effort of authors from all over the world. I would also like to thank the series editor of *Methods in Molecular Biology*[™], Prof. John M. Walker, for giving me the opportunity to edit this book. My profound thanks to my wife Jyothi, for the encouragement and support, and also to our twins—Teresa and Thomas—for patiently waiting for me while editing this book. Working on the book was not an excuse for missing story time, and I made sure that you were told a couple of stories every day before bedtime.

Wynnewood, PA, USA

Sunil Thomas

Contents

<i>Preface</i>	<i>vii</i>
<i>Contributors</i>	<i>xv</i>
PART I CHALLENGES IN VETERINARY VACCINE DEVELOPMENT	
1 Challenges in Veterinary Vaccine Development and Immunization <i>Mark A. Chambers, Simon P. Graham, and Roberto M. La Ragione</i>	3
PART II VACCINES FOR FARM ANIMALS	
2 Development of <i>Mycoplasma hyopneumoniae</i> Recombinant Vaccines <i>Silvana Bentinger Marchioro, Simone Simionatto, and Odir Dellagostin</i>	39
3 Computational Prediction of Immunodominant Epitopes on Outer Membrane Protein (Omp) H of <i>Pasteurella multocida</i> Toward Designing of a Peptide Vaccine <i>Bhaskar Ganguly</i>	51
4 DNA Vaccines Against Maedi–Visna Virus <i>Ana M. Henriques, Miguel Fevereiro, and Gabriel A. Monteiro</i>	59
5 Detection of Avian Antigen-Specific T Cells Induced by Viral Vaccines <i>Tina Sørensen Dalgaard, Liselotte Rothmann Norup, and Helle Risdahl Juul-Madsen</i>	77
6 Generation of Newcastle Disease Virus (NDV) Recombinants Expressing the Infectious Laryngotracheitis Virus (ILTV) Glycoprotein gB or gD as Dual Vaccines <i>Wei Zhao, Stephen Spatz, Laszlo Zsak, and Qingzhong Yu</i>	89
7 A Reverse Genetics Approach for the Design of Methyltransferase-Defective Live Attenuated Avian Metapneumovirus Vaccines <i>Yu Zhang, Jing Sun, Yongwei Wei, and Jianrong Li</i>	103
8 Development of Fasciola Vaccine in an Animal Model <i>Krai Meemon and Prasert Sobhon</i>	123
9 Development of Experimental Vaccines Against Liver Flukes <i>Huan Yong Yap and Peter M. Smooker</i>	135
10 Towards a Preventive Strategy for Toxoplasmosis: Current Trends, Challenges, and Future Perspectives for Vaccine Development. <i>Ragab M. Fereig and Yoshifumi Nishikawa</i>	153
11 DNA Vaccination in Chickens <i>Shishir Kumar Gupta, Sohini Dey, and Madhan Mohan Chellappa</i>	165

PART III VACCINES FOR FISHES AND SHELLFISH

12	Selection of Vaccine Candidates for Fish Pasteurellosis Using Reverse Vaccinology and an In Vitro Screening Approach	181
	<i>Francesca Andreoni, Giulia Amagliani, and Mauro Magnani</i>	
13	Development of Vaccines Against Nocardiosis in Fishes	193
	<i>Sukanta K. Nayak and Teruyuki Nakanishi</i>	
14	Design of an Immersion Vaccine Against Aeromonad Septicemia in Perch (<i>Perca fluviatilis</i> L.)	203
	<i>Joachim Frey, Sarah E. Burr, and Thomas Wahli</i>	
15	Prokaryotic Production of Virus-Like Particle Vaccine of Betanodavirus	211
	<i>Junfeng Xie, Runqing Huang, and Yuxiong Lai</i>	
16	Design and Construction of Shrimp Antiviral DNA Vaccines Expressing Long and Short Hairpins for Protection by RNA Interference	225
	<i>Aparna Chaudhari, Gireesh-Babu Pathakota, and Pavan-Kumar Annam</i>	

PART IV VACCINES AGAINST TICKS

17	Developing Anti-tick Vaccines	243
	<i>Alina Rodríguez-Mallon</i>	
18	Host Immunization with Recombinant Proteins to Screen Antigens for Tick Control	261
	<i>Remil Linggatong Galay, Takeshi Miyata, Rika Umemiya-Shirafuji, Masami Mochizuki, Kozo Fujisaki, and Tetsuya Tanaka</i>	
19	Vaccinomics Approach to Tick Vaccine Development	275
	<i>Marinela Contreras, Margarita Villar, Pilar Alberdi, and José de la Fuente</i>	

PART V VACCINE ADJUVANTS

20	Development of CpG ODN Based Vaccine Adjuvant Formulations	289
	<i>Mayda Gursel and Ihsan Gursel</i>	

PART VI VACCINE VECTORS AND PRODUCTION SYSTEMS

21	Assembly and Assessment of DNA Scaffolded Vaccines	301
	<i>Xiaowei Liu, Lili Wang, Hao Yan, and Yung Chang</i>	
22	Alphavirus-Based Vaccines	313
	<i>Kenneth Lundstrom</i>	
23	Vaccine Design: Replication-Defective Adenovirus Vectors	329
	<i>Xiangyang Zhou, Zhiquan Xiang, and Hildegund C.J. Ertl</i>	
24	Generation of Lymphocytic Choriomeningitis Virus Based Vaccine Vectors	351
	<i>Sandra Ring and Lukas Flatz</i>	
25	Production of Japanese Encephalitis Virus-Like Particles Using Insect Cell Expression Systems	365
	<i>Hideki Yamaji and Eiji Konishi</i>	

26	Subunit Protein Vaccine Delivery System for Tuberculosis Based on Hepatitis B Virus Core VLP (HBc-VLP) Particles	377
	<i>Dhananjayan Dhanasoora, R. Ajay Kumar, and Sathish Mundayoor</i>	
27	Formulation Studies During Preclinical Development of Influenza Hemagglutinin and Virus-Like Particle Vaccine Candidates	393
	<i>Newton Wahome, John M. Hickey, David B. Volkin, and C. Russell Middaugh</i>	
28	Strategies for Vaccine Design Using Phage Display-Derived Peptides	423
	<i>Luiz R. Goulart and Paula de S. Santos</i>	
29	Production of Well-Characterized Virus-like Particles in an <i>Escherichia coli</i> -Based Expression Platform for Preclinical Vaccine Assessments	437
	<i>Newton Wahome, Anne Cooper, Prem Thapa, Shyamal Choudhari, Fei P. Gao, David B. Volkin, and C. Russell Middaugh</i>	
30	Laboratory Scale Production of Recombinant Haa86 Tick Protein in <i>Pichia pastoris</i> and in <i>Escherichia coli</i> System	459
	<i>Binod Kumar, Azhabianambi P., and Srikant Ghosh</i>	
31	Production and Purification of Recombinant Filamentous Bacteriophages Displaying Immunogenic Heterologous Epitopes	483
	<i>Lei Deng, Florencia Linero, and Xavier Saelens</i>	
32	Oral Vaccine Development by Molecular Display Methods Using Microbial Cells	497
	<i>Seiji Shibasaki and Mitsuyoshi Ueda</i>	
33	Facile Method for the Production of Recombinant Cholera Toxin B Subunit in <i>E. coli</i>	511
	<i>Krystal Hamorsky and Nobuyuki Matoba</i>	
34	Immunoproteomic Approach for Screening Vaccine Candidates from Bacterial Outer Membrane Proteins	519
	<i>Jianyi Pan, Chuchu Li, and Zhicang Ye</i>	
35	Construction and Immunogenicity Testing of Whole Recombinant Yeast-Based T-Cell Vaccines	529
	<i>Thomas H. King, Zhimin Guo, Melanie Hermreck, Donald Bellgrau, and Timothy C. Rodell</i>	
36	Oral Rabies Vaccine Design for Expression in Plants	547
	<i>Ankit Singh, Gauri Saxena, and Praveen C. Verma</i>	
37	Purification of Virus-Like Particles (VLPs) from Plants	569
	<i>Albertha R. van Zyl and Inga I. Hitzeroth</i>	
38	Transient Expression of Viral Proteins in Plants Using <i>Agrobacterium tumefaciens</i>	581
	<i>Inga I. Hitzeroth and Albertha R. van Zyl</i>	
39	A Plant-Based Transient Expression System for the Rapid Production of Malaria Vaccine Candidates	597
	<i>Alexander Boes, Andreas Reimann, Richard M. Twyman, Rainer Fischer, Stefan Schillberg, and Holger Spiegel</i>	

40	Recombinant Botulinum Toxoids: A Practical Guide for Production	621
	<i>Gustavo Marçal S.G. Moreira, Clóvis Moreira Jr., Carlos Eduardo P. da Cunha, Marcelo Mendonça, and Fabricio R. Conceição</i>	

PART VII VACCINE DELIVERY SYSTEMS

41	Preparation of Multifunctional Liposomes as a Stable Vaccine Delivery-Adjuvant System by Procedure of Emulsification-Lyophilization	635
	<i>Ning Wang and Ting Wang</i>	
42	Preparation of the Multifunctional Liposome-Containing Microneedle Arrays as an Oral Cavity Mucosal Vaccine Adjuvant-Delivery System	651
	<i>Ting Wang and Ning Wang</i>	
43	Preparation and Characterization of PLGA Encapsulated Protective Antigen Domain 4 Nanoformulation	669
	<i>Manish Manish, Rakesh Bhatnagar, and Samer Singh</i>	
44	Attenuated <i>Salmonella</i> sp. as a DNA Delivery System for <i>Trypanosoma cruzi</i> Antigens.	683
	<i>Augusto E. Bivona, Natacha Cerny, Andrés Sánchez Alberti, Silvia I. Cazorla, and Emilio L. Malchiodi</i>	
45	Poly-ε-caprolactone/Chitosan and Chitosan Particles: Two Recombinant Antigen Delivery Systems for Intranasal Vaccination.	697
	<i>Sandra Jesus, Edna Soares, and Olga Borges</i>	
46	Micro-fractional Epidermal Powder Delivery for Skin Vaccination	715
	<i>Feng Jia, Shengwu Liu, Mei X. Wu, and Xinyuan Chen</i>	

PART VIII VACCINE BIOINFORMATICS

47	A Bioinformatics Method for the Design of Live Attenuated Virus Vaccine Utilizing Host MicroRNA Response Elements	727
	<i>Duangdao Wichadakul</i>	
48	The Web-Based DNA Vaccine Database DNAVaxDB and Its Usage for Rational DNA Vaccine Design	741
	<i>Rebecca Racz and Yongqun He</i>	
49	MetaMHCpan, A Meta Approach for Pan-Specific MHC Peptide Binding Prediction	753
	<i>Yichang Xu, Cheng Luo, Hiroshi Mamitsuka, and Shanfeng Zhu</i>	
50	A Cohesive and Integrated Platform for Immunogenicity Prediction	761
	<i>Ivan Dimitrov, Mariyana Atanasova, Atanas Patronov, Darren R. Flower, and Irini Doytchinova</i>	

PART IX VACCINE SAFETY AND REGULATION

51	The Regulatory Evaluation of Vaccines for Human Use.	773
	<i>Norman W. Baylor</i>	

PART X VACCINE INTELLECTUAL PROPERTY

52	Vaccines and IP Rights: A Multifaceted Relationship	791
	<i>Karen Durell</i>	
53	From the Bench to the Pharmacy: Protecting Innovation During Vaccine Development and Commercialization	813
	<i>Adam C. Krol, Muna Abu-Shaar, and Paul Brady</i>	
54	Intellectual Property in Vaccine Innovation: Impact of Recent Patent Developments	835
	<i>Elizabeth Siew-Kuan Ng</i>	
	<i>Index</i>	849

Contributors

- SEPIDEH ABOUTORABIAN • *Bioprocess Research and Development, Toronto, ON, Canada*
- MUNA ABU-SHAAR • *Biospark Intellectual Property Law, Cambridge, MA, USA*
- PILAR ALBERDI • *SaBio, Instituto de Investigación en Recursos Cinegéticos IREC-CSIC-UCLM-JCCM, Ronda de Toledo s/n, Ciudad Real, Spain*
- ANDRÉS SÁNCHEZ ALBERTI • *Cátedra de Inmunología and Instituto de Estudios de la Inmunidad Humoral (IDEHU), CONICET-UBA, Facultad de Farmacia y Bioquímica, Universidad de Buenos Aires, Buenos Aires, Argentina; Instituto de Microbiología y Parasitología Médica, IMPaM (UBA-CONICET) y Departamento de Microbiología, Parasitología e Inmunología, Facultad de Medicina, Universidad de Buenos Aires, Buenos Aires, Argentina*
- GIULIA AMAGLIANI • *Department of Biomolecular Science—Section of Biotechnology, University of Urbino “Carlo Bo”, Fano, Italy*
- FRANCESCA ANDREONI • *Department of Biomolecular Science—Section of Biotechnology, University of Urbino “Carlo Bo”, Fano, Italy*
- PAVAN-KUMAR ANNAM • *ICAR-Central Institute of Fisheries Education, Mumbai, India*
- MARIYANA ATANASOVA • *School of Pharmacy, Medical University of Sofia, Sofia, Bulgaria*
- SALVADOR F. AUSAR • *Bioprocess Research and Development, Toronto, ON, Canada*
- AZHAHIANAMBI P. • *Entomology Laboratory, Parasitology Division, Indian Veterinary Research Institute, Bareilly, Uttar Pradesh, India; Department of Veterinary Parasitology, Madras Veterinary College, Chennai, Tamil Nadu, India*
- GIREESH-BABU PATHAKOTA • *ICAR-Central Institute of Fisheries Education, Mumbai, India*
- NORMAN W. BAYLOR • *Biologics Consulting Group, Inc., Alexandria, VA, USA*
- DONALD BELLGRAU • *GlobeImmune, Inc., Louisville, CO, USA; Integrated Department of Immunology, University of Colorado School of Medicine, Aurora, CO, USA*
- RAKESH BHATNAGAR • *Laboratory of Molecular Biology and Genetic Engineering, School of Biotechnology, Jawaharlal Nehru University, New Delhi, India*
- AUGUSTO E. BIVONA • *Cátedra de Inmunología and Instituto de Estudios de la Inmunidad Humoral (IDEHU), CONICET-UBA, Facultad de Farmacia y Bioquímica, Universidad de Buenos Aires, Buenos Aires, Argentina; Instituto de Microbiología y Parasitología Médica, IMPaM (UBA-CONICET) y Departamento de Microbiología, Parasitología e Inmunología, Facultad de Medicina, Universidad de Buenos Aires, Buenos Aires, Argentina; Laboratorio de Inmunología, Departamento Ciencias Básicas-INEDES (UNLu-CONICET), Universidad Nacional de Luján, Luján, Argentina*
- ALEXANDER BOES • *Fraunhofer Institute for Molecular Biology and Applied Ecology IME, Aachen, Germany*
- OLGA BORGES • *Center for Neuroscience and Cell Biology, University of Coimbra, Coimbra, Portugal; Faculty of Pharmacy, University of Coimbra, Coimbra, Portugal*
- PAUL BRADY • *Abel and Imray, London, UK*
- SARAH E. BURR • *Institute of Veterinary Bacteriology, Vetsuisse, University of Bern, Bern, Switzerland; Clinical Research Department, London School of Hygiene and Tropical Medicine, London, UK*

- SILVIA I. CAZORLA • *Cátedra de Inmunología and Instituto de Estudios de la Inmunidad Humoral (IDEHU), CONICET-UBA, Facultad de Farmacia y Bioquímica, Universidad de Buenos Aires, Buenos Aires, Argentina; Instituto de Microbiología y Parasitología Médica, IMPaM (UBA-CONICET) y Departamento de Microbiología, Parasitología e Inmunología, Facultad de Medicina, Universidad de Buenos Aires, Buenos Aires, Argentina*
- NATACHA CERNY • *Cátedra de Inmunología and Instituto de Estudios de la Inmunidad Humoral (IDEHU), CONICET-UBA, Facultad de Farmacia y Bioquímica, Universidad de Buenos Aires, Buenos Aires, Argentina; Instituto de Microbiología y Parasitología Médica, IMPaM (UBA-CONICET) y Departamento de Microbiología, Parasitología e Inmunología, Facultad de Medicina, Universidad de Buenos Aires, Buenos Aires, Argentina; Laboratorio de Inmunología, Departamento Ciencias Básicas- INEDES (UNLu-CONICET), Universidad Nacional de Luján, Luján, Argentina*
- MARK A. CHAMBERS • *Department of Pathology and Infectious Diseases, School of Veterinary Medicine, University of Surrey, Guildford, Surrey, UK; Department of Bacteriology, Animal and Plant Health Agency, Surrey, UK*
- YUNG CHANG • *Center of Infectious Disease and Vaccinology, The Biodesign Institute, Arizona State University, Tempe, AZ, USA; School of Life Sciences, Arizona State University, Tempe, AZ, USA*
- APARNA CHAUDHARI • *ICAR-Central Institute of Fisheries Education, Mumbai, India*
- MADHAN MOHAN CHELLAPPA • *Division of Veterinary Biotechnology, Indian Veterinary Research Institute, Bareilly, India*
- XINYUAN CHEN • *Wellman Center for Photomedicine, Massachusetts General Hospital, Department of Dermatology, Harvard Medical School, Boston, MA, USA; Biomedical and Pharmaceutical Sciences, College of Pharmacy, University of Rhode Island, Kingston, RI, USA*
- SHYAMAL CHOUDHARI • *Department of Pharmaceutical Chemistry, Macromolecule and Vaccine Stabilization Center, University of Kansas, Lawrence, KS, USA*
- FABRICIO R. CONCEIÇÃO • *Laboratório de Imunologia Aplicada, Núcleo de Biotecnologia, Centro de Desenvolvimento Tecnológico, Universidade Federal de Pelotas, Pelotas, Brazil*
- MARINELA CONTRERAS • *SaBio, Instituto de Investigación en Recursos Cinegéticos IREC-CSIC-UCLM-JCCM, Ronda de Toledo s/n, Ciudad Real, Spain*
- ANNE COOPER • *Protein Production Group, University of Kansas, Lawrence, KS, USA*
- CARLOS EDUARDO P. DA CUNHA • *Laboratório de Imunologia Aplicada, Núcleo de Biotecnologia, Centro de Desenvolvimento Tecnológico, Universidade Federal de Pelotas, Pelotas, Brazil*
- TINA SØRENSEN DALGAARD • *Department of Animal Science, Aarhus University, Tjele, Denmark*
- ODIR DELLAGOSTIN • *Centro de Desenvolvimento Tecnológico, Universidade Federal de Pelotas, Pelotas, RS, Brazil*
- LEI DENG • *Department of Biomedical Molecular Biology, Ghent University, Ghent, Belgium; Medical Biotechnology Center, VIB, Ghent, Belgium*
- SOHINI DEY • *Division of Veterinary Biotechnology, Indian Veterinary Research Institute, Bareilly, India*
- DHANANJAYAN DHANASOORAJ • *Mycobacteria Research, Rajiv Gandhi Centre for Biotechnology, Thiruvananthapuram, Kerala, India*
- IVAN DIMITROV • *School of Pharmacy, Medical University of Sofia, Sofia, Bulgaria*

- IRINI DOYTCHINOVA • *School of Pharmacy, Medical University of Sofia, Sofia, Bulgaria*
- KAREN DURELL • *Miller Thomson, LLP, Toronto, ON, Canada*
- HILDEGUND C.J. ERTL • *The Wistar Institute, Philadelphia, PA, USA*
- RAGAB M. FERREIG • *National Research Center for Protozoan Diseases, Obihiro University of Agriculture and Veterinary Medicine, Obihiro, Hokkaido, Japan*
- MIGUEL FEVEREIRO • *Laboratory of Virology, Instituto Nacional de Investigação Agrária e Veterinária, Lisbon, Portugal*
- RAINER FISCHER • *Fraunhofer Institute for Molecular Biology and Applied Ecology IME, Aachen, Germany; Institute for Molecular Biotechnology, RWTH Aachen University, Aachen, Germany*
- LUKAS FLATZ • *Institute of Immunobiology, Kantonsspital St. Gallen, St. Gallen, Switzerland*
- DARREN R. FLOWER • *School of Life and Health Sciences, Aston University, Birmingham, UK*
- JOACHIM FREY • *Institute of Veterinary Bacteriology, Vetsuisse, University of Bern, Bern, Switzerland*
- JOSÉ DE LA FUENTE • *SaBio, Instituto de Investigación en Recursos Cinegéticos IREC-CSIC-UCLM-JCCM, Ronda de Toledo s/n, Ciudad Real, Spain; Department of Veterinary Pathobiology, Center for Veterinary Health Sciences, Oklahoma State University, Stillwater, OK, USA*
- KOZO FUJISAKI • *National Agricultural and Food Research Organization, Tsukuba, Ibaraki, Japan*
- REMIL LINGGATONG GALAY • *Laboratory of Infectious Diseases, Joint Faculty of Veterinary Medicine, Kagoshima University, Kagoshima, Japan*
- BHASKAR GANGULY • *Animal Biotechnology Center, Department of Veterinary Physiology and Biochemistry, College of Veterinary and Animal Sciences, G. B. Pant University of Agriculture and Technology, Pantnagar, Uttarakhand, India*
- FEI P. GAO • *Protein Production Group, University of Kansas, Lawrence, KS, USA*
- SRIKANT GHOSH • *Entomology Laboratory, Parasitology Division, Indian Veterinary Research Institute, Izatnagar, Bareilly, Uttar Pradesh, India*
- LUIZ R. GOULART • *Laboratory of Nanobiotechnology, Institute of Genetics and Biochemistry, Federal University of Uberlândia, Uberlândia, MG, Brazil*
- SIMON P. GRAHAM • *Department of Pathology and Infectious Diseases, School of Veterinary Medicine, University of Surrey, Guildford, Surrey, UK; The Pirbright Institute, Woking, UK*
- ZHIMIN GUO • *GlobeImmune, Inc., Louisville, CO, USA*
- SHISHIR KUMAR GUPTA • *Division of Veterinary Biotechnology, Indian Veterinary Research Institute, Bareilly, India*
- IHSAN GURSEL • *THORLAB-Therapeutic Oligonucleotide Research Laboratory, Department of Molecular Biology and Genetics, Bilkent University, Ankara, Turkey*
- MAYDA GURSEL • *Department of Biological Sciences, Middle East Technical University, Ankara, Turkey*
- KRYSTAL HAMORSKY • *Owensboro Cancer Research Program, University of Louisville James Graham Brown Cancer Center, Owensboro, KY, USA; Department of Medicine, University of Louisville School of Medicine, Louisville, KY, USA*
- NOBUYUKI MATOBA • *Owensboro Cancer Research Program, University of Louisville James Graham Brown Cancer Center, Owensboro, KY, USA; Department of Pharmacology and Toxicology, University of Louisville School of Medicine, Louisville, KY, USA*
- MANVI HASIJA • *Bioprocess Research and Development, Toronto, ON, Canada*

- YONGQUN HE • *Unit for Laboratory Animal Medicine, University of Michigan Medical School, Ann Arbor, MI, USA; Department of Microbiology and Immunology, University of Michigan Medical School, Ann Arbor, MI, USA; Center for Computational Medicine and Bioinformatics, University of Michigan Medical School, Ann Arbor, MI, USA; Comprehensive Cancer Center, University of Michigan Medical School, Ann Arbor, MI, USA*
- ANA M. HENRIQUES • *Laboratory of Virology, Instituto Nacional de Investigação Agrária e Veterinária, Lisbon, Portugal*
- MELANIE HERMRECK • *GlobeImmune, Inc., Louisville, CO, USA*
- JOHN M. HICKEY • *Department of Pharmaceutical Chemistry, Macromolecule and Vaccine Stabilization Center, University of Kansas, Lawrence, KS, USA*
- INGA I. HITZEROTH • *Biopharming Research Unit, Department of Molecular and Cell Biology, University of Cape Town, Rondebosch, South Africa*
- RUNQING HUANG • *State Key Laboratory of Biocontrol, School of Life Sciences, Sun Yat-sen University, Guangzhou, China; MOE Key Laboratory of Aquatic Product Safety, School of Marine Sciences, Sun Yat-sen University, Guangzhou, China; Institute of Aquatic Economic Animals, School of Life Sciences, Sun Yat-sen University, Guangzhou, China; Guangdong Province Key Laboratory for Aquatic Economic Animals, School of Life Sciences, Sun Yat-sen University, Guangzhou, China*
- SANDRA JESUS • *Center for Neuroscience and Cell Biology, University of Coimbra, Coimbra, Portugal; Faculty of Pharmacy, University of Coimbra, Coimbra, Portugal*
- FENG JIA • *Wellman Center for Photomedicine, Massachusetts General Hospital, Department of Dermatology, Harvard Medical School, Boston, MA, USA*
- HELLE RISDAHL JUUL-MADSEN • *Department of Animal Science, Aarhus University, Tjele, Denmark*
- THOMAS H. KING • *GlobeImmune, Inc., Louisville, CO, USA*
- EIJI KONISHI • *BIKEN Endowed Department of Dengue Vaccine Development, Faculty of Tropical Medicine, Mahidol University, Bangkok, Thailand; BIKEN Endowed Department of Dengue Vaccine Development, Research Institute for Microbial Diseases, Osaka University, Suita, Japan*
- ADAM C. KROL • *Biospark Intellectual Property Law, Cambridge, MA, USA*
- BINOD KUMAR • *Entomology Laboratory, Parasitology Division, Indian Veterinary Research Institute, Izatnagar, Bareilly, Uttar Pradesh, India; Department of Veterinary Parasitology, College of Veterinary Science and Animal Husbandry, Junagadh Agricultural University, Junagadh, Gujarat, India*
- R. AJAY KUMAR • *Mycobacteria Research, Rajiv Gandhi Centre for Biotechnology, Thiruvananthapuram, Kerala, India*
- YUXIONG LAI • *State Key Laboratory of Biocontrol, School of Life Sciences, Sun Yat-sen University, Guangzhou, China; MOE Key Laboratory of Aquatic Product Safety, School of Marine Sciences, Sun Yat-sen University, Guangzhou, China; Institute of Aquatic Economic Animals, School of Life Sciences, Sun Yat-sen University, Guangzhou, China; Guangdong Province Key Laboratory for Aquatic Economic Animals, School of Life Sciences, Sun Yat-sen University, Guangzhou, China*
- CHUCHU LI • *Institute of Proteomics and Molecular Enzymology, School of Life Sciences, Zhejiang Sci-Tech University, Hangzhou, China*
- JIANRONG LI • *Department of Veterinary Biosciences, College of Veterinary Medicine, The Ohio State University, Columbus, OH, USA*
- FLORENCIA LINERO • *Department of Biomedical Molecular Biology, Ghent University, Ghent, Belgium; Medical Biotechnology Center, VIB, Ghent, Belgium*

- SHENGWU LIU • *Wellman Center for Photomedicine, Massachusetts General Hospital, Department of Dermatology, Harvard Medical School, Boston, MA, USA*
- XIAOWEI LIU • *Center for Infectious Diseases and Vaccinology, The Biodesign Institute, Arizona State University, Tempe, AZ, USA*
- KENNETH LUNDSTROM • *PanTherapeutics, Lutry, Switzerland*
- CHENG LUO • *School of Computer Science, Fudan University, Shanghai, China; Shanghai Key Lab of Intelligent Information Processing, Fudan University, Shanghai, China*
- MAURO MAGNANI • *Department of Biomolecular Science—Section of Biotechnology, University of Urbino “Carlo Bo”, Fano, Italy*
- EMILIO L. MALCHIODI • *Cátedra de Inmunología and Instituto de Estudios de la Inmunidad Humoral (IDEHU), CONICET-UBA, Facultad de Farmacia y Bioquímica, Universidad de Buenos Aires, Buenos Aires, Argentina; Instituto de Microbiología y Parasitología Médica, IMPaM (UBA-CONICET) y Departamento de Microbiología, Parasitología e Inmunología, Facultad de Medicina, Universidad de Buenos Aires, Buenos Aires, Argentina*
- HIROSHI MAMITSUKA • *Bioinformatics Center, Institute for Chemical Research, Kyoto University, Kyoto, Japan*
- MANISH MANISH • *Laboratory of Molecular Biology and Genetic Engineering, School of Biotechnology, Jawaharlal Nehru University, New Delhi, India; Department of Biosciences, Manipal University Jaipur, Rajasthan, India*
- SILVANA BEUTINGER MARCHIORO • *Faculdade de Ciências da Saúde, Universidade Federal da Grande Dourados, Rodovia Dourados – Cidade Universitaria, Cx., Dourados, MS, Brazil*
- KRAI MEEMON • *Department of Anatomy, Faculty of Science, Mahidol University, Bangkok, Thailand*
- MARCELO MENDONÇA • *Laboratório de Imunologia Aplicada, Núcleo de Biotecnologia, Centro de Desenvolvimento Tecnológico, Universidade Federal de Pelotas, Pelotas, Brazil*
- C. RUSSELL MIDDGAUGH • *Department of Pharmaceutical Chemistry, Macromolecule and Vaccine Stabilization Center, University of Kansas, Lawrence, KS, USA*
- TAKESHI MIYATA • *Laboratory of Food Chemistry, Division of Molecular Functions of Food, Department of Biochemistry and Biotechnology, Faculty of Agriculture, Kagoshima University, Kagoshima, Japan*
- MASAMI MOCHIZUKI • *Laboratory of Infectious Diseases, Joint Faculty of Veterinary Medicine, Kagoshima University, Kagoshima, Japan*
- GABRIEL A. MONTEIRO • *Institute for Bioengineering and Biosciences, Instituto Superior Técnico, Lisbon, Portugal; Department of Bioengineering, Instituto Superior Técnico, Lisbon, Portugal*
- GUSTAVO MARÇAL S.G. MOREIRA • *Laboratório de Imunologia Aplicada, Núcleo de Biotecnologia, Centro de Desenvolvimento Tecnológico, Universidade Federal de Pelotas, Pelotas, Brazil*
- CLÓVIS MOREIRA JR. • *Laboratório de Imunologia Aplicada, Núcleo de Biotecnologia, Centro de Desenvolvimento Tecnológico, Universidade Federal de Pelotas, Pelotas, Brazil*
- SATHISH MUNDAYOOR • *Mycobacteria Research, Rajiv Gandhi Centre for Biotechnology, Thiruvananthapuram, Kerala, India*
- TERUYUKI NAKANISHI • *Department of Veterinary Medicine, College of Bioresource Sciences, Nihon University, Fujisawa, Japan*
- SUKANTA K. NAYAK • *Department of Biotechnology, North Orissa University, Baripada, India*

- ELIZABETH SIEW-KUAN NG • *Faculty of Law, National University of Singapore, Singapore, Singapore*
- YOSHIFUMI NISHIKAWA • *National Research Center for Protozoan Diseases, Obihiro University of Agriculture and Veterinary Medicine, Obihiro, Hokkaido, Japan*
- LISELOTTE ROTHMANN NORUP • *Department of Immunology and Microbiology, University of Copenhagen, Copenhagen, Denmark*
- JIANYI PAN • *Institute of Proteomics and Molecular Enzymology, School of Life Sciences, Zhejiang Sci-Tech University, Hangzhou, China*
- ATANAS PATRONOV • *Center for Integrated Protein Science Munich (CIPSM), Technical University of Munich, Freising-Weihenstephan, Germany; Department of Life Sciences, Technical University of Munich, Freising-Weihenstephan, Germany*
- REBECCA RACZ • *College of Pharmacy, University of Michigan, Ann Arbor, MI, USA; Unit for Laboratory Animal Medicine, University of Michigan Medical School, Ann Arbor, MI, USA*
- ROBERTO M. LA RAGIONE • *Department of Pathology and Infectious Diseases, School of Veterinary Medicine, University of Surrey, Guildford, Surrey, UK*
- NAUSHEEN RAHMAN • *Bioprocess Research and Development, Sanofi Pasteur, Toronto, ON, Canada*
- ANDREAS REIMANN • *Fraunhofer Institute for Molecular Biology and Applied Ecology IME, Aachen, Germany*
- SANDRA RING • *Institute of Immunobiology, St. Gallen, Switzerland*
- TIMOTHY C. RODELL • *GlobeImmune, Inc., Louisville, CO, USA*
- ALINA RODRÍGUEZ-MALLON • *Animal Biotechnology Department, Center for Genetic Engineering and Biotechnology, Havana, Cuba*
- XAVIER SAELENS • *Department of Biomedical Molecular Biology, Ghent University, Ghent, Belgium; Medical Biotechnology Center, VIB, Ghent, Belgium*
- PAULA DE S. SANTOS • *Laboratory of Nanobiotechnology, Institute of Genetics and Biochemistry, Federal University of Uberlandia, Uberlândia, MG, Brazil*
- GAURI SAXENA • *Department of Botany, University of Lucknow, Lucknow, India*
- STEFAN SCHILLBERG • *Fraunhofer Institute for Molecular Biology and Applied Ecology IME, Aachen, Germany*
- SEIJI SHIBASAKI • *General Education Center and Graduate School of Pharmacy, Hyogo University of Health Sciences, Kobe, Japan*
- SIMONE SIMIONATTO • *Faculdade de Ciências Biológicas e Ambientais, Universidade Federal da Grande Dourados, Rodovia Dourados – Cidade Universitaria, Cx., Dourados, MS, Brazil*
- SAMER SINGH • *Department of Microbial Biotechnology, Panjab University, Chandigarh, India*
- ANKIT SINGH • *National Research Centre on Plant Biotechnology, New Delhi, India*
- PETER M. SMOOKER • *School of Applied Sciences, RMIT University, Bundoora, VIC, Australia*
- EDNA SOARES • *Center for Neuroscience and Cell Biology, University of Coimbra, Coimbra, Portugal; Faculty of Pharmacy, University of Coimbra, Coimbra, Portugal*
- PRASERT SOBHON • *Department of Anatomy, Faculty of Science, Mahidol University, Bangkok, Thailand*
- STEPHEN SPATZ • *United States Department of Agriculture, US National Poultry Research Center, Agricultural Research Service, Athens, GA, USA*

- HOLGER SPIEGEL • *Fraunhofer Institute for Molecular Biology and Applied Ecology IME, Aachen, Germany*
- JING SUN • *Department of Veterinary Biosciences, College of Veterinary Medicine, The Ohio State University, Columbus, OH, USA*
- TETSUYA TANAKA • *Laboratory of Infectious Diseases, Joint Faculty of Veterinary Medicine, Kagoshima University, Kagoshima, Japan*
- PREM THAPA • *Microscopy and Analytical Imaging Lab, University of Kansas, Lawrence, KS, USA*
- RICHARD M. TWYMAN • *TRM Ltd, York, UK*
- MITSUYOSHI UEDA • *Division of Applied Life Sciences, Graduate School of Agriculture, Kyoto University, Kyoto, Japan*
- RIKA UMEMIYA-SHIRAFUJI • *National Research Center for Protozoan Diseases, Obihiro University of Agriculture and Veterinary Medicine, Obihiro, Hokkaido, Japan*
- PRAVEEN C. VERMA • *Centre for Plant Molecular Biology and Genetic Engineering, CSIR-National Botanical Research Institute, Rana Pratap Marg, Lucknow, India*
- MARGARITA VILLAR • *SaBio, Instituto de Investigación en Recursos Cinegéticos IREC-CSIC-UCLM-JCCM, Ronda de Toledo s/n, Ciudad Real, Spain*
- DAVID B. VOLKIN • *Department of Pharmaceutical Chemistry, Macromolecule and Vaccine Stabilization Center, University of Kansas, Lawrence, KS, USA*
- THOMAS WAHLI • *Centre for Fish and Wildlife Health, Vetsuisse, University of Bern, Bern, Switzerland*
- NEWTON WAHOME • *Department of Pharmaceutical Chemistry, Macromolecule and Vaccine Stabilization Center, University of Kansas, Lawrence, KS, USA*
- LILI WANG • *Department of Stomatology, Sichuan Provincial People's Hospital, Sichuan Academy of Medical Sciences, Chengdu, Sichuan, China*
- NING WANG • *School of Medical Engineering, Hefei University of Technology, Hefei, Anhui Province, China*
- TING WANG • *School of Pharmacy, Anhui Medical University, Hefei, Anhui Province, China*
- YONGWEI WEI • *Department of Veterinary Biosciences, College of Veterinary Medicine, The Ohio State University, Columbus, OH, USA*
- DUANGDAO WICHADAKUL • *Department of Computer Engineering, Faculty of Engineering, Chulalongkorn University, Bangkok, Thailand*
- MEI X. WU • *Wellman Center for Photomedicine, Massachusetts General Hospital, Department of Dermatology, Harvard Medical School, Boston, MA, USA*
- ZHIQUAN XIANG • *The Wistar Institute, Philadelphia, PA, USA*
- JUNFENG XIE • *State Key Laboratory of Biocontrol, School of Life Sciences, Sun Yat-sen University, Guangzhou, China; MOE Key Laboratory of Aquatic Product Safety, School of Marine Sciences, Sun Yat-sen University, Guangzhou, China; Institute of Aquatic Economic Animals, School of Life Sciences, Sun Yat-sen University, Guangzhou, China; Guangdong Province Key Laboratory for Aquatic Economic Animals, School of Life Sciences, Sun Yat-sen University, Guangzhou, China*
- YICHANG XU • *School of Computer Science, Fudan University, Shanghai, China; Shanghai Key Lab of Intelligent Information Processing, Fudan University, Shanghai, China*
- HIDEKI YAMAJI • *Department of Chemical Science and Engineering, Graduate School of Engineering, Kobe University, Nada, Kobe, Japan*
- HAO YAN • *Center for Molecular Design and Biomimetics, The Biodesign Institute, Arizona State University, Tempe, AZ, USA; Department of Chemistry and Biochemistry, Arizona State University, Tempe, AZ, USA*

- HUAN YONG YAP • *School of Applied Sciences, RMIT University, Bundoora, VIC, Australia*
- ZHICANG YE • *Institute of Proteomics and Molecular Enzymology, School of Life Sciences, Zhejiang Sci-Tech University, Hangzhou, China*
- QINGZHONG YU • *United States Department of Agriculture, US National Poultry Research Center, Agricultural Research Service, Athens, GA, USA*
- YU ZHANG • *Department of Veterinary Biosciences, College of Veterinary Medicine, The Ohio State University, Columbus, OH, USA*
- WEI ZHAO • *United States Department of Agriculture, US National Poultry Research Center, Agricultural Research Service, Athens, GA, USA; Beijing Centre for Disease Control and Prevention, Beijing, China*
- XIANGYANG ZHOU • *The Wistar Institute, Philadelphia, PA, USA*
- SHANFENG ZHU • *School of Computer Science, Fudan University, Shanghai, China; Shanghai Key Lab of Intelligent Information Processing, Fudan University, Shanghai, China*
- LASZLO ZSAK • *United States Department of Agriculture, US National Poultry Research Center, Agricultural Research Service, Athens, GA, USA*
- ALBERTHA R. VAN ZYL • *Biopharming Research Unit, Department of Molecular and Cell Biology, University of Cape Town, Rondebosch, South Africa*

Part I

Challenges in Veterinary Vaccine Development

Chapter 1

Challenges in Veterinary Vaccine Development and Immunization

Mark A. Chambers, Simon P. Graham, and Roberto M. La Ragione

Abbreviations

AI(V)	Avian influenza (virus)
BVD	Bovine viral diarrhea, caused by the Pestivirus, BVDV
FMD	Foot-and-mouth disease, caused by the Picornavirus, FMDV
IB	Avian infectious bronchitis caused by the Coronavirus, IBV
IBD	Infectious bursal disease caused by the Birnavirus, IBDV
ILT	Infectious laryngotracheitis, caused by the Herpesvirus, Gallid herpesvirus 1 (GaHV-1/ILTV)
MDV	Marek's disease, caused by the Herpesvirus, Gallid herpesvirus 2 (GaHV-2/MDV)
ND	Newcastle disease, caused by the Paramyxovirus, NDV
PRRS	Porcine reproductive and respiratory syndrome, caused by the Arterivirus, PRRSV
PRV	Pseudorabies virus (Suid herpesvirus 1), the causative agent of Aujeszky's disease

1 Introduction

Infectious diseases of livestock have a direct major financial impact globally through production losses arising from morbidity and mortality. Such losses can include poor weight gain or productivity, condemnation of product, lower commercial return, and inability to trade nationally and internationally. A number of infectious diseases of mammals and birds are of additional global concern due to their zoonotic potential, their ability to be carried across geographical boundaries, their ability to jump species, and to evade or subvert host immune defenses and to throw-off more virulent variants. Examples include influenza viruses, *Salmonella*, and *Leishmania*. The direct and indirect social and economic costs associated with infection are hard to assess [1], but can be dramatic. For example, the H1N1 influenza pandemic in Mexico in 2009 directly affected tourism, the service sector, retail trade, transport, entertainment,

the agricultural industry (particularly pig farmers) and depressed international investment. The outbreak is estimated to have reduced economic activity by 0.3–0.5 % of gross domestic product (i.e., between US\$ 2.7 and 4.5 billion) [2]. The 2001 foot and mouth disease (FMD) outbreak in the UK took 7 months to eradicate, resulted in the slaughter of more than six million animals and was estimated to cost £8 billion to the public and private sectors [3], as well as having considerable environmental costs [4].

Vaccines can be used to prevent, manage, or eradicate disease and are set to become increasingly important as front-line control tools, especially as bacteria progressively emerge with wide resistance to available antibiotics and the burden of parasites resistant to antiparasitics increases. The demand for alternative means of controlling disease and enhancing livestock health is driven by increasing concern of consumers over the potential for drug and antibiotic residues in meat [5] and greater awareness of the burden of antibiotic resistance in the environment [6]. However, vaccines are not a “silver bullet.” To be most effective they invariably need to be deployed within comprehensive control strategies that include detailed understanding of the disease epidemiology, biosecurity, quarantine, surveillance, diagnosis, education, and control of the disease vector or reservoir species. It was this combination of measures that resulted in the eradication of Rinderpest through vaccination [7]. Indeed, veterinary vaccines can be remarkably effective. As well as enabling Rinderpest to be eradicated, the development of safe, affordable rabies vaccines efficacious in a variety of species has resulted in dramatic reductions in the burden of this devastating disease in some continents [8] and vaccination against the parasitic protozoa *Eimeria* has been a major success in the fight against avian coccidiosis, arguably one of the most economically important livestock diseases in the world [9]. The recent deployment of the first genetically modified live bacterial vaccine for avian pathogenic *E. coli* has opened the market for a new range of vaccines [10].

The focus of this review is on vaccination against infectious disease. Other applications of vaccination include those designed to provide protection against noninfectious diseases such as allergies and cancers, and those designed to control fertility and production. For consideration of vaccination for these applications in veterinary species the reader is directed to the excellent review of Meeusen et al. [11]. The reader may also wish to read the recent review by Knight-Jones et al. that describes aspects of the evaluation of veterinary vaccines and how this compares and contrasts with human vaccine evaluation [12].

In the following figure (Fig. 1) we present a framework that describes the different elements that may be considered when developing veterinary vaccines. This review focuses more on the scientific elements at the center of the figure, but the cost of development, practicality of use, challenges to licensing, and the even-

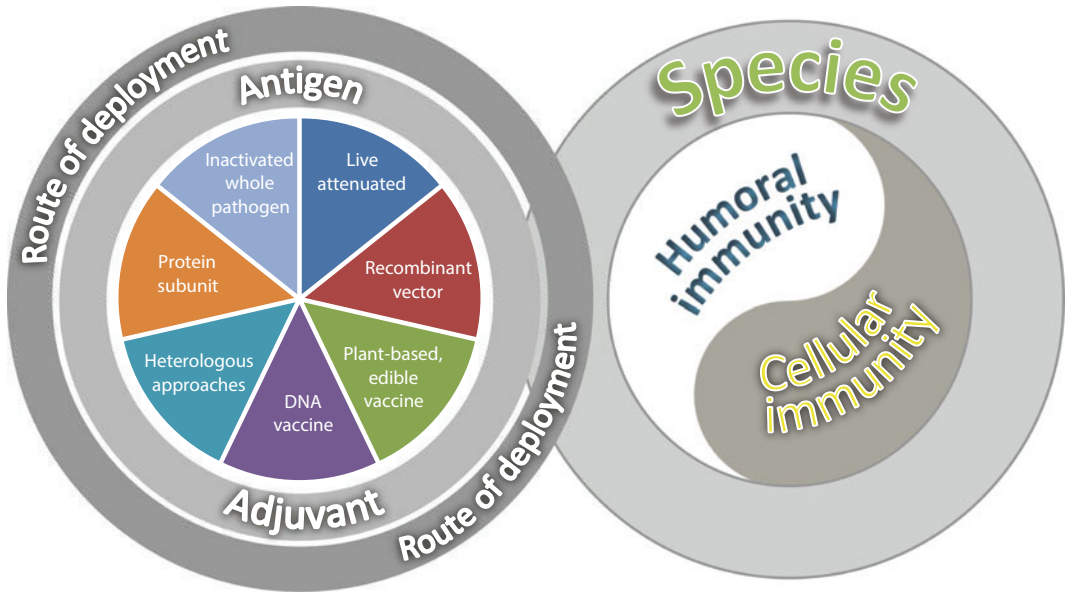

Fig. 1 Different elements that have to be considered when developing veterinary vaccines

tual market value of the vaccine are all crucial considerations that may ultimately dictate whether a veterinary vaccine proceeds to market. Readers are directed to the excellent online resource, Vetvac (<http://www.vetvac.org/index.php>), a free searchable global database of commercially available livestock vaccines. One can search by vaccine name, pathogen, manufacturer, host species, and country of interest, and combine search terms. For access to research data for commercial vaccines and vaccines in clinical trials or in early stages of research, readers are directed to the Vaccine Investigation and Online Information Network (VIOLIN) database (<http://www.violinet.org>). For researchers in the UK, the Veterinary Vaccinology Network (www.vetvacnet.org) is a multi-disciplinary network with the aims of facilitating knowledge exchange and discussion, fostering development and uptake of novel tools and technologies, and addressing unmet needs in protective immunity in the field of veterinary vaccinology [13].

2 Choice of Target Species

The target host species for vaccine development is often dictated by the economic impact of the disease or the risk the species represents for onward transmission of a pathogen, although it may also be a candidate for vaccination if it is valuable to protect in its own right, e.g., companion animals, rare species or zoological collections. Typically the species of concern is targeted directly for

vaccination. However, it may be that the vaccine is targeted to a reservoir species that presents a risk. For example, European badgers (*Meles meles*) may be vaccinated against bovine tuberculosis (TB) in England and Wales with BCG (Bacillus Calmette–Guérin) (BadgerBCG, Animal and Plant Health Agency, UK) in an effort to break the transmission of *Mycobacterium bovis* infection between badgers and cattle. There are also experimental vaccines against *Toxoplasma gondii* infection of domestic cats that could be used to reduce excretion of oocytes into the environment, thereby protecting sheep from infection with the parasite resulting in abortion [14]. Another important application of vaccination of veterinary species is to protect humans from zoonoses. Examples of this include vaccination of domestic dogs and sylvatic carnivore species to protect against rabies in humans and domestic and companion animals; vaccination of poultry and pigs against zoonotic serovars of *Salmonella* spp.; vaccination of cattle against enterohemorrhagic *Escherichia coli* O157:H7 [15]; and the proposed vaccination of dogs against *Leishmania* spp. to protect humans against visceral leishmaniasis [16].

Where there are multiple host species for the same pathogen, there may be a lack of information on the efficacy of a vaccine in all affected species. The efficacy of a vaccine may vary between species, making extrapolation from one to another difficult. For example, because of their commercial value, chickens and turkeys are the focus of avian influenza (AI) vaccination and the only bird species for which there are licensed vaccines. Whilst ducks and geese may be significant reservoirs of AI viruses, including highly pathogenic variants, the performance of vaccines in these species is largely unknown.

3 Choice of Vaccine Approach

3.1 Inactivated Whole-Pathogen

There are many examples of the use of inactivated whole-pathogens as successful veterinary vaccines spanning several decades. These include inactivated viruses, e.g., for swine and avian influenza and bovine viral diarrhea (BVD), parasites, e.g., for leishmaniasis and spontaneous abortion in cattle caused by *Neospora caninum*, and bacteria, e.g., immunization of dogs against *Borrelia* spp. Inactivation is usually brought about by heat or chemical treatment or irradiation.

The advantage of vaccines based on the whole-pathogen is that they are generally stable and retain a high proportion of the antigens of the live pathogen. However, by definition they are unable to infect or replicate in the host or express antigens associated with active metabolism, replication, or other life-cycle stages. As a consequence, inactivated whole-pathogen vaccines often require booster immunizations and the inclusion of adjuvants to achieve adequate protection.

One novel approach involves the creation of bacterial “ghosts.” Bacterial ghosts are nonliving gram-negative bacterial cell envelopes devoid of cytoplasmic contents while maintaining their cellular morphology and native surface antigenic structures. They are produced by bacteriophage protein-mediated lysis of the bacteria. As well as containing intrinsic adjuvant properties, bacterial ghost preparations can be made containing additional antigens that are expressed in the envelope complex of the bacteria before they are lysed. The advantages of bacterial ghosts include the simplicity of the production method, safety, independence from the cold chain, and versatility to express multiple antigens as a combination vaccine. We are not aware of any commercial vaccines based on bacterial ghost preparations. Recent experimental evaluation of ghosts prepared from *Salmonella enterica* serovar Enteritidis carrying the *E. coli* heat-labile enterotoxin B subunit as an adjuvant gave very encouraging protection to chickens against challenge with a virulent *Salmonella* Enteritidis strain [17].

Inactivated whole-virus vaccines may not induce cross-protection from one viral geno/sero-type to another, e.g., for FMDV, possibly due to inactivated whole-pathogen vaccines working via the induction of antibody-mediated immunity and not via the induction of cell-mediated immune responses which may be more broadly cross-reactive, although this limitation may be overcome by including multiple inactivated types in the same vaccine preparation.

3.2 Live Attenuated Pathogens

Live attenuated vaccines are reduced virulence versions of the target pathogen that retain the ability to undergo limited replication within the host, thereby inducing cellular and/or humoral immune responses that are relevant to conferring protection against the fully virulent organism. As a consequence, live attenuated vaccines rarely require an adjuvant to be effective and can be administered in a way that mimics the natural route of infection. They can be highly effective vaccines capable of providing lifelong immunity. For example, the eradication of Rinderpest virus, only the second pathogen after smallpox virus to have been eliminated via human intervention, was the result of the targeted use of an efficacious live attenuated vaccine [7]. Vaccination against *Trichophyton verrucosum* with an attenuated strain of *T. verrucosum* (Bovilis Ringvac LTF-130, Merck Animal Health) has all but eradicated bovine ringworm from the national herd in Norway [18].

A significant advantage of live vaccines is that they express a wider range of relevant pathogen antigens, including those that require active metabolism. This is particularly important for vaccines against protozoan or helminth parasites since antigens may be differentially expressed between life cycle stages. The commercial protozoal vaccine Toxovax (MSD Animal Health) protects ewes against infection with *Toxoplasma gondii*. The attenuated vaccine strain of *T. gondii* (S48) cannot form cysts and is therefore unable

to persist. The commercial helminthic vaccine Bovilis® Huskvac (MSD Animal Health) protects cattle against the lungworm *Dictyocaulus viviparus*. The vaccine contains 1000–2000 viable *D. viviparus* infective third stage larvae that are irradiated to prevent their development into the mature adult stage.

Pathogen attenuation is often induced by serial passage through in vitro culture or infection of alternative hosts with reliance on random mutations to result in reduced virulence in the target host. The paradigm for such a vaccine was the development of BCG vaccine against TB. Starting with a virulent bovine strain of *M. bovis*, Albert Calmette and Camille Guérin cultured the bacteria on a medium composed of ox bile, glycerine and potato and then subcultured the bacteria at roughly 3 weekly intervals. After 11 years or approximately 230 subcultures the bacteria failed to produce progressive TB when injected into a variety of mammalian species, including cattle. Since that time, BCG remains the only TB vaccine licensed for use in humans and has been the subject of numerous trials in cattle to test its ability to protect against bovine TB. As has been observed for humans, BCG's ability to confer protection to bovine TB is highly variable. However, its main limitation is that it can sensitize cattle to produce a positive tuberculin skin-test reaction, the mainstay of surveillance and control for bovine TB. Defining the genetic lesions in BCG responsible for attenuation became possible with the advent of whole-genome sequencing. The availability of the complete genome sequence data for many pathogens now permits selective deletion or disruption of genes to result in targeted attenuation. A good example of this is the recently launched avian pathogenic *E. coli* vaccine, Poulvac® *E. coli* (Zoetis) [10].

Despite their success for some diseases, there are a number of problems with many inactivated whole-pathogen or live attenuated vaccines including that the immune responses they induce are often indistinguishable from those elicited by natural infection. Thus, they do not readily allow for differentiation between infected versus vaccinated animals (DIVA), which makes them less suitable for use in disease eradication efforts. Some notable examples include foot-and-mouth disease (FMD), leptospirosis, brucellosis and bovine TB. Vaccines may interfere with surveillance methods in two different ways: either it is not possible to differentiate the wild-type pathogen from its vaccine strain in a diagnostic sample, e.g., for infectious bursal disease (IBD), Newcastle disease (ND), and FMD; or a vaccine generates false positivity in an immunodiagnostic test. For example, seroconversion following vaccination against IBD or sensitization of vaccinated livestock to the single bovine intradermal tuberculin test as a consequence of vaccination with the paratuberculosis/Johne's disease vaccine, Silirum® (CZ Veterinaria) [19] or BCG. In the latter case, considerable effort has been invested in the characterization and validation of DIVA diagnostic reagents that

might permit the use of BCG in cattle. In some cases, the gene product disrupted for attenuation may encode an immunodominant, unprotective, nonessential antigen and this can be used as the basis of a DIVA test to discriminate vaccination from infection with wild-type pathogen.

Attenuated virus vaccines are generally considered more efficacious than inactivated whole-virus vaccines since they induce stronger T cell responses, high titers of virus-neutralizing antibodies and provide a longer duration of protection from clinical disease. However, there is a risk that the vaccine virus can revert to a virulent form or recombine with field viruses and cause disease. This was seen with attenuated vaccines for both BVD and porcine reproductive and respiratory syndrome (PRRS). In the case of attenuated vaccines against AI, there is an inherent risk of gene reassortment with wild-type viruses and the emergence of pathogenic variants. Infectious laryngotracheitis (ILT) is a particular problem for the intensive poultry industry. Attenuated vaccines for ILT, particularly those derived by passage in chicken embryos, have been associated with a number of side effects, including residual virulence, transmission to naïve birds, latent infection with subsequent reactivation and shedding of virus, and reversion to virulence after passage in vivo. Most recently, recombination between attenuated ILT vaccines in the field has been shown to be responsible for the emergence of new virulent viruses that have caused widespread disease.

In pregnant animals, live vaccines present a risk of vertical transmission of the attenuated pathogen that can result in fetal complications or persistent infection [20]. As a result, some live attenuated viral vaccines are not licensed in a number of countries. Attenuated bacterial vaccines may also retain a degree of virulence that provides impetus to developing safer vaccines of equal efficacy. For example, the most widely used live attenuated vaccines for *Brucella abortus* and *B. melitensis* can induce abortion in the host and brucellosis in people.

3.3 Protein Subunit

The major advantage of subunit vaccines is their safety. However, their production as recombinant protein relies on knowledge of the protective antigen. In many cases this is either unknown or protection is mediated through a variety of antigens. The latter may not necessarily be an issue, as exemplified by commercial vaccines available for porcine contagious pleuropneumonia where four or five recombinant proteins from the causative organism *Actinobacillus pleuropneumoniae* are combined to provide protection against all known *A. pleuropneumoniae* serotypes. A further limitation is that the recombinant form of the antigen may not induce the same type or extent of immune response as the native antigen because it doesn't preserve native conformation. This is a particular issue for vaccines against parasites and viruses where the target for vaccination is often a glycoprotein.

As for inactivated whole-pathogen vaccines, subunit protein vaccines are often poorly immunogenic and require booster immunizations and inclusion of adjuvants to achieve adequate protection. When added to their relatively high cost of production, this makes them less attractive commercially. Nonetheless, there are some commercial subunit vaccines based on recombinant protein, e.g., the Porcilis PCV vaccine (MSD Animal Health) is based on the baculovirus-vectored expression of recombinant ORF2 protein of porcine circovirus type 2 (PCV2), the causative virus of porcine circoviral disease including the post-weaning multi-systemic wasting syndrome of pigs.

More rarely, the subunits may be native proteins often isolated from the supernatants of pathogen cultures. An example of this is the soluble parasite antigens released by culture of *Babesia canis*. When combined with adjuvant, these antigens form effective vaccines against canine babesiosis.

3.4 Recombinant Vector

Exogenous vaccine genes can be presented and expressed in the context of a vector organism. Frequently the vector is a virus, such as a herpesvirus, adenovirus, or poxvirus, but bacterial vectors are also used, including BCG and *Salmonella*, as well as bacterial endospores [21]. Some recombinant vector vaccines are licensed for use, such as a vaccine for H5 clade AI based on a recombinant fowlpox virus vector (Trovac-AIV H5, Merial), a vaccine for equine influenza based on canarypox virus (Proteq-Flu/Recombitek, Merial) and rabies vaccine based on recombinant vaccinia virus. Recombinant poxviruses are particularly attractive vaccine vehicles as they are environmentally robust, genetically stable, safe, produce long-lasting immunity and can accommodate a large amount of foreign DNA. The vaccinia virus vectored rabies vaccine has been particularly successful as an oral vaccine vector against rabies in wild carnivores, resulting in substantial control of the disease throughout Western Europe and the USA. Virally vectored recombinant vaccines have been developed against ILT in an effort to address the numerous side-effects seen with attenuated viral vaccines (reviewed in Ref. [22]). Some of these have been licensed recently for use in some areas of North and South America, such as Vectormune® (FP-LT, Ceva Animal Health), based on a recombinant fowlpox vector.

An attractive approach is to make an attenuated form of a target pathogen as the vector organism with the aim of generating a bivalent vaccine eliciting protective immunity to both the vector and the heterologous antigen(s) it expresses. No such vaccines have yet been licensed using a bacterial or parasite vector but have been for viral vectors. Simultaneous protection against Marek's disease virus (MDV) and either IBDV (Vaxxitek HVT+IBD, Merial) or ILTV (Innovax®-ILT, Intervet International B.V; Vectormune® HVT-LT, Ceva Biomune) has been possible using turkey herpesvirus as the vector to express IBDV or ILTV anti-

gens. Turkey herpesvirus is nonpathogenic for chickens but confers cross-protection to MDV. Encouraging results have also been seen with live *Salmonella* vectors expressing peptide epitopes from *Campylobacter* proteins [23]. Recent progress in the genetic manipulation of *Eimeria* species presents the exciting opportunity for the creation of transgenic parasite lines as host-specific vaccine delivery vectors expressing one or more foreign proteins to provide simultaneous protection against coccidiosis and other veterinary or zoonotic pathogens [24]. However, it is also worth noting that preexisting anti-vector immunity can neutralize these vaccines and significantly diminish their immunogenicity.

3.5 DNA Vaccine

DNA vaccines are based on the ability of injected plasmids to express vaccine antigens, under the control of an appropriate eukaryotic promoter, in host tissue, in particular muscle cells and skin epithelia. Recombinant plasmid DNA is both relatively cheap to produce and sufficiently stable to avoid the necessity for a cold-chain in many cases. However, the level of protective immunity induced by DNA vaccination is often low unless relatively large quantities of DNA are injected, so as for recombinant protein vaccines, their cost is often prohibitive. One application where they have been found to be particularly successful is in protecting fish against viral diseases, such as infectious hematopoietic necrosis in Atlantic salmon (Apex-IHN, Novartis). At present, fish must be injected with the DNA vaccine intramuscularly, a process that is surprisingly efficient (see videos at <http://www.norvacc.com/video-7.html>).

3.6 Plant-Based/ Edible Vaccines

The expression of recombinant vaccine antigen(s) in plants that could be fed to target species in order to generate and maintain protective immunity is an attractive option that has been explored for two decades; recently in the EU FP7 project PLAPROVA (project reference: 227056). This 3 year project completed in 2012 (http://cordis.europa.eu/project/rcn/89887_en.html) and focussed on AIV, blue tongue virus and PRRSV. There have also been encouraging results using recombinant antibodies against *E. coli* O157:H7 produced in plants [25, 26]. A challenge is overcoming the propensity for oral vaccines to induce immune tolerance. The first plant-based vaccine (for ND) was licensed in 2005. As well as protecting against viruses of domestic species, the approach also shows promise for the delivery of parasite antigens to the gut associated lymphoid tissues (e.g., for fasciolosis, schistosomiasis, poultry coccidiosis, porcine cysticercosis and ascariasis) or passive immunization through the delivery of plant-expressed antibodies. The reader with an interest in progress in plant-based, edible vaccines is directed to recent reviews of the subject [27–29]. Despite the promise of plant-based vaccines there are concerns with public acceptance of GM foodstuffs for livestock and the risk they pose to contamination of the human food chain or the environment [30].

3.7 Heterologous Approaches

Some approaches to vaccination exploit a synergy where two different vaccines to the same pathogen are combined to augment protective immunity. We break these down into two broad approaches. The first has been termed, heterologous prime-boost. The second approach exploits what we refer to as combination vaccines.

3.7.1 Heterologous Prime-Boost

In this scenario, the host is first primed with one type of vaccine, such as a live viral vector expressing antigen(s), followed by boosting with another vaccine, such as a live attenuated vaccine that expresses the same antigen(s) present in the priming vaccine. The objective is to boost or enhance immunity to the antigen(s) in a way that is more effective than using the same vaccine for priming and boosting. Comprehensive proof of principle for this approach has been demonstrated for vaccination against *M. bovis*, the cause of bovine TB. A number of vaccination strategies have been evaluated for their protective effect in a bovine challenge model (reviewed in Ref. [31]). Currently the most effective vaccination strategy against bovine TB is based on priming the immune system with the live attenuated BCG vaccine followed by boosting with a subunit vaccine containing protective antigens that are present in BCG. A number of these heterologous prime-boost regimes have conferred greater relative protection to cattle than immunization with BCG alone. The most promising combinations combine a prime with BCG followed by boosting with either modified vaccinia virus Ankara strain (MVA) or attenuated adenoviruses expressing the mycobacterial antigen Ag85A [32].

Another example is the comprehensive evaluation of heterologous prime-boost vaccination regimes against pseudorabies virus (PRV) infection causing Aujeszky's disease in pigs [33]. In this study the efficacy of a conventional modified live vaccine was compared with the efficacy of different prime-boost regimes. These consisted of homologous prime-boost regimes (DNA–DNA vaccination or parapox virus–virus vaccination) or heterologous prime-boost regimes (DNA–virus or virus–DNA), all expressing glycoprotein D of PRV. The different prime-boost regimes resulted in variable levels of immunogenicity and protection against challenge infection. Most effective was the regime of priming with DNA followed by boosting with the parapoxvirus vector. This regime resulted in strong antibody responses comparable to the responses obtained after prime-boost vaccination with the modified live vaccine and a level of protection to challenge better than the other prime-boost regimes. From a practical perspective, heterologous prime-boost approaches can suffer from the disadvantage that two vaccines must be produced/administered in the place of one. Furthermore, there is added practical complexity that the two vaccines must be administered often in the correct sequence to achieve the required protection.

3.7.2 Combination Vaccines

In this scenario two different vaccines to the same pathogen are administered simultaneously, with the objective of enhancing protective immunity. There are numerous successful examples of this approach. Typically the combination is against different strains of the same pathogen using the same vaccine form. An example of this is Poulvac IB Primer (Zoetis), a lyophilized vaccine containing two attenuated strains of avian infectious bronchitis virus (IBV): Massachusetts serotype HI20 and Dutch variant strains D207/D274. Alternatively, the combination may be based on different vaccine types. For example, the simultaneous administration of live and inactivated vaccines against NDV provides better protection and has been used successfully in control programs in areas of intense poultry production. In some cases the licensed vaccine contains multiple vaccines against different pathogens, e.g., the RECOMBITEK® C4 (Merial) vaccine comprises a modified live virus and a canarypox vector to confer protection against canine distemper, Adenovirus Type 2, Parainfluenza, and Parvovirus, and the RECOMBITEK® C6 (Merial) vaccine adds a liquid suspension of inactivated cultures of *Leptospira canicola* and *L. icterohaemorrhagiae* to confer additional protection against Leptospirosis.

4 Choice of Antigen

Many of the points relating to the choice of vaccine antigen have been alluded to already. An essential consideration is whether sufficient protective immunity can be produced using a single antigen or whether multiple antigens are required. Indeed, it may not even be known what the protective antigens are or the mechanisms of protective immunity, which may guide an antigen identification or evaluation strategy. Even if the protective antigen is known there are still important considerations and constraints that often dictate the type of vaccine that is developed; for example, the extent to which the antigen varies naturally and whether it is necessary to retain native antigen conformation to establish protective immunity with the vaccine. Single-stranded RNA viruses, such as influenza, lentiviruses including feline immunodeficiency virus (FIV) and nidoviruses such as IBV and PRRSV evolve rapidly by antigenic drift and shift meaning a vaccine developed to one variant may provide limited cross-protection to heterologous variants, presenting a major obstacle for vaccine development. In some cases, vaccination with two genetically divergent vaccines to broaden the protection against heterologous types can be effective, as in the case of the Poulvac IB Primer (Zoetis) vaccine to avian IBV, described above.

A novel experimental vaccine for leishmaniasis extends consideration of the vaccine antigen to targets beyond the pathogen itself. In this study, vaccination was to the bite of the sand fly

vector. Immunity generated in a hamster model to a fly salivary protein resulted in protection against *Leishmania infantum*, suggesting a new approach to vaccination against infections transmitted by ectoparasites [34].

5 Choice of Immune Response To Be Targeted

This is frequently an aspect of vaccination that is poorly defined for the pathogen and/or the target species. This is exacerbated if the pathogen is difficult to work with experimentally or relatively little is known about the immune response of the target species and suitable reagents for its study are lacking. Good examples for this are the development of equine vaccines (reviewed in Ref. [35]) and vaccines against avian influenza (AI) in Anseriformes, such as ducks and geese [36, 37]. Only since 2004 has the full complement of horse immunoglobulin heavy chain constant region genes been described. The horse is atypical in that it expresses seven IgG subclasses. To achieve maximal protection to infections mediated by Fc receptor or complement-mediated elimination mechanisms, it appears vaccines should elicit IgG antibodies of particular IgG subclasses; other subclasses offering less effective protection [38]. Importantly, as the authors of this work point out, since IgG plays key roles in both serum and mucosal compartments in the horse, these considerations are applicable to both systemic and mucosal vaccination strategies. Vaccination of Anseriformes with existing AI vaccines requires a higher dose of antigen compared with chickens or the addition of a strong stimulator for the immune response to be effective. Differing immunoglobulin genetics is considered to be a significant contributing factor to this [36].

This said it is debatable whether it is necessary to have a clear understanding of the protective immune mechanisms before vaccine development can proceed. However, a good understanding of immunological correlates/surrogates of protection can reduce the need for expensive challenge experiments as part of the vaccine development process. Commercial vaccines, such as BCG for TB and Fel-O-Vax FIV for FIV are widely used vaccines yet the precise basis for their protection is unclear. This means we do not know why they fail to protect certain individuals. Poor understanding of the basis for protective immunity makes it hard to develop improved vaccines on a rational basis.

Even when a significant amount is known about the nature of protective immunity, the challenge may be that effective protection requires stimulation of different elements of immunity at different stages and in different anatomical locations. For example, antibodies only protect at the initial site of influenza infection whereas cellular responses, especially cytotoxic T-lymphocytes (CTL) are needed once initial infection has occurred. These considerations

dictate how the antigen is presented, e.g., vaccine-derived antigenic peptides must be processed and presented by MHC class I cytosolic or cross-presentation pathways for CTL responses to be generated.

In addition, the immune response required to protect against one pathogen may be antagonistic to the response required to another type of pathogen. This is best exemplified by the difference in protective immunity required against helminthic pathogens, that is characterized by the type 2 immune response, compared to the response required for intracellular pathogens, that is characterized by type 1 immune responses. This of course is a generalization but it highlights how antagonism between the two broad arms of immunity can be a hurdle to vaccination; underlying concomitant infections may skew the immune response making redirection of the immune response by vaccination a challenge.

As innate immunity is considered to be evolutionary primitive compared to acquired immunity, many elements of the innate response are common amongst veterinary species, such as the universal existence of pattern recognition receptors (PRRs) able to respond to pathogen-associated molecular patterns (reviewed in Ref. [39]). Increasing our understanding of the innate immune response to pathogens should result in the development of molecular adjuvants to enhance and/or refine the host response to vaccination.

6 Adjuvants

An adjuvant enhances the magnitude or duration of immunity, can accelerate the onset of immunity, direct its nature, prolong immunological memory, reduce the dose of antigen required to establish immunity, or a combination of these actions. They do this by either sequestering the antigen or targeting it to an antigen-presenting cell (APC), by activating the APC, or modifying the behavior of T-cells. Some vaccines contain inherent adjuvanticity due to their ability to stimulate the innate immune system via engagement of PRRs. Inactivated whole-virus or subunit vaccines invariably need an adjuvant to boost delayed or weak protective immunity, e.g., for swine influenza virus or PRRSV, especially where the pathogen downregulates host immunity, e.g., PRRSV and to overcome the effects of maternal antibodies on young animals (a form of vaccine interference—*see* Subheading 9).

The choice of adjuvants is considerable. One advantage faced by those developing vaccines for veterinary species compared to human is that the use of adjuvants is currently less restricted. There have been numerous reviews of adjuvants for use in humans and animals over the last 20 years and we would refer readers to those listed below in particular. In the following table (Table 1) we present

Table 1**Summary of adjuvants available for veterinary vaccine development by type**

Examples (incl. brand name where appropriate)		
Type of adjuvant	Those underlined are in use in licensed vaccines	Notes
Oil emulsion	Freund's Complete and <u>Incomplete Adjuvants</u> , <u>Montanide</u> [®] , Titermax [®] , Ribi [®] , SAF [®] , MF59	May be W/O (water in oil) or O/W (oil in water), or further combinations, e.g., W/O/W
Microparticle	<u>Aluminum hydroxide</u> , <u>potassium aluminum sulfate (alum)</u> , <u>aluminum phosphate (alhydrogel)</u> , calcium phosphate, immune stimulating complexes of Quillaja saponins (ISCOMs), poly(lactide-co-glycolide) (PLG), alginate, liposomes, non-ionic block copolymers, virosomes, cochleates, poloxamers, virus-like particles (VLPs)	
(Immuno)-active compounds	Saponin (Quil A or <u>QS-21</u>), DDA, Monophosphoryl lipid A (MPL A), cytokines (IL-1, -2, -6, -8, -12, TNF- α , GM-CSF, MIP-2, type I interferons), chitosan	Cytokines have been evaluated particularly in ruminants, pigs, and birds
Microbial derived	Heat-labile enterotoxin and cholera toxin (LT, CT) and mutants thereof (LTK63, LTR72), (lipo)polysaccharides, CpG oligonucleotides, lipopeptides, flagellin and other Toll-like receptor agonists	
Synthetic polymers	Polyanhydrides, polyesters, polyester amides, dextran	

Information in this table was partly taken from data presented in the following reviews to which the interested reader is directed: [40–44]

a synthesis of information described in these reviews and gleaned from other published studies. It is almost certainly not exhaustive but serves to describe the wide range and nature of adjuvants available or under development. Some adjuvants could be described under more than one type but these, e.g., saponin and CpG oligonucleotides, are listed only once for simplicity. Many veterinary adjuvant-vaccine formulations are proprietary and their compositions have not been disclosed. The reviews provide more detail for the different adjuvants regarding their composition, structure, mode of action, type of immune response they stimulate (where known), target host species, and pathogen for which they have been evaluated.

The use of adjuvants in veterinary species has not been without notable side effects. For example, the occurrence of vaccine-associated malignant sarcomas in cats is attributed to the use of aluminum salt

adjuvanted vaccines [45]. The hemorrhagic disorder; bovine neonatal pancytopenia (“bleeding calf syndrome”) that emerged in 2007 in several European countries was reported to be linked to the use of the BVDV vaccine PregSure®BVD. Moreover, this association was attributed by some to the presence of significant amounts of bioprocess impurities within the vaccine combined with a powerful adjuvant system [46]. This apparent association led to the withdrawal of the product from the market in 2011.

7 Route of Vaccination/Efficacy of Delivery

Considerations over the most appropriate route of delivery for the vaccine may be driven by practicality, concerns over local reactivity, or attempts to enhance or direct the immune response in a desired way. Since the route of entry for many pathogens is at mucosal surfaces, the induction of immunity at mucosal surfaces is critical to prevent infection. Therefore numerous attempts have been made to deliver vaccines to mucosal surfaces (oral, ocular, nasal). It is often generalized that a common mucosal immune system exists whereby antigenic stimulation of immunity at one mucosal site results in the secretion of IgA at a distant mucosal site. However, in many cases this has shown not to be the case. Instead there is functional compartmentalization and limited reciprocity between sites. Basic understanding of the extent to which the target species shares a common mucosal immune system is an essential consideration in determining the most appropriate route of immunization. For instance, whilst oral immunization may confer protection in the respiratory tract, the converse may not be true.

The oral route is likely to be the favored route for targeting populations or larger groups of animals, especially wildlife species and poultry. However, in the case of vaccine delivery for wildlife it is dependent on presentation in bait and the most suitable bait and baiting strategy may differ between species and contexts, as exemplified by rabies vaccination [47]. Automated *in ovo* vaccination is an emerging technology for poultry, e.g., using the Inovoject® System (an Embrex® BioDevice from Zoetis) to deliver Inovocox® vaccine against coccidiosis. The manufacturers claim advantages for the system over oral or parenteral vaccination of chicks such as consistent and uniform vaccine delivery, reduced chick stress, earlier immune response and protection, and significant labor savings. DNA vaccination may be improved through attempts to improve transfection efficiency, such as transcutaneous injection, biolistic particle delivery, or electroporation (reviewed in Ref. [48]), but these methods are not yet in routine use with livestock. For fish, the route of vaccine delivery is an important factor in influencing efficacy. The most efficient delivery route at present is intramuscular (IM) injection [49], but suitable delivery strategies

for mass vaccination of small juvenile fish have yet to be developed. Other methods evaluated for vaccination of fish include scarification of the skin, intraperitoneal injection, intrabuccal administration, cutaneous particle bombardment using a gene gun, or immersion [50, 51]. The ideal approach would be oral or immersion delivery of vaccine, but so far gene gun mediated delivery appears the most promising alternative to IM injection although it remains at the research stage.

8 Illustrative Examples

The challenges and the diversity of approaches taken to veterinary vaccine development are well illustrated by a few examples for which the authors have particular experience.

8.1 Porcine Reproductive and Respiratory Syndrome (PRRS)

PRRS is arguably the most important disease impacting the swine industry worldwide. Improving the efficacy of vaccination against PRRS is a major challenge particularly since the PRRS virus (PRRSV) is rapidly evolving and diversifying. Progress is hampered by uncertainty over the viral targets of protective immunity and significant knowledge gaps in the understanding of the mechanisms of host protective immunity to PRRSV infection. The lack of reliable correlates of immunity that mean novel vaccines need to be tested empirically and the genetic diversity of PRRSV means extrapolation of results between isolates is risky.

According to www.vetvac.org, there are currently 25 commercially available PRRSV vaccines; 15 live attenuated and ten inactivated vaccines, which are derived from both the North American and European PRRSV genotypes. Modified live vaccines (MLVs) were rapidly developed following the almost simultaneous emergence of the two PRRSV genotypes in North America and Western Europe some 25 years ago. The market leading MLV (Ingelvac PRRS MLV, Boehringer Ingelheim) was based on a North American genotype isolate and it has now been attributed as being responsible for the introduction of North American PRRSV to over eight countries outside of this continent [52]. This sharply illustrates the capacity of attenuated PRRSV to revert to virulence, a property facilitated by a high-mutation rate during PRRSV replication. In addition, there are numerous reports of PRRS disease outbreaks being caused by “vaccine-like” isolates [53–58]. Despite these safety issues, MLVs continue to be widely used, which is undoubtedly driven by the limited efficacy of inactivated vaccines particularly against heterologous strains. Inactivated PRRSV vaccines are therefore best suited as autogenous or “farm-specific” vaccines as proposed by Geldhof et al. [59, 60].

PRRSV-specific antibody responses can be observed from 7 to 10 days post-infection [61], however, these antibodies often do

not neutralize PRRSV infectivity [62]. Neutralizing antibodies (nAbs) may not be observed until at least 4 weeks post-infection, and titers, when measurable, are lower than those elicited by other viral infections [61, 63, 64]. Passive transfer experiments have shown that nAbs can provide a dose-dependent protection against PRRSV [65–67] and whilst data on protection against heterologous strains by passive transfer is limited, these studies suggest that vaccination strategies inducing high-titer nAbs may be efficacious. Consequently, the majority of approaches to develop the next generation of PRRSV vaccines have focussed on targeting the nAb response. During PRRSV infection antibodies are directed against a broad range of viral antigens and nAb responses have been mapped to GP2, GP3, GP4, GP5, and M proteins [68–76]. The early identification of highly conserved linear epitopes in the ectodomain of the major glycoprotein GP5 [73, 74, 77, 78] focussed vaccine development efforts on this antigen. However, recombinant GP5 protein was poorly immunogenic, failed to provide protection and could exacerbate disease upon challenge [79–82]. Expression of GP5 by plasmid DNA or viral vectors, alone or in conjunction with other PRRSV structural proteins, showed better immunogenicity, but typically failed to induce high titer nAbs and at best conferred only a degree of protection [83–92]. Other studies have shed doubt on whether GP5 represents the prime vaccine candidate, including: the observation that glycosylation sites on GP5, proposed to mask antibody epitopes, are highly variable amongst strains [93]; studies with chimeric viruses have shown that GP5 is nonessential for infection of macrophages [94]; pigs engineered to lack the GP5 receptor sialoadhesin show an unaltered course of PRRSV infection [95]; and affinity purified GP5-specific Ab fail to neutralize PRRSV infectivity *in vitro* [76, 96]. There is consequently an increased focus on the minor envelope proteins, GP2, GP3, and GP4, which form a glycosylated complex essential for infectivity [97–99]. The evaluation of the neutralization of PRRSV strains by hyperimmune sera revealed significant differences in the sensitivity to neutralization that did not associate with the sequences of previously described linear nAb epitopes nor to N-linked glycosylation sites [100]. Interestingly, a proportion of sera exhibited significant neutralizing activity against all isolates suggesting that these sera contain nAb specific for conserved epitopes that may be poorly exposed and consequently immunogenic in most PRRSV strains. This study highlights our limited understanding of the nAb response to PRRSV but suggests that the identification of the structures recognized by these broadly cross-neutralizing Ab should be a priority for the PRRS research community.

Since the resolution of viremia typically precedes the appearance of nAbs, it is likely that T cell responses are more important to the control and clearance of the virus. Upon PRRSV infection,

virus specific IFN- γ secreting T cells are typically detected in blood after 7–14 days and continue to increase with time long after the resolution of viremia [101], which may reflect the persistence and delayed clearance of antigen in the lungs or lymphoid tissues. Few studies have attempted to characterize the PRRSV-specific T cell response in any detail. CD4 T cells are necessary to drive PRRSV-specific proliferative responses in vitro [102], CD8 T cells are the predominant population expanded by PRRSV stimulation in vitro [103] and both CD4 and CD8 T cells contribute to PRRSV-specific IFN- γ responses [104]. While IFN- γ is known to inhibit PRRSV replication at least in vitro [105, 106], cytotoxic killing of infected cells by CD8 T cell may represent a more effective protective effector mechanism [107], although this has yet to be shown convincingly for PRRSV [103]. CD8 T cells are the dominant population infiltrating the lungs during PRRSV infection [108] and during resolution of infection they are the major source of PRRSV-specific IFN- γ (Graham et al. unpublished data). Investigation into the PRRSV antigen-specificity of T cells is limited and often the phenotype of responding T cells was not discerned. T cell reactivity against both structural and non-structural proteins has been described [104, 109–112]. However more research is required to better define PRRSV T cell antigens and to test whether they may be used to induce protective immune responses.

8.2 Bovine Viral Diarrhea (BVD)

BVD is an economically important infectious disease of cattle caused by infection with the pestivirus BVD virus (BVDV). BVD is characterized by leucopenia, fever, depression, diarrhea, dehydration, anorexia, salivation, nasal discharge, gastrointestinal erosions, and tissue hemorrhages. However, clinical presentation is dependent on a number of factors including virus strain, immune, reproductive, and age status of the host, as well as the presence of co-infections. The majority of BVDV strains cause a transient acute infection in healthy animals that is cleared within 10–14 days. Transient immunosuppression, thought to be a consequence of immune cell death within lymph nodes and gut-associated lymphoid tissue and reduced numbers of circulating leukocytes, increases susceptibility to secondary infection resulting in respiratory and enteric disease [113]. BVDV infection has a major impact on the reproductive success of the host and may result in abortions or the birth of persistently infected calves that play a key role in the epidemiology of BVD [114].

Reflecting its commercial impact BVD neatly illustrates the range of approaches available for vaccine development. There are around 140 registered BVD vaccine products currently in use around the world (www.vetvac.org). These are culture attenuated modified live virus (MLV) or inactivated/killed virus vaccines, formulated as either monovalent BVDV preparations or multiva-

lent vaccines including other pathogens implicated in the bovine respiratory disease complex [115]. Whilst good cross protection is observed against BVDV type 1 strains, the failure of existing BVDV-1 based vaccines to protect against some emerging BVDV type 2 strains has resulted in inclusion of the latter in new vaccine preparations [116]. MLV vaccines are generally thought to be more efficacious since they evoke stronger virus-specific T cell responses, induce high titers of virus neutralizing antibodies and provide a longer duration of protection from clinical disease than inactivated vaccines. However, there are safety concerns over the potential for MLVs to revert to virulence or recombine with field viruses and cause disease. In addition, MLV-vaccinated animals may develop transient viremia and shed vaccine virus [117, 118] and in the case of pregnant animals, MLVs pose the risk of vertical transmission of the vaccine strain that can result in fetal complications or persistent infection [20]. Consequently, MLVs are not licensed in a number of countries including the UK. Neither MLV nor inactivated vaccines allow for differentiation between infected versus vaccinated animals (DIVA), which limits their utility in efforts to eradicate BVDV [119].

The development of next-generation BVD vaccines have primarily focussed on the delivery of the E2 glycoprotein since it represents the major target of the neutralizing antibody response. A variety of approaches have been experimentally evaluated in cattle. These include DNA plasmids [120–122], eukaryotically expressed recombinant protein to preserve conformational epitopes [123–125], or combined heterologous DNA prime-protein boost regimes [126, 127] or via live viral vectors [128–131]. Whilst many of these studies have shown encouraging results, to date none of these vaccines has been licensed.

8.3 *Salmonella*

Salmonella are an economically important cause of diarrhea and systemic infections in animals. Furthermore, they are a zoonotic pathogens and a major cause of diarrhea and systemic disease in humans world-wide, most commonly as a result of consumption of contaminated foodstuffs of animal origin. In the European Union (EU), over 100,000 human cases are reported each year. The European Food Safety Authority (EFSA) has estimated that the overall economic burden of human salmonellosis could be as high as EUR 3 billion a year. Poultry meat, eggs, and egg products are frequently associated with *Salmonella* outbreaks as is pork and contact with infected animals.

Salmonella Enteritidis, Typhimurium, Virchow, Hadar, and Infantis are the most commonly implicated serotypes in human disease in Europe. They are also the most commonly isolated serotypes from poultry. Moreover, *Salmonella* Enteritidis (SE) and to a lesser extent, *Salmonella* Typhimurium (ST) are commonly associated with egg related outbreaks [132]. More recently the

emergence of monophasic strains has complicated diagnosis and indeed vaccination programs [133]. Despite these challenges the use of *Salmonella* vaccines in laying flocks has contributed to a significant reduction in human cases of salmonellosis in the UK. It is widely accepted that vaccination of laying hens confers protection against *Salmonella* infection and results in decreased level of on farm contamination [134] and has contributed to the decline of the *Salmonella* Enteritidis epidemic [135]. Interestingly, in some European countries (Austria, Belgium, The Czech Republic, Germany, and Hungary) vaccination of laying flocks is compulsory. In other countries it is permitted and often recommended (Bulgaria, Belgium, Cyprus, Estonia, France, Greece, Italy, Latvia, Lithuania, The Netherlands, Poland, Portugal, Romania, Slovakia, Slovenia, Spain, and the UK). Conversely, in a few countries vaccination is prohibited (Denmark, Finland, Sweden and Ireland) [136]. In the UK, the majority of commercial scale egg producers subscribe to the British Egg Industry Council (BEIC) Quality Assurance Scheme that provides a code of practice (Lion Code) on farm hygiene and welfare standards, including *Salmonella* vaccination. Vaccination against *Salmonella* began in laying flocks in the UK in 1998 for farms that subscribe to the BEIC Lion Code Scheme [137–139].

At present, both live and inactivated vaccines are commercially available to vaccinate laying flocks [140]. Live vaccines generally confer better protection than the inactivated ones, as they are able to induce both cell mediated and humoral immune responses [136, 141]. However, they may persist in the environment and can present issues for the clinical diagnostic microbiology laboratory. As SE and ST are considered to be the most important serovars for public health in Europe, existing commercially available live and inactivated *Salmonella* vaccines for poultry are generally targeted against one or both of these serovars. In the UK, three live vaccines and two inactivated vaccines are currently available [141–143]. These vaccines are used singularly or combined. To maximize protection, vaccination programs that combine live and inactivated vaccines are sometimes used [144]. Within these vaccination programs, oral vaccines are administered in two or three doses during the rearing period of the pullets and are complemented by one or two injections of killed vaccine (normally close to point of lay) [140]. Currently used vaccination programs are licensed for use against biphasic variants of ST, that is expressing two different flagellar antigenic specificities. Their efficacy against monophasic *Salmonella* Typhimurium (mST), which only express a single flagellar antigenic specificity, has not yet been fully investigated [133, 144]. It is likely that ST vaccines have a similar protective effect for mST as for biphasic ST. However, there are no data available concerning the efficacy of current vaccination programs [145].

A long term goal is to develop vaccines for broiler chickens and also to investigate the use of vectored vaccines that could be used to protect layers, broilers and breeders against a number of patho-

gens, including *Campylobacter*, *E. coli*, *Salmonella*, *Brachyspira*, and *Clostridia* through the use of a single economically viable commercial vaccine.

8.4 Bovine Tuberculosis (*Mycobacterium bovis*)

Bovine tuberculosis (bTB) is a major challenge for livestock globally, a zoonosis, and a significant threat to the cattle industry of England and Wales. Efforts to eradicate the disease from the bovine population are hampered where there is a wildlife reservoir of infection. In England and Wales, the primary wildlife reservoir is the European badger (*Meles meles*), a species protected under national law. In these countries it will take a combination of measures targeting both cattle and wildlife to eradicate bTB. One of the disease control measures being pursued is vaccination, both of badgers and cattle.

At present, the developed vaccine agent for tackling bTB in both cattle and badgers is the live attenuated BCG strain of *M. bovis*. It has been administered to humans since 1927 and is one of the most widely used of all current human vaccines. BCG was licensed for intramuscular vaccination of badgers against bTB by the UK Competent Authority (Veterinary Medicines Directorate) in 2010, following 10 years of studies carried out by the Animal and Plant Health Agency (APHA; formerly the Animal Health and Veterinary Laboratories Agency, AHVLA and the National Wildlife Management Centre of the Food and Environment Research Agency, FERA, now also part of APHA). The licensed vaccine “BadgerBCG” (APHA) has a Limited Marketing Authorization and is currently available for use in the UK by vets and trained lay vaccinators under prescription from a veterinary surgeon.

Use of BadgerBCG over large geographical areas is restricted by the need to trap badgers and inject them, an approach that is relatively expensive and labor intensive. More practical would be an oral form of BCG that could be delivered to badgers in baits. The efficacy of BCG given orally has been demonstrated for cattle, brushtail possums (*Trichosurus vulpecula*) [146], wild boar (*Sus scrofa*) [147], and white-tailed deer (*Odocoileus virginianus*) [148], as well as badgers [149]; each following experimental *M. bovis* infection of captive animals, but also against natural infection in wild possums [150]. However the dose for effective oral administration of BCG is higher than that given parenterally because BCG is killed and degraded in the gut and uptake is relatively inefficient [151]. Experimental studies in possums have suggested that in order to generate immunity it is necessary for oral BCG to retain viability to the point of delivery to the intestine [152]. This has been facilitated through formulation of BCG in a lipid matrix that provides a stable storage and delivery vehicle that protects the live attenuated bacillus during passage through the stomach [146]. Recent success using heat-inactivated *M. bovis* to experimentally vaccinate wild boar orally has increased the number of candidate

oral vaccines for bTB [153, 154]. The Governments of England and Wales have funded research into the development of an oral vaccine for badgers since 2005. Candidate vaccine baits for badgers have been identified and are being evaluated for palatability and efficacy (degree of protection afforded to badgers that consume a vaccine bait), but the formulation of the vaccine itself is only one element. Linked to this is the need for a practical deployment strategy which will maximize uptake among the target badger population and, as far as possible, minimize consumption by other wildlife species or cattle [155].

Regarding cattle, BCG was first demonstrated to be an efficacious vaccine against bTB in 1911 (reviewed in Ref. [156]). Extensive work has been carried out since to optimize the dose and route of administration of BCG vaccine to cattle. Whilst no single vaccine currently offers equal or superior performance to BCG, when used in combination with BCG several offer enhanced protection, e.g., recombinant human adenovirus-vectored mycobacterial antigens [157, 158]. Further assessment of this adenovirus-based strategy as well as development of other approaches should result in vaccine protocols that impart better protection than with BCG alone, and in particular could prolong the duration of immunity. For the foreseeable future, vaccine strategies for bTB in cattle will need to include BCG. The problem with this is that vaccination with BCG sensitizes cattle to tuberculin-based diagnostic tests, including the single intradermal comparative cervical skin test (SICCT). This sensitization is the reason a diagnostic test is needed that will allow accurate detection of infected cattle amongst the vaccinated animals (a so-called DIVA test) and so allow use of a BCG-based vaccine for bTB control alongside a test and slaughter program [159]. A longer-term research goal is the development of vaccines that do not sensitize cattle to tuberculin-based diagnostic tests. This would allow the SICCT to be used alongside vaccination. Close communication and collaboration with research groups working to develop novel human TB vaccines means there is a route to evaluate promising bTB candidates in cattle (embracing a “One Health” approach to vaccine development).

9 Conclusions, Issues, and Needs

Vaccination of veterinary species has a long and successful history and remains an extremely active area of research. Review of PubMed.gov shows that since 2004 there have been an average of over 500 publications each year on veterinary vaccination, reaching their peak over the last 3 years. In writing this overview we have only been able to dip our toe into this vast sea of literature. However, we identified a number of particular issues and cross-cutting needs

that require further attention by the research community, companies, government, and regulators. We summarize these here.

9.1 Vaccine Interference

Vaccine interference is an aspect of veterinary vaccination that requires further evaluation and discussion. The term itself is confusing and is variably interpreted as either referring to the situation where vaccination against one pathogen may compromise the protective immunity induced by vaccination to another, or where the presence of maternally derived antibodies interfere with vaccination in newborn animals. The reader is referred to a helpful review of this subject [160]. The review focuses on experience from human vaccine development and considers vaccine interference in the contexts of the nature and dose of the individual vaccine components, the presence of preexisting immunity, the stage of immunological maturation, genetic and environmental background, vaccine schedule, and mode of vaccine delivery.

The presence of interfering maternal antibodies is a significant consideration in a variety of veterinary vaccine settings. They cause problems for the vaccination of young piglets against influenza, they are the most important obstacle in the establishment of control programs against IBD, they are the primary cause of failure of canine parvovirus type 2 vaccination, and interference by high titers of maternal antibodies prevents the development of an antibody response following vaccination with either a killed or attenuated BVDV vaccine. In countries where control of FMD relies predominantly on vaccination, newborn animals ingest specific anti-FMDV antibodies in the colostrum. This maternally derived antibody provides immediate protection against infection with FMDV but also interferes with the development of active immunity following vaccination leaving young animals susceptible to FMDV infection when maternal antibodies wane. Currently available vaccines for FMD cannot overcome this effect.

9.2 Incomplete Protection and Vaccine Escape Variants

Vaccines rarely produce sterilizing immunity and in some cases exert a powerful selective pressure on pathogens, resulting in the emergence of variants for which the vaccine no longer provides adequate protection. This does not have to arise from the emergence of a new variant but could simply arise from the use of a vaccine that does not provide sufficient cross-protection from one pathogen geno/sero-type to another resulting in the dominance of one type already in circulation. This may be part of the explanation of the failure to control canine distemper virus (CDV) infection in Korea, where at least two different CDV genotypes are in circulation that differ significantly from the genotypes present in vaccine strains [161]. Ensuring a vaccine is effective against a range of circulating strains or variants can be secured by including multiple types in the same vaccine preparation but there is a significant cost to such a strategy. Alternatively autogenous vaccines can be used.

Autogenous vaccines are derived directly from the variant(s) responsible for the disease outbreak, e.g., for *Mycoplasma bovis*. However, this approach cannot prevent the emergence of new variants that escape vaccine-induced immunity through mutation. This is particularly the case for viral pathogens where a high infectious load combined with a low fidelity of genome replication provide an environment for the selection of new variants. There are some good examples of this. First is the TJ strain of PRV, which is a variant of PRV that appears to be emerging along with others in China's pig population in the face of vaccination with the live attenuated vaccine strain, Bartha-K61, which until now has played a critical role in the control of Aujeszky's disease in China [162]. Sequence analysis indicates that these emerging PRV variants cluster to a relatively independent clade in the phylogenetic tree and that protection against these variants with the Bartha-K61 vaccine is incomplete [163]. Second is IB in poultry. IB is caused by an RNA virus that readily undergoes mutation and recombination so that important antigenic variants appear which evade existing vaccine protection. While conventional vaccines work well against homologous types, new strategies are needed to counter this instability. The simple use of two genetically different vaccines to protect against a wide range of heterologous types is now a widespread practice that has been very effective thus far (reviewed in Ref. [164]).

9.3 Mass Application of Vaccines

Mass application of vaccines can be an important consideration in reducing the cost of vaccination by avoiding the need to vaccinate individual animals manually and as a tool in combating disease outbreaks. Mass vaccination of poultry is already performed regularly against a variety of respiratory and gastric pathogens using application by aerosol/spray or in drinking water. Mucosal vaccination has the advantage of inducing both local and systemic immune responses. *In ovo* vaccination offers the advantage of reduced labor costs, mass administration and the induction of an earlier immune response, as described in Subheading 7. For rapid intervention with vaccine during a disease outbreak such as AI, mass application of vaccine is desirable in order to achieve rapid coverage of susceptible birds. An AI vaccine that could be applied by spray or aerosol would be ideal, but aerosol vaccination using live virus is not desirable because of its zoonotic potential and because of the risk for virus reassortment. The next generation of AI vaccines based on recombinant vectors holds out hope for safe and efficacious mass vaccination of susceptible birds as an alternative to preemptive culling in an outbreak [165].

The success of rabies vaccination in the European continent was undoubtedly the result of a safe, effective, and cost-effective vaccine combined with the ease of mass distribution of millions of

edible vaccine baits over large geographical areas. However, there can be a naïve assumption that successful disease eradication is simply a matter of vaccinating enough susceptible animals. The successful eradication of Rinderpest required detailed consideration of the principle of herd immunity and careful application of the vaccine based on detailed epidemiological information. Readers are directed to the excellent review of Roeder and Taylor that sets out the principle of herd immunity and some of the factors which militate against mass vaccination achieving effective levels of herd immunity [166].

9.4 Economics and Incentives

Before embarking on the lengthy and costly road towards a licensed vaccine, initial impact assessment is necessary in order to assess the relative merits of different disease intervention options, including vaccination. This is most likely to be meaningful when it is done in partnership between policy-makers, vaccine manufacturers, funders, and stakeholders. Even when a compelling benefit–cost ratio is found it does not mean a vaccine will necessarily follow [167]. Disease control programs that utilize vaccination but rely on its voluntary uptake are at risk of failure if willingness to vaccinate is too low to reach satisfactory vaccination coverage to stop the spread of the disease. There have been a number of interesting studies exploring the willingness of stakeholders (typically livestock farmers) to vaccinate and the factors that influence this decision. These include studies on Bluetongue in the Netherlands [168], poultry vaccination in developing countries [169] and farmers' confidence in vaccinating badgers as a means to controlling bTB in cattle in the UK [170]. Important lessons emerge from these studies, such as the importance of financial incentives and when they should be applied during a disease control program, the characteristics of the disease, farmers' perceptions of disease risk, the efficacy of the vaccine and other available control options, the availability of resources, and the existence and effectiveness of the veterinary infrastructure, and the wider social and political context. Where there is little incentive to use a vaccine, the best endeavors can fail. An excellent example of this is the vaccination of cattle against *E. coli* O157:H7, reviewed recently by Matthews et al. [171]. These authors point out that in Canada, where the first *E. coli* O157:H7 vaccine was developed and fully licensed, uptake of the vaccine is currently less than 5 % of the market. The authors suggest that this is a likely consequence of the fact that the infection causes no clinical disease in cattle. Therefore, there is little economic incentive for the farmer who bears the cost of vaccination, but receives no direct perceived benefit. For a wider consideration of the economics of veterinary vaccination, the reader is also referred to the review of McLeod and Rushton [172].

9.5 Harmonization

The separation of licensing bodies for human and veterinary medicines has been cited as a reason for delays in the licensing of veterinary vaccines [171]. Whilst the International Conference on Harmonisation of Technical Requirements for Registration of Pharmaceuticals for Human Use (ICH) and its veterinary counterpart, VICH, have been pivotal over the last two decades in harmonizing technical requirements for human and veterinary product registration respectively across Europe, Japan, and the USA there needs to be greater join up between the human and veterinary sectors, not least regarding how the cost might be shared across stakeholders if the conceptual benefits of a “One Health” approach are to become a reality [173]. Progress is being made. For example, STAR-IDAZ (<http://www.star-idaz.net/>) is a recently established network of 24 partners in 18 countries brought together with funding from the European Commission for the purpose of sharing information, improving collaboration on research activities and working towards common research agendas and coordinated research funding on major animal diseases affecting livestock production and/or human health.

References

- Oxford Analytica (2012) The costs of animal disease – a report produced for the International Federation for Animal Health. <http://www.star-idaz.net/wp-content/uploads/2012/12/IFAH-Report-Costs-of-Animal-Disease-2012.pdf>
- Animal and pandemic influenza: a framework for sustaining momentum. Fifth Global Progress Report (2010) United Nations System Influenza Coordination & The World Bank, New York
- National Audit Office (2002) The 2001 outbreak of foot and mouth disease – report by the controller and auditor general
- Watkiss P, Smith A (2011) CBA of foot and mouth disease control strategies: environmental impacts. http://webarchive.nationalarchives.gov.uk/20130402151656/http://archive.defra.gov.uk/foodfarm/farm-animal/diseases/atoz/fmd/documents/environmental_report.pdf
- Baynes RE, Riviere JE (eds) (2014) Strategies for reducing drug and chemical residues in food animals: international approaches to residue avoidance, management, and testing. Wiley, New York, USA
- Wellington EM, Boxall AB, Cross P et al (2013) The role of the natural environment in the emergence of antibiotic resistance in gram-negative bacteria. *Lancet Infect Dis* 13:155–165
- Roeder P, Mariner J, Kock R (2013) Rinderpest: the veterinary perspective on eradication. *Philos Trans R Soc Lond B Biol Sci* 368:20120139
- Cliquet F, Aubert M (2004) Elimination of terrestrial rabies in Western European countries. *Dev Biol* 119:185–204
- Shirley MW, Smith AL, Tomley FM (2005) The biology of avian *Eimeria* with an emphasis on their control by vaccination. *Adv Parasitol* 60:285–330
- La Ragione RM, Woodward MJ, Kumar M et al (2013) Efficacy of a live attenuated *Escherichia coli* O78:K80 vaccine in chickens and turkeys. *Avian Dis* 57:273–279
- Meeusen EN, Walker J, Peters A et al (2007) Current status of veterinary vaccines. *Clin Microbiol Rev* 20:489–510
- Knight-Jones TJ, Edmond K, Gubbins S et al (2014) Veterinary and human vaccine evaluation methods. *Proc Biol Sci* 281:20132839
- News and Reports (2015) Developing the next generation of vaccines. *Vet Rec* 176:297–298
- Garcia JL, Innes EA, Katzer F (2014) Current progress toward vaccines against *Toxoplasma gondii*. *Vaccine Dev Ther* 4:23–37
- Varela NP, Dick P, Wilson J (2013) Assessing the existing information on the efficacy of bovine vaccination against *Escherichia coli* O157:H7 – a systematic review and meta-analysis. *Zoonoses Public Health* 60:253–268
- Lemesre JL, Holzmüller P, Gonçalves RB et al (2007) Long-lasting protection against

- canine visceral leishmaniasis using the LiESAp-MDP vaccine in endemic areas of France: double-blind randomised efficacy field trial. *Vaccine* 25:4223–4234
17. Jalava K, Hensel A, Szostak M et al (2002) Bacterial ghosts as vaccine candidates for veterinary applications. *J Control Release* 85:17–25
 18. Lund A, Bratberg AM, Naess B et al (2014) Control of bovine ringworm by vaccination in Norway. *Vet Immunol Immunopathol* 158: 37–45
 19. Garrido JM, Vazquez P, Molina E et al (2013) Paratuberculosis vaccination causes only limited cross-reactivity in the skin test for diagnosis of bovine tuberculosis. *PLoS One* 8:e80985
 20. Ficken MD, Ellsworth MA, Tucker CM et al (2006) Effects of modified-live bovine viral diarrhea virus vaccines containing either type 1 or types 1 and 2 BVDV on heifers and their offspring after challenge with noncytopathic type 2 BVDV during gestation. *J Am Vet Med Assoc* 228:1559–1564
 21. Huang JM, La Ragione RM, Cooley WA et al (2008) Cytoplasmic delivery of antigens, by *Bacillus subtilis* enhances Th1 responses. *Vaccine* 26:6043–6052
 22. Coppo MJ, Noormohammadi AH, Browning GF et al (2013) Challenges and recent advancements in infectious laryngotracheitis virus vaccines. *Avian Pathol* 42:195–205
 23. Layton SL, Morgan MJ, Cole K et al (2011) Evaluation of *Salmonella*-vectored *Campylobacter* peptide epitopes for reduction of *Campylobacter jejuni* in broiler chickens. *Clin Vaccine Immunol* 18:449–454
 24. Blake DP, Tomley FM (2014) Securing poultry production from the ever-present *Eimeria* challenge. *Trends Parasitol* 30:12–19
 25. La Ragione RM, Patel S, Maddison B et al (2006) Recombinant anti-EspA antibodies block *Escherichia coli* O157:H7-induced attaching and effacing lesions *in vitro*. *Microbes Infect* 8:426–433
 26. Kuhne SA, Hawes WS, La Ragione RM et al (2004) Isolation of recombinant antibodies against EspA and intimin of *Escherichia coli* O157:H7. *J Clin Microbiol* 42:2966–2976
 27. Loza-Rubio E, Rojas-Anaya E (2010) Vaccine production in plant systems – an aid to the control of viral diseases in domestic animals: a review. *Acta Vet Hung* 58:511–522
 28. Jacob SS, Cherian S, Sumithra TG et al (2013) Edible vaccines against veterinary parasitic diseases – current status and future prospects. *Vaccine* 31:1879–1885
 29. Phan HT, Floss DM, Conrad U (2013) Veterinary vaccines from transgenic plants: highlights of two decades of research and a promising example. *Curr Pharm Des* 19:5601–5611
 30. Howard JA (2004) Commercialization of plant-based vaccines from research and development to manufacturing. *Anim Health Res Rev* 5:243–245
 31. Vordermeier M, Hewinson RG (2006) Development of cattle TB vaccines in the UK. *Vet Immunol Immunopathol* 112:38–48
 32. Vordermeier HM, Villarreal-Ramos B, Cockle PJ et al (2009) Viral booster vaccines improve *Mycobacterium bovis* BCG-induced protection against bovine tuberculosis. *Infect Immun* 77:3364–3373
 33. van Rooij EM, Rijsewijk FA, Moonen-Leusen HW et al (2010) Comparison of different prime-boost regimes with DNA and recombinant Orf virus based vaccines expressing glycoprotein D of pseudorabies virus in pigs. *Vaccine* 28:1808–1813
 34. Gomes R, Teixeira C, Teixeira MJ et al (2008) Immunity to a salivary protein of a sand fly vector protects against the fatal outcome of visceral leishmaniasis in a hamster model. *Proc Natl Acad Sci U S A* 105:7845–7850
 35. Lunn DP, Townsend HG (2000) Equine vaccination. *Vet Clin North Am Equine Pract* 16:199–226
 36. Magor KE (2011) Immunoglobulin genetics and antibody responses to influenza in ducks. *Dev Comp Immunol* 35:1008–1016
 37. Koch G, Steensels M, van den Berg T (2009) Vaccination of birds other than chickens and turkeys against avian influenza. *Rev Sci Tech* 28:307–318
 38. Lewis MJ, Wagner B, Woof JM (2008) The different effector function capabilities of the seven equine IgG subclasses have implications for vaccine strategies. *Mol Immunol* 45:818–827
 39. Beutler B, Rehli M (2002) Evolution of the TIR, tolls and TLRs: functional inferences from computational biology. *Curr Top Microbiol Immunol* 270:1–21
 40. Lofthouse SA, Andrews AE, Elhay MJ et al (1996) Cytokines as adjuvants for ruminant vaccines. *Int J Parasitol* 26:835–842
 41. Cox JC, Coulter AR (1997) Adjuvants – a classification and review of their modes of action. *Vaccine* 15:248–256
 42. Aucouturier J, Dupuis L, Ganne V (2001) Adjuvants designed for veterinary and human vaccines. *Vaccine* 19:2666–2672
 43. Singh M, O'Hagan DT (2003) Recent advances in veterinary vaccine adjuvants. *Int J Parasitol* 33:469–478
 44. Wilson-Welder JH, Torres MP, Kipper MJ et al (2009) Vaccine adjuvants: current chal-

- lenges and future approaches. *J Pharm Sci* 98:1278–1316
45. McEntee MC, Page RL (2001) Feline vaccine-associated sarcomas. *J Vet Intern Med* 15:176–182
 46. Mastelic B, Garcon N, Del Giudice G et al (2013) Predictive markers of safety and immunogenicity of adjuvanted vaccines. *Biologicals* 41:458–468
 47. Beasley JC, Atwood TC, Byrne ME et al (2015) A behaviorally-explicit approach for delivering vaccine baits to mesopredators to control epizootics in fragmented landscapes. *PLoS One* 10:e0113206
 48. van Drunen Littel-van den Hurk S, Babiuk SL, Babiuk LA (2004) Strategies for improved formulation and delivery of DNA vaccines to veterinary target species. *Immunol Rev* 199:113–125
 49. Plant KP, Lapatra SE (2011) Advances in fish vaccine delivery. *Dev Comp Immunol* 35:1256–1262
 50. Corbeil S, Kurath G, LaPatra SE (2000) Fish DNA vaccine against infectious hematopoietic necrosis virus: efficacy of various routes of immunisation. *Fish Shellfish Immunol* 10:711–723
 51. von Gersdorff Jorgensen L, Sigh J, Kania PW et al (2012) Approaches towards DNA vaccination against a skin ciliate parasite in fish. *PLoS One* 7:e48129
 52. Shi M, Lam TT, Hon CC et al (2010) Molecular epidemiology of PRRSV: a phylogenetic perspective. *Virus Res* 154:7–17
 53. An TQ, Tian ZJ, Zhou YJ et al (2011) Comparative genomic analysis of five pairs of virulent parental/attenuated vaccine strains of PRRSV. *Vet Microbiol* 149:104–112
 54. Cha SH, Choi EJ, Park JH et al (2006) Molecular characterization of recent Korean porcine reproductive and respiratory syndrome (PRRS) viruses and comparison to other Asian PRRS viruses. *Vet Microbiol* 117:248–257
 55. Chen J, Liu T, Zhu CG et al (2006) Genetic variation of Chinese PRRSV strains based on ORF5 sequence. *Biochem Genet* 44:425–435
 56. Frossard JP, Hughes GJ, Westcott DG et al (2013) Porcine reproductive and respiratory syndrome virus: genetic diversity of recent British isolates. *Vet Microbiol* 162:507–518
 57. Grosse Beilage E, Nathues H, Meemken D et al (2009) Frequency of PRRS live vaccine virus (European and North American genotype) in vaccinated and non-vaccinated pigs submitted for respiratory tract diagnostics in North-Western Germany. *Prev Vet Med* 92:31–37
 58. Li B, Fang L, Xu Z et al (2009) Recombination in vaccine and circulating strains of porcine reproductive and respiratory syndrome viruses. *Emerg Infect Dis* 15:2032–2035
 59. Geldhof MF, Van Breedam W, De Jong E et al (2013) Antibody response and maternal immunity upon boosting PRRSV-immune sows with experimental farm-specific and commercial PRRSV vaccines. *Vet Microbiol* 167:260–271
 60. Geldhof MF, Vanhee M, Van Breedam W et al (2012) Comparison of the efficacy of autogenous inactivated Porcine Reproductive and Respiratory Syndrome Virus (PRRSV) vaccines with that of commercial vaccines against homologous and heterologous challenges. *BMC Vet Res* 8:182
 61. Loemba HD, Mounir S, Mardassi H et al (1996) Kinetics of humoral immune response to the major structural proteins of the porcine reproductive and respiratory syndrome virus. *Arch Virol* 141:751–761
 62. Yoon IJ, Joo HS, Goyal SM et al (1994) A modified serum neutralization test for the detection of antibody to porcine reproductive and respiratory syndrome virus in swine sera. *J Vet Diagn Invest* 6:289–292
 63. Diaz I, Darwich L, Pappaterra G et al (2005) Immune responses of pigs after experimental infection with a European strain of Porcine reproductive and respiratory syndrome virus. *J Gen Virol* 86:1943–1951
 64. Meier WA, Galeota J, Osorio FA et al (2003) Gradual development of the interferon-gamma response of swine to porcine reproductive and respiratory syndrome virus infection or vaccination. *Virology* 309:18–31
 65. Lopez OJ, Oliveira MF, Garcia EA et al (2007) Protection against porcine reproductive and respiratory syndrome virus (PRRSV) infection through passive transfer of PRRSV-neutralizing antibodies is dose dependent. *Clin Vaccine Immunol* 14:269–275
 66. Lopez OJ, Osorio FA (2004) Role of neutralizing antibodies in PRRSV protective immunity. *Vet Immunol Immunopathol* 102:155–163
 67. Osorio FA, Galeota JA, Nelson E et al (2002) Passive transfer of virus-specific antibodies confers protection against reproductive failure induced by a virulent strain of porcine reproductive and respiratory syndrome virus and establishes sterilizing immunity. *Virology* 302:9–20
 68. Ansari IH, Kwon B, Osorio FA et al (2006) Influence of N-linked glycosylation of porcine reproductive and respiratory syndrome virus GP5 on virus infectivity, antigenicity, and abil-

- ity to induce neutralizing antibodies. *J Virol* 80:3994–4004
69. Costers S, Vanhee M, Van Breedam W et al (2010) GP4-specific neutralizing antibodies might be a driving force in PRRSV evolution. *Virus Res* 154:104–113
 70. Kim WI, Lee DS, Johnson W et al (2007) Effect of genotypic and biotypic differences among PRRS viruses on the serologic assessment of pigs for virus infection. *Vet Microbiol* 123:1–14
 71. Kim WI, Yoon KJ (2008) Molecular assessment of the role of envelope-associated structural proteins in cross neutralization among different PRRS viruses. *Virus Genes* 37:380–391
 72. Meulenbergh JJ, van Nieuwstadt AP, van Essen-Zandbergen A et al (1997) Posttranslational processing and identification of a neutralization domain of the GP4 protein encoded by ORF4 of Lelystad virus. *J Virol* 71:6061–6067
 73. Ostrowski M, Galeota JA, Jar AM et al (2002) Identification of neutralizing and nonneutralizing epitopes in the porcine reproductive and respiratory syndrome virus GP5 ectodomain. *J Virol* 76:4241–4250
 74. Plagemann PG (2004) The primary GP5 neutralization epitope of North American isolates of porcine reproductive and respiratory syndrome virus. *Vet Immunol Immunopathol* 102:263–275
 75. Vanhee M, Costers S, Van Breedam W et al (2010) A variable region in GP4 of European-type porcine reproductive and respiratory syndrome virus induces neutralizing antibodies against homologous but not heterologous virus strains. *Viral Immunol* 23:403–413
 76. Vanhee M, Van Breedam W, Costers S et al (2011) Characterization of antigenic regions in the porcine reproductive and respiratory syndrome virus by the use of peptide-specific serum antibodies. *Vaccine* 29:4794–4804
 77. Pirzadeh B, Dea S (1997) Monoclonal antibodies to the ORF5 product of porcine reproductive and respiratory syndrome virus define linear neutralizing determinants. *J Gen Virol* 78:1867–1873
 78. Wissink EH, van Wijk HA, Kroese MV et al (2003) The major envelope protein, GP5, of a European porcine reproductive and respiratory syndrome virus contains a neutralization epitope in its N-terminal ectodomain. *J Gen Virol* 84:1535–1543
 79. Chia MY, Hsiao SH, Chan HT et al (2010) Immunogenicity of recombinant GP5 protein of porcine reproductive and respiratory syndrome virus expressed in tobacco plant. *Vet Immunol Immunopathol* 135:234–242
 80. Prieto C, Martinez-Lobo FJ, Diez-Fuertes F et al (2011) Immunisation of pigs with a major envelope protein sub-unit vaccine against porcine reproductive and respiratory syndrome virus (PRRSV) results in enhanced clinical disease following experimental challenge. *Vet J* 189:323–329
 81. Wang S, Fang L, Fan H et al (2007) Construction and immunogenicity of pseudotype baculovirus expressing GP5 and M protein of porcine reproductive and respiratory syndrome virus. *Vaccine* 25:8220–8227
 82. Xu XG, Wang ZS, Zhang Q et al (2012) Baculovirus as a PRRSV and PCV2 bivalent vaccine vector: baculovirus virions displaying simultaneously GP5 glycoprotein of PRRSV and capsid protein of PCV2. *J Virol Methods* 179:359–366
 83. Barfoed AM, Blixenkroner-Moller M, Jensen MH et al (2004) DNA vaccination of pigs with open reading frame 1-7 of PRRS virus. *Vaccine* 22:3628–3641
 84. Cao J, Wang X, Du Y et al (2010) CD40 ligand expressed in adenovirus can improve the immunogenicity of the GP3 and GP5 of porcine reproductive and respiratory syndrome virus in swine. *Vaccine* 28:7514–7522
 85. Jiang W, Jiang P, Wang X et al (2008) Enhanced immune responses of mice inoculated recombinant adenoviruses expressing GP5 by fusion with GP3 and/or GP4 of PRRS virus. *Virus Res* 136:50–57
 86. Jiang Y, Fang L, Xiao S et al (2007) Immunogenicity and protective efficacy of recombinant pseudorabies virus expressing the two major membrane-associated proteins of porcine reproductive and respiratory syndrome virus. *Vaccine* 25:547–560
 87. Li B, Xiao S, Wang Y et al (2009) Immunogenicity of the highly pathogenic porcine reproductive and respiratory syndrome virus GP5 protein encoded by a synthetic ORF5 gene. *Vaccine* 27:1957–1963
 88. Pirzadeh B, Dea S (1998) Immune response in pigs vaccinated with plasmid DNA encoding ORF5 of porcine reproductive and respiratory syndrome virus. *J Gen Virol* 79:989–999
 89. Roques E, Girard A, St-Louis MC et al (2013) Immunogenic and protective properties of GP5 and M structural proteins of porcine reproductive and respiratory syndrome virus expressed from replicating but non-disseminating adenovectors. *Vet Res* 44:17
 90. Shen G, Jin N, Ma M et al (2007) Immune responses of pigs inoculated with a recombinant

- fowlpox virus coexpressing GP5/GP3 of porcine reproductive and respiratory syndrome virus and swine IL-18. *Vaccine* 25: 4193–4202
91. Wang X, Li J, Jiang P et al (2009) GM-CSF fused with GP3 and GP5 of porcine reproductive and respiratory syndrome virus increased the immune responses and protective efficacy against virulent PRRSV challenge. *Virus Res* 143:24–32
 92. Zheng Q, Chen D, Li P et al (2007) Co-expressing GP5 and M proteins under different promoters in recombinant modified vaccinia virus ankara (rMVA)-based vaccine vector enhanced the humoral and cellular immune responses of porcine reproductive and respiratory syndrome virus (PRRSV). *Virus Genes* 35:585–595
 93. Murtaugh MP, Genzow M (2011) Immunological solutions for treatment and prevention of porcine reproductive and respiratory syndrome (PRRS). *Vaccine* 29: 8192–8204
 94. Dobbe JC, van der Meer Y, Spaan WJ et al (2001) Construction of chimeric arteriviruses reveals that the ectodomain of the major glycoprotein is not the main determinant of equine arteritis virus tropism in cell culture. *Virology* 288:283–294
 95. Prather RS, Rowland RR, Ewen C et al (2013) An intact sialoadhesin (Sn/SIGLEC1/CD169) is not required for attachment/internalization of the porcine reproductive and respiratory syndrome virus. *J Virol* 87:9538–9546
 96. Li J, Murtaugh MP (2012) Dissociation of porcine reproductive and respiratory syndrome virus neutralization from antibodies specific to major envelope protein surface epitopes. *Virology* 433:367–376
 97. Das PB, Vu HL, Dinh PX et al (2011) Glycosylation of minor envelope glycoproteins of porcine reproductive and respiratory syndrome virus in infectious virus recovery, receptor interaction, and immune response. *Virology* 410:385–394
 98. Vu HL, Kwon B, Yoon KJ et al (2011) Immune evasion of porcine reproductive and respiratory syndrome virus through glycan shielding involves both glycoprotein 5 as well as glycoprotein 3. *J Virol* 85:5555–5564
 99. Wissink EH, Kroese MV, van Wijk HA et al (2005) Envelope protein requirements for the assembly of infectious virions of porcine reproductive and respiratory syndrome virus. *J Virol* 79:12495–12506
 100. Martinez-Lobo FJ, Diez-Fuertes F, Simarro I et al (2011) Porcine reproductive and respiratory syndrome virus isolates differ in their susceptibility to neutralization. *Vaccine* 29: 6928–6940
 101. Mateu E, Diaz I (2008) The challenge of PRRS immunology. *Vet J* 177:345–351
 102. Bautista EM, Molitor TW (1997) Cell-mediated immunity to porcine reproductive and respiratory syndrome virus in swine. *Viral Immunol* 10:83–94
 103. Costers S, Lefebvre DJ, Goddeeris B et al (2009) Functional impairment of PRRSV-specific peripheral CD3+CD8high cells. *Vet Res* 40:46
 104. Mokhtar H, Eck M, Morgan SB et al (2014) Proteome-wide screening of the European porcine reproductive and respiratory syndrome virus reveals a broad range of T cell antigen reactivity. *Vaccine* 32:6828–6837
 105. Bautista EM, Molitor TW (1999) IFN gamma inhibits porcine reproductive and respiratory syndrome virus replication in macrophages. *Arch Virol* 144:1191–1200
 106. Rowland RR, Robinson B, Stefanick J et al (2001) Inhibition of porcine reproductive and respiratory syndrome virus by interferon-gamma and recovery of virus replication with 2-aminopurine. *Arch Virol* 146:539–555
 107. Graham BS (2013) Advances in antiviral vaccine development. *Immunol Rev* 255:230–242
 108. Samsom JN, de Bruin TG, Voermans JJ et al (2000) Changes of leukocyte phenotype and function in the broncho-alveolar lavage fluid of pigs infected with porcine reproductive and respiratory syndrome virus: a role for CD8(+) cells. *J Gen Virol* 81:497–505
 109. Burgara-Estrella A, Diaz I, Rodriguez-Gomez IM et al (2013) Predicted peptides from non-structural proteins of porcine reproductive and respiratory syndrome virus are able to induce IFN-gamma and IL-10. *Viruses* 5:663–677
 110. Diaz I, Pujols J, Ganges L et al (2009) In silico prediction and *ex vivo* evaluation of potential T-cell epitopes in glycoproteins 4 and 5 and nucleocapsid protein of genotype-I (European) of porcine reproductive and respiratory syndrome virus. *Vaccine* 27:5603–5611
 111. Parida R, Choi IS, Peterson DA et al (2012) Location of T-cell epitopes in nonstructural proteins 9 and 10 of type-II porcine reproductive and respiratory syndrome virus. *Virus Res* 169:13–21
 112. Vashisht K, Goldberg TL, Husmann RJ et al (2008) Identification of immunodominant T-cell epitopes present in glycoprotein 5 of the North American genotype of porcine reproductive and respiratory syndrome virus. *Vaccine* 26:4747–4753

113. Bolin SR (2002) Bovine viral diarrhoea viruses in mixed infections. In: Brogen KM, Guthmiller JM (eds) Polymicrobial diseases. ASM Press, Washington, DC, pp 33–50
114. Fray MD, Paton DJ, Alenius S (2000) The effects of bovine viral diarrhoea virus on cattle reproduction in relation to disease control. *Anim Reprod Sci* 60–61:615–627
115. Allen JW, Viel L, Bateman KG et al (1992) Serological titers to bovine herpesvirus 1, bovine viral diarrhoea virus, parainfluenza 3 virus, bovine respiratory syncytial virus and *Pasteurella haemolytica* in feedlot calves with respiratory disease: associations with bacteriological and pulmonary cytological variables. *Can J Vet Res* 56:281–288
116. Ridpath JF (2005) Practical significance of heterogeneity among BVDV strains: impact of biotype and genotype on U.S. control programs. *Prev Vet Med* 72:17–30
117. Fulton RW, Saliki JT, Burge LJ et al (2003) Humoral immune response and assessment of vaccine virus shedding in calves receiving modified live virus vaccines containing bovine herpesvirus-1 and bovine viral diarrhoea virus 1a. *J Vet Med B Infect Dis Vet Public Health* 50:31–37
118. Grooms DL, Brock KV, Ward LA (1998) Detection of cytopathic bovine viral diarrhoea virus in the ovaries of cattle following immunization with a modified live bovine viral diarrhoea virus vaccine. *Vet Diagn Invest* 10:130–134
119. van Oirschot JT, Brusckhe CJ, van Rijn PA (1999) Vaccination of cattle against bovine viral diarrhoea. 0378-1135 (Print) *Comparative Study Journal Article Research Support, Non-US Gov't* 64:169–183
120. Harpin S, Hurley DJ, Mbikay M et al (1999) Vaccination of cattle with a DNA plasmid encoding the bovine viral diarrhoea virus major glycoprotein E2. *J Gen Virol* 80(Pt 12):3137–3144
121. Liang R, van den Hurk JV, Zheng C et al (2005) Immunization with plasmid DNA encoding a truncated, secreted form of the bovine viral diarrhoea virus E2 protein elicits strong humoral and cellular immune responses. *Vaccine* 23:5252–5262
122. Nobiron I, Thompson I, Brownlie J et al (2003) DNA vaccination against bovine viral diarrhoea virus induces humoral and cellular responses in cattle with evidence for protection against viral challenge. *Vaccine* 21: 2082–2092
123. Bolin SR, Ridpath JF (1996) Glycoprotein E2 of bovine viral diarrhoea virus expressed in insect cells provides calves limited protection from systemic infection and disease. *Arch Virol* 141:1463–1477
124. Chimeno Zoth S, Leunda MR, Odeon A et al (2007) Recombinant E2 glycoprotein of bovine viral diarrhoea virus induces a solid humoral neutralizing immune response but fails to confer total protection in cattle. *Braz J Med Biol Res* 40:813–818
125. Thomas C, Young NJ, Heaney J et al (2009) Evaluation of efficacy of mammalian and baculovirus expressed E2 subunit vaccine candidates to bovine viral diarrhoea virus. *Vaccine* 27:2387–2393
126. Liang R, van den Hurk JV, Babiuk LA et al (2006) Priming with DNA encoding E2 and boosting with E2 protein formulated with CpG oligodeoxynucleotides induces strong immune responses and protection from Bovine viral diarrhoea virus in cattle. *J Gen Virol* 87:2971–2982
127. Liang R, van den Hurk JV, Landi A et al (2008) DNA prime protein boost strategies protect cattle from bovine viral diarrhoea virus type 2 challenge. *J Gen Virol* 89:453–466
128. Baxi MK, Deregt D, Robertson J et al (2000) Recombinant bovine adenovirus type 3 expressing bovine viral diarrhoea virus glycoprotein E2 induces an immune response in cotton rats. *Virology* 278:234–243
129. Elahi SM, Shen SH, Talbot BG et al (1999) Recombinant adenoviruses expressing the E2 protein of bovine viral diarrhoea virus induce humoral and cellular immune responses. *FEMS Microbiol Lett* 177:159–166
130. Mehdy Elahi S, Bergeron J, Nagy E et al (1999) Induction of humoral and cellular immune responses in mice by a recombinant fowlpox virus expressing the E2 protein of bovine viral diarrhoea virus. *FEMS Microbiol Lett* 171:107–114
131. Toth RL, Nettleton PF, McCrae MA (1999) Expression of the E2 envelope glycoprotein of bovine viral diarrhoea virus (BVDV) elicits virus-type specific neutralising antibodies. *Vet Microbiol* 65:87–101
132. EFSA Panel on Animal Health and Welfare (2013) Scientific opinion on field trials for bovine tuberculosis vaccination. *EFSA J* 11: 3475
133. Martelli F, Gosling R, Kennedy E et al (2014) Characterization of the invasiveness of monophasic and aphasic *Salmonella* Typhimurium strains in 1-day-old and point-of-lay chickens. *Avian Pathol* 43:269–275
134. Van Immerseel F, Methner U, Rychlik I et al (2005) Vaccination and early protection against non-host-specific *Salmonella* serotypes in poultry: exploitation of innate immunity and microbial activity. *Epidemiol Infect* 133:959–978

135. Lane CR, LeBaigue S, Esan OB et al (2014) *Salmonella enterica* serovar Enteritidis, England and Wales, 1945-2011. *Emerg Infect Dis* 20:1097-1104
136. Galis A, Marcq C, Marlier D et al (2013) Control of *Salmonella* contamination of shell eggs – preharvest and postharvest methods: a review. *Compr Rev Food Sci Food Saf* 12:155-182
137. Cogan TA, Humphrey TJ (2003) The rise and fall of *Salmonella* Enteritidis in the UK. *J Appl Microbiol* 94(Suppl):114S-119S
138. O'Brien SJ (2012) The “Decline and Fall” of Nontyphoidal *Salmonella* in the United Kingdom. *Clin Infect Dis* 56:705-710
139. Ward LR, Threlfall J, Smith HR et al (2000) *Salmonella enteritidis* epidemic. *Science* 287:1753-1754
140. EFSA (2004) The use of vaccines for the control of *Salmonella* in poultry. *EFSA J* 114:1-74
141. Gantois I, Ducatelle R, Timbermont L et al (2006) Oral immunisation of laying hens with the live vaccine strains of TAD *Salmonella* vac E and TAD *Salmonella* vac T reduces internal egg contamination with *Salmonella* Enteritidis. *Vaccine* 24:6250-6255
142. Clifton-Hadley FA, Breslin M, Venables LM et al (2002) A laboratory study of an inactivated bivalent iron restricted *Salmonella enterica* serovars Enteritidis and Typhimurium dual vaccine against Typhimurium challenge in chickens. *Vet Microbiol* 89:167-179
143. Springer S, Lindner T, Ahrens M et al (2011) Duration of immunity induced in chickens by an attenuated live *Salmonella enteritidis* vaccine and an inactivated *Salmonella enteritidis/typhimurium* vaccine. *Berl Munch Tierarztl Wochenschr* 124:89-93
144. Arnold ME, Gosling RJ, La Ragione RM et al (2014) Estimation of the impact of vaccination on faecal shedding and organ and egg contamination for *Salmonella* Enteritidis, *Salmonella* Typhimurium and monophasic *Salmonella* Typhimurium. *Avian Pathol* 43:155-163
145. Davies R, Mueller-Doblies D (2013) Observations on the occurrence and persistence of monophasic *Salmonella* Typhimurium (S. 4, 5, 12:i:-) in poultry farms. In: I3S International Symposium *Salmonella* and Salmonellosis, St Malo, France, pp 281-282
146. Cross ML, Henderson RJ, Lambeth MR et al (2009) Lipid-formulated BCG as an oral-bait vaccine for tuberculosis: vaccine stability, efficacy, and palatability to brushtail possums (*Trichosurus vulpecula*) in New Zealand. *J Wildlife* 45:754-765
147. Ballesteros C, Garrido JM, Vicente J et al (2009) First data on Eurasian wild boar response to oral immunization with BCG and challenge with a *Mycobacterium bovis* field strain. *Vaccine* 27:6662-6668
148. Nol P, Palmer MV, Waters WR et al (2008) Efficacy of oral and parenteral routes of *Mycobacterium bovis* bacille Calmette-Guerin vaccination against experimental bovine tuberculosis in white-tailed deer (*Odocoileus virginianus*): a feasibility study. *J Wildlife* 44:247-259
149. Murphy D, Costello E, Aldwell FE et al (2014) Oral vaccination of badgers (*Meles meles*) against tuberculosis: comparison of the protection generated by BCG vaccine strains Pasteur and Danish. *Vet J* 200:362-367
150. Tompkins DM, Ramsey DS, Cross ML et al (2009) Oral vaccination reduces the incidence of tuberculosis in free-living brushtail possums. *Proc Biol Sci* 276:2987-2995
151. Mortatti RC, Maia LC, Fonseca LS (1987) Absorption of *Mycobacterium bovis* BCG administered by the oral route. *Vaccine* 5:109-114
152. Buddle BM, Aldwell FE, Keen DL et al (2006) Oral vaccination of brushtail possums with BCG: Investigation into factors that may influence vaccine efficacy and determination of duration of protection. *N Z Vet J* 54:224-230
153. Beltran-Beck B, Romero B, Sevilla IA et al (2014) Assessment of an oral *Mycobacterium bovis* BCG vaccine and an inactivated *M. bovis* preparation for wild boar in terms of adverse reactions, vaccine strain survival, and uptake by non-target species. *Clin Vaccine Immunol* 21:12-20
154. Garrido JM, Sevilla IA, Beltran-Beck B et al (2011) Protection against tuberculosis in Eurasian wild boar vaccinated with heat-inactivated *Mycobacterium bovis*. *PLoS One* 6:e24905
155. Robertson A, McDonald RA, Delahay RJ et al (2015) Exposure of nontarget wildlife to candidate TB vaccine baits deployed for European badgers. *Eur J Wildl Res* 61:263-269
156. Waters WR, Palmer MV, Buddle BM et al (2012) Bovine tuberculosis vaccine research: historical perspectives and recent advances. *Vaccine* 30:2611-2622
157. Buddle BM, Wedlock DN, Denis M et al (2011) Update on vaccination of cattle and wildlife populations against tuberculosis. *Vet Microbiol* 151:14-22
158. Dean G, Whelan A, Clifford D et al (2014) Comparison of the immunogenicity and protection against bovine tuberculosis following immunization by BCG-priming and boosting with adenovirus or protein based vaccines. *Vaccine* 32:1304-1310

159. Vordermeier M, Jones GJ, Whelan AO (2011) DIVA reagents for bovine tuberculosis vaccines in cattle. *Expert Rev Vaccines* 10:1083–1091
160. Vidor E (2007) The nature and consequences of intra- and inter-vaccine interference. *J Comp Pathol* 137(Suppl 1):S62–S66
161. Bae CW, Lee JB, Park SY et al (2013) Deduced sequences of the membrane fusion and attachment proteins of canine distemper viruses isolated from dogs and wild animals in Korea. *Virus Genes* 47:56–65
162. Wang CH, Yuan J, Qin HY et al (2014) A novel gE-deleted pseudorabies virus (PRV) provides rapid and complete protection from lethal challenge with the PRV variant emerging in Bartha-K61-vaccinated swine population in China. *Vaccine* 32:3379–3385
163. An TQ, Peng JM, Tian ZJ et al (2013) Pseudorabies virus variant in Bartha-K61-vaccinated pigs, China 2012. *Emerg Infect Dis* 19:1749–1755
164. Jones RC (2010) Viral respiratory diseases (ILT, aMPV infections, IB): are they ever under control? *Br Poultry Sci* 51:1–11
165. van den Berg T, Lambrecht B, Marche S et al (2008) Influenza vaccines and vaccination strategies in birds. *Comp Immunol Microbiol Infect Dis* 31:121–165
166. Roeder PL, Taylor WP (2007) Mass vaccination and herd immunity: cattle and buffalo. *Rev Sci Tech* 26:253–263
167. Kristjanson PM, Swallow BM, Rowlands GJ et al (1999) Measuring the costs of African animal trypanosomosis: the potential benefits of control and returns to research. *Agr Syst* 59:79–98
168. Rat-Aspert O, Fourichon C (2010) Modelling collective effectiveness of voluntary vaccination with and without incentives. *Prev Vet Med* 93:265–275
169. Alders RG, Bagnol B, Young MP et al (2007) Challenges and constraints to vaccination in developing countries. *Dev Biol* 130:73–82
170. Enticott G, Maye D, Ilbery B et al (2012) Farmers' confidence in vaccinating badgers against bovine tuberculosis. *Vet Rec* 170:204
171. Matthews L, Reeve R, Gally DL et al (2013) Predicting the public health benefit of vaccinating cattle against *Escherichia coli* O157. *Proc Natl Acad Sci U S A* 110:16265–16270
172. McLeod A, Rushton J (2007) Economics of animal vaccination. *Rev Sci Tech* 26:313–326
173. Zinsstag J, Schelling E, Wyss K et al (2005) Potential of cooperation between human and animal health to strengthen health systems. *Lancet* 366:2142–2145

Part II

Vaccines for Farm Animals

Chapter 2

Development of *Mycoplasma hyopneumoniae* Recombinant Vaccines

Silvana Beutinger Marchioro, Simone Simionatto, and Odir Dellagostin

1 Introduction

Respiratory diseases are among the most important health problems associated with swine production. *Mycoplasma hyopneumoniae* is the principal etiological agent responsible for enzootic pneumonia (EP), a chronic respiratory disease in pigs. This infection is highly prevalent (ranging between 38 and 100 %), in almost all areas of pig production worldwide, and *M. hyopneumoniae* infections cause significant economic losses [1]. The control of EP should focus on the optimization of management practices and housing conditions [2], the use of antimicrobial medication [3], and vaccination. Several commercial vaccines consisting of the inactivated adjuvanted whole cell lysates of *M. hyopneumoniae* are available and used worldwide. Though these vaccines have been proven to be effective in reducing the clinical signs, they provide only partial protection against the development of lesions [4].

Recombinant DNA technology could be employed to overcome problems encountered with conventional vaccines. The small genome of this pathogen, as well as the limited number of secreted or surface proteins, favors the use of reverse vaccinology approach [5]. However, *Mycoplasma* sp. uses an unusual genetic code. The amino acid tryptophan is not encoded by TGG, as in most organisms, but by TGA, which is a stop codon [6]. This difference has hampered the expression of genes of *M. hyopneumoniae* containing TGA codons in *Escherichia coli*, the most attractive system used for production of recombinant proteins [7]. However, mutations that can replace TGA codons with TGG have been used to solve this problem [8].

Constant effort is being directed toward the investigation of new vaccines that may offer a better protection against *M. hyopneumoniae* infections. Several studies have evaluated recombinant proteins of *M. hyopneumoniae*, in different forms of administration and formulations, seeking to develop more effective vaccines against EP. Some of them were evaluated individually [9, 10], and others were associated with attenuated bacterial or viral vectors [11–18], fused to mucosal adjuvants [19, 20], and also evaluated as a cocktail of antigens [21, 22]. Only a few of these recombinant proteins were used in challenge experiments in pigs; most of them were evaluated only in mice. Differences in the immunity induced by these antigens were observed, which can be influenced by differences in the vaccine construction, the route of immunization, the correct folding, and/or other posttranslational modification that may contribute to the ability to generate antibodies by the antigens [23]. However, these evaluations suggest that these new vaccine approaches may represent promising new strategies and may be economically feasible to control EP.

2 Materials

2.1 Strains and Plasmids

1. *M. hyopneumoniae* strain for genomic DNA extraction.
2. *E. coli* TOP10 (Invitrogen, USA) as a host strain.
3. *E. coli* BL21 (DE3) RIL (Invitrogen, USA) as expression strain.
4. Vector Champion pET200D/TOPO (Invitrogen, USA) for cloning and expression.

2.2 Bioinformatics Software

1. Bioinformatics softwares: Pfam, SignalP, PROSITE, and NNPREPDICTION for in silico selection of coding sequences.
2. Vector NTI® 11 (Invitrogen, USA) for primer design.

2.3 Cloning of *M. hyopneumoniae* Coding Sequences

1. Genomic DNA extracted of *M. hyopneumoniae* strains.
2. GFX genomic blood DNA and gel band purification kit (GE Healthcare, USA).
3. PCR reagents: 50 ng of *M. hyopneumoniae* genomic DNA, 0.2 mM dNTP, 2.5 mM MgCl₂, 10 pmol of each primer, 2.5 units of Platinum Pfx DNA polymerase, 1× reaction buffer, and 1× enhancer buffer (Invitrogen, USA).
4. Champion pET200D/TOPO (Invitrogen, USA) expression vector.
5. Restriction enzymes and 10× buffers (Invitrogen, USA).
6. T4 DNA ligase and 10× buffers (Invitrogen, USA).
7. Agarose, loading dye, and nucleic acid stain suitable for gel electrophoresis (Invitrogen, USA).

8. Agarose gel electrophoresis (for 150 ml of 1.0 % agarose gel, use 1.5 g of ultrapure agarose with 150 ml of 1× TBE. Prepare 1 l of 1× TBE solution in ultrapure water with 10.8 g of Tris base, 5.5 g of boric acid, and 4 ml of EDTA 0.5 M, and adjust to pH 8.0).
9. Gel documentation system (Loccus, Brazil) or equivalent.
10. QIAquick Gel Extraction Kit (Qiagen, [Germany](#)).
11. *E. coli* TOP10 electro-competent cells (Invitrogen, USA).
12. Electroporator: Bio-Rad Gene Pulser®II, BTX® ECM® 630 (Bio-Rad, USA) or equivalent.
13. Electroporation cuvette of 0.1 cm (Bio-Rad, USA) or equivalent.
14. Luria–Bertani (LB) medium (to 900 ml of distilled H₂O, add 10 g Bacto Tryptone, 5 g Bacto Yeast Extract, 10 g NaCl. Adjust to 1 l with distilled H₂O. Sterilize by autoclaving and store up to 3 months at room temperature).
15. Kanamycin (100 µg/ml) (Sigma-Aldrich, USA).
16. Phenol–chloroform (Sigma-Aldrich, USA) and lysis buffer (sample buffer 6× [24]: 3 ml glycerol (30 %); 25 mg bromophenol blue (0.25 %); dH₂O to 10 ml. Lysis buffer: 100 µl of sample buffer + 900 µl of dH₂O + 1 µl RNase).
17. DYEnamic ET Terminator Cycle Sequencing Kit (GE Healthcare, USA).
18. MegaBACE 500 (GE Healthcare, USA) or equivalent.
19. Shaking and non-shaking incubator at 37 °C (DeLeo, Brazil) or equivalent.
20. Illustra plasmidPrep Mini Spin Kit (GE Healthcare, USA).

2.4 Expression of Recombinant Proteins and Solubility Testing

1. *E. coli* BL21 (DE3) RIL (Invitrogen, USA) expression competent cells.
2. Recombinant plasmid DNA.
3. Solid and liquid LB medium (to 900 ml of distilled H₂O, add 10 g Bacto Tryptone, 5 g Bacto Yeast Extract, 10 g NaCl. Adjust to 1 l with distilled H₂O. Sterilize by autoclaving and store up to 3 months at room temperature. For solid medium, add 1.5 % of agar).
4. Kanamycin (100 µg/ml) (Sigma-Aldrich, USA).
5. Isopropylthio-b-d-galactosidase (IPTG) (Invitrogen, USA) with a final concentration of 0.3 mM.
6. Sterile inoculation loops.
7. Sterile round-bottom snap-cap tubes of 15 ml (Sigma-Aldrich, USA).
8. UV spectrophotometer (Biochrom, USA) or equivalent.

9. Shaking and non-shaking incubator (DeLeo/Brazil).
10. Phosphate-buffered saline 0.1 M (PBS, pH 7.4).
11. Loading buffer: (5×) (62.5 mM Tris-HCl pH 6.8, 10 % glycerol, 5 % 2β-mercaptoethanol, 2 % SDS).
12. Sodium dodecyl sulfate–polyacrylamide gel electrophoresis (SDS–PAGE) 12 % running gel: 10.2 ml of H₂O; 7.5 ml of 1.5 M Tris-HCl pH 8.8; 0.15 ml of 20 % (w/v) SDS; 12.0 ml of acrylamide/bis-acrylamide (30 %/0.8 % w/v); 0.15 ml of 10 % (w/v) ammonium persulfate (APS); 0.02 ml of TEMED. Cast gel within a 7.25 cm × 10 cm × 1.5 mm gel cassette. Allow space for stacking the gel and gently overlay with water. Prepare the stacking gel by mixing 3 ml of H₂O; 1.25 ml of 0.5 M Tris-HCl pH 6.8; 0.1 ml of 20 % (w/v) SDS; 0.67 ml of acrylamide/bis-acrylamide (30 %/0.8 % w/v); 0.04 ml of 10 % (w/v) ammonium persulfate (APS); 0.005 ml of TEMED. Insert a ten-well gel comb immediately without introducing air bubbles.
13. Coomassie Blue (Sigma-Aldrich, USA).
14. Lysozyme 1 mg/ml (Sigma-Aldrich, USA).
15. Phenylmethanesulfonyl fluoride (PMSF) 1 mM (Sigma-Aldrich, USA).
16. Microcentrifuges (Thermo Scientific, USA).
17. Ultrasonic probe sonicator (Qsonica LLC, USA).

2.5 Solubilization and Purification of Recombinant Proteins

1. Buffer A: (200 mM NaH₂PO₄, 500 mM NaCl, 5 mM imidazole, pH 8.0) containing 8 M urea (Sigma-Aldrich, USA).
2. HisTrap™ HP 1 ml columns prepacked with precharged Ni Sepharose™ (GE Healthcare, USA).
3. Buffer B: (200 mM NaH₂PO₄, 500 mM NaCl, 500 mM imidazole) containing 8 M urea (Sigma-Aldrich, USA).
4. Sodium dodecyl sulfate–polyacrylamide gel electrophoresis (SDS–PAGE) 12 % (*see* Subheading 2.4).
5. PBS (pH 7.4) containing 0.05 % Triton X-100 (Sigma-Aldrich, USA).
6. Refrigerated ultracentrifuge (Thermo Scientific™ Sorvall™ WX Floor, USA).
7. ÄKTAprime™ automated liquid chromatography system (GE Healthcare, USA).
8. Dialysis tubing membrane (Sigma-Aldrich, USA).

2.6 Immunoblotting Components

1. Nitrocellulose membranes (GE Healthcare, USA).
2. Western blot transfer buffer (0.025 M Tris, 0.192 M glycine, and 20 % ethanol) (Sigma-Aldrich, USA).

3. PBS containing 0.05 % Tween-20 (PBST) (Sigma-Aldrich, USA).
4. Blocking solution (5 % powdered milk in PBS). Store at 4 °C.
5. Diluent solution (5 % powdered milk in PBST). Store at 4 °C.
6. Mini-PROTEAN® 3 system glass plates (Bio-Rad, USA) or equivalent.
7. Whatman no. 3 filter paper (GE Healthcare, USA) or similar.
8. [Monoclonal antibodies anti-6× His IgG](#) (Sigma-Aldrich, USA).
9. 4-Chloro-1-naphthol.
10. Hydrogen peroxidase.
11. BenchMark™ Prestained Protein Ladder (Invitrogen, USA) or equivalent.

2.7 Vaccine Formulation

1. BCA™ protein assay kit (Pierce, USA).
2. Purified recombinant proteins.
3. Aluminum hydroxide or similar adjuvants.

3 Methods

3.1 Selection of Coding Sequences and Primer Design

1. Coding DNA sequences (CDS) encoding surface-exposed, secreted proteins, related to pathogenesis with up to three tryptophan (TGA) codons should be selected by bioinformatics software.
2. Primers are designed based on GenBank genome sequences by Vector NTI® 11.
3. The mutagenesis procedure required four oligonucleotides: two flanking primers, which are positioned upstream (U) and downstream (D) of the mutation site, and two mutagenic primers, forward (FM) and reverse mutagenic (RM) with at least a 15 bp overlap between adjacent fragments. The mutation site should be located in the middle of the mutagenic primers.
4. Cloning into Champion pET200D/TOPO His-tag expression vector is necessary to add four bases (CACC) in the forward flanking primer to anneal a complementary overhang (GTGG) in the vector.

3.2 The Site-Directed Mutagenesis Method

1. Genomic DNA extraction of *M. hyopneumoniae* strains can be performed with GFX genomic blood DNA purification kit.
2. Site-directed mutagenesis is carried out using a two-step PCR procedure to replace the TGA codons using an overlap extension PCR method [4].
3. The first step, two simultaneous PCR reactions are performed. One reaction is performed with a primer pair that included the

U primer and the RM primer; the other reaction contained the D primer and the FM primer. PCR reactions are carried out with a final volume of 25 μ l.

4. PCR reactions are carried out using 50 ng of *M. hyopneumoniae* genomic DNA, 0.2 mM dNTPs, 2.5 mM MgCl₂, 10 pmol of each primer, 2 units of Platinum® Pfx DNA polymerase (extension temperature 68 °C), and 1 \times reaction buffer in a 25 μ l reaction volume. For amplification, a Mastercycler gradient is used with the following settings: 7 min at 95 °C followed by 30 cycles of 60 s at 95 °C, 60 s at 55 °C and 60 s at 68 °C, and then a final extension of 7 min at 68 °C.
5. PCR products are analyzed by 1 % agarose gel electrophoresis and gel band purified using the GFX PCR DNA and gel band purification kit, according to the manufacturer's instructions. To obtain full-length mutated fragments, the two products from the first PCR are mixed in equimolar concentrations (approximately 0.4–0.8 pmol) and used as templates during the second PCR reaction, with the U and D primers. The reaction is performed using the same conditions as first PCR.

3.3 Cloning of *M. hyopneumoniae* Coding Sequences

1. The overlap extension PCR yields a full-length DNA fragment that is ligated into Champion pET200D/TOPO expression vector following the manufacturer's instructions (Fig. 1). The vector contains the T7 promoter and allows expression of the recombinant protein fused to His-tag at the N-terminus.
2. The ligation products are transformed (*see Note 1*) into *E. coli* TOP10 electro-competent cells following the manufacturer's instructions.
3. Recombinant clones are identified by lysis cells (*see Note 2*).
4. The identity of the inserts is determined by DNA sequencing (*see Note 3*) using the DYEnamic ET Dye Terminator Cycle Sequencing Kit for MegaBACE DNA Analysis Systems—MegaBACE 500.

3.4 Expression of Recombinant Proteins and Solubility Testing

1. Recombinant plasmids are transformed into *E. coli* BL21(DE3) RIL expression competent cells by electroporation following a standard method (*see Note 1*).
2. One recombinant clone of each plasmid is used to inoculate 5 ml of Luria–Bertani (LB) medium containing 100 μ g/ml kanamycin, incubated in shaker at 37 °C and 1 \times g until OD₆₀₀=0.6.
3. Expression of the recombinant proteins is induced with IPTG with a final concentration of 0.3 mM and the culture is grown at 37 °C for 3 h.
4. A volume of 500 μ l of culture growth is centrifuged at 14,000 \times g for 2 min, and the pellet is solubilized in 80 μ l of 0.1 M phosphate-buffered saline (PBS, pH 7.4) containing

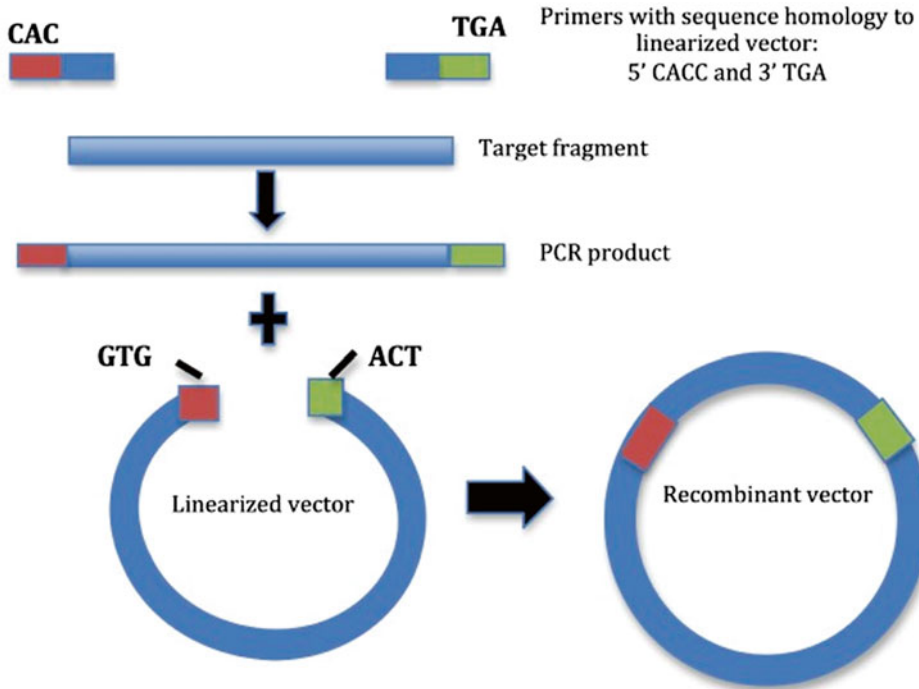

Fig. 1 Schematic representation of the cloning of *Mycoplasma hyopneumoniae* coding sequences into Champion pET200D/TOPO His-tag expression vector

20 μ l of 5 \times loading buffer. After boiling for 10 min, a volume of 8 μ l of the supernatant is submitted to 12 % SDS-PAGE (*see Note 4*).

5. Expression of recombinant proteins is identified by staining the gel with Coomassie Blue and visualization of an extra protein band of the predicted size.
6. Clones that expressed the recombinant protein are tested regarding the solubility of the protein. For that, a volume of 2 ml of culture growth is centrifuged at 14,000 $\times g$ for 2 min, and the pellet is solubilized in 500 μ l of PBS containing 1 mg/ml lysozyme and 1 mM PMSF. Cells are lysed by sonication (6 $\times 10$ s pulses) in ice-water bath. The soluble and insoluble fractions are separated by centrifugation at 10,000 $\times g$ for 5 min at 4 $^{\circ}$ C. Soluble proteins remained in the supernatant and insoluble proteins are found in the pellet. Both fractions are submitted to 12 % SDS-PAGE (*see Note 4*) for identification of the protein localization.

3.5 Solubilization and Purification of Recombinant Proteins

1. Proteins expressed in *E. coli* as insoluble particles are solubilized with 8 M urea. For solubilization, a pellet obtained from a 500 ml culture (approximately 1 g cells) is solubilized in 30 ml of buffer A. After incubation at 4 $^{\circ}$ C for 60 min, the cell lysate is centrifuged at 14,000 $\times g$ for 60 min at 4 $^{\circ}$ C (*see Note 5*).

2. The recombinant proteins are purified from the supernatant by affinity chromatography using HisTrap™ HP 1 ml columns prepacked with precharged Ni Sepharose™ using the ÄKTAprime™ automated liquid chromatography system. The recombinant protein is eluted with a linear gradient from 5 to 500 mM imidazole. Fractions of 1 ml are collected and 5 µl is applied to 12 % SDS–PAGE (*see Note 4*).
3. Fractions of 10 ml containing the recombinant protein are pooled in a dialysis tubing membrane (Sigma-Aldrich, USA), with a concentration ranging from 0.6 to 16 mg and submitted to an extended stepwise dialysis in 10 l of PBS (pH 7.4) at 4 °C for 120 h, containing 0.05 % Triton X-100 to remove imidazole and urea and to promote protein refolding.
4. Purification of soluble proteins is performed under non-denaturing conditions with buffer A without urea or *N*-lauroylsarcosine.

3.6 Electrophoretic Transfer

1. Immediately following SDS–PAGE, when the dye front reaches the end of the gel, turn off the power supply. Separate the gel plates with the help of a spatula or similar tool. Remove the stacking gel.
2. Excise the gel with recombinant proteins such that there is one lane with the protein markers and one with the recombinant proteins.
3. Gently lay one nitrocellulose membrane, cut to the shape of the gel, on top of the gel (*see Note 6*).
4. Gently lift the gel–membrane sandwich from the glass plate and place it on a Whatman no. 3 filter (place membrane side directly on the filter paper and the exposed gel side on top) cut to the size of the gel.
5. Place a second Whatman no. 3 filter paper cut similarly (*see Note 6*).
6. Place the nitrocellulose–gel–filter paper sandwich between two mini-PROTEAN® 3 system running modules with transfer buffer.
7. Place this assembly in a Mini Trans-Blot and run at 37 °C for 60 min at 200 V. Remove the membrane for immunoblotting.

3.7 Western Blot Analysis

1. The molecular mass of the recombinant proteins expressed in *E. coli* is assessed by Western blot using anti-His antibody.
2. Purified recombinant proteins are separated by 12 % SDS–PAGE (*see Note 4*), electrotransferred into a nitrocellulose membrane, and blocked with 5 % nonfat dry milk in PBS at 37 °C for 2 h. After washing with PBST, the membrane is incubated with mouse peroxidase-conjugated monoclonal anti-6× His IgG.

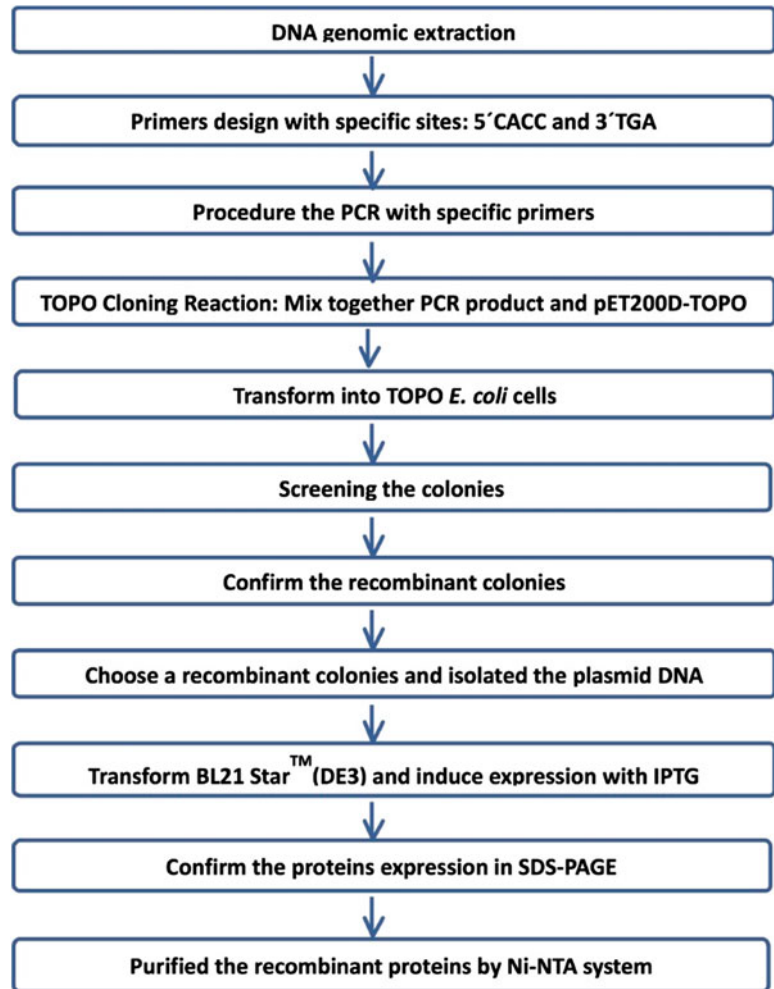

Fig. 2 Step-by-step recombinant protein vaccine production

3. Immunoreactive protein bands are detected with 0.005 % (w/v) 4-chloro-1-naphthol and 0.015 % (v/v) hydrogen peroxidase in PBS (0.005 % (w/v) of 4-chloro-1-naphthol in 10 ml Tris-HCl 50 mM pH 7.5). Add 10 μ l H₂O₂ just before adding to the membrane.
4. Figure 2 shows step-by-step procedure for the generation of recombinant protein vaccines.

3.8 Vaccine Formulation

1. BCA™ Protein Assay kit is used to measure the recombinant protein concentrations according to the instructions provided by the manufacturer.
2. Recombinant proteins are used in a concentration ranging between 20 and 50 μ g in 15 % aluminum hydroxide or similar adjuvants.

4 Notes

1. Set up electroporator Genepulser II (Bio-Rad, USA) for bacterial transformation following the manufacturer's instructions. Add 1–2 μl of each ligation reaction to the volume of cells recommended by the manufacturer (may be less than 50 μl). Mix gently with pipette tip. Do not mix by pipetting up and down. Transfer the cells to the chilled electroporation cuvette (0.1 or 0.2 cm) on ice. Electroporate the cells as per the manufacturer's recommended protocol. Quickly add 250 μl room temperature LB medium and mix gently. Transfer the solution to a 15 ml snap-cap tube (i.e., Falcon) and shake for at least 1 h at 37 °C to allow expression of the antibiotic resistance gene. Spread 10–150 μl from each transformation on a pre-warmed LB plate containing kanamycin (100 $\mu\text{g}/\text{ml}$). The remaining transformation mix may be stored at 4 °C and plated out the next day, if desired. Incubate the plates overnight at 37 °C. Select colonies and lyse the cells for plasmid isolation.
2. Identification and selection of colonies on the plate. To the Eppendorf tube, add 15 μl of phenol–chloroform solution and 15 μl of lysis buffer. Add one identified colony to this tube, shake and centrifuge at 14,000 $\times g$ for 4 min. Apply the upper phase (approximately 15 μl) in agarose gel 0.8 %. It is important to use as a control the plasmid DNA from the vector in the gel to differentiate DNA recombinant from not recombinant clones.
3. Assemble each sequencing reaction as follows: template DNA (0.1–0.2 pmol), primer (5 pmol), sequencing reagent premix (8 μl —DYEnamic ET Terminator Cycle Sequencing Kit, GE Healthcare, USA), and water to a total volume of 20 μl . For sequencing with this DYEnamic ET Terminator Cycle Sequencing Kit, a sequencing reagent premix is combined with template DNA and primer and thermally cycled. The reaction products are then precipitated with ethanol to remove unincorporated dye-labeled terminators. Samples are finally dissolved in an appropriate loading solution for separation and detection using the MegaBACE DNA Analysis Systems—MegaBACE 500 (GE Healthcare, USA) sequence instruments.
4. Mix the recombinant protein 4:1 with the sample buffer (10 % w/v SDS; 10 mM dithiothreitol, or beta-mercaptoethanol; 20 % v/v glycerol; 0.2 M Tris–HCl, pH 6.8; 0.05 % w/v bromophenol blue). Heat the samples at 95 °C for 5–10 min. Clamp in your gel and fill both buffer chambers with gel running buffer (25 mM Tris–HCl; 200 mM glycine; 0.1 % w/v SDS) according to the instructions for your specific apparatus. Add the sample into the gel adjusting the volume according to the amount of protein. Be sure to include a lane with molecular weight standards. Electrophorese at 15 mA

until the sample has entered the gel and then continue at 25 mA till the dye front reaches the bottom of the gel. Remove the gel for the power supply and process further. Visualize your proteins using Coomassie Blue or any of the other protein stains.

5. N-lauroylsarcosine (0.2 %) is used to replace 8 M urea for solubilization of insoluble proteins that reaggregated during dialysis. In this case, the inclusion bodies are solubilized in buffer A, containing 0.2 % N-lauroylsarcosine instead of 8 M urea, incubated at 4 °C for 72 h for complete solubilization. Purification and dialysis are performed as described above.
6. Hold the two top corners of the membranes with each hand. Lower the bottom part of the membrane first on the lower part of the gel and gently release the membrane slowly to lay the complete membrane on the gel. This will prevent trapping of bubbles in between the gel and the membrane.

Acknowledgements

This chapter described work supported by Fundação de Amparo a Pesquisa do Estado do Rio Grande do Sul (FAPERGS), Conselho Nacional de Desenvolvimento Científico e Tecnológico (CNPq), Brazil.

References

1. Thacker EL, Minion FC (2010) Mycoplasmosis. In: Zimmerman J (ed) Diseases of swine. Iowa State University Press, Ames, Iowa, USA, pp 779–797
2. Maes D, Segales J, Meyns T et al (2008) Control of *Mycoplasma hyopneumoniae* infections in pigs. *Vet Microbiol* 126:297–309
3. Vicca J, Stakenborg T, Maes D et al (2004) In vitro susceptibilities of *Mycoplasma hyopneumoniae* field isolates. *Antimicrob Agents Chemother* 48:4470–4472
4. Haesebrouck F, Pasmans F, Chiers K et al (2004) Efficacy of vaccines against bacterial diseases in swine: what can we expect? *Vet Microbiol* 100:255–268
5. Rappuoli R (2001) Reverse vaccinology, a genome-based approach to vaccine development. *Vaccine* 19:2688–2691
6. Razin S, Yogev D, Naot Y (1998) Molecular biology and pathogenicity of mycoplasmas. *Microbiol Mol Biol Rev* 62:1094–1156
7. Nuc P, Nuc K (2006) Recombinant protein production in *Escherichia coli*. *Postepy Biochemii* 52:448–456
8. Simionatto S, Marchioro SB, Galli V et al (2009) Efficient site-directed mutagenesis using an overlap extension-PCR method for expressing *Mycoplasma hyopneumoniae* genes in *Escherichia coli*. *J Microbiol Methods* 79:101–105
9. Galli V, Simionatto S, Marchioro SB et al (2012) Immunization of mice with *Mycoplasma hyopneumoniae* antigens P37, P42, P46 and P95 delivered as recombinant subunit or DNA vaccines. *Vaccine* 31:135–140
10. Simionatto S, Marchioro SB, Galli V et al (2012) Immunological characterization of *Mycoplasma hyopneumoniae* recombinant proteins. *Comp Immunol Microb* 35:209–216
11. Chen AY, Fry SR, Forbes-Faulkner J et al (2006) Evaluation of the immunogenicity of the P97R1 adhesin of *Mycoplasma hyopneumoniae* as a mucosal vaccine in mice. *J Med Microbiol* 55:923–929
12. Chen AY, Fry SR, Forbes-Faulkner J et al (2006) Comparative immunogenicity of *M. hyopneumoniae* NrdF encoded in different expression systems delivered orally via attenuated *S. typhimurium* aroA in mice. *Vet Microbiol* 114:252–259

13. Chen JR, Liao CW, Mao SJ et al (2001) A recombinant chimera composed of repeat region RR1 of *Mycoplasma hyopneumoniae* adhesin with *Pseudomonas* exotoxin: in vivo evaluation of specific IgG response in mice and pigs. *Vet Microbiol* 80:347–357
14. Fagan PK, Walker MJ, Chin J et al (2001) Oral immunization of swine with attenuated *Salmonella typhimurium* aroA SL3261 expressing a recombinant antigen of *Mycoplasma hyopneumoniae* (NrdF) primes the immune system for a NrdF specific secretory IgA response in the lungs. *Microb Pathog* 30:101–110
15. Okamba FR, Arella M, Music N et al (2010) Potential use of a recombinant replication-defective adenovirus vector carrying the C-terminal portion of the P97 adhesin protein as a vaccine against *Mycoplasma hyopneumoniae* in swine. *Vaccine* 28:4802–4809
16. Okamba FR, Moreau E, Cheikh Saad BK et al (2007) Immune responses induced by replication-defective adenovirus expressing the C-terminal portion of the *Mycoplasma hyopneumoniae* P97 adhesin. *Clin Vaccine Immunol* 14:767–774
17. Shimoji Y, Oishi E, Muneta Y et al (2003) Vaccine efficacy of the attenuated *Erysipelothrix rhusiopathiae* YS-19 expressing a recombinant protein of *Mycoplasma hyopneumoniae* P97 adhesin against mycoplasmal pneumonia of swine. *Vaccine* 21:532–537
18. Zou HY, Liu XJ, Ma FY et al (2011) Attenuated *Actinobacillus pleuropneumoniae* as a bacterial vector for expression of *Mycoplasma hyopneumoniae* P36 gene. *J Gene Med* 13:221–229
19. Conceicao FR, Moreira AN, Dellagostin OA (2006) A recombinant chimera composed of RI repeat region of *Mycoplasma hyopneumoniae* P97 adhesin with *Escherichia coli* heat-labile enterotoxin B subunit elicits immune response in mice. *Vaccine* 24:5734–5743
20. Marchioro SB, Sácristan Rdel P, Michiels A et al (2014) Immune responses of a chimaeric protein vaccine containing *Mycoplasma hyopneumoniae* antigens and LT6 against experimental *M. hyopneumoniae* infection in pigs. *Vaccine* 32:4689–4694
21. Chen AY, Fry SR, Daggard GE et al (2008) Evaluation of immune response to recombinant potential protective antigens of *Mycoplasma hyopneumoniae* delivered as cocktail DNA and/or recombinant protein vaccines in mice. *Vaccine* 26:4372–4378
22. Galli V, Simionatto S, Marchioro SB et al (2013) Recombinant secreted antigens from *Mycoplasma hyopneumoniae* delivered as a cocktail vaccine enhance the immune response of mice. *Clin Vaccine Immunol* 20:1370–1376
23. Pinto PM, Chemale G, de Castro LA et al (2007) Proteomic survey of the pathogenic *Mycoplasma hyopneumoniae* strain 7448 and identification of novel post-translationally modified and antigenic proteins. *Vet Microbiol* 121:83–93
24. Sambrook J, Russell DW (2001) *Molecular cloning: a laboratory manual*. Cold Spring Harbor Laboratory Press, New York

Computational Prediction of Immunodominant Epitopes on Outer Membrane Protein (Omp) H of *Pasteurella multocida* Toward Designing of a Peptide Vaccine

Bhaskar Ganguly

1 Introduction

The first step in contemporary vaccine development is the identification of those aspects of an infective organism that can evoke a safe, non-life-threatening immune response without causing a state of disease [1]. This step often follows a protracted course in the wet lab and can prove exceedingly labor and resource intensive. Computational immunology is evolving in its abilities to distinguish the immunogenic components of a pathogen, and the naïve tools of this science offer sufficient speed and cost effectiveness, making computational studies increasingly important in the overall vaccine development process [2]. However, the tools of computational immunology, naïve, as they have been already stated to be, cannot afford enough reliability. A compromising solution to this problem lies in the simultaneous use of several good-performing methods [3] and to abide with the consensus. Many approaches entailing weighted matrices and decision algorithms have been described that render the consensus quantitative; however, such approaches leave little space for an extremely important input in vaccinology—intuition. The prediction approach must not overlook the “underdog” immunogen, which just might fare better in the biological *milieu*. It can be safely stated at this point that sensitivity must find greater priority over specificity while making the computational predictions.

Most vaccines target the humoral immune response that relies on the Class II pathway for processing of the exogenous antigen [1]. Figure 1 presents an oversimplistic view of the processes involved during this response. The current state of the art allows the outcomes of only three of these processes to be predicted com-

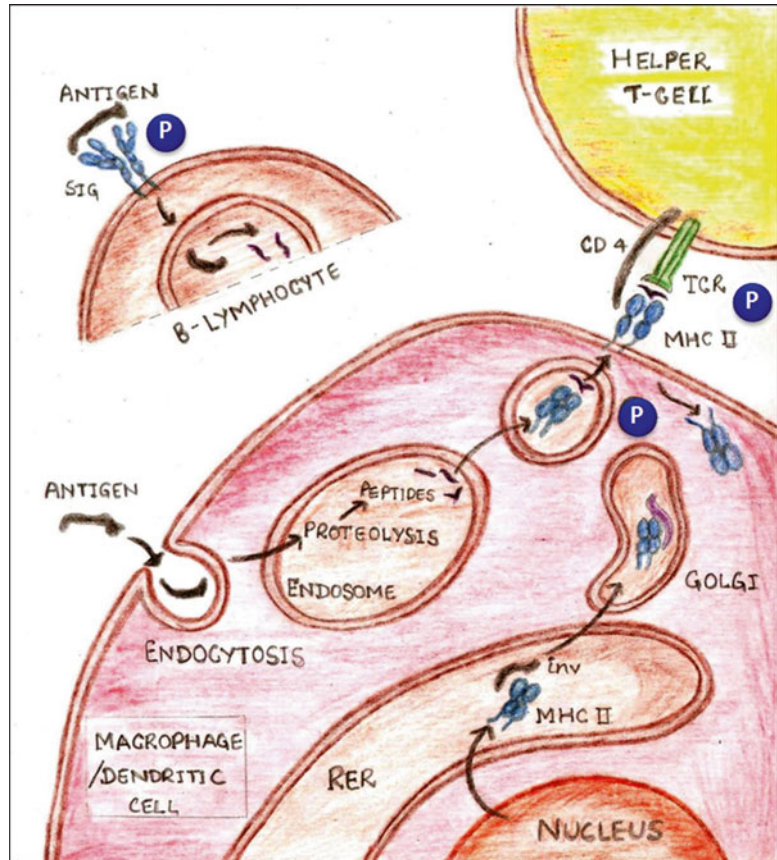

Fig. 1 Humoral immune response depends on Class II pathway for processing of the exogenous antigen. "Ps" have been used to identify the steps that can be predicted computationally (artwork courtesy Ms. Vandana Sharma)

putationally with varying confidence, namely, B-cell antigenicity, MHC-II binding, and T_h -cell antigenicity. While many servers are available for the computational identification of these processes in humans, the corresponding number for animals is scant. *P. multocida* is a major scourge in livestock, especially in the tropics, where it causes recurring epidemics of hemorrhagic septicemia in cattle. It also primarily causes enzootic pneumonia in ruminants, fowl cholera in poultry, atrophic rhinitis in pigs, snuffles in rabbits, and meningitis and appendicitis in humans. As an opportunistic pathogen, it causes secondary diseases including bronchitis, pneumonia, wound infections, cellulitis, osteomyelitis, and appendicial abscesses [4]. Outer membrane protein (Omp) H, variably known as protein H or major outer membrane protein, is a conserved protein in the envelope of *P. multocida* that has been targeted by some workers as a protective antigen [5]. In the sections to follow, we attempt to computationally identify the immunodominant B-cell epitopes on outer membrane protein (Omp) H of *Pasteurella multocida* toward designing of a peptide vaccine for livestock.

2 Materials

2.1 Sequences of OmpH of *P. multocida*

Amino acid sequences of OmpH of *P. multocida* can be obtained from any of the protein databases, the NCBI Protein database, for example (*see Note 1*).

2.2 MEGA

The latest version of MEGA [6] can be downloaded for free from <http://www.megasoftware.net>. For system requirements, installation instructions, and troubleshooting, please refer to the software documentation provided at the website.

2.3 BioEdit Sequence Alignment Editor

BioEdit sequence alignment editor can be downloaded for free from <http://www.mbio.ncsu.edu/bioedit/bioedit.html>. Newer versions of BioEdit have not been available since November, 2013. However, the available version (*v* 7.2.5) works very satisfactorily for the requisite purposes.

2.4 EditSeq and PROTEAN

EditSeq and PROTEAN are proprietary software from DNASTAR. A limited period trial version of this is available for free at <https://www.dnastar.com/t-editseq.aspx> and <https://www.dnastar.com/t-protean.aspx>, respectively. Users interested in regular application may prefer to have the commercially licensed versions (*see Note 2*).

2.5 BepiPred

BepiPred is one of the best-performing linear B-cell epitope prediction methods [7] available for free at <http://www.immuneepitope.org>.

2.6 ElliPro Web Server

The ElliPro web server [8], for identification of conformational B-cell epitopes, can be accessed at <http://tools.immuneepitope.org/tools/ElliPro>. A large number of other web servers that can be used for identification of conformational epitopes are also available.

3 Methods

3.1 Building a Multiple Sequence Alignment

Open the FASTA file containing OmpH sequences with MEGA and select all sequences in the alignment explorer. Select Alignment >>Align by ClustalW to run a multiple sequence alignment (MSA) with default parameters. Once the alignment is completed, click the tab “Data” and export the alignment as a new FASTA (.fasta/ .fas) file. Exit MEGA.

3.2 Analyzing the MSA

Start BioEdit sequence alignment editor. Select all sequences (Edit >>Select all sequences) and view the alignment entropy (Alignment >>Entropy Hx Plot; *see Notes 3 and 4*). Select Alignment >>Find Conserved Regions. Allow two exceptions in maximum entropy

per position. Let all other parameters at their default values and start. This will yield a text file containing the conserved regions. Save the file (*see* **Note 5**). Generate a consensus sequence based on the MSA (Alignment >>Create Consensus Sequence) and save it as a text file (*see* **Notes 6 and 7**). Exit BioEdit.

3.3 Identifying Immunodominant Epitopes and Agretopes

To result in an optimum humoral response, the peptide should not only bear B-cell epitopes but also T-helper cell agretopes within or flanking the B-cell epitopes. Further, the peptide should also be capable of binding MHC-II. These properties can be predicted on the basis of certain structural motifs and biochemical propensities. However, since none of these methods is absolutely reliable, as stated earlier, these must be applied in consensus.

Start EditSeq, select File >>New >>New Protein. Copy and paste the consensus OmpH sequence. Save as a Protein (.PRO) file. Exit EditSeq. Start PROTEAN and open the Protein (.PRO) file containing the consensus OmpH sequence. To apply a particular method, drag and drop the name of the method in to the active window. Use Hopp-Woods and Kyte-Doolittle hydrophilic regions' plots, Eisenberg hydrophobicity plot, Karplus-Schulz flexible regions' plot, and Emini surface regions plot for prediction of linear B-cell epitopes. Similarly, use Chou-Fasman alpha regions, Eisenberg alpha amphipathic regions, AMPHI alpha-helix plot, AMPHI regions, and Rothbard-Taylor T-cell motif methods for T_h-cell agretope prediction. Sette MHC motif should be used for the prediction of MHC-II binding regions. Save the results as a Protean (.pad) file. Exit PROTEAN.

Using the consensus sequence of OmpH as an input, predict the linear B-cell epitopes using BepiPred and the conformational B-cell epitopes using ElliPro (*see* **Note 8**). Once all the methods have been completed, look for linear B-cell epitopes that contain or that are flanked by T_h-cell agretopes and MHC-II binding regions (*see* **Note 9**) within the conserved regions of OmpH. Involvement of these linear epitopes in the formation of conformational epitopes suggests a good potential for inclusion in the peptide vaccine. To reiterate, for qualifying as an immunodominant region for inclusion in the peptide vaccine, the region must have all of the following properties:

- It must lie within a conserved region of the MSA.
- It must have a linear B-cell antigenic nature, as evident from the consensus of the prediction methods.
- It must bear at least one T_h-cell agretope and MHC-II binding region within or abounding it.
- The predicted linear B-cell epitopic residues should participate in the formation of conformational B-cell epitopes.

4 Notes

1. It is important that as many sequences as possible are selected. However, incomplete sequences that are lesser than half of the complete sequence may not be selected if a large number of complete/near-complete sequences are already available. Short, incomplete sequences are only likely to add entropy to the multiple sequence alignment at the next step. All sequences should be saved as a single FASTA (.fasta/.fas) file.
2. PROTEAN bundles several epitope prediction utilities in a single package and deriving the consensus prediction is easier; however, most of these utilities can also be accessed individually on different web servers. BioEdit also serves few of these utilities.
3. Sequences that yield alignments with high entropy are not likely to be good vaccine candidates. High entropy shows that the different sequences (antigens) vary from each other considerably. Hence, antibodies against one antigen will not recognize a different antigen.
4. Within alignments of low entropy, the regions corresponding to very low entropy are those of interest for the purpose of peptide vaccine design. Since these regions are conserved across antigens, antibodies to such peptides will provide protection against pathogens from different sources. Moreover, the highly conserved nature of these regions is, in most cases, suggestive of some essential function—these regions are not likely to mutate under a positive selection pressure and binding of antibodies to these regions renders the essential function disabled.
5. Though not actually a part of the stated problem, it is worthwhile to check the conserved sequences for homologues in the host proteome before proceeding any further. This is easily done by running a BLASTp search with the conserved sequences as inputs and restricting the search to hosts for which the vaccine is intended. Many pathogens harbor proteins that are homologous to one or many of the host proteins; immunization with such peptides may result either in a poor antibody response or self-reacting antibodies.
6. The consensus sequence will almost always contain several gaps. These must be manually filled based on the most common amino acid residue at that particular position in the MSA. This process is tedious and may appear burdensome, but it must be exercised with utmost care.
7. Corresponding to some gaps in the consensus sequence, more than one amino acid may appear with nearly equal frequencies in the MSA. These gaps may be filled with any of these amino acids; however, the biochemical characteristics of the amino

acids should be given due importance. For example, if at a particular position in the MSA, arginine (R), lysine (K), and methionine (M) appear with near-equal frequencies, then the gap in the consensus sequence should be filled with either R or K but not M.

8. Only about 10 % of all B-cell epitopes are linear; the rest are conformational. ElliPro determines the occurrence of amino acid residues within these conformational epitopes based on homology with existing antigen-antibody complexes. The input can be provided in the form of single letter amino acid sequence of the protein or as a structural coordinate file in the .pdb format. For most antigens, the single letter amino acid code is sufficient, but sometimes, ElliPro may not determine homology to existing antigen-antibody complexes. In such events, input of the antigen in the form of structural coordinates, i.e., .pdb format, may be preferred. Determination of 3D structures of proteins is beyond the scope of this discussion. However, it may suffice to state that automated protein structure prediction with good web servers is available for free and generally satisfies the purpose.
9. For the preliminary screening stage, the approach outlined above should generally suffice. If, however, *in vivo* testing shows poor results, heteroclitic modifications in the peptides should be made computationally. Molecular docking studies with the peptide and host-specific MHC-II should be performed and following molecular dynamics, the free energy changes during the binding of the native peptide and the modified peptide should be compared. These applications are beyond the scope of the stated problem. However, the Schrödinger suite is a personal favorite of the author in the face of such applications.

Acknowledgements

The financial assistance received by the author in the form of a Senior Research Fellowship from Council of Scientific and Industrial Research (CSIR), India is gratefully acknowledged. Access to commercial versions of EditSeq and PROTEAN extended by Dr. M.K. Saxena, Assistant Professor, Animal Biotechnology, C.V.A.Sc., G.B.P.U.A. & T., is acknowledged. Preparation of the artwork for Fig. 1 by Ms. Vandana Sharma, fourth year undergraduate student, B.V.Sc. & A.H. program, C.V.A.Sc., G.B.P.U.A. & T., is thankfully acknowledged.

References

1. Flower DR (2008) Bioinformatics for vaccinology. John Wiley and Sons, Ltd. Chichester, UK. 292 p
2. Tong JC, Ren EC (2009) Immunoinformatics: current trends and future directions. *Drug Discov Today* 14:684–689
3. El-Manzalawy Y, Hanovar V (2014) Building classifier ensembles for B-cell epitope prediction. In: De RK, Tomar N (eds) *Immunoinformatics*. *Methods Mol Biol* 1184:285–294
4. Ananthnarayanan R, Jayaram Panicker CK (1996) Textbook of microbiology. Orient Longman, Hyderabad, India, pp 298–305
5. Tewari K (2010) Expression and purification of *OmpH* gene product of *Pasteurella multocida* and protective study of recombinant and native outer membrane proteins, M.V.Sc. Thesis, G.B. Pant University of Agriculture and Technology, Pantnagar, India
6. Kumar S, Nei M, Dudley J, Tamura K (2008) MEGA: a biologist-centric software for evolutionary analysis of DNA and protein sequences. *Brief Bioinform* 9:299–306
7. Larsen JE, Lund O, Nielsen M (2006) Improved method for predicting linear B-cell epitopes. *Immunome Res* 24:2
8. Ponomarenko JV, Bui H, Li W, Fusseder N, Bourne PE, Sette A, Peters B (2008) ElliPro: a new structure-based tool for the prediction of antibody epitopes. *BMC Bioinformatics* 9:514

DNA Vaccines Against Maedi–Visna Virus

Ana M. Henriques, Miguel Fevereiro, and Gabriel A. Monteiro

1 Introduction

Maedi–visna virus (MVV) is a retrovirus of the genus *Lentivirus*, responsible for a slowly progressive disease in sheep, characterized by a relatively long asymptomatic period in which virus persists in the presence of strong humoral and cellular responses [1]. The virus derives its Icelandic name from the symptoms of the disease it causes in sheep. Maedi (dyspnea) is used to describe a slow progressive interstitial pneumonia, while visna (wasting) is a condition resulting from a slow progressive inflammatory disease of the central nervous system, which causes paralysis. The 9.2 kb genome of MVV has three major genes, gag, pol, and env, which encode the virus structural proteins. The core proteins p16, p25, and p14 are encoded by the gag gene, while pol encodes the virus polymerase, and env encodes the envelope glycoproteins gp41 (TM) and gp135 (SU) [2–4]. With the exception of Australia and New Zealand, MVV is spread all over the world. The high levels of infection triggered the application of eradication and control measures in several countries. Cutlip et al. developed an inactivated virus vaccine against MVV; however they were found to be ineffective as the antibodies generated did not protect the animals from infection [5]. Also attenuated MVV vaccines readily stimulated the production of precipitating antibodies in sheep; however they were not able to prevent MVV infection [6]. Since the conventional vaccines have not proven effective in protecting sheep against MVV, DNA vaccines may constitute an alternative approach. This technology has shown to be effective against infection by other members of the *Lentivirus* genus, including FIV [7], CAEV [8], SIV [9], and HIV [10, 11]. DNA vaccines represent a new form of vaccination, where instead of being administered directly, the antigen of interest is encoded in a vector [12]. After administration, the DNA is internalized by the host cells,

wherein the *in vivo* transcription of the gene of interest occurs followed by the synthesis of the protein encoded by the DNA vaccine [13]. The protein is processed and the resulting peptides are presented on the cell surface by MHC I molecules, triggering a cellular response. Moreover, the protein produced in the cell may be secreted and is then internalized by an antigen-presenting cell (APC). Once inside the APC, the protein is processed and presented by MHC II molecules, which elicit a humoral response. Among the main advantages of this type of vaccine are the development of both cellular and humoral immune responses, the production of antibodies against the native form of the protein, the absence of any infection risk and low cost, associated with ease of development, production, storage, and transportation [14].

A possible drawback of this vaccination technology is related with the weak immune response generated. In order to enhance the immunity of DNA vaccines, targeting sequences may be added to the DNA vector to direct the antigenic protein to specific cell compartments where it may be more easily recognized by antigen-presenting cells and therefore will elicit an enhanced immune response. The secretion signal, composed of the first 21 amino acids of the tissue plasminogen activator (tPA) signal, constitutes one of the targeting sequences that can be used to improve DNA vaccination. The targeting of the antigen to the extracellular medium increases its exposition to APCs, which is a desirable property, since the most likely pathway for antigen presentation involves uptake of the DNA vaccine by a cell (non-APC), followed by expression and transmission of the antigen to APCs for presentation [15]. The encoded immunogen expressed in the transfected cells should be taken up by the APCs so as to enter the MHC II antigen-processing and presentation pathways, which conventionally operate only in APCs [16]. Henriques et al. showed that a DNA vaccine against MVV including the Sc-targeting sequence could elicit a stronger humoral response than that induced by the MVV protein alone [2]. Also LAMP (lysosome-associated membrane protein), which directs the antigen to the lysosome where it is proteolytically degraded, can be used as targeting sequence [17]. The resulting peptides are then transported by MHC class II molecules to the cell surface where they are presented to T-helper cells. The targeting of antigens to the lysosome will promote the degradation of proteins synthesized within the cell and activate the MHC II pathway, leading to an increase of both humoral and cellular responses [16, 18]. Another sequence frequently used is E1A, which directs the antigen synthesized to the endoplasmic reticulum (ER). The ER promotes the association of the antigen with MHC I molecules favoring the MHC I pathway and a subsequent cellular response. Furthermore, the MHC II pathway and a subsequent humoral response can be promoted since the ER is also responsible for the trafficking of MHC II molecules through the Golgi to the endocytic route [19].

Another possible drawback of DNA vaccination is the low levels of protein expression, often due to the low efficiency with which DNA enters the cells. This can be circumvented by the use of alternative delivery methods for the transport of the vaccine, such as cationic liposomes that not only assist DNA into penetrating the cell but also prevent its degradation by cellular endonucleases [20]. Cationic liposomes are also stimulators of innate immunity. This approach was successfully used in the development of a DNA vaccine against MVV, since significantly higher transfection efficiencies and humoral responses were obtained *in vitro* and *in vivo*, respectively, when lipoplexes were used [21].

A heterologous prime-boost immunization with DNA and protein has proven useful in most cases [22]. This strategy has the potential for inducing a stronger immune response, probably because boosting with a formulation containing only the relevant epitope in common with the prime immunization may allow preferential expansion of preexisting memory T cells to the epitope of interest [23].

This chapter describes the engineering of DNA vaccines in order to encode for the MVV p16 (matrix protein) and p25 (capsid protein). These proteins were selected since they are core proteins, therefore less likely to mutate. Targeting sequences Sc and LAMP will be also included to enhance the immune response. The experimental designs described in this chapter include the following steps in Subheadings 1.1–1.3.

1.1 Design of the DNA Vaccines

The DNA vaccines are constructed by cloning MVV p16 and p25 encoding genes under the control of a eukaryotic promoter such as the human cytomegalovirus (HCMV). Also an efficient transcription termination/polyadenylation (polyA) signal sequence is necessary to promote gene expression in vaccine recipients [24]. Other essential elements of the plasmid backbone are a prokaryotic origin, an antibiotic selection marker for kanamycin, for example, a multiple cloning site (MCS) and immunostimulatory sequences such as CpG motifs. Plasmids are engineered by directional cloning, using two restriction enzymes that generate cohesive ends. Double digestions with different enzymes allow the generation of compatible cohesive ends for cloning of the genes in the correct orientation. The targeting sequences Sc and LAMP are cloned by the same procedure. All constructs are made to create Kozak sequences flanking the AUG codon sequences, an important feature for recognition by eukaryotic ribosomes. The green fluorescent protein (GFP) reporter gene when fused to the antigenic protein gene allows the assessment of its expression and cellular localization.

1.2 In Vitro Studies

Chinese hamster ovary (CHO) cell line and several ovine primary cells can be used to test plasmids and their biological activity and integrity. Protein expression is analyzed in terms of GFP reporter gene

expression, measured by flow cytometry, a semiquantitative analysis, essential to verify if the plasmids are correctly constructed for expression of the MVV-recombined protein with and without the targeting sequences. The transfection efficiency and mean fluorescence levels of cultured cells are analyzed. These studies are also useful to check for differences among the MVV-GFP fusion proteins containing targeting sequences, which should be directed for processing in different compartments.

1.3 In Vivo Studies

In vivo experiments are performed to focus on the evaluation of the antibody response in mice in order to check the efficiency of the plasmids as DNA vaccines, after vaccination with MVV DNA prototype vaccines. A heterologous prime-boost strategy is used. The humoral response in mice vaccinated with the different constructs is measured by enzyme-linked immunosorbent assay (ELISA) in sera collected regularly during the in vivo assays.

2 Materials

2.1 Design of the DNA Vaccines

2.1.1 Cloning of the MVV p16 and p25 Encoding Sequences

1. Genomic DNA of PIOLV MVV Portuguese isolate [25] obtained from lung cells (*see Note 1*).
2. Forward and reverse primers (*see Table 1*).
3. Taq DNA polymerase and respective reaction buffer.
4. Deoxynucleotide mixture (10 mM of dATP, dCTP, dGTP, dTTP).
5. MgSO₄ 25 mM.
6. Agarose.
7. TBE 1×: 89 mM Tris base, 89 mM Boric acid, 2 mM EDTA.
8. Ethidium bromide 0.5 mg/ml.

Table 1
Primers used in the amplification of p16 and p25 MVV encoding genes

Primer	Sequence	Amplicon length	Annealing (°C)	Extension (s)
Nhe-p16-F	GCGCGCTAGCATGGCGAAGCAA GGCTCAAAGGAG	451 bp	50	90
Afl-p16-R	GCGCCTTAAGCCGTAGACCTCC TTATGTGTCTC			
Nhe-p25-F	GCGCGCTAGCATGGCCATAGTAAAT TTACAAGCAG	694 bp	52	120
Afl-p25-R	GATACTTAAGCCCAATTGCATTTTAA ATCCTTCTG			

Restriction sites are underlined and the start codon is in bold

9. Loading buffer 6×: 60 mM Tris–HCl pH 8.6, 100 mM NaCl, 2 mM β -mercaptoethanol.
10. DNA molecular weight marker.
11. UV protection mask.
12. Scalpel tip.
13. Transilluminator.
14. Gel extraction kit such as QIAquick Gel Extraction Kit (QIAGEN).
15. Preheated sterilized MilliQ water at 65 °C.
16. Spectrophotometer.
17. Plasmid pVAX-GFP (*see Note 2*).
18. Restriction enzymes NheI and AflII and respective buffer.
19. T4 DNA ligase and respective buffer.
20. *E. coli* DH5 α cells.
21. TSS buffer: 10 ml LB 2×, 1 ml MgCl₂ 1 M, 2 g PEG 8000, 1 ml DMSO, in a final volume of 20 ml.
22. Luria–Bertani (LB) broth medium: yeast extract 5 g/l, sodium chloride 10 g/l, tryptone 10 g/l).
23. LB agar: tryptone 10 g/l, yeast extract 5 g/l, NaCl 5 g/l, agar 15 g/l.
24. Kanamycin 50 mg/ml, 0.2 μ m filtered.
25. Water bath.
26. Orbital incubator 37 °C.
27. Plasmid purification kit such as High Pure Plasmid Isolation kit (Roche).
28. Cryovials.
29. Glycerol for molecular biology (99 %).
30. Plasmid midi purification kit such as Plasmid Purification Midi (QIAGEN).
31. Isopropanol 100 % (v/v).
32. Ethanol 70 % (v/v).
33. Phosphate-buffered saline (PBS): 0.9 % NaCl, 10 mM sodium phosphate, pH 7.2.

2.1.2 Cloning of the Sc-
and LAMP-Targeting
Sequences

1. Sc and LAMP forward and reverse synthetic oligonucleotides (*see Table 2*).
2. Taq DNA polymerase and respective reaction buffer.
3. Deoxynucleotide mixture (10 mM of dATP, dCTP, dGTP, dTTP).
4. Plasmids VAX-p16 and VAX-p25.

Table 2
Sequence of synthetic oligonucleotides used to introduce the targeting sequences

Sequence	
Sc	Forward: GGG <u>GGT</u> GACCATGGACGCCATGAAGCGCGGCCTGTGCTGCGTGCTGC TGCTGTG Reverse: CCC <u>GCTAG</u> CGCGGGCGCTCACGAACACGGCGCCGCACAGCAGCAGCAC GCAGCAC
LAMP	Forward: GGG <u>CTCG</u> AGTCTTGAACAACATGTTGATCCCCATTGCTGTGGGGCGGT GCCCTGGCAGGGCTGGT <u>CCTCATCGT</u> CCTCATTGCCTACC Reverse: CCC <u>GGGCCCT</u> CTAGATGGTCTGATAGCCGGCGTGACTCCTCT TCCTGCCAATGAGGTAGGCAATGAGGACGATGAGGAC

Restriction sites are underlined and the regions complementary in the two oligonucleotides are shown in bold

5. Restriction enzymes BstEII, NheI, XhoI and DraII, and respective buffers.
6. Agarose.
7. TBE 1×: 89 mM Tris base, 89 mM Boric acid, 2 mM EDTA.
8. Ethidium bromide 0.5 mg/ml.
9. Loading buffer.
10. DNA molecular weight marker.
11. UV protection mask.
12. Scalpel tip.
13. Transilluminator.
14. Gel extraction kit such as QIAquick Gel Extraction Kit (QIAGEN).
15. Preheated sterilized MilliQ water at 65 °C.
16. Spectrophotometer.
17. T4 DNA ligase and respective buffer.
18. *E. coli* DH5α cells.
19. TSS buffer (10 ml LB 2×, 1 ml MgCl₂ 1 M, 2 g PEG 8000, 1 ml DMSO, in a final volume of 20 ml).
20. Luria–Bertani (LB) broth medium: yeast extract 5 g/l; sodium chloride 10 g/l; tryptone 10 g/l.
21. LB agar: tryptone 10 g/l; yeast extract 5 g/l; NaCl 5 g/l; agar 15 g/l.
22. Kanamycin 50 mg/ml, 0.2 μm filtered.
23. Water bath.
24. Orbital incubator 37 °C.
25. Plasmid mini purification kit such as High Pure Plasmid Isolation kit (Roche).

26. Cryovials.
27. Glycerol for molecular biology (99 %).
28. Plasmid midi purification kit such as Plasmid Purification Midi (QIAGEN).
29. Isopropanol 100 % (v/v).
30. Ethanol 70 % (v/v).
31. Phosphate-buffered saline (PBS): 0.9 % NaCl, 10 mM sodium phosphate, pH 7.2.

2.2 In Vitro Assays

1. 75 cm² T flasks.
2. F12 (HAM) culture medium (Invitrogen): 22.5 ml of F12 (HAM) nutrient mixture 1×, 1 % of antibiotic-antimycotic 100×, 1 % of modified Eagle medium-nonessential amino acids (MEM-NEAA) 100×, 1 % of 100 mM sodium pyruvate, 0.1 % of gentamicin (50 mg/ml), 1.5 ml of inactivated fetal bovine serum (FBS).
3. One vial of CHO cells (with approximately 4× 10⁶ cells) resuspended in 1 ml of FBS with 10 % DMSO.
4. DMEM culture medium (Invitrogen): 22.5 ml of DMEM nutrient mixture 1×, 1 % of antibiotic-antimycotic 100×, 1 % of modified Eagle medium-nonessential amino acids (MEM-NEAA) 100×, 1 % of 100 mM sodium pyruvate, 0.1 % of gentamicin (50 mg/ml), 1.5 ml of inactivated fetal bovine serum (FBS).
5. One vial of SCP (sheep choroid plexus), OSM (ovine synovial membrane), TO (sheep testicle), and OSk (ovine skin) cells (with approximately 4× 10⁶ cells) resuspended in 1 ml of FBS with 10 % DMSO.
6. Incubator at 37 °C and 5 % of CO₂-humidified environment.
7. 50-ml conical centrifuge tubes.
8. Lipofectamine™ 2000 (Invitrogen).
9. Candidate DNA vaccines.
10. Incomplete F12 (HAM) medium (without antibiotics).
11. Incomplete DMEM medium (without antibiotics).
12. Trypsin-Versene solution: 8 g/l NaCl, 0.4 g/l KCl, 1 g/l glucose, 0.58 g/l NaHCO₃, 0.5 g trypsin (1:250), 0.2 g/l EDTA, pH 7.2–7.4.
13. Sterile 24-well plates.
14. Sterilized PBS: 0.9 % NaCl, 10 mM sodium phosphate, pH 7.2.
15. Paraformaldehyde (PFA) 2 % (w/v).
16. 15-ml conical centrifuge tubes.
17. 5-ml polystyrene round-bottom tubes and aluminum foil to protect samples from light.

2.3 *In Vivo Assays*

1. Candidate DNA vaccines.
2. MVV-purified virus 0.45 µg/µl.
3. Octyl-2 % in PBS.
4. Six- to eight-week-old female BALB/c mice.
5. Microneedles (27G×1/2", 0.4×12 mm, 1 ml).
6. 96-well ELISA plates.
7. ELISA plate washing machine.
8. Pool of mouse sera.
9. 3D9 MVV monoclonal antibody.
10. Carbonate–bicarbonate buffer: 15 mM Na₂CO₃, 35 mM NaHCO₃, pH 9.6.
11. Washing buffer: H₂O/Tween 0.05 %.
12. Serum dilution buffer: 2.5 mM NaH₂PO₄, 7.5 mM Na₂HPO₄, 500 mM NaCl, 0.05 % Tween 80.
13. Horseradish peroxidase-conjugated rabbit anti-mouse immunoglobulin.
14. Fetal ovine serum.
15. Peroxidase substrate: 10 mg OPD (o-Phenylenediamine dihydrochloride) in 25 ml citrate/phosphate buffer (35 mM citric acid, 67 mM Na₂HPO₄) with 10 µl de H₂O₂.
16. Stop solution: H₂SO₄ 10 %.
17. Absorbance microplate reader.

3 Methods

3.1 *Design of the DNA Vaccines*

3.1.1 *Cloning of the MVV p16 and p25 Encoding Sequences in pVAX-GFP*

1. Amplify the p16 and p25 encoding genes by PCR, using primers indicated in Table 1 (*see Notes 3–5*).
2. Use 500 ng genomic DNA (*see Note 1*), 100 pmol of each primer, 5 U Taq DNA polymerase, 400 µM dNTPs, 10 µl buffer reaction 10×, and 4 µl MgSO₄ 25 mM in a final volume of 100 µl.
3. Put the reactions in a thermocycler under the following amplification program: initial denaturation at 94 °C for 2 min, followed by 35 cycles of 30 s denaturation at 94 °C, 30 s annealing at variable temperature (*see Table 1*) and extension at 72 °C for variable time (*see Table 1*). The program ends with a final extension period of 10 min at 72 °C.
4. Check the size of the expected fragments (*see Table 1*) by agarose gel electrophoresis.
5. Set up a 1 % agarose gel by adding 0.5 g of agarose to 50 ml TBE 1×.

6. Melt the agarose, add 2.5 μl ethidium bromide, transfer the mixture to a tray, and allow the gel to polymerize for 30 min (*see Note 6*).
7. Place the tray with the gel inside the electrophoresis chamber and apply the PCR product with 5 μl of sixfold loading buffer. In one well apply 5 μl of the molecular weight marker.
8. Run the 1 % agarose gel electrophoresis at 120 V for 45 min.
9. After electrophoresis, remove the gel from the electrophoresis chamber, put it under UV light, and check for the presence of the desired bands.
10. Excise the band corresponding to the amplicon.
11. Purify the DNA from the agarose gel slices with an appropriate commercial kit such as QIAquick Gel Extraction Kit (QIAGEN) following the manufacturer's instructions.
12. Measure the concentration of the amplified fragment at 260 nm (*see Note 7*).
13. Double digest the amplicon and the vector pVAX-GFP (*see Note 2*) with NheI and XhoI restriction enzymes (*see Note 8*), using 1 μl of NheI (10 U/ μl), 0.5 μl of XhoI (20 U/ μl), tenfold enzyme buffer, MilliQ sterilized water, and 3 μg of plasmid DNA or 5 μg amplified fragment.
14. Incubate the mixture for 2 h at 37 °C.
15. Purify the restricted fragments and vector with an appropriate commercial kit such as QIAquick Gel Extraction Kit (QIAGEN) following the manufacturer's instructions (*see Note 9*).
16. Measure the concentration of the amplified fragment and the vector at 260 nm (*see Note 7*).
17. Perform a ligation mixture with 1 U of T4 DNA ligase and 4 μl of fivefold T4 ligase buffer, for a final volume of 20 μl , considering the mass of insert and vector needed for the reaction (*see Note 10*).
18. Incubate the mixture for 3 h at room temperature.
19. Transform 50 μl of competent *E. coli* DH5 α cells (*see Note 11*) with 10 μl of ligation mixture.
20. Incubate the cells with the 10 μl of the ligation mixture for 30 min on ice.
21. Heat the mixture for 30 s at 42 °C and subsequently cool it on ice for 2 min.
22. Add immediately 250 μl of sterile liquid LB medium, and incubate the cells at 37 °C with agitation for 1 h.
23. Plate in LB agar supplemented with 50 mg/ml kanamycin.
24. Incubate overnight at 37 °C.

25. After incubation, recombinants can be observed. To confirm the presence of the expected clones, pick and inoculate several colonies in 5 ml of LB medium with kanamycin at 37 °C, overnight with agitation.
26. Purify the plasmids with a commercial kit such as High Pure Plasmid Isolation kit (Roche), following the manufacturer's instructions.
27. To check for the presence of fragments of interest, double digest 1 µg plasmid DNA for 1 h at 37 °C with 10 U of NheI and AflII in the corresponding buffer.
28. Run the mixtures in 1 % agarose gel in order to confirm the correct size of the fragments.
29. Prepare cell banks of the correct clones as follows. Inoculate one single colony in 5 ml of LB medium with 5 µl of kanamycin (50 µg/ml) overnight at 37 °C and 250 rpm in an orbital shaker. Distribute 160 µl of culture into cryovials containing 40 µl of glycerol, mix well, and store at -80 °C.
30. Prepare high amounts of plasmids VAX-p16 and VAX-p25, using a plasmid midi purification kit such as Plasmid Purification Midi (QIAGEN), according to the manufacturer's instructions from 200 ml of LB medium supplemented with kanamycin.

3.1.2 Cloning of the Sc and LAMP Targeting Sequences

1. Double digest Sc targeting sequence (*see Note 12*) with BstEII and NheI and the LAMP signal (*see Note 12*) with XhoI and DraII restriction enzymes, as indicated in **step 13** of Subheading **3.1.1**, for 2 h at 37 °C.
2. Double digest plasmids VAX-16 and VAX-p25 with the same enzymes (BstEII/NheI and XhoI/DraII each), as indicated in **step 13** of Subheading **3.1.1**, for 2 h at 37 °C.
3. Separate the restricted fragments in an agarose gel as indicated in Subheading **3.1.1**, **steps 5–9**.
4. Excise the bands corresponding to cleaved plasmids and targeting sequences.
5. Purify the DNA from the agarose gel slices with an appropriate commercial kit such as QIAquick Gel Extraction Kit (QIAGEN) following the manufacturer's instructions.
6. Measure the concentration of the fragments at 260 nm (*see Note 7*).
7. Perform a ligation mixture with 1 U of T4 DNA ligase and 4 µl of the fivefold T4 ligase buffer, for a final volume of 20 µl, considering the mass of sequence and plasmid needed for the reaction (*see Note 10*).
8. Incubate the mixture for 3 h at room temperature.
9. Transform 50 µl of competent *E. coli* DH5α cells (*see Note 11*) as indicated in **steps 19–24** of Subheading **3.1.1** with 10 µl of ligation mixture.

10. Pick and inoculate several colonies in 5 ml of LB medium with kanamycin at 37 °C, overnight with agitation and purify the plasmids with a commercial kit such as High Pure Plasmid Isolation kit (Roche), following the manufacturer's instructions.
11. To check for the presence of fragments of interest, double digest 1 µg of plasmid DNA for 1 h at 37 °C with 10 U of BstEII and NheI for Sc and XhoI and DraII for LAMP, in the corresponding buffer.
12. Run the mixtures in 1 % agarose gel in order to confirm the correct size of the fragments.
13. Prepare cell banks of the correct clones as indicated in **step 29** of Subheading 3.1.1.
14. Prepare high amounts of plasmids Sc-p16, Sc-p25, p16-LAMP, and p25-LAMP, using a plasmid midi purification kit such as Plasmid Purification Midi (QIAGEN), according to the manufacturer's instructions from 200 ml of LB medium supplemented with kanamycin.

3.2 *In Vitro Assays*

3.2.1 *Culture*

and Transfection of Cells

1. Grow a starting culture of CHO (Chinese hamster ovary) cells by adding one vial of frozen cells to a 75 cm² T flask with 22.5 ml of supplemented F12 (HAM) nutrient mixture and 1.5 ml of inactivated FBS. Grow starting cultures of SCP (sheep choroid plexus), OSM (ovine synovial membrane), TO (sheep testicle), and OSk (ovine skin) cells by adding one vial of frozen cells to a 75 cm² T flask with 22.5 ml of supplemented DMEM nutrient mixture and 1.5 ml of inactivated FBS.
2. Incubate the T flasks at 37 °C in a 5 % of CO₂-humidified environment up to a confluence of 80–90 %.
3. Discard the culture medium from each T flask and perform a quick wash of the cells with 8 ml of PBS.
4. Trypsinize the cells with 8 ml of trypsin for 5–10 min at 37 °C.
5. Transfer cells on the trypsin solution to 50-ml conical centrifuge tubes and centrifuge at 230 × *g* for 10 min.
6. Discard the supernatants and resuspend the pellets in 5 ml of PBS.
7. Perform 1:10 dilutions in PBS. Take a sample from the diluted solutions and count the cells in a Neubauer chamber.
8. Make appropriate dilutions in order to have a final volume of 500 µl containing 2 × 10⁵ cells per well. Consider three wells per each plasmid and three wells for the negative control (cells without plasmid).
9. Centrifuge at 230 × *g* for 10 min.
10. Resuspend the pellets in a mixture containing 450 µl medium without antibiotics and 50 µl of inactivated FBS per well and distribute 500 µl of the mixture per well of a 24-well plate.

11. Incubate the plates at 37 °C in a 5 % of CO₂-humidified environment for 24 h in order to reach a confluence of 80–90 %.
12. For each well prepare separately one mixture containing 2 µl of Lipofectamine and 48 µl of incomplete medium and one mixture containing 1 µg of plasmid DNA and incomplete medium up to a final volume of 50 µl. For the negative controls, prepare a mixture of 2 µl Lipofectamine and 98 µl of incomplete medium. Consider performing triplicates for both plasmid DNAs and negative controls.
13. Prepare a transfection mixture with a final volume of 100 µl by mixing the two solutions and incubate at room temperature for 20 min.
14. Discard 250 µl of medium from each well.
15. Add 100 µl of the transfection mixture to each well in the plate. Add 100 µl of the plasmid-free transfection mixture to each of the negative control wells.
16. Incubate the 24-well plates at 37 °C in a 5 % of CO₂-humidified environment for 4–6 h.
17. Remove the medium and transfection mixture from each well and add fresh complete medium with antibiotics and 10 % FBS up to a final volume of 500 µl per well.
18. Incubate cells for 48 h at 37 °C in a 5 % of CO₂-humidified environment.

3.2.2 Analysis of Protein Expression by Flow Cytometry

1. Harvest transfected cells after 48 h of incubation.
2. Discard the complete medium and wash each well with 800 µl of sterilized PBS.
3. Add 200 µl of trypsin to each well, and incubate the plates for 5 min at 37 °C.
4. Centrifuge the cells from each well in 15-ml conical centrifuge tubes.
5. Add 1 ml of PBS to each well in order to recover cell leftovers and transfer to the corresponding centrifuge tube.
6. Centrifuge at 230×g for 10 min.
7. Discard the supernatant, and resuspend the resulting pellets in 800 µl of 2 % PFA, fixing cells and allowing flow cytometry analysis to be postponed.
8. Cover the tubes with aluminum foil and keep at 4 °C until flow cytometry analysis.
9. Analyze the green fluorescence intensity corresponding to GFP expression level and determine the transfection efficiency and the mean fluorescence, using appropriate software (*see Note 13*).

3.3 In Vivo Assays

3.3.1 Immunization of Mice

1. Divide the 6–8 weeks female BALB/c mice in groups of five animals. Prepare seven groups of mice for testing VAX-p16, VAX-p25, Sc-p16, Sc-p25, p16-LAMP, and p25-LAMP. The negative control group receives pVAX without insert.
2. Immunize mice subcutaneously or intramuscularly with 50 µg of each DNA vaccine prototypes in 100 µl of PBS.
3. Perform two boost immunizations at 3 weeks interval.
4. Perform a heterologous boost 3 weeks after the last DNA administration. Since MVV does not infect mice, 5 mg of purified MVV (*see Note 14*) is administered as protein boost. Inoculate also the negative control group of mice with purified virus.
5. Regularly bleed up mice by facial venipuncture.
6. Centrifuge the blood at $2000 \times g$ for 5 min and collect the serum fraction.
7. Prepare pools of sera from each group by adding the same volume of each mice serum. Store all samples at -20°C .

3.3.2 Evaluation of Humoral Response

1. Coat a 96-well ELISA plate with 50 µl MVV-purified virus (*see Note 14*) diluted 1:500 in carbonate-bicarbonate buffer after pretreatment (1:1) with 2 % octyl for 15 min at 4°C in order to prevent clump formation.
2. Incubate the ELISA plate overnight at 4°C .
3. Wash the plate four times with washing solution.
4. Prepare four serial dilutions of serum samples from 1:100 to 1:800 in serum dilution buffer and transfer of each dilution to the coated plate. To one well add 50 µl 3D9 MVV monoclonal antibody as positive control.
5. Incubate the ELISA plate at 37°C for 1 h.
6. Wash the plate four times with washing solution.
7. Add 50 µl horseradish peroxidase-conjugated rabbit anti-mouse immunoglobulin diluted 1:1000 in serum dilution buffer with 5 % fetal ovine serum.
8. Incubate the plate at room temperature for 1 h and then wash four times with washing solution.
9. Add 50 µl OPD solution (10 mg OPD tablet dissolved in 25 ml citrate/phosphate buffer with H_2O_2).
10. Incubate for 1 h in the dark, at room temperature.
11. Stop the reaction by adding 50 µl of 10 % sulfuric acid.
12. Measure the absorbance at 492 nm in a microplate reader.

4 Notes

1. As a retrovirus, MVV is an RNA virus. After the retroviral genome enters the host cell, the enzyme reverse transcriptase catalyzes the synthesis of a DNA strand using the viral RNA chain as template. The same enzyme catalyzes the synthesis of a second DNA strand complementary to the first, yielding a double-stranded DNA fragment. The resulting double-stranded DNA can then be integrated into the chromosomal double-stranded DNA of the host cell, a process that occurs through the integrase enzyme activity. For that reason, the amplification of MVV encoding genes can be performed by RT-PCR through genomic RNA or by PCR from DNA integrated in the host cell. For being less expensive and easier to perform, the later approach must be adopted, and therefore the template for amplification can be obtained by genomic DNA extraction using a commercial kit such as Wizard DNA Genomic Purification kit (Promega), according to the manufacturer's instructions.
2. pVAX-GFP may be used as vector. This plasmid is derived from pVAX1lacZ (Invitrogen), in which the lacZ reporter gene was replaced by the eGFP gene, cloned between the XbaI and EcoRI restriction sites by Azzoni et al. [26].
3. This technique allows exponential amplification of a DNA sequence using two primers that delimit the region to be amplified. This amplification is usually carried out by a high temperature-resistant polymerase extracted from the bacterium *Thermus aquaticus* (Taq polymerase). The primers hybridize to each of the template DNA strands serving as initiators for the polymerization reaction, which takes place from both the 5' ends by the addition of nucleotides by Taq polymerase enzyme. The reaction is subjected to a series of cycles, about 35, comprising denaturation (94–95 °C), annealing of primers (depending of the pair of primers used), and extension (68–72 °C), wherein each formed strand of DNA serves as a template for the synthesis of a new strand. Sometimes, the sequences of the primers are slightly modified in order to facilitate future cloning.
4. Forward primers are designed to contain a small tail of four bases at the 5' end to allow enzymatic digestion, followed by restriction site NheI (GCTAGC). In forward primer used for amplification of sequence encoding the p25 protein, it is necessary to introduce the ATG start codon, since this protein is encoded by a precursor gene, which is then processed to give protein p25. A Kozak sequence (ANNATGG) is known to facilitate the initiation of translation [27–29]. Since the penultimate base of the introduced NheI restriction site is an

adenine, the Kozak sequence is created only by changing the first base after the start codon to a guanine (ATGG).

5. Regarding reverse primers, a small tail of four bases is introduced to facilitate digestion, followed by the restriction site for AflII enzyme (GAATTC) and about 20 bp complementary to the DNA template. In order to put the gene in the same ORF of the GFP encoding gene located downstream, thus allowing the expression of a fusion protein, two additional bases were introduced between the restriction site and the protein-encoding gene.
6. It is advised to mix vigorously and perform microwave heating without boiling, until all agarose is melted. Use a pipette tip to remove bubbles before agarose jellifies in the tray.
7. Perform the calibration of the spectrophotometer using the same solution used to elute the DNA in order to obtain a more reliable concentration value. Make a 1:50 dilution using 2 μ l of sample and 98 μ l of MilliQ water. The Abs 260 nm readings are converted into mass concentrations by the following correlation: 1 U Abs 260 nm = 50 μ g/ml of DNA.
8. The fragments are digested with two different enzymes, NheI which cleaves at the 5' end and AflII which cleaves at the other end. This double digestion aims to force the fragment to be inserted into the vector in the correct direction, i.e., with the initiation codon at the 5' end. The pVAX-GFP vector is digested with the same restriction enzymes, to give cohesive ends compatible with the fragment, allowing the ligation.
9. This purification step is essential to remove enzymes, buffer, and the cleaved fragments to eliminate.
10. The ligation between the fragment and the vector is made through the enzyme T4 DNA ligase, which catalyzes the formation of a phosphodiester bond between the phosphate group of the 5' end of the fragment and the OH group of the 3' end of the vector and vice versa. For the reaction mixture, consider a 3:1 insert/vector molar ratio and a mass of vector of approximately 50 ng. Do the calculations according to the following equation:

$$\text{ng}_{\text{fragment}} = \frac{\text{ng}_{\text{vector}} \times \text{kb}_{\text{fragment}}}{\text{kb}_{\text{vector}}} \times 3$$

11. The competence is previously induced after cell growth to an optical density of 0.4 with 0.1 culture volumes of buffer TSS (10 ml LB 2 \times , 1 ml MgCl₂ 1 M, 2 g PEG 8000, 1 ml DMSO, in a total volume of 20 ml).
12. The sequence used as a secretion signal is the first 21 amino acids of the tissue plasminogen activator (tPA) signal and the

gene encoding this protein is cloned at the 5' end of the sequence encoding the MVV proteins, giving rise to plasmids Sc-p16 and Sc-p25. As a targeting sequence to lysosome, a DNA fragment encoding the transmembrane domain of 24 amino acids and 11-amino acid cytoplasmic tail of LAMP protein is cloned at the 3' end of GFP encoding gene in VAX-p16 and VAX-p25, yielding the plasmids p16-LAMP and p25-LAMP, respectively.

The targeting sequences Sc and LAMP are obtained from two synthetic oligonucleotides, one containing the 5' end of the gene and another containing its 3' end. Both oligonucleotides contain the core region of the gene and thus can hybridize one to another. The forward and reverse synthetic oligonucleotide still had the BstEII/NheI and XhoI/DraII restriction sites, for Sc and LAMP cloning, respectively (*see* Table 2). To complete the sequence in both directions, a PCR reaction is carried using as template the region of DNA oligonucleotides not hybridized. Each reaction is performed with 100 pmol of each primer, 400 μ M each dNTP, 2.5 U of *Taq* DNA polymerase, and respective reaction buffer diluted tenfold in a final volume of 50 μ l. The amplification program consists of an initial denaturation of 2 min at 94 °C, followed by a series of 35 cycles of 30 s denaturation at 94 °C, 30 s annealing at 65 °C, and 2 min extension at 72 °C. A final extension for 7 min at 72 °C is also recommended.

13. Perform flow cytometry up to 4 days after cell harvesting. Always use the same time for each set of experiments. Use the cytometer to record the forward scatter (FSC), side scatter (SSC), and green fluorescence (FL1) in each run. For each sample, the cytometer discriminates cells from the debris due to their characteristics of FSC versus SSC, distinguishing cells from debris that are outside the gate. Background autofluorescence of non-transfected cells is taken into account considering the difference between total cell population inside the gate and the background autofluorescence of non-transfected cells indicated by FL1 parameter. This establishes the M1 and M2 parameters, corresponding to non-transfected and transfected cells with green fluorescence, respectively. Transfection efficiency is defined as the percentage of cells that express fluorescence above a threshold level, defined by autofluorescence of non-transfected cells. Cells transfected with plasmids Sc-p16 and Sc-p25 tend to show less fluorescence than cells transfected with VAX-p16 or VAX-p25, because this protein is likely to be secreted to the extracellular space and therefore is no longer available in the cytoplasm for detection. Low fluorescence values are also anticipated for cells transfected with p16-LAMP or p25-LAMP, because sorting to lysosomes and subsequent degradation are expected. Cells expressing the

non-fused GFP protein are expected to exhibit higher levels of fluorescence due to the expression of GFP molecules instead of a fusion protein.

14. To obtain viral antigen, MVV is grown in SCP cells and the supernatants of cultures showing 80 % cytopathic effect are clarified by centrifugation. The virus is precipitated by the addition of PEG and purified in a discontinuous sucrose gradient as previously described by Fevereiro et al. [30].

References

1. Clements JE, Zink MC (1996) Molecular biology and pathogenesis of animal lentivirus infections. *Clin Microbiol Rev* 9(1):100–117
2. Henriques AM, Fevereiro M, Prazeres DM, Monteiro GA (2007) Development of a candidate DNA vaccine against Maedi-Visna virus. *Vet Immunol Immunopathol* 119:222–232
3. Power C, Richardson S, Briscoe M, Pasick J (1995) Evaluation of two recombinant Maedi-visna virus proteins for use in an enzyme-linked immunosorbent assay for the detection of serum antibodies to ovine lentiviruses. *Clin Diag Lab Immunol* 2:631–633
4. Sonigo P, Alizon M, Staskus K, Klatzmann D, Cole S, Danos O, Retzel E, Tiollais P, Haase A, Wain-Hobson S (1985) Nucleotide sequence of the visna lentivirus: relationship to the AIDS virus. *Cell* 42:369–382
5. Cutlip RC, Lehmkuhl HD, Brogden KA, Schmerr MJ (1987) Failure of experimental vaccines to protect against infection with ovine progressive pneumonia (maedi-visna) virus. *Vet Microbiol* 13:201–204
6. Petursson G, Matthiasdottir S, Svansson V, Andresdottir V, Georgsson G, Martin AH, Agnarsdottir G, Gisladdottir E, Arnadottir S, Hognadottir S, Jonsson SR, Andresson OS, Torsteinsdottir S (2005) Mucosal vaccination with an attenuated maedi-visna virus clone. *Vaccine* 23:3223–3228
7. Hosie MJ, Flynn JN, Rigby MA, Cannon C, Dunsford T, Mackay NA, Argyle D, Willett BJ, Miyazawa T, Onions DE, Jarrett O, Neil JC (1998) DNA vaccination affords significant protection against feline immunodeficiency virus infection without inducing detectable antiviral antibodies. *J Virol* 72:7310–7319
8. Cheevers WP, Snekvik KR, Trujillo JD, Kumpula-McWhirter NM, Pretty On Top KJ, Knowles DP (2003) Prime-boost vaccination with plasmid DNA encoding caprine arthritis encephalitis lentivirus env and viral SU suppresses challenge virus and development of arthritis. *Virology* 306:116–125
9. Hanke T, Samuel RV, Blanchard TJ, Neumann VC, Allen TM, Boyson JE, Sharpe SA, Cook N, Smith GL, Watkins DI, Cranage MP, McMichael AJ (1999) Effective induction of simian immunodeficiency virus-specific cytotoxic T lymphocytes in macaques by using a multiepitope gene and DNA prime-modified vaccinia virus Ankara boost vaccination regimen. *J Virol* 73:7524–7532
10. Vaine M, Wang S, Crooks ET, Jiang P, Montefiori DC, Binley J, Lu S (2008) Improved induction of antibodies against key neutralizing epitopes by human immunodeficiency virus type 1 gp120 DNA prime-protein boost vaccination compared to gp120 protein-only vaccination. *J Virol* 82:7369–7378
11. Muthumani K, Zhang D, Dayes NS, Hwang DS, Calarota SA, Choo AY, Boyer JD, Weiner DB (2003) Novel engineered HIV-1 East African Clade-A gp160 plasmid construct induces strong humoral and cell-mediated immune responses in vivo. *Virology* 314:134–146
12. Krishnan BR (2000) Current status of DNA vaccines in veterinary medicine. *Adv Drug Deliv Rev* 43:3–11
13. Bahloul C, Jacob Y, Tordo N, Perrin P (1998) DNA-based immunization for exploring the enlargement of immunological cross-reactivity against the lyssaviruses. *Vaccine* 16:417–425
14. Khan KH (2013) DNA vaccines: roles against diseases. *Germs* 3:26–35
15. Qiu JT, Liu B, Tian C, Pavlakis GN, Yu XF (2000) Enhancement of primary and secondary cellular immune responses against human immunodeficiency virus type 1 gag by using DNA expression vectors that target Gag antigen to the secretory pathway. *J Virol* 74:5997–6005
16. Ruff AL, Guarneri FG, Staveley-O'Carroll K, Siliciano RF, August JT (1997) The enhanced immune response to the HIV gp160/LAMP chimeric gene product targeted to the lysosome membrane protein trafficking pathway. *J Biol Chem* 272:8671–8678

17. Chikhlikar P, Barros de Arruda L, Agrawal S, Byrne B, Guggino W, August JT, Marques ET Jr (2004) Inverted terminal repeat sequences of adeno-associated virus enhance the antibody and CD8(+) responses to a HIV-1 p55Gag/LAMP DNA vaccine chimera. *Virology* 323:220–232
18. Wu TC, Guarneri FG, Staveley-O'Carroll KF, Viscidi RP, Levitsky HI, Hedrick L, Cho KR, August JT, Pardoll DM (1995) Engineering an intracellular pathway for major histocompatibility complex class II presentation of antigens. *Proc Natl Acad Sci U S A* 92:11671–11675
19. Carvalho JA, Azzoni AR, Prazeres DM, Monteiro GA (2010) Comparative analysis of antigen-targeting sequences used in DNA vaccines. *Mol Biotechnol* 44:204–212
20. Gregoriadis G, Bacon A, Caparros-Wanderley W, McCormack B (2002) A role for liposomes in genetic vaccination. *Vaccine* 20(Suppl 5):B1–B9
21. Henriques AM, Madeira C, Fevereiro M, Prazeres DM, Aires-Barros MR, Monteiro GA (2009) Effect of cationic liposomes/DNA charge ratio on gene expression and antibody response of a candidate DNA vaccine against Maedi Visna virus. *Int J Pharma* 377:92–98
22. Amara RR, Villinger F, Altman JD, Lydy SL, O'Neil SP, Staprans SI, Montefiori DC, Xu Y, Herndon JG, Wyatt LS, Candido MA, Kozyr NL, Earl PL, Smith JM, Ma HL, Grimm BD, Hulsey ML, McClure HM, McNicholl JM, Moss B, Robinson HL (2002) Control of a mucosal challenge and prevention of AIDS by a multiprotein DNA/MVA vaccine. *Vaccine* 20:1949–1955
23. Dunachie SJ, Hill AV (2003) Prime-boost strategies for malaria vaccine development. *J Exp Biol* 206(Pt 21):3771–3779
24. Williams JA, Carnes AE, Hodgson CP (2009) Plasmid DNA vaccine vector design: impact on efficacy, safety and upstream production. *Biotechnol Adv* 27(4):353–370
25. Barros SC, Ramos F, Duarte M, Fagulha T, Cruz B, Fevereiro M (2004) Genomic characterization of a slow/low maedi visna virus. *Virus Genes* 29:199–210
26. Azzoni AR, Ribeiro SC, Monteiro GA, Prazeres DM (2007) The impact of polyadenylation signals on plasmid nuclease-resistance and transgene expression. *J Gene Med* 9:392–402
27. Kozak M (1987) An analysis of 5'-noncoding sequences from 699 vertebrate messenger RNAs. *Nucleic Acids Res* 15(20):8125–8148
28. Kozak M (1990) Downstream secondary structure facilitates recognition of initiator codons by eukaryotic ribosomes. *Proc Natl Acad Sci U S A* 87:8301–8305
29. Kozak M (1991) An analysis of vertebrate mRNA sequences: intimations of translational control. *J Cell Biol* 115:887–903
30. Fevereiro M, Barros S, Fagulha T (1999) Development of a monoclonal antibody blocking-ELISA for detection of antibodies against Maedi-Visna virus. *J Virol Methods* 81:101–108

Detection of Avian Antigen-Specific T Cells Induced by Viral Vaccines

Tina Sørensen Dalgaard, Liselotte Rothmann Norup,
and Helle Risdahl Juul-Madsen

1 Introduction

1.1 Vaccination of Chickens

Poultry is a worldwide important food resource and the production sector continues to grow. Chickens are susceptible to a range of pathogens, some of which are also transmissible to and disease causing in humans, e.g., avian influenza virus. Apart from this, a range of viral diseases is a threat to the animals and causes extensive losses in the chicken production industry.

In a historic perspective, the study of the chicken immune system has contributed to our understanding of fundamental immunological principles as reviewed by [1, 2]. Thus, the chicken bursa of Fabricius provided the first evidence of two major lineages of lymphocytes and also understanding of Ig diversification by gene conversion. The chief understanding of MHC-related disease resistance is also derived from studies in chickens. Notably, the research by Louis Pasteur leading to the first attenuated vaccine comprised fowl cholera infection studies in chickens. Later, the first vaccine against a natural occurring cancer agent, Marek's disease virus, was developed in chickens.

Live attenuated viral vaccines are widely used in commercial poultry production, and evidence that intensive vaccination may lead to increased virulence has been reported for some pathogens, e.g., Marek's disease virus. Indeed, the new viral strains from each successive wave acquired ability to overcome the immunity induced by the previously used vaccine strain [3]. This warns of the need to use more sustainable vaccination strategies that do not drive the pathogen to ever increasing virulence. Thus, it is of interest to develop new effective inactivated/subunit vaccines with capacity to induce long-lasting protecting immunity in commercial chickens.

1.2 Tools for Assessment of Vaccine-Induced CMI

Cell-mediated immunity (CMI) induced by viral vaccines is important for disease protection. For years, the possibilities to measure the specificity and magnitude of CMI in chickens were hampered due to lack of reagents. Tools were restricted to “classical assays” such as proliferation measured by ^3H -thymidine incorporation and CTL activity measured by ^{51}Cr release. These techniques have limitations, e.g., in their suitability for studying MHC-undefined individuals and in their ability to distinguish between different reactive cell subsets. However, rational vaccine design demands establishment of robust T cell assays with the ability to assess phenotype and function of chicken T cell subsets.

Few reports exist on developed chicken tetramers [4, 5] and the reagents are not yet commercially available. Thus, studies of chicken antigen-specific T cells are primarily based on analyses *ex vivo* after activating the cells with recall antigen. There is a particular interest in developing robust high-throughput assays as chicken vaccine trials usually comprise many individuals (of several different MHC haplotypes). Growing numbers of monoclonal antibodies to chicken lymphocyte surface markers and cytokines are now available, which provides new opportunities for addressing chicken CMI in recall assays.

1.3 Ex Vivo Antigen Presentation

Responses to pathogens are similar in birds and mammals; features of innate, adaptive, humoral, and cell-mediated immunity are present in both [2, 6, 7]. But in many respects, details of organs, cell types, and molecules differ between birds and mammals. Just to mention a few, chickens lack lymph nodes and have a different repertoire of immunoglobulins, cytokines/chemokines, and pattern recognition receptors. Moreover, chickens lack neutrophils which are replaced by the apparent functional equivalents, heterophils. Also, a large proportion of circulating T cells (20–50 %) express $\gamma\delta$ T cell receptors (TCR) rather than $\alpha\beta$ TCR. Finally, chickens have nucleated thrombocytes as well as nucleated erythrocytes. Both cell types have been shown to respond to TLR ligands and are therefore suggested to have immunological functions [8, 9].

These differences in the avian immune system result in difficulties in adapting mammalian protocols directly to chicken studies. For the antigen stimulation assays, it is still unclear exactly which cell types are needed in the chicken samples to ensure sufficient MHC presentation of the recall antigen. Notably, density gradient preparations of chicken peripheral blood mononuclear cells (PBMC) differ from human PBMC preparations with respect to at least two cell types. (1) First of all, the samples may contain a significant amount of nucleated thrombocytes. Chicken thrombocytes have been reported as the primary blood phagocyte [10]. They can phagocytose 1.7 times as many bacteria three times as rapidly as heterophils and monocytes, but it is not clear if they may also function as APCs for

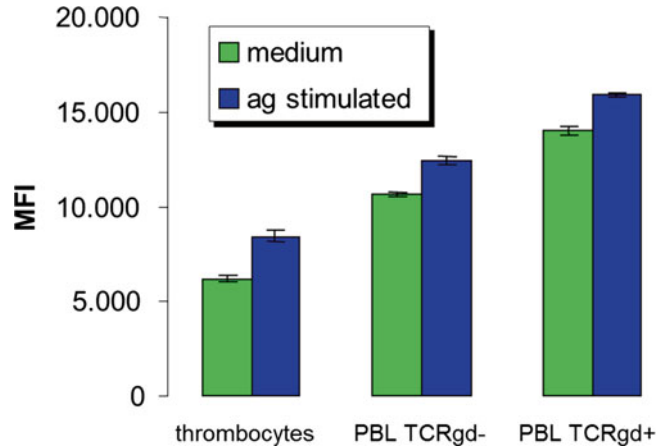

Fig. 1 MHC-I expression on different PMBC subsets. Cells were isolated from a chicken immunized with commercial live Newcastle disease virus (NDV) vaccine. Mean fluorescence intensities (MFI) of MHC class I staining were determined on different PBMC subsets after stimulation with UV-inactivated NDV antigen (Ag) overnight and compared to the expression on cells in medium alone. Standard deviations are indicated between triplicate determinations

induction of T cell responses in the chicken. Interestingly, a significant increase in MHC class I expression was observed on thrombocytes upon recall stimulation (Fig. 1). (2) A large proportion of T cells in a sample may be constituted by $\gamma\delta$ T cells. Their possible involvement in the initiation of chicken adaptive immunity remains unclear, but they are able to professionally take up and present soluble antigen via the classical MHC class II loading pathway and induce CD4⁺ T cell proliferation in humans [11]. Also, the chicken $\gamma\delta$ T cells show significantly increased MHC class I expression upon recall stimulation (Fig. 1). Whether or not the presence of high numbers of chicken $\gamma\delta$ T cells is important for the induction of T cell proliferation in the CFSE assay still remains to be elucidated, but the $\gamma\delta$ cells do certainly respond vigorously to specific antigen and proliferation and IFN- γ production is easily induced in this T cell subset [12]. Therefore, it is crucial for robust chicken T cell assays to distinguish between different cellular subsets. For this purpose, simultaneous phenotypic and functional studies at single-cell level, e.g., by flow cytometry, remain the optimal choice.

1.4 Readouts after Recall Activation

The lymphocyte activation can be evaluated by different methods using functional readouts such as proliferation, expression of surface activation markers, or cytokine production [13]. Apart from the popular ELISPOT technique (which provides information on the frequency of responding cells but not their phenotype), only few reports exist on studies of avian antigen-specific T cells at single-cell level.

The very informative intracellular cytokine staining (ICS) technique that allows visualization of single cells and their cytokine production, frequency, and phenotype has been used extensively in human medical research [14, 15]. The method is not yet widely used in avian immunology research, but two reports describe the ICS method used to study IFN- γ production in splenic T cell subsets [16, 17].

The carboxyfluorescein succinimidyl ester (CFSE) test described in this chapter has been adapted to chicken cells and has so far been the most frequently published flow cytometric technique used to study chicken antigen-specific T cells [12, 18–20]. In this test, cells are loaded with CFSE by passive diffusion of the chemical into the cytoplasm where intracellular esterases cleave its acetate groups yielding a highly fluorescent product. The succinimidyl ester group covalently binds to cellular amines forming fluorescent conjugates that are retained in the cells even throughout division. This leads to daughter cells containing half the fluorescence of their parents. When lymphocytes are loaded with CFSE prior to *ex vivo* stimulation, the measurement of serial halving of its fluorescence by flow cytometry identifies the cells responding to the stimulation.

2 Materials

2.1 CFSE Staining of PBMC and Activation by Specific Antigen/Mitogen

1. Peripheral blood mononuclear cells (PBMC) prepared by Ficoll-Paque PLUS (GE Healthcare) density gradient centrifugation (*see Note 1*).
2. Phosphate-buffered saline (PBS).
3. Culture medium, e.g., RPMI-1640 (Lonza), supplemented with heat-inactivated fetal calf serum (FCS) (*see Note 2*).
4. Specific protein/peptides for antigen stimulation (*see Note 3*).
5. Concanavalin A (ConA) (Sigma) for positive stimulation control. Prepare stock solution in PBS and use 5–10 $\mu\text{g}/\text{ml}$ as final concentration in stimulated cell cultures (*see Note 4*).
6. CellTrace™ CFSE Cell Proliferation Kit (Molecular Probes).
7. Penicillin–Streptomycin (Gibco).
8. 15-ml sterile conical polypropylene centrifugation tubes.
9. 96-well culture plates (Nunc) (Nunc).
10. CO₂ incubator (5 %) at 41 °C.

2.2 Surface Staining of Phenotypic Markers before Flow Cytometry

1. Ethylenediaminetetraacetate (EDTA) in sterile PBS—final concentration 2 mM for cell detachment.
2. Anti-chicken antibodies directed against, e.g., CD3, CD4, and CD8, conjugated to suitable fluorochromes (*see Note 5*).
3. Staining/washing buffer (FACS buffer), e.g., PBS supplemented with 0.2 % BSA, 0.2 % azide, and 0.05 % horse serum.

2.3 Flow Cytometry and Data Analysis

1. Suitable flow cytometer.
2. Data analysis software, e.g., BD FACSDiva or FlowJo.

3 Methods

PBMC must be isolated by Ficoll density gradient centrifugation from blood sampled from vaccinated/immune chickens under sterile conditions (*see Note 6*). For the recall stimulation culture in 96-well plates, $1\text{--}2 \times 10^6$ cells are used per well in a final concentration of 1×10^7 cells/ml. As cells may be lost during the washing steps in the CFSE staining protocol, it is recommended to stain at least twice as many PBMC as desired for the subsequent culture in the presence of antigen/mitogen.

3.1 CFSE Staining of PBMC

1. After gradient centrifugation, transfer the interphase and the supernatant above it to a new centrifugation tube.
2. Wash twice with PBS.
3. Resuspend in PBS, count the cells using a hemocytometer.
4. In a separate tube, prepare a $0.5 \mu\text{M}$ CFSE solution (e.g., add $1 \mu\text{l}$ CFSE [5 mM stock in DMSO] to 10 ml of PBS) (*see Note 7*).
5. Pellet the desired number of PBMC and next discard all PBS.
6. Thoroughly resuspend cells in the $0.5 \mu\text{M}$ CFSE solution at a concentration of 1×10^7 cells/ml.
7. Wrap the tube in foil, mix/vortex gently, and place it in a water bath at $25\text{--}37^\circ\text{C}$ (*see Note 8*) for 10 min . (Vortex gently again after 5 min as it is important to stain cells as uniformly as possible).
8. Wash cells twice with large volumes of RPMI, e.g., stain 2×10^7 cells in a 15-ml tube and use $6\text{--}10 \text{ ml}$ RPMI for each wash.
9. Resuspend cells in RPMI supplemented with FCS (5%), penicillin (100 U/ml), and streptomycin (100 mg/ml). Adjust cell concentration to $1\text{--}2 \times 10^7/\text{ml}$ and add $50\text{--}100 \mu\text{l}$ to each well in a cell culture plate. (Remember to fill some additional wells with unstained PBMC to be used for flow cytometry compensation).

3.2 Culture with Recall Antigen

1. Add recall antigen or mitogen in $50\text{--}100 \mu\text{l}$ RPMI supplemented with FCS (5%), penicillin (100 U/ml), and streptomycin (100 mg/ml). The optimal concentration of recall antigen/antigenic peptides must be determined by titration (*see Note 9*). The optimal final concentration of the positive control ConA is usually $5\text{--}10 \mu\text{g/ml}$.
2. As negative control, add $50\text{--}100 \mu\text{l}$ RPMI supplemented with FCS (5%), penicillin (100 U/ml), and streptomycin (100 mg/ml) without mitogen or antigen to each well (*see Note 10*).

3. Incubate the cells for 3–5 days in a CO₂ incubator (5 %) at 41 °C (*see Note 11*).
4. If subsequent staining for phenotypic markers will not be performed, e.g., in a screening/optimization setup, cells can be analyzed directly by flow cytometry at this step.

3.3 Staining for Phenotypic Markers before Flow Cytometry

1. At day 5 add 20 mM EDTA to all wells to a final concentration of 2 mM (*see Note 12*).
2. Leave the plate for 5 min on a gentle plate shaker followed by 10 min in the CO₂ incubator.
3. Mix well by pipetting and pellet the cells by centrifugation at 300 × *g* for 5 min.
5. Add fluorochrome-conjugated antibodies directed against surface CD or activation markers in 100 µl FACS buffer and mix gently by pipetting.
4. Incubate the plate for 15 min in the dark at 4 °C.
5. Wash the cells two times with FACS buffer using centrifugation at 300 × *g* between each wash.
6. Resuspend cells in FACS buffer or PBS.

3.4 Flow Cytometry

1. Fluorescence parameters should be acquired with logarithmic amplification. The PMT voltages for surface phenotypic and activation markers should be set, so the negative population is in the first decade (lowest) of the logarithmic scale. The PMT for CFSE detection should be set so that un-proliferated cells (negative control) are in the top decade of the logarithmic scale.
2. Forward scatter and side scatter should be acquired with linear amplification and allow gating to exclude debris and dead cells (*see Note 13*).
3. Gating strategy should comprise exclusion of dead cells by viability dye staining. In some cases (e.g., if erythrocyte contamination), it is convenient to gate on singlet cells bearing in mind that this doublet exclusion would also exclude dividing cells in late mitotic phases.
4. Results can be shown directly by frequency of proliferating cells (corrected for background proliferation). Additional data analysis can be performed using software such as ModFit to calculate precursor frequencies.

4 Notes

1. Preferably, use heparin-stabilized blood. However, EDTA-stabilized blood can be used if cells are carefully washed in Dulbecco's PBS, and culture is performed in medium supplemented with chicken serum to ensure optimal calcium

restoration [20]. The assay can also be performed using single-cell suspensions from lymphoid tissue, e.g., spleen.

2. RPMI supplemented with 5–10 % FCS is useful for short-term cultures (2–3 days). However, for longer-term cultures (4–6 days), we found that substituting RPMI/FCS with a serum-free medium (e.g., X-VIVO™15, Lonza) reduced background proliferation in the negative controls significantly [12].
3. The use of synthetic immunogenic peptides as recall antigen for chicken T cells has been reported by others [17, 21, 22]. Alternatively, UV-inactivated commercial vaccine virus can be used directly [12], but in order to avoid contaminating compounds from the vaccine production process, it may be useful to purify the virus antigen on sucrose gradient [23].
4. Higher ConA concentrations than 10 µg/ml can be used for short-term cultures, but this will compromise viability in long-term cultures.
5. It is important to include a viability dye in the staining panel as it is usually not possible to exclude all dead cells by FSC/SSC gating. Furthermore, CFSE shows significant spillover in the PE detector of many instruments. Resolution sensitivity will be lost by compensation, and the PE detector should only be used to study brightly expressed surface phenotyping antigens. When phenotyping circulating chicken CD8⁺ cells, it is important to distinguish between TCR usage of the cells. CD8⁺ γδ T cells are abundant in many individuals, and they proliferate vigorously in response to stimulation with specific antigens [12]. Furthermore, the chicken CD8α gene is polymorphic and different isoforms of the molecule exist. When testing three different clones of CD8α antibodies on PBMC from inbred white leghorn chickens (AU lines/Tjele, [24]), we observed different specificities of the antibodies—only the Clone 3–298 appeared to recognize all CD8α isoforms present in the tested chicken lines [20].
6. As an alternative to Ficoll gradient isolation of PBMC, slow-speed centrifugation of PBS-diluted blood (350×g for 10 min) can be used. In our hands, mitogen-induced proliferation is lower in PBMC isolated by Ficoll gradient centrifugation as compared with PBMC isolated by slow-speed centrifugation, which has also been reported by others [25]. However, we found that PBMC isolated by Ficoll gradient centrifugation contained monocytes, whereas PBMC prepared by slow centrifugation were almost devoid of monocytes (Fig. 2). This confirms the findings of Schaefer et al. [26], who reported that monocytes were the suppressive element of impaired mitogenic responses in Ficoll samples. Clearly, ex vivo mitogen and antigen-specific activation involve different cellular mechanisms, and we observed no inhibition of antigen-specific proliferation in Ficoll-isolated PBMC (Fig. 3). In the current recall assay, the responding T cells rely on antigen-presenting cells (e.g., B cells and monocytes) present

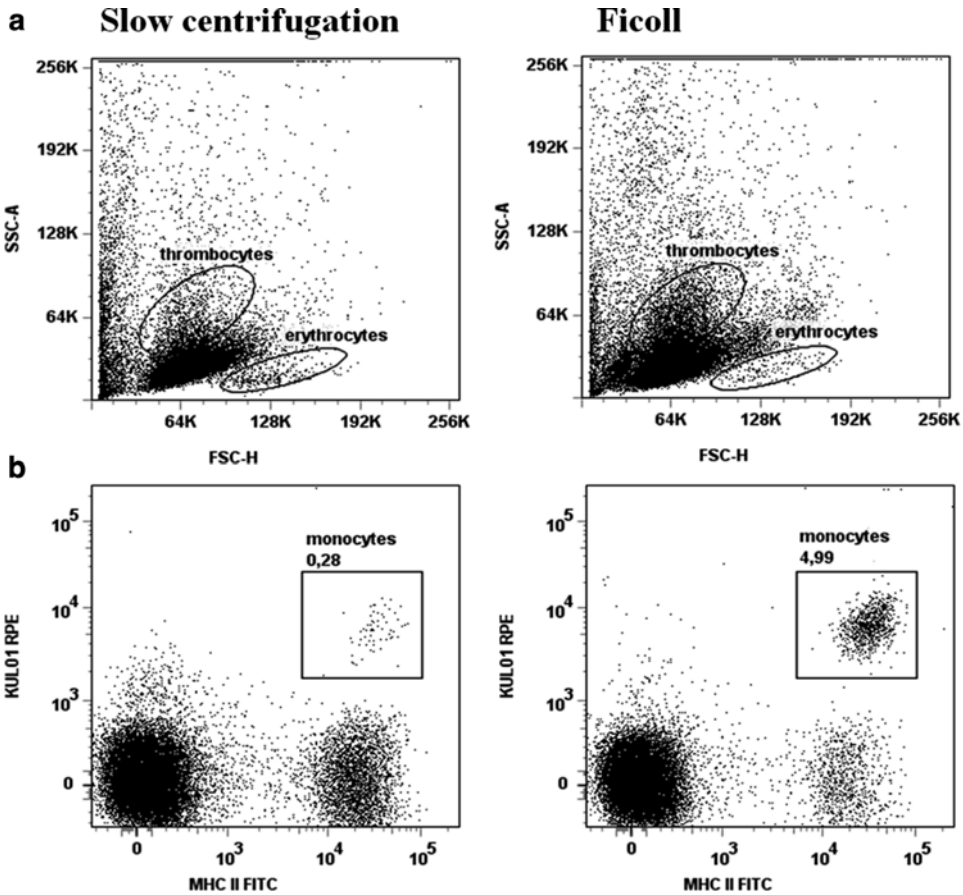

Fig. 2 Flow cytometric comparison of chicken PBMC isolated by Ficoll gradient or by slow-speed centrifugation. **(a)** Thrombocytes and erythrocytes were identified by their FCS/SSC characteristics in the two different PBMC preparations. **(b)** Monocytes were identified as being KUL-01 and MHC class II positive. Monocyte frequencies in the different PBMC preparations were identified and results from one representative individual are shown

within the sample. As Ficoll gradient centrifugation leads to a higher frequency of monocytes that are potentially important for proper MHC presentation of recall antigen [27], this method was chosen for preparation of PBMC. Apart from monocytes, thrombocytes are also present in higher numbers in Ficoll samples as compared to slow spin samples [28].

7. The optimal CFSE concentration must be determined by titration to ensure bright staining throughout the experiment. For long-term culture, higher concentrations are usually needed, but this may lead to decreased viability and compensation difficulties. In our hands, 0.5 μ M CFSE proved optimal for chicken PBMC kept 3–6 days in culture.
8. According to the manufacturer, CFSE staining should take place at 37 °C. This works very well for chicken PBMC, however, we find that staining at 25 °C works equally well, but provides slightly better viability of the stained cells.

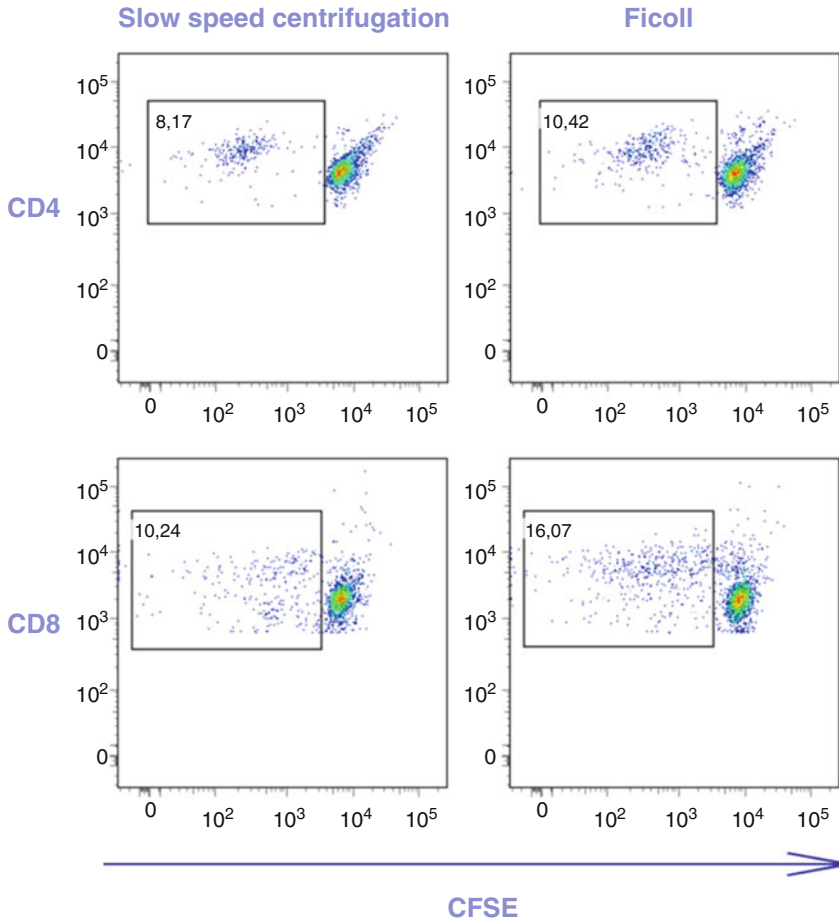

Fig. 3 Comparison of antigen-induced proliferation in PBMC isolated either by Ficoll gradient or slow-speed centrifugation. Cells from one representative chicken immunized with commercial live Newcastle disease virus (NDV) vaccine are shown. Cells were CFSE stained, rested O/N, and subsequently stimulated with UV-inactivated NDV antigen. Cells were analyzed by flow cytometry after another 4 days in culture, and the percentages of proliferated CD4+ and CD8+ cells were recorded

9. Others suggest to let the cells rest at least 5 h after CFSE staining [29]. Indeed, we find that antigen-induced (but not mitogen-induced) proliferative response increases if cells are allowed to rest. For practical reasons, we let them rest overnight in the CO₂ incubator.
10. It is important to keep wells of unstimulated cells for compensation throughout the culture. For proper compensation, wells of both CFSE-stained and non-stained cells are needed. FITC is not the proper compensation control as CFSE has a slightly different emission spectrum. Furthermore, we observe slight differences in CFSE brightness of the stained cells between experiments, and therefore, the current batch of CFSE-stained cells should always be used for compensation.
11. In general, problems with background proliferation increase with the amount of time cells are kept in culture. Obviously,

the frequency of circulating antigen-specific T cells varies between different vaccination/infection models, and the optimal length of incubation should be determined for each experiment. This is not always feasible, but in our hands, O/N rest followed by 4 days of culture in the presence of antigen generally works well for assessment of T cell responses induced by live attenuated viral vaccines in chickens.

12. Activated T cells may display “culture plate stickiness.” As shown in Fig. 4, cell detachment by EDTA prior to flow cytometric analysis resulted in improved detection of the proliferation of

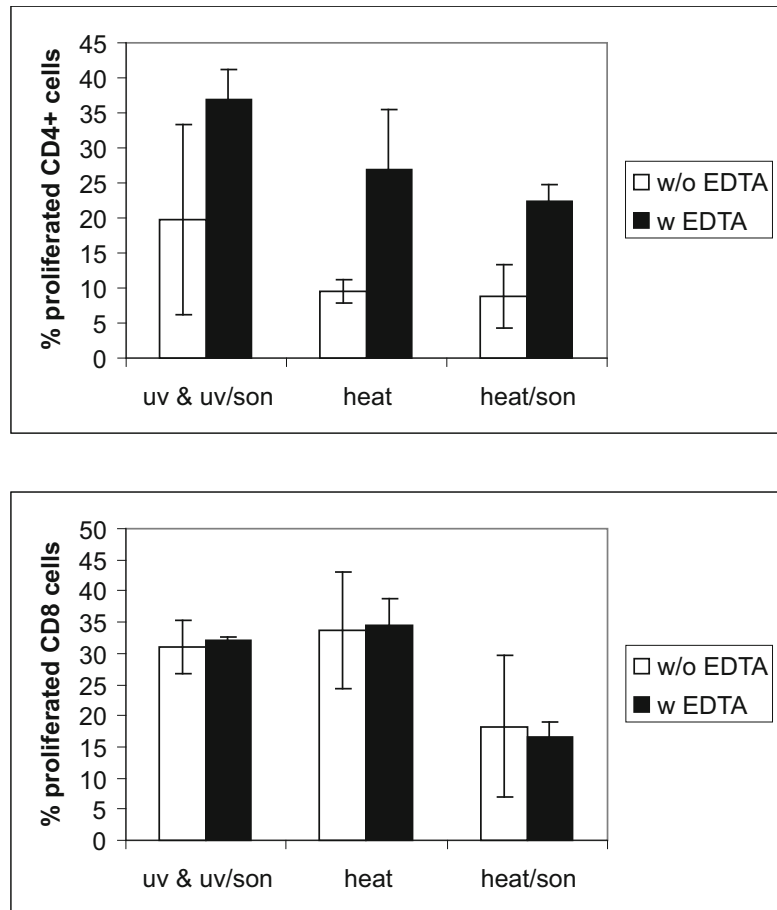

Fig. 4 Effect of EDTA detachment before flow cytometric analysis. Results are shown from one representative chicken immunized with commercial live Newcastle disease virus (NDV) vaccine. PBMC were CFSE stained, rested O/N, and left in culture for another 4 days with different recall antigen preparations. The NDV vaccine antigen was inactivated by either UV light and ultrasound, heat alone, or heat and ultrasound. The frequencies of proliferated CD4+ and CD8+ cells were determined by CFSE dilution with or without EDTA treatment prior to flow cytometric analysis. Standard deviations are indicated between triplicate determinations

CD4+ cells. Furthermore, the EDTA treatment appeared to lower the variation between duplicate measurements (data not shown) in both the CD4 and the CD8 compartment.

13. When gating to exclude debris, it is important not to exclude cells with increased FSC/SSC.

Acknowledgements

This work was supported by grants from the Danish Research Council (274-06-0258), the Danish Poultry Council, and Aarhus University.

References

1. Davison TF (2003) The immunologists' debt to the chicken. *Br Poultry Sci* 44:6–21
2. Kaiser P (2012) The long view: a bright past, a brighter future? Forty years of chicken immunology pre- and post-genome. *Avian Pathol* 41:511–518
3. Witter RL (2001) Marek's disease vaccines – past, present and future – [chicken vs. virus – a battle of the centuries]. The Bart Rispens Memorial Lecture. *Current Progress on Marek's Disease Research* 1–9
4. Liu G, Wang Q, Liu N, Xiao Y, Tong T, Liu S, Wu D (2012) Infectious bronchitis virus nucleoprotein specific CTL response is generated prior to serum IgG. *Vet Immunol Immunopathol* 148:353–358
5. Niemiec PK, Read LR, Sharif S (2006) Synthesis of chicken major histocompatibility complex class II oligomers using a baculovirus expression system. *Protein Expr Purif* 46:390–400
6. Kaiser P (2010) Advances in avian immunology – prospects for disease control: a review. *Avian Pathol* 39:309–324
7. Kaiser P, Wu Z, Rothwell L, Fife M et al (2009) Prospects for understanding immune-endocrine interactions in the chicken. *Gen Comp Endocrinol* 163:83–91
8. St Paul M, Paolucci S, Barjesteh N, Wood RD, Schat KA, Sharif S (2012) Characterization of chicken thrombocyte responses to Toll-like receptor ligands. *PLoS One* 7(8):e43381
9. St Paul M, Paolucci S, Barjesteh N, Wood RD, Sharif S (2013) Chicken erythrocytes respond to Toll-like receptor ligands by up-regulating cytokine transcripts. *Res Vet Sci* 95:87–91
10. Chang CF, Hamilton PB (1979) Thrombocyte as the primary circulating phagocyte in chickens. *J Reticuloendoth Soc* 25:585–590
11. Moser B, Eberl M (2007) $\gamma\delta$ T cells: novel initiators of adaptive immunity. *Immunol Rev* 215:89–102
12. Dalgaard TS, Norup LR, Rubbenstroth D, Watrang E, Juul-Madsen HR (2010) Flow cytometric assessment of antigen-specific proliferation in peripheral chicken T cells by CFSE dilution. *Vet Immunol Immunopathol* 138:85–94
13. Thiel A, Scheffold A, Radbruch A (2004) Antigen-specific cytometry – new tools arrived! *Clin Immunol* 111:155–161
14. Picker LJ, Singh MK, Zdraveski Z, Treer JR et al (1995) Direct demonstration of cytokine synthesis heterogeneity among human memory/effector T cells by flow cytometry. *Blood* 86:1408–1419
15. Suni MA, Picker LJ, Maino VC (1998) Detection of antigen-specific T cell cytokine expression in whole blood by flow cytometry. *J Immunol Methods* 212:89–98
16. Ariaans MP, van de Haar PM, Lowenthal JW, van Eden W et al (2008) ELISPOT and intracellular cytokine staining: novel assays for quantifying T cell responses in the chicken. *Dev Comp Immunol* 32:1398–1404
17. Ruiz-Hernandez R, Peroval M, Boyd A, Balkissoon D et al (2014) An infected chicken kidney cell co-culture ELISpot for enhanced detection of T cell responses to avian influenza and vaccination. *J Immunol Methods* 416:40–48
18. Dalgaard TS, Norup LR, Pedersen AR, Handberg KJ et al (2010) Flow cytometric assessment of chicken T cell-mediated immune responses after Newcastle disease virus vaccination and challenge. *Vaccine* 28:4506–4514
19. Hou Y, Guo Y, Wu C, Shen N, Jiang Y, Wang J (2012) Prediction and identification of T cell epitopes in the H5N1 influenza virus nucleoprotein in chicken. *PLoS One* 7(6):e39344

20. Norup LR, Dalgaard TS, Pedersen AR, Juul-Madsen HR (2011) Assessment of Newcastle disease-specific T cell proliferation in different inbred MHC chicken lines. *Scand J Immunol* 74:23–30
21. Haghighi HR, Read LR, Haeryfar SM, Behboudi S, Sharif S (2009) Identification of a dual-specific T cell epitope of the hemagglutinin antigen of an h5 avian influenza virus in chickens. *PLoS One* 4(11):e7772
22. Reemers SS, van Haarlem DA, Sijts AJ, Vervelde L, Jansen CA (2012) Identification of novel avian influenza virus derived CD8+ T-cell epitopes. *PLoS One* 7(2):e31953
23. Ariaans MP, van de Haar PM, Hensen EJ, Vervelde L (2009) Infectious bronchitis virus induces acute interferon-gamma production through polyclonal stimulation of chicken leukocytes. *Virology* 385:68–73
24. Miller MM, Bacon LD, Hala K, Hunt HD et al (2004) 2004 Nomenclature for the chicken major histocompatibility (B and Y) complex. *Immunogenetics* 56:261–279
25. Barta O, Barta V, Pierson FW (1992) Optimum conditions for the chicken lymphocyte transformation test. *Avian Dis* 36:945–955
26. Schaefer AE, Scafuri AR, Fredericksen TL, Gilmour DG (1985) Strong suppression by monocytes of T cell mitogenesis in chicken peripheral blood leukocytes. *J Immunol* 135:1652–1660
27. Maecker HT, Ghanekar SA, Suni MA, He XS et al (2001) Factors affecting the efficiency of CD8+ T cell cross-priming with exogenous antigens. *J Immunol* 166:7268–7275
28. Lavoie ET, Grasman KA (2005) Isolation, cryopreservation, and mitogenesis of peripheral blood lymphocytes from chickens (*Gallus domesticus*) and wild herring gulls (*Larus argentatus*). *Arch Environ Contam Toxicol* 48:552–558
29. Brenchley JM, Douek DC (2004) Flow cytometric analysis of human antigen-specific T-cell proliferation. *Methods Cell Biology* 75:481–496

Generation of Newcastle Disease Virus (NDV) Recombinants Expressing the Infectious Laryngotracheitis Virus (ILT) Glycoprotein gB or gD as Dual Vaccines

Wei Zhao, Stephen Spatz, Laszlo Zsak, and Qingzhong Yu

1 Introduction

Infectious laryngotracheitis (ILT) is a highly contagious acute respiratory disease of chickens that has become a major problem in the US poultry industry in recent years [1]. The disease is controlled mainly through biosecurity and vaccination with live attenuated strains of infectious laryngotracheitis virus (ILT) and vectored vaccines based on turkey herpesvirus (HVT) and fowlpox virus (FPV) [2–5]. The current live attenuated vaccines (chicken embryo origin [CEO] and tissue culture origin [TCO]), although effective, can regain virulence. ILT vaccines based on HVT and FPV vectors are less efficacious than live attenuated vaccines [5–7]. Therefore, there is a pressing need to develop safer and more efficacious ILT vaccines.

Newcastle disease virus (NDV) is the causative agent of Newcastle disease (ND), one of the most important poultry diseases worldwide, affecting a wide variety of birds and causing significant economic losses to the poultry industry [8]. The NDV LaSota strain, a naturally occurring low-virulence NDV strain, has been routinely used as a live vaccine throughout the world [9]. This vaccine strain induces strong immunity both locally and systemically and can be readily administered through drinking water supplies or by direct spray [10]. For the last 60 years, the LaSota vaccine has been proven to be safe and stable, with no reports of reversion to virulence or recombination with field strains. During the past decade, the LaSota vaccine and other NDV strains have been developed as vectors using reverse genetics technology in order to express foreign genes for vaccine or gene therapy purposes [11–13].

Here, we describe the strategy and protocol for the construction of NDV LaSota vaccine strain-based cDNA clones vectoring the glycoprotein genes (gB and gD) of ILTV and the rescue of infectious NDV recombinants from cloned cDNAs, as dual vaccines against ILT and ND using reverse genetics technology.

2 Materials

2.1 Cloning ILTV gB and gD Genes

1. The ILTV strain (63140/C/08/BR) [14].
2. 10 mM deoxynucleotide triphosphate (dNTP) mix (New England Biolabs, Ipswich, MA).
3. Primers used for cloning:
 - Plant-gB/GFP F: 5'-ATAGTTGTAGCACCATGCAATCCTA CATCG-3'.
 - Plant-gB/GFP R: 5'-GTAGTTACACACAGCTTATTTCGTCT TCGCTTTC-3'.
 - Plant-gD/GFP F: 5'-ATAGTTGTAGCACCATGCACCGTCC TCATC-3'.
 - Plant-gD/GFP R: 5'-GTAGTTACACACAGCTTAGCTACG CGCGCAT-3'.
4. *PfuUltra* II fusion HS DNA polymerase (Agilent Technologies, La Jolla, CA).
5. Agarose.
6. 1× TAE buffer.
7. 1 kb Plus DNA Ladder (Life Technologies, Carlsbad, CA).
8. SYBR® Safe DNA gel stain (Life Technologies).
9. QIAquick gel extraction kit (Qiagen, Valencia, CA).
10. Isopropanol.

2.2 Preparation of a Linearized NDV Vector

1. The pLS-GFP plasmid [15].
2. Primers used for linearizing NDV vector:
 - Insert vec up: 5'-GGTGGCTACAACCTATCAACTAAACT-3'.
 - Insert vec down: 5'-GTGTGTAACCTACCGTGTACTAAGC-3'.
3. *PfuUltra* II fusion HS DNA polymerase (Agilent Technologies).
4. *DpnI* (New England Biolabs).
5. Agarose.
6. 1× TAE buffer.
7. 1 kb Plus DNA Ladder (Life Technologies).
8. SYBR® Safe DNA gel stain (Life Technologies).
9. QIAquick gel extraction kit (Qiagen).
10. Isopropanol.

2.3 In-Fusion Cloning and Transformation

1. In-Fusion PCR cloning kit (Clontech, Mountain View, CA).
2. 17 × 100 mm Falcon® 2059 tubes (Falcon, Oxnard, CA).
3. MAX Efficiency® Stbl2 competent cells (Life Technologies).
4. Ampicillin containing bacterial selection LB (Luria Broth, Difco) agar plates.
5. QIAprep Spin Miniprep Kit (Qiagen).

2.4 PCR Screening Ligation Mix and Purified Plasmid

1. *PfuUltra* II fusion HS DNA polymerase (Agilent Technologies).
2. Primers used in screening:
Sequencing primer forward: 5'-AGTTTAGTTGATAGTT GTA-3'.
Sequencing primer reverse: 5'-GTACACGGTAGTTACA CAC-3'.
3. *DpnI* (New England Biolabs, Ipswich, MA).
4. Agarose.
5. 1 × TAE buffer.
6. 1 kb Plus DNA Ladder (Life Technologies).
7. SYBR® Safe DNA gel stain (Life Technologies).
8. QIAprep Spin Miniprep Kit (Qiagen).

2.5 Virus Rescue and Propagation

1. The HEP-2 (CCL-81; ATCC) cell line was grown in growth medium at 37 °C in a 5 % CO₂ atmosphere.
2. Cell growth medium: Dulbecco's Modified Eagle's Medium (DMEM) (Life Technologies) supplemented with 10 % fetal bovine serum (FBS) (Life Technologies) and antibiotics (100 U/ml penicillin, 100 µg/ml streptomycin, and 0.25 µg/ml amphotericin B; Thermo Scientific, Suwanee, GA).
3. Cell maintenance medium: DMEM (Life Technologies) supplemented with 2 % FBS (Life Technologies) and antibiotics (100 U/ml penicillin, 100 µg/ml streptomycin, and 0.25 µg/ml amphotericin B; Thermo Scientific, Suwanee, GA).
4. The modified vaccinia Ankara/T7 recombinant virus (MVA-T7) used during virus rescue to provide the bacteriophage T7 RNA polymerase [16].
5. Lipofectamine® 2000 transfection reagent (Life Technologies).
6. Opti-MEM® I Reduced Serum Medium (Life Technologies).
7. NDV transfection supporting plasmids (pTM-NP, pTM-P, pTM-L) [17].
8. 6-well flat bottom cell culture plate.
9. 1 ml syringe (BD, Franklin Lakes, NJ).
10. 9-day-old specific pathogen-free (SPF) chicken embryos.
11. Glue (Elmer's Products, Inc., Westerville, OH).

2.6 Hemagglutination (HA) Test

1. 0.5 % SPF chicken red blood cells.
2. 96-well round-bottomed microplates.
3. Phosphate-buffered saline (1× PBS) buffer (Life Technologies).

2.7 Immuno-fluorescence Assay (IFA)

1. Anti-ILTV chicken serum [15].
2. NDV-specific monoclonal antibody (MAb) against the HN protein [15].
3. 10 % zinc formalin (Fisher Scientific, Pittsburgh, PA).
4. 0.5 % Triton X-100 (Sigma, St. Louis, MO).
5. Blocking buffer: 1× PBS containing 5 % goat serum (SouthernBiotech, Birmingham, AL).
6. Fluorescein isothiocyanate (FITC)-labeled goat anti-chicken IgG (H+L) (SouthernBiotech).
7. Alexa Fluor® 568 goat anti-mouse IgG (H+L) antibody, highly cross-adsorbed (Life Technologies).
8. The DF-1 (CRL-12203; ATCC) cell line was grown in growth medium at 37 °C in a 5 % CO₂ atmosphere.
9. Cell growth medium: DMEM (Life Technologies) supplemented with 10 % fetal bovine serum (FBS) (Life Technologies) and antibiotics (100 U/ml penicillin, 100 µg/ml streptomycin, and 0.25 µg/ml amphotericin B; Thermo Scientific).
10. Virus supporting medium: DMEM (Life Technologies) supplemented with 2 % FBS (Life Technologies), 10 % allantoic fluid and antibiotics (100 U/ml penicillin, 100 µg/ml streptomycin, and 0.25 µg/ml amphotericin B; Thermo Scientific).
11. 1× PBS (Life Technologies).

3 Methods

3.1 Cloning ILTV gB and gD Genes

1. Gently vortex mix and briefly centrifuge all PCR solutions after thawing.
2. For amplifying the gB gene of ILTV: Place a thin-walled PCR tube on ice and add the PCR amplification reagents: 10× *PfuUltra* HF reaction buffer, 5.0 µl; dNTPs (25 mM each dNTP), 1.0 µl; 10 µM forward primer (Plant-gB/GFP F), 1.0 µl; 10 µM reverse primer (Plant-gB/GFP R), 1.0 µl; genomic DNA of ILTV strain 63140/C/08/BR, 100 ng; *PfuUltra* HF DNA polymerase (2.5 U/µl), 1.0 µl; and distilled water (dH₂O) up to 50.0 µl.
3. For amplifying the gD gene of ILTV: Place a thin-walled PCR tube on ice and add the PCR amplification reagents: 10× *PfuUltra* HF reaction buffer, 5.0 µl; dNTPs (25 mM each

dNTP), 1.0 μ l; 10 μ M forward primer (Plant-gD/GFP F), 1.0 μ l; 10 μ M reverse primer (Plant-gD/GFP R), 1.0 μ l; genomic DNA of ILTV strain 63140/C/08/BR, 100 ng; *PfuUltra* HF DNA polymerase (2.5 U/ μ l), 1.0 μ l; and distilled water (dH₂O) up to 50.0 μ l.

4. Gently mix the reaction and collect all liquid to the bottom of the tube by a short low centrifugation spin if necessary (*see Note 1*).
5. Two reaction mixtures are subjected to the amplification thermocycling conditions as follows: After initial denaturation at 95 °C for 30 s, 30 cycles of amplification were performed, with 95 °C for 20 s denaturation time, 55 °C for 20 s annealing, 68 °C for 2 min extension, and a final extension of 68 °C for 10 min.
6. Measure out 1.0 g of agarose and pour into the microwavable flask along with 100 ml of 1 \times TAE (*see Note 2*).
7. Microwave for 1–3 min (until the agarose is completely dissolved). Let the agarose solution cool down for 5 min. Add 10 μ l of 10,000 \times SYBR[®] Safe stain concentrate to the solution and pour the agarose into a gel tray with the well comb in place (*see Note 3*).
8. Let the newly poured gel sit at room temperature for 20–30 min, until it has completely solidified.
9. Place the gel in electrophoresis chamber and submerge the gel completely with 1 \times TAE.
10. Load the appropriate amount (4–10 μ l) of the PCR products and the DNA marker on the gel. Run the gel at 80–150 V until the dye line is approximately 75–80 % down the length of the gel. Use any device that has UV light to visualize and analyze the DNA fragments (*see Note 4*).
11. Excise the DNA fragment from the agarose gel using a clean, sharp scalpel (*see Note 5*).
12. Weigh the gel slice in a colorless tube. Add three volumes of buffer QG to one volume of gel (100 mg–100 μ l) (*see Note 6*).
13. Incubate at 50 °C for 10 min (or until the gel slice has completely dissolved). To help dissolve gel, mix on a vortex mixer every 2–3 min during the incubation.
14. After the gel slice has dissolved completely, check to ensure the color of the mixture remained yellow (similar to buffer QG without dissolved agarose) (*see Note 7*).
15. Add 1 gel volume of isopropanol to the sample and mix (*see Note 8*).
16. Place a QIAquick spin column in a 2 ml collection tube.

17. To bind the DNA, apply the sample from **step 15** to the QIAquick column, and centrifuge at $16,100 \times g$ ($\sim 13,200$ rpm) for 1 min in a conventional, tabletop microcentrifuge.
18. Discard the flow-through and place the QIAquick column back in the same collection tube.
19. Wash the QIAquick column with 0.75 ml of buffer PE and centrifuge for 1 min.
20. Discard the flow-through and recentrifuge the QIAquick column for an additional 1 min at $16,100 \times g$ ($\sim 13,200$ rpm) (*see Note 9*).
21. Place QIAquick column into a clean 1.5 ml microcentrifuge tube.
22. Elute the DNA with 50 μ l buffer EB (10 mM Tris-Cl, pH 8.5) or H₂O, let the column stand for 1 min, and then centrifuge for 1 min at $16,100 \times g$ ($\sim 13,200$ rpm) (*see Note 10*).

3.2 Preparation of a Linearized NDV Vector

1. Place a thin-walled PCR tube on ice and add the PCR amplification reagents: 10 \times *PfuUltra* HF reaction buffer, 5.0 μ l; dNTPs (25 mM each dNTP), 1.0 μ l; 10 μ M forward primer (insert vec down), 1.0 μ l; 10 μ M reverse primer (Insert vec Up), 1.0 μ l; the pLS-GFP plasmid, 100 ng; *PfuUltra* HF DNA polymerase (2.5 U/ μ l), 1.0 μ l; and distilled water (dH₂O) up to 50.0 μ l.
2. Gently mix the reaction by pipetting up and down and microfuge briefly.
3. The reaction mixture is subjected to the amplification thermocycling conditions as follows: After initial denaturation at 95 °C for 30 s, 30 cycles of amplification were performed, with 95 °C for 20 s denaturation time, 55 °C for 20 s annealing, 68 °C for 10 min extension, and a final extension of 68 °C for 10 min.
4. Analyze the PCR amplification product on a 0.7–1.0 % (w/v) agarose gel as described above.
5. Remove residual pLS-GFP plasmid contamination by *Dpn* I digestion. Set up the following reaction: 44.0 μ l of gel extracted PCR product, 5.0 μ l of 10 \times CutSmart buffer, and 1.0 μ l of *Dpn* I.
6. Gently mix the reaction and then incubate at 37 °C for 1 h.
7. Run an agarose gel and then purified the NDV vector by using gel extraction kit as described above.

3.3 In-Fusion Cloning and Transformation

1. Set up the In-Fusion cloning reaction as follows: 2 μ l of 5 \times In-Fusion HD enzyme premix, 150 ng of gB or gD gene of ILTV, and 400 ng of linearized vector.
2. Adjust the total reaction volume to 10 μ l using deionized H₂O.

3. Gently mix the reaction by pipetting up and down and microfuge briefly.
4. Incubate the reaction for 15 min at 50 °C, and then place on ice.
5. Thaw competent cells on wet ice. Place the required number of 17×100 mm Falcon® 2059 tubes or similarly shaped polypropylene tubes on ice (*see Note 11*).
6. Gently mix the cells, and then aliquot 100 µl of competent cells into chilled tubes.
7. Refreeze any unused cells in a dry ice/ethanol bath for 5 min before returning them to the -85 to -68 °C freezer. Do not use liquid nitrogen (*see Note 12*).
8. Dilute the In-Fusion reaction mix with five volumes of 1× TE [10 mM Tris-HCl (pH 7.5) and 1 mM EDTA]. Add 1 µl of the diluted DNA to the cells, moving the pipette through the cells while dispensing the DNA. Gently tap the tubes to mix.
9. Incubate the cells on ice for 30 min.
10. Heat-shock the cells for 25 s in a 42 °C water bath; do not shake the cells.
11. Place the cells on ice for 2 min.
12. Add 0.9 ml of room-temperature SOC medium (*see Note 13*).
13. Shake the tubes containing transformed *E. coli* at 225 rpm (30 °C) for 90 min.
14. Spread 100 µl of this reaction mix on LB plates with 100 µg/ml ampicillin.
15. Incubate plates overnight at 37 °C.

3.4 PCR Screening and Plasmid Purification

1. Determine the number of colonies to be tested.
2. Assemble the following PCR mixture per reaction: 1.0 µl of 10× *PfuUltra* HF reaction buffer; 0.2 µl of dNTPs (25 mM each dNTP); 0.2 µl of 10 µM sequencing primer forward; 0.2 µl of 10 µM sequencing primer reverse; 0.2 µl of *PfuUltra* HF DNA polymerase (2.5 U/µl); and 7.2 µl of distilled water (dH₂O).
3. Use a micropipette tip to pick a single colony. Insert the tip into the PCR mixture and pipette up and down.
4. Reserve the bacteria from each PCR mixture by removing 1 µl and placing into 100 µl of LB broth in a labeled tube.
5. Conduct PCR according to the following thermal cycling profile: 95 °C for 10 min, 30 cycles of 95 °C for 20 s, 55 °C for 20 s, 68 °C for 1 min extension, and a final extension at 68 °C for 10 min.
6. Run the amplification reactions on an agarose gel to identify the positive clone.

7. Add 3 ml of LB broth with 100 µg/ml ampicillin to desired clones from the reserved bacteria, and incubate for 12–16 h at 37 °C with vigorous shaking (*see Note 14*).
8. Harvest the bacterial cells by centrifugation at 5900×g (~8000 rpm) in a conventional, tabletop microcentrifuge for 3 min at room temperature (*see Note 15*).
9. Resuspend pelleted bacterial cells in 250 µl buffer P1 and transfer to a microcentrifuge tube (*see Note 16*).
10. Add 250 µl buffer P2 and mix thoroughly by inverting the tube four to six times (*see Note 17*).
11. Add 350 µl buffer N3 and mix immediately and thoroughly by inverting the tube four to six times (*see Note 18*).
12. Centrifuge for 10 min at 16,100×g (~13,200 rpm) in a table-top microcentrifuge.
13. Apply the supernatants from **step 4** to the QIAprep spin column by decanting or pipetting.
14. Centrifuge for 30–60 s. Discard the flow-through.
15. Wash QIAprep spin column by adding 0.75 ml buffer PE and centrifuging for 30–60 s.
16. Discard the flow-through, and centrifuge at full speed for an additional 1 min to remove residual wash buffer (*see Note 19*).
17. Place the QIAprep column in a clean 1.5 ml microcentrifuge tube. To elute DNA, add 50 µl buffer EB (10 mM Tris-Cl, pH 8.5) or water to the center of each QIAprep spin column, let stand for 1 min, and centrifuge for 1 min.
18. The resulting recombinants are designated pLS/ILTV-gB (carrying gB gene of ILTV) or pLS/ILTV-gD (carrying gD gene of ILTV).

3.5 Virus Rescue and Propagation

1. One day before transfection, HEP-2 cells were seeded at 1×10^6 cells/well in 6-well tissue culture plate with a volume of 3 ml growth medium without antibiotics per well, so that they will be 90–95 % confluent at the time of transfection (*see Note 20*).
2. For each transfection sample, prepare DNA-Lipofectamine 2000 complexes as follows:
 - (a) Add 2 µl of pLS/ILTV-gB or pLS/ILTV-gD (1.0 µg/µl) along with 1 µl of pTM-NP (1.0 µg/µl), 1.0 µl of pTM-P (500 ng/µl), and 1.0 µl of pTM-L (100 ng/µl) to 250 µl of Opti-MEM® I Reduced Serum Medium without serum in a microcentrifuge tube at room temperature. Mix gently.
 - (b) Mix Lipofectamine 2000 gently before use, and then dilute 6 µl of Lipofectamine 2000 in 250 µl of Opti-MEM® I Reduced Serum Medium without antibiotics in a microcentrifuge tube. Gently mix and incubate at RT for 5 min (*see Note 21*).

- (c) After the 5 min incubation, combine the diluted DNA with the diluted Lipofectamine 2000. Mix gently and incubate for 20 min at room temperature to allow the DNA-Lipofectamine 2000 complexes to form. The solution may appear cloudy, but this will not inhibit the transfection.
3. Wash HEp-2 cells once with 3 ml 1× PBS, and then wash with 1 ml of Opti-MEM® I Reduced Serum Medium without antibiotics to remove traces of PBS.
4. Sonicate the MVA-T7 virus twice for 1 min, and then infect HEp-2 cells at a multiplicity of infection (MOI) of 3 to provide the T7 polymerase.
5. Add the DNA-Lipofectamine 2000 complexes to the corresponding well. Mix gently by rocking the plate back and forth.
6. Incubate the cells at 37 °C in a CO₂ incubator for 6 h.
7. At 6 h post-transfection, remove the culture medium containing the DNA-Lipofectamine complexes and wash the cells once with 3 ml of 1× PBS and then add 3 ml of cell maintenance medium.
8. Incubate the cells at 37 °C for 3 days.
9. At 72 h post-infection, the rescued virus, rLS/ILTV-gB or rLS/ILTV-gD, is harvested by freeze-thawing the infected cells three times.
10. Candle the egg and select an area of the chorioallantoic membrane free of large blood vessels. Discard any eggs that are infertile, have cracks, are underdeveloped, or that appear to have a porous shell.
11. Wipe the tops of the eggs with 70 % ethanol and drill a small hole through the shell over the air sac.
12. Aspirate 1 ml of infected cells into a tuberculin syringe with a 22 gauge, 1½ in. needle.
13. Insert the needle into the hole of the egg. Use a short stabbing motion, pierce the amniotic membrane, and inoculate 100 µl into the amniotic cavity.
14. Seal the holes in the eggs with a drop of glue.
15. Incubate the eggs at 37 °C in an egg incubator for 4 days.

3.6 HA Test

1. Eggs are chilled at 4 °C overnight or for 4 h before testing.
2. Add 50 µl PBS to each well.
3. Use a micropipette to remove 50 µl of allantoic fluid from each egg and dispense into the first column.
4. Mix each well and transfer 50 µl to the next well on its right. Perform a serial dilution using a 50 µl microtiter transfer. Discard 50 µl from the last well into a bleach solution.

5. Add 50 μ l of 0.5 % red blood cell to each well. Mix gently.
6. Leave at room temperature for 30–60 min to agglutinate.
7. The HA-positive allantoic fluid is used to amplify the rescued virus in SPF chicken embryos three times and then harvested.

3.7 Immuno- fluorescence Assay (IFA)

1. Grow the DF-1 cells in 6-well plate with 3 ml cell growth medium for 24 h.
2. Remove the medium from the cells and infect cells with the recombinant viruses (rLS/ILTV-gB or rLS/ILTV-gD) at an MOI of 0.01.
3. Allow inoculum to adsorb for 1 h at 37 °C.
4. Remove the medium containing unabsorbed virus and add 3 ml of cell maintenance medium.
5. Incubate at 37 °C for 24 h.
6. At 24 h post-infection, the infected cells are washed three times with 1 \times PBS and are fixed with 10 % zinc formalin for 15 min at room temperature.
7. Add 0.5 % Triton X-100 in 1 \times PBS to permeabilize the cells for 10 min at room temperature.
8. Block the permeabilized cells with blocking buffer for 30 min at 37 °C.
9. Incubate with a mixture of anti-ILTV serum and mouse anti-NDV HN MAb.
10. Wash cells with 1 \times PBS and incubate with a mixture of fluorescein isothiocyanate (FITC)-labeled goat anti-chicken IgG (H+L) (1:1000 dilution in blocking buffer) and Alexa Fluor 568-conjugated goat anti-mouse IgG (1:1000 dilution in blocking buffer) for 1 h at 37 °C.
11. Monitor and digitally photograph the fluorescence images using an inverted fluorescence microscope at a magnification of 100 \times with matching excitation/emission filters for FITC or Alexa Fluor 568. The ILTV-gB or ILTV-gD protein should be stained with green fluorescence, whereas the NDV HN protein will be stained with red fluorescence.

4 Notes

1. Transfer PCR tubes from ice to a PCR machine with the block preheated to 95 °C and begin thermocycling. When using thermal cyclers without a heated lid, overlay the reaction mixture with 25 μ l of mineral oil.
2. Agarose gels are commonly used in concentrations of 0.7–2 % depending on the size of bands needed to be separated. Simply

adjust the amount of starting agarose to % g/100 ml 1× TAE (i.e., 2 g/100 ml will give you 2 %). TBE can be used instead of TAE, labs usually use one or the other, but there is very little difference between the two. However, elution of DNA from 1× TBE agarose slices can be problematic.

3. Pour slowly to avoid bubbles which will disrupt the gel. Any bubbles can be pushed away from the well comb or toward the sides/edges of the gel with a pipette tip.
4. When using UV light, protect your skin by wearing safety goggles or a face shield, gloves, and a lab coat. Expose the gel for the shortest time possible to minimize UV damage to the DNA.
5. Minimizing the gel slice size by removing extra agarose around the DNA band will increase the yield of DNA.
6. For >2 % agarose gels, add six volumes of buffer QG.
7. If the color of the mixture is orange or violet, add 10 µl of 3 M sodium acetate, pH 5.0, and mix. The color of the mixture will turn to yellow.
8. For example, if the agarose gel slice is 100 mg, add 100 µl isopropanol. This step increases the yield of DNA fragments <500 bp and >4 kb. For DNA fragments between 500 bp and 4 kb, addition of isopropanol has no effect on yield. Do not centrifuge the sample at this stage.
9. Residual ethanol from buffer PE will not be completely removed unless the flow-through is discarded before the additional centrifugation.
10. Ensure that the elution buffer is dispensed directly onto the QIAquick membrane for complete elution of bound DNA. Elution efficiency is dependent on pH. The maximum elution efficiency is achieved between pH 7.0 and 8.5. When using water, make sure that the pH value is within this range, and store the DNA at -20 °C as DNA may degrade in the absence of a chelating agent. The purified DNA can also be eluted in TE (10 mM Tris-Cl, 1 mM EDTA, pH 8.0), but the EDTA may inhibit subsequent enzymatic reactions.
11. Falcon® 2059 tubes or other similarly shaped 17×100 mm polypropylene tubes are required for optimal transformation efficiency. You may use microcentrifuge tubes (1.5 ml), but the transformation efficiency will be reduced three- to tenfold.
12. For optimal results, thaw each vial of cells only once. Although the cells can be refrozen, subsequent freeze-thaw cycles will lower the transformation frequency by approximately twofold.

13. You may use media other than SOC medium, but the transformation efficiency will be reduced. Suspension in Luria Broth can reduce transformation efficiency by a minimum of two- to threefold.
14. Growth for more than 16 h is not recommended since cells begin to lyse and plasmid yields may be reduced. Use a tube or flask with a volume of at least four times the volume of the culture.
15. Remove all traces of supernatant by inverting the open centrifuge tube until all medium has been drained.
16. Ensure that RNase A has been added to buffer P1. No cell clumps should be visible after suspension of the pellet. The bacteria should be dissolved, suspended completely by vortex mixing or pipetting up and down until no cell clumps are visible.
17. Mixing should result in a homogeneously colored suspension. If the suspension contains localized colorless regions or if brownish cell clumps are still visible, continue mixing the solution until a homogeneously colored suspension is achieved.
18. To avoid localized precipitation, mix the solution thoroughly, immediately after addition of buffer N3. The solution should become cloudy with white floccules.
19. Residual wash buffer will not be completely removed unless the flow-through is discarded before the additional centrifugation. Residual ethanol from buffer PE may inhibit subsequent enzymatic reactions.
20. Transfect cells at a high cell density. 90–95 % confluency at the time of transfection is recommended to obtain high efficiency and expression levels and to minimize decreased cell growth associated with high transfection activity. Lower cell densities are suitable with optimization of conditions. Take care to maintain a standard seeding protocol between experiments because transfection efficiency is sensitive to culture confluence. Do not add antibiotics to media during transfection as this will cause cell death.
21. Combine the diluted Lipofectamine 2000 with the diluted DNA within 5 min. Longer incubation times may decrease activity.

Acknowledgements

The authors wish to thank Xiuqin Xia and Fenglan Li for their excellent technical assistance. This work was supported by USDA, ARS CRIS project 6040-32000-065-00D.

References

1. Garcia M, Spatz S, Guy JS (2013) Infectious laryngotracheitis. In: Swayne DE et al (eds) *Diseases of poultry*, 13th edn. Wiley-Blackwell Publishing, Ames, IA, USA, pp 161–179
2. Davison S, Gingerich EN, Casavant S, Eckroade RJ (2006) Evaluation of the efficacy of a live fowlpox-vectored infectious laryngotracheitis/avian encephalomyelitis vaccine against ILT viral challenge. *Avian Dis* 50:50–54
3. Menendez KR, Garcia M, Spatz S, Tablante NL (2014) Molecular epidemiology of infectious laryngotracheitis: a review. *Avian Pathol* 43:108–117
4. Tong GZ, Zhang SJ, Wang L, Qiu HJ, Wang YF, Wang M (2001) Protection of chickens from infectious laryngotracheitis with a recombinant fowlpox virus expressing glycoprotein B of infectious laryngotracheitis virus. *Avian Pathol* 30:143–148
5. Vagnozzi A, Zavala G, Riblet SM, Mundt A, Garcia M (2012) Protection induced by commercially available live-attenuated and recombinant viral vector vaccines against infectious laryngotracheitis virus in broiler chickens. *Avian Pathol* 41:21–31
6. Guy JS, Barnes HJ, Morgan LM (1990) Virulence of infectious laryngotracheitis viruses: comparison of modified-live vaccine viruses and North Carolina field isolates. *Avian Dis* 34:106–113
7. Guy JS, Barnes HJ, Smith L (1991) Increased virulence of modified-live infectious laryngotracheitis vaccine virus following bird-to-bird passage. *Avian Dis* 35:348–355
8. Miller PJ, Guus K (2013) Newcastle disease. In: Swayne DE et al (eds) *Diseases of poultry*, 13th edn. Wiley-Blackwell Publishing, Ames, IA, USA, pp 98–107
9. Goldhaft TM (1980) Historical note on the origin of the LaSota strain of Newcastle disease virus. *Avian Dis* 24:297–301
10. Meulemans G (1988) Control by vaccination. In: Alexander DJ (ed) *Newcastle disease*. Kluwer Academic Publishers, Boston, MA, pp 318–332
11. Huang Z, Elankumaran S, Panda A, Samal SK (2003) Recombinant Newcastle disease virus as a vaccine vector. *Poult Sci* 82:899–906
12. Schirrmacher V, Fournier P (2009) Newcastle disease virus: a promising vector for viral therapy, immune therapy, and gene therapy of cancer. *Methods Mol Biol* 542:565–605
13. Zhao H, Peeters BP (2003) Recombinant Newcastle disease virus as a viral vector: effect of genomic location of foreign gene on gene expression and virus replication. *J Gen Virol* 84:781–788
14. Spatz SJ, Volkening JD, Keeler CL, Kutish GF, Riblet SM, Boettger CM, Clark KF, Zsak L, Afonso CL, Mundt ES, Rock DL, Garcia M (2012) Comparative full genome analysis of four infectious laryngotracheitis virus (*Gallid herpesvirus-1*) virulent isolates from the United States. *Virus Genes* 44:273–285
15. Zhao W, Spatz S, Zhang Z, Wen G, Garcia M, Zsak L, Yu Q (2014) Newcastle disease virus (NDV) recombinants expressing infectious laryngotracheitis virus (ILTV) glycoproteins gB and gD protect chickens against ILTV and NDV challenges. *J Virol* 88:8397–8406
16. Wyatt LS, Moss B, Rozenblatt S (1995) Replication-deficient vaccinia virus encoding bacteriophage T7 RNA polymerase for transient gene expression in mammalian cells. *Virology* 210:202–205
17. Estevez CN, King DJ, Seal B, Yu Q (2007) Evaluation of Newcastle disease virus chimeras expressing the Hemagglutinin-Neuraminidase protein of velogenic strains in the context of a mesogenic recombinant virus backbone. *Virus Res* 129:182–190

A Reverse Genetics Approach for the Design of Methyltransferase-Defective Live Attenuated Avian Metapneumovirus Vaccines

Yu Zhang, Jing Sun, Yongwei Wei, and Jianrong Li

1 Introduction

Avian metapneumovirus (aMPV), also known as avian pneumovirus (APV) or turkey rhinotracheitis virus, is an economically important pathogen that causes an acute, highly contagious respiratory disease in turkeys and is the etiological agent of “swollen head syndrome” in chickens [1, 2]. Since the isolation of aMPV in South Africa in 1978, the virus has become prevalent worldwide [1–4]. Based on antigenicity and genetic diversity, four subtypes of aMPV, designated A, B, C, and D, have been characterized [2]. Subtypes A, B, and D are found mainly in Europe and Asia [3–6]. In the USA, aMPV was first identified in 1996, in a commercial turkey flock with respiratory disease in Colorado [7]. The virus was classified as subtype C due to low sequence identity to subtype A and B viruses [7–9]. Subsequently, it emerged in turkey flocks in Minnesota and became a major problem in the turkey industry in the USA [8–12]. Epidemiological studies suggest that aMPV subtype C is distributed in a wide range of avian species such as chickens, ducks, geese, American crows, cattle egrets, American coots, and pigeons. A recent phylogenetic analysis showed that two distinct sub-lineages of aMPV subtype C exist in the USA [11]. Clinical signs of aMPV in turkeys are characterized by coughing, sneezing, nasal discharge, and swollen infraorbital sinuses. Infected flocks have high morbidity (50–100 %) at all ages, with mortality ranging from 0.5 % in adult turkeys to 80 % in young poultry [6–11]. Direct economic losses caused by this virus include poor weight gain, sharply reduced egg production, poor egg quality, and high morbidity and mortality.

aMPV is a non-segmented negative-sense (NNS) RNA virus, belonging to the genus *Metapneumovirus* in the subfamily *Pneumovirinae* of the family *Paramyxoviridae*. The only other member in the genus *Metapneumovirus* is human metapneumovirus (hMPV), which was first identified in infants and children with acute respiratory tract infections in 2001 in the Netherlands [13]. Soon after its discovery, hMPV was recognized as a globally prevalent pathogen and is a major causative agent of acute respiratory tract disease in individuals of all ages, especially infants, children, the elderly, and immunocompromised individuals [14, 15]. Interestingly, aMPV subtype C shares more homology with hMPV than the other three aMPV subtypes. In addition, turkeys were shown to be susceptible to hMPV infection [16]. Paramyxoviruses include many other important human pathogens such as human respiratory syncytial virus (RSV), human parainfluenza virus type 3 (PIV3), measles virus, and mumps virus. The family also contains highly lethal emerging pathogens such as Nipah virus and Hendra virus, as well as agriculturally important viruses such as Newcastle disease virus (NDV). For many of these viruses, there are no effective vaccines or antiviral drugs.

The traditional strategy for virus attenuation is to pass the virulent strain blindly in cell culture. Using this strategy, live attenuated aMPV vaccines have been developed in Europe and are used for the prevention of aMPV type A and B viruses [17, 18]. After the emergence of aMPV in the USA, a subtype C strain, aMPV/MN-1a, has been attenuated through 63 serial passages of the virus in cell culture [19, 20]. This strain triggered a considerable level of antibody response and protected poultry from challenge with virulent virus. In addition, a live vectored vaccine candidate has been reported for aMPV [21]. A recombinant Newcastle disease virus (NDV) LaSota strain expressing aMPV attachment glycoprotein (G) was constructed [21]. The resultant bivalent vaccine was immunogenic and provided full protection against NDV but was not sufficient to protect against aMPV infection. Since both surface glycoproteins (attachment glycoprotein G and fusion protein F) are essential for neutralizing antibody production, a single surface protein may not be sufficient to induce protective immunity against aMPV infection. Although these vaccines showed considerable efficacy in commercial turkeys, outbreaks of aMPV still occur worldwide [1, 2, 5–10, 21]. Major problems for these traditional live attenuated vaccines include genetic instability, insufficient attenuation and immunogenicity, and/or poor virus growth in vitro. In fact, several live aMPV vaccines reverted back to virulent strains and became persistent in the field [22, 23]. Therefore, there is an urgent need to develop a more stable and efficacious vaccine for aMPV.

We hypothesize that viral mRNA cap methyltransferase (MTase) is an excellent target to rationally attenuate aMPV for the development of live attenuated vaccines. Messenger RNA modification is

an essential step in paramyxovirus gene expression and replication [24]. During viral RNA synthesis, paramyxoviruses produce capped, methylated, and polyadenylated mRNAs. The paramyxovirus mRNA cap structure is typically methylated at the guanine-N-7 (G-N-7) and ribose 2'-O positions [25–27]. The large (L) polymerase protein of paramyxoviruses catalyzes all of the enzymatic activities for mRNA synthesis and mRNA modifications including capping, methylation, and polyadenylation [28–30]. The conserved region VI (CR VI) of L protein possesses both G-N-7 and ribose-2'-O MTases [26–30]. CR VI of L protein is a typical S-adenosyl methionine (SAM)-dependent MTase containing a catalytic K-D-K-E tetrad and a SAM binding site (GxGxG...D) [26–30]. By introducing mutations in the MTase region in the viral L protein, a panel of recombinant aMPVs that are specifically defective in methylation at positions G-N-7, 2'-O, or both can be generated by a reverse genetics approach. These recombinant aMPVs will exhibit different degrees of attenuation characteristics dependent on the specific methyl group involved and the degree of the defect in mRNA cap methylation (defective in methylation at one position or both positions). By combining multiple substitutions in the MTase region of L protein, it should be possible to generate an attenuated virus that is genetically stable, because reversion to wild type at any single amino acid should not provide a fitness gain.

Using this novel strategy, we recovered a panel of recombinant aMPVs carrying mutations in the SAM binding site of L protein. These recombinant viruses were defective mRNA cap MTase, genetically stable, were attenuated in cell culture and young turkeys, and retained high immunogenicity. Thus, these MTase-defective aMPVs are excellent vaccine candidates for aMPV. Here, we provide detailed materials and methods to generate these MTase-defective aMPVs and methods to evaluate the genetic stability, attenuation, and immunogenicity of these vaccines.

2 Materials

2.1 Preparation of Plasmids and Site-Directed Mutagenesis

1. Plasmid (paMPV) encoding the full-length anti-genomic cDNA of avian metapneumovirus subtype C Colorado strain (aMPV/Colorado/turkey/96).
2. Support plasmids expressing aMPV nucleocapsid (pCDNA3-N), phosphoprotein (pCDNA3-P), large (L) polymerase (pCDNA3-L), and matrix M2-1 (pCDNA3-M2-1).
3. DH5-alpha (NEB) and STBL2 competent cells (Invitrogen), stored at -80°C .
4. QuickChange Site-Directed Mutagenesis Kit (Stratagene, La Jolla, CA).

2.2 Components for Recovery of Avian Metapneumovirus from an Infectious Clone

1. Cell lines. Vero E6 cells (ATCC No. CRL-1586) and BHK-SR19-T7 cells (Apath) were grown in Dulbecco's modified Eagle's medium (DMEM; Life Technologies Bethesda, MD) supplemented with 10 % FBS. The medium of the BHK-SR19-T7 cells was supplemented with 10 µg/mL puromycin (Life Technologies) during every other passage to select for T7 RNA polymerase-expressing cells. LLC-MK2 (ATCC No. CCL-7) cells were maintained in Opti-MEM (Life Technologies) supplemented with 2 % fetal bovine serum (FBS). All cell lines were maintained in a 37 °C incubator with 5 % CO₂ atmosphere.
2. Puromycin dihydrochloride stock solution (10 mg/mL), stored at -20 °C.
3. Lipofectamine 2000 transfection reagent (Life Technologies), stored at 4 °C.

2.3 Avian Metapneumovirus Plaque Assay Reagents

1. Ultrapure low melt point (LMP) agarose (Invitrogen).
2. 1 M HEPES pH 7.7 solution.
3. 7.5 % sodium bicarbonate (NaHCO₃) solution.
4. 1 M l-Glutamine stock solution, stored at -20 °C.
5. Penicillin, kanamycin, and streptomycin stock solution contains 20,000 units of penicillin G, 4 mg of kanamycin, and 4 mg of streptomycin per mL, stored at -20 °C.
6. 10 % formaldehyde in PBS.
7. 0.05 % crystal violet in distilled water.
8. Overlay medium preparation (Table 1).

Table 1
Components for overlay medium

Name	Volume
2× Autoclavable MEM	50 mL
0.75 % Sodium bicarbonate	1.6 mL
1 M HEPES (pH 7.7)	2.5 mL
0.2 M l-Glutamine	1.0 mL
200× Penicillin, streptomycin, kanamycin (PKS) stock solution	0.5 mL
Actinomycin-D stock solution (1 mg/mL)	10 µL
Distilled water	19.4 mL
1 % Agarose solution	25 mL
Total	100 mL

2.4 *In Vitro* trans Methylation Assay Reagents

1. Actinomycin-D stock solution (1 mg/mL), stored at -20°C and avoid exposure to light.
2. Trizol reagent for RNA isolation (Life Technologies).
3. Dynabeads mRNA isolation kit (Life Technologies).
4. [^3H]-S-adenosyl methionine (SAM) (85 Ci/mmol, PerkinElmer, Wellesley, MA).
5. Vaccinia m7G Capping Kit (Cellsript, Madison, WI).
6. Vaccinia 2'-O-Methyltransferase Kit (Cellsript).

2.5 Animal Experiment Reagents

1. Two-week-old specific pathogen-free (SPF) turkeys.
2. 10 % neutral buffered formaldehyde.
3. Hematoxylin and eosin.
4. CO_2 gas cylinder.
5. CO_2 euthanasia chamber.

2.6 Reverse Transcription Polymerase Chain Reaction (RT-PCR) and Sequencing

1. RNeasy Mini Kit (Qiagen).
2. One-step RT-PCR kit (Qiagen).
3. Gene-specific primers targeting aMPV L gene (Table 2).

2.7 Quantification of Viral Genomic RNA by Real-Time RT-PCR

1. RNeasy Mini Kit (Qiagen).
2. Power SYBR Green RNA-to-Ct 1-step kit (Applied Biosystems).
3. Primers targeting aMPV genomic RNA (Table 3).
4. Real-time PCR system (Applied Biosystems).

Table 2
Primers targeting the conserved region VI of aMPV L gene

Primer name	Primer sequence
aMPV-L-12938-Forward	5'-CAGCTCTACCGGTTGCAAATAAGTG TCAAAGCATGT-3'
aMPV-L-13464-Reverse	5'-TAGAAGGACATAACACTCGGATCCTG ACAGTTT-3'

Table 3
Primers used for quantification of aMPV genomic RNA by real-time RT-PCR

Primer name	Primer sequence
aMPV-Le-11-Forward	5'-AAACGCATATAAGACAACCTCCAA-3'
aMPV-N-132-Reverse	5'-AGCTGTGGTTGTCCCCACATCTCT-3'

3 Methods

3.1 Preparation of Plasmids

1. Transform plasmid (paMPV) encoding the aMPV full-length anti-genomic cDNA to STBL2 competent cells following manufacturer's instructions. Transform support plasmids expressing aMPV N (pCDNA3-N), P (pCDNA3-P), L (pCDNA3-L), and M2-1 (pCDNA3-M2-1) to DH5-alpha cells. Plate the cells to agar plates containing 100 µg/mL ampicillin.
2. Incubate the plates at 37 °C incubator for 36–48 h.
3. Pick single colony from the plate and inoculate into 5 mL of LB culture medium in test tubes containing 100 µg/mL ampicillin.
4. Incubate the culture at 37 °C shaking at 200 rpm for 36–48 h.
5. Subculture 2.5 mL of the culture to 100 mL of LB medium containing 100 µg/mL ampicillin and incubate at 37 °C shaking at 200 rpm for 36–48 h.
6. Collect the cells by centrifuge the cultures at 3000×g.
7. Extract five plasmids (paMPV, pCDNA3-N, pCDNA3-P, pCDNA3-L, and pCDNA3-M2-1) from the bacterial cultures using Midi-prep kit following the manufacturer's instructions.
8. Determine the DNA concentration of each plasmid and freeze in aliquots at –20 °C.

3.2 Sequence Analysis of Conserved Region VI of aMPV L Protein

1. Select L proteins of representative members of non-segmented negative-sense RNA viruses from GenBank. The selected L sequences include the *Paramyxoviridae* (HMPV, human metapneumovirus; aMPVC, avian metapneumovirus subtype C; HRSV, human respiratory syncytial virus; BRSV, bovine respiratory syncytial virus; PVM, pneumonia virus of mice; PIV3, parainfluenza virus type 3; NDV, Newcastle disease virus), *Filoviridae* (EBOM, Ebola virus), and *Rhabdoviridae* (VSIV, vesicular stomatitis virus Indiana serotype).
2. Align the conserved domain VI of L proteins with two known 2'-O MTase structures, VP39 and RRMJ using DNA Star software (Lasergene).
3. Identify MTase active site (K-D-K-E tetrad) and SAM binding site (GXGXG ... D).
4. Select amino acids (G1696, G1698, G1700, N1701, and D1755) in SAM binding site for mutagenesis. Each of these amino acid residues is changed to alanine in the L gene of paMPV plasmid.
5. An example of sequence alignment is presented in Fig. 1.

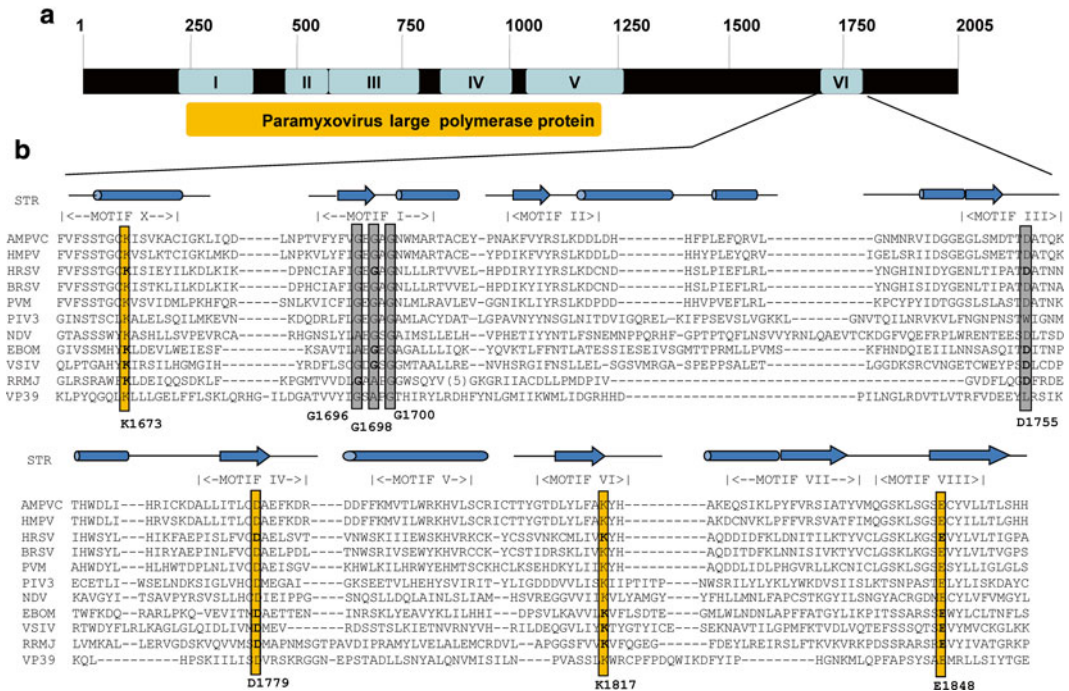

Fig. 1 Sequence alignment of conserved region VI (CR VI) of hMPV L proteins and modeling with two known 2'-O MTase structures, VP39 and RRMJ. **(a)** Conserved regions (CRs) in the L proteins of paramyxoviruses. Amino acid sequence alignment identified six CRs, numbered I to VI, in L proteins. **(b)** Sequence alignment of CR VI in L proteins. STR, structure of RRMJ, and VP39. Predicted or known alpha-helical regions are shown as cylinders, and the beta-sheet regions are shown as arrows. The conserved motifs (motifs X and I to VIII) corresponding to the SAM-dependent MTase superfamily are indicated. The predicted MTase active site (K-D-K-E tetrad) is shown by yellow boxes. The predicted SAM binding site (GXGXX ... D) is shown by gray boxes. The sequences of representative members of the *Paramyxoviridae* (*aMPVC* avian metapneumovirus subtype C, *HMPV* human metapneumovirus, *HRSV* human respiratory syncytial virus, *BRSV* bovine respiratory syncytial virus, *PVM* pneumonia virus of mice, *PIV3* parainfluenza virus type 3, *NDV* Newcastle disease virus), *Filoviridae* (*EBOM*, Ebola virus), and *Rhabdoviridae* (*VSIV*, vesicular stomatitis virus Indiana serotype) are shown

3.3 Site-Directed Mutagenesis

1. Design mutagenesis primers containing the desired mutations and anneal to the same sequence on opposite strand of the plasmid. The forward and reverse primers should be reverse complimentary and both primers should contain the desired mutation in the middle of the primer, with 15–20 bases of correct sequence flanked on both sides.
2. Set up site-directed mutagenesis reaction on thermocycler.
3. Digest the mutagenesis reaction mix by adding 1 unit of Dpn I enzyme.
4. Mix the reaction mix by pipetting and incubate in a 37 °C water bath for 1 h.
5. Transform 1–10 μL STBL2 competent cells according to manufacturer’s instructions.

6. Plate the cells to agar plates containing 100 µg/mL ampicillin.
7. Incubate the plates at 37 °C for 36–48 h.
8. Pick colonies from the plates and inoculate to 5 mL of LB culture medium containing 100 µg/mL ampicillin and incubate in 37 °C shaking (200 rpm) for 36–48 h.
9. Extract plasmid from the cell culture using Qiagen mini-prep kit.
10. Digest wild-type and mutant paMPV plasmids using the Pst I restriction enzyme and incubate at 37 °C for 1 h.
11. Electrophoresis the digestion product on 1 % agarose gel at 100 V for 40 min.
12. Stain the gel in 0.5 µg/mL ethidium bromide for 20 min.
13. Visualize the restriction digestion product under UV light.
14. Compare the digestion pattern of wild-type and mutant paMPV plasmids. The mutant plasmid with a same digestion pattern with wild-type plasmid indicates a correct backbone compared with wild-type plasmid.
15. Sequence the plasmids.
16. Select plasmids containing the desired mutations in CR VI of L gene. These plasmids were designated as paMPV-G1696A, G1698A, G1700A, N1701A, and D1755A.

3.4 Recovery of Recombinant aMPVs from the Full-Length cDNA Clones

1. Seed BHK-SR19-T7 cells to six-well plates 24 h before transfection.
2. Dilute 5.0 µg of paMPV, 2.0 µg of pCDNA3-N, 2.0 µg of pCDNA3-P, 1.0 µg of pCDNA3-L, and 1.0 µg of pCDNA3-M2-1 in 0.5 mL of Opti-MEM and mix gently.
3. Dilute 10 µL of Lipofectamine 2000 to 0.5 mL Opti-MEM. Mix gently and incubate for 5 min at room temperature.
4. Combine the plasmid cocktail with the diluted Lipofectamine 2000 solution, mix gently, and incubate at room temperature for 20 min.
5. Wash BHK-SR19-T7 twice with Opti-MEM.
6. Add the DNA-Lipofectamine 2000 mixture to BHK-SR19-T7 cells and incubate at 30 °C in CO₂ incubator overnight.
7. Remove the DNA-Lipofectamine 2000 mixture 18 h after transfection and add 2 mL of fresh Opti-MEM to each well.
8. Harvest the transfected cells using scrapers at day-4 post-transfection.
9. Coculture the harvested cells with new Vero-E6 cells (50–60 % confluent) and incubate at 37 °C in a CO₂ incubator.

10. Monitor the cytopathic effect (CPE) daily under microscope.
11. Harvest the cells using scrapers when extensive CPE was observed.
12. Freeze cells on dry ice and thaw at room temperature for three cycles.
13. Remove the cell debris by centrifugation at $3000\times g$ for 10 min.
14. Use the supernatant to infect new Vero-E6 cells for further passages.
15. Confirm the recovery of the raMPVs by agarose overlay plaque assay, RT-PCR, and sequencing. These recombinant aMPV mutants were designated as raMPV-G1696A, G1698A, G1700A, N1701A, and D1755A.
16. A diagram for aMPV recovery is presented in Fig. 2.

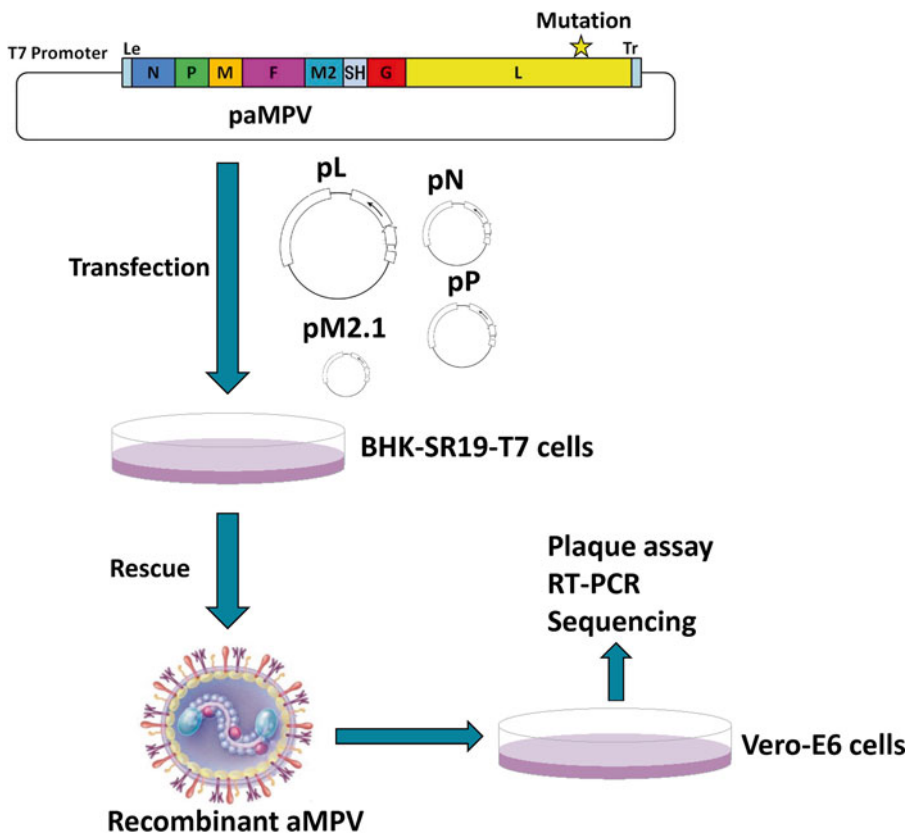

Fig. 2 Recovery of aMPVs from the full-length cDNA clones. Recombinant aMPVs were rescued using a reverse genetics system. Briefly, BHK-SR19-T7 cells which stably express T7 RNA polymerase were transfected with plasmid paMPV carrying the full-length aMPV genome, plasmids expressing viral N, P, L, and M2-1 protein using Lipofectamine 2000. The successful recovery of the aMPVs was confirmed by plaque assay, RT-PCR, and sequencing

3.5 Purification of aMPV

1. Seed Vero-E6 cells in ten T150 flasks and incubate at 37 °C in CO₂ incubator overnight.
2. Infect Vero E6 cells with raMPV mutants at a multiplicity of infection (MOI) of 0.1 in a volume of 2 mL of DMEM.
3. Allow the virus to adsorb for 1 h with constant shaking at 37 °C.
4. Add 20 mL of Opti-MEM containing 2 % FBS and incubate at 37 °C for 4 days.
5. Harvest supernatants and cells when extensive CPE is observed.
6. Clarify the cell suspension by low-speed centrifugation at 3000 × *g* for 20 min at 4 °C.
7. Resuspend the pellet in 2 mL of Opti-MEM and subject to freeze and thaw three times.
8. Remove cell debris from the mixture by centrifugation at 3000 × *g* for 10 min.
9. Combine the supernatants.
10. Pellet down the virus by ultracentrifugation at 28,000 × *g* in a Beckman Ty 50.2 rotor for 2 h.
11. Resuspend the virus pellet in 0.3 mL of Opti-MEM.
12. Freeze the aliquots in a -80 °C freezer.
13. Thaw one vial of virus and determine the titer by plaque assay.

3.6 Determine Viral Replication Kinetics in Vero-E6 Cells

1. Seed Vero E6 cells in six 60-mm dishes.
2. Infect Vero E6 cells by raMPV or mutant raMPV at an MOI of 0.1 in triplicate dishes.
3. Remove the inoculum after 1 h of adsorption.
4. Wash cells three times with PBS.
5. Add fresh DMEM with 2 % FBS.
6. Incubate the infected cells at 37 °C.
7. Take 50 µL of the supernatant from the cells at different time points after infection.
8. Determine viral titer by plaque assay in Vero-E6 cells.
9. aMPV mutants should be attenuated in cell culture. Specifically, aMPV mutants should grow to comparable titer to wild-type aMPV, have significantly delayed viral replication kinetics compared to wild-type aMPV, and have a significantly delayed cytopathic effect (CPE) in cell culture.

3.7 aMPV Plaque Assay

1. Seed Vero E6 cells in six-well plates at the density of 2 × 10⁶ cells per well.
2. Remove the medium after incubation for 18 h.
3. Make a serial tenfold dilution of each virus sample.

4. Infect cell monolayers with 400 μL of each tenfold dilution series of virus sample.
5. Incubate the plate at 37 °C for 1 h with constant shaking.
6. Prepare the overlay medium without agarose according to the following recipe (Table 3) and keep the prepared overlay medium in a 37 °C water bath.
7. Prepare 1 % agarose using the following recipe and boil it three times in microwave oven until agarose is totally dissolved. Keep the solution in 37 °C water bath.
8. Make complete overlay medium by mixing every 75 mL medium with 25 mL of 1 % agarose. Mix gently and keep the medium in 37 °C water bath until use.
9. Remove inoculum from each well.
10. Add 2 mL of overlay medium to each well.
11. Incubate the plates at 4 °C for 30 min to allow the overlay medium to solidify.
12. Transfer the plates to 37 °C and 5 % CO_2 to allow for plaque formation.
13. After incubation for 7 days, fix the cells by adding approximately 1 mL of 10 % (v/v) formaldehyde to each well and incubate for 2 h
14. Discard the overlay medium.
15. Stain the cells with 0.05 % (wt/vol) crystal violet, count the plaques, and calculate the virus titer.

3.8 *In Vitro trans* G-N-7 Methylation Assay for aMPV

1. Prepare confluent Vero-E6 cells in 150-mm dishes.
2. Infect Vero-E6 cells with wild-type aMPV or raMPV mutants at an MOI of 0.1 in the presence of actinomycin-D (0.6 $\mu\text{g}/\text{mL}$).
3. Isolate total RNA from virus-infected cells using TRIzol reagent (Life Technologies) when extensive CPE was observed and dissolve RNA in 10 mM Tris-HCl buffer (pH 7.5).
4. Isolate aMPV specific poly(A)-containing RNA from total RNA using a Dynabeads mRNA isolation kit (Life Technologies).
5. Quantify aMPV-specific mRNA (N mRNA) and cellular mRNA (glyceraldehyde-3-phosphate dehydrogenase [GAPDH] mRNA) by real-time RT-PCR.
6. Incubate 500 ng of mRNA (as determined by the relative quantification based on GAPDH RNAs) with ten units of vaccinia virus G-N-7 MTase supplied by an m⁷G capping system (Cellsript, Madison, WI) in the presence of 15 μCi of [³H] SAM (85 Ci/mmol; PerkinElmer, Wellesley, MA) for 4 h.
7. Purify RNA using an RNeasy Mini Kit (Qiagen, Valencia, CA) after the methylation reaction.

8. Measure the methylation of the mRNA cap structure by ^3H incorporation using a 1414 series scintillation counter (PerkinElmer).
9. The ^3H incorporation (in corrected counts per minute [ccpm]) from wild-type and mutant aMPV samples was reduced by the ccpm of RNA from mock-infected cells.
10. Normalize the ccpm by virus-specific mRNA. The ratio of [^3H]SAM incorporation between each mutant and wild-type virus was calculated. Vaccinia virus G-N-7 MTase will not methylate the mRNAs produced by wild-type aMPV since they already contain G-N-7 and 2'-O methylation. Vaccinia virus G-N-7 MTase should efficiently methylate the mRNA if mRNA produced by aMPV mutants lacks G-N-7 methylation.

3.9 *In Vitro trans* 2'-O Methylation Assay for aMPV

1. Purify mRNA in virus-infected cells as described in Subheading 3.8.
2. Isolate aMPV specific poly(A)-containing RNA from total RNA using a Dynabeads mRNA isolation kit (Life Technologies).
3. Incubate 500 ng of mRNAs with 10 units of vaccinia virus 2'-O MTase supplied by a vaccinia 2'-O-Methyltransferase Kit (Cellscript) in the presence of 15 μCi of [^3H]SAM (85 Ci/mmol; PerkinElmer).
4. Purify RNA using an RNeasy Mini Kit (Qiagen) after the methylation reaction.
5. Measure the level of 2'-O methylation by ^3H incorporation using a scintillation counter. The ^3H incorporation (in corrected counts per minute [ccpm]) from wild-type and mutant aMPV samples was reduced by the ccpm of RNA from mock-infected cells.
6. Normalize the ccpm by virus-specific mRNA. The ratio of [^3H]SAM incorporation between each mutant and wild-type virus was calculated. Vaccinia virus 2'-O MTase will not methylate the mRNAs produced by wild-type aMPV since they already contain G-N-7 and 2'-O methylation. Vaccinia virus 2'-O MTase should efficiently methylate the mRNA if mRNA produced by aMPV mutants lacks 2'-O methylation.

3.10 *Test Genetic* Stability of raMPV Mutants in Cell Culture

1. Pass each aMPV mutant in Vero-E6 cells 15 times.
2. Amplify the CR VI of the L gene from each passage by RT-PCR.
3. Amplify the genome of each aMPV mutant from each passage by RT-PCR using eight overlapping fragments (2 kb for each fragment).
4. Sequence all DNA fragments.
5. Align DNA sequence and analyze the presence of mutations in the DNA fragments.

6. A genetically stable raMPV mutant should retain its mutation in the CR VI of the L gene after 15 passages. Except for the desired mutation in the MTase region in the L gene, no mutations should be found in the genome.

3.11 Evaluate Replication and Pathogenesis of raMPV Mutants in Turkey Poults

1. Purchase 2-week-old specific pathogen-free (SPF) turkeys and house in biosafety level 2 isolation rooms.
2. Collect blood samples from each turkey and confirm they are serum-negative for aMPV antibody by enzyme-linked immunosorbent assay (ELISA).
3. Randomly allocate 12 turkeys to each group.
4. Inoculate each raMPV mutant to turkey poults. For negative control group, turkeys are inoculated with 200 μ L of DMEM via the oculonasal route. For positive control group, turkeys are infected with 2.0×10^5 PFU of wild-type raMPV. For raMPV mutant group, turkeys are infected with 200 μ L of DMEM containing 2.0×10^5 PFU of raMPV mutant.
5. Observe the animals daily for mortality and morbidity.
6. Euthanize three turkeys from each group at 3, 5, 7, and 10 days postinoculation (DPI). Collect sinus and trachea swabs and elute in 1 mL of DMEM for virus and viral RNA detection. Collect lungs and tracheas for virus isolation, viral RNA detection, and histological examination.
7. Analyze the replication and pathogenesis of each aMPV mutant using above method. These aMPV mutants include aMPV-G1696A, G1698A, G1700A, N1701A, and D1755A.
8. An attenuated aMPV mutant should exhibit the following phenotypes in young turkeys: no clinical signs (weight losses, cough, turbid nasal exudates, frothy eyes, and/or swollen infraorbital sinuses) of aMPV are observed; no or significantly less viral replication in the upper (trachea and sinus) and lower (lungs) respiratory tract of turkeys; no gross pathological lesions found in turkeys; and no or significantly less histologic lesions are found in trachea, sinus, and lung of turkeys.

3.12 Evaluate Genetic Stability of raMPV Mutants in Turkey Poults

1. Inoculate five 2-week-old specific pathogen-free (SPF) turkeys with MTase-defective aMPV at a dose of 1.0×10^6 PFU via the oculonasal route.
2. Euthanize the turkeys at days 3 postinoculation.
3. Isolate and homogenize lung tissue. Inoculate 200 μ L of lung homogenate into a T25 flask of Vero E6 cells.
4. Allow the virus to adsorb for 1 h with constant shaking at 37 °C.

5. Add 4 mL of Opti-MEM contains 2%FBS and incubate at 37 °C for 4 days.
6. Harvest supernatants and cells when extensive CPE is observed.
7. Clarify the cell suspension by low-speed centrifugation at $3000 \times g$ for 20 min at 4 °C and designate viral stock as passage 1 (P1).
8. Sequence the entire genome of aMPV from P1.
9. Determine viral titer in P1 stock by plaque assay.
10. Inoculate five 2-week-old specific pathogen-free (SPF) turkeys with P1 stock at a dose of 1.0×10^6 PFU via the oculonasal route and repeat **steps 1–10**.
11. Continue to pass the virus in turkeys five times using the above method.
12. Determine whether aMPV mutants are genetically stable in turkeys.
13. Analyze the genetic stability of each aMPV mutant using the above method. These aMPV mutants include aMPV-G1696A, G1698A, G1700A, N1701A, and D1755A.
14. A genetically stable aMPV mutant should exhibit the following phenotypes in turkeys: virus isolated from each passage should retain the desired the mutation in the L gene; no additional mutations should be found in the genome except for the desired mutation in the L gene; virus should retain attenuation characteristics in turkeys; and no virulence reversion should be found.

3.13 Determine the Immunogenicity of aMPV Mutants in Turkeys

1. House specific pathogen-free (SPF) turkeys in cages in bio-safety level II isolation rooms.
2. Randomly divide fifteen 2-week-old SPF turkey poults to each group.
3. Immunize turkeys with MTase-defective aMPVs. Turkeys in group 1 were inoculated with DMEM and served as the unimmunized unchallenged control (normal control). Turkeys in group 2 were inoculated with DMEM and served as the unimmunized but challenged control. Turkey poults in groups 3 were immunized with 2×10^5 PFU of an aMPV mutant. All inoculation was done via the oculonasal route.
4. Observe the safety of aMPV mutants in turkeys twice a day.
5. Collect blood samples from each turkey weekly.
6. Isolate serum from blood for detection of aMPV-specific antibody.
7. Challenge turkeys in groups 2 and 3 with wild-type raMPV at a dose of 1.0×10^6 PFU per turkey via the oculonasal route at week 4 post-immunization.

8. Observe animals twice a day for mortality and morbidity after challenge.
9. Euthanize three turkeys from each group at 3, 5, 7, and 10 days postinoculation (DPI). Collect sinus and trachea swabs and eluted in 1 mL of DMEM for detection of virus and viral RNA. Collect lungs and tracheas for virus isolation, viral RNA detection, and histologic analysis.
10. Determine viral titer in the sinus and trachea swabs and lungs by plaque assay.
11. Extract total RNA from sinus and trachea swabs and lungs.
12. Quantify viral genomic RNA by real-time RT-PCR.
13. Determine aMPV-specific antibody by a virus-serum neutralization assay using an end-point dilution plaque reduction assay.
14. Analyze the immunogenicity of each aMPV mutant using the above method. These aMPV mutants include aMPV-G1696A, G1698A, G1700A, N1701A, and D1755A.
15. An ideal aMPV live attenuated vaccine should exhibit the following phenotypes: aMPV mutant should trigger high levels of virus-serum neutralizing antibody in turkeys; raMPV mutant vaccination should protect turkeys from clinical signs after challenge with a virulent aMPV; raMPV mutant vaccination should protect turkeys from gross and histologic lesions in sinus, trachea, and lung after challenge with a virulent aMPV; and raMPV mutant vaccination should prevent or significantly reduce virus replication in sinus, trachea, and lung after challenge with a virulent aMPV.

3.14 Evaluate the Tracheal and Pulmonary Histologic Changes

1. Remove the trachea and right lung of each turkey at euthanization.
2. Fix the trachea and lung in 4 % neutral buffered formaldehyde for at least 7 days.
3. Embed the fixed tissues in paraffin and section at 5 μm .
4. Stain slides with hematoxylin and eosin (H&E).
5. Examine histologic changes of each tissue under light microscopy.

3.15 Determine aMPV Serum Neutralizing Antibody by Plaque Reduction Neutralizing Assay

1. Seed Vero E6 cells into six-well plates 24 h prior to assay.
2. Heat inactivate serum samples at 56 °C for 30 min.
3. Take 100 μL of each serum sample and make a serial twofold dilutions in DMEM on a 96-well plate.
4. Mix the serial dilution of serum samples with an equal volume of DMEM containing approximately 100 PFU/well wild-type aMPV.

5. Incubate the mixture at room temperature for 1 h with constant rotation.
6. Transfer the mixture to confluent Vero E6 cells in a six-well plate.
7. Incubate the plates at 37 °C for 1 h with constant rotation.
8. Remove the virus-serum mixtures after 1 h adsorption and overlay the cells with overlay medium.
9. Incubate the plate for 7 days to develop viral plaque.
10. Fix the plates and count plaques in each well.
11. Determine aMPV-specific neutralizing antibody titers by calculating the 50 % plaque reduction titers.

3.16 Determination of Viral Titer in Sinus and Trachea

1. Collect sinus and trachea swabs from each turkey.
2. Elute the swabs in 1 mL of DMEM by vortexing for 1 min.
3. Centrifuge the swab at 3000 ×g for 10 min.
4. Collect the supernatants for virus detection using plaque assay.

3.17 Determination of Viral Titer in Lung

1. Take the left lung from each turkey poult after euthanization.
2. Homogenize 200 mg of the lung tissue in 2 mL of phosphate-buffered saline (PBS) solution with a Precellys 24 tissue homogenizer (Bertin, MD).
3. Centrifuge the homogenate at 1000 ×g for 10 min and harvest supernatant.
4. Determine the infectious virus titer in supernatant by plaque assay in Vero cells as described above.

3.18 Reverse Transcription Polymerase Chain Reaction (RT-PCR) and Sequencing

1. Extract viral RNA from 200 µL of each recombinant virus or tissue homogenate using an RNeasy Mini Kit (Qiagen).
2. Design primers to anneal to nucleotide positions 12938 and 13464 (numbers are based on the genome sequence of aMPV-CO strain), respectively.
3. Amplify a 520 bp fragment spanning CR VI of aMPV L gene using One-Step RT-PCR kit (Qiagen).
4. Load the PCR products to 1 % agarose gel and electrophoresis at 100 V for 40 min.
5. Stain the gel in 0.5 µg/mL ethidium bromide for 20 min.
6. Visualize the PCR product under ultraviolet (UV) light and confirm the size of the PCR product.
7. Extract the target DNA band and recover the DNA using Gel purification kit (Qiagen).
8. Sequence the PCR product using aMPV-L-12938-Forward primer.

9. Sequence all plasmids, viral stocks, and virus isolates from sinus, trachea, and lungs of turkeys.
10. Confirm the presence of the designed mutations.

3.19 Quantification of Viral Genomic RNA by Real-Time RT-PCR

1. Extract total RNA from sinus, tracheal swabs, and lungs by Qiagen RNeasy Mini Kit (Qiagen) following the manufacturer's recommendation.
2. Extract total RNA from the homogenized lung tissue samples and sinus and tracheal swab fluids.
3. Quantify viral genomic RNA copies (GRC) from each sample by real-time RT-PCR using SYBR green master mix (Applied Biosystems). Set up reaction according to Table 4 using the thermal cycling parameters listed in Table 5. A plasmid containing the full-length genome of aMPV-CO was used as a standard. Viral RNA level in lungs was expressed as log GRC/g. Viral RNA levels in the sinus and tracheal swab fluid was expressed as log GRC/mL.

Table 4
Components for quantitative RT-PCR reaction

Component	Volume
Power SYBR green RT-PCR mix (2×)	10 µL
Forward primer (25 µM)	0.6 µL
Reverse primer (25 µM)	0.6 µL
RT-enzyme mix	0.16 µL
Template	0.01–20 ng
RNase-free H ₂ O	20 µL
Total	20 µL

Table 5
Thermal cycling parameters for quantitative RT-PCR

Stage	Step	Temperature (°C)	Time
Holding	Reverse transcription	48	30 min
Holding	Activation of polymerase	95	10 min
Cycling	Denature	95	15 s
	Anneal/extend	60	1 min

Acknowledgements

This study was supported by grants from the USDA NIFA Animal Health Program (2010-65119-20602) and the NIH (R01AI090060).

References

1. Broor S, Bharaj P (2007) Avian and human metapneumovirus. *Ann N Y Acad Sci* 1102:66–85
2. Easton AJ, Domachowske JB, Rosenberg HF (2004) Animal pneumoviruses: molecular genetics and pathogenesis. *Clin Microbiol Rev* 17:390–412
3. Hafez HM, Hess M, Prusas C, Naylor CJ, Cavanagh D (2000) Presence of avian pneumovirus type A in continental Europe during the 1980s. *J Vet Med B Infect Dis Vet Public Health* 47:629–633
4. Aung YH, Liman M, Neumann U, Rautenschlein S (2008) Reproducibility of swollen sinuses in broilers by experimental infection with avian metapneumovirus subtypes A and B of turkey origin and their comparative pathogenesis. *Avian Pathol* 37:65–74
5. Toquin D, Guionie O, Jestin V, Zwingelstein F, Allee C, Eterradossi N (2006) European and American subgroup C isolates of avian metapneumovirus belong to different genetic lineages. *Virus Genes* 32:97–103
6. Wei L, Zhu S, Yan X, Wang J, Zhang C, Liu S, She R, Hu F, Quan R, Liu J (2013) Avian metapneumovirus subgroup C infection in chickens, China. *Emerg Infect Dis* 19:1092–1094
7. Govindarajan D, Buchholz UJ, Samal SK (2006) Recovery of avian metapneumovirus subgroup C from cDNA: cross-recognition of avian and human metapneumovirus support proteins. *J Virol* 80:5790–5797
8. Turpin EA, Stallknecht DE, Slemons RD, Zsak L, Swayne DE (2008) Evidence of avian metapneumovirus subtype C infection of wild birds in Georgia, South Carolina, Arkansas and Ohio, USA. *Avian Pathol* 37:343–351
9. Goyal SM, Chiang SJ, Dar AM, Nagaraja KV, Shaw DP, Halvorson DA, Kapur V (2000) Isolation of avian pneumovirus from an outbreak of respiratory illness in Minnesota turkeys. *J Vet Diagn Invest* 12:166–168
10. Alkhalaf AN, Ward LA, Dearth RN, Saif YM (2002) Pathogenicity, transmissibility, and tissue distribution of avian pneumovirus in turkey poults. *Avian Dis* 46:650–659
11. Padhi A, Poss M (2009) Population dynamics and rates of molecular evolution of a recently emerged paramyxovirus, avian metapneumovirus subtype C. *J Virol* 83:2015–2019
12. Wei Y, Feng K, Yao X, Cai H, Li J, Mirza AM, Iorio RM (2012) Localization of a region in the fusion protein of avian metapneumovirus that modulates cell-cell fusion. *J Virol* 86:11800–11814
13. van den Hoogen BG, de Jong JC, Groen J, Kuiken T et al (2001) A newly discovered human pneumovirus isolated from young children with respiratory tract disease. *Nat Med* 7:719–724
14. van den Hoogen BG, Herfst S, Sprong L, Cane PA et al (2004) Antigenic and genetic variability of human metapneumoviruses. *Emerg Infect Dis* 10:658–666
15. Wei Y, Zhang Y, Cai H, Mirza AM, Iorio RM, Peeples ME, Niewiesk S, Li J (2014) Roles of the putative integrin-binding motif of the human metapneumovirus fusion (f) protein in cell-cell fusion, viral infectivity, and pathogenesis. *J Virol* 88:4338–4352
16. Velayudhan BT, Nagaraja KV, Thachil AJ, Shaw DP, Gray GC, Halvorson DA (2006) Human metapneumovirus in turkey poults. *Emerg Infect Dis* 12:1853–1859
17. Ganapathy K, Jones RC (2007) Vaccination of chicks with live attenuated subtype B avian metapneumovirus vaccines: protection against challenge and immune responses can be unrelated to vaccine dose. *Avian Dis* 51:733–737
18. Naylor CJ, Ling R, Edworthy N, Savage CE, Easton AJ (2007) Avian metapneumovirus SH gene end and G protein mutations influence the level of protection of live-vaccine candidates. *J Gen Virol* 88(Pt 6):1767–1775
19. Patnayak DP, Gulati BR, Sheikh AM, Goyal SM (2003) Cold adapted avian pneumovirus for use as live, attenuated vaccine in turkeys. *Vaccine* 21:1371–1374
20. Patnayak DP, Sheikh AM, Gulati BR, Goyal SM (2002) Experimental and field evaluation of a live vaccine against avian pneumovirus. *Avian Pathol* 31:377–382
21. Hu H, Roth JP, Estevez CN, Zsak L, Liu B, Yu Q (2011) Generation and evaluation of a recombinant Newcastle disease virus expressing

- the glycoprotein (G) of avian metapneumovirus subgroup C as a bivalent vaccine in turkeys. *Vaccine* 29:8624–8633
22. Lupini C, Cecchinato M, Ricchizzi E, Naylor CJ, Catelli E (2011) A turkey rhinotracheitis outbreak caused by the environmental spread of a vaccine-derived avian metapneumovirus. *Avian Pathol* 40:525–530
 23. Velayudhan BT, Noll SL, Thachil AJ, Shaw DP et al (2007) Development of a vaccine-challenge model for avian metapneumovirus subtype C in turkeys. *Vaccine* 25:1841–1847
 24. Whelan SP, Barr JN, Wertz GW (2004) Transcription and replication of nonsegmented negative-strand RNA viruses. *Curr Top Microbiol Immunol* 283:61–119
 25. Sun J, Wei Y, Rauf A, Zhang Y et al (2014) Methyltransferase-defective avian metapneumovirus vaccines provide complete protection against challenge with the homologous Colorado strain and the heterologous Minnesota strain. *J Virol* 88:12348–12363
 26. Zhang Y, Wei Y, Zhang X, Cai H, Niewiesk S, Li J (2014) Rational design of human metapneumovirus live attenuated vaccine candidates by inhibiting viral mRNA cap methyltransferase. *J Virol* 88:11411–11429
 27. Li J, Fontaine-Rodriguez EC, Whelan SP (2005) Amino acid residues within conserved domain VI of the vesicular stomatitis virus large polymerase protein essential for mRNA cap methyltransferase activity. *J Virol* 79:13373–13384
 28. Li J, Rahmeh A, Morelli M, Whelan SP (2008) A conserved motif in region v of the large polymerase proteins of nonsegmented negative-sense RNA viruses that is essential for mRNA capping. *J Virol* 82:775–784
 29. Li J, Wang JT, Whelan SP (2006) A unique strategy for mRNA cap methylation used by vesicular stomatitis virus. *Proc Natl Acad Sci U S A* 103:8493–8498
 30. Ma Y, Wei Y, Zhang X, Zhang Y et al (2014) mRNA cap methylation influences pathogenesis of vesicular stomatitis virus in vivo. *J Virol* 88:2913–2926

Development of Fasciola Vaccine in an Animal Model

Krai Meemon and Prasert Sobhon

1 Introduction

Fasciolosis (also called fascioliasis) is a zoonotic parasitic disease that is caused by the infection of trematodes *Fasciola hepatica* (*F. hepatica*) and *Fasciola gigantica* (*F. gigantica*), found in temperate and tropical regions, respectively. The disease causes reductions in the meat and milk production and decreased fertility in animals as well as afflicting the health of infected animals and humans. The World Health Organization (WHO) has estimated that 2.4 million people are infected with *Fasciola*, and a further 180 million are at risk of infection [1]. Triclabendazole is the most effective anthelmintic drug for controlling the disease [2]. However, resistance to this drug has been reported in many countries including Argentina [3], Australia [4], the Netherlands [5], and Scotland [6]. Vaccine becomes an alternative approach because of its safety, environmental friendliness, and cost-effectiveness and is acceptable by consumers [7]. Several vaccine candidates have been identified and tested for their efficacies against *Fasciola* infection in both experimental and economic animals. These include cathepsin B, cathepsin L, glutathione S-transferase, leucine aminopeptidase, and fatty acid-binding protein in *F. hepatica* [8–12] and cathepsin B, cathepsin L, glutathione S-transferase, leucine aminopeptidase, and saposin-like protein 2 in *F. gigantica* [13–17]. High percentages of protection have been detected using the recombinant protein immunizations suggesting that these could be developed into vaccines for preventing *Fasciola* infection in the future. A few DNA vaccines related to these candidates have also been shown to induce high levels of immune responses against the *Fasciola* infection [18–20], but they will not be described in this chapter.

In this chapter, optimized methods for vaccination using the recombinant proteins against *Fasciola* infection in mice are described. The production and purification of recombinant proteins in the yeast *Pichia pastoris* expression system are detailed. The detection of antibody levels is also described to determine the levels of IgG by ELISA technique.

2 Materials

2.1 Recombinant Protein Production in the Yeast *Pichia pastoris* Expression System

1. pPICZ α A, B, C vectors (Invitrogen).
2. Selected restriction enzymes and appropriate 10 \times buffers.
3. Gel documentation system.
4. QIAquick gel extraction kit (QIAGEN).
5. 0.2 mL thin-walled PCR tube.
6. T4 DNA ligase and ligation buffer.
7. 16 and 42 °C water baths or temperature blocks.
8. *E. coli* (DH5 α) competent cells.
9. ZeocinTM.
10. Low-salt LB broth containing 50 μ g/mL ZeocinTM: To 1 L of distilled H₂O, add 10 g tryptone, 5 g yeast extract, and 5 g NaCl. Mix thoroughly and sterilize by autoclaving. Cool the solution to approximately 60 °C; add ZeocinTM to the final concentration of 50 μ g/mL ZeocinTM.
11. LB agar plate containing 50 μ g/mL ZeocinTM: To 1 L of distilled H₂O, add 10 g tryptone, 5 g yeast extract, 5 g NaCl, and 15 g Agar. Mix thoroughly and sterilize by autoclaving. Cool the solution to approximately 60 °C; add ZeocinTM to the final concentration of 50 μ g/mL ZeocinTM. Then pour the solution onto bacterial culture plates.
12. Thermal cycler for PCR reaction.
13. Quick Plasmid Miniprep Kit (Invitrogen).
14. *Bst*X I restriction enzymes and appropriate 10 \times buffers.
15. Agarose gel electrophoresis.
16. *Pichia pastoris* (*P. pastoris*) host strain (e.g., X-33, GS115) competent cells.
17. Electroporation device and 0.2 cm cuvettes.
18. 30 and 37 °C shaking and non-shaking incubators.
19. Yeast extract peptone dextrose medium with sorbitol (YPDS) agar plate: 1 % yeast extract, 2 % peptone, 2 % dextrose, 1 M sorbitol, and 2 % agar.

20. Minimal dextrose medium (MD) agar plate: 1.34 % yeast nitrogen base, 2 % dextrose, 4×10^{-5} % biotin, and 1.5 % agar.
21. Minimal methanol medium (MM) agar plate: 1.34 % yeast nitrogen base, 0.5 % methanol, and 4×10^{-5} % biotin and 1.5 % agar.

2.2 Expression and Purification of the Recombinant Proteins

1. Buffered glycerol-complex medium (BMGY): 2 % peptone, 1 % yeast extract, 100 mM potassium phosphate (K_2HPO_4), pH 6.0, 1.34 % yeast nitrogen base, 4×10^{-5} % biotin, and 1 % glycerol.
2. Buffered methanol-complex medium (BMMY): 2 % peptone, 1 % yeast extract, 100 mM potassium phosphate, pH 6.0, 1.34 % yeast nitrogen base, 4×10^5 % biotin, and 0.5 % methanol.
3. Ni-NTA starter buffer: 50 mM NaH_2PO_4 , 300 mM NaCl, 10 mM imidazole, pH 8.0.
4. Ni-NTA washing buffer: 50 mM NaH_2PO_4 , 300 mM NaCl, 20 mM imidazole, pH 8.0.
5. Ni-NTA super-flow column (QIAGEN).
6. Ni-NTA elution buffer: 50 mM NaH_2PO_4 , 300 mM NaCl, 250 mM imidazole, pH 8.0.
7. SDS-PAGE analysis.
8. 0.01 M phosphate-buffered saline (PBS): To 900 mL of distilled H_2O , add 8 g NaCl, 0.2 g KCl, 1.44 g Na_2HPO_4 , and 0.24 g KH_2PO_4 . Adjust to 1 L with distilled H_2O and sterilize by autoclaving.
9. Protein assay kit (Bio-Rad) or equivalent.

2.3 Vaccination Procedure

2.3.1 Animal Model

1. Imprinting control region (ICR) mice: 10 mice per group.
2. Mice are divided into control and experimental groups.
3. Control groups are subdivided into control 1, mice without immunization and infection; control 2, mice without immunization, but with infection; control 3, mice with immunization with Freund's adjuvant and infection.
4. Experimental groups are mice that are immunized with the recombinant proteins either alone or in combination with other proteins.

2.3.2 Vaccination

1. Heparinized capillary glass tubes.
2. Hematocrit centrifuge (BOEC, Germany).
3. 0.9 and 0.85 % NaCl solution.
4. Complete and incomplete Freund's adjuvants.
5. 23 gauge \times 1" needle.
6. 18 gauge, oral gavage needle.

2.4 Worm Recovery

1. Petri dish.
2. Surgical and dissecting instrument.
3. Stereomicroscope.

2.5 Detection of Antibody Levels

1. 96-well microtiter plate.
2. 0.05 M carbonate-bicarbonate buffer, pH 9.6: 15 mM Na_2CO_3 , 35 mM NaHCO_3 , pH 9.6.
3. 0.01 M phosphate-buffered saline (PBS): To 900 mL of distilled H_2O , add 8 g NaCl, 0.2 g KCl, 1.44 g Na_2HPO_4 , and 0.24 g KH_2PO_4 . Adjust to 1 L with distilled H_2O and sterilized by autoclaving.
4. Tween 20.
5. Skimmed milk.
6. HRP-conjugated goat anti-mouse IgG1 or IgG2a (SouthernBiotech, USA).
7. Dimethyl sulfoxide (DMSO).
8. 0.05 M phosphate-citrate buffer, pH 5.0: To 100 mL of H_2O , add 25.7 mL of 0.2 M dibasic sodium phosphate, 24.3 mL of 0.1 M citric acid, and 50 mL distilled H_2O .
9. 30 % H_2O_2 .
10. 3, 3', 5, 5'-Tetramethylbenzidine (TMB; Sigma, USA).
11. TMB substrate solution: Dissolve one TMB tablet in 1 mL of DMSO; add 9 mL of 0.05 M phosphate-citrate buffer, pH 5.0. Add 2 μL of fresh 30 % H_2O_2 per 10 mL of substrate buffer solution immediately prior to use.
12. 2 M H_2SO_4 .
13. An automatic Titertek Multiscan spectrophotometer (Flow Laboratories, USA) or equivalent.

3 Methods**3.1 Recombinant Protein Production in the Yeast *Pichia pastoris* Expression System**

1. Digest the plasmids containing the genes of interest with the specific restriction enzymes for subcloning into pPICZ α vector (*see Note 1*).
2. Digest pPICZ α vectors with the same restriction enzymes in 10 \times buffer.
3. Purify the digested genes of interest and pPICZ α vectors by using QIAquick gel extraction kit.
4. Ligate the purified digested products and pPICZ α vectors in 0.2 mL thin-walled PCR tube by using T4 DNA ligase enzyme and incubating at 16 °C for overnight.

5. Transform the ligated product of the recombinant plasmids into *E. coli* (DH5 α) competent cells by heat shock at 42 °C for 2 min.
6. Spread the mixture on low-salt LB agar plate containing 50 μ g/mL Zeocin™ and incubate at 37 °C for overnight.
7. Determine the positive clone of each single isolated colony by using colony PCR and DNA sequencing to check for correct open reading frame (ORF) of the recombinant plasmids.
8. Transfer the positive single colony to culture in 5 mL of low-salt LB broth containing 50 μ g/mL Zeocin™ at 37 °C, 200–250 rpm for overnight.
9. Purify the recombinant plasmids from the culture by using Quick Plasmid Miniprep Kit (Invitrogen).
10. Linearize the purified recombinant plasmids by digesting with *Bst*X I restriction endonucleases at the 5' *AOX1* region of pPICZ α vector.
11. Analyze the linearized recombinant plasmids on agarose gels and purify them from the gels by using QIAquick gel extraction kit.
12. Transform 5–10 μ g of linearized recombinant plasmids into 80 μ L of *P. pastoris* competent cells by electroporation.
13. Transfer and spread the mixture on YPDS plate containing 50 μ g/mL Zeocin™ and incubate at 30 °C for 3–10 days until colonies are formed.
14. Pick up the Zeocin™-resistant transformants and grow them on MM and MD agar plates at 30 °C for 3 days. The Mut⁺ strains will grow normally on both plates.
15. Set up the colony PCR reaction of the Mut⁺ strains to confirm the correct recombinant products by using 5'AOX1 (5'-GACTGGTTCCAATTGACAAGC-3') and 3'AOX1 (5'-GCAAATGGCATTCTGACATCC-3') primers.

3.2 Expression and Purification of the Recombinant Proteins

1. Inoculate a single positive colony into 25 mL of BMGY in 250 mL baffled flask.
2. Incubate with shaking at 30 °C, 250–300 rpm for 16–18 h.
3. Harvest the cells by centrifugation at 1500–3000 $\times g$ for 5 min at room temperature.
4. Resuspend the cell pellets in BMMY to an OD₆₀₀ = 1 and final volume for 500 mL in a 2 L baffled flask.
5. Cover the flask with 4–6 layers of sterile gauze.
6. Continue incubating the culture at 30 °C, 250–300 rpm.
7. Add 100 % methanol to each flask to a final concentration of 0.5 % methanol every 24 h to maintain the expression induction.

8. Collect 1 mL of the expression culture at 0, 24, 48, and 72 h to determine the levels of protein expression by sodium dodecyl sulfate-polyacrylamide gel electrophoresis (SDS-PAGE) analysis.
9. When the optimal time for expression is determined, large-scale expression can be performed by scaling up the culture volume of expression to 1 L of BMGY in a 3 or 4 L baffled flask and grow the culture with shaking at 30 °C, 250–300 rpm for 16–18 h following the above protocol.
10. Harvest the cells by centrifugation at 1500–3000 × *g* for 5 min at room temperature and resuspend the cell pellets in BMMY to an OD₆₀₀ = 1 with final volume of 2–6 L.
11. Harvest the culture by centrifugation at 1500–3000 × *g* for 5 min at room temperature.
12. Cover the flask with 4–6 layers of sterile gauze and continue incubating the culture at 30 °C, 250–300 rpm.
13. Add 100 % methanol to each flask to a final concentration of 0.5 % methanol every 24 h.
14. Dialyze the supernatants against Ni-NTA starter buffer (1:4) at cold temperature (4 °C).
15. Change the buffer every 4 h during dialysis.
16. Load the dialyzed supernatant onto the pre-equilibrated Ni-NTA super-flow column (QIAGEN).
17. Remove the unbound materials from the column by washing with the Ni-NTA washing buffer.
18. Elute the recombinant proteins with Ni-NTA elution buffer and analyzed them by SDS-PAGE.
19. Repeat the dialysis of all purified fractions with 0.01 M PBS at 4 °C for three times, for 4 h each.
20. Precipitate the recombinant proteins by centrifugation at 10,000 × *g* for 30 min at 4 °C.
21. Determine the concentration of the recombinant proteins by Lowry's method using Bio-Rad reagents and bovine serum albumin as standard (*see Note 2*).

3.3 Vaccination Procedure

1. An overview of the vaccination protocol is shown in Fig. 1.
2. At 4–5 days before immunization, collect the blood from all mice into heparinized capillary glass tubes by tail clipping.
3. Centrifuge the capillary tubes by using the hematocrit centrifuge and collect the pre-immune control sera.
4. At the day of immunization, mix thoroughly 50 µg of the purified recombinant protein diluted in 50 µL of 0.9 % NaCl solution with 50 µL of complete Freund's adjuvant until it becomes stable emulsion (*see Notes 3 and 4*).

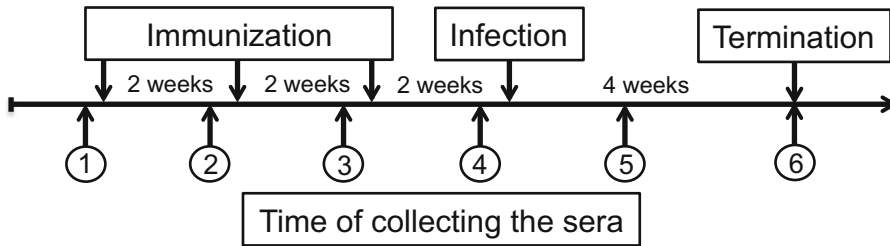

Fig. 1 Diagram of vaccination protocol. Mice should be immunized three times at 2-week interval and should be infected with 10–15 metacercariae per mouse at 2 weeks after the last immunization. Blood should be collected before immunization, at day 10 after each immunization and infection, and at the termination date as indicated (1–6)

5. Inject the emulsion subcutaneously into the loose skin between the shoulder blades of a mouse (*see Note 5*).
6. At day 10 after the immunization, collect the blood from all mice into heparinized capillary glass tubes by tail clipping.
7. Centrifuge the capillary tubes by using the hematocrit centrifuge and collect the immune sera.
8. At the second and third immunizations, mix thoroughly 50 μg of the purified recombinant protein diluted in 50 μL of 0.9 % NaCl solution with 50 μL of incomplete Freund's adjuvant. Prepare the emulsion freshly for each immunization.
9. Inject the emulsion subcutaneously into the loose skin as described above.
10. At day 10 after each immunization, collect the blood and sera from all mice as described above.
11. At 2 weeks after the third immunization, mice will be orally infected with 10–15 metacercariae per mouse by using 18 gauge, gavage needle (*see Notes 6 and 7*).
12. At day 10 or 2 weeks after infection, collect the blood and sera from all mice.
13. Mice will be kept in suitable condition for up to 4 weeks after infection.

3.4 Worm Recovery

1. At 4 weeks after infection, euthanize the mice by using an overdose of anesthetic or ether.
2. Collect the blood directly from the heart of mice by the heart puncturing.
3. Use the sterile scissor to open the peritoneal cavity and wash thoroughly with 0.85 % NaCl solution and collect the fluids into the petri dish to examine and count the worms.
4. Remove the liver and place onto the petri dish containing 0.85 % NaCl solution.

5. Dissect the liver and examine the worms under stereomicroscope (*see Note 8*).
6. Number of worms collected from each group will be used to calculate the percentage of protection by using the formula below:

$$\% \text{ Protection} = (A - B) / A \times 100$$

where “A” represents the mean worm recovery from the control group (the nonimmunized and infected group or the adjuvant-immunized and infected group) and “B” represents the mean worm recovery from the recombinant protein-immunized and infected group.

3.5 Detection of Antibody Levels

1. Coat the 96-well microtiter plate with 100 μL of 0.05 M carbonate-bicarbonate buffer, pH 9.6, containing 2 $\mu\text{g}/\text{mL}$ of the recombinant proteins by incubation overnight at 4 $^{\circ}\text{C}$.
2. Wash the wells with 0.01 M PBS containing 0.05 % Tween 20 (PBST), three times for 5 min each.
3. Add PBST containing 3 % skimmed milk to the wells and incubate at 37 $^{\circ}\text{C}$ for 2 h to block the nonspecific binding (*see Note 9*).
4. Wash the wells with PBST three times for 5 min each.
5. Add 100 μL of the antisera diluted with 0.01 M PBS containing 1 % skimmed milk (dilution at 1:50,000) to each well and incubate at 37 $^{\circ}\text{C}$ for 2 h (*see Note 10*).
6. Wash with PBST three times for 5 min each.
7. Add 100 μL of HRP-conjugated goat anti-mouse IgG1 or IgG2a (SouthernBiotech, USA) diluted in 0.01 M PBS containing 1 % skimmed milk (dilution at 1:5000) to each well and incubate at 37 $^{\circ}\text{C}$ for 1 h (*see Note 10*).
8. Wash the wells with PBST three times for 5 min each.
9. Add 100 μL of 3, 3', 5, 5'-tetramethylbenzidine (TMB; Sigma, USA) substrate solution to each well and incubate at room temperature for 5–10 min in the dark.
10. Add 50 μL of 2 M H_2SO_4 into the well to stop the enzymatic reaction.
11. Measure the optical density at 450 nm (OD_{450}) in an automatic Titertek Multiscan spectrophotometer (Flow Laboratories, USA).

4 Notes

1. pPICZ α A, B, C vectors have different multiple cloning sites for inserting the gene of interest into the vector. Plan this prior to selecting the appropriate vector for the protein expression.

2. Before determining the recombinant protein concentration, the proteins should be concentrated by using Amicon Ultra Centrifugal Devices, 3000 NMWL, 15 mL (Millipore Corporation, USA).
3. Mix the proteins thoroughly with Freund's adjuvant until they are completely dissolved and become stable emulsions. After injection into the mice, the proteins will be slowly released from the emulsions and continuously stimulate the host immune responses, so that more stable and higher immune responses will be achieved.
4. Many adjuvants are available to use for the recombinant protein vaccination. Selecting an appropriate adjuvant for each protein is also a subject of considerable concern.
5. Injection of the recombinant proteins can be done via any routes, e.g., intramuscular, intraperitoneal, intradermal, and subcutaneous, which may provide varying results. Different proteins may prefer different routes of vaccination and generate various degrees of effectiveness. The set of experiments relating to the routes of vaccination can be done prior to determine the optimal routes of injection.
6. In this experiment, three times of immunization are recommended. However, if the antibody is slowly increased and could not reach a desire level of immune responses, the forth immunization can be performed.
7. Before the experimental mice are infected by metacercariae, the viability and infectability of metacercariae can be determined by in vitro excystment [21, 22]. A number of metacercariae that are used to infect the experimental mice can be varied depending on their viability and infectability.
8. To examine the worms, incubate the petri dish for up to 4–5 h to let the worms migrate out from the dissecting liver, and check the worms regularly every 30 min during incubation.
9. To block the nonspecific binding in ELISA, 1 % bovine serum albumin can be used instead of skimmed milk.
10. Dilution of the anti-recombinant protein antisera or the HRP-conjugated goat anti-mouse IgG used in ELISA can be determined by varying dilutions of the antibodies prior to obtain the optimal values. Determination of the anti-recombinant protein antisera is recommended, while for the HRP-conjugated goat anti-mouse IgG the provided dilution value is an optimal.
11. The sera from mice in each group can be used to determine the degree of liver damage after vaccination. The levels of the liver enzymes, i.e., aspartate aminotransferase (AST) and alanine transaminase (ALT) for determining the liver parenchyma damage [23, 24] and gamma glutamyl transferase (GGT) which is indicative of the bile duct damage [25], will be mea-

sured in triplicate by using an automatic chemistry analyzer (Cobas Mira, Roche, Switzerland).

12. The correlations between the OD₄₅₀ values representing the levels of IgG1 and IgG2a in mice sera in each group and the numbers of recovery worms can be determined and analyzed statistically.

Acknowledgement

This article was supported by grants from Thailand Research Fund, Agricultural Research Development Agency (Public Organization), and Faculty of Science, Mahidol University.

References

1. Report of a WHO Study Group (1995) Control of foodborne trematode infections. World Health Organization Technical Report Series. 849:1–157
2. Fairweather I, Boray JC (1999) Fasciolicides: efficacy, actions, resistance and its management. *Vet J* 158:81–112
3. Olachea F, Lovera V, Larroza M, Raffo F, Cabrera R (2011) Resistance of *Fasciola hepatica* against triclabendazole in cattle in Patagonia (Argentina). *Vet Parasitol* 178:364–366
4. Overend DJ, Bowen FL (1995) Resistance of *Fasciola hepatica* to triclabendazole. *Aust Vet J* 72:275–276
5. Moll L, Gaasenbeek CP, Vellema P, Borgsteede FH (2000) Resistance of *Fasciola hepatica* against triclabendazole in cattle and sheep in The Netherlands. *Vet Parasitol* 91:153–158
6. Mitchell GB, Maris L, Bonniwell MA (1998) Triclabendazole-resistant liver fluke in Scottish sheep. *Vet Rec* 143:399
7. Dalton JP, Mulcahy G (2001) Parasite vaccines – a reality? *Vet Parasitol* 98:149–167
8. Dalton JP, McGonigle S, Rolph TP, Andrews SJ (1996) Induction of protective immunity in cattle against infection with *Fasciola hepatica* by vaccination with cathepsin L proteinases and with hemoglobin. *Infect Immun* 64:5066–5074
9. Morrison CA, Colin T, Sexton JL, Bowen F, Wicker J, Friedel T et al (1996) Protection of cattle against *Fasciola hepatica* infection by vaccination with glutathione S-transferase. *Vaccine* 14:1603–1612
10. Muro A, Ramajo V, Lopez J, Simon F, Hillyer GV (1997) *Fasciola hepatica*: vaccination of rabbits with native and recombinant antigens related to fatty acid binding proteins. *Vet Parasitol* 69:219–229
11. Piacenza L, Acosta D, Basmadjian I, Dalton JP, Carmona C (1999) Vaccination with cathepsin L proteinases and with leucine aminopeptidase induces high levels of protection against fascioliasis in sheep. *Infect Immun* 67:1954–1961
12. Jayaraj R, Piedrafita D, Dynon K, Grams R, Spithill TW, Smooker PM (2009) Vaccination against fasciolosis by a multivalent vaccine of stage-specific antigens. *Vet Parasitol* 160:230–236
13. Preyavichyapugdee N, Sahaphong S, Riengrojpitak S, Grams R, Viyanant V, Sobhon P (2008) *Fasciola gigantica* and *Schistosoma mansoni*: vaccine potential of recombinant glutathione S-transferase (rFgGST26) against infections in mice. *Exp Parasitol* 119:229–237
14. Changklungmoa N, Kueakhai P, Riengrojpitak S, Chaithirayanon K, Chaichanasak P, Preyavichyapugdee N et al (2013) Immunization with recombinant leucine aminopeptidase showed protection against *Fasciola gigantica* in mice. *Parasitol Res* 112:3653–3659
15. Chantree P, Phatsara M, Meemon K, Chaichanasak P, Changklungmoa N, Kueakhai P et al (2013) Vaccine potential of recombinant cathepsin B against *Fasciola gigantica*. *Exp Parasitol* 135:102–109
16. Kueakhai P, Changklungmoa N, Riengrojpitak S, Chaichanasak P, Meemon K, Chaithirayanon K et al (2013) Vaccine potential of recombinant saposin-like protein 2 against *Fasciolosis* *gigantica* in mice. *Vaccine* 31:5518–5523

17. Sansri V, Meemon K, Changklungmoa N, Kueakhai P, Chantree P, Chaichanasak P et al (2015) Protection against *Fasciola gigantica* infection in mice by vaccination with recombinant juvenile-specific cathepsin L. *Vaccine* 33:1596–1601
18. Smooker PM, Kennedy NJ, Steeper KR, Christopoulos H, Spithill TW (2001) *Fasciola*: kinetics and quality of humoral responses to fatty acid binding protein and cathepsin L following delivery as DNA vaccines in mice. *Exp Parasitol* 97:154–160
19. Espino AM, Osuna A, Gil R, Hillyer GV (2005) *Fasciola hepatica*: humoral and cytokine responses to a member of the saposin-like protein family following delivery as a DNA vaccine in mice. *Exp Parasitol* 110:374–383
20. Jayaraj R, Piedrafita D, Spithill T, Smooker P (2012) Evaluation of the immune responses induced by four targeted DNA vaccines encoding the juvenile liver fluke antigen, cathepsin B in a mouse model. *Genet Vaccines Ther* 10:7
21. Meemon K, Grams R, Vichasri-Grams S, Hofmann A, Korge G, Viyanant V et al (2004) Molecular cloning and analysis of stage and tissue-specific expression of cathepsin B encoding genes from *Fasciola gigantica*. *Mol Biochem Parasitol* 136:1–10
22. Sethadavit M, Meemon K, Jardim A, Spithill TW, Sobhon P (2009) Identification, expression and immunolocalization of cathepsin B3, a stage-specific antigen expressed by juvenile *Fasciola gigantica*. *Acta Trop* 112:164–173
23. Edith R, Godara R, Sharma RL, Thilagar MB (2010) Serum enzyme and hematological profile of *Fasciola gigantica* immunized and experimentally infected riverine buffaloes. *Parasitol Res* 106:947–956
24. Sandeman RM, Howell MJ (1981) Response of sheep to challenge infection with *Fasciola hepatica*. *Res Vet Sci* 30:294–297
25. Ford EJ (1974) Activity of gamma-glutamyl transpeptidase and other enzymes in the serum of sheep with liver or kidney damage. *J Comp Pathol* 84:231–243

Development of Experimental Vaccines Against Liver Flukes

Huan Yong Yap and Peter M. Smooker

1 Introduction

Fasciolosis is a disease caused by the Fasciola genus where *Fasciola hepatica* and *Fasciola gigantica* are predominantly found in temperate and tropical climates, respectively. Fasciolosis is traditionally regarded as a disease that affects ruminants which causes large economic losses in the agriculture sector, previously estimated at US\$ three billion annually [1], but likely to be far higher currently. In the last 20 years, it has also emerged as an important human zoonosis with an estimated 2.4 million people infected worldwide [2, 3]. In addition, cases of resistance to the drug of choice against fasciolosis, triclabendazole, have been reported in farms of many countries in Europe and in Australia [4–6]. The emergence of triclabendazole-resistant flukes has urged the discoveries of new alternatives to control fasciolosis.

Liver flukes sophisticatedly manipulate the host immune system to maintain their long term survival in the host by shifting the host immune response towards Th2-type, which is anti-inflammatory and promotes wound healing [7–9]. Th1 and Th2-type associated responses in the murine system are reflected by IgG2a and IgG1 isotypes, respectively [10]. The possible requirement of a Th1-type immune response to resist liver fluke infections has been demonstrated in sheep and cattle as IgG2 antibody levels were associated with lower liver flukes recoveries [11, 12]. However, all is not as simple as it seems, as in another study, low levels of IgG2 in sheep were seen as protective [13].

Previously, the efficacy of multivalent vaccines created by combining different cathepsin proteases, DNA vaccines constructed with cathepsin protease encoding genes, and single protein vaccines

with various excretory/secretory products as targeted antigens have been evaluated in different studies [14–18]. A protein vaccine with leucine amino peptidase (LAP) as a targeted antigen in alum adjuvant is the only vaccine that fulfilled the requirement to be a commercial vaccine as it appears to have efficacy that has reached the required level and the antigen is delivered in a commercially acceptable adjuvant [14, 19, 20]. Interestingly, the proposed protective pro-inflammatory immune responses induced by this vaccine are low, as indicated by a high IgG1/IgG2 ratio [20]. This would indicate that depending on the antigen, Th2 responses may also be protective.

Parasites secrete various proteases at different stages of their life cycle to facilitate parasitism and maintain their long term survival in the host. In *F. hepatica*, cathepsin B protease is expressed in the infectious metacercariae and in newly excysted juveniles while cathepsin L isoforms are secreted throughout the life cycle of liver flukes, and more than 80 % of proteins secreted by adult flukes are cathepsin Ls [21, 22]. Therefore, cathepsin proteases play a salient role in *F. hepatica* parasitism throughout the whole life cycle and could be a potential vaccine candidate, although the cleavage specificity of each cathepsin protease is not fully understood as yet. However, it has been shown that in adult fluke, three cathepsin proteases are secreted being L1, L2, and L5. While they have largely overlapping digestion patterns on most host substrates, L2 can completely cleave collagen, and L5 has a likely specific (but as yet undefined) target [23–26]. This article will focus on using cathepsin proteases as vaccine targets.

In nature, liver flukes produce cathepsin proteases as inactive zymogens initially. Upon secretion into the slightly acidic parasite gut, the acidic environment facilitates the cleavage of the prosegments and produces functionally active matured cathepsin proteases [27, 28]. All secreted cathepsin proteases in liver fluke have multiple disulfide bonds. If recombinant proteins are expressed in either the *E. coli* or yeast cytoplasm the disulfide bonds will not form, and the enzyme will be inactive [18, 29]. For this reason, the secretory pathway of yeast is used. Recombinant cathepsin protease is secreted by yeast into the culture media in an inactive form and can be activated in vitro by mixing in a buffer with pH range 5–6. The experimental recombinant protein vaccine development steps for fasciolosis are illustrated in Fig. 1.

Yeast expression systems bear the advantages of being unicellular and eukaryotic organisms as they are easy to grow, convenient for genetic manipulation and also with the capability for protein processing, together with the absence of endotoxin and oncogenic or viral DNA. As mentioned above, the expression of eukaryotic protein using prokaryotic system sometimes results in an inactive product due to incorrect folding or certain posttranslational

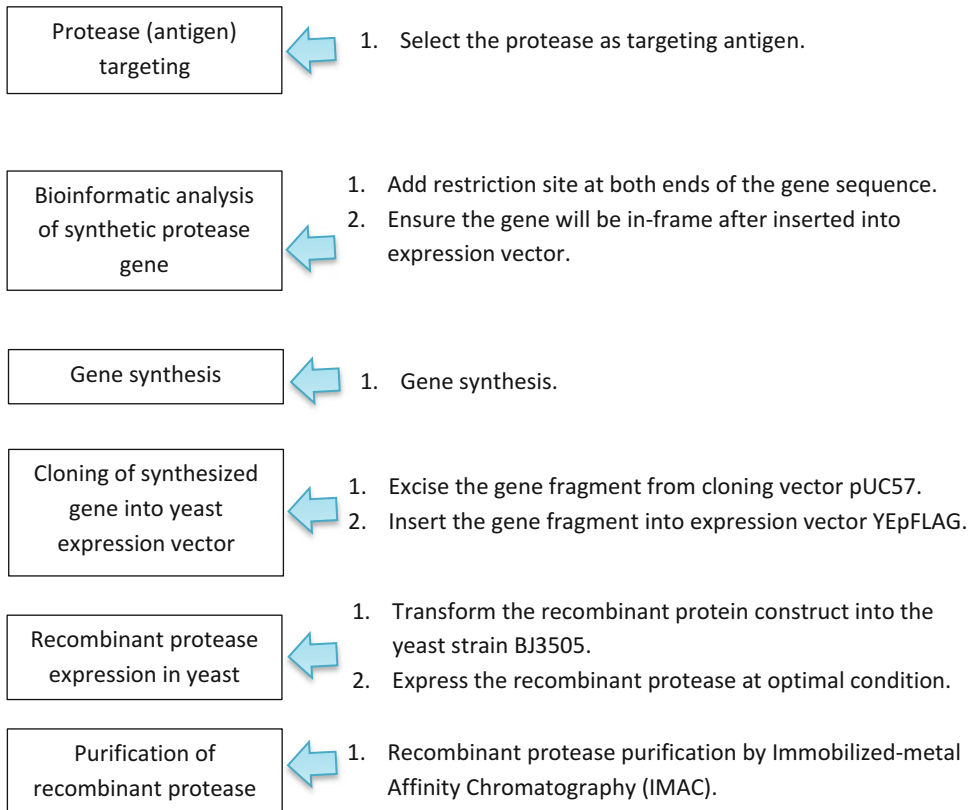

Fig. 1 Flowchart of experimental recombinant protein vaccine development steps for fasciolosis

modifications that are missed [30]. Hence, a yeast expression vector is the system of choice to express cathepsin proteases to ensure the activity and the integrity of the recombinant enzymes.

The ability of DNA vaccines to induce both humoral and cellular immune responses that can be manipulated by one of several delivery methods, either to the skin or subcutaneum or muscle, is well known [31]. While the effectiveness of the DNA vaccine in large animals has often been disappointing [32], one of the four licensed DNA vaccines for animal use is against West Nile virus in horses [33]. Furthermore, the route of immunization [29], the species being immunized [32] and the composition of the antigen [34, 35] should be considered as they are also crucial in determining the effectiveness of a vaccine to elicit a protective immune response.

The choice of vectors for DNA vaccines depends on the strategy and the objectives of the study. There are several vectors that were used in previous studies to deliver the antigen to the different cellular types and location in the body of the vaccinated host.

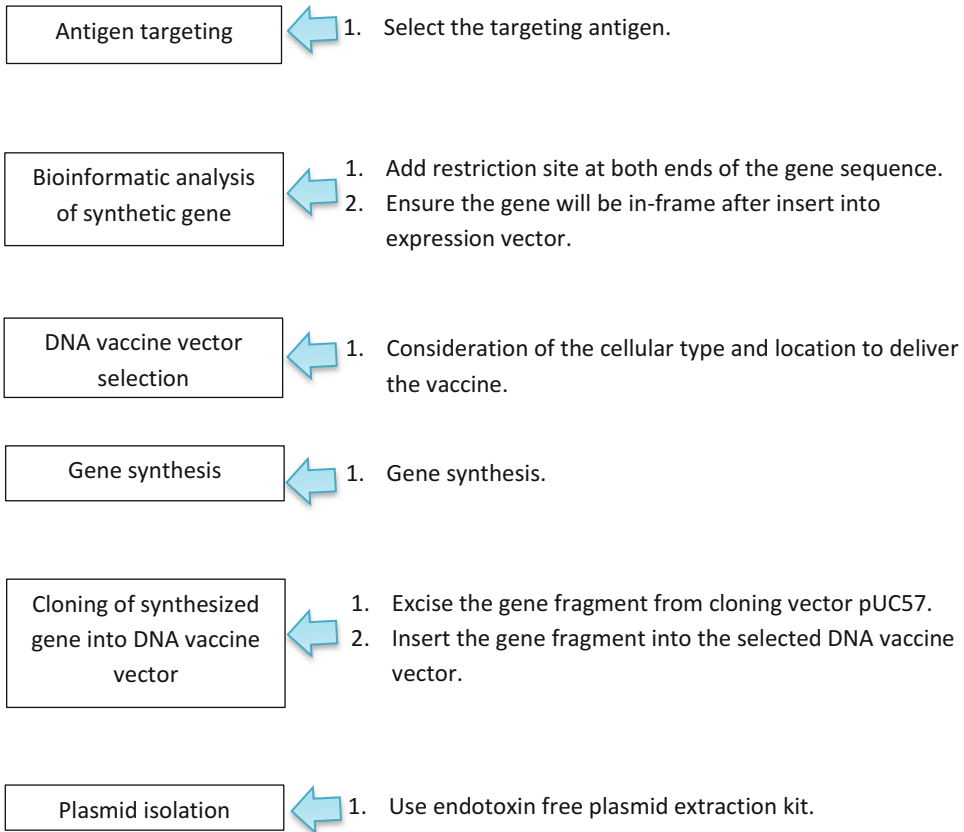

Fig. 2 Flowchart of experimental DNA vaccine development steps for fasciolosis

Examples are cytoplasmic construct pVR1012, secretory construct pVR1020, chemokine-fused construct pMCP3, lymph node targeting construct pCTLA-4, cytoplasmic pMASIA, and CpG motifs-containing cytoplasmic pBISIA-40 [16, 18, 29]. The experimental DNA vaccine development steps for fasciolosis are illustrated in Fig. 2.

As fasciolosis is predominately a disease of ruminants, it is clear that experimental vaccine studies are preferably undertaken in one of sheep, goats, cattle, or buffalo. The choice of which definitive host is used will largely depend on the parasite species and the predominant region for which the vaccine is a target. Hence, we have previously undertaken vaccine trials in cattle in Indonesia, where *F. gigantica* is the relevant parasite, and infects large numbers of cattle [36]. In other regions, for example South American countries, sheep are predominately infected and are therefore used as the experimental animals [14].

Having said this, experiments in large animals are expensive, and therefore are often preceded by experiments in commonly

used laboratory animals such as mice, rats, and rabbits. While the immune responses to *Fasciola* in these animals may not mimic those in larger animals, some information regarding the potential effectiveness of vaccine antigen can be gained. As an example, we have used a rat model to test a set of three antigens, together and in combination [37]. The rat model is a perfectly reasonable alternative to ruminants for comparing efficacy between groups.

2 Materials

2.1 Protein Vaccine

2.1.1 Bio-informatics Analysis and Synthesis of Cathepsin Protease Genes

1. Extract nucleotide sequence from GenBank, NCBI.
2. Expasy translation tool.
3. Analyze with codon optimization program.

2.1.2 Cloning of Cathepsin Protease Genes into Expression Vector

1. Synthetic gene in pUC57 cloning vector.
2. YE

FLAG

 expression vector.
3. *S. cerevisiae* strain BJ3505 for recombinant protease expression.
4. Restriction enzymes: XhoI, NotI, and 10× buffers.
5. Agarose, loading dye, nucleic acid stain suitable for gel electrophoresis and 1× TAE buffer for running gel electrophoresis.
6. Agarose gel electrophoresis system: for 50 mL of 1.5 % agarose gel, use 0.75 g of ultrapure agarose powder with 50 mL of 1× TAE buffer. Prepare 1 L of 10× TAE stock buffer in Milli-Q water with 48.4 g of Tris base, 3.72 g di-sodium EDTA, adjust to pH 8.5 with glacial acetic acid and dilute to 1× TAE solution prior to use.
7. Gel documentation system.
8. ISOLATE II PCR and Gel Kit (Bioline) for gel extraction.
9. Spectrophotometer for measurement of DNA concentration.
10. T4 DNA ligase and 10× buffer.
11. To make 10 mL ampicillin (100 mg/mL) stock: Add 1 g ampicillin to 10 mL Milli-Q water, sterilize by syringe filter of 0.2 μM pore size.
12. Chemically treated competent cells: *E. coli* DH5-α. Plasmid pUC57 and YE

FLAG

 carrying ampicillin resistance marker for positive screening.
13. Heat block/water bath for heat-shock of competent cells.

14. Mg^{2+} (2 M) stock: Add 2.033 g of $\text{MgCl}_2 \cdot 6\text{H}_2\text{O}$ and 2.465 g of $\text{MgSO}_4 \cdot 7\text{H}_2\text{O}$ into 10 mL of Milli-Q water. Sterilize by syringe filter of 0.2 μM pore size.
15. Glucose (2 M) stock: Add 3.604 g into 10 mL of Milli-Q water and dissolve by swirling. Sterilize by syringe filter of 0.2 μM pore size.
16. SOB media: Add 20 g tryptone, 5 g yeast extract, 0.584 g NaCl, and 0.186 g KCl to 800 mL of distilled water, dissolve the mixture by swirling, adjust pH to 7.0 and top up to 1 L. Sterilize by autoclaving and add 10 mL of 2 M Mg^{2+} stock.
17. SOC media: Add 99 mL of SOB media with 1 mL of 2 M glucose stock.
18. LB agar supplemented with 100 $\mu\text{g}/\text{mL}$ final concentration of ampicillin: Add 10 g of tryptone, 5 g of yeast extract, 10 g of NaCl, and 15 g of bacteriological agar into 800 mL of distilled water, dissolve the mixture by swirling and top up to 1 L. Sterilize by autoclaving and add 1 mL of ampicillin stock solution when the temperature has cooled to about 50 °C. Mix and pour into sterile petri dishes. Store refrigerated for up to 3 months.
19. LB broth supplemented with 100 $\mu\text{g}/\text{mL}$ final concentration of ampicillin: Add 10 g of tryptone, 5 g of yeast extract and 10 g of NaCl into 800 mL of distilled water, dissolve the mixture by swirling and top up to 1 L. Sterilize by autoclaving and add 1 mL of ampicillin stock solution when cooled. Store up to 3 months at room temperature.
20. Incubator for plate culture.
21. Shaking incubator for broth culture.

2.1.3 Transformation of the Expression Plasmid into Yeast

1. Minimal media supplemented with uracil and lysine, MM + UL (10 \times solutions): Add 6.7 g of yeast nitrogen base, 20 g of dextrose, 0.02 g of uracil and 0.03 g of lysine to 800 mL of distilled water. Dissolve the mixture by a magnetic stirrer and top up to 1 L with distilled water. Sterilize by syringe filtering using 0.2 μM pore size filter. For 1 \times broth media, add the stock to autoclaved distilled water; for 1 \times agar plate media, add autoclaved bacteriological agar and mix with the stock solution.
2. Yeast extract peptone dextrose (YPD) media: Add 10 g of yeast extract and 20 g of peptone into 800 mL of distilled water. Dissolve the mixtures by swirling and sterilize by autoclaving. Prepare dextrose separately to prevent caramelization by adding 20 g of dextrose into 200 mL of distilled water. Dissolve the mixture by a magnetic stirrer and sterilize by syringe filtering using 0.2 μM pore size. After the solution has cooled to room temperature, mix both solutions.

3. Bicine solution (1 M): Add 16.3 g of bicine into 80 mL of the Milli-Q water. Dissolve the mixtures by swirling. Adjust the pH to 8.35 and top up to 100 mL. Sterilize by syringe filter of 0.2 μ M pore size and store at -20°C .
4. Sorbitol bicine ethylene glycol (SBEG) buffer: Add 18.22 g of sorbitol, 1 mL of 10 mM bicine (pH 8.35) and 3 mL of ethylene glycol into 80 mL of Milli-Q water. Dissolve the mixtures by swirling and top up to 100 mL. Sterilize by syringe filter of 0.2 μ M pore size and store at -20°C .
5. PEG-bicine solution: Add 40 g of PEG 1000 and 20 mL of 200 mM Bicine (pH 8.35) into 50 mL of Milli-Q water. Dissolve the mixtures by swirling and top up to 100 mL. Sterilize by syringe filter of 0.2 μ M pore size and store at -20°C .
6. NaCl-bicine (NB) buffer: Add 3 mL of 5 M NaCl stock solution and 1 mL of 10 mM bicine (pH 8.35) and make up to 100 mL solution with Milli-Q water. Sterilize by syringe filtering using 0.2 μ M pore size and store at -20°C .
7. Incubator for plate culture.
8. Shaking incubator for broth culture.

2.1.4 Yeast Expression of Cathepsin Proteases

1. 20 % dextrose: Add 20 g of dextrose to 100 mL of distilled water. Dissolve the mixtures by swirling and sterilize by autoclaving.
2. 60 % glycerol: Add 60 mL of glycerol to 40 mL of distilled water. Sterilize the solution by autoclaving.
3. CaCl_2 (1 M): Add 14.7 g of $\text{CaCl}_2 \cdot 2\text{H}_2\text{O}$ to 80 mL of distilled water. Dissolve the mixtures by magnetic stirrer and top up to 100 mL. Sterilize by autoclaving.
4. Yeast expression media (YPHSM): Add 10 g of yeast extract and 80 g of peptone into 700 mL of distilled water and sterilize by autoclaving. Then, add in 50 mL of 20 % dextrose, 50 mL of 60 % glycerol and 20 mL of 1 M CaCl_2 .

2.1.5 Purification of Cathepsin Proteases

1. Centrifuge to pellet the cells.
2. Nickel-nitrilotriacetic acid chelated sepharose in a column for Immobilized-metal Affinity Chromatography (IMAC): Add 2 mL of nitrilotriacetic acid sepharose into a 5 mL polypropylene column and add Milli-Q water to wash off the ethanol used to suspend the sepharose. Then, add 1 mL of 0.2 M nickel sulfate into the column and wash with Milli-Q water again before equilibrate the sepharose with wash buffer containing 10 mM imidazole prior to use.
3. Tris-glycine SDS-PAGE loading dye, protein marker, Aquastain Stain for SDS-PAGE gel staining and 1 \times tris-glycine SDS PAGE buffer for running electrophoresis.

4. Tris-glycine SDS-PAGE running buffer (10×): Add 30.22 g of tris, 144.09 g of glycine and 10 g of SDS into 800 mL of Milli-Q water. Dissolve the mixture using a magnetic stirrer and top up to 1 L. Dilute to 1× solution prior to use.
5. NaCl (5 M): Add 146.1 g of NaCl to the 450 mL of Milli-Q water and mix with a magnetic stirrer. Top up to 500 mL.
6. Dialysis buffer (100 mM NaCl): Add 20 mL of NaCl stock (5 M) into 980 mL of Milli-Q water.
7. Imidazole (1 M): Add 34.04 g of imidazole into 450 mL of Mili-Q water and mix with a magnetic stirrer. Adjust to pH 7.6 and top up to 500 mL. Filter through a 0.45 µm pore size syringe filter.
8. NaH₂PO₄ (1 M): Add 69 g of NaH₂PO₄·H₂O in 450 mL of Mili-Q water. Dissolve the mixture and top up to 500 mL. Sterilize by autoclaving.
9. Wash buffer (25 mM NaH₂PO₄, 0.5 M NaCl, 10 mM imidazole): Mix 12.5 mL of NaH₂PO₄ (1 M), 50 µL of NaCl (5 M), 5 mL of imidazole (1 M) and top up to 500 mL with Mili-Q water.

2.1.6 *Animals and Vaccination*

1. Sprague Dawley male rats at 6 weeks.
2. Quil A (Sigma-Aldrich).

2.2 **DNA Vaccine**

2.2.1 *Bioinformatics Analysis and Synthesis of Cathepsin Protease Genes*

1. Extract gene sequence from GenBank, NCBI.
2. Expasy translation tool.
3. Analyze with codon optimization program.

2.2.2 *Construction of DNA Vaccines*

1. Synthetic gene in pUC57 cloning vector.
2. Cytoplasmic construct pVRI012.
3. Secretory construct pVRI020.
4. Chemokine-fused construct pMCP3.
5. Lymph node targeting construct pCTLA-4.
6. Cytoplasmic pMASIA.
7. CpG motifs-containing cytoplasmic pBISIA-40.

2.2.3 *Confirmation of Functional Expression of Antigen by Transfecting COS-7 Cells*

1. COS-7 cell line.
2. Lipofectamine reagent.
3. DMEM media.
4. 10 % new born calf serum (NCS).
5. 6-well sterile tissue culture plates.
6. 5 % CO₂ humidifier incubator.

7. Amicon ultrafiltration unit.
8. Western blot system.

2.2.4 Animals and Vaccinations

1. Female BALB/c mice.
2. Helios gene Gun System (Bio-Rad Laboratories).
3. NaCl (5 M): Add 146.1 g of NaCl to the 450 mL of Milli-Q water and mix with a magnetic stirrer. Top up to 500 mL.

3 Methods

3.1 Protein Vaccine

3.1.1 Bioinformatics Analysis and Synthesis of Cathepsin Protease Genes (See **Notes 1–3**)

1. Select cathepsin of interest as targeted antigen and download the gene sequence from GenBank.
2. Add appropriate different restriction enzyme recognition fragment (XhoI, NotI) at both ends of the gene sequence to ensure the gene insertion into the expression vector will be in correct orientation.
3. Insert the cathepsin sequence with a stop codon into the insertion site of the pFLAG.
4. Ensure the insert is in frame with the leader sequence encoded by the vector.
5. Insert the cathepsin gene sequence into a codon optimization program and select *S. cerevisiae* for codon optimization.
6. Download the codon-optimized sequence and use the sequence for gene synthesis.

3.1.2 Cloning of Cathepsin Proteases Gene into Expression Vector

1. Digest 1 µg of the cloning vector that carries the synthesized cathepsin gene as delivered by the gene synthesized company with the appropriate restriction enzymes (XhoI, NotI).
2. Inactivate the restriction enzyme by heating to 65 °C for 20 min.
3. Load the restriction digested products on a 1.5 % agarose gel and excise the gene fragment.
4. Recover the gene fragment from the agarose gel by using ISOLATE II PCR and Gel Kit.
5. Elute the gene fragment with 30 µL sterile Milli-Q water.
6. Similarly, digest the expression vector YEpFLAG with the same pair of the restriction enzymes and purify the linearized expression vector in the same way.
7. Measure the concentration of both gene fragment and vector.
8. Use the vector to insert molar ratio of 1:5 for ligation.
9. Thaw the chemical treated competent cells, *E. coli* strain DH5-α on ice for not more than 10 min.

10. Add 1 μL of the ligation product into the cells and keep on ice for 10–15 min.
11. Cell transformation is achieved by heat-shocking the mixture to 42 °C in a heating block for exactly 50 s.
12. Carefully transfer the cells and keep on ice for 2 min without shaking.
13. Aliquot 50 μL of the transformed cells to spread on a LB agar which is supplemented with 100 $\mu\text{g}/\text{mL}$ ampicillin.
14. Pick three colonies and subculture in LB broth. Incubate the culture at 200 rpm, 37 °C for 18 h.
15. Isolate the plasmid using the ISOLATE II plasmid mini kit and confirm the insert by restriction enzyme digestion.

3.1.3 Transformation of the Expression Plasmid into Yeast

1. Inoculate a pure culture of yeast strain BJ3505 into 10 mL of YPD media and incubate for 48 h at 30 °C with 160 rpm shaking (*see Note 4*).
2. Add the 10 mL culture into 100 mL of fresh YPD media and further incubate with the same incubation condition until the absorbance measure at 600 nm reaches about 0.6.
3. Aliquot 10 mL of the culture and centrifuge at $5000\times g$ for 2 min at room temperature.
4. Discard the supernatant and resuspend the pellet with 5 mL SBEG.
5. Centrifuge the mixture again and resuspend the cells with 200 μL SBEG and incubate at 30 °C with 160 rpm shaking for 5 min.
6. Add 1 μg of the expression plasmid to the cells and incubate at 30 °C for 10 min without shaking.
7. Place the cells at –80 °C freezer for 30 min and then thaw in a 37 °C water bath with gentle agitation.
8. Add 1.5 mL of PEG-Bicine into the cells and mix gently.
9. Incubate the cell mixture at 30 °C for 1 h without shaking.
10. Add 2 mL of NB buffer to the cells and mix by inversion and then centrifuge at $5000\times g$ for 5 min.
11. Discard the supernatant and resuspend with 500 μL NB buffer.
12. Aliquot 50 μL of the cells and spread on the MM+UL agar plate.
13. Incubate the plate at 30 °C for 7 days.

3.1.4 Yeast Expression of Cathepsin Proteases (See Note 5)

1. Inoculate a positive clone into 200 mL MM+UL and incubate for 72 h with 160 rpm shaking at 28 °C.

2. Pellet the yeast cells at $5000 \times g$ for 10 min and inoculate into 2 L of YPHSM.
3. Incubate the cells in YPHSM by shaking at 160 rpm for 72 h at 28 °C.

3.1.5 Purification of Cathepsin Proteases

1. Collect the cells at $10,000 \times g$ centrifugation for 10 min and keep the supernatant.
2. Dialyze the supernatant in dialysis buffer for four times (5 L of dialysis buffer for 1 L of supernatant) in a cold room, stirring with magnetic stirrer, at least 4 h apart between each dialysate change (*see* **Notes 6** and **7**).
3. Make up the supernatant to 25 mM NaH_2PO_4 , 0.5 M NaCl and 10 mM imidazole at pH 7.6.
4. Centrifuge the dialysed supernatant at $15,000 \times g$ for 10 min to remove any precipitate.
5. Use syringe to filter (0.45 μm pore size) dialyzed sample to further remove any particulate matter.
6. Capture the 6 x histidine tagged protein using nitrilotriacetic acid (NTA) resin pre-charged with nickel in a chromatography column.
7. Wash the cathepsin proteases with wash buffer containing 50 and 100 mM imidazole and finally elute with elution buffer containing 250 mM imidazole.
8. To analyze the sample on SDS-PAGE, add 5 μL of 3 \times SDS-PAGE loading buffer to 20 μL of the eluted fractions and boil the mixture at 100 °C for 5 min.
9. Allow the temperature of the sample to cool to room temperature and load into a 10 % tris-glycine SDS PAGE gel, run electrophoresis at 60 V for the first 30 min and at 180 V for the next 50 min.
10. Visualize the cathepsin proteases by staining with Aquastain solution.

3.1.6 Formulation of Vaccine

1. Add 20 μg of recombinant cathepsin protease in 200 μL 0.9 % saline with 1 mg/mL Quil A.

3.2 DNA Vaccine

3.2.1 Bioinformatics Analysis and Synthesis of Cathepsin Protease Genes (See **Note 8**)

1. Select cathepsin of interest as targeted antigen and download the gene sequence from GenBank.
2. Add appropriate different restriction enzyme recognition fragment at both ends of the gene sequence to ensure the gene insertion into the expression vector will be in correct orientation.
3. Insert the cathepsin sequence into the insertion site of the DNA vector.

3.2.2 Cloning
of Cathepsin Proteases
Gene into DNA Vaccine
Vector

4. Ensure the inserts are in frame and use the sequence for gene synthesis (*see Note 9*).

1. Digest 1 µg of the cloning vector that carries the synthesized cathepsin gene as delivered by the gene synthesized company with the appropriate restriction enzymes.
2. Inactivate the restriction enzyme by heating to 65 °C for 20 min.
3. Load the restriction digested products on a 1.5 % agarose gel and excised the gene fragment.
4. Recover the gene fragment from the agarose gel by using ISOLATE II PCR and Gel Kit.
5. Elute the gene fragment with 30 µL sterile Milli-Q water.
6. Similarly, digest the DNA vaccine vector with the same pair of the restriction enzymes used to digest the cathepsin proteases gene and then gel purify of linearized vector.
7. Measure the concentration of both gene fragment and vector.
8. Use the vector to insert molar ratio of 1:5 for ligation.
9. Thaw the chemical treated competent cells, *E. coli* strain DH5-α on ice for not more than 10 min.
10. Add in 1 µL of the ligation product into the cells and keep on ice for 10–15 min.
11. Cell transformation is achieved by heat-shocking the mixture to 42 °C in a heating block for exactly 50 s.
12. Carefully transfer the cells and keep on ice for 2 min without shaking.
13. Aliquot 50 µL of the transformed cells to spread on a LB agar which has supplemented with 100 µg/mL ampicillin.
14. Pick three colonies and subculture in LB broth. Incubate the culture at 200 rpm, 37 °C for 18 h.
15. Isolate the plasmid using the ISOLATE II plasmid mini kit and confirm the insert by enzyme digestion and sequencing.
16. Keep the sequence verified construct in DH5-α at –80 °C with 20 % glycerol.

3.2.3 Purification
of Plasmid DNA
for Vaccination

1. Subculture the sequence verified construct in LB broth for overnight at 37 °C with 200 rpm shaking.
2. Purify the construct using an endotoxin free plasmid Giga kit.
3. Dilute the purified DNA in endotoxin free 0.9 % saline solution at a concentration of 1 mg/mL.

3.2.4 Confirmation
of Functional Expression
of Antigen by Transfecting
COS-7 Cells

1. Grow the COS-7 cells in DMEM medium supplemented with 10 % new born calf serum (NCS).

2. One the day before transfection, seed the cells in 6-well sterile tissue plates in 2 mL complete medium and incubate in a 5 % CO₂ humidifier at 37 °C until the cells attain 80 % confluency.
3. Add 4 µg of plasmid to 100 µL of DMEM media without newborn calf serum (NCS) 20 µL of lipofectamine LTX reagent and incubate for 5 min at room temperature.
4. Add the mixture to COS-7 cells and further incubate for 24 h at 37 °C.
5. Add 1 mL of the complex DMEM media with NCS (10 %) to the cells and further incubate for 48 h at 37 °C.
6. Wash the cells with PBS and growth media without NCS and incubate further for 24 h.
7. Harvest the cells and concentrate the supernatant using an Amicon ultrafiltration unit (cut off value 15 kDa).
8. Analyze the concentrated supernatant by SDS-PAGE and western blotting.

3.2.5 Mice and Vaccinations

1. For intramuscular vaccination, prepare 50 µL of 1 mg/mL DNA in 0.9 % NaCl.
2. Inject the vaccine into the midpoint of each thigh muscle.
3. For intradermal vaccination, precipitate 100 µg of plasmid DNA onto 50 mg gold microcarriers (average diameter 1.6 µm) and then use the particles to coat tubing.
4. Cut the tubing into cartridges such that vaccination with a single cartridge will deliver 1 µg of plasmid DNA.
5. Clip and shave the abdominal region of the mouse prior to vaccination.
6. Deliver the particles by a pulse of helium gas at 400 psi.

4 Notes

1. The recombinant cathepsin proteases in the yeast expression vector YEpFLAG will be directed to be secreted by the alpha factor pre-pro leader. The protein sequence labeled with 6× His-tag at the C-terminus will facilitate the downstream purification process. Extension of the cathepsin proteases sequence at the N-terminus with a spacer sequence greatly increased the Kex2p catalytic efficiency which is essential in facilitating efficient cleavage of the alpha factor leader sequence and minimizing hyperglycosylation [38]. Absence of the spacer sequence would cause the retention of recombinant cathepsin in the endoplasmic reticulum [39]. The annotated pFLAG map and

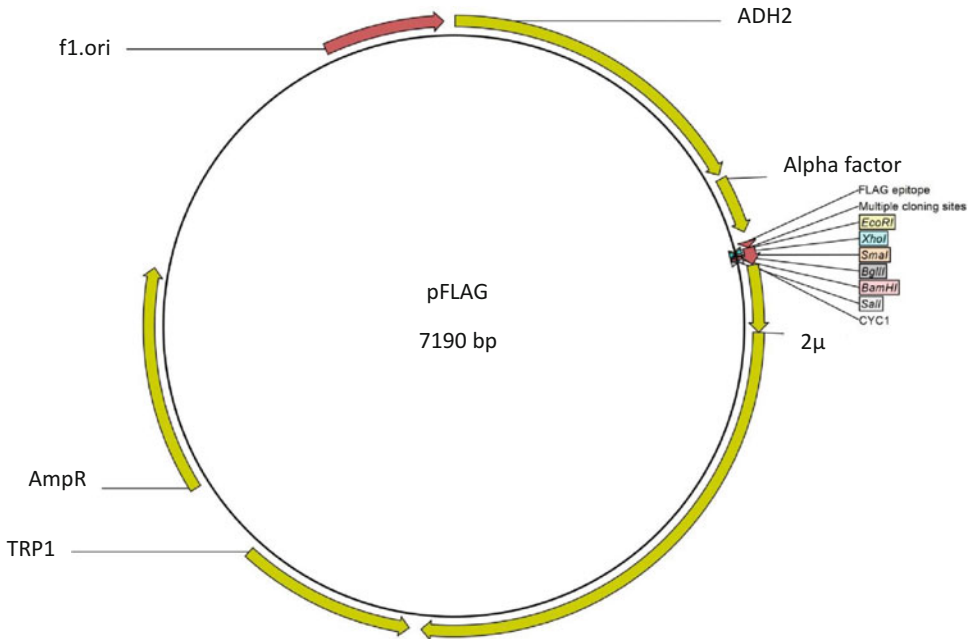

Fig. 3 Diagrammatic representation of pFLAG constructs. The genes encoding cathepsin proteases are inserted within the multiple cloning sites with various options of restriction enzyme recognition site for gene insertion. Other features of YEpFLAG are: AmpR and TRP1, which allow for selection in *E. coli* and *S. cerevisiae*, respectively; CYC1 transcription termination and; the 2 μ ori which allows for the replication of the plasmid in *S. cerevisiae*

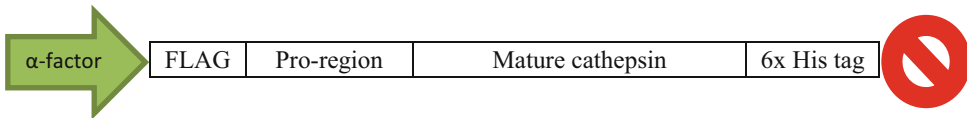

Fig. 4 Diagrammatic representation of the cathepsin proteases gene component encoded by pFLAG. The constructs encode the α -factor signal sequence, FLAG epitope/spacer sequence, pro and mature regions of the cathepsin proteases gene and a C-terminus polyhistidine tag. The α -factor signal sequence will be cleaved off upon secretion into the culture media and the FLAG epitope will be removed together with the pro region while activation of the enzyme

the arrangement of the recombinant cathepsin gene are shown in Figs. 3 and 4, respectively.

2. The N-terminus spacer sequence was not expected to affect enzyme specificity as the pro region is cleaved during activation of the mature enzyme.
3. Stop codon needs to be added to the gene sequence as the YEpFLAG vector lacks a translational stop signal. The YEpFLAG vector uses the ADH₂ gene promoter to regulate transcription, where the promoter is tightly repressed in the presence of dextrose. The yeast cells are therefore grown in the

presence of dextrose which will be consumed during yeast metabolism, eventually reaching a level at which it is no longer repressing the ADH₂ promoter and the recombinant protein will be produced and secreted into the extracellular space.

4. Yeast (*S. cerevisiae*) strain BJ3505 is carrying mutant uracil, lysine, and tryptophan genes which would be utilized in the selection of positive transformants as the expression vector, pFLAG, contains a complementary tryptophan encoding gene. In addition, strain BJ3505 is protease deficient which will minimize recombinant protease degradation.
5. In general, the passage of the recombinant proteins through the secretory pathway allows posttranslational event such as proteolytic maturation, glycosylation, and most importantly disulfide bond formation. The secretion of the recombinant proteins into the culture media could avoid toxicity from accumulated material in the cells and simplify protein purification process as yeast secretes relatively low levels of native proteins.
6. Prepare dialysis tubing membrane according to the manufacturer's instruction, where some of the tubing is required to be boiled prior to use. Make sure to choose the correct molecular weight cutoff value of the membrane pore size which should be considerably smaller than the targeted proteins.
7. The length of the dialysis tubing should be longer than just enough to fill all the sample as the water molecules from the dialysate will diffuse into the tubing via osmosis faster than the buffer salts within the sample could diffuse out due to the high salt concentration in the expression media. Osmosis will cause the swelling of the tubing. To concentrate the sample, using polyethylene glycol compound as the dialysate is the method of choice. The molecular size of the polyethylene glycol compound should be larger than the pore size of the tubing membrane to avoid contamination.
8. While DNA vaccines are capable of transfecting professional antigen presenting cells, and can stimulate both humoral and cellular immunity, immune responses elicited are far less than those induced by protein vaccines [40]. The strategies applied to increase the protective immune responses elicited by DNA vaccines are use of secretory vectors, cytoplasmic vectors, use of chemokines for targeting antigen to antigen presenting cells via chemokine receptors [18], and incorporating CpG motifs into the plasmid DNA backbone as unmethylated CpG motif has been found to be a ligand for Toll-like receptor 9 (TLR9) [41].
9. During bioinformatics analysis of the construct for both protein expression and DNA vaccine, it is important to ensure the inserted gene will be translated in frame.

Acknowledgements

We thank Drs Luke Norbury and Rama Jayaraj for undertaking much of the work described here.

References

- Spithill T, Smooker P, Copeman B (1999) *Fasciola gigantica*: epidemiology, control, immunology and molecular biology. In: Dalton JP (ed) Fasciolosis. CAB International, Wallingford, UK, pp 465–525
- Rim HJ, Farag HF, Sornmani S, Cross JH (1994) Food-borne trematodes: ignored or emerging? *Parasitol Today* 10(6):207–209
- Mas-Coma MS, Esteban JG, Bargues MD (1999) Epidemiology of human fascioliasis: a review and proposed new classification. *Bull World Health Organ* 77: 340–346
- Fairweather I (2009) Triclabendazole progress report, 2005–2009: an advancement of learning? *J Helminthol* 83:139–150
- Gordon D, Zadoks R, Skuce P, Sargison N (2012) Confirmation of triclabendazole resistance in liver fluke in the UK. *Vet Rec* 171: 159–160
- Brockwell YM, Elliott TP, Anderson GR, Stanton R, Spithill TW, Sangster NC (2014) Confirmation of *Fasciola hepatica* resistant to triclabendazole in naturally infected Australian beef and dairy cattle. *Int J Parasitol Drugs Drug Resist* 4:48–54
- Allen JE, Maizels RM (2011) Diversity and dialogue in immunity to helminths. *Nat Rev Immunol* 11:375–388
- Allen JE, Wynn TA (2011) Evolution of Th2 immunity: a rapid repair response to tissue destructive pathogens. *PLoS Pathog* 7(5): e1002003
- James SL, Glaven J (1989) Macrophage cytotoxicity against schistosomula of *Schistosoma mansoni* involves arginine-dependent production of reactive nitrogen intermediates. *J Immunol* 143:4208–4212
- Pulendran B, Smith JL, Caspary G, Brasel K et al (1999) Distinct dendritic cell subsets differentially regulate the class of immune response *in vivo*. *Proc Natl Acad Sci U S A* 96:1036–1041
- Wiedosari E, Hayakawa H, Copeman B (2006) Host differences in response to trickle infection with *Fasciola gigantica* in buffalo, Ongole and Bali calves. *Trop Anim Health Prod* 38:43–53
- Raadsma HW, Kingsford NM, Suharyanta, Spithill TW, Piedrafito D (2007) Host responses during experimental infection with *Fasciola gigantica* or *Fasciola hepatica* in Merino sheep: I. Comparative immunological and plasma biochemical changes during early infection. *Vet Parasitol* 143:275–286
- Hansen DS, Clery DG, Estuningsih SE, Widjajanti S, Partoutomo S, Spithill TW (1999) Immune responses in Indonesian thin tail and Merino sheep during a primary infection with *Fasciola gigantica*: lack of a specific IgG2 antibody response is associated with increased resistance to infection in Indonesian sheep. *Int J Parasitol* 29:1027–1035
- Acosta D, Cancela M, Piacenza L, Roche L, Carmona C, Tort JF (2008) *Fasciola hepatica* leucine aminopeptidase, a promising candidate for vaccination against ruminant fasciolosis. *Mol Biochem Parasitol* 158:52–64
- Sexton JL, Wilce MC, Colin T, Wijffels GL et al (1994) Vaccination of sheep against *Fasciola hepatica* with glutathione S-transferase. Identification and mapping of antibody epitopes on a three-dimensional model of the antigen. *J Immunol* 152:1861–1872
- Kennedy NJ, Spithill TW, Tennent J, Wood PR, Piedrafito D (2006) DNA vaccines in sheep: CTLA-4 mediated targeting and CpG motifs enhance immunogenicity in a DNA prime/protein boost strategy. *Vaccine* 24: 970–979
- Jayaraj R, Piedrafito D, Dynon K, Grams R, Spithill TW, Smooker PM (2010) Liver fluke vaccines: vaccination against fasciolosis by a multivalent vaccine of recombinant stage-specific antigens. *Proc Vaccinol* 2:82–85
- Jayaraj R, Piedrafito D, Spithill T, Smooker P (2012) Evaluation of the immune responses induced by four targeted DNA vaccines encoding the juvenile liver fluke antigen, cathepsin B in a mouse model. *Genet Vaccines Ther* 10:7
- Piacenza L, Acosta D, Basmadjian I, Dalton JP, Carmona C (1999) Vaccination with cathepsin L proteinases and with leucine aminopeptidase induces high levels of protection against fascioliasis in sheep. *Infect Immun* 67:1954–1961

20. Maggioli G, Acosta D, Silveira F, Rossi S et al (2011) The recombinant gut-associated M17 leucine aminopeptidase in combination with different adjuvants confers a high level of protection against *Fasciola hepatica* infection in sheep. *Vaccine* 29:9057–9063
21. Morphew RM, Wright HA, LaCourse EJ, Woods DJ, Brophy PM (2007) Comparative proteomics of excretory-secretory proteins released by the liver fluke *Fasciola hepatica* in sheep host bile and during in vitro culture ex host. *Mol Cell Proteomics* 6:963–972
22. Robinson MW, Tort JF, Lowther J, Donnelly SM et al (2008) Proteomics and phylogenetic analysis of the cathepsin L protease family of the helminth pathogen *Fasciola hepatica*: expansion of a repertoire of virulence-associated factors. *Mol Cell Proteomics* 7:1111–1123
23. Dalton JP, McGonigle S, Rolph TP, Andrews SJ (1996) Induction of protective immunity in cattle against infection with *Fasciola hepatica* by vaccination with cathepsin L proteinases and with hemoglobin. *Infect Immun* 64:5066–5074
24. Dalton JP, Neill SO, Stack C, Collins P et al (2003) *Fasciola hepatica* cathepsin L-like proteases: biology, function, and potential in the development of first generation liver fluke vaccines. *Int J Parasitol* 33:1173–1181
25. Norbury LJ, Beckham S, Pike RN, Grams R et al (2011) Adult and juvenile *Fasciola* cathepsin L proteases: different enzymes for different roles. *Biochimie* 93:604–611
26. Norbury LJ, Hung A, Beckham S, Pike RN, Spithill TW, Craik CS, Choe Y, Fecondo JV, Smooker PM (2012) Analysis of *Fasciola* cathepsin L5 by S2 subsite substitutions and determination of the P1–P4 specificity reveals an unusual preference. *Biochimie* 94:1119–1127
27. Lecaillon F, Choe Y, Brandt W, Li Z, Craik CS, Bromme D (2002) Selective inhibition of the collagenolytic activity of human cathepsin K by altering its S2 subsite specificity. *Biochemistry* 41:8447–8454
28. Turk D, Guncar G, Podobnik M, Turk B (1998) Revised definition of substrate binding sites of papain-like cysteine proteases. *Biol Chem* 379:137–147
29. Smooker PM, Steeper KR, Drew DR, Strugnelli RA, Spithill TW (1999) Humoral responses in mice following vaccination with DNA encoding glutathione S-transferase of *Fasciola hepatica*: effects of mode of vaccination and the cellular compartment of antigen expression. *Parasite Immunol* 21:357–364
30. Mattanovich D, Branduardi P, Dato L, Gasser B et al (2012) Recombinant protein production in yeasts. *Methods Mol Biol* 824:329–358
31. Kutzler MA, Weiner DB (2008) DNA vaccines: ready for prime time? *Nat Rev Genet* 9:776–788
32. Babiuk LA, Pontarollo R, Babiuk S et al (2003) Induction of immune responses by DNA vaccines in large animals. *Vaccine* 21:649–658
33. Leung JY, Pijlman GP, Kondratieva N, Hyde J et al (2008) Role of nonstructural protein NS2A in flavivirus assembly. *J Virol* 82:4731–4741
34. Mutwiri G, Pontarollo R, Babiuk S, Griebel P et al (2003) Biological activity of immunostimulatory CpG DNA motifs in domestic animals. *Vet Immunol Immunopathol* 91:89–103
35. Klinman DM, Currie D, Gursel I, Verthelyi D (2004) Use of CpG oligodeoxynucleotides as immune adjuvants. *Immunol Rev* 199:201–216
36. Estuningsih SE, Smooker PM, Wiedosari E, Widjajanti S et al (1997) Evaluation of antigens of *Fasciola gigantica* as vaccines against tropical fasciolosis in cattle. *Int J Parasitol* 27:1419–1428
37. Jayaraj R, Piedrafita D, Dynon K, Grams R, Spithill TW, Smooker PM (2009) Vaccination against fasciolosis by a multivalent vaccine of stage-specific antigens. *Vet Parasitol* 160:230–236
38. Kjeldsen T, Brandt J, Andersen AS, Egel-Mitani M et al (1996) A removable spacer peptide in an alpha-factor-leader/insulin precursor fusion protein improves processing and concomitant yield of the insulin precursor in *Saccharomyces cerevisiae*. *Gene* 170:107–112
39. Lesage G, Prat A, Lacombe J, Thomas DY et al (2000) The Kex2p proregion is essential for the biosynthesis of an active enzyme and requires a C-terminal basic residue for its function. *Mol Biol Cell* 11:1947–1957
40. Cui Z (2005) DNA vaccine. In: Leaf Huang M-CH, Ernst W (eds) *Advances in genetics*, vol 54. Academic, San Diego, CA, pp 257–289
41. Hemmi H, Takeuchi O, Kawai T, Kaisho T et al (2000) A Toll-like receptor recognizes bacterial DNA. *Nature* 408:740–745

Chapter 10

Towards a Preventive Strategy for Toxoplasmosis: Current Trends, Challenges, and Future Perspectives for Vaccine Development

Ragab M. Fereig and Yoshifumi Nishikawa

1 Introduction

Toxoplasmosis, caused by the unicellular intracellular protozoan parasite *Toxoplasma gondii*, is a cosmopolitan disease infecting almost all endothermic animals, including humans. Human infections with *T. gondii* are primarily symptomless and induce a self-limiting disease in immunocompetent individuals. However, in immunocompromised individuals the effects of infection are much more severe. Furthermore, vertical transmission during pregnancy can induce miscarriage, cerebral lesions, and ocular complications [1]. Toxoplasmosis in animals, mainly sheep and goats, has great economic impact as it causes abortions, stillbirths, and neonatal fatalities. Additionally, the consumption of raw or semi-cooked meat contaminated with tissue cysts of *T. gondii* is considered the main route of parasite transmission to humans [2]. During infection, the parasite disseminates throughout the body and converts from tachyzoites to bradyzoites (tissue cysts forms), which are kept under control, but not entirely eliminated by the host's cellular immune responses; hence, medical intervention is required [3]. *T. gondii* has a complex life cycle, making development of a potent vaccine to reduce the hazards of toxoplasmosis far from straightforward. As a heteroxenous pathogen, *T. gondii* requires multiple hosts to complete its life cycle. The life cycle includes a sexual stage in the definitive host (wild or domestic felines) characterized by sporozoites in sporulated oocysts, and asexual stages represented by tachyzoites (the rapidly proliferative forms) and bradyzoites (the dormant forms), both of which occur in the definitive and intermediate hosts [4, 5]. Establishment of novel control and prevention strategies for toxoplasmosis is essential for protecting

public health and livestock production. Currently, only one commercial vaccine (Toxovax[®], Intervet), based on live attenuated tachyzoites of the *T. gondii* S48 strain, is available for veterinary use in a limited number of countries, where it is used primarily for minimizing the incidence of abortion in sheep [6]. This vaccine has certain disadvantages and cannot be used for humans as because live vaccines possess the capacity to restore parasite virulence and provoke iatrogenic infection [7]. Moreover, most available drugs used for treatment and control of toxoplasmosis have several limitations; hence, discovery of highly effective and safe chemotherapies remains an essential goal. Whereas some of the drugs in use for toxoplasmosis are only partially effective in treating acute infections, their efficacy is abrogated for treatment of chronic infections, and most have high toxicity [8]. Also, there are currently no effective treatments that can prevent the severe neurological, ocular, cardiac and cerebral anomalies characteristic of congenital toxoplasmosis contracted during pregnancy [9]. This situation makes development of an effective and safe vaccine against *T. gondii* critical for controlling this parasitic infection in humans and animals. In the last few years the most extensive vaccine trials have been focused on the use of recombinant subunit vaccines (DNA and protein subunit vaccine). The merits of such vaccines have been investigated in terms of their potential to elicit long lasting cellular and humoral immunity, as well as their safety and overall costs. DNA and protein subunit vaccines are based on certain parasite molecules, particularly those participating in host-parasite interactions. With DNA vaccines, the target parasite gene is inserted into a eukaryotic vector that has the capacity to express the parasite antigen inside the immunized host. In contrast, recombinant protein vaccines comprise a pre-prepared parasite antigen previously expressed in a prokaryotic or eukaryotic vector in *E. coli* cells. In last decade, recombinant DNA vaccines have achieved significant advances in triggering potent immune responses and inducing high levels of protection [10–14]. Similar successes were reported for recombinant protein vaccines [15–18]. Additionally, a revolution is taking place in the processing and use of recombinant protein vaccines by blending them with adjuvant substances that can act as antigen agonists, thereby improving their protective efficacy. Numerous types of adjuvants have been evaluated in immunization experiments, including chemically formulated ones and those of natural origin. Most of the adjuvants used in such vaccines have succeeded in potentiating the antigen's protective efficacy and increasing the safety of the vaccine [11, 19–21]. In this review, we describe the latest advances in recombinant DNA- and protein-based adjuvant vaccines and discuss the methodologies of two published papers on specific *Toxoplasma* antigens as models for preparation of each type of vaccine.

2 Materials

2.1 Recombinant TgAMA1 DNA Vaccine [22]

1. Eagle's minimum essential medium (EMEM; Sigma-Aldrich, St. Louis, MO, USA).
2. Dulbecco's modified Eagle's medium (DMEM; Sigma-Aldrich).
3. Fetal bovine serum (FBS, Nichirei Bioscience, Tokyo, Japan).
4. 5.0- μ m pore filter (Millipore, Bedford, MA, USA).
5. Isopropyl-1-thio B-d galactopyranoside (IPTG; Wako, Osaka, Japan).
6. 2,2 Azino-bis (3-ethylebenzothiazoline-6-sulfonic acid) diammonium salt (ABTS; Sigma-Aldrich).
7. Lipofectamine 2000 reagent (Thermo Fisher Scientific, Waltham, MA, USA).
8. Bovine serum albumin (BSA; Sigma-Aldrich).
9. pcDNA3.1 vector (Thermo Fisher Scientific).
10. Horseradish peroxidase (HRP)-conjugated goat anti-mouse IgG, IgG1, IgG2a (Bethyl Laboratories, Montgomery, TX, USA).
11. IFN- γ and IL-4 cytokine ELISA kits (BD Bioscience, San Diego, CA, USA).
12. Helios gene gun (Bio-Rad Laboratories, Hercules, CA, USA).
13. Buffers and diluents.
 - (a) 0.05 M Carbonate Buffer, pH 9.6: NaHCO_3 (2.93 g) + Na_2CO_3 (1.59 g) dissolved in 900 ml of distilled water (DW) followed by pH adjustment to 9.6 by adding HCl or NaOH before making the solution up to 1000 ml.
 - (b) Phosphate Buffered Saline Tween (PBST) 10 \times , pH 7.4: NaCl (160 g) + KCl (4 g) + KH_2PO_4 (4 g) + $\text{Na}_2\text{PO}_4 \cdot 12\text{H}_2\text{O}$ (58 g) dissolved in 1800 ml DW followed by pH adjustment to pH 7.4 before making the solution up to 2000 ml.
 - (c) ABTS Buffer, pH 4.0: (a) Citric acid monohydrate (10.507 g) dissolved in 500 ml of DW. (b) $\text{Na}_2\text{HPO}_4 \cdot 12\text{H}_2\text{O}$ (35.814 g) dissolved in 500 ml of DW. Buffer A should be adjusted to pH 4.0 by addition of buffer B and then kept at 4 $^\circ\text{C}$.
 - (d) Substrate solution: ABTS (solid) 3 mg is dissolved thoroughly in 10 ml of ABTS buffer, and 1 μ l of 30 % H_2O_2 is added just before use.
 - (e) 3% skimmed milk (Indirect ELISA diluent): 3 g of skimmed milk powder is dissolved thoroughly in phosphate buffered saline.
 - (f) 10 % FBS (Sandwich ELISA diluent): 5 ml of heat-inactivated BS is mixed with phosphate buffered saline.

**2.2 Oligomannose-
Entrapped Recombinant
Protein [23]**

1. EMEM.
2. RPMI-1640 (Sigma-Aldrich).
3. pGEX-4T1 plasmid vector (Amersham Pharmacia Biotech, Madison, CA, USA).
4. *E. coli* DH5 α (Takara Bio Inc., Shiga, Japan).
5. 5.0- μ m pore filter (Millipore).
6. 1 μ m-pore-size polycarbonate membrane (Nuclepore, Pleasanton, CA, USA).
7. Modified Lowry protein assay kit (Pierce Biotechnology, Inc., Rockford, IL, USA).
8. Bicinchoninic acid assay kit (BCA; Pierce Biotechnology, Inc).
9. BSA.
10. ABTS.
11. IPTG.
12. l-Glutathione, reduced (Sigma-Aldrich).
13. TNE (100 mM Tris-HCl, 100 mM NaCl, 5 mM EDTA, prepared in distilled water at 10 ml volume).
14. Glutathione-Sepharose 4B beads (GE Healthcare Life Sciences, Buckinghamshire, UK).
15. Detoxi-Gel endotoxin removing gel (Pierce Biotechnology, Inc.).
16. Limulus amoebocyte Lysate (LAL) reagents (Seikagaku Inc., Japan).
17. Coomassie brilliant blue R250 staining (MP Biomedicals Inc., France).
18. Concanavalin A (Con A) (Sigma-Aldrich).
19. SYBR-Green PCR Master Mix (Applied Biosystems, Warrington, UK).
20. IFN- γ , IL-4, and IL-10 cytokine ELISA kits (BD Bioscience).
21. SuperScript[®] First-Strand Synthesis System for RT-PCR (Invitrogen, Mount Waverley, Australia).
22. TRI reagent (Sigma-Aldrich).
23. Buffers and diluents (as previously described).
 - (a) 0.05 M Carbonate Buffer, pH 9.6.
 - (b) PBST 10 \times , pH 7.4.
 - (c) ABTS Buffer, pH 4.0.
 - (d) Substrate solution.
 - (e) 3 % skimmed milk (Indirect ELISA diluent).
 - (f) 10 % FBS (Sandwich ELISA diluent).

3 Methods

3.1 Recombinant DNA Vaccine

Immunization with *T. gondii* AMA1 DNA vaccine [22].

1. Navigate the coding sequence of *T. gondii* AMA gene (RH strain) from its cDNA sequence (toxodb.org) and design forward and reverse primers containing *EcoRI* restriction sites including ATG start codon in the forward primer and a TAG stop codon in the reverse primer. P1 (5'-CT GAA TTC **ATG** CTC AAG CAC AAG CTC TCG CGA GTC G-3') and P2 (5'-CT **TAG** GAA TTC TTC TGA CTC TAG TAA TCC CCC TCG AC-3') (*see Note 1*).
2. Wash and scrape *T. gondii* tachyzoites (RH strain) infected African green monkey kidney (Vero) cells.
3. Wash the parasites and host cell debris with cold PBS, resuspend the final pellet in cold PBS, and pass through a syringe fitted with a 27-gauge needle three times.
4. Pass the parasites through a 5.0- μm pore filter, wash them thoroughly with PBS (10 ml), and then centrifuge at $1500\times g$ for 10 min.
5. Extract total RNA from the parasites using TRI reagent.
6. Conduct first-strand cDNA synthesis from total parasite RNA with a SuperScript® First-Strand Synthesis System for RT-PCR.
7. Amplify the coding sequence of the TgAMA1 gene using TgAMA1-specific oligonucleotide primers.
8. Digest the PCR products with *EcoRI* and insert into the eukaryotic expression vector pcDNA3.1, which has been digested with the same set of restriction enzymes to produce the pAMA1 construct (*see Notes 2 and 3*).
9. Mix the plasmid construct with transfection Lipofectamine 2000 reagent in FBS and antibiotic free DMEM medium at a final concentration of 10 $\mu\text{g}/\text{ml}$.
10. Inoculate the lipofectamine–plasmid mixture into HeLa cells and incubate at 37 °C in a 5 % CO₂ atmosphere for 6 h (*see Note 4*).
11. Supplement with fresh medium and incubate again for 48 h. Collect the transfected HeLa cells to confirm gene expression and protein production via western blotting and an indirect fluorescent antibody technique, respectively.
12. Dilute the pAMA1 recombinant plasmid in PBS at a concentration of 0.5 $\mu\text{g}/\mu\text{l}$ in a 50 μg total quantity.
13. Inject the mixture intramuscularly into C57BL/6 mice using a Helios gene gun at weeks 0, 2 and 4 (*see Note 5*), and then challenge the mice with 1×10^3 PLK tachyzoites 3 weeks after their last immunization.

14. Estimate the level and mechanism of protection and determine the survival rates by daily observation of the mice (*see Note 6*). Additionally, measure the generation of specific antibodies (*see Note 7*) and IL-4 and IFN- γ cytokine levels in splenocyte culture supernatants (*see Notes 8 and 9*).

3.2 Recombinant Protein plus Adjuvant as a Vaccine

Vaccination with *T. gondii* profilin entrapped in oligomannose-coated liposomes (OML) [23].

1. Search the coding sequence of the *T. gondii* profilin (TgPF) gene (PLK strain) from cDNA (toxodb.org) and design forward and reverse primers against it. The following oligonucleotide primers include an *Eco*RI site in the forward primer 5'-AT GAA TTC ATG TCC GAC TGG GAC CCT GTT-3' and an *Xho*I site in the reverse primer 5'-TA CTC GAG TTA GTA CCC AGA CTG GTG AAG-3'.
2. Purify *T. gondii* tachyzoites (PLK strain) from Vero cells (*see Note 10*).
3. Wash the parasites and host cell debris with cold PBS, resuspend the final pellet in cold PBS, and pass through a syringe fitted with a 27-gauge needle three times.
4. Pass the parasites through a 5.0- μ m pore filter, wash them thoroughly with 10 ml of PBS, and then centrifuge at 1500 \times g for 10 min.
5. Extract total RNA from the parasites using TRI reagent (*see Note 11*).
6. Synthesize first-strand cDNA from total parasite RNA with the SuperScript[®] First-Strand Synthesis System for RT-PCR according to the manufacturer's instructions (*see Note 12*).
7. Amplify the coding sequence of the target TgPF gene with the set of oligonucleotide primers designed previously.
8. Digest the PCR products with *Eco*RI and *Xho*I and clone into the prokaryotic expression vector pGEX-4T1 previously digested with the same set of restriction enzymes to produce the pTgPF construct (*see Note 13*).
9. TgPF is expressed as a glutathione *S*-transferase (GST) fusion protein in the *E. coli* DH5 α cells (*see Note 14*).
10. Remove the GST-tag of the recombinant TgPF protein with thrombin protease according to the manufacturer's recommendations.
11. Test the purity of the purified protein by sodium dodecyl sulfate-polyacrylamide gel electrophoresis (SDS-PAGE) (*see Note 15*).
12. Remove the endotoxin from the prepared protein using endotoxin removing gel (Detoxi-gel) and measure the protein concentration with BCA protein assay reagent.

13. In a conical flask, prepare liposomes by adding chloroform–methanol (2:1 [vol/vol]) solution containing 1.5 μmol of dipalmitoylphosphatidylethanolamine (DPPE) and 1.5 μmol of cholesterol and dry the solution by rotary evaporation (*see Note 16*).
14. To prepare a lipid film containing neoglycolipid, place 2 ml of chloroform containing 0.15 μmol of mannotriose-DPPE (Man3-DPPE) in a flask and evaporate the contents.
15. Add 200 μl of PBS containing the recombinant TgPF protein (500 $\mu\text{g}/\text{ml}$) to the dried lipid film, and form multilamellar vesicles by intense vortex dispersion.
16. Extrude the multilamellar vesicles ten times through a 1- μm -pore-size polycarbonate membrane.
17. Isolate the liposomes entrapping the recombinant protein from the free recombinant protein by three successive cycles of PBS washing with centrifugation (20,000 $\times g$, 30 min) at 4 °C.
18. Measure the concentration of entrapped TgPF using a modified Lowry protein assay reagent in the presence of 0.3 % (wt/vol) sodium dodecyl sulfate, using BSA as the standard.
19. Immunize C57BL/6 mice by injecting 40 pmol of TgPF + OML subcutaneously three times at 2-weekly intervals and then challenge the immunized mice with 1×10^3 *T. gondii* PLK tachyzoites via the intraperitoneal route.
20. Record mouse survival rates for 30 days post-infection then sacrifice those that survived. Collect serum, brain, and spleen.
21. Evaluate the level and mechanism of protection by measuring the specific antibodies, survival rates, and parasite burdens generated (*see Notes 17 and 18*) in the brain, and cytokine production via spleen cells.

4 Notes

1. The restriction enzyme cutting recognition sites in the primer sets designed for amplification of the target gene must be identical to the recognition sites in the vector plasmid selected for PCR product insertion and subsequent cloning procedures.
2. The pcDNA3.1 plasmid vector is designed for expression of various genes in mammalian cell lines and is a pivotal step in the strategy used for DNA vaccine development.
3. After insertion of the target gene into the plasmid vector, it is necessary to verify the previous steps by double-digestion with the appropriate restriction enzymes and visualizing the restriction enzyme products by agarose gel electrophoresis to confirm the size difference between the digested and non-digested

plasmid inserted with the gene. The successful designation and construction of the plasmid vector should be confirmed by PCR, restriction enzyme, and sequence analysis. The DNA concentration of the vector is measured by spectrophotometry at OD 260 and 280 nm.

4. Harvest transfected HeLa cells to measure their gene expression levels with real-time PCR. Check protein expression in the cells by western blot analysis using specific polyclonal antibodies.
5. The vacant plasmid, pNull (pcDNA3.1 vector without any inserted gene), or the plasmid containing the inserted gene (pAMA1) is affixed to gold particles (1.0 μm diameter, Bio-Rad Laboratories, USA) using 2 μg of DNA per 1 mg of gold by the addition of 1 M CaCl_2 in the presence of 0.05 M spermidine. Plasmid DNA-coated gold particles are vehicled onto gold-coat tubing in the presence of polyvinylpyrrolidone (360,000 MW) at a concentration of 0.05 mg/ml. Delivery of plasmid DNA-coated gold particles into the mice (bare abdomen) is achieved using a Helios gene gun (Bio-Rad Laboratories, Hercules, CA, USA) at a helium discharge pressure of 400 psi. Two shots are delivered to each mouse.
6. Mouse survival rates are recorded by observing the total number of mice succumbing to infection in relation to the total number of mice in each group. Mice are observed twice daily from 1 to 30 days post-infection.
7. Next, 50 μl of TgAMA1 recombinant protein (adjusted to 5 $\mu\text{g}/\text{ml}$ with coating buffer) is applied to ELISA plate wells (Nunc, Roskilde, Denmark) and incubated overnight at 4 $^\circ\text{C}$. The plate is washed twice with washing buffer and then blocked with PBS containing 3 % skimmed milk (PBS-SM) for 1 h at 37 $^\circ\text{C}$. After washing the plate twice, 50 μl of the test serum samples, and the positive and negative control samples (diluted 1:100 with PBS-SM) are added to the plate. The plate is then incubated at 37 $^\circ\text{C}$ for 1 h and a further six washes are performed, after which the plate is incubated with HRP-conjugated goat anti-mouse IgG diluted 1:4000 with PBS-SM at 37 $^\circ\text{C}$ for 1 h. After six additional washes, 100- μl aliquots of the substrate solution are added to each well of the plate. The absorbance at 415 nm is measured with an ELISA plate reader after 1 h incubation in the dark at room temperature.
8. Cytokine production levels are measured in the culture supernatant of splenocytes stimulated with antigen after 48 h incubation at 37 $^\circ\text{C}$ in a CO_2 incubator.
9. The following sandwich ELISA method is used to measure cytokine levels in the culture supernatant: Dilute the capture

antibody in coating buffer at a dilution of 1:250 then coat the well with 100 μ l of it and keep the remainder overnight. The following day, wash the plate twice with $1\times$ PBST and block with 5 % FBS in PBS and incubate at room temperature for 1 h. After a further two washes, apply the test samples and standards and incubate as described previously, but for 2 h. Wash the plate six times then add 100 μ l of the working detector solution containing the detection antibody and HRP. After a further six washes, the substrate solution is added to each well and the plate is kept in the dark for 30 min before adding the stop solution and taking measurements at 450 nm with an ELISA reader.

10. *T. gondii* (PLK strain) should be maintained in Vero (African green monkey kidney epithelial) cells cultured in EMEM supplemented with 8 % heat-inactivated FBS and 1 % streptomycin-penicillin. Infected and non-infected cells are incubated at 37 °C in 5 % CO₂.
11. After addition of TRI reagent to the purified parasite pellet, the RNA should be extracted as carefully as possible by addition of chloroform followed by vigorous shaking resulting in the formation of three layers (upper aqueous phase for RNA, interphase for DNA, and a lower red-colored phase that contains proteins and lipids). Careful removal of only the RNA layer is essential to the success of the subsequent experiment. It is inverted to mix and then left to sit for 10 min at room temperature.
12. Brief centrifugation of all the SuperScript® First-Strand Synthesis System for RT-PCR reagents and measurements of the RNA concentration just prior to the start of cDNA synthesis should be implemented.
13. Adjustment of the solution to obtain the optimal conditions for digestion with the restriction enzymes is necessary for successful cloning. Use of an appropriate buffer for each enzyme (e.g. buffer H) is important for providing favorable conditions for optimal restriction enzyme activity. Incubation times and temperatures are additional factors that should be taken into consideration. Overnight incubation at 37 °C has been found to be optimal for TgPF and pGEX-4T1 vector digestion with *Eco*RI and *Xho*I enzymes.
14. Profilin expression can be accomplished at 37 °C for 8 h after induction with 1 mM IPTG. The resulting *E. coli* cells are harvested by TNE and high speed centrifugation (10,000 $\times g$ /4 °C/30 min), lysed with 1 % Triton in PBS and 50 mg/ml lysozyme, sonicated on ice (2 pulses/20 amplitude/6 min) then centrifuged as described in the previous step. The supernatant is purified with Glutathione–Sepharose 4B beads. The supernatant–beads mixture is incubated over-

night at 4 °C with rotation, after which the GST-fused protein is eluted with thrombin to remove the GST-tag. The protein obtained is dialyzed in PBS.

15. To visualize protein expression, different samples should be run on SDS-PAGE. This should include IPTG-induced and non-induced samples of the *E. coli* culture supernatant and sediment before and after sonication. The solubility and purity of the expressed protein can be confirmed by visualizing a large single band in the appropriate lane.
16. Oligomannose-coated liposomes have been shown to be a highly safe adjuvant for inducing cellular immunity against entrapped antigens. Because they are composed of Man5-DPPE, which induces delayed hypersensitivity to the entrapped antigen, skin necrosis does not occur at the injection site [24, 25].
17. Cytokine levels are measured in the culture supernatant of splenocytes stimulated with antigen at different incubation times, after 24 h for IFN- γ and after 48 h for IL-4 and IL-10.
18. At 30 days post-challenge, DNA is obtained from samples taken from the surviving mice. Cerebral homogenized tissues are obtained after passing the brain through BioMasher (Nippi. Inc. Tokyo, Japan) and adding 1 ml of TRI Reagent with thorough mixing. For phase separation, 0.2 ml of chloroform is added with vigorous shaking. After 10 min, the mixture is centrifuged at $12,000 \times g$ for 15 min and three layers will be formed. The upper layer containing the RNA is carefully removed and 0.3 ml of absolute ethanol is added to allow DNA precipitation by centrifugation. The precipitated DNA pellet is washed with 0.1 M trisodium citrate in 10 % ethanol, then resuspended in 75 % ethanol and centrifuged at $2000 \times g$ for 5 min. The supernatant is discarded, the pellet allowed to dry at room temperature under a vacuum, after which it is dissolved by adding 8 mM NaOH, and then centrifuged to obtain the supernatant, which is transferred to new tube. To optimize the DNA solution for PCR amplification, 2 mM EDTA and an equal amount and 0.1 M HEPES is added. *T. gondii* B1 gene-specific primers (5'-AAC GGG CGA GTA GCA CCT GAG GAG-3' and 5'-TGG GTC TAC GTC GAT GGC ATG ACA AC-3') are used to amplify the parasite DNA. The PCR mixture (25- μ l total volume) should contain 12 μ l of SYBR-Green PCR master mix, 0.5 μ l of the forward and reverse primers, and 12.5 μ l (50 ng) of genomic DNA. Amplification is performed using a standard protocol (2 min at 50 °C, 10 min at 95 °C, 40 cycles at 95 °C for 15 s, and 60 °C for 1 min) (Applied Biosystems).

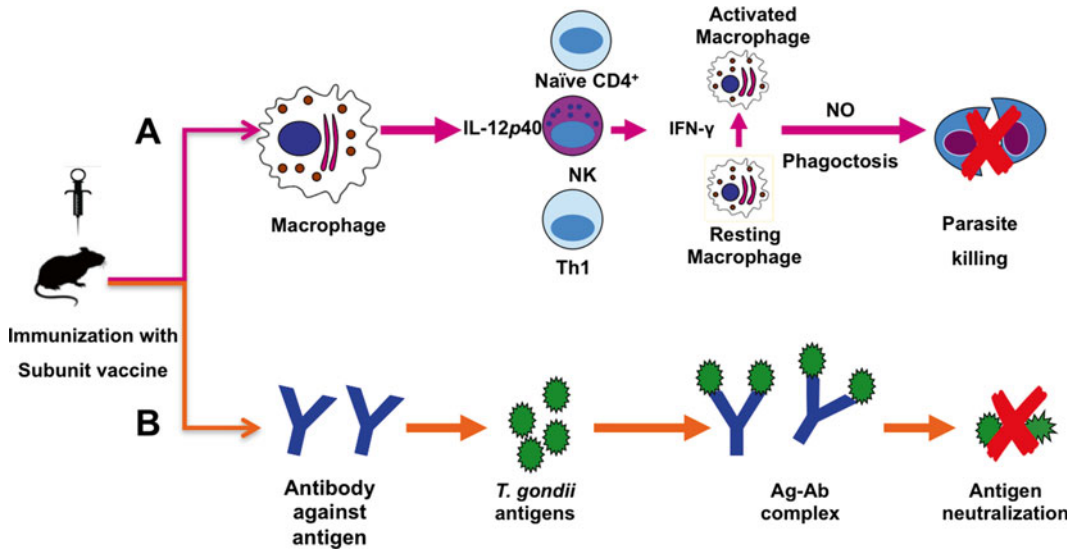

Fig. 1 A potent vaccine against toxoplasmosis should primarily elicit cellular immunity resulting in interferon- γ production, which, as shown in panel A, is considered a key factor for combating the infection. Additionally, as illustrated in panel B, the ability of an antigen to generate specific antibodies post-immunization is particularly beneficial when the antigen plays a role in invasion and induction of pathogenicity

Acknowledgement

The first author has been supported by the Egyptian Ministry of High Education and Scientific Research.

References

- Kravetz JD, Federman DG (2005) Toxoplasmosis in pregnancy. *Am J Med* 118:212–216
- Tenter AM, Heckeroth AR, Weiss LM (2000) *Toxoplasma gondii*: from animals to humans. *Int J Parasitol* 30:1217–1258
- Montoya JG, Liesenfeld O (2004) Toxoplasmosis. *Lancet* 363:1965–1976
- Elmore SA, Jones JL, Conrad PA, Patton S, Lindsay DS, Dubey JP (2010) *Toxoplasma gondii*: epidemiology, feline clinical aspects, and prevention. *Trends Parasitol* 4:190–196
- Sullivan WJ Jr, Jeffers V (2012) Mechanisms of *Toxoplasma gondii* persistence and latency. *FEMS Microbiol Rev* 36:717–733
- Kur J, Holec-Gasior L, Hiszczyńska-Sawicka E (2009) Current status of toxoplasmosis vaccine development. *Expert Rev Vaccines* 6:791–808
- Innes EA, Bartley PM, Maley S, Katzer F, Buxton D (2009) Veterinary vaccines against *Toxoplasma gondii*. *Mem Inst Oswaldo Cruz* 104:246–251
- Rodríguez JB, Szajman SH (2012) New antibacterials for the treatment of toxoplasmosis; a patent review. *Expert Opin Ther Pat* 22:311–333
- Paquet C, Yudin MH (2013) Toxoplasmosis in pregnancy: prevention, screening and treatment. *J Obstet Gynaecol Can* 35:78–81
- Dautu G, Munyaka B, Carmen G, Zhang G, Omata Y, Xuenan X, Igarashi M (2007) *Toxoplasma gondii*: DNA vaccination with genes encoding antigens MIC2, M2AP, AMA1 and BAG1 and evaluation of their immunogenic potential. *Exp Parasitol* 116:273–282
- Döşkaya M, Kalantari-Dehaghi M, Walsh CM, Hiszczyńska-Sawicka E et al (2007) GRA1 protein vaccine confers better immune response compared to codon-optimized GRA1 DNA vaccine. *Vaccine* 25:1824–1837
- Wang PY, Yuan ZG, Petersen E, Li J et al (2012) Protective efficacy of a *Toxoplasma gondii* rhoptry protein 13 plasmid DNA vaccine in mice. *Clin Vaccine Immunol* 19:1916–1920

13. Gong P, Huang X, Yu Q, Li Y et al (2013) The protective effect of a DNA vaccine encoding the *Toxoplasma gondii* cyclophilin gene in BALB/c mice. *Parasite Immunol* 35:140–146
14. Hassan IA, Wang S, Xu L, Yan R, Song X, Li X (2014) DNA vaccination with a gene encoding *Toxoplasma gondii* deoxyribose phosphate aldolase (TgDPA) induces partial protective immunity against lethal challenge in mice. *Parasit Vectors* 7:431
15. Golkar M, Shokrgozar MA, Rafati S, Musset K et al (2007) Evaluation of protective effect of recombinant dense granule antigens GRA2 and GRA6 formulated in monophosphoryl lipid A (MPL) adjuvant against *Toxoplasma* chronic infection in mice. *Vaccine* 25:4301–4311
16. Huang X, Li J, Zhang G, Gong P, Yang J, Zhang X (2012) *Toxoplasma gondii*: protective immunity against toxoplasmosis with recombinant actin depolymerizing factor protein in BALB/c mice. *Exp Parasitol* 130:218–222
17. Zheng B, Lu S, Tong Q, Kong Q, Lou D (2013) The virulence-related rhoptry protein 5 (ROP5) of *Toxoplasma gondii* is a novel vaccine candidate against toxoplasmosis in mice. *Vaccine* 31:4578–4584
18. Wang HL, Li YQ, Yin LT, Meng XL, Guo M et al (2013) *Toxoplasma gondii* protein disulfide isomerase (TgPDI) is a novel vaccine candidate against toxoplasmosis. *PLoS One* 8:8
19. Flori P, Tardy L, Jacquet A, Belleste B, Hafid J, Raberin H, Tran Manh Sung R (2006) Effect of rSAG-1(P30) immunisation on the circulating and tissue parasites in guinea pigs as determined by quantitative PCR. *Parasitol Res* 98:511–518
20. Chuang SC, Ko JC, Chen CP, Du JT, Yang CD (2013) Induction of long-lasting protective immunity against *Toxoplasma gondii* in BALB/c mice by recombinant surface antigen 1 protein encapsulated in poly (lactide-co-glycolide) microparticles. *Parasit Vectors* 6:34
21. Qu D, Han J, Du A (2013) Enhancement of protective immune response to recombinant *Toxoplasma gondii* ROP18 antigen by ginsenoside Re. *Exp Parasitol* 135:234–239
22. Yu L, Yamagishi J, Zhang S, Jin C, Aboge GO, Zhang H, Zhang G, Tanaka T, Fujisaki K, Nishikawa Y, Xuan X (2012) Protective effect of a prime-boost strategy with plasmid DNA followed by recombinant adenovirus expressing TgAMA1 as vaccines against *Toxoplasma gondii* infection in mice. *Parasitol Int* 61:481–486
23. Tanaka S, Kuroda Y, Ihara F, Nishimura M, Hiasa J, Kojima N, Nishikawa Y (2014) Vaccination with profilin encapsulated in oligomannose-coated liposomes induces significant protective immunity against *Toxoplasma gondii*. *Vaccine* 32:1781–1785
24. Fukasawa M, Shimizu Y, Shikata K, Nakata M, Sakakibara R, Yamamoto N, Hatanaka M, Mizuochi T (1998) Liposome oligomannose-coated with neoglycolipid, a new candidate for a safe adjuvant for induction of CD8+ cytotoxic T lymphocytes. *FEBS Lett* 441:353–356
25. Shimizu Y, Takagi H, Nakayama T, Yamakami K, Tadakuma T, Yokoyama N, Kojima N (2007) Intraperitoneal immunization with oligomannose-coated liposome-entrapped soluble leishmanial antigen induces antigen-specific T-helper type immune response in BALB/c mice through uptake by peritoneal macrophages. *Parasite Immunol* 29:229–239

Chapter 11

DNA Vaccination in Chickens

Shishir Kumar Gupta, Sohini Dey, and Madhan Mohan Chellappa

1 Introduction

Proper health management of birds is very crucial for successful development of the poultry sector. A number of infectious diseases affect birds and cause a potential threat to the industry in the form of huge economic losses. Vaccination of the birds against the infectious diseases is widely followed; however, conventional vaccines have certain disadvantages [1]. With the advancement in the recombinant DNA technology, new-generation vaccines have emerged as a safer replacement to the conventional vaccines. DNA vaccines, which contain gene(s) encoding for one or more than one antigenic proteins, offer many advantages over conventional vaccines. In DNA vaccine, the expression of antigens in the target host resembles native pathogen epitopes more closely, and thus preserves the protein structure and antigenicity than the conventional vaccines [2–4]. Further, DNA vaccines are able to efficiently stimulate both humoral and cellular immune responses to protein antigens, and thus effective against a wide range of pathogens [5]. However, success of DNA vaccination in birds depends on many factors apart from their efficacy. They have to be relatively less expensive, easy to administer, and stable under field conditions. Moreover, as poultry are food animals as well, it is undesirable to have vaccine residues in the relevant tissues. This has been avoided by the use of subcutaneous or intradermal routes instead of intramuscular route [6].

The plasmid vectors are easy to construct and can be produced in large quantities quickly and affordably than conventional vaccines. In addition, only a small quantity (micrograms) of plasmid vector can deliver several antigens in a single shot, which provide immunity against many pathogens at once. All these factors significantly

reduce the expenses incurred by vaccination [7, 8]. The effectiveness of DNA vaccines can be further enhanced by the inclusion of the molecular adjuvants such as TLR (Toll-like receptor) ligands and cytokines. Notable examples of TLR ligands include CpG (TLR21) and flagellin (TLR5) and cytokines such as IL-12 and IFN- γ . A number of studies have reported upregulation of the immune response when TLR ligands and cytokines were given along with a DNA vaccine [3, 9–13].

1.1 Advantages of DNA Vaccines

1. The production of DNA vaccine is easy, rapid, and economical as compared to conventional vaccines.
2. The DNA vaccine is more thermostable than traditional vaccines; hence, maintenance of a cold chain is not required.
3. It eliminates the risk of reversion of pathogenic phenotypes.
4. DNA vaccines present antigen to both MHC-I and MHC-II molecules.
5. The immune response elicited by DNA vaccine is directed against only the antigen of interest.
6. Cost-effectiveness and ease of development.
7. DNA vaccines mimic a natural infection. Antigenic protein closely resembles the normal eukaryotic structure and undergoes post translational modifications.

1.2 Important Poultry Infectious Diseases and DNA Vaccine Antigens

Poultry suffers from a number of infectious diseases, including Newcastle disease (ND), Infectious bursal disease (IBD), Infectious bronchitis (IB), Avian Influenza (AI), and *Eimeria* sp. Both inactivated and live vaccines are widely used against these diseases, but these vaccines are associated with their inherent disadvantages [1, 3, 4]. A number of studies have shown that DNA vaccines are efficacious in conferring protection against infectious diseases in chickens. Further, as a DNA vaccine encodes antigenic protein(s) in the absence of the live pathogen, it helps in avoiding the occurrence of problems associated with reverted virulence, divergent mutants and reduces environmental contamination [13]. The antigenic protein encoding pathogen genes which have been used in the chicken DNA vaccines are given in Table 1 along with molecular adjuvants that were used to enhance the efficacy of the vaccines.

1.3 Points to Consider before Selecting a Vaccine Antigen

The selection of a gene of interest (vaccine gene) is a crucial aspect before construction of a DNA vaccine as it affects the type of immune response (humoral or cell mediated) induced. In case, where neutralizing antibodies are needed to prevent the occurrence of an infection, most appropriately, a surface antigen is selected. DNA vaccines designed to treat an established infection need to have an antigen that induce a potent cell mediated immune (CMI) response. In such cases, infecting pathogens have intracel-

Table 1
Protective antigens as DNA vaccine candidates

Pathogen	DNA vaccine candidate(s)	Adjuvant(s)	References
Newcastle disease virus	HN, F	IFN- γ , IL-4	[14–16]
Infectious bursal disease virus	VP2, Polyprotein VP2-4-3	IL-2, CpG, IFN- γ , IL-6, Truncated Hsp70 of <i>Mycobacterium tuberculosis</i>	[17–23]
Infectious bronchitis virus	S1 glycoprotein, nucleocapsid protein, M protein	IL-2, GM-CSF	[24–27]
Avian influenza virus	HA, NA	MDP-1, Esat-6	[28–34]
Chicken infectious anemia virus	VP1, VP2	HMGB1 Δ C	[35, 36]
<i>Eimeria acervulina</i>	3-1E, cSZ-2	IL-8, IL-15, IL-2, IFN- γ	[3, 37–39]
<i>Eimeria tenella</i>	EtMIC2, 5401, TA4	IL-2	[40–42]
Colibacillosis	(K88) FaeG	IL-6	[43]

lular life cycle and, hence, humoral immune response will not be effective to eliminate the infection. The antigens selected for this purpose are the ones which are expressed intracellularly during infection. Such antigens are processed inside the cell and presented to major histocompatibility molecules for the generation of CMI response. For example, cellular immunity is essential in Newcastle disease virus (NDV) infection as viral pathogenesis includes an intracellular stage [13, 44].

1.4 Strategies to Enhance the Protein Expression from a DNA Vector

This can be achieved by the following methods:

1. Placing Kozak sequence (GCCRCCATGG) upstream to the gene in such a way that, if possible, it includes start codon of the gene [45].
2. Check if 5' untranslated (UTR) region contains ATG codons, they can be removed [46].
3. Placing an intron in front of the gene further enhances the rate of transcription.
4. Codon optimization without altering the protein sequence can enhance the rate of translation [46].
5. The efficiency of the DNA uptake following DNA vaccination is not very efficient; hence, to enhance the DNA uptake various formulations have been used. Formulating DNA vaccine in microparticles or liposomes has been reported to increase the uptake of plasmid DNA by cells in animal models [47].

1.5 Enhancing Immunogenicity of the DNA Vaccine

1. Immunogenicity of the DNA vaccine can be augmented by incorporating coding sequences for the peptide epitopes as opposed to the full coding sequence.
2. Inclusion of sequence coding for cytokines such IL-12 and granulocyte–macrophage colony-stimulating factor (GM-CSF) which can enhance CTL responses [48].
3. Plasmid encoding IL-2 improves overall efficacy while interferon (IFN)- γ enhances Th1 type responses.
4. Humoral responses are enhanced by including coding sequences of IL-4, IL-5 and IL-10.
5. Inclusion of TLR (Toll-like receptor) ligands such flagellin (TLR5), Poly I:C (TLR3) and CpG (TLR21) can substantially enhance the immune responses [13].

2 Materials Required

2.1 For Cloning

1. DNA or plasmid containing the gene of interest.
2. RNA isolation and cDNA synthesis kit.
3. Gene specific primers for amplification by polymerase chain reaction (PCR).
4. PCR cloning kit.
5. A cloning vector (pTZ 57R/T) for cloning and sequencing of the vaccine gene.
6. Restriction enzymes, T4 DNA ligase, 10 \times buffers.
7. Suitable eukaryotic expression vector (e.g., pcDNA3.1, pCI).
8. Agarose, loading dye, and nucleic acid stain (ethidium bromide) suitable for gel electrophoresis.
9. Agarose gel electrophoresis system.
10. UV spectrophotometer.
11. Gel extraction kit (Qiagen).
12. Competent *E. coli* (DH5 α) cells for the propagation of the plasmid vector. Competent *E. coli* cells can be made following standard Sambrook protocol.
13. SOC media.

To prepare 1000 ml SOC—add the following to 900 ml of distilled H₂O: 20 g Bacto tryptone, 5 g Bacto yeast extract, 2 ml of 5 M NaCl, 2.5 ml of 1 M KCl, 10 ml of 1 M MgCl₂, 10 ml of 1 M MgSO₄, 20 ml of 1 M glucose. Adjust to 1 l with distilled H₂O (dH₂O) and sterilize by autoclaving.

14. LB agar plate with appropriate antibiotic for selection of transformed colonies.

To make 1000 ml of LB agar—add the following to 800 ml dH₂O: 10 g Bacto tryptone, 5 g yeast extract, 10 g NaCl.

Adjust pH to 7.5 with NaOH. Add 15 g agar, melt agar into solution in a microwave oven. Adjust volume to 1 l with dH₂O and sterilize by autoclaving.

15. Incubator for the growth of plates.

2.2 Recombinant Clone Selection

1. LB medium—add the following to 800 ml dH₂O: 10 g Bacto tryptone, 5 g yeast extract, 10 g NaCl. Adjust pH to 7.5 with NaOH. Make final volume to 1 l with dH₂O and sterilize by autoclaving.
2. Sterile inoculation loop.
3. Sterile tubes.
4. Shaker incubator.
5. Plasmid isolation kit (Qiagen).
6. Restriction enzymes to confirm the clone.
7. Agarose, loading dye, DNA molecular ladder, and ethidium bromide stain.
8. Agarose gel electrophoresis system, UV spectrophotometer.

2.3 Confirmation of Protein Expression

1. Cell line for transfection of the expression vector (CHO, HEK).
2. Appropriate growth medium (e.g., DMEM) with serum or growth factors or both.
3. Opti-MEM media, transfection agent (Lipofectamine 2000), fetal bovine serum (FBS), PBS, 6-well plates.
4. A positive control (GFP cloned into the expression vector).
5. Specific primary antibody to the antigenic protein.
6. Secondary conjugated antibody against the primary antibody.
7. Materials for Western blotting and/or immunofluorescence.
8. Molecular adjuvants

2.4 Inoculation of Plasmid

1. High quality endotoxin free plasmid DNA.
2. Needles (18- and 27-Gauge) and tuberculin syringes.
3. Phosphate-buffered saline (PBS): 0.01 M Na₂HPO₄/KH₂PO₄, 0.15 M NaCl/KCl, pH 7.3 (8 g NaCl, 0.2 g KCl, 1.15 g Na₂HPO₄, 0.2 g KH₂PO₄ per liter).

2.5 Evaluation of Humoral Immunity

1. An enzyme-linked immunosorbent assay (ELISA) reader.
2. Coating buffer: 100 mM Na₂CO₃/NaHCO₃, pH 9.5 for ELISA.
3. PBST (PBS with 0.05 % Tween 20).
4. HRP conjugated secondary antibody, substrate [100 mM citrate phosphate solution containing 1 mg/ml *o*-phenylenediamine (OPD) and 1 μl H₂O₂].
5. Reaction stop solution (50 μl of 8 N H₂SO₄).

2.6 Evaluation of Cellular Immunity (Lymphocyte Proliferation Test and ELISPOT)

1. Vacutainer tubes with anticoagulant.
2. Hemocytometer, 96-well microtiter plate.
3. Trypan blue dye.
4. Ficoll-Hypaque solution.
5. RPMI-1640, PBS, pen-strep, FBS, Con A.
6. MTT dye (3-(4,5-dimethylthiazol-2-yl)-2,5-diphenyl-tetrazoliumbromide).
7. DMSO (dimethyl sulfoxide).
8. ELISA reader.
9. 96-well nitrocellulose plates.
10. RBC lysis buffer. 10× RBC Lysis Buffer: 90 g NH₄Cl (0.155 M), 10 g KHCO₃ (0.01 M), 370 mg EDTA (0.1 mM). Dissolve in 1 l of ddH₂O and filter through a 0.22 µm filter.
11. Chicken IFN-γ specific antibody.
12. Bovine serum albumin (BSA).
13. Appropriate secondary conjugated antibody (Biotinylated).
14. Streptavidin-alkaline phosphatase, substrates nitro-blue tetrazolium (NBT) and 5-bromo-4-chloro-3'-indolyl phosphate.

3 Procedure

3.1 Construction, Production, and Purification of the Plasmid Vector

Plasmid vector for expression of the gene of interest mostly contain human cytomegalovirus virus promoter (HCMV), like pcDNA3.1 and pCI; however, other promoters such as Rou sarcoma virus long terminal repeat (LTR) is also being used though it drives a weaker expression than HCMV promoter. Vaccine gene having start and stop codon is being inserted downstream to the promoter sequence followed by a polyadenylation sequence at its 3' end (Fig. 1).

1. Obtain vaccine gene either from other cloned plasmid or from DNA sequence by PCR amplification. When the vaccine gene is not available, but its sequence is known, cDNA is generated from the virus infected tissue that expresses high levels of the gene. Primers used for this purpose should have suitable restriction sites (directional cloning). Use proofreading polymerases to eliminate the chances of sequence modifications.
2. Purify the amplicon and digest it with the specific restriction enzymes. Cut the plasmid vector with the same restriction enzymes.
3. Load the restriction digested vector and insert on an agarose gel.

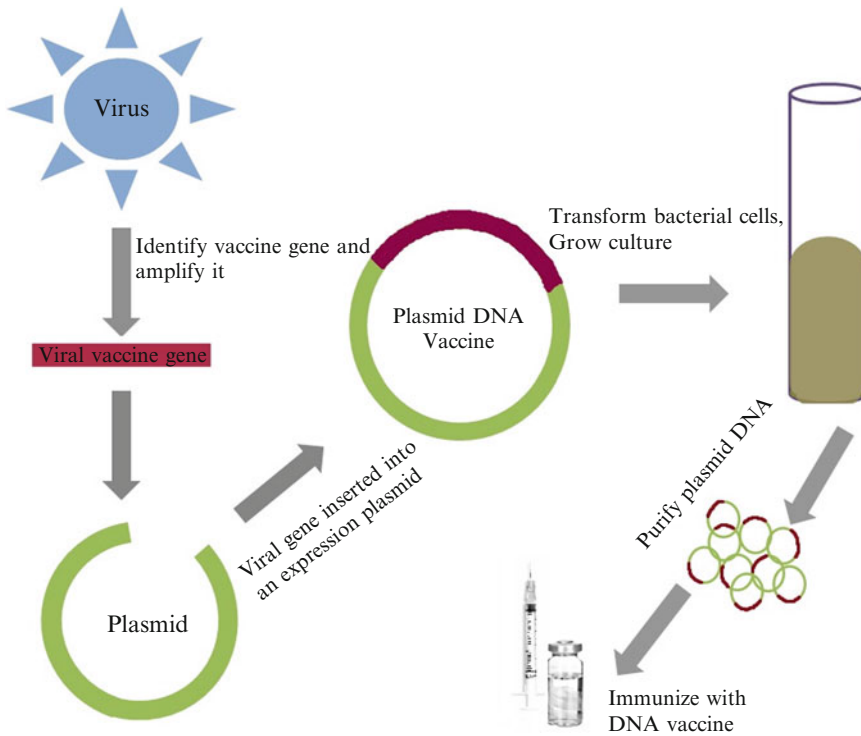

Fig. 1 An overview of design, construction, and production of a DNA vaccine

4. Resolve and gel purify the insert and vector fragments using the Qiagen gel purification kit. Measure the concentration of the vector and insert elutes.
5. Set up ligation reaction. Usually a molar ratio of 1:3 (vector to insert) is chosen.

For a typical 10 μl reaction (containing equimolar concentrations of vector and insert):

Vector:	2 μl
Insert:	6 μl
10 \times ligase buffer:	1 μl
T4 DNA ligase:	0.5 μl
DW:	0.5 μl

6. Incubate the ligation mixture overnight at 16 $^{\circ}\text{C}$.
7. Take out the competent *Escherichia coli* (DH5 α) cells from deep freezer and thaw it on ice.

8. Add 1–5 μl of the ligation mixture to the 50 μl of the competent cells. Gently mix by flicking the bottom of the tube with finger. Keep for 30 min on ice.
9. Transform the cells. Give a brief heat shock by placing the bottom 1/2 to 2/3 of the tube into a 42 °C water bath for 30–60 s (45 s is usually ideal, but this varies depending on the competent cells).
10. Place the tube back on ice for 2 min.
11. Add 500 μl of SOC media (without antibiotic) and grow in a 37 °C shaking incubator for 60 min.
12. Spread 50–100 μl of transformation growth onto an agar plate containing the appropriate antibiotic.
13. Grow the transformed culture overnight at 37 °C in an incubator.

3.2 Recombinant Clone Selection

1. Using sterile inoculation loops, pick each colony and aseptically inoculate each into a 6 ml culture of Luria–Bertani (LB) medium with appropriate antibiotic in a 15 ml tube.
2. Grow overnight in LB medium at 37 °C in a shaking incubator for 12–15 h.
3. Plasmid is isolated from the culture with a plasmid isolation kit (Qiagen).
4. Check for the presence of gene of interest by restriction digestion and by sequencing of the plasmid DNA region having the gene of interest.
5. Assess the purity and concentration of the plasmid DNA by determining the ratio of absorbance at 260 nm over 280 nm (~1.8).
6. Grow a culture of the confirmed clone to isolate plasmid for in vitro and in vivo testing.
7. High quality plasmid (low endotoxin) DNA may be bulk purified by using a purification kit (Qiagen).

3.3 In Vitro Confirmation of Protein Expression

The expression of the DNA vaccine construct is verified in vitro before it could be used in vivo by transient transfection studies in a suitable cell line. The most commonly used cell lines for this purpose include HEK (Human embryonic kidney) and COS-7 (Monkey kidney fibroblasts) cell lines which offer high transfection efficiencies and, hence, greater protein expression.

1. Cells are grown in a suitable medium supplemented with 10 % fetal bovine serum (FBS).
2. When cells reach 50–70 % confluency, transfect the DNA.
3. For a 6-well plate, add 4 μg of plasmid in 150 μl of Opti-MEM. In another vial, dilute 10 μl of Lipofectamine™ 2000

(Invitrogen) reagent and keep at room temperature for 5 min (*see Note 1*).

4. Mix the contents of both the vials and allow to stand at room temperature for 25–30 min.
5. After the incubation period, add the complex drop by drop to the cells. Media can be changed after 5–6 h.
6. Use a positive control such as GFP cloned downstream to the promoter to monitor its activity in the cells.
7. Harvest the cells and supernatant after a stipulated period of time (1–3 days).
8. Presence of expressed foreign protein either in cells or in supernatant may be determined by the following methods (*see Note 2*):
 - (a) Western blotting.
 - (b) Immunofluorescence.
 - (c) Immunoprecipitation after radiolabeling the cells.
 - (d) Enzyme-linked immunosorbent assay (ELISA).
 - (e) Fluorescence-activated cell sorting (FACS) analysis.

3.4 In Vivo Immunization

1. Procure specific pathogen free chickens (SPF).
2. Divide birds at 14 days of age into different groups depending on the study including suitable controls.
3. Birds are immunized with about 100 µg of plasmid either by subcutaneous or intramuscular route twice at 2 weeks interval with the help of 1 ml tuberculin syringes with attached 27 G 3/4" needle.

3.5 Evaluation of Humoral and Cellular Response

3.5.1 Humoral Response

Humoral immune response can be evaluated in many ways including ELISA, B-cell ELISPOT assay, and Neutralization assay. The most frequent and convenient way of measuring specific antibody immune response is ELISA which can also be used to quantify the response [49, 50].

Antibody levels in pre- and post-immunization serum sample are quantified by ELISA as follows:

1. The serum samples from immunized and control groups are collected at different intervals (0, 7, 21, and 28 days) post immunization and tested for the vaccine antigen specific antibodies.
2. Coat the 96-well microtiter plate with vaccine antigen in the coating buffer (100 mM bicarbonate buffer, pH 9.5) at 4 °C overnight.
3. Wash the plate next day and block with 2 % bovine serum albumin (BSA).
4. Collect sera at different intervals and add in the respective wells (1:100).

5. Incubate the plate at 37 °C for 1 h.
6. After incubation, wash the plate with PBS-T thrice and incubate with HRP conjugated secondary antibody (1:3000) at 37 °C for 1 h (*see Note 3*).
7. Wash the plate and add substrate solution [100 mM citrate phosphate solution containing 1 mg/ml *o*-phenylenediamine (OPD) and 1 µl H₂O₂].
8. Stop the reaction after 30 min with 50 µl of 8 N H₂SO₄.
9. Measure the absorbance at 490 nm in an ELISA reader.

3.5.2 Evaluation of Cell Mediated Immune Response

Cell mediated immune response can be measured by Lymphocyte transformation assay (LTT) and cytokine ELISPOT assay. In response to specific antigen, lymphocytes proliferate which indicates the specificity of the lymphocytes to the particular antigen. Cytokine ELISPOT assay detects the cytokines secreted by the lymphocytes in response to the specific antigen [51, 52].

Lymphocyte Transformation Test (LTT)

1. Collect the blood from chicken in sterile syringe having an anticoagulant (EDTA) and layer it over Ficoll-Hypaque with density 1.077 g/ml.
2. After centrifugation at 1000×*g* for 45 min, collect the interface containing the PBMCs and wash twice with PBS.
3. Resuspend PBMCs in RPMI-1640 media containing 10 % FBS and 1 % pen-strep.
4. Determine the cell viability by trypan blue dye exclusion method.
5. Adjust the cell concentration to 1 × 10⁷ cells/ml.
6. Plate 100 µl of the cell suspension in triplicate into 96-well plates.
7. Add 100 µl of the media containing either vaccine antigen (50 µg/ml) or ConA (10 µg/ml) into wells.
8. Incubate the plate at 37 °C in 5 % CO₂ for 2 days.
9. After 2 days of incubation, add 20 µl of 5 mg/ml MTT dye (3,4,5-dimethylthiazol-2-yl-2,5-diphenyl-tetrazoliumbromide) to each well.
10. Incubate the plate for another 4 h.
11. Dissolve the formazan crystal formed in 100 µl of DMSO.
12. Take the optical density (OD) readings on microplate ELISA reader at an absorbance of 495 nm.
13. The proliferative response for the assay is expressed as stimulation index (SI), calculated by dividing the mean OD of the stimulated cultures by the mean OD of unstimulated control cultures.

ELISPOT Assay

1. Spleen tissue is collected from the immunized chickens and placed in Hank's balanced salt solution (HBSS) (140 mM NaCl, 5 mM KCl, 2.5 mM CaCl₂, 1.1 mM MgCl₂, 5.6 mM glucose, and 10 mM HEPES, pH 7.4).
2. Make single cell suspension by squeezing it through 70 µm mesh or 5-ml syringe plunger in RPMI-1640 media supplemented with FBS.
3. Centrifuge and resuspend in RBC lysis buffer at room temperature for 5 min (*see Note 4*).
4. Wash twice with HBSS and resuspend in RPMI-1640 with 5 % FBS, 2 mM GlutaMAX-I, 50 mM β-mercaptoethanol, 100 U/ml penicillin, and 100 µg/ml streptomycin sulfate.
5. Determine the cell viability by trypan blue method and adjust the cell concentration to 1×10^6 /ml.
6. Coat plate with anti-chicken IFN-γ antibody (5 µg/ml) in coating buffer (sodium bicarbonate, 50 mM, pH 9.6) and incubate overnight at 4 °C.
7. Wash the plate thrice with PBS-T (140 mM NaCl, 5 mM KCl, 10 mM Na₂HPO₄, 1 mM KH₂PO₄, and 0.05 % (v/v) Tween 20, pH 7.2).
8. Block the plates with blocking solution (1 % BSA) for 1 h at 41 °C in 5 % CO₂.
9. Discard the blocking buffer and seed splenocytes at a cell density of 2×10^5 to 3×10^5 /100 µl to triplicate wells.
10. Cells are incubated with either in the presence of media alone or with recombinant vaccine antigen to a final volume of 200 µl per well for 24 h at 41 °C in 5 % CO₂ incubator.
11. After incubation, wash the plate twice with dH₂O and thrice with PBS-T.
12. Dilute biotinylated secondary antibody (1 µg/ml) specific to chicken IFN-γ in PBS-T and 1 % BSA (blocking buffer) and add 100 µl/well for 1–2 h at room temperature.
13. Incubate plate with streptavidin-alkaline phosphatase (2 µg/ml) (in blocking buffer for 1 h at room temperature).
14. Wash the plate three to five times and develop the color by adding substrate NDB/BCIP and wait for the spots to appear.
15. Let the plate dry and count the spots with a stereoscope.
 - Humoral and cell mediated immune response may also be estimated at transcription level by quantifying cytokines mRNA levels by real-time PCR (*see Note 5*).

3.6 Challenge Study (Determination of Protection from Challenge)

1. To further test the efficacy of the DNA vaccine, immunized birds may be challenged with a virulent strain of the pathogen.
2. After booster dose (second immunization), birds are intra-ocularly challenged with the virulent pathogen.
3. Monitor the birds for the next few days (10 days) for clinical signs and symptoms.
4. Protection against challenge is assessed by studying the occurrence of mortality in susceptible birds, presence of pathogen in the tissue, gross lesions, and bursa–body weight ratio.
5. Histological examinations are also done to confirm the protection status.

4 Notes

1. The optimal Lipofectamine–DNA ratio for transfection varies from one cell type to another, and should be determined beforehand to enhance the transfection efficiency. Also, use of other transfection agents may enhance the transfection efficiency.
2. Expression of vaccine gene can also be analyzed at the transcription level through quantifying mRNA levels by Real-time PCR.
3. The optimal dilutions of the antibody for the use in experiments are provided by the manufacturers, but may have to be determined in some cases depending on the type of experiment.
4. Splenocytes may also be separated by density gradient centrifugation omitting the need of a RBCs lysis step. Spleen tissue is passed through a 70 μm mesh and cells are suspended in the media. Layer the cell suspension over Ficoll and centrifuge. Wash the interface twice with PBS and resuspend the cells in media [52].
5. Both humoral and cellular immune responses may also be analyzed at the transcription level by quantifying mRNA levels of cytokines. The mRNA levels of Th1 and Th2 cytokines such as IFN- γ , IL-12, and IL-4 are quantified by real-time PCR.

References

1. Bowersock TL (2002) Evolving importance of biologics and novel delivery systems in the face of microbial resistance. *AAPS PharmSci* 4:1–7
2. O’Hagan DT, MacKichan ML, Singh M (2001) Recent developments in adjuvants for vaccines against infectious diseases. *Biomol Eng* 18:69–85
3. Min W et al (2001) Adjuvant effects of IL-1beta, IL-2, IL-8, IL-15, IFN-alpha, IFN-gamma TGFbeta4 and lymphotactin on DNA vaccination against *Eimeria acervulina*. *Vaccine* 20:267–274
4. Li K et al (2013) Adjuvant effects of interleukin-18 in DNA vaccination against infectious bursal disease virus in chickens. *Vaccine* 31:1799–1805
5. Donnelly JJ, Ulmer JB, Shiver JW, Liu MA (1997) DNA vaccines. *Annu Rev Immunol* 15:617–648

6. Dhama K, Mahendran M, Gupta PK, Rai A (2008) DNA vaccines and their applications in veterinary practice: current perspectives. *Vet Res Commun* 32:341–356
7. Rao SS et al (2009) A gene-based avian influenza vaccine in poultry. *Poultry Sci* 88:860–866
8. Beard CW, Mason PW (1998) Out on the farm with DNA vaccines. *Nat Biotechnol* 16:1325–1328
9. Van Duin D, Medzhitov R, Shaw AC (2006) Triggering TLR signaling in vaccination. *Trends Immunol* 27:49–55
10. Coban C et al (2011) Novel strategies to improve DNA vaccine immunogenicity. *Curr Gene Ther* 11:479–484
11. Gupta SK et al (2013) Recombinant flagellin and its cross-talk with lipopolysaccharide—effect on pooled chicken peripheral blood mononuclear cells. *Res Vet Sci* 95:930–935
12. Gupta SK, Bajwa P, Deb R, Chellappa MM, Dey S (2014) Flagellin a toll-like receptor 5 agonist as an adjuvant in chicken vaccines. *Clin Vaccine Immunol* 21:261–270
13. Gupta SK, Deb R, Dey S, Chellappa MM (2014) Toll-like receptor-based adjuvants: enhancing the immune response to vaccines against infectious diseases of chicken. *Exp Rev Vaccine* 13:909–925
14. Loke CF, Omar AR, Raha AR, Yusoff K (2005) Improved protection from velogenic Newcastle disease virus challenge following multiple immunizations with plasmid DNA encoding for F and HN genes. *Vet Immunol Immunopathol* 106:259–267
15. Sawant PM et al (2011) Immunomodulation of bivalent Newcastle disease DNA vaccine induced immune response by co-delivery of chicken IFN- γ and IL-4 genes. *Vet Immunol Immunopathol* 144:36–44
16. Zhao K et al (2013) Preparation and efficacy of Newcastle disease virus DNA vaccine encapsulated in PLGA nanoparticles. *PLoS One* 8(12):e82648
17. Chang HC, Lin TL, Wu CC (2001) DNA-mediated vaccination against infectious bursal disease in chickens. *Vaccine* 20:328–335
18. Hulse DJ, Romero CH (2004) Partial protection against infectious bursal disease virus through DNA-mediated vaccination with the VP2 capsid protein and chicken IL-2 genes. *Vaccine* 22:1249–1259
19. Mahmood MS, Siddique M, Hussain I, Khan A, Mansoor MK (2006) Protection capability of recombinant plasmid DNA vaccine containing VP2 gene of very virulent infectious bursal disease virus in chickens adjuvanted with CpG oligodeoxynucleotide. *Vaccine* 24:4838–4846
20. Park JH, Sung HW, Yoon BI, Kwon HM (2009) Protection of chicken against very virulent IBDV provided by in ovo priming with DNA vaccine and boosting with killed vaccine and the adjuvant effects of plasmid-encoded chicken interleukin-2 and interferon- γ . *J Vet Sci* 10:131–139
21. Kumar S et al (2009) Effective protection by high efficiency bicistronic DNA vaccine against infectious bursal disease virus expressing VP2 protein and chicken IL-2. *Vaccine* 27:864–869
22. Sun JH, Yan YX, Jiang J, Lu P (2005) DNA immunization against very virulent infectious bursal disease virus with VP2-4-3 gene and chicken IL-6 gene. *J Vet Med B* 52:1–7
23. Maity HK, Dey S, Mohan CM, Khulape SA, Pathak DC, Vakharia VN (2015) Protective efficacy of a DNA vaccine construct encoding the VP2 gene of infectious bursal disease and a truncated HSP70 of *Mycobacterium tuberculosis* in chickens. *Vaccine* 33:1033–1039
24. Kapczynski DR, Hilt DA, Shapiro D, Sellers HS, Jackwood MW (2003) Protection of chickens from infectious bronchitis by in ovo and intramuscular vaccination with a DNA vaccine expressing the S1 glycoprotein. *Avian Dis* 47:272–285
25. Tang M, Wang H, Zhou S, Tian G (2008) Enhancement of the immunogenicity of an infectious bronchitis virus DNA vaccine by a bicistronic plasmid encoding nucleocapsid protein and interleukin-2. *J Virol Methods* 149:42–48
26. Tan B, Wang H, Shang L, Yang T (2009) Co-administration of chicken GM-CSF with a DNA vaccine expressing infectious bronchitis virus (IBV) S1 glycoprotein enhances the specific immune response and protects against IBV infection. *Arch Virol* 154:1117–1124
27. Yang T et al (2009) Multivalent DNA vaccine enhanced protection efficacy against infectious bronchitis virus in chickens. *J Vet Med Sci* 71:1585–1590
28. Fynan EF, Robinson HL, Webster RG (1993) Use of DNA encoding influenza hemagglutinin as an avian influenza vaccine. *DNA Cell Biol* 12:785–789
29. Qiu M et al (2006) Protection against avian influenza H9N2 virus challenge by immunization with hemagglutinin-or neuraminidase-expressing DNA in BALB/c mice. *Biochim Biophys Res Commun* 343:1124–1131
30. Jiang Y (2007) Enhanced protective efficacy of H5 subtype avian influenza DNA vaccine with codon optimized HA gene in a pCAGGS plasmid vector. *Antiviral Res* 75:234–241

31. Rao S et al (2008) Multivalent HA DNA vaccination protects against highly pathogenic H5N1 avian influenza infection in chickens and mice. *PLoS One* 3(6):e2432
32. Jalilian B et al (2010) Research development of avian influenza virus H5 DNA vaccine and MDP-1 gene of *Mycobacterium bovis* as genetic adjuvant. *Genet Vaccine Ther* 8:4
33. Cherbonnel M, Rousset J, Jestin V (2003) Strategies to improve protection against low-pathogenicity H7 avian influenza virus infection using DNA vaccines. *Avian Dis* 47:1181–1186
34. Oveissi S, Omar AR, Yusoff K, Jahanshiri F, Hassan SS (2010) DNA vaccine encoding avian influenza virus H5 and Esat-6 of *Mycobacterium tuberculosis* improved antibody responses against AIV in chickens. *Comp Immunol Microbiol Infect Dis* 33:491–503
35. Sawant PM et al (2015) Development of a DNA vaccine for chicken infectious anemia and its immunogenicity studies using high mobility group box I protein as a novel immunoadjuvant indicated induction of promising protective immune responses. *Vaccine* 33:333–340
36. Senthil K et al (2004) Development of DNA vaccine against chicken anemia virus simultaneously using its VP1 and VP2 proteins. Paper presented in XII Conference of IPSA and National Symposium, Himachal Pradesh Krishi Vishwavidyalaya, Palampur, p 152
37. Song KD et al (2000) A DNA vaccine encoding a conserved *Eimeria* protein induces protective immunity against live *Eimeria acervulina* challenge. *Vaccine* 19:243–252
38. Ma D et al (2011) Vaccination of chickens with DNA vaccine encoding *Eimeria acervulina* 3-1E and chicken IL-15 offers protection against homologous challenge. *Exp Parasitol* 127:208–214
39. Shah MAA, Song X, Xu L, Yan R, Li X (2011) Construction of DNA vaccines encoding *Eimeria acervulina* cSZ-2 with chicken IL-2 and IFN- γ and their efficacy against poultry coccidiosis. *Res Vet Sci* 90:72–77
40. Ding X et al (2005) In ovo vaccination with the *Eimeria tenella* EtMIC2 gene induces protective immunity against coccidiosis. *Vaccine* 23:3733–3740
41. Du A, Wang S (2005) Efficacy of a DNA vaccine delivered in attenuated *Salmonella typhimurium* against *Eimeria tenella* infection in chickens. *Int J Parasitol* 35:777–785
42. Xu Q et al (2008) Vaccination of chickens with a chimeric DNA vaccine encoding *Eimeria tenella* TA4 and chicken IL-2 induces protective immunity against coccidiosis. *Vet Parasitol* 156:319–323
43. Cho SH, Loewen PC, Marquardt RR (2004) A plasmid DNA encoding chicken interleukin-6 and *Escherichia coli* K88 fimbrial protein FaeG stimulates the production of anti-K88 fimbrial antibodies in chickens. *Poultry Sci* 83:1973–1978
44. Brandsma JL (2006) DNA vaccine design. In: Saltzman MW, Shen H, Brandsma JL (eds) DNA vaccines. Humana, Totowa, NJ, pp 3–10
45. Kozak M (1986) Point mutations define a sequence flanking the AUG initiator codon that modulates translation by eukaryotic ribosomes. *Cell* 44:283–292
46. Nagata T, Uchijima M, Yoshida A, Kawashima M, Koide Y (1999) Codon optimization effect on translational efficiency of DNA vaccine in mammalian cells: analysis of plasmid DNA encoding a CTL epitope derived from microorganisms. *Biochim Biophys Res Commun* 261:445–451
47. Ferraro B et al (2011) Clinical applications of DNA vaccines: current progress. *Clin Infect Dis* 53:296–302
48. Chang DZ, Lomazow W, Somberg CJ, Stan R, Perales MA (2004) Granulocyte-macrophage colony stimulating factor: an adjuvant for cancer vaccines. *Hematology* 9:207–215
49. Mohan CM, Dey S, Rai A, Kataria JM (2006) Recombinant haemagglutinin neuraminidase antigen-based single serum dilution ELISA for rapid serological profiling of Newcastle disease virus. *J Virol Methods* 138:117–122
50. Dey S et al (2004) Recombinant LipL32 antigen-based single serum dilution ELISA for detection of canine leptospirosis. *Vet Microbiol* 103:99–106
51. Ruiz-Hernandez R et al (2014) An infected chicken kidney cell co-culture ELISpot for enhanced detection of T cell responses to avian influenza and vaccination. *J Immunol Methods* 416:40–48
52. Ariaans MP (2008) ELISPOT and intracellular cytokine staining: novel assays for quantifying T cell responses in the chicken. *Dev Comp Immunol* 32:1398–1404

Part III

Vaccines for Fishes and Shellfish

Selection of Vaccine Candidates for Fish Pasteurellosis Using Reverse Vaccinology and an In Vitro Screening Approach

Francesca Andreoni, Giulia Amagliani, and Mauro Magnani

1 Introduction

Photobacteriosis or fish pasteurellosis is a septicemia caused by the gram-negative, halophilic bacterium *Photobacterium damsela* subsp. *piscicida* (*Pdp*) [1]. It is considered one of the most threatening diseases in world aquaculture due to high mortality, broad host range, and ubiquitous distribution [2]. Research has been focused on the development of effective vaccines to prevent photobacteriosis and limit antibiotic use in fish farming and consequently to reduce economic losses in aquaculture. Conventional *Pdp* vaccines, based on inactivated products containing cellular (heat- or formalin-killed bacteria) and soluble antigens (LPS and ribosomal formulations), appeared to be ineffective in protecting against pasteurellosis and the only commercially available vaccine, an ECP-enriched bacterin preparation, gave unreliable results [1, 3]. Recently, recombinant DNA technology has been applied for the development of bivalent subunit vaccine in cobia [4], and a DNA vaccine encoding codon-optimized 7 kDa lipoprotein has been investigated in Japanese flounder [5].

In our laboratory, a biotechnological approach based on *reverse vaccinology* has been applied to design a vaccine against fish pasteurellosis. Here we describe the selection of antigen vaccine candidates which is accomplished in two steps: (a) *in silico* methods for selecting surface-exposed or secreted proteins; (b) *in vitro* screening of the *in silico* selected vaccine candidates by an adherence inhibition assay.

Genomic sequences of *Pdp* are the starting point for bioinformatic analysis aiming to identify new proteins and predict their localization. Bacterial proteins, when localized on the surface, have the potential to be ideal targets for antibody recognition and

therefore ideal vaccine antigens [6]. The antigens identified by *reverse vaccinology* should possibly be further screened by an in vitro assay. This aims to reduce the number of antigen candidates to be tested in the in vivo experiments which evaluate the survival of fish experimentally immunized with those antigens after challenge.

The attachment of *Pdp* to host epithelial cells is a primary prerequisite for infections and a crucial step in pathogenesis. Adherence is a multifactorial process mediated by a number of surface-exposed organelles and secreted toxins, known as adhesins, that are of considerable interest as potential vaccine targets [7]. For this reason, the inhibition of *Pdp* adherence on fish epithelial cells can be used as a further selection tool to identify proteins with vaccine potential. For the in vitro assays, the selected antigens, produced as recombinant proteins, are used for mice immunization and the immunoglobulins purified from mice immune sera are tested in an adherence inhibition assay with *Pdp* and fish cell lines.

2 Materials

2.1 *In Silico* Analysis

2.1.1 Open Reading Frame Identification and Annotation

1. GLIMMER is a software product used to find genes in microbial DNA, especially the genomes of bacteria and archaea. GLIMMER (Gene Locator and Interpolated Markov ModelER) uses interpolated Markov models to identify coding regions and distinguish them from noncoding DNA [8]. Glimmer v3.02 can be downloaded from the Center for Bioinformatics and Computational Biology (<http://ccb.jhu.edu/software/glimmer/index.shtml>) or is available online at The National Center for Biotechnology Information (NCBI) (http://www.ncbi.nlm.nih.gov/genomes/MICROBES/glimmer_3.cgi).
2. GeneMark is a family of gene finding programs developed at [Georgia Institute of Technology](#) that has been used for prokaryotic genome annotation. Novel genomic sequences can be analyzed either by the self-training program [GeneMarkS](#) (sequences longer than 50 kb) or by [GeneMark.hmm with Heuristic models](#) [9]. For many species, pre-trained model parameters are ready and available through the [GeneMark.hmm](#) page (<http://opal.biology.gatech.edu/GeneMark/gmhmp.cgi>).
3. The Basic Local Alignment Search Tool (BLAST) search against the NCBI nonredundant protein database can be used to find local regions of similarity or global alignment and identify functional relationships between sequences. Additional BLAST programs and databases can be useful in identifying very distantly related proteins or members of gene families

(Position-Specific Iterated (PSI)-BLAST) and conserved protein domains (Reverse Position Specific BLAST (RPS)-BLAST) [10, 11]. <http://blast.ncbi.nlm.nih.gov/Blast.cgi>

4. tRNAscan-SE searches for tRNA genes in genomic sequences. It is routinely used for completed genomes, resulting in the identification of thousands of tRNA genes [12]. The tRNAscan-SE server is accessed via the Lowe Lab Webserver Interface at <http://lowelab.ucsc.edu/tRNAscan-SE/>
5. The RNAmmer 1.2 server predicts 5S/8S, 16S/18S, and 23S/28S ribosomal RNA in full genome sequences [13]. RNAmmer is available at the CBS Prediction Server for RNAmmer: <http://www.cbs.dtu.dk/services/RNAmmer/>

2.1.2 Subcellular Localization Prediction

1. The PSORT family of programs analyzes several features at once, using information obtained from each analysis to generate an overall prediction of localization site. Originally developed for prediction of protein localization in gram-negative bacteria, PSORT was expanded into a suite of programs (PSORT, PSORT II, iPSORT) capable of handling proteins from all classes of organisms [14]. PSORTb v3.0.2 is available at <http://www.psort.org/psortb/index.html>
2. SignalP 4.1 server predicts the presence and location of signal peptide cleavage sites in amino acid sequences from different organisms: gram-positive and gram-negative prokaryotes and eukaryotes. The method incorporates a prediction of cleavage sites and a signal peptide/non-signal peptide prediction based on a combination of several artificial neural networks [15]. <http://www.csb.dtu.dk/services/SignalP/>
3. The TMPred program makes a prediction of membrane-spanning regions and their orientation. The algorithm is based on the statistical analysis of TMbase, a database of naturally occurring transmembrane proteins. The prediction is made using a combination of several weight-matrices for scoring [16]. It is available at http://www.ch.embnnet.org/software/TMPRED_form.html
4. The LipoP 1.0 server produces predictions of lipoproteins and discriminates among lipoprotein signal peptides, other signal peptides, and N-terminal membrane helices in gram-negative bacteria [17]. <http://www.cbs.dtu.dk/services/LipoP/>
5. DOLOP software searches for probable lipoprotein signal sequence using the following criteria: presence of + charged amino acids in the initial residues, presence of at least 7–22 residues between the predicted Lipobox and the charged residue, presence of a Lipobox within the first 40 residues from the N-terminus with the consensus as [LVI][ASTVI][ASG]

[C] [18]. <http://www.mrc-lmb.cam.ac.uk/genomes/dolop/analysis.shtml>

6. BLAST can be used to predict protein function and evolutionary relationships between sequences. <http://blast.ncbi.nlm.nih.gov/Blast.cgi>
7. The ClustalW program (<http://www.ebi.ac.uk/Tools/msa/clustalw2/>) or Pairwise Sequence Alignment (<http://www.ebi.ac.uk/Tools/psa/>) are useful tools for multiple or two sequence alignment, respectively.

2.2 Adherence Inhibition Assay

2.2.1 Cell Culture

1. Chinook salmon embryo cell line CHSE-214 purchased from Istituto Zooprofilattico Sperimentale della Lombardia e dell'Emilia Romagna (IZSLER, Italy).
2. EMEM (Minimum Essential Medium Eagle with Earle's Salts and NaHCO₃) (Sigma-Aldrich Corp. St. Louis, MO USA).
3. Fetal calf serum (FCS) (Mascia Brunelli, Milan, Italy) heat-inactivated for 30 min at 56 °C. Store 10 ml aliquots at -20 °C.
4. L-glutamine solution 200 mM, sterile-filtered (Sigma).
5. MEM nonessential amino acid solution (NEAA) (100×) without L-glutamine, liquid, sterile-filtered (Sigma).
6. Gentamicin solution 50 mg/ml in deionized water, sterile-filtered (Sigma).
7. *N*-2-hydroxyethylpiperazine-*N'*-2-ethanesulfonic acid (HEPES) (F.W.: 238.3 g/mol) (Sigma). Dissolve 1.1915 g in 10 ml ultrapure grade water. Filter-sterilize with membrane 0.2 μm pore size. Store at +4 °C.
8. Trypsin-EDTA Solution 10×: 0.5 % trypsin, 0.2 % EDTA (Sigma).
9. Trypan blue solution 0.4 %, sterile-filtered (Sigma).
10. 1× phosphate buffered saline (PBS Buffer). Dissolve the following in 800 ml distilled H₂O: 8 g of NaCl (137 mM), 0.2 g of KCl (2.7 mM), 1.44 g of Na₂HPO₄ (10 mM), 0.24 g of KH₂PO₄ (2 mM). Adjust pH to 7.4 with HCl. Adjust volume to 1 l with additional distilled H₂O. Sterilize by autoclaving.

2.2.2 Bacterial Culture

1. *Pdp* 249/I99, virulent strain obtained from the Istituto per l'Ambiente Marino Costiero (IAMC) CNR, Messina (Italy).
2. Tryptone Soya Agar (TSA) (Oxoid Ltd, Basingstoke, UK), Marine Broth (Difco, BD, New Jersey, USA). Refer to manufacturers' instruction for culture media preparation.
3. NaCl (Sigma).

2.2.3 Antigens and Immunoglobulins

1. Purified recombinant antigens and anti-recombinant protein immunoglobulins are obtained as reported in Ref. [19].

2.2.4 DNA Extraction and Real-Time PCR

1. Lysis solution: 10 mM Tris–HCl pH 8.0, 1 mM EDTA, 0.5 % Tween 20 in ultrapure grade water. Proteinase K 0.1 mg/ml is added immediately before use. All reagents are from Sigma.
2. RNaseA (Sigma): 20 µg/ml solution in ultrapure grade water, stored at –20 °C.
3. Hot-Rescue Real-Time PCR—SG kit (Diatheva, Fano, Italy).
4. Oligonucleotide primers from Sigma.

2.2.5 Statistical Analysis

1. GraphPad InStat version 3.06 (GraphPad Software), available at <http://www.graphpad.com/scientific-software/instat/>

3 Methods

3.1 *In Silico* Selection of Vaccine Candidates

The primary condition for a bacterial protein to be selected as a vaccine candidate is its cellular localization. In fact, cytosolic proteins are unlikely to be immunological targets, whereas surface-exposed and secreted proteins are more easily accessible to the host immune system [20]. Potential vaccine candidates can be selected by the *reverse vaccinology* approach, using bioinformatic algorithms to identify new proteins localized on the bacterial surface. The first step is the analysis of the genomic sequences of the pathogen obtained from the NCBI database or a sequencing project in order to identify the putative open reading frames and the corresponding protein sequences. The set of putative proteins is then analyzed by specific software to predict their putative cellular localization. Several computer programs are integrated to identify proteins with a subcellular localization spanning from the cytoplasm to the outer membrane in the case of gram-negative bacteria, identifying signal peptides for surface localization or secretion, and/or transmembrane helices.

Furthermore, protein conservation should be evaluated by comparing the sequences of different strains of the same species to determine whether the genes of interest are widely distributed (Fig. 1).

3.1.1 Gene Identification

1. New sequences are analyzed with GLIMMER for gene annotation. Upload the sequence from file or copy and paste the sequence in FASTA format, select the genetic code 11 for bacteria and archaea and the topology of the DNA sequence and run GLIMMER. A list of ORFs is obtained with indication of the start, the end, and the reading frame.
2. ORFs identification can also be achieved with GeneMark. Enter the sequence in FASTA format or upload as file, select the most closely related bacterial species from the list available as model parameters and run GeneMark. The results include

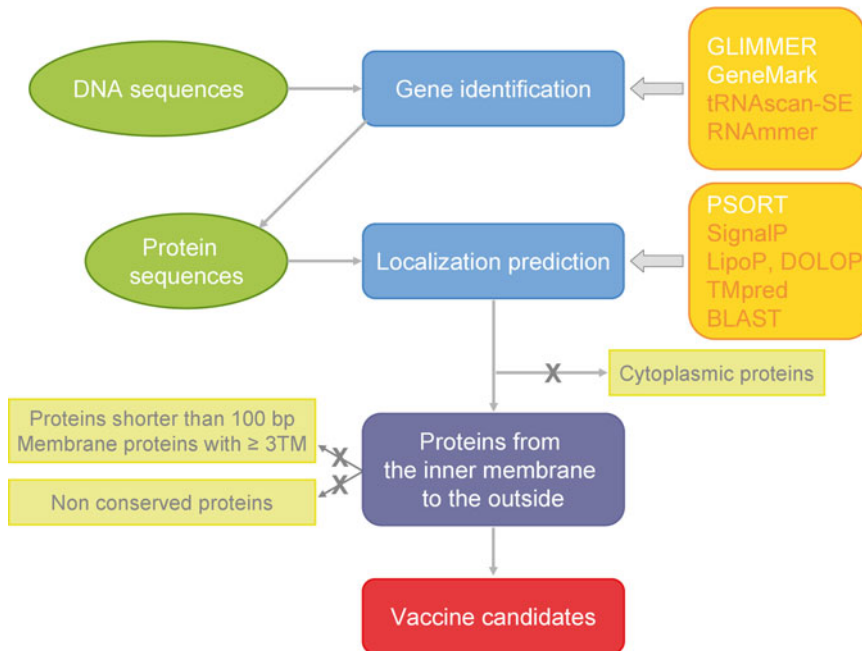

Fig. 1 Schematic representation of the workflow for in silico selection of vaccine candidates. Putative proteins are identified from genomic sequences using GLIMMER and GeneMark and their localization predicted by PSORT and additional computational tools. Cytoplasmic proteins are discarded as well as inner membrane proteins with more than three transmembrane (TM), completely integrated into the membrane or exposed to the cytoplasmic side. Moreover, proteins shorter than 100 amino acids and protein nonconserved among *Pdp* strains are rejected from the list of vaccine candidates. Selected antigens are expressed and purified as recombinant proteins and further investigated by the in vitro assay

the predicted genes with their length, left and right end, and positive/negative strand (*see Note 1*).

3. Search for tRNAs and rRNA genes using tRNAscan-SE and RNAmmer, respectively. Before submission of the input sequence, select the kingdom of your sequence in the case of the RNAmmer server.
4. Combining the results, the complete list of all genes and the corresponding proteins encoded by the genomic sequences will be obtained.

3.1.2 Localization Prediction

Several computational tools are used for the identification of vaccine candidates on the basis of sequence features.

1. The protein subcellular localization is predicted using PSORT. Upload the file including one or more predicted proteins in FASTA format, choose the appropriate Gram-stain (*see Note 2*) and organism domain (Bacteria or Archaea) for your sequences. Running PSORT will result in the putative subcellular localization associated with each protein (*see Note 3*).

2. ORFs coding for proteins with known cytoplasmic function are not further investigated and are discarded.
3. Proteins with unknown localization obtained from PSORT or with a localization spanning from the inner membrane to the outside of the bacterium are further analyzed.
4. The amino acid sequences are analyzed with SignalP to predict the signal peptide sequences. Submit sequences as single amino acid sequence or several sequences in FASTA format and select organism type. Standard output shows one plot with the three different scores for each position in the sequence and one summary per sequence indicating the maximal values of the three scores. In addition, the *D*-score (discrimination score) is reported and this is used to discriminate signal peptides from non-signal peptides. If the signal peptide is detected, the position of the cleavage site is indicated. For non-secretory proteins, all the scores represented in the SignalP output should ideally be very low (close to the negative target value of 0.1) (*see Note 4*).
5. TMpred is used to identify putative hydrophobic membrane regions in the amino acid sequence. The output reports the preferred model with predicted transmembrane helices, their orientation and the orientation of the protein in relation to the membrane.
6. Inner membrane proteins with more than three hydrophobic transmembrane domains are discarded because of their higher rate of expression failure [6]; furthermore, cytoplasmic membrane proteins completely integrated into the membrane or exposed to the cytoplasmic side are excluded from the selection of vaccine candidates.
7. Predicted proteins shorter than 100 amino acids are also discarded.
8. LipoP and DOLOP are useful to predict lipoproteins. LipoP discriminates between lipoprotein signal peptides with cleavage sites for signal peptidase II and other signal peptides for signal peptidase I. The prediction also reports the cleavage site and the amino acid in position +2 after the cleavage site. DOLOP also describes the individual parts in the signal sequence: the positively charged region, the hydrophobic region, and the Lipobox.
9. A localization prediction is assigned to each protein by comparing and complementing the results of the abovementioned programs.
1. The function of each protein and putative domains are predicted through a sequence homology search using BLAST and PSI-BLAST that supply further information for vaccine candidate selection.

2. Proteins with sequence similarity to known virulence factors of other bacteria are selected.
3. Sequence conservation of antigen vaccine candidates among different strains of the bacterium should be evaluated. The comparison of genomic sequences of different strains of the same species assesses whether the genes of interest are widely distributed. When multiple genome sequences are not available from public databases, as in the case of *Pdp*, conservation of the vaccine candidates is determined by PCR amplification of DNA from various strains using the primers designed for cloning the selected sequence into expression vector.
4. Proteins the genes of which were not present in the genome of the analyzed strains are discarded as vaccine candidates.
5. Combining these results, a set of promising vaccine candidates is selected in silico for further in vitro investigation.

3.2 Adherence Inhibition Assay

The aim of the assay is the investigation of the possible effect of immunoglobulins obtained from mice immunization with the purified recombinant vaccine antigens on the adherence and internalization of *Pdp* 249/I99 to epithelial cells CHSE-214.

1. Preparation of CHSE-214 monolayers. Chinook salmon embryo cells CHSE-214 are grown in EMEM supplemented with 20 % FCS, 1 % L-glutamine, 1 % NEAA, 10 µg/ml gentamicin, 5 mM HEPES (complete medium) in 25 ml flasks at 22 °C. To prepare cell monolayers for the experiment, the culture medium is removed and discarded from a flask (*see Note 5*) and cells are washed with 3 ml PBS; then 500 µl Trypsin-EDTA are added (*see Note 6*) and the culture vessel gently swirled until cell detachment from flask. Two milliliters of complete medium is added to the cell suspension, gently pipetting to completely dissociate cell aggregates, then flask content is transferred to a 15-ml tube and centrifuged at 300×*g* for 6 min. After withdrawing the supernatant, cells are resuspended in complete medium. A 20 µl-aliquot is diluted 1:1 with Trypan blue solution and counted in hemocytometer chamber: nonviable cells appear blue, viable cells remain unstained (Trypan blue exclusion test for cell viability).

Semiconfluent cell monolayers of CHSE-214 are obtained by seeding 1×10^5 cells per well in a 24-well plate in 1 ml of complete medium, with incubation at 22 °C for 24 h before infection.

2. Preparation of infection suspension of *Pdp*. The virulent strain of *Pdp* 249/I99 is culture plated on Tryptone Soya Agar (TSA)+1.5 % NaCl, with incubation at 25 °C for 48 h. A bacterial colony is then resuspended in Marine Broth and grown

overnight at 25 °C with shaking. The bacteria suspension is adjusted to an OD₆₀₀ of 0.2, corresponding to approximately a concentration of 1×10^8 CFU (colony forming units)/ml (*see Note 7*). The actual bacterial titre is verified by plating decimal dilutions of the suspension on TSA+1.5 % NaCl and colony counting after incubation at 25 °C for 24–48 h.

3. Bacteria incubation with immunoglobulins. Bacterial suspension is harvested by centrifugation at $6000 \times g$ for 15 min and resuspended in saline solution with or without anti-recombinant protein immunoglobulins in a ratio of 10^7 bacteria: 100 µg immunoglobulins. After incubation for 1 h at room temperature with rotation, bacteria are centrifuged as above and resuspended in infection medium (that is complete medium without gentamicin and a FCS content reduced to 2 %).
4. Cell infection. Cell monolayers are washed, replacing the culture medium with fresh complete medium without antibiotic, and infected with *Pdp* prepared as described, with a multiplicity of infection (m.o.i.) of 1:100 (10^5 cells to 10^7 bacteria). Cell monolayers infected with *Pdp* but not treated with immunoglobulins or with unrelated immunoglobulins (from non-immunized mice) may also be included as controls. Infected monolayers are incubated overnight (approximately 15 h) at 22 °C to allow bacterial adhesion and/or internalization (Fig. 2).
5. DNA extraction. After infection, cell monolayers are washed three times with EMEM (1 ml per well) to remove non-adherent and non-internalized bacteria. Cells are detached with 600 µl of lysis solution for 10 min, transferred to 1.5 ml microcentrifuge tubes, incubated 1 h at 60 °C, then 15 min at 95 °C. Lysates are centrifuged for 10 min at $13,000 \times g$ and treated with 20 µg/ml RNase A for 30 min at 37 °C.
6. Real-time PCR. The inhibition of adherence is evaluated in real-time PCR after lysis of infected cell monolayers. For the amplification of *Pdp* and CHSE-214 DNA, two pairs of primers are used, targeting *PDP_0080* gene (GenBank ID: HQ599846) and *PRLII* gene (prolactin II gene, GenBank ID: S66606) of Chinook salmon (*Oncorhynchus tshawytscha*), respectively. Five microliters of each extracted sample is amplified in triplicate with 1 U DNA polymerase and 0.3 µM of either *PDP_0080*-specific primers (*PDP80_1F*, 5'-TGCTGATACACGTTTGGAGAGA-3'; *PDP80_1R*, 5'-CGTCTGCCGTTAAAATACGAGA-3'; PCR product length 146 bp) or *PRLII*-specific primers (*PRL3*, 5'-TCCCACCTTGTAGGACGAATAA-3'; *PRL4*, 5'-GGTGGACAAAAGCTGTTGGA-3'; PCR product length 116 bp). The amplification is carried out in a real-time PCR instrument with the following thermal protocol: denaturation at 95 °C for 10 min; 35 cycles

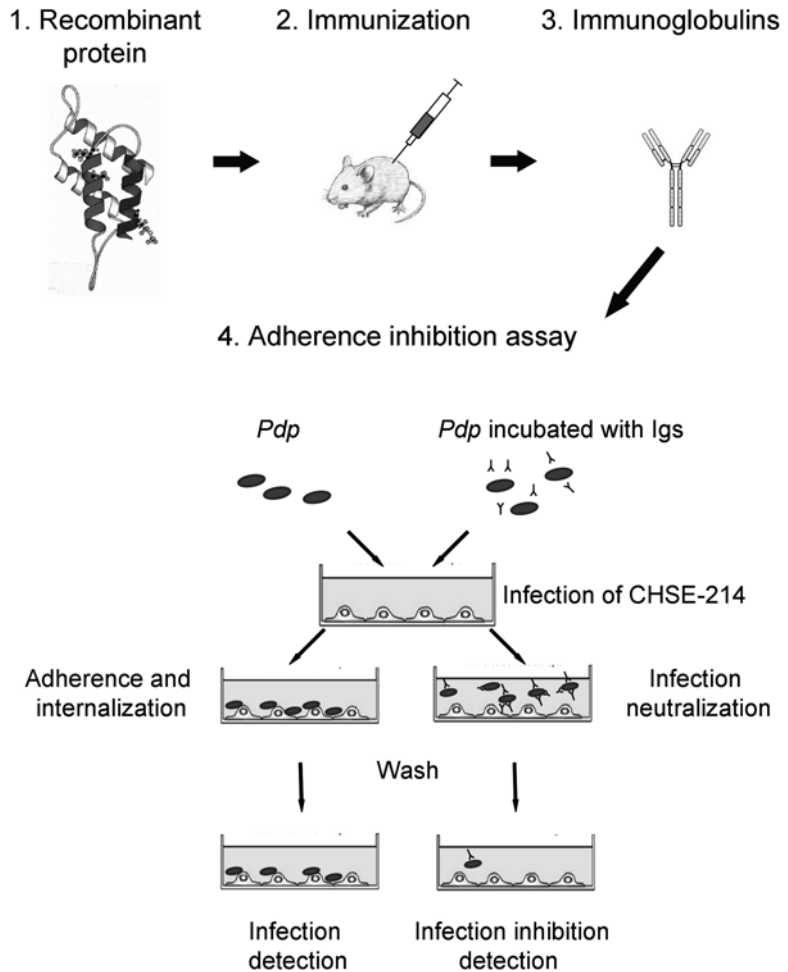

Fig. 2 A schematic representation of the in vitro screening tests. After mice immunization with recombinant proteins, immunoglobulins are purified from mice immune sera and used for the subsequent adherence inhibition assay. CHSE-214 cells are inoculated with *Pdp* pre-incubated or not with mice anti-recombinant protein immunoglobulins. The inhibition of bacteria adherence and/or internalization into cell monolayers is assessed by quantitative real-time PCR

at 95 °C for 15 s and 60 °C for 1 min; melt analysis at 72–95 °C (see **Note 8**).

7. Analysis of results. The inhibitory effect of immunoglobulins is estimated by relative quantization in real-time PCR ($2^{-\Delta\Delta C_T}$ method) (see **Note 9**), in which the amplified sequences of *PDP_0080* and *PRLII* are selected as “target” and as “normaliser”, respectively. The number of adherent/internalized bacteria should be calculated as percentage of the initial inoculum, and values expressed as fold difference as compared to the control.

8. Statistical analysis. Results should be calculated as the mean of two/three independent experiments with three replicates each. Result significance is estimated by one-way ANOVA with Dunnett's post test, which can be performed using GraphPad InStat version 3.06 (GraphPad Software).

4 Notes

1. Results of GLIMMER and GeneMark software are compared and when not in agreement the predicted proteins are searched against the NCBI non redundant protein database using the Blast program and analyzed against the NCBI CDD database for prediction of protein domain. Frameshifts and point mutations are detected and corrected where appropriate. Remaining frameshifts and point mutations are considered to be authentic and are annotated as pseudogenes, as are coding regions interrupted by repeated insertion elements.
2. Select "Advanced" in the Gram stain option if you analyze sequences from gram-positive organisms with an outer membrane or gram-negative organisms without an outer membrane.
3. The normal output option displays the results of each of PSORTb's analytical modules (or "Unknown" if the module does not generate a prediction), the localization scores for each of the five sites, as well as a final prediction and associated score (if one site scores above the 7.5 cutoff). If two sites have high scores, "Unknown" appears and a flag stating "This protein may have multiple localization sites" is also returned in the Final Prediction field.
4. Amino acid sequences that give dubious results with SignalP are further investigated to search for non classical leader peptides, e.g., SecretomeP and TatP.
5. Removing all traces of serum is recommended, as serum contains trypsin inhibitors.
6. Pre-warming of Trypsin-EDTA at 37 °C may facilitate cell detachment.
7. The correspondence between optical density (OD_{600}) and bacterial titre of the *Pdp* suspension should be preliminary assessed, since slight variations can be observed with different spectrophotometers.
8. Common precautions should be applied to avoid cross contaminations in all steps of sample preparation and amplification. All phases of molecular analysis should occur in separate areas and with equipment dedicated to that purpose.

9. The amount of target, normalized to a reference and relative to a calibrator, is given by: amount of target = $2^{-\Delta\Delta C_T}$

For the $\Delta\Delta C_T$ calculation to be valid, the amplification efficiencies of the target and the normalizer must be approximately equal. This comparison must be carried out as preliminary validation according to the method described by Livak and Schmittgen [21].

Acknowledgement

This work was supported by Fanoateneo.

References

- Romalde JL (2002) *Photobacterium damsela* subsp. *piscicida*: an integrated view of a bacterial fish pathogen. *Int Microbiol* 5:3–9
- Barnes AC, dos Santos NM, Ellis AE (2005) Update on bacterial vaccines: *Photobacterium damsela* subsp. *piscicida*. *Dev Biol (Basel)* 121:75–84
- Andreoni F, Magnani M (2014) Photobacteriosis: prevention and diagnosis. *J Immunol Res* 2014:793817
- Ho LP, Chang CJ, Liu HC et al (2014) Evaluating the protective efficacy of antigen combinations against *Photobacterium damsela* ssp. *piscicida* infections in cobia, *Rachycentron canadum* L. *J Fish Dis* 37:51–62
- Kato G, Yamashita K, Kondo H, Hirono I (2015) Protective efficacy and immune responses induced by a DNA vaccine encoding codon-optimized PPA1 against *Photobacterium damsela* subsp. *piscicida* in Japanese flounder. *Vaccine* 33:1040–1045
- Pizza M, Scarlato V, Masignani V et al (2000) Identification of vaccine candidates against serogroup B meningococcus by whole-genome sequencing. *Science* 287:1816–1820
- Wizemann TM, Adamou JE, Langermann S (1999) Adhesins as targets for vaccine development. *Emerg Infect Dis* 5:395–403
- Delcher AL, Bratke KA, Powers EC, Salzberg SL (2007) Identifying bacterial genes and endosymbiont DNA with Glimmer. *Bioinformatics* 23:673–679
- Besemer J, Lomsadze A, Borodovsky M (2001) GeneMarkS: a self-training method for prediction of gene starts in microbial genomes. Implications for finding sequence motifs in regulatory regions. *Nucleic Acids Res* 29:2607–2618
- Schaffer AA, Aravind L, Madden TL et al (2001) Improving the accuracy of PSI-BLAST protein database searches with composition-based statistics and other refinements. *Nucleic Acids Res* 29:2994–3005
- Marchler-Bauer A, Lu S, Anderson JB et al (2011) CDD: a Conserved Domain Database for the functional annotation of proteins. *Nucleic Acids Res* 39:D225–D229
- Schattner P, Brooks AN, Lowe TM (2005) The tRNAscan-SE, snoscan and snoGPS web servers for the detection of tRNAs and snoRNAs. *Nucleic Acids Res* 33:W686–W689
- Lagesen K, Hallin P, Rodland EA et al (2007) RNAmmer: consistent and rapid annotation of ribosomal RNA genes. *Nucleic Acids Res* 35:3100–3108
- Yu NY, Wagner JR, Laird MR et al (2010) PSORTb 3.0: improved protein subcellular localization prediction with refined localization subcategories and predictive capabilities for all prokaryotes. *Bioinformatics* 26:1608–1615
- Petersen TN, Brunak S, von Heijne G, Nielsen H (2011) SignalP 4.0: discriminating signal peptides from transmembrane regions. *Nat Methods* 8:785–786
- Hofmann K, Stoffel W (1993) TMbase—a database of membrane spanning proteins segments. *Biol Chem Hoppe-Seyler* 374:166
- Juncker AS, Willenbrock H, Von Heijne G et al (2003) Prediction of lipoprotein signal peptides in Gram-negative bacteria. *Protein Sci* 12:1652–1662
- Madan Badu M, Sankaran K (2002) DOLOP—database of bacterial lipoproteins. *Bioinformatics* 18:641–643
- Andreoni F, Boiani R, Serafini G et al (2013) Isolation of a novel gene from *Photobacterium damsela* subsp. *piscicida* and analysis of the recombinant antigen as promising vaccine candidate. *Vaccine* 31:820–826
- Scarselli M, Giuliani MM, du-Bobie J et al (2005) The impact of genomics on vaccine design. *Trends Biotechnol* 23:84–91
- Livak KJ, Schmittgen TD (2001) Analysis of relative gene expression data using real-time quantitative PCR and the 2(-Delta Delta C(T)) Method. *Methods* 25:402–408

Development of Vaccines Against Nocardiosis in Fishes

Sukanta K. Nayak and Teruyuki Nakanishi

1 Introduction

Nocardiosis is one of the most systemic and devastating disease which is currently affecting a wide range of fish species. It is caused by a Gram-positive, acid-fast bacterium, *Nocardia seriolae*, which is thought to progressively invade and multiply inside various types of fish host cells. Fish species such as Japanese flounder, sea bass, striped mullet, yellowtail, tiger fish, large yellow croaker, and snakehead are frequently affected by this pathogen in many Asian countries including Japan, Malaysia, Taiwan, Indonesia, and China [1–5]. Although *N. seriolae* infection often causes considerable economic loss for fish farms, there are no suitable prophylactic measures against this pathogen [6]. While routine and abundant use of antibiotics lead to increase in antibiotic resistance among the *N. seriolae* isolates and/or ineffective in controlling the nocardiosis [5, 7], the development of a successful vaccine would be greatly welcomed.

Immunization/vaccination is an important disease management strategy and is used to protect human and animal worldwide and fish is no exception and its success depends upon the ability of antigen to ensure significant immune response that could best protect the host against that particular pathogen or disease. As *N. seriolae* infection causes substantial mortality and morbidity in fishes, an effective vaccine against this pathogen is necessary to control the disease. An understanding of the immune mechanisms in fishes would facilitate protective immunity. Though several attempts have been made to develop live attenuated and inactivated vaccine against *Nocardia*, most attempts either failed or marginally succeeded [8–12]. Detailed understanding of immune response triggered by the pathogen and/or its inactive form is therefore extremely important to adopt appropriate measures to protect the animals from nocardiosis.

Recently, we have analyzed both cellular and humoral immune responses to study the nature of immunity which is crucial against nocardiosis. Itano et al. [12] suggest the use of a low virulence *N. seriolae* isolate as a potential vaccine (strain) and demonstrated protection following virulent challenge. Modified live vaccines often stimulate long lasting humoral and cellular immune responses [13]. Nayak et al. [14] demonstrated that various immune parameters in the live sublethal immunized, though not at significant level were higher as compared with inactivated form of *N. seriolae*. They have also observed detectable antibodies after 15 days post immunization but the level decreased with subsequent sampling which is contrary to the findings of Shimahara et al. [6] who had recorded significantly high antibody which persisted throughout the experiment in largemouth bass following primary immunization. Moreover, earlier studies also indicate that the formalin-killed *N. seriolae* cells and Freund's incomplete adjuvant (FIA) emulsified formalin-killed *N. seriolae* cells to induce humoral immune responses [6, 8–10]. The role of humoral immunity in protection against diseases is somehow contradictory in the case of *N. seriolae*. While Kusuda and Nakagawa [8] reported elevated antibody levels and protective effects after immunization with formalin-killed cells and those emulsified with FIA. Conversely, Shimahara et al. [10] reported that no protective effects resulted from immunization with formalin-killed cells or those with FIA and furthermore, Shimahara et al. [10] failed to reduce mortality even with multiple injections of four different *N. seriolae* strains irrespective of the bacterium and antibody level in largemouth bass.

Several recent studies in fish have found both live as well as inactivated antigenic form of a particular pathogen to be effective against various infectious organisms. We have evaluated the efficiency of both live and inactivated antigenic forms of the *N. seriolae* on various immune parameters using ginbuna crucian carp, *Carassius auratus langsdorfi* as a fish model in order to obtain adequate desired but essential knowledge for vaccine development against nocardiosis in fish. Our study indicates that both forms of *N. seriolae* are capable of eliciting effective immune response with significant elevation of CD8 α^+ T cells and surface IgM positive cells (sIgM $^+$ cells) which in turn played crucial role in protecting ginbuna upon challenge with virulent strain of *N. seriolae*.

2 Materials

- 2.1 Candidate Strain** Pathogenic strain of *Nocardia seriolae*.
- 2.2 Fish** Ginbuna crucian carp (*Carassius auratus langsdorfi*) (15–20 g size).

- 2.3 Bacteriological Media** Brain heart infusion (BHI)/Lowenstein-Jensen (L-J) media.
- 2.4 Cell Culture Media and Serum** Minimum essential medium (Opti-MEM), Hank's balanced salt solution (HBSS), fetal bovine serum (FBS).
- 2.5 Aquaria** Aquaria with thermostat, running water, and proper aeration facility.
- 2.6 Antigen** 1 % formalin killed *N. seriolae* antigen ($\sim 10^8$ CFU/mL).
- 2.7 Monoclonal Antibodies** Monoclonal antibodies (MAbs) against ginbuna CD8 α , CD4 and surface IgM.
- 2.8 Buffers and Reagents** 1.08 g Percoll per 1 mL HBSS and prepare the gradient as per requirement.
- 2.8.1 Percoll Gradient**
- 2.8.2 FACS Buffer** Add 0.9 g of Hank's balanced salt with 0.1 g of bovine serum albumin (BSA), 1.0 mL of 10 % NaN₃ and 0.2 mL of FBS and 33 mg of sodium bicarbonate in 100 mL of distilled water (DW). The pH of the buffer should be 7.2–7.4.
- 2.8.3 MACS Buffer** The composition of the Magnetic activated cell sorting (MACS) buffer is same as that of FACS. Prepare the buffer in the laboratory and then degas the buffer completely under vacuum condition.
- 2.8.4 ELISA Buffer**
- Coating buffer** {Carbonate-Bicarbonate buffer (0.05 M, pH 9.5)}: Dissolve sodium carbonate (1.59 g) and sodium bicarbonate (2.92 g) in 1 L DW. Add 0.2 g of sodium azide and store at 4 °C till further use.
 - Washing buffer** (PBS-Tween, pH 7.2): Dissolve sodium chloride (8 g), potassium chloride (0.2 g), potassium dihydrogen phosphate (0.2 g), disodium hydrogen phosphate (1.15 g) in 1 l DW and then add 0.5 mL of Tween 20.
 - Blocking solution**: Prepare 5 % skimmed milk powder in washing buffer.
 - Substrate solution**
Prepare the substrate solution by mixing 5 mg of *O*-phenylenediamine dihydrochloride, 10 μ L of H₂O₂ (38 % v/v) in 5 mL of acetate buffer [(0.2 M, pH 5.0) Add 14.8 mL of acetic acid solution (acetic acid 120 mL in 1 l DW) with 35.2 mL of sodium acetate solution (14.4 g of sodium acetate in 1 l DW)]. Protect the prepared substrate solution from light and use immediately.
 - Stopping solution**: Prepare 3 N H₂SO₄ solution.

3 Methods

3.1 Monoclonal Antibodies

1. Produce the monoclonal antibodies (MAbs) against ginbuna CD8 α and CD4 as per the method reported by Toda et al. [15].
2. Express the ginbuna CD8 α or CD4 in normal rat kidney fibroblast (NRK) cells using a retrovirus-mediated gene transfer system.
3. Inject CD8 α^+ or CD4 $^+$ expressing NRK cells into the footpad of the syngeneic Wistar rat.
4. Three days after the final immunization, sacrifice the rats and collect lymph node cells and fuse with mouse myeloma cells (P3 \times 63-AG8.653).
5. The MAbs 6D1 (anti-ginbuna CD4 rat IgG2a) or 6C10 (anti-ginbuna CD8 α -rat IgG1) positive cells are subpopulations of IgM-negative lymphocytes. Check for the cross-reactivity among the two MAbs.
6. Likewise, produce the monoclonal antibodies (MAbs) against ginbuna IgM as reported by Somamoto et al. [16] and Takizawa et al. [17].

3.2 Pathogenicity Study

1. If nocardiosis is not common in fish and/or the source of candidate vaccine strain is from different fish, establish pathogenicity of the candidate *N. seriolae* strain by intraperitoneally injecting the fish (10 per concentration) with 100 μ l of *N. seriolae* cell suspension at varying concentration ranging from 10⁶ to 10¹⁰ CFU/mL.
2. Observe the mortality in each challenged dose along with clinical sign and symptoms of nocardiosis up to 45 days (*see Note 1*).
3. Perform autopsy of all the moribund and freshly dead fish. Collect samples from kidney, spleen, hepatopancreas and blood of moribund fish for detecting the *N. seriolae* by inoculating the samples onto BHI and/or LJ agar plates and also through 16S rRNA gene sequencing by using 27F (5'-AGA GTT TGA TCC TGG CTC AG-3'; positions 8–27) and 1492R (5'-TAC GGC TAC CTTGTT ACG ACT T-3'; positions 1513–1492) primers.

3.3 Determination of Sublethal Dose of *N. seriolae*

1. Based on the findings of the pathogenicity study, inject the ginbuna with the lowest dose of *N. seriolae* which causes no mortality to find out the persistence of the pathogen before selecting it as a sublethal dose (*see Note 1*).
2. Critically observe the injected fish for clinical symptoms of disease and mortality, (if any). Confirm the persistence of *N. seriolae* in different tissues like kidney, hepatopancreas of injected ginbuna up to 45 days (*see Note 2*).
3. Sacrifice a minimum of three injected fish (per sampling) as per standard ethical procedures at various sampling time points

and aseptically collect kidney and hepatopancreas in order to determine the presence/total load of *N. seriolae* in the injected ginbuna.

4. Perform bacteriological and molecular assays to confirm the presence of *N. seriolae* in a similar manner as done in the pathogenicity study. Further if possible, determine the total viable count (CFU assay) bacterial load by standard microbiological total plate count method.

3.4 Vaccinations of Ginbuna with Live (Sublethal)/Antigenic *N. seriolae*

1. Immunize ginbuna with intraperitoneal injection of 100 μ L of live sublethal (in our case 10^6 CFU/mL) and inactivated *N. seriolae* (10^8 CFU/mL) (*see Note 2*).
2. Evaluate both cellular and humoral immune responses of ginbuna immunized with live (sublethal)/inactivated antigen at various sampling period up to 30 days post vaccination (*see Note 3*).

3.5 Evaluation of Immune Responses

1. For cellular immune parameters (T cells and B cells population in blood/various tissues) study, collect the blood samples through caudal puncture from immunized fish by using heparinized syringe. Sacrifice the fish as per standard ethical procedures and aseptically collect tissues like head kidney, trunk kidney and spleen (*see Note 4*).
2. For humoral immune response, collect serum from blood samples of immunized ginbuna to determine the antibody level.

3.6 Assessment of Cellular Parameters

3.6.1 Preparation of Lymphocyte Rich Fraction

1. Immediately, after collection of the blood and tissue samples for the determination of cellular immune parameters, process the samples for isolation of CD8 α^+ , CD4 $^+$ and sIgM $^+$ cells.
2. Prepare leucocyte suspension from the spleen, head kidney and trunk kidney of immunized ginbuna by aseptically disaggregating these tissues with help of sterilized 150-gauge mesh stainless steel sieve in minimum essential medium (Opti-MEM) supplemented with 0.5 % heat-inactivated FBS.
3. Likewise prepare the leucocyte suspensions from peripheral blood by disrupting/lysing the RBCs by gentle mixing with equal amount of sterile distilled water. Then immediately add slowly equal volume of 2 \times Opti-MEM containing 0.5 % heat-inactivated FBS. Collect/suspend the leucocytes in Opti-MEM containing 0.5 % heat-inactivated FBS after three times washing in the same media by centrifuging the sample at 4 $^{\circ}$ C at $400 \times g$.
4. Separate the lymphocyte rich fractions by layering the leucocyte suspension over the Percoll density gradient (1.08 g/mL) at equal proportion followed by centrifugation at $450 \times g$ for 30 min at 4 $^{\circ}$ C. After centrifugation collect the lymphocyte rich fraction from the interface of cell suspension and Percoll.

3.6.2 Separation of Different T Cells/B Cells by Magnetic Activated Cell Sorting (MACS)

1. Separate different T/B cell fractions ($CD8\alpha^+/CD4^+/sIgM^+$ cells) from the lymphocytes rich fraction by using specific mAb rose against respective type of cells followed by magnetic activated cell sorting (MACS).
2. Add the lymphocyte rich fractions at 1×10^7 cells/mL with diluted rat anti-ginbuna $CD8\alpha$ MAb at 1:10⁴ ratio for 45 min on ice. After incubation, wash the cells three times with the medium and adjust the cells to 1×10^8 cells/mL with 1 mL of a 1:5 dilution of magnetic bead-conjugated goat anti-rat Ig antibody for 15 min at 4 °C. After incubation wash the cells for three times.
3. Separate $CD8\alpha$ positive and negative cells with MACS by applying the cell suspension to a plastic column equipped with an external magnet. The $CD8\alpha^+$ cells will be retained in the column, while the $CD8\alpha^-$ cells will pass through the column.
4. $CD8\alpha^-$ fraction are then separated into $CD4$ positive and negative fractions using rat anti-ginbuna $CD4$ MAb in a similar manner as described above.
5. Finally, separate $sIgM$ positive and negative fractions from $CD8\alpha$ and $CD4$ double negative cells by using mouse anti-ginbuna IgM MAb.

3.6.3 FACS Analysis of Cell Fractions

1. Check the viability of individual cell fractions by trypan blue dye exclusion and determine the percentage of each type of MACS separated cell fraction by FACS as per standard procedure. For this, incubate a portion of $CD8\alpha^+$ and/or $CD4^+$ cell fraction with FITC conjugated goat anti-rat IgG+M+A antibody with anti-ginbuna $CD8\alpha$ and/or $CD4$ monoclonal antibodies.
2. Similarly, incubate a portion of $sIgM^+$ cells with FITC conjugated goat anti-mouse Ig G+M antibody (KPL) with an anti-ginbuna IgM monoclonal antibody.
3. Finally, determine the percentage of each cell type in FACS through PI staining.

3.7 Assessment of Humoral Responses

Determine the antibody level as a measure of humoral immune response in both the immunized groups by indirect ELISA.

3.7.1 Enzyme Linked Immunosorbent Assay (ELISA)

1. Determine the antibody titer of the immunized ginbuna serum samples by indirect enzyme linked immunosorbent assay (ELISA) in 96-well microtiter polystyrene plates.
2. Coat the required number of wells in the microtiter plates with 50 μ L (2–4 μ g/well) of whole cell lysate [14] of *N. seriola* diluted in PBS (pH 7.2) for overnight at 4 °C.
3. After overnight incubation, block the wells of the plates with 100 μ L of 3 % skimmed milk powder diluted in washing buffer (PBS–T).

4. Then, add 50 μL of immunized as well as unimmunized control ginbuna sera serially by two fold dilution to each well and then incubate the plates at 37 °C for 1 h.
5. After incubation, wash the wells of microtiter plates thrice with PBS-T and then add 50 μL of mouse anti-ginbuna Ig M mAb (1:50 dilution, *see Note 5*) to each coated well at 37 °C for 1 h.
6. After incubation, wash the plates in PBS-T for three times followed by addition of 50 μL of anti-mouse IgG-HRP-conjugate (at a dilution of 1:1000, *see Note 5*) to each well in the plates.
7. After 45 min incubation at 37 °C, wash the plates in PBS-T and add 50 μL of substrate solution. Incubate the plates in a dark chamber at 37 °C for 5 min.
8. After color development, stop the reaction in the plates by adding stopping solution.
9. Record the optical density (OD) at 450/655 nm in a microplate reader and analyze the absorbency data by subtracting the average OD value obtained with healthy ginbuna sera.

3.8 Challenge Study

1. Evaluate the protective immunity of the developed vaccine after 30 days post immunization by intraperitoneally challenging 20 immunized ginbuna with 100 μL of live virulent *N. seriolae* with a challenging dose of 1.2×10^8 CFU/mL (*see Note 6*).
2. Similarly, challenge another 20 unimmunized ginbuna with live virulent *N. seriolae* as done above.
3. Monitor the mortality in all groups up to 30 days post challenge and finally determine the relative percent survival (*see Note 7*).

3.8.1 Calculation of Relative Percent Survival (RPS)

$$\text{RPS} = [1 - \{\text{Mortality (\%)} \text{ in immunized group} / \text{Mortality (\%)} \text{ in control group}\}] \times 100.$$

4 Notes

1. The ability of candidate *N. seriolae* strains to establish lethal infection in specific fish species needs to be established. This is important for developing live vaccine if the source of the candidate strain is from another source.
2. The persistence or the time course for the elimination of the candidate strain should be carefully evaluated with respect to individual fish species. Herein, we have evaluated the persistence of the bacterium after 1st, 3rd, 7th, 15th, 30th, and 45th day of post injection.

3. The duration of post immunity assessment and sampling period for assessment of immune parameters of fish should be thoroughly standardized. Herein, we have evaluated various immune parameters at 1st, 3rd, 7th, 10th, 15th, 21st, 30th, and 45th day of post immunization. We have demonstrated that the percentage of CD8 α^+ T cells in spleen and head kidney was significantly higher after 3 days post injection. A similar type of trend was also recorded for surface IgM $^+$ cells.
4. While availability of clonal fish and monoclonal antibodies against T cell subsets in assessing cellular parameters and/or cytotoxicity assay for most of the aquacultured fish is a major problem, determination of cytotoxic effector molecules especially granzyme activities could be a better option due to well conserved catalytic triad residues and substrate binding sites in granzyme B throughout vertebrates [15].
5. The appropriate dilution of anti-mouse IgG-HRP-conjugate; mouse anti-ginbuna IgM mAb for ELISA use should be determined through checkerboard titration method prior to conduct of the experiment.
6. The efficiency of live (sublethal) and/or inactivated antigen should be thoroughly evaluated in specific fish species by cross-protection studies. We have used both live and inactivated antigenic forms of *N. seriolae* and found 62.5 % and 75.0 % survivability in live and inactivated *N. seriolae* immunized group, respectively. However, the findings are needed to be reconfirmed with larger sample size.
7. Finally, a detailed, thorough kinetics on cell-mediated immune response as well as duration of protective immunity should be determined. Herein, we have specified a challenge study after 30 days post immunization based on our previous study [14]. This may change with regard to candidate strain for vaccination, host fish species, and other parameters.

Acknowledgement

This work was supported in part by a postdoctoral fellowship for Dr. Sukanta Kumar Nayak (ID No.: P 09118) from the Japan Society for the Promotion of Science (JSPS) Japan.

References

1. Kudo T, Hatai K, Seino A (1988) *Nocardia seriolae* sp. nov. causing nocardiosis of cultured fish. Int J Syst Bacteriol 38:173–217
2. Chen SC et al (2000) Nocardiosis in sea bass, *Lateolabrax japonicus*, in Taiwan. J Fish Dis 23:299–307
3. Wang GL, Yuan SP, Jin S (2005) Nocardiosis in large yellow croaker, *Larimichthys crocea* (Richardson). J Fish Dis 28:339–345
4. Wang GL, Xu YJ, Jin S, Zhu JL, Yuan SP (2007) Nocardiosis in snakehead, *Ophiocephalus argus* Cantor. Aquaculture 271:54–60

5. Labrie L et al (2008) Nocardial infections in fish: an emerging problem in both freshwater and marine aquaculture systems in Asia. Diseases in Asian aquaculture VI. Fish Health Section, Asian Fisheries Society, Manila, pp 297–312
6. Shimahara Y, Huang YF, Tsai MA, Wang PC, Chen SC (2010) Immune response of largemouth bass, *Micropterus salmoides*, to whole cells of different *Nocardia seriolae* strains. Fish Sci 76:489–494
7. Itano T, Kawakami H (2002) Drug susceptibility of recent isolates of *Nocardia seriolae* from cultured fish. Fish Pathol 37:152–153
8. Kusuda R, Nakagawa A (1978) Nocardia infection of cultured yellowtail. Fish Pathol 13:25–31 (in Japanese)
9. Kusuda R, Kimura K, Hamaguchi M (1989) Changes in peripheral and peritoneal leucocytes in yellowtail *Seriola quinqueradiata* immunized with *Nocardia kampachi*. Nippon Suisan Gakkaishi 55:1183–1188 (in Japanese)
10. Shimahara Y, Yasuda H, Nakamura A, Itami T, Yoshida T (2005) Detection of antibody response against *Nocardia seriolae* by enzyme-linked immunosorbent assay (ELISA) and a preliminary vaccine trial in yellowtail *Seriola quinqueradiata*. Bull Eur Ass Fish Pathol 25:270–275
11. Itano T, Kawakami H, Kono T, Sakai M (2006) Detection of fish nocardiosis by loop-mediated isothermal amplification. J Appl Microbiol 100:1381–1387
12. Itano T, Kawakami H, Kono T, Sakai M (2006) Live vaccine trials against nocardiosis in yellowtail *Seriola quinqueradiata*. Aquaculture 261:1175–1180
13. Shoemaker CA, Klesius PH, Evans JJ, Arias CR (2009) Use of modified live vaccines in aquaculture. J World Aquacul Soc 40:573–584
14. Nayak SK, Shibasaki Y, Nakanishi T (2014) Immune responses to live and inactivated *Nocardia seriolae* and protective effect of recombinant interferon gamma (rIFN γ) against nocardiosis in ginbuna crucian carp, *Carassius auratus langsdorffi*. Fish Shellfish Immunol 39:354–364
15. Toda H, Yabu T, Shiba H, Moritomo T, Nakanishi T (2011) Evaluating antigen-specific cytotoxicity of CD8⁺T cells in fish by granzyme B-like activity. Vet Immunol Immunopathol 141:168–172
16. Somamoto T et al (2006) Expression profiles of TCR β and CD8 α mRNA correlate with virus-specific cell-mediated cytotoxic activity in ginbuna crucian carp. Virology 248:370–377
17. Takizawa F et al (2008) Molecular cloning and expression analysis of T-bet in ginbuna crucian carp (*Carassius auratus langsdorffi*). Mol Immunol 45:127–136

Chapter 14

Design of an Immersion Vaccine Against Aeromonad Septicemia in Perch (*Perca fluviatilis* L.)

Joachim Frey, Sarah E. Burr, and Thomas Wahli

1 Introduction

In contrast to many other intensive livestock production methods, it is very difficult to prevent fish from coming into contact with pathogens, either environmental or harbored by wild fish, as they are most often kept in the pens such as sea cages, ponds, or raceways that are supplied with environmental water. Under such conditions, direct or indirect contact of farmed fish with wild fish is difficult and sometimes impossible to avoid.

A suitable method to protect fish from bacterial infections is vaccination, which currently, plays an important role in large-scale commercial fish farming. It has been a key reason for the success of salmon cultivation and has vastly reduced the usage of prophylactic antibiotics in aquaculture. For example, in Norway, vaccination has led to a 98 % decline in the annual usage of antimicrobial agents in farmed fish since 1987 while, at the same time, production has risen approximately 20 times [1]. Currently, commercial vaccines are available not only for salmon and trout but also for channel catfish (*Ictalurus punctatus*), European seabass (*Dicentrarchus labrax*) and seabream (*Acanthopagrus* sp.), Japanese amberjack or yellowtail (*Seriola quinqueradiata*), tilapia (*Tilapia* sp.), and Atlantic cod (*Gadus morhua*) [2, 3]. Many empirically developed vaccines, based on inactivated bacterial pathogens, have proven to be very efficacious in fish. Large fish such as salmon are currently vaccinated individually by injection of inactivated bacteria or viruses generally with an oily adjuvant [4]. However, this is not a suitable method for the vaccination of smaller fish [4]. In this case, immersion vaccination of fry before transferring them to open fattening units is an efficient and economic practice.

Aeromonas species are gram-negative, water-borne bacteria that cause a variety of diseases in different fish species. In farmed fish, they cause significant morbidity and mortality, leading to substantial economic losses. In salmonid fish, non-motile *Aeromonas salmonicida* subsp. *salmonicida* is recognized as a major pathogen of farmed Atlantic salmon (*Salmo salar* L.), rainbow trout (*Oncorhynchus mykiss* Walbaum) and brown trout (*Salmo trutta fario* L.) [5]. In contrast, various motile *Aeromonas* species are often involved in disease of pond fish where they cause infectious aeromonad septicemia, also known as bacterial hemorrhagic septicemia or red spot disease [6]. Among the motile aeromonads, *Aeromonas hydrophila*, *Aeromonas sobria*, and *Aeromonas caviae* are most commonly associated with diseased fish [7]. As the variety of species, subspecies and subtypes of these pathogens is large [8], farm-specific vaccines are often required and have been shown to give a good protection.

High mortality rates of perch (*Perca fluviatilis* L), raised on an open pilot perch farm situated on a Swiss lake, were a significant obstacle for successful production. Mortality peaked during the low water temperatures of wintertime. The most evident macroscopic alterations in moribund and dead fish were large reddish-colored skin ulcerations combined with fin rot. Virtually pure cultures of *Aeromonas sobria* were isolated from the liver, kidney, spleen and skin lesions of affected fish. *A. sobria* isolated from the farmed perch appeared as hemolytic colonies when grown on sheep blood agar, auto-aggregated, was cytotoxic for cultured fish cells and possessed genes involved in type III protein secretion [9]. Experimental infection of naïve perch with a single colony isolate of *A. sobria* from an affected farm fish resulted in the development of symptoms identical to those seen on the farm. These findings indicated *A. sobria* was the primary pathogen of the diseased perch [9].

In the current protocol, we describe the development of an immersion vaccine that protects against infection with pathogenic *A. sobria*, arising from the environment or from infected individuals kept in the open perch farm, as an example of the development of a farm-specific vaccine.

2 Materials

2.1 Bacterial Strain

Aeromonas sobria strain JF2635 was isolated from the skin lesion of a diseased perch from a fish farm on a Swiss lake. It was identified phenotypically as *A. sobria* using the API 20NE system (bioMérieux SA, Lyon, France) and genetically by 16S rRNA gene, *rpoB* and *gyrB* DNA sequence analysis. JF2635 was shown to harbor a type III secretion system (T3SS) [9]. This strain is available from the authors.

2.2 Growth Medium

1. T-soy broth (Trypticase Soy Broth) (Becton, Dickinson and Company, Sparks, MD, USA): 30 g Trypticase™ Soy Broth dissolved in 1 L H₂O, autoclave for 15 min at 121 °C. Composition for 1 L T-soy broth: pancreatic digest of casein 17.0 g, papaic digest of soybean 3.0 g, NaCl 5.0 g, K₂HPO₄ 2.5 g, dextrose 2.5 g, add H₂O to 1 L.
2. T-soy agar (Trypticase Soy Agar) (Becton, Dickinson and Company, Sparks, MD, USA): 40 g Trypticase™ Soy Agar dissolved in 1 L H₂O, autoclave for 15 min at 121 °C. Composition for 1 L T-soy agar: pancreatic digest of casein 15.0 g, papaic digest of soybean 5.0 g, NaCl 5.0 g, agar 15.0 g, add H₂O to 1 L.

2.3 Chemicals

1. Formaldehyde 37 % w/v (note: Toxic, Corrosive, Carcinogen category 1) (Merck).
2. PBS buffer sterile; 137 mM NaCl, 2.7 mM KCl, 12 mM Phosphate, pH 7.4 produced by dissolving 8 g NaCl, 0.2 g KCl, 1.42 g Na₂HPO₄, 1.78 g Na₂HPO₄ · 2 H₂O, and 0.27 g KH₂PO₄ per 1 L H₂O and subsequently sterilized for 20 min at 121 °C.

2.4 Equipment

1. Centrifuge with rotor capable of attaining 6000 × *g* (e.g., Sorvall RC5B with rotor GSA).

3 Methods**3.1 Production of the Immersion Vaccine Antigen**

Procedures for the production of the vaccine antigen are carried out at room temperature in a BSL-2 (biosafety laboratory level 2) facility using a laminar flow sterile work bench. Most *Aeromonas* species that are pathogenic to fish, including *A. sobria* strain JF2635, have a maximum growth rate at a temperature of 18 °C. They should not be handled at temperatures above 20 °C for periods extending ½ h, as many *Aeromonas* species isolated from aquatic environments are genetically unstable at temperatures above 20 °C [10, 11].

The following preparation of vaccine is described for 1 L cultures. In order to vaccinate 50,000 fry, 10 culture flasks of 1 L culture are required.

1. Prepare a pre-culture of the respective bacterial strain (in our case *A. sobria* JF2635) on T-soy agar at 18 °C for 2 days.
2. Inoculate 1 L of T-soy broth with the pre-culture using a sterile cotton swab.
3. Grow the liquid culture at 18 °C with gentle shaking for 3 days.
4. Inspect turbidity by diffraction photometry: Apparent OD₄₅₀ should have reached 1.0 or slightly above corresponding to approximately 10⁹ colony forming units (CFU)/mL (*see Note 1*).

5. Centrifuge the liquid culture for 15 min at $6000 \times g$.
6. Discard supernatant and suspend pellet in 10 mL PBS buffer.
7. Add 560 μL formaldehyde (37 %) and incubate at room temperature ($20\text{ }^\circ\text{C}$) for 2 h (*see Note 2*).
8. Centrifuge for 15 min at $6000 \times g$ at $4\text{ }^\circ\text{C}$.
9. Discard supernatant and suspend pellet in 10 mL PBS buffer.
10. Centrifuge for 15 min at $6000 \times g$ at $4\text{ }^\circ\text{C}$.
11. Discard supernatant and suspend pellet in 10 mL PBS buffer \rightarrow vaccine.
12. Store the vaccine (containing 10^{11} *A. sobria*/mL) at $4\text{ }^\circ\text{C}$ for maximum 3 months.
13. Check sterility by plating 50 μL of the suspended bacteria on two plates of blood-agar medium and 50 μL on two plates of T-soy-agar medium. Incubate each a plate at 18 and $30\text{ }^\circ\text{C}$ for 5 days. Ensure absence of growth before releasing the vaccine lot.

3.2 Vaccination of Fry

Posology: immersion vaccination of 1000 g of fry of an average weight of 1–3 g requires 1 mL of the above vaccine containing 10^{11} bacteria/mL (*see Note 3*). Typically 100 kg, approximately 50,000 fry, are vaccinated before being transferred to open fattening cages.

1. Prepare 10 L of water (or an appropriate volume according to needs) at approximately $18\text{ }^\circ\text{C}$ (this should be the same temperature as the fry were grown).
2. Add 100 mL of vaccine.
3. Immerse 5 kg of fry (approximately 2500 fry) for 5 min.
4. Remove fry and transfer to tanks with aerated water or to the fattening cages.
5. Repeat process of immersion of 5 kg of fry to reach a total of 100 kg (50,000 fry).
6. Dispose of the immersion vaccine suspension.

3.3 Vaccine Efficacy

To assess the efficacy of the auto-vaccine, fish weighing an average of 12 g and that had been vaccinated by immersion as fry 12 weeks previously were challenged with live *A. sobria* strain JF2635. Vaccinated fish (10 per group) showed no mortality after intraperitoneal challenge with 10^8 CFU/fish (2 groups), 10^9 CFU/fish (2 groups), and 2×10^9 CFU/fish (2 groups). This is in strong contrast to non-vaccinated perch, which showed a cumulative mortality of 70 % 6 days after intraperitoneal challenge with 10^7 CFU/fish, or 100 % 3 days after challenge with 10^8 CFU/fish of the same strain [9].

An assessment of the efficacy of the auto-vaccine under fish farming conditions was performed on an open pilot perch farm situated on a Swiss lake. The farm consisted of 24 conic net cages floating in the lake, each containing 50,000–80,000 fish. The assessment was carried out during the months of November to February when water temperatures varied from 14 to 5 °C. One fattening cage contained 50,000 fish that were vaccinated as fry at the hatchery 1 week before stocking them in the net cage; ten cages harbored a total of 300,000 unvaccinated fish and the remainder of the cages were empty. Mortality rates were determined daily by collecting dead fish from the bottom of the cages and counting with an electronic device. The results are shown in Fig. 1 and indicate the cumulative mortality rate of the whole fish farm as compared to the cumulative mortality rate of the vaccinated cage. After 4 months of fattening, the cumulative mortality of the whole farm, including the vaccinated fish, reached 66.9 %, while the cumulative mortality in the vaccinated cage reached 3.2 % (Fisher's exact $p < 0.00001$) (Fig. 1).

3.4 Ethical Review

All animal experiments carried out during the development of this vaccine were approved by the Veterinary Office, Canton of Bern.

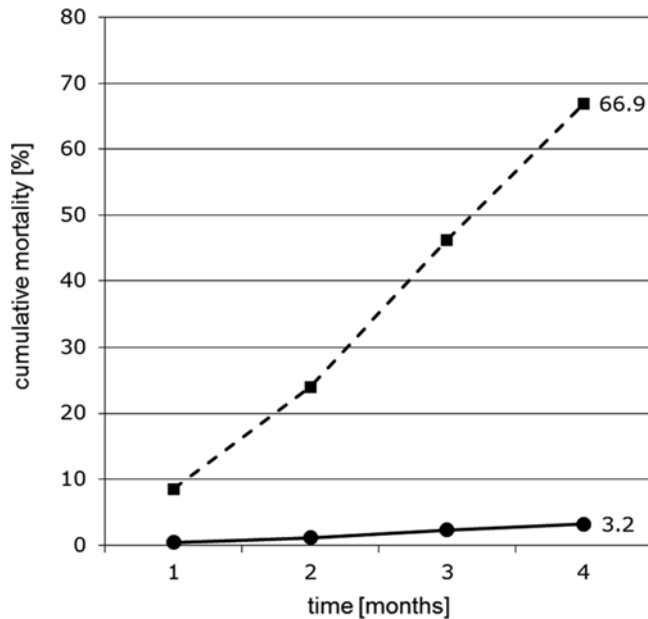

Fig. 1 Cumulative mortality rate of the whole fish farm (350,000 perch in 11 cages including one cage of 50,000 vaccinated fish) as compared to the cumulative mortality rate of the vaccinated cage containing 50,000 perch, measured over 4 months. *Dotted line* whole farm, *solid line* vaccinated cage

4 Notes

1. When working with strains other than the one described in this publication, the correlation of OD₄₅₀ to bacterial concentration needs to be established by determining the CFU/mL.
2. Inactivation of bacteria can also be performed by incubation with 1 % glutaraldehyde under alkaline conditions. The use of glutaraldehyde for the preparation of vaccines offers several advantages, including intrinsic adjuvant action and stability of preparations. Glutaraldehyde is primarily used for detoxification of protein toxins, such as tetanus toxin, and offers short detoxification times. However, glutaraldehyde treatment must be carried out while carefully controlling conditions such as pH, time of contact, temperature, and protein or cell concentration otherwise it can be detrimental to surface epitopes. We have not validated glutaraldehyde in our protocol.
3. The production of large amounts of vaccine for vaccination in large-scale breeding facilities necessitates the use of fermenters or the production of antigens by commercial providers. For our large-scale vaccination, the *Aeromonas sobria* JF2635 vaccine antigen was custom-produced by BIOVAC Angers, France (<http://vaccines.biovac.fr/en/>).

Acknowledgements

We are grateful to Jean-Blaise Perrenoud, Chez le Barth, Switzerland, and to Olivier Mueller, Chavornais, Switzerland for the breeding of the perch and the vaccination of the fry respectively. This work was supported by a grant from KTI/CTI Nr. 7958.1 LSPP-LS.

References

1. WHO (2006) Antimicrobial use in aquaculture and antimicrobial resistance. Report of a joint FAO/OIE/WHO expert consultation on antimicrobial use in aquaculture and antimicrobial resistance. Seoul Republic of Korea. Issued by World Health Organization Geneva, Switzerland
2. Bruderseth BE, Wiulsrød R, Nilsen B et al (2013) Status and future perspectives of vaccines for industrialised fin-fish farming. *Fish Shellfish Immunol* 35:1759–1768
3. Håstein T, Gudding R, Evensen Ø (2005) Bacterial vaccines for fish – an update of the current situation worldwide. In: Mydting PJ (ed) *Progress in fish vaccinology*, vol 121, *Developments in biological standardization*. Karger, Basel, pp 55–74
4. Plant KP, LaPatra SE (2011) Advances in fish vaccine delivery. *Dev Comp Immunol* 35: 1256–1262
5. Bernoth EM (1997) Furunculosis: the history of the disease and of disease research. In: Bernoth EM, Ellis AE, Mydting PJ, Smith P (eds) *Furunculosis multidisciplinary fish disease research*. Academic, London, pp 1–20
6. Roberts R (1993) Motile aeromonad septicemia. In: Inglis V, Roberts RJ, Bromage NR

- (eds) Bacterial diseases of fish. Blackwell Scientific Publications, Oxford, pp 143–155
7. Austin DA, McIntosh D, Austin B (1989) Taxonomy of fish associated *Aeromonas* spp. with the description of *Aeromonas salmonicida* subsp. *smithia* subsp. nov. Syst Appl Microbiol 11:277–290
 8. Toranzo AE, Romalde JL, Magariños B et al (2009) Present and future of aquaculture vaccines against fish bacterial diseases. In: Rogers C (ed) The use of veterinary drugs and vaccines in Mediterranean aquaculture, vol 86. CIHEAM Options Méditerranéennes, Zaragoza, pp 155–176
 9. Wahli T, Burr SE, Pugovkin D et al (2005) *Aeromonas sobria*, a causative agent of disease in farmed perch, *Perca fluviatilis* L. J Fish Dis 28:141–150
 10. Stuber K, Burr SE, Braun M et al (2003) Type III secretion genes in *Aeromonas salmonicida* subsp. *salmonicida* are located on a large thermolabile virulence plasmid. J Clin Microbiol 41:3854–3856
 11. Tanaka KH, Dallaire-Dufresne S, Daher RK et al (2012) An insertion sequence-dependent plasmid rearrangement in *Aeromonas salmonicida* causes the loss of the type three secretion system. PLoS One 7(3):e33725

Prokaryotic Production of Virus-Like Particle Vaccine of Betanodavirus

Junfeng Xie, Runqing Huang, and Yuxiong Lai

1 Introduction

Piscine nodaviruses, the causal agents of viral nervous necrosis or viral encephalopathy and retinopathy, are members of genus *Betanodavirus* under family *Nodaviridae*. Betanodaviruses are small, spherical, non-enveloped viruses with a bipartite single-stranded (+) RNA genome encapsulated by 180 molecules of a single self-assembly capsid protein (CP) [1]. They are important viruses in aquaculture because they can infect more than 39 marine fish species [2], especially high-value fish species, primarily at the larval and juvenile stages [3, 4], which result in mass mortality and serious economic losses.

To efficiently control betanodavirus infections, vaccination is a pivotal strategy and several types of vaccines have been reported. Prokaryotic recombinant CP, synthetic peptides of neutralizing betanodavirus epitopes, DNA vaccine, inactivated virus, and virus-like particles (VLPs) were tested and VLPs are thought to be the most promising vaccine candidate because they can activate humoral immune response and induce cellular and innate immunities post-immunization with small quantities [5]. VLPs can be expressed by the baculovirus [6], yeast [7] or *Escherichia coli* (*E. coli*) [5, 8] system and provide relatively high protective immunity as efficient as inactivated betanodaviruses in several fish species. The structure of OGNNV VLP was revealed by cryo-electron microscopy (Fig. 1) and was found indistinguishable from the native virus on the outer surface [9]. VLPs can be produced eukaryotically and prokaryotically, of which the prokaryotic system is easier to manipulate, has higher yields and is faster and cheaper.

VLPs should be purified from expression host by purification methods after expression. The laboratory purification protocols based on ultracentrifugation on sucrose or cesium chloride density

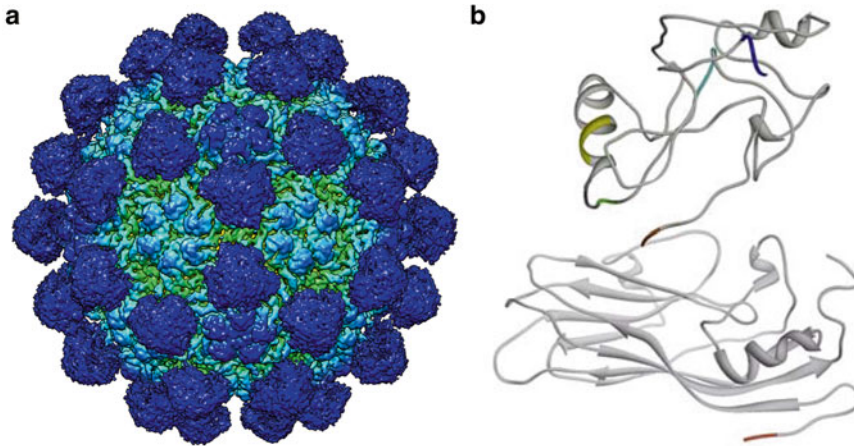

Fig. 1 Structural analysis of OGNNV. **(a)** 3D reconstruction of OGNNV VLP at 3.9 Å. The 3D structure of OGNNV VLP was resolved by cryo-electron microscopy and single particle reconstruction. VLP has a 38 nm in diameter with $T=3$ icosahedral symmetry. There are three chemical identical monomers in each asymmetric unit. The capsid shells are shown in *green* and the protrusions are shown in *blue*. There is a high flexible loop to connect the protrusion to the capsid shell (not shown). **(b)** Structure prediction of CP monomer. We separate CP into three independent domains: the N-terminal domain (N-domain) (residues 1–50), the Shell domain (S-domain) (residues 51–220, the lower part of the structure contains N- and S-domain), and the Protrusion domain (P-domain) (residues 221–338, the *upper part*). N- and S-domains constitute the capsid shell while P-domains form the protrusion. Each protrusion is composed of three P-domains of three VPs in the asymmetry unit. Between S and P domains, there is a high flexible linker loop composed of residues 210–220 functioning as connection (no display). The flexible linker loops make the protrusions have the spatial variation

gradients [10, 11] are labor-intensive, time-consuming, costly, and unsuitable for industrial-scale production. Later, chromatography-based protocols, which are essential for commercial production of the vaccine, were developed. The chromatography is accomplished by the affinity between betanodavirus VLPs and heparin [7].

1.1 Expression System Selection

VLP vaccine can be produced by baculovirus [6, 11], yeast [7] or *E. coli* [5, 8, 10] expression system. The advantages and disadvantages of these three systems are listed in Table 1 as the guide for expression system selection. The *E. coli* system for VLPs expression is presented below.

1.2 Instrument Selection for Prokaryotic Expression

In an incubator shaker, bacteria can be cultured in 500 mL scale in 1-L shaking flask which could be scaled up by increasing the number of flasks. Alternately, a 10-L (or 5-L) bioreactor can be used to culture 7 L (or 3 L) bacteria. Both the instruments can be used to express high quality VLPs and the bioreactor has the advantage of higher production rate (VLP yield/culture volume) and easier operation such as control of temperature and ventilatory capacity. However, the dispersion of VLPs produced in flask is better than that in bioreactor. After expression, the status of CP solubility

Table 1
Selection guide for VLP expression system

Type	Advantages	Disadvantages
Baculovirus	Close to native state, possible posttranslational modification, no endotoxins	Low yield, high cost, long culturing time, complicate operation (cell culture, baculovirus removal)
Yeast	Possible posttranslational modification, no endotoxins	Long culturing time, complicate operation (cell wall disruption, dialysis)
<i>E. coli</i>	Fast, high yield, low cost, easy operation	Contain endotoxins, no posttranslational modification

should be monitored by SDS-PAGE using samples of whole proteins, supernatants, and pellets after sonication.

1.3 Purification Method

The traditional purification method for betanodavirus VLPs is the same as wild-type virus, that is, density gradient ultracentrifugation [5, 10, 11]. Although this laboratory purification protocol is not suitable for industrial-scale vaccine production, it can yield high concentration of VLPs with high quality. Chromatography-based protocol is suitable for the purification of large amounts of VLPs for vaccine production [7]. But the concentration of resulting VLPs is lower than that obtained by ultracentrifugation method and the VLPs should be concentrated after dialysis.

1.4 VLP Verification

The concentration and purity of the resulting VLPs can be detected by SDS-PAGE and BCA protein assay kit. The structural completeness of virions should be evaluated by electron microscopy after negative staining.

2 Materials

2.1 Bioinformatics Analysis and Primer Design

1. Sequence analysis and design software (e.g., VectorNTI, Life Technologies, Grand Island, NY, USA; DNASTar, LaserGene System, DNASTAR, Inc., Wisconsin, USA).
2. National Center for Biotechnology (NCBI) BlastN online server [12].
3. Primer synthesis Contract Research Organization (CRO) (e.g., BGI, Shenzhen, Guangdong, China; GenScript, Piscataway, NJ, USA).

2.2 PCR

1. Synthetic primers and CP gene (accession number: AF534998) from cDNA of OGNNV RNA2.
2. dNTP mixture containing dATP, dTTP, dCTP, dGTP (10 mM each).

3. pfu DNA polymerase and 10× PCR reaction buffer.
4. PCR machine: Gene Technologies Ltd, G-STORM or equivalent.
5. Agarose, 6× loading dye, DNA molecular standard with band of 1 kb, and nucleic acid stain suitable for gel electrophoresis.
6. Agarose gel electrophoresis system: for 150 mL of 1.0 % agarose gel, use 1.5 g of ultrapure agarose (electrophoresis grade) with 150 mL of 1× TAE. Prepare 1 L of 10× TAE stock solution in ultrapure H₂O with 48.4 g of Tris base, 3.72 g disodium EDTA, and adjust to pH 8.5 with glacial acetic acid.
7. Gel documentation system.
8. QIAquick Gel Extraction Kit (Qiagen).

2.3 Expression Vector Cloning

1. pQE30 vector, Qiagen.
2. Restriction enzymes: *EcoRI*, *HindIII* and 10× buffer suitable for single or double digestion.
3. T4 DNA ligase and 10× ligase buffer.
4. CaCl₂ treated competent cell: *E. coli* DH5α or XL1-Blue for selection and propagation of recombinant vectors.
5. LB medium: To 700 mL of distilled H₂O add 10 g tryptone, 5 g yeast extract, and 10 g NaCl. Adjust to 880 mL with distilled H₂O. Sterilize by autoclaving and store up to 3 months at room temperature.
6. SOC medium: To 900 mL of distilled H₂O add 20 g Bacto tryptone, 5 g Bacto yeast extract, 2 mL of 5 M NaCl, 2.5 mL of 1 M KCl, 10 mL of 1 M MgCl₂, 10 mL of 1 M MgSO₄, 20 mL of 1 M glucose. Adjust to 1 L with distilled H₂O. Sterilize by autoclaving and store up to 3 months at room temperature.
7. Falcon® 60 mm culturing dish, sterile.
8. Incubator for bacteria growth at 37 °C.
9. Sterile inoculation loops.
10. 14 mL round-bottom snap-cap tubes, sterile.
11. Shaking incubator for growth of liquid cultures at 37 °C.
12. 50 % glycerol (wt./vol.): Sterilize by autoclaving and store at room temperature for several months.
13. Sterile cryovials.
14. QIAquick Gel Extraction Kit (Qiagen).
15. Plasmid miniprep kit: Qiagen Qiaprep miniprep kit or equivalent.
16. UV spectrophotometer for determination of nucleic acids concentration.

2.4 Prokaryotic Expression

1. CaCl₂ competent cell: *E. coli* M15 for expression of recombinant vectors.
2. LB medium: To 700 mL of distilled H₂O add 10 g tryptone, 5 g yeast extract, and 10 g NaCl. Adjust to 880 mL with distilled H₂O. Sterilize by autoclaving and store up to 3 months at room temperature. Add ampicillin to final concentration of 100 µg/mL before use.
3. 1 M IPTG: To 9 mL of distilled H₂O add 2.4 g isopropyl-beta-D-thiogalactoside powder (Sigma), adjust to 10 mL with distilled H₂O and sterilize by filtration.
4. 100 mM PMSF: To 10 mL of isopropanol add 0.174 g phenylmethanesulfonyl fluoride (PMSF), mix well and store at -20 °C.
5. 1× PBS (pH 8.0): Dissolve 8 g NaCl, 0.2 g KCl, 1.44 g Na₂HPO₄ and 0.27 g KH₂PO₄ in 800 mL ultrapure H₂O, adjust pH to 8.0 with HCl, bring volume to 1 L, autoclave and store at room temperature.
6. PBST: To 200 mL of PBS (pH 8.0) add 2 mL of Triton X-100 and 4 mL of 100 mM PMSF to make 1 % PBST with 2 mM PMSF. Prepare freshly before use.
7. Spectrophotometer for determination of bacterial cell density.
8. Beckman Coulter® 50 mL, 500 mL centrifuge tube, sterile.
9. Falcon® 60 mm culturing dish, sterile.
10. Incubator for bacteria growth at 37 °C.
11. Sterile inoculation loops.
12. 14 mL round-bottom snap-cap tubes, sterile.
13. Shaking incubator for growth of liquid cultures at 37 °C.
14. 50 % glycerol (wt./vol.): Sterilize by autoclaving and store at room temperature for several months.
15. Sterile cryovials.
16. Centrifuge: for 15, 50, and 500 mL.
17. Sonicator.

2.5 Ultracentrifuge Purification

1. 10 %, 20 %, 30 %, and 40 % (w/w) sucrose buffer: To 90 g, 80 g, 70 g, and 60 g of distilled H₂O add 10 g, 20 g, 30 g, and 40 g sucrose, respectively, and stir to resolve. Sterilize by filtration and store at room temperature.
2. 1× PBS (pH 8.0).
3. Long metal needle (16#, 150 mm) and syringe (5 mL).
4. Beckman Coulter® 14 mL Ultra-clear ultracentrifuge tube.
5. Beckman Coulter® Optima L-100XP ultracentrifuge or equivalent.

2.6 VLP Confirmation

1. 30 % Acrylamide-BIS: Dissolve 29 g acrylamide and 1 g *N,N'*-methylenebisacrylamide (BIS) in 70 mL deionized H₂O with gentle stirring, bring to 100 mL and sterile by filtration. Store at 4 °C and protect from light.
2. 10 % (w/v) SDS: Dissolve 10 g SDS in 90 mL deionized H₂O with gentle stirring and bring to 100 mL. Store at room temperature.
3. 1.5 M Tris-HCl (pH 8.8): Dissolve 27.23 g Tris base with 80 mL deionized H₂O, adjust to pH 8.8 with 6 N HCl, bring total volume to 150 mL and store at 4 °C.
4. 0.5 M Tris-HCl (pH 6.8): Dissolve 6 g Tris base with 60 mL deionized H₂O, adjust to pH 6.8 with 6 N HCl, bring total volume to 100 mL and store at 4 °C.
5. 10 % (w/v) APS (fresh daily): Dissolve 100 mg ammonium persulfate in 1 mL of deionized H₂O.
6. 5× electrode (running) buffer: Dissolve 15.1 g Tris base, 94 g glycine, and 5 g SDS in 800 mL deionized H₂O with gentle stirring, bring to 100 mL and store at 4 °C. Dilute to 1× electrode buffer with deionized H₂O before use.
7. 4× SDS sample (loading) buffer: To 1 mL deionized H₂O add 8 mg bromophenol blue, 2 mL of 1 M Tris-HCl (pH 6.8), 0.8 mL of 10 % SDS, and 4 mL of glycerol, mix well and bring to 10 mL. Make aliquots of 950 μL each and freeze at -20 °C. Before use add 50 μL of 14.7 M β-mercaptoethanol to each tube. For final application take one part of 4× sample buffer and three parts of protein sample.
8. Coomassie brilliant blue staining buffer: Dissolve 1.25 g Coomassie brilliant blue R-250 in 250 mL methanol, add 50 mL acetic acid, and bring to 500 mL with deionized H₂O. Store at 4 °C.
9. JOEL JEM-1400 electron microscope or equivalent.
10. 2 % phosphotungstic acid for negative staining.

3 Methods

The primers are designed (Subheading 3.1), *cp* gene is amplified (Subheading 3.2) and cloned (Subheading 3.3), VLP is expressed in bacteria (Subheading 3.4), purified by ultracentrifugation (Subheading 3.5) and verified (Subheading 3.6). The overall procedure is shown in Fig. 2.

3.1 Bioinformatics Analysis and Primer Design

1. Based on the DNA sequence of betanodavirus *cp* gene, primers is designed to amplify *cp* gene with overhang restriction endonuclease cutting sites. To ensure that the used endonucleases

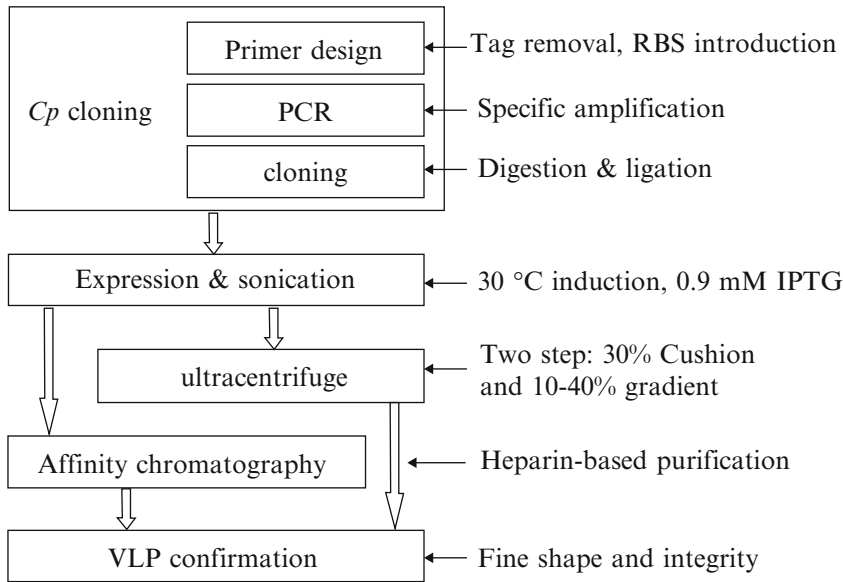

Fig. 2 The flowchart of *cp* cloning and VLP expression

cannot be found in *cp* gene. The examples here are *Eco*RI site for forward primer (F) and *Hind*III site for reverse primer (R).

- The ribosome binding site (RBS, 5'-ATTAAAGAGGAGAA ATTA ACT-3') is added to F primer between the *Eco*RI site and the AUG codon of *cp* gene to eliminate the original RBS and RGS·polyhis epitope of pQE30. The R primer is containing the stop codon (TAA) of *cp* gene. At the 5 prime of the restriction sites, certain bases are added to ensure efficient DNA cleavage by *Eco*RI (CG) and *Hind*III (CCC). That is, the final sequence of the F and R primers are, F:5'-CGGAAT TCATTAAAGAGGAGAAATTAAC **Tat**ggtagcgaaggtgagaag-3', R: 5'-CCCAAGCTT **tt**agttttccgagtcacacctg-3' (The underlined bases are endonucleases cutting sites. The circled bases are RBS sequence. The lowercase bases are *cp* gene sequence required for PCR with bolded ATG and TAA codon).
- Check the sequences of the primers, compare the homology to eliminate the nonspecific amplification, detect the secondary structure of the primers, and predict the annealing temperature in PCR.
- Send the primers for synthesis.

3.2 PCR

- Primers are diluted with sterile ultrapure H₂O to get the final concentration of 10 μM.
- Assemble the pilot PCR reaction in 20 μL as shown in Table 2. Tap the PCR tube to mix the reaction and spin down the liquid to the bottom. Put the tube into the PCR machine.

Table 2
PCR reaction

Component	20 μ L reaction	100 μ L reaction	Thermocycling conditions
H ₂ O	15.2	76	
dNTP (10 mM each)	0.4	2	94 °C 3 min
MgCl ₂	0.8	4	94 °C 30 s 30 cycles
F primer (10 μ M)	0.4	2	55 °C 30 s
R primer (10 μ M)	0.4	2	72 °C 80 s
Template (cp gene)	0.4 (<1 μ g)	2 (<5 μ g)	72 °C 5 min
10 \times pfu buffer	2	10	
pfu DNA polymerase	0.4	2	

3. Set and run the PCR program as shown in Table 2 (*see Note 1*).
4. After the reaction, load the PCR product on agarose gel and resolve. After 10–15 min, photograph the gel image by gel documentation system.
5. Determine the yield of PCR product (*see Note 2*) and carry out large scale PCR reaction (100 μ L) to obtain plenty of PCR product.
6. Load all the reaction solution on agarose gel, resolve and gel-purify PCR product using the QIAQuick kit, eluting DNA fragment with 50 μ L of sterile pure H₂O.
7. Detect the DNA concentration in the final solution by using nano-volume UV spectrophotometer.

3.3 Expression Vector Cloning

1. Digest 1 μ g of pQE30 vector and 2 μ g of purified fragment with appropriate enzymes (*Eco*RI and *Hind*III here) (*see Note 3*). Inactivate the enzymes by heating to 65 °C for 20 min.
2. Load restriction digests on agarose gel, resolve and gel-purify vector and insert fragments using the QIAQuick kit, eluting fragments with 30 μ L of elution buffer.
3. Detect the DNA concentration in the final solution by spectrophotometer.
4. Set ligation reaction. Typically, for a 12 μ L ligation, 3 μ L of the gel-purified vector (about 100 ng) and 7 μ L of the purified insert are mixed with 1.2 μ L of 10 \times ligation buffer and 0.8 μ L of T4 DNA ligase. The ligation is incubated overnight at 16 °C and then heat-killed at 65 °C for 20 min.
5. All the ligation products are added to 100 μ L CaCl₂ treated DH5 α competent cell and mix cells by tapping the microcen-

trifuge tube gently. After chilling on ice for 30 min, put the tube to 42 °C water bath for 90 s and then immediately transfer the tube on ice for at least 3 min. Add 900 µL prewarmed SOC medium to the tube and shake vigorously at 200 rpm in a shaking incubator for 30 min at 37 °C. Aseptically spread 100 µL of transformation outgrowth on LB plate with ampicillin (100 µg/mL). Invert and put the plate in incubator at 37 °C overnight.

6. Carry out colony PCR to detect the recombinants. Set up 200 µL PCR mastermix for 10 reactions using the sequencing primers of pQE30 (pQE30-F: 5'-TGAGCGGATAACAATTTCAC-3', pQE30-R: 5'-GTTCTGAGGTCATTACTGG-3') and no template is needed. Equally deliver the solution into ten PCR tubes (20 µL each). Select and label eight single colonies on the plate, then use a sterile plastic toothpick to pick a part of each colony and inoculate into the 20 µL reaction (*see Note 4*). Including the positive (*see Note 5*) and negative controls (no colony added), ten tubes of reactions are put into the PCR machine to perform colony PCR (*see Note 6*). Identify the recombinant colonies by finding a band around 1 kb in DNA gel electrophoresis.
7. Using sterile inoculation loops, pick each confirmed colony and aseptically inoculate each into a 3 mL culture of LB/ampicillin medium in a 14 mL snap-cap tube. Grow the cultures by shaking vigorously at 220–250 rpm in a shaking incubator at 37 °C for 12–16 h. Isolate plasmid DNA from the cultures and determine plasmid DNA concentration by spectrophotometry.
8. Further identify recombinant clones with correct insert size by restriction digestion (*see Note 7*). Validate recombinant plasmid by sequencing using pQE30 sequencing primers.
9. Grow culture of one validated clone to make glycerol stocks and isolate plasmid for expression.
10. Prepare M15 *E. coli* competent cell using CaCl₂. Transform the recombinant plasmid into M15.

3.4 Prokaryotic Expression and Sonication

1. If needed, pilot expression can be performed to select a productive colony (*see Note 8*). Grow the selected colony in medium to make glycerol stocks and seed culture.
2. A volume of 80 mL seed culture grows overnight by shaking vigorously at 220–250 rpm in a shaking incubator at 37 °C.
3. The seed culture is inoculated equally into eight 2-L flasks of 1 L LB/ampicillin medium (totally 8 L) and grow at the same condition when the cell density reaches 0.3–0.4 (OD₆₀₀).
4. Cool down the culture to 30 °C (*see Note 9*) and save 100 µL culture as uninduced sample (negative control).

5. Expression induction. To each flask add 0.9 mL of 1 M IPTG to make final concentration of 0.9 mM for induction. After induction for 2 h at 30 °C, cells in 1 L culture are repeatedly collected by centrifuged at $5000\times g$ for 20 min in one 500-mL centrifuge tube and the supernatant is discarded.
6. Resuspend the pellet from 1 L culture by 10 mL cold PBST. Save 30 μ L as whole cell expressed sample.
7. Sonicate the resuspended solution on ice for totally 30 min with repetition of a 6 s burst at 250 W and a 5 s cooling period (*see Note 10*). Check the status of the solution every 5 min. The lysate will become clear from viscous if sonication is accomplished.
8. After sonication, centrifuge at $15,000\times g$ at 4 °C for 20 min. Transfer the supernatant containing VLPs to a new tube, resuspend the pellet with 5 mL PBS and save 50 μ L as insoluble sample. For the supernatant, repeat centrifugation for two more times and save 50 μ L as soluble sample.
9. Boil, resolve and evaluate four collected samples (uninduced, whole cell expressed, insoluble and soluble) by SDS-PAGE to confirm CP expression status (*see Note 11*).

3.5 Ultracentrifuge Purification

1. Add 3 mL 30 % sucrose to a fresh 14 mL ultracentrifuge tube as a cushion, overlay 10 mL of collected supernatant, and counterbalance the tubes with PBS (pH 8.0). The tubes are centrifuged at $250,000\times g$ at 4 °C for 1 h. The pellet containing VLP is resuspended in 1 mL of PBS.
2. Prepare 10–40 % (w/w) sucrose gradient in 14 mL ultracentrifuge tube. Add 3 mL of 10 % sucrose to the tube, and then slowly add 3 mL of 20 % sucrose directly at the bottom of the tube using long metal needle and syringe, avoiding disturbance of the interface of two layers of sucrose in different concentrations. Then, the layer of 10 % sucrose is lifted on top while the layer of 20 % sucrose is at the bottom. By means of the same method, add 30 and 40 % sucrose in turn to make the sucrose gradient of 10–40 % from top to bottom of the tube (*see Note 12*).
3. Overlay 2 mL of resuspended solution (from 2 L of medium) on the top of one tube of sucrose gradient and totally prepare four tubes of gradient for 8 L of original culture. Counterbalance the ultracentrifuge tubes and centrifuge at $250,000\times g$ at 4 °C for 3 h.
4. Fractionate the gradient from top, every 500 μ L as a fraction. Normally 24–28 fractions are collected.

3.6 VLP Confirmation

1. The shape, size, and integrity of the VLPs in each fraction are confirmed by negative staining and electron microscopy (*see Note 13*).

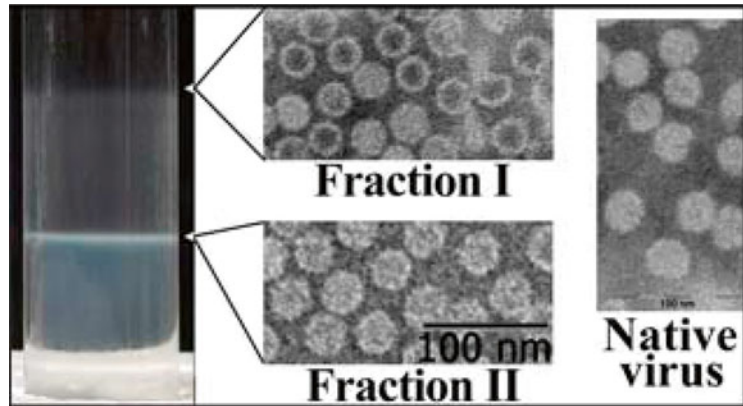

Fig. 3 Sucrose gradient purification and VLP electron microscopy. Two fractions of VLPs (F I and F II) were observed in sucrose gradient purification. Electron microscopy of negatively stained VLPs (including fraction I and II) and OGNV (WT) are shown (bar = 100 nm)

2. The fractions containing fine structured (Fig. 3) and highly pure VLPs are diluted with PBS and centrifuged at $250,000 \times g$ for 1 h to remove the sucrose. The pellets containing VLPs are resuspended with 500 μL of PBS.
3. Determine the concentration of VLPs by SDS-PAGE comparison or BCA.
4. Aliquots 50 μL of the purified VLPs in 200- μL tubes and store at -80°C until use.

4 Notes

1. The annealing temperature in PCR program is determined by the melting temperature (T_m) of primers. The start temperature can be set to 55°C . For pfu taq polymerase, the speed of amplification is normally 800–1000 bp/min. Therefore, extension time is set to 60 s for *cp* gene (1017 bp). The program can be optimized according to the performance of the polymerase.
2. Based on comparing to the intensity of bands in DNA ladder, the quantity of PCR product can be roughly calculated by gel analysis software. For example, there is 122 ng of the 1000-bp band in 1 μg of the 2-Log DNA Ladder (NEB).
3. The digestion should be performed strictly according to the manufacturer's instructions. More than optimum levels of endonuclease or unsuitable buffer will probably show star activity.
4. Colony PCR is a simple and quick method to detect recombinant colonies growing on culturing plate. It saves time and effort

compared to endonuclease digestion because there is no need to grow bacteria in liquid medium and extract plasmid. However, the selected colonies should be saved a part on the plate for the next pick-up if needed. Furthermore, the PCR should be performed using the primers different with the cloning primers, avoiding the false positive mediated by detecting the overdose inserts on the plate.

5. A verified recombinant pQE30 plasmid with an insert larger than 500 bp.
6. The PCR program is similar to that in Table 2 except that the first step of high temperature is set to 94 °C 5 min to break the cells completely.
7. After colony PCR, the selected recombinant colonies can also be identified by endonuclease digestion. Nevertheless, the selected recombinant colonies can be directly sent for sequencing without digestion.
8. In pilot expression, 8–12 colonies are selected to perform small volume (3 mL) expression. By evaluating the banding result of SDS-PAGE, choose the colony with highest yield of CP expression.
9. Before adding IPTG, it is important to cool down the culture to or below 30 °C. The CP monomer is not easy to assemble fine structure VLP over 30 °C. Because of the mass volume, the culture is not easy to cool down quickly when removing the flask from the shaker.
10. The sonication time and stop interval can be adjusted according to different sonicators. However, enough interval should be ensured to avoid protein denature mediated by overheated solution.
11. The yield of VLP is about 15 mg/L. If the quantity of CP in supernatant is enough, the purification step can be performed. If not, make another batch of expression and combine the soluble lysates for subsequent purification.
12. When preparing handmade sucrose gradient, pay attention not to disturb the interface of different layers. Alternately, the gradient can be prepared by machine, such as Biocomp Gradient Master 108, according to the instruction of the manufacturer.
13. There are two bands containing VLPs at a density of 1.07 g/cm³ (fraction I) and 1.13 g/cm³ (fraction II) in the ultracentrifuge tube (Fig. 3). The size of VLPs in fraction II is between 28 and 32 nm while the VLPs in fraction I are smaller (20–25 nm). The shape and integrity of VLPs in fraction II were better than that in fraction I and were more close to that of native virus. Therefore, the high quality VLPs with fine icosahedral structure in fraction II are what we need.

Acknowledgements

This chapter describes work supported by the Fundamental Research Funds of China for the Central Universities (No. 3161079); the State Scholarship Fund of China (No. 2008109931); The National Science and Technology Pillar Program of China (2007BAD29B05).

References

1. Schneemann A, Ball LA, Delsert C, Johnson JE, Nishizawa T (2004) Family Nodaviridae. In: Fauquet CM, Mayo MA, Maniloff J, Desselberger U, Ball LA (eds) Virus taxonomy, eighth report of the international committee on taxonomy of viruses. Academic, London, pp 865–872
2. Nakai T, Mori K, Sugaya T, Nishioka T, Mushiake K, Yamashita H (2009) Current knowledge on viral nervous necrosis (VNN) and its causative betanodaviruses. *Isr J Aquacult-Bamid* 61:198–207
3. Mori KI, Nakai T, Muroga K, Arimoto M, Mushiake K, Furusawa I (1992) Properties of a new virus belonging to nodaviridae found in larval striped jack (*Pseudocaranx dentex*) with nervous necrosis. *Virology* 187:368–371
4. Munday BL, Kwang J, Moody N (2002) Betanodavirus infections of teleost fish: a review. *J Fish Dis* 25:127–142
5. Lai YX, Jin BL, Xu Y, Huang LJ, Huang RQ, Zhang Y, Kwang J, He JG, Xie JF (2014) Immune responses of orange-spotted grouper, *Epinephelus coioides*, against virus-like particles of betanodavirus produced in *Escherichia coli*. *Vet Immunol Immunopathol* 157:87–96
6. Thiery R, Cozien J, Cabon J, Lamour F, Baud M, Schneemann A (2006) Induction of a protective immune response against viral nervous necrosis in the European sea bass *Dicentrarchus labrax* by using betanodavirus virus-like particles. *J Virol* 80:10201–10207
7. Choi YR, Kim HJ, Lee JY, Kang HA, Kim HJ (2013) Chromatographically-purified capsid proteins of red-spotted grouper nervous necrosis virus expressed in *Saccharomyces cerevisiae* form virus-like particles. *Protein Expr Purif* 89:162–168
8. Liu W, Hsu CH, Chang CY, Chen HH, Lin CS (2006) Immune response against grouper nervous necrosis virus by vaccination of virus-like particles. *Vaccine* 24:6282–6287
9. Xie J, Li K, Gao Y, Huang R, Lai Y, Shi Yan, Yang S, Zhu G, Zhang Q, He J (2015) Structural analysis and insertion study reveal the ideal sites for surface displaying foreign peptides on virus-like particle of a betanodavirus. *Vet Res* (Accepted)
10. Lu MW, Liu WT, Lin CS (2003) Infection competition against grouper nervous necrosis virus by virus-like particles produced in *Escherichia coli*. *J Gen Virol* 84:1577–1582
11. Lin CS, Lu MW, Tang L, Liu WT, Chao CB, Lin CJ, Krishna NK, Johnson JE, Schneemann A (2001) Characterization of virus-like particles assembled in a recombinant baculovirus system expressing the capsid protein of a fish nodavirus. *Virology* 290:50–58
12. Boratyn GM et al (2013) BLAST: a more efficient report with usability improvements. *Nucleic Acids Res* 41:W29–W33

Design and Construction of Shrimp Antiviral DNA Vaccines Expressing Long and Short Hairpins for Protection by RNA Interference

Aparna Chaudhari, Gireesh-Babu Pathakota, and Pavan-Kumar Annam

1 Introduction

DNA vaccines are essentially recombinant plasmid constructs capable of expressing pathogen-derived antigenic proteins that prime the host against future infection when administered intramuscularly or subcutaneously [1–3]. DNA vaccines present the aquaculture industry with an effective and economically viable method of checking the threat of various pathogens that drastically affect productivity. They are considered safer compared to live, attenuated, and whole inactivated vaccines and are more stable than protein/glycoprotein subunit vaccines. However, it is for the viral and parasitic diseases that they are particularly attractive options [4]. The DNA vaccine against infectious hematopoietic necrosis virus (IHNV) that affects salmonid fishes is most effective and the only one licensed for use in aquaculture since 2005 [5]. In invertebrates like shrimps, however, the specific immune response system is rudimentary [6] and although there are some reports on application of subunit vaccines [7, 8] and DNA vaccines expressing viral proteins [9], they are of limited efficacy. The discovery of RNA interference (RNAi) pathway in shrimps provided a promising new approach to vaccination, and in current times, the definition of DNA vaccines can be extended to include plasmid constructs that express short or long double stranded RNA (dsRNA) in the host and inhibit pathogen proliferation through RNA interference mechanism.

In a dramatic discovery in 1998 it was found that dsRNA introduced into a eukaryotic cell results in silencing of the corresponding RNA transcript [10], a phenomenon that has been named

“posttranscriptional gene silencing” (PTGS) or “RNA interference” (RNAi). The presence of dsRNA in the cytoplasm (whether it is transfected or synthesized within the cell) triggers the multidomain ribonuclease III enzyme Dicer [11]. This cleaves dsRNA into small interfering RNAs (siRNAs), which are 21–23 nucleotide fragments with characteristic 2-nucleotide 3′ overhangs. These siRNAs are recognized by the RNA-Induced Silencing Complex (RISC; [12]), a multienzyme unit that brings about separation of the two siRNA strands. The antisense siRNA strand remains bound to RISC, while the sense strand is released. In some organisms that have functional RNA-dependent RNA polymerase (RdRp) enzyme, the sense strand may be again converted into dsRNA [13]. The antisense strand guides RISC to bind the homologous (target) mRNA, and another RNase III Argonaute that is part of the complex cleaves it, silencing its expression [14]. The efficiency of siRNA depends on perfect complementarity of the seed sequence (positions 2–6) with the target mRNA. It has been reported that imperfect base pairing that creates a bulge in miRNA/siRNA marks the transcript for translational repression, while a bulge in the mRNA does not prevent cleavage [15]. It has recently been suggested that translational inhibition involves mRNA decapping that ultimately leads to its degradation in P bodies [16, 17].

PTGS, which perhaps evolved as a defense mechanism against RNA viruses [18], has been shown to exist in several plants and animals [19, 20]. The discovery of small genes coding for microRNA (miRNA; short hairpin shaped RNA molecules) that target specific mRNA transcripts also shows that the phenomenon is used to regulate gene expression [21, 22]. RNA interference caught the imagination of researchers all over the world as it opened a completely new box of molecular tools and applications. Aquaculture sector has not remained untouched by this excitement and several attempts are being made to check shrimp viral pathogens [23, 24] by triggering RNAi through exogenous antiviral long dsRNA and siRNA [25–29], or plasmid DNA constructs capable of expressing these molecules in vivo [30, 31]. The presence of Dicer gene has been reported in a number of decapods including *Penaeus monodon* [32, 33], *Litopenaeus vannamei* [34, 35], *Fenneropenaeus chinensis* [36] *Marsupenaeus japonicas* [37, 38], confirming the presence of a functional RNAi pathway.

The fate of plasmid DNA administered to fish by intramuscular/intraperitoneal injection, gene gun or orally has been explored by various researchers in salmon [39–42], Atlantic cod [43], rainbow trout [44–46], marine tiger shrimp *Penaeus monodon* [9, 30]. In fish, despite degradation at the site of administration and in blood plasma, cellular uptake and wide tissue distribution of the plasmid DNA has been observed by PCR, fluorescent in situ hybridization (FISH), isotope and fluorescent labeling [47]. Nevertheless, no histopathological damage was detected in rain-

bow trout up to 2 years after DNA vaccination against IHNV [48]. Detailed reports are not available from shrimp, but plasmid DNA vaccine injected intramuscularly between second and third abdominal segments could be amplified from several tissues after 30 days [30] and injected plasmid was shown to persist up to 2 months [9]. Das et al. [31] could observe no difference in growth rates of *P. monodon* treated with DNA vaccine expressing antiviral lhRNA.

There are several ways by which siRNA could be generated to silence a target gene using RNA interference technology. These include chemical methods where a 21 nt dsRNA is obtained by chemical synthesis or in vitro transcription and biological methods where a long or short hairpin RNA is generated from a plasmid vector in vivo that eventually is cleaved into 21 nt siRNA by dicer. Although siRNA has been the prime choice for gene silencing among several researchers across the globe, long hairpin RNA has the advantage that Dicer can act on it to generate a number of different siRNAs ensuring a robust RNAi effect [49–51]. In addition, it considerably reduces the chances of viral escape by point mutation [52]. The use of long dsRNA is avoided in mammals where it is known to induce a nonspecific interferon response leading to inhibition of protein translation [53], but it is possible in invertebrates and plants [54, 55], where interferons have not been detected [56]. The convenience of producing lhRNA/shRNA in vivo using host machinery cuts down the cost of production compared to chemical synthesis and in vitro transcription methods. Therefore, plasmid DNA constructs designed to express lhRNA/shRNA in vivo can be used as DNA vaccines.

1.1 Target Gene Selection

The choice of target viral gene is critical and its silencing should inhibit viral spread without causing any deleterious effect to the host organism [57]. If silencing of a single viral gene does not provide sufficient protection against infection, multiple viral genes can be targeted in a combinatorial RNAi therapy [58]. This approach can also prevent viral escape through point mutation [59] and it is noteworthy that RNA viruses accumulate point mutations up to 10^7 -fold more rapidly than DNA viruses [60]. However, the dose of RNAi molecules should be regulated so as not to saturate/overload the endogenous RNAi pathway with too many siRNAs [57]. In some cases it is also possible to target host factors that are essential for viral propagation, provided host cell viability is not affected [24].

1.2 Identification of Target Sequence and Design

Characteristics of the specific sequence to be targeted within a selected gene have been suggested [61]. Broad guidelines include the following: (1) confirmation of sequence uniqueness by BLAST homology tool to prevent off-target effects; (2) the sequence must be conserved among different strains reported for a particular virus; (3) the selected sequence must have an optimal thermodynamic profile for incorporation into the RISC as a guide strand

The most effective siRNAs have a relatively low T_m and duplex stability (less stable, more A/U rich) toward the 5'-end of the guide strand and a relatively high T_m (more stable, more G/C rich) toward the 5'-end of passenger strand [61]; (4) the sequence should lie in the coding region, 50–75 bp away from the 5' and 3' ends [62, 63]; (5) mutation prone regions should be identified if possible and avoided. Many free online web tools are available for designing optimal RNAi molecules (e.g., E-RNAi: <http://e-rnai.dkfz.de>, Arziman et al. [64]). The software predicts siRNA efficiency using an algorithm described by Reynolds et al. [65].

1.3 Vector Selection

The selection of plasmid vector depends on the choice of promoter to be used for the expression of sh/lh RNA. Several vectors designed specifically for RNAi studies are commercially available (*see* Subheading 4). Generally, pol III promoters such as U6 and H1 are used for expressing shRNA constructs as they are compact, support high levels of transcription and initiate transcription at a defined starting point. Transcription terminates at a stretch of thymidines and 3' terminus of the hairpin resembles a pre-miRNA. They express constitutively in cell culture, but expression from H1 is associated with dividing cells *in vivo*. There are no tissue specific pol III promoters that might be desirable for some transgenics. In such cases, use of pol II tissue specific promoters is a better option. Some constitutive pol II promoters that are active in shrimp include cytomegalovirus immediate early promoter (CMVp), β -actin and SV40 early promoters [66]. CMVp cannot be used for shRNA vectors as they append 5' vector sequences and 3' poly A sequences, which inhibit shRNA function, but are ideal for lhRNA constructs. For shRNA expression, pol III promoters like U6 and H1 are generally used. Bidirectional promoter constructs with U6 and H1 promoters are also developed for expressing two different shRNA molecules targeting two different genes or two gene segments of a particular gene of interest in order to increase the efficiency of targeted gene silencing (*see* Subheading 4).

Since a vaccine is intended for commercial use selection markers present an important consideration. Antibiotic markers are discouraged by regulatory authorities and it is wise to opt for non-antibiotic selection markers [67, 68]. Centre for Biologics Evaluation and Research (CBER), USA permits the use of kanamycin selection because resistance to this antibiotic is widespread [69].

1.4 Cloning Strategy

In case of lhRNA, the selected portion of the target viral gene is PCR amplified using specific linker primers containing appropriate restriction enzyme (RE) recognition sites for directional cloning in the vector of choice. The same fragment is cloned in reverse orientation leaving a spacer region of 5–7 bp for formation of hairpin loop (Fig. 1). Short-hairpin RNAs, on the other hand, are short stem-looped RNAs of size 19–23 bp. In this case, the complementary

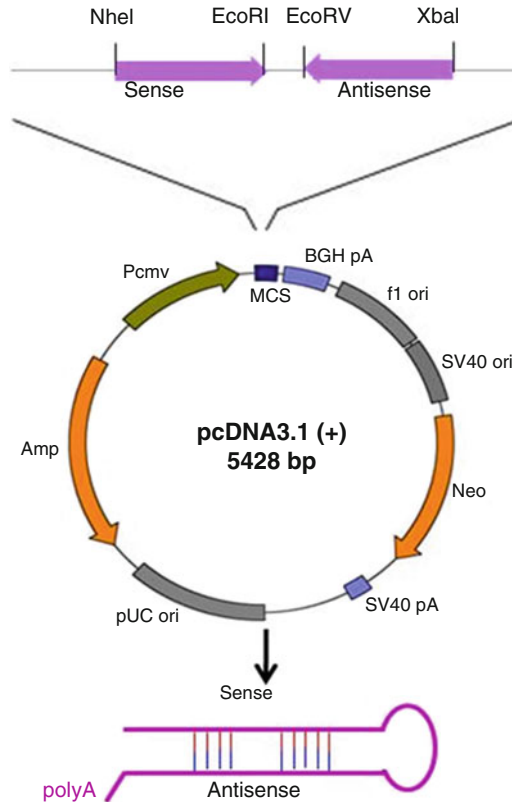

Fig. 1 Schematic diagram of lhRNA expression plasmid

strands can be synthesized and allowed to anneal at room temperature. The resulting cassette is designed to have appropriate overhangs to allow directional cloning in the selected vector (Fig. 2).

1.5 Assessment of Silencing Efficiency

Silencing efficacy of sh/lhRNA constructs can be tested in vitro before commencing the in vivo pathogen challenge studies. Here, the host cells are co-transfected with a plasmid that constitutively expresses the target gene and the sh/lhRNA construct. The silencing efficiency of the RNAi constructs can be estimated at transcript level by real-time PCR of the target gene and at protein level by ELISA. It is best to carry out these studies in shrimp primary cell cultures or cell lines. Although primary cultures could be developed from different tissues of shrimp [70], cell lines are yet to be developed. Other invertebrate cell lines like those derived from insects, *C. elegans*, etc. (Sf9, Sf21, and *Drosophila* S2) can also be used. In vertebrates, lhRNA is known to induce nonspecific interferon response leading to inhibition of protein translation in general [54, 55] and this phenomenon may account for some silencing effect if vertebrate cell lines are used.

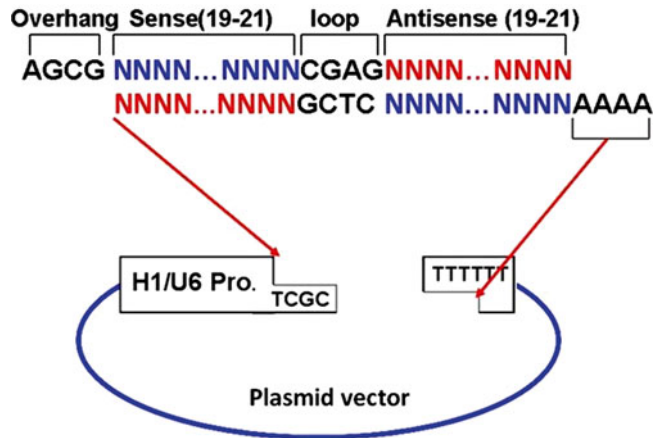

Fig. 2 Schematic diagram of shRNA expression plasmid

1.6 Challenge Studies for Estimating Protection from Pathogen

There are a number of ways in which DNA vaccine can be introduced into shrimps. Most RNAi-based therapeutic trials have been conducted on juveniles by intramuscular injection of plasmid into the abdominal segments [9, 30, 31, 71]. Dip treatment and oral administration [29, 72] are also possible, but plasmid DNA degradation and poor bioavailability from the gastro-intestinal tract are factors to be considered. The vaccinated and control animals are challenged with an appropriate titer of the pathogen and parameters such as survival, disease symptoms, histopathology, and viral load are recorded. The survival percentage is reported as the protection efficiency of the vaccine.

2 Materials

2.1 Target Sequence Selection

1. Bioinformatic tools for determining coordinates of target sequence within the target gene (Gene Runner v3.05, DNASTAR v12.2, etc.).
2. Online software for multiple sequence alignment (e.g., EBI Clustal W, MEGA v6.0).
3. Analysis of target gene using sh/lhRNA design software (E-RNAi, BLOCK-iT™ RNAi Designer, siRNA Wizard v3.1, SVM RNAi 3.6, siDESIGN Center, etc.).
4. National Center for Biotechnology Information (NCBI) BlastN online server.
5. Bioinformatic tools for DNA repeat analysis (e.g., RepeatFinder, Tandem Repeat Finder, Palindrome, Spectral Repeat Finder (SRF), RepeatMasker).

6. Online server tools for restriction site identification (e.g., NEBcutter, Webcutter 2.0, Watcut, Gene Runner).
7. Online server tools for RNA secondary structure prediction (e.g., RNAfold, Sfold, RNA123, RNASHapes).

2.2 Vector Selection

1. Lh-RNA expression: pcDNA3.1 series of vectors (Invitrogen, USA).
2. Sh-RNA expression: pSuper (Oligoengine, USA), BLOCK-iT™ shRNA Entry Vectors (Invitrogen, USA), pSilencer 2.1-U6 vector (Invitrogen, USA), pSIREN-U6 vector (Clontech, USA).
3. Target gene expression: pcDNA4/His-Max series of vectors (Invitrogen, USA).

2.3 Construction of sh/lh-RNA Expression Plasmid

1. PCR components: Template DNA (50–100 ng/μL), 10 pmol of each specific primer, 200 μM of each dNTPs, 0.75 units of *Taq* DNA polymerase and 1× *Taq* buffer containing 1.5 mM MgCl₂.
2. Selected restriction enzymes and 10× buffers.
3. Hybridization buffer for annealing complementary oligonucleotide strands: 25 mM Tris-HCl (pH 8.0) and 10 mM MgCl₂.
4. T4 DNA ligase and 10× buffer.
5. Horizontal agarose gel electrophoresis apparatus and power pack.
6. Agarose gel: For 100 mL of 1.0 % agarose gel, use 1.0 g of agarose (electrophoresis grade) with 100 mL of 0.5× TAE. Prepare 1 L of 10× TAE stock solution in ultrapure water with 48.4 g of Tris base, 3.72 g disodium EDTA, and adjust to pH 8.5 with glacial acetic acid.
7. Agarose, 6× gel loading dye, and nucleic acid stains.
8. Gel documentation system.
9. Genomic DNA, total RNA isolation and cDNA synthesis kits.
10. Gel extraction and plasmid miniprep kits.
11. *E. coli* DH5α competent cells (available commercially).
12. Water bath/incubator.
13. Luria Bertani medium: To 150 mL of double distilled water add 2 g Tryptone, 2 g NaCl, 1 g Yeast extract, 3 g Agar. Adjust the volume to 200 mL with double distilled water and sterilize by autoclaving at 121 °C and 15 psi for 15–20 min.
14. Bacteriological incubator for growing *E. coli* on plates.
15. Shaking incubator for growth of broth cultures of *E. coli*.
16. Sterile inoculation loops.

2.4 *In Vitro*

Validation

1. Sf9 insect cell line or any other convenient invertebrate cell line.
2. Appropriate growth medium components for selected cell line.
3. PBS containing 1 % v/v penicillin–streptomycin.
4. Inverted microscope.
5. CO₂ incubator for growing cells.
6. Hemocytometer for cell counting before passaging.
7. Effectene[®] Transfection Reagent (Thermo Scientific, USA) or equivalent.
8. EndoFree[®] plasmid purification kit (Qiagen, NL) to isolate endotoxin free plasmid DNA for transfection.

2.5 *Evaluation of sh/lhRNA Constructs*

In Vivo

1. Experimental shrimp (e.g., *Penaeus monodon*) of 10–12 g body weight.
2. 1000 L fiberglass tanks with seawater and aeration.
3. Kit for estimating dissolved oxygen, pH paper, thermometer, and salinometer for maintaining water quality parameters.
4. Artificial pellet feed.
5. Viral detection kits to select only healthy animals for experiments.
6. Titered viral inoculum to determine dose that results in complete mortality within 10 days.
7. Lh-RNA/sh-RNA expression construct.
8. 1 mL syringe with 20 G needle.

3 Methods

3.1 *Target Sequence Selection*

1. Retrieve the sequence information for the viral target gene in FASTA format from online databases like NCBI GenBank.
2. Perform multiple sequence alignment of the target gene obtained from different viral strains/isolates in Clustal W to identify the conserved region for silencing (*see Note 1*).
3. Remove 50–75 bp of the sequence from 5' and 3' ends of the target gene and perform BLASTn analysis to ensure that they do not share any significant homology with any known genes of the host organism (shrimp).
4. Analyze the sequence with online server tools to identify repeat sequences if any. These sequences can be removed if they are located towards the ends or else another target gene may be selected.
5. Free online software E-RNAi can be used for dsRNA molecule designing (*see Note 2*). On the E-RNAi web page select the RNAi type as 'long dsRNA' from dropbox.

6. Enable or disable the off-target evaluation option depending on whether whole genome and/or EST information is available for the experimental animal or not. No shrimp whole genome sequences are available at the time of writing this article (*see Note 3*). Copy and paste the selected region of the target gene in the box provided and click submit. On the 'De novo design: settings' page, select the number of output sequences you want to be displayed (e.g., 5).
7. The output consists of the (a) target sequence options meeting the design criteria, (b) a set of primers for each output sequence, (c) a report on the siRNA efficiency (expressed as percentage of efficient siRNAs based on predetermined criteria), and (d) specificity (calculated as the number of matching siRNAs over the number of all siRNAs in the long dsRNA of interest).
8. Select the best primer set that amplifies a conserved region (*tar*) of the gene. This region is expected to produce the largest number of efficient siRNAs and recognize all known strains/isolates of the virus.
9. Perform restriction analysis of *tar* using Gene Runner software and select restriction sites that are absent in *tar* and present in the *mcs* of selected vector for use as linkers in the primers to facilitate directional cloning.
10. *Tar* is to be cloned in forward and reverse orientations in the *mcs* of the selected vector leaving a spacer region of ~5–10 bases. Restriction enzyme (RE) sites are to be selected keeping this in mind (e.g., in pcDNA 3.1(+) using *Hind*III and *Eco*RI for forward fragment and *Eco*RV and *Xho*I for reverse will leave a spacer region of 10 bp in between).
11. To confirm whether the cassette will form a hairpin after transcription, join the forward sequence of *tar*, spacer bases and reverse sequence, and analyze it in silico for the formation of hairpin structure using RNAfold software. The reverse orientation of *tar* can be obtained in Gene Runner v 3.05.
12. Add appropriate linker sequences to the selected primer set to clone *tar* in forward and reverse orientations. This will yield two sets of primers that can be synthesized chemically. In the above example for cloning the forward fragment F and R primers will have *Hind*III and *Eco*RI recognition sequences attached as linkers while for cloning in reverse orientation the same F and R primers will have *Xho*I and *Eco*RV.

3.2 Construction of I_h-RNA Expression Plasmid

1. If the target gene belongs to a DNA virus, *tar* can be amplified from genomic DNA isolated from tissues of an infected animal using a Genomic DNA isolation kit.
2. If the target gene belongs to a RNA virus, *tar* can be amplified from cDNA prepared from an infected tissue. For this total RNA can be isolated and cDNA prepared using kits.

3. PCR amplify *tar* in both orientations. Perform PCR in 25 μ L reaction volume containing 50 ng template DNA, 10 pmol of each specific primer, 200 μ M of each dNTPs, 0.75 units of *Taq* DNA polymerase and 1 \times *Taq* buffer containing 1.5 mM MgCl₂.
4. Load the PCR product in 2 % agarose gel and resolve along with a 100 bp DNA ladder.
5. Excise the desired band from the gel and purify *tar* using gel extraction kit following manufacturer's instructions.
6. RE digest 1 μ g each of pcDNA3.1(+) vector and forward *tar*.
7. Resolve the digested vector and *tar* on 1 % and 2 % agarose gels, respectively. Excise the required bands and purify using a gel extraction kit (*see* **Note 4**).
8. Forward *tar* is ligated with the vector. Briefly, a 20 μ L ligation reaction contains vector and insert mixed in 1:3 molar ratio, 2 μ L of 10 \times reaction buffer and 1 μ L of T4 DNA ligase. The ligation reaction is incubated at 16 °C overnight.
9. For transformation, add 2 μ L of ligation mixture to the 100 μ L of *E. coli* DH5 α competent cells and incubate on ice for 20 min followed by heat shock at 43.5 °C for 50 s. Immediately replace on ice and add 1 mL LB broth. Recover the cells by shaking at 37 °C for 1 h. Plate the cells on LB-Amp-Agar plates aseptically and incubate at 37 °C overnight in an incubator.
10. Prepare master plate of the well isolated colonies. For this pick the colonies using a sterile inoculation loop and streak on a fresh LB-Amp-Agar plate and incubate overnight at 37 °C in an incubator. This will provide enough culture for screening.
11. Select 9–10 colonies and pick a minute quantity of culture with a sterile pipette tip and suspend in 10 μ L of TE buffer (pH 8.0). Perform colony PCR using 1 μ L suspended cells as template according to standard protocol. Either insert or vector specific primers may be used for amplification.
12. Load the PCR products on 2 % agarose gel and resolve along with 100 bp DNA ladder. Recombinant clones should result in the amplification of insert of the appropriate size.
13. Select 4–5 colonies of colony PCR positive clones and inoculate 2 mL of LB-Amp broth followed by incubation at 37 °C overnight in a shaking incubator.
14. Isolate plasmid DNA from the culture using a plasmid miniprep kit following manufacturer's instructions and determine the concentration by spectrophotometry (Nanodrop, biophotometer).
15. Sequencing primers provided in the cloning vector can be used for confirming the presence of the insert.
16. The reverse orientation of *tar* can be cloned into the above construct by following **steps 6–15**. This completes the synthesis of lhrRNA silencing construct.

3.3 Construction of sh-RNA Expression Plasmid

1. Perform **steps 1–6** as described in Subheading **3.1**, this time selecting ‘siRNA’ option on the E-RNAi webpage.
2. The output consists of the possible target siRNA sequences (19 bp) meeting the design criteria and an efficiency score based on predetermined criteria. The most efficient siRNA lying in the conserved region may be selected.
3. Join the forward siRNA sequence, 5–10 bp spacer region and siRNA sequence in reverse orientation in Gene Runner v 3.05. Copy the sense and antisense strands separately and paste in Notepad. Both sequences will get pasted in 5′–3′ direction. Add overhang sequences to anneal with cohesive ends created in the vector by selected REs (e.g., GTAC for *KpnI* and AGCT for *SacI* to the 3′ ends, because these enzymes generate 3′ overhangs). These final sequences can be synthesized chemically.
4. Generate a double-stranded cassette by annealing the two sense and antisense oligonucleotides. Mix approximately 40 μM of each oligomer in the buffer containing 25 mM Tris–HCl (pH 8.0) and 10 mM MgCl₂. Denature the primers by boiling for 5 min in a water bath and slowly cool down to room temperature to allow the formation of the cassette.
5. Digest 1 μg of pSUPER vector with selected REs (e.g., *SacI* and *KpnI*) and heat inactivate the enzymes by following manufacturer’s instructions.
6. Prepare the construct by following **steps 7–15** of Subheading **3.2**. This completes the synthesis of shRNA silencing construct.

3.4 Expression Construct of Target Gene

1. Design primers to amplify full length target gene for in-frame cloning in any selected pcDNA4 HisMax series of vectors. Add appropriate linkers to the primers for directional cloning. PCR amplify the target gene proceed as described in **steps 4–15** in Subheading **3.2**. This will synthesize the target gene expression construct.

3.5 In Vitro Estimation of Silencing Efficiency

1. The day before transfection, freshly passage the cells with recommended split ratio, so as to get the desired confluency (60–80 %) after 24 h, which is ideal for optimal transfection. The confluency can be confirmed under a microscope and the cell count can be obtained by using a hemocytometer.
2. Isolate the lh/shRNA silencing constructs and target gene expression plasmid using EndoFree® plasmid purification kit (Qiagen, NL) in order to avoid cytotoxicity due to endotoxins that co-purify with plasmid DNA.
3. Transfect the cultured cells with lh/shRNA silencing construct along with the target gene expression construct in equimolar ratio following manufacturer’s instructions and culture the cells for 24–48 h. As a positive control, transfect cells with

target gene expression construct along with the empty vector. For negative control, transfect cells with only the empty vector.

4. Harvest the cells post transfection and wash twice with PBS containing 1 % v/v penicillin–streptomycin.
5. Isolate total RNA from the transfected cells and prepare cDNA using oligo-dT primers.
6. Target gene silencing can be determined by quantifying the transcript by real time PCR using primers designed in a region other than *tar*.
7. The silencing effect may also be determined at protein level by western blotting using anti-His tag antibodies.
8. The sh/lh construct that results in higher silencing efficiency can be tested in vivo (*see Note 5*).

3.6 Evaluation of sh/ lhRNA Constructs In Vivo

1. Maintain experimental shrimp in 1000 L fiberglass tanks with aeration at 27–30 °C with appropriate salinity and artificial pellet feed thrice a day.
2. Monitor the water quality parameters such as temperature, pH, salinity, and dissolved oxygen at weekly intervals.
3. Prior to use, screen the experimental animals for the presence of pathogens under study using viral detection kits to ensure that only healthy individuals are used for the experiment.
4. Inject the treatment group intramuscularly with lh/sh-RNA expression plasmid at the rate of 1 µg/g body weight in a 100 µL volume using a disposable 1 mL syringe.
5. Inject negative and positive control groups similarly with empty vector.
6. Challenge the treatment and positive control groups with viral inoculum that results in 100 % mortality in about 10 days. Negative control group is injected with PBS buffer.
7. Monitor the shrimp daily and document the mortality pattern in each group until 90 % of the animals in a particular batch die. Freeze the dead shrimp in –80 °C for further use.
8. Ascertain the cause of death in the experimental animals by histopathology or molecular diagnostic tools like PCR or ELISA (to confirm death is due to infection and not other causes).
9. The viral copy number may be estimated in the vaccinated and control animals by real-time RT-PCR to calculate the silencing efficiency.
10. The vaccine efficiency is reported in terms of percent survival of vaccinated animals over controls and percent reduction in viral copy number.

4 Notes

1. In order to identify mutation prone regions within the viral gene to be silenced all the sequences should be subjected to multiple sequence alignment. These regions should be excluded while identifying the target sequence.
2. Almost all commercial suppliers of siRNA consumables provide online design service for free.
3. The E-RNAi software also offers the off-target evaluation with genomic/transcript database of popular model organisms. Since such information is very meager for shrimp the best alternative available is to go for BLAST analysis.
4. Restriction enzyme digestion is not 100 % efficient and often results in contamination with uncut DNA. This is particularly important in case of plasmid DNA as uncut plasmid runs close to the cut plasmid if the plasmid size is more than 5 kb. Therefore, it is recommended to completely resolve the RE digested plasmid DNA on 1 % agarose to avoid cross contamination with uncut plasmid.
5. In spite of all precautions, some sequences may lead to unexpected toxicity in vivo and so a pragmatic approach would be to screen 4–5 sequences for each gene before choosing the most effective therapeutic construct for in vivo trials.

Acknowledgements

This chapter described work funded by Central Institute of Fisheries Education, Mumbai (Indian Council of Agricultural Research).

References

1. Tang D, Devit M, Johnston SA (1992) Genetic immunization is a simple method for eliciting an immune response. *Nature* 356:152–154
2. Alarcon JB, Waine GW, McManus DP (1999) DNA vaccines: technology and application as anti-parasite and anti-microbial agents. *Adv Parasitol* 42:343–410
3. Robinson HL, Pertmer TM (2000) DNA vaccines for viral infections: basic studies and applications. *Adv Virus Res* 55:1–74
4. Evensen Ø, Leong JA (2013) DNA vaccines against viral diseases of farmed fish. *Fish Shellfish Immunol* 35:1751–1758
5. Saloni K, Simard N, Harland R, Ulmer JB (2007) The road to licensure of a DNA vaccine. *Curr Opin Investig Drugs* 8:635–641
6. Soderhall K (1999) Special Issue: invertebrate immunity. *Dev Comp Immunol* 23:4–5
7. Witteveldt J, Cifuentes CC, Vlask JM, van Hulten MC (2004) Protection of *Penaeus monodon* against white spot syndrome virus by oral vaccination. *J Virol* 78:2057–2061
8. Witteveldt J, Vlask JM, van Hulten MCW (2004) Protection of *Penaeus monodon* against white spot syndrome virus using a WSSV subunit vaccine. *Fish Shellfish Immunol* 16:571–579

9. Rout N, Kumar S, Jaganmohan S, Murugan V (2007) DNA vaccines encoding viral envelope proteins confer protective immunity against WSSV in black tiger shrimp. *Vaccine* 25: 2778–2786
10. Fire A, Xu S, Montgomery MK, Kostas SA, Driver SE, Mello CC (1998) Potent and specific genetic interference by double-stranded RNA in *Caenorhabditis elegans*. *Nature* 391: 806–811
11. Hammond SM, Bernstein E, Beach D, Hannon GJ (2000) An RNA-directed nuclease mediates post-transcriptional gene silencing in *Drosophila* cells. *Nature* 404:293–296
12. Martinez J, Patkaniowska A, Urlaub H, Lührmann R, Tuschl T (2002) Single-stranded antisense siRNAs guide target RNA cleavage in RNAi. *Cell* 110:563–574
13. Denli AM, Hannon GJ (2003) RNAi: an ever-growing puzzle. *Trends Biochem Sci* 28: 196–201
14. Janowski BA, Huffman KE, Schwartz JC, Ram R, Nordsell R et al (2006) Involvement of AGO1 and AGO2 in mammalian transcriptional silencing. *Nat Struct Mol Biol* 13: 787–792
15. Wang Y, Juranek S, Li H, Sheng G, Tuschl T, Patel DJ (2008) Structure of an Argonaute silencing complex with a seed-containing guide DNA and target RNA duplex. *Nature* 456: 921–926
16. Rehwinkel J, Behm-Ansmant I, Gatfield D, Izaurralde E (2005) A crucial role for GW182 and the DCP1:DCP2 decapping complex in miRNA-mediated gene silencing. *RNA* 11:1640–1647
17. Kulkarni M, Ozgur S, Stoecklin G (2010) On track with P-bodies. *Biochem Soc Trans* 38:242–251
18. Li F, Ding SW (2006) Virus counter defense: diverse strategies for evading the RNA-silencing immunity. *Annu Rev Microbiol* 60: 503–531
19. Cogoni C, Macino G (2000) Post-transcriptional gene silencing across kingdoms. *Curr Opin Genet Dev* 10:638–643
20. Vaucheret H, Beclin C, Fagard M (2001) Post-transcriptional gene silencing in plants. *J Cell Sci* 114:3083–3091
21. Wightman B, Ha I, Ruvkun G (1993) Posttranscriptional regulation of the heterochronic gene *lin-14* by *lin-4* mediates temporal pattern formation in *C. elegans*. *Cell* 75: 855–862
22. Lee RC, Feinbaum RL, Ambros V (1993) The *C. elegans* heterochronic gene *lin-4* encodes small RNAs with antisense complementarity to *lin-14*. *Cell* 75:843–854
23. Lightner DV, Redman RM (1998) Shrimp diseases and current diagnostic methods. *Aquaculture* 164:201–220
24. Escobedo-Bonilla CM (2011) Application of RNA Interference (RNAi) against Viral Infections in Shrimp: a Review. *J Antivir Antiretrovir* S9:1–12
25. Robalino J, Bartlett T, Shepard E, Prior S, Jaramillo G, Scura E, Chapman RW, Gross PS, Browdy CL, Warr GW (2005) Double-stranded RNA induces sequence-specific antiviral silencing in addition to non-specific immunity in marine shrimp: convergence of RNA interference and innate immunity in the invertebrate antiviral response? *J Virol* 79: 13561–13571
26. Westenberg M, Heinhuis B, Zuidema D, Vlaskovits JM (2005) siRNA injection induces sequence-independent protection in *Penaeus monodon* against white spot syndrome virus. *Virus Res* 114:133–139
27. Yodmuang S, Tirasophon W, Roshorm Y, Chinnirunvong W, Panyim S (2006) YHV protease dsRNA inhibits YHV replication in *Penaeus monodon* and prevents mortality. *Biochem Biophys Res Comm* 341:351–356
28. Xu J, Han F, Zhang X (2007) Silencing shrimp White Spot Syndrome Virus (WSSV) genes by siRNA. *Antiviral Res* 73:126–131
29. Sarathi M, Simon MC, Ahmed VP, Kumar SR, Sahul-Hameed AS (2008) Silencing VP28 gene of white spot syndrome virus of shrimp by bacterially expressed dsRNA. *Mar Biotechnol* 10:198–206
30. Krishnan P, Babu PG, Saravanan S, Rajendran KV, Chaudhari A (2009) DNA constructs expressing long-hairpin RNA (lhRNA) protect *Penaeus monodon* against White Spot Syndrome Virus. *Vaccine* 27:3849–3855
31. Das R, Karthireddy S, Gireesh-Babu P, Reddy AK, Krishna G, Chaudhari A (2011) Protection of *Penaeus monodon* on WSSV challenge by DNA construct expressing LH-RNA against ICP11 gene singly and in combination. *Ind J Virol* 21:95–102
32. Su J, Oanh DT, Lyons RE, Leeton L, van Hulten MC, Tan SH, Song L, Rajendran KV, Walker PJ (2008) A key gene of the RNA interference pathway in the black tiger shrimp, *Penaeus monodon*: identification and functional characterisation of Dicer-1. *Fish Shellfish Immunol* 24:223–233
33. Li X, Yang L, Jiang S, Fu M, Huang J, Jiang S (2013) Identification and expression analysis of Dicer2 in black tiger shrimp (*Penaeus monodon*)

- responses to immune challenges. *Fish Shellfish Immunol* 35:1–8
34. Yao X, Wang L, Song L, Zhang H, Dong C, Zhang Y, Qiu L, Shi Y, Zhao J, Bi Y (2010) A Dicer-1 gene from white shrimp *Litopenaeus vannamei*: expression pattern in the processes of immune response and larval development. *Fish Shellfish Immunol* 29: 565–570
 35. Chen YH, Jia XT, Zhao L, Li CZ, Zhang S, Chen YG, Weng SP, He JG (2011) Identification and functional characterization of Dicer2 and five single VWC domain proteins of *Litopenaeus vannamei*. *Dev Comp Immunol* 35:661–671
 36. Li S, Zhang X, Sun Z, Li F, Xiang J (2013) Transcriptome analysis on Chinese shrimp *Fenneropenaeus chinensis* during WSSV acute infection. *PLoS One* 8(3):e58627
 37. Huang TZ, Zhang XB (2012) Characterization of two members of the dicer family in shrimp *Marsupenaeus japonicus*. Unpublished (Source: GenBank Accession number: JQ349041).
 38. Nishi J, Mekata T, Okugawa S, Yoshimine M, Sakai M, Itami T (2014) Identification of dicer-2 from *Marsupenaeus*. Unpublished (source: GenBank accession number: AB618794).
 39. Nielsen C, Berdal KG, Bakke-McKellep AM, Holst-Jensen A (2005) Dietary DNA in blood and organs of Atlantic salmon (*Salmo salar* L.). *Eur Food Res Technol* 221:1–8
 40. Nielsen C, Holst-Jensen A, Løvseth A, Berdal KG (2006) Persistence and distribution of intravenously injected DNA in blood and organs of Atlantic salmon (*Salmo salar* L.). *Eur Food Res Technol* 222:258–265
 41. Tonheim TC, Leirvik J, Løvoll M, Myhr AI, Bøgwald J, Dalmo RA (2007) Detection of supercoiled plasmid DNA and luciferase expression in Atlantic salmon (*Salmo salar* L.) 535 days after injection. *Fish Shellfish Immunol* 23:867–876
 42. Tonheim TC, Dalmo RA, Bøgwald J, Seternes T (2008) Specific uptake of plasmid DNA without reporter gene expression in Atlantic salmon (*Salmo salar* L.) kidney after intramuscular administration. *Fish Shellfish Immunol* 24:90–101
 43. Seternes T, Tonheim TC, Løvoll M, Bøgwald J, Dalmo RA (2007) Specific endocytosis and degradation of naked DNA in the endocardial cells of cod (*Gadus morhua* L.). *J Exp Biol* 210:2091–2103
 44. Boudinot P, Blanco M, de Kinkelin P, Benmansour A (1998) Combined DNA immunization with the glycoprotein gene of viral hemorrhagic septicemia virus and infectious hematopoietic necrosis virus induces double-specific protective immunity and nonspecific response in rainbow trout. *Virology* 249: 297–306
 45. Lee JY, Hirono II, Aoki T (2000) Stable expression of a foreign gene, delivered by gene gun, in the muscle of rainbow trout *Oncorhynchus mykiss*. *Mar Biotechnol* 2:254–258
 46. Romøren K, Thu BJ, Evensen Ø (2004) Expression of luciferase in selected organs following delivery of naked and formulated DNA to rainbow trout (*Oncorhynchus mykiss*) by different routes of administration. *Fish Shellfish Immunol* 16:251–264
 47. Tonheim TC, Bøgwald J, Dalmo RA (2008) What happens to the DNA vaccine in fish? A review of current knowledge. *Fish Shellfish Immunol* 25:1–18
 48. Kurath G, Garver KA, Corbeil S, Elliott DG, Anderson ED, LaPatra SE (2006) Protective immunity and lack of histopathological damage two years after DNA vaccination against infectious hematopoietic necrosis virus in trout. *Vaccine* 24:345–354
 49. Sano M, Li H, Nakanishi M, Rossi JJ (2008) Expression of long anti-HIV-1 hairpin RNAs for the generation of multiple siRNAs: advantages and limitations. *Mol Ther* 16:170–177
 50. Saayman S, Arbuthnot P, Weinberg MC (2010) Deriving four functional anti-HIV siRNAs from a single Pol III-generated transcript comprising two adjacent long hairpin RNA precursors. *Methods Mol Biol* 629:159–174
 51. Wilson RC, Doudna JA (2013) Molecular mechanisms of RNA interference. *Annu Rev Biophys* 42:217–239
 52. Konstantinova P, de Vries W, Haasnoot J, ter Brake O, de Haan P, Berkhout B (2006) Inhibition of human immunodeficiency virus type 1 by RNA interference using long-hairpin RNA. *Gene Ther* 19:1403–1413
 53. Barber GN (2001) Host defense, viruses and apoptosis. *Cell Death Differ* 8:113–126
 54. Tavernarakis N, Wang SL, Dorovkov M, Ryazanov A, Driscoll M (2000) Heritable and inducible genetic interference by double-stranded RNA encoded by transgenes. *Nat Genet* 24:180–183
 55. Svoboda P, Di Cara A (2006) Hairpin RNA: a secondary structure of primary importance. *Cell Mol Life Sci* 63:901–908
 56. Rosa RD, Barracco MA (2008) Shrimp interferon is rather a portion of the mitochondrial F0-ATP synthase than a true alpha-interferon. *Mol Immunol* 45:3490–3493
 57. Krishnan P, Gireesh-Babu P, Rajendran KV, Chaudhari A (2009) RNA interference-based

- therapeutics for shrimp viral diseases. *Dis Aquat Org* 86:263–272
58. Grimm D, Kay MA (2007) Combinatorial RNAi: a winning strategy for the race against evolving targets? *Mol Ther* 15:878–888
 59. Leonard JN, Schaffer DV (2006) Antiviral therapy: emerging approaches for hitting a moving target. *Gene Ther* 13:532–540
 60. Drake JW, Charlesworth B, Charlesworth D, Crow JF (1998) Rates of spontaneous mutation. *Genetics* 148:1667–1686
 61. Peek AS, Behlke MA (2007) Design of active small interfering RNAs. *Curr Opin Mol Ther* 9:110–118
 62. Elbashir SM, Harborth J, Weber K, Tuschl T (2002) Analysis of gene function in somatic mammalian cells using small interfering RNAs. *Methods* 26:199–213
 63. Hsieh AC, Bo R, Manola J, Vazquez F, Bare O, Khvorova A, Scaringe S, Sellers WR (2004) A library of siRNA duplexes targeting the phosphoinositide 3-kinase pathway: determinants of gene silencing for use in cell-based screens. *Nucleic Acids Res* 32:893–901
 64. Arizman Z, Horn T et al (2005) E-RNAi: a web application to design optimized RNAi constructs. *Nucleic Acids Res* 33(Web Server Issue):W582–W588
 65. Reynolds A, Leake D, Boese Q, Scaringe S, Marshall WS, Khvorova A (2004) Rational siRNA design for RNA interference. *Nat Biotechnol* 22:326–330
 66. Arenal A, Pimentel R, Guimaraes M, Rodriguez A, Martinez R, Abad Z (2000) Gene transfer in shrimp (*Litopenaeus schmitti*) by electroporation of single cell embryos and injection of naked DNA into adult muscle. *Biotechnol Appl* 17: 247–250
 67. Vandermeulen G, Marie C, Scherman D, Pr at V (2011) New generation of plasmid backbones devoid of antibiotic resistance marker for gene therapy trials. *Mol Ther* 11:1942–1949
 68. Sodoyer R, Courtois V, Peubez I, Mignon C (2012) Antibiotic-free selection for bio-production: moving towards a new “Gold Standard”. In: Pana M (ed) Antibiotic resistant bacteria - a continuous challenge in the new millennium. InTech, Rijeka, Croatia. doi:[10.5772/28510](https://doi.org/10.5772/28510). ISBN ISBN: 978-953-51-0472-8
 69. FAO (1996) Points to consider on plasmid DNA vaccines for preventive infectious disease indications. *Fed Regist* 61(250): 68269–68270
 70. Han Q, Li P, Lu X, Guo Z, Guo H (2013) Improved primary cell culture and subculture of lymphoid organs of the greasy back shrimp *Metapenaeus ensis*. *Aquaculture* 410:101–113
 71. Kumar SR, Ahamed VPI, Sarathi M, Basha AN, Hameed ASS (2008) Immunological responses of *Penaeus monodon* to DNA vaccine and its efficacy to protect shrimp against white spot syndrome virus (WSSV). *Fish Shellfish Immunol* 24:467–478
 72. Musthaq SS, Kwang J (2011) Oral vaccination of baculovirus-expressed VP28 displays enhanced protection against white spot syndrome virus in *Penaeus monodon*. *PLoS One* 6:26428

Part IV

Vaccines Against Ticks

Developing Anti-tick Vaccines

Alina Rodríguez-Mallon

1 Introduction

Ticks cause direct and indirect effects in the animals that they parasitize. Direct effects are characterized by anemia, toxic action of bites, loss of appetite, and growth delay, in addition to a diminution in the quality of leathers. The indirect effects are related to the transmission of a great variety of infectious agents by ticks [1], which leads to diseases, diminution of productive yield, or deaths. The annual productivity losses attributed to cattle ticks in the world are around 7 billion USD per year [2].

Chemical methods are commonly employed for tick control [3]. This approach produces resistant ticks, food contamination, and environmental pollution. The use of biological methods is another strategy to control ticks. These are based on the use of hormones and other growth regulators, as well as the use of biological agents as predators, bacteria, nematodes, and fungi. In addition to these two methods, there are also physical methods to control ticks. It has been proved that the development of ticks during the non-parasitic life stage depends largely on the external conditions of humidity and temperature. Meadows with tall vegetation and shrubs provide an ideal habitat for tick development. Heavy grazing reduces vegetation cover and may limit the survival of eggs and larvae [4]. Another physical control method against ticks that has been used is the burning of grasslands, which affects ticks directly by exposure to high temperatures and indirectly by the destruction of the vegetation cover that protects ticks [5]. However, burning constitutes a major risk for the generation of wildfires that have terrible consequences for the environment by destroying wildlife habitat, killing animals that cannot escape, altering biodiversity, with the consequent alterations in the food chain, loss of natural seed banks, loss of organic matter and various

elements, producing soil erosion, altering water infiltration into the soil, and promoting contamination and sedimentation of watercourses and reservoirs. All these factors endanger human lives, the scenic and recreational value of the natural environment and eventually affect agriculture productivity due to soil impoverishment [6].

Vaccination is considered an alternative to control ectoparasite infestations. The immunological control of ticks is exempt from environmental problems as opposed to others and has prospects of a durable protection [7]. The background of this method is present in nature where there are animals that are genetically resistant to ticks. It has been shown that the resistance is inherited and is increased by selection of animals. For example, European *Bos taurus* cattle breeds (Swiss, Charolais, Holstein, and Simmental) are more susceptible compared to *Bos indicus* breeds (Brahman, Nellore, and Indubrasil Guzerat) that can reach up to 99 % resistance. In other cases, some species of animals may have acquired resistance, after repeated natural infestations with the parasite that is reflected in the decrease of the weight of ticks feeding on them, and reduction in the number of ectoparasites per animal [8, 9]. Researchers have explored immunological control as an alternative to the limitations of conventional methods since the 1980s [10, 11]. The development of vaccines against ticks has been slow because the validation of new antigens is a long and complicated process that requires laborious, often expensive work. After the identification and evaluation of candidate antigens, defining the basic immunological mechanisms induced by these antigens and the development of suitable methods for their production, are also required. Also needed are optimization studies on the immune response of the host, economic feasibility testing of the vaccine, as well as field trials, product registration and the evaluation of the product once it has been released for commercial use [12]. Further, the effect shown by all antigens assayed during the study is not like that shown by classical vaccines or a knockdown effect like the chemical acaricides.

In general, anti-tick vaccines have two different types of antigenic targets. The first is the use of so-called “exposed” antigens that are proteins or peptides secreted in the tick’s saliva during the clamping and feeding of these ectoparasites on the host [13]. In contrast, so-called “concealed” antigens are those that are not visible to the host immune mechanisms [14]. The effects of the immune responses to tick antigens, either concealed or exposed, are similar and are expressed as increased mortality of ticks and eggs, weight loss of engorged ticks and eggs, prolonged feeding period, and molting inhibition [15]. However, the action mode of vaccines based on concealed antigens differs markedly from those vaccines with exposed antigens. The lack of contact between concealed antigens and the host immune system precludes the

parasites from developing strategies to escape the action of a response against them; this makes them especially attractive for the design of vaccines against ectoparasites. However, concealed antigens do not induce an immune response in the host during tick feeding, they are immunogenic only when they are delivered artificially to the host as a tissue extract of ticks or as biotechnologically produced proteins. Thus to induce the antibody response repeated immunizations are essential.

The pioneer recombinant antigen for vaccination against ticks is Bm86 [14, 16]. Bm86 is a glycoprotein present in the intestinal epithelium of *Rhipicephalus (Boophilus) microplus* ticks [17, 18]. Its expression is restricted to a few places on the digestive cell membrane, on the microvilli exposed to the intestinal lumen [19, 20]. Bm86 is therefore a “concealed” antigen, whose function is unknown, although it has been speculated that it is involved in the endocytosis of blood ingested by ticks [18, 21]. Despite the discovery of Bm86 in 1986 and its commercial introduction in 1994, there is still no availability of more effective alternative vaccines against ticks and ectoparasites in general. In vaccinated cattle, the Cuban vaccine based on Bm86 (Gavac) controls artificial infestations of different strains of *R. (Boophilus) microplus* with an effectiveness between 51 and 91 % [22]. The effect of this immunogen, unlike the effect of chemical acaricides, does not cause the immediate death of the parasites, but produce long term damage to the tick population by reducing its biotic potential as explained above. In field studies, Gavac is effective only when its application is included within an integrated control program that harmoniously combines different methods. None of the methods discussed above, applied in isolation, is fully effective in controlling the ixodides; an integrated management protocol that includes baths with effective acaricides based on infestation levels, rotation of grassland, and vaccination of the entire herd allows the reduction of tick infestations and the diminution in use of chemicals [22–25].

Besides bowel antigens, the “concealed” molecules derived from other tick tissues can be used for vaccine development. Digestion of the blood by ticks occurs within intestinal cells and it is known that some intact immunoglobulin molecules pass from midgut to the hemolymph, which allows them to interact with their corresponding antigens on internal organs within the tick body and cause damage [26–28]. When considering any candidate for an anti-tick vaccine, it is useful to consider the ideal characteristics of this type of immunogen. First, the selected antigen should be broad spectrum, that is, active against many species of ticks and ideally against multiple stages of the life cycle of ticks. Another important feature is that the antigen should be able to induce long-lasting immunity to minimize the need for repeated immunizations and thereby reduce costs. Preferably the response against the antigen must affect the attachment of ticks. If possible, the

vaccine must have the potential to reduce the vector ability of ticks and consequently reduce the incidence of tick-borne diseases. Finally, the vaccine antigens should be relatively easy and inexpensive to produce [13]. There is currently a strong trend towards the use of reverse vaccinology to identify and test novel antigens in vaccination trials [29]. However, trials of new antigens require the establishment of an experimental model that reduces the variability of the factors related to ticks while taking into account the complex tick-host relationship.

Several groups worldwide have conducted vaccination trials with a number of new antigens. The results of some of these trials have been disappointing [30, 31] and other studies have shown attractive candidates for further evaluations [32–36]. However, having an antigen with a good performance in vaccine trials is not enough to ensure the commercial success of a new generation of vaccines against ticks. Scientific proof of concept and meeting the requirements of safety and efficacy demonstrated under field conditions are only part of the equation for taking a new antigen as a product to market. Industrial development of a vaccine against ticks also requires investments by companies dedicated to animal health [37]. Thus the research to generate new anti-tick vaccines also goes through the challenge of achieving the interest of the biotechnology industry to enable the production and marketing of innovative, potentially beneficial technologies.

1.1 Establishment of an Experimental Model to Test New Antigens against Ticks

Ticks are external parasites that have to overcome the defense mechanisms of the vertebrates they parasitize to obtain blood for their survival. As a result, ticks have developed complex interactions with the parasitized host through evolution [2, 38]. In view of this, the selection of a suitable experimental model that is able to reproduce the complexity of the parasite–host relationship constitutes a major factor in the successful identification and development of new candidate vaccines against ticks. To the extent that the model mimics the interaction that occurs in nature the probability of finding the harmful effects of the immunogen on ticks increases. At the same time, a major obstacle for experiments with new antigens against ticks for laboratories and industry is the cost of testing in the target species. Thus, the model selected for the investigation must establish a balance between the factors mentioned above: reproduction of the complexity of the parasite–host relationship and low costs. In addition, assays for development of new antigens require large numbers of live, laboratory-raised ticks to provide relevant biological data about the effectiveness of these antigens. The selection of the tick species as model should take into consideration the application for the future vaccine and the ability of the selected species to parasitize a wide range of mammalian hosts, in addition to its natural host. The best hosts among the species which our tick model is able to parasitize must be selected for the colony maintenance and for the immunization and challenge trials. General laboratory setup, tick feeding protocols

and environmental requirements necessary for the establishment and maintenance of a colony of ticks under controlled laboratory conditions are described here, based on long-term colony maintenance and production of a reliable supply of ticks, under standardized conditions, suitable for challenge studies.

1.2 Trials to Test New Antigens against Ticks

As mentioned above, after identification of a candidate antigen for production of an anti-tick vaccine by any of the methods available to us (reverse vaccinology, screening of different kind of libraries, in silico studies, review of reported important molecules in the tick survival, and others), it is necessary to produce enough antigen to obtain the scientific proof of concept. In this connection, biotechnology methods can be used to express the antigen in bacteria, yeast, plants, insect cells or mammalian cells depending of the immunogen's nature or the chemical synthesis can be also used if suitable.

After the experimental model to test new antigens is established, the selected mammalian host must be immunized with the antigen. In order to guarantee a good immune response, it is important to find ways in which the antigens *are* well presented to the host immune system. Given the nature of the antigenic protein, carrier proteins and adjuvants are part of the solution to enhance the immunogenicity of the vaccines; however, the antigen geometry may be the key to a successful vaccine. The formulation, routes of administration, and the immunization schedule can also play an essential role [39]. The inclusion of mineral oil in the vaccine preparation is one way to achieve slow release of antigen [40]. The antigen selection, the nature of the adjuvant used, the formulation, and the mode of administration employed that effects the immune response, the quantity and quality of the antibodies generated that has an effect against the ectoparasites are stated in this chapter. A method to perform a challenge trial to test the vaccine efficacy is also presented. The data that should be recorded, how to analyze the data, and the methodology to calculate the vaccine efficacy are also discussed in this chapter.

2 Materials

2.1 Establishment of an Experimental Model to Assay New Antigens against Ticks

2.1.1 Taxonomic Classification and Characterization of Tick Specimens for the Establishment and Maintenance of a Tick Colony

1. Stereoscope and optical microscope.
2. Digital camera coupled to the stereoscopes and microscopes.
3. Analytical balance.
4. Reverse Transcription System (Promega, USA).
5. System GoTaq® Green Master Mix (Promega, USA).
6. Minicycler™ thermal cycler to develop PCR.
7. QIAquick Gel Extraction kit (250) (Qiagen, Germany).
8. pGEM-T Easy Vector (Promega, USA).
9. Sequencing services.

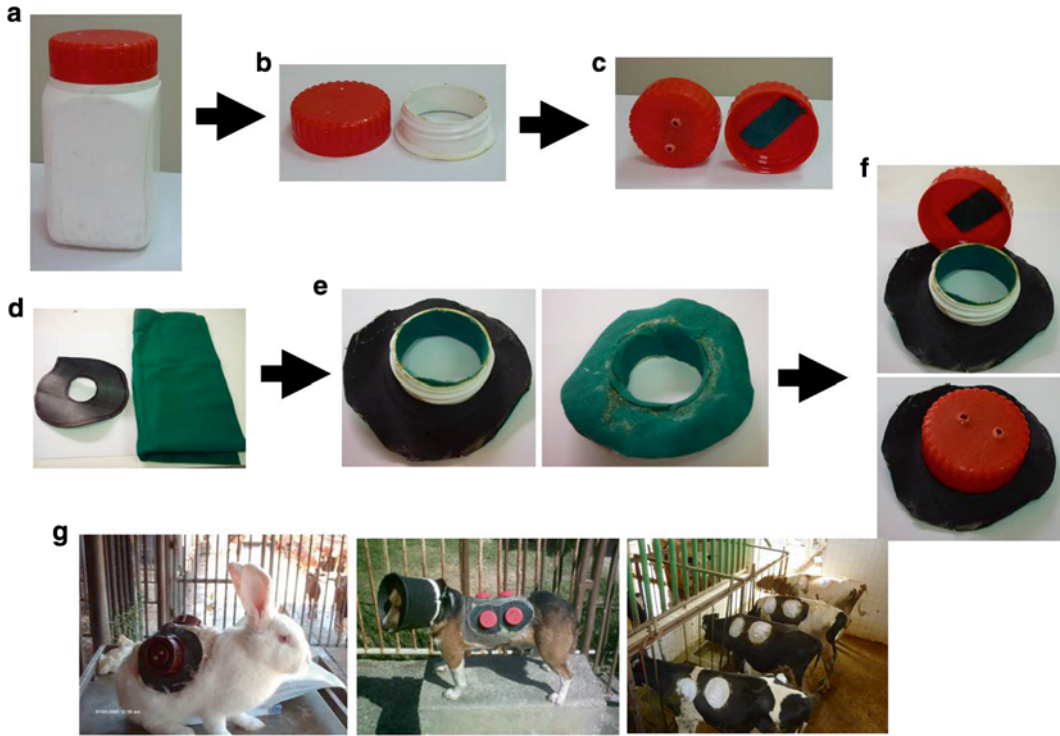

Fig. 1 Craft feeding chambers used to feed all parasitic stages of ticks in the colony. (a) Recycled culture media bottles (Oxoid); (b) Screw-tops of recycled culture media bottles; (c) Holes in the caps to promote oxygenation; (d) Cloth and rubber circles used to construct the chambers; (e, f) Chamber appearance after assembly of all components using bonding cement; (g) Feeding chambers glued to the shaved host skin with bonding cement

10. BLASTn [41] for sequence identity analysis.
11. ClustalW program [42] for sequence alignments.
12. MEGA version [43] for phylogenetic and molecular evolutionary analyses.

2.1.2 Parasitic Tick Stages

1. Craft feeding chambers (Screw-tops of recycled culture media bottles, circles of cloth and rubber, 15 cm in diameter) (Fig. 1).
2. Bonding cement (Supergen, Spain).
3. Clippers.
4. 70 % ethanol.
5. Elizabethan collars.
6. Animal hosts and animal house.

2.1.3 Non-parasitic Tick Stages

1. Glass flasks with mesh tops.
2. Syringes.
3. Disposable petri dish.
4. Double sided tape.

5. Incubator with control of temperature, humidity, and photo-period or incubator with control of temperature and desiccators with a solution of 5 % KCl inside.
6. Stereoscope (Kyowa Optical, Model SDZ-8).
7. Analytical balance (Kern ABT).
8. PBS 1× (135 mM NaCl, 8 mM Na₂HPO₄, 3 mM KCl, 1.5 mM KH₂PO₄, pH 7.2).
9. Filter paper (Whatman 3 MM).

2.2 Immunization and Challenge Experiment

1. Animal hosts, cages, and animal house.
2. Specific diet for animal hosts.
3. Purified antigen and all components in the formulation.
4. Polytron (UltraTurrax T25, IKA).
5. Syringes.
6. Microfuge.
7. Micropipettes.
8. Polysorp ELISA plates (Nunc).
9. PBS 1× (NaCl 8 g/L, Na₂HPO₄ 1.15 g/L, KCL 0.2 g/L, KH₂PO₄ 0.2 g/L, pH 7–7.2).
10. Tween 20.
11. Nonfat milk.
12. Anti-host IgG conjugated to horseradish peroxidase.
13. Substrate solution (*o*-phenylenediamine 0.4 mg/mL in 0.1 M citric acid and 0.2 M Na₂HPO₄, pH 5.0 and 0.015 % hydrogen peroxide).
14. H₂SO₄.
15. Multiscan to read ELISA plates.
16. All materials described in the Subheadings [2.1.2](#) and [2.1.3](#).

3 Methods

3.1 Establishment of an Experimental Model to Assay New Antigens against Ticks

1. Select the appropriate experimental model: tick and host species (*see Note 1*).
2. Isolation of ticks from the field (*see Note 2*).
3. Perform taxonomic classification of tick specimens: morphologic and molecular characterization (*see Note 3*).
4. Characterize the tick life cycle under the established laboratory conditions (*see Note 4*).

3.2 Immunization and Challenge Experiment

1. Select the antigen (*see Note 5*).
2. Produce the antigen in a desired method (*see Note 6*).

3. Prepare the immunogens (*see Note 7*).
4. Select the mammalian host for the assay (*see Note 8*).
5. Establish the immunization schedule (*see Note 9*).
6. Characterize the antibody response (*see Note 10*).
7. Challenge with ticks (*see Note 11*).
8. Record relevant data and perform data analysis (*see Note 12*).
9. Calculate overall efficacy (*see Note 13*).

4 Notes

1. There are about 907 known species of ticks, which are grouped in three families: Argasidae (“soft ticks”), Ixodidae (“hard ticks”), and Nuttalliellidae [44]. The Ixodidae family is in turn divided into Prostriata which is represented by a single genus *Ixodes* and Metastricata which includes the remaining 13 genera. There are 650 species of ticks in this family who constitute approximately 80 % of ticks described [45]. If the tick species selected is a three-host tick, it complicates the system, but in general these ticks parasitize a wide range of mammalian hosts in addition to their natural host. If the tick species selected is a one-host tick, the model is easier but in general these ticks parasitize species as sheep, cattle, or horses which have a high economic cost. It is also important to consider the final destination of the anti-tick vaccine; the selected tick species should be as close as possible to the species of interest. The mammalian hosts for the colony maintenance and for the immunization and challenge trials must be selected among the species which our tick model is able to parasitize.
2. The selected tick species must be isolated near the habitat of its natural host.
3. Morphological and morphometric characterizations of collected specimens must be performed by observation under a stereoscope or an optical microscope [46]. The specimens used for identification are placed at $-20\text{ }^{\circ}\text{C}$ for 15 min before being photographed to prevent movement. Currently, traditional morphological characterization of the genera and species of ticks is accompanied by molecular methods, which are important tools in the classification of mites and ticks [47, 48]. DNA fragments corresponding to the 18S rRNA, 16S and 12S ribosomal and mitochondrial genes are frequently used for classification. Total RNA or genomic DNA from ticks are extracted and in the case of RNA, complementary DNA is obtained with random primers using a Reverse Transcription System according to the manufacturer’s instructions. Specific primers must be designed for

conventional PCR. PCR conditions include an initial denaturation step at 95 °C followed by 35 cycles of denaturation, annealing and extension. The temperature of annealing must be at least four grades under the melting temperature of the designed primers. The amplified DNA fragments are also sequenced. Sequence identity analyses, alignment of these sequences and phylogenetic and molecular evolutionary analyses should be performed. For each gene, homologous sequences from other tick genera must be used as outgroups in the phylogenetic analysis.

4. Knowledge of the life cycle of ticks under controlled laboratory conditions and the survival under starvation are very important in the management of a tick colony. The temperature and humidity conditions and the host type have been shown to be key factors in the developmental cycle of ticks [49–52]. The conditions for non-parasitic and parasitic tick stages must be established. Parasitic stages of ticks are fed inside craft feeding chambers glued to shaved flanks of mammalian host with bonding cement. The feeding chambers are constructed using circles of cloth and rubber, 15 cm in diameter, and screw-tops of recycled culture media bottles. Holes are opened in the caps to promote oxygenation (Fig. 1). The chambers are glued to the host's skin after shaving with clippers. The shaved area is washed with 70 % ethanol to remove the cut hairs and sebaceous secretions that might interfere with the bonding. Twenty-four hours after placing the chambers, ticks to be fed are placed into them. From this moment, hosts are kept under daily observation to harvest the fed ticks. Elizabethan collars are used during infestation periods to prevent chamber removal. Individual boxes or cages are used during infestation periods. Animals must be handled according to international guidelines for experimentation with animals [53]. The non-parasitic stages are kept in glass flasks with mesh tops, in an incubator with defined photoperiod, temperature and relative humidity. Relevant characteristics of the life cycle of the tick colony are recorded. The pre-feeding and feeding periods and the mortality in the feeding period are determined. The pre-feeding periods is the time elapsed from when the ticks were released into the chambers until they attached to the host's skin. The feeding period is the time elapsed from when the ticks were released into the chambers until the engorged ticks drop off naturally. This latter period includes the pre-feeding period. When the tick species is a three-host tick, fed larvae or fed nymphs are kept separately in glass flasks in the incubator under the selected conditions and are observed daily to determine the molting period to the next stage and the mortality in this period. Dropped-off, engorged females are collected, washed in PBS 1×, and dried on filter paper (Whatman 3 MM). They are identified and weighed individually. Each

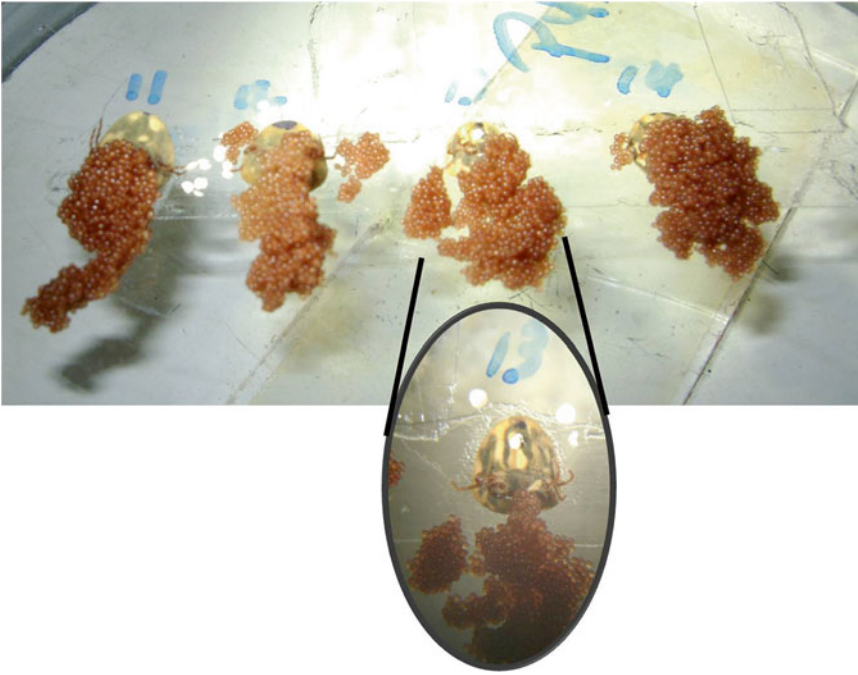

Fig. 2 Engorged females stuck with dorsal side down on double sided tape of a disposable petri dish, to prevent movement, and also prevent obstruction of the egg exiting from the genital opening. Females are maintained in the incubator during oviposition

engorged female is stuck dorsal side down, on double-sided tape in a disposable petri dish [54] (Fig. 2) and maintained in the incubator during oviposition. The pre-oviposition and oviposition periods are recorded. The pre-oviposition period is the elapsed time between the engorged female detaching and the oviposition starting. The oviposition period is the elapsed time from when the first egg appears until eggs ceased to emerge from the genital opening. The egg mass laid by each female is weighed. The conversion efficiency index (CEI) is calculated as the percentage of the female's weight converted into eggs, according to Bennett [55]. Pearson's correlation coefficients (r) between female weight and pre-oviposition period, oviposition period, the CEI, and the egg weight are calculated using Prism statistical software (GraphPad Software, San Diego, California, USA). The incubation period of eggs and the percentage of hatched larvae are determined. Each egg mass is incubated separately in glass vials under the incubator conditions. When the hatching is completed, the larvae are counted. The hatching percentage is calculated as the number of larvae/number of eggs $\times 100$ where the number of eggs was calculated as egg mass weight/weight of one egg, which is determined previously. For this, the number of eggs in more than 100 egg masses, previously weighed, is counted under the

stereoscope. The weight of one egg is determined by dividing the weight of each egg mass by the corresponding number of eggs. The average among all determinations is taken as the weight of one egg. From this point, the egg number laid by an engorged female is determined by dividing the egg mass weight by this one-egg weight.

5. As discussed above the antigen can be “exposed” or “concealed”. Recent data on antigenic proteins demonstrated that the house keeping-like proteins are immunogenic, and thus could be considered for anti-tick vaccine antigens [56]. Given that housekeeping proteins tend to be highly conserved across taxa, the development of a vaccine candidate against ticks based on this class of proteins must avoid phenomena of tolerance or autoimmunity in the host. One strategy for avoiding these phenomena can be the selection of peptides of the amino acid sequence of these conserved proteins with the lowest identity of sequence to the corresponding region in the mammalian protein.
6. The antigens can be produced by either recombinant DNA technology or by the use of peptide chemistry.
7. In general, the peptide-based vaccines contain B epitopes against which the antibody response is desired and the recognition site of the T cells is provided by a carrier protein to which peptides are covalently coupled. The selection of the carrier protein is important to achieve the functionality of the conjugate since it must be a highly immunogenic protein. Among the most commonly proteins used are bovine serum albumin (BSA) [57], ovalbumin [58], and keyhole limpet hemocyanin (KLH) [59–61] due to their numerous epitopes, their high molecular mass and their proven efficiencies in different vaccine preparations. Immune system molecules of the host itself can be incorporated to selected antigens, as adjuvants of the immune response or chimeric fusion proteins can be designed to enhance the immune response. The immunogens can be prepared with Montanide (in an aqueous formulation or water-in-oil emulsion), mineral oil, or aluminum hydroxide gel. The selection of adjuvants depends on the target species.
8. Wherever possible, the selected mammalian hosts must be one that can be obtained from commercial suppliers of laboratory animals with a stable phenotype, which allows for increasing the sample size, and must have a size that supports simultaneous infestation with different tick stages and should be cheaper than species such as sheep, cattle, or horses.
9. The immunization schedule will depend on the kind of antigen. If the antigen is “exposed,” the immunization schedule will not require the repeated immunizations. If the antigen is “concealed,” several immunizations are needed, but it is important

performing the minimal immunizations to achieve the desired biological effect with the minimum cost.

10. The IgG antibody response against the immunogens can be evaluated by indirect ELISA. Animal serum samples must be taken on days prior to the immunizations and after challenge. One hundred nanograms per well of purified antigen in 100 μ L of 1 \times coating is used to coat polysorp ELISA plates overnight at 4 $^{\circ}$ C. The plates are washed three times with an excess volume of PBS 1 \times plus 0.05 % of Tween 20, then blocked for at least 1 h at 37 $^{\circ}$ C with agitation using 200 μ L per well of 2 % nonfat milk in PBS 1 \times . Sera are serially diluted in base 1:2 in PBS 1 \times . The plates are incubated with 50 μ L of the sera serial dilutions for 1 h at 37 $^{\circ}$ C, with agitation and after washes as above, incubated with 1:10,000 anti-host IgG conjugated to horseradish peroxidase for 1 h at 37 $^{\circ}$ C. The plates are washed again and the color reaction is developed with the substrate solution. The reaction is stopped with 2.5 M H₂SO₄ and the OD_{490 nm} is determined. The antibody titer is established as the reciprocal of the highest dilution, at which the mean OD of the serum in question is three times the mean OD of the negative control serum. The antibody titer mean is determined from individual values in each group.
11. When the model tick species is a one-host tick, each mammalian host is infested with approximately 3000 larvae of ticks. Ticks are released inside three feeding chambers (1000 larvae in each chamber in a staggered manner). If the tick species is a three-host tick, each mammalian host is infested with larvae from 20 mg of eggs, 100 nymphs and 40 adults (20 males and 20 females) ticks. Ticks are released inside feeding chambers (each stage in an independent chamber).
12. When the model tick species is a one-host tick, the collection, counting, and weighing of engorged females is performed. Females are immobilized as described previously in **Note 4**. The average time from the infestation of larvae to the detachment of the engorged females is determined in each experimental group and the mean yield of females by group is calculated in percentage as the number of females recovered in each animal compared to the number of infested larvae. This value represents the mortality in the feeding period. Female viability after feeding is calculated as the ratio between the average of females capable to lay eggs and the average of females recovered after tick feeding in each experimental group. The engorged female's weight, the egg mass' weight, and their hatching rate are also recorded. The efficiency of conversion to eggs is calculated as the female weight percentage converted to eggs [55]. When the tick species is a three-host tick, in addition to the same parameters studied for the one-host ticks, the average of the

feeding period, the yield and the molting process for larvae and nymphs are also recorded. As for adults, the yield of larvae and nymphs represents the mortality during the feeding period. After feeding, in both cases, viability in the molting process is calculated as the ratio between the number of viable ticks in the newly molted stage and the number of fed ticks recovered from animals in the previous stage. All data from the experimental groups are compared by suitable statistical method using GraphPad Prism (GraphPad Software, USA). Proportion data are transformed to the arcsine of its square root prior to the statistical analysis.

13. Taking into account the basic concepts established to calculate anti-tick vaccine efficacy in one-host tick [22, 33, 62–64], a universal method must be established to calculate the overall efficacy (E) of a studied antigen. This will standardize the results and comparisons between efficacies determined by different laboratories with different antigens. Then, E must be defined in percentage including all effects that must be measured on each tick stage depending on the life cycle of the selected model tick. Thus:

$$E (\%) = 100 \times [1 - (\text{RL} \times \text{VL} \times \text{RN} \times \text{VN} \times \text{RA} \times \text{PA} \times \text{VA} \times \text{OA} \times \text{E})]$$

where,

RL is the effect of the immunogen on the yield of larvae. It is calculated as the ratio between the average of larvae recovered from the group vaccinated with antigen (rlv) and the average of larvae recovered from the control group (rlc). $\text{RL} = (\text{rlv} / \text{rlc})$. This value represents the mortality during the feeding period.

VL is the effect of the immunogen on larval viability in the molting process. It is calculated as the ratio between the average of viable nymphs newly molted from fed larvae (vlv) and the average of fed larvae recovered (rlv) from animals vaccinated with antigen divided by the same ratio in the control group (vlc/rlc). $\text{VL} = (\text{vlv} / \text{vlc}) \times (\text{rlc} / \text{rlv})$.

RN is the effect of the immunogen on the yield of nymphs. It is calculated as the ratio between the average of nymphs recovered from the animals vaccinated with antigen (rnv) and the average of nymphs recovered from the control group (rnc). $\text{RN} = (\text{rnv} / \text{rnc})$. This value represents the mortality during the feeding period.

VN is the effect of the immunogen on the nymphs' viability in the molting process. It is calculated as the ratio between the average of viable adults newly molted from fed nymphs (vnv) and the average of fed nymphs recovered (rnv) from animals vaccinated with antigen divided by the same ratio in the control group (vnc/rnc). $\text{VN} = (\text{vnv} / \text{vnc}) \times (\text{rnc} / \text{rnv})$.

RA is the effect of the immunogen on the yield of females. It is calculated as the ratio between the average of females recovered from the group vaccinated with antigen (rav) and the average of females recovered from the control group (rac). $RA = (rav/rac)$. This value represents the mortality during the feeding period.

PA is the effect of the immunogen on the females' weight. It is calculated as the ratio between the average of the females' weight recovered from the group vaccinated with antigen (ewv) and the average of the females' weight recovered from the control group (ewc). $OA = (ewv/ewc)$.

VA is the effect of the immunogen on the females' viability during the oviposition period. It is calculated as the ratio between the number of females able to lay eggs (vav) and the number of engorged females recovered from the group vaccinated with antigen (rav) compared to the same ratio in the control group (vac/rac). $VA = (vav/rav) \times (rac/vac)$.

OA is the effect of the immunogen on the females' oviposition. It is calculated as the ratio between the average weight of the egg masses of engorged females recovered from the group vaccinated with antigen (ewv) and the average weight of the egg masses laid by engorged females recovered from the control group (ewc). $OA = (ewv/ewc)$.

FE is the effect of the immunogen on the eggs fertility. It is calculated as the ratio between the average of larvae obtained (hlv) and the average of eggs laid by ticks fed on animals vaccinated with the antigen (elv) divided by the same parameters for the control. $FE = (hlv/elv) \times (elc/hlc)$.

In case the model is one-host tick, all parameters referred to the effects on larvae and nymphs are eliminated from the formula because these effects are included in the effects of the immunogen that are observed on the yield of females. That is because in this case, all tick parasitic stages were fed on the same vaccinated host and the observed effect on the females is the cumulative effect on each stage.

As described above in this Note, the efficiency of conversion to eggs is calculated as the female weight percentage converted to eggs. As previously described, in normal conditions, the weight of engorged females and amount of eggs which females produce is correlated and each female is able to convert half of her body weight in eggs [65, 66]. When this parameter does not give statistically significant differences between the experimental group vaccinated with the antigen and the control group vaccinated with placebo, it means that the egg conversion ratio is similar for both groups (no influence from the vaccine). In this case only one of the parameters, PA or OA should be included in the formula.

When the studied parameter does not give significant differences between the experimental group vaccinated with the antigen and the control group vaccinated with placebo, the term related to this parameter is 1 and it does not affect the overall efficacy.

References

1. Parola P, Raoult D (2001) Ticks and tickborne bacterial diseases in humans: an emerging infectious threat. *Clin Infect Dis* 32:897–928
2. Jongejans F, Uilenberg G (2004) The global importance of ticks. *Parasitology* 129(Suppl): S3–S14
3. George JE, Pound JM, Davey RB (2004) Chemical control of ticks on cattle and the resistance of these parasites to acaricides. *Parasitology* 129(Suppl):S353–S366
4. Parra MH, Peláez SL, Segura CF, Arcos JC, Londoño A, Díaz E, Vanegas MA (1999) Manejo integrado de garrapatas en bovinos. *Ser Mod Capacit Tecnol Agro* 2:72–77
5. Fyumagwa RD, Runyoro V, Horak IG, Hoare R (2007) Ecology and control of ticks as disease vectors in wildlife of the Ngorongoro Crater, Tanzania. *S Afr J Wildl Res* 37:79–90
6. Chapin Iii FS, Zavaleta ES, Eviner VT, Naylor RL, Vitousek PM, Reynolds HL, Hooper DU, Lavorel S, Sala OE, Hobbie SE, Mack MC, Diaz S (2000) Consequences of changing biodiversity. *Nature* 405:234–242
7. de la Fuente J, Kocan KM (2006) Strategies for development of vaccines for control of ixodid tick species. *Parasite Immunol* 28:275–283
8. Castagnolli KC, de Figueiredo LB, Santana DA, de Castro MB, Romano MA, Szabo MP (2003) Acquired resistance of horses to *Amblyomma cajennense* (Fabricius, 1787) ticks. *Vet Parasitol* 117:271–283
9. Louly CC, Soares SF, da Nobrega SD, Guimaraes MS, Borges LM (2010) Differences in the behavior of *Rhipicephalus sanguineus* tested against resistant and susceptible dogs. *Exp Appl Acarol* 51:353–362
10. Willadsen P (1987) Immunological approaches to the control of ticks. *Int J Parasitol* 17:671–677
11. Willadsen P, McKenna RV, Riding GA (1988) Isolation from the cattle tick, *Boophilus microplus*, of antigenic material capable of eliciting a protective immunological response in the bovine host. *Int J Parasitol* 18:183–189
12. Willadsen P (2004) Anti-tick vaccines. *Parasitology* 129(Suppl):S367–S387
13. Nuttall PA, Trimnell AR, Kazimirova M, Labuda M (2006) Exposed and concealed antigens as vaccine targets for controlling ticks and tickborne diseases. *Parasite Immunol* 28:155–163
14. Willadsen P, Kemp DH (1988) Vaccination with ‘concealed’ antigens for tick control. *Parasitol Today* 4:196–198
15. Trimnell AR, Hails RS, Nuttall PA (2002) Dual action ectoparasite vaccine targeting ‘exposed’ and ‘concealed’ antigens. *Vaccine* 20:3560–3568
16. de La Fuente J, Rodriguez M, Garcia-Garcia JC (2000) Immunological control of ticks through vaccination with *Boophilus microplus* gut antigens. *Ann N Y Acad Sci* 916:617–621
17. Rand KN, Moore T, Sriskantha A, Spring K, Tellam R, Willadsen P, Cobon GS (1989) Cloning and expression of a protective antigen from the cattle tick *Boophilus microplus*. *Proc Natl Acad Sci U S A* 86:9657–9661
18. Willadsen P, Riding GA, McKenna RV, Kemp DH, Tellam RL, Nielsen JN, Lahnstein J, Cobon GS, Gough JM (1989) Immunologic control of a parasitic arthropod. Identification of a protective antigen from *Boophilus microplus*. *J Immunol* 143:1346–1351
19. Bastos RG, Ueti MW, Knowles DP, Scoles GA (2010) The *Rhipicephalus (Boophilus) microplus* Bm86 gene plays a critical role in the fitness of ticks fed on cattle during acute *Babesia bovis* infection. *Parasit Vectors* 3:111
20. Penichet M, Rodriguez M, Castellano O, Mandado S et al (1994) Detection of Bm86 antigen in different strains of *Boophilus microplus* and effectiveness of immunization with recombinant Bm86. *Parasite Immunol* 16:493–500
21. Gough JM, Kemp DH (1993) Localization of a low abundance membrane protein (Bm86) on the gut cells of the cattle tick *Boophilus microplus* by immunogold labeling. *J Parasitol* 79:900–907
22. de la Fuente J, Rodriguez M, Montero C, Redondo M et al (1999) Vaccination against ticks (*Boophilus spp.*): the experience with the Bm86-based vaccine Gavac. *Genet Anal* 15:143–148

23. Rodríguez-Vivas R, Rosado A, Basto G, Sotero Z, Rosario R, Fragoso H (2006) Manual técnico para el control de garrapatas en el ganado bovino. Centro Nacional de Investigación Disciplinaria en Parasitología Veterinaria, Jiutepec, Morelos, México
24. Redondo M, Fragoso H, Ortiz M, Montero C et al (1999) Integrated control of acaricide-resistant *Boophilus microplus* populations on grazing cattle in Mexico using vaccination with Gavac and amidine treatments. *Exp Appl Acarol* 23:841–849
25. de la Fuente J, Almazan C, Canales M, Perez de la Lastra JM, Kocan KM, Willadsen P (2007) A ten-year review of commercial vaccine performance for control of tick infestations on cattle. *Anim Health Res Rev* 8:23–28
26. Sauer JR, McSwain JL, Essenberg RC (1994) Cell membrane receptors and regulation of cell function in ticks and blood-sucking insects. *Int J Parasitol* 24:33–52
27. Wang H, Nuttall PA (1994) Excretion of host immunoglobulin in tick saliva and detection of IgG-binding proteins in tick haemolymph and salivary glands. *Parasitology* 109:525–530
28. Jasinskas A, Jaworski DC, Barbour AG (2000) *Amblyomma americanum*: specific uptake of immunoglobulins into tick hemolymph during feeding. *Exp Parasitol* 96:213–221
29. Guerrero FD, Miller RJ, Pérez de León AA (2012) Cattle tick vaccines: many candidate antigens, but will a commercially viable product emerge? *Int J Parasitol* 42:421–427
30. Parizi LF, Pohl PC, Masuda A, Vaz Ida S Jr (2009) New approaches toward anti-*Rhipicephalus (Boophilus) microplus* tick vaccine. *Rev Bras Parasitol Vet* 18:1–7
31. Antunes S, Merino O, Lérias J, Domingues N, Mosqueda J, de la Fuente J, Domingos A (2015) Artificial feeding of *Rhipicephalus microplus* female ticks with anti calreticulin. *Ticks Tick Borne Dis* 6:47–55
32. Hajdusek O, Sojka D, Kopacek P, Buresova V et al (2009) Knockdown of proteins involved in iron metabolism limits tick reproduction and development. *Proc Natl Acad Sci U S A* 106:1033–1038
33. Hajdusek O, Almazan C, Loosova G, Villar M et al (2010) Characterization of ferritin 2 for the control of tick infestations. *Vaccine* 28:2993–2998
34. Almazan C, Moreno-Cantu O, Moreno-Cid JA, Galindo RC et al (2012) Control of tick infestations in cattle vaccinated with bacterial membranes containing surface-exposed tick protective antigens. *Vaccine* 30:265–272
35. Trimnell AR, Davies GM, Lissina O, Hails RS, Nuttall PA (2005) A cross-reactive tick cement antigen is a candidate broad-spectrum tick vaccine. *Vaccine* 23:4329–4341
36. Rodríguez-Mallon A, Fernández E, Encinosa PE, Bello Y et al (2012) A novel tick antigen shows high vaccine efficacy against the dog tick, *Rhipicephalus sanguineus*. *Vaccine* 30:1782–1789
37. Heldens JGM, Patel JR, Chanter N, Ten Thij GJ et al (2008) Veterinary vaccine development from an industrial perspective. *Veter J* 178:7–20
38. Brake DK, Pérez de León AA (2012) Immunoregulation of bovine macrophages by factors in the salivary glands of *Rhipicephalus microplus*. *Parasit Vectors* 5:38
39. Jackson DC, O'Brien-Simpson N, Ede NJ, Brown LE (1997) Free radical induced polymerization of synthetic peptides into polymeric immunogens. *Vaccine* 15:1697–1705
40. Deres K, Schild H, Wiesmuller KH, Jung G, Rammensee HG (1989) In vivo priming of virus-specific cytotoxic T lymphocytes with synthetic lipopeptide vaccine. *Nature* 342:561–564
41. Altschul SF, Madden TL, Schaffer AA, Zhang JH et al (1997) Gapped BLAST and PSIBLAST: a new generation of protein database search programs. *Nucleic Acids Res* 25:3389–3402
42. Thompson JD, Gibson TJ, Plewniak F, Jeanmougin F, Higgins DG (1997) The CLUSTAL X windows interface: flexible strategies for multiple sequence alignment aided by quality analysis tools. *Nucleic Acids Res* 25:4876–4882
43. Tamura K, Dudley J, Nei M, Kumar S (2007) MEGA4: molecular evolutionary genetics analysis (MEGA) software version 4.0. *Mol Biol Evol* 24:1596–1599
44. Bowman A, Nuttall P (2008) Ticks: biology, disease and control. Cambridge University Press, Cambridge
45. Chen Z, Li SS, Liu JZ (2011) Illustrated keys to families and genera of the superfamily Ixodoidea under new taxonomic system. *Zhongguo Ji Sheng Chong Xue Yu Ji Sheng Chong Bing Za Zhi* 29(302-4):309
46. Estrada-Peña A, Bouattour A, Camicas J, Walker A (2004) Ticks of domestic animals in the Mediterranean region. A guide to identification of species. University of Zaragoza, Zaragoza, España
47. Black WC, Klompen JS, Keirans JE (1997) Phylogenetic relationships among tick subfamilies (Ixodida: Ixodidae: Argasidae) based on the 18S nuclear rDNA gene. *Mol Phylogenet Evol* 7:129–144
48. Cruickshank RH (2002) Molecular markers for the phylogenetics of mites and ticks. *Syst Appl Acarol* 7:3–14
49. Chen Z, Li Y, Liu Z, Yang J, Yin H (2012) The life cycle of *Hyalomma rufipes* (Acari: Ixodidae) under laboratory conditions. *Exp Appl Acarol* 56:85–92
50. Labruna MB, Cabrera RR, Pinter A (2009) Life cycle of *Ixodes luciae* (Acari: Ixodidae) in the laboratory. *Parasitol Res* 105:1749–1753

51. Chen Z, Yu Z, Yang X, Zheng H, Liu J (2009) The life cycle of *Hyalomma asiaticum* kozlovi Olenov, 1931 (Acari: Ixodidae) under laboratory conditions. *Vet Parasitol* 160:134–137
52. Troughton DR, Levin ML (2007) Life cycles of seven ixodid tick species (Acari: Ixodidae) under standardized laboratory conditions. *J Med Entomol* 44:732–740
53. The National Academies Press (2011) Guide for the care and use of laboratory animals. 8th edition
54. Gallardo J, Morales J (1999) *Boophilus microplus* (Acari: Ixodidae): preoviposición, oviposición, incubación de los huevos y geotropismo. *Bioagro* 11:77–87
55. Bennett GF (1974) Oviposition of *Boophilus microplus* (Canestrini) (Acarida: Ixodidae). II. Influence of temperature, humidity and light. *Acarologia* 16:251–257
56. Radulović ŽM, Kim TK, Porter LM, Sze SH, Lewis L, Mulenga A (2014) A 24–48 h fed *Amblyomma americanum* tick saliva immunoproteome. *BMC Genomics* 15:518
57. Jahouh F, S-j H, Kováč P, Banoub JH (2012) Determination of glycation sites by tandem mass spectrometry in a synthetic lactose-bovine serum albumin conjugate, a vaccine model prepared by dialkyl squarate chemistry. *Rapid Commun Mass Spectrom* 26:749–758
58. Simerska P, Ziora Z, Fagan V, Goodwin D, Edrous F, Toth I (2013) Design, synthesis and characterisation of mannosylated ovalbumin lipid core peptide self-adjuvanting vaccine delivery system. *Drug Deliv Transl Res* 4:246–255
59. Gil FI, Brun A, Wigdorovitz A, Catalá R, Martínez-Torrecuadrada JL et al (2001) High yield expression of a viral peptide vaccine in transgenic plants. *FEBS Lett* 488:13–17
60. Langeveld JPM, Casal I, Cortés J, Van de Wetering E et al (1994) Effective induction of neutralizing antibodies with the amino terminus of VP2 of canine parvovirus as a synthetic peptide. *Vaccine* 12:1473–1480
61. Langeveld JP, Casal JI, Osterhaus AD, Cortes E et al (1994) First peptide vaccine providing protection against viral infection in the target animal: studies of canine parvovirus in dogs. *J Virol* 68:4506–4513
62. Canales M, Enriquez A, Ramos E, Cabrera D, Dandie H et al (1997) Large-scale production in *Pichia pastoris* of the recombinant vaccine Gavac against cattle tick. *Vaccine* 15:414–422
63. de la Fuente J, Rodriguez M, Redondo M, Montero C et al (1998) Field studies and cost-effectiveness analysis of vaccination with Gavac against the cattle tick *Boophilus microplus*. *Vaccine* 16:366–373
64. Almazan C, Kocan KM, Bergman DK, Garcia-Garcia JC, Blouin EF, de la Fuente J (2003) Identification of protective antigens for the control of *Ixodes scapularis* infestations using cDNA expression library immunization. *Vaccine* 21:1492–1501
65. Davey RB, Garza J, Thompson GD, Drummond RO (1980) Ovipositional biology of the southern cattle tick, *Boophilus microplus* (Acari: Ixodidae) in the laboratory. *Ann Entomol Soc Amer* 75:583–586
66. Bechara GH, Szabó MPJ, Ferreira BR (1995) *Rhipicephalus sanguineus* tick in Brazil: feeding and reproductive aspects under laboratorial conditions. *Braz J Vet Parasitol* 4:61–66

Chapter 18

Host Immunization with Recombinant Proteins to Screen Antigen for Tick Control

Remil Linggatong Galay, Takeshi Miyata, Rika Umemiya-Shirafuji, Masami Mochizuki, Kozo Fujisaki, and Tetsuya Tanaka

1 Introduction

Ticks are the primary vectors of many pathogens in animals and are considered second to mosquitoes in transmitting diseases to humans [1, 2]. Babesiosis, rickettsiosis, and tick-borne encephalitis are among the common tick-borne diseases (TBDs) that continue to affect both humans and animals worldwide [3]. Tick control is obviously an integral part of controlling these TBDs, and until now relies heavily on the application of chemical acaricides, particularly in livestock production. However, the continuous development of resistance of many tick species, as well as active concerns on chemical contamination of animal products and the environment, make this control method less desirable. Therefore, alternative methods for tick control are necessary.

Vaccination against ticks and TBDs has long been considered to be a better alternative to chemical acaricides [4]. Using recombinant proteins to immunize the host, antibodies will target particular antigens in the ticks, thus offering a health and environment risk-free control method and a low tendency for resistance development in ticks [5]. For 20 years already, the first and until recently remains to be the only commercially available anti-tick vaccine utilizes the midgut protein Bm86 from the hard tick *Rhiphicephalus (Boophilus) microplus* [6]; however, this vaccine is ineffective against other tick species and its effectiveness against *R. microplus* also varies with strain [7]. A universal anti-tick vaccine that renders protection against multiple tick species is still lacking, and therefore many studies on ticks are aimed at identifying potential tick antigens. A review by Nuttall et al. [5] compared the two main types of tick antigens: exposed and concealed antigens.

Up to date, there are numerous candidate antigens with the potential of protecting the host from multiple tick species [7] and more are being identified using genomic and proteomic approaches [8, 9]. Among the promising candidate antigens is subolesin, shown to be effective not only against ticks, but to other arthropod vectors as well [10], and also in reducing the infection rate of two TBDs [11]. Vaccination against the secretory ferritin 2 of four hard tick species also showed significant results [12, 13].

This chapter describes the procedures on immunizing a laboratory animal, the rabbit, with a recombinant tick protein for the preliminary evaluation of its potential as a candidate anti-tick vaccine. In our laboratory, we are using an *Escherichia coli*-based expression system, the most widely used system for the synthesis of recombinant proteins [14] and will be described here in detail; however, other expression systems may be employed [15]. It is recommended that the readers refer also to the manual of the particular expression system that they will utilize to ensure high yield of good quality recombinant proteins. The measurement of host antibody levels through enzyme-linked immunosorbent assay (ELISA), and the subsequent tick infestation challenge for determining the effectiveness of vaccination will also be described.

2 Materials

All media and buffers should be prepared using high-purity distilled water. In some cases, sterilized high-purity distilled water (i.e., autoclaved at 121 °C for 15 min) is used. Use clean and sterilized bottles or tubes. All buffers should be stored at 4 °C unless specified.

2.1 For Recombinant Protein Synthesis

1. Luria–Bertani (LB) broth: Dissolve 25 g of LB powder (Difco; Becton and Dickinson Company, Sparks, MD, USA) for every 1 L water (*see Note 1*). Autoclave at 121 °C for 15 min, and then cool at room temperature before storage or use (*see Note 2*). Add ampicillin at 50 µg/ml concentration (*see Note 3*).
2. *E. coli* stock expressing recombinant protein: Transformed competent BL21 (DE3) *E. coli* cells, containing the plasmid (e.g., pRSET B; Invitrogen, Carlsbad, CA, USA) inserted with the gene encoding the target protein, are placed in a cryotube with 1 ml equal volume of 30 % glycerol and LB broth with ampicillin. This should be stored at –80 °C.
3. 1 M isopropyl β-d-thiogalactopyranoside (IPTG): Prepare 1 ml aliquots (*see Note 4*) and store at –20 °C until use.
4. Phosphate buffered saline (PBS; 10×): 1.37 M NaCl, 100 mM Na₂HPO₄, 27 mM KCl, 18 mM KH₂PO₄. Autoclave at 121 °C for 15 min and then store at room temperature.
5. Urea Solution: 6 M urea, 20 mM Tris–HCl, 500 mM NaCl.

2.2 Recombinant Protein Purification and Refolding

1. Nickel sepharose column for Histidine (His)-binding: HisTrap FF (GE Healthcare, Uppsala, Sweden) 1 ml. Store at 4 °C (*see Note 5*).
2. Binding buffer: 20 mM Tris-HCl (pH 8.0), 0.5 NaCl, 6 M Urea. This solution should be filtered using a 0.45 µm syringe filter before use (*see Note 6*).
3. Elution buffer: 20 mM Tris-HCl (pH 8.0), 0.5 NaCl, 6 M Urea, 500 mM imidazole. Similar to binding buffer, this should be filtered before use (*see Note 6*).
4. BioLogic DuoFlow chromatography system (Bio-Rad, Hercules, CA, USA).
5. 0.5 M Arginine in PBS: Dissolve arginine in 1× PBS from the stock solution described above.

2.3 Rabbit Immunization

1. Rabbits: female, at least 2 months old and weighing around 2 kg. These should not have been infested before with ticks or used in any other experiments.
2. Freund's incomplete adjuvant (Sigma-Aldrich, St. Louis, MO, USA): store at 4 °C until use.
3. 2 ml glass syringes and micro-emulsifying needle (Sigma-Aldrich): sterilized by autoclaving at 121 °C for 15 min.
4. 21–23 G hypodermic needles: single use, disposable.

2.4 Measurement of Antibody Titer through ELISA

1. For blood collection: 23–25 G hypodermic needle and 3–5 ml disposable syringe.
2. Rabbit serum as a primary antibody: after collecting blood, let it stand at room temperature for at least 30 min. Centrifuge at 22,140×g at 4 °C for 10 min. Transfer the serum in a new tube and store at –20 °C until use (*see Note 7*).
3. ELISA plate (F96 Maxisorp, Nunc, Roskilde, Denmark).
4. Recombinant protein: stored at –20 °C and thawed prior to use.
5. Carbonate buffer: 35 mM NaHCO₃, 15 mM Na₂CO₃, pH 9.6. Store at 4 °C.
6. 1× PBS with 0.05 % Tween 20 (PBS-T).
7. Blocking solution: 3 % skimmed milk dissolved in PBS-T.
8. Horseradish peroxidase (HRP)-conjugated anti-rabbit immunoglobulins: as a secondary antibody. Store at 4 °C.
9. TMB One Component HRP Microwell substrate (Surmodics Inc., Eden Prairie, MN, USA): Store at 4 °C.
10. 0.6 N H₂SO₄: Store at room temperature.
11. 1 N HCl: Store at room temperature.
12. Microplate reader (Bio-Rad) with 550 nm filter.

2.5 Tick Infestation Challenge

1. Ear bags: Cloth sewn for covering the ears of the rabbit.
2. Ticks: any stage, starved for 3 months preferably.
3. Containers for storing engorged ticks.

3 Methods

3.1 Large-Scale Recombinant Protein Synthesis and Extraction

1. Prepare a pre-culture by inoculating *E. coli* stock in 10 ml LB broth with ampicillin. Incubate at 37 °C with shaking at 144 rpm overnight or until the absorbance at OD₆₀₀ is around 1–2.
2. Add all the pre-culture to 500 ml LB broth with ampicillin and incubate at 37 °C with shaking at 170 rpm until OD₆₀₀ = 0.5.
3. Add IPTG at a final concentration of 1 mM and incubate further at 37 °C with shaking at 110 rpm for 4 h or overnight (*see Note 8*).
4. Collect the cells by centrifugation at 3350 × *g* for 30 min at 4 °C. Remove the supernatant (medium) and resuspend the cells in 5 ml diluted (1×) PBS (*see Note 9*).
5. Transfer the cell suspension in a 50 ml tube and place on ice.
6. Set the hand ultrasonicator as follows: amplitude—30, timer—1 min, pulse—1. Sonicate the cell suspension thrice while on ice (*see Note 10*).
7. Centrifuge at 3350 × *g* for 5 min at 4 °C. Repeat sonication as described above and centrifuge again.
8. After another round of sonication, centrifuge at 3350 × *g* for 30 min at 4 °C.
9. Transfer the supernatant to a new tube. This is the PBS soluble fraction. Resuspend the pellet in 10 ml sterilized high-purity distilled water.
10. Sonicate and centrifuge as in **steps 7–9**.
11. After the third centrifugation, transfer the supernatant into a new tube. This is the water soluble fraction (*see Note 11*). Add 10 ml of 6 M urea solution to the pellet without disturbing it.
12. Place the tube containing the pellet and urea solution in an automatic rotator overnight at 4 °C and set it in a very low speed. The pellet should be completely dissolved.
13. Centrifuge at 3350 × *g* for 30 min at 4 °C the following day.
14. Obtain the supernatant and transfer into a new tube. This is the urea soluble fraction. Resuspend the remaining pellet (insoluble fraction) in 10 ml urea (*see Note 11*).

3.2 Purification and Refolding of Recombinant Protein

1. After confirming the presence of protein through sodium dodecyl sulfate polyacrylamide gel electrophoresis (SDS-PAGE), filter the urea soluble fraction using a 0.45 µm syringe filter.

2. Clean the tubes of BioLogic DuoFlow chromatography machine with high-purity distilled water, and then put one tube to binding buffer and another to elution buffer.
3. Wash the tubes with the respective buffer by running the machine for 5 min each buffer.
4. Attach the HisTrap FF column to the machine (*see Note 12*). Wash the column with elution buffer first for 5 min, followed by binding buffer for 5 min, and lastly high-purity distilled water for 10 min.
5. Prepare a running protocol. Below is a sample protocol (*see Note 13*):

Buffer	Running volume (ml)
Binding buffer	5
Urea soluble fraction (sample)	10
Binding buffer	15
Elution buffer	15
Binding buffer	10

6. Program the machine to collect fractions at the volume of 1 ml per tube at the same time of running the elution buffer.
7. Run the programmed protocol (*see Note 14*). After run, wash the column with 5 ml of the following in order: elution buffer, high-purity water, 1 M NaOH (flow rate 0.4 ml/min), high-purity distilled water, binding buffer, 20 % ethanol.
8. Check for the recombinant protein content of the fractions through SDS-PAGE.
9. Pool the fractions with the recombinant protein in a dialysis bag (*see Note 15*).
10. Place the dialysis bag in a beaker with magnetic stirrer containing 1 L of 0.5 M Arginine in 1× PBS solution. Place the dialysis setup at 4 °C. Set the speed of the stirrer to the lowest setting and keep it overnight.
11. The next day, transfer the dialysis bag in another beaker containing 1 L PBS only and keep in a similar condition as above overnight.
12. Recover the contents of the dialysis bag and centrifuge at 3350 × *g* for 30 min at 4 °C.
13. Obtain the supernatant. If there are pellets at the bottom of the tube, as in the case of insoluble proteins, dissolve using binding buffer and repeat the whole dialysis process.
14. Check the refolded protein using SDS-PAGE. Check also the concentration before storing in small aliquots at -20 °C.



Fig. 1 Two syringes, one containing recombinant protein and the other containing adjuvant, connected by a micro-emulsifying needle

3.3 Rabbit Immunization

1. Prepare the vaccine: Draw equal amounts of adjuvant and recombinant protein in two separate glass syringes (*see Note 16*) and connect the syringes with a micro-emulsifying needle (Fig. 1). To mix manually, alternately push the syringe plunger towards the opposite syringe to transfer its contents. Do this slowly and repeatedly for at least 10 min to ensure that the vaccine has been mixed thoroughly (*see Note 17*). Finally, place all the vaccine mixture in one syringe and replace the emulsifying needle with a hypodermic needle. For the control rabbit, prepare a syringe containing 1 ml of adjuvant only.
2. Take the rabbit out of the cage by grasping the loose skin around the back of its shoulder by one hand and supporting the hind quarters with another hand. If there is an assistant, the assistant can restrain the rabbit by holding it in the shoulder area with one hand and applying pressure in the rump area with another hand. If the injection will be done only by one person, the rabbit can be placed on the floor, and its body positioned between the thighs of the person that will do the procedure to restrict its movement.
3. To do a subcutaneous injection, lift the skin to make a triangular area (*see Note 18*). Disinfect the injection site using cotton soaked in 70 % ethanol. Insert the needle at the middle of the base of triangle made, making sure that the needle does not come out of the skin opposite the insertion site. Aspirate first to ensure proper placement of the needle, and then slowly inject all the vaccine mixture. Rub the injection site to distribute the vaccine.
4. Repeat the vaccination twice at 2-week interval to increase antibody titer.



Fig. 2 Blood may be collected from the marginal ear veins. Restrain the rabbit properly and clip the hairs to easily visualize the veins. Hold the proximal part of the ear to act as a tourniquet. *Arrow* points to our recommended site of needle insertion

3.4 Blood Collection and Measurement of Antibody Titer

1. To collect blood from the ear of the rabbit, ask an assistant to restrain the rabbit or use a restraint box to ensure that the rabbit is immobilized. Clip the hairs in the ear for better visualization of the veins. Gently tap the vein while grasping the proximal part of the ear near the base to act as a tourniquet (Fig. 2). Disinfect the collection site using cotton soaked in 70 % ethanol. Insert the needle and once blood is seen at the base of the needle, slowly aspirate. Once the desired amount of blood has been collected (at least 1 ml), apply pressure using dry cotton at the collection site before pulling the needle (*see Note 19*).
2. Prepare the serum as described in the Subheading 2.4, item 2.
3. To coat ELISA plate with recombinant protein, dilute the recombinant protein in carbonate buffer in a tube to a concentration of 1 $\mu\text{g}/\text{ml}$. Put 100 μl of the recombinant protein solution in each well using a multichannel pipette, so that each well will contain 100 ng of recombinant protein. Cover the plate and incubate overnight at 4 $^{\circ}\text{C}$.
4. The next day, discard the recombinant protein solution, and then wash the ELISA plate with PBS-T, three times. Tap the plate in a pile of tissue to remove the remaining wash solution after the third wash.
5. Place 150 μl of blocking solution per well, cover the plate, and then incubate at 37 $^{\circ}\text{C}$ for 1 h.
6. Remove the blocking buffer, and then wash the plate with PBS-T once.

7. Incubate the plate with the primary antibody diluted serially (*see Note 20*) by placing 100 μl of blocking solution in all wells first, and then adding the serum in the leftmost column, mixing several times using the pipette. Next, transfer a certain amount of the diluted antibody solution to the next well on its right, mixing several times before and after transferring (*see Note 21*). Proceed with the serial dilution until the last column has been reached. A row containing only blocking solution to serve as “blank” should be also prepared. Cover the plate and incubate at 37 °C for 1 h.
8. Remove the primary antibody solution, and then wash with PBS-T at least six times. Tap the plate in a pile of tissue to remove the remaining wash solution after the last wash.
9. Place 100 μl of diluted HRP-conjugated secondary antibody in blocking solution (1:2000 dilution) per well. Incubate the plate at 37 °C for 1 h.
10. Remove the second antibody solution, and then wash as in **step 8**.
11. Place 100 μl of TMB HRP Microwell substrate per well (*see Note 22*). Cover the plate with aluminum foil, and then incubate at 37 °C for 30 min.
12. Retrieve the ELISA plate from the incubator and stop the reaction by adding 100 μl of freshly prepared acid solution, consisting of equal volumes of 0.6 N H_2SO_4 and 1 N HCl per well.
13. Read absorbance in a microplate reader at 450 nm.
14. Check the antibody titer before immunization and a week after each vaccination.

3.5 Tick Infestation Challenge

1. Shave the ears of the rabbit, from the tip to the base (*see Note 23*).
2. Using a surgical suture and surgical needle, make two loops at the base of each ear: 1 in front and another in the back. Disinfect the area first before making the loops. This is where the ear bags will be attached.
3. Place small cotton inside each ear to prevent the ticks from entering the ear canal.
4. Attach the ear bags to the loops and secure further with adhesive bandage. Make sure that the bandage is not too tight to avoid impeding blood circulation
5. Distribute the ticks in two ears, such that each ear should have the same number of ticks (Fig. 3a).
6. Seal the tips of the ear bags with adhesive surgical tape.
7. Place an Elizabethan collar around the neck of the rabbit. Make sure that it is not too tight.

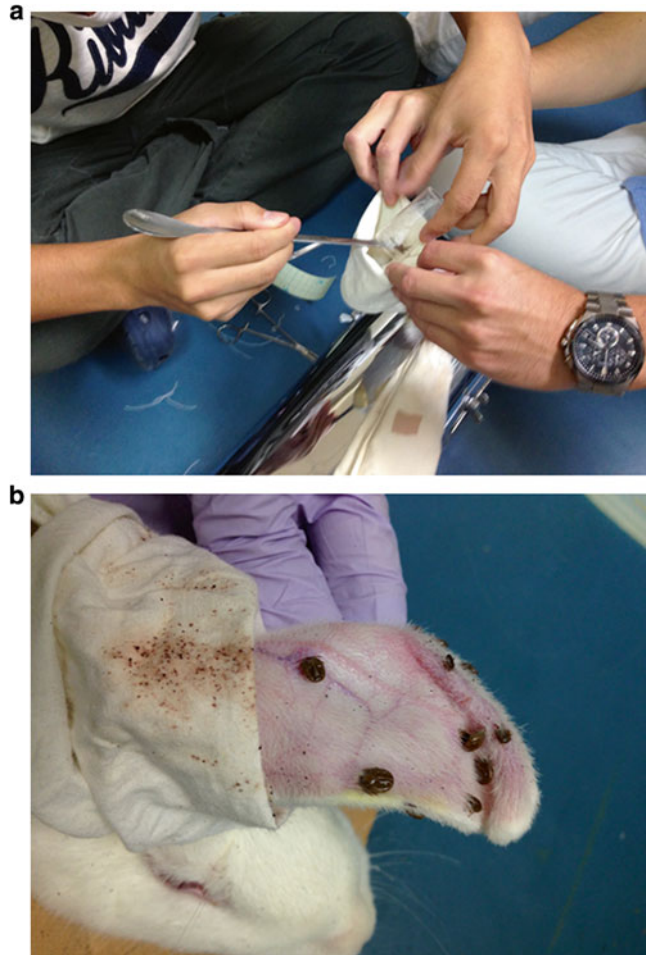

Fig. 3 Tick infestation challenge after vaccination. After placing the ear bags, equally distribute the ticks in each ear (a). Monitor the rabbits and tick attachment until the ticks complete feeding (b)

8. Monitor the rabbits and check tick attachment twice a day until the ticks fully engorge and drop naturally (Fig. 3b).
9. Count the number of ticks that fully engorged and measure their individual weight.
10. Place the engorged ticks on plastic tubes or vials with cotton plug. If using adult ticks, keep the ticks in individual vials. Otherwise, larvae and nymphs may be kept in groups of 40–100, depending on the size of the container. Place the containers with ticks in a glass chamber with a little water underneath for humidity and keep at 25 °C.
11. Observe the engorged adults for egg production through subsequent hatch. If using larvae and nymphs, observe the success of molting.
12. Calculate the tick parameters to determine vaccination efficacy (*see Note 24*).

4 Notes

1. If preparing in a beaker with magnetic stirrer, place all the water in the beaker and gradually add LB powder while being continuously stirred. If preparing in a flask, place half of the water in the flask and gradually add LB powder, shaking the flask rigorously every time LB is added. When half of medium has been dissolved, add more water and gradually dissolve the remaining LB powder in the same manner. It is recommended that the solution is warmed at 37 °C water bath to ensure the complete dissolution of LB powder.
2. A large amount of LB broth (e.g., 2 L) may be prepared in a large storage jar and then stored at 4 °C for use in preparing small quantity pre-cultures. For the scale-up expression, 500 ml LB broth should be prepared in a 1 L Erlenmeyer flask with fitted culture plug just a day before use. Cover the culture plug with aluminum foil before autoclaving.
3. Ampicillin solution may be prepared before hand and stored in small aliquots at -20 °C. It should be added to the medium if necessary just before use.
4. To prepare 20 ml 1 M IPTG, dissolve 4.77 g IPTG in 15 ml water. Place the solution in a graduated cylinder and then add water to a final volume of 20 ml. Filter the solution using a 0.20 µm syringe filter upon transferring to 1 ml tubes for storage.
5. The pRSET vector system (Invitrogen) that we use to prepare recombinant proteins in our laboratory produces poly-His fusion proteins. Other vector systems may utilize another protein tag, such as arginine and glutathione s-transferase (GST) that aids in increasing protein yield and purification [16]. Therefore, the choice of column for recombinant protein purification depends on the protein tag.
6. Binding and elution buffers should be immediately placed at 4 °C after preparation and can be used within a week.
7. It is better to repeat centrifugation to make sure that the clotted blood components are completely removed. Aliquot the serum in small quantities to prevent reduction in quality due to repeated thawing and freezing.
8. Obtain 1 ml aliquots of the culture prior to addition of IPTG, 4 h after addition of IPTG, and/or before centrifugation of the culture for collecting cells, to check the protein expression using SDS-PAGE.
9. In our laboratory, we divide the 500 ml culture into 2 capped plastic bottles during centrifugation.
10. Sonication may produce heat so make sure that the tube is embedded on ice during the whole process. Also, there should

be an interval of at least 1 min in between repetitions of sonication to minimize heat production.

11. The collected supernatants contain proteins that are soluble in PBS, water or urea. The pellet remaining after centrifugation of the urea suspension contains insoluble cell components. All the protein fractions should be stored at 4 °C and the protein profile should be checked through SDS-PAGE.
12. The flow rate should be reduced to 1 ml/min once the column has been attached to prevent damaging it. The column may be reused for purifying the same protein after cleaning as described in the methods section.
13. The running volume of the buffers should be adjusted based on the capacity of the column to be used. We recommend running at least 10 column volumes each of the binding and elution buffer after loading the sample. Please refer to the instruction manual of the particular column that will be used for optimum results.
14. While the machine is taking up the protein sample, it is advisable to collect the fraction coming out from the waste outlet as a safeguard from loss of protein.
15. Use a dialyzing membrane with a pore size that allows the escape of proteins with molecular weight lower than that of your recombinant protein.
16. The amount of the recombinant protein and adjuvant depends on the desired dose. We usually administer 100 µg of the recombinant protein per animal for each injection. So, for example, if the concentration of the recombinant protein stock is 1 mg/ml, dilute 200 µl of the stock protein with 300 µl of sterilized 1× PBS to get 0.5 ml recombinant protein, and then mix it with 0.5 ml adjuvant to obtain a final concentration of 100 µg/ml.
17. Since the resulting vaccine is oil-based, mixing should be done just prior to the administration to prevent the separation of components.
18. The preferred injection site is around the back of the neck or shoulder area since the skin there is loose, but care should be taken during injection because it is also easy to penetrate the skin opposite the insertion site, especially when using a long needle.
19. The common blood collection sites for small quantities of blood in rabbits are the marginal ear veins and the central ear artery. Other sites include jugular, cephalic, and lateral saphenous veins. We find it easier to collect in the marginal veins after wrapping the ears of the rabbit with warm towel for 1 min, which dilates the veins. We recommend collecting blood at the point where the vein bifurcates as pointed by the arrow in Fig. 2.

20. In performing logarithmic serial dilution of the primary antibody in our laboratory, we start with a 50× dilution in the first column by mixing 2.5 µl serum with 122.5 µl blocking solution. We then transfer 25 µl from one well to the next. After mixing the solution in the rightmost well or the last well with the highest dilution, 25 µl is discarded so that each well contains only 100 µl.
21. We recommend using a multichannel pipette and changing the pipette tips after transferring the solution from one well to the next. When working on several sera in a single ELISA plate, be careful not to let the pipette tip touch the sides of the adjacent wells intended for a different serum to avoid intermixing that may result to contamination.
22. The TMB Microwell substrate should be equilibrated to room temperature before using. Bring out the bottle from 4 °C storage and place at the working bench immediately after starting the incubation for secondary antibody.
23. If nymphs or larvae will be infested, the hairs should be shaved to as thin as possible, especially along the ear margins where most of the ticks are expected to attach. Thick and long hair may interfere with tick attachment.
24. We used the following formulas in calculating the reductions in engorged body weight, egg laying and hatch in our previous study [13] using adult ticks:
 - Reduction of tick engorged weight (R_w) = $100 [1 - (BWV/BWC)]$, where BWV is the average engorged weight of ticks infested on rHIFER vaccinated rabbits and BWC is the average engorged weight of ticks infested on the control rabbits.
 - Reduction of oviposition (R_o) = $100 [1 - (Ewv/Ewc)]$, where Ewv is the average weight of the eggs from ticks infested on rHIFER vaccinated rabbits and Ewc is the average weight of the eggs from ticks infested on the control rabbits.
 - Reduction on hatching (R_H) = $100 [1 - (AHV/AHC)]$, where AHV is the percent of ticks with completely hatched eggs from the total number of ticks that laid eggs from rHIFER vaccinated rabbits and AHC is the percent of ticks with completely hatched eggs to the total number of ticks that laid eggs from the control rabbits.
 - Vaccine efficacy (E) for each group was calculated as $100 [1 - (E_w \times E_o \times E_H)]$, where $E_w = BWV/BWC$, $E_o = Ewv/Ewc$, and $E_H = AHV/AHC$.
 - Cunha et al. [17] reviewed the different formulas in several anti-tick vaccination studies in cattle used on determining vaccine efficacy. If using nymphs and larvae, the effects of vaccination may be evaluated by calculating the reductions in the number of replete ticks, engorged body weight, and number of ticks that successfully molted [18].

Acknowledgements

This work was supported by the Japan Society for the Promotion of Science (JSPS) KAKENHI Grant Numbers 25292173 and 26660229, a joint research grant (26-joint-6) from the National Research Center for Protozoan Diseases, Obihiro University of Agriculture and Veterinary Medicine, and the Morinaga Foundation. We also thank Dr. Melbourne R. Talactac of the Laboratory of Infectious Diseases, Joint Faculty of Veterinary Medicine, Kagoshima University for technical assistance in the preparation of this chapter.

References

- de la Fuente J (2003) The fossil record and the origin of ticks (Acari: Parasitiformes: Ixodida). *Exp Appl Acarol* 29:437–446
- Jonjegan F, Uilenberg G (2004) The global importance of ticks. *Parasitology* 129:S3–S14
- Dantas-Torres F, Chomel B, Otranto D (2012) Ticks and tick-borne diseases: a one health perspective. *Trends Parasitol* 28:437–446
- Willadsen P (2006) Tick control: thoughts on a research agenda. *Vet Parasitol* 138:161–168
- Nuttall PA, Trimmell AR, Kazimirova M, Labuda M (2006) Exposed and concealed antigens as vaccine targets for controlling ticks and tick-borne diseases. *Parasite Immunol* 28:155–163
- Willadsen P, Bird P, Cobon GS, Hungerford J (1995) Commercialisation of a recombinant vaccine against *Boophilus microplus*. *Parasitology* 110:43–50
- Parizi LF, Githaka NW, Logullo C, Konnai S, Masuda A et al (2012) The quest for a universal vaccine against ticks: cross-immunity insights. *Vet J* 194:158–165
- de la Fuente J, Merino O (2013) Vaccinomics, the new road to tick vaccines. *Vaccine* 31:5923–5929
- Marcelino I, de Almeida AM, Ventosa M, Pruneau L, Meyer DF et al (2012) Tick-borne diseases in cattle: applications of proteomics to develop new generation vaccines. *J Proteomics* 75:4232–4250
- Moreno-Cid JA, de la Lastra JMP, Villar M, Jimenez M, Pinal R et al (2013) Control of multiple arthropod vector infestations with suboleisin/akirin vaccines. *Vaccine* 31:1187–1196
- Merino O, Antunes S, Mosqueda J, Moreno-Cid JA, Perez de la Lastra JM et al (2013) Vaccination with proteins involved in tick-pathogen interactions reduces vector infestations and pathogen infection. *Vaccine* 31:5889–5896
- Hajdusek O, Almazan C, Loosova G, Villar M, Canales M et al (2010) Characterization of ferritin 2 for the control of tick infestations. *Vaccine* 28:2993–2998
- Galay RL, Miyata T, Umemiya-Shirafuji R, Maeda H, Kusakisako K et al (2014) Evaluation and comparison of the potential of two ferritins as anti-tick vaccines against *Haemaphysalis longicornis*. *Parasit Vectors* 7:482
- Vincentelli R, Romier C (2013) Expression in *Escherichia coli*: becoming faster and more complex. *Curr Opin Struct Biol* 23:326–334
- Assenberg R, Wan PT, Geise S, Mayr LM (2013) Advances in recombinant protein expression for use in pharmaceutical research. *Curr Opin Struct Biol* 23:393–402
- Young CL, Britton ZT, Robinson AS (2012) Recombinant protein expression and purification: a comprehensive review of affinity tags and microbial applications. *Biotechnol J* 7:620–634
- Cunha RC, Andreotti R, Garcia MV, Aguirre ADR, Leitao A (2013) Calculation of the efficacy of vaccines against tick infestations on cattle. *Rev Bras Parasitol Vet* 22:571–578
- Anisuzzaman IMK, Alim MA, Miyoshi T, Hatta T et al (2012) Longistatin is an unconventional serine protease and induces protective immunity against tick infestation. *Mol Biochem Parasitol* 182:45–53

Chapter 19

Vaccinomics Approach to Tick Vaccine Development

Marinela Contreras, Margarita Villar, Pilar Alberdi, and José de la Fuente

1 Introduction

Ticks are blood-feeding arthropod ectoparasites that transmit disease causing pathogens to humans and animals worldwide [1–3]. Tick–host–pathogen interactions have evolved through dynamic processes involving genetic traits of hosts, pathogens and ticks that mediate their development and survival [2–4]. In the early 1990s, a cost-effective alternative for cattle tick (*Rhipicephalus microplus* and *R. annulatus*) control became commercially available with BM86-based tick antigen vaccines reducing the use of acaricides and the problems associated with them such as selection of acaricide-resistant ticks and the contamination of the environment and animal products with pesticide residues [5]. However, new vaccines are needed for efficient control of vector infestations and pathogen infection and transmission [6]. Vaccinomics is based on the integration of “omics” technologies such as immunogenomics, transcriptomics, and proteomics with systems biology and bioinformatics for the development of next-generation vaccines [7]. As described here, the integration of various omics technologies towards discovering candidate tick protective antigens is important for development of next-generation tick vaccines. As a model we used the deer tick, *Ixodes scapularis*, and the transmitted pathogenic rickettsia, *Anaplasma phagocytophilum*, the causative agent of human, canine, and equine granulocytic anaplasmosis and tick-borne fever of ruminants.

2 Materials

All reagents used for buffer preparations need to be of analytical grade. The solutions are prepared with ultrapure water and stored at 4 °C, except for the solutions containing SDS that are stored at

20 °C to avoid detergent precipitation. Reagents for protein digestions and mass spectrometry analysis need to be of liquid chromatography–mass spectrometry (LC-MS) grade.

2.1 Tick Samples

Ticks are collected after feeding on vertebrate hosts, including both domestic and wild animals. After repletion, ticks are processed 1–3 h after collection. In some cases, ticks could be stored at –20 °C or in 70 % ethanol at 4 °C until processed (*see Note 1*).

I. scapularis ticks are obtained from laboratory colonies. Larvae and nymphs are fed on rabbits and adults are fed on sheep. Off-host ticks are maintained in a 12 h light: 12 h dark photoperiod at 22–25 °C and 95 % relative humidity. Ticks are infected with *A. phagocytophilum* by feeding on a sheep inoculated intravenously with *A. phagocytophilum* (human NY18 isolate)-infected HL-60 cells [8]. Ticks ($N=100–500$) are removed from the sheep 7 days after infestation, held in the humidity chamber for 4 days and dissected for DNA, RNA and protein extraction from whole internal tissues (nymphs) or midguts and salivary glands (adult females). Uninfected ticks are prepared in a similar way but feeding on an uninfected sheep. For analysis of biological replicates, two independent samples are collected and processed for each tick developmental stage and tissue. These experiments are conducted with the approval and supervision of the Institutional Animal Care and Use Committee.

2.2 Cultured Tick Cells and Anaplasma Phagocytophilum

The *I. scapularis* embryo-derived cell line ISE6 (provided by U. G. Munderloh, University of Minnesota, USA) is maintained in L-15B300 medium. The cells are cultured in sealed containers in ambient air at 31 °C, medium is changed once a week. The *I. scapularis* ISE6 tick cells are inoculated with the *A. phagocytophilum* human isolate NY18 purified from infected HL-60 cells. For purification of *A. phagocytophilum*, infected cells (late infection, 90 % infected cells) are harvested by pipetting and centrifuged at $200\times g$ for 5 min at room temperature. The cell pellet is resuspended in complete L-15B300 medium and, using a syringe, the cell suspension is mechanically disrupted five to ten times through a 26-gauge needle. After centrifugation at $1500\times g$ for 5 min, the supernatant is collected and used for inoculation of ISE6 cells. Uninfected cells are cultured in the same way, except with the addition of uninfected culture medium.

2.3 Reagents, Consumables, Kits, Equipment, and Software

These materials and their origin and use are described in the Subheading 3.

2.4 Buffers

1. Buffer for solubilization of proteins: 50 mM Tris–HCl pH 8.5, 4 % SDS, and 10 mM DTT. Mix 0.303 g of Tris, 2 g of SDS, and 0.077 g of DTT (dithiothreitol), add water to a volume of 25 ml, adjust to pH 8.5 with HCl, and bring up the volume to 50 ml with water.

2. UA buffer: 8 M urea in 0.1 M Tris-HCl (pH 8.5). Mix 24.024 g of urea and 0.606 g of Tris, add water to a volume of 25 ml, adjust to pH 8.5 with HCl, and bring up the volume to 50 ml with water.
3. 50 mM iodoacetamide in UA buffer: Add 0.009 g of iodoacetamide to 1 ml of UA buffer and mix with vortex until complete solubilization. This buffer should be prepared fresh prior to digestion and stored in the dark.
4. 50 mM ammonium bicarbonate, pH 8.8: Add 0.04 g of ammonium bicarbonate to 9 ml of LC-MS grade water, mix and adjust pH to 8.8 with 5 N ammonium hydroxide. Complete to 10 ml with water to obtain a 50 mM final solution.
5. 0.5 M sodium chloride: Add 2.922 g of sodium chloride to 75 ml of water, mix until complete solubilization, and bring up the volume to 100 ml with water.
6. 10 mM phosphate buffered saline (PBS), pH 7.4. Weigh 0.26 g KH_2PO_4 , 2.17 g $\text{Na}_2\text{HPO}_4 \cdot 7\text{H}_2\text{O}$, 8.71 g NaCl and add water to a volume of 1000 ml adjust to pH 7.4 with NaOH.
7. Lysis buffer. 50 mM potassium phosphate, pH 7.8, 400 mM NaCl, 100 mM KCl, 7 M urea, 10 mM imidazole. Prepare 1 M stock solutions KH_2PO_4 and K_2HPO_4 . Mix 0.3 ml KH_2PO_4 , 4.7 ml K_2HPO_4 , 2.3 g NaCl, 0.75 g KCl, and 68 mg imidazole, adjust pH to 7.8 with HCl.
8. Elution buffer. 50 mM potassium phosphate, pH 7.8, 400 mM NaCl, 100 mM KCl, 7 M urea, 500 mM imidazole. Prepare 1 M stock solutions KH_2PO_4 and K_2HPO_4 . Mix 0.3 ml KH_2PO_4 , 4.7 ml K_2HPO_4 , 2.3 g NaCl, 0.75 g KCl, and 3.4 g imidazole, adjust pH to 7.8 with HCl.

3 Methods

3.1 General Considerations

Different methodological approaches could be applied to the generation of transcriptomics and proteomics data. However, these methodologies have been optimized for tick samples and are thus described here [9–11].

3.2 Extraction of Tick Samples

1. Dissect ticks in PBS and wash adult midguts and salivary glands in PBS after collection to remove hemolymph-related cells.
2. Extract total RNA, DNA, and proteins from uninfected and infected tick samples using the AllPrep DNA/RNA/Protein Mini Kit (Qiagen, Valencia, CA, USA) and store them at $-20\text{ }^\circ\text{C}$ until used.

3.3 RNA Sequencing

1. Evaluate total RNA quality using the Agilent 2100 Bioanalyzer RNA Nano Chip (Agilent Technologies, Santa Clara, CA, USA).
2. Prepare samples for RNA sequencing using the TruSeq Stranded mRNA Sample Prep Kit (Illumina, San Diego, CA, USA) according to the manufacturer's protocol.
3. Perform size selection using a 2 % agarose gel to produce cDNA libraries ranging in size from 200 to 500 bp.
4. Enrich the libraries with 15 cycles of PCR and purify them using the QIAquick PCR purification kit (Qiagen, Valencia, CA, USA).
5. Run the enriched libraries on one Illumina HiSeq 2000 lane using 100 bp sequencing (CD BioSciences, Shirley, NY, USA). In the case of paired-end reads, distinct adaptors from Illumina are ligated to each end with PCR primers that allow reading of each end as separate runs. The sequencing reaction is run for 100 cycles. For paired-end reads, data are collected as two sets of matched 100-bp reads.
6. Separate reads for each of the indexed samples using a custom Perl script. Image analysis and base calling are done using the Illumina GA Pipeline software.

3.4 Bioinformatics for the Analysis of RNA Sequencing Data

1. Use TopHat [12] that incorporates the Bowtie algorithm to perform the alignment [13] to align the sequencing reads to the *I. scapularis* reference genome (assembly JCVI_ISG_i3_1.0; http://www.ncbi.nlm.nih.gov/nuccore/NZ_ABJB000000000) (*see Note 2*).
2. Estimate the raw counts per gene by the Python script HTSeq count [<http://www-huber.embl.de/users/anders/HTSeq/>] using the reference genome.
3. Use the raw counts per gene to estimate differential expression at $P < 0.05$ using DEGseq [14].

3.5 Proteomics

1. Dissolve the protein pellet obtained as described in Subheading 3.2, **step 2** in buffer for solubilization of proteins, boil for 10 min, and centrifuge at 12,000 × *g* for 10 min at room temperature. Discard the pellet and quantify the protein content in the supernatant with the Direct Detect system (Millipore, Billerica, MA, USA).
2. Precipitate 150 µg of protein extract to be analyzed by adding four volumes of ice-cold acetone to one volume of sample. Vortex the mixture, incubate at -20 °C for at least 4 h, and centrifuge at 12,000 × *g* for 15 min at 4 °C. Discard the supernatant and air-dry the pellet.

3. Digest proteins by the filter aided sample preparation (FASP) protocol (*see Note 3*). For that, dissolve the protein pellet in 200 μl of UA buffer and load onto 30 kDa centrifugal filter devices (FASP Protein Digestion Kit, Expedeon, TN, USA). Centrifuge at $14,000 \times g$ for 30 min and discard the flow-through from the collection tube.
4. Alkylate proteins adding 100 μl of 50 mM iodoacetamide in UA buffer and incubate for 20 min in the dark, Remove the excess of alkylation reagents washing three times with 100 μl UA and three additional times with 100 μl of 50 mM ammonium bicarbonate, pH 8.8.
5. Add 75 μl of modified trypsin (Promega, Madison, WI, USA) dissolved in 50 mM ammonium bicarbonate, pH 8.8 at 40:1 protein–trypsin (w/w) ratio. Incubate overnight at 37 °C for protein digestion wrapping the tops of the tubes with Parafilm to minimize the effects from evaporation.
6. Elute the resulting peptides by centrifugation with 50 μl of 50 mM ammonium bicarbonate, pH 8.8 (twice) followed by 50 μl 0.5 M sodium chloride, centrifuging the Spin Filter at $14,000 \times g$ for 10 min after each addition.
7. Add trifluoroacetic acid (TFA) to a final concentration of 1 % to stop the digestion and desalt the peptides using C18 Oasis-HLB cartridges (Waters, Milford, MA, USA) following the manufacturer instructions. Vacuum-dry and store at -20 °C until the mass spectrometry analysis.
8. For stable isobaric labeling, dissolve the resulting tryptic peptides in triethylammonium bicarbonate (TEAB) buffer (Sigma-Aldrich) and label using the 4-plex iTRAQ Reagents Multiplex Kit (Applied Biosystems, Foster City, CA, USA) according to manufacturer's protocol (*see Note 4*). After labeling, combine the samples to be analyzed and desalt as described in **step 7**.
9. Resuspend the sample in 0.1 % formic acid, load into the LC-MS/MS system for on-line desalting onto C18 cartridges, and analyze by RP-LC-MS/MS using a C-18 reversed phase nano-column (75 μm I.D. \times 50 cm, 3 μm particle size, Acclaim PepMap 100 C18; Thermo Fisher Scientific, Waltham, MA, USA) in a continuous acetonitrile gradient consisting of 0–30 % B in 145 min, 30–43 % B in 5 min and 43–90 % B in 1 min (solvent A=0.5 % formic acid; solvent B=90 % acetonitrile, 0.5 % formic acid). A flow rate of ca. 300 nl/min is used to elute peptides from the reverse phase nano-column to an emitter nanospray needle for real time ionization and peptide fragmentation on an orbital ion trap mass spectrometer (Orbitrap Elite, Thermo Fisher Scientific).

3.6 Bioinformatics for the Analysis of Proteomics Data

Peptide identification from raw data is carried out using the SEQUEST algorithm (Proteome Discoverer 1.4, Thermo Scientific).

1. Database search is performed against a compiled database containing all sequences from Ixodida (77,177 Uniprot entries in February 2015) and Anaplasmataceae (64,633 entries in February 2015) (<http://www.uniprot.org>) for identification of tick and pathogen proteins.
2. The following constraints may be used for the searches: tryptic cleavage after Arg and Lys, up to two missed cleavage sites, and tolerances of 600 ppm for precursor ions and 1200 mmu for MS/MS fragment ions and the searches were performed allowing optional Met oxidation and Cys carbamidomethylation. For iTRAQ labeled peptides, N-terminal and Lys iTRAQ modification is added as a fixed modification.
3. Peptide identification is validated using the probability ratio method [15] and false discovery rate (FDR) was calculated using inverted databases and the refined method [16] with an additional filtering for precursor mass tolerance of 12 ppm. Only peptides with a confidence of at least 95 % were used to quantify the relative abundance of each peptide.
4. Protein quantification from reporter ion intensities and statistical analysis of quantitative data is performed using QuiXoT [17].
5. Significant protein-abundance changes to estimate differential expression is obtained from the z values (standardized variable used by the method that expresses the quantitative values in units of standard deviation) at $P < 0.05$, using two replicates per sample.

3.7 Selection of Candidate Tick Protective Antigens

New candidate protective antigens will most likely be identified by focusing on abundant proteins with relevant biological function in tick feeding, reproduction, development, immune response, subversion of host immunity, and pathogen transmission. Tick antigens studied thus far have demonstrated multiple impacts when used in a vaccine including reductions in (a) tick infestations and fertility, (b) tick pathogen infection, (c) tick vector capacity for pathogen transmission, and (d) tick response to pathogen infection. Consequently, several criteria could be used for the selection of candidate tick protective antigens.

1. Select tick gene/protein fulfilling at least two of the following criteria (Fig. 1):
 - (a) Highly differentially regulated gene in at least two samples.
 - (b) Highly differentially represented protein.
 - (c) Genes/proteins with a relevant putative biological function in tick–pathogen interactions.
 - (d) Secreted or membrane-exposed protein.

Candidate tick protective antigen: ISCW024295 (Q4PMZ6) - Putative secreted protein

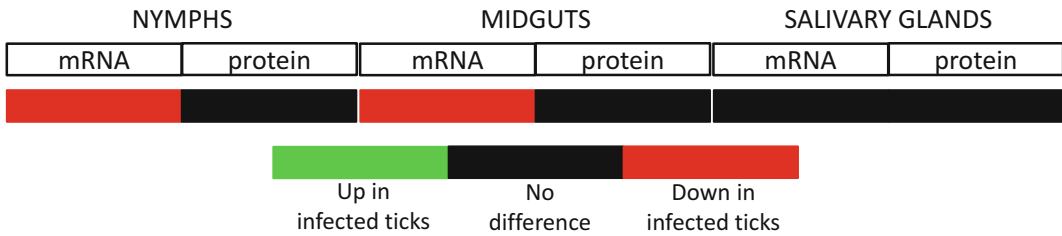

Fig. 1 Selection of candidate tick-protective antigens. Example of a candidate tick-protective antigen selected after transcriptomics and proteomics analysis of *I. scapularis*-*A. phagocytophilum* interactions and fulfilling the selection criteria of being highly differentially regulated gene in at least two samples and secreted or membrane-exposed protein

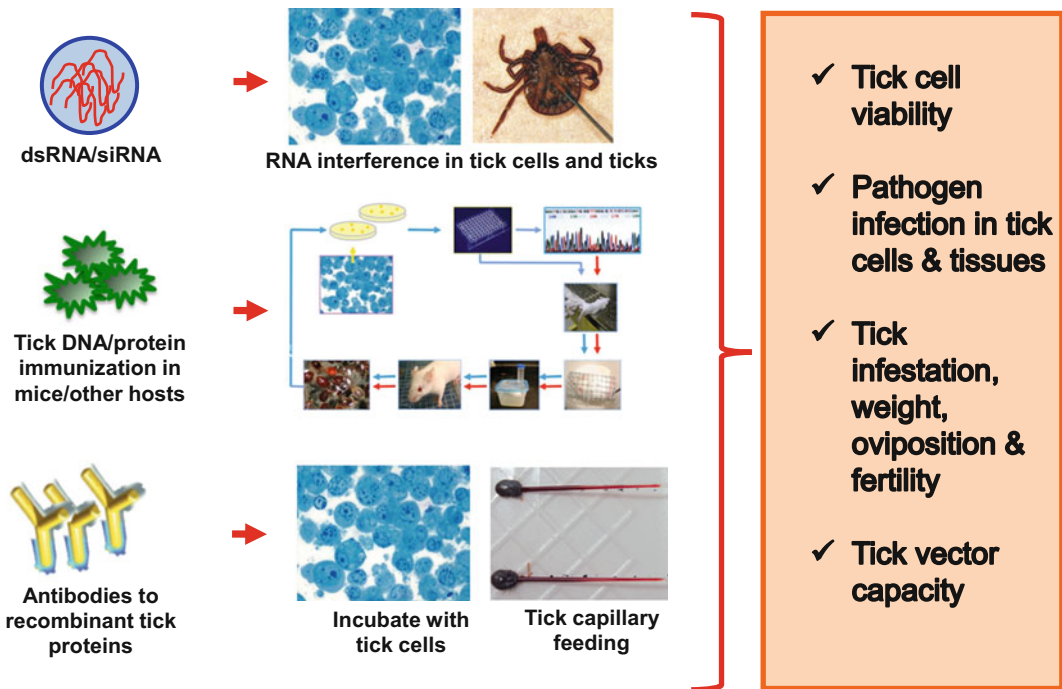

Fig. 2 Screening for candidate tick-protective antigens. Representation of different methodologies used for the screenings and characterization of tick-protective antigens

3.8 Screening of Candidate Tick-Protective Antigens

The screening of candidate tick-protective antigens is one of the limiting steps in the vaccinomics pipeline [7]. Several methodologies have been used to reduce the number of candidate tick-protective antigens that could be tested in vaccination trials [7]. These methodologies include, but are not limited to, RNA interference (RNAi) in cultured tick cells and ticks, DNA and protein immunization, in vitro tick feeding with anti-tick protein antibodies, and incubation of tick cells with anti-tick protein antibodies (Fig. 2). A combination of some of these methodologies may become the most effective platform for the screening and characterization of candidate tick-protective antigens.

Table 1
Oligonucleotide primers used for dsRNA synthesis, real-time PCR, and RT-PCR

Gene	GenBank accession no.	Forward and reverse primers (5'–3')	PCR conditions
<i>Ap 16S rRNA</i>	CP006617	CAGAGTTTGATCCTGGCTCAGAACG GAGTTTGCCGGGACTTCTTCTGTA	55 °C/30 s
<i>Is 16S rDNA</i>	ABJB010000000	GACAAGAAGACCCTA ATCCAACATCGAGGT	55 °C/30 s
<i>Ap msp4</i>	JQ522935	ATGAATTACAGAGAATTGCTTGTAGG TTAATTGAAAGCAAATCTTGCTCCTATG	60 °C/30 s
<i>Is rps4</i>	DQ066214	GGTGAAGAAGATTGTCAAGCAGAG TGAAGCCAGCAGGGTAGTTTG	60 °C/30 s
<i>Is cyclophilin</i>	ISCW008497	GCTTCGGTTACAAGGGCAGCAGCATT TCGGGTGTGCTTCAGGATGAAGTT	60 °C/30 s
<i>Is secreted protein</i>	ISCW024295	CACCATGCCGAAACAAGGCGAAAC TCCAGAGTCACCACACAAAACG	60 °C/30 s

Ap *A. phagocytophilum*, *Is* *I. scapularis*

3.8.1 Production of Tick Recombinant Proteins in *Escherichia coli*

1. Amplify the coding sequence for the *I. scapularis* protein (GenBank accession no. ISCW024295) by RT-PCR using total RNA from *I. scapularis* with specific primers and amplification conditions (Table 1).
2. Purify and quantify PCR products using the GenClean III kit (MP Biomedicals, Solon, OH, USA).
3. Clone into the expression vector pET101/D-TOPO (Invitrogen, Carlsbad, CA, USA) and transform into *E. coli* strain BL21 (Invitrogen, Carlsbad, CA, USA). Inoculate cells into Luria–Bertani (LB) broth containing 50 µg/ml ampicillin and 0.5 % glucose. Grow cultures at 37 °C to an OD_{600 nm} = 0.8 and add Isopropyl-β-d-thiogalactopyranoside (IPTG) to a final concentration of 0.5 mM, then incubate for 4 h to induce the production of recombinant proteins.
4. Harvest the bacteria and lyse in lysis buffer, containing protease inhibitors (Roche, San Cugat del Vallés, Barcelona, Spain).
5. Disrupt *E. coli* cells with a cell sonicator (Model MS73; Bandelin Sonopuls, Berlin, Germany). Sonicate for 10 min at 20 kHz; fix the acoustic power to 70 kW.
6. Separate insoluble protein fraction containing the recombinant protein as inclusion bodies by centrifugation at 15,000×g for 15 min at 4 °C and filter the supernatant (0.22 µm, Millipore, Billerica, MA, USA).

7. Purify the lysate by Ni affinity chromatography using 1 ml HisTrap FF columns mounted on AKTA-FPLC system (GE Healthcare, Piscataway, NJ, USA) and elute using elution buffer.
8. Refold the proteins by dialysis against 100 volumes of 10 mM PBS for 12 h at 4 °C.
9. Determine protein concentration using bicinchoninic acid (Pierce™ BCA Protein Assay Kit, Thermo Scientific, Rockford, IL, USA).
10. Analyze purified proteins by SDS-PAGE according to standard procedures.

3.8.2 Rabbit Immunization with Tick Recombinant Proteins

1. Mix the recombinant proteins in PBS with anhydromannitol-theroctadecenoate (Montanide ISA 50 V; Seppic, Paris, France) 1:1 batch-by-batch processes using two syringes connected to a T-connector (Braun Discofix-3, B. Braun Melsungen AG, Germany) to a final protein concentration of 250 µg/ml, then fill manually 2 ml glass bottles (Wheaton, Millville, NJ, USA) under sterile conditions.
2. Inject two rabbits/group subcutaneously with three doses (weeks 0, 3, and 6) containing 50 µg/0.2 ml dose of purified recombinant protein formulated as described above.
3. Collect blood samples from each rabbit before injection and 2 weeks after the last immunization to prepare preimmune and immune sera, respectively.
4. Purify IgGs from serum samples using the Montage Antibody purification kit and spin columns with PROSEP-A Media (Millipore, MA, USA) following the manufacturer's recommendations.

3.8.3 Analysis of Tick Cell Viability after Incubation with Anti- tick Protein Antibodies

1. Seed ISE6 tick cells 24 h before the assay at a density of approximately $5-7 \times 10^5$ cells/well, use three replicates per treatment.
2. Include control wells with (a) inoculum incubated with pre-immune IgG, (b) inoculum incubated with medium only, and (c) uninfected tick cells.
3. Purify *A. phagocytophilum* as previously described in Subheading 2.2.
4. Mix rabbit IgGs at a concentration of 2.2–2.4 mg/ml with the semi-purified bacterial inoculum (1:1) from **step 3.8.2** for 60 min at room temperature.
5. Add 100 µl of the inoculum plus IgG mix to each well and incubate at 34 °C for 30 min.
6. Remove the inoculum-IgG mix and wash the cells three times with PBS.

7. Add 1 ml complete medium to each well and incubate at 34 °C for 7 days.
8. Harvest cells, resuspend in PBS, and proceed to determine the effect of anti-tick protein antibodies on tick cell viability using the Apoptosis Detection kit (Immunostep, Salamanca, Spain).
9. Wash cells harvested in **previous step** twice with PBS, resuspend in 100 µl of 1× Annexin V-binding buffer.
10. Incubate cells simultaneously with 5 µl Annexin V (FITC labeled) and 5 µl of the non-vital dye propidium iodide (PI) for 15 min at room temperature in the dark.
11. Add 400 µl of 1× Annexin binding buffer and analyze by flow cytometry within 1 h.
12. Gate the viable cell population according to forward-scatter and side-scatter parameters.
13. Determine the percentage of live, apoptotic, necrotic, and dead cells by FACS. Intact cells will be Annexin V-FITC negative, PI negative, whereas early apoptotic cells will appear as Annexin V-FITC positive, PI negative. Necrotic cells will be positive for both while dead cells will be Annexin V-FITC negative, PI positive.

3.8.4 RNAi in Cultured Tick Cells

1. Synthesize siRNAs homologous to *I. scapularis* genes encoding for candidate tick-protective antigens using GE Healthcare (Piscataway, NJ, USA) <http://dharmacon.gelifsciences.com/>. An unrelated gene (i.e., *Rs86*; ref. [11]) is used as negative control.
2. Conduct RNAi experiments for gene knockdown in cell cultures by incubating tick cells with 10 µl dsRNA (5×10^{10} to 5×10^{11} mol/µl) and 90 µl L-15B medium in 24-well plates, using four wells per treatment. Control cells are incubated with the unrelated *Rs86* dsRNA.
3. After 48 h of dsRNA exposure, tick cells are infected with cell-free *A. phagocytophilum* human NY18 isolate or mock infected by adding culture medium alone.
4. Incubate tick cells for 72 h and collect for DNA and RNA extraction using TriReagent (Sigma, St. Louis, MO, USA) following manufacturer's recommendations.
5. Determine gene knockdown by real-time RT-PCR with gene specific primers (Table 1) using the iScript One-Step RT-PCR Kit with SYBR Green and the iQ5 thermal cycler (Bio-Rad, Hercules, CA, USA) following manufacturer's recommendations. A dissociation curve is run at the end of the reaction to ensure that only one amplicon is formed and that the amplicons denatured consistently in the same temperature range for

every sample. The mRNA levels are normalized against *ribosomal protein S4 (rps4)* and *cyclophilin* using the genNorm method (ddCT method as implemented by Bio-Rad iQ5 Standard Edition, Version 2.0). The results are compared between samples by Student's *t*-test with unequal variance ($P=0.05$; $N=3$).

6. Determine tick cell viability as described above.
7. Determine *A. phagocytophilum* DNA levels by major surface protein 4 (*mSP4*) real-time PCR normalizing against tick *16S rDNA* (Table 1) with PCR conditions of 5 min at 95 °C and 35 cycles of 15 s at 95 °C, 30 s at 60 °C, and 30 s at 72 °C.

4 Notes

1. When working with ticks collected in nature and on vaccine trials under field conditions, collected ticks are generally stored in ethanol and not deep-frozen because it is easier under field conditions and makes their shipment from one lab to another cheaper. Processing of these samples has been previously described [9]. However, samples could also be processed 1–3 h after collection when working on experimental tick infestations, which are the main approach used in vaccinomics.
2. The only genome available for ticks is that of *I. scapularis*, which allows aligning reads to this reference genome. However, for the other ticks species, de novo sequencing and assembly of mRNA is needed following a different pipeline [10, 18].
3. There are other digestion methods that could be also used but the Filter-Aided Sample Prep (FASP) is a technology that allows a complete protein solubilization and complete trypsin digestion in a fast way from any biological material. The resulting filtrate is free of detergents, large molecules, and other substances that would interfere with mass spectrometry analysis of proteomes [19].
4. iTRAQ labeling is a robust approach to absolute quantification of complex proteomes, but there are also other proteomics approaches that could be used depending on the necessities of the research (*see* Ref. [20], for a recent revision of quantitative proteomics in the field of microbiology).

Acknowledgements

This research was supported by grants BFU2011-23896 and the EU FP7 ANTIGONE project number 278976.

References

1. de la Fuente J, Estrada-Peña A, Venzal JM et al (2008) Overview: ticks as vectors of pathogens that cause disease in humans and animals. *Front Biosci* 13:6938–6946
2. Villar M, Popara M, Bonzón-Kulichenko E et al (2012) Characterization of the tick-pathogen interface by quantitative proteomics. *Ticks Tick-Borne Dis* 3:154–158
3. de la Fuente J, Kocan KM, Blouin EF et al (2010) Functional genomics and evolution of tick-Anaplasma interactions and vaccine development. *Vet Parasitol* 167:175–186
4. Galindo RC, de la Fuente J (2012) Transcriptomics Data integration reveals Jak-STAT as a common pathway affected by pathogenic intracellular bacteria in natural reservoir hosts. *J Proteomics Bioinform* 5:108–115
5. de la Fuente J, Almazán C, Canales M et al (2007) A ten-year review of commercial vaccine performance for control of tick infestations on cattle. *Anim Health Res Rev* 8:23–28
6. de la Fuente J (2012) Vaccines for vector control: exciting possibilities for the future. *Vet J* 194:139–140
7. de la Fuente J, Merino O (2013) Vaccinomics, the new road to tick vaccines. *Vaccine* 31:5923–5929
8. Kocan KM, Busby AT, Allison RW, Breshears MA, Coburn L et al (2012) Sheep experimentally-infected with a human isolate of *Anaplasma phagocytophilum* serve as a host for infection of *Ixodes scapularis*. *Ticks Tick-Borne Dis* 3:147–153
9. Popara M, Villar M, de la Fuente J (2015) Proteomics characterization of tick-host-pathogen interactions. *Methods Mol Biol* 1247:513–527
10. Villar M, Popara M, Ayllón N, Fernández de Mera IG, Mateos-Hernández L et al (2014) A systems biology approach to the characterization of stress response in *Dermacentor reticulatus* tick unfed larvae. *PLoS One* 9, e89564
11. Ayllón N, Villar V, Galindo RC, Kocan KM, Šima R, López JA et al (2015) Systems biology of tissue-specific response to *Anaplasma phagocytophilum* reveals differentiated apoptosis in the tick vector *Ixodes scapularis*. *PLoS Genet* 11(3), e1005120
12. Trapnell C, Pachter L, Salzberg SL (2009) TopHat: discovering splice junctions with RNA-Seq. *Bioinformatics* 25:1105–1111
13. Langmead B, Trapnell C, Pop M, Salzberg SL (2009) Ultrafast and memory-efficient alignment of short DNA sequences to the human genome. *Genome Biol* 10:R25
14. Wang L, Feng Z, Wang X, Wang X, Zhang X (2010) DEGseq: an R package for identifying differentially expressed genes from RNA-seq data. *Bioinformatics* 26:136–138
15. Martínez-Bartolomé S, Navarro P, Martín-Maroto F, López-Ferrer D et al (2008) Properties of average score distributions of SEQUEST: the probability ratio method. *Mol Cell Proteomics* 7:1135–1145
16. Navarro P, Vázquez J (2009) A refined method to calculate false discovery rates for peptide identification using decoy databases. *J Proteome Res* 8:1792–1796
17. Navarro P, Trevisan-Herraz M, Bonzon-Kulichenko E, Núñez E et al (2014) General Statistical framework for quantitative proteomics by stable isotope labeling. *J Proteome Res* 13:1234–1247
18. Genomic Resources Development Consortium, Contreras M, de la Fuente J, Estrada-Peña A, Grubhoffer L, Tobes R (2014) Genomic Resources Notes accepted 1 April 2014—31 May 2014. *Mol Ecol Resour* 14:1095, Transcriptome sequence divergence between Lyme disease tick vectors, *Ixodes scapularis* and *Ixodes ricinus*
19. Wisniewski J, Zougman A, Nagaraj N, Mann M (2009) Universal sample preparation method for proteome analysis. *Nat Methods* 6:359–362
20. Otto A, Becher D, Schmidt F (2014) Quantitative proteomics in the field of microbiology. *Proteomics* 14:547–565

Part V

Vaccine Adjuvants

Development of CpG ODN Based Vaccine Adjuvant Formulations

Mayda Gursel and Ihsan Gursel

1 Introduction

The innate immune system responds to the presence of pathogens by sensing “pathogen associated molecular patterns” (PAMPs) expressed by infectious microorganisms [1]. Pathogen-derived nucleic acids represent a critical group of PAMPs that are sensed by a plethora of nucleic acid sensing receptors expressed in immune cells [2]. This recognition initiates a robust innate immune response that enables the host to control the initial spread of infection and subsequently generate sterilizing adaptive immunity. One type of nucleic acid PAMP is the unmethylated CpG motifs present at high frequency in bacterial DNA (but rare in mammalian DNA due to CG suppression and CG methylation) [3]. Unmethylated CpG DNA is recognized by TLR9 expressed by B lymphocytes, dendritic cells (DC), and macrophages. Synthetic oligodeoxynucleotide (ODN) containing unmethylated CpG motifs duplicate the ability of bacterial DNA to stimulate the innate immune system via TLR9 [4].

The immune stimulatory effects of CpG ODNs variegate on the basis of their subcellular distribution, backbone modification, length, and formation of secondary and tertiary structures [5]. Based on their differential activation of immune cells, four major classes of synthetic CpG ODNs have been defined: (a) A or D-type CpG, (b) B or K-type CpG, (c) C-type CpG, and (d) P-type CpG ODNs (Reviewed in ref. 6). In general, K class ODNs are potent B cell activators and induce TNF- α secretion from plasmacytoid dendritic cells (pDC) but not interferon- α . In contrast, D-, C-, and P-class ODNs are capable of stimulating variable amounts of IFN α secretion from pDCs. Of the latter three ODN classes, D ODNs are the most potent IFN α inducers but have the drawback

of forming multimers, and random concatamers complicating their clinical grade manufacturing process. In fact, to date, only three clinical trials tested the vaccine adjuvant and/or immunotherapeutic activity of D class CpG ODN [7–9]. All three studies harnessed a stabilized version of this ODN class following packaging into virus like particles consisting of the bacteriophage Q β coat protein.

In this chapter, we describe two alternative methods of preparing CpG ODN-based vaccine adjuvant formulations that can induce a robust IFN α response from human peripheral blood mononuclear cells. Method 1 details a protocol to stabilize D-type CpG ODN in cationic liposomes. Labile bioagents are protected following liposome encapsulation [10]. This mild approach relies on the dehydration–rehydration technique, does not involve detergents or organic solvents and the encapsulation yield is much higher than most other widely accepted liposome generation methods [11–13].

Method 2 describes a simple strategy of anionic bioactive agent stabilization following complexation with cationic peptides [14–16]. Peptide-mediated multimerization of a K-type ODN devoid of IFN α stimulating activity into stable nuclease-resistant nanostructures (i.e., nanorings) with type I interferon inducing activity is only achieved through the use of a short and non-flexible ODN (K23) and the HIV-derived peptide Tat_(47–57) at a specific ODN–peptide molar ratio (1:16).

2 Materials

2.1 CpG ODN Sequences (Alpha DNA, Canada: Bases Shown in Capital Letters Are Phosphorothioate; Lower Case Letters Indicate Phosphodiester Backbone)

D35 (D-type ODN used in Method 1): GGtgcatcgatgcaggggGG
 D35 flip (Control D-ODN with no immunostimulatory activity): GGtgcatcgatgcaggggGG
 K23 (K-type ODN used in Method 2): TCGAGCGTTCTC
 K23 flip (Control K-ODN with no immunostimulatory activity): TCGAGGCTTCTC

2.2 Lipids Used in Liposome Preparation (Avanti Polar Lipids, Alabaster, AL)

Dimethylaminoethanecarbamol-cholesterol (DC-Chol), dioleoyl phosphatidylethanolamine (DOPE), and polyethylene glycol2000-phosphatidylethanolamine (PEG-PE).

2.3 Cationic Peptides (AnaSpec Inc., USA)

LL-37: LLGDFFRKSKEKIGKEFKRIVQRIKDFLRNLPRTES
 HIV-Tat_(47–57): YGRKKRRQRRR

2.4 CpG ODN Loaded Liposome Preparation (Method 1)

1. 50 ml round-bottom flask (Pyrex, vacuum resistant).
2. Rotary evaporator with a water bath attachment (Heidolph, Laborota, Germany, or any brand).
3. Argon cylinder tank (without O₂).
4. Cup Horn Vibra Cell Sonicator (Sonics and Materials, Danbury, CT, USA, or any brand).
5. Freeze-drier (Heto-Holten, Maxi-Dry Lyo, Denmark, or any brand).
6. LiposoFast extruder equipped with polycarbonate filters (Avestin, Ottawa, Canada).
7. Sterile glass vials (5 ml).

2.5 Demonstration of Complexation between CpG ODN and Cationic Peptides Using Agarose Gel Electrophoresis (Method 2)

1. Agarose, loading dye, O'GeneRuler 100 bp DNA Ladder (Thermo Scientific, USA), and nucleic acid stain suitable for gel electrophoresis.
2. Agarose gel electrophoresis: for 150 ml of 1.0 % agarose gel, use 1.5 g of ultrapure agarose (electrophoresis grade) with 150 ml of 1× TAE. Prepare 1 l of 10× TAE stock solution in ultrapure water with 48.4 g of Tris base, 3.72 g disodium EDTA, and adjust to pH 8.5 with glacial acetic acid. Include ethidium bromide (1 mg/ml) before pouring the gel.
3. Gel documentation system.

2.6 Assessment of Vaccine Adjuvant Formulations for Their IFN α Triggering Activities Using Human Peripheral Blood Mononuclear Cells (hPBMC)

1. Ficoll-Paque PLUS density gradient medium (GE Healthcare Biosciences, Sweden).
2. Centrifuge with swing bucket clinical rotor.
3. 96-well tissue culture plates.
4. RPMI-1640 cell culture medium containing 10 % FBS, 50 μ g/ml penicillin/streptomycin, 10 mM HEPES, 0.11 mg/ml Na pyruvate, 2 mM L-glutamine, 1× nonessential amino acids (from a 100× stock solution), and 0.05 mM 2-mercaptoethanol.

2.7 Cytokine Measurement from Culture Supernatants

1. Immulon 2B plates (Thermo LabSystems, USA).
2. Human IFN- α 2 ELISA development kit (ALP) from Mabtech, Sweden.
3. ELISA blocking buffer: Phosphate buffered saline (PBS; 10 mM phosphate buffer, pH 7.4, 150 mM NaCl) containing 5 % bovine serum albumin and 0.025 % Tween 20.
4. ELISA washing buffer: PBS containing 0.05 % Tween 20.
5. Detection antibody diluent: PBS containing 5 % FBS and 0.025 % Tween 20.
6. SIGMAFAST p-Nitrophenyl phosphate (p-Npp) substrate tablets.
7. 96-well multi-plate reader equipped with a 405 nm filter.

3 Methods

3.1 Preparation of Cationic Liposome Stabilized D-Type CpG ODN (See Scheme 1a, b)

1. Prepare lipid stocks in chloroform (10 mg/ml) and store under argon gas at -20°C until use.
2. For the preparation of 20 μmol cationic stealth liposomes, pipette lipids from corresponding lipid stocks at a 4:6:0.06 molar ratio (DC-Chol-DOPE-PEG-PE) into a 50 ml round bottom flask.
3. Complete the volume to 2.0 ml by adding chloroform and connect the flask to a rotary evaporator.
4. Set the evaporator rotation speed to maximum (the temperature of the water bath should be set to 37°C).
5. Evaporate the chloroform in the round bottom flask for 20 min.
6. Solvent-free thin lipid film should appear in the inner wall of the round bottom flask at the end of this process.
7. Remove the flask from the rotary evaporator and purge with argon for 30–60 s. Make sure all residual chloroform is removed from the flask and argon purging will remove residual oxygen remained in the flask (*see Note 1*).
8. Seal the round bottom flask with a glass cap and continue the following steps under laminar hood. Transfer 30–40 sterile glass beads (300 μm average size, from Sigma) into flask.
9. Add 1.0 ml sterile phosphate-buffered saline (PBS) onto beads, and shake the solution in a circular motion until lipid film disappears from the flask wall. This motion helps the lipid film to be removed by the abrasive force of the glass beads and leads to the generation of empty, large multilamellar liposomes.
10. Collect the resulting milky solution from the flask and transfer into a glass vial.
11. In order to generate small unilamellar vesicles (SUVs), sonicate the liposome solution five cycles (30 s/cycle) with an amplitude of 70 % and a second set of five cycles with an amplitude of 50 % on ice. Keep the vial on ice for 15 s in between sonication cycles to prevent excessive heating.
12. For a 20 μmol SUV liposome solution (1.0 ml in PBS) add 1 mg CpG ODN solution (1 mg/ml ODN solution) and mix gently by vortexing. Total volume is 2.0 ml at this stage.
13. Remove the vial cap and seal the vial mouth with a Parafilm. Using a syringe needle, punch 6–8 holes on the Parafilm. This will let air out during the lyophilization step.
14. Immediately freeze the liposome/ODN solution in liquid nitrogen for 1 min.

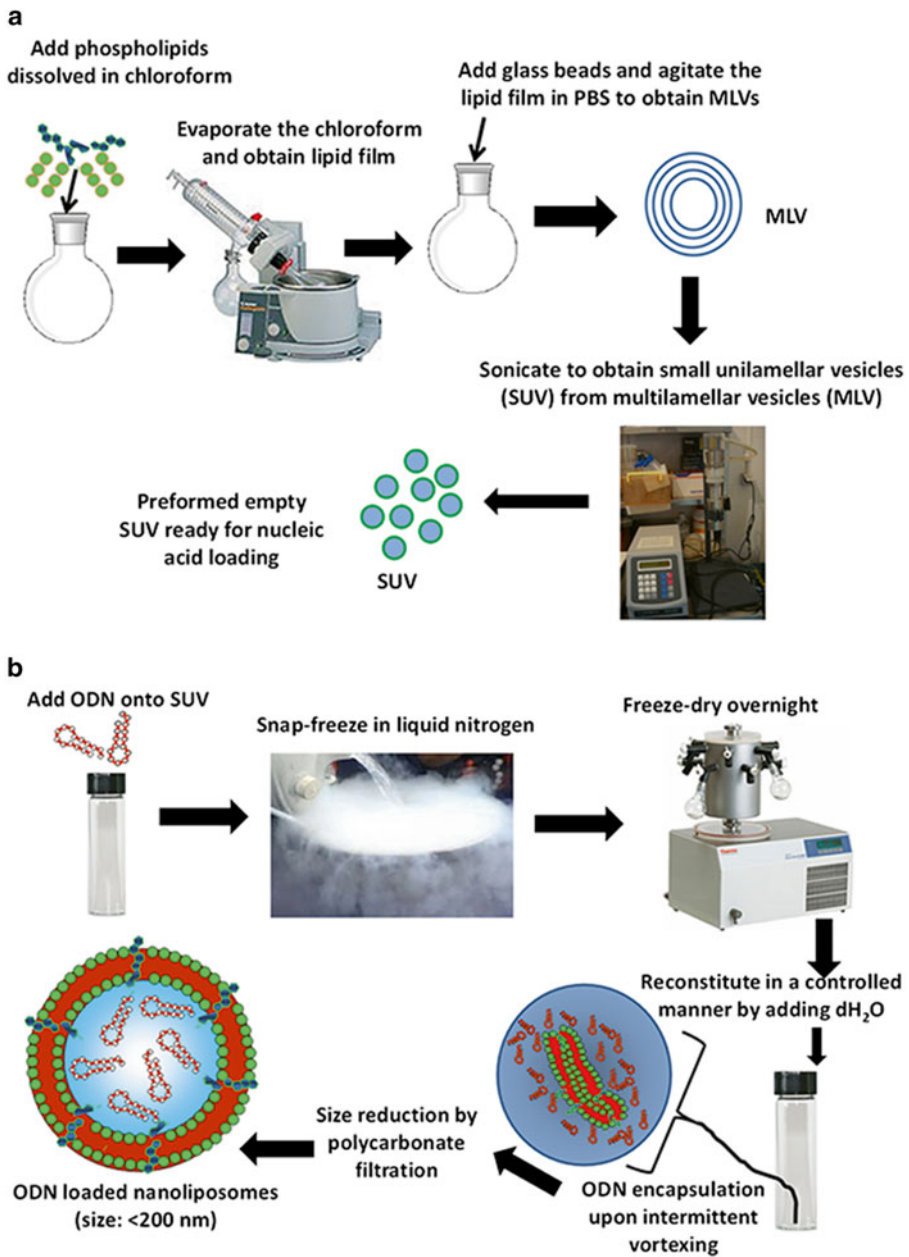

Scheme 1 Preparation of cationic liposome stabilized D-type CpG ODN. (a) Method for the preparation of preformed, unloaded small unilamellar vesicles. (b) Method to generate CpG ODN loaded liposomes

15. Place the frozen liposome/ODN mixture in a freeze-dryer and lyophilize overnight (*see Note 2*).
16. Remove the vial from the lyophilizer. At this stage there should be a white powder in the vial.
17. Add 1:10 volume of ddH₂O (200 μ l ddH₂O) on to the liposome powder and vortex vigorously for 15 s.
18. Continue vortexing for 15 s every 5 min for the total duration of 30 min. This will allow the ODN to dissolve in ddH₂O and diffuse into the liposome bilayer while liposomes are swelling in the aqueous environment.
19. Add 200 μ l PBS on to the liposome solution, gently vortex, and set aside for 10 min.
20. Complete the volume to 1.0 ml by adding 600 μ l PBS. This generates the CpG ODN loaded liposome stock.
21. To reduce the size of the loaded liposomes, assemble the LiposoFast extruder, and gently transfer the liposome solution into the glass syringe provided with the extruder. Filter ten times through the 1.0 μ m cut-off polycarbonate filter. Replace the filter with the 500 nm polycarbonate filter and filter 10 more times. Finally, replace 500 nm filter with the 200 nm filter and repeat 10 more filtrations.
22. Transfer the extruded nanoliposomes encapsulating the CpG ODN into a sterile vial.

3.1.1 Determination of ODN Encapsulation Efficiency

1. Remove 50 μ l of the liposome aliquot into a microcentrifuge tube.
2. Centrifuge for 1 h at 16,100 \times *g* in an Eppendorf centrifuge.
3. Gently collect the clear supernatant into a clean microcentrifuge tube.
4. Determine the non-encapsulated ODN concentration in the supernatant by recording the OD at 260 nm using NanoDrop[®] ND-100 (NanoDrop Technologies, USA).
5. Determine ODN encapsulation efficiency indirectly by subtracting the amount of non-encapsulated ODN from the original input amount and then divide it to the original input ODN amount that was initially mixed with empty SUVs before freeze-drying. Multiply by 100 (*see Note 3*).

3.2 Preparation and Testing of K-Type CpG ODN/Cationic Peptide Complexes (Method 2)

3.2.1 Preparation of CpG ODN/Cationic Peptide Complexes

1. Prepare stock solutions of CpG ODNs (K23 and K23 flip) in DNase-free ddH₂O (final concentration of 1 mg/ml).
2. Prepare stock solutions of cationic peptides in ddH₂O (final concentration of 5 mg/ml).
3. Mix the ODNs and peptides at different molar ratios (1:1, 1:2, 1:4, 1:8, 1:16) as detailed in Table 1 (*see Note 4*).
4. Incubate complexes for 30 min at RT and proceed to confirmation of complexation with agarose gel electrophoresis.

Table 1
Concentrations of K-type CpG ODN and cationic peptides required to form complexes of various molar ratios

Samples	Molar ratio	K23 (μM)	Peptide (μM)	K23 (μg)	Peptide (μg)	K23 (μl) stock 1 λ	Peptide (μl) stock 5 λ	H ₂ O (μl)
K23	–	80	–	19.2	–	19.2	–	40.8
K23/LL37	1:1	80	80	19.2	21.54	19.2	4.2	36.6
K23/LL37	1:2	80	160	19.2	43.14	19.2	8.4	32.4
K23/LL37	1:4	80	320	19.2	86.16	19.2	16.8	24
K23/LL37	1:8	80	640	19.2	172.2	19.2	34.2	6.6
K23/Tat	1:2	80	160	19.2	15	19.2	3	37.8
K23/Tat	1:4	80	320	19.2	30	19.2	6	34.8
K23/Tat	1:8	80	640	19.2	60	19.2	12	28.8
K23/Tat	1:16	80	1280	19.2	120	19.2	24	16.8

3.2.2 Demonstration of Complexation Using Agarose Gel Electrophoresis

1. To confirm that CpG ODN formed complexes with the cationic peptides, mix 20 μl of each complex (concentration based on ODN amount) with 4 μl of 6 \times loading dye and load the wells of a 1 % agarose gel containing 1 mg/ml ethidium bromide with the samples.
2. Apply uncomplexed CpG ODN (1.6 μg) to one well as the negative control.
3. Apply the 100–1000 bp range DNA ladder as a marker (3 μg /well).
4. Carry out agarose gel electrophoresis using 1 \times TAE buffer at 70 V for 60 min.
5. Visualize the gels under a UV transilluminator (*see Note 5*).

3.2.3 Testing of IFN α -Inducing Activity of Vaccine Adjuvant Formulations Using hPBMC

1. Collect blood samples (10 ml) from healthy donors into anti-coagulant containing (sodium citrate, EDTA, or heparin) tubes (Note that blood collection from healthy donors requires ethical approval).
2. Dilute to 20 ml with 1 \times PBS.
3. Pipette 10 ml of Ficoll-Paque PLUS density gradient medium into a 50 ml conical tube and carefully layer the diluted blood on top of the gradient medium without disturbing the layers.
4. Centrifuge samples at 400 $\times g$ for 30 min with the break off at room temperature.
5. Using a sterile pipette collect the cloudy PBMC layer that resides at the interphase of the uppermost plasma and the clear density gradient medium and transfer to a new tube.

6. Wash the cells two times using 50 ml RPMI medium and centrifugation at $400 \times g$ for 10 min.
7. Resuspend the resultant cell pellet in 1 ml of RPMI, count the cells using a hemocytometer and adjust the working cell concentration to 4×10^6 cells/ml.
8. For testing of the CpG ODN/cationic peptide complexes, stimulate cells in a 96-well tissue culture plate (400,000 cells/well) in a total volume of 200 μ l using three different doses (0.3, 1, and 3 μ M) of uncomplexed or complexed CpG ODNs and their flip controls for 24 h at 37 °C and 5 % CO₂ (*see Note 6*).
9. Collect culture supernatants at the end of this incubation period.

3.2.4 Cytokine ELISA

1. Coat a 96-well Immunol II plate using 50 μ l of anti-human coating antibody in PBS (5 μ g/ml).
2. Tap the plates to ensure uniform spreading and incubate at RT for 4 h or at 4 °C overnight.
3. Remove the coating solution by inverting the plates, add blocking buffer (200 μ l) and incubate at RT for 2 h.
4. Decant the blocker, wash plates with ELISA wash buffer five times (immerse plates into a container filled with wash buffer to fill all wells and incubate for 5 min before decanting).
5. Rinse plates with ddH₂O and dry wells by tapping over an absorbent tissue paper.
6. Distribute 50 μ l of supernatants and the provided cytokine standard in triplicate (250 ng/ml highest concentration; serially diluted twofold in PBS to make up a standard curve of 12 different concentrations) and incubate for 2–3 h at room temperature or overnight at 4 °C.
7. Wash plates as described above (**steps 4 and 5**).
8. Add 50 μ l of 1:1000 diluted (dilution in detection antibody diluent) biotinylated-secondary antibody solution into wells and incubate 2–3 h at room temperature or overnight at 4 °C.
9. Wash plates as described above (**steps 4 and 5**).
10. Distribute 50 μ l of 1:5000 diluted (dilution in detection antibody diluent) streptavidin-alkaline phosphatase solution to each well (*see Note 7*) and incubate 1 h at RT.
11. Wash plates as described above (**steps 4 and 5**).
12. To develop the plates, dissolve a p-Npp At in 4 ml ddH₂O and 1 ml p-Npp buffer and transfer 50 μ l of this solution to each well.
13. Follow color development at 405 nm over time using a 96-well multiplate reader until recombinant cytokine standards reach a four-parameter saturation and yield an S-shaped curve. Determine cytokine concentration of each sample using the standard curve (*see Note 8*).

4 Notes

1. This step is critical. Argon purging eliminates both residual chloroform and also replaces the oxygen present in the flask. O₂ gas facilitates lipid peroxidation, so it is vital to remove all oxygen in the flask via argon purging.
2. At this stage, there is no encapsulation of ODN within the liposome. The encapsulation will be achieved during the dehydration–rehydration step).
3. Expected encapsulation efficiency for the D ODN should be at least 80 % or higher. The activity of as such prepared liposomes can be tested as described in Subheading 3.2.2 prior to mixing with an antigen of choice for vaccination experiments.
4. Preparation of complexes in salt containing buffers compromises complexation efficiency. Final volume of the solution in which complexes are formed should not exceed 60 μ l. Table 1 details the optimal volumes and concentrations of reagents to be used for the most efficient complexation.
5. Expected results are demonstrated in Fig. 1.

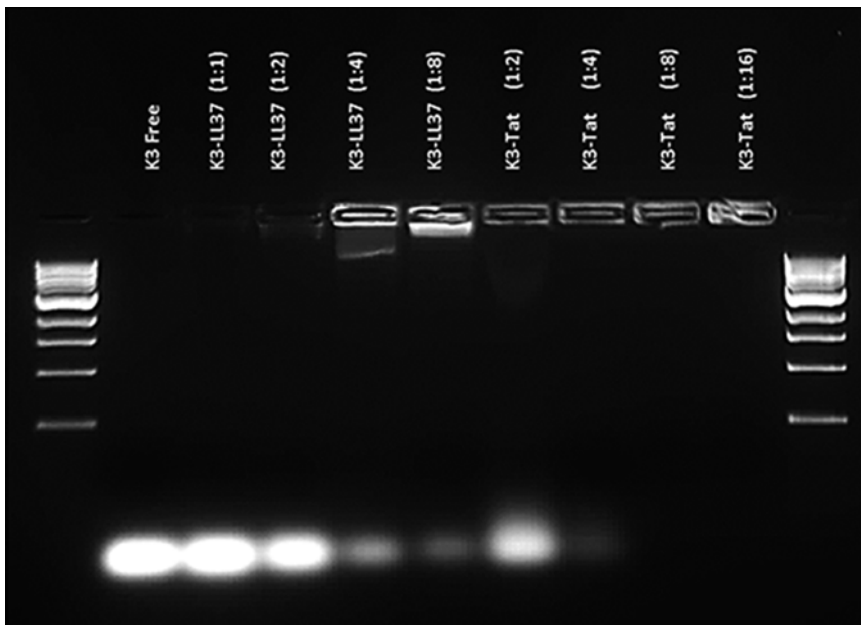

Fig. 1 A constant amount of K-ODN (80 μ M) was incubated with increasing amounts of cationic peptides for 30 min at room temperature in a final volume of 60 μ l ddH₂O. CpG ODN or its complexes (1.6 μ g/well) were subjected to agarose gel electrophoresis. Uncomplexed CpG ODN demonstrates a bright signal at the bottom of the gel whereas this signal disappears following successful complexation. DNA ladder with 100–1000 bp range was used as a marker (3 μ g/well)

6. For example, for the 3 μM final ODN concentration, mix 48.6 μl of formed complex with 275.4 μl RPMI medium and add 50 μl of this onto 150 μl cells.
7. The streptavidin-alkaline phosphatase solution must be prepared at least 2 h prior to its use to ensure uniform color development.
8. We found that K23:Tat (1:16; 1 μM) triggered an interferon-alpha response that was equivalent to levels obtained with 3 μM D ODN stimulation. LL-37-incorporating aggregates elicited a substantially lower response.

Acknowledgements

This work was supported by TÜBİTAK grants 113S207 to I.G, 113S305 and 111S151 to M.G.

References

1. Medzhitov R (2007) Recognition of microorganisms and activation of the immune response. *Nature* 449:819–826
2. Kumar H, Kawai T, Akira S (2011) Pathogen recognition by the innate immune system. *Int Rev Immunol* 30:16–34
3. Krieg AM, Yi AK, Matson S, Waldschmidt TJ, Bishop GA, Teasdale R, Koretzky GA, Klinman DM (1995) CpG motifs in bacterial DNA trigger direct B-cell activation. *Nature* 374:546–549
4. Klinman DM, Currie D, Gursel I, Verthelyi D (2004) Use of CpG oligodeoxynucleotides as immune adjuvants. *Immunol Rev* 199:201–216
5. Hanagata N (2012) Structure-dependent immunostimulatory effect of CpG oligodeoxynucleotides and their delivery system. *Int J Nanomedicine* 7:2181–2195
6. Bode C, Zhao G, Steinhagen F, Kinjo T, Klinman DM (2011) CpG DNA as a vaccine adjuvant. *Expert Rev Vaccines* 10:499–511
7. Senti G, Johansen P, Haug S, Bull C, Gottschaller C, Muller P, Pfister T, Maurer P, Bachmann MF, Graf N, Kündig TM (2009) Use of A-type CpG oligodeoxynucleotides as an adjuvant in allergen-specific immunotherapy in humans: a phase I/IIa clinical trial. *Clin Exp Allergy* 39:562–570
8. Klimek L, Willers J, Hammann-Haenni A, Pfaar O, Stocker H, Mueller P, Renner WA, Bachmann MF (2011) Assessment of clinical efficacy of CYT003-QbG10 in patients with allergic rhinoconjunctivitis: a phase IIb study. *Clin Exp Allergy* 41:1305–1312
9. Beeh KM, Kanniss F, Wagner F, Schilder C, Naudts I, Hammann-Haenni A, Willers J, Stocker H, Mueller P, Bachmann MF, Renner WA (2013) The novel TLR-9 agonist QbG10 shows clinical efficacy in persistent allergic asthma. *J Allergy Clin Immunol* 131:866–874
10. Gregoriadis G (2007) Liposome technology. Informa Healthcare, New York
11. Gregoriadis G, Gursel I, Gursel M, McCormack B (1996) Liposomes as immunological adjuvants and vaccine carriers. *J Control Release* 41:49–56
12. Gursel I, Gursel M, Ishii KJ, Klinman DM (2001) Sterically stabilized cationic liposomes improve the uptake and immunostimulatory activity of CpG oligonucleotides. *J Immunol* 167:3324–3328
13. Eriği E, Gursel M, Gursel I (2011) Differential immune activation following encapsulation of immunostimulatory CpG oligodeoxynucleotide in nanoliposomes. *Biomaterials* 32:1715–1723
14. Gungor B, Yagci FC, Tincer G, Bayyurt B, Alpdundar E, Yildiz S, Ozcan M, Gursel I, Gursel M (2014) CpG ODN nanorings induce IFN α from plasmacytoid dendritic cells and demonstrate potent vaccine adjuvant activity. *Sci Transl Med* 6:235ra61
15. Gungor B, Yagci FC, Gursel I, Gursel M (2014) Forging a potent vaccine adjuvant: CpG ODN/cationic peptide nanorings. *Oncoimmunology* 3, e950166
16. Yildiz S, Alpdundar E, Gungor B, Kahraman T, Bayyurt B, Gursel I, Gursel M (2015) Enhanced immunostimulatory activity of cyclic dinucleotides on mouse cells when complexed with a cell-penetrating peptide or combined with CpG. *Eur J Immunol* 45:1170–1179

Part VI

Vaccine Vectors and Production Systems

Chapter 21

Assembly and Assessment of DNA Scaffolded Vaccines

Xiaowei Liu, Lili Wang, Hao Yan, and Yung Chang

1 Introduction

Vaccination is one of the most cost-effective public health interventions. Due to its success in the conquest of many infectious diseases, vaccination has also been explored as a prevention and/or therapeutic strategy in dealing with many other diseases, including autoimmunity [1], cancer [2], and drug abuse [3]. Over the past three decades, recombinant DNA technology has significantly advanced the vaccine field, leading to safer recombinant microbes, DNA vaccines, and subunit vaccines. However, recombinant subunit vaccines usually lack sufficient efficacy. In recent years, the advancement in nanotechnology and the availability of various nanomaterials has made strides in improving the efficacy of the subunit vaccines [4]. Inspired by nature, synthetic microparticles and nanoparticles have been engineered to incorporate well-defined antigenic components and adjuvant molecules to form nanovaccines that can be rationally designed and tailored for enhanced immunogenicity and desired safety [4, 5]. Recently, DNA nanostructures have been recognized as an ideal structural material for the assembly of various biomolecules [6–12], including vaccines [13].

DNA nanotechnology makes good use of the simple Watson–Crick base pairing principle to provide a highly programmable and robust way to self-assemble diverse nanostructures [14]. Various two- and three-dimensional DNA nanostructures have been constructed [15–18], thereby providing a diverse “tool box,” and have been utilized for precise organization of biochemical molecules and targeted cellular transport [7, 10, 11]. DNA nanoscaffold provides control over structural features such as particle size and geometry, epitope valency and configuration, and has been recently explored as a synthetic platform for vaccine assembly, as well as assembly of other immunomodulating modules [8, 9, 13]. Here

we describe the assembly of DNA scaffolded vaccines, the structural stability of these vaccines, and the assessment of their immunogenicity.

2 Materials

2.1 Buffer Preparation

1. Stock (50× TAE) buffer: Mix the following components and add diH₂O (distilled and deionized water) to a total volume of 1000 mL: 242.2 g Tris base (Formula weight [FW] 121.1, final concentration 2 M); 57.2 mL acetic acid (FW 60.05, final concentration 1 M); 37.2 g ethylenediaminetetraacetic acid disodium salt dihydrate (EDTA·Na₂, FW 372.24, final concentration 0.1 M). Store at 4 °C.
2. Annealing (10× TAE/Mg²⁺) buffer: Weigh 26.8 g magnesium acetate tetrahydrate (FW 214.46, final concentration 125 mM), and mix with 200 mL stock (50× TAE) buffer. Add diH₂O to a final volume of 1000 mL. Adjust pH to 8.0, and filter through bottle top vacuum filter (500 mL, pore size 0.22 μm). Store the annealing buffer in 1 L sterile plastic bottles or as aliquots in 1.5 mL sterile tubes at 4 °C (*see Note 1*).
3. 0.5 M EDTA (pH 8.0): Weigh 186.1 g EDTA·Na₂ (final concentration 500 mM), and 24 g sodium hydroxide (NaOH, FW 40.00, final concentration 600 mM). Add diH₂O to a final volume of 1000 mL. Adjust pH to 8.0 and filter through bottle top vacuum filter.
4. 10× TBE buffer: Weigh 108 g Tris base (final concentration 0.89 M) and 55 g boric acid (FW 61.83, final concentration 0.89 M). Mix with 40 mL 0.5 M EDTA (pH 8.0) and add diH₂O to 1000 mL (*see Note 2*).
5. ELISA coating buffer: Weigh 6.06 g Tris base and 0.2 g sodium azide (NaN₃), dissolve in 1000 mL diH₂O. Adjust pH with 5 M sodium hydroxide (NaOH, FW 40.00) to 9.5. Filter through bottle top vacuum filter and store in 1 L glass bottle at room temperature.
6. ELISA blocking buffer: Add 100 mL 10× PBS to 800 mL diH₂O. Weigh 10 g bovine serum albumin (BSA) and 1 g NaN₃, mix with 500 μL Tween-20 and the above PBS diluents. Stir to dissolve, and add diH₂O to bring the volume to 1000 mL. Filter through bottle top vacuum filter and store in 1 L glass bottle at 4 °C.
7. ELISA washing buffer: Weigh 9 g sodium chloride (NaCl) and dissolve in water. Add 2.5 mL Tween 20 and diH₂O to a final volume of 1000 mL. Filter through bottle top vacuum filter and store in 1 L glass bottle at room temperature.

2.2 Denaturing PAGE Gel Components for Purification of DNA Oligos

The following DNA oligos are purchased from Integrated DNA Technologies:

Strand-L: 5' AGG CAC CAT CGT AGG TTT C TTG CCA GGC ACC ATC GTA GGT TTCT TGC CAG GCA CCA TCG TAG GTT T CTT GCC 3'

Strand-M-linker: 5' CAG AGG CGC TGC AAG CCT ACG ATG GAC ACG GTA ACG ACT 3'

Strand-CpG-linker: 5' AGC AAC CTG CCT GTT AGC GCC TCT GTT TTT T*C*C *A*T*G *A*C*G *T*T*C* C*T*G*A*C*G*T*T 3', where * stands for phosphorothioate backbone modification.

Strand-S: 5'/5Biosg/TTA CCG TGT GGT TGC TAG TCG TT 3', where/5Biosg/stands for 5' biotin modification.

Denaturing PAGE gels are used for oligo purification, and the following two gel mixes are prepared before gel preparation.

1. Twenty percent denature PAGE gel mix: Weigh 500 g urea (FW 60.06, final concentration 8.3 M), and mix with 500 mL 40 % acrylamide stock solution (19:1 Ac-Bis) and 100 mL 10× TBE buffer in a glass flask. Wrap the flask with aluminum foil and put it on a heated magnetic stirrer with temperature adjusted to 30–35 °C to dissolve. Filter the solution and store it in a glass bottle wrapped with aluminum foil at room temperature (*see Notes 3 and 4*).
2. Zero percent denature PAGE gel mix: Weight 500 g urea and mix with 100 mL 10× TBE buffer. Dissolve and add diH₂O to 1000 mL. Filter the solution and store it in a plastic Corning bottle at room temperature.

2.3 Other Gel Components and Buffers

1. 10 % ammonium persulfate (APS, FW 228.20): Dissolve 10 g APS in 100 mL diH₂O. Store as 300 µL per aliquot at –20 °C.
2. N, N, N, N'-tetramethyl-ethylenediamine (TEMED, FW 116.20).
3. 2× denaturing gel tracking dye: mix the following components in a 100 mL bottle: 90 mL formamide (FW 45.04, final concentration 90 %), 40 mg NaOH (final concentration 10 mM), 37 mg EDTA·Na₂ (final concentration 1 mM), and 100 mg bromophenol blue (FW 669.96, final concentration 0.1 %).
4. 10× Native tracking dye: 200 mg bromophenol blue (final concentration 0.2 %), 50 mL glycerol (final concentration 50 %), 10 mL annealing buffer, and add 40 mL diH₂O.
5. DNA elution buffer: 19.27 g ammonium acetate (FM 77.08, final concentration 500 mM), 1.07 g magnesium acetate (FW 214.46, final concentration 10 mM), 2 mL of 0.5 M EDTA (pH 8.0, final concentration 2 mM), add diH₂O to 500 mL.

2.4 Cell Medium and Buffers

1. Complete RAW cell culture medium: Dulbecco's modified Eagle's medium (DMEM) supplemented with 10 % fetal bovine serum (FBS), penicillin (100 U mL⁻¹), and streptomycin (0.1 mg mL⁻¹).
2. Staining buffer: mix 2 g BSA and 0.2 g NaN₃ with 100 mL 1× PBS buffer, filter through 0.22 μm syringe filter, and store at 4 °C.
3. Polymyxin B (PMB) sulfate stock: dissolve 1 g PMB in 10 mL endotoxin-free ultrapure water. Store the 100 mg/mL stock solutions in DNase, RNase, pyrogen free 1.5 mL tubes as aliquots at -20 °C. Dilute with endotoxin-free ultrapure water to 10 mg/mL and store in DNase, RNase, pyrogen free 1.5 mL tubes as aliquots at -20 °C.
4. RPMI/Mg²⁺: dissolve 19.8 g magnesium chloride tetra hydrate (MgCl₂·4H₂O) in 100 mL diH₂O to make the 1 M Mg²⁺ stock buffer and autoclave. Store it at room temperature. Mix 100 μL 1 M Mg²⁺ stock buffer with 8 mL RPMI-1640 medium to get 12.5 mM RPMI/Mg²⁺ buffer; mix 100 μL 1 M Mg²⁺ stock buffer with 12.5 mL RPMI-1640 medium to get 8 mM RPMI/Mg²⁺ buffer; mix 50 μL 1 M Mg²⁺ stock buffer with 12.5 mL RPMI-1640 medium to get 4 mM RPMI/Mg²⁺ buffer; for the in vitro stability test.

2.5 Other Reagents

1. Streptavidin, Alexa Fluor 546[®] conjugates (SA-Alexa Fluor 546): Life Technologies (S-11225), excitation maximum at 556 nm and emission maximum at 573 nm.
2. YOYO-[®]1 Iodide: Life Technologies (Y3601), 1 mM solution in DMSO, excitation maximum at 491 nm and emission maximum at 509 nm.
3. Streptavidin Dylight 488: Vector Laboratories (SA-5488-1), excitation maximum at 493 nm and emission maximum at 518 nm.
4. Phycoerythrin (PE) anti-mouse CD40 antibody: BioLegend, clone 3/23.
5. Mouse FcR block: LEAF[™] purified anti-mouse CD16/32 antibody from BioLegend, clone 93.
6. ELISA substrate: 4-nitrophenyl phosphate disodium salt hexahydrate from Sigma-Aldrich.

3 Methods

3.1 Purification of DNA Oligos

1. Cast the denaturing gel: Mix the 20 % denaturing PAGE gel mix and 0 % denaturing PAGE gel mix following the recipe in Table 1 in a 50 mL conical tube. Add 300 μL 10 % APS and 20 μL TEMED, gently swirl, and immediately cast gel in 18 cm × 16 cm × 1.5 mm glass gel cassette. Insert a one-well gel comb immediately without introducing air bubbles.
2. Leave the gel casting assembly on the bench at room temperature undisturbed for around 30 min for the gel to polymerize.

Table 1
Denaturing PAGE gel recipe

Gel percentage	5 %	6 %	8 %	10 %	12 %	14 %	20 %
20 % Denature PAGE mix (mL)	8.75	10.5	14	17.5	21	24.5	35
0 % Denature PAGE mix (mL)	26.25	24.5	21	17.5	14	10.5	0
Separates bp	70–300	45–70	35–45	25–35			8–25
Bromophenol blue runs around bp	35	26	19	12	8		

3. While waiting for the gel to polymerize, prepare the DNA samples:
 - (a) Turn on the heat block to a final temperature of 90 ° C.
 - (b) Add diH₂O to each dry sample to make 0.5 OD/μL. Vortex each sample tube for 20 s and spin at 300×g for 30 s.
 - (c) Take 40 OD of each sample (80 μL) in newly labeled 1.5 mL tubes for each gel (the rest of the samples should go back to freezer at –20 ° C). Add equal volume of 2× denaturing dye to each sample, vortex for 10 s to mix, spin for 30 s.
 - (d) Heat the sample at 90 ° C in heat block for 5 min (*see Note 5*).
 - (e) Immediately load the heated DNA samples to the single well of the denaturing gel, and run gel in 1× TBE buffer with constant current at 50 mA for 50–90 min or till the tracking dye reach to the bottom of gels. A circulating water bath set at 45 ° C may be used.
4. Stop and take the gel out. Transfer it to a white, silica-coated plate that is wrapped with plastic foil. Visualize the DNA band under a short wavelength UV light (254 nm). Cut the most intense band and chop gel into small pieces. Soak the gel pieces into 1.5–2 mL elution buffer and elute at room temperature overnight.
5. Transfer the supernatant into new 1.5 mL tubes at 500 μL per tube and discard the gel pieces. Add 1 mL 100 % ethanol into each tube and vortex before incubating at –20 ° C for 30 min.
6. Spin the mixture of eluted DNA and ethanol in the microcentrifuge at 4 ° C with a speed of 15,000×g for 30 min. Discard the supernatant and keep the bottom white pellet. Wash pellet with ice-cold 70 % ethanol and spin again at 15,000×g for 30 min. Discard the supernatant as much as possible and dry the DNA pellet in the air overnight or in the vacufuge for 1 h.
7. Dissolve the DNA pellet in ultrapure water and read the absorbance at 260 nm on a NanoDrop or UV photometer. Calculate the molar concentration of DNA by dividing the OD₂₆₀ with the molar extinction coefficient provided by the company. Convert the DNA concentration into μM for following calculations. Store purified DNA oligos at –20 ° C (*see Note 6*).

3.2 Assembly of DNA Tetrahedron Nanostructures (TH-CpG)

1. After measuring the DNA molar concentration, mix oligos by a molar ratio of strand L: M: CpG: S=1: 3: 3: 3, with the final concentration of strand L at 1 μM . Dilute the oligo mixture with annealing buffer ($10\times\text{TAE}/\text{Mg}^{2+}$) and ultrapure water to a final concentration of $1\times\text{TAE}/\text{Mg}^{2+}$. The final molar concentration of annealed TH-CpG is 250 nM.
2. Aliquot the diluted DNA mixture into 100 μL per PCR tube and anneal in the thermal cycler following the annealing program below:
90 $^{\circ}\text{C}$ for 5 min, decrease from 89 $^{\circ}\text{C}$ to 71 $^{\circ}\text{C}$ at 5 min per degree; 70 $^{\circ}\text{C}$ to 40 $^{\circ}\text{C}$ at 15 min per degree; 39 $^{\circ}\text{C}$ to 25 $^{\circ}\text{C}$ at 10 min per degree; then keep at 4 $^{\circ}\text{C}$. The total annealing program takes around 12 h (*see* **Notes 7 and 8**).

3.3 Characterization of Assembled DNA Nanostructures by Non-denaturing PAGE Gel

1. Cast 4 % non-denaturing PAGE gel: mix 4 mL annealing buffer and 4 mL 40 % acrylamide stock solution (19:1 Ac-Bis) with 32 mL diH_2O in a 50 mL conical tube. Add 300 μL 10 % APS and 20 μL TEMED into the mixture, gently swirl and quickly pour into an 18 cm \times 16 cm \times 1.5 cm glass cassette. Insert a 15-well gel comb immediately without introducing air bubble. Allow gel to stand at room temperature for 1 h to solidify.
2. Mix 9 μL annealed DNA nanostructure with 1 μL of $10\times$ native tracking dye and directly load to the gel without heating. Set the water bath at 37 $^{\circ}\text{C}$ and run the gel in $1\times\text{TAE}/\text{Mg}^{2+}$ buffer with constant voltage at 200 V for 90 min (*see* **Note 9**).
3. Stop and take the gel out by gently wrapping the gel. Soak the gel in ethidium bromide staining tank and unwrap it. Stain the gel for 5–10 min and destain it in water for 2 min. Image the gel on a UV gel scanner (Fig. 1, *see* **Note 10**).

3.4 In Vitro Stability Analysis of Streptavidin (SA)-TH-CpH Vaccine Complex

1. Mix 100 μL 250 nM TH-CpG with 4 μL of 1 mg/mL SA-Alexa Fluor 546 at room temperature for 10 min, and then add 4 μM YOYO-1 DNA intercalator dye. Incubate at room temperature for 45 min to allow dual-labeling of SA-TH-CpG.
2. Add different concentrations of MgCl_2 to RPMI medium. The final concentration of Mg^{2+} is 12.5 mM, 8 mM, and 4 mM, respectively.
3. For in vitro stability analysis, mix 3 μL of dually labeled SA-TH-CpG with 87 μL RPMI medium/ Mg^{2+} and incubate at 37 $^{\circ}\text{C}$. Measure sample emission spectrum between 490 nm and 650 nm on fluorescence spectrophotometer at various time points, with the excitation wavelength set at 470 nm.
4. Quantify the ratio of acceptor's fluorescent intensity (570 nm) to donor's fluorescent intensity (510 nm). Define this Acceptor to Donor (A/D) ratio as the stability of DNA nanostructures.

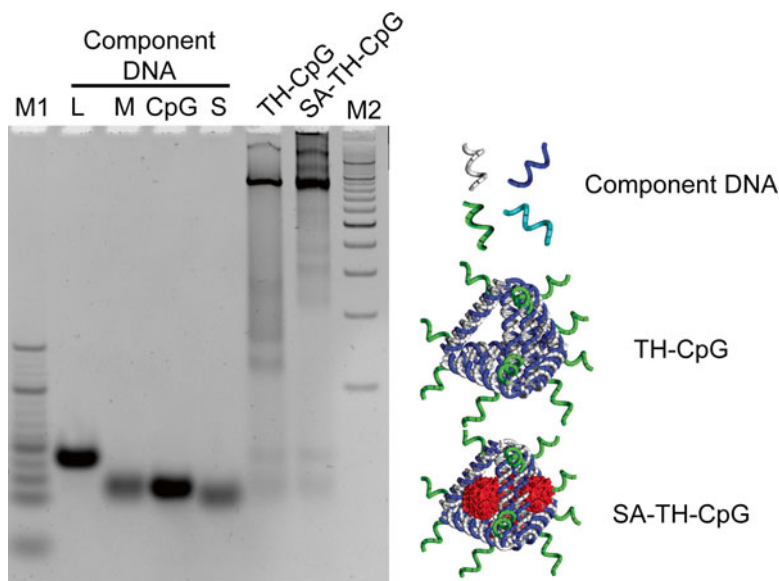

Fig. 1 Characterization of DNA nanostructure assembly by 4 % non-denaturing PAGE gel. Lanes from *left to right* are: 10 bp DNA ladder (M1); component DNA strands (strand L, M, CpG, and S), where band intensities are influenced by both oligo length and secondary structures; Tetrahedron-CpG (TH-CpG) nanostructures with and without streptavidin (SA); 100 bp DNA ladder (M2)

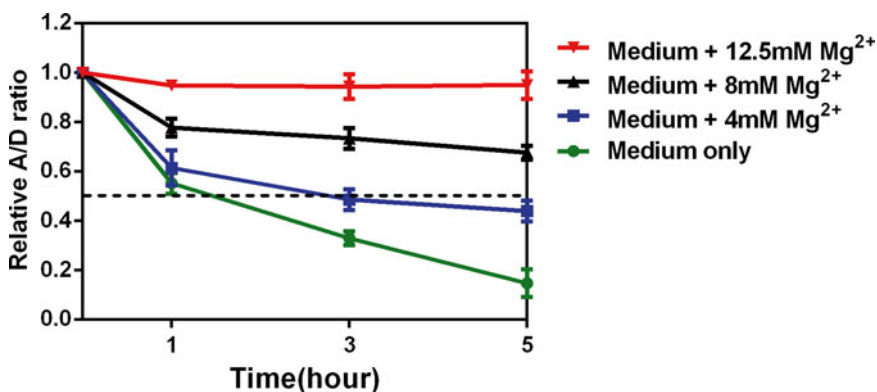

Fig. 2 Effect of Mg²⁺ concentrations on the stability of DNA nanostructures. The ratio of fluorescence intensity of Acceptor to Donor, i.e., A/D ratio, was used to assess structural stability of DNA nanostructure under different concentrations of Mg²⁺. The A/D ratio post incubation was normalized by the A/D ratio at time 0, presenting as relative A/D ratio (*y*-axis). Each data point is the average of 3 independent experiments along with standard error. The *red, black, blue, and green lines* represent the change of relative A/D ratios over time in buffer containing Mg²⁺ at the final concentration of 12.5 mM, 8 mM, 4 mM, and 0, respectively

3.5 Cellular Internalization of DNA Nanostructures by Flow Cytometry

1. Maintain RAW264.7 cell line in complete culture medium at 37 °C with 5 % carbon dioxide (CO₂), and seed the RAW264.7 cells into 12-well plate at the density of 5 × 10⁵ cells per well in 1 mL complete culture medium.
2. Mix 5.5 μL of 1 mg/mL SA-DyLight488 with 100 μL 1× TAE/Mg²⁺ buffer, or 100 μL 250 nM TH-CpG nanostructure

or 100 μL 3 μM 5' biotin-CpG in 1 \times TAE/ Mg^{2+} buffer and incubate at room temperature for 30 min to form SA488 alone, SA488-TH-CpG, or SA488-CpG respectively.

3. Add 20 μL of each diluent above into separate wells of cells and incubate at 37 $^{\circ}\text{C}$ for 5 min or 1 h.
4. Collect cells by pipetting with 1 mL pipettor and transfer to flexible U-bottom 96-well plate.
5. Spin at 380 $\times g$ for 5 min at 4 $^{\circ}\text{C}$ and aspirate supernatant.
6. Add 30 μL DNase-1 (10 U/mL) and trypsin to the cell pellet and incubate at 37 $^{\circ}\text{C}$ for 5 min. Wash twice with staining buffer.
7. Resuspend cells in 200 μL staining buffer each and analyze the mean fluorescence intensity (MFI) of Dylight 488 on BD FACSCalibur.

3.6 In Vitro Stimulation Assay of Adjuvant

1. Maintain RAW264.7 cell line in complete culture medium at 37 $^{\circ}\text{C}$ with 5 % carbon dioxide (CO_2).
2. Harvest RAW264.7 cells at 60–70 % confluency using a cell scraper. After cell numeration with a hemocytometer, seed the cells into a 48-well plate at the density of 1×10^5 cells in 250 μL medium per well. Culture cells in a 37 $^{\circ}\text{C}$ incubator with 5 % CO_2 overnight.
3. After overnight culture, aspirate the old medium from each well, and add fresh complete culture medium that is mixed with polymyxin B sulfate (50 $\mu\text{g}/\text{mL}$) to exclude the stimulatory effect resulting from endotoxin contamination possibly present in the testing samples (*see Note 11*).
4. Dilute free streptavidin (SA), free CpG ODN, or SA-TH-CpG in 1 \times TAE/ Mg^{2+} buffer to the concentration of 1 μM SA and 3 μM CpG or equivalent, respectively, in a volume of 15 μL . Then add 12.5 μL of such diluents (i.e., either CpG ODN or SA-TH-CpG) to individual wells.
5. Incubate for 20–24 h, detach and harvest cells by repetitive pipetting with 1 mL pipette. Collect the cells onto a U-bottom flexible 96-well plate.
6. Pellet cells by spinning at 380 $\times g$ for 5 min at 4 $^{\circ}\text{C}$ and wash cells by staining buffer
7. Stain cells with PE anti-mouse CD40 (1 $\mu\text{g}/\text{mL}$) and mouse FcR block (1 $\mu\text{g}/\text{mL}$) at 4 $^{\circ}\text{C}$ for 30 min and wash twice with staining buffer
8. Analyze the surface CD40 expression of stimulated cells on BD FACSCalibur.
9. The adjuvant activity is characterized by analyzing the MFI of PE to compare the level of CD40 expression after stimulation.

3.7 Mouse Immunization

1. Assemble vaccine complexes by mixing 100 μL of annealed DNA TH-CpG (equivalent to 2 μg CpG) with 5.5 μg SA at room temperature for 30 min, which is the amount of antigens utilized for immunization of each mouse. Adjust the amount of assembly according to the number of immunizing animals (*see Note 12*).
2. Randomly assign 6-week-old female mice at five per cage and acclimate them for at least 1 week prior to vaccination. Immunize the mice subcutaneously (either in the back or at the tail base) with the fully assembled SA-TH-CpG vaccine. Give additional boosting immunizations to enhance the immunogenicity of the vaccines (*see Note 13*).
3. Collect the blood from the facial veins at various times post the primary, secondary or tertiary immunization. Spin at $2000\times g$ at 4 $^{\circ}\text{C}$ for 10 min and save the supernatant serum. Store mouse serum as aliquots at -80°C freezer. Analyze samples by direct ELISA for quantitative measurements of anti-SA antibodies.

3.8 Quantification of Antibody Responses by ELISA

1. Coat MaxiSorp 96-well ELISA plates with 1 $\mu\text{g}/\text{mL}$ SA in coating buffer at 50–100 μL per well. Cover the plates with sticky plate sealer and keep them overnight at room temperature.
2. Aspirate the ELISA plates and wash once with washing buffer. Block the plates with 100 μL ELISA blocking buffer per well at 37 $^{\circ}\text{C}$ for 1 h (*see Note 14*).
3. Wash the plates three times with washing buffer. Prepare mouse serum samples in ELISA blocking buffer with a serial dilution in a U-bottom flexible 96-well plate. Similarly, dilute the commercial anti-SA antibody with known concentration in ELISA blocking buffer via a serial dilution to use it as a standard for estimating the level of anti-SA antibodies made in the serum.
4. Add the diluted serum samples and anti-SA antibody standard to the ELISA plates and incubate them at 37 $^{\circ}\text{C}$ for 2 h.
5. Wash the plates three times with washing buffer and add alkaline phosphatase conjugated anti-mouse IgG+IgM that is diluted in ELISA blocking buffer following the dilution factors recommended by the manufacturer. Incubate the plates at 37 $^{\circ}\text{C}$ for 1 h.
6. Wash the plates three times with ELISA washing buffer and add the plates with the substrate solution, 4-nitrophenyl phosphate disodium salt hexahydrate. Incubate the plate at room temperature until the top row of standard antibody reaches to OD₄₀₅ of 0.6–1.0, while maintaining the color gradient.
7. Stop the reaction by adding 25 μL 0.3 M NaOH to each well. Read the plate on a standard 96-well plate reader at 405 nm. Calculate the concentrations of anti-SA antibodies in the serum samples by fitting the OD₄₀₅ to the standard curve that is generated from the standard antibody.

4 Notes

1. The annealing buffer should be prepared and stored as sterile to avoid any pathogen contamination in the final vaccine sample.
2. 10× TBE buffer tends to form precipitates after long term storage, and therefore dilution as 1× TBE buffer (also the running buffer for denature gels) is recommended, except for making the 20 % and 0 % denaturing PAGE gel mix.
3. When making 20 % denaturing PAGE gel mix, slight heating at 30–35 °C is recommended to help the dissolve of urea. But overheat or long time heating is not recommended as they may cause decomposition.
4. 20 % denaturing PAGE gel mix should be stored in dark or wrapped with aluminum foil to prevent decomposition by light.
5. Do not overheat the sample.
6. Concentrations of DNA oligos should be measured and calculated in a precise manner, and the strand stoichiometry should be strictly followed, as the DNA strand stoichiometry greatly influences the assembly yield of DNA tetrahedron nanostructure.
7. After the annealing of DNA nanostructures, they can be stored at 4 °C for weeks. However, it is recommended to be used within 2 weeks.
8. Purified DNA strands should be stored at –20 °C for long term storage. However, annealed DNA nanostructures cannot be stored at –20 °C as freezing may destroy the assembled nanostructure. If put to –20 °C by accident, the annealed samples may be re-annealed with the same PCR program after thawing to room temperature.
9. When running the 4 % native gel, it is important to ensure the running buffer in lower tank covers up to the bottom of wells. This helps control the gel temperature during running and prevent DNA tetrahedron disassembly caused by gel overheating.
10. Be extra gentle when handling 4 % native gels. Wrap the gel before lift it to prevent breaking gel into pieces.
11. Handle PMB solution with caution to prevent endotoxin contamination.
12. When assembling the DNA nanostructures and mixing with SA to construct the final vaccine complexes, it is important to use sterile tubes and sterile pipette tips and to operate in a tissue culture hood.
13. For immunization at the mouse tail base, use a tail access rodent restrainer for better control of mice. After tail base injection, it is normal to see a small bulge at the injection site.
14. For ELISA, automated plate washer may provide better washing efficiency and help reduce the background.

Acknowledgement

We thank Jacquelyn Kilbourne for her help in animal work. We also thank Tong Fu for her assistance in flow cytometry. This work was supported by grants from the National Institute of Health (CA141021, DA030045, and DA03555 to Y.C.).

References

1. Anderson RP, Jabri B (2013) Vaccine against autoimmune disease: antigen-specific immunotherapy. *Curr Opin Immunol* 25:410–417
2. Melero I, Gaudernack G, Gerritsen W, Huber C et al (2014) Therapeutic vaccines for cancer: an overview of clinical trials. *Nat Rev Clin Oncol* 11:509–524
3. Shen XY, Orson FM, Kosten TR (2012) Vaccines against drug abuse. *Clin Pharmacol Ther* 91:60–70
4. Peek LJ, Middaugh CR, Berkland C (2008) Nanotechnology in vaccine delivery. *Adv Drug Deliv Rev* 60:915–928
5. Sharma R, Agrawal U, Mody N, Vyas SP (2015) Polymer nanotechnology based approaches in mucosal vaccine delivery: Challenges and opportunities. *Biotechnol Adv* 33:64–79
6. Liu Y, Lin C, Li H, Yan H (2005) Aptamer-Directed Self-Assembly of Protein Arrays on a DNA Nanostructure. *Angew Chem Int Ed* 44:4333–4338
7. Zhang C, Su M, He Y, Leng Y et al (2010) Exterior modification of a DNA tetrahedron. *Chem Commun* 46:6792–6794
8. Li J, Pei H, Zhu B, Liang L et al (2011) Self-assembled multivalent DNA nanostructures for noninvasive intracellular delivery of immunostimulatory CpG oligonucleotides. *ACS Nano* 5:8783–8789
9. Schuller VJ, Heidegger S, Sandholzer N, Nickels PC et al (2011) Cellular immunostimulation by CpG-sequence-coated DNA origami structures. *ACS Nano* 5:9696–9702
10. Douglas SM, Bachelet I, Church GM (2012) A logic-gated nanorobot for targeted transport of molecular payloads. *Science* 335:831–834
11. Lee H, Lytton-Jean AK, Chen Y, Love KT et al (2012) Molecularly self-assembled nucleic acid nanoparticles for targeted in vivo siRNA delivery. *Nat Nanotechnol* 7:389–393
12. Sharma J, Chhabra R, Cheng A, Brownell J et al (2009) Control of Self-Assembly of DNA Tubules Through Integration of Gold Nanoparticles. *Science* 323:112–116
13. Liu X, Xu Y, Yu T et al (2012) A DNA nanostructure platform for directed assembly of synthetic vaccines. *Nano Lett* 12:4254–4259
14. Seeman NC, Kallenbach NR (1983) Design of immobile nucleic acid junctions. *Biophys J* 44:201–209
15. Yan H, Park SH, Finkelstein G, Reif JH, LaBean TH (2003) DNA-templated self-assembly of protein arrays and highly conductive nanowires. *Science* 301:1882–1884
16. Rothemund PW (2006) Folding DNA to create nanoscale shapes and patterns. *Nature* 440:297–302
17. Douglas SM, Dietz H, Liedl T, Högberg B et al (2009) Self-assembly of DNA into nanoscale three-dimensional shapes. *Nature* 459:414–418
18. Han D, Pal S, Nangreave J, Deng Z et al (2011) DNA origami with complex curvatures in three-dimensional space. *Science* 332:342–346

Alphavirus-Based Vaccines

Kenneth Lundstrom

1 Introduction

Vaccine development has been characterized by defining targets, which generate strong immune responses after vaccination and provide protection against challenges with lethal doses of disease agents. In this context, obvious targets have included infectious diseases and various types of cancers. The classic approach has been to apply attenuated or inactivated viral strains for immunization experiments [1]. More recently, viral surface and core proteins providing antigens for immunization have been identified for vaccine development [2]. This approach has mainly relied on generating high level expression of viral proteins using recombinant technologies. For this purpose, efficient expression vectors have been engineered for alphaviruses based on Semliki Forest virus (SFV) [3], Sindbis virus (SIN) [4], and Venezuelan equine encephalitis virus (VEE) [5]. Moreover, alphavirus vectors have also been applied for vaccine development against cancer [6].

Alphavirus vectors have been used for vaccine development as naked RNA, recombinant viral particles, and layered DNA plasmids [7]. A large number of viral structural proteins such as influenza virus HA (hemagglutinin) [8] and NA (neuraminidase) [9], HIV envelope (Env) [10] and glycoprotein 41 (gp41) [11], and Ebola virus nucleoprotein (NP) [12] and glycoprotein (GP) [13] have been expressed from alphavirus vectors and subjected to immunization studies in a variety of animal models. In this context, vaccination of chicken with recombinant VEE particles provided protection after challenges with lethal doses of influenza virus [8]. Likewise, immunization of primates with VEE particles protected from intramuscular and aerosol challenges with Ebola virus [14]. A number of studies have targeted overexpression of cancer-related genes for obtaining therapeutic efficacy and even protection against

disease development [7]. For instance, immunization with VEE particles expressing the neu gene demonstrated tumor regression in mice [15]. Furthermore, vaccination with SIN-HER2/neu DNA plasmids provided protection of mice challenged with neu overexpressing cancer cells [16]. Interestingly, a single injection with SFV-LacZ RNA presented complete tumor protection, and even immunization 2 days after tumor cell administration extended animal survival for 10–20 days [17]. Due to the association of alphaviruses to epidemics in different parts of the world they serve as attractive targets for vaccine development. For instance, a live attenuated V3526 VEE vaccine showed protection against VEE challenges [18]. Additionally, a new Chikungunya (CHIK) virus was isolated from an acutely infected human patient and subjected to the design of a synthetic DNA vaccine [19].

The success achieved in preclinical animal models has encouraged to subject vaccine programs to clinical trials. In a human phase II, randomized, double-blind, placebo-controlled, safety and immunogenicity study volunteers were subjected to subcutaneous injection of a serially passaged, plaque-purified live CHIK vaccine [20]. Neutralizing antibodies were detected in 98 % of vaccinated individuals and 85 % still remained seropositive a year later. Moreover, a two-component alphavirus replicon vaccine expressing cytomegalovirus (CMV) gB or pp65/1E1 fusion protein was subjected to a phase I randomized, double-blind clinical trial [21]. Intramuscular or subcutaneous administration induced neutralizing antibodies and multifunctional T-cell responses in CMV seronegative adult volunteers. Expression of carcinoembryonic antigen (CEA) from alphavirus particles was subjected to repeated administration in patients with metastatic cancer in another clinical trial [22]. The elicited CEA-specific antibodies demonstrated cellular toxicity against colorectal cancer metastases and showed extended overall survival in patients with CEA-specific antibodies. In another human clinical trial, patients with metastatic cancers were immunized with VEE replicons expressing the prostate-specific membrane antigen (PSMA) [23]. A weak PSMA-specific signal was observed, but disappointingly no clinical benefit was achieved.

2 Materials

One key component in applying alphavirus vectors for vaccine development is the preparation of delivery vehicles for immunization experiments. The approaches are obviously different depending on whether naked RNA, recombinant viral particles or layered DNA vectors are used. Similarly, the immunization procedures depend on the type of vector applied.

1. Cell cultures

Recombinant alphavirus particles are propagated in BHK-21 (baby hamster kidney) cells cultured in a 1:1 mixture of Dulbecco's modified F-12 medium (Gibco BRL) and Iscove's modified Dulbecco's medium (Gibco BRL) supplemented with 4 mM glutamine and 10 % fetal calf serum (FCS).

2. Alphavirus plasmid vectors

SFV-, SIN-, and VEE-based expression vectors share common features and for simplicity the focus below will be on SFV only. Replication-deficient recombinant particles are generated from expression vectors pSFV1 and pSFV2gen (also called pSFV4.2) together with the pSFV-Helper2 vector (Fig. 1). The vectors pSFV1 and pSFV-Helper2 are linearized by *Spe*I and pSFV-2gen by *Nru*I. Moreover, modified vectors providing enhanced expression [24] and reduced cytotoxicity [24, 25] have been engineered.

3. Reagents and Equipment

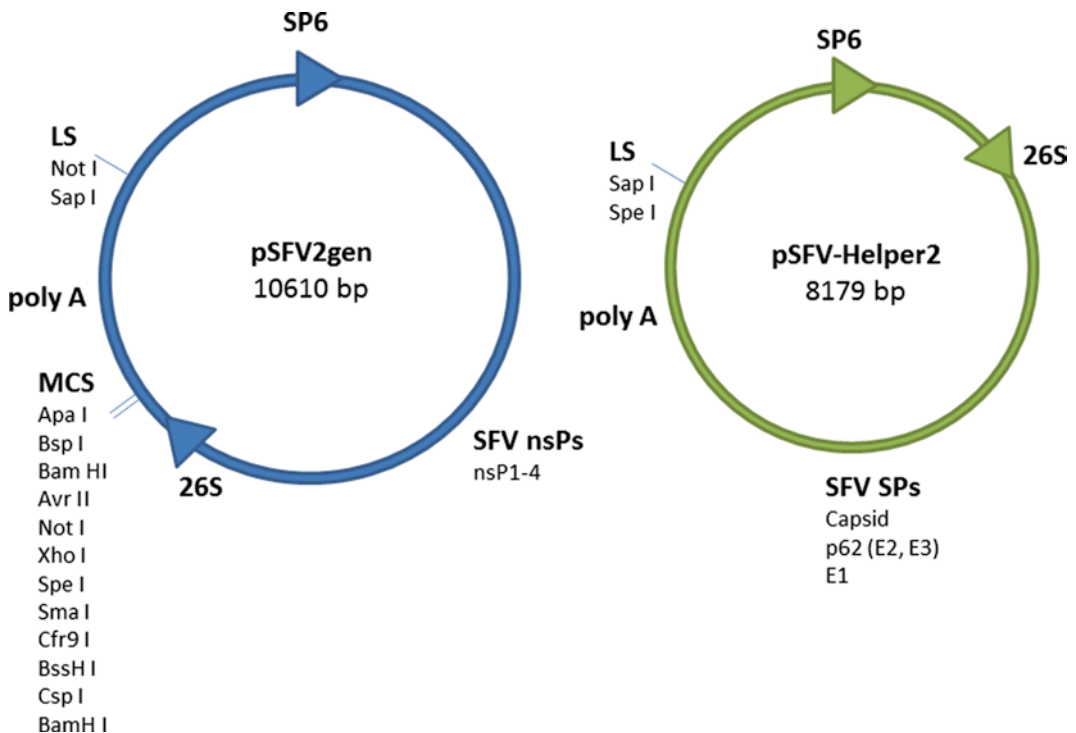

Fig. 1 SFV expression and helper vectors. Expression vector pSFV2gen and its derivative used for insertion of foreign genes of interest in the multi-cloning site (MCS). Both expression and helper vectors contain SP6 RNA polymerase promoter (SP6), SFV 26S promoter for expression of genes of interest and structural proteins (SPs), respectively. The genes coding for the nonstructural proteins (nsPs) and the polyadenylation signal (poly A) are indicated. Alternative linearization sites (LS) can be used

- Restriction endonucleases *SpeI*, *NruI* (Roche Molecular Biochemicals)
- 0.8 % agarose gel (Q-Biogene)
- Gel electrophoresis apparatus (Bio-Rad)
- Phenol–chloroform–isoamyl alcohol 25: 24:1 (v/v/v) (Gibco BRL)
- 3 M Sodium acetate, pH 4.8 (Fluka)
- 95 % and 70 % (v/v) ethanol (Merck)
- 10× SP6 Buffer: 400 mM HEPES, pH 7.4, 60 mM magnesium acetate, 20 mM spermidine
- 10 mM m⁷G(5′)ppp(5′)G sodium salt (Roche Molecular Biochemicals)
- 50 mM dithiothreitol (DTT) (Fluka)
- rNTP Mix: 10 mM rATP, 10 mM rCTP, 10 mM rUTP, 5 mM rGTP (Roche Molecular Biochemicals)
- 10–50 U/μL RNase inhibitor (Roche Molecular Biochemicals)
- 10–20 U/μL SP6 RNA polymerase (Amersham Pharmacia Biotech)
- Phosphate buffered saline (PBS) (Gibco BRL)
- Trypsin–ethylenediamine tetra-acetic acid (EDTA): 0.25 % trypsin, 1 mM EDTA × 4 Na) (Gibco BRL)
- Microcentrifuge, 1.5 mL microcentrifuge tubes (Eppendorf)
- Heating blocks and water baths (Eppendorf/Julabo)
- Sterile electroporation cuvettes, 0.2 and 0.4 cm (Bio-Rad or BTX)
- Electroporator (Bio-Rad Gene Pulser)
- Tissue culture flasks (T25, T75, and T175) (Nunc Brand Products)
- Microwell plates (6-, 12-, and 24-well plates) (Costar)
- Falcon tubes (15 and 50 mL) (Becton Dickinson)
- Plastic syringes (1, 10, and 50 mL) (Becton Dickinson)
- Sterile 0.22 μm filters (Millipore)
- MicroSpin™ S-200 HR Columns (Amersham)
- Dulbecco's modified F-12 medium (Gibco BRL)
- Iscove's modified Dulbecco's medium (Gibco BRL)
- Opti-MEM I reduced-serum medium (Gibco BRL)
- X-gal stock solutions: 50 mM K ferricyanide, 50 mM K ferrocyanide, 1 M MgCl, 2 % X-gal in DMF or DMSO

- X-gal staining solution: 1× PBS, 5 mM K ferricyanide, 5 mM K ferrocyanide, 2 mM MgCl, 1 mg/ml X-gal
- Mowiol 4-88 containing 2.5 % DABCO (1,4-diazobicyclo-[2.2.2]-octane)
- Lysis buffer: 50 mM Tris–HCl pH 7.6, 150 mM NaCl, 2 mM EDTA, 1 % (v/v) Nonidet P-40 (NP40) (Sigma)
- Hybond ECL nitrocellulose filter (Amersham)
- TBST (TBS with 0.1 % Tween 20)
- ECL Chemiluminescence kit (Amersham)
- Starvation medium: methionine-free MEM, 2 mM glutamine, 20 mM HEPES
- Chase medium: E-MEM, 2 mM glutamine, 20 mM HEPES, 150 µg/mL unlabeled methionine
- BHK-21 cells (ATCC CCL-10)
- CHO-K1 cells (ATCC CCL-61)
- COS7 cells (ATCC CRL-1651)
- HEK293 cells (ATCC CRL-1573)

3 Methods

3.1 Subcloning into SFV Vectors

General subcloning procedures are followed for introduction of genes of interest into the multiple cloning sites (MCS) of the SFV expression vectors. Because the region between the MCS and the linearization sites contains the RNA replication and polyA⁺ signals the linearization sites (*SpeI*, *SapI*, and *NruI*) in SFV cannot be used as cloning sites. Restriction endonuclease digestions and nucleotide sequencing are applied for insert verifications. The preparation of high purity DNA (Midiprep or Maxiprep DNA) is recommended for in vitro transcription reactions (*see Note 1*).

3.2 DNA Linearization

1. Recombinant SFV plasmids are linearized by *SpeI*, *SapI*, or *NruI* under standard restriction digestion conditions.
2. After confirmation of complete digestions by agarose gel electrophoresis the linearized DNA is purified by phenol–chloroform extraction followed by ethanol precipitation (overnight at –20 °C or 15 min at –80 °C).
3. Ethanol precipitates are centrifuged for 15 min at 18,000 × *g* at +4 °C and washed with 70 % ethanol. After repeated centrifugation for 5 min, the DNA pellet is air-dried or lyophilized and resuspended in RNase-free H₂O at a final concentration of 0.5 µg/µL. MicroSpin™ S-200 HR Column purification can be alternatively used for DNA purification.

3.3 *In Vitro* Transcription

It is recommended that in vitro transcribed RNA is prepared fresh for immunizations or electroporation although RNA transcripts can be stored for shorter periods (weeks) at -80°C . Most importantly, the in vitro transcription reactions should be set up at room temperature as the SP6 buffer contains spermidine, which might lead to precipitation at lower temperatures. Enzyme components should be added last. Despite the availability of commercial in vitro transcription buffers, it is recommended that the optimized SP6 RNA polymerase buffer below is used (*see Note 2*).

In Vitro Transcription Reaction

5 μL (2.5 μg) linearized plasmid DNA

5 μL 10 \times SP6 buffer

5 μL 10 mM $m^7\text{G}(5')\text{ppp}(5')\text{G}$

5 μL 50 mM DTT

5 μL rNTP mix

x μL RNase-free H_2O to reach a final volume of 50 μL

1.5 μL (50 U/ μL) RNase Inhibitor

3.5 μL (20 U/ μL) SP6 RNA polymerase

1. All reaction components are mixed and incubated for 1 h at 37°C (*see Note 3*).
2. The quality of in vitro transcribed RNA is assessed by agarose gel electrophoresis of 1–4 μL aliquots. An indication of high quality RNA is thick bands without smearing with an approximate mobility of 8 kb (compared to DNA markers) from the expression vector and a slightly faster mobility of helper RNA (Fig. 2).

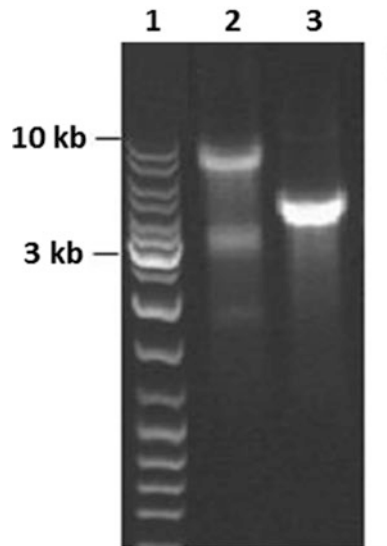

Fig. 2 Analysis (quality control) of in vitro transcribed RNA. Samples from in vitro transcription reactions are loaded on 0.8 % agarose gel. *Lane 1*: DNA ladder; *lane 2*: pSFV-GFP RNA; *lane 3*: pSFV-Helper2 RNA

3. In vitro transcribed RNA can be directly subjected to electroporation or lipid-mediated transfection or stored for weeks at -80°C . In case of using frozen samples, the quality of RNA should be reevaluated by agarose gel electrophoresis. Each in vitro transcription reaction is anticipated to generate 20–50 μg of RNA.

3.4 Electroporation of RNA

Although BHK-21 cells are known to produce high-titer SFV stocks alternative host cells can be considered.

1. Cells with a low passage number are cultured in T175 flasks to no more than 80 % confluency, washed once with PBS and trypsinized with 6 mL trypsin–EDTA per T175 flask for 5 min at 37°C .
2. After resuspension in 25 mL cell culture medium, the cells are centrifuged for 5 min at $800\times g$ and the cell pellet resuspended in a small volume (<5 mL) of PBS.
3. The volume is increased to 25 mL with PBS and cells are recentrifuged for 5 min at $800\times g$.
4. Finally, cells are resuspended in approximately 2.5 mL PBS per T175 flask, equivalent to $1\text{--}2\times 10^7$ cells per mL. Cells should be used immediately for electroporation although shorter storage (<1 h) on ice is acceptable.
5. Next 0.4 mL BHK-21 cell suspension is transferred to 0.2 cm cuvettes or 0.8 mL to 0.4 cm cuvettes. In vitro transcribed recombinant RNA (20–45 μL) and helper RNA (20 μL) are added to the cell suspension and two consecutive pulses are applied with the following settings for the Bio-Rad Gene Pulser:

	0.2 cm cuvette	0.4 cm cuvette
Capacitance extender	960 μF	960 μF
Voltage	1500 V	850 V
Capacitor	25 μF	25 μF
Resistance (pulse controller)	$\infty \Omega$	Disconnected
Expected time constant (TC)	0.8 s	0.4 s

The Bio-Rad Gene Pulser II requires the following modifications:

- The pulse controller should be set to “high range” and “ ∞ ”
- The capacitance rotary switch should be set to “high capacitance”

- The following settings should be applied: 360 V and 75 μF
 - The obtained resistance for 0.2 cm cuvettes is 10 Ω and the time constant 0.7–0.8 s
6. Cells are immediately diluted 25-fold in cell culture medium and transferred to T flasks or plates for overnight incubation at 37 °C in an incubator with 5 % CO_2 .

3.5 Lipid-Mediated Transfection of RNA

As an alternative to electroporation DMIRIE-C and other transfection reagents can be applied for BHK-21, COS7 and CHO-K1 cells.

1. BHK-21 cells ($1.5\text{--}3 \times 10^5$) in 35 mm petri dishes or on 6-well plates are cultured to approximately 80 % confluency.
2. After washing cells with Opti-MEM I reduced-serum medium, the following cationic lipid-RNA complexes are prepared: 0, 3, 6, 9, 12, and 15 μL of DMRIE-C to six 1.5 mL microcentrifuge tubes with 1 mL Opti-MEM I reduced-serum medium at room temperature.
3. Next, 10 μL ($\sim 5 \mu\text{g}$) in vitro transcribed recombinant RNA and 5 μL ($\sim 2.5 \mu\text{g}$) helper RNA are mixed, added to each tube and vortexed briefly.
4. The lipid-RNA complexes are added immediately to the washed cells and incubated at 37 °C for 4 h.
5. The transfection medium is replaced with pre-warmed (37 °C) complete BHK medium and the BHK cells incubated at 37 °C overnight in an incubator with 5 % CO_2 .

3.6 Harvest of Recombinant Viral Particles

Recombinant SFV particle production in the range of 10^8 to 10^9 infectious particles per mL occurs within the first 24 h.

1. Virus particles are harvested by carefully removing the medium from the BHK-21 cells.
2. Filter-sterilization through a 0.22 μm filter removes cell debris and possible contaminants.
3. Because repeated cycles of freezing and thawing can reduce the titers significantly it is advisable to aliquot virus stocks before stored at $-20 \text{ }^\circ\text{C}$ (for weeks) and at $-80 \text{ }^\circ\text{C}$ (for years).

3.7 Activation of Recombinant SFV Particles

Utilization of the conventional SFV helper vectors generates fully infectious particles. However, recombination may generate replication-competent particles at a low frequency, which has been eliminated by engineering a second generation pSFV-Helper2 vector for the production of conditionally infectious particles [26].

1. Activation of particles takes place by addition of α -chymotrypsin at a final concentration of 500 $\mu\text{g}/\text{mL}$ for 20 min at room temperature.

2. The reaction is terminated with Aprotinin (trypsin inhibitor) at a final concentration of 250 µg/mL.

3.8 Verification of Virus Titers

The replication-deficient nature of recombinant virus particles generates no plaques, which limits titer determination. Indirect titers can be estimated by determination of the number of infected cells for reporter gene expression.

1. BHK-21 (or other) cells are cultured to a defined concentration on 6- or 12-well plates or on coverslips before infection with serial dilutions (e.g., fivefold dilutions in the range expected to give 20–50 positive cells per microscope field) of virus stocks expressing GFP or β-galactosidase.
2. After incubation at 37 °C titers are estimated no later than 48 h post-infection because especially mutant vectors may provide a suboptimal signal at earlier time points and later on cytopathic effects increase the number of detached cells.

Moreover, immunofluorescence methods can be applied. As alphavirus infection cause cell morphology changes (round up) microscopic examination can also provide an approximate estimation of titers.

3.8.1 GFP Detection

The number of GFP positive cells is counted applying fluorescence microscopy. The approximate titers are determined as infectious particles/mL based on the number of GFP positive cells per well and taken into account the virus dilution.

3.8.2 X-Gal Staining

The number of β-galactosidase positive cells is counted applying light microscopy.

1. Cells are washed with PBS, fixed in cold methanol at –20 °C for 5 min and washed again three times with PBS.
2. Next cells are stained for at least 2 h in X-gal staining solution at 37 °C or room temperature.
3. The number of X-gal (blue) positive cells is counted and the titers estimated as described for GFP detection.

3.8.3 Immuno fluorescence

1. Coverslips with cultured cells are rinsed twice with PBS and fixed for 6 min at –20 °C in methanol.
2. Coverslips are washed three times in PBS and incubated for 30 min at room temperature in PBS containing 0.5 % gelatin and 0.25 % BSA to prevent unspecific binding.
3. The blocking buffer is replaced with a primary antibody in the same buffer for 30 min at room temperature.
4. After washing three times with PBS and incubated with a secondary antibody for 30 min at room temperature, the cover-

slips are washed again three times with PBS and once with H₂O, and air-dried.

5. Finally the coverslips are mounted on glass slides using 10 μL Mowiol 4-88 containing 2.5 % DABCO (1,4-diazobicyclo-[2.2.2]-octane) and the number of positive cells is counted and the titers estimated as described for GFP detection.

3.9 Evaluation of Gene Expression

Before proceeding to any immunization studies, it is advisable to rapidly evaluate the transgene expression from generated virus stocks. Estimation of expression levels and gene product size can be obtained by Western blotting when antibodies are available against the target protein or tag fusions in vector constructs (Fig. 3a). Alternatively, infected cells can be subjected to metabolic labeling with ³⁵S-methionine (Fig. 3b).

3.9.1 Western Blotting

1. Appropriate cells (BHK-21, CHO-K1, HEK293) cultured on 6-, 12-, or 24-well plates are infected with serial dilutions of virus stocks and incubated for 1–2 days at 37 °C.
2. Cells are lysed with 250, 125, and 62.5 μL lysis buffer per 6-, 12-, and 24-well plate, respectively, and incubated for 10 min on ice before samples are loaded on 10–12 % SDS-PAGE.

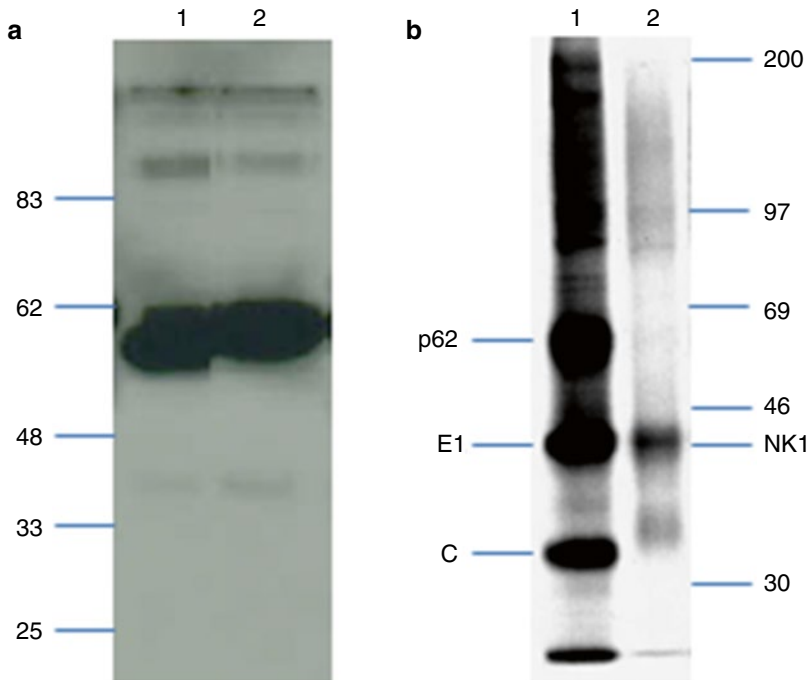

Fig. 3 Expression verification by 10 % SDS-PAGE. **(a)** Western blotting: *Lane 1*: human cannabinoid 2 receptor; *lane 2*: human chemokine receptor 3 detected with anti-His antibody against vector-based His-tag. **(b)** Metabolic labeling: *Lane 1*: BHK-21 cells electroporated with pSFV-NK1 (neurokinin 1 receptor) and pSFV-Helper 2 RNA; *lane 2*: BHK cells infected with recombinant SFV-NK1 virus

3. Electrophoresed protein material is transferred to a Hybond ECL nitrocellulose filters for 30 min.
4. Filters are treated with 5 % milk in TBST at +4 °C for 30 min followed by primary and secondary antibody treatment, each for 30 min at room temperature.
5. Specific bands are visualized with the ECL Chemiluminescence kit.

3.9.2 Metabolic Labeling

1. Host cells (BHK-21, CHO-K1, HEK293) cultured on 6-, 12-, or 24-well plates are infected with serial dilutions of virus stocks and incubated for 1–2 days at 37 °C.
2. The medium is removed, cells washed once with PBS and Starvation medium added.
3. After 30 min at 37 °C the medium is replaced with 50–100 $\mu\text{Ci}/\text{mL}$ of ^{35}S methionine (in Starvation medium) and incubated for 20 min at 37 °C.
4. The medium is removed, cells washed twice with PBS and Chase medium added for appropriate time (15 min to 3 h).
5. After removal of Chase medium, cells are washed once with PBS, 250 μL lysis buffer per 6-well plate added and incubated for 10 min on ice.
6. Samples are loaded on 10–12 % SDS-PAGE under standard conditions, fixed in 10 % acetic acid, 30 % methanol for 30 min at room temperature and replaced with Amplify[®] for 30 min at room temperature.
7. The gel is dried and exposed on Hyperfilm-MP for 2–24 h (depending on signal) at room temperature or at –80 °C applying radioactivity-intensifying screens for visualization.

3.10 Virus Stock Purification

For alphavirus-based preclinical vaccine studies it may be advantageous to prepare further purified virus stocks for immunization studies (*see Note 4*). In case of clinical trial these procedures are mandatory. For this purpose, various methods such as ultracentrifugation and affinity chromatography can be employed.

3.10.1 Ultracentrifugation of Virus Stocks

1. A step gradient is prepared in ultracentrifuge tubes by addition of 1 mL of 50 % sucrose solution (bottom) and 3 mL of 20 % sucrose solution (top).
2. Virus stock solution (9 mL for SW 40 Ti or 8 mL for SW 41 Ti) is added onto the sucrose gradient.
3. Ultracentrifugation is performed at $160,000\times g$ (30,000 rpm in SW 40 Ti or SW41 Ti rotor) for 90 min at +4 °C.
4. The virus will settle near the interface between the 20 % and 50 % sucrose layers and can be collected by discarding the medium fraction and the bottom 0.8 mL consisting of 50 % sucrose.

3.10.2 *Centriprep Concentration*

1. Virus stocks are loaded onto the sample container of the Centriprep concentrator as described by the manufacturer.
2. The assembled concentrator is centrifuged at an appropriate *g*-force (according to the manufacturer's recommendations), until the fluid levels inside and outside the filtrate collector equilibrate.
3. The device is removed, the airtight seal cap snapped off, the filtrate decanted, the cap replaced, and the concentrator centrifuged a second time.
4. The filtrate is decanted, the twist-lock cap is loosed, and the filtrate collector removed.
5. The concentrated virus sample is collected with a 1 mL disposable plastic pipette. If further concentration of virus is desired, additional centrifugation can be performed after decanting the filtrate.

3.10.3 *Affinity Chromatography Concentration*

The application of the Matrex® Cellufine™ Sulfate columns for virus concentration allows efficient removal of endotoxins and other contaminants and should be used according to the manufacturer's recommendations.

1. The affinity matrix column is equilibrated with adsorption buffer (0.01 M phosphate, 0.1 M NaCl, pH 7.5) and samples are loaded at pH 7.5.
2. The column is washed with several bed volumes of adsorption buffer to remove nonbinding contaminants and the concentrated virus is eluted with elution buffer (1–2 M NaCl or KCl).

3.11 *Immunizations*

Alphavirus vectors have been applied in a number of immunization studies for vaccine development [7]. The immunization procedures obviously vary depending on whether the vectors are provided in the form of naked RNA, recombinant viral particles or layered DNA plasmids. Obviously, each vaccine target is unique and the methodology varies significantly depending on whether the aim is to develop a vaccine against pathogenic viruses or tumors. All methods cannot be presented here, so only a few examples are described.

3.11.1 *Immunization with RNA*

In the context of immunization with naked replicon RNA, *in vitro* transcribed RNA can be directly applied.

1. BALB/c mice are subjected to intramuscular injection of 100 µg of *in vitro* transcribed SFV-LacZ RNA [17].

2. Evaluation of immune response is monitored from sera by ELISA for the presence of IgG antibodies against recombinant β -galactosidase protein [27] 21 days post-injection.
3. In case of monitoring β -galactosidase-specific CD8⁺ T cell recognition splenocytes are isolated 21 days after immunization and re-stimulated in vitro for 6 days in the presence of the Ld-restricted peptide β -gal 876–884 (1 μ g/mL).

Tumor protection of mice immunized with in vitro transcribed RNA can be evaluated as follows.

3.11.2 Immunization with Recombinant Particles

1. Mice are subjected to intravenous injection of 5×10^5 CT26.CL25 tumor cells and evaluated 21 days post-immunization.
2. After 12 days, pulmonary metastases “blinded” to sample identity are counted.
3. In case of preestablished tumors, BALB/c mice are intravenously injected with 1×10^5 CT26.CL25 cells and tumors are grown for 2 days before immunization with 100 μ g SFV-LacZ RNA and assessed for survival.

VEE Particles in Mice

1. Recombinant alphavirus particles such as 10^6 VEE particles are diluted in PBS and injected subcutaneously into the plantar surface of each footpad of C57BL/6 mice three times at 2 weeks interval [28].
2. In case of tumor protection evaluation, vaccinated mice are challenged with 7.5×10^4 B16F10 tumor cells intradermally 2 weeks after immunization.
3. To address therapeutic efficacy, mice are first inoculated with 7.5×10^4 B16F10 tumor cells (either intradermally or intravenously) before subjected to 3 weekly vaccinations with VEE particles.

VEE Particles in Macaques

1. In the case of vaccine development against Ebola virus naïve cynomolgus macaques are intramuscularly injected with 10^{10} VEE-EBOV GP focus forming units (FFUs) in the quadriceps muscle [14].
2. Vaccinated animals are challenged intramuscularly and intranasally with approximately 1000 PFU of Ebola virus and monitored closely for at least 28 days.

3.11.3 Immunization with DNA

DNA Immunization of C57BL/6 Mice

1. Immunization with 3 μ g layered plasmid DNA vectors is conducted in C57BL/6 mice by 5 weekly intramuscular injections, which could be enhanced by plasmid-coated gold particles applying gene gun technology [29].

DNA Immunization of BALB/c Mice

2. One week after the last immunization mice are inoculated with 1×10^5 B16F10 tumor cells and tumor growth is monitored for at least 3 weeks.
1. In the case of viral targets SFV plasmid DNA vectors expressing membrane proteins PrM and E of Murray Valley encephalitis virus (MVE) are diluted in saline to a concentration of 1 mg/mL and 100–125 mg DNA doses are intramuscularly injected into BALB/c mice [30].
 2. Immunized mice are challenged intraperitoneally with 1.3×10^8 PFU of MVE and observed for 21 days for signs of encephalitis. Alternatively, SPF mice are intramuscularly immunized with 100 mg DNA into multiple sites on the hind leg muscles and boosted after 21 days.
 3. Two weeks after the final immunization, mice are intracranially challenged with 1000 TCID₅₀ of MVE and monitored for signs of encephalitis for 21 days.

4 Notes

1. It is essential to prepare plasmid DNA of high purity as it will enhance both quality and quantity of in vitro transcribed RNA directly used for immunization or for generation of high-titer recombinant virus stocks (Subheading 3.1).
2. Maximal in vitro transcription yields are achieved by using optimized CAP analogue $m^7G(5')ppp(5')G$ concentration and appropriate transcription buffer. Particular attention should be addressed for commercial buffers as the quality of generated RNA is not always compatible with high virus titer yields (Subheading 3.3).
3. The length of the gene of interest introduced into the expression vector might affect the RNA yields. When inserts exceed 4 kb RNA, yields might be improved by extending the incubation time for the in vitro transcription reaction (Subheading 3.3).
4. Recombinant virus stocks can be further purified by ultracentrifugation or affinity column purification methods (Subheading 3.10).

References

1. Delrue I, Verzele D, Madder A, Nauwynck HJ (2012) Inactivated virus vaccines: from chemistry to prophylaxis: merits, risks and challenges. *Expert Rev Vaccines* 11:695–719
2. Deng MP, Hu ZH, Wang HL, Deng F (2012) Developments of subunit and VLP vaccines against influenza A virus. *Virology* 27: 145–153
3. Liljestrom P, Garoff H (1991) A new generation of animal cell expression vectors based on the Semliki Forest virus replicon. *Biotechnology (NY)* 9:1356–1361

4. Xiong C, Levis R, Shen P, Schlesinger S, Rice CM, Huang HV (1989) Sindbis virus: an efficient, broad host range vector for gene expression in animal cells. *Science* 243: 1188–1191
5. Davies NL, Brown KW, Johnston RE (1989) In vitro synthesis of infectious Venezuelan equine encephalitis virus RNA from a cDNA clone: analysis of a viable deletion mutant. *Virology* 171:189–204
6. Lundstrom K (2003) Alphavirus vectors for vaccine production and gene therapy. *Expert Rev Vaccines* 2:447–459
7. Lundstrom K (2014) Alphavirus-based vaccines. *Viruses* 6:2392–2415
8. Brand D, Lemiale F, Turbica I, Buzelay L, Brunet S, Barin F (2000) Comparative analysis of humoral immune responses to HIV type 1 envelope glycoproteins in mice immunized with a DNA vaccine, recombinant Semliki Forest virus RNA, or recombinant Semliki Forest virus particles. *AIDS Res Hum Retroviruses* 14:1369–1377
9. Kirman JR, Turon T, Su H, Li A, Kraus C, Polo JM et al (2003) Enhanced immunogenicity to *Mycobacterium tuberculosis* by vaccination with an alphavirus plasmid replicon expressing antigen 85A. *Infect Immun* 71:575–579
10. Giraud A, Ataman-Onal Y, Battail N, Piga N, Brand D, Mandrand B et al (1999) Generation of monoclonal antibodies to native human immunodeficiency virus type 1 envelope glycoprotein by immunization of mice with naked RNA. *J Virol Methods* 79:75–84
11. Caley IJ, Betts MR, Irlbeck DM, Davis NL, Swanstrom R, Frelinger JA et al (1997) Humoral, mucosal, and cellular immunity in response to a human immunodeficiency virus type 1 immunogen expressed by a Venezuelan equine encephalitis virus vaccine vector. *J Virol* 71:3031–3038
12. Pushko P, Bray M, Ludwig GV, Parker M, Schmaljohn A, Sanchez A et al (2000) Recombinant RNA replicons derived from attenuated Venezuelan equine encephalitis virus protect guinea pigs and mice from Ebola hemorrhagic fever virus. *Vaccine* 19:142–153
13. Yang SG, Wo JE, Li MW, Mi FF, Yu CB, Lv GL et al (2009) Construction and cellular immune response induction of HA-based alphavirus replicon vaccines against human avian influenza (H5N1). *Vaccine* 27:7451–7458
14. Herbert AS, Kuehne AI, Barth JF, Ortiz RA, Nichols DK, Zak SE et al (2013) Venezuelan equine encephalitis virus replicon particle vaccine protects nonhuman primates from intramuscular and aerosol challenge with Ebolavirus. *J Virol* 87:4952–4964
15. Moran TP, Burgents JE, Long B, Ferrer I, Jaffee EM, Tisch RM et al (2007) Alphaviral vector-transduced dendritic cells are successful therapeutic vaccines against neu-overexpressing tumors in wild-type mice. *Vaccine* 25: 6604–6612
16. Lachman LB, Rao XM, Kremer RH, Ozpolat B, Kiriakova G, Price JE (2001) DNA vaccination against neu reduces breast cancer incidence and metastasis in mice. *Cancer Gene Ther* 8:259–268
17. Ying H, Zaks TZ, Wang RF, Irvine KR, Kammula US, Marincola FM et al (1999) Cancer therapy using a self-replicating RNA vaccine. *Nat Med* 5:823–827
18. Hart MK, Caswell-Stephan K, Bakken R, Tammariello R, Pratt W, Davis N et al (2000) Improved mucosal protection against Venezuelan equine encephalitis virus is induced by the molecularly defined, live-attenuated V3526 vaccine candidate. *Vaccine* 18: 3067–3075
19. Mallilankaraman K, Shedlock DJ, Bao H, Kawalekar OU et al (2011) A DNA vaccine against chikungunya virus is protective in mice and induces neutralizing antibodies in mice and nonhuman primates. *PLoS Negl Trop Dis* 5, e928
20. Edelman R, Tacket CO, Wasserman SS, Bodison SA, Perry JG, Mangiafico JA (2000) Phase II safety and immunogenicity study of live chikungunya virus vaccine TSI-GSD-218. *Am J Trop Med Hyg* 62:681–685
21. Bernstein DI, Reap EA, Katen K, Watson A, Smith K, Norberg P et al (2009) Randomized, double-blind, Phase I trial of an alphavirus replicon vaccine for cytomegalovirus in CMV seronegative adult volunteers. *Vaccine* 28:484–493
22. Morse MA, Hobeika AC, Osada T, Berglund P, Hubby B, Negri S et al (2010) An alphavirus vector overcomes the presence of neutralizing antibodies and elevated numbers of Tregs to induce immune responses in humans with advanced cancer. *J Clin Invest* 120: 3234–3241
23. Slovin SF, Kehoe M, Durso R, Fernandez C, Olson W, Gao JP et al (2013) A phase I dose escalation trial of vaccine replicon particles (VRP) expressing prostate-specific membrane antigen (PSMA) in subjects with prostate cancer. *Vaccine* 31:943–949

24. Sjöberg EM, Suomalainen M, Garoff H (1994) A significantly improved Semliki Forest virus expression system based on translation enhancer segments from the viral capsid gene. *Biotechnology* 12:1127–1131
25. Lundstrom K, Abenavoli A, Malgaroli A, Ehrengreuber MU (2003) Novel Semliki Forest virus vectors with reduced toxicity and temperature-sensitivity for long-term enhancement of transgene expression. *Mol Ther* 7:202–209
26. Berglund P, Sjöberg M, Garoff H, Atkins GJ, Sheahan BJ, Liljestrom P (1993) Semliki forest virus expression system: production of conditionally infectious recombinant particles. *Biotechnology* 11:916–920
27. Irvine KR, Rao JB, Rosenberg SA, Restifo NP (1996) Cytokine enhancement of DNA immunization leads to effective treatment of established pulmonary metastases. *J Immunol* 156:238–245
28. Avogadri F, Merghoub T, Maughan MF, Hirschhorn-Cymerman D et al (2010) Alphavirus replicon particles expressing TRP-2 provide potent therapeutic effect on melanoma through activation of humoral and cellular immunity. *PLoS One* 5, e12670
29. Reitner WW, Hwang NL, de Veer MJ, Zhou A, Silverman RH, Williams BRG et al (2003) Alphavirus-based DNA vaccine breaks immunological tolerance by activating innate antiviral pathways. *Nat Med* 5:33–39
30. Colombage G, Hall R, Pavy M, Lobigs M (1998) DNA-based and alphavirus-vectored immunization with PrM and E proteins elicits long-lived and protective immunity against the flavivirus, Murray Valley encephalitis virus. *Virology* 250:151–163

Vaccine Design: Replication-Defective Adenovirus Vectors

Xiangyang Zhou, Zhiquan Xiang, and Hildegund C.J. Ertl

1 Introduction

Replication-defective adenovirus (Ad) vectors based on human or simian serotypes are being developed as vaccine carriers for a large number on pathogens or cancers [1–14]. Several features render Ad vectors highly attractive as vaccine carriers. They induce potent adaptive immune responses to transgene products [15]. Ad vectors similar to wild-type Ads persist at low levels in activated T cells in a transcriptionally active form, which results in very sustained immune responses [16]. Through deletions of the E1 domain Ad vectors can be rendered replication-defective. In addition, deletion of E1 reduces transcription of Ad antigens without affecting transcription of the transgene, which is typically under the control of a ubiquitously active, strong promoter such as the cytomegalovirus (CMV) early promoter. This in turn allows immune response to focus on the transgene product rather than on Ad antigens. Ad vectors are relatively easy to generate [16], packaging cell lines are available for many serotypes, yields upon propagation suffice for clinical development, and procedures for production and release testing under good manufacturing practice (GMP) are available. Clinical experience has shown that E1-deleted Ad vectors given at immunogenic doses are well tolerated by humans [4, 14].

The 35–40 kb genome of several serotypes of Ad has been cloned into plasmid vectors, which allows for modifications of the genome including excision of domains that are essential for viral replication, such as the E1 domain, or regions that are nonessential such as E3. Replacing the deleted E1 domain with sites for rare restriction enzymes then allows for easy insertion of an for expression of a foreign antigen. The permitted size for inserted sequences depends on the type of deletion. E1-only deleted adenovirus vectors can accommodate ~4 kp, and additional deletion in E3 allows for insertion of ~7.5 kb of foreign sequences.

We previously described procedures to develop viral molecular clones of Ad genomes [16]. This chapter offers a description of generating and quality controlling recombinant Ad vectors from already available viral molecular clones. The focus is on generation of E1-deleted Ad vectors, in which the foreign expression cassette is inserted into E1. Specifically, generation of recombinant pShuttle vectors for E1 is described followed by procedures to clone the expression cassette from pShuttle into the viral molecular clone. Virus is then rescued, expanded, and purified. Methods are provided for quality control of Ad vectors including titration, testing for genetic integrity and stability, assessing potential contaminations with replication-competent Ad, and levels of transgene product expression. Additional processes needed to release clinical lots are not addressed.

1.1 Generation of pShuttle Vectors with New Transgenes

pShuttle vectors for insertion of an expression cassette into an Ad molecular clone, in which the deleted E1 domain is replaced by restriction enzyme sites for I-CeuI and PI-SceI, are available from Clontech and other vendors. This vector has a pUC origin, a kanamycin resistance gene, an expression cassette with a multicloning site (MCS) flanked by the CMV immediate early promoter, including enhancer and TATA box and a bovine growth hormone (BGH) polyadenylation signal. The expression cassette is bordered by sites for I-CeuI and PI-SceI restriction enzymes. The vector is expanded in competent cells of an *E. coli* strain, such as DH5 α . A transformed bacterial clone is selected and expanded. Aliquots of the transformed bacteria are cryopreserved. Plasmid DNA is purified from the remaining bacteria and quantified.

The next step is preparation of the sequence for insertion into pShuttle. The sequence can either be derived from another plasmid vector, directly from a pathogen, by polymerase chain reaction (PCR) amplification of a pathogen's genome or upon reverse transcription of a pathogen's transcript. In some cases it is beneficial to produce an artificial gene by synthesis of the coding sequence. This is particularly useful if the pathogen or sequences thereof are not readily available. It also allows for codon-optimization of sequences, which achieves in general higher levels of protein expression compared to wild-type sequences. The coding sequence requires a start codon, as this is not present in pShuttle. The MCS of pShuttle has three stop codons; nevertheless, depending on which enzymes sites are used for insertion of the transgene, these sequences may be deleted. Therefore, use transgenes that contain both start and stop codons. The following enzymes can be used for ligation of the transgene into pShuttle: BglII, NotI, ScaI, NheI, SpeI, EcoRV, PvuI, SalI, SrfI, and XhoI. ScaI and EcoRV are blunt end cutters and can be used if the insert is not flanked by enzymes sites compatible with those of pShuttle's MCS.

The next step depends on the origin of the insert sequence. If the sequence can be cut from an already available vector, if possible, use two different restriction enzymes for excision of the genes that also have sites in the correct order in the MCS of pShuttle. The original vector is cut with restriction enzymes following the manufacturers' instructions. Upon digestion the fragment is separated from the vector backbone by gel electrophoresis, purified, and quantified. If the same enzymes that are used to excise the fragment can be used to cut the MCS of pShuttle, the fragment is now ready for ligation. If different enzymes are used the fragment should be blunt ended by a fill in reaction with Klenow fragment of DNA polymerase. This enzyme exhibits 5' to 3' polymerase and 3' to 5' exonuclease activities. However, the 3' to 5' exonuclease function of Klenow is comparatively weak. Therefore use T4 DNA polymerase to blunt 3' overhangs. If the fragment is produced by PCR, use oligonucleotide primers for amplification, which carry the desired restriction enzymes; during synthesis of artificial genes, it is necessary to ensure such sequences are introduced at 5' and 3' ends of the coding sequence. In either case the sequence is cut with restriction enzymes and then either purified by gel electrophoresis or enzymes are inactivated by high temperature. Once the insert is cut and purified, determine concentration. In parallel, prepare the pShuttle vector. The vector is digested with enzymes that target the MCS. The enzyme used largely depends on the insert. If possible, use two enzyme sites to avoid insertion in the wrong orientation. If enzyme sites do not match, cut the pShuttle with one of the two blunt-end cutters, i.e., ScaI or EcoRV. Alternatively, if only one end between pShuttle and the insert is compatible, it is possible to digest this with one enzyme. In either case, vectors are then treated with phosphatase to prevent self-ligation. Use of phosphatase or cutting with two enzymes that generate non-compatible ends is desirable to prevent high background due to vectors that religate without insert enzymes. After phosphatase treatment, pShuttle is checked by gel electrophoresis against an aliquot of uncut pShuttle to ensure complete digestion. Completely digested vector is then purified.

Both the pShuttle vector and the insert are now ready for ligation. A reaction containing cut pShuttle without insert is included. The ligated plasmid is then transfected into *E. coli* strain DH5 α . Plasmid carrying bacteria are expanded on LB agarose plates with kanamycin. Bacteria transformed with pShuttle without insert should yield no or only a few colonies. Colonies from the pShuttle-insert ligation are selected and expanded, the plasmid DNA is purified, cut with restriction enzymes, and separated by gel electrophoresis; the gel is checked under UV light to ensure that

an insert of the expected size is present in the correct orientation. Once this is confirmed, aliquots of the transformed bacteria are cryopreserved; the rest is expanded. The plasmid is then again purified. As a rule, to guard against flawed constructs, sequence part of the newly generated pShuttle vector emphasizing sequences that flank the ligation sites.

1.2 Generation of a Recombinant Viral Molecular Clone

Viral molecular clones for Ad of human serotype 5 (HAdV-5) are available from Clontech. Molecular clones for other serotypes have been generated by investigators in academia, who as a rule share such clones under material transfer agreements. It is important to obtain the entire nucleotide sequence of an Ad molecular clone for this is needed to characterize the DNA of recombinant virus. Viral molecular clones are large (>30 kb) and have to be treated gently; be careful to not break the DNA by vigorous pipetting or shaking. Once the viral molecular clone is expanded in a strain of *E. coli* that can accommodate large plasmids, purified, and quantified, it is cut with the rare recognition site enzymes I-CeuI and PI-SceI. The recombinant pShuttle is cut with the same enzymes to release the expression cassette including the insert. After purification of the cut viral molecular clone and the insert, both pieces are combined by ligation. The recombinant viral molecular clone is then transformed into bacteria. Upon expansion the molecular clone is purified. After visualizing the purified and quantified plasmid by gel electrophoresis two methods are used to ensure that the correct sequence is obtained. First two sets of restriction enzymes are used: one set that cuts within the insert and within the backbone, one set that cuts 3' and 5' from the insert. Again considering the size of the viral molecular clone, enzymes should be selected carefully; they should yield at least four to six bands but no more than 10–12 to allow for good resolution upon gel electrophoresis. Also, the digestion needs to be complete; incomplete digestion yields additional bands, which make it very hard to interpret the results (*see Note 1*). Once the anticipated banding pattern is confirmed, sequence part of the viral molecular clone, focusing on the insertion site.

1.3 Viral Rescue

Ad vectors are rescued in cells that provide Ad E1 in trans. Cells with the E1 of HAdV-5, such as HEK 293 cells, are available from ATCC (ATCC® Number: CRL-1573™). The E1 in HEK 293 cells not only transcomplements the deletion of HAdV-5 vectors but also of other human or simian serotype vectors. Nevertheless, it is not suited for some Ad serotypes. For these, new packaging cell lines based on mammalian cells that can readily be infected with Ad need to be developed. For viral rescue the linearized viral molecular clone is transfected into HEK 293 cells. In general it takes 5–7 days till viral plaques become visible. Once at least half of the cell monolayer is destroyed, cells are harvested and virus is released from the cell pellet by freeze-thawing. Virus is then gradually expanded in HEK 293 cells (*see Note 2*).

1.4 Vector Purification

Once virus is expanded and released from cells by freeze-thawing, the solution is cleared from cell debris by low-speed centrifugation. The cleared supernatant is then subjected to CsCl gradient ultracentrifugation. Upon centrifugation three bands should become visible. The band on top reflects residual cell debris, the middle band is formed by defective viral particles (vps), and the lower band contains intact vps. The lower band is harvested and further purified by gel chromatography. Purified vector is then aliquoted and stored in a $-70\text{ }^{\circ}\text{C}$ freezer. Use one CsCl gradient step. For better purity a second gradient can be added; however, in our experience this results in a significant loss in viral yields and increases in vp to infectious units (IU) ratios. Store the virus in PBS + 10 % glycerol. Other buffers may yield better thermostability at $4\text{ }^{\circ}\text{C}$ or at room temperature. If increased stability is warranted, alternative buffers must be tested. The ideal buffer for each serotype needs to be established experimentally through stability testing at different temperatures. For these assays a working dilution of Ad vectors (i.e., 10^{10} vp/ml) should be used, as high concentrations of vectors tend to increase thermostability (*see Note 3*).

1.5 Vector Titration

The vp content is determined by spectrophotometry at 260 and 280 nm. The OD_{260} is used to determine vp using the formula: $\text{OD}_{260} \times \text{dilution} \times 1.1 \times 10^{12}$. The ratio of OD_{260} over OD_{280} reflects purity and should be close to 1.3. The expected yield of vp from large batches of Ad vectors (40 T175 flasks) ranges from 10^{13} to 10^{14} vp. Several methods are available to determine content of IU. Plaque assays are suitable for viruses that yield distinctive cytopathology; they are not useful for some of the simian Ads. A staining method for hexon of HAdV-5 virus is available. Use a nested PCR based on hexon-specific primers. For this method, virus is serially diluted according to vps. Typically, cells are infected with 10, 100, 1000, and 10,000 vps/well. Cells are harvested 7 days later; RNA is isolated and reverse-transcribed. The cDNA is then amplified by a nested PCR against a positive control (e.g., the viral molecular clone) and uninfected HEK 293 cells as a negative control. Amplicons are visualized by gel electrophoresis and number of positive wells at a given dilution is used to determine the IU titer. Typically used are two dilutions that yield amplicons in less than 100 % of the wells. For example: at 100 vp 8/10 wells are positive, titer [% positive wells: 50] = 1.6 IU in 100vp; at 10vp 2/10 wells are positive; titer [% positive wells: 50] = 0.4 IU in 10 vps or 4 IU in 100 vp. Then use the average (in our example 2.8 IU in 100vp) to determine IU titer and calculate vp to IU ratio (in this example 35.7:1). Typically vp to IU ratios are below 100:1 although this depends on the Ad serotype and on the type of the insert. In our experiments, HAdV-5 vectors in general yield lower vp to IU ratios than simian Ad vectors; expression cassettes that encode very long or toxic proteins tend to yield higher vp to IU

ratios. It is common to see that the first viral expansion, which is based on untitrated viral stocks, yields higher vp to IU ratios than subsequent expansions, which are based on expansion of vectors that already have been titrated. Therefore, use virus from the first virus expansion after some initial control studies mainly as a master virus bank (MVB). All subsequent virus batches are derived from this MVB. Once the MVB has been depleted, re-rescue the virus. For a second expansion, use 0.5–1 IU to infect each HEK 293 cell. Of note: Procedures for virus expansion have to be optimized for Ad vectors based on different serotypes by trial and error. Some vectors can be expanded in suspension cells without fetal bovine serum (FBS); others give better yields when grown on monolayer cells with FBS. The optimal infection dose for expansion varies depending on the type of the vector. The best time to harvest cells after infection also varies and depends in part on the dose used for infection. The fetal calf serum has to be screened as some batches interfere with vector replication. HEK 293 cells have to be used at a low passage number as upon passaging cells apparently lose E1 and then only poorly support growth of E1-deleted Ad vectors (*see Note 4*).

1.6 Vector Quality Control

Conduct a number of quality control studies once the vector is purified and titrated to ensure that the viral rescue resulted in a vector with the expected characteristics.

1.6.1 Genetic Integrity

First ensure integrity of the viral genome to spot possible rearrangements or loss of transgene. For this, DNA is purified from 5×10^{12} vp of vector using a DNA purification kit according to the manufacturer's instruction. The purified DNA is cut separately with two enzymes; use the same enzymes that are used for characterization of the viral molecular clone. Upon complete digestion, the bands are visualized by gel electrophoresis. Provided the correct banding pattern is obtained, next determine expression of the transgene (*see Note 5*).

1.6.2 Transgene Expression

HEK 293 cells (1.2×10^6 /well per well) plated in 6-well plates are infected with 10^9 or 10^{10} vp of vector. Two days later the cells are harvested. If the vaccine antigen is secreted, one may harvest supernatant, which can be concentrated by various methods such as precipitation or lyophilization. If antibodies are available, perform Western blots. If antibodies detect conformation dependent epitopes, use immunoprecipitation. For surface expressed antigens, fluorochrome-labeled antibodies followed by flow cytometry may be used. If no antibodies are available, design the insert to express a flag-tag and then use antibodies against the tag. If this is not an option, reverse-transcribe the RNA and use a real-time PCR to quantify insert-specific transcripts. The latter is not ideal as it fails to determine if a protein of the expected size is expressed (*see Note 6*).

1.6.3 Endotoxin Levels

Once protein expression has been confirmed, determine endotoxin content using a commercially available kit for vector batches that are to be tested in animals.

1.6.4 Content of Replication-Competent Adenovirus

For AdHV-5 vectors expanded in HEK 293 cells, test for presence of replication-competent Ad (RCA), which can arise due to homologous recombination between the E1-flanking region in the Ad vector and the E1 present in HEK 293 cells. As E1-flanking sequences between different serotypes of Ad are not homologous, this assay for simian Ads grown in HEK 293 cells is not routinely conducted. The assay is based on plaque formation in cells that lack E1 such as A549 cells. The assay is conducted in six-well plates using serial dilutions of the vector. Wild-type Ad is used as a positive control. To ensure that the vector preparation does not interfere with plaque formation additional wells are cultured with wild-type virus mixed with serial dilutions of Ad vectors. Cells are screened under a microscope for viral plaques 4–8 days later.

1.6.5 Genetic Stability

Ad vectors, which are generated as precursors for clinical development, should be tested for genetic stability upon serial passages (*see Note 7*). This is achieved by serially passaging virus from the MVB 12 times in 2 daily intervals in HEK 293 cells. After the 12th passage the virus is expanded which takes another three passages. Virus is then purified, and vp content is measured. Vector DNA is isolated and tested by the two sets of restriction enzymes used to characterize the MVB. DNA from the MVB serves as a positive control. The banding pattern of the genome obtained after 15 passages should be identical to that of the genome of early passage vector [*see Note 8*].

2 Materials

2.1 Generation of pShuttle Vectors with New Transgenes

1. pShuttle vector for Ad vectors.
2. Competent DH5 α cells.
3. LB medium.
4. LB medium with kanamycin (50 $\mu\text{g}/\text{ml}$).
5. Agarose plates with kanamycin (50 $\mu\text{g}/\text{ml}$).
6. TE buffer.
7. Qiagen Plasmid Mini Kit.
8. Qiagen Plasmid Midi Kit.
9. DNA purification kit.
10. 1 % agarose gel in TAE buffer: 10 \times stock solution: 48.4 g of Tris base, 3.72 g disodium EDTA, adjusted to pH 8.5, with 0.5 $\mu\text{g}/\text{ml}$ of ethidium bromide, molecular weight marker.

11. Sterile glycerol.
12. Cryovials, -70 °C freezer.
13. 37 °C incubator, 37 °C shaker.
14. Gel electrophoresis system with power source.
15. Gel documentation system.
16. Eppendorf centrifuge (used in these experiments: 5810R; 5415D [g calculated using Eppendorf website: <http://www.eppendorf.com/int/index.php?l=1&action=products&contentid=169>]).
17. UV spectrophotometer.
18. Enzymes: restriction enzymes, e.g., BglII, NotI, ScaI, NheI, SpeI, EcoRV, PvuI, Sal I, SrfI, and/or XhoI.
19. Alkaline phosphatase.
20. T4 DNA ligase.

2.2 Generation of New Recombinant Molecular Viral Clones

1. Adenoviral molecular clone, e.g., pAdEasy-1 vector (Agilent).
2. Vector map.
3. Software (Vector NTI®).
4. Competent cells of *E. coli* strain Stbl2 (Invitrogen).
5. Agarose plates and LB broth with ampicillin (100 mg/l).
6. I-CeuI and PI-SceI restriction enzymes.
7. T4 DNA ligase.
8. 1 % agarose gel with ethidium bromide and molecular weight marker.
9. DNA purification kit.
10. Qiagen Plasmid Mini/Midi Kits.
11. Endofree Qiagen Plasmid Maxi Kit.

2.3 Viral Rescue and Expansion

1. HEK 293 cells.
2. DMEM medium with 1 % glutamine. 1 % Pen/Step, without or with 5 % FBS.
3. T25 flasks.
4. T175 flasks.
5. Six-well plates.
6. 5, 15, 50 ml plastic tubes.
7. 37 °C incubator with 5 % CO₂.
8. Inverted microscope.
9. Restriction enzyme Pac I.
10. Reagents for transfection (e.g., CaCl₂, Lipofectin, or others).

12. Serum-free HEK 293 medium: DEME with glutamine and antibiotics.
13. Regular growth medium: DMEM with glutamine, antibiotic, and 5 % FBS.

2.4 Vector Purification

1. CsCl at 1.2 g/ml and 1.45 g/ml in 10 mm Tris buffer.
2. Refrigerated centrifuge.
3. Ultracentrifuge.
4. SW32 rotor.
5. Ultracentrifuge tubes.
6. Liquid chromatography column.
7. Bio-Gel P polyacrylamide gel.
8. PBS with a final concentration of 10 % glycerol.

2.5 Vector Titration

1. UV spectrophotometer.
2. Nested PCR primers, e.g., for hexon, one set should result in 500–600 bp amplicon, 2nd set in 200–300 bp amplicon.
3. PCR machine.
4. Primers shown are suitable for titration of vectors derived from HAdV-5: first PCR, forward primer: 5'- ATCATGCAGCTGG GAGAGTC-3', reverse primer: 5'- ACACCTCCCAGTGGAAA GCA-3'; nested PCR, forward primer: 5'- GACTCCTAAAGT GGTATTGT-3', reverse primer: 5'- GTCTTGCAAATCTACA ACAG-3'.
5. Tri-Reagent.
6. SuperScript One-Step RT-PCR with Platinum Taq kit.
7. Illustra™ puReTaq Ready-To-Go PCR Beads.
8. 1 % agarose gel, ethidium bromide and molecular weight markers.
9. Gel electrophoresis apparatus with power source.
10. Gel documentation system.

2.6 Vector Quality Control

1. Vector map, Software (Vector NTI®).
2. DNA isolation kit.
3. Restriction enzymes with buffer.
4. 1 % agarose gel, ethidium bromide, and molecular weight markers.
5. Gel electrophoresis apparatus with power source.
6. Gel documentation system.
7. HEK 293 cells.
8. A549 cells.

9. DMEM growth medium.
10. T25 flasks.
11. T175 flasks.
12. Six-well plates.
13. 5, 15, and 50 ml plastic tubes.
14. Endotoxin kit.
15. Wild-type Ad virus.
16. 37 °C incubator
17. Inverted microscope.
18. 2 % Seahorse agarose solution in H₂O: 2× culture medium, 10 % fetal calf serum, placed in 37 °C water bath.

3 Methods

3.1 Generation of pShuttle Vectors with New Transgenes

3.1.1 Expansion of pShuttle

1. Add 40 ng of pShuttle diluted in 1× TE buffer to 250 µl of competent *E. coli* cells, strain DH5α.
2. Incubate for 30 min on ice.
3. Heat-shock for 2 min at 42 °C.
4. Add 1 ml of LB medium and incubate for 1 h at 37 °C under gentle agitation.
5. Plate on agarose plate with kanamycin (50 µg/ml).
6. Incubate overnight at 37 °C.
7. Select individual colonies.
8. Expand overnight in 3.5 ml of LB medium with kanamycin at 37 °C on a shaker.
9. Pellet bacteria from 1.5 ml, and save 2 ml of the suspension cultures.
10. Isolate plasmid DNA from the cell pellets with Qiagen Plasmid Mini Kit.
11. Run an aliquot of the DNA on a 1 % agarose gel with 0.5 µg/ml of ethidium bromide; include a molecular weight marker.
12. Visualize band under UV; pShuttle should give a band at ~4.2 kb + size of insert.
13. Expand remaining 2 ml of transformed bacteria in 100 ml of LB with kanamycin for 14–18 h at 37 °C on a shaker.
14. Freeze down an aliquot of the bacteria upon mixing bacterial suspension with glycerol to a final concentration of 20 % glycerol, and store bacterial stocks in cryovials in a –70 °C freezer.
15. Purify plasmid DNA from expanded bacteria by Qiagen Plasmid Midi Kit.

16. Run aliquot on a 1 % agarose gel with ethidium bromide; the expected size of the band is same as above.
17. Quantify DNA by UV spectrophotometry at 260 nm.
18. Calculate DNA quantity (optical density [OD] of 1 at 260 nm = approximately 1 µg/µl of DNA).

3.1.2 Preparation of the Insert

Insert derived from another vector with matching restriction sites

1. Expand and purify vector as described in Subheading 3.1.1.
2. Excise gene of interest, preferentially by cutting with BglII, NotI, ScaI, NheI, SpeI, EcoRV, PvuI, SalI, SrfI, and/or XhoI.
3. Preferentially use two enzymes but ensure that the direction of the two enzyme sites are identical to those in the MSC of pShuttle.
4. Run digested plasmid on a 1 % low-melt agarose gel with ethidium bromide together with a molecular weight marker.
5. Excise fragment from the gel with a scalpel.
6. Place fragment into Eppendorf tube and melt for 5 min at 65 °C, and add buffer.
7. Purify by a DNA purification kit.
8. Quantify DNA by spectrophotometry.

Insert derived from another vector with non-matching restriction sites.

1. After excising the fragment from the gel treat with Klenow fragment (1 U/1 µg of DNA) for 30 min at room temperature.
2. Stop reaction by incubation for 20 min at 65 °C.

Insert derived from PCR product

1. Use primers that add suitable restriction enzymes to the 5' and 3' end of the sequence.
2. Purify amplicon by gel electrophoresis.
3. Excise amplicon from gel following the procedures described above.
4. Cut amplicon with the restriction enzymes and then proceed as described above.

Insert derived from synthetic sequence

1. Ensure that suitable restriction enzyme sites are placed at 5' and 3' ends of the sequence.
2. Proceed as described above.

3.1.3 Preparation of pShuttle

1. Cut pShuttle with the appropriate restriction enzymes matching those used for the insert.
2. Alternatively cut pShuttle with a blunt end cutter, e.g., EcoRV.

3. Purify digested pShuttle by DNA purification kit.
4. Incubate with alkaline phosphatase for 20 min at 37 °C for 5' overhangs or for 1 h at 37 °C for blunt ends or 3' overhangs.
5. Run aliquot of digested pShuttle vector on a 1 % agarose gel with ethidium bromide.

3.1.4 Cloning of the Insert into pShuttle

1. Mix 75 ng of insert and 25 ng of pShuttle with 1 U of T4 ligase in ligation buffer.
2. In a 2nd reaction incubate 25 ng of pShuttle with T4 DNA ligase, this reaction should yield no or only few colonies.
3. Incubate at 16 °C for 16–18 h.
4. Transform into competent *E. coli* DH5 α as described above, select and expand colonies, purify DNA as described above.
5. Cut purified plasmid DNA with suitable restriction enzymes.
6. Run on 1 % agarose gel with ethidium bromide.
7. Under UV light bands of the expected size should become visible.
8. Expand plasmid positive bacteria in LB broth with kanamycin.
9. Freeze down aliquot of bacteria.
10. Purify plasmid DNA with Qiagen Plasmid Midi Kit.
11. Quantify DNA by UV spectrometry.
12. Not essential but prudent: sequence the insertion sites of the plasmid vector.

3.2 Generation of New Recombinant Molecular Viral Clones

3.2.1 Preparation of the Viral Molecular Clone

1. Transform competent cells of *E. coli* strain Stbl2 with the plasmid containing the viral molecular clone.
2. Select transformed bacteria, expand bacteria, and purify plasmid DNA as described above but use ampicillin (100 μ g/ml) rather than kanamycin for selection.

3.2.2 Ligation of the Insert into the Viral Molecular Clone

1. Cut ~1 μ g of pShuttle with I-CeuI and PI-SceI restriction enzymes.
2. Cut ~2 μ g of the molecular viral with I-CeuI and PI-SceI restriction enzymes.
3. Run aliquots of both digests on 1 % agarose gels with ethidium bromide.
4. If digest is complete purify the insert from pShuttle by gel electrophoresis as described above; purify the digested molecular viral clone using a DNA purification kit.
5. Quantify DNA by UV spectrophotometry.

6. Mix 75 ng of the insert and 25 ng of the viral molecular clone with 1 U of T4 ligase.
7. Proceed as described above but use competent Stbl2 cells and medium containing ampicillin for expansion of the viral molecular clones.
8. Grow up ~100 ml of transformed bacteria.
9. Purify the DNA from pelleted bacteria using the Qiagen Plasmid Midi Kit.
10. Use an aliquot for digestion with I-CeuI and PI-SceI to ensure the insert is still present.
11. Use an aliquot of the DNA for sequencing of the insert including the insert's flanking regions [*see* **Note 1**].

3.3 Viral Rescue and Expansion

3.3.1 Transfection of Packaging Cells (e.g., HEK 293 Cells)

1. Plate 2×10^6 HEK 293 cells at a low passaging number (<60) in a T25 flask.
2. Check cells the following day, they should be 70–80% confluent.
3. Digest 5 μ g of the recombinant viral molecular clone with Pac I to linearize the plasmid.
4. Prepare the transfection mixture: 300 μ l of $2 \times$ DMEM medium with an equal volume of a mixture that contains 37 μ l of 2M CaCl_2 and the digested plasmid, incubate for 30 min at room temperature.
5. During incubation replace the cell culture medium with serum-free HEK 293.
6. Add vector- CaCl_2 mixture slowly to the cells.
7. Incubate overnight at 37 °C in a 5% CO_2 incubator.
8. The next day replace the vector-containing medium with 5 ml of regular growth medium.
9. Incubate flask for 3–4 days at 37 °C, 5 % CO_2 .
10. Thereafter, add 1 ml of fresh growth medium every second day.
11. Start checking for viral plaques daily by day 5 after transfection.
12. Once viral plaques have destroyed 30–50% of the cell monolayer, shake flasks vigorously to remove cells adherent to the plastic.
13. Collect cells and spin down for 10 min at $900 \times g$ in a refrigerated centrifuge.
14. Discard supernatant and resuspend cell pellet in 1 ml of HEK 293 growth medium without serum.
15. Freeze cells on dry ice and thaw in 37 °C water bath. Repeat twice.
16. Pellet cell debris by centrifugation in an Eppendorf tube (*see* **Note 2**).

3.3.2 Expansion of Vectors in HEK 293 Cells

1. Use about 1/2 of the supernatant to infect a fresh T25 flask of HEK 293 cells (~70 % confluent).
2. Remove FBS prior to infection.
3. Replace the virus-containing medium with fresh medium +5 % FBS after a 1–2 h incubation period at 37 °C.
4. Check cells daily for viral plaques, harvest cells once plaques have destroyed at least 30 % of the monolayer and release virus by freeze-thawing of cell pellets as described above.
5. Use most of the virus solution to infect 3 T175 flasks of HEK 293 cells.
6. Harvest cells 24–72 h later depending on the degree of cytopathic effects (CPE).
7. Release virus by freeze-thawing as described above and use most of the resultant solution to infect 40 T175 flasks of HEK 293 cells.
8. Harvest cells once viral CPEs have destroyed most of the monolayer (typically within 48–72 h).
9. Release virus by freeze-thawing, the last thaw should not be conducted till everything is ready for vector purification.

3.4 Vector Purification

3.4.1 Removal of Cell Debris

1. Place cell suspension in 50 ml sterile plastic tube and centrifuge at 4 °C at 1800 × *g* for 25 min.
2. Collect virus-containing supernatant.

3.4.2 Gradient Centrifugation on CsCl Gradient

1. Place 4 ml of 1.45 g/ml CsCl into Ultra-Clear Beckman centrifuge tubes, overlay with 2 ml of 1.2 g/ml CsCl, and add 8 ml of cleared virus containing supernatant.
2. Prepare balance tube with identical weight (difference in weight has to be <0.05 g).
3. Place tubes in SW27 rotor, spin at 100,000 × *g* at 4°C for 2 h, decelerate without brake.
4. Remove tubes and place into laminar flow hood; three bands should be visible: the band on top is residual cell debris, the middle band contains defective vps, and the lower band contains intact vps.
5. Harvest the lower band with a syringe and needle, carefully piercing the centrifuge tube just below the lower band (*see Note 3*).

3.4.3 Removal of CsCl

1. Fill 5 ml of Bio-gel in 10 mm Tris buffer, pH 8.0 from Bio-Rad into a column.
2. Add the flu2id collected from the CsCl gradient to the column.

3. Stepwise add 0.5 ml of PBS (~10 times) and harvest each eluate.
4. Eluates that are milky contain virus; save and pool these.
5. Measure vp content (see next paragraph).
6. Dilute to 10^{12} vp per ml in buffer.
7. Label cryotubes, aliquot vector, and freeze down at -70°C .

3.5 Vector Titration

3.5.1 VP Content

1. Dilute virus at 1:10, place 1 ml of virus into cuvette, and measure OD at 260 and 280 nm.
2. Calculate vp based on OD_{260} using the formula: $\text{OD}_{260} \times \text{dilution} \times 1.1 \times 10^{12}$.
3. Assess purity by ratio of $\text{OD}_{260}/\text{OD}_{280}$; this ratio should be close to 1.3.

3.5.2 IU Content of by PCR

1. Plate 2×10^5 HEK 293 cells in 2 ml of culture medium into wells of 6-well plates.
2. Incubate overnight at 37°C in a 5 % CO_2 incubator. Check the next day to ascertain cells are ~70–80% confluent.
3. Dilute vector in serum-free HEK 293 medium to 10^1 , 10^2 , 10^3 , and 10^4 vp. Prepare ~10 ml for each dilution.
4. Remove medium from HEK 293 cells and replace with 2 ml of the diluted virus. Set up at least 5 wells per dilution.
5. Incubate for 1 h at 37°C , then add 2 ml of culture medium to each well.
6. Incubate for 7 days at 37°C in a 5 % CO_2 incubator.
7. Remove most of the supernatant, use a scraper to remove the cells from the plastic, collect cells with a pipette into a 5 ml plastic tube.
8. Rinse cells with 1 ml of medium to collect residual cells, pellet cells by centrifugation at $1800 \times g$ for 5 min.
9. Isolate RNA from cell pellet by adding 1 ml/well of Tri reagent (Sigma).
10. After 15 min transfer liquid to Eppendorf tubes, add 0.1 ml phase separation solution, vortex for 1 min, spin at $20,000 \times g$ for 20 min.
11. Collect aqueous phase, add equal amount of isopropanol, incubate at -20°C for 1 h, spin at $20,000 \times g$ for 25 min, and rinse pellet once with 75% ethanol followed by centrifugation at $13,500 \times g$ for 10 min.
12. Add 0.035 ml DEPC-treated water to dissolve RNA pellet.
13. Take 1 μl of RNA, set up one-step RT-PCR reaction using SuperScript One-Step RT-PCR with Platinum Taq.

14. Mix 1 μl of template ($\sim 10 \text{ pg} - 1 \text{ }\mu\text{g}$), 12.5 μl of 2 \times reaction mix, 0.5 μl of each of the 1st PCR primers diluted to a 10 μM stock solution, 0.5 μl of RT/Platinum Tag Mix, H_2O to a final volume of 25 μl . Mix the reaction by vortexing and centrifuge briefly. Run the reaction on a PCR machine with conditions optimized for your specific primers.
15. Set up nested PCR reaction using Illustra™ puReTaq Ready-To-Go PCR Beads.
16. Mix 0.2 μl of the 1st amplicon, 1 PCR bead, 0.5 μl of each of the nested PCR primers diluted to a 10 μM stock solution, H_2O to a final volume of 25 μl .
17. Mix the reaction by vortexing and centrifuge briefly. Run the reaction on a PCR machine using conditions optimized for your primer pair.
18. Run 5.0 μl of nested PCR amplicon on 1%(wt/vol) agarose gel in TAE buffer. Take photo using gel imaging system after running the gel at 130 V for 30 min (*see Note 4*).

3.6 Vector Quality Control

3.6.1 Genetic Integrity

1. Carefully check the nucleotide map of your insert and the Ad genome within the viral molecular clone.
2. Select two enzymes that cut the combined sequence at 3–6 different sites.
3. Calculate the size of each band that you expect upon digestion.
4. Isolate DNA from $\sim 1 \times 10^{12}$ vp of vectors with Qiagen kit (DNeasy Blood & Tissue).
5. Place two aliquots of ~ 500 ng of vector DNA into Eppendorf tube.
6. Digest DNA in each aliquot with one of the two different enzymes that you selected.
7. Use the same enzymes to cut the plasmid DNA of the recombinant viral molecular clone.
8. Upon complete digestion, separate bands on 1 % agarose gel, include molecular weight marker, visualize bands on a UV, and take photo of gel.
9. Carefully check: if only bands of the expected size are present, the same bands should be present in the digest of the viral molecular clone (*see Note 5*).

3.6.2 Expression of the Transgene Product

1. Infect 70–80 % confluent HEK 293 cells plated the day before into a six-well plate at 2×10^6 cells/well with 10^8 , 10^9 , and 10^{10} vp of vector, infect an additional well with 10^{10} vp of a control vector.
2. Harvest cells 48 h later. If transgene product is secreted, harvest supernatant as well.

3. The procedure for detection of transgene product will vary depending on the type of the protein and on availability of antibodies for detection.
4. Proteins for which antibodies are available use Western blots, immunoprecipitation, or immunofluorescent stains, followed by analysis by flow cytometry.
5. If antibodies are not available assess levels of transgene product-specific transcripts by a real-time PCR of reverse-transcribed cDNA [*see* **Note 6**].

3.6.3 LPS Content

1. Test purified vectors with the Cape Cod Endotoxin kit following the manufacturer's instructions.
2. Endotoxin levels should be <0.5 EU per 10^{12} vp; batches with higher levels should not be used in animals.

3.6.4 Content of Replication Competent Ad

1. Plate A549 cells into six-well plates, set up three plates; next day check cells to ensure that they are semiconfluent.
2. The same day dilute vector to 2×10^9 , 2×10^{10} , and 2×10^{11} vp/ml in A549 cell growth medium, and dilute wild-type adenovirus to 2, 20, or 200 IU/ml.
3. In separate tubes mix 1 ml of the three dilutions of wild-type virus with 1 ml of the 2×10^{11} vp dilution of vectors.
4. Remove medium from A549 cells, add 0.5 ml of the vector or wild-type virus dilutions and 1 ml of the vector-wild-type virus mixtures to the A549 cells, adjust final volumes to 1 ml.
5. Incubate for 2 h at 37 °C.
6. Prepare ~20 ml of 2 % Seahorse agarose solution in H₂O.
7. Once cells are infected for ~2 h, boil Seahorse agarose solution in microwave, pipette agarose up and down till solution is homogenous, mix 20 ml of the agarose with 20 ml of 2× medium, and remove supernatant from A549 cells.
8. Make sure that temperature of agarose-medium mixture is acceptable (touch it, if its hot, cool the solution down by pipetting it up and down).
9. Slowly add 2 ml of the agarose solution to each well of the A549 cells.
10. Leave at room temperature till gel solidifies, then incubate for 4–8 days at 37 °C in a 5 % CO₂ incubator.
11. On days 4 and 8 check for viral plaques under a microscope; viral plaques should form in wells incubated with wild-type virus, and plaque formation by wild-type virus should not be affected by addition of replication-defective vectors; replication-defective vectors should not result in viral plaques.

3.6.5 Genetic Stability

1. Plate 2×10^6 HEK 293 cells in one well of a six-well plate, and continue to do this every second day
2. The next day check if cells are ~90 % confluent.
3. Then add 2×10^6 vp of vector from the MVB to the cells, incubate for 2 days, by then most of the cell monolayer should be destroyed.
4. Collect the cells, spin down, dilute cell pellet in 1 ml of medium and freeze-thaw as described above.
5. Pellet cell debris by centrifugation and add half of the supernatant to HEK 293 cells in a six-well plate (prepared the day before).
6. Repeat this process 11 more times.
7. After the 12th passage, expand virus into a T25 flask, from there into 2 T175 flasks and then into 20 T175 flasks.
8. Harvest and purify vector and then vector genome as described above.
9. Digest purified DNA from the MVB and the serially passaged vector with two sets of restriction enzymes.
10. Run digest on a 1 % agarose gel with ethidium bromides and molecular weight markers.
11. The banding pattern of the genomes of vector from the MVB and the late passage should be identical (*see Note 7*).

4 Notes

1. Problems with assembling a recombinant molecular clone may occur. An abundance of bacterial colonies upon transformation with the control ligation mixtures (molecular clone without insert) indicates incomplete digestion of the molecular clone; increase amount of I-CeuI and PI-SceI restriction enzymes or time used for digestion. Check digestion by gel electrophoresis. Colonies with plasmids that are smaller than the expected recombinant viral clone may reflect DNA breakage. Try again but avoid vigorous shaking or pipetting of the viral molecular clone. Lack of insert especially upon blunt end ligation is common and can be addressed by changing the ratio of insert to molecular clone DNA.
2. Virus fails to rescue or the initial viral plaques fail to expand. This could reflect that the HEK 293 cell passage number is too high. Using freshly thawed cells with a lower passaging number can easily address this. The DNA of the recombinant clone may be contaminated with a substance that interferes with transfection or the transfection may have been inefficient. Using a control viral molecular clone that carries an expression

cassette for green fluorescent protein (GFP) can check for this as it allows for direct visualization of transfected cells under a fluorescent microscope. Checking the cells daily also gives insight into the speed of viral propagation as clusters of infected cells become visible around day 3–5; they should slowly grow bigger and then eventually form viral plaques. Good transfection efficacy with lack of plaque formation may indicate that the HEK 293 cells can no longer support virus growth. Some vectors simply cannot be rescued—the protein is too toxic or something within the vector genome allows for homologous recombination resulting in loss of genes that are essential for viral growth. In this case, occasionally small viral plaques are observed that eventually disappear. In general, try to rescue a viral molecular clone three times and if failure continues, reconstruct the expression cassette within pShuttle. If it is known that a protein is toxic, remove the intron or enhancer, or change the promoter.

3. There is no band upon CsCl gradient separation. This reflects poor expansion of the virus, which could either relate to the passage number of HEK 293 cells, a suboptimal protocol for vector expansion or genetic instability of the vector. The latter poses the most challenging problem, as it again requires reconstruction of the recombinant pShuttle vector. There is no boilerplate protocol on how to optimize the process for expansion of a new Ad vector, which has not yet been titrated. Some Ad vectors grow fast, others more slowly. Check infected cells carefully for CPE each day after infection and depending on the degree of CPE, vary the time from infection to harvest.
4. Vector yields, measured by vp content, are low. This again can reflect genetic instability or toxic transgenes (*see Note 5*) or more likely a suboptimal protocol for vector expansion (*see below*). The vp to IU ratio may be unacceptably high (>1000:1). If the vector passes the other quality control studies, this again most likely reflects a suboptimal protocol for vector expansion, which in most cases is fixed by conducting a second expansion using 0.5–1 IU/cell for infection of HEK 293 cells.
5. Upon restriction enzyme digest of the viral DNA the banding pattern is different from the expected banding pattern. This can be caused by partial digestion, initially; repeat the digestion using more enzymes or a longer incubation time. It could also reflect that part of the genome was lost during viral rescue. Most commonly the entire or part of the transgene expression cassette is deleted; however, deletions in nonessential regions of the Ad genome have been observed. This can be caused by undue stress during viral rescue and expansion linked to high passage HEK 293 cells or other adverse conditions such as problems with the incubator (wrong temperature, wrong CO₂

concentration) or the growth medium (fetal calf serum batch) or in a worst case scenario inherent vector genome instability. As a rule, re-rescue, expand, and purify the vector again; if the problem persists, reconstruct the expression cassette.

6. Lack of protein expression by vectors that upon restriction enzyme digest of their genome yield the expected banding pattern may reflect point mutations within the expression cassette that arose during viral rescue or expansion. To assess the former, test cells transfected with the pShuttle-transgene vectors for 2–3 days for expression of the protein. If pShuttle-transgene fails to express the protein, reconstruct the expression cassette. If the protein is expressed by pShuttle but not by the Ad vector, sequence the expression cassette within the vector genome. Point mutations within crucial regulatory elements or the transgene indicate genetic instability, so backtrack and reconstruct the pShuttle-transgene vector.
7. Outgrowth of replication competent virus is caused by homologous recombination between the E1 within HEK 293 cells and the E1-flanking regions within the viral molecular clone. It is a serendipitous event that is hard to control for. It can be avoided by using for example simian Ads, which do not recombine with the E1 of HAdV-5 or by using alternative cell line such as PerC6 cells which are not readily available to academia. Alternatively one can develop vectors with additional deletions such as of E4 but this requires construction of new packaging cell lines. As a rule, if high levels of RCAs are observed, repeat viral rescue and expansion.
8. We only conduct this assay for vectors that we plan to eventually advance to clinical testing. If the restriction enzyme-digest banding pattern changes upon serial passages, the vector is genetically unstable. This happens rarely at this late stage as genetic instability in general shows up after the first large-scale expansion. Nevertheless, it has happened to us and we ended up reconstructing the transgene expression cassette.

References

1. Xiang ZQ, Yang Y, Wilson JM, Ertl HC (1996) A replication-defective human adenovirus recombinant serves as a highly efficacious vaccine carrier. *Virology* 219:220–227
2. Xiang ZQ, Greenberg L, Ertl HC (2014) Rupprecht CE (2014) Protection of non-human primates against rabies with an adenovirus recombinant vaccine. *Virology* 450–451:243–249
3. Colloca S, Barnes E, Folgori A et al (2012) Vaccine vectors derived from a large collection of simian adenoviruses induce potent cellular immunity across multiple species. *Sci Transl Med* 4:115ra2
4. Ledgerwood JE, Costner P, Desai N, VRC 205 Study Team (2010) A replication defective recombinant Ad5 vaccine expressing Ebola virus GP is safe and immunogenic in healthy adults. *Vaccine* 29:304–313
5. Hung PP, Morin JE, Lubeck MD et al (1988) Expression of HBV surface antigen or HIV envelope protein using recombinant adenovirus vectors. *Nat Immun Cell Growth Regul* 7:135–143
6. Khanam S, Pilankatta R, Khanna N, Swaminathan S (2009) An adenovirus type 5 (AdV5) vector encoding an envelope domain III-based tetravalent antigen elicits immune

responses against all four dengue viruses in the presence of prior AdV5 immunity. *Vaccine* 27:6011–6021

7. Shim BS, Stadler K, Nguyen HH et al (2012) Sublingual immunization with recombinant adenovirus encoding SARS-CoV spike protein induces systemic and mucosal immunity without redirection of the virus to the brain. *Virology* 9:215
8. Sharma A, Wendland R, Sung B et al (2014) Maternal immunization with chimpanzee adenovirus expressing RSV fusion protein protects against neonatal RSV pulmonary infection. *Vaccine* 32:5761–5768
9. Li K, Li PY, Wu XA et al (2013) Induction of Hantaan virus-specific immune responses in C57BL/6 mice by immunization with a modified recombinant adenovirus containing the chimeric gene, GcS0.7. *Int J Mol Med* 32:709–716
10. Wang Y, Liu C, Xia Q et al (2014) Antitumor effect of adenoviral vector prime protein boost immunity targeting the MUC1 VNTRs. *Oncol Rep* 31:1437–1444
11. Aurisicchio L, Peruzzi D, Koo G et al (2014) Immunogenicity and therapeutic efficacy of a dual-component genetic cancer vaccine cotargeting carcinoembryonic antigen and HER2/neu in preclinical models. *Hum Gene Ther* 25:121–131
12. Pedersen SR, Sørensen MR, Buus S et al (2013) Comparison of vaccine-induced effector CD8 T cell responses directed against self- and non-self-tumor antigens: implications for cancer immunotherapy. *J Immunol* 191:3955–3967
13. Lubaroff DM, Konety BR, Link B et al (2009) Phase I clinical trial of an adenovirus/prostate-specific antigen vaccine for prostate cancer: safety and immunologic results. *Clin Cancer Res* 15:7375–7380
14. Shiver JW, Fu TM, Chen L et al (2002) Replication-incompetent adenoviral vaccine vector elicits effective anti-immunodeficiency-virus immunity. *Nature* 415:331–335
15. Tatsis N, Fitzgerald JC, Reyes-Sandoval A et al (2007) Adenoviral vectors persist in vivo and maintain activated CD8+ T cells: implications for their use as vaccines. *Blood* 110:1916–1923
16. Zhou D, Zhou X, Bian A et al (2010) An efficient method of directly cloning chimpanzee adenovirus as a vaccine vector. *Nat Protoc* 5:1775–1785

Generation of Lymphocytic Choriomeningitis Virus Based Vaccine Vectors

Sandra Ring and Lukas Flatz

1 Introduction

Exposure of mice to the prototypic arenavirus lymphocytic choriomeningitis virus (LCMV) is one of the best infection models to study T cell immunity. Important key concepts in immunology and viral pathogenesis such as MHC restriction, T cell exhaustion, and persistent viral infections were developed studying LCMV [1, 2]. In 1933, LCMV was first isolated by Armstrong and Lillie from a patient who was suspected to suffer from an infection with the St. Louis Encephalitis Virus [3]. Persistently LCMV infected rodents spread the virus with the urine, feces or saliva. LCMV can also be transmitted to humans through contact with infected murine excretions. In immunocompetent individuals an infection with LCMV often remains asymptomatic or shows mild flu-like symptoms. However, immunosuppressed individuals particularly organ-recipients can develop life threatening severe aseptic meningitis or meningoencephalitis [4]. Furthermore, LCMV is a particular concern for pregnant women as it was shown that congenital infection can lead to severe and permanent brain injury in children [5, 6].

LCMV is a non-cytopathic enveloped negative-strand RNA virus with a spherical shape and a diameter between 50 and 300 nm. Its genome consists of two single-strand RNA segments both encoding for two viral genes in ambisense orientation. The viral genes on each segment are separated by an intergenic region (IGR) which forms a stable hair pin loop in the RNA sequence (Fig. 1a). The short segment (S segment) is 3.4 kb long and contains the glycoprotein (GP) precursor (GPC) genes, GP-1 and GP-2, and the nucleoprotein (NP) gene [7]. The nucleoproteins build complexes with the viral RNA segments. The glycoprotein of LCMV forms the spikes on the viral envelope and mediates the interaction with host cell surface receptors and the entry of the virus into the

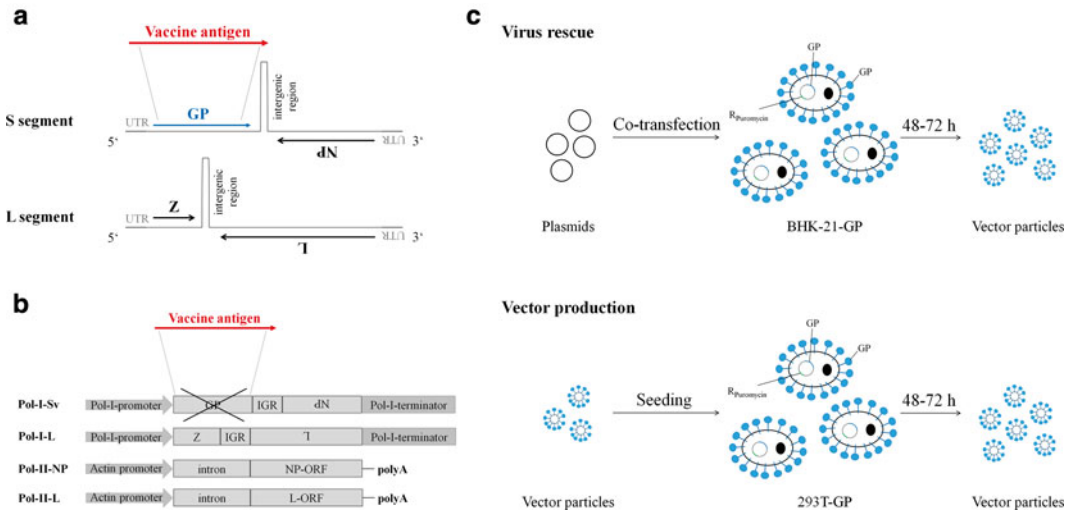

Fig. 1 Schematic overview of the generation of recombinant LCMV vectors. **(a)** The wild-type LCMV genome is composed of two single-strand RNA segments (S and L segment). The S segment encodes for the GP and NP and the L segment encodes for Z and L. In the rLCMV vectors the gene encoding the LCMV-GP is substituted with a gene of interest (vaccine antigen). **(b)** The RNA genome, composed of the S and L segment, is intracellularly expressed under the control of a rodent-specific Pol-I-promoter and a Pol-I-terminator (Pol-I-Sv and Pol-I-L). The plasmids Pol-II-NP and Pol-II-L contain the ORFs for the *trans*-acting proteins NP and L with a poly-A tail under the control of an actin promoter. **(c)** rLCMV vectors are created with a four-plasmid transfection system in BHK-21-GP producer cells (virus rescue). For the generation of viral vectors, 293T-GP cells are used (virus production). Both cell lines stably express the viral GP to complement the GP-deficient genomes *in trans*

host cell. Therefore, the LCMV-GP represents the only target for neutralizing antibodies against LCMV. However, it was shown that convalescent serum fails to prevent reinfection with LCMV, hence proving that the neutralizing antibody response to LCMV is extremely weak [8]. The long segment (L segment) is 7.2 kb long and encodes for the RNA-dependent RNA polymerase (L) and a small Zn²⁺ ion-binding RING finger protein (Z). Lee and colleagues [9] demonstrated that both GP and Z are required for the assembly and budding of LCMV-infectious virus-like particles (VLPs).

Reverse genetics of arenaviruses and LCMV in particular have been hampered for a long time due to the fact that it is a negative-strand RNA virus with an ambisense coding strategy, i.e., transfection of permissive cells with purified viral RNA does not initiate an infectious cycle. Recent efforts combining recombinant cDNA technology and bioengineering have made it possible to manipulate the LCMV genome [10–13]. Due to these technologies LCMV vectors can be modified to create propagation-incompetent vaccine vectors with an acceptable safety profile and to incorporate diverse vaccine antigens into their genome. In the described recombinant LCMV (rLCMV) vaccine vectors the LCMV-GP is substituted with a gene of interest (vaccine antigen, Fig. 1a). As LCMV-GP is important

for viral cell entry and thus viral propagation, this substitution renders the virus propagation-incompetent *in vivo* and *in vitro* [14]. For the generation of rLCMV vectors in which GP is replaced by a vaccine antigen a four-plasmid co-transfection system is used which was originally established to generate wild-type LCMV [11]. Pol-I-Sv and Pol-I-L contain the S and the L vector RNA genome segment under the control of a rodent-specific RNA polymerase I promoter and terminator. This enables the transcription of the viral RNA in a producer cell line and the incorporation of the rLCMV RNA genome into the vector particles. In the Pol-I-Sv plasmid the LCMV-GP is substituted with the desired antigen of interest. Additional plasmids, Pol-II-L and Pol-II-NP, ensure the co-expression of the *trans*-acting proteins NP and L under a mammalian-specific RNA polymerase II promoter (Fig. 1b). Due to the missing GP, rLCMV vaccine vectors are propagation-incompetent and cannot enter new host cells. Therefore, producer cell lines are generated, BHK-21-GP or 293T-GP cells that are stably transfected with an LCMV-GP expression vector [15]. Thereby, the GP-deficient viral genomes are complemented *in trans* and generate viral vectors whose RNA can be amplified and expressed in target cells (Fig. 1c). We have previously demonstrated that the generated rLCMV vectors could not give rise to spreading virus and propagate infection *in vitro* and *in vivo* [14].

Thus, a protocol has been established to efficiently manipulate the LCMV genome for the generation of safe propagation-incompetent rLCMV vectors expressing antigens of interest. Furthermore due to the natural tropism of LCMV for dendritic cells and the induction of a broad and long-lived cytotoxic T lymphocyte (CTL) response [16], LCMV represents a persuasive vaccine vector for the induction of a potent CTL response against infectious diseases and cancer.

2 Materials

2.1 Components for Cloning

1. Kits and enzymes: Direct-Zol RNA Miniprep Kit (Zymo Research, USA), High Capacity cDNA Reverse Transcription Kit (Applied Biosystems), NucleoSpin Gel and PCR Clean-up Kit and NucleoSpin Plasmid (Machery Nagel), High Fidelity Polymerase (e.g., HotStar High Fidelity Polymerase Kit, Qiagen), T4 DNA Ligase (Promega).
2. Restriction enzymes: BsmBI, and other restriction enzymes according to the cloning strategy (NEB).
3. Culturing of competent bacteria (e.g., DH5 α competent cells) in LB medium, pH 7.5 (1 l): 10 g Bacto tryptone, 5 g yeast extract, 10 g NaCl. Selection of positive clones after transformation: 100 μ g/ml ampicillin.
4. Components for agarose gel electrophoresis.

2.2 Components for Cell Culture and Transfection

1. Cell culture: DMEM+ GlutaMAX™-I with 5–10 % FCS and 1 % penicillin/streptomycin (100×), trypsin–EDTA in 1× PBS, Opti-MEM® I (all from Life Technologies). Selection of stably transfected cells: 2 µg/ml puromycin.
2. Lipofectamine 2000 (Invitrogen).
3. T-75, and T-150 flasks, 6-well, 24-well, and round-bottom 96-well plates (TPP), 5 ml Polystyrene round-bottom tubes (Falcon, BD).

2.3 Components for the Immunofocus Assay

1. Overlay medium: Mix 2× DMEM and 2 % Methylcellulose 1:1 directly before use. 2× DMEM: Dissolve 27 g of DMEM-powder (Sigma-Aldrich) and 7.4 g of NaHCO₃ in 1 l H₂O. Adjust the pH to 7.4 and filter the medium. Shortly before use add 10 % FCS and 2× Penicillin/Streptomycin.
2 % Methylcellulose: Dissolve 10 g of methylcellulose (Methocel, Sigma-Aldrich) in 500 ml H₂O and stir overnight at 4 °C. Autoclave to sterilize and stir again at 4 °C for several days to ensure the total dissolving of the methylcellulose. Check from time to time.
2. Prepare a 4 % Paraformaldehyde (PFA) solution: For Solution A prepare a 0.2 M Na Phosphate (pH 7.4) solution. Therefore, mix 77.4 ml 1 M Na₂HPO₄ with 22.6 ml 1 M NaH₂PO₄, adjust the pH to 7.4 and fill up with H₂O to 500 ml. For solution B prepare 8 % PFA in H₂O. Dissolve 40 g PFA in H₂O and warm the solution to approximately 50 °C on a magnetic stirrer. Then slowly add 5 N NaOH until the solution clears up and adjust the pH to 7.4. Solution A can be stored at room temperature and solution B at –20 °C. To obtain a 4 % buffered PFA solution, mix solutions A and B 1:1. As an alternative you can use the ready-to-use 4 % buffered Formafix (Formafix, Switzerland).
3. 1 % Triton X-100 in 1× PBS.
4. 10 % FCS and 1 % FCS in 1× PBS.
5. Antibodies: rat-α-LCMV, clone VL-4 (BioXCell, Order# BE0106), 1:200 in DMEM, and peroxidase-conjugated goat-α-rat IgG (H+L; Jackson, Order# 112-036-062), 1:400 in PBS with 1 % FCS.
6. SIGMAFAST™ OPD (*o*-phenylenediamine dihydrochloride) Tablets (Sigma-Aldrich, Order# P9187). Dissolve one urea/hydrogen peroxide/buffer tablet and one OPD tablet in 10 ml H₂O.

2.4 Components for the Analysis of the Induced CTL Response In Vivo

1. C57BL/6 mice, 8–12 weeks.
2. Buffer for FACS analysis: 2 % FCS, 2 mM EDTA, and 0.1 % NaN₃ in 1× PBS.

3. Erythrocyte lysis of blood samples: BD FACS™ Lysing Solution (BD Bioscience), prepare a 1:10 dilution in H₂O.
4. Tetramer and antibodies for FACS analysis: OVA₂₅₇₋₂₆₄ (SIINFEKL)-PE (TCMetrix, Epalinges, Switzerland), α -CD8a-APC (clone 53-6.7, Biolegend).
5. 100 μ m cell strainer and 70 μ m Cup Filcons (BD Biosciences).

3 Methods

3.1 Cloning of the Gene of Interest (Vaccine Antigen) into the Pol-I-Sv Plasmid

Generate the plasmids Pol-I-Sv, Pol-I-L, Pol-II-L, and Pol-II-NP (Fig. 1b) as described [10, 11]. The exact cloning of the gene sequences is very important, especially for the Pol-I-Sv and the Pol-I-L plasmid, because the RNA of these plasmids will be incorporated later into the vector particles. The cloning of the antigen of interest into the Pol-I-Sv plasmid is performed as described [14]. The GP is deleted from the start codon to the stop codon and the gene of interest is inserted exactly between the 5'UTR and the IGR. Additionally the Pol-I-Sv plasmid encodes for the Ampicillin resistance gene and positive bacteria clones can be selected with Ampicillin. All kits are used according to manufacturer's instructions.

1. Isolate RNA from target cells and transcribe the isolated RNA to cDNA. Amplify the desired gene sequence by PCR using primers with associated restriction sites for BsmBI (5'...CGTCTC(N)₁▼...3' and 3'...GCAGAG(N)₅▼...5', *see* **Notes 1** and **2**). To verify the amplification of the gene sequence, run the PCR reaction on an agarose gel and purify the PCR product afterwards from the agarose gel.
2. Digest the purified PCR product and the Pol-I-Sv plasmid with BsmBI at 55 °C for 1 h (*see* **Note 3**). Again purify the digested PCR product and the Pol-I-Sv plasmid from an agarose gel.
3. Perform a ligation of the digested PCR product into the Pol-I-Sv plasmid using the T4 DNA ligase.
4. Use competent bacteria to amplify the Pol-I-Sv plasmid with the inserted target antigen. Plate the transformed bacteria on LB plates containing 100 μ g/ml Ampicillin and incubate the plates overnight at 37 °C.

On the next day pick positive clones from the plate and inoculate them in 3 ml LB containing 100 μ g/ml ampicillin. Grow the cultures on a shaker overnight at 37 °C and 200–250 \times g. The following day re-isolate the Pol-I-Sv plasmid and perform a restriction digest to check if the desired gene sequence is inserted into the plasmid (*see* **Note 4**). To additionally verify the correct insertion of the gene sequence of interest into the Pol-I-Sv plasmid, sequence the plasmid.

3.2 Four-Plasmid Co-transfection and Virus Rescue

Generate the BHK-21-GP cells (*see Note 5*) as described [15] and grow them in DMEM with 10 % FCS. BHK-21-GP cells are stably transfected with the plasmid M369 that expresses a codon-optimized LCMV-GP cDNA and the resistance gene for puromycin. Therefore, stable transfectants are maintained with the addition of 2 µg/ml puromycin to the culture medium. Incubate the cells at 37 °C and 5 % CO₂ in an incubator.

1. Grow the BHK-21-GP cells in 150 cm² flasks. One day before transfection seed 6×10^5 cells/well in 2 ml medium in a 6-well plate. On the day of transfection cells should be around 80 % confluent.
2. On the day of transfection prepare the Plasmid-Lipofectamine mix in 5 ml Polystyrene Snapcap tubes as follows: in the first tube mix 100 µl Opti-MEM with 12 µl Lipofectamine (Lipofectamine mix). In a second tube add 0.8 µg Pol-I-Sv, 1.4 µg Pol-I-L, 0.8 µg Pol-II-pC NP, and 1.0 µg Pol-II-pC L to 100 µl Opti-MEM. As a negative control leave one plasmid of choice out of the mix. Add drop by drop 12 µl of the Lipofectamine mix from the first tube to the second tube with the plasmid mix and incubate for 30–40 min at room temperature.
3. After the incubation time add 800 µl Opti-MEM to the mix and immediately proceed with **step 4**.
4. Carefully remove the supernatant of the BHK-21-GP cells, add 1 ml Plasmid/Lipofectamine mix to the cells and incubate the cells for 5 h at 37 °C.
5. Remove the Plasmid/Lipofectamine mix and replace it with 2 ml of pre-warmed cell culture medium. Incubate the cells for 72 h at 37 °C.
6. After 72 h remove the supernatant and discard it. Wash the cells once with 1× PBS. Add 500 µl Trypsin per well and incubate at 37 °C until the cells detach. Resuspend the cells in 20 ml fresh pre-warmed cell culture medium, seed them in a 75 cm² flask and incubate them for 48 h at 37 °C.
7. After 48 h remove the supernatant and store the aliquots at –80 °C. To quantify the rLCMV vector titer perform an immunofocus assay on 293T-GP cells with an aliquot which has been frozen.

3.3 Generation of rLCMV Stocks

Generate 293T-GP cells as described [15] and grow them in DMEM with 10 % FCS. 293T-GP cells are stably transfected with the plasmid M369 that expresses a codon-optimized LCMV-GP cDNA and the resistance gene for puromycin. Therefore, stable transfectants are maintained with the addition of 2 µg/ml puromycin to the culture medium. Incubate the cells at 37 °C and 5 % CO₂ in an incubator.

1. Grow 293T-GP cells in 150 cm² flasks. One day before infection seed cells at approximately 5×10^6 cells per 150 cm² flask and incubate them overnight in an incubator. At the day of infection cells should be 80–90 % confluent.
2. On the day of infection remove the supernatant and add the virus at a multiplicity of infection (MOI) of 0.1–0.01 (*see Note 6*) in 2 ml DMEM with 5 % FCS (without puromycin). Incubate at room temperature for 20 min and carefully rotate the flask from time to time (*see Note 7*) so that the virus is distributed evenly and is adsorbed.
3. Add 15 ml 5 % DMEM and incubate the cells for 48 h at 37 °C.
4. After 48–72 h (*see Note 6*) transfer the supernatant into 50 ml Falcons and centrifuge for 10 min at $400 \times g$ to remove remaining cells.
5. Make aliquots of the supernatant and store them at –80 °C. Perform an immunofocus assay on 293T-GP cells to determine the rLCMV vector titer with an aliquot which has been frozen (*see Note 8*).

3.4 Immunofocus Assay for the Determination of rLCMV Vector Titers

Determine rLCMV vector titers by performing an immunofocus assay based on the original protocol by Battegay et al. [17]. However, as the viral vector particles are propagation-incompetent due to the removal of the GP, 293T-GP cells (*see Note 9*) are used instead of MC57 cells as described in the original protocol for the immunofocus assay.

3.4.1 Titration of rLCMV

Carry out all steps on ice unless otherwise specified to keep the virus viable. For the following steps use an 8-channel multichannel pipette. As a positive control use a virus sample with a known titer and as a negative control use only cells without a virus sample.

1. Grow 293T-GP cells in 150 cm² flasks in DMEM with 10 % FCS and 2 µg/ml puromycin until they reach 80–90 % confluency. Detach the 293T-GP cells with the culture medium from the bottom of the cell culture flasks and transfer them into 50 ml Falcon tubes. After centrifugation at $300 \times g$ for 1 min/2 ml volume discard the supernatant and resuspend the cells in DMEM with 5 % FCS (without puromycin). Determine the cell number and use 2.4×10^5 cells/well in 200 µl/well for the titration (*see Note 10*). Keep the cells on ice while diluting the virus samples.
2. For each virus sample four rows of a 96-well round-bottom plate are used. Prepare a dilution of the rLCMV vector sample in DMEM with 5 % FCS (*see Subheading 3.4.2, step 13*, dilution factor, e.g., 1:5 dilution). Add 200 µl of the rLCMV vector sample in the first column (Fig. 2a, sample).

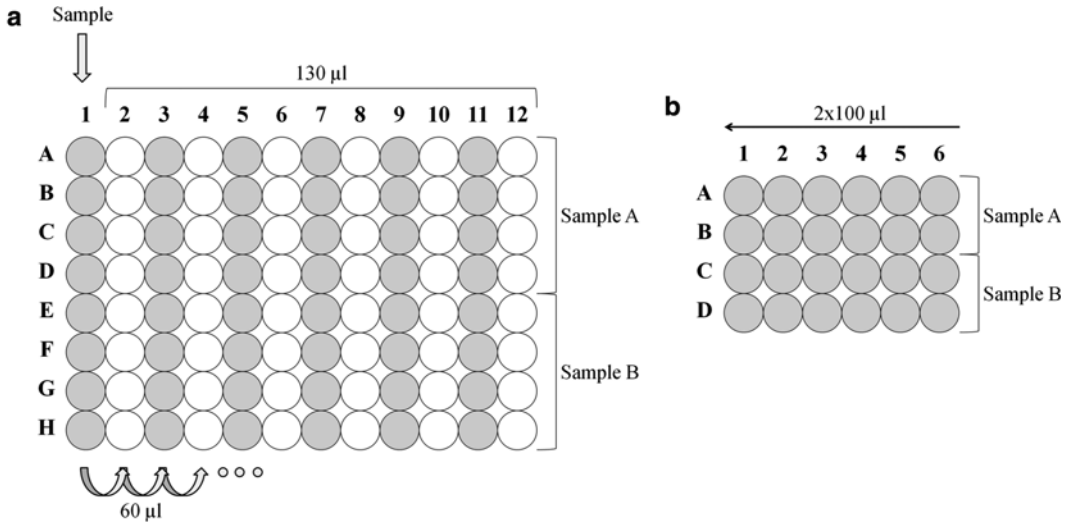

Fig. 2 Pipetting scheme for the determination of rLCMV vector titers (Immunofocus Assay). Viral vector titers are determined on 293T-GP cells. (a) Pipetting scheme for a 96-well plate. Virus samples are added to the first column. Grey circles represent columns when pipette tips are changed and which samples are transferred to a (b) 6-well plate. The arrow represents the working direction from the right to the left side of the plate

3. Add 130 µl of DMEM per well into column 2–11 (Fig. 2a).
4. Gently mix the samples in the first row and transfer 60 µl from column 1 to column 2 using a multichannel pipette. Mix the samples in column 2 and transfer 60 µl from column 2 to column 3. Do not mix in column 3 and change pipette tips.
5. Repeat **step 4** for the following columns until you reach column 12. Thereby change pipette tips after transferring 60 µl into columns 3, 5, 7, 9, and 11 (Fig. 2a, grey circles).
6. Transfer 200 µl (2×100 µl, two pipette tips per well) from column 11 of the 96-well plate to column 6 on a 24-well plate (Fig. 2b).
7. Repeat **step 6** and transfer 200 µl (2×100 µl) from columns 9, 7, 5, 3, and 1 of the 96-well plate (Fig. 2a, grey circles) to columns 5, 4, 3, 2, and 1 on the 24-well plate (Fig. 2b). To avoid contamination start in column 11 and 6, respectively, and work from the right to the left side of the plates (Fig. 2b, black arrow). Add 200 µl (2×100 µl) 293T-GP cells (prepared in **step 1**) to each well of the 24-well plate starting again in column 6. To avoid contamination again work from the right to the left side of the plate and change pipette tips regularly.
8. Softly tap the plates to ensure a homogenous distribution of the cells and to mix cells with the virus (*see* **NOTE 10**). Incubate the plates for 2–4 h at 37 °C in an incubator.
9. To prevent spreading of the virus on all cells in a well very gently add 200 µl (2×100 µl) overlay medium (use cut tips) to each well. Slowly rinse down the overlay medium along the

wall of the wells to avoid damage of the cellular monolayer. Incubate the plates in an incubator for 48 h until a uniform monolayer has formed.

3.4.2 Staining of Viral Foci

Carry out all procedures at room temperature. Prepare a container with 1× PBS to wash the plate.

1. After 48 h of incubation gently flick off the overlay (*see Note 11*). Fix the monolayer with 200 µl (2 × 100 µl) of 4 % PFA and incubate the plates for 30 min (*see Note 12*).
2. Gently flick off the liquid (*see Note 13*) and wash the plate twice in the container with 1× PBS. Dry the plate on a paper towel.
3. Add 4–5 drops of 1× PBS with 1 % Triton X-100 (permeabilization solution) to each well and incubate for 20 min.
4. Wash as in **step 2**.
5. Add 4–5 drops of 1× PBS with 10 % FCS (blocking solution) to each well and incubate for 30 min.
6. Gently flick off the liquid and dry the plate on a paper towel.
7. Dilute the first antibody (rat-α-LCMV, clone VL-4, *see Note 14*) in DMEM with 5 % FCS. Add 200 µl (2 × 100 µl) of the first antibody to each well and incubate for 60 min.
8. Wash as in **step 2**.
9. Prepare the second antibody in 1× PBS with 1 % FCS (Peroxidase-conjugated goat-α-rat IgG, 1:400). Add 200 µl (2 × 100 µl) of the second antibody to each well and incubate for 60 min.
10. Wash as in **step 2**.
11. Prepare the OPD substrate by dissolving one tablet set in 10 ml deionized water. Add 200 µl (2 × 100 µl) of the OPD solution to each well and incubate until the foci develop. Wait until brown foci become clearly visible on the cell monolayer.
12. Gently flick off the liquid and stop the reaction by washing the plates in a container with tap water. Dry the inverted plate on Whatman paper.
13. Determine the number of foci for all the wells where you can easily count separate foci. Calculate the titer of the viral vector (immunofocus forming units per ml) with the following formula (*see Notes 15 and 16*).

$$\frac{\text{foci number} \times \text{dilution factor}}{0.2\text{ml}} = \text{IFU} / \text{ml}$$

3.5 Analysis of the Induced CTLA Response against the Vaccine Antigen In Vivo

To show an example for the induction of a CD8⁺ T cells response against an antigen of interest C57BL/6 mice are immunized intraperitoneally (ip) with 1 × 10⁵ IFU/ml rLCMV vectors expressing the ovalbumin (OVA) antigen (*see Note 17*). Mice are then analyzed on day 10 (*see Note 18*) after immunization (Fig. 3).

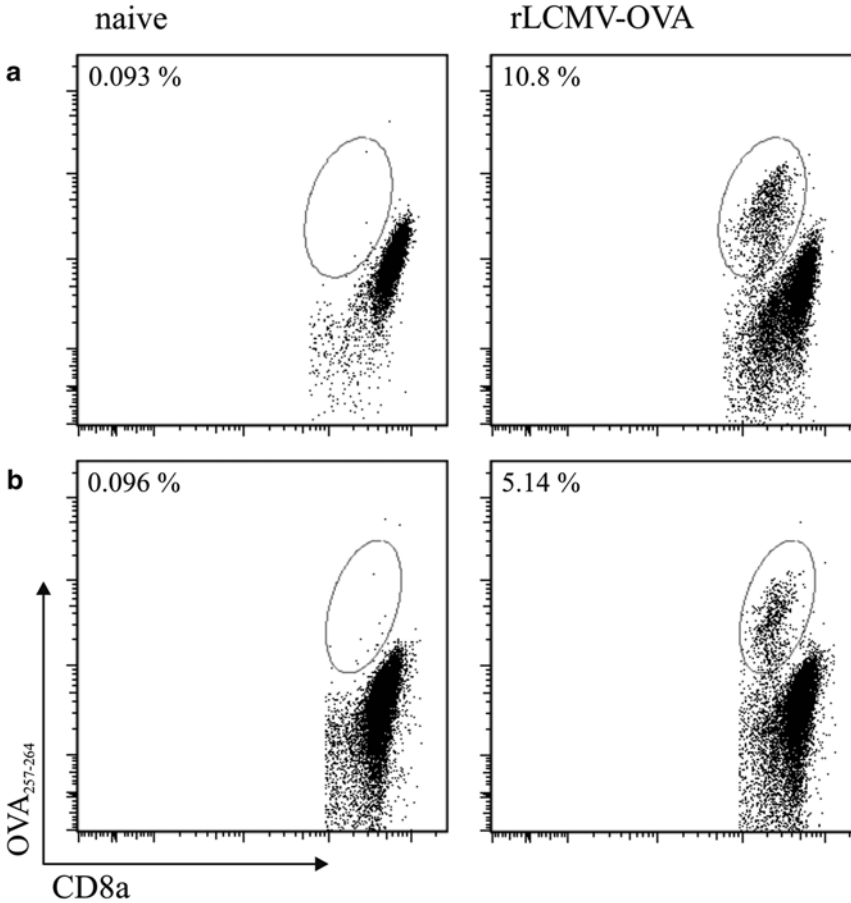

Fig. 3 Immunization of mice with rLCMV-OVA elicits an OVA-specific CD8⁺ T cell response. C57BL/6 mice were immunized with 1×10^5 IFU rLCMV-OVA ip. (a, b) SIINFEKL-specific CD8⁺ T cell response was measured in the (a) blood and (b) spleen on day 10 after immunization

3.5.1 Tetramer Staining of CD8⁺ T Cells in Blood

Keep the blood samples on ice and carry out all the procedures on ice unless specified otherwise. Carry out all centrifugation steps at 4 °C for 5 min at $300 \times g$.

1. Prepare 5 ml Falcon tubes containing 3 ml of FACS buffer.
2. In order to dilate the blood vessel prior to taking the blood sample warm the mice under a red lamp (*see Note 19*) or put the tail in warm water (40 °C). Make the mice comfortable in a restrainer. Use a needle to prick the tail vein and collect 3–4 drops of blood in a tube containing FACS buffer.
3. Centrifuge your samples and discard the supernatant carefully. Perform the tetramer staining under appropriate conditions for each TCR/Tetramer. For the OVA₂₅₇₋₂₆₄ (SIINFEKL)-PE Tetramer (0.5 μl in 50 μl FACS buffer) incubate the samples at 37 °C for 10 min in the dark (*see Note 20*).

4. Put the samples immediately back on ice and proceed with the surface staining for 20 min in the dark (0.5 μl α -CD8a-APC in 50 μl FACS buffer, final dilution 1:200).
5. Wash the samples once with 3 ml FACS buffer. After centrifugation discard the supernatant carefully and resuspend the cells in 500 μl 1 \times BD Lysis Buffer. Vortex immediately and incubate at room temperature for 5 min in the dark.
6. Wash the samples again with 3 ml FACS buffer and completely discard the supernatant after centrifugation. Resuspend the cells in 100–300 μl FACS buffer and perform FACS analysis (Fig. 3a).

3.5.2 Tetramer Staining of CD8⁺ T Cells in Spleen

Keep the samples on ice and carry out all the procedures on ice unless specified otherwise. Carry out all centrifugation steps at 4 °C for 5 min at 300 $\times g$.

1. Sacrifice the mice and quickly remove the spleens. Keep the spleens in 10 ml FACS buffer on ice until you further process them.
2. Make a single cell suspension of the spleen by mashing it through 100 μm cell strainer with the plunger end of a syringe. Rinse the cell strainer several times with the single cell suspension itself.
3. Centrifuge the samples and discard the supernatant. Resuspend the cells in an appropriate amount of FACS buffer. Transfer 1–5 $\times 10^6$ cells into 5 ml Falcon tubes and add 3 ml FACS buffer. Centrifuge again and discard the supernatant.
4. Perform the tetramer and surface staining as described in Subheading 3.5.1. Wash the cells once with 3 ml FACS buffer and after centrifugation resuspend the samples in 300 μl FACS buffer. Before the FACS analysis filter the samples through 70 μm filters to avoid clogging of your FACS machine (Fig. 3b).

4 Notes

1. The maximum insertion size for an antigen of interest instead of the LCMV-GP gene is around 2000 bp. However, the stability of the S segment may decrease with an increasing size of the insert.
2. As the PCR primers are longer than usual perform a temperature gradient, e.g., ranging from 55 to 65 °C.
3. Check your target gene sequence for internal BsmBI restriction sites. However, you can insert other restriction sites into the Pol-I-Sv plasmid.

4. To check for the insertion of the target sequence into the Pol-I-Sv plasmid use at least two restriction enzymes except BsmBI. It is reasonable to select an enzyme that cuts in the inserted target sequence and an enzyme that cuts in the Pol-I-Sv plasmid backbone.
5. Only the DNA-dependent RNA polymerase of a rodent cell line like BHK-21-GP cells is able to process the inserted Pol-I cassette of the S and L segment. Therefore, viral particles can only be rescued using the BHK-21-GP cell line. Recently other systems were established which use 293T and Vero cells, an FDA-approved cell line for vaccine development, for viral rescue without the need of rodent cell lines [18].
6. For a high yield of the viral titer, test the optimal MOI and generation time for harvesting the viral vectors. A higher MOI for the infection of the 293T-GP cells does not necessarily result in higher viral titers (negative interference). We usually use an MOI of 0.01–0.1 and an incubation time of 48 h.
7. Be careful when you add fresh medium, because 293T-GP cells detach very easily from the bottom of the flask.
8. Avoid freeze-thawing of the viral vectors, because every thawing decreases the viability of the vector particles.
9. It is possible to use BHK-21-GP cells for the immunofocus assay, but in our experience the use of 293T-GP cells results in better and more reliable staining results.
10. It is important that the cells form a monolayer because viral foci are only visible on a uniform monolayer. If cells overgrow it will be difficult to determine viral foci. However, if the cell layer is not dense enough, the cells will detach and the staining will not work properly. If you have problems when performing the immunofocus assay, a possibility could be to change the cell number. Another option could be to change the incubation time; however, you should incubate the cells for at least 48 h.
11. If the cells detach very easily, you can also take off the supernatant with the pipette.
12. To obtain a nicer result for the staining of viral foci prepare the 4 % PFA solution yourself and do not use the ready-to-use Formafix solution.
13. Although you are working with propagation-incompetent rLCMV vectors avoid aerosol formation by flicking off the supernatant into the sink. It is better to dispose the supernatant into a special waste box.
14. Titrate the rat- α -LCMV antibody for a good staining of viral foci. Another possibility is to directly use the supernatant of

hybridoma cells (VL-4) producing the α -LCMV antibody (European Virus Archive, EVA). Dilute the supernatant containing the α -LCMV antibody in DMEM according to the antibody concentration in your supernatant.

15. The viral titer (foci that are stained with rat- α -LCMV antibody) does not allow conclusions concerning the expression of the antigen. In addition you can stain for the expression of your inserted antigen if good antibodies are available and determine the foci by an immunofocus assay. Furthermore you can determine the expression of your antigen in vitro for instance with quantitative PCR (qPCR), Western blot, or FACS analysis.
16. To get higher viral titers you can use FreeStyle 293-F cells (Life Technologies) and transfect them with the plasmid M369 that expresses a codon-optimized LCMV-GP cDNA as described for the BHK-21-GP and 293T-GP cell lines [15]. These cells demonstrate high transfection efficiencies. They grow as a suspension culture in serum-free conditions and permit the infection of cells at large volumes. After harvesting the viral vectors you can concentrate them by applying tangential flow filtration, Centrifugal Filter Units (Millipore), or a sucrose gradient. However, you have to find out the most efficient method according to your needs.
17. The induced CTL response can vary for different routes of immunization (e.g., intravenous, intraperitoneal, or subcutaneous) and for different antigens (e.g., foreign antigens versus self-antigens).
18. It is recommended to determine the kinetics of the induced antigen-specific CTL response after immunization with the rLCMV vectors because the peak of the T cell response may be variable for different antigen. As a control you can stain for the induction of a LCMV-specific T cell response (e.g., for NP₃₉₆₋₄₀₄-specific CD8⁺ T cells).
19. Take care to avoid hyperthermia and dehydration of the mice.
20. The conditions for the tetramer staining vary between different tetramers. Therefore, it is recommended to try different conditions (e.g., temperature, and incubation time) for your tetramers to obtain stable and reliable stainings.

References

1. Zingernagel RM (2002) Lymphocytic choriomeningitis virus and immunology. *Curr Top Microbiol Immunol* 263:1–5
2. Zhou X, Ramachandran S, Mann M et al (2012) Role of lymphocytic choriomeningitis virus (LCMV) in understanding viral immunology: past, present and future. *Viruses* 4:2650–2669
3. Armstrong C, Lillie RD (1934) Experimental lymphocytic choriomeningitis of monkeys and

- mice produced by a virus encountered in studies of the 1993 St. Louis encephalitis epidemic. *Public Health Rep* 49:1019–1027
4. Fischer SA, Graham MB, Kuehnert MJ et al (2006) Transmission of lymphocytic choriomeningitis virus by organ transplantation. *N Engl J Med* 354:2235–2249
 5. Bonthius DJ, Perlman S (2007) Congenital viral infections of the brain: lessons learned from lymphocytic choriomeningitis virus in the neonatal rat. *PLoS Pathog* 3, e149
 6. Barton LL, Mets MB (2001) Congenital lymphocytic choriomeningitis virus infection: decade of rediscovery. *Clin Infect Dis* 33:370–374
 7. Buchmeier MJ, Bowen MD, Peter CJ (2001) Arenaviridae: the viruses and their replication. In: Knipe DM, Howley PM (eds) *Fields virology*. Lippincott Williams & Wilkins, Philadelphia, PA, pp 1635–1668
 8. Hangartner L, Zinkernagel RM, Hangartner H (2006) Antiviral antibody responses: the two extremes of a wide spectrum. *Nat Rev Immunol* 6:231–243
 9. Lee KJ, Perez M, Pinschewer DD et al (2002) Identification of the lymphocytic choriomeningitis virus (LCMV) proteins required to rescue LCMV RNA analogs into LCMV-like particles. *J Virol* 76:6393–6397
 10. Pinschewer DD, Perez M, Sanchez AB et al (2003) Recombinant lymphocytic choriomeningitis virus expressing vesicular stomatitis virus glycoprotein. *Proc Natl Acad Sci U S A* 100:7895–7900
 11. Flatz L, Bergthaler A, de la Torre JC et al (2006) Recovery of an arenavirus entirely from RNA polymerase I/II-driven cDNA. *Proc Natl Acad Sci U S A* 103:4663–4668
 12. Sanchez AB, de la Torre JC (2006) Rescue of the prototypic Arenavirus LCMV entirely from plasmid. *Virology* 350:370–380
 13. Emonet SF, Garidou L, McGavern DB et al (2009) Generation of recombinant lymphocytic choriomeningitis viruses with trisegmented genomes stably expressing two additional genes of interest. *Proc Natl Acad Sci U S A* 106:3473–3478
 14. Flatz L, Hegazy AN, Bergthaler A et al (2010) Development of replication-defective lymphocytic choriomeningitis virus vectors for the induction of potent CD8+ T cell immunity. *Nat Med* 16:339–345
 15. Matter M, Pavelic V, Pinschewer DD et al (2007) Decreased tumor surveillance after adoptive T-cell therapy. *Cancer Res* 67:7467–7476
 16. Homann D, Teyton L, Oldstone MB (2001) Differential regulation of antiviral T-cell immunity results in stable CD8+ but declining CD4+ T-cell memory. *Nat Med* 7:913–919
 17. Battegay M, Cooper S, Althage A et al (1991) Quantification of lymphocytic choriomeningitis virus with an immunological focus assay in 24- or 96-well plates. *J Virol Methods* 3:191–198
 18. Ortiz-Riano E, Cheng BY, de la Torre JC et al (2013) Arenavirus reverse genetics for vaccine development. *J Gen Virol* 94:1175–1188

Production of Japanese Encephalitis Virus-Like Particles Using Insect Cell Expression Systems

Hideki Yamaji and Eiji Konishi

1 Introduction

1.1 Virus-Like Particles (VLPs) and Insect Cell Expression Systems

Structural viral proteins such as envelope and capsid proteins self-assemble into particulate structures similar to authentic virus particles or naturally occurring subviral particles. Based on this characteristic, the expression of such viral surface proteins in heterologous systems using recombinant DNA technology allows the production of VLPs [1–5]. VLPs are non-infectious and non-replicating because they are formed without incorporation of either the DNA or RNA of the virus. VLPs can induce strong humoral and cellular immune responses because of their densely repetitive display of viral antigens in an authentic conformation [1–5]. Therefore, VLPs offer a promising platform for the development of safe and efficacious vaccines and diagnostic antigens.

VLPs can be rapidly manufactured on a large scale using recombinant protein production systems. A variety of expression systems, including bacterial, yeast, insect, mammalian, and plant cell systems and in vitro cell-free systems, are generally available for the production of recombinant proteins [5, 6]. Among them, the baculovirus–insect cell system has been employed extensively in the production of VLPs and subunit vaccines [4–11]. In the typical baculovirus–insect cell system, a recombinant nucleopolyhedrovirus (NPV) is generated, wherein the polyhedrin gene is replaced with a foreign gene of interest. The promoter for the polyhedrin gene is extremely strong, whereas the polyhedrin gene is essential neither for the infection nor for the replication of a baculovirus. Consequently, the infection of cultured lepidopteran insect cells, such as *Spodoptera frugiperda* Sf9 cells and *Trichoplusia ni* BTI-TN-5B1-4 (High Five) cells, with a recombinant baculovirus often leads to the expression of large quantities of foreign protein under the control of the polyhedrin promoter during the very late

phase of infection. Host insect cells perform most of the posttranslational processing and modifications of higher eukaryotes [12]. The baculovirus–insect cell system is not hazardous to humans since baculoviruses are nonpathogenic to vertebrates and plants. In addition, insect cells do not support the growth of mammalian viruses (except for arboviruses) or mycoplasmas. Insect cells easily grow to a high cell density in suspension culture with a serum-free or animal-derived component-free medium. A human papillomavirus-like particle vaccine that has been approved for the prevention of cervical cancers is manufactured on an industrial scale using the baculovirus–insect cell system [8, 9, 13]. This system is also employed for the manufacture of a seasonal influenza vaccine that has been approved for use in the USA, and consists of recombinant hemagglutinin [9, 14]. The latter vaccine is not based on VLPs, but these examples demonstrate that insect cells can be a practical platform for the large-scale production of recombinant protein vaccines.

The baculovirus–insect cell system allows for attractive “plug and play” production where a single approved insect cell line can be used for the manufacture of different antigen proteins [9]. In the production of VLPs, however, the contamination of progeny baculoviruses released from infected insect cells can become a critical problem [5, 8, 10]. The release of intracellular proteins from lysed cells can result in the proteolytic degradation of products and can also complicate the downstream processing and purification of products. Stably transformed insect cells can be used as attractive alternative platforms for the baculovirus–insect cell system [11, 15–22]. For the construction of stably transformed insect cells, host insect cells are transfected with a plasmid vector, into which a gene of interest is cloned under the control of an appropriate promoter, as in the case of mammalian cells. If the introduced vector integrates into the chromosomal DNA of the host cell, the protein of interest can be synthesized either constitutively or upon induction. To facilitate the selection of a small fraction of transformed cells, an antibiotic resistance gene, carried either on the same plasmid as the gene of interest or on a separate plasmid, is introduced into host cells with the gene of interest. The stably transformed insect cells are particularly useful for the production of complex secreted and membrane-bound proteins, because the protein synthesis and processing machinery of the host insect cell is not damaged by baculovirus infection. This chapter describes the procedure that is used to produce Japanese encephalitis (JE) VLPs from stably transformed lepidopteran insect cells. For the production of JE VLPs using the baculovirus–insect cell system, please refer to the literature references [23, 24]. The strategy described in this chapter would be applicable to other flaviviruses such as dengue and West Nile viruses [25, 26].

1.2 Production of JE VLPs

JE is a serious disease caused by the JE virus (JEV). It is widespread throughout Asian countries, but effective vaccines are available to prevent JE. JEV belongs to the genus *flavivirus*, which includes many important human pathogens such as dengue, West Nile, and yellow fever viruses [27]. The flavivirus particle has a nucleocapsid structure surrounded by a lipid bilayer containing an envelope glycoprotein (E) and a membrane protein (M) [28–32] (Fig. 1a). The E protein is the major surface protein that plays a role in cellular receptor binding and membrane fusion. It induces neutralizing antibodies that protect hosts against disease. The M protein is synthesized as the precursor membrane protein (prM) in infected

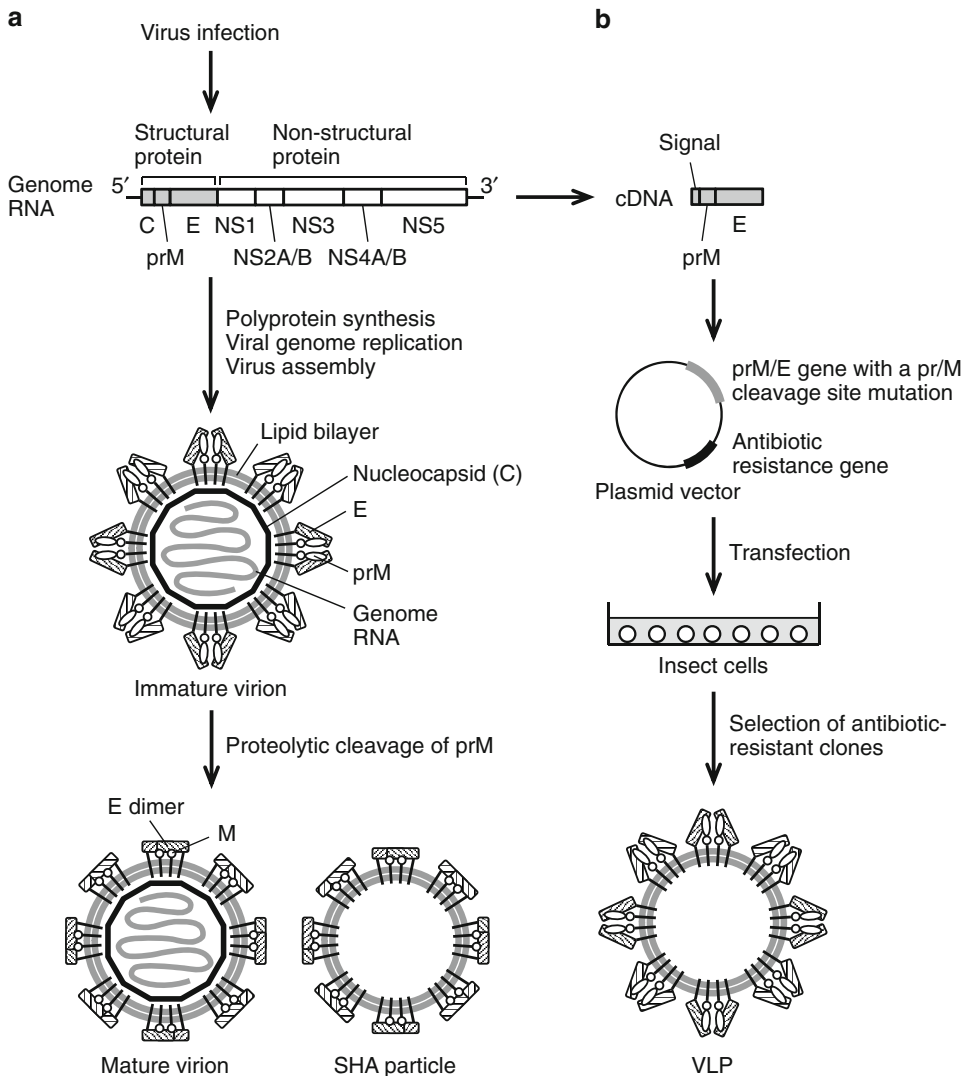

Fig. 1 Schematic representation of flavivirus virion formation in infected cells (a) and production of virus-like particles (VLPs) in recombinant insect cells (b). SHA, slowly sedimenting hemagglutinin. Reproduced from Ref. [11] by permission of Springer

cells. The prM protein is then cleaved to M by a cellular protease, furin, during the virion maturation process. This cleavage event causes the rearrangement of E proteins from a prM/E heterodimer to an E homodimer on virus particles, which is the preliminary process in the formation of mature virions that can induce host-cell fusion, making them infectious (Fig. 1a).

Nucleocapsid-free subviral particles containing E and M proteins, known as slowly sedimenting hemagglutinin (SHA) particles, are the natural by-products of flavivirus assembly and are released from infected cells [28–30] (Fig. 1a). Coexpression of the prM and E proteins has been known to lead to the formation and secretion of recombinant subviral particles without nucleocapsids that can be used as an immunogen with protective capabilities [28–30]. In order to generate a mammalian cell line that can continuously produce a secreted form of JE VLPs, CHO cells were transfected with the JEV prM and E genes, but stable expression cell lines were not obtained due to the toxic cell-fusing ability of VLPs that contained E and M proteins [33]. By contrast, a stable CHO cell line secreting JE VLPs was successfully established by transfecting the E gene and a DNA fragment encoding a mutated form of prM containing a modification of the amino acid sequence at the pr/M cleavage site. Biochemical alteration of the prM protein is critical for the successful generation of a JE VLP-producing mammalian cell line [33], though exceptions have also been reported [34, 35]. Nevertheless, the yields of the E protein produced by the recombinant CHO cells have not been sufficient to meet the requirements of practical application.

Expression systems using lepidopteran insect cells, such as Sf9 and High Five cells, can be employed for the efficient production of JE VLPs. A secreted form of JE VLPs has been produced using Sf9 insect cells following infection with a recombinant baculovirus that contains the JEV authentic prM gene and the E gene downstream of the polyhedrin promoter [23]. Baculovirus-infected Sf9 cells have produced yields of E antigen that are more than tenfold higher than that obtained using previously reported recombinant CHO cells. The polyhedrin promoter may direct high levels of foreign gene expression even for toxic proteins in infected insect cells, because it is highly active during the very late phase of infection when gene expression is primarily virus-specific. On the other hand, High Five cells were stably transformed via the use of a powerful plasmid vector carrying the JEV prM and E genes [22]. The use of DNA encoding a form of prM with a pr/M cleavage site mutation led to a considerably higher yield of E protein than that obtained with the baculovirus–insect cell system [22, 36]. Transient expression experiments showed that the use of the mutated prM gene was favorable even in lepidopteran insect cells, while the cytotoxicity of JEV proteins against insect cells may be lower than it is against mammalian cells because JEV is an

insect-borne virus. VLPs recovered from the culture supernatant from recombinant High Five cells successfully induced neutralizing antibodies in mice [22]. Based on the evidence, lepidopteran insect cell expression systems may offer a promising approach to the efficient production of mammalian virus proteins including VLPs for use as vaccines and diagnostic antigens.

2 Materials

1. Insect cells: *T. ni* BTI-TN-5B1-4 (High Five) are obtained from Life Technologies (Carlsbad, CA, USA).
2. Culture medium: Express Five SFM (serum-free medium) (Life Technologies) supplemented with 16.5 mM L-glutamine (*see Note 1*).
3. Plasmid vectors: The pIB and pIZ vectors are available from Life Technologies. These vectors contain the OpIE2 promoter from *Orgyia pseudotsugata* NPV (OpNPV) for the constitutive expression of a gene of interest and either the blasticidin resistance gene or the Zeocin resistance gene for the selection of stable cell lines. The pIEx series and the pIE1-neo are available from EMD Millipore (Billerica, MA, USA). The pIEx vectors contain the *Autographa californica* NPV (AcNPV) HR5 enhancer and the AcNPV IE-1 promoter for high-level constitutive expression (*see Subheading 3.1*) but no antibiotic resistance gene. By cotransfecting the pIE1-neo with the pIEx and selecting with G418, a stable cell line can be generated.
4. TE buffer, pH 8.0: 10 mM Tris-HCl and 1 mM EDTA at pH 8.0.
5. Transfection reagent: FuGENE 6 transfection reagent (Promega, Madison, WI, USA).
6. Antibiotics for the selection of transformed cells: blasticidin for the blasticidin resistance gene and Zeocin for the Zeocin resistance gene (InvivoGen, San Diego, CA, USA). G418 for the pIE1-neo and the pIEx (InvivoGen).
7. Sterile 96-well tissue culture plates.
8. Sterile 12-well tissue culture plates.
9. Sterile 6-well tissue culture plates.
10. Sterile 100-mm tissue-culture dishes.
11. Sterile tissue-culture flasks (25 and 75 cm²).
12. Sterile microcentrifuge tubes (1.5 mL).
13. Sterile centrifuge tubes (15 mL).
14. Sterile pipets (5 or 10 mL).
15. Glass cloning cylinders.
16. Silicon grease.

17. Glass petri dish.
18. Stainless steel tweezers.
19. Micropipettes and sterile tips.
20. Non-humidified incubator capable of maintaining a temperature of 27 °C (*see Note 2*).
21. Laminar flow hood.
22. Autoclave.
23. Centrifuge and a swing-bucket rotor.
24. Vortex mixer.

3 Methods

3.1 Transfection

Lepidopteran insect cells such as Sf9 cells and High Five cells have been used for stable transformation. High Five cells have proved to be an excellent host for the production of recombinant secreted proteins [16, 17, 20].

Prior to transfection, the gene of interest is cloned into a plasmid vector under the control of a promoter. A constitutively active promoter is generally used for lepidopteran insect cells. The choice of a promoter to drive the heterologous gene expression is important, as the use of a weak promoter results in low yields of recombinant protein [21]. The activity of a promoter used in lepidopteran insect cells can be enhanced by certain *cis*- or *trans*-acting elements that are derived from baculoviruses [18, 19]. The AcNPV HR5 enhancer has been used to stimulate AcNPV IE-1 promoter-mediated transcription [19, 37]. The pIEx vectors containing the HR5 enhancer and the IE-1 promoter are commercially available (*see* Subheading 2, item 3). By cotransfection of the pIEx vector with the pIE1-neo and selection with G418, a stable cell line can be generated. A high-level expression vector pIE1/153A containing the *Bombyx mori* cytoplasmic actin promoter, from which foreign gene expression is stimulated with the *B. mori* NPV (BmNPV) IE-1 transactivator and the BmNPV HR3 enhancer, has been developed for lepidopteran insect cells [15–17]. The use of the IE-1 transactivator and the HR3 enhancer allows a more than 1000-fold increase in the stimulation of foreign gene expression through the actin promoter [38]. The pIE1/153A does not contain a selection marker for selecting stable cell lines.

Coexpression of the JEV prM and E genes together with the prM signal sequence leads to the successful production of a secretory form of VLPs. The flavivirus prM signal sequence is a transmembrane signal located adjacent to the prM that directs the translocation of the prM into the lumen of the ER from its synthesis site on the surface of the ER [29, 39, 40]. Rather than being secreted, E protein reportedly accumulates in the cytoplasm of Sf9 cells infected with

recombinant baculoviruses encoding JEV E protein with an N-terminal signal sequence derived from its adjacent prM [41]. By contrast, when CHO cells [33] and High Five cells [22] are transfected with the JEV prM signal sequence (57 bp adjacent to prM), the mutated prM gene, and the E gene, they produce a secreted form of VLPs that contain E and prM proteins (Fig. 1b). Instead of the JEV prM signal sequence, the *Drosophila* BiP signal sequence can be used for the successful secretory production of JE VLPs [36].

Please use the general molecular biology techniques and methods, as described by Sambrook and Russell [42]. See also the protocol recommended by the manufacturer of the plasmid vector of choice and transfection reagent. All handling of insect cells should be carried out under sterile conditions in a laminar flow hood. For guidelines and detailed information on insect cell cultures, please refer to the literature references [43–45].

1. Clone the DNA fragment encoding the JEV prM signal sequence and the prM and E genes into the plasmid vector of choice using either restriction enzyme digestion and ligation or other appropriate techniques. Isolate the plasmid DNA and analyze for the inserted element.
2. Prepare the plasmid DNA in TE buffer at a final concentration of 0.2–1 mg/mL for transfection into insect cells. The plasmid DNA must be very clean and free from contaminants that interfere with transfection.
3. Collect High Five cells in the exponential growth phase with >95 % viability into a 15-mL centrifuge tube. Centrifuge the cell suspension at $<500 \times g$ for 3–5 min, and discard the supernatant. Resuspend the cells at 1×10^5 cells/mL in fresh medium that does not contain antibiotics (*see Note 3*).
4. Add 2 mL of the cell suspension in each well of a 6-well tissue culture plate. Incubate the cells for 24 h at 27 °C in an incubator.
5. For each transfection sample, add 6 μ L FuGENE 6 transfection reagent and 1 μ g plasmid DNA to 94 μ L fresh medium without antibiotics in a 1.5-mL microcentrifuge tube. Mix by vortexing briefly and incubate for 15 min at room temperature.
6. Add the mixture to each well of the cells to be transfected.
7. Incubate the cells at 27 °C in an incubator. When testing for gene expression or optimizing transfection conditions, incubate the cells for 3–5 days and analyze the cell-culture supernatant for the expression of E protein by western blotting and enzyme-linked immunosorbent assay (ELISA). Prior to stable transformation, optimization of the transfection conditions is recommended, which include the transfection reagent–DNA ratio, amount of DNA used, and incubation time after mixing the transfection reagent with the DNA.

3.2 **Stable Transformation**

Once the E protein secretion from the transfected High Five cells has been confirmed, stably transformed cell lines can be generated for long-term storage and large-scale production of VLPs.

1. Prepare selective medium by supplementing Express Five SFM with 16.5 mM L-glutamine and either blasticidin, Zeocin, or G418 at the appropriate concentration. The use of a drug concentration that will kill cells within a week is recommended. Different concentrations of drugs should be tested in order to determine a concentration that will kill cells within a week (*see Note 4*).
2. Follow the transfection procedure described in Subheading 3.1, **steps 1–6**. When the gene of interest is cloned in a plasmid vector without a selection marker, including the pIEx vector, cotransfect the expression vector with a plasmid containing an antibiotic resistance gene, such as the pIE1-neo (*see Subheading 3.1*)
3. Incubate the cells for 48 h at 27 °C in an incubator.
4. Dislodge the cells from each well and resuspend them at 1×10^5 cells/mL in 10 mL fresh medium. Transfer the cell suspension into a 100-mm tissue culture dish. Incubate the cells at 27 °C in an incubator.
5. Following 24-h incubation, remove the medium and replace it with selective medium. Incubate the cells at 27 °C in an incubator.
6. Replace selective medium every 3–4 days until distinct colonies can be visualized. Isolate clonal cell lines using cloning cylinders as follows (*see Note 5*). Sterilize the cloning cylinders and the silicon grease together in a glass petri dish by autoclaving. Using flame-sterilized tweezers, dip one end of a sterile cloning cylinder into grease on the petri dish. Remove the culture medium and place the cylinder firmly around a well-isolated colony. Add 100 μ L of fresh medium without drugs to the inside of the cylinder. Using a micropipette, gently disperse the cells from the colony. Transfer the cells and the medium to each well of a 96-well tissue culture plate. Work quickly to prevent the cells from drying. Incubate the cells for 24 h at 27 °C in an incubator. Instead of using cloning cylinders, limiting dilution can be employed to isolate clonal cell lines. Otherwise, to isolate a polyclonal cell line, let the resistant cells grow to confluency in the 100-mm culture dish. *See [19]* and the protocol recommended by the manufacturer of the plasmid vector of choice.
7. Following 24 h of incubation, remove the medium and replace it with selective medium. Check the cells daily under an inverted microscope. Transfer the cells that have reached approximate confluency to each well of a 12-well plate. Allow the cells to grow close to confluency. Analyze the cell-culture supernatant for the expression of E protein by western blotting

and ELISA. Screen highly productive cell lines and transfer the cells to 25-cm² tissue-culture flasks (*see* **Note 6**). Expand the cells into 75-cm² flasks to prepare frozen stock.

8. To check whether secreted E proteins are in a particulate form, fractionate the culture supernatant from stably transformed cells via sucrose density-gradient centrifugation, and determine the E protein concentration in each fraction via ELISA [22, 33].

3.3 Production of VLPs

Once stably transformed cell lines have been obtained and frozen stocks of the cell lines have been prepared, the cells should be cultured in larger flasks, spinner flasks, shake flasks, or bioreactors to produce VLPs. Insect cells can be grown to high densities in suspension cultures. A higher recombinant protein yield is often achieved in a shake-flask culture compared with a static culture, probably due to the better oxygen supply in a shake-flask culture [20, 22].

4 Notes

1. Supplementing the medium with 10 mg/L gentamicin sulfate is recommended for a routine cell culture. Serum-free media such as PFM-J1 Medium Wako (Wako Pure Chemical Industries, Osaka, Japan) and Cosmedium 009X (Cosmo Bio, Tokyo, Japan) are also available.
2. Lepidopteran insect cells are maintained at around 27 °C without CO₂ supplementation in the atmosphere. When using a humidity-controlled incubator, tissue-culture dishes are available without desiccation of a culture medium.
3. Using antibiotics in the transfection medium is not recommended, because antibiotics may adversely affect the transfection efficiency.
4. Generally, 10–20 µg/mL blasticidin will kill High Five cells within a week in Express Five SFM. Zeocin concentrations that kill lepidopteran insect cells reside in the 200–600 µg/mL range. Concentrations of approximately 700 µg/mL G418 will kill High Five cells in Express Five SFM within 2–3 weeks. When maintaining stable lepidopteran cell lines, lower the concentration of blasticidin to 10 µg/mL, Zeocin to 50 µg/mL, and G418 to 300 µg/mL, respectively. Refer to the protocol recommended by the manufacturer of the plasmid vector of choice.
5. To obtain highly productive clonal cell lines, attempt to isolate as many colonies as possible for the expression testing. As in mammalian cell cultures, the integration location in the chromosomal DNA of the host cell, and the number of integrated genes may affect the expression of a target gene.
6. Cells should not be inoculated at low densities (<1 × 10⁵ cells/mL).

References

1. Noad R, Roy P (2003) Virus-like particles as immunogens. *Trends Microbiol* 11:438–444
2. Grgacic EVL, Anderson DA (2006) Virus-like particles: passport to immune recognition. *Methods* 40:60–65
3. Roy P, Noad R (2008) Virus-like particles as a vaccine delivery system: myths and facts. *Hum Vaccin* 4:5–8
4. Kang SM, Song JM, Quan FS, Compans RW (2009) Influenza vaccines based on virus-like particles. *Virus Res* 143:140–146
5. Kushnir N, Streatfield SJ, Yusibov V (2012) Virus-like particles as a highly efficient vaccine platform: diversity of targets and production systems and advances in clinical development. *Vaccine* 31:58–83
6. Zeltins A (2013) Construction and characterization of virus-like particles: a review. *Mol Biotechnol* 53:92–107
7. van Oers MM (2006) Vaccines for viral and parasitic diseases produced with baculovirus vectors. *Adv Virus Res* 68:193–253
8. Vicente T, Roldão A, Peixoto C, Carrondo MJT, Alves PM (2011) Large-scale production and purification of VLP-based vaccines. *J Invertebr Pathol* 107:S42–S48
9. Cox MMJ (2012) Recombinant protein vaccines produced in insect cells. *Vaccine* 30:1759–1766
10. Fernandes F, Teixeira AP, Carinhas N, Carrondo MJT, Alves PM (2013) Insect cells as a production platform of complex virus-like particles. *Expert Rev Vaccines* 12:225–236
11. Yamaji H (2014) Suitability and perspectives on using recombinant insect cells for the production of virus-like particles. *Appl Microbiol Biotechnol* 98:1963–1970
12. Luckow VA (1995) Protein production and processing from baculovirus expression vectors. In: Shuler ML, Wood HA, Granados RR, Hammer DA (eds) *Baculovirus expression systems and biopesticides*. Wiley-Liss, New York, NY, pp 51–90
13. Schiller JT, Castellsagué X, Garland SM (2012) A review of clinical trials of human papillomavirus prophylactic vaccines. *Vaccine* 30S:F123–F138
14. Buckland B, Boulanger R, Fino M, Srivastava I, Holtz K, Khramtsov N, McPherson C, Meghroun J, Kubera P, Cox MMJ (2014) Technology transfer and scale-up of the Flublok recombinant hemagglutinin (HA) influenza vaccine manufacturing process. *Vaccine* 32:5496–5502
15. Farrell PJ, Lu M, Prevost J, Brown C, Behie L, Iatrou K (1998) High-level expression of secreted glycoproteins in transformed lepidopteran insect cells using a novel expression vector. *Biotechnol Bioeng* 60:656–663
16. Farrell PJ, Behie LA, Iatrou K (1999) Transformed lepidopteran insect cells: new sources of recombinant human tissue plasminogen activator. *Biotechnol Bioeng* 64:426–433
17. Keith MB, Farrell PJ, Iatrou K, Behie LA (1999) Screening of transformed insect cell lines for recombinant protein production. *Biotechnol Prog* 15:1046–1052
18. Douris V, Swevers L, Labropoulou V, Andronopoulou E, Georgoussi Z, Iatrou K (2006) Stably transformed insect cell lines: tools for expression of secreted and membrane-anchored proteins and high-throughput screening platforms for drug and insecticide discovery. *Adv Virus Res* 68:113–156
19. Harrison RL, Jarvis DL (2007) Transforming lepidopteran insect cells for continuous recombinant protein expression. In: Murhammer DW (ed) *Baculovirus and insect cell expression protocols*, 2nd edn, *Methods in molecular biology*, vol 388. Humana, Totowa, NJ, pp 299–315
20. Yamaji H, Manebe T, Watakabe K, Muraoka M, Fuji I, Fukuda H (2008) Production of functional antibody Fab fragment by recombinant insect cells. *Biochem Eng J* 41:203–209
21. Yamaji H (2011) Production of antibody in insect cells. In: Al-Rubeai M (ed) *Antibody expression and production, Cell engineering*, vol 7. Springer Science+Business Media, Dordrecht, pp 53–76
22. Yamaji H, Nakamura M, Kuwahara M, Takahashi Y, Katsuda T, Konishi E (2013) Efficient production of Japanese encephalitis virus-like particles by recombinant lepidopteran insect cells. *Appl Microbiol Biotechnol* 97:1071–1079
23. Yamaji H, Segawa M, Nakamura M, Katsuda T, Kuwahara M, Konishi E (2012) Production of Japanese encephalitis virus-like particles using the baculovirus–insect cell system. *J Biosci Bioeng* 114:657–662
24. Furuta T, Ogawa T, Yamaji H (2012) Production of antibody fragments using the baculovirus–insect cell system. In: Chames P (ed) *Antibody engineering: methods and protocols*, 2nd edn, *Methods in molecular biology*, vol 907. Springer Science+Business Media, Dordrecht, pp 371–387
25. Konishi E, Fujii A (2002) Dengue type 2 virus subviral extracellular particles produced by a stably transfected mammalian cell line and their

- evaluation for a subunit vaccine. *Vaccine* 20:1058–1067
26. Kuwahara M, Konishi E (2010) Evaluation of extracellular subviral particles of dengue virus type 2 and Japanese encephalitis virus produced by *Spodoptera frugiperda* cells for use as vaccine and diagnostic antigens. *Clin Vaccine Immunol* 17:1560–1566
 27. Ishikawa T, Yamanaka A, Konishi E (2014) A review of successful flavivirus vaccines and the problems with those flaviviruses for which vaccines are not yet available. *Vaccine* 32:1326–1337
 28. Heinz FX, Allison SL (2003) Flavivirus structure and membrane fusion. *Adv Virus Res* 59:63–97
 29. Mukhopadhyay S, Kuhn RJ, Rossmann MG (2005) A structural perspective of the *flavivirus* life cycle. *Nat Rev Microbiol* 3:13–22
 30. Stiasny K, Heinz FX (2006) Flavivirus membrane fusion. *J Gen Virol* 87:2755–2766
 31. Li L, Lok S-M, Yu I-M, Zhang Y, Kuhn RJ, Chen J, Rossmann MG (2008) The flavivirus precursor membrane-envelope protein complex: structure and maturation. *Science* 319:1830–1834
 32. Yu I-M, Zhang W, Holdaway HA, Li L, Kostyuchenko VA, Chipman PR, Kuhn RJ, Rossmann MG, Chen J (2008) Structure of the immature dengue virus at low pH primes proteolytic maturation. *Science* 319:1834–1837
 33. Konishi E, Fujii A, Mason PW (2001) Generation and characterization of a mammalian cell line continuously expressing Japanese encephalitis virus subviral particles. *J Virol* 75:2204–2212
 34. Kojima A, Yasuda A, Asanuma H, Ishikawa T, Takamizawa A, Yasui K, Kurata T (2003) Stable high-producer cell clone expressing virus-like particles of the Japanese encephalitis virus E protein for a second-generation subunit vaccine. *J Virol* 77:8745–8755
 35. Davis BS, Chang GJJ, Cropp B, Roehrig JT, Martin DA, Mitchell CJ, Bowen R, Bunning ML (2001) West Nile virus recombinant DNA vaccine protects mouse and horse from virus challenge and expresses in vitro a noninfectious recombinant antigen that can be used in enzyme-linked immunosorbent assays. *J Virol* 75:4040–4047
 36. Yamaji H, Konishi E (2013) Production of Japanese encephalitis virus-like particles in insect cells. *Bioengineered* 4:438–442
 37. Jarvis DL, Weinkauff C, Guarino LA (1996) Immediate-early baculovirus vectors for foreign gene expression in transformed or infected insect cells. *Protein Expr Purif* 8:191–203
 38. Lu M, Farrell PJ, Johnson R, Iatrou K (1997) A baculovirus (*Bombyx mori* nuclear polyhedrosis virus) repeat element functions as a powerful constitutive enhancer in transformed insect cells. *J Biol Chem* 272:30724–30728
 39. Lobigs M (1993) Flavivirus premembrane protein cleavage and spike heterodimer secretion require the function of the viral proteinase NS3. *Proc Natl Acad Sci U S A* 90:6218–6222
 40. Huang CYH, Silengo SJ, Whiteman MC, Kinney RM (2005) Chimeric dengue 2 PDK-53/West Nile NY99 viruses retain the phenotypic attenuation markers of the candidate PDK-53 vaccine virus and protect mice against lethal challenge with West Nile virus. *J Virol* 79:7300–7310
 41. Wu SC, Lin YJ, Yu CH (2003) Baculovirus-insect cell expression, purification, and immunological studies of the full-length Japanese encephalitis virus envelope protein. *Enzyme Microb Technol* 33:438–444
 42. Sambrook J, Russell DW (2001) *Molecular cloning: a laboratory manual*, 3rd edn. Cold Spring Harbor Laboratory Press, Cold Spring Harbor, NY
 43. O'Reilly DR, Miller LK, Luckow VA (1994) *Baculovirus expression vectors. A laboratory manual*. Oxford University Press, New York, NY
 44. Murhammer DW (ed) (2007) *Baculovirus and insect cell expression protocols*, 2nd edn, *Methods in molecular biology*, vol 388. Humana, Totowa, NJ
 45. *Growth and maintenance of insect cell lines. User guide*. Life Technologies, Carlsbad, CA

Subunit Protein Vaccine Delivery System for Tuberculosis Based on Hepatitis B Virus Core VLP (HBc-VLP) Particles

Dhananjayan Dhanasooraj, R. Ajay Kumar, and Sathish Mundayoor

1 Introduction

Tuberculosis (TB) is the second leading infectious disease by mortality rate. The disease is caused by the bacterium *Mycobacterium tuberculosis* (Mtb). TB primarily affects the respiratory system resulting in Pulmonary Tuberculosis, but it has also extrapulmonary targets. According to latest estimates, globally 9.0 million new cases are reported annually and 1.5 million deaths due to TB were reported in 2013 alone. TB is prevalent across the globe with South-East Asia and Western Pacific Regions accounting for 56 % of the cases and the African region contributing another quarter. Among different nations, India and China have the largest number of disease cases [1].

Mtb is characterized by slow growth, complex cell envelope, intracellular pathogenesis, slow generation time (~24 h for the organism in synthetic medium or in infected animals) and has a striking dormancy profile. The bacterial genome of 4.41 Mb base pairs has an uncharacteristically high GC (Guanine + Cytosine) content (~65.9 %) and encodes about 4015 genes [2]. The disease transmission is mainly by inhalation of aerosol containing bacteria which originates from the expectoration of affected individuals. The entry of the bacterium into the human body is mostly by respiratory route and in case of severe infection it can spread to other parts of the body via lymphatic system or blood. About 15 % of patients develop extrapulmonary TB of pleura, lymphatics, bone, genitourinary system, meninges, peritoneum, or skin [3].

Bacille Calmette-Guerin (BCG) has been the only available vaccine for TB for nearly one century but has many drawbacks. As the efficacy of BCG has been shown to vary from zero to 80 %, the

emergence of new and dangerous drug resistant bacteria, calls for urgent measures to find new vaccines. Obviously the availability of an affordable vaccine could help to eliminate the disease burden globally [4]. Even though there have been many ideas to develop new vaccines, most strategies involve mixing more than one selected antigen/epitope from a pathogen and using it as a vaccine. Due to the presence of several antigenic epitopes, these vaccines are expected to generate greater protection when compared to a single antigen. Several putative protective antigens have been identified from *Mycobacterium tuberculosis* (Mtb), the bacteria that cause TB [5, 6]. This type of vaccine where recombinant protein subunit comprising multiple open reading frames strung together is both simple and cost effective and these fusion vaccines can be more immunogenic than the individual components. Such hybrid protein vaccines consisting of mycobacterial proteins such as Mtb39 and Mtb32 (Mtb72F), or Ag85B and ESAT-6 (Hybrid-1) [7], the polyprotein of ESAT-6 and Ag85A have shown to be promising in different studies [8]. Both Mtb72F and Hybrid-1 in selected adjuvants have shown protective level of immune response generation in the mouse and guinea pig TB challenge models [8–11]. Thus even though these subunit vaccines are safe and economic, the major hurdle for a successful TB vaccine is the requirement for a proper adjuvant and delivery systems.

Particulate antigen delivery systems have special interest in vaccine research [12, 13]. The method described here use the construction of a vaccine delivery system for tuberculosis subunit vaccine based on Hepatitis B virus core protein VLPs (Virus-like particle) [14]. VLPs are non-infectious, nano-sized particles with broad stability with the capacity to self-assemble. HBc-VLPs can be expressed in most of the known protein expression systems [15–17]. The HBc gene was amplified from genomic DNA of Hepatitis B virus. By using OEPCR (overlap extension PCR) sequences for restriction enzymes and linkers for inserting external antigen in the major immunodominant region (MIR) of HBc gene could be incorporated where required. The modifications were designed in such a way that any external antigen amplified with the sequences incorporated at both ends for the respective restriction endonucleases could easily be inserted inside the MIR region by appropriate restriction digestion. This modified HBc gene was cloned into a pET 32 expression system. Culture filtrate protein 10 (CFP 10), one of the major immunodominant mycobacterial antigen which has been suggested to be a promising vaccine candidate antigen [18, 19] was chosen as the antigen to be inserted. The genomic DNA isolated from *Mycobacterium tuberculosis* H37Rv, the laboratory strain of tuberculosis was used as a template for amplifying the CFP 10 gene. All the molecular manipulations were designed in such a way that the expressed proteins form a fusion of HBc protein

with the external antigen displayed on the MIR region supported by linkers, and the expressed proteins sport a Six-Histidine tag at the C-terminal to assist in downstream purification.

The recombinant plasmids, pET32 carrying HBc-CFP 10 was transformed into *E. coli* JM109 for increasing the quantity of plasmid. The purified plasmids were transformed into *E. coli* BL 21 (DE3) for protein expression and purification. Isopropyl-beta-thiogalactopyranoside (IPTG) was used for the induction of protein expression. After optimizing proper IPTG concentration and time for maximum protein expression, the bacterial cells were pelleted and stored at -80°C till purification. For protein purification, bacterial cells were lysed and protein fraction was first separated by centrifugation. A mild denaturing condition using urea was applied to dissociate the VLP dimer particles. The mild denaturation dissociated VLPs to dimers and exposed the C terminal HIS tag. Dimers could be easily reassembled later. Monomer formation would require stronger denaturing conditions and these are difficult to reassemble.

The solution containing dimers were then bound to a Ni-Silica resin column pre-equilibrated with dissociation buffer. Unbound proteins were washed out using wash buffer, the urea concentration was decreased by washing with washing buffer and proteins were eluted by gravity flow. The eluted protein dimers were desalted, and concentrated and allowed to form VLPs. VLPs were recovered by sucrose density gradient ultracentrifugation. The separated VLP fractions were recovered from density gradient layers and analyzed on Western blot using antibodies against HBc antigen. The formation of HBc-CFP 10 VLPs was characterized further by TEM.

1.1 Amplification of Selected Genes and Construction of Vectors

1.1.1 HBc Gene Modification

Primers labeled CEFP2 and CEHsR were designed to amplify the nucleotides necessary for forming HBc-VLP (149 amino acid encoding region of HBc gene). Both the primers were designed to incorporate restriction enzyme sequences *NdeI* and *XhoI* respectively, to clone the amplified product into pET vector. Based on the nucleotide sequence encoding MIR (Major Immunodominant Region) of HBc gene, additional primers were designed to modify HBc gene. Overlap extension PCR (OEPCR), a variant of PCR technique (Fig. 1) was used for the HBc gene modification and full length Hepatitis B virus core gene (HBc) containing plasmid (HBc-pGEMT) was used as template.

1.1.2 Inserting Modified HBc Gene into the Expression Vector pET32a

The modified HBc gene was cloned into pET 32a expression vector using *NdeI* and *XhoI* restriction enzyme sites (pETMHbC, Fig. 2). The products were sequenced to ensure that the sequences were in frame as expected. *E. coli* strain JM109 cells was used for transformation and the plasmids were isolated.

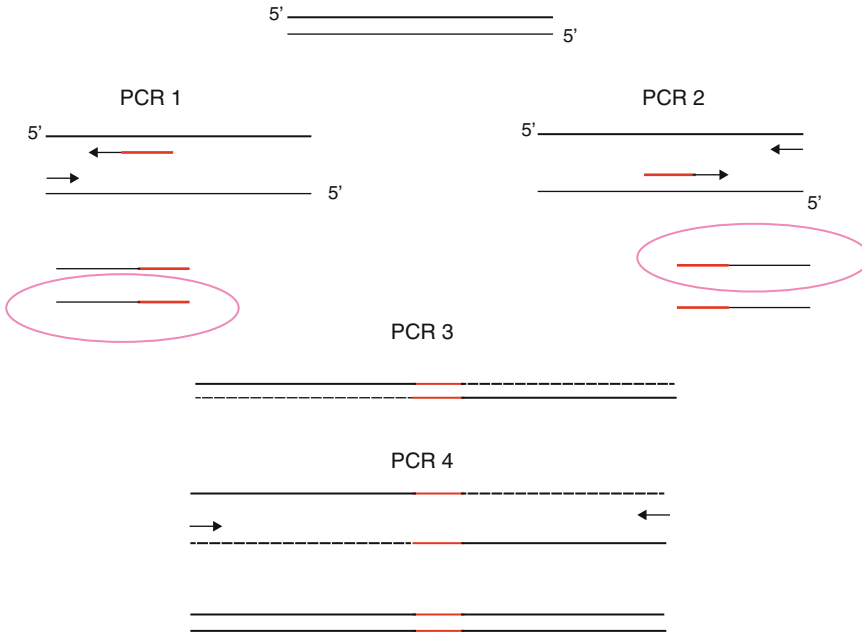

Fig. 1 OEPCR (Overlap extension PCR)

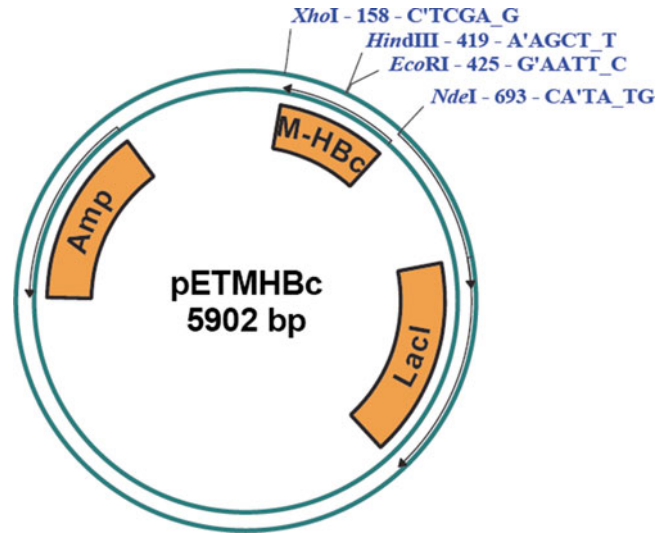

Fig. 2 Modified HBC containing pET plasmid (pETMHBC)

1.1.3 CFP10 Gene Amplification from *Mycobacterium tuberculosis* H37Rv

Genomic DNA from *Mycobacterium tuberculosis* H37Rv was isolated and CFP10 gene was amplified by PCR using the genomic DNA as template. The primers were designed to sport the restriction enzyme sequences on both sides of the amplified product so that this could be inserted into modified HBC gene by restriction digestion followed by ligation.

1.1.4 Construction of Expression Vector for Fusion Protein

The amplified CFP10 gene and modified HBc containing pET32 were digested with enzymes *EcoRI* and *HindIII*. The products were used to clone CFP10 into modified HBc gene in pET32. Thus the resulting vector contained sequences coding for modified HBc carrying CFP10 gene in its MIR region in a single reading frame and sporting a Histidine tag at the C terminal of the expressed protein.

1.2 Expression and Purification of VLP

The vector encoding the modified fusion VLP, generated after ligation reactions were checked by restriction digestion and sequencing. The new vector was then transformed into JM109 cells to increase the plasmid copy number. The plasmid isolated from JM109 was used to transform the expression host *E. coli* BL21 (DE3). The transformed cells were cultured in large volumes and the protein expression was induced by using IPTG after proper bacterial growth. The expressed proteins were separated and VLP dimers were isolated by inducing a mild denaturing condition so that the dimers could be bound to Ni-silica column using His tag binding. The isolated and purified dimers were then allowed to reassemble and VLPs were purified by sucrose density gradient centrifugation.

1.3 Confirmation of Expressed Protein

The content and structure of VLPs were confirmed by Western blot (Fig. 3) and TEM (Fig. 4).

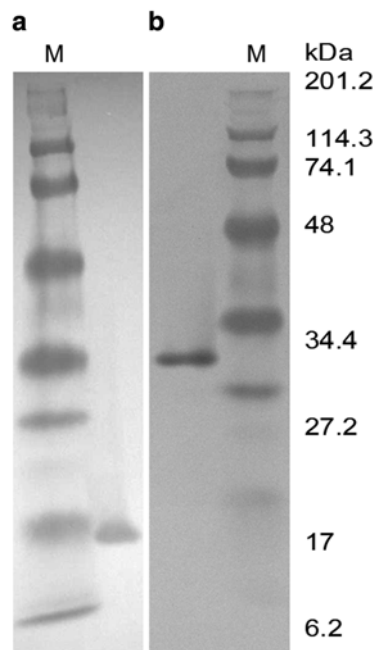

Fig. 3 Western blot of purified proteins. (a) purified HBc probed with anti-HBc antibody; (b) purified FVLP with anti-HBc antibody. M, protein molecular weight marker in kDa

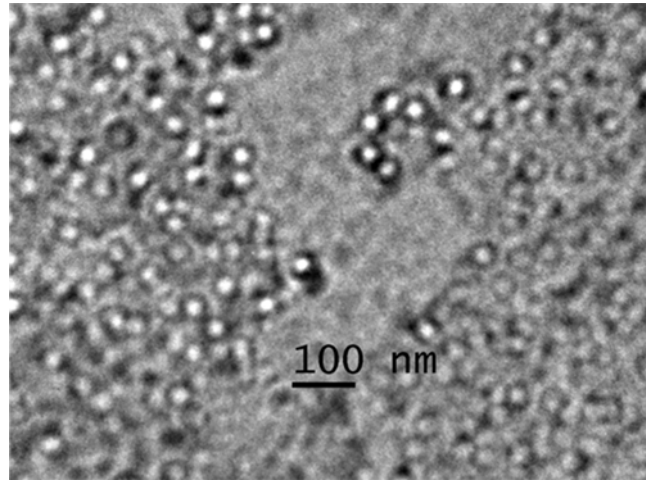

Fig. 4 Transmission electron microscopic pictures of VLPs. FVLP. Bar = 100 nm

2 Materials

2.1 *HBc Amplification and Modification*

1. The study used HBc gene containing vector as template. The amplification of HBc gene also can be obtained from sera purified genomic DNA of HBV (QIAamp DNA Mini Kit, Hilden, Germany).
2. Primer designing software program (Primer Premier [20]).
3. Sequence alignment programs (National Center for Biotechnology (NCBI) Blast online [21], Biology WorkBench SDSC [22]).
4. Taq DNA Polymerase (Sigma-Aldrich, MO, USA), Phusion High-Fidelity DNA Polymerase, 5× Phusion HF Buffer, dNTP mix (10 mM), and MgCl₂ solution (50 mM) (Finnzymes-Thermo Fisher Scientific, Espoo, Finland).
5. PCR machine (iCycler, Bio-Rad, CA, USA).
6. Agarose, DNA loading dye, ethidium bromide, Tris-acetate buffer (TAE).
7. Agarose gel electrophoresis system.
8. Gel documentation system (UVP, CA, USA).
9. Agarose gel band purification kit (Illustra GFX PCR DNA and Gel Band Purification Kit, GE Health care, Little Chalfont, UK).
10. Spectrophotometer (NanoDrop, Thermo Fisher Scientific).
11. CEFP2: GGAATTCCATATGGACATTGACCCTTATAAAGA (Genosys, Sigma).
12. CEHsR: CCGCTCGAGCTAATGGTGATGGTGATGGTGAA CAACAGTAGTCTCCGGAAGTG

13. CMPRP: AAGCTTGGGCCGGAATTCGGTGCCACCGCC ACCAGAGCCACCGCCACCATCTTCCAA
14. CMPFP: GAATTCCGGCCCAAGCTTGGTGGCGGTGGC TCTGGTGGCGGTGGCTCTAGGGAC
15. dNTPs sets (GE Healthcare).
16. Sequencing reaction reagents (Big Dye Terminator Cycle Sequencing Reaction Kit, Applied Biosystems, USA).
17. -20 °C deep freezer (Vest-Frost, Denmark), -70 °C deep freezer (New Brunswick, USA).

2.2 Antigen Amplification from *Mtb*

1. *Mycobacterium tuberculosis* H37Rv genomic DNA.
2. Mcfp10F: CCGGAATTCGCAGAGATGAAGACCGATG
3. Mcfp10R: CCCAAGCTTGAAGCCCATTGCGAGGACAGC

2.3 Clone Antigen into Modified HBc

1. pET32a vector (Novagen).
2. Luria–Bertani broth and agar, Miller (HiMedia Laboratories, Mumbai, India).
3. Ampicillin (Sigma-Aldrich).
4. Culture flasks, tubes and incubators.
5. Plasmid isolation kit (Illustra plasmid Prep Mini Spin Kit, GE Healthcare).
6. Restriction enzymes *NdeI*, *XhoI*, *EcoRI*, *HindIII* and 10× buffers (New England Biolabs, MA, USA).
7. Agarose gel band purification kit (Illustra GFX PCR DNA and Gel Band Purification Kit, GE Health care).
8. T4 DNA Ligase and buffer (Promega, Madison, WI, USA).
9. JM109 endA1, recA1, gyrA96, thi, hsdR17 (rk-, mk+), relA1, supE44, Δ(lac-proAB), [F' traD36, proAB, laqIqZΔM15] (Promega, USA).

2.4 Protein Expression and Purification

1. BL21(DE3) (fhuA2 [lon] ompT gal (λ DE3) [dcm] ΔhsdS λ DE3=λ sBamHIo ΔEcoRI-B int:::(lacI::PlacUV5::T7 gene1) i21 Δnin5) (Novagen, USA).
2. Ultra Yield Flasks (Thomson, California, USA).
3. Sonifier (Branson Ultrasonics, USA).
4. HisLink™ Protein Purification Resin (Promega).
5. D-Tube Dialyzer (Novagen).
6. Antibody: Hep Bc Ag (Santa Cruz Biotechnology, USA).
7. Antibody: Anti-CFP-10 (Thermo Scientific, USA).
8. Bovine serum albumin (BSA), bromophenol blue (BPB), xylene cyanol, 5-bromo-4-chloro-3-indolyl-β-d-galactopyranoside (X-Gal), nitro-blue tetrazolium chloride (NBT), 5-bromo-4-chloro-3'-indolylphosphate *p*-toluidine salt (BCIP), Tween 20,

Triton X-100, tetramethylethylenediamine (TEMED) (US Biochemicals, USA).

9. Protein gel electrophoresis apparatus (Bio-Rad, USA).
10. Acrylamide, ammonium persulfate (APS), sodium dodecyl sulfate (SDS), glycerol, glycine, isopropyl- β -D-1-thiogalactoside (IPTG), sucrose (Sigma-Aldrich).
11. Western blot apparatus (Bio-Rad).
12. PVDF membrane (Millipore, USA). Filter papers of Grade 2 and 3 (Whatman, GE Health Care, USA). U-tube concentrator (Novagen), dialysis tubes (Novagen, EMD Millipore, USA).
13. Ultracentrifuge and tubes (Optima L-100K, Beckman Coulter, USA).

2.5 Confirming VLP

1. Transmission electron microscope (Jeol, Tokyo, Japan).
2. Uranyl acetate (USB).

3 Methods

3.1 Amplification of HBc

Primers are synthesized based on the sequence (Subheading 2). HBc gene containing vector is used as template.

1. Set up the PCR reaction as shown in Table 1 and run as per the conditions listed.
2. Analyze the product on Etbr-agarose gel (0.8 %) (*see Note 1*).
3. Using UV transilluminator carefully slice out the product (*see Note 2*).
4. Weigh the slice, add appropriate volume of capture buffer and dissolve the gel (*see Note 3*).
5. Add the dissolved gel mixture to the GFX gel binding column and wash with washing buffer (as described by the manufacturer) (*see Note 4*).
6. Elute the products into sterile water (~50 μ l) (*see Note 5*).
7. Keep the products in -20°C until use.

3.2 Modification of HBc

The amplified HBc from Subheading 3.1, **step 1** can be used for the modification (*see Note 6*).

1. *PCR 1* (*see Note 7*).
 - (a) Follow the PCR conditions as shown in Tables 1 and 2.
 - (b) Run the products on 0.8 % agarose gel and slice out specific product from gel and elute into nuclease-free water using GFX column.
 - (c) Keep the products in -20°C until use.

Table 1
PCR conditions used for gene amplifications

Sl. No.	Primers	Initial denaturation	Denaturation Annealing Extension			Final extension
			(35 cycles)			
1	CEFP2 and CEHsR	95 °C, 4 min	95 °C, 45 s	55.2 °C, 30 s	72 °C, 1 min	72 °C, 7 min
2	CEFP2 and CMPRP	95 °C, 4 min	95 °C, 45 s	59.2 °C, 30 s	72 °C, 1 min	72 °C, 7 min
3	CMPFP and CEHsR	95 °C, 4 min	95 °C, 45 s	57.8 °C, 30 s	72 °C, 1 min	72 °C, 7 min
4	PCR 1 and PCR 2 products	95 °C, 4 min	95 °C, 45 s	57.8 °C, 30 s	72 °C, 1 min	72 °C, 7 min

Table 2
PCR reaction mixture compositions

Sl. No.	Component	Vol (for 50 µl)
1	Water	39.5
2	10× reaction buffer	5
3	dNTP mix (2.5 mM stock)	0.2
4	Primer 1 (10 µM stock)	2.5
5	Primer 2 (10 µM stock)	2.5
6	Taq DNA polymerase	0.3

2. *PCR 2* (*see Note 8*).

- Follow the PCR conditions as shown in Tables 1 and 2.
- Determine the products size on 0.8 % agarose gel and elute the specific band into nuclease-free water using GFX column.
- Keep the products in –20 °C until use.

3. *PCR 3* (*see Note 9*).

- Keep the reaction setup for the PCR as shown in Tables 1 and 2.
- Visualize the size of the product on 0.8 % agarose gel and select the specific band, cut out and elute into nuclease-free water using GFX column.
- Keep the products in –20 °C until use.

4. *PCR 4* (*see Note 10*).

- Set up the PCR as per conditions shown in Tables 1 and 2.

Table 3
Restriction enzyme digestion reaction composition

Sl. No.	Component	Vol (for 20 μ l)
1	Water	13.8
2	Buffer (10 \times)	2
3	BSA	0.2
4	Plasmid (or PCR product)	2
5	Enzyme 1	1
6	Enzyme 2	1

(b) Analyze the product size in 0.8 % agarose gel.

(c) Gel-elute the specific band into nuclease-free water, keep the products in -20°C until use.

3.3 Clone Modified-HBc Gene into pET 32 Plasmid

1. Keep restriction digestion reaction for pET32a and modified HBc separately, with the enzymes *NdeI* and *XhoI*, as shown in the reaction (*see Note 11*) (Table 3).
2. Run the products in agarose gel and slice out the digested vector (pET32) and inserts (digested HBc-modified).
3. Elute the products in sterile water separately as described before.
4. Keep eluted products for ligation (as shown in Table 4) at 4°C , overnight (*see Note 12*).
5. Spin down the ligation mixture (*see Note 13*).
6. Add full mixture into JM109 competent cells.
7. General transformation procedure was followed (*see Note 14*).
8. Transformed bacterial colonies were selected using ampicillin containing plates.
9. Select colonies and inoculate to 4 ml LB broth containing ampicillin (60–100 $\mu\text{g}/\text{ml}$) and incubate the culture tubes at

Table 4
Ligation reaction composition

Sl. No.	Component	Vol (for 10 μ l)
1	Water	1
2	Ligation buffer (10 \times)	1
3	Insert DNA	5
4	Vector DNA	2
5	DNA ligase	1

37 °C in a shaker incubator at 160 rpm till OD₆₀₀ reaches ~1 (*see Note 15*).

10. Isolate the plasmids (follow instructions of the plasmid isolation kit) and analyze the plasmid on agarose gel after restriction digestion (*see Note 16*).
11. Colony containing inserts of proper size can be grown in large scale to increase the plasmid quantity (*see Note 17*).
12. From the selected cultures isolate plasmid in 1× TE buffer and store in -20 °C.
13. Store the selected cultures that contain the plasmid as a main stock at -80 °C.

3.4 Amplification of CFP 10 Gene from Mtb

Mycobacterium tuberculosis H37Rv cultured on Lowenstein-Jensen medium (LJ medium) can be used for DNA isolation. Standard procedures are available to isolate genomic DNA of Mtb; in our laboratory we follow the CTAB method [23]. In Brief, suspend the bacterial pellets in TE buffer containing proteinase K and SDS. Precipitate the protein contaminants from the solution using CTAB (65 °C for 1 h) solution. Subsequently DNA can be purified by extracting with Chloroform: Isoamyl alcohol (24:1). Precipitate DNA using 2.5 volumes of ice-cold absolute ethanol and one-tenth volume of Sodium acetate (3 M, pH 5.2). Wash the spooled DNA with 70 % ethanol, air dry, dissolve and store in TE buffer at -20 °C till use (*see Note 18*).

1. Amplify the CFP-10 gene from Mtb genome using the primers Mcfp10F and Mcfp10R as per the conditions shown in Tables 1 and 2 (*see Note 19*).
2. Determine the products size by running on 0.8 % agarose gel.
3. Purify the gel bands using GFX column and elute into nuclease-free water.
4. Keep the products at -20 °C until use.

3.5 Cloning of CFP 10 Genes into Modified HBc MIR

1. Digest both pET containing modified HBc/MIR and CFP 10 amplicon using restriction enzymes *EcoRI* and *HindIII* (*see Note 20*).
2. The restriction enzyme reactions are as shown in Table 4.
3. Elute the digested products into nuclease-free water using GFX column.
4. Keep the vector and insert for ligation reaction as stated in Table 4.

3.6 Transforming Ligated Plasmid (HBc-CFP10 in pET32) into E. coli JM109

1. Use the ligated product from the above procedure to transform JM109 as shown in previous procedure (*see Note 21*).
2. From the selected cultures isolate plasmid in 1× TE buffer and store in -20 °C.

3.7 Transformation into *E. coli* BL21 (DE3) and Protein Expression (See Note 22)

1. General transformation procedure can be followed here.
2. Select the transformed bacterial colonies using ampicillin containing plates.
3. Select colonies and inoculate first into 4 ml LB containing ampicillin.
4. On reaching OD₆₀₀ value ~1, inoculate the culture to large volumes (here used 200 ml, in Ultra Yield Flasks).
5. Keep the flasks at 37 °C, with shaking at 300 rpm until the culture reaches OD₆₀₀ value of 0.6–1.
6. On reaching the specific OD, induce protein expression by adding IPTG (0.5 mM).
7. After induction keep the flask in shaking incubator 28 °C, 300 rpm for nearly 6 h.
8. Pellet the cells (here use 50 ml conical bottom Falcon tubes), and keep the pellets at –80 °C until the next procedure.

3.8 Protein Purification (See Note 23)

1. Resuspended the pellets in lysis buffer I (100 mM NaCl, 50 mM Tris–HCl (pH 8), 0.2 % Triton X-100 and 10 µg/ml DNase) (*see Note 24*).
2. Lyse the cells on ice by ten cycles of sonication with 1 min intervals to avoid heating of the material (*see Note 25*).
3. Remove the *E. coli* cell debris by centrifugation at 10,000 × *g* at 4 °C for 20 min, and collect the supernatant.
4. Load the supernatant on 20 % sucrose cushion at 25,000 rpm (106750 × *g*) and pellet the particles (*see Note 26*).
5. Resuspend the pelleted material in dissociation buffer (6 M urea, 10 mM imidazole, 50 mM Tris–HCl (pH 8.0), and 50 mM NaCl), and incubate at room temperature for 15 min. All subsequent steps can be performed at room temperature.
6. Pre-equilibrate the Ni-Silica resin column in dissociation buffer (*see Note 27*).
7. Add the particle suspension to the pre-equilibrated resin and allow to bind for nearly 30 min.
8. Wash the resin by decreasing concentration of urea by washing with washing buffer (20 mM imidazole, 50 mM Tris–HCl (pH 8.0), and 50 mM NaCl) containing 5, 4, 3, 2, 1 and 0.5 and 0 M urea, followed by washing buffer containing 300 mM NaCl (*see Note 28*).
9. Add twice the gel bed volume of elution buffer (250 mM imidazole, 50 mM Tris–HCl (pH 8.0), and 300 mM NaCl), after a 30 min incubation, elute the proteins by gravity flow.
10. Dialyse the eluted fractions using D-Tube Dialyzer (observing manufacturers' protocol) (*see Note 29*).

11. The sample can be concentrate by passing it through 3 kDa cutoff membrane (Amicon Ultra, Millipore) (*see Note 30*).
12. The concentrated product layer on the top of a sucrose density gradient (10–60 % discontinuous sucrose gradient) (*see Note 31*).
13. Proceed with ultracentrifugation at 40,000 rpm ($274355 \times g$), 25 °C for 2 h for 30 min on (swinging bucket rotor SW 41TI, Beckman Coulter).
14. After centrifugation samples collect as 500 µl aliquots each from the top layer (*see Note 32*).
15. Analyze the fractions on SDS-PAGE and confirm by Western blot (Fig. 3) (*see Note 33*).

3.9 Confirmations of Purified Proteins

Sucrose density gradient fractions from HBc and fusion proteins were analyzed on Transmission Electron Microscope at various magnifications.

1. Dilute the samples in 1× PBS.
2. Layer the samples on TEM-copper grid and the grids.
3. Keep the sample in a desiccator to remove moisture content (*see Note 34*).
4. Apply 2 % uranyl acetate solution on the layered sample.
5. Observe the images with TEM at different magnifications.

4 Notes

1. From the reaction product take 2 µl from tubes and check on agarose gel to confirm the size on Etbr-agarose gel (0.8 %) with 100 bp DNA ladder as a marker. Care should be taken as Etbr is carcinogenic.
2. High exposure of UV on gel may affect the downstream process, so minimize the exposure time. Other methods which stain DNA without UV exposure also can be used in this step.
3. The gel should solubilize completely otherwise it may interfere with the DNA recovery.
4. After the column wash, allow ethanol content to dry completely by keeping the column for few min at room temperature.
5. Elute the product in sterile water; chelating agents containing buffers may interfere in downstream process such as restriction enzyme digestion and ligation.
6. The HBc gene encoding amino acids necessary for the VLP formation is required (149aa), the remaining part of the sequences are DNA binding region for the native virus.

7. Here the reverse primer (CMPRP) incorporates modified nucleotides which span the area intended to amplified (MIR region) is used.
8. Here the forward primer (CMPFP) has incorporated modified nucleotides.
9. The products of the above reactions (PCR 1 and PCR 2) are allowed to extend the modified regions in this step.
10. The product of PCR 3 was used as the template in this step, the primers (CEFP2 and CEHsR) used are the same as that for amplifying HBc gene.
11. *NdeI* and *XhoI* digestion removes most of the Multiple Cloning Site of the vector, while designing His tag on the primer itself results in proper protein expression with the desired tag at one end.
12. The ligation for overnight has shown to be more successful than other temperatures and conditions.
13. In this step, the whole ligation reaction mixture can be directly used for transformation experiment, but verify the clones after selection.
14. General transformation method used [24].
15. Glycerol stocks can be prepared in this step.
16. The insert can be verified by double digestion using the same enzymes used for cloning the insert. The insert can be confirmed by setting up a new PCR reaction with primers specific for the insert.
17. The procedures following this step require more concentration of plasmids, and so it is better to keep plasmid in required quantity by transforming and isolating from JM109 bacterial cells.
18. CTAB method is one of the best methods to recover good quality DNA from Mtb.
19. Primers for inserting CFP-10 gene into the modified HBc gene, Mcfp10F and Mcfp10R were designed to amplify CFP-10 gene from Mtb and then clone into the modified region of the HBc gene in pET vector.
20. The pET 32 containing modified HBc and the product from the procedure in Subheading 3.2 can be used here.
21. Use the same method used for the previous ligation reaction.
22. BL21 should be always used fresh for transformation, because variations in expression have been observed if frozen or old transformed colonies are used repeatedly.
23. Purification of VLPs were done as per earlier reports [25, 26] with minor modifications.

24. If the samples are in frozen condition, allow the bacterial pellet to thaw and then proceed for sonication.
25. Avoid frothing of cell suspension solution during sonication.
26. This step helps to concentrate the particles for further purification steps and help to avoid most of the *E. coli* proteins.
27. Urea may be difficult to handle at 6 M concentrations; the procedure can be done at room temperature.
28. The step should be done slowly and carefully as the stepwise reduction in urea concentration is critical.
29. Dialysing with D-Tube Dialyzer is simple and less time consuming. This step avoids higher salt concentrations if present.
30. If the sample from above step seems to be diluted, the concentration can be increased by the Amicon concentration method.
31. Carefully layer on the top of gradient.
32. This step helps to clearly analyze the gradient fractions for the presence of VLPs.
33. Antibodies against HBc or to the inserted Mtb antigen or anti-his antigen can all be used here, to confirm the presence of fusion proteins expressed.
34. Higher moisture content may interfere with TEM imaging.

Acknowledgements

We thank Laiza Paul K for assistance during Mtb culture. DD acknowledges University Grants Commission for a research fellowship.

References

1. WHO (2014) Global tuberculosis report 2014. World Health Organization, Geneva
2. Cole ST, Brosch R, Parkhill J, Garnier T et al (1998) Deciphering the biology of Mycobacterium tuberculosis from the complete genome sequence. *Nature* 393:537–544
3. Raja A (2004) Immunology of tuberculosis. *Indian J Med Res* 120:213–232
4. Parkash O (2014) Vaccine against tuberculosis: a view. *J Med Microbiol* 63(Pt 6):777–779
5. Andersen P, Andersen AB, Sorensen AL, Nagai S (1995) Recall of long-lived immunity to Mycobacterium tuberculosis infection in mice. *J Immunol* 154:3359–3372
6. Skjot RL, Oettinger T, Rosenkrands I, Ravn P, Brock I, Jacobsen S, Andersen P (2000) Comparative evaluation of low-molecular-mass proteins from Mycobacterium tuberculosis identifies members of the ESAT-6 family as immunodominant T-cell antigens. *Infect Immun* 68:214–220
7. Weinrich Olsen A, van Pinxteren LA, Meng Okkels L, Birk Rasmussen P, Andersen P (2001) Protection of mice with a tuberculosis subunit vaccine based on a fusion protein of antigen 85b and esat-6. *Infect Immun* 69:2773–2778
8. Olsen AW, Williams A, Okkels LM, Hatch G, Andersen P (2004) Protective effect of a tuberculosis subunit vaccine based on a fusion of antigen 85B and ESAT-6 in the aerosol guinea pig model. *Infect Immun* 72: 6148–6150
9. Skeiky YA, Alderson MR, Ovendale PJ, Guderian JA et al (2004) Differential immune responses and protective efficacy induced by components of a tuberculosis polyprotein vaccine, Mtb72F, delivered as naked DNA or recombinant protein. *J Immunol* 172:7618–7628

10. Brandt L, Skeiky YA, Alderson MR, Lobet Y et al (2004) The protective effect of the Mycobacterium bovis BCG vaccine is increased by coadministration with the Mycobacterium tuberculosis 72-kilodalton fusion polyprotein Mtb72F in M. tuberculosis-infected guinea pigs. *Infect Immun* 72:6622–6632
11. Olsen AW, Hansen PR, Holm A, Andersen P (2000) Efficient protection against Mycobacterium tuberculosis by vaccination with a single subdominant epitope from the ESAT-6 antigen. *Eur J Immunol* 30:1724–1732
12. Aguilar JC, Rodriguez EG (2007) Vaccine adjuvants revisited. *Vaccine* 25:3752–3762
13. Hubbell JA, Thomas SN, Swartz MA (2009) Materials engineering for immunomodulation. *Nature* 462:449–460
14. Dhanasooraj D, Kumar RA, Mundayoor S (2013) Vaccine delivery system for tuberculosis based on nano-sized hepatitis B virus core protein particles. *Int J Nanomedicine* 8:835–843
15. Grgacic EV, Anderson DA (2006) Virus-like particles: passport to immune recognition. *Methods* 40:60–65
16. Bachmann MF, Jennings GT (2010) Vaccine delivery: a matter of size, geometry, kinetics and molecular patterns. *Nat Rev Immunol* 10:787–796
17. Fifis T, Gamvrellis A, Crimeen-Irwin B, Pietersz GA et al (2004) Size-dependent immunogenicity: therapeutic and protective properties of nano-vaccines against tumors. *J Immunol* 173:3148–3154
18. Arend SM, Geluk A, van Meijgaarden KE, van Dissel JT et al (2000) Antigenic equivalence of human T-cell responses to Mycobacterium tuberculosis-specific RD1-encoded protein antigens ESAT-6 and culture filtrate protein 10 and to mixtures of synthetic peptides. *Infect Immun* 68:3314–3321
19. Qiao D, Li L, Guo J, Lao S, Zhang X, Zhang J, Wu C (2011) Mycobacterium tuberculosis culture filtrate protein 10-specific effector/memory CD4(+) and CD8(+) T cells in tubercular pleural fluid, with biased usage of T cell receptor Vbeta chains. *Infect Immun* 79:3358–3365
20. Lalitha S (2000) Primer premier 5. *Biotech Softw Inter Rep* 1:270–272
21. Boratyn GM, Camacho C, Cooper PS, Coulouris G et al (2013) BLAST: a more efficient report with usability improvements. *Nucleic Acids Res* 41(Web Server issue):W29–W33
22. Subramaniam S (1998) The Biology Workbench—a seamless database and analysis environment for the biologist. *Proteins* 32:1–2
23. De Almeida IN, Da Silva CW, Rossetti ML, Costa ER, De Miranda SS (2013) Evaluation of six different DNA extraction methods for detection of Mycobacterium tuberculosis by means of PCR-IS6110: preliminary study. *BMC Res Notes* 6:561
24. Sambrook J, Fritsch E, Maniatis T (1989) *Molecular cloning: a laboratory manual*, 2nd edn. Cold Spring Harbor Press, Cold Spring Harbor, NY
25. Wizemann H, von Brunn A (1999) Purification of E. coli-expressed HIS-tagged hepatitis B core antigen by Ni²⁺-chelate affinity chromatography. *J Virol Methods* 77(2):189–197
26. Vogel M, Diez M, Eisfeld J, Nassal M (2005) In vitro assembly of mosaic hepatitis B virus capsid-like particles (CLPs): rescue into CLPs of assembly-deficient core protein fusions and FRET-suited CLPs. *FEBS Lett* 579:5211–5216

Formulation Studies During Preclinical Development of Influenza Hemagglutinin and Virus-Like Particle Vaccine Candidates

Newton Wahome, John M. Hickey, David B. Volkin,
and C. Russell Middaugh

1 Introduction

1.1 *Virus-Like Particles for Vaccine Use*

Virus-like particles (VLPs) are oligomeric associations of viral protein(s) that rely on the principles of self-assembly to create “bio-containers” with core-shell morphologies [1, 2]. VLPs present viral protein antigens on their surface in an array-like manner, similar to the assembly of virus capsids in nature [3]. Due to their repetitive antigen array display system, VLPs have been implicated in increased immune responses when used as vaccine platforms compared to monomeric versions of the same antigen protein [4, 5]. VLPs do not contain a genome, eliminating the possibility of infection through the replication of pathogenic viral components. Modern VLP production technology has taken advantage of advances in molecular cloning and expression systems, leading to a new class of safe and effective commercial and candidate vaccines [6, 7]. The production of VLPs as vaccine candidates brings challenges common to the manufacture of biological drugs, including requirements of formulation development to maintain long-term stability and efficacy in a pharmaceutical relevant form that can be conveniently administered to patients [7–9].

Maintaining the pharmaceutical stability of the oligomeric components in VLPs (e.g., proteins, lipid bilayers, etc.) is a key challenge in formulation development, since the particles may be prone to physicochemical degradation [10, 11]. VLP degradation can occur at any point during the manufacturing process ranging from expression, purification, and stresses during storage (e.g., photo-exposure, freezing, lyophilization, elevated temperatures, shipping, etc.), which can lead to a loss of vaccine potency and efficacy [12, 13]. Thus VLP formulation development aims to not

only elucidate the causes and mechanisms of vaccine instability, but to also increase storage stability by screening a library of potential excipients with various physicochemical and biological techniques to assess their ability to decrease the rate and extent of VLP degradation [7, 14]. Early stage formulation development of vaccine candidates mitigates against expenses and/or production delays, due to VLP instability, that can occur during a vaccine candidate's clinical development [13].

1.2 Physical and Chemical Degradation

VLP vaccines need to maintain immunogenicity and potency during long-term storage and subsequent distribution to clinical and/or vaccination sites. Therefore, formulation development strategies should be employed to ensure patients receive stable and efficacious vaccines [13]. One key aspect of successful formulation development of a vaccine is determining the chemical and physical degradation pathways that result in the loss of structural integrity and affects the potency and clinical efficacy [14]. Chemical degradation of protein antigens primarily occurs through reactions of the amino acid side chains such as oxidation and deamidation, leading to the formation of new chemical variants (e.g., deamidation of asparagine residues into a mixture of aspartate and isoaspartate) [12]. Physical degradation of VLPs can result from changes to secondary and tertiary structure of the component protein molecules, aggregation of the VLPs due to colloidal instability, partial or complete unfolding of the VLPs, or even phase transitions due to various stresses [15, 16]. Chemical and physical degradation pathways are often interconnected, with one degradation phenomena usually affecting another (for example, oxidation of a protein leading to its aggregation) [17, 18]. Degradation pathways can lead to a change in the structure of the proteins within a VLP, reducing potency by altering the physical presentation of immunogenic epitopes, or exposing hydrophobic patches that might accelerate the formation of VLP aggregates [18].

Structural degradation of VLPs can be induced by a variety of environmental stresses including thermal fluctuations, agitation, freeze–thaw cycling, presence of contaminants, or even oscillations in pressure during processes such as lyophilization. Thermal exposures can lead to the partial or complete unfolding of the VLP protein subunits, exposing hydrophobic residues to solvent, and accelerating chemical degradation events such as oxidation and deamidation [17, 19]. Agitation stresses can stem from the mechanical components required for process development, such as pumps and filtration units used during manufacture and processing [18, 20]. Contaminants, such as co-expressed proteins or nucleic acid remnants from the host cells, trace chemicals from the purification process, lower-purity grade formulation excipients, or extrables leaching from materials used during manufacture and storage (e.g., primary containers), can generate nucleation points

that accelerate the rate of aggregation [21]. Although frozen storage and/or lyophilization can be used to improve long-term storage of proteins, such processes in themselves can lead to destabilization. For example, cycling through freeze–thaw regimes can lead to aggregation events, induced by phenomena such as adsorption to the container surface or by drastic changes in pH due to buffer crystallization [15, 22]. Lyophilization of VLPs can induce freeze–thaw stresses and an increase in the local protein concentration due to the sublimation of water, leading to the formation of precipitates [23, 24]. Therefore, design of a stable vaccine formulation is a necessary early stage development activity for the mitigation of vaccine degradation events by using strategies such as regulating solution pH and ionic strength, enhancing cryo- and lyo-protection by addition of pharmaceutical excipients, and reducing self-association solution conditions that might lead to VLP aggregation [25].

1.3 Excipients

In VLP based vaccines, excipients can help to stabilize the macromolecular components of the immunogen and the particle itself by reducing self-association and aggregation prone interactions, maintaining pH and tonicity, and regulating conformational stability in solution and/or during adsorption to adjuvants such as aluminum salts [26]. Excipients can range from small molecular weight buffer molecules to larger, more complex polymers, and are usually selected, as a starting point, from a regulatory list of generally regarded as safe (GRAS) compounds [27, 28].

The pH of a vaccine formulation has an effect on the chemical and physical stability of VLPs. Therefore, buffering components are added to maintain the pH of the solution [10]. For example, deamidation is usually controlled by modulation of pH, with both extremes of pH catalyzing deamidation by different mechanisms [12, 29]. Thus, more slightly acidic to neutral conditions of pH (range of pH 5–7) are usually advantageous. Based on the pH range of interest, buffering excipients can include molecules such as acetate, borate, citrate, histidine, phosphate, succinate, and tris(hydroxymethyl)aminomethane [25]. The tonicity and osmolarity of the formulation governs not only protein stability, but potentially local site reactions as well as the pain perceived by patients during injection [30]. Regulating the concentration of excipients and salts can also help in modulating tonicity and minimize clinical outcomes due to injection site reactions. Inorganic salts, such as sodium chloride (NaCl) and potassium chloride (KCl), can be used to adjust the osmolality and ionic strength of the formulation [31]. Other commonly used tonicifying agents include amino acids and sugars.

Amino acids can aid in vaccine formulation development by increasing protein solubility, reducing propensity for aggregation, acting as antioxidants, regulating tonicity, and substituting as bulk-

ing agents during lyophilization. Mechanisms of their action can include direct binding to protein interfaces or preferential hydration [32–34]. Commonly used amino acids for these purposes include aspartic acid and glutamic acid (sodium salt), arginine, histidine, proline, glycine, methionine, and lysine [33, 35–38].

Sugars and polyols are thought to employ preferential hydration as a major mechanism to stabilize proteins by inducing compaction and rigidification of the overall folded, tertiary structure of proteins [39, 40]. Carbohydrate based excipients include sucrose, trehalose, and lactose, with stabilizing polyols including molecules such as glycerol, mannitol, and sorbitol [32, 39]. Oxidation reactions can be catalyzed by contaminant metals often found in sugar excipients, potentially causing oxidation reactions with a variety of amino acid residues (e.g., Met, His, Trp) or free thiol groups (cysteine residues) found on the protein surface [38]. Metal ion chelating agents can be added to slow the rate of these oxidation reactions [41], including ethylenediaminetetraacetic acid (EDTA) and citric acid [42].

The aggregation of VLPs can result from agitation stresses, adsorption to container surfaces, or self-association due to formation of solvent-exposed hydrophobic regions [43]. Surfactant molecules are surface active agents that can “outcompete” protein molecules for interfaces, and thus reduce VLP aggregation by preventing the adsorption of proteins to surfaces/interfaces, such as container surfaces, air bubble interfaces, or hydrophobic patches on proteins [44]. Surfactants can be nonionic, cationic, or anionic, including agents such as Brij® 35, benzylalkonium chloride, docosate sodium, polysorbate 20, polysorbate 80, Triton™ X-100, and Pluronic® F-68 [45, 46]. As an example, Triton™ X-100 is used in split-virion, inactivated influenza vaccines [47, 48]. Proteins can also be used to mitigate aggregation by interacting with hydrophobic antigen surfaces [49]. Examples of proteins used as stabilizing excipients for this purpose in vaccines include human serum albumin and hydrolyzed gelatin [33].

1.4 Case Studies

Here, we present experimental methods for advancing the preclinical formulation development of a specific category of vaccine candidates: influenza VLPs and influenza particle-like vaccine candidates. These three case studies serve as an example of the various aspects of influenza VLP and particle vaccine formulation development. Although each VLP antigen is different with its own physicochemical and biological stability profiles, the considerations described below can be utilized as a general guide for some of the types of issues that need to be addressed during VLP vaccine formulation development. Even for influenza VLPs, the specific HA protein antigen can vary each year, which in turn can potentially affect the physicochemical behavior of the VLPs. The first study monitors the physical degradation of influenza H1N1 VLPs in the presence of differing pH and thermal stability [50]. Excipient

screening is performed to inhibit aggregation of the VLPs. The second study looks at the contribution of chemical degradation to the decreased potency of hemagglutinin (HA), which is the main antigen displayed in most influenza VLP strategies [51]. Recombinant HA (rHA) has been shown to self-assemble into rosettes that are approximately 40 nm in size, using self-assembly principles that are similar to the formation of quasi-spherical VLPs [52]. In this study, the chemical degradation pathway is determined to be based on the formation of nonnative disulfide bridge cross-linking (oxidation) in a recombinant HA (rHA) H3 antigen [51]. The third case study looks at the effect of freezing and freeze-drying on the conformational stability of the HA component of an H3N2-inactivated influenza vaccine [53].

2 Materials

2.1 Reagents

1. Influenza H1N1 virus-like particles (H1N1-VLPs), (LigoCyte Vaccines (now Takeda), Boseman, MT, USA). *See* ref. 50 for details.
2. Recombinant hemagglutinin (rHA) H3 influenza vaccine (A/Victoria/361/2011), (Protein Sciences Corporation, Groton, CT USA). *See* ref. 51 for details.
3. Inactivated influenza vaccine containing hemagglutinin (HA) (from strain A/Panama H3N2), (Solvay Pharmaceuticals, Weesp, The Netherlands). *See* ref. 53 for details.
4. 8-anilino-1-naphthalene sulfonate (ANS), (Molecular Probes, Eugene, OR, USA).
5. 6-Dodecanoyl-2-dimethylaminonaphthalene (laurdan), (Molecular Probes, Eugene, OR, USA).
6. Measure-iT Thiol assay kit (Invitrogen/Life Technologies, Grand Island, NY USA).
7. Most of the excipients in Table 1 were purchased from Sigma-Aldrich (St. Louis, MO, USA). Guanidine HCl, calcium chloride dihydrate, dextrose, d-mannitol, citric acid, and sodium phosphate dibasic were from FisherChemical (Fair Lawn, NJ, USA). Type A porcine gelatin was purchased from Dynagel (Calumet City, IL, USA) and d-sucrose and d-trehalose from Ferro Pfanstiehl Laboratories, Inc. (Waukegan, IL, USA) [50].
8. 2× laemmli buffer (Bio-Rad, Hercules, CA, USA).
9. 3–8 % Tris-Acetate gel (Invitrogen, Grand Island, NY, USA).

2.2 Instruments

1. Circular dichroism Jasco J-815 Spectrophotometer (Great Dunmow, UK).
2. Photon Technology International (PTI) spectrofluorometer (Lawrenceville, NJ, USA) equipped with a turreted four-position Peltier-controlled cell holder and a xenon lamp.

Table 1
Extent of aggregation of influenza virus-like particles in the presence of various potential stabilizers (grouped by class)

Excision	Concentration (Molarity or % w/v)	Inhibition ^a (%)
Ascorbic acid	0.15 M	-338.1 ^b
Aspartic acid	0.075 M	-13.5 ^b
Lactic acid	0.15 M	21.8
Malic acid	0.15 M	16.2
Arginine	0.3 M	70.0
Diethanolamine	0.3 M	67.4
Guanidine HCl	0.3 M	30.1
Histidine	0.3 M	30.2
Lysine	0.3 M	70.1
Proline	0.3 M	21.7
Glycine	0.3 M	12.1
Brij 35	0.01%	67.7
Brij 35	0.05%	36.9
Brij 35	0.10%	60.0
Tween 20	0.01%	60.3
Tween 20	0.05%	98.5
Tween 20	0.10%	91.2
Tween 80	0.01%	57.9
Tween 80	0.05%	45.1
Tween 80	0.10%	52.6
Pluronic F-68	0.01%	3.4
Pluronic F-68	0.05%	65.4
Pluronic F-68	0.10%	43.1
Albumin (human)	1%	-55.2 ^b
Albumin (human)	2.5%	-1597.3 ^b
Albumin (human)	5%	-1778.7 ^b
Gelatin (porcine)	2.5%	11.7
Gelatin (porcine)	5%	-54.7 ^b
Lactose	10%	-20.6 ^b
Lactose	15%	60.5

(continued)

Table 1
(continued)

Excision	Concentration (Molarity or % w/v)	Inhibition ^a (%)
Lactose	20%	75.0
Trehalose	10%	-227.5 ^b
Trehalose	15%	-2.9 ^b
Trehalose	20%	84.2
Dextrose	10%	25.9
Dextrose	15%	58.0
Dextrose	20%	66.7
Sucrose	10%	-113.3 ^b
Sucrose	20%	28.4
Mannitol	10%	-19.5 ^b
Sorbitol	10%	-66.1 ^b
Sorbitol	15%	45.2
Sorbitol	20%	80.1
Glycerol	5%	23.4
Glycerol	10%	82.3
Glycerol	15%	41.8
Glycerol	20%	69.1
α -Cyclodextrin	2.5%	-91.2 ^b
2-OH propyl β -CD	5%	19.2
2-OH propyl β -CD	10%	249.2 ^c
2-OH propyl γ -CD	5%	27.4
2-OH propyl γ -CD	10%	12.1

Percent inhibition of aggregation of H1N1 VLPs by addition of GRAS excipients, calculated as $[1 - (\Delta OD_{350} \text{ sample} / \Delta OD_{350} \text{ control})] \times 100 \%$

CD cyclodextrin

^aRelative to the control sample at $t=15$ min or $t=30$ min. Inhibition calculated as $[1 - (OD_{350} \text{ sample} / OD_{350} \text{ control})] \times 100 \%$. The relative standard deviation in these calculated values was 10 % or less

^bA negative percentage inhibition value indicates that the excipient enhanced aggregation

^cThis percentage inhibition value is misleading. The sample precipitated during analysis, apparently lowering the optical density value

Adapted from Kissman et al. [50], with permission from Wiley Publishers

3. Lyostar II (FTS systems, SP Industries, Warminster, PA, USA) or similar freeze dryer from other manufacturers.
4. Modulated differential scanning calorimetry (Q1000 TA instruments, New Castle, DE, USA).
5. Brookhaven Instrument Corporation dynamic and static light scattering system (Holtsville, NY, USA).
6. Agilent 8453 spectrophotometer (Palo Alto, CA, USA).
7. Spectramax Plus 384 fluorescence microplate reader (Molecular Devices, Sunnyvale, CA, USA).
8. SDS-PAGE gel casting chambers, Mini-PROTEAN[®] Tetra cell electrophoresis chamber, PowerPac 300 power supply (SDS-PAGE instruments from Bio-RAD, Hercules, CA, USA).

3 Methods

3.1 Physical Degradation of Influenza H1N1 Virus-Like Particles

In the first case study, excipient stabilization of physical degradation pathways is tested on an influenza VLP comprised of two influenza antigens (hemagglutinin and neuraminidase surface proteins) and a lipid bilayer [50]. Physical degradation is measured by spectroscopic and light scattering techniques as a function of pH and thermal stress. The biophysical stability data are converted into an empirical phase diagram (EPD), to display and summarize the physical stability profile of the VLP and to ascertain the structural and colloidal stability apparent phase boundaries induced on the H1N1 VLPs by the pH and temperature stresses. A series of generally regarded as safe (GRAS) excipients are screened to mitigate physical degradation, with trehalose, sorbitol, and glycine being identified as effective stabilizers against physical degradation of the H1N1 VLPs (Table 1).

3.1.1 pH and Thermal Stability Monitored by Dynamic Light Scattering (DLS)

Dynamic light scattering (DLS) analyzes the Brownian motion of macromolecules by measuring the real-time fluctuation of light intensity caused by the diffusion of the particles in solution [54, 55]. The translational diffusion coefficient of a particle can be obtained from the time-dependent rate of light intensity fluctuation, known as the autocorrelation function (AF) [56]. The Stokes-Einstein equation derives the hydrodynamic radius of a particle from its translational diffusion [57]. Therefore, an effective diameter of the biological macromolecule can be calculated from DLS experiments, permitting the measurement of a VLP size distribution. Sample heterogeneity or polydispersity can also be obtained from the AF, providing an insight into the homogeneity of the protein populations under thermal stress [58]. The AF can be mathematically deconvoluted, to a limited extent, to yield up to three distinct particle sizes.

To conduct DLS experiments to monitor physical stability of the VLPs as a function of temperature and pH, the following steps are used:

1. Obtain clean, dust- and particle-free, quartz cuvettes and add a volume of 300 μL to 1 mL of protein (VLP) solution to each cuvette (done in triplicate). The volume is based on the path-length of the cuvette. The minimum protein concentration required for a good signal to noise ratio is normally 0.05–0.1 mg/mL. The signal to noise ratio of the VLP can be improved by maintaining signal intensity between 50 and 200 KCPS (thousands of counts per second).
2. For the Brookhaven DLS, the 532 nm incident light is generated by a 125 mW diode-pumped laser. Turn on the instrument and laser and wait for at least 15 min for the laser to warm up before data collection. Scattered light intensity is collected at 90° of the incident beam to measure the formation of aggregates. The light scattering signal intensity is normalized between 0 and 1, to permit for comparisons between experimental conditions. Another commonly used instrument for this purpose is the Wyatt DynaPro DLS plate reader (Wyatt Technology, Santa Barbara, CA, USA), for high-throughput and low sample volume analysis.
3. Effective particle diameters are extracted from the particles' translational diffusion coefficients using the autocorrelation function, generated by a digital autocorrelator (BI-9000AT). Cumulant analysis obtains effective particle diameters from the diffusion coefficients using the Stokes-Einstein equation (*see Note 1*). Sample polydispersity (or the second cumulant of the translational diffusion coefficients) can also be extracted from the correlation function. Polydispersity of less than $\sim 20\%$ represents the upper limit of an acceptable homogeneous population.
4. Thermal melts with DLS monitor changes in the effective VLP diameter, normalized light scattering intensity, and sample polydispersity induced by changes in solution pH and temperature (Fig. 1a). The temperature ramp experiment ranges from 10 to 85 $^\circ\text{C}$, with 5–10 measurements being taken at intervals of 2.5 $^\circ\text{C}$. A useful temperature ramp rate can be set to 1 $^\circ\text{C}/\text{min}$, with incubation times of 3 min.

3.1.2 pH and Thermal Stability Monitored by Circular Dichroism (CD)

CD detects conformational changes in biomolecules such as nucleic acids as well as proteins (e.g., protein secondary (far-UV CD) and tertiary (near-UV CD) structure) [59]. Some regions in biomolecules have an asymmetric or differential absorption of left-handed and right-handed circularly polarized light, permitting the detection of structural and conformational changes [60]. In the far-UV region, peptide bonds have a differential absorption of polarized light. This asymmetry in peptides permits the secondary structure

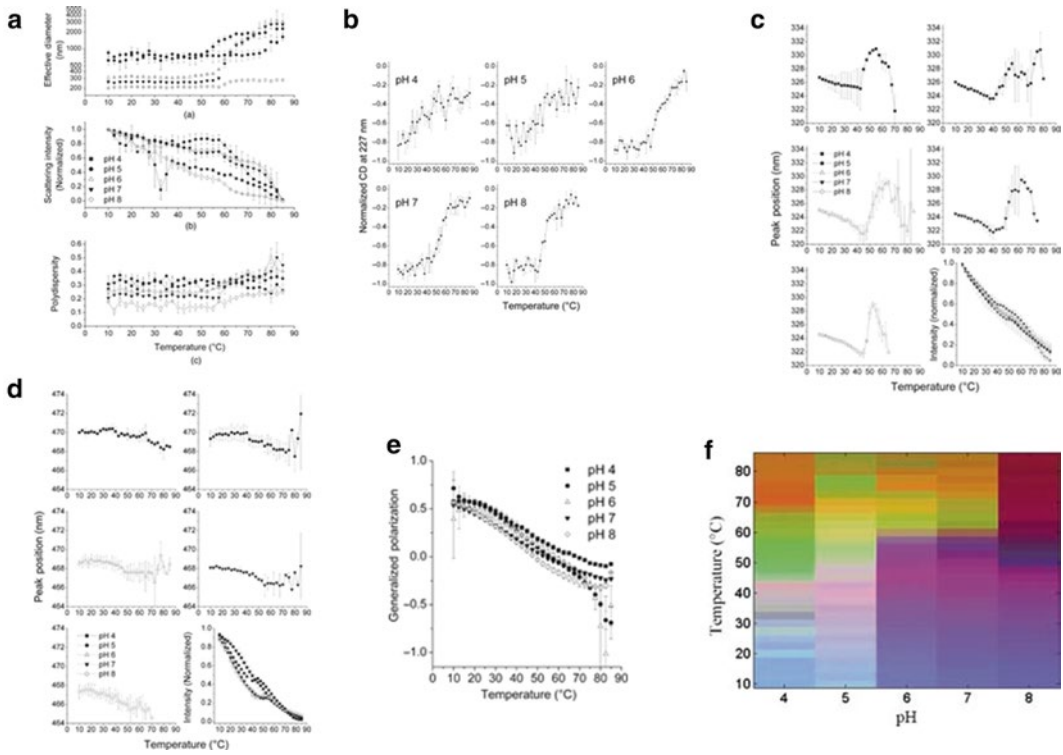

Fig. 1 Physical stability profile of influenza H1N1 VLPs monitored as a function of solution pH and thermal shifts. **(a)** Dynamic and static light scattering, **(b)** circular dichroism at 227 nm, **(c)** Peak position of intrinsic tryptophan fluorescence shifts, **(d)** Peak position shift in ANS extrinsic fluorescence, **(e)** Laurdan polarization, and **(f)** Empirical phase diagram summarizing results from the five different biophysical methods. Experiments were conducted in a citrate/phosphate buffer to permit the use of a wide pH range. Adapted from Kissman et al. [50], with permission from Wiley Publishers

assignment of biological macromolecules, providing information on α -helix, β -sheet, β -turn, and random coil regions [61]. Changes in protein tertiary structure can be measured in the near-UV region, based on the three-dimensional and orientation-dependent absorption properties of some amino acid residues such as tryptophan, tyrosine, phenylalanine, and cysteine [62]. In this protocol, CD is used to monitor the thermally induced changes in secondary structure of H1N1 VLP subunits under different temperature and pH conditions [59].

To monitor changes in protein secondary structure using far-UV CD, the following steps are used:

1. The lamp compartment is purged with nitrogen gas for 5 min. Depending on the CD instrument, lamp warm up times can range from 20 to 30 min (e.g., an air cooled 150 W Xenon arc lamp on the Jasco J-810 spectropolarimeter).

2. For far-UV CD experiments, prepare clean, dust-free 0.1 cm path length quartz cuvettes for measuring the CD spectra of the VLP sample (done in at least triplicate). The signal to noise ratio is dependent on the sample concentration, so at least 0.1–0.2 mg/mL of VLP is necessary, with a minimum sample volume of 200 μ L. Oversaturation of the CD detectors can occur at HT values greater than 700 V, will usually result in an increase in noise. Near-UV CD experiments will require higher protein concentrations (0.5–2 mg/mL) [62].
3. A typical temperature ramp experiment ranges from 10 to 87.5 $^{\circ}$ C, at a rate of 1 $^{\circ}$ C/min, with 3 min of incubation. The usual measurement range is 195 to 260 nm, with a bandwidth of 1 nm.
4. Depending on the sensitivity of the instrument and the quality of the data, smoothing algorithms may be necessary to get an accurate representation of peak position information.
5. Monitor the CD spectra for thermal or pH induced structural transitions at a wavelength of interest, for example, 227 nm for this study with H1N1 VLPs (Fig. 1b) (*see Note 2*).

3.1.3 pH and Thermal Stability Monitored by Intrinsic Tryptophan Fluorescence

Intrinsic fluorescence spectroscopy is used to monitor the tertiary structure integrity and stability of biological macromolecules [63]. Some aromatic amino acid residues in proteins, such as tryptophan, tyrosine, and phenylalanine, have fluorescent properties that can be used to detect conformational changes in proteins. For example, thermal unfolding can result in the shift of tryptophan residues from the more hydrophobic interior of the macromolecule to a more solvent exposed environment. The emission spectrum of a tryptophan residue in a structurally disruptive environment can be measured as a red shift in the wavelength signal maximum [19]. Thermal stability of a VLP can be measured by comparing the difference between the wavelength maxima of native protein versus temperature-perturbed protein. The protective or stabilizing capacity of formulations can also be tested, by measuring the onset or midpoint of thermal transitions (T_{onset} and T_m) in the presence of different pH and excipient conditions.

To monitor intrinsic tryptophan fluorescence of a protein antigen such as a VLP, the following procedures were used:

1. Obtain 1 cm quartz cuvettes and add 300 μ L of VLP solution to each cuvette (done in at least triplicate). Tryptophan residues can be excited at 295 nm, with an emission spectra being collected at 305 to 410 nm. The collection step size is 1 nm, integrating for 0.5–1 s. Intrinsic tryptophan fluorescence is measured with a PTI instrument (Birmingham, NJ, USA), equipped with a temperature-controlled 4-position sample cell holder.

2. Thermal melts to measure protein tertiary structure stability are performed at a temperature range of 10–87.5 °C, with the emission spectra being collected at 2.5 °C intervals. The sample is equilibrated for 3 min at each collection point, and if the instrument is capable, the sample heating rate is set to 1 °C/min.
3. The corresponding buffer spectrum is subtracted from each protein sample spectrum prior to data analysis [50]. Maximum peak intensity values and maximum wavelength peak position are monitored over the course of the thermal ramp (Fig. 1c). Peak position can be determined using a mean spectral center of mass method (MSM). See **Notes 3** and **4**.

3.1.4 pH and Thermal Stability Monitored by Extrinsic Fluorescence

In this protocol, extrinsic fluorescence experiments utilize hydrophobic dyes (e.g., SYPRO Orange, or in this case study, 8-anilino-1-naphthalene sulfonate (ANS)) to monitor thermal stability of influenza H1N1 VLPs under different solution pH conditions. Thermal perturbations may induce nonnative conformations, exposing hydrophobic patches or inducing aggregates that interact and/or bind to the dye inducing a change in the dye's fluorescence properties [64]. Although fluorescence spectrometers are routinely used for these measurements, reverse-transcription polymerase chain reaction (RT-PCR) instruments can be repurposed for these protein thermal stability measurements, permitting high-throughput and low sample volume analysis [19, 65, 66]. Another fluorescent molecular probe, laurdan, can be used to detect changes in the properties of lipid bilayers [67]. The structural integrity or permeability of VLPs with membranes can be monitored using this dye [50]. Laurdan contains a long acyl chain attached to a derivatized naphthalene moiety, permitting incorporation into lipid bilayers. An increase in membrane hydration can drive a transition in bilayer fluidity from a gel (less fluid) to a liquid crystalline (more fluid) phase [68].

To monitor pH and thermal stability of a protein antigen such as a VLP by extrinsic fluorescence, the following steps are used:

1. Fluorescence of the extrinsic probe is used to characterize shifts in VLP physical stability using a PTI instrument (Birmingham, NJ, USA), equipped with a temperature-controlled 4-position sample cell holder. One cm path length quartz cuvettes are used for emission spectrum collection, with minimum sample loading volumes of 300 µL of VLP formulations.
2. Molecular probe concentrations: (a) A 10 mM solution of 8-anilino-1-naphthalene sulfonate (ANS) in dimethyl sulfoxide (DMSO) is added to samples, to give a final ANS concentration of 80 µM, and (b) a 1.2 mM solution of laurdan in DMSO is added to samples, giving a final laurdan concentration of 9.6 µM.
3. Using an excitation wavelength of 385 nm, the fluorescence intensity of ANS is collected at 485 nm. Laurdan probes are excited at 340 nm, and monitored from approximately 440 to

around 490 nm (an increase in membrane water content shifts the emission of laurdan, and is measured by generalized polarization of fluorescence. *See Note 5*).

4. The intensity is recorded every 2.5 °C. The temperature ranges from 10 to 85 °C, with a temperature ramp rate of 1 °C/min and incubation time of 3 min.
5. Collect both buffer blanks, extrinsic probe blanks, and sample readings, with a minimum of 0.1 mg/mL VLP concentration. Subtract the extrinsic probe and buffer values from the fluorescence intensity of the sample.
6. At least triplicate readings are preferred, while duplicate readings can suffice for the initial screening of the effect of different excipients on VLP stability.
7. Monitor changes in intensity at a certain peak position of the extrinsic probe and normalize the fluorescence intensity between 0 and 1 to facilitate comparisons between data sets (Fig. 1d, e).

3.1.5 Empirical Phase Diagram (EPD)

The biophysical data sets from the previously described H1N1 VLP physical stability studies (Fig. 1a–e) can be combined into a single image, visually representing the overall structural changes in the VLPs. The empirical phase diagram (EPD) utilizes a mathematical technique (single value decomposition) that analyzes the biophysical data based on its predominant components [69]. The data are converted to a basis set representing a multidimensional vector space. The values of pH and temperature experimental data provide the n -dimensional vectors, normalized based on the number of techniques (n) that are calculated. An $n \times n$ density matrix with n eigenvectors is calculated from a summation of all the projected vectors. The n -dimensional vector set is converted into three dimensions by weighting the three eigenvectors with most significant contribution. The three most significant components are assigned different colors (red, green, and blue), indicative of the biophysical techniques' ability to measure the secondary, tertiary, or colloidal stability of the macromolecule. By this approach, a summary diagram can be produced, representing structural changes in the macromolecule over a pH and temperature space, as visualized in the form of a three-color diagram. An in depth review for the generation of empirical phase diagrams has been presented by Maddux et al. [70]. In Fig. 1f, the EPD shows approximately ten different structural regions over a pH and temperature space. The most dominant or native H1N1 VLP state is observed to be between pH 6–8, and 10–35 °C. The other regions reflect structurally altered proteins in the VLP at pH 4 and 5, aggregated proteins above 60 °C at pH 6 and 7, and a transition region between 35 and 55 °C. The transition temperature permits the development of an excipient screening assay, monitored in a thermal region of intermediate H1N1 VLP stability.

3.1.6 Excipient Screening

To measure the physical stability of influenza H1N1 VLPs in the presence of different additives and excipients, the following procedure can be used:

1. The optical density between 340 and 360 nm can be used to measure the colloidal stability properties of aggregating proteins. In this study, the turbidity of VLPs (measured as optical density at 350 nm, OD_{350}) is monitored over time at a single temperature to obtain the kinetics of aggregation.
2. Duplicate samples of VLPs in the presence or absence of various GRAS excipients are prepared at a protein concentration of 55 $\mu\text{g}/\text{mL}$ by diluting the concentrated protein with a 20 mM of citrate phosphate (CP) buffer and/or a concentrated excipient solution of the appropriate pH.
3. A temperature-controlled Agilent 8453 spectrophotometer (Palo Alto, CA, USA) measures OD_{350} at intervals of 30 s for 2 h at 60 °C. Before measurement, the spectrophotometer is blanked with a protein-free solution containing buffer and excipient. This represents the reference value ($t=0$), that is subtracted from later readings over the collection time (to calculate ΔOD_{350}).
4. The percentage inhibition of aggregation is calculated as $[1 - (\Delta OD_{350} \text{ sample} / \Delta OD_{350} \text{ control})] \times 100 \%$, using values corresponding to the time of maximum OD_{350} for the reference sample (either 15 or 30 min, *see* Table 1) [50].

3.2 Monitoring the Chemical Degradation of rHA H3 Rosettes

The second case study examines the chemical stability of a recombinant hemagglutinin (rHA) protein molecule. These highly purified rHA antigens are the basis of the recombinant-influenza vaccine Flublok[®], expressed in insect cell lines, and produced as multivalent batches to reflect the HA strain heterogeneity observed in annual influenza outbreaks [71, 72]. The recombinant rHA protein natively forms trimers, which in solution, self-associate into micelle-like particles of 40 nm, commonly referred to as rosettes [52]. In this case study, rHA H3 protein, in the form of rosettes in solution, was observed to lose potency ($\sim 50 \%$) after 1 month of storage at 4 °C, as measured by a single radial immunodiffusion (SRID) assay. This protocol characterizes this one type of rHA protein antigen to identify the mechanisms of SRID potency loss over time [51]. The study measures the chemical stability of the rHA protein within rosettes in different excipients and storage temperatures over an accelerated timeline. Potency loss over time in the SRID assay is correlated to the formation of nonnative, disulfide cross-linked rHA multimers and loss of free thiol content (Fig. 2).

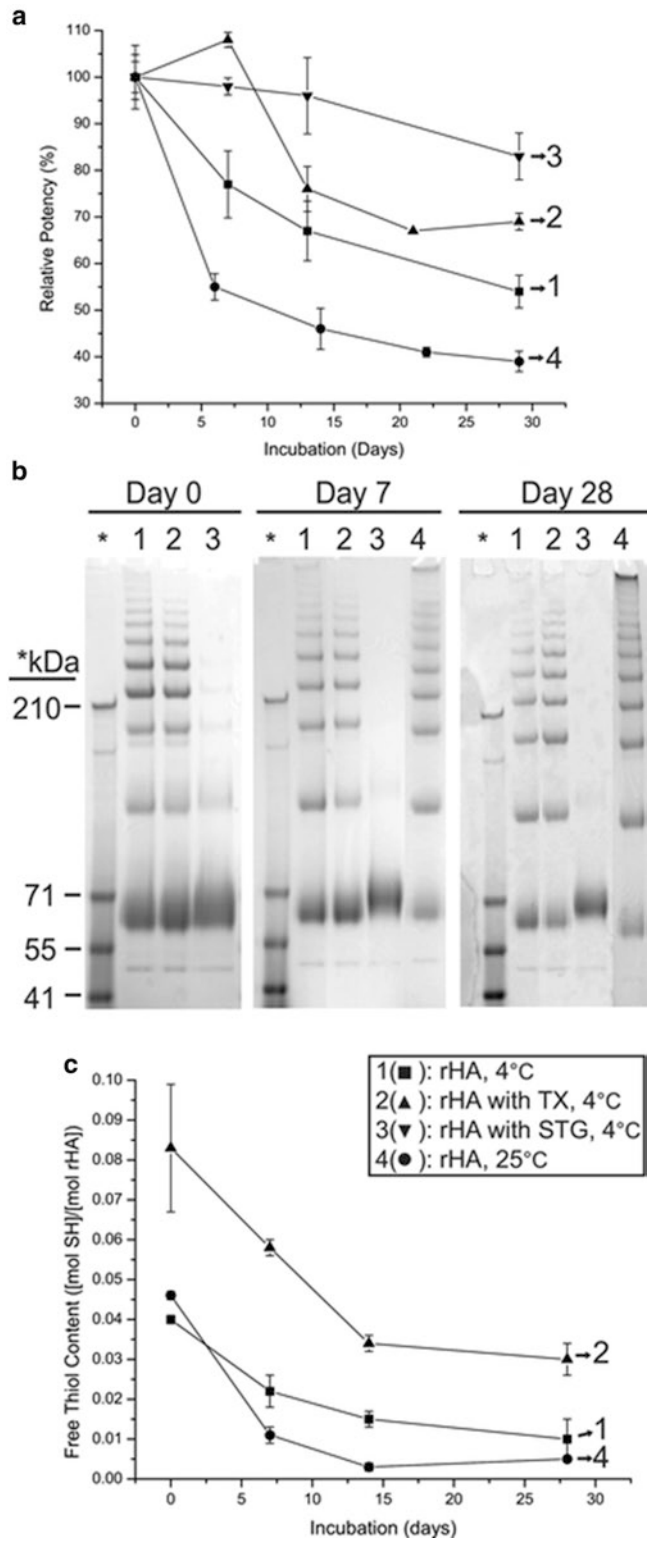

Fig. 2 Correlation of SRID potency loss in recombinant HA (rHA H3) samples over 28 days of storage vs. formation of nonnative disulfide bonds and loss of free thiols in the same rHA samples. **(a)** SRID assay potency of rHA H3, **(b)** SDS-PAGE analysis of multimer formation of rHA H3, and **(c)** Free thiol assay of rHA H3 samples. Adapted from Hickey et al. [51], with permission from Wiley Publishers

*3.2.1 Monitoring Potency
Loss by Single Radial
Immunodiffusion (SRID)
Assay*

The SRID assay is used to quantify the HA antigen content in an inactivated or recombinant influenza vaccine [73–75]. The method can be used to ascertain the potency of hemagglutinin antigen in a vaccine formulation. The assay measures HA potency based on the radial diffusion of HA in a polyclonal antibody gel matrix. The antigen and antibodies form a precipitant ring that expands until the amount of free HA antigen is depleted, reaching an equivalence in concentration between antigen and antibody [76, 77]. The FDA (Center for Biologic Evaluation and Research, CBER) provides both reference HA antigens and polyclonal antibodies each year for monitoring the activity of the HA components of the inactivated and recombinant influenza vaccines. In this study, rHA content was monitored by SRID assays over 28 days of storage under different storage conditions and with different excipients present [51]. The samples under reducing conditions, 0.2 % sodium thioglycolate (STG), maintain the highest potency during storage (Fig. 2a).

To perform the SRID assay [73, 75], the following steps are used:

1. In this assay, anti-HA polyclonal antibodies are placed in an agarose solution and plated on a thin gel layer perforated with 3–4 mm holes.
2. Samples are diluted with 1 % Zwittergent 3-14 to solubilize rHA rosettes and aid diffusion in the gel matrix.
3. The samples (rHA and reference HA antigen) are incubated in the gel, diffusing into the polyclonal antibody gel matrix to form precipitant rings. The precipitant rings are visualized with Coomassie blue stain.
4. HA vaccine potency is measured by comparing the precipitant ring diameters of rHA samples with reference HA on a standard curve. In this study [51], ≥ 5 independent measurements were taken over 28 days, with a standard deviation of $< 12.5\%$ (Fig. 2a).

*3.2.2 Monitoring rHA
Multimer Formation
by SDS-Polyacrylamide Gel
Electrophoresis
(SDS-PAGE)*

PAGE is an electrophoretic technique that separates biological macromolecules based on surface charge and mass. An anionic detergent, sodium dodecyl sulfate (SDS), unfolds and binds strongly to proteins conferring a uniform mass-to-charge ratio [78]. SDS permits the separation of unfolded proteins by PAGE based on molecular weight (proportional to gel migration distance). PAGE is normally run under reducing conditions to remove any disulfide linkages that might affect protein unfolding. SDS-PAGE can also be run under nonreducing conditions, to monitor for the presence of disulfide bridges [79]. These nonreducing conditions can be used to study structural alterations due to disulfide mediated rHA aggregation. This protocol measures the formation of rHA multimers with SDS-PAGE analysis [51]. Four rHA H3 samples were examined for disulfide cross-linking by SDS-PAGE

analysis. Under nonreducing conditions on day 0, rHA H3 at 4 °C in the absence or presence of Triton™ X-100 (TX) began to form disulfide-linked multimers. The amount (band intensity) of the multimers did not increase significantly by day 28. rHA H3 stored at 25 °C had an increase in disulfide-related multimers over the same time period. The rHA H3 sample at 4 °C and in a 0.2 % sodium thioglycolate (STG) formulation, maintained predominantly monomeric bands (Fig. 2b).

To perform nonreduced SDS-PAGE analysis to detect rHA multimer formation, the following procedure is used:

1. Ten micrograms of each rHA sample is mixed with 2× laemmli buffer containing SDS (Bio-Rad, Hercules, CA).
2. Samples (MW standards, controls, and test samples) are heated at 98 °C for 5 min in the presence of laemmli buffer before SDS-PAGE analysis.
3. The rHA samples, and corresponding controls and standards, are separated using a 3–8 % Tris-Acetate gel (Invitrogen, Grand Island, NY, USA). Protein bands are visualized using Coomassie staining.
4. Bands of multimers or monomers observed in the SDS-PAGE gel can be quantified by gel densitometry based on the intensity of bands relative to a known concentration and known molecular weights of protein controls and standards.

3.3 Free Thiol Assay

Thiols in biological molecules (e.g., cysteine residues in proteins or peptides such as glutathione) are antioxidants with a strong reductive capacity and readily react with free radicals [41, 80, 81]. Cysteine residues in proteins can be easily oxidized into cystine residues forming disulfide crosslinks between two cysteine residues both within and between polypeptide chains. Disulfide cross-linking can lead to the formation of undesired multimers of proteins, which in turn can act as a catalyst for higher order aggregation events. Quantifying the amount of free thiols in proteins is important for determining the extent of oxidative modification that protein subunits in influenza VLPs and particle-like vaccines might have undergone. Free thiol detection kits are commercially available, and can be used in the presence of denaturants such as guanidine hydrochloride to monitor thiol content in unfolded proteins (Fig. 2c).

To measure free thiol content in rHA samples, the following steps are used:

1. Run a Measure-iT™ thiol assay (Invitrogen, Grand Island, NY, USA) in triplicate, using 50 µg of rHA sample for each experiment. The assay is performed following the manufacturer's protocol. Prepare Measure-iT™ thiol quantitation standards according to the manufacturer's dilution factors. Mix 10 µL of quantitation sample with 1–10 µL of rHA sample in a 96 or 384 well plate.

2. Place the microplate in a fluorescence plate reader (e.g., Spectramax Plus 384, Molecular Devices, Sunnyvale, CA, USA). At room temperature, excite the mixture at 494 nm, with emission being collected at 517 nm.
3. The quantification of free thiols is performed in the presence of 1.5 M guanidine-HCl, to induce partial or complete unfolding of the proteins.
4. The Measure-iT™ assay includes glutathione, which is used to quantify the amount of free thiols in rHA samples by plotting a glutathione standard curve.

3.4 Monitoring Conformational Stability and Potency of the HA Subunit under Freeze–Thaw and Freeze–Drying Stresses

The third case study looks at the formulation development of a stable inactivated influenza vaccine in the frozen and lyophilized state [53]. The influence of various carbohydrates, buffer types, and freezing rates on the integrity of the HA component of the vaccine (from strain A/Panama H3N2), after freeze-thawing or freeze-drying, were investigated. The HA component of inactivated vaccine can form particle-like structures, in the form of rosettes [82]. The use of fast freezing, HEPES buffer and carbohydrates (trehalose, inulin, or dextran) as cryo- and lyoprotectants resulted in a reduction of HA conformational changes as probed by the sensitivity of the HA antigen to trypsin digestion (Fig. 3a). The HA potency of the influenza subunit vaccine powders was monitored in different stabilizers for 26 weeks at room temperature as measured by the SRID assay (Fig. 3b).

3.4.1 Freeze–Thaw and Freezing–Rate Sensitivity of the HA Subunit

Freeze–thaw stresses stem from the instability of protein molecules at the ice–water interface, excipient phase separation, or thermal degradation upon exposure to thawing temperatures [22]. Formulation studies of multiple freeze–thaw cycles help isolate the freezing-related degradation events that may occur during lyophilization, storage, or shipment. Freeze–thaw studies can help identify cryo-protecting excipients that stabilize vaccine antigens [16, 83]. Freeze–thaw experiments can also provide insight into the cold sensitivity pathways of proteins, relative concentrations of protein and excipients, and buffer pH changes due to crystallization; these effects can vary depending on the geometry of the container and location placement in the freezer-storage shelves of lyophilizers [84]. Freezing rates may affect the relative concentration gradient of pro-

Fig. 3 (continued) were stored for 26 weeks at 20 °C 0%RH (*upper panels: i and ii*) or at 45 °C/11%RH (*lower panels: iii and iv*). Vaccine lyophilized powders containing either PBS and HEPES Buffered Saline (HBS) are presented in the *left (i and iii)* and *right panels (ii and iv)*, respectively. Vaccine is freeze-dried using rapid freezing without carbohydrate (*open circles*), with trehalose (*crosses*), inulin 0.9 kDa (*open triangles*), inulin 1.8 kDa (*closed diamonds*) or dextran 56 kDa (*closed squares*). Adapted from Amorij et al. [53], with permission from Elsevier

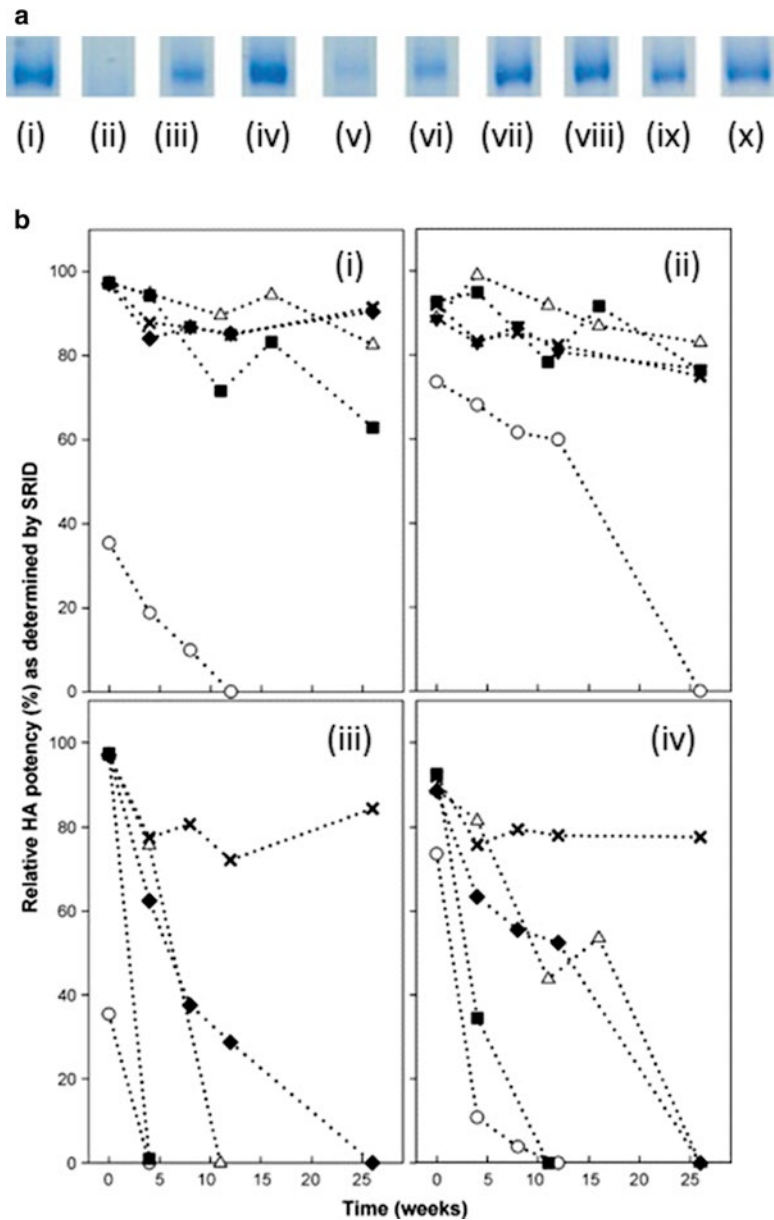

Fig. 3 Stability and potency of HA component of inactivated flu vaccine during freezing and freeze-drying. **(a)** Susceptibility of HA to trypsin digestion as measured by nonreducing SDS-PAGE. Shown are the HA monomer bands (~75 kDa) after different treatments. “Native HA” (i) and “acid-treated HA” (ii) are used as negative and positive control for the trypsin digestion, respectively. The effect of freeze-thawing and freeze-drying using different freezing rates and PBS buffer is shown in (iii, v): HA freeze-thawed using slow freezing (iii), freeze-thawed using rapid freezing (iv), freeze-dried using slow freezing (v) and freeze-dried using rapid freezing (vi). The effect of the different sugars using a rapid freezing rate and PBS is shown in (vii–x): HA freeze-dried with trehalose (vii), inulin 0.9 kDa (viii), inulin 1.8 kDa (ix) and dextran 56 kDa (x). **(b)** The effect of carbohydrate and buffer on the HA antigen stability of the freeze-dried subunit vaccine as measured by SRID. Samples

tein and excipients, with faster freezing (e.g., flash-freezing in liquid nitrogen) resulting in a more uniform distribution [15, 16]. The size and scale of the container can also affect homogeneity, with larger containers affecting uniform freezing rates, and/or the relative concentration distribution of excipient and protein components [85]. Aggregation nucleation points or surface-induced unfolding can also occur during the freezing process [15, 86, 87].

To conduct freeze–thaw studies of HA subunits in the presence of different additives, the following procedure is used:

1. Obtain clean, dust free glass vials, to prevent the creation of particle nucleation points during freezing. In this study [53], 4 mL glass vials are filled with 480 μL of 360 $\mu\text{g}/\text{mL}$ HA and 1.7 % (w/v) carbohydrate (or other excipients).
2. Two freezing rates are tested; slow freezing at $-20\text{ }^{\circ}\text{C}$ for 24 h, or flash-freezing in liquid nitrogen for 5–10 min. The samples are thawed at room temperature.
3. The crystallizing of buffers can result in a pH shift in the frozen matrix. To monitor this shift in pH during freezing, 20 μL universal indicator is added to HEPES and Phosphate buffered solutions in the presence and absence of carbohydrate excipients. The universal indicator consists of 0.02 % (w/v) methyl red, 0.02 % (w/v) phenolphthalein, 0.04 % (w/v) bromthymol blue, and 0.04 % (w/v) thymol blue in ethanol [53]. Small pH sensitive low-temperature probes can also be inserted into representative vials to monitor this shift [88].

3.4.2 Freeze-Drying of the HA Subunit

Freeze-drying can improve the storage stability of biologicals by transferring them from an aqueous phase to a dry phase, typically resulting in reduction of the rates of physical and chemical degradation [83, 89, 90]. The goal of freeze-drying of the HA subunit is to preserve immunogenicity and vaccine potency while maintaining long-term stability. The characteristics of a successful lyophilized product, in addition to maintaining the physicochemical and biological activity of the vaccine, also includes a uniform and pharmaceutically elegant cake (by visual confirmation), short resuspension time for use in the clinic, an absence of visible particulates upon resuspension, and low (but not excessively low) water content [91, 92].

Lyophilization consists of three main process steps: freezing, primary drying, and secondary drying [89]. The freezing step involves cooling the liquid suspension in vials until the water forms ice crystals and eventually freezes. The nonwater components in the suspension (containing vaccine antigen and excipients) undergo an increase in concentration and viscosity during the freezing step [92]. Based on the constituents of the liquid suspension, the freezing step can result in the formation of different phases: crystalline, amorphous, or amorphous-crystalline [91]. Primary drying introduces heat to the frozen vial, leading to the sublimation of the ice and

formation of water vapor [24]. Since ice sublimation proceeds from the top to the bottom of the vial, the water vapor passes through the dried protein and excipient matrix, out of the surface of the product, and from the chamber of the lyophilizer into a condenser. The resulting sample resembles a porous plug, with the pores corresponding to spaces previously occupied by ice crystals. The final step, secondary drying, removes much of the remnant water that did not freeze or sublimate and had been bound to the protein or excipients in the sample [83, 89]. Some bound water remains at the completion of the lyophilization process, with water levels typically measured by Karl Fischer titration [93], and the resulting values are commonly referred to as the residual moisture content.

Freeze-drying introduces stresses that can potentially destabilize the HA subunits during the freezing and drying steps [15, 24]. The freezing step can create phase separation of bulk water (ice) and highly concentrated HA subunit and excipient components [23]. High concentrations of protein or excipient can lead to protein destabilization and aggregation. Mechanical stresses from ice crystallization can also lead to changes in protein conformation [15]. To prevent the destabilization of HA during lyophilization and enhance storage stability, cryo-protecting excipients are added to mitigate freezing stress, and lyo-protectants to shield the protein from drying stresses [22, 83]. Common cryo and lyo-protecting excipients include sugars and polyols such as trehalose, sucrose, glucose, sorbitol, and mannitol [39, 40]. Vitrification of noncrystallizable excipients occurs at a temperature known as the glass transition temperature, T_g' [94]. To achieve a uniform and solid lyophilized cake without physical collapse, freezing is performed below the T_g' of the frozen amorphous phase, or if the components crystallize, below the eutectic crystallization temperature [89, 95, 96].

To obtain the glass transition temperature (T_g') value of a formulation using modulated differential scanning calorimetry, the following procedure is used, as described by Lewis et al. [97]:

1. A modulated differential scanning calorimeter (mDSC) is used to acquire the DSC thermogram, and has the advantage of measuring both heat flow and heat capacity, as well as the reversibility of thermal or freezing ramps [98]. The method compares the difference in modulation or oscillation of heating rate between a sample and a reference cell.
2. Hermetically sealed aluminum pans are prepared with 8–20 μL of formulation solution (reference), and formulation buffer with the HA antigen (sample). The weight of the aluminum pans after sample loading needs to be measured prior to the freezing run.
3. Purge the instrument with nitrogen gas at a flow rate of 50 mL/min (TA instruments, New Castle, DE, USA). The calorimetry run is performed in the modulated mode, with an amplitude of

0.75 °C, at intervals of 30 s. For the freezing run, the reference and sample pans are cooled to -80 °C at a rate of 2 °C/min, and then heated to 25 °C at a rate of 2 °C/min [97].

4. The T_g' of the amorphous phase can be calculated using TA Instruments Universal Analysis software. T_g' represents the midpoint transition of the freezing thermogram and is necessary for optimizing subsequent lyophilization cycles.

To lyophilize the HA subunit formulations, the following steps can be used:

1. Freeze dryers contain compartments or chambers in which low temperatures and pressures (regulated by vacuum pumps) can be achieved to lyophilize biologicals. The drying chamber is the main compartment which houses samples in vials on temperature-regulated shelves. A condenser chamber is attached by a valve to the drying chamber to remove excess water vapor from the drying chamber during sublimation [99]. Instruments such as the LyoStar II freeze dryer (or similar instruments) can be used for optimizing lyophilization cycles (i.e., temperature and pressure settings). See **Note 6**.
2. The glass vials can range in size and volume (for example, 3–20 mL fill volumes) (Wheaton, Millville, NJ). Recommended maximum fill volumes are 35 % of vial capacity [100]. For example, Lewis et al. [97] filled a 3 mL vial with 1 mL of sample solution, resulting in a fill depth of 0.75 cm. A ring of empty vials can be placed around the solution-containing vials to help reduce “edge effects” during drying [101].
3. The glass vials should be covered with pharmaceutical rubber stoppers (Wheaton, Millville, NJ) that are partially inserted to permit for the sublimation of water vapor from the vial into the condenser chamber [101]. Rubber stopper sizes are based on the neck diameter of the glass vials (e.g., 13 or 20 mm).
4. Thermocouples are inserted into the glass vials to monitor the change in sample temperature during freezing and drying cycles. The placement of thermocouples in the vials is important, since any physical contact with the glass vial will not be representative of the solution temperature. Therefore, thermocouples should be placed in the center of the vials, near the bottom.
5. Thermocouples should be distributed evenly among the glass vials to get an adequate sampling of the influence of vial placement (temperature effects on placement in the edge or center of the shelf) [97, 99]. Different size gauges of thermocouples can be used (Omega, Newport, CT). The thermocouples should be calibrated on an annual basis [97] [102].
6. Lyophilization cycles values for shelf temperature (and ramp rates) and chamber pressure depend on the T_g' value of the solution matrix being dried. The solution T_g' value is dictated by the

combination of the additives in the solution and their individual T_g' values of each component (e.g., sucrose has a T_g' of $-32\text{ }^\circ\text{C}$, and mannitol has a T_g' of $-40\text{ }^\circ\text{C}$) [103]. For example, a general lyophilization cycle is here adapted from Lewis et al. [97]:

- (a) Freezing step [104]: The protein solution is frozen from room temperature to $-45\text{ }^\circ\text{C}$, with a ramp rate of $1\text{ }^\circ\text{C}/\text{min}$. The vials are held at this shelf temperature for 2 h to ensure complete freezing [97].
- (b) Annealing step [94]: The sample vials are heated by raising the shelf temperature to $-20\text{ }^\circ\text{C}$ at a ramp rate of $1\text{ }^\circ\text{C}/\text{min}$ and maintained at that temperature for 1 h. The shelf temperature is then cooled back to $-45\text{ }^\circ\text{C}$ at a ramp rate of $1\text{ }^\circ\text{C}/\text{min}$, maintaining the shelf temperature for 2 h to again ensure complete freezing [97].
- (c) Primary drying step [99]: This is the process where sublimation of water from solid to vapor occurs by lowering the pressure. Sample vials are heated to initiate primary drying by raising the shelf to $-25\text{ }^\circ\text{C}$, at a rate of $0.3\text{ }^\circ\text{C}/\text{min}$ from the $-45\text{ }^\circ\text{C}$ setting, with the lyophilizer chamber pressure at 57–60 mTorr. The heating rate and overall primary drying time is modified based on an aggressive (1000–1500 min) or conservative cycle timeline (3000–4000 min) to ensure varying levels of adequate sublimation of the bulk water in the sample [97].
- (d) Secondary drying step [24]: To remove much of the residual bound water, the shelf temperature is set to $30\text{ }^\circ\text{C}$ for 10 h, at a $0.2\text{ }^\circ\text{C}/\text{min}$ ramp rate. Chamber pressures are maintained at 57–60 mTorr [97]. The final secondary drying shelf temperature should be determined by the thermal stability of the HA antigen, ensuring thermal degradation does not occur during secondary drying.

3.4.3 Monitoring Conformation Stability and Potency of HA Subunits by Proteolytic Cleavage and SRID Assays

HA antigen is resistant to trypsin digestion in its native conformation, but becomes susceptible to protease cleavage under acidic conditions [105]. The effect of freezing, buffers, and cryoprotectants on the pH-induced conformational changes of HA subunits can be tested by a proteolysis assay, followed by SDS-PAGE to resolve and quantify the amount of cleaved species [53]. SRID potency assays can test the effect of freeze-drying on the short-term storage efficacy of the HA subunits in different buffers and excipients (Fig. 3).

To evaluate the presence of an acid-induced conformational change of HA subunits after freezing and freeze-drying, proteolytic trypsin and SRID assays are performed as follows:

1. Ninety microgram per milliliter of HA subunits is incubated with $100\text{ }\mu\text{g}/\text{mL}$ of trypsin for 1 h, at neutral pH (7.4) and

37 °C. The proteolysis reaction is stopped with a 200 µg/mL trypsin-inhibitor [53].

2. The HA antigen sample, containing 3.6 µg protein, is boiled with SDS-PAGE loading buffer for 5 min. The buffer/HA mix (8–15 µL) is loaded on to 10 % polyacrylamide gels (Fermentas, Waltham, MA, USA). SDS-PAGE electrophoresis separates HA, viral proteins and protein fragments under nonreducing conditions [53]. Proteins can be stained with a Coomassie or PAGE blue staining solution (Fermentas, Waltham, MA, USA) (Fig. 3a).
3. A SRID assay (Subheading 3.2, step 1) is used to test the potency of the freeze-dried HA antigen immediately after freeze-drying and after freeze-drying and storage. In this study [53], samples were stored up to 26 weeks at 20 °C/0 % relative humidity (RH) (using a silica containing vacuum desiccator in climate controlled room) or at 45 °C/11 ± 2 % RH in a climate cabinet (Fig. 3b).

4 Notes

1. It should be noted that the effective diameter calculated by this method is accurate for particles of less than 1-µm diameter; the values obtained from measurements of larger particles should be used for qualitative comparison only. Other instruments are available for a measurement of larger aggregates, such as sub-micron (~0.1–1 µm)- and subvisible (~1–100 µm)-sized particles (for example, submicron particle tracking (NTA), light obscuration, optical microscopy, flow imaging analysis, and electrozone sensing/Coulter counter) [106].
2. Fourier transform infrared or UV-resonance Raman spectroscopy can also be used to determine the overall secondary structure content of the VLPs [107].
3. Peak position picking by Mean Spectral Center of Mass (MSM) calculates the spectral centroid (ν_p) as an estimate of the intensity (area) and wavelength position of a spectral peak [108].

$$\left(\nu_p\right) = \frac{\sum_i F_i \nu_i}{\sum_i F_i}$$

F_i represents the intrinsic tryptophan fluorescence emission at wavelength ν_i [63, 108]. Summation is performed over the full emission spectrum (approximately 310–400 nm). The indole side chain on tryptophan exhibits spectral properties dependent on the polarity of the local environment. An apolar environment results in a tryptophan emission peak below 340 nm. Peak shifting to 340–355 nm is an indication of exposure of the tryptophan to a polar environment, e.g. residue exposed to aqueous solvents. The indole side chain has two isoenergetic

transitions that can be selectively activated, leading to sensitivity of the tryptophan emission spectrum. Other aromatic amino acid residues, such as tyrosine and phenylalanine, are not as sensitive to detection because they have single electronic states and much weaker emission [63].

4. Static light scattering can simultaneously be monitored at 295 nm, indicating if aggregation is occurring during the thermal melt. This can simply be done by using a photomultiplier tube (PMT) oriented 180° to the fluorescence emission detector.
5. In laurdan fluorescence, generalized polarization (GP) is defined as,

$$GP = (I_{440} - I_{480}) / (I_{440} + I_{480})$$

where I_x is the fluorescence intensity at wavelength x [67, 109]. Decreasing GP values indicate an increase in membrane fluidity, and vice versa.

6. The freezing and drying cycles (ramp rates, etc.) must be optimized for protein stability [90], water content (e.g. by Karl Fischer titration [93]), and the desired biological potency of the vaccine antigen. It has recently been demonstrated that lyophilization can be performed in the presence of aluminum salt adjuvants. *See* Carpenter et al. for a discussion of this procedure [110].

References

1. Johnson JE, Chiu W (2000) Structures of virus and virus-like particles. *Curr Opin Struct Biol* 10:229–235
2. Caspar DT, Klug A (1962) Physical principles in the construction of regular viruses. In: *Cold Spring Harbor symposia on quantitative biology*. Cold Spring Harbor Laboratory Press, Cold Spring Harbor, NY, pp 1–24
3. Baschong W, Hasler L, Häner M, Kistler J, Aepli U (2003) Repetitive versus monomeric antigen presentation: direct visualization of antibody affinity and specificity. *J Struct Biol* 143:258–262
4. Chackerian B (2007) Virus-like particles: flexible platforms for vaccine development. *Expert Rev Vaccines* 6:381–390
5. Bachmann MF, Jennings GT (2010) Vaccine delivery: a matter of size, geometry, kinetics and molecular patterns. *Nat Rev Immunol* 10:787–796
6. McAleer WJ, Buynak EB, Maigetter RZ, Wampler DE, Miller WJ, Hilleman MR (1984) Human hepatitis B vaccine from recombinant yeast. *Nature* 307:178–180
7. Jain NK, Sahni N, Kumru OS, Joshi SB, Volkin DB, Middaugh CR (2014) Formulation and stabilization of recombinant protein based virus-like particle vaccines. *Adv Drug Delivery* 19:42–55
8. Roldão A, Mellado MCM, Castilho LR, Carrondo MJ, Alves PM (2010) Virus-like particles in vaccine development. *Expert Rev Vaccines* 9:1149–1176
9. Lua LH, Connors NK, Sainsbury F, Chuan YP, Wibowo N, Middaugh AP (2014) Bioengineering virus-like particles as vaccines. *Biotechnol Bioeng* 111:425–440
10. Ausar SF, Foubert TR, Hudson MH, Vedvick TS, Middaugh CR (2006) Conformational stability and disassembly of Norwalk virus-like particles effect of pH and temperature. *J Biol Chem* 281:19478–19488
11. Mach H, Volkin DB, Troutman RD, Wang B, Luo Z, Jansen KU, Shi L (2006) Disassembly and reassembly of yeast-derived recombinant human papillomavirus virus-like particles (HPV VLPs). *J Pharm Sci* 95:2195–2206

12. Cleland JL, Powell MF, Shire SJ (1992) The development of stable protein formulations: a close look at protein aggregation, deamidation, and oxidation. *Crit Rev Ther Drug Carrier Syst* 10:307–377
13. Shire SJ (2009) Formulation and manufacturability of biologics. *Curr Opin Biotechnol* 20:708–714
14. Hasija M, Li L, Rahman N, Ausar SF (2013) Forced degradation studies: an essential tool for the formulation development of vaccines. *Vaccine* 3:11–33
15. Bhatnagar BS, Bogner RH, Pikal MJ (2007) Protein stability during freezing: separation of stresses and mechanisms of protein stabilization. *Pharm Dev Technol* 12:505–523
16. Carpenter JF, Crowe JH (1988) The mechanism of cryoprotection of proteins by solutes. *Cryobiology* 25:244–255
17. Myers JK, Nick Pace C, Martin Scholtz J (1995) Denaturant m values and heat capacity changes: relation to changes in accessible surface areas of protein unfolding. *Protein Sci* 4:2138–2148
18. Cromwell ME, Hilario E, Jacobson F (2006) Protein aggregation and bioprocessing. *AAPS J* 8:E572–E579
19. Permyakov EA, Burstein EA (1984) Some aspects of studies of thermal transitions in proteins by means of their intrinsic fluorescence. *Biophys Chem* 19:265–271
20. Telikepalli S, Kumru OS, Kim JH, Joshi SB, O’Berry KB, Blake-Haskins AW, Perkins MD, Middaugh CR, Volkin DB (2015) Characterization of the physical stability of a lyophilized IgG1 mAb after accelerated shipping-like stress. *J Pharm Sci* 104:495–507
21. Frokjaer S, Otzen DE (2005) Protein drug stability: a formulation challenge. *Nat Rev Drug Discov* 4:298–306
22. Kumru OS, Joshi SB, Smith DE, Middaugh CR, Prusik T, Volkin DB (2014) Vaccine instability in the cold chain: mechanisms, analysis and formulation strategies. *Biologicals* 42:237–259
23. Randolph TW (1997) Phase separation of excipients during lyophilization: effects on protein stability. *J Pharm Sci* 86:1198–1203
24. Luthra S, Obert JP, Kalonia DS, Pikal MJ (2007) Investigation of drying stresses on proteins during lyophilization: differentiation between primary and secondary-drying stresses on lactate dehydrogenase using a humidity controlled mini freeze-dryer. *J Pharm Sci* 96:61–70
25. Chang BS, Hershenson S (2002) Practical approaches to protein formulation development. In: *Rational design of stable protein formulations*. Springer, New York, NY, pp 1–25
26. Rowe RC, Sheskey PJ, Quinn ME (2009) *Handbook of pharmaceutical excipients*, vol 6. Pharmaceutical Press, London
27. Kamerzell TJ, Esfandiary R, Joshi SB, Middaugh CR, Volkin DB (2011) Protein–excipient interactions: mechanisms and biophysical characterization applied to protein formulation development. *Adv Drug Deliv Rev* 63:1118–1159
28. Pincoa RG, Sullivanb TM (2006) Regulation of pharmaceutical excipients. *Excipient development for pharmaceutical, biotechnology, and drug delivery systems*. CRC Press, Boca Raton, FL
29. Kossiakoff A (1988) Tertiary structure is a principal determinant to protein deamidation. *Science* 240:191–194
30. Brazeau GA, Cooper B, Svetic KA, Smith CL, Gupta P (1998) Current perspectives on pain upon injection of drugs. *J Pharm Sci* 87:667–677
31. Chowdhuri S, Chandra A (2001) Molecular dynamics simulations of aqueous NaCl and KCl solutions: effects of ion concentration on the single-particle, pair, and collective dynamical properties of ions and water molecules. *J Chem Phys* 115:3732–3741
32. Arakawa T, Timasheff S (1985) The stabilization of proteins by osmolytes. *Biophys J* 47:411
33. Arakawa T, Tsumoto K, Kita Y, Chang B, Ejima D (2007) Biotechnology applications of amino acids in protein purification and formulations. *Amino Acids* 33:587–605
34. Arakawa T, Timasheff SN (1983) Preferential interactions of proteins with solvent components in aqueous amino acid solutions. *Arch Biochem Biophys* 224:169–177
35. Chen B, Bautista R, Yu K, Zapata GA, Mulkerrin MG, Chamow SM (2003) Influence of histidine on the stability and physical properties of a fully human antibody in aqueous and solid forms. *Pharm Res* 20:1952–1960
36. Falconer RJ, Chan C, Hughes K, Munro TP (2011) Stabilization of a monoclonal antibody during purification and formulation by addition of basic amino acid excipients. *J Chem Technol Biotechnol* 86:942–948
37. Kanazawa H, Fujimoto S, Ohara A (1994) Effect of radical scavengers on the inactivation

- of papain by ascorbic acid in the presence of cupric ions. *Biol Pharm Bull* 17:476–481
38. Trivedi MV, Laurence JS, Siahaan TJ (2009) The role of thiols and disulfides in protein chemical and physical stability. *Curr Protein Pept Sci* 10:614
 39. Back JF, Oakenfull D, Smith MB (1979) Increased thermal stability of proteins in the presence of sugars and polyols. *Biochemistry* 18:5191–5196
 40. Arakawa T, Timasheff SN (1982) Stabilization of protein structure by sugars. *Biochemistry* 21:6536–6544
 41. Stadtman E (1993) Oxidation of free amino acids and amino acid residues in proteins by radiolysis and by metal-catalyzed reactions. *Annu Rev Biochem* 62:797–821
 42. Li S, Schöneich C, Borchardt RT (1995) Chemical instability of protein pharmaceuticals: mechanisms of oxidation and strategies for stabilization. *Biotech Bioeng* 48:490–500
 43. Shi L, Sanyal G, Ni A, Luo Z, Doshna S, Wang B, Graham TL, Wang N, Volkin DB (2005) Stabilization of human papillomavirus virus-like particles by non-ionic surfactants. *J Pharm Sci* 94:1538–1551
 44. Krägel J, O'Neill M, Makievski A, Michel M, Leser M, Miller R (2003) Dynamics of mixed protein–surfactant layers adsorbed at the water/air and water/oil interface. *Colloids Surf B Biointerfaces* 31:107–114
 45. Kerwin BA (2008) Polysorbates 20 and 80 used in the formulation of protein biotherapeutics: structure and degradation pathways. *J Pharm Sci* 97:2924–2935
 46. Dewez J-L, Berger V, Schneider Y-J, Rouxhet PG (1997) Influence of substrate hydrophobicity on the adsorption of collagen in the presence of pluronic F68, albumin, or calf serum. *J Colloid Interface Sci* 191:1–10
 47. Gross P, Ennis F, Gaerlan P, Denning C, Setia U, Davis W, Bisberg D (1981) Comparison of new triton X-100-and tween-ether-treated split-treated vaccines in children. *J Clin Microbiol* 14:534–538
 48. Heinig K, Vogt C (1997) Determination of Triton X-100 in influenza vaccine by high-performance liquid chromatography and capillary electrophoresis. *Fresenius J Anal Chem* 359:202–206
 49. Oncley J, Ellenbogen E, Gitlin D, Gurd F (1952) Protein–protein interactions. *J Phys Chem* 56:85–92
 50. Kissmann J, Joshi SB, Haynes JR, Dokken L, Richardson C, Middaugh CR (2011) H1N1 influenza virus-like particles: physical degradation pathways and identification of stabilizers. *J Pharm Sci* 100:634–645
 51. Hickey JM, Holtz KM, Manikwar P, Joshi SB et al (2014) Mechanism of a decrease in potency for the recombinant influenza A virus hemagglutinin H3 antigen during storage. *J Pharm Sci* 103:821–827
 52. Feshchenko E, Rhodes DG, Felberbaum R, McPherson C, Rininger JA, Post P, Cox MM (2012) Pandemic influenza vaccine: characterization of A/California/07/2009 (H1N1) recombinant hemagglutinin protein and insights into H1N1 antigen stability. *BMC Biotechnol* 12:77
 53. Amorij J, Meulenaar J, Hinrichs W, Stegmann T, Huckriede A, Coenen F, Frijlink H (2007) Rational design of an influenza subunit vaccine powder with sugar glass technology: preventing conformational changes of haemagglutinin during freezing and freeze-drying. *Vaccine* 25:6447–6457
 54. Goldberg W (1999) Dynamic light scattering. *Am J Phys* 67:1152–1160
 55. Berne BJ, Pecora R (2000) Dynamic light scattering: with applications to chemistry, biology, and physics. Courier Corporation, Mineola, NY
 56. Pecora R (1985) Dynamic light scattering: applications of photon correlation spectroscopy. Springer Science & Business Media, New York, NY
 57. Edward JT (1970) Molecular volumes and the Stokes-Einstein equation. *J Chem Educ* 47:261
 58. Shiba K, Niidome T, Katoh E, Xiang H, Han L, Mori T, Katayama Y (2010) Polydispersity as a parameter for indicating the thermal stability of proteins by dynamic light scattering. *Anal Sci* 26:659–663
 59. Fasman GD (1996) Circular dichroism and the conformational analysis of biomolecules. Plenum Press, New York, NY
 60. Greenfield NJ, Fasman GD (1969) Computed circular dichroism spectra for the evaluation of protein conformation. *Biochemistry* 8:4108–4116
 61. Provencher SW, Gloeckner J (1981) Estimation of globular protein secondary structure from circular dichroism. *Biochemistry* 20:33–37
 62. Kelly SM, Jess TJ, Price NC (2005) How to study proteins by circular dichroism. *Biochim Biophys Acta* 1751:119–139
 63. Lakowicz JR (2007) Principles of fluorescence spectroscopy. Springer Science & Business Media, New York, NY

64. Hawe A, Sutter M, Jiskoot W (2008) Extrinsic fluorescent dyes as tools for protein characterization. *Pharm Res* 25:1487–1499
65. Rodrigues JV, Prosiński V, Marrucho I, Rebelo LPN, Gomes CM (2011) Protein stability in an ionic liquid milieu: on the use of differential scanning fluorimetry. *Phys Chem Chem Phys* 13:13614–13616
66. Niesen FH, Berglund H, Vedadi M (2007) The use of differential scanning fluorimetry to detect ligand interactions that promote protein stability. *Nat Protoc* 2:2212–2221
67. Parasassi T, De Stasio G, Ravagnan G, Rusch R, Gratton E (1991) Quantitation of lipid phases in phospholipid vesicles by the generalized polarization of Laurdan fluorescence. *Biophys J* 60:179
68. Chapman D (1975) Phase transitions and fluidity characteristics of lipids and cell membranes. *Q Rev Biophys* 8:185–235
69. Golub GH, Reinsch C (1970) Singular value decomposition and least squares solutions. *Numer Math* 14:403–420
70. Maddux NR, Joshi SB, Volkin DB, Ralston JP, Middaugh CR (2011) Multidimensional methods for the formulation of biopharmaceuticals and vaccines. *J Pharm Sci* 100:4171–4197
71. Cox MM, Hollister JR (2009) FluBlok, a next generation influenza vaccine manufactured in insect cells. *Biologicals* 37:182–189
72. Treanor JJ, El Sahly H, King J, Graham I, Izikson R, Kohberger R, Patriarca P, Cox M (2011) Protective efficacy of a trivalent recombinant hemagglutinin protein vaccine (FluBlok®) against influenza in healthy adults: a randomized, placebo-controlled trial. *Vaccine* 29:7733–7739
73. Wood J, Schild G, Newman R, Seagroatt V (1977) An improved single-radial-immunodiffusion technique for the assay of influenza haemagglutinin antigen: application for potency determinations of inactivated whole virus and subunit vaccines. *J Biol Stand* 5:237–247
74. Wood J, Dunleavy U, Newman R, Riley A, Robertson J, Minor P (1998) The influence of the host cell on standardisation of influenza vaccine potency. *Dev Biol Stand* 98:183–188, discussion 197
75. Williams M, Mayner R, Daniel N, Phelan M, Rastogi S, Bozeman F, Ennis F (1980) New developments in the measurement of the hemagglutinin content of influenza virus vaccines by single-radial-immunodiffusion. *J Biol Stand* 8:289–296
76. Berne BH (1974) Differing methodology and equations used in quantitating immunoglobulins by radial immunodiffusion—a comparative evaluation of reported and commercial techniques. *Clin Chem* 20:61–69
77. Mancini G, Carbonara A, Heremans J (1965) Immunochemical quantitation of antigens by single radial immunodiffusion. *Immunochemistry* 2:235–IN236
78. Shapiro AL, Viñuela E, Maizel JV (1967) Molecular weight estimation of polypeptide chains by electrophoresis in SDS-polyacrylamide gels. *Biochem Biophys Res Commun* 28:815–820
79. Schägger H, Von Jagow G (1987) Tricine-sodium dodecyl sulfate-polyacrylamide gel electrophoresis for the separation of proteins in the range from 1 to 100 kDa. *Anal Biochem* 166:368–379
80. Reed D, Babson J, Beatty P, Brodie A, Ellis W, Potter D (1980) High-performance liquid chromatography analysis of nanomole levels of glutathione, glutathione disulfide, and related thiols and disulfides. *Anal Biochem* 106:55–62
81. Stadtman ER, Levine RL (2000) Protein oxidation. *Ann N Y Acad Sci* 899:191–208
82. Skehel J, Bayley P, Brown E, Martin S, Waterfield M, White J, Wilson I, Wiley D (1982) Changes in the conformation of influenza virus hemagglutinin at the pH optimum of virus-mediated membrane fusion. *Proc Natl Acad Sci* 79:968–972
83. Carpenter JF, Pikal MJ, Chang BS, Randolph TW (1997) Rational design of stable lyophilized protein formulations: some practical advice. *Pharm Res* 14:969–975
84. Privalov PL (1990) Cold denaturation of protein. *Crit Rev Biochem Mol Biol* 25:281–306
85. Singh SK, Kolhe P, Wang W, Nema S (2009) Large-scale freezing of biologics. *BioProcess Int* 7:34–42
86. Cao E, Chen Y, Cui Z, Foster PR (2003) Effect of freezing and thawing rates on denaturation of proteins in aqueous solutions. *Biotechnol Bioeng* 82:684–690
87. Chang BS, Kendrick BS, Carpenter JF (1996) Surface-induced denaturation of proteins during freezing and its inhibition by surfactants. *J Pharm Sci* 85:1325–1330
88. Larsen S (1973) Studies on stability of drugs in frozen systems. VI. The effect of freezing upon pH for buffered aqueous solutions. *Arch Pharm Chem Sci Ed* 1:41–53
89. Costantino HR, Pikal MJ (2004) Lyophilization of biopharmaceuticals, vol 2.

- Springer Science & Business Media, New York, NY
90. Rexroad J, Wiethoff CM, Jones LS, Middaugh CR (2002) Lyophilization and the thermostability of vaccines. *Cell Preserv Technol* 1:91–104
 91. Matejtschuk P (2007) Lyophilization of proteins. In: Cryopreservation and freeze-drying protocols. Springer, New York, NY, pp 59–72
 92. Lang R, Winter G, Vogt L, Zürcher A, Dorigo B, Schimmele B (2009) Rational design of a stable, freeze-dried virus-like particle-based vaccine formulation. *Drug Dev Ind Pharma* 35:83–97
 93. Ruiz RP (2001) Karl Fischer titration. *Current protocols in food analytical chemistry A:A1:A1.2*
 94. Searles JA, Carpenter JF, Randolph TW (2001) Annealing to optimize the primary drying rate, reduce freezing-induced drying rate heterogeneity, and determine T_g' in pharmaceutical lyophilization. *J Pharm Sci* 90:872–887
 95. Rey LR (1960) Thermal analysis of eutectics in freezing solutions. *Ann N Y Acad Sci* 85:510–534
 96. Patel RM, Hurwitz A (1972) Eutectic temperature determination of preformulation systems and evaluation by controlled freeze drying. *J Pharm Sci* 61:1806–1810
 97. Lewis LM, Johnson RE, Oldroyd ME, Ahmed SS, Joseph L, Saracovan I, Sinha S (2010) Characterizing the freeze-drying behavior of model protein formulations. *AAPS PharmSciTech* 11:1580–1590
 98. Gill P, Sauerbrunn S, Reading M (1993) Modulated differential scanning calorimetry. *J Therm Anal Calorim* 40:931–939
 99. Patel SM, Doen T, Pikal MJ (2010) Determination of end point of primary drying in freeze-drying process control. *AAPS Pharm Sci Tech* 11:73–84
 100. Bhambhani A, Medi BM (2010) LYOPHILIZATION: selection of containers/closures for use in lyophilization applications: possibilities and limitations. *Am Pharm Rev* 13:86
 101. Pikal M, Roy M, Shah S (1984) Mass and heat transfer in vial freeze-drying of pharmaceuticals: role of the vial. *J Pharm Sci* 73:1224–1237
 102. Burns GW, Scroger MG (1989) The calibration of thermocouples and thermocouple materials, vol 250–35. National Institute of Standards and Technology, US Department of Commerce, Gaithersburg, MD
 103. Wang W (2000) Lyophilization and development of solid protein pharmaceuticals. *Int J Pharm* 203:1–60
 104. Patapoff TW, Overcashier DE (2002) The importance of freezing on lyophilization cycle development. *BioPharm* 15:16–21
 105. Carr CM, Chaudhry C, Kim PS (1997) Influenza hemagglutinin is spring-loaded by a metastable native conformation. *Proc Natl Acad Sci U S A* 94:14306–14313
 106. Singh SK, Toler MR (2012) Monitoring of subvisible particles in therapeutic proteins. In: *Therapeutic proteins*. Springer, New York, NY, pp 379–401
 107. Pelton JT, McLean LR (2000) Spectroscopic methods for analysis of protein secondary structure. *Anal Biochem* 277:167–176
 108. Cordes MH, Sauer RT (1999) Tolerance of a protein to multiple polar-to-hydrophobic surface substitutions. *Protein Sci* 8:318–325
 109. Parasassi T, De Stasio G, d'Ubaldo A, Gratton E (1990) Phase fluctuation in phospholipid membranes revealed by Laurdan fluorescence. *Biophys J* 57:1179
 110. Clausi AL, Merkley SA, Carpenter JF, Randolph TW (2008) Inhibition of aggregation of aluminum hydroxide adjuvant during freezing and drying. *J Pharm Sci* 97:2049–2061

Strategies for Vaccine Design Using Phage Display-Derived Peptides

Luiz R. Goulart and Paula de S. Santos

1 Introduction

The phage display technology (PD), a selection strategy of polypeptides displayed in the surface of filamentous bacteriophage against targets, was introduced in 1985 by George Smith. PD is based on DNA recombination, resulting in expression of foreign peptide variants on the outer surface of phage clones [1]. Using an in vitro selection process based on binding affinity, or biopanning, the ligands are eluted from targets and enriched under many cycles of selection. The exposed peptides in the selected phage clones are characterized by DNA sequencing and then identified [2].

Phage-displayed peptide libraries became one of the most powerful technologies for selecting peptide ligands for specific target molecules [3]. The random peptides fused to the bacteriophage capsid selected against a specific target are considered mimetic in relation to their native epitopes and can be used as antigenic and immunogenic molecules. Immunogenic carriers are able to generate antibodies against recombinant peptides expressed in the N-terminal region of the phage surface, which may cross-react with the native antigen target, suggesting that expressed mimotopes can be used as candidate vaccinal subunits.

Differently from working with entire proteins or whole organisms in conventional vaccines with multiple epitopes and unnecessary antigenic load, peptide vaccines are an attractive strategy that relies on short peptides to induce highly targeted immune responses. The single immunogenic region of the phage-fused peptide is able to eliminate cross-reactions and avoid allergic responses, which are usually observed in complex antigens that share common epitopes with other proteins. Besides, it may facilitate production as a recombinant or chemically synthesized antigen subunit for vaccinal purposes without the large-scale

purification strategy needed for whole proteins [4–6]. The present chapter presents protocols for identification of highly reactive peptides against antibodies based on phage display and procedures to demonstrate their potential as immunogens in vaccine formulations (Fig. 1).

2 Materials

2.1 Peptide Selection Components

1. Coating buffer: 0.1 M NaHCO₃, pH 8.6.
2. Polystyrene microplates (Nunc Maxisorp).
3. PhD-12 or PhD-C7C phage library (New England Biolabs, Beverly, MA, USA). Store at –20 °C.
4. Tris-buffered saline (TBS): 50 mM Tris–HCl, pH 7.5, 150 mM NaCl. Sterilize by autoclaving 20 min at 15 psi.
5. Blocking solution (TBS/BSA 3 %): add 3 g of BSA (bovine serum albumin) to 100 mL with TBS.
6. Washing solution (TBS-T 0.1 %): add 1 mL of Tween 20 to 1 L with TBS.
7. Elution buffer: 0.2 M glycine in water. Adjust pH to 2.2 with HCl. Add 1 mg/mL of BSA. Sterilize by filtration and store at 4 °C.
8. Neutralization buffer: 1 M Tris base. Adjust pH to 9.1 with HCl. Store at 4 °C.
9. *Escherichia coli* ER2738 strain (New England Biolabs, Beverly, MA, USA). Store at –70 °C.
10. LB (Luria broth) powder: 10 g of tryptone, 5 g of yeast extract, and 25 g of NaCl. Sterilize by autoclaving. Store at room temperature.
11. LB medium: 2 % of LB powder with water. Sterilize by autoclaving.
12. LB powder: dissolve 10 g of tryptone, 5 g of yeast extract, and 5 g of NaCl in 1 L of water. Sterilize by autoclaving.
13. Tetracycline stock: dissolve 20 mg in 1 mL of ethanol. Store at –20 °C in the dark.
14. PEG/NaCl: add 20 % of polyethylene glycol-8000 and 2.5 M of NaCl in water. Sterilize by autoclaving. Store at room temperature.
15. Phosphate-buffered saline (PBS): 137 mM NaCl, 2.7 mM KCl, 12 mM Na₂HPO₄, 1.2 mM KH₂PO₄, pH 7.4 with HCl. Sterilize by autoclaving.

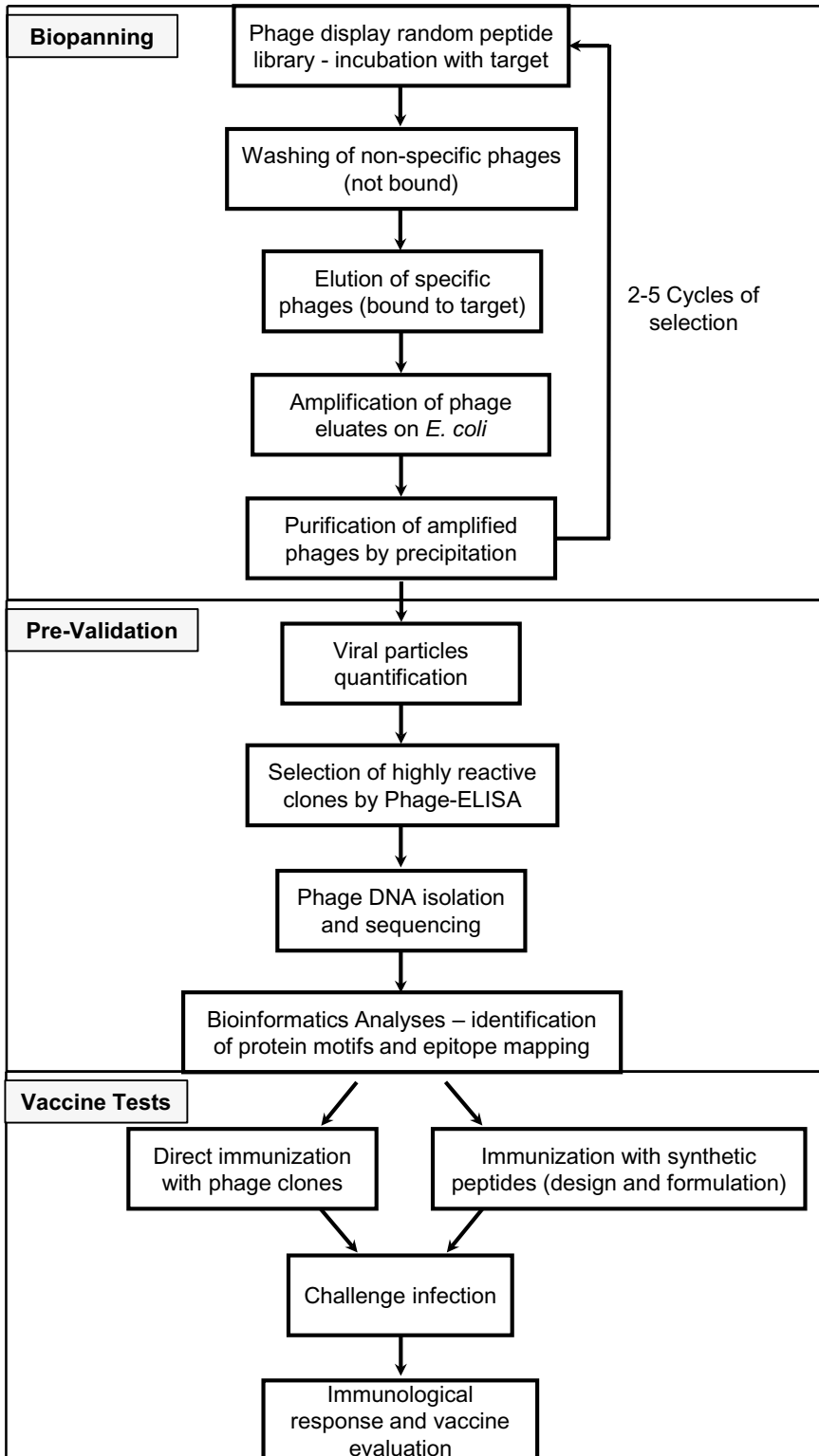

Fig. 1 Schematic procedures for the identification and characterization of peptides selected by phage display and to further demonstrate their potential application as immunogenic agents in vaccine formulations

16. LB top agar: add 2 g of LB powder, 1 of $\text{MgCl}_2 \cdot 6\text{H}_2\text{O}$ and 7 g of Bacto Agar to 1 L of water. Sterilize by autoclaving.
17. LB agar plates: Add 20 g of LB powder and 15 g of Bacto Agar to 1 L of water. Sterilize by autoclaving.
18. IPTG: 200 mg of IPTG (isopropyl- β -d-thiogalactoside) in 1 mL of distilled water. Filter-sterilize. Store at -20°C in the dark.
19. X-Gal: 20 mg of X-Gal in 1 mL of dimethylformamide. Store at -20°C in the dark.
20. Petri dishes.
21. 96-well Maxisorp™ microtiter plate (NUNC, NY, USA).
22. Carbonate buffer: 0.1 M NaHCO_3 . Adjust the pH to 8.6. Store at 4°C .
23. 96-deepwell plate.
24. HRP-conjugated anti-M13 (Roche Applied Science).
25. OPD-containing solution: to prepare 5 mL of solution, add 20 mg of OPD (*O*-phenylenediamine dihydrochloride), 2 μL of H_2O_2 , and 5 mL of citrate-phosphate buffer (2.6 g citric acid, 6.9 g Na_2HPO_4 , up to 500 mL with purified H_2O , pH 5.0).
26. 4 M H_2SO_4 .
27. Microplate spectrophotometer.
28. Centrifuge with rotor to microtube, 50 mL tube and microtiter plate.
29. Iodide buffer: 10 mM Tris-HCl, pH 8.0, 1 mM EDTA, 4 M NaI. After dissolved, store in the dark at room temperature.

**2.2 Immunization
and Immunological
Response
Identification
Components**

1. 6-week female BALB/c mice.
2. Needles.
3. Syringes of 1–3 and 5 mL capacity.
4. Falcon tube 15 mL.
5. 96-well culture plate.
6. Neubauer chamber.
7. Trypan blue solution.
8. CFSE (carboxyfluorescein succinimidyl ester).
9. Con A (Concanavalin A).
10. Lysis buffer: mix nine parts of solution 1 (0.16 M NH_4Cl , complete for 1 L with sterile water) and 1 part of solution 2 (0.17 M Tris base, adjust pH to 7.2 with HCl, complete for 1 L with sterile water), filter, and store at 4°C .
11. Incomplete medium: add 0.1 % gentamicin to RPMI 1640 culture medium.
12. Complete medium: add 10 % fetal bovine serum (FBS) and 0.1 % gentamicin to RPMI 1640 culture medium.

13. Peroxidase-labeled goat anti-mouse IgG, IgG1, and IgG2a antibodies.
14. Horseradish peroxidase enzyme.

3 Methods

For vaccine design, PD-derived peptides can be used as target for selection of mimotopes against monoclonal or polyclonal antibodies, since peptides will mimic the antigen-binding site of such antibodies. A mimotope with pathogen neutralization capabilities must be selected and analyzed in vitro prior to test as a vaccine immunogen. Therefore, the chosen target and strategies for selection and analyses will depend on the availability of neutralizing antibodies.

Carry out all procedures at laminar flow unless otherwise specified.

3.1 Biopanning Phage Libraries on Solid Apparatus

Panning procedure can be made outside laminar flow.

1. Prepare a solution of the target antibody at the concentration of 100 $\mu\text{g}/\text{mL}$ with coating buffer. Add 150 μL of this solution in a well of a microtitration plate for 18 h at 4 °C.
2. Discard the adsorption solutions. Wash the well two times with 250 μL of washing solution.
3. Block the well with 250 μL of blocking solution for 1 h at 37 °C. Wash the well two times with 250 μL of washing solution.
4. Add the PhD-12 or PhD-C7C phage library for selection of peptide sequences. Diluted 10 μL (4.0×10^{10} pfu) to 100 μL of TBS and add to the well of microtiter plate. Incubate for 1 h at 37 °C. Wash the well ten times with 250 μL of washing solution for the unbound phage particles discard.
5. Elute phages bound to the target with 150 μL of elution buffer for 10 min under agitation at room temperature. Transfer the eluate to microtubes and add 15 μL of neutralization buffer.

3.2 Amplification and Purification of Phage Eluate on *E. coli*

1. Add a colony of *E. coli* ER2738 in a 20 mL LB medium with 20 μL of tetracycline (*see Note 1*). Incubate at 37 °C under agitation until OD_{600} of 0.3. Add 150 μL of eluted and incubate for 5 h at 37 °C under agitation.
2. Transfer the medium to a centrifuge tube. Centrifuge for 10 min at $9600 \times g$ at 4 °C. Transfer the supernatant to another centrifuge tube. Add 1/6 of the total volume of the supernatant of PEG/NaCl. Incubate 16 h at 4 °C for phages precipitation.
3. Centrifuge the volume at $9600 \times g$ for 15 min at 4 °C. Discard the supernatant. Dissolve the pellet with 1 mL of PBS and transfer to a microtube. Add 1/6 of the total volume of the supernatant of PEG/NaCl. Incubate on ice for 1 h.

4. Centrifuge at $18,000 \times g$ for 10 min at 4 °C. Discard the supernatant and resuspend the pellet in 200 μ L of PBS. The amplified eluate can be used in other round of selection.

3.3 Titration of Phage Eluates

Two to five selection cycles can be performed for the enrichment of selected phage-fused peptides (*see Note 2*). The phage titration is used to disclose if the phage library was enriched and must be made with the amplified and non-amplified eluates (*see Note 4*). Library titration result must decrease as selection evolves, indicating that the library is increasingly specific to the selection target.

1. Inoculate a single colony of *E. coli* ER2738 in a 10 mL LB medium with 10 μ L of tetracycline (*see Note 1*). Incubate at 37 °C under agitation until OD₆₀₀ of 0.5.
2. Distribute 3 mL of LB top agar to each 15 mL Falcon tube, and maintain them at 50 °C to prevent polymerization.
3. Identify the microtubes according to the phage dilution (for non-amplified eluate 10^{-1} , 10^{-2} , 10^{-3} , and 10^{-4} ; for amplified eluate 10^{-1} , 10^{-2} , 10^{-3} , 10^{-4} , 10^{-5} , 10^{-6} , 10^{-7} , 10^{-8} , 10^{-9} , and 10^{-10}). Distribute 9 μ L of LB medium in each microtube. Dilute 1 μ L of the eluate at the first tube, then transfer 1 μ L of the mixture to the next tube, and so forth. In the last tube, discard 1 μ L.
4. Add 200 μ L of the *E. coli* at OD₆₀₀ of 0.5, mix, and incubate at room temperature for 5 min.
5. Transfer this mixture to the Falcon tubes with LB top agar. Mix quickly and shed to LB agar plates with IPTG/X-Gal (*see Note 3*). Incubate at 37 °C overnight.

3.4 Individual Clone Amplification and Purification

1. Inoculate a single colony of *E. coli* ER2738 in a 100 mL LB medium with 100 μ L of tetracycline (*see Note 1*). Incubate at 37 °C under agitation until OD₆₀₀ of 0.3.
2. Transfer the culture to a 96-deepwell plate (1 mL per well). Pick a blue colony from the last round of non-amplified phage titration (*see Note 5*) and put in a separated well. Do it until all wells of the plate are filled. Cover the plate with an adhesive plate sealer and make a hole with a needle in each well. Shake vigorously (at least 200 rpm) overnight at 37 °C (*see Note 6*).
3. Centrifuge at $1944 \times g$ for 15 min at 4 °C. Transfer 80 % of the supernatant to another deepwell. Add 1/6 of the total volume of the supernatant of PEG/NaCl. Incubate at 4 °C overnight.
4. Centrifuge at $1944 \times g$ for 60 min. Discard the supernatant and resuspend the pellet in 200 μ L of PBS. Mix by vortex.

3.5 Phage Spectrophotometric Quantification

1. Estimate the phage titer in plaque forming units (pfu) for the M13 virus by spectrophotometric quantification. Measure the samples at A_{269} and A_{320} . For calculating the virion concentra-

tion, use the following equation, wherein 6407 is the number of nucleotides in the M13 genome:

$$\text{Phages particles per ml} = \frac{(\text{measure } A_{269} - \text{measure } A_{320}) \times (6 \times 10^{16})}{6407}$$

3.6 Analysis of Selected Peptide by Supernatant Phage ELISA

Phage ELISA can be accomplished outside the laminar flow.

1. Coat a 96-well Maxisorp™ microtiter plate with 50 μL of a solution of the same target used in the selection in carbonate buffer (1 mg/well). Incubate overnight at 4 °C. Remove the supernatant and wash the plate twice with 250 μL of washing solution.
2. Add 250 μL of blocking solution and incubate for 1 h at 37 °C. Wash the plate twice with 250 μL of washing solution.
3. Add 50 μL of the culture supernatant containing amplified phage particles, before adding PEG/NaCl, and incubate 1 h at 37 °C (*see Note 7*). Wash the plate four times with 250 μL of washing solution.
4. For detection, add 50 μL of HRP-conjugated anti-M13 antibody diluted at 1:5000 in blocking solution. Incubate 1 h at 37 °C. Wash the plate four additional times.
5. For signal development, add 50 μL of an OPD-containing solution, and stop the reaction by adding 20 μL of 4 M H₂SO₄ after production of a yellow-orange reaction, and detect it by an ELISA microplate reader at 492 nm.

3.7 Phage DNA Isolation

Phage DNA isolation and sequencing must be performed for selected clones that reacted positively in the phage ELISA, as follows:

1. Inoculate a colony of *E. coli* ER2738 in a 100 mL LB medium with 100 μL of tetracycline (*see Note 1*). Incubate at 37 °C under agitation until OD₆₀₀ of 0.3.
2. Transfer the culture to a 96-deepwell plate (1 mL per well). Add 10 μL of phage solution. Cover the plate with an adhesive plate sealer and make a hole with a needle in each well. Shake vigorously (at least 200 rpm) overnight at 37 °C.
3. Centrifuge at 1944 × *g* for 10 min at 4 °C. Transfer 80 % of the supernatant to another deepwell. Add 1/6 of the total volume of the supernatant of PEG/NaCl. Incubate 10 min (maximum 20 min).
4. Centrifuge at 1944 × *g* for 10 min at 20 °C. Remove the supernatant and invert the plate on absorbent paper to getting dry.
5. Resuspend the pellet in 100 μL of iodide buffer using a vortex. Add 250 μL of absolute ethanol. Incubate 10 min at room temperature.

6. Centrifuge at $1944 \times g$ for 40 min at 20 °C. Remove the supernatant. Add 150 μ L of 70 % ethanol.
7. Centrifuge at $1944 \times g$ for 10 min at 20 °C. Remove the supernatant. Place inverted plate on paper towel into centrifuge and spin. Resuspend the pellet in 20 μ L of distilled water.
8. Evaluate the quality of the DNA in a 1 % agarose gel electrophoresis.

3.8 Viral DNA Sequencing and Bioinformatics Analysis

1. After isolating the phagemid DNA, carry out the automatic sequencing as available sequencer manufacturer's standards. For the PCR reaction of each selected phage clone, use 2–4 μ L of isolated DNA, 5 pmol of the primer -96 gIII (5'-CCC TCA TAG TTA GCG TAA CG-3') and the premix suggested by the sequencer manufacturer.
2. Perform 35 cycles in a thermocycler, under the following conditions: denaturation at 95 °C for 20 s, annealing at 58 °C for 15 s, and extension at 60 °C for 60 s.
3. Deduce peptide sequences of the valid phage clones using the ExPASy server (www.expasy.org).
4. Use BLAST search (<http://blast.ncbi.nlm.nih.gov/Blast.cgi>) to search for similarities of selected peptides with proteins of the target organism.
5. Sequence alignments among phage clones can also be done by using ClustalW2 software (<http://www.ebi.ac.uk/Tools/msa/clustalw2/>) to disclose common motifs among sequences. A graphical representation of the conserved sequence patterns within a multiple sequence alignment can be generated by using WebLogo3 (<http://weblogo.berkeley.edu/>) [7].
6. Three-dimensional structural alignments of the phage ligands with known protein targets with available PDB (<http://www.rcsb.org/>) files can be performed by using PyMOL (<http://www.pymol.org>) (*see Note 8*).

3.9 Phages Production in a Major Volume for Purified Phage ELISA

The clones that presented good reactivity in the ELISA with the supernatant of phages and that was selected by bioinformatics must be amplified in a major volume of culture medium and quantified for other tests. For these, use the protocol in Subheading 3.2 for phage amplification and purification. Then, proceed the ELISA based on Subheading 3.6. Instead of 50 μ L of phage supernatant, start with 1×10^{11} pfu (*see Note 9*), keeping the remaining of the ELISA protocol (*see Note 7*).

3.10 Use of the Best Selected Phage Clones as a Vaccine Target

Based on the highest reactivity values (ELISA assays) and bioinformatics analysis, phage clones can be chosen for the primary immunogenicity assessment in vivo (*see Note 10*).

Selected mimotopes by PD can be used in vaccine formulations as immunogens using either the direct phage-peptide clone or a synthetic mimotope [4].

3.10.1 Direct Use of Phage Clones as Immunogens

Phage clones can be mixed with adjuvant (saponin or Freund's adjuvant) in PBS or the phage can be used to immunize alone, because the phage itself has adjuvant properties [4, 6, 8].

1. Amplify, purify (Subheading 3.2), and quantify (Subheading 3.5) selected phage clones.
2. Mix 1×10^{11} cfu of the phage in PBS, with or without adjuvant, in a total volume of 100 μ L. To use adjuvant, mix 50 μ L of the adjuvant with 50 μ L of phage in PBS, and agitate vigorously (vortex) until a white emulsion is formed (*see Note 11*).
3. Before the first immunization cycle, collect about 200 μ L of blood from the tail vein of the mice for obtain the pre-immune serum.
4. For 6-week female BALB/c mice, vaccine with three intraperitoneal (or subcutaneous) injections at 15-day intervals with 100 μ L of phage and PBS mix (with or without adjuvant) (*see Note 12*).
5. Between each immunization cycle, collect about 200 μ L of blood from the tail vein for post-immunization follow-up by serological analyses.

3.10.2 Design of Synthetic Peptides as Immunogens and Vaccine Formulation

After phage clone selection, peptide sequence characterization, ELISA reactivity measurements, and bioinformatics' analyses, selected peptides must be synthesized for immunogenic tests. Peptides can be designed de novo or based on peptide sequences from native proteins, depending on the desired application. The design of synthetic immunogenic peptides can be improved through conjugation or modifications (acetylation, phosphorylation, amidation) or by using multiple or repeated motifs separated by spacers that aim conformational arrangements of original epitope structures. Virus capsid with multiple repeated protein subunits is an example of desired replication of multiple epitope motifs to mimic the original structure of the virus.

1. Repeating the peptide sequence or the immunogenic motif 2–4 times will mimic the phage capsid structure of the pIII protein. A short spacer sequence (Gly-Gly-Gly-Ser) may be used between peptide motifs, because this sequence is part of the peptide fusion to the pIII protein N-terminus of the M13 phage. Peptides alone are generally too small to elicit an immune response sufficient to generate antibodies; therefore, BSA conjugation to the sequence is also desired to enhance the immunogenic response. Evaluate the peptide purity using HPLC. Freeze-dry each synthetic peptide and store at -20 °C.

2. Mix 10 μg of synthetic peptide in PBS and adjuvant, in a total volume of 100 μL (50 μL of the adjuvant with 50 μL of the peptide in PBS). Vortex vigorously, until a white emulsion is obtained (*see Note 13*).
3. Before the first immunization cycle, collect about 200 μL of blood from the tail vein of the mice to obtain the pre-immune serum.
4. For 6-week female BALB/c mice, apply three intraperitoneal (or subcutaneous) injections at 15-day intervals with 100 μL of phage and PBS mix (with or without adjuvant) (*see Note 12*).
5. Between each cycle of immunization, collect about 200 μL of blood from the tail vein of the mice for post-immunization follow-up by serological analyses.

3.10.3 Challenge Infection

1. Four weeks after the last immunization, euthanize part of the group for analysis of the immune response elicited by vaccination (*see Note 14*).
2. Infect intraperitoneally (or subcutaneously) the remaining animals with the target parasite/pathogen.
3. Observe the animals daily for mortality, morbidity, and body weight changes (*see Note 15*).
4. Euthanize all surviving animals 10 weeks post-challenges, collecting blood and spleen for analysis of protection against challenge (*see Note 14*).

3.10.4 Analyses of Immunological Response in Mouse Model (See Note 16)

Cellular Response

1. Perform splenocyte cultures and cytokine assays before infection and at tenth week after challenge.
2. Macerate the spleen gently with 2 mL of incomplete medium. Homogenize cells by pipetting up and down and transfer the volume to a 15 mL Falcon tube. Centrifuge at $400\times g$ for 10 min at 4 $^{\circ}\text{C}$.
3. Resuspend the pellet with 2 mL of lysis buffer. Incubate at 37 $^{\circ}\text{C}$ for 5 min. Add incomplete medium to a 10-mL final volume. Centrifuge at $400\times g$ for 10 min at 4 $^{\circ}\text{C}$.
4. Wash one more time as done before for removal of all red blood cells.
5. Resuspend the pellet with 5 mL of incomplete medium or PBS. Add 5 μL of CFSE. Incubate for 5 min at room temperature. Add complete medium to a 10-mL final volume. Centrifuge at $400\times g$ for 10 min at 4 $^{\circ}\text{C}$.
6. Wash one more time using complete medium.
7. Resuspend the pellet with 10 mL of complete medium.
8. Count the cells using trypan blue and a Neubauer chamber. Set the dilution to 2×10^5 cells per 100 μL .

9. Plate in duplicate in 96-well plate the single-cell preparation from spleen tissue.
10. Add the stimuli (only medium, antigen, and Con A) (*see Note 17*). Incubate in 5 % CO₂ atm at 37 °C.
11. Determine the IFN- γ , IL-6, IL-10, TNF- α , and IL-12 levels in the culture supernatants and other cytokines as needed, using available commercial kits, according to manufacturers' instructions.

Humoral Response

An ideal vaccine formulation must generate both Th1 and Th2 responses. The presence of the IgG2 isotype in mice has been considered as an evidence of a Th1-type immune response, and the elevated production of IgG1 may be due to the antigen association with adjuvant, which may preferentially stimulate the Th2 response. Therefore, IgG, IgG1, and IgG2a antibodies can be measured by ELISA.

1. Coat a 96-well Maxisorp™ microtiter plate with 50 μ L of a solution of the same target used in the selection in carbonate buffer (1 μ g/well). Incubate overnight at 4 °C. Remove the supernatant and wash the plate twice with 250 μ L of washing solution.
2. Add 250 μ L of blocking solution and incubate for 1 h at 37 °C. Wash the plate twice with 250 μ L of washing solution.
3. Add 50 μ L of serum samples diluted 1:50 in blocking buffer and incubate at 37 °C for 1 h for IgG and for 2 h for IgG1 and IgG2a quantifications. Wash the plate six times with 250 μ L of washing solution.
4. Add 50 μ L of peroxidase-labeled goat anti-mouse IgG, IgG1, and IgG2a antibodies, diluted at 1:5000 in blocking solution. Incubate 1 h at 37 °C. Wash the plate six additional times.
5. Add peroxidase diluted at 1:1000 in blocking solution. Incubate 1 h at 37 °C. Wash the plate six additional times.
6. For reaction development, add 50 μ L of an OPD-containing solution. Stop the reaction by adding 20 μ L of 4 M H₂SO₄ after production of a yellow-orange reaction, and detect it by an ELISA microplate reader at 492 nm.

4 Notes

1. After autoclaving the medium, tetracycline must be added. When the medium reaches a bearable temperature for hand contact, add 1 μ L of antibiotic (15 μ g/mL) to each 1 mL of medium.
2. From the second cycle, the washing buffer stringency must be increase from 0.1 to 0.5 % with Tween 20 in all washes.
3. When you remove the LB agar medium of the autoclave and the medium reach a bearable temperature for hand contact,

add tetracycline, IPTG, and X-Gal, and then dispose the volume in Petri dishes.

4. Phage titration is used to set up the volume of the amplified phage that corresponds to 4.0×10^{10} pfu, which will be used in the next round of selection. Selection must be stopped when titration of non-amplified eluates is kept constant between selection cycles.
5. In the last round of selection, amplification of eluates is not needed anymore.
6. A backup of the individual clones is desired. After 5-h phage amplification, pipette 100 μ L of the amplified medium, transfer to a 96-well polystyrene microplate, and add 100 μ L of glycerol 50 % sterile. Return to the backup when a specific clone is needed.
7. M13 phage without displaying any exogenous peptide fused to the pIII protein, called wild type, may be used as negative control for non-bacteria targets. Unspecific peptide clones (irrelevant) are generally used as negative controls. The selected clone reactivity to the target must be higher than controls. In that case, reactivity of negative controls is used to determine the cutoff value.
8. Other bioinformatics tools can be used for the *in silico* analysis.
9. The quantity of phage used in the ELISA must be standardized.
10. No animal research may be carried out without the approval of the responsible animal experimentation ethics committee.
11. M13 phage may be used as a control group depending on the target pathogen/parasite. This fact must be considered relevant, once the own phage particles present proteins that can interact with the host immune system, leading to the development of an unspecific immune response, and interfering with the specific immune response induced by selected phage-displayed mimotopes [4]. Other control groups must be included, such as an irrelevant peptide, adjuvant alone, and PBS alone.
12. In this section, we have suggested BALB/c mice as the animal model, but sex, age, immunization route, and type of adjuvant must be chosen based on the disease target.
13. Inoculate only adjuvant, PBS and BSA (because it is coupled to the synthetic peptide), working as control groups.
14. Remove their spleens aseptically and stored for splenocyte culture.
15. Monitoring time varies according to the infection model.
16. Besides the humoral and cellular response, one can also estimate the parasite/pathogen load.
17. Concanavalin A is a mitosis inducer, working as a positive control.

Acknowledgements

This work has been supported by Brazilian funding agencies CNPq, CAPES, FAPEMIG, and FINEP.

References

1. Smith GP (1985) Filamentous fusion phage: novel expression vectors that display cloned antigens on the virion surface. *Science* 228:1315–1317
2. Smith GP, Scott JK (1993) Libraries of peptides and proteins displayed on filamentous phage. *Methods Enzymol* 217:228–257
3. Smith PG, Petrenko VA (1997) Phage display. *Chem Rev* 97:391–410
4. Prudencio CR, Marra AOM, Cardoso R, Goulart LR (2010) Recombinant peptides as new immunogens for the control of the bovine tick, *Rhipicephalus (Boophilus) microplus*. *Vet Parasitol* 172:122–131
5. Santos PS, Sena AAS, Nascimento R, Araujo TG et al (2013) Epitope-based vaccines with the *Anaplasma marginale* MSP1a functional motif induce a balanced humoral and cellular immune response in mice. *PLoS One* 8(4): e60311
6. Costa LE, Goulart LR, Pereira NCJ, Lima MIS, Duarte MC et al (2014) Mimotope-based vaccines of *Leishmania infantum* antigens and their protective efficacy against visceral leishmaniasis. *PLoS One* 9(10):e110014
7. Crooks GE, Hon G, Chandonia JM, Brenner SE (2004) WebLogo: a sequence logo generator. *Genome Res* 14:1188–1190
8. Barbas CF, Burton DR, Scott JK, Silverman GJ (2001) Phage display: a laboratory manual. Cold Spring Harbor Laboratory Press, Cold Spring Harbor, NY

Chapter 29

Production of Well-Characterized Virus-like Particles in an *Escherichia coli*-Based Expression Platform for Preclinical Vaccine Assessments

Newton Wahome, Anne Cooper, Prem Thapa, Shyamal Choudhari, Fei P. Gao, David B. Volkin, and C. Russell Middaugh

1 Introduction

Virus-like particles (VLPs) consist of subunit viral capsid proteins that self-assemble into an enclosed core-shell morphology. These subunits are highly symmetrical, leading to the spontaneous formation of spherical particle-like structures. This structure mimics viruses in nature, which often use symmetry principles to minimize the energy required to synthesize multiple variants of the core building block [1]. The use of VLPs as vaccine candidates takes advantage of viral capsid protein building blocks to form higher-order oligomeric species, which have been shown to be highly immunogenic, especially in relation to their corresponding non-oligomeric proteins [2, 3]. This enhanced *in vivo* immunogenicity is thought to be the result of organisms having evolved to recognize the repetitive display of antigens on the surface arrays of pathogens such as viruses and bacteria [4]. It has been proposed that systematic or crystalline display of these antigens promotes the cross-linking of B-cell receptors, which enhance signaling across the cell membrane [5]. VLPs maintain this repetitive antigen display and, at the same time, are considered safer as potential vaccine candidates compared to traditional live, attenuated or inactivated viruses, since they do not contain a genome that can be replicated. The success of this approach is well illustrated by the worldwide commercial availability of the hepatitis B and human papillomavirus VLP-based vaccines which protect against cancers, as well as the infections themselves [6–8]. Recently, a hepatitis E VLP-based vaccine was approved for use in China, and numerous VLP vaccine

candidates to protect against a variety of infectious agents are in clinical development [9].

VLPs can be produced from a single capsid unit or may require multiple components for successful assembly including additional viral proteins and/or a lipid envelope. The level of assembly complexity determines which cell expression system is most applicable [10, 11]. For example, *Escherichia coli* (*E. coli*) [12, 13] and yeast cells (such as *Saccharomyces cerevisiae* and *Pichia pastoris*) can be used for the expression of single subunit, non-enveloped particles [14]. For example, the human papillomavirus VLP vaccine consists of 72 pentamers of the L1 protein [15]. Yeast cells are also used to produce single capsid subunit, enveloped VLPs. The best-known example of this type of VLP is the hepatitis B VLP vaccine consisting of surface antigen (sAg) protein embedded in a lipid envelope derived from the host cell [7]. Yeast cells can facilitate limited post-translational modifications such as N-linked glycosylation to aid in assembly [16]. Baculovirus–insect cells can be used to assemble either single or multiple subunit VLPs and to perform simple post-translational modifications [17]. Other eukaryotic cells, such as various plant and mammalian cell expression systems [18], can produce enveloped VLPs by incorporating the lipid membrane in the assembly process. Mammalian cells have the advantage of maintaining the most native posttranslational modifications while limiting the presence of contamination from nonmammalian sources (e.g., baculovirus) [19]. However, mammalian cells might yield less protein and have a higher operational cost than other expression platforms.

Commercial VLP production has been achieved with *Escherichia coli*, yeast, baculovirus–insect cell, and CHO mammalian cell expression systems. HBsAg VLPs produced in yeast (*Saccharomyces cerevisiae* and *Pichia pastoris*) or CHO mammalian cells, HPV VLPs expressed in *S. cerevisiae* (Gardasil 1, Merck & Co.) or in insect cells (Cervarix 1, GlaxoSmithKline), and hepatitis E virus (HEV) VLPs expressed in *E. coli* and assembled in vitro (Hecolin1, Xiamen Innovax Biotech Co. Ltd.) are the only licensed VLP-based human vaccines (Fig. 1). Numerous VLP-based vaccine candidates are currently in clinical trials and are produced using various expression systems [11].

In this protocol, we will focus on the *E. coli* expression platform. It is an inexpensive means for the production of VLPs that are derived from non-enveloped viruses or de novo designed fusion proteins [20]. While this platform limits the types of VLPs that can be expressed as well as the nature of posttranslational modifications, the *E. coli* platform is a system that small- to medium-sized laboratories can handle with ease. The advantages include short turnaround times from transformation to expression of proteins (24–48 h), the low cost of the nutrient media, the relatively high yield of protein (once a culture expression protocol has been



Fig. 1 (a). Agarose gel confirming molecular weight and purity of lumazine synthase (*B. anthracis*) PCR product. **(b)** Insertion of lumazine synthase sequence (*lower case*) into the pTBSG vector (*upper case*) is verified by T7 and T7-ter sequencing primers. The *red* regions indicate restriction digestion sites (NdeI and BamHI for this study)

optimized and if the protein is not toxic to the *E. coli* strain), the ubiquity of vector platforms due to their common use, and the ease of maintenance of cell stocks by freezing at -80°C .

The specific *E. coli* expressed VLP scaffold we will discuss here is based on the lumazine synthase enzyme, which is responsible for the synthesis of a riboflavin (vitamin B2) precursor, and is present in most pathogenic bacteria. Lumazine synthase exists naturally as an oligomer, either as a pentamer, a decamer, or an icosahedron depending on the species, and assumes a highly conserved $\alpha\beta$ fold [21]. Previously, the decameric form from a *Brucella* species has been prepared as a vaccine presentation system for the display of the pentameric B subunit from Shiga toxin of enterohemorrhagic *Escherichia coli* (EHEC), conferring protection in a mouse model [22]. Similarly, the icosahedral lumazine synthase of the thermophile, *Aquifex aeolicus*, has been used for the presentation of the GP120 HIV surface protein [23]. The lumazine synthase described here is from *Bacillus anthracis* [24]; the protein contains 153 amino acids which in turn forms an icosahedral assembly.

2 Materials

2.1 Cloning, Ligation, Transformation, and Protein Expression

1. Plasmid DNA expression vector (pTBSG) as described in detail elsewhere [25].
2. DNA insert sequence encoding 153 amino acids from lumazine synthase present in *Bacillus anthracis* as described in detail elsewhere [24]:

MVFEGLHLVGTGLKVGVVVGRFNEFITSKLL
 GGALDGLKRHGVEENDIDVAWVPGAFFIPLIAK
 KMANSWKYDAVITLGTVIRGATTHYDYVCNEVA
 KGVASL-SLQTDIPVIFGVLTTEIEQAIE-
 RAGTKAGNKGYESAVAAIEMAHLKHW.

In this study, we describe the use of lumazine synthase as a naked VLP scaffold [24]. The VLP can be designed as a fusion protein presenting a covalently linked antigen on its surface. For example, the subunit coding for the trimeric domain from gp120 can be linked to this sequence with a glycine/serine linker [23]. If the VLP scaffold is the immunogenic domain, no fusion proteins are necessary (hepatitis B, human papillomavirus, etc.).

The following reagents and supplies are required:

3. High-fidelity DNA polymerase and buffer such as PfuUltra II HS DNA polymerase and 10× PfuUltra II reaction buffer (Agilent Technologies, Palo Alto, CA, USA).
4. 10 mM dNTP mixture containing 10 mM each of dATP, dTTP, dCTP, and dGTP in nuclease-free water (Agilent Technologies, Palo Alto, CA, USA).
5. Insert specific primers for PCR diluted to 10 μM each, in either nuclease-free water or 1× TE (pH 8.0) (GenScript USA Inc., Piscataway, NJ, USA).
6. Dimethyl sulfoxide (DMSO) (Fisher Scientific, USA).
7. Luria Broth (LB) medium: 10 g of tryptone, 5 g of yeast extract, and 10 g of NaCl. Add ultrapure water to 1 L, and autoclave in a 5 L flask (to maintain at least 30–50 % head space) (Becton, Dickinson (BD) and Company, Franklin Lakes, NJ, USA).
8. Terrific Broth (TB) medium: 24 g of yeast extract, 12 g of tryptone, and 4 mL of glycerol. Add ultrapure water to fill the volume to 900 mL and autoclave in 5 L flask. After the TB medium has cooled, add 100 mL of autoclaved TB salts, containing 23.1 g of KH₂PO₄ and 125.3 g of K₂HPO₄ (BD, Franklin Lakes, NJ, USA).
9. Agar plate made of LB broth and agar (2.5 %) (BD, Franklin Lakes, NJ, USA). Mix the LB/agar/water and autoclave, wait until it cools to ~50 °C, and add filter-sterilized antibiotics. Pour the plates (~20–25 mL per dish).
10. Chemically competent *E. coli* cells suitable for high-efficiency transformation such as NEB 5-alpha F'Iq Competent *E. coli* (New England Biolabs, Ipswich, MA, USA).
11. Chemically competent *E. coli* cell suitable for transformation and protein expression such as BL21(DE3)pLysS competent cells (Promega, Madison, WI, USA).

12. Antibiotics: 100 $\mu\text{g}/\text{mL}$ of ampicillin in water and sterile filtered (0.2 μM filter) and 34 $\mu\text{g}/\text{mL}$ of chloramphenicol in 100 % ethanol and sterile filtered (0.2 μM filter) (Gold Biotechnology, St. Louis, MO, USA).
13. Isopropyl β -D-1-thiogalactopyranoside (IPTG) (Gold Biotechnology, St. Louis, MO, USA).
14. Agarose gel electrophoresis reagents: 1 \times Tris–acetate–EDTA (TAE) buffer, 0.8 % agarose gel (reagents from Bio-Rad, Hercules, CA, USA), and 0.2 g/mL ethidium bromide (Sigma Aldrich, USA).
15. Agarose gel electrophoresis instruments: PowerPac 3000 power supply, Mini-Sub cell chamber (Bio-Rad, Hercules, CA, USA).

2.2 Protein Purification and Characterization

1. HiTrap Q FF resin (Q-sepharose), 5 mL, ion-exchange affinity column (GE Healthcare, USA).
2. Superose 6 10/300 GL resin, size-exclusion column (GE Healthcare, USA). Total column volume, 24 mL; MW separation range, 5000–5,000,000 Da.
3. Buffers for purification: potassium phosphate buffer (20 mM, 100 mM, 1 M), pH 8.0.
4. Quartz cuvettes (Starna Cells, Atascadero, CA, USA).
5. Formvar/carbon grids for electron microscopy (Electron Microscopy Sciences, Hatfield, NJ, USA).
6. Bicinchoninic acid assay kit for protein quantification (Sigma Aldrich, USA).
7. 550 Sonic Dismembrator (Fisher Scientific, Hampton, NH, USA).
8. To prepare eight gels for SDS–PAGE gel electrophoresis using standard hand casting techniques: (a) For 15 mL of a 5 % stacking gel, add 250 μL of ammonium persulfate (APS), 150 μL of 10 % sodium dodecyl sulfate (SDS), 30 μL of tetramethylethylenediamine (TEMED), 3 mL of acrylamide, 3.75 mL of 0.5 M Tris (pH 6.8), 8.55 mL of ultrafiltered H_2O . (b) For 40 mL of a 12 % gel, add 600 μL of APS, 400 μL of 10 % SDS, 52 μL of TEMED, 16 mL of acrylamide, 10 mL of 1.5 M Tris (pH 8.8), 13.4 mL of ultrafiltered H_2O (SDS–PAGE reagents from Bio-Rad, Hercules, CA, USA).
9. SDS–PAGE gel casting chambers, Mini-PROTEAN[®] Tetra cell electrophoresis chamber, and PowerPac 300 power supply (SDS–PAGE instruments from Bio-RAD, Hercules, CA, USA).
10. SimplyBlue[™] Safe Stain (Coomassie) (Life Technologies, USA).

2.3 Instrumentation

1. PCR thermocycler: Mastercycler pro (Eppendorf, Hauppauge, NY, USA).
2. UV-visible diode array spectrophotometer: Agilent 8453 (Agilent Technologies, Palo Alto, CA, USA) equipped with a Peltier temperature controller device.
3. ZetaPALS zeta potential analyzer (Brookhaven Instrument Corp., Holtzville, NY, USA) equipped with a 50 mW helium-neon laser operating at 532 nm.
4. FEI Tecnai F20 XT field emission transmission electron microscope (TEM) 200 kV electron source (FEI, Hillsboro, OR, USA).
5. AKTA purification FPLC (GE Healthcare, USA).
6. EMS Quorum 150T ES (Quorum Technologies Ltd, East Sussex, UK).

3 Methods

3.1 Cloning, Ligation, and Transformation

The protein subunit is produced in *E. coli* by expression from the plasmid DNA vector in which the target sequence has been inserted. These plasmid inserts can either be amplified as PCR products from the genome of the pathogens of interest, from another plasmid, or synthesized by a commercial source for insertion into a plasmid expression vector [26]. Artificial synthesis of the insert is a more cost-effective approach if cells infected by or from pathogens are not readily available, either due to lack of access or lack of appropriate biological safety containment protocols, and/or if no other plasmids are currently available. Factors to consider while designing an insert include its size and complexity. Codon optimization might also be necessary if the insert contains codons that are rare in *E. coli*. Most commercial sources have freely available software to optimize nucleic acid sequences for the desired expression host (e.g., *E. coli*). During ligation, attaining an optimal molar ratio for successful cloning may require testing different relative concentrations of insert and vector. Occasionally, some expressed proteins are also toxic to particular strains of *E. coli*, which can cause cloning problems if the plasmid vector has some baseline expression level. Strategies for reducing toxicity include varying the vectors and *E. coli* strains and altering incubation times and temperatures for the cells.

To transform ligated insert into *E. coli* cells, the following protocol is utilized:

1. Lumazine synthase insert is synthesized by a commercial source (Integrated DNA Technologies, Inc., Coralville, IA, USA) and PCR amplified upon receipt by combining nuclease-free water to 50 μL with 5 μL 10 \times PfuUltra buffer, 1.25 μL 10 mM dNTP mix, 1 μL each primer, 10 ng template DNA containing

insert of interest, 1.5 μL DMSO, and 1 μL PfuUltra II fusion HS DNA polymerase in a thin-walled 200 μL PCR tube. The following PCR amplification cycle for the reaction mix is used: (1) 1 cycle at 95 $^{\circ}\text{C}$ for 2 min; (2) 30 cycles at 95 $^{\circ}\text{C}$ for 30 s, 55 $^{\circ}\text{C}$ for 30 s, and 72 $^{\circ}\text{C}$ for 1 min; (3) 1 cycle at 72 $^{\circ}\text{C}$ for 5 min; (4) last cycle kept at 4 $^{\circ}\text{C}$. The size and purity of the PCR product can be verified by agarose gel electrophoresis and staining with ethidium bromide (Fig. 1a).

2. The PCR product and vector are digested by restriction enzymes, such as NdeI and BamHI. In this study, the pTBSG vector was used, and the histidine-tag, TEV-cleavage site, and linkers were removed during restriction digestion. A tag-free plasmid, for example, pET9a, may be preferable for ease of use (*see Note 1*).
3. After digestion, standard gel electrophoresis is used to separate the two fragments of the vector based on size. The fragment of interest (typically the larger band) can be extracted from the agarose gel with commercially available kits. An EZNA gel extraction kit (Omega Bio-Tek, Norcross, GA, USA) was used to obtain the linearized pTBSG vector. Linearized vectors are then dephosphorylated using a phosphatase enzyme. We use FastAP Thermosensitive Alkaline Phosphatase (Life Technologies, USA) as per manufacturer's instructions to help prevent re-circularization of the vector during ligation. An EZNA cycle pure kit (Omega Bio-Tek, Norcross, GA, USA) was used to purify the lumazine synthase insert PCR product. If the insert was amplified from a template plasmid, the PCR product should be gel-extracted as the vector. This ensures that the template plasmid is not present in the purified product.
4. The purified insert and vector are then ligated using a Rapid DNA Ligation Kit (Life Technologies, Carlsbad, CA, USA) as per manufacturer's instructions. 2 μL of the ligated product was transformed into high-efficiency NEB 5-alpha F'I⁺ competent cells (New England Biolabs, Ipswich, MA, USA) as per the manufacturer's directions, and half of the transformation reaction was plated onto pre-warmed (37 $^{\circ}\text{C}$) LB agar plates containing 100 $\mu\text{g}/\text{mL}$ ampicillin and grown at 37 $^{\circ}\text{C}$ overnight.
5. Single colonies were picked and grown in 3 mL LB media with 100 $\mu\text{g}/\text{mL}$ of ampicillin overnight at 37 $^{\circ}\text{C}$. Overnight cultures are mini-preped using an EZNA mini-prep kit (Omega Bio-Tek, Norcross, GA, USA), and a 2 μL aliquot of mini-preped plasmid DNA should be digested with restriction enzymes, e.g., NdeI and BamHI. Gel electrophoresis is used to verify the presence of insert in the vector.
6. Plasmids containing insert should be verified by sequencing to be certain that they are in frame with the desired start and stop

codons and that no spurious mutations occurred. For the vector pTBSG, T7 and T7-ter sequencing primers (Fig. 1b) can be used. Other vectors may need different sequencing primers.

7. Sequence-verified plasmid is transformed into BL21(DE3) pLysS expression cells (Promega, Madison, WI, USA) as per manufacturer's recommendations (standard heat-shock transformation, 42 °C for 30 s). Add 250 µL of the SOC media (without antibiotic) and grow at 37 °C shaking at 200 rpm for an hour. This overgrowth step is not critical for ampicillin-resistant plasmids. Half of the transformation reaction is plated on LB agar plates containing 100 µg/mL ampicillin and 34 µg/mL chloramphenicol. Transformation protocols and antibiotics should be based on expression cell line and plasmid resistance. Single colonies are picked from the plate and grown in 3 mL LB media with 100 µg/mL ampicillin and 34 µg/mL chloramphenicol. These overnight cultures are used to make frozen cell stocks using glycerol as lyoprotectant. The stocks are frozen as a 1 mL culture, with 200 µL of PBS and glycerol at 1:1 ratio. An alternative freezing method can be performed by mixing 930 µL overnight culture with 70 µL DMSO in microcentrifuge tubes and storing immediately at -80 °C.

3.2 Protein Expression

To express VLPs in *E. coli* cells, the following steps are followed:

1. Pick a colony from the transformation LB agar plate (Fig. 2). Transfer it, using aseptic practices, to a sterile test tube

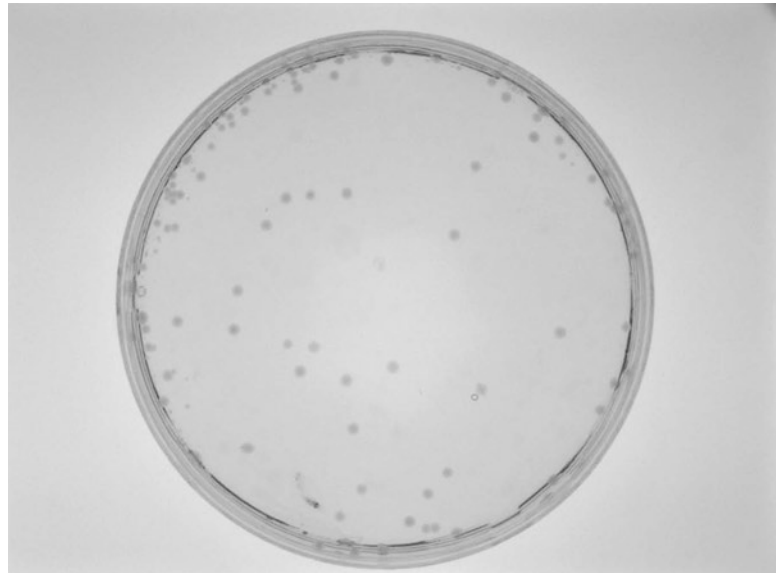

Fig. 2 LB agar plate containing the transformed *E. coli* competent cell colonies, for the expression of lumazine synthase VLPs. The cells should be plated with appropriate antibiotics

containing 10 mL of LB medium and antibiotic (100 $\mu\text{g}/\text{mL}$ of ampicillin and 34 $\mu\text{g}/\text{mL}$ of chloramphenicol). Place the tube in a shaker (200 rpm), and grow overnight at 37 °C. This step will provide the starter culture stock for higher volume expression.

2. Add 100 $\mu\text{g}/\text{mL}$ of ampicillin and 34 $\mu\text{g}/\text{mL}$ of chloramphenicol to TB medium and inoculate with 1 mL of starter culture. Place the flask in a shaker (200 rpm), and grow the cells at 37 °C. With an absorption spectrophotometer, monitor the optical density (OD) at 600 nm (OD_{600}) every 30 min. When the OD_{600} is approximately 0.8, induce the cultures with isopropyl β -D-1-thiogalactopyranoside (IPTG) (0.3 mM final concentration). Transfer the flask to grow overnight at 18 °C, shaking at 200 rpm for 14–16 h (*see Note 2*).
3. After cell growth and induction, centrifuge the culture at $9000\times g$, 4 °C for 20 min. Discard the supernatant, and freeze the cell paste at -80 °C.

3.3 VLP Purification

Purification of the VLPs from cell paste can be performed with a combination of steps. First, a cell lysate is prepared and then filtered (0.45 μm filter) or centrifuged prior to loading on the column to prevent back pressure and clogging issues. Chromatography steps can now be used for main purification step, for example, an ion-exchange column can be used. This step removes contaminants based on charge distribution on the surface of the molecules (*see Note 3*). Metal affinity or hydrophobic interaction columns can be used instead of ion-exchange chromatography depending on the protein. The next polishing step, size-exclusion chromatography, is critical for separating the different VLP populations. VLPs can assemble into populations of various sizes, containing a combination of fully folded high MW species as well as misfolded lower-order populations. SEC columns with the capability to separate protein species in the megadalton range can isolate these different sized populations.

Several considerations are necessary to optimize VLP purification. The expression of large protein assemblies in *E. coli* may lead to their sequestration in inclusion bodies. This can inhibit the formation of VLPs. It might be necessary to perform *in vitro* refolding under denaturing conditions to extract the protein of interest from the inclusion body and then promote self-assembly. Denaturants such as 8 M urea can be used during the purification process, with self-assembly being performed by dropwise or stepwise refolding out of the denaturant (i.e., dilution or dialysis).

To purify VLPs from a cell paste by a combination of ion-exchange and size-exclusion chromatography, the following steps are used:

1. From 3 L of expression culture, resuspend an *E. coli* pellet in 100 mL of ice-cold extraction buffer (50 mM potassium phosphate, 10 mM EDTA, pH 8.0) until it is a homogeneous suspension. No bacterial fragments should be present after resuspension.
2. Ultrasonicate the cell suspension using a 550 Sonic Dismembrator, tuned at an output of 8 for approximately 5 min. Keep the suspension in a beaker on ice during ultrasonication to avoid heating of the sample. The lysate should appear grayish in color after complete sonication. The lysate can be clarified before loading on the Q column by employing centrifugation steps.
3. A 5 mL Q-sepharose column (GE Healthcare, USA) is then connected to an AKTA purifier FPLC (GE Healthcare, USA), monitoring the purification procedure by UV absorption of the protein at 280 nm, DNA at 260 nm, as well as solution pH and conductivity. Data are collected using Unicorn version 5.2 software.
4. Run at a flow rate of 3–5 mL/min, and maintain pressure below 0.5 psi. Equilibrate the column with six column volumes of buffer A (20 mM potassium phosphate, pH 8.0). Load the sample onto the column at 3 mL/min. Elute the sample with buffer B (1 M potassium phosphate, pH 8.0). Collect 9 mL fractions using a linear gradient targeting 100 % of buffer B over 90 CV.
5. Run SDS–PAGE of the ion-exchange fractions to determine which fractions contain the protein of interest which will be further purified with size-exclusion chromatography (SEC) (Fig. 3). In this run, fractions containing only monomer were pooled together and concentrated by ultrafiltration. The sample loading volume for SEC is low (250 μ L), so highly concentrated protein is required.
6. For size-exclusion chromatography, a 24 mL Superose column (GE Healthcare, USA), with a MW cutoff of 5 MDa is used.
7. Connect the column to the AKTA FPLC and equilibrate with six column volumes of SEC–buffer A (100 mM potassium phosphate, pH 8.0). Elute for 1.5 column volumes (isocratic elution) at a 0.5 mL/min flow rate and collect 1.5 mL fractions (Fig. 4).
8. Concentrate the fractions by ultrafiltration for subsequent analysis by UV–visible absorption spectroscopy, dynamic light scattering (DLS), and transmission electron microscopy (TEM).

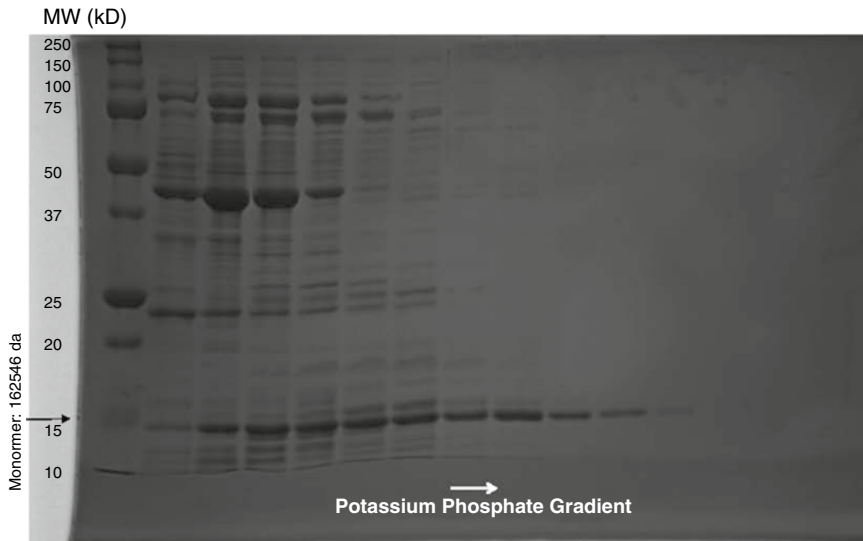

Fig. 3 SimplyBlue™ SafeStain (Coomassie) stained SDS–PAGE gel image analysis of fractions collected from an ion-exchange chromatography run. The lumazine synthase VLP is dissociated down to its monomeric components under SDS-denaturing conditions, to aid in visualization. The fractions become more pure as the concentration of potassium phosphate is increased (20–1000 mM). Some of the higher molecular weight bands in the earlier fractions (*left* side of gel) might be higher-order oligomers of the monomeric subunit

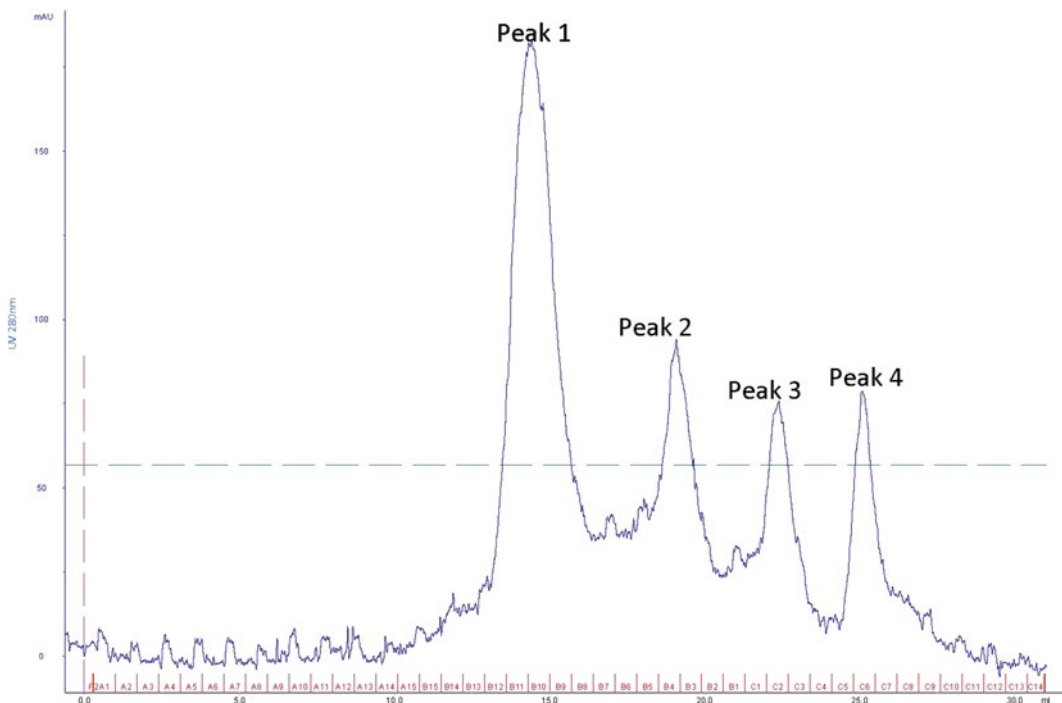

Fig. 4 Size-exclusion chromatography (SEC) of the purified ion-exchange fractions of the lumazine synthase VLP. SEC results indicate that multiple molecular weight species are present in solution (four peaks in the case of lumazine synthase VLPs). The SEC fractions (*red*) are monitored at an absorbance wavelength of 280 nm, to identify the quantity of protein. Molecular weight can be ascertained from standards covering the lower mega-dalton size ranges (e.g., known viruses or viruslike particles)

3.4 VLP Analysis

3.4.1 Ultraviolet–Visible Spectroscopy

Molecules with aromatic residues absorb light in the near ultraviolet (UV) and visible regions of the electromagnetic spectrum. The absorption of light is linearly dependent on the concentration of the solute. By monitoring the absorbance intensity at specific wavelengths, the concentration of molecules can be obtained, if their extinction coefficient is known. The strength of the absorbance signal is dependent on the environment and accessibility of the chromophore. UV spectroscopy is used to quantify the amount of protein solute based on absorbance intensity and can measure shifts in conformation based on changes in the molecular environment of the aromatic species. The concentration of proteins can be measured by monitoring amino acids such as phenylalanine, tyrosine, and tryptophan, which absorb light in the 240–300 nm region [27, 28].

Most UV–visible spectrophotometers use deuterium lamps as a UV light source and tungsten-halogen lamps for the visible spectrum. The preferred spectrophotometers are diode array based, which simultaneously measure the entire UV and visible spectrum. Light transmitted from quartz cuvettes passes through a prism or monochromator that separates it into its respective spectral components, which are quantified by an array of diodes. Wavelength resolution can be as low as 0.01 nm, with appropriate data analysis. Diode array-based UV absorption spectroscopy is a sensitive, non-destructive method, with a high signal-to-noise ratio.

Quantifying the amount of protein in the VLP can be affected by encapsulated nucleic acids. VLPs are based on viral capsomers that are natively in contact with an internal nucleic acid genome; therefore, expression of the lone capsid protein(s) might lead to encapsidation of associated nucleic acid content of the host cell [29]. The presence of nucleic acid can be measured by looking at the relative ratio of the absorbance intensities at UV 280 nm (protein) and UV 260 nm (nucleic acid). The concentration of protein can be determined from the extinction coefficient of the subunit protein (Fig. 5a). A number of spectral artifacts can complicate analysis, including light scattering and absorption flattening. These artifacts require correction if present (see below) [30].

To determine the concentration of protein in viruslike particles by UV absorption spectroscopy, the following protocol is utilized:

1. The lamps need to be warmed up for at least 15 min to give reproducible spectra.
2. Make sure the quartz cuvettes are clean, rinsed with ultrapure water, and wiped with lens paper to reduce dust particles.
3. The buffer to be used in the experiment should be used as a blank for the spectrophotometer. If dialysis is being performed, it is better to use the dialysate as the blank.

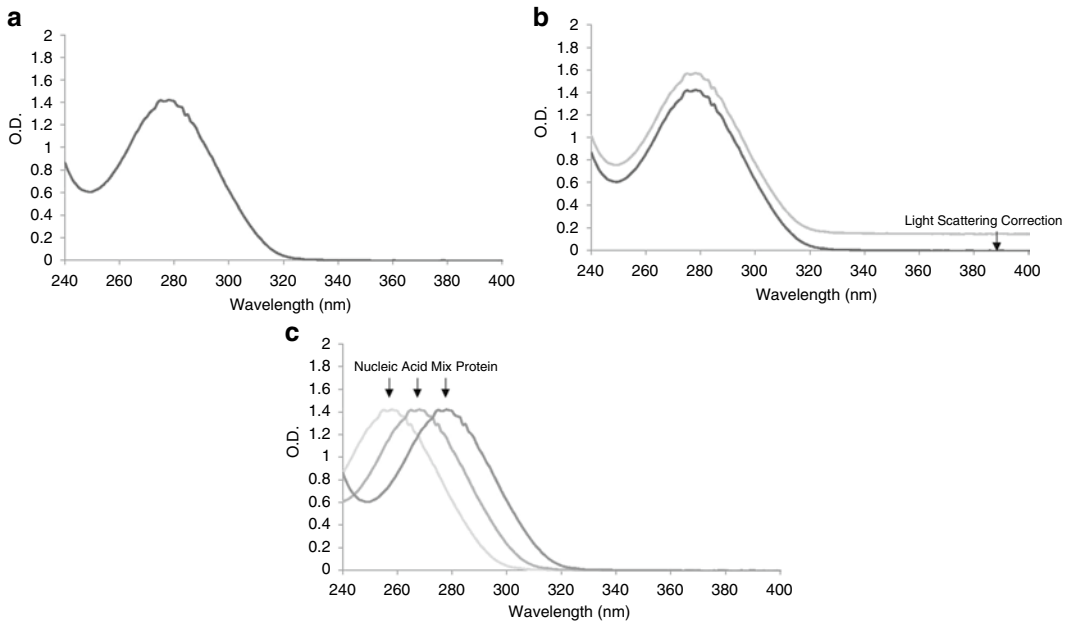

Fig. 5 (a) UV absorbance spectra of lumazine synthase protein. (b) Quantification of UV absorbance can be affected by light scattering in 320–400 nm region, due to the colloidal nature of a VLP suspension or turbidity (spectrum above). Light-scattering correction for the OD in the 320–400 nm range, providing a more accurate assessment of the UV absorbance (spectrum below). (c) Hypothetical VLPs showing a mixed nucleic acid and protein content. Zlotnick et al. look at the phenomena of VLP light scattering and nucleic acid contamination more extensively [29]

4. Depending on sample volume constraints, the path length of the quartz cuvette can be reduced, making sure to maintain protein concentration around 0.1–0.2 mg/mL. This maintains a high signal-to-noise ratio while being well below the saturation of most instruments (0.1–1 is a good working absorbance intensity range).
5. The colloidal nature of viruslike particles may create UV absorbance spectra with higher readings due to light scattering (Fig. 5b). Most instruments have light-scattering correction software that takes these effects into account, by extrapolating the OD in the 320–400 nm range through the UV absorbance region and subtracting it [30].
6. Determine the protein concentration using Beer–Lambert’s law (*see Note 4*).
7. To measure the content of nucleic acid in the sample (*see Fig. 5c and Note 5*), the ratio representing the relative maxima of nucleic acid to protein can be calculated, i.e., A_{260}/A_{280} . If the 260:280 ratio is 0.57, it indicates that solution has 100 % protein and no nucleic acid contamination.

3.4.2 Dynamic Light Scattering

Dynamic light scattering (DLS) calculates the rate of diffusion of species in a sample by analysis of their Brownian motion [31]. The size of solute particles affects their translational motion in solution, with larger molecules moving slower. When a coherent monochromatic visible light source interacts with particles in an aqueous solution, it leads to a small amount of light scattering. DLS measures the fluctuations of intensity of scattered light over time caused by the shift in distance between particles. An autocorrelation function is used to fit the time-dependent movement of the scattering particles.

The size distribution of the particles can be determined from the autocorrelation function of the scattered light over time. Measurements can be done at a single scattering angle, because most proteins are smaller than the wavelength of the scattered light thus the scattering intensity has little angular dependence. The size, shape, and heterogeneity of the particles in solution affect the accuracy of the DLS measurements. For monodisperse populations, a polynomial fit of the correlation function gives the distribution function of the decay rate. This is known as the cumulants' method [32]. Heterogeneous populations require polymodal analysis. Integration of a distribution of normalized decay rates, or regularization, can be used to measure a bimodal distribution of particles [33]. The particles need to have a significant difference in size for this approach to work.

In DLS, the Stokes–Einstein relationship [34] governs how the particle diameter affects the diffusion of spherical particles in the presence of incoming light, taking into account the viscosity of the medium, the temperature, and entropy of the system (Boltzmann's constant) (*see Note 6*). As most icosadeltahedral viruslike particles are quasi-spherical in nature [1], DLS is an ideal method for quantifying the mean diameter size of such oligomers. Heterogeneity in VLP populations can stem from variable self-assembly or aggregation [35]. Self-assembly of subunits into higher-order oligomers, with the same building block, can lead to populations of various sizes. The upper size limit of DLS is approximately 1 μm , so aggregation of proteins can significantly perturb the accuracy of the method. Large particles scatter more light than smaller ones, leading to significant inaccuracy.

To measure the size distribution of VLPs with DLS, the following protocol is used:

1. Clean the quartz cuvettes with ultrapure water, and wipe with lens paper to minimize dust particles.
2. To the cuvette, add a minimum volume of 300 μL to 1 mL of protein, based on the pathlength of the quartz cuvette, in order to detect below the meniscus of the liquid.
3. A good signal-to-noise ratio is dependent on the protein concentration, with the signal intensity being monitored via counts

in the thousands per second (KCPS), with a range of 50–200 KCP necessary to produce an adequate signal.

4. Turn on the instrument and laser and wait for at least 15 min for the laser to warm up before data collection.
5. Viscometers and refractometers can be used to get more accurate viscosity and refractive index values of the protein solutions being evaluated by DLS. Increasing the integration time and number of runs can also be used to obtain more reproducible data.
6. Latex beads covering the size range of the light scattering instrument, ranging from 2 nm to 1 μm , should be used to standardize and calibrate the instrument.
7. Measure the mean diameter and polydispersity of the virus-like particles at a concentration of 0.05–0.2 mg/mL. This should be done at least in triplicate. The lumazine synthase particles show a mean diameter of 15.7 nm and a polydispersity of 0.107, indicating a high level of sample homogeneity (Fig. 6a).

3.4.3 Transmission Electron Microscopy

Transmission electron microscopy (TEM) is an imaging technique in which a high-energy electron beam is transmitted through a thin specimen [36]. The transmission of the electron beam results in an enlarged image that can be used to obtain structural detail at the nanometer scale. The electron beam is generated by electron gun made of filaments such as lanthanum hexaboride (LaB6) and tungsten or by field emission guns [37]. TEMs operate under high vacuum pressure (10e^{-8} Pa), with the electrons being optically

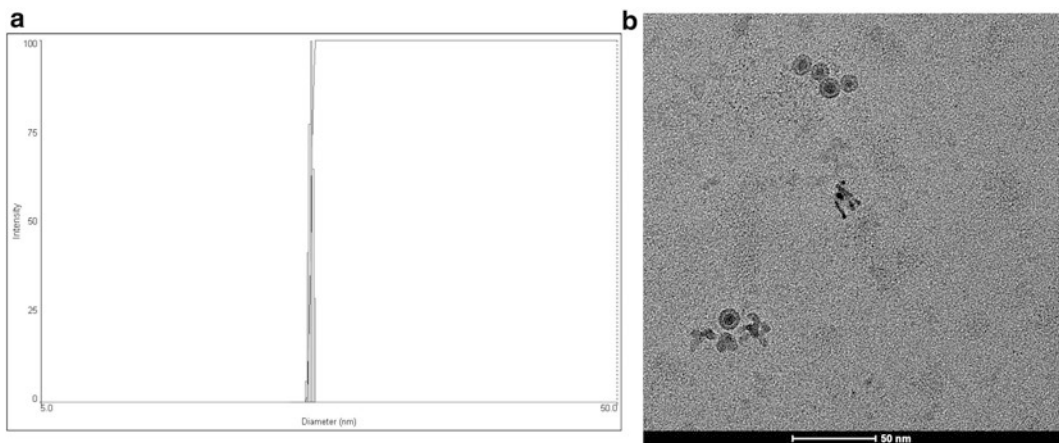

Fig. 6 (a) Dynamic light scattering (DLS) analysis of the lumazine synthase (*B. anthracis*) VLP. The spectra indicate a monodisperse solution of 15.7 nm sized particles, with a polydispersity of 0.107. (b) Electron micrographs from TEM analysis of lumazine synthase VLPs, indicating a core-shell morphology, with particles around 16 nm in size

focused by electromagnetic lenses and the image observed on a fluorescent screen or digital camera. The electrons are accelerated at several hundred kVs, giving wavelengths much smaller than that of light: 200 kV electrons have a wavelength of 0.025 Å and image resolution of less than 0.2 nm. The resolution of the TEM is affected by various factors. First, electrons cannot penetrate thick matter, so the specimen preparation will have to be as thin as possible. Second, spherical aberrations that occur during lens focusing can be compounded by chromatic aberrations from the energy spread of the electron beam [38]. TEMs that correct for spherical and chromatic aberrations are capable of picoscale resolution [39].

Sample preparation requires TEM specimens that are approximately 1000 Å or less in thickness, in the area of interest. Powder specimen can be directly dispersed on the carbon substrate of TEM grids, but some specimen needs to be ultra-thinned by focused ion beam (FIB) sectioning or ultramicrotome sectioning. Biological specimen contains light atoms (C, N, O) that do not provide sufficient contrast for electron microscopes. Staining with heavy atoms can help enhance contrast for these specimens. Negative staining, with heavy atom containing compounds such as uranyl acetate, has been commonly adapted for imaging of viruses and VLPs. Most VLPs are below 200 nm in diameter and are prepared in aqueous media that is directly pipetted on to thin carbon grids.

TEM facilitates the direct visualization of the morphology of the VLPs, permitting properties such as size and shape to be ascertained. The shape of the VLPs might help in determining how many subunit proteins are present in the complex and confirming whether proper self-assembly has occurred. The immunogenicity of the VLP might be affected if the secondary or tertiary structure of the protein is altered [15], which might also be indicated by any morphological aberrations (*see Note 7*).

To acquire a TEM image of VLPs, the following procedure is used:

1. Remove the formvar from carbon-coated copper grids, dip in fresh chloroform for 15 s, and air-dry. The removal of formvar helps to get higher-resolution images by transmitting more electron beam through the specimen.
2. The carbon support films tend to have a hydrophobic surface which inhibits the spreading of suspensions of particles in negative staining solutions. Therefore, the carbon grids are glow discharged for 30 s at 20 mA current with an EMS Quorum 150T ES leaving a hydrophilic and negatively charged surface, permitting easy spreading of aqueous suspensions.
3. Apply 6 µL of the VLPs on the glow-discharged carbon grids, wait for 1 min, blot the excess solution by wicking with a kimwipe, and leave to air-dry.

4. Each preparation is fixed by adding 1 % (v/v) glutaraldehyde (Sigma, USA) solution for 2 min by immersing the carbon-coated side of the grid onto a drop of glutaraldehyde solution suspended on parafilm, which is then immediately blotted dry using kimwipe.
5. The grids are then washed twice with ultrapure water, adding the water in the same manner as the glutaraldehyde.
6. The VLP preparations are negatively stained by adding 2 % uranyl acetate in ultrapure water for 1.5 min in the same manner as addition of the glutaraldehyde, wipe off the excess solution by kimwipe, and leave to air-dry.
7. Fill the electron microscope dewar with liquid nitrogen to condensate the moisture and contamination inside the chamber.
8. Place the grid on a single tilt specimen holder, check the status of the column valve (should be closed), and then insert the specimen holder into the electron microscope.
9. Open the column valve and center the electron beam by adjusting the X/Y position and the condenser stigmation knobs to get the electron beam and process the alignment protocols to maximize resolution.
10. Set up the eucentric height by minimizing the image movement with the change of the stage Z height. Eucentric height is important in TEM since it defines a reference point inside the microscope for all alignments, magnification, camera length, and so on. Therefore, one should always work at eucentric height.
11. Gun tilt/gun shift and beam tilt/beam shift should be well aligned using the alignment tools to maximize the image resolution.
12. Select an appropriate working voltage, gun lens, spot size, aperture, and magnification to get an appropriate image.
13. Collect images on various regions of the grids, at least in triplicate and at different magnifications, to get an adequate representation of the species present (Fig. 6b).

4 Notes

1. For VLPs, it is important to have the N- and C-terminus of the protein-free of affinity or cleavage-based residues (e.g., affinity tags, protease cleavage sites) since the oligomeric nature of the scaffold makes it difficult for complete removal of covalently linked amino acids by enzymatic digestion.
2. To optimize protein yield, it might be necessary to grow multiple colonies under different temperature and reagent

conditions. This may help increase the quantity of high-quality protein produced in larger scale or in fermenters. For vaccine use, considerations such as scale up of protein and final cell expression system should be taken into account as the small-scale production protocol is being established.

3. Purification by ion-exchange chromatography helps separate nucleic acid or protein contaminants. Endotoxin removal kits can be used to remove residual lipopolysaccharides (LPS) from the cell membrane of *E. coli*. The toxicity and other properties of LPS can affect immunogenicity studies [40, 41].
4. The concentration can be derived from the UV spectra by using the Beer–Lambert law:

$$A = \epsilon bC$$

in which A represents absorbance at the given wavelength, ϵ is the molar absorptivity at that wavelength, b is the path length of the sample in centimeters, and C is the sample concentration.

$$C = \frac{A_{280} - 10^{(2.5 \log \frac{A_{320}}{A_{280}} - 1.5 \log \frac{A_{350}}{A_{280}})}}{5540n_{\text{trp}} + 1480n_{\text{tyr}} + 134n_{\text{s-s}}}$$

The above equation measures C at an absorbance of 280 nm, for a 1 cm path length cuvette. It is based on the molar extinction coefficients of 5540 M⁻¹ cm⁻¹ for tryptophan, 1480 M⁻¹ cm⁻¹ for tyrosine residues, and 134 M⁻¹ cm⁻¹ for cysteine. Optical density or apparent absorbance is collected at A_{280} , A_{320} , and A_{350} . n is the number of each respective amino acid in the protein sequence [27, 28].

5. Bicinchoninic acid (BCA) and Bradford assays can help circumvent the issues due to the presence of nucleic acid in determining protein concentration. However, as bovine serum albumin (BSA) may not be an accurate standard or representation of a particular VLP, VLP standards should be used if available.
6. For spherical particles, the Stokes–Einstein equation defines the relationship between the size of the particle and the diffusion coefficients (D).

$$D = \frac{k_{\text{B}}T}{3\pi\eta(t)d}$$

d is particle diameter, k_{B} is Boltzmann's constant, T is temperature (Kelvin), and η is liquid viscosity in centipoise. Irregular shapes that are non-spherical will not be accurately represented. Complementary techniques such as particle

shape characterization by flow imaging, molecular weight by asymmetric flow field-flow fractionation coupled with multi-angle light scattering, and analytical ultracentrifugation should be used [42–45]. Small-angle neutron and X-ray scattering are also sensitive to different shapes and form factors [46].

7. Morphological features of VLPs can be enhanced by using cryo-electron microscopy [47, 48]. Cryo-EM uses electron microscopy under cryogenic conditions ($-180\text{ }^{\circ}\text{C}$ in liquid nitrogen and $-269\text{ }^{\circ}\text{C}$ for helium). No staining or drying protocol is used, better maintaining conditions similar to the native state of the protein. Near-atomic reconstructions of VLP subunit positions such as trimers and pentamers can be obtained. The cryo-EM models help in determining the symmetric positions or axes (i.e., threefold or fivefold symmetry) guiding self-assembly.

Acknowledgements

This project was supported by a grant from the National Institute of General Medical Sciences (P30GM110761) from the National Institutes of Health.

References

1. Caspar DL, Klug A (1962) Physical principles in the construction of regular viruses. In: Cold Spring Harbor symposia on quantitative biology. Cold Spring Harbor Laboratory Press, Cold Spring Harbor, NY, pp 1–24
2. Aires KA, Cianciarullo AM, Carneiro SM, Villa LL, Boccardo E, Pérez-Martinez G, Perez-Arellano I, Oliveira MLS, Ho PL (2006) Production of human papillomavirus type 16 L1 virus-like particles by recombinant *Lactobacillus casei* cells. *Appl Environ Microbiol* 72:745–752
3. Biemelt S, Sonnewald U, Galmbacher P, Willmitzer L, Müller M (2003) Production of human papillomavirus type 16 virus-like particles in transgenic plants. *J Virol* 77:9211–9220
4. Baschong W, Hasler L, Häner M, Kistler J, Aebi U (2003) Repetitive versus monomeric antigen presentation: direct visualization of antibody affinity and specificity. *J Struct Biol* 143:258–262
5. Liu W, Sohn HW, Tolar P, Pierce SK (2010) It's all about change: the antigen-driven initiation of B-cell receptor signaling. *Cold Spring Harb Perspect Biol* 2:a002295
6. Villa LL, Ault KA, Giuliano AR, Costa RL, Petta CA, Andrade RP, Brown DR, Ferenczy A, Harper DM, Koutsky LA (2006) Immunologic responses following administration of a vaccine targeting human papillomavirus Types 6, 11, 16, and 18. *Vaccine* 24:5571–5583
7. McAleer WJ, Buynak EB, Maigetter RZ, Wampler DE, Miller WJ, Hilleman MR (1984) Human hepatitis B vaccine from recombinant yeast. *Nature* 307:178–180
8. Shi L, Sings H, Bryan J, Wang B, Wang Y, Mach H, Kosinski M, Washabaugh M, Sitrin R, Barr E (2007) Gardasil®: prophylactic human papillomavirus vaccine development—from bench top to bed-side. *Clin Pharmacol Ther* 81:259–264
9. Jain NK, Sahni N, Kumru OS, Joshi SB, Volkin DB, Middaugh CR (2014) Formulation and stabilization of recombinant protein based virus-like particle vaccines. *Adv Drug Deliv* 19:42–55
10. Lua LH, Connors NK, Sainsbury F, Chuan YP, Wibowo N, Middelberg AP (2014) Bioengineering virus-like particles as vaccines. *Biotechnol Bioeng* 111:425–440

11. Roldão A, Mellado MCM, Castilho LR, Carrondo MJ, Alves PM (2010) Virus-like particles in vaccine development. *Expert Rev Vaccines* 9:1149–1176
12. Lorenzo LJ, Dueñas-Carrera S, Falcón V, Acosta-Rivero N, González E, de la Rosa MC, Menéndez I, Morales J (2001) Assembly of truncated HCV core antigen into virus-like particles in *Escherichia coli*. *Biochem Biophys Res Commun* 281:962–965
13. Middelberg AP, Rivera-Hernandez T, Wibowo N, Lua LH, Fan Y, Magor G, Chang C, Chuan YP, Good MF, Batzloff MR (2011) A microbial platform for rapid and low-cost virus-like particle and capsomere vaccines. *Vaccine* 29:7154–7162
14. Ludwig C, Wagner R (2007) Virus-like particles—universal molecular toolboxes. *Curr Opin Biotechnol* 18:537–545
15. Mach H, Volkin DB, Troutman RD, Wang B, Luo Z, Jansen KU, Shi L (2006) Disassembly and reassembly of yeast-derived recombinant human papillomavirus virus-like particles (HPV VLPs). *J Pharm Sci* 95:2195–2206
16. Sasnauskas K, Bulavaite A, Hale A, Jin L, Knowles W, Gedvilaite A, Dargevičiūtė A, Bartkevičiūtė D, Zvirbliene A, Staniulis J (2001) Generation of recombinant virus-like particles of human and non-human polyomaviruses in yeast *Saccharomyces cerevisiae*. *Intervirology* 45:308–317
17. Kost TA, Condreay JP (1999) Recombinant baculoviruses as expression vectors for insect and mammalian cells. *Curr Opin Biotechnol* 10:428–433
18. Coronel EC, Murti KG, Takimoto T, Portner A (1999) Human parainfluenza virus type I matrix and nucleoprotein genes transiently expressed in mammalian cells induce the release of virus-like particles containing nucleocapsid-like structures. *J Virol* 73:7035–7038
19. Rueda P, Fominaya J, Langeveld JP, Brusckhe C, Vela C, Casal JI (2000) Effect of different baculovirus inactivation procedures on the integrity and immunogenicity of porcine parvovirus-like particles. *Vaccine* 19:726–734
20. Schädlich L, Senger T, Kirschning CJ, Müller M, Gissmann L (2009) Refining HPV 16 L1 purification from *E. coli*: reducing endotoxin contaminations and their impact on immunogenicity. *Vaccine* 27:1511–1522
21. Ladenstein R, Fischer M, Bacher A (2013) The lumazine synthase/riboflavin synthase complex: shapes and functions of a highly variable enzyme system. *FEBS J* 280:2537–2563
22. Mejias MP, Ghersi G, Craig PO, Panek CA, Bentancor LV, Baschkier A, Goldbaum FA, Zylberman V, Palermo MS (2013) Immunization with a chimera consisting of the B subunit of Shiga toxin type 2 and *Brucella* lumazine synthase confers total protection against Shiga toxins in mice. *J Immunol* 191:2403–2411
23. Jardine J, Julien J-P, Menis S, Ota T, Kalyuzhniy O, McGuire A, Sok D, Huang P-S, MacPherson S, Jones M (2013) Rational HIV immunogen design to target specific germline B cell receptors. *Science* 340:711–716
24. Morgunova E, Illarionov B, Saller S, Popov A, Sambaiah T, Bacher A, Cushman M, Fischer M, Ladenstein R (2010) Structural study and thermodynamic characterization of inhibitor binding to lumazine synthase from *Bacillus anthracis*. *Acta Crystallogr D Biol Crystallogr* 66:1001–1011
25. Qin H, Hu J, Hua Y, Challa SV, Cross TA, Gao FP (2008) Construction of a series of vectors for high throughput cloning and expression screening of membrane proteins from *Mycobacterium tuberculosis*. *BMC Biotechnol* 8:51
26. Goodfellow M, Stackebrandt E (1991) Nucleic acid techniques in bacterial systematics. John Wiley, New York, NY
27. Mach H, Middaugh CR, Lewis RV (1992) Statistical determination of the average values of the extinction coefficients of tryptophan and tyrosine in native proteins. *Anal Biochem* 200:74–80
28. Mach H, Middaugh CR (1994) Simultaneous monitoring of the environment of tryptophan, tyrosine, and phenylalanine residues in proteins by near-ultraviolet second-derivative spectroscopy. *Anal Biochem* 222:323–331
29. Porterfield JZ, Zlotnick A (2010) A simple and general method for determining the protein and nucleic acid content of viruses by UV absorbance. *Virology* 407:281–288
30. Mach H, Middaugh C (1993) Measuring protein spectra in the presence of light scattering. *Biotechniques* 15:240–242
31. Lorber B, Fischer F, Bailly M, Roy H, Kern D (2012) Protein analysis by dynamic light scattering: methods and techniques for students. *Biochem Mol Biol Educ* 40:372–382
32. Koppel DE (1972) Analysis of macromolecular polydispersity in intensity correlation spectroscopy: the method of cumulants. *J Chem Phys* 57:4814–4820
33. Brown JC, Pusey P (1974) Measurement of diffusion coefficients of polydisperse solutes by

- photon correlation spectroscopy. *J Phys D Appl Phys* 7:L31
34. Einstein A (1905) Über die von der molekularkinetischen Theorie der Wärme geforderte Bewegung von in ruhenden Flüssigkeiten suspendierten Teilchen. *Ann Phys* 322: 549–560
 35. Bishop JB, Martin JC, Rosenblum WM (1991) A light scattering method for qualitatively monitoring aggregation rates in macromolecular systems. *J Cryst Growth* 110:164–170
 36. Egerton R (2006) Physical principles of electron microscopy: an introduction to TEM, SEM, and AEM. Springer Science & Business Media, New York, NY
 37. Tonomura A, MATSUDA T, Junji E, Todokoro H, Komoda T (1979) Development of a field emission electron microscope. *J Elect Microsc* 28:1–11
 38. Freitag B, Kujawa S, Mul P, Ringnalda J, Tiemeijer P (2005) Breaking the spherical and chromatic aberration barrier in transmission electron microscopy. *Ultramicroscopy* 102:209–214
 39. Bleloch A, Lupini A (2004) Imaging at the picoscale. *Mater Today* 7:42–48
 40. Berczi I, Bertok L, Bereznai T (1966) Comparative studies on the toxicity of *Escherichia coli* lipopolysaccharide endotoxin in various animal species. *Can J Microbiol* 12:1070–1071
 41. Beutler B, Rietschel ET (2003) Innate immune sensing and its roots: the story of endotoxin. *Nat Rev Immunol* 3:169–176
 42. Chuan YP, Fan YY, Lua L, Middelberg AP (2008) Quantitative analysis of virus-like particle size and distribution by field-flow fractionation. *Biotechnol Bioeng* 99:1425–1433
 43. Mach H, Arvinte T (2011) Addressing new analytical challenges in protein formulation development. *Eur J Pharm Biopharm* 78:196–207
 44. Pease LF, Lipin DI, Tsai DH, Zachariah MR, Lua LH, Tarlov MJ, Middelberg AP (2009) Quantitative characterization of virus-like particles by asymmetrical flow field flow fractionation, electrospray differential mobility analysis, and transmission electron microscopy. *Biotechnol Bioeng* 102:845–855
 45. Some D (2015) Biophysical characterization of VLPs. *Genet Eng Biotechnol News* 35:28
 46. Székely P, Ginsburg A, Ben-Nun T, Raviv U (2010) Solution X-ray scattering form factors of supramolecular self-assembled structures. *Langmuir* 26:13110–13129
 47. Benjamin J, Ganser-Pornillos BK, Tivol WF, Sundquist WI, Jensen GJ (2005) Three-dimensional structure of HIV-1 virus-like particles by electron cryotomography. *J Mol Biol* 346:577–588
 48. Johnson JE, Chiu W (2000) Structures of virus and virus-like particles. *Curr Opin Struct Biol* 10:229–235

Laboratory Scale Production of Recombinant Haa86 Tick Protein in *Pichia pastoris* and in *Escherichia coli* System

Binod Kumar, Azhahianambi P., and Srikant Ghosh

1 Introduction

Hyalomma anatolicum, a tick vector for *Theileria annulata* responsible for bovine tropical theileriosis, is prevalent in many parts of the world and almost all over India and causes heavy economic loss to livestock sector [1]. As an alternative to acaricide, the immunological control of ticks was found to be an effective component of the integrated control of the tick species [2]. In the line of success of Bm86-based vaccines against *Rhipicephalus (Boophilus) microplus* (TickGARD™, TickGARD plus™, and Gavac™) [3–5], the Bm86 homologue of *H. anatolicum* was expressed in both prokaryotic and eukaryotic expression systems, and its efficacy against both homologous and heterologous challenge were recorded [6, 7].

Purification of native midgut antigen from ticks is tedious, laborious, time-consuming, and low-yielding procedure. Immunization trials in large animals followed by commercialization of vaccines necessitate the production of antigens in bulk quantities. Recombinant DNA technology using prokaryotic or eukaryotic expression systems have been utilized for the generation of targeted proteins in bulk. Both the above systems have certain advantage and disadvantage over each other (Table 1). Yeast offers site-specific integration, increase in copy number, leader sequence for the secretion of heterologous protein, posttranslational modifications, fast growth, and low-cost media [8, 9]. Similarly, *E. coli*-based expression system is well known for its simplicity, flexibility, and inexpensive expression of target protein. Moreover, extensive information of genetics and vast availability of compatible tools for genetic manipulation makes the system very popular [10].

Table 1
Advantages and disadvantages of prokaryotic and eukaryotic expression system

Prokaryotic expression system	Eukaryotic expression system
Advantages	Advantages
<ul style="list-style-type: none"> • Easy cloning and genetic manipulation • Inexpensive to culture • Rapid growth and fast expression • Flexible in expression (multiple promoters, tags, fusion proteins, cleavage site, etc.) • Usually work well for intracellular proteins • Can be optimized for soluble expression vs inclusion bodies 	<ul style="list-style-type: none"> • Post-translational modifications are possible • Protein secreted in medium can easily be purified • Rapid growth and high expression
Disadvantages	Disadvantages
<ul style="list-style-type: none"> • Unavailability of eukaryotic post-translational modifications • Lack of some tRNA common to eukaryotic genes which severely limits the expression and necessitates codon optimization of the eukaryotic gene to be expressed • Difficult to express the gene of interest as secretory protein • Formation of inclusion bodies and failure of proper folding of some proteins 	<ul style="list-style-type: none"> • Comparatively longer time required for selection of high-expression clone • Inability to perform certain complex posttranslational modifications, such as prolyl hydroxylation and amidation as well as some types of phosphorylation and glycosylation • Over glycosylation

1.1 Importance of *Hyalomma anatolicum*

The H. anatolicum tick parasitize domestic (cattle, buffalo, sheep, and goat) and wild mammals and are abundant in semiarid zones of Asia, Near and Middle East, Southeastern Europe, and North Africa. In India, *H. anatolicum* has been incriminated as principal vector of *Theileria annulata*, *T. buffeli*, and *T. lestoardi* (*T. hirci*) in cattle, buffalo, and small ruminants [1, 11]. Besides *Theileria* species, the vector is responsible for transmitting human diseases and the subject has recently been reviewed [12]. The tick species follows a three-host life cycle under natural conditions, but under laboratory condition, (on rabbit-calf model) it follows two-host life cycle [13]. The tick species was established as homogenous (GenBank accession no. HM176656) *T. annulata* free acaricide susceptible reference tick line, IVRI line-II (national registration no. NBAII/IVRI/HA/1/1998), was maintained in rabbit-calf model, and was used as starting material. The major disadvantage of managing tick vectors by the application of chemical acaricides is the development of acaricide-resistant isolates [14].

1.2 Haa86

The Haa86 is a homologue of Bm86 in *H. anatolicum*. The Haa86 is a 657 amino acid long protein (1971 bp long gene, EU665682) having seven complete EGF-like domains. The identity of the EGF-like domains (domain 1–7) of Haa86 protein with the corresponding EGF-like domains of Bm86 was 78.3 %, 56.8 %, 60.9 %, 51.3 %, 62.2 %, 69 %, and 65.8 %, respectively. The amino acid sequence homology between Haa86 and Bm86 (Austrian strain) is 62.6 %. The N-terminal region of the protein has a 48 amino acid long putative signal sequence and C-terminal has a 32 amino acid anchoring sequence. Glycosylation of the Haa86 protein was confirmed by silver nitrate staining (Glycoprotein staining) [7].

1.3 Eukaryotic Expression Host (*Pichia pastoris*) and Vector (pPICZ α A)

Pichia pastoris is widely used as an expression host for the production of a variety of intra- and extracellular recombinant proteins. The expression vector used in *P. pastoris* is based on the strong, tightly regulated promoter of the *P. pastoris* major alcohol oxidase gene (*AOX*) [15, 16]; has bacterial plasmid elements, pUCori, for propagation and amplification of plasmid into bacteria; has different elements like α -factor secretion signal for efficient secretion of recombinant protein and 5'AOX1 promoter for plasmid integration to AOX1 locus of yeast chromosome; and allows methanol-inducible high-level expression of the gene of interest. The C-terminal polyhistidine (6 \times His) tag present in the vector is helpful for the purification of protein with metal-chelating resin and detection of protein using anti-histidine antibodies. Other genes associated with the yeast vector are ZeocinTM resistance (marker) gene and transcription termination sequence. The vector is integrated into the host chromosome which provides mitotic stability in the absence of selection.

1.4 Prokaryotic Expression Host (*Escherichia coli*) and Vector (pET32a)

To express the eukaryotic protein, normally *E. coli* and its compatible plasmid vector are the first method of choice, available with many molecular tools and protocols. For instance, lists of expression plasmids, a large number of engineered *E. coli* strains, and many cultivation strategies make the *E. coli* a perfect host to express the heterologous proteins [17]. However, many times expressed protein does not fold properly and form aggregates called inclusion bodies inside the *E. coli*. To avoid this happening, various strategies were used like expression at low temperature for short period of time or expression with highly soluble partner, such as thioredoxin (Thx), glutathione-S-transferase (GST), maltose-binding protein (MBP), etc., to improve the solubility of the expressed protein.

pET is a commercial prokaryotic expression vector (Novagen, USA) which was originally constructed by Studier and colleagues [18–20]. The pET32a is one of the important vectors of the pET series widely used in prokaryotic expression system. The vector possess a T7 promoter and terminator, thioredoxin (Trx) tag sequence, His-tag sequence, lacI gene, pBR322 and fl origin,

multiple cloning sites (MCS), ampicillin resistance gene, etc. It has many advantages over other expression vectors; the target gene is tightly regulated under strong T7 promoter for the transcription of gene and the leaky expression of T7 RNA polymerase was tightly regulated in host strain, *E. coli* BL21(DE3)PLysS, through production of small amount of T7 lysozyme. The T7 lysozyme acts as inhibitor of T7 RNA polymerase at low level [21]. A 109 amino acid length thioredoxin protein is expressed along with the target protein which improves the protein folding and solubility through disulfide bond formation and self-solubility. The *E. coli* strain NovaBlue or DH5 α cells are used for the initial cloning of target DNA into pET vectors and for maintaining plasmids because they are *recA*⁻ *endA*⁻ and have high transformation efficiencies and good plasmid yields. For the expression of recombinant, protein cloned in pET vector must be transformed into *E. coli* strain containing a chromosomal copy of the gene for T7 RNA polymerase like BL21(DE3), BL21(DE3)PLysS, etc. These hosts are lysogens of bacteriophage DE3, a lambda derivative that has the immunity region of phage 21 and carries a DNA fragment containing the *lacI* gene, the *lacUV5* promoter, and the gene for T7 RNA polymerase [17, 22]. The flow diagram of expression of targeted protein in heterologous system is presented below (Fig. 1).

2 Materials

2.1 Tick (*H. anatolicum*)

1. *H. anatolicum* reference strain (*see Note 1*).
2. Clean 25 ml collection vial.
3. Tick washing solution (3 % H₂O₂, 70 % ethanol, distilled water).
4. Electronic weighing machine.
5. Deep freezer (-20 and -80 °C).

2.2 RNA Isolation and cDNA Preparation

1. Diethylpyrocarbonate (DEPC)-treated mortar and pestle and 0.5, 1.5 and 2.0 ml Eppendorf tubes.
2. Nuclease-free filter tips (10, 200, 1000 μ l) and micropipettes.
3. Liquid N₂.
4. Reagent for RNA isolation: TRIzol™ Reagent (Invitrogen, USA), Molecular grade chloroform and isopropyl alcohol (Amresco, USA), nuclease-free water (NFW) (Ambion, USA), 70 % ethanol in nuclease-free water (mix 35 ml molecular grade absolute alcohol (Merck, Germany) in 15 ml NFW present in 50 ml nuclease-free tube), and RNaseZap® (Ambion, USA).
5. Tabletop refrigerated centrifuge (Hermle, Germany).
6. Spectrophotometer (NanoDrop) (Thermo Scientific, USA).

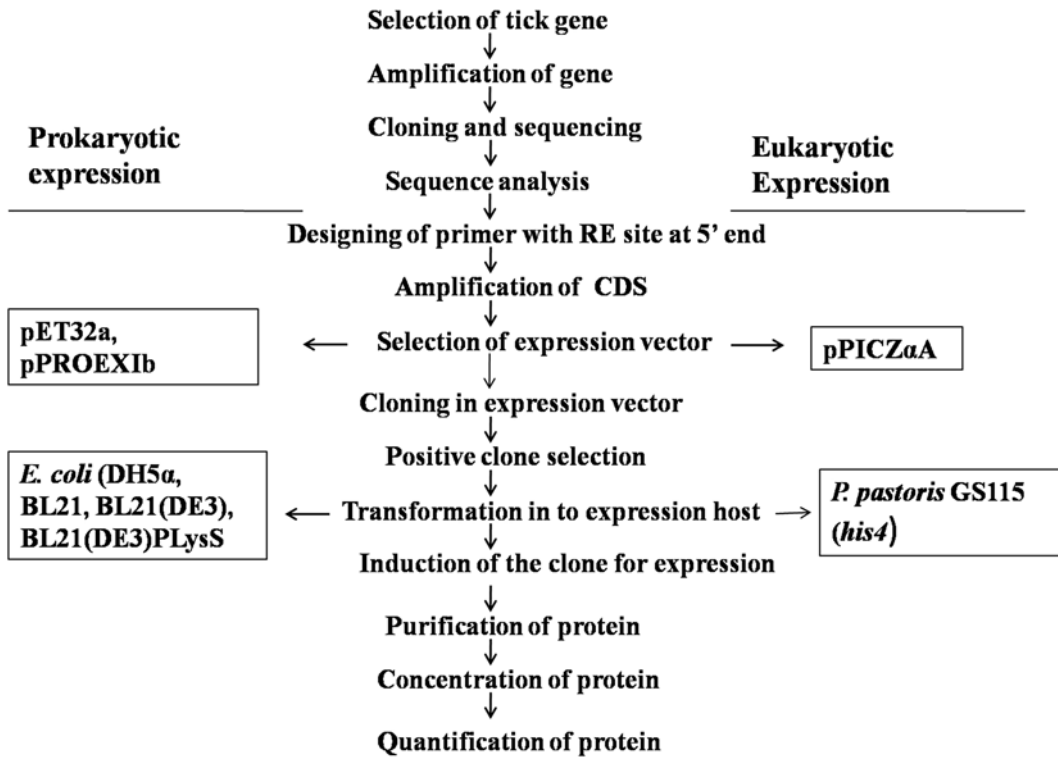

Fig. 1 Flow diagram of rHaa86 protein production

7. cDNA preparation reagent: RevertAid H Minus First Strand cDNA Synthesis Kit, (MBI Fermentas, USA) containing reverse transcriptase (RT), RNase inhibitor, oligo-dT, RT buffer, dNTPs, and NFW.
8. Temperature-controlled dry bath/water bath (Genei, India).
9. Deep freezer (-20 and -80 °C).

2.3 Cloning and Sequencing

1. PCR workstation, 0.2 ml PCR tubes, and PCR machine.
2. PCR reagents: 10× PCR Buffer, 10 mM dNTPs, Hot Start Taq DNA Polymerase (MBI Fermentas, USA), cDNA, NFW, and custom synthesized forward (HA1) and reverse primer (HA2) at working dilution of 10 μM conc. in NFW [HA1—5'CGGC GGATCC TTG TTC GTT GGC GCT ATT TTG CTC AT 3' and HA2—5'CCC GGTACC TCTAGA TGC AAC GGA GGC GGC CAG TAA 3'].
3. Agarose (Amresco, USA), 6× loading dye and GeneRuler™100 DNA Ladder Plus (MBI Fermentas, USA), and ethidium bromide (SRL, India) suitable for gel electrophoresis.

4. Agarose gel electrophoresis: for 25 ml of 1.0 % agarose gel, use 250 mg of ultrapure agarose (electrophoresis grade) with 25 ml of 1× TAE. Prepare 500 ml of 50× TAE stock solution in ultrapure water with 121 g of Tris base, 50 ml 0.5 M disodium EDTA (pH 8), and 28.55 ml glacial acetic acid.
5. Electrophoresis system with power pack (Applied Biosystem, USA).
6. Gel Documentation System (Syngene, UK).
7. Laminar air flow cabinet, tabletop centrifuge, and NanoDrop spectrophotometer.
8. QIAquick Gel Extraction Kit (Qiagen, Germany).
9. InsTAclone PCR Cloning Kit (MBI Fermentas, USA): includes vector (pTZ57R/T), 5× ligation buffer, T4 DNA ligase, NFW, *E. coli* growth media (C-media), and reagent for competent cell preparation (T-Sol A and T-Sol B).
10. *E. coli* strain DH5 α (F⁻ endA1 glnV44 thi-1 recA1 relA1 gyrA96 deoR nupG Φ 80 Δ lacZ Δ M15 Δ (lacZYA-argF)U169, hsdR17(r_K⁻ m_K⁺), λ -), culture plate, spreader, X-gal (20 mg/ml, MBI Fermentas, USA), 1 M IPTG (MBI Fermentas, USA) (dissolve the 23.83 mg IPTG in 1 ml of distilled water, filtered through the 0.22 mm syringe filter and stored at -20 °C), and ampicillin (MBI Fermentas, USA) (100 mg/ml), dissolve 100 mg of ampicillin Na in 1 ml of distilled water, filtered through the 0.22 mm syringe filter and stored at -20 °C.
11. Agar plate: Dissolve the Luria-Bertani (LB) agar (Amresco, USA) in 50 ml of distilled water (for two plate) and mix well by heating and autoclave for 15 min. Dissolve 100 μ l of X-gal, 25 μ l of 1 M IPTG, and 50 μ l ampicillin after cooling the autoclaved agar up to 50–60 °C. Pour the contents in presterilized culture plate. After solidification of agar, it can be immediately used or stored at 37 °C for 24–48 h covered in aluminum foil.
12. Stab culture tube: Add 1 ml of autoclaved LB agar mixed with ampicillin in sterile 1.5 ml Eppendorf tube, cool at room temperature and at 4 °C for 1 week.
13. DNA sequencing facility.

2.4 Sequence Analysis and Design of Expression Primer for Targeted Gene

1. GeneTool, DNASTAR software.
2. National Centre for Biotechnology (NCBI) BLASTn online server.

2.5 Expression of Haa86 in *Pichia pastoris*

1. PCR workstation, 0.2 ml PCR tubes, and PCR machine.
2. PCR reagent: 10× PCR Buffer, 10 mM dNTPs, Hot Start Taq Polymerase (MBI Fermentas, USA), template DNA (pTZHA86), NFW, and custom synthesized forward (HA3) and reverse primer (HA4) with suitable RE site (BamHI and

XbaI, respectively) at working dilution of 10 μ M conc. in NFW [HA3—5'CGGC GGATCC GGT AGA GAG GAT GAT TTC GTG TG 3' and HA4—5'CCC TCTAGA GTCGAC TGT TGC TTC TGT AGT TGT TGC TTC T 3']].

3. Agarose (Amresco, USA), 6 \times loading dye and GeneRuler™100 DNA Ladder Plus (MBI Fermentas, USA), and ethidium bromide (SRL, India) suitable for gel electrophoresis.
4. Agarose gel electrophoresis (*see* Subheading 2.3, item 4).
5. Agarose gel electrophoresis system with power pack (Applied Biosystem, USA).
6. Gel documentation system (Syngene, UK).
7. Laminar air flow cabinet, tabletop centrifuge, and NanoDrop spectrophotometer.
8. Restriction enzymes (RE): BamHI, XbaI, EcoRI, NotI, and PmeI and 10 \times buffer [Yellow Tango, Buffer (B+), Buffer (NEB), Orange (O+) buffer] (MBI Fermentas, USA).
9. Vector: Prokaryotic expression vector pPROEXHTb (Invitrogen, USA), prokaryotic cloning vector pBluescript II KS (+) (MBI Fermentas, USA), and yeast expression vector pPICZ α A (Invitrogen, USA).
10. T4 DNA ligase and 10 \times ligation buffer (MBI Fermentas, USA).
11. *E. coli* DH5 α competent cells (Invitrogen, USA).
12. Culture plate, spreader, X-gal (20 mg/ml, MBI Fermentas, USA), 1 M IPTG, and ampicillin (100 mg/ml) (*see* Subheading 2.3, item 10).
13. Agar plate (*see* Subheading 2.3, item 11).
14. Bacteriological and BOD incubators.
15. LB broth (Amresco, USA): dissolve 2.5 g of LB powder in 100 ml of distilled water and autoclave.
16. Shaker incubator.
17. SDS-PAGE system and reagents (30 % Acrylamide/Bis-acrylamide solution (29:1)), 10 % sodium dodecyl sulfate (SDS), 10 % ammonium persulfate (APS), 1.5 M Tris-HCl (pH 8.8), 1 M Tris-HCl (pH 6.8), and TEMED (Sigma, USA).
18. Running buffer: Dissolve 0.2 g SDS, 1 g Tris, and 14.5 g glycine in 1000 ml of distilled water.
19. Staining solution: Dissolve 0.02 mg Coomassie Brilliant Blue R250, 300 ml of methanol, and 100 ml of glacial acetic acid in 600 ml of distilled water and filter through grade 4 filter paper and store in amber colored bottle.
20. Destaining solution: Add 300 ml of methanol and 100 ml of glacial acetic acid in 600 ml of distilled water and store at room temperature.

21. Zeocin® (Invitrogen, USA) 100 µg/ml added LB agar (low salt, 0.5 %) plate.
22. QIAprep spin Miniprep Kit and QIAquick Gel Extraction Kit (Qiagen, Germany).
23. Mutant methylotrophic yeast strain: *Pichia pastoris* GS115 (*his4*) (Invitrogen, USA).
24. YPD (yeast extract peptone dextrose) agar medium (SRL, India).
25. Ice cold autoclaved distilled water and ice cold sterile 1 M sorbitol.
26. 0.2 cm sterile electroporation cuvette (Bio-Rad) and electroporation apparatus (Bio-Rad).
27. YPDS (yeast extract peptone dextrose sorbitol) agar plates containing 100 µg/ml of Zeocin® (Phleomycin D).

2.6 Culture and Purification of Yeast Expressed rHaa86

1. Glycerol stock of positive *P. pastoris* Haa86 clone.
2. Sterile BMGH (buffered minimal glycerol with histidine): To prepare 100 ml of medium, add 1.0 g yeast extract and 2.0 g peptone in 68.75 ml of distilled water, mix well, and autoclave for 15 min. After cooling add 10 ml each of 1 M potassium phosphate buffer pH 6.0, 10× yeast nitrogen base (34 g YNB and 100 g ammonium sulfate in 1000 ml of distilled water), and 10× glycerol (dissolve 100 ml glycerol in 900 ml of distilled water, autoclave for 15 min), 1 ml 100× L-histidine (dissolve 400 mg histidine in 100 ml distilled water, filter through 0.2 µ filter), and 250 µl 500× biotin (20 mg biotin in 100 ml distilled water, filter through 0.2 µ filter). BMGY (buffered glycerol-complex medium) is similar to BMGH medium without histidine.
3. Sterile BMMH (buffered minimal methanol with histidine) medium: To prepare 100 ml of medium, add 1.0 g yeast extract and 2.0 g peptone in 77.75 ml of distilled water, mix well, and autoclave for 15 min. After cooling add 10 ml each of 1 M potassium phosphate buffer pH 6.0 and 10× YNB, 1 ml absolute ethanol, 1 ml 100× L-histidine, and 250 µl 500× biotin.
4. Disruption buffer 1 (DB1) containing 50 mM sodium phosphate, 5 mM EDTA, 10 % sucrose, 0.3 M NaCl, and 2 mM 2-mercaptoethanol, pH 7.0.
5. Sonicator.
6. Disruption buffer 2 (DB2) containing 50 mM sodium phosphate, 5 mM EDTA, 0.5 % Triton X-100, 0.3 M NaCl, and 1 mM 2-mercaptoethanol, pH 7.0.
7. Washing buffer (WB) containing 50 mM sodium phosphate and 5 mM EDTA, pH 7.0.
8. Pre-extraction buffer (PEB) containing 50 mM sodium phosphate, 5 mM EDTA, and 0.8 M urea, pH 7.0.

9. Extraction buffer (EB) containing 50 mM sodium phosphate, 5 mM EDTA, 8 M urea, and 2 mM 2-mercaptoethanol, pH 7.0.
10. Refolding buffer (RB) containing 25 mM Na₂HPO₄ and 1.5 mM EDTA, pH 10.5.
11. 50 kDa cut off ultrafilter (PALL life sciences).
12. 1 N HCl.
13. SDS-PAGE system and reagents (*see* Subheading 2.5, item 17 and 18).
14. 25 % isopropyl alcohol, 7.5 % and 10 % acetic acid, and 0.2 % aqueous periodic acid in distilled water.
15. Freshly prepared filtered ammoniacal silver solution (100 ml containing 1.4 ml NH₄OH, 21 ml 0.36 % NaOH, and 4 ml 19.4 % AgNO₃).
16. Freshly prepared destaining solution (0.005 % citric acid, 0.019 % formaldehyde solution, and 10 % methanol).

2.7 Expression of Haa86 in *E. coli*

1. PCR work station, 0.2 ml PCR tubes, and PCR machine.
2. Haa86 positive clone (TA-cloning vector containing Haa86 insert).
3. PCR reagent: 10× PCR buffer, 10 mM dNTPs, Hot Start Taq Polymerase (MBI Fermentas, USA), template DNA (pTZHA86), NFW, and custom synthesized forward (HA3) and reverse primer (HA4) with suitable RE site (EcoRI and XhoI, respectively) at working dilution of 10 μM conc. in NFW (*see* Subheading 2.5, item 2).
4. Agarose (Amresco, USA), 6× loading dye and GeneRuler™100 DNA Ladder Plus (MBI Fermentas, USA), and ethidium bromide (SRL, India) suitable for gel electrophoresis.
5. Agarose gel electrophoresis (*see* Subheading 2.3, item 4).
6. Electrophoresis system with power pack.
7. Gel documentation system, tabletop centrifuge, and NanoDrop spectrophotometer.
8. Restriction enzymes (RE): EcoRI, XhoI, and 10× Tango yellow buffer (MBI Fermentas, USA).
9. Prokaryotic expression vector pET32(a) (Invitrogen, USA).
10. T4 DNA ligase and 10× buffer.
11. *E. coli* NovaBlue and BL21(DE3)PLysS competent cells (Invitrogen, USA).
12. Culture plate, spreader, 1 M IPTG, ampicillin (100 mg/ml), and chloramphenicol (34 mg/ml)—dissolve 34 mg chloramphenicol in 1 ml of absolute ethanol and store at -20 °C (*see* Subheading 2.3, item 10).
13. Agar plate with ampicillin (*see* Subheading 2.3, item 11), add only 50 μl ampicillin; do not use X-gal and IPTG.

14. Agar plate with ampicillin and chloramphenicol (*see* Subheading 2.3, **item 11**), add 50 μ l each of ampicillin and chloramphenicol; do not use X-gal and IPTG.
15. Bacteriological incubator.
16. LB broth (Hi-Media, India): dissolve 2.5 g of LB powder in 100 ml of distilled water and autoclave.
17. Shaker incubator.
18. QIAprep Spin Miniprep Kit and QIAquick Gel Extraction Kit (Qiagen, Germany).
19. SDS-PAGE system and reagents (*see* Subheading 2.5, **item 17**).
20. 6 \times sample buffer and molecular weight protein marker (Genei, India).
21. Running buffer, staining, and destaining solutions (*see* Subheading 2.5, **items 18–20**).

2.8 Culture and Purification of *E. coli* Expressed rHaa86

1. Glycerol stock of positive Haa86 *E. coli* clone [pET32(a) Haa86-BL21(DE3)PLysS].
2. Two 250 ml conical flask with 50 ml LB broth in each (dissolve 2.5 g of LB powder in 100 ml of distilled water and autoclave for 15 min).
3. 1 M IPTG, ampicillin (100 mg/ml), and chloramphenicol (34 mg/ml) (*see* Subheading 2.3, **item 10** and Subheading 2.7, **item 12**).
4. Shaker incubator.
5. 50 ml centrifuge tubes and centrifuge machine.
6. Lysis buffer (8 M urea, 100 mM NaH₂PO₄, 10 mM Tris, pH 8.0).
7. Ni-NTA superflow resin (Qiagen, Germany).
8. Washing buffer (8 M urea, 100 mM NaH₂PO₄, 10 mM Tris, pH 6.3 and 5.9).
9. Elution buffer (8 M urea, 100 mM NaH₂PO₄, 10 mM Tris, pH 4.5).
10. Different concentration of urea (6, 4, 2 M) in PBS pH 7.2.
11. Autoclaved PBS pH 7.2.
12. 10 kDa cutoff dialysis bag and protein cutoff filter.
13. Cocktail protease inhibitor (Amresco, USA).

3 Methods

A 1965 bp gene fragment of Haa86 was amplified by PCR with primers HA1 and HA2. This fragment was cloned into pTZ57R/T vector to obtain the construct pTZHA86 (Subheading 3.3). Sequence length of 144 bp from 5' end and 96 bp from 3' end was deleted from the ORF of Haa86 by performing PCR with primers HA3 and HA4. The shortened Haa86 ORF with the size of 1755 bp was cloned, and the resulting plasmid construct was designated as pPROHA86. The 1755 bp Haa86 gene fragment was subcloned into pBluescript II KS (+), and the recombinant construct was designated as pBLHA86. The size of the insert released from the pBLHA86 was digested with EcoRI and NotI and calculated to be 1799 bp. Finally, the 1799 bp Haa86 gene fragment was subcloned into *P. pastoris* expression vector to obtain the construct pPICHA86 (Fig. 2) (Subheading 3.5). To express the protein in prokaryotic expression system, the 1755 bp ORF of Haa86 was amplified using HA3 and HA4 primer pair and cloned into pET32a vector. After positive selection of clone, the recombinant plasmid (pETHA86) was transformed into expression host *E. coli*-BL21(DE3)PLysS (Subheading 3.7).

3.1 Collection of *Hyalomma anatolicum* Unfed Adult Tick

1. Collect the engorged nymphs from animal and incubate in BOD incubator for 10–15 days (*see Note 1*).
2. Wash the hatched out adult tick first in 3 % H₂O₂, followed by 70 % ethanol, and finally in distilled water. Soak dry the water adhered to ticks using paper towel (*see Note 2*).

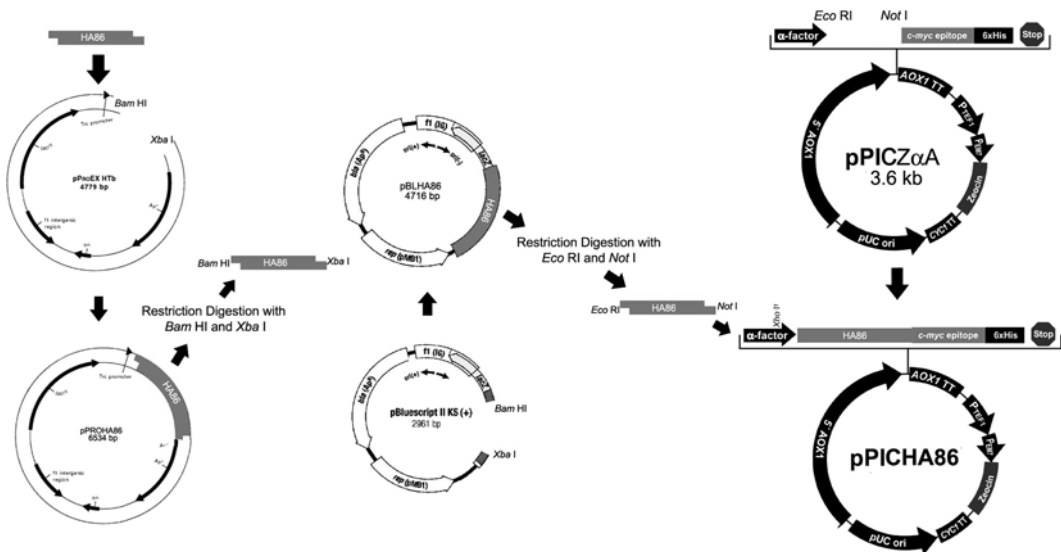

Fig. 2 Cloning strategies of Haa86 in eukaryotic expression vector (pPICZ α A)

3. Weigh 50 mg of adult tick in 1.5 ml autoclaved tubes and store at -80°C .

3.2 Whole RNA Isolation and cDNA Preparation

1. Day before RNA isolation, treat the mortar and pestle and 0.2, 1.5, and 2.0 ml tubes with 0.01 % DEPC in distilled water for overnight and autoclave (*see Note 3*). Wear gloves for entire process of RNA isolation.
2. Take out the preserved ticks from -80°C . Immediately make a small hole on cap of tube and dip in liquid nitrogen hanging through a piece of thread for 5 min (*see Note 4*).
3. Apply the RNaseZap[®] around the workplace (*see Note 5*).
4. Quickly add liquid nitrogen-treated ticks into mortar and grind it with the help of pestle.
5. Add 1 ml TRIzol[®] reagent and mix well (*see Note 6*).
6. Collect the mixture in 1.5 ml tube and incubate at 4°C for 30 min or -20°C for overnight.
7. Centrifuge at $14,000\times g$ for 10 min at 4°C and collect the upper aqueous phase into a new 1.5 ml tube kept on ice.
8. Add 200 μl of chloroform (0.2 volume of TRIzol) and vortex for 5–6 times (*see Note 7*).
9. Centrifuge at $14,000\times g$ for 10 min at 4°C and collect the upper aqueous phase into a new 1.5 ml tube kept on ice.
10. Add 500 μl of isopropyl alcohol (0.5 volume of TRIzol) and mix gently. Incubate for 10 min at 4°C or -20°C for overnight (*see Note 8*).
11. Pellet the RNA, centrifuge at $12,000\times g$ for 10 min at 4°C , and discard the liquid.
12. Wash the RNA pellet by adding 500 μl of 70 % ethanol in NFW, incubate for 5 min, and centrifuge at $10,000\times g$ for 2 min. Discard the liquid. Repeat this step for three times (*see Note 9*).
13. Air dry the RNA pellets and tube (*see Note 10*).
14. Add 50–100 μl of NFW, incubate on ice for 10 min, mix the RNA by mild tapping of the tube, and aliquot in 0.2 ml tubes.
15. Measure the concentration by taking OD at 260 nm using NanoDrop spectrophotometer and store at -80°C .
16. Prepare the cDNA following the kit protocol (RevertAid H Minus cDNA synthesis kit, Thermo Scientific, USA) using oligo-dT primer.
17. Store the cDNA at -20°C .

3.3 Cloning and Sequencing of Haa86 Gene

1. Custom synthesis of oligo primer based upon conserved region of tick gene (*see Note 11*).
2. Amplification of the targeted gene: For 25 μl reaction add 2.5 μl $10\times$ Taq buffer, 0.5 μl 10 mM dNTPs, 1 μl each of 10 mM for-

ward (HA1) and reverse (HA2) primer, 1 μ l (10–100 ng) cDNA, 0.3 μ l Hot Start Taq Polymerase (5 unit/ μ l), and NFW to make 25 μ l. Run the PCR as initial denaturation at 95 °C for 5 min and further 30 cycles at 94 °C for 1 min, 57 °C for 1 min, and 72 °C for 2 min and a final extension at 72 °C for 10 min.

3. Extraction of amplified product: Resolve the PCR product in 1 % agarose gel along with 100 bp plus DNA ladder, slice out the gel region containing targeted amplicons. Isolate the amplicons from gel slice following the protocol and reagent of gel extraction kit.
4. Quantify the amplicons concentration using NanoDrop spectrophotometer.
5. Setting of ligation reaction: Follow the guidelines of InsTAclone PCR Cloning Kit with slight modification. Typically for 30 μ l reaction, add 3 μ l vector (pTZ57R/T) and 5 μ l gel-purified product in a 0.2 ml PCR tube and incubate at 65 °C for 5 min and then add 6 μ l 5 \times buffer, 1 μ l T4 DNA ligase, and 15 μ l nuclease-free water. The ligation reaction is to be incubated at 4 °C overnight and then heat killed at 70 °C for 10 min (*see Note 12*).
6. Preparation of *E. coli* DH5 α competent cells: Follow the guidelines of InsTAclone PCR Cloning Kit (*see Note 13*).
7. Transformation of ligated product into *E. coli* DH5 α competent cells: Add 2 μ l of ligation product into 1.5 ml tube kept on ice and subsequently transfer 50 μ l competent cell suspension in it. Incubate for 5 min on ice. Spread the transformed cell suspension on to the pre-warmed (37 °C) LB agar plate containing X-gal, IPTG, and ampicillin using sterile spreader under laminar air flow. After drying of surface moisture, wrap the plate in aluminum foil and incubate at 37 °C upside down in a bacteriological incubator for overnight (*see Note 14*).
8. Select white bacterial colony from the plate having circular circumference (*see Note 15*).
9. Confirmation of the positive colonies by colony PCR: Take small part of the colony in 50 μ l NFW present in 0.5 ml tube using bacteriological loop or 10 μ l tip. Boil for 10 min in boiling water bath and centrifuge at 12,000 $\times g$ for 2 min. Use the supernatant as template DNA in a PCR reaction as stated above (*see Subheading 3.3, step 2*).
10. Growing of the colony in LB broth containing 100 μ g/ml ampicillin: Left over colony (after colony PCR mix) is transferred to a 5 ml LB broth containing 100 μ g/ml ampicillin (use 5 μ l of stock ampicillin) present in 50 ml sterile tube. Incubate at 37 °C, 150 rpm for 5–6 h.
11. Preparation of stab culture: Dip 10 μ l sterile tips in bacterial culture and pierce it into stab. Incubate at 37 °C for 12–16 h. Label it and send to DNA sequencing facility for nucleotide sequencing using 13 M forward and reverse primer. Positive recombinant plasmid can be designated as pTZHA86.

3.4 Sequence Analysis

1. Select the targeted sequence.
2. BLAST the sequence at BLASTn program of NCBI.
3. Select the coding DNA sequence (CDS) and identify the RE site within CDS.
4. Select the RE site(s) which are not present in CDS but available in multiple cloning sites (MCS) of the expression vectors.
5. Design the primer with different RE site(s) at 5' ends of both forward and reverse primer.
6. Add 2–4 nucleotides upstream of the 5' end before RE site.

3.5 Expression of Haa86 in *Pichia pastoris*

1. Amplification of Haa86 gene fragment (CDS) using primer HA3 and HA4: For 25 μ l PCR reaction, use 2.5 μ l 10 \times PCR buffer, 0.5 μ l dNTP, 1 μ l each of the primers HA3 and HA4, 1 μ l template DNA (pTZHA86), 0.3 μ l of Hot Start Taq Polymerase (MBI Fermentas, USA), and 18.7 μ l NFW. PCR condition to be set as initial denaturation at 95 $^{\circ}$ C for 5 min and further 30 cycles at 94 $^{\circ}$ C for 1 min, 47 $^{\circ}$ C for 1 min, and 68 $^{\circ}$ C for 2 min and a final extension at 68 $^{\circ}$ C for 10 min.
2. Run the PCR product in 1 % agarose gel and purify the targeted amplicons using gel extraction kit.
3. Quantify the concentration of amplicons using NanoDrop spectrophotometer.
4. Double digest the vector pPROEXHTb and amplicons separately with BamHI and XbaI restriction enzymes. Typically set 50 μ l reaction where 1 μ g of vector and 2 μ g of amplicons to be digested at 37 $^{\circ}$ C for 6 h in 1 \times Tango buffer by 2 unit each of RE.
5. Resolve the digested products separately in 1 % agarose gel and purify the digested products using gel extraction kit.
6. Setting up of ligation reaction for digested vector and amplicons: Add 10 \times ligation buffer (10 mM Tris-HCl, pH 7.5, 10 mM MgCl₂, 0.1 mg/ml BSA, 0.5 mM ATP), 70 ng of digested vector (pPROEXHTb), 200 ng of digested targeted gene, and 1 unit of T4 DNA ligase in 35 μ l reaction volume. Incubate at 4 $^{\circ}$ C overnight and heat inactivate the enzyme at 70 $^{\circ}$ C for 10 min.
7. Prepare the *E. coli* DH5 α competent cells (*see Note 13*).
8. Transform the ligated product in *E. coli* DH5 α competent cells (*see Subheading 3.3, step 7*).
9. Screen the positively transformed cells from culture plate (*see Subheading 3.3, step 9*).
10. Extraction of the plasmid (pPROHA86): Grow the PCR positive colony (leftover) in a 5 ml LB broth containing 100 μ g/ml ampicillin present in 50 ml sterile tube. Incubate in a shaking incubator

at 37 °C and 150 rpm for 4–5 h. Extract the plasmid using the protocol of QIAprep Spin Miniprep Kit and store at –20 °C.

11. Confirmation of positively transformed colony for expression of rHaa86: Grow the clone in 50 ml LB broth containing 100 µg/ml ampicillin (add 50 µl stock ampicillin) at 37 °C for 3 h. Subsequently, add 50 µl 1 M IPTG to it and continue the growth for next 4 h. Collect 1 ml culture and harvest the cell. Solubilize the harvested cells into 100 µl 1× sample buffer and boil for 10 min. After brief centrifugation, load 10 µl in SDS-PAGE. Observe the expressing colonies on gel after staining and destaining.
12. Releasing of gene insert from expressing pPROHA86 by BamHI and XbaI restriction enzymes: Set a 20 µl reaction contain 1 µg vector, 1× Tango buffer, and 1 unit each of BamHI and XbaI at 37 °C for 6 h. Purify the released product using gel extraction kit.
13. Digest the vector pBluescript II KS(+) with BamHI and XbaI restriction enzymes. Follow the above protocol.
14. Ligate the gene insert released from pPROHA86 and digested pBluescript II KS(+) (*see* Subheading 3.5, step 6).
15. Transform the ligated product into *E. coli* DH5α competent cells (*see* Subheading 3.3, step 7).
16. Screen the positively transform cells from culture plate (*see* Subheading 3.3, step 9).
17. Extract the plasmid (pBLHA86) from positive clone (*see* Subheading 3.5, step 10).
18. Releasing of gene insert from pBLHA86 by EcoRI and NotI restriction enzymes: Set a 50 µl reaction contain 2 µg vector, Orange (O+) buffer, and 1 unit each of EcoRI and NotI at 37 °C for 4 h. Purify the released product using gel extraction kit and quantify the concentration using NanoDrop spectrophotometer.
19. Digest the vector pPICZαA with EcoRI and NotI restriction enzymes. Follow the above protocol.
20. Ligate the gene insert released from pBLHA86 and digested pPICZαA (*see* Subheading 3.5, step 6).
21. Transform the ligated product into *E. coli* DH5α competent cells. Spread the transformed cells on to LB agar plate containing 100 µg/ml Zeocin® (*see* Subheading 3.3, step 7).
22. Screen the positively transform cells from culture plate (*see* Subheading 3.3, step 9).
23. Extract the plasmid (pPICZHA86) from positive clone (*see* Subheading 3.5, step 10).
24. Linearization of plasmid (pPICZHA86) by Pme I restriction enzymes: Set up 100 µl (25 × 4) reaction to linearize the pPICZHA86 with PmeI (MssI). Mix 20 µl vector (20 µg), 2 µl PmeI enzyme (20 unit) and 10 µl 10× Buffer (B+) in 68 µl of nucle-

ase-free water. Incubate the reaction at 37 °C for 12 h. Purify the digested product using gel extraction kit (*see Note 16*).

25. Preparation of electrocompetent *P. pastoris* GS115 (*his4*): Inoculate 1 ml glycerol stock of *P. pastoris* GS115 (*his4*) into 10 ml YPD medium and incubate in orbital shaker (280 rpm/28 °C/16 h). Subculture into 200 ml of YPD medium by adding 2 ml starter culture in orbital shaker (280 rpm/28 °C) to attain 1.5 OD₆₀₀. Pellet the cells at 1500×*g*/5 min/4 °C and resuspend in 200 ml of ice cold autoclaved distilled water. Again pellet the cell suspension and suspend in 20 ml ice cold sterile 1 M sorbitol. The cell suspension was kept on ice and immediately use for electro transformation (*see Note 17*).
26. Transformation of the linearized pPICZHA86 into electrocompetent *P. pastoris* GS115 (*his4*) cells: Collect the 80 µl cell suspension into an autoclaved 1.5 ml tube. Add 20 µl (7.5 µg) of the linearized pPICZHA86 and mix gently. Take this mixture into a sterile electroporation cuvette (0.2 cm) and incubate on ice for 5 min. Place the cuvette holder of the electroporation apparatus inside the laminar flow and fit the cuvette containing cells and DNA in it. Pulse the cells with a potential difference of 1.5 kV, resistance of 200Ω, and capacitance of 25 µF for 5 ms. Add 1 ml of ice cold sterile 1 M sorbitol into the cuvette immediately. Finally, incubate the cuvette at 30 °C for 1 h in BOD incubator without shaking.
27. Growing of transform cells on YPDS agar plates containing 100 µg/ml of Zeocin® (Phleomycin D): Spread 100 µl of the transformed cell suspension on the YPD agar plates containing 100 µg/ml of Zeocin® (Phleomycin D) and incubate the plate in BOD incubator at 30 °C for 72 h (Fig. 3).

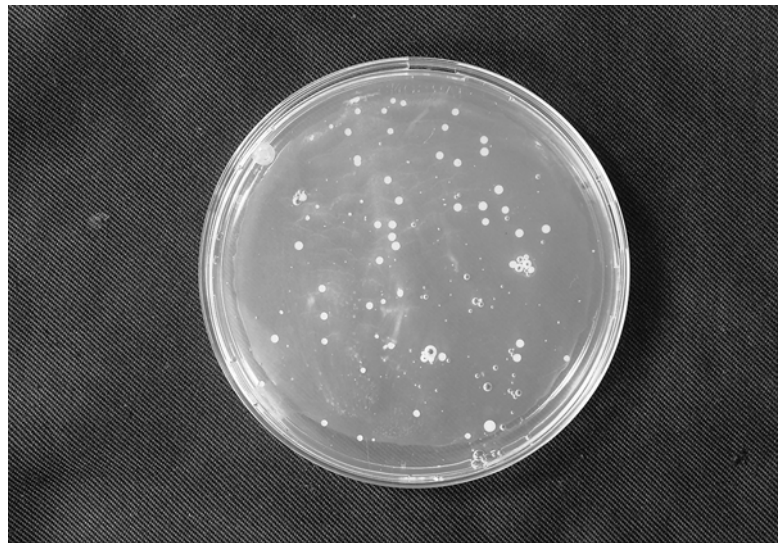

Fig. 3 Recombinant *Pichia pastoris* colony on YPD agar

28. Streaked some (10–15) of the good texture colony on new YPD agar plates containing 100 $\mu\text{g}/\text{ml}$ Zeocin[®]. Streaked the colonies separately on the YPD agar plates containing 100 $\mu\text{g}/\text{ml}$ Zeocin[®] and incubate in BOD incubator at 30 °C/48 h. Numbered the streaked colonies and store at 4 °C.
29. Screen 4–5 colonies for presence of insert through colony PCR (*see* Subheading 3.3, step 9).
30. Preparation of glycerol stock of the positive clone and storing at –80 °C: Culture the positively selected colonies into 10 ml BMGH media at 30 °C for 7 h and then add 1.7 ml autoclaved glycerol to it. Aliquot into 1 ml and store at –80 °C.

3.6 Purification of Yeast Expressed rHaa86 Protein

1. Growing of glycerol stock of positive clone(s) in basal minimum complex glycerol medium with histidine (BMGH): Inoculate 1 ml of *P. pastoris* HAA86 glycerol stock into 50 ml BMGH medium and grow in orbital shaker at 28 °C/230 rpm to reach 1.0 OD at 600 nm. Harvest the cell at 2000 $\times g$ /10 min/4 °C.
2. Growing in basal minimum complex methanol medium with histidine (BMMH): Resuspend the above harvested cells in 200 ml of BMMH medium and incubate in orbital shaker at 28 °C/230 rpm/120 h. Pellet the induced *P. pastoris* HAA86 culture at 14,000 $\times g$ /25 min.
3. Suspend the BMMH grown yeast pellet in disruption buffer 1 (DB1). Use 1.6 ml DB1 per gram of yeast pellet.
4. Sonicate the suspension at 10,000 Hz for 5 min interspersed with a period of cooling on ice. Pellet the cells by centrifugation at 20,000 $\times g$ /25 min.
5. Dissolve the pellet in disruption buffer 2 (DB 2) (4 volume of DB1) and incubate at 37 °C for 1 h on a shaker. Pellet the cells by centrifugation at 20,000 $\times g$ /25 min.
6. Pellet from DB2, dissolve in wash buffer (WB) (4 volume of DB2), and re-pellet it.
7. Dissolve the pellet in pre-extraction buffer (PB) (2 volume of wash buffer) and again re-pellet.
8. Suspend the pellet in WB (2 volume) again.
9. Finally, centrifuge to form pellet, dissolve into 2 ml of extraction buffer (EB).
10. Centrifuge at 30,000 $\times g$ for 25 min to collect the supernatant and store at –20 °C.
11. Add refolding buffer (RB) into the above supernatant after thawing. Dilute the supernatant with ten times of RB slowly for 8 h.
12. Concentrate the protein by 50 kDa cutoff ultrafilter. Collect the supernatant solution in cutoff filter and spin at 5000 $\times g$ for 50 min.

13. Precipitation of the contaminated yeast protein: Lower the pH of the supernatant solution to pH 4.8 by slowly adding 1 N HCl. Incubate at 4 °C for 15 min and precipitate the pellet at $16,000 \times g / 20 \text{ min} / 25 \text{ }^\circ\text{C}$.
14. Concentrate the purified rHaa86 protein by 50 kDa cutoff ultrafilter.
15. Resolve the protein on 8 % SDS-PAGE.
16. Staining of the gel with silver nitrate stain to determine glycosylation: After electrophoresis, soak the gel in 25 % isopropyl alcohol followed by 10 % acetic acid for overnight at room temperature then soak in 7.5 % acetic acid for 30 min. Transfer the gel in 0.2 % aqueous periodic acid for 1 h at 4 °C. Wash the gel with several changes of distilled water for 3 h. Treat gel with freshly prepared, filtered ammoniacal silver solution for 10 min. Immediately wash for 2 min in distilled water. Transfer the gel into freshly prepared solution containing 0.005 % citric acid, 0.019 % formaldehyde solution, and 10 % methanol. Wash the gel thoroughly in distilled water for 1 h with agitation and several changes.

3.7 Expression of Haa86 in Prokaryotic Expression System (*E. coli*)

1. Amplification of the targeted sequence: For 50 μl reaction add 5.0 μl 10 \times Taq buffer, 1.0 μl 10 mM dNTPs, 2 μl each of 10 mM forward (HA3) and reverse (HA4) primer, 1 μl (10–100 ng) Haa86 positive plasmid (pTZHA86), and 0.4 μl Hot Start Taq Polymerase (5 unit/ μl). Run the PCR as initial denaturation at 95 °C for 5 min and further 30 cycles at 94 °C for 1 min, 47 °C for 1 min, and 68 °C for 2 min and a final extension at 68 °C for 10 min.
2. Extraction of amplified product: Resolve the PCR product in 1 % agarose gel along with 100 bp plus DNA ladder and slice out the gel region containing targeted amplicons. Isolate the amplicons from gel slice following the protocol and reagent of gel extraction kit.
3. Quantify the amplicons concentration using NanoDrop spectrophotometer.
4. Digestion of the amplicons and expression vector (pET32a): Set up the reaction separately for amplicons and vector. For 20 μl reaction, use 2 μl vector (1 μg), 2 μl 10 \times RE buffer, 1 μl each of EcoRI and XhoI restriction enzymes, and 14 μl of NFW. Incubate at 37 °C for 2 h followed by 70 °C for 10 min. Similarly, use 0.2 μg of amplicons in reaction and follow the above guide lines. Purify both digested vector and amplicons using gel extraction kit.
5. Quantify the concentration of digested vector and amplicons.
6. Setting up of ligation reaction: Typically for 20 μl reaction, add 2 μl gel-purified digested vector (100 ng) and 5 μl gel-purified digested amplicons (250 ng) in a 0.2 ml PCR tube and incu-

bate at 65 °C for 5 min, then add 4 µl 5× buffer, 1 µl T4 DNA ligase, and 8 µl nuclease-free water. The ligation is incubated at 4 °C overnight and then heat killed at 70 °C for 10 min.

7. Transformation of ligated product into *E. coli* NovaBlue® competent cells: Add 2 µl of ligation mix into 0.5 ml tube containing pre-aliquoted 20 µl competent cell on ice. Incubate for 5 min on ice then give heat shock (immerse the tube for 45 s in water with a temperature of 42 °C and again put on ice). Incubate for 5 min on ice. Add 100 µl SOC media in the above tube at room temperature and incubate at 37 °C for 45 min. Spread the transformed cell suspension on pre-warmed (37 °C) LB agar plate containing ampicillin using sterile spreader under laminar air flow. After drying of surface moisture, wrap the plate in aluminum foil and incubate at 37 °C upside down in a bacteriological incubator for overnight.
8. Select the bacterial colony from the plate having circular circumference.
9. Confirmation of the positive colony by colony PCR: Take small part of colony in a 50 µl NFW using bacteriological loop or 10 µl tip in a 0.5 ml tube. Boil for 10 min in boiling water bath and centrifuge at 10,000 g for 2 min. Use the supernatant as a template DNA in a PCR reaction as stated above (*see* Subheading 3.7, step 1).
10. Growing of the PCR confirmed colony in LB broth containing 100 µg/ml ampicillin: Leftover colony after colony PCR mix in a 5 ml LB broth containing 100 µg/ml ampicillin present in 50 ml sterile tube. Incubate at 37 °C in a shaking incubator for 5–6 h.
11. Use QIAprep Spin Miniprep Kit for isolation of bacterial plasmid (pETHA86).
12. Testing for insert release: Set up the 20 µl plasmid digestion reaction. Use the vector digestion protocol (*see* Subheading 3.7, step 4).
13. Transformation of positive plasmid (pETHA86) into expression host *E. coli* BL21(DE3)PLysS (*see* Subheading 3.7, step 7). Use LB agar plate containing both ampicillin and chloramphenicol.
14. Growing of 5–6 bacterial colonies in LB broth containing 100 µg/ml ampicillin and 34 µg/ml chloramphenicol: Number the colonies using marker pen on plate. Take out half the colony from plate and add in 5 ml LB broth containing 100 µg/ml ampicillin and 34 µg/ml chloramphenicol present in 50 ml sterile tube. Incubate it at 37 °C in a shaking incubator for 3–4 h. Induce the culture by adding 5 µl of 1 M IPTG and grow additionally for 3–4 h. Keep one tube as uninduced, i.e., without IPTG.
15. Selection of the bacterial colonies having good expression: Collect 1 ml culture from each tube into labeled 1.5 ml

Eppendorf tube. Centrifuge at $12,000 \times g$ for 1 min. Discard the supernatant and dissolve the bacterial pellet into 50 μ l distilled water. Add 10 μ l 5 \times sample buffer and mix well. Boil the content present in 1.5 ml tube for 10 min in boiling water bath. Centrifuge at $12,000 \times g$ for 2 min. Load 10 μ l of this cell lysate in 10 % polyacrylamide gel containing SDS along with protein marker. Run the PAGE to resolve the proteins. After 20 min of staining into Coomassie Brilliant Blue R250 stain, destain the gel in destaining solution for 1–2 h. Observe the band of expressed protein in gel at expected molecular weight.

16. Preparation of glycerol stock of good expressed bacterial clone(s): Review the recorded data to identify clones having good expression by retrospective study of data recorded in data book. Grow the colony present in plate into 5 ml LB broth containing antibiotics as above for 4–5 h. Subculture in 2 ml LB broth containing antibiotics in 15 ml sterile tube. Add 200 μ l of bacterial culture and grow at 37 °C in a shaker incubator for 1 h. Place the tube on ice and add 330 μ l of pure sterile glycerol and mix it. Make the 0.5 ml aliquot in sterile 1.5 ml tubes. First freeze at –20 °C for 2–4 h and finally store at –80 °C.

3.8 Purification of Recombinant Protein

1. Preparation of fresh culture of positive clone: Thaw a glycerol stock of clone on ice and centrifuge at $10,000 \times g$ for 1 min to pellet the bacteria. Discard the supernatant and add the pellet into 5 ml LB broth containing 100 μ g/ml ampicillin and 34 μ g/ml chloramphenicol present in 50 ml sterile tube. Incubate in shaker incubator (37 °C and 150 rpm) for 5 h. Again subculture it in 5 ml LB broth with antibiotics as stated above, overnight.
2. Shake flask culture of bacterial clones: Autoclave 50 ml LB broth in a 250 ml flask, cool to 37 °C, and add 100 μ g/ml ampicillin, 34 μ g/ml chloramphenicol, and 500 μ l overnight cultured bacteria. Incubate in shaker incubator (37 °C and 150 rpm) for 3–4 h (till OD₆₀₀ reached 0.5–1.0). Induce the culture by adding 50 μ l of 1 M IPTG for the expression of protein in next 5 h at 37 °C.
3. Collection of bacterial lysate: Pellet the cultured bacteria by centrifuging at $10,000 \times g$ for 5 min. Discard the supernatant and record the weight of the pellet by subtracting the weight of empty centrifuge tube. Add 2 ml lysis buffer (5 ml/g of pellet) and mix properly. Incubate the mixture at 4 °C for 1 h and sonicate at 10,000 Hz for 30 s, 4–5 times with an interval of 60 s on ice. Centrifuge the content at $25,000 \times g$ for 30 min at 4 °C. Collect the clear lysate in a fresh tube and store at –20 °C.
4. Equilibration of the Ni-NTA superflow resin: Load the 1 ml Ni-NTA resin in column. Open the lower vent to remove the preservative. Subsequently, pass the 10 ml lysis buffer pH 8.0 through column. Close the lower vent before Ni-NTA beads are directly exposed to air.

5. Binding of protein with Ni-NTA: Mix the equilibrated Ni-NTA resin to lysate at room temperature and place on rocker for 30 min.
6. Elution of purified protein: Reload the Ni-NTA-lysate mix into column and open the lower vent. Wash the resin in column by flowing 10 ml each of wash buffer, pH 6.3, and wash buffer, pH 5.9, through the column. Finally, add the elution buffer pH 4.5. Collect the flow through in 1.5 ml tubes as 0.5 ml fraction up to 6–7 fractions.
7. Resolving eluted fractions in 10 % SDS-PAGE: Prepare the 10 % gel and load 10 μ l eluted protein along with 5 \times sample buffer (10 μ l protein+2 μ l sample buffer) after boiling for 10 min at water bath. In central well, load 8 μ l protein molecular weight marker. Stain and destain the gel and see the resolved protein bands using gel documentation and imaging system.
8. Removal of urea from the eluted fractions: Pool the fraction 2–6 (having high concentration of protein shown on SDS-PAGE) in 10 kDa molecular weight cutoff (MWCO) dialysis bag and dialyzed against descending order of urea concentration: 6, 4, and 2 M and finally in PBS pH 7.2 for 8–12 h at each concentration.
9. Concentration of the dialyzed protein: Collect the finally dialyzed protein from dialysis bag in a molecular weight cutoff filter, centrifuge at 5000 $\times g$ for 50–60 min at 4 $^{\circ}$ C. Measure the concentration of protein using spectrophotometer and add 10 μ l cocktail protease inhibitor in 1 ml of the final concentrated protein.
10. Properly label the tube and store the protein at 4 $^{\circ}$ C for short period and –20 $^{\circ}$ C for longer periods.

4 Notes

1. Healthy New Zealand white rabbits of 9 months to 1 year old and 1.5–2 kg in weight are to be used for feeding of larvae of *H. anatolicum*. After feeding, the engorged larvae will remain on rabbits to molt into unfed nymphs, which then attach and engorge. The engorged nymphs are to be collected and cleaned before placing in tick rearing glass vials. The tubes containing engorged nymphs are to be kept at 28 $^{\circ}$ C and in 85 % RH for molting. The freshly hatched adults were kept unfed for 7 days. The adults are to be released on more than 6-month-old cross-bred calves. The ear bags need to be checked daily, for collection of the fed adults. Collected adults are to be cleaned, weighed, labeled, and kept alone in the glass tubes at 28 $^{\circ}$ C and 85 % RH for oviposition [13].
2. Ticks should be cleaned in a cleaning solution to remove any surface-attached dirt and microbes.

3. DEPC (Diethylpyrocarbonate) used to inactivate and destroy the RNase. RNase is ubiquitously present everywhere in environment. To safeguard the extracted RNA from RNase, all the equipments and reagents should be free from RNase.
4. Hard exoskeleton of ticks becomes fragile when incubated in liquid N₂. It helps to break the tissue into fine particles to improve the total RNA extraction.
5. RNaseZap[®], a commercial product, contains the chemicals which inhibits the RNase ubiquitously present in environment. Apply this product on work surface and hand gloves to minimize the RNase contamination.
6. TRIzol[®] is a commercial product that contains phenol, guanidine isothiocyanate, and other proprietary components. It has very effective control over the RNase released from breaking cells and tissues [23]. This reagent is very effective for the isolation of high-quality total RNA from ticks.
7. Chloroform denatures the contaminated protein and converts soluble into organic phase.
8. Isopropyl alcohol precipitate the RNA. Overnight incubation at -20 °C gives better yields of RNA than 4 °C for 10 min.
9. Washing of RNA pellet is very essential to remove any contaminating chemicals present in it. RNA does not dissolve in 70 % ethanol but provide the environment to leach out the contaminating chemicals from RNA pellet.
10. Ethanol acts as an inhibitor in many downstream processing (cDNA preparation, PCR reaction) of RNA. Care should be taken to avoid RNA pellet over drying during ethanol evaporation. Before drying, add nuclease-free water in RNA pellet.
11. Based upon the conserved region of ticks gene available in GenBank (NCBI), either degenerate or normal primer is designed with the help of bioinformatics software like GeneTool, DNASTar, etc., which gives maximum length of nucleotide sequence of interest.
12. Ligation can be performed with different incubation temperature and time combinations. Here pre-incubation of vector and insert at 65 °C for 5 min significantly improves the ligation efficiency.
13. Cloning kit provides reagents for the preparation of competent cells. Alternatively, laboratory procedure can be followed. Grow *E. coli* DH5 α overnight in shaker incubator (37 °C, 120 rpm). One milliliter of this culture is to be seeded in 50 ml of autoclaved LB media and grow for 3 h at 37 °C, 120 rpm.

Harvest the cells by centrifuging at $7000 \times g/4^\circ\text{C}$ for 2 min. Suspend the cells in 17 ml sterile 0.1 M CaCl_2 (one third volume of the bacterial culture) and incubate on ice for 60 min. Pellet the cells and resuspend in 2 ml of solution containing 1.7 ml of 0.1 M CaCl_2 and 0.3 ml of autoclaved glycerol (15 % glycerol). Aliquot into 200 μl and store at -80°C .

14. For the transformation in competent cells, follow this protocol: After transferring the 5 μl of ligation mix into thawed competent cells, incubate on ice for 5 min, then give heat shock by short incubation at 42°C for 45 s, and immediately keep on ice for 30 min. Add 200 μl of freshly autoclaved LB broth and incubate at 37°C for 45 min in a shaker incubator. Use 200 μl to spread on agar plate and the rest is stored at 4°C .
15. For blue-white screening of recombinant clones, the design vector (pTZ57R/T cloning vector) has a short fragment of *lacZ* gene called α -fragment (*lacZ α*), whereas mutated host cells (like *E. coli* strain like DH5 α) has *lacZ* gene minus α -fragment (*lacZ α*) called ω -fragment (*lacZ Δ M15*) of β -galactosidase gene (*lacZ*). When the product of α -fragment combines with product of ω -fragment (called α -complementation), functional β -galactosidase is formed. The *lacZ α* fragment in vector contains multiple cloning sites (MCS) for inserting the targeted gene. When MCS are free of insert sequence, uninterrupted *lacZ α* produces α -fragment and functional β -galactosidase is formed which cleaves the X-gal (added in media), a colorless analogue of lactose, to form 5-bromo-4-chloro-indoxyl which gives the blue color, whereas when insert is present in MCS, the *lacZ α* is altered leading to absence of α -complementation and cleavage of X-gal, resulting in the absence of blue color development. Select only white, good size, lonely bacterial colony with circular circumference. Do not select the bacterial colony which is closely surrounded by small bacterial colonies.
16. Linearization of the recombinant *Pichia* vector is required for homologous recombination of the 5' *AOX1* and 3' *AOX1* with the *P. pastoris* genome and subsequent integration of the foreign gene into the *P. pastoris* genome.
17. The *P. pastoris* GS115 (*his4*) is a mutant methylotrophic yeast strain which cannot synthesize histidine de novo. The gene encoding histidinol dehydrogenase, involved in the histidine synthesis pathway, was disrupted in this strain.

Acknowledgements

Sincere thanks are due to Indian Council of Agricultural Research and Department of Biotechnology, Government of India, for providing funds to establish different protocols in the laboratory.

References

- Ghosh S, Bansal GC, Gupta SC, Ray DD, Khan MQ, Irshad H, M S, Seitzer U, Ahmad JS (2007) Status of tick distribution in Bangladesh, India and Pakistan. *Parasitol Res* 2:S207–S216
- de la Fuente J, Almazan C, Canales M, de la Lastra JM, Kocan KM, Willadsen P (2007) A ten-year review of commercial vaccine performance for control of tick infestations on cattle. *Anim Health Res Rev* 8:23–28
- Willadsen P, Bird P, Cobon GS, Hungerford J (1995) Commercialization of a recombinant vaccine against *Boophilus microplus*. *Parasitology* 110:S43–S50
- Canales M, Enriquez A, Ramos E, Cabrera D, Dandie H, Soto A, Falcon V, Rodriguez M, de la Fuente J (1997) Large scale production in *Pichia pastoris* of the recombinant vaccine Gavac™ against cattle tick. *Vaccine* 15:414–422
- Willadsen P, Kemp DH (1988) Vaccination with ‘concealed’ antigens for tick control. *Parasitol Today* 4:196–198
- Kumar B, Azhahianambi P, Ray DD, Chaudhuri P, de la Fuente J, Kumar R, Ghosh S (2012) Comparative efficacy of rHaa86 and rBm86 against *Hyalomma anatolicum anatolicum* and *Rhipicephalus (Boophilus) microplus*. *Parasite Immunol* 34:297–301
- Azhahianambi P, de La Fuente J, Suryanarayana VV, Ghosh S (2009) Cloning, expression and immunoprotective efficacy of rHaa86, the homologue of the Bm86 tick vaccine antigen, from *Hyalomma anatolicum anatolicum*. *Parasite Immunol* 31:111–122
- Eukart MR, Bussineau CM (1996) Quality and authenticity of heterologous proteins synthesized in yeast. *Curr Opin Biotechnol* 7:525–530
- Hollenberg CP, Gellissen G (1997) Production of recombinant proteins by methylotrophic yeasts. *Curr Opin Biotechnol* 8:554–560
- Sorensen HP, Mortensen KK (2005) Advanced genetic strategies for recombinant protein expression in *Escherichia coli*. *J Biotechnol* 115:113–128
- Jongejan F, Uilenberg G (2004) The global importance of ticks. *Parasitology* 129:S3–S14
- Ghosh S, Nagar G (2014) Problem of ticks and tick-borne diseases in India with special emphasis on progress in tick control research: a review. *J Vector Borne Dis* 51:259–270
- Ghosh S, Azhahianambi P (2007) Laboratory rearing of *Theileria annulata*-free *Hyalomma anatolicum anatolicum* ticks. *Exp Appl Acarol* 43:137–146
- Shyma KP, Kumar S, Sangwan AK, Sharma AK, Nagar G, Ray DD, Ghosh S (2013) Acaricide resistance status of *Rhipicephalus (Boophilus) microplus* and *Hyalomma anatolicum* collected from Haryana. *Indian J Anim Sci* 83:591–594
- Celik E, Calik P (2012) Production of recombinant proteins by yeast cells. *Biotechnol Adv* 30:1108–1118
- Balamurugan V, Reddy GR, Suryanarayana VVS (2007) *Pichia pastoris*: a notable heterologous expression system for the production of foreign proteins—Vaccines. *Indian J Biotechnol* 6:175–186
- Rosano GL, Ceccarelli EA (2014) Recombinant protein expression in *Escherichia coli*: advances and challenges. *Front Microbiol* 5:172
- Studier FW, Moffatt BA (1986) Use of bacteriophage T7 RNA polymerase to direct selective high-level expression of cloned genes. *J Mol Biol* 189:113–130
- Rosenberg AH, Lade BN, Chui DS, Lin SW, Dunn JJ, Studier FW (1987) Vectors for selective expression of cloned DNAs by T7 RNA polymerase. *Gene* 56:125–135
- Studier FW, Rosenberg AH, Dunn JJ, Dubendorff JW (1990) Use of T7 RNA polymerase to direct expression of cloned genes. *Methods Enzymol* 185:60–89
- Stano NM, Patel SS (2004) T7 lysozyme represses T7 RNA polymerase transcription by destabilizing the open complex during initiation. *J Biol Chem* 279:16136–16143
- Novy R, Morris B (2001) Use of glucose to control basal expression in the pET system innovations. *BioTechniques* 13:8–10
- Rio DC, Ares M Jr, Hannon GJ, Nilsen TW (2010) Purification of RNA using TRIzol (TRI reagent). *Cold Spring Harb Protoc* pdb. prot5439

Chapter 31

Production and Purification of Recombinant Filamentous Bacteriophages Displaying Immunogenic Heterologous Epitopes

Lei Deng, Florencia Linero, and Xavier Saelens

1 Introduction

The mammalian adaptive immune system typically responds vigorously to exogenous virus particles. For decades now, this property has been exploited to generate synthetic vaccines that comprise recombinant versions of such particles that are very well defined and noninfectious. Commercially successful examples of such viruslike particles (VLPs) include ENGERIX-B, distributed by GlaxoSmithKline, that is used as a vaccine against hepatitis B virus, and GARDASIL, distributed by Merck, that is used as a vaccine for the prevention of disease caused by human papillomavirus. These recombinant VLPs are produced and purified in the yeast *Saccharomyces cerevisiae*.

Recombinant DNA technology has allowed to introduce heterologous epitopes in the coding information of viral capsomers (the building blocks of virus particles and VLPs) in order to generate hybrid VLPs that display these epitopes on the surface of the resulting VLPs. A useful application of this technology is to dramatically increase the immunogenicity of the heterologous epitopes [1]. Filamentous bacteriophages are frequently used to display foreign epitopes [2]. Filamentous bacteriophages such as *E. coli* phages M13 and fd belong to the *Inoviridae* and use the F pilus as a receptor. A remarkable and very practical feature of these phages is that they replicate without killing the infected bacteria, but rather cause a persisting infection with newly assembled phages shedding from the host cells by a budding process [3]. Two viral coat proteins of these filamentous phages are used as fusion

partners to display foreign epitopes: the minor coat protein pIII that is present in five copies at one end of the virion and the major coat protein pVIII that is assembled in a helical fashion around the circular single-stranded DNA of the phage. Because the pIII protein is essential for F pilus recognition and is present in just five copies per phage, it is not the prime choice for the insertion of heterologous epitopes when increased immunogenicity against these epitopes is aimed for. The major coat protein pVIII is a much better choice for this purpose. However, this protein is just 50 amino acid residues in length [4], and insertion of extra amino acid residues may interfere with the biological function of pVIII, its role being to bind to the viral genome to assemble stable filamentous particles [5].

As a solution to this intrinsic problem, the Smith lab generated the type 88 fd system [6]. This elegant system contains two copies of gene *VIII* (hence the double “8” in fd88), which allows production of hybrid phages comprising both wild-type pVIII and recombinant pVIII (fused to an epitope of interest) without the need for a helper phage. In the fd-Tet system, a tetracycline resistance gene is inserted in the minus strand origin, and an extra copy of gene *VIII* is introduced in the noncoding region of the genome [7]. The expression of this additional gene *VIII* is controlled by a lac promoter and is accessible for the insertion of heterologous DNA by conventional molecular biology techniques. The resulting phage is slightly attenuated, and its double-stranded replicative form is genetically stable and maintained at low copy number in *E. coli* [8]. In general, plaques formed by filamentous bacteriophages are tiny and turbid and difficult to see with the naked eye. However, fd88-Tet-transduced *E. coli* cells are tetracycline resistant, which makes it practical to quantify the infectivity and number of viable phage particles. The percentage of recombinant pVIII carrying the exogenous epitope that is incorporated in the newly produced phages relative to wild-type pVIII may vary considerably, ranging from 5 % to 40 % depending on the length, amino acid properties, as well as other factors [9]. Steric hindrance and repulsive net charges of the inserted foreign peptide may also perturb virion assembly. In addition, the modified recombinant pVIII, with the foreign epitope inserted between the secretion signal and the mature pVIII coding information, is often poorly processed and membrane targeted by the host secretion machinery [9]. In any case, it is very important to try to determine the ratio of recombinant over wild-type pVIII coat proteins in the purified fd88 phages. One method is to separate the lower molecular size wild-type pVIII from the recombinant pVIII by using Tris/Tricine SDS-PAGE, followed by Western blot analysis using an anti-pVIII antibody.

Different foreign antigens have been displayed successfully on hybrid fd VLPs as fusions with the major coat protein pVIII phage,

including HIV-1-derived antigens [10–13], an amyloid- β -derived epitope [14] and a universal influenza A epitope [15].

The control of expression of the recombinant gene *VIII* is by the strong inducible hybrid *tac* promoter. This means that for the production of recombinant fd VLPs, *E. coli* strains with the strong *lacIq* repressor or *lacI+* are needed to expand the bacterial culture prior to induction of the *tac* promoter. Induction requires addition of isopropylthio- β -D-galactoside (IPTG) to the culture medium, which inactivates the *lacI* repressor and, in the absence of glucose, will result in transcriptional activation of the fd88 recombinant pVIII cistron.

In this chapter, we provide optimized methods for the expression, purification, and characterization of high-purity, infectious fd88 filamentous bacteriophage VLPs that display a foreign epitope. We also describe methods for biological and physical quality control of the resulting nanoparticles.

2 Materials

2.1 Bacteria and Media

1. Bacterial strains: *Escherichia coli* (*E. coli*) TGI cells bearing F episome (Pharmacia Biotech, Brussels, Belgium); Electro-competent *E. coli* DH5 α , F⁻ strain (NCCB, The Netherlands Culture Collection of Bacteria, Faculty of Biology, University of Utrecht, Utrecht, The Netherlands).
2. Lysogeny Broth (LB) medium: Dissolve 10 g tryptone, 10 g NaCl, and 5 g yeast extract in 950 ml deionized water and bring the volume up to 1 l. Autoclave with high-pressure saturated steam for 20 min at 121 °C. Store at room temperature (RT) or at 4 °C. In case antibiotic is needed, add at the desired concentration, shortly before use.
3. LB agar plates: Add 20 g/L agar to the LB medium before autoclaving as described above. After autoclaving, add antibiotics at the desired concentration when the medium is cooled to approximately 55 °C. Pour the liquid LB agar medium into 10 cm diameter petri dishes in a laminar flow. Allow the medium to solidify and air-dry. Plates can then be closed, inverted, and stored at 4 °C for up to 2 weeks.
4. Thousandfold concentrated tetracycline stock: Dissolve 400 mg tetracycline in 10 ml of distilled water. Filter-sterilize the solution by passing it through a 0.22 μ m filter using a syringe, and mix with an equal volume of autoclaved, cooled glycerol. The sterile stock solutions can be distributed into 1 ml aliquots and stored at -20 °C for future use. The working concentration of tetracycline in LB medium or LB agar plates that we use is 20 μ g/ml.

2.2 Production and Purification of Phages

1. PEG8000/NaCl solution: Dissolve 100 g of polyethylene glycol (PEG) 8000 and 116.9 g NaCl in a final volume of 475 ml of distilled water. After autoclaving, vigorously mix the solution when cooling down. Store the solution at RT.
2. Ten times concentrated Tris-buffered saline (TBS) pH 7.5: Dissolve 88 g NaCl and 60.5 g Tris base in 900 ml of distilled water. Adjust the pH to 7.5 with 1 M HCl. Add distilled water to a final volume of 1 l using a volumetric flask. The 10× stock solution can be autoclaved and stored at room temperature. Tenfold dilution of the stock buffer will result in a final molar concentration of 50 mM Tris and 150 mM NaCl, buffered at pH 7.5.
3. NaCl solution (80 mM): Dissolve 2.3 g NaCl in a final volume of 500 ml distilled water and autoclave the solution.
4. Thousandfold concentrated IPTG: Dissolve 2.38 g IPTG in 10 ml of distilled water. Filter-sterilize the solution using a 0.22 μm filter and a syringe. Aliquot the sterile IPTG solution into 1 ml batches and store at -20 °C.
5. NAP buffer: Dissolve 0.5 g NaCl in 100 ml distilled water (88 mM NaCl solution) and autoclave. In a separate bottle, dissolve 2.9 g NH₄H₂PO₄ in 40 ml distilled water, and adjust to pH 7.0 with 1 M NH₄OH. Add distilled water to a final volume of 50 ml (0.5 M NH₄H₂PO₄ solution) using a volumetric flask and autoclave. To prepare the NAP buffer, mix 90 ml 88 mM NaCl and 10 ml 0.5 M NH₄H₂PO₄.
6. Thin-wall polypropylene tube (transparent, 13.2 ml volume capacity) for use in ultracentrifuge rotor SW 41 Ti (Beckman Coulter, Inc., USA).
7. PPCO centrifuge bottle (500 ml volume capacity, Nalgene™, Thermo Fisher Scientific Inc., USA).
8. Polyallomer centrifuge bottle (50 ml volume capacity, 29 × 104 mm size, insertable in Sorvall SS-34 rotor).

2.3 Tris/Tricine Sodium Dodecyl Sulfate–Polyacrylamide Gel Electrophoresis (SDS–PAGE)

1. 30 % acrylamide/bis-acrylamide solution (29:1, AA/BAA): Dissolve 29 g acrylamide and 1 g of *N,N'*-methylene-bis-acrylamide in 60 ml of distilled water. Stir until the acrylamide and bis-acrylamide are dissolved, and add distilled water to a final volume of 100 ml. Filter the solution by passing it through a 0.45 μm filter and store at 4 °C.
2. Gel running buffer: Dissolve 72 g Tris base and 0.6 g of SDS in 150 ml distilled water. Adjust the pH to 8.45 with 1 M HCl. Add distilled water to a final volume of 200 ml using a volumetric flask. Final concentration is 3 M Tris/HCl, 0.3 % SDS, and pH 8.45.

3. Ammonium persulfate (APS) 10 % (w/v). Dissolve 1 g APS in 10 ml distilled water. Aliquot in 1 ml and store at 4 °C.
4. *N,N,N,N'*-tetramethyl-ethylenediamine (TEMED) (GE Healthcare, USA).
5. 1 M Tris-HCl buffer pH 6.8: Dissolve 60.57 g Tris base in 400 ml distilled water. Adjust pH to 6.8 by addition of 1 M HCl. Adjust to 500 ml final volume with distilled water using a volumetric flask.
6. Six times concentrated gel loading buffer: Dissolve 1 g SDS and 3.5 ml 1 M Tris-HCl (pH 6.8) in a 15 ml falcon tube using a 50 °C water bath. Then add 3.5 ml glycerol, 1 g dithiothreitol, and 1.2 mg bromophenol blue. Mix the loading buffer by inverting the Falcon tube a few times and then add water to a final volume of 10 ml. Aliquot the loading buffer into 1 ml batches and store at -20 °C. Add 42 µl β-mercaptoethanol to 1 ml of six times concentrated loading buffer just prior to use. Mix one part (v:v) of concentrated gel loading buffer with five parts of the protein sample.
7. 10 % SDS solution: Dissolve 10 g SDS in 100 ml distilled water by warming at 50 °C and store at RT.
8. Ten times concentrated anode buffer: Dissolve 120 g of Tris base in 400 ml distilled water. Mix and adjust to pH 9.0 with 1 M HCl. Add distilled water to a final volume of 500 ml using a volumetric flask. The final molar concentration of the ten times diluted solution is 200 mM Tris/HCl pH 9.0.
9. Ten times concentrated cathode buffer: Dissolve 60 g Tris base, 89.58 g Tricine, and 5.0 g SDS in 400 ml of distilled water. Mix and adjust the pH to 8.5 with 1 M HCl. Add distilled water to a final volume of 500 ml using a volumetric flask. To obtain a 1× solution, mix one part of the ten times concentrated buffer with nine parts distilled water. The final molar concentration of the 1× solution is 100 mM Tris/HCl, 100 mM Tricine, and 0.1 % SDS.
10. Coomassie brilliant blue staining solution: Weigh 100 mg Coomassie brilliant blue R-250 and dissolve in 50 ml methanol and 10 ml glacial acetic acid. Add distilled water to a final volume of 100 ml. The final concentration of the solution is 0.1 % Coomassie brilliant blue, 50 % methanol, and 10 % glacial acetic acid.
11. Destaining solution: Mix 200 ml methanol, 50 ml glacial acetic acid, and 250 ml distilled water. The final concentration of the destaining solution is 40 % methanol and 10 % glacial acetic acid.
12. Protein electrophoresis system (Bio-Rad Laboratories, Inc., USA).

13. Epson Perfection V330 Scanner (Epson, Japan).
14. Multicolor Low Range Protein Ladder (Thermo Fisher Scientific, Inc., USA).

2.4 Immunoblotting Components

1. Nitrocellulose membranes (pore size, 0.2 μm , Whatman, PerkinElmer, Item No. NBA083G001EA).
2. Ten times concentrated transfer buffer: Dissolve 30 g Tris base and 144 g glycine in 900 ml distilled water. Mix and adjust to pH 8.3 with 1 M HCl. Add distilled water to a final volume of 1 l. For a 1 \times concentrated solution, mix one part (v:v) of the ten times concentrated solution with seven parts distilled water and two parts of methanol. The final molar concentration of the diluted solution is 25 mM Tris, 192 mM glycine, and 20 % methanol.
3. Ten times concentrated phosphate buffer saline (PBS): Dissolve 80 g NaCl, 2 g KCl, 14.4 g Na_2HPO_4 , and 2.4 g KH_2PO_4 in 800 ml of distilled water. Adjust to pH 7.4 with 1 M HCl and add distilled water to a final volume of 1 l using a volumetric flask. To obtain a 1 \times concentrated solution, mix one part (v:v) of the 10 \times concentrated buffer with nine parts of distilled water. The final concentration of the solution is then 137 mM NaCl, 3 mM KCl, 10 mM Na_2HPO_4 , and 2 mM KH_2PO_4 .
4. PBS-Tween 0.1 % solution (PBST): Add 1 ml Tween-20 detergent to 1 l PBS.
5. Blocking solution (5 % milk in PBST): Dissolve 5 g of milk powder in 100 ml of PBST.
6. TE70X Semidry blotter (Hoefer Inc., USA).
7. Antibodies: Mouse anti-pVIII monoclonal IgG antibody (working dilution, 1/4000) (Progen, Sanbio B.V., the Netherlands); horseradish peroxidase-linked secondary sheep anti-mouse IgG antibody (working dilution, 1/2000) (GE Healthcare, UK).
8. Western blotting ECL substrate reagent (BD Biosciences, USA).
9. X-ray film (GE Healthcare, UK).

3 Methods

3.1 Expression and Purification of fd88-Tet Bacteriophages

3.1.1 Transformation and Pre-inoculum

1. Thaw two vials of frozen competent DH5 α *Escherichia coli* (*E. coli*) strain on ice for 3 min (*see Note 1*).
2. Add 50 ng purified fd88-Tet plasmid DNA, with or without the gene of interest directionally inserted to competent DH5 α *E. coli* cells, and incubate on ice for 30 min (*see Note 2*).
3. Heat shock the competent cells/DNA mixture for 1 min at 42 $^\circ\text{C}$. After the heat shock, immediately transfer the vials on ice for at least 2 min (*see Note 3*).

4. Add 400 μl of LB medium to the transformation mixture, and incubate in a thermoshaker at 37 °C for 1 h at 200 revolutions per minute (rpm).
5. Plate out 100 μl of the suspensions on tetracycline/LB agar plates, and incubate overnight at 37 °C (*see Note 4*).
6. Pick single colonies from the plate with transformants to inoculate 5 ml of tetracycline/LB medium (pre-inoculum cultures). Incubate the cultures at 37 °C overnight in a shaker at 200 rpm (*see Note 5*).

3.1.2 Large-Scale Production and Purification of Bacteriophages

1. Inoculate 100 μl of the pre-inoculum in 1 l LB medium containing 1 mM IPTG and 20 $\mu\text{g/ml}$ tetracycline. Divide the volume into two flasks of 2 L capacity. Grow the cultures until reaching an optical density $A_{\lambda=280}$ of 1.4 (*see Note 6*).
2. Centrifuge the culture at $7500 \times g$ at 4 °C for 30 min.
3. Aliquot 1 l supernatant containing the phages into four 500 ml PPCO centrifuge bottles. Add 0.15 volume of PEG8000/NaCl to each bottle and gently mix. Let the phage precipitation proceed by incubating at 4 °C for 2 h.
4. Centrifuge at $18,600 \times g$ at 4 °C for 30 min and resuspend the phage pellet in 30 ml TBS, and then transfer this suspension to a 50 ml polyallomer centrifuge bottle.
5. Centrifuge the TBS-phage suspension at $18,600 \times g$ at 4 °C for 10 min, and then pour off the clear supernatant into a 50 ml Falcon tube (*see Note 7*).
6. Repeat the phage precipitation by adding 4.5 ml PEG8000/NaCl solution to 30 ml of TBS-phage resuspension, and incubate at 4 °C for 1 h.
7. Collect bacteriophages by centrifugation at $18,600 \times g$ at 4 °C for 30 min, and dissolve the pellet in 10.75 ml sterile TBS.

3.1.3 CsCl Gradient Ultracentrifuge Purification

1. Add 4.83 g CsCl to 10.75 ml phage-containing sterile TBS solution, and dissolve by inverting the tube at least ten times. Transfer the solution into a 13.2 ml polypropylene tube, and centrifuge at $209,490 \times g$ at 4 °C for 40 h in a SW 41 Ti swinging bucket rotor.
2. Gently remove the ultracentrifuge tube from the bucket. The phages should be visible as an opaque band between the middle and the top of the centrifuge tube. Collect the phage particles by puncturing the tube with a 16-gauge needle just beneath the light-scattering band that is best visualized by shining a bright light downward into the tube (Fig. 1) (*see Note 8*).
3. Centrifuge the collected phage-containing solution at $251,000 \times g$ at 4 °C for 4 h. Discard the supernatant and resus-

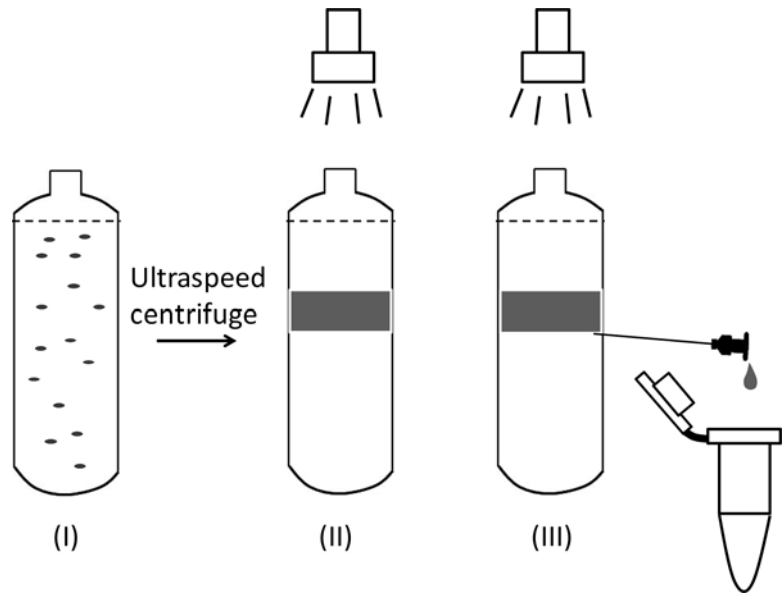

Fig. 1 CsCl gradient purification schematic diagram. The *gray particles* in (I) and *gray bands* in (II and III) represent phage substance. (I) phage solution is mixed with CsCl solution. (II) After ultraspeed centrifugation, the band of concentrated phage layer can be observed by naked eye under downward normal light beam. (III) Puncture the polyallomer tube using a 16-gauge needle, and collect concentrated phage solution

pend the resulting pellet in 0.5–3 ml sterile PBS. The phage preparation can be stored at $-80\text{ }^{\circ}\text{C}$ before use (*see Note 9*).

3.2 Titration of Filamentous Phage Tetracycline Resistance Transducing Units

3.2.1 Cell Starvation

1. Use 5 μl TG1 *E. coli* cells to inoculate 20 ml LB medium in a 125 ml flask at $37\text{ }^{\circ}\text{C}$, and shake at 200 rpm until an optical density of ~ 1.4 at $A_{\lambda=280}$ is reached (*see Note 10*).
2. Shake at 80 rpm at $37\text{ }^{\circ}\text{C}$ for 5 min to avoid shearing the fragile F pili in the following steps.
3. Centrifuge the culture at $580\times g$ at RT for 10 min. Discard the supernatant, and gently resuspend the bacterial pellet in 20 ml of 80 mM NaCl by pipetting up and down. Transfer the NaCl-bacteria resuspension to a 125 ml flask, and shake at 80 rpm at $37\text{ }^{\circ}\text{C}$ for 45 min to starve the cells.
4. Centrifuge at $580\times g$ at RT for 10 min, and resuspend the pellet in 1 ml cold NAP buffer on ice (*see Note 11*).

3.2.2 Titrate Transducing Units

1. Prepare 1/10 phage dilution series in a final volume of 30 μl per tube. Add 27 μl PBS in eight 0.5 ml sterile tubes, and start the series by adding 3 μl phage preparation in the first tube (10^{-1} dilution). Mix thoroughly by pipetting up and down.

Then using a new pipette tip, add 3 μl to the next tube (10^{-2} dilution). Repeat this till eight dilutions are made (dilution factors, 10^{-1} to 10^{-8}).

2. Add 20 μl TGI-starved bacteria in nine wells of a 24-well culture plate. Gently mix 20 μl of each of eight phage dilutions with the starved bacteria and incubate at RT for 10 min. One well containing 3 μl phage preparation without addition of TGI starved cells should be included as negative control.
3. Add 960 μl LB liquid medium to ten wells and gently shake the culture at 80 rpm at 37 °C for 30 min.
4. Plate 100 μl of the TGI cultures and of the phage only suspension on separate tetracycline/LB medium agar plates, incubate overnight at 37 °C.
5. To calculate the phage concentration, choose the plate with 50–200 independent colonies to count. Each colony represents one transducing unit (Fig. 2). Use the following formula to calculate the phage concentration: $\Upsilon = 500 \times X D$ (Υ phage preparation concentration, particles/ml; X , colony number on plate; D dilution factor) (see **Note 12**).

3.3 Characterization of M2e-Displaying Bacteriophages

3.3.1 Tris/Tricine SDS-PAGE Using Bio-Rad Protein Electrophoresis System

1. Prepare two 15 % Tris/Tricine SDS running gels (20 ml): 30 % acrylamide/bis-acrylamide, 10 ml; gel buffer (pH 8.45), 6.6 ml; distilled water, 1.2 ml; glycerol, 2 ml; 10 % APS, 0.2 ml; TEMED, 8 μl . Pour the preparation in two casted Bio-Rad gel cassettes with 10 ml for each cassette. Allow space for subsequently pouring the stacking gel and gently overlay the separation gel with deionized water.

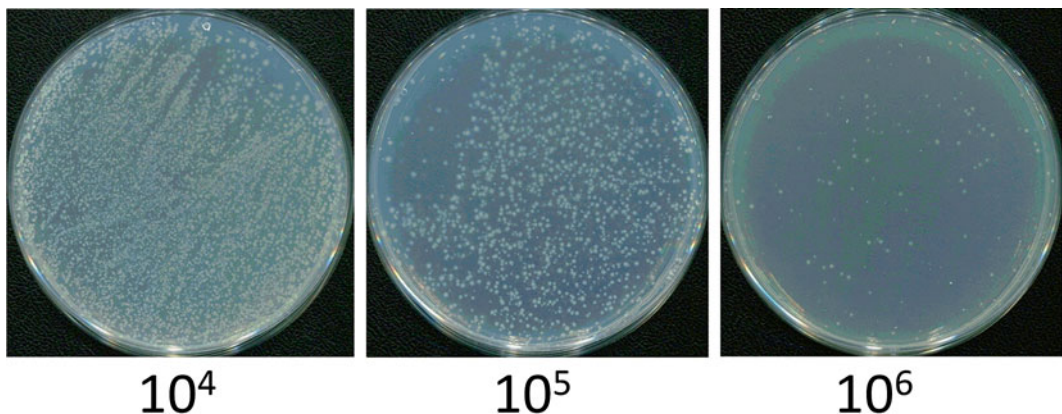

Fig. 2 F88-M2e phage preparation titration using TGI *Escherichia coli* strain containing F pilus. A 100 μl bacteriophage containing $\sim 5 \times 10^{10}$ tetracycline-transducing units were diluted with 10^4 , 10^5 , and 10^6 times and were plated on tetracycline-containing LB agar plates. Each colony forming unit represents one viable bacteriophage particle

2. After polymerization, pour off the deionized water and dry further with pieces of 3MM Whatman paper. Prepare 5 % stacking gels (10 ml): 30 % acrylamide/bis-acrylamide, 1.66 ml; 1 M Tris-HCl (pH 6.8), 1.26 ml; distilled water, 6.86 ml; 10 % SDS, 100 μ l; 10 % APS, 100 μ l; TEMED, 24 μ l. Once TEMED is added, immediately mix thoroughly and fill the space in the precast gel and insert a 15-well gel comb without introducing air bubbles.
3. Mix 1 μ g phage sample with the appropriate amount of six times concentrated loading buffer to obtain a final volume of 15 μ l. Denature the phage samples by boiling at 100 °C for 5 min. After this, shortly spin the tubes at the maximum speed for 30 s in an Eppendorf centrifuge.
4. Load the phage samples in the slots of the Tris-Tricine gels. Use 10 μ l Multicolor Low Range Protein Ladders as the marker in one well per gel. Add cathode and anode buffer, and start the gel electrophoresis at 100 voltage until the bromophenol blue reaches the bottom of the gel.

3.3.2 Coomassie Brilliant Blue Staining (See **Note 13**)

1. Remove the gel from the gel sandwich by lifting the top glass plate with a spacer, and then gently detach the gel from the glass plate. Stain the gel in 50 ml Coomassie brilliant blue staining solution for 1 h.
2. Pour off the Coomassie brilliant blue solution and add 100 ml destaining solution to the gel. Incubate the gel on a shaker, replacing the destaining solution every 10 min (*see Note 14*).
3. The stained protein bands can be scanned.

3.3.3 Immunoblotting

1. Wearing gloves, cut pieces of blot paper (Whatman 3MM) and nitrocellulose membrane with the same size as the gel. Immerse paper and activate the nitrocellulose membrane in 1 \times transfer buffer for at least 2 min.
2. Immediately following Tris/Tricine SDS-PAGE at **step 4**, stop the electrophoresis, remove gel from the gel sandwich by lifting the top glass plate with a spacer, detach the gel from the bottom glass plate, and soak the gel in 1 \times transfer buffer.
3. Place three sheets of blot paper on top of each other on the lower electrode of a semidry blotter, and then place the pre-wet membrane onto the stack of paper.
4. Place the gel on the membrane (*see Note 15*).
5. Cover the gel with another three layers of buffer-saturated blot paper. Then add some drops of 1 \times transfer buffer on top of the gel-membrane sandwich prior to closing the top electrode panel. Remove possible air bubbles between the layers by roll-

ing the gel-membrane sandwich with a plastic pipette (*see Note 16*).

6. Set the current based on multiplying the gel area by 0.8 mA/cm² and allow electro-transfer 1 h. (Due to the small molecular size of pVIII, around 8 kDa, the phage protein transfer can be complete within 1 h.)
7. Following blotting, carefully take out the membrane and incubate it in blocking solution at RT for 1 h (optionally, overnight at 4 °C). Optionally, the gel can be stained with Coomassie brilliant blue to detect residual proteins.
8. Incubate the nitrocellulose membrane with 10 ml mouse pVIII-specific primary antibody solution (antibody final concentration ~1 µg/ml) at RT for 3 h, and then wash the membrane three times with blocking solution, 10 min each time.
9. Incubate the membrane with horseradish peroxidase-linked secondary sheep anti-mouse antibody solution at RT for 1 h. Then wash the membrane three times with blocking solution and perform a final wash with PBST.
10. Incubate the nitrocellulose membrane in 5 ml Western blotting ECL substrate reagent for 1 min, and capture the emitted light by exposing an X-ray film to the emitted light.

4 Notes

1. Transformed *E. coli* typically yield transformation efficiency ranging from 10⁶ to 10⁸ cfu/µg DNA.
2. The volume of the DNA preparation should not exceed 5 % of the volume of the competent cells.
3. For the heat shock, a water bath or thermomixer is recommended. The heat shock can also be performed for 2 min at 37 °C.
4. Plate bacteria in the transformation mixture by transferring 100 µl of the transformation mixture onto a LB agar plate with tetracycline. Incubate the plate overnight at 37 °C. Bacteria in the transformation mixture can also be concentrated prior to plating. For this, centrifuge the transformation cultures at 1000 × *g* at RT for 3 min. After centrifugation, remove most of the supernatant, leaving approximately 100 µl of medium above the pelleted bacteria. Resuspend the bacteria in the medium, plate them out on tetracycline/LB agar plates, and incubate overnight at 37 °C. Preferentially, plate out bacteria in the afternoon; transformed bacteria colonies can be found on the plate in the morning of the next day. The number of colonies can fluctuate depending on the age and quality of the

competent cells, the purity of the plasmid DNA stock, and the amount of DNA added to the competent cell vial.

5. 50 ml Falcon tubes can be used for the 5 ml pre-inoculum culture.
6. A density $A_{\lambda=280} \approx 1.4$ indicates that bacteria are in the stationary phase of the culture, and this condition is normally reached after 8–12 h.
7. This step is mandatory in order to remove residual bacteria from the phage suspension.
8. The size and intensity of the band may vary depending on the amount of phage particles.
9. The volume of PBS should be adjusted to the thickness of the light-scattering band. If a weakly visible band is obtained, resuspend the pellet in a small volume of sterile PBS.
10. A density $A_{\lambda=280} \approx 1.4$ indicates the stationary phase of the culture, and in the conditions mentioned in this protocol, this is normally reached after 12–16 h.
11. The cell concentration is thereby adjusted to 10^{10} cells/ml. Theoretically, the higher the concentration of starved cell, the higher the rate of adsorption [16]. If these starved cells are not used on the same day, starved cells can be stored in the refrigerator for 5 days without affecting effectiveness of titration.
12. In general, choose the plate growing 50–200 colony number to obtain reliable counts. In our hands, the yield of fd88-M2e phage is $\sim 5 \times 10^{10}$ particles/ml.
13. Coomassie brilliant blue staining assure that the preparation contains pure bacteriophages in the absence of contamination. Normally only one stained band with the same size as pVIII should be visible in the gel. Extra bands indicate impurity of the bacteriophage preparation.
14. Overnight destaining is typically long enough for removing the background.
15. Proteins bind to the membrane as soon as contact occurs, so it is important to place the gel correctly on the first try. Readjusting the position of gel should be avoided.
16. Air bubbles between layers interfere with the current and the protein transfer. Buffer depletion is a common reason for failure of transfer. Buffer depletion leads to changes in pH of the transfer system and overheating, both of which are detrimental to the transfer.

References

1. Clarke BE, Newton SE, Carroll AR, Francis MJ, Appleyard G, Syred AD, Highfield PE, Rowlands DJ, Brown F (1987) Improved immunogenicity of a peptide epitope after fusion to hepatitis B core protein. *Nature* 330:381–384
2. Smith GP, Petrenko VA (1997) Phage display. *Chem Rev* 97:391–410
3. Smith GP (1988) Filamentous phage assembly: morphogenetically defective mutants that do not kill the host. *Virology* 167:156–165
4. Sugimoto K, Sugisaki H, Okamoto T, Takanami M (1977) Studies on bacteriophage fd DNA IV. The sequence of messenger RNA for the major coat protein gene. *J Mol Biol* 111:487–507
5. Greenwood J, Hunter GJ, Perham RN (1991) Regulation of filamentous bacteriophage length by modification of electrostatic interactions between coat protein and DNA. *J Mol Biol* 217:223–227
6. Zhong G, Smith GP, Berry J, Brunham RC (1994) Conformational mimicry of a chlamydial neutralization epitope on filamentous phage. *J Biol Chem* 269:24183–24188
7. Zacher AN, Stock CA, Golden JW, Smith GP (1980) A new filamentous phage cloning vector: fd-tet. *Gene* 9:127–140
8. Smith GP, Fernandez AM (2004) Effect of DNA copy number on genetic stability of phage-displayed peptides. *BioTechniques* 36(4):610–614, 616, 618
9. Malik P, Terry TD, Gowda LR, Langara A, Petukhov SA, Symmons MF, Welsh LC, Marvin DA, Perham RN (1996) Role of capsid structure and membrane protein processing in determining the size and copy number of peptides displayed on the major coat protein of filamentous bacteriophage. *J Mol Biol* 260(1):9–21
10. De Berardinis P, Sartorius R, Fanutti C, Perham RN, Del Pozzo G, Guardiola J (2000) Phage display of peptide epitopes from HIV-1 elicits strong cytolytic responses. *Nat Biotechnol* 18:873–876
11. De Berardinis P, Sartorius R, Caivano A, Mascolo D, Domingo GJ, Del Pozzo G, Gaubin M, Perham RN, Piatier-Tonneau D, Guardiola J (2003) Use of fusion proteins and procaryotic display systems for delivery of HIV-1 antigens: development of novel vaccines for HIV-1 infection. *Curr HIV Res* 1:441–446
12. di Marzo VF, Willis AE, Boyer-Thompson C, Appella E, Perham RN (1994) Structural mimicry and enhanced immunogenicity of peptide epitopes displayed on filamentous bacteriophage. The V3 loop of HIV-1 gp120. *J Mol Biol* 243:167–172
13. De Berardinis P, D'Apice L, Prisco A, Ombra MN, Barba P, Del Pozzo G, Petukhov S, Malik P, Perham RN, Guardiola J (1999) Recognition of HIV-derived B and T cell epitopes displayed on filamentous phages. *Vaccine* 17:1434–1441
14. Frenkel D, Katz O, Solomon B (2000) Immunization against Alzheimer's beta-amyloid plaques via EFRH phage administration. *Proc Natl Acad Sci U S A* 97:11455–11459
15. Deng L, Ibañez LI, Van den Bossche V, Roose K, Fiers W, Saelens X (2015) Protection against influenza A virus challenge with M2e-displaying filamentous *E. coli* phages. *PLoS One* 10(5):e0126650
16. Tzagoloff H, Pratt D (1964) The initial steps in infection with Coliphage M13. *Virology* 24:372–380

Oral Vaccine Development by Molecular Display Methods Using Microbial Cells

Seiji Shibasaki and Mitsuyoshi Ueda

Abstract

Oral vaccines are easier to administer than injectable vaccines. To induce an adequate immune response using vaccines, antigenic proteins are usually combined with adjuvant materials. This chapter presents methodologies for the design of oral vaccines using molecular display technology. In molecular display technology, antigenic proteins are displayed on a microbial cell surface with adjuvant ability. This technology would provide a quite convenient process to produce oral vaccines when the DNA sequence of an efficient antigenic protein is available. As an example, oral vaccines against candidiasis were introduced using two different molecular display systems with *Saccharomyces cerevisiae* and *Lactobacillus casei*.

Key words Oral vaccine, Molecular display, *Saccharomyces cerevisiae*, *Lactobacillus casei*, Cell surface, Candidiasis, *Candida albicans*

1 Introduction

Almost all vaccines for the prevention of infectious diseases are produced by the inactivation of virulent factors or purification of recombinant antigens. They are administered by injection in clinical situations. To ensure the safety of injected vaccines, a high level of purification is required, and this results in high production costs [1, 2]. Indeed, some purified antigens do not maintain their effect for long periods after vaccine injection. Moreover, conventional vaccines cannot induce the mucosal immune system due to the injection route. To overcome this limitation, we have developed oral vaccines using molecular display technology, with microbial cells as carriers of antigenic proteins and adjuvants (Fig. 1) [3–6].

1.1 Molecular Display Technology

Both gram-positive and gram-negative bacteria have been investigated as hosts for molecular display technology. Ståhl et al. have developed applications for molecular display using *Staphylococcus* [7], and it may be feasible to use *Lactobacillus* and *Lactococcus* to anchor foreign proteins. For example, *Bacillus subtilis* subsp.

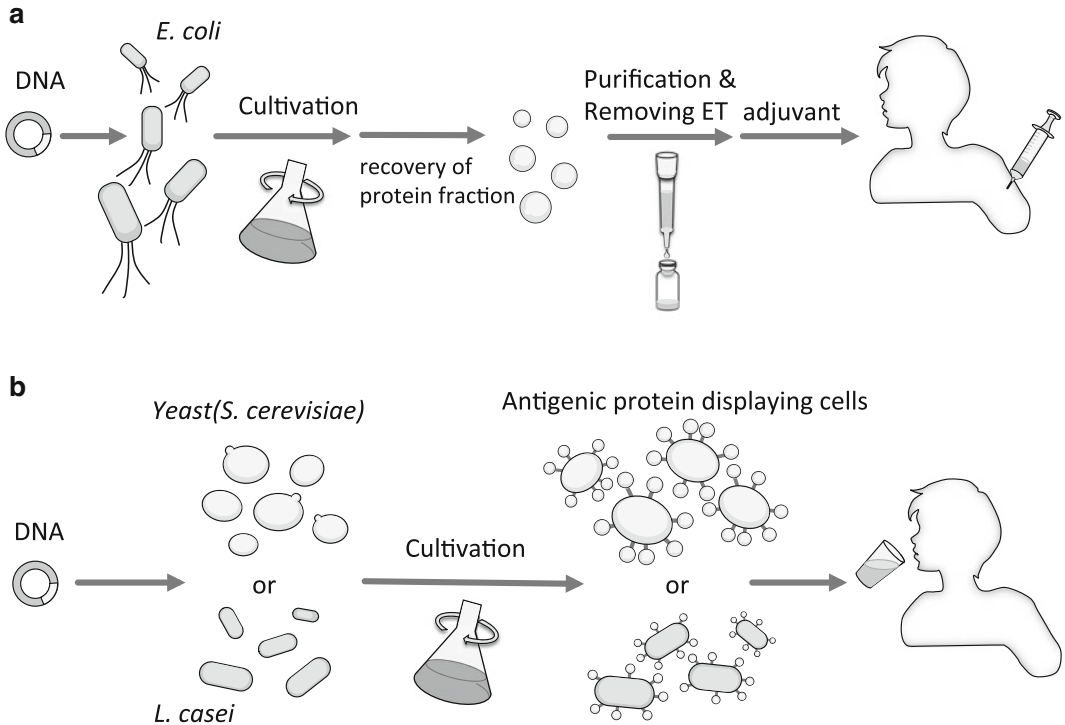

Fig. 1 Differences between conventional vaccines and oral vaccines developed by molecular display technology. **(a)** Conventional vaccines require a complicated procedure including purification, removal of endotoxins (ET), and the preparation of an adjuvant. **(b)** Oral vaccines by molecular display technology do not require such complicated steps. Additionally, microbial cells act as an adjuvant to enhance immune responses

chungkookjang PgsA [8] or *Streptococcus pyogenes* M6 can be used to display target proteins [9]. Although diverse microorganisms have been used to display foreign proteins, the display of eukaryotic proteins is sometimes difficult in bacterial cells.

The yeast *Saccharomyces cerevisiae* is a useful host cell for genetic engineering because it folds and glycosylates heterologous eukaryotic proteins. *S. cerevisiae* also has the advantage of high-density cultivation in inexpensive medium [10, 11]. In addition, it has the potential to display proteins of other eukaryotic taxa and can display several different proteins on the same cell surface. Therefore, molecular display using the yeast cell surface has many potential benefits and practical applications.

S. cerevisiae and *Lactobacillus* species are generally recognized as safe (GRAS) organisms, and engineered cells can be used to prepare oral vaccines without purification, unlike recombinant protein produced in *Escherichia coli*. In addition to display systems using yeast, the *Lactobacillus* system has also been well studied [12].

1.2 Platform for Molecular Display Using Yeast

Cwps, Flo1, and a- and α -agglutinins have been utilized for the display of proteins on yeast cell surfaces. There are two types of molecular display technologies that use Flo1 [13]. One is the GPI (glycosylphosphatidylinositol) system that uses the C-terminal region of Flo1; the C-terminus of the target protein is fused to that of Flo1. Another system is based on the adhesive ability of the flocculation functional domain of Flo1. The N-terminus of the target protein is fused to the flocculation functional domain. As a result, the target protein is displayed on the cell surface with keeping original N-terminal or C-terminal of it.

On the cell surface of *S. cerevisiae*, two types of agglutinins are expressed during mating. Mating-type a and α -cells produce a-agglutinin and α -agglutinin, respectively. α -Agglutinin in α -type cells is encoded by *AGa1* and interacts with the binding subunit of a-agglutinin of a-type cells. a-Agglutinin includes a core subunit encoded by *AGA1* and a binding subunit encoded by *AGA2* [14]. Both α -agglutinin and the core subunit of a-agglutinin consist of a secretion signal sequence, a functional domain, a supporting domain, and a GPI anchor attachment signal. To display foreign proteins on the cell wall, the genetic information for each agglutinin is available in the yeast system. The cell wall-anchoring domain of α -agglutinin is combined with the secretion signal sequence by genetic engineering (Fig. 2). For many years, fusion to the C-terminal half of α -agglutinin has been used to anchor foreign proteins on the yeast cell surface [10, 11]. Regarding vaccine development, *S. cerevisiae* itself is thought to have a better adjuvant function owing to the β -glucan in its cell wall [15].

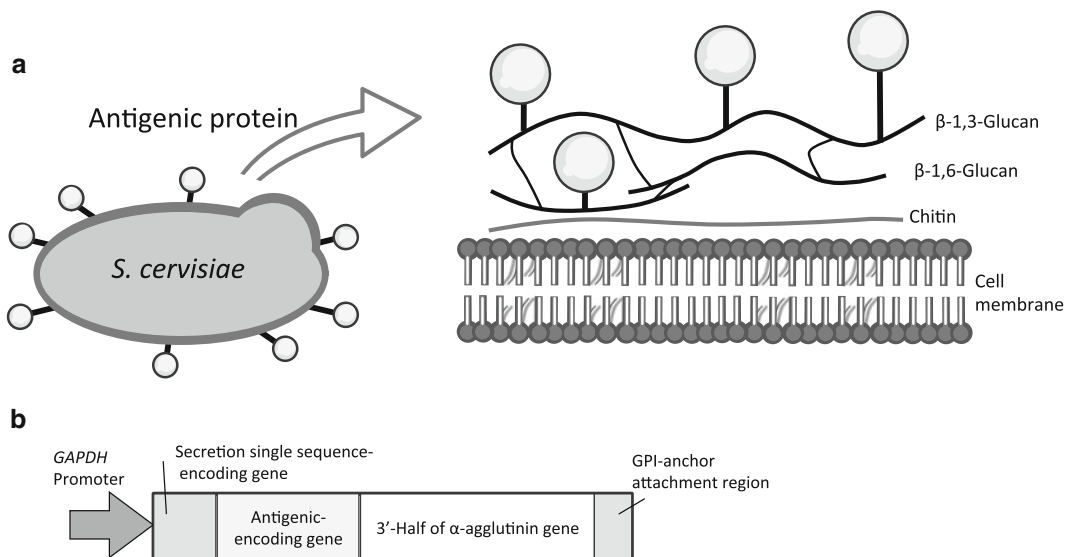

Fig. 2 Schematic illustration of the yeast cell surface and strategy for molecular display. **(a)** Yeast cell surface and display of the antigenic protein. **(b)** Genetic strategy for the display of antigenic proteins

1.3 Platform for Molecular Display Using *L. casei*

Many studies have examined the use of cell surface display using lactic acid bacteria for vaccines [16, 17]. Several investigations on molecular display technology have successfully used the C-terminal cell wall-anchoring LPXTG motif [18]. Several cell surface proteins in gram-positive bacteria have an anchoring domain that consists of an LPXTG motif followed by a hydrophobic domain at the predicted C-terminus. Proteins with the LPXTG motif are cleaved after translocation to the cell membrane [19].

Narita et al. developed a molecular display method in lactic acid bacteria using *Bacillus subtilis* subsp. *chungkookjang* PgsA as an anchor protein. PgsA is a transmembrane protein belonging to the poly- γ -glutamate synthetase complex [20]. It stabilizes the complex via anchoring in the cell membrane. This anchoring protein is able to fuse the target protein at its C-terminus. Since the transmembrane domain is situated at the N-terminus of PgsA, it is thought that the C-terminal half of PgsA is located outside the cell surface (Fig. 3) [21].

1.4 Candidiasis

Candidiasis is a serious infectious disease caused by the fungus *Candida albicans* and other *Candida* species [22]. Superficial or systemic candidiasis is observed when host immunity is compromised due to AIDS, chemotherapy for cancer treatment, or

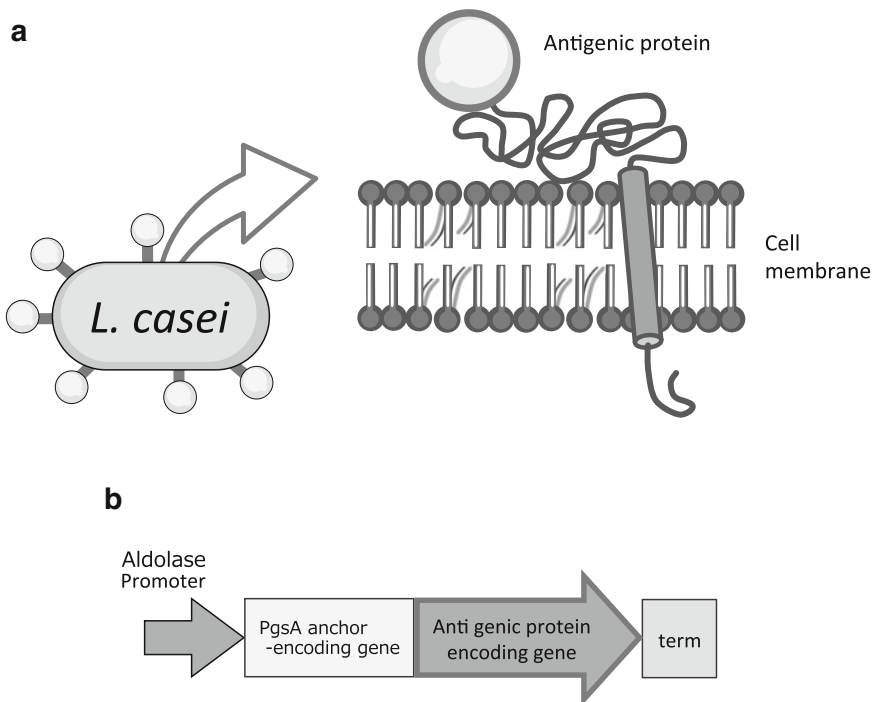

Fig. 3 Schematic illustration of the *L. casei* cell surface and strategy for molecular display. (a) Yeast cell surface and display of the antigenic protein. (b) Genetic strategy for the display of antigenic proteins

administration of an immunosuppressant. Caspofungin, micafungin, anidulafungin, and amphotericin B are often administered as pharmacotherapies for candidiasis. However, *Candida* mutants with reduced susceptibility to these pharmaceuticals have been identified during pharmacotherapy [23]. Therefore, prevention, i.e., a vaccination against *Candida* species, is thought to be important in addition to pharmacotherapy.

The Eno1 protein (Eno1p) (enolase 1, 2-phospho-D-glycerate hydrolase), an enzyme of the glycolytic pathway, has a protective effect against *C. albicans* infection [24]. Similarly, hyphal wall protein (Hwp1p), glyceraldehyde-3-phosphate dehydrogenase (Gap1p), and phosphoglycerate kinase (Ppk1p) exhibit protective immune functions against candidiasis [25] when they are administered with appropriate adjuvant compounds. For further development of an effective vaccine, convenient platform technology that enables the preparation of antigenic proteins is necessary. At present, conventional vaccines require an adjuvant to function as an effective antigen and induce the immune system (Fig. 1a). In this chapter, Eno1p is used as a model antigen to develop an oral vaccine using molecular display technology.

2 Materials

2.1 Vector

1. pQE30 *Escherichia coli* expression vector (Qiagen, Hilden, Germany, or other sources).
2. pYEX-BX yeast expression vector (Clontech, Palo Alto, CA, USA, or other sources).
3. pKV-Pald-pgsA380L *Lactobacillus casei* expression vector [12].

2.2 Microbial Strains

1. *E. coli* strain DH5 α [F^- *endA1 hsdR17* (r_K^- , m_K^+) *supE44 thi1 recA1 gyrA96 Δ lacU169 δ ϕ 80 lacZ Δ M15] [25] (Toyobo, Osaka, Japan).*
2. *E. coli* strain BL21 [F^- *ompT hsdSB* (r_B^- , m_B^-) *gal dcm* (DE3)] (Toyobo).
3. *S. cerevisiae* strain BY4741 (*MAT α his3-1 leu2 met15 ura3*) (GE Healthcare, Little Chalfont, UK).
4. *Lactobacillus casei* strain 525 [12].
5. *Candida albicans* strain SC5314 (American Type Culture Collection).

2.3 Media

1. LB medium, 1 % (w/v) tryptone, 0.5 % (w/v) yeast extract, 0.5 % (w/v) sodium chloride, and 0.1 % (w/v) glucose.
2. YPD medium, 1 % (w/v) yeast extract, 2 % (w/v) polypeptone, and 2 % (w/v) glucose.

Table 1
Primers for the development of oral vaccines using microbial cell surface

Primer	Sequence
ENO1-F	5'-ATGGATCCTCTTACGCCACTAAAATCCACGCC-3'
ENO1-R	5'-TAAAGCTTTTACAATTGAGAAGCCTTTTGGAAATCTTTACC-3'
GAP-PF	5'-ACTGAAAGCTTACCAGTTCTCACACGGAAC-3'
GAP-TR	5'-ATGCTGGTACCTCAATCAATGAATCGAAAATGTCATTAATAATAG-3'
MCS-F	5'-AATTGCAATTCATGCAACTGTTCAATTTGCCATTGAAAGTTTCATTCTTCTCGTCCTCTCTTACTTTTCTTTGCTCGTTTCTGCC-3'
MCS-R	5'-GACGGCTCGAGGCTAGCGCATGCGCGGCCGCCAGATCTGGCAGAAACGAGCAAAGAAAAGTAAG-3'
ENO1-ydF	5'-ACGCGGCCGCTCTTACGCCACTAAAATCCACGCC-3'
ENO1-ydR	5'-TGCTCGAGCAATTGAGAAGCCTTTTGGAAATCTTTACC-3'
ENO1-LDF	5'-CGGGATCCATGTCTTACGCCACTAAAATCCAC-3'
ENO1-LDR	5'-GCTCTAGATTACAATTGAGAAGCCTTTTGGAAATCTTTACC-3'

3. SDC medium, 2 % (w/v) glucose, 0.67 % (w/v) yeast nitrogen base without amino acids, 1 % (w/v) casamino acids, and supplemented with appropriate amino acids.

2.4 Animals

Female C57BL/6 mice can be obtained from a local supplier. Mice were maintained in a specific-pathogen-free manner and allowed to drink and eat ad libitum.

2.5 Primers

PCR primers used in this study are listed in Table 1.

2.6 Adjuvants

1. Cholera toxin (Sigma-Aldrich, St. Louis, Mo., USA).
2. Freund's incomplete adjuvant (Difco Laboratories, Detroit, MI, USA).

3 Methods

3.1 *E. coli* Plasmid Construction

1. Perform PCR using primers ENO1F and ENO1R and genomic DNA of *C. albicans* strain SC5314 to amplify the *Eno1p* coding sequence.
2. Insert the fragment of the *Eno1p* coding sequence into the pQE30 plasmid digested with *Bam*HI and *Hind*III. The resulting plasmid is referred to as pQE30-eno1 in the following sections (Fig. 4) (*see Note 1*).

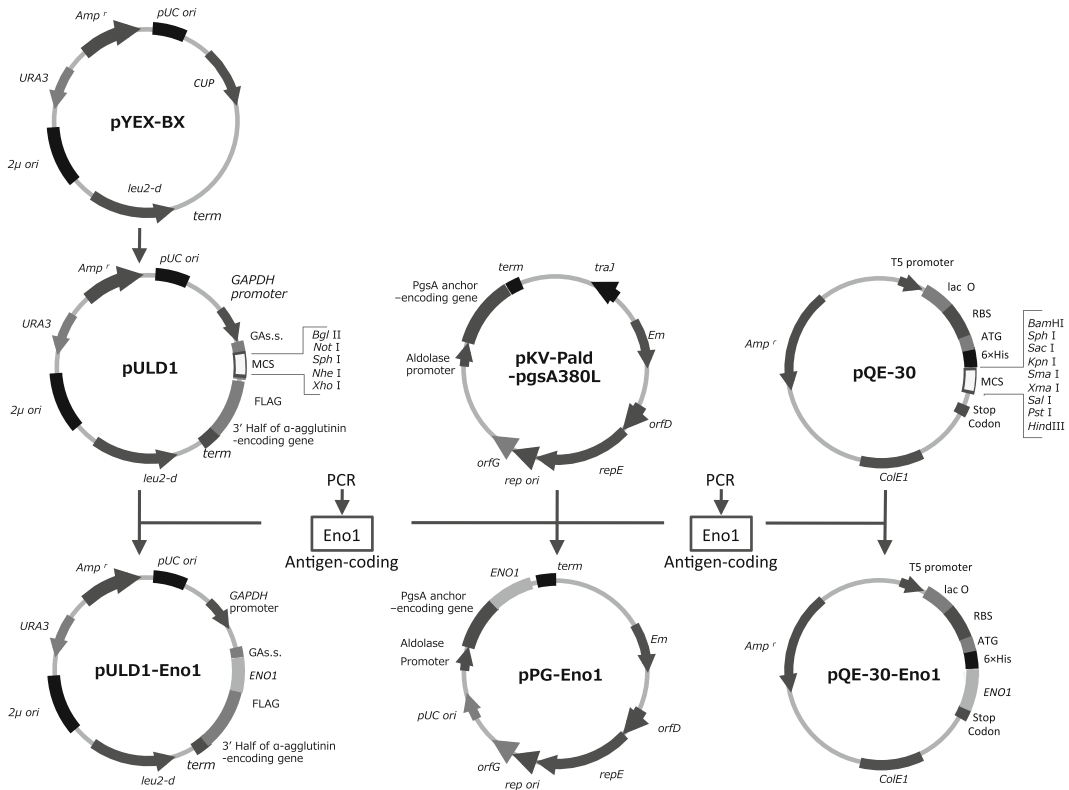

Fig. 4 Plasmid constructions for surface display of antigenic proteins and non-displayed proteins (control). (Left) pULD1-eno1 for *S. cerevisiae*. (Middle) pPG-eno1 for *L. casei*. (Right) pQE30-eno1 for *E. coli*

3.2 Protein Production and Purification (Non-displayed Protein for Control Experiments)

1. Introduce the pQE30-eno1 plasmid into *E. coli* strain BL21 (DE3) for the production of Eno1p as a fusion protein with an N-terminal His6 tag [26].
2. Inoculate the cells in 14 mL of LB medium, containing 100 mg/L ampicillin, and grown in shaking flasks overnight at 37 °C.
3. Inoculate 6 mL of the overnight cultures into fresh LB medium containing 100 mg/L ampicillin (120 mL) and incubate the cells at 37 °C until $OD_{600} = 0.6-1.0$.
4. Induce gene expression by the addition of isopropyl β -D-thiogalactoside (IPTG; Wako Pure Chemical, Osaka, Japan) to a final concentration of 1 mM.
5. After 3–4 h of cultivation at 37 °C, harvest the cell cultures by centrifugation ($4000 \times g$, 20 min, 4 °C).
6. Resuspend the cell pellets in 10 mL of Bacterial Protein Extraction Reagent (B-PER; Thermo Fisher Scientific, Rockford, IL, USA), and shake gently for 10 min at room temperature (25 °C).

7. Separate soluble proteins from insoluble proteins by centrifugation at $27,000 \times g$ for 20 min.
8. Before purification, maintain the supernatant containing soluble proteins on ice.
9. Equilibrate the nickel-chelated agarose column (Thermo Fisher Scientific) with 10 mL of B-PER and apply the supernatant.
10. After washing the column of the B-PER with wash buffer, release the bound proteins with elution buffer (50 mM Tris, 300 mM NaCl, 200 mM imidazole, and 10 % (v/v) glycerol).
11. Remove endotoxins from the eluate by passage through Detoxi-Gel endotoxin-removing columns (Pierce, Rockford, IL, USA) to <0.1 endotoxin units/mL, as indicated using limulus amoebocyte lysate (LAL) PYROGENT single-test vials (Lonza, Walkersville, MD, USA) following the manufacturer's protocol (*see* **Notes 2** and **3**).

3.3 Yeast Plasmid Construction

1. Amplify the DNA sequences of the *GAPDH* promoter and the terminator of pWGP3 [27] by PCR using the primers GAP-PF and GAP-TR.
2. Insert the amplified fragment into the *HindIII*–*KpnI* section of pYEX-BX containing the *leu2-d* marker. Perform plasmid cloning using *E. coli* DH5 α cells.
3. Prepare the DNA fragment encoding the secretion signal of glucoamylase from *Rhizopus oryzae* and the multicloning site by annealing and extension with DNA polymerase with the primers MCS-F and MCS-R.
4. Introduce the prepared DNA fragment into the *EcoRI*–*KpnI* section of the plasmid.
5. Insert the *XhoI*–*KpnI* fragment of pMWFD encoding the FLAG tag [28] and the 320 C-terminal amino acids of α -agglutinin. The high-copy-number cassette vector for cell surface display is referred to as pULD1 in the following sections (Fig. 4) [29].
6. To construct the pULD-*eno1* plasmid from pULD1, amplify the *Eno1p* coding sequence by PCR using the primers ENO1-ydF and ENO1-ydR and the genomic DNA of *C. albicans*.
7. Insert the fragment of the gene encoding *ENO1* into the pULD1 plasmid digested with *NotI* and *XhoI*. The resulting plasmid is referred to as pULD-*eno1* in the following sections.
8. Confirm the nucleotide sequence of all constructed plasmids using an ABI PRISM 3130 Genetic Analyzer (Applied Biosystems, Foster City, CA, USA).

9. Introduce the pULD1-*eno1* plasmid and parent pULD1 plasmid into *S. cerevisiae* BY4741 using the lithium acetate method [30] for surface display of the antigenic protein Eno1p.
10. Select the cells harboring these plasmids using uracil-deficient SDC (SDC-ura) medium.

3.4 *L. casei* Plasmid Construction

1. Propagate the *C. albicans* Eno1p-encoding pULD1-*eno1* plasmid [3] in *E. coli*.
2. Amplify the *ENO1* gene by PCR with the following two primers: ENO1-LDF and ENO1-LDR.
3. Insert the *ENO1* PCR product into pKV-Pald-pgsA380L using the *Bam*HI and *Xba*I restriction sites (Fig. 4) [5]. The resulting plasmid is referred to as pPG-*eno1* in the following sections.
4. Confirm the nucleotide sequence of this construct using an ABI PRISM 3130 Genetic Analyzer (Applied Biosystems).
5. Introduce the constructed plasmid (pPG-*eno1*) into *L. casei* 525 using the previously described electroporation protocol for microorganisms [5].

3.5 Immuno- fluorescence Staining to Verify Surface Display

1. Select a colony of cells harboring a plasmid for an antigenic protein on the cell surface and place it in SDC-ura liquid medium.
2. Cultivate cells in SDC-ura liquid medium at 30 °C overnight.
3. Collect yeast cells by centrifugation at 6000 × *g* for 5 min.
4. Wash the cell pellet with phosphate-buffered saline (PBS; 50 mM phosphate, 150 mM sodium chloride, pH 7.4) and adjust the volume to 3.2 × 10⁸ cells/mL with PBS.
5. Centrifuge 200 μL of this cell suspension at 6000 × *g* for 5 min.
6. Collect cells and incubate with 200 μL of a 1:250 dilution of rabbit immunoglobulin G (IgG) in PBS containing 1 % (w/v) BSA at room temperature for 1 h (*see Note 4*).
7. Incubate surface-blocked cells with 3 μg/mL of mouse monoclonal antibody against the FLAG tag (Sigma-Aldrich, MO, USA) in PBS for 1.5 h at room temperature.
8. After washing with PBS, incubate the cells with 3 μg/mL of Alexa Fluor 488-conjugated goat anti-mouse IgG antibody (Invitrogen, Carlsbad, CA, USA) in PBS for 1.5 h at room temperature, and then wash again.
9. Observe the fluorescence of the yeast cell surface using an Olympus BX51 microscope (Olympus, Tokyo, Japan) (Fig. 5).
10. Measure the fluorescence units using the SpectraMax M2 microplate reader (Molecular Devices, Sunnyvale, CA, USA) with excitation and emission wavelengths of 495 nm and 519 nm, respectively.

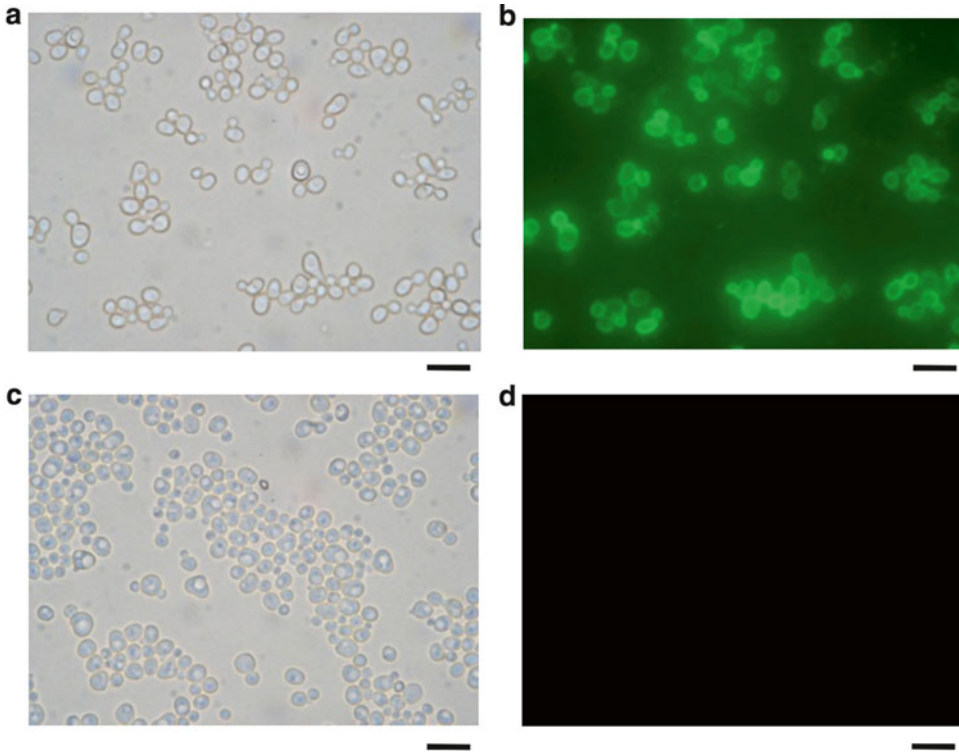

Fig. 5 Immunofluorescence microscopy of antigen-displaying cells. **(a and b)** *S. cerevisiae* BY4741 harboring pULD1-eno1. **(c and d)** *S. cerevisiae* BY4741 (control cell). **(a and c)** Bright-field images. **(b and d)** Fluorescence microscopic images after staining using the anti-FLAG antibody. Scale bars = 10 μm

3.6 Immunization by Intranasal or Subcutaneous Administration Using Recombinant Proteins (Control Experiments)

1. Immunize 7-week-old female C57BL/6 mice with 30 μg of *E. coli*-expressed recombinant Eno1 protein by intranasal delivery (i.n.) or subcutaneous injection (s.c.), using 20- μL volumes containing 1 μg cholera toxin (i.n.) or 100- μL volumes containing Freund's incomplete adjuvant (s.c.).
2. Prepare 7-week-old female C57BL/6 mice for immunization experiments.
3. Immunize mice at weeks 0, 2, and 4. Blood samples should be collected at week 6 from the tail vein to determine the titer of serum IgG that binds to Eno1p.
4. For survival studies, infect mice with 1.1×10^5 cells of *C. albicans* resuspended in 100 μL of PBS by tail-vein injection 2 weeks after the last immunization.
5. Observe mice daily for several weeks after challenge (*see Note 5*).

3.7 Oral Administration of Cells Displaying Eno1p and Challenge with *C. albicans*

1. Select a colony of cells harboring a plasmid for an antigenic protein on the cell surface and place it in SDC-ura liquid medium.
2. Cultivate cells in SDC-ura liquid medium at 30 °C overnight.
3. Take 1 mL of cultivated liquid medium and pour it into fresh SDC-ura liquid medium. Cultivate cells at 30 °C overnight.
4. Collect yeast cells by centrifugation at $6000 \times g$ for 5 min.
5. Wash the cell pellet with PBS and store at 4 °C until administration.
6. Prepare 7-week-old female C57BL/6 mice for immunization experiments.
7. Adjust the concentration of *S. cerevisiae* or *L. casei* cells displaying Eno1p on their surfaces to 1.6×10^9 cells in 400 mL using PBS. Use wild-type *S. cerevisiae* as a control.
8. Administer solutions to mice at weeks 0, 1, and 3 (priming) and at week 7 (booster). Suspend all inoculums in PBS (400 μ L per animal) and administer via an intragastric tube after 2 h of fasting, once per day, 5 days per week.
9. Collect blood samples at week 9 from the tail vein to determine the titer of serum IgG.
10. For survival studies, infect mice with 1.1×10^5 cells of *C. albicans* resuspended in 100 μ L of PBS by tail-vein injection 2 weeks after the final immunization.
11. Observe mice daily for several weeks after challenge (*see Note 5*).

3.8 Determination of Endpoint Titer

1. Conduct indirect enzyme-linked immunosorbent assay (ELISA) for antibody analysis for antisera collected at week 6 (i.n. or s.c.) or week 9 (p.o.). Briefly, coat 96-well microtiter plates (Nalge Nunc International, Rochester, NY, USA) with 50 μ L/well *E. coli*-expressed recombinant Eno1 (0.01 μ g/ μ L).
2. Block the plates with 1 % BSA dissolved in PBS containing 0.05 % Tween-20. Serially dilute antisera and horseradish peroxidase (HRP)-conjugated goat anti-mouse IgG (1/4000, Promega, Madison, WI, USA) and its substrate, which will be added to the wells.
3. After 20 min incubation at room temperature, stop the reaction by adding 1 M sulfuric acid, and measure the absorbance at 450 nm (OD_{450}) using a microplate reader (Bio-Rad Laboratories Inc., Redmond, WA, USA) (*see Note 6*).

4 Notes

1. Confirm the nucleotide sequence of the insert within the pQE vector by comparison with the *Candida* genome database (<http://www.candidagenome.org/>).
2. The endotoxin concentration in the eluate from the nickel-chelated column ranged from 0.06 to 0.125 EU (endotoxin units)/mL.
3. Analyze the antigenic proteins using sodium dodecyl sulfate-polyacrylamide gel electrophoresis and Western blotting to verify that anti-His antibody recognized the purified protein.
4. Use a rotation mixer for an efficient reaction between the displayed protein and IgG. To reduce nonspecific binding of IgG to the cell surface, the incubation can be prolonged overnight at 4 °C [31].
5. The outcomes of the *C. albicans* challenge can be analyzed using the Kaplan–Meier method. Significant differences between groups can be tested using the log-rank method [3].
6. The serum IgG antibody titer was defined as the serum dilution that gave an OD₄₅₀ value equal to 0.1.

Acknowledgements

We thank Miki Karasaki for the preparation of figures. This chapter described the work supported by the regional innovation creation R&D programs of the Ministry of Economy, Trade and Industry, Japan (22R5005).

References

1. Kwon KC, Verma D, Singh ND, Herzog R, Daniell H (2013) Oral delivery of human bio-pharmaceuticals, autoantigens and vaccine antigens bioencapsulated in plant cells. *Adv Drug Deliv Rev* 65:782–799
2. Tsiang H (1998) Rabies vaccines: a review of progress towards improved efficacy and safety. *BioDrugs* 10:317–328
3. Shibasaki S, Aoki W, Nomura T, Miyoshi A, Tafuku S, Sewaki T, Ueda M (2013) An oral vaccine against candidiasis generated by a yeast molecular display system. *Pathog Dis* 69: 262–268
4. Shibasaki S, Aoki W, Ueda M (2013) Biochemical analysis and application of molecular display technology on *Candida albicans* for diagnosing and preventing candidiasis. *Yakugaku Zasshi* 133:1145–1151
5. Shibasaki S, Karasaki M, Tafuku S, Aoki W, Sewaki T, Ueda M (2014) Oral immunization against candidiasis using *Lactobacillus casei* displaying Enolase 1 from *Candida albicans*. *Sci Pharm* 82:697–708
6. Shibasaki S, Karasaki M, Ueda M (2014) Combining proteomic strategies and molecular display technology for development of vaccines against *Candida albicans*. *J Proteomics Bioinform* 7:134–138
7. Ståhl S, Robert A, Gunneriusson E, Wernerus H, Cano F, Liljeqvist S, Hansson M, Nguyen TN, Samuelson P (2000) Staphylococcal surface display and its applications. *Int J Med Microbiol* 290:571–577
8. Narita J, Okano K, Kitao T, Ishida S, Sewaki T, Sung MH, Fukuda H, Kondo A (2006) Display of alpha-amylase on the surface of *Lactobacillus*

- casei* cells by use of the PgsA anchor protein, and production of lactic acid from starch. Appl Environ Microbiol 72:269–275
9. Piard JC, Hautefort I, Fischetti VA, Ehrlich SD, Fons M, Gruss A (1997) Cell wall anchoring of the *Streptococcus pyogenes* M6 protein in various lactic acid bacteria. J Bacteriol 179:3068–3072
 10. Shibasaki S, Ueda M (2014) Bioadsorption strategies with yeast molecular display technology. Biocontrol Sci 19:157–164
 11. Shibasaki S, Maeda H, Ueda M (2009) Molecular display technology using yeast-arming technology. Anal Sci 25:41–49
 12. Adachi K, Kawana K, Yokoyama T, Fujii T, Tomio A et al (2010) Oral immunization with a *Lactobacillus casei* vaccine expressing human papillomavirus (HPV) type 16 E7 is an effective strategy to induce mucosal cytotoxic lymphocytes against HPV16 E7. Vaccine 28:2810–2817
 13. Kondo A, Ueda M (2004) Yeast cell-surface display--applications of molecular display. Appl Microbiol Biotechnol 64:28–40
 14. Cappellaro C, Hauser K, Mrsa V, Watzele M, Watzele G, Gruber C, Tanner W (1991) *Saccharomyces cerevisiae* α - and α -agglutinin: characterization of their molecular interaction. EMBO J 10:4081–4088
 15. Berner VK, Sura ME, Hunter KW Jr (2008) Conjugation of protein antigen to microparticulate beta-glucan from *Saccharomyces cerevisiae*: a new adjuvant for intradermal and oral immunizations. Appl Microbiol Biotechnol 80:1053–1061
 16. Pouwels PH, Leer RJ, Shaw M, Heijne den Bak-Glashouwer MJ et al (1998) Lactic acid bacteria as antigen delivery vehicles for oral immunization purposes. Int J Food Microbiol 41:155–167
 17. Turner MS, Giffard PM (1999) Expression of Chlamydia psittaci- and human immunodeficiency virus-derived antigens on the cell surface of *Lactobacillus fermentum* BR11 as fusions to BspA. Infect Immun 67:5486–5489
 18. TurnerMS HLM, Walsh T, Giffard PM (2003) Peptide surface display and secretion using two LPXTG-containing surface proteins from *Lactobacillus fermentum* BR11. Appl Environ Microbiol 69:5855–5863
 19. Mazmanian SK, Ton-That H, Schneewind O (2001) Sortase-catalysed anchoring of surface proteins to the cell wall of *Staphylococcus aureus*. Mol Microbiol 40:1049–1057
 20. Ashiuchi M, Misono H (2002) Biochemistry and molecular genetics of poly- γ -glutamate synthesis. Appl Microbiol Biotechnol 59:9–14
 21. Leenhouts K, Buist G, Kok J (1999) Anchoring of proteins to lactic acid bacteria. Antonie Van Leeuwenhoek 76:367–376
 22. Pfaller MA, Diekema DJ (2007) Epidemiology of invasive candidiasis: a persistent public health problem. Clin Microbiol Rev 20:133–163
 23. Rodloff C, Koch D, Schaumann R (2011) Epidemiology and antifungal resistance in invasive candidiasis. Eur J Med Res 16:187–195
 24. Montagnoli C, Sandini S, Bacci A, Romani L, La Valle R (2004) Immunogenicity and protective effect of recombinant enolase of *Candida albicans* in a murine model of systemic candidiasis. Med Mycol 42:319–324
 25. Xin H, Cutler JE (2011) Vaccine and monoclonal antibody that enhance mouse resistance to candidiasis. Clin Vaccine Immunol 18:1656–1667
 26. Hanahan D (1983) Studies on transformation of *Escherichia coli* with plasmids. J Mol Biol 166:557–580
 27. Takahashi S, Ueda M, Tanaka A (2001) Function of the prosequence for *in vivo* folding and secretion of active *Rhizopus oryzae* lipase in *Saccharomyces cerevisiae*. Appl Microbiol Biotechnol 55:454–462
 28. Hopp TP, Prickett KS, Price VL, Libby RT et al (1988) A short polypeptide marker sequence useful for recombinant protein identification and purification. Nat Biotechnol 6:1204–1210
 29. Kuroda K, Matsui K, Higuchi S, Kotaka A, Sahara H, Hata Y, Ueda M (2009) Enhancement of display efficiency in yeast display system by vector engineering and gene disruption. Appl Microbiol Biotechnol 82:713–719
 30. Ito H, Fukuda Y, Murata K, Kimura A (1983) Transformation of intact yeast cells treated with alkali cations. J Bacteriol 153:163–168
 31. Shibasaki S, Kawabata A, Ishii J, Yagi S et al (2007) Construction of a novel synergistic system for production and recovery of secreted recombinant proteins by the cell surface engineering. Appl Microbiol Biotechnol 75:821–828

Chapter 33

Facile Method for the Production of Recombinant Cholera Toxin B Subunit in *E. coli*

Krystal Hamorsky and Nobuyuki Matoba

1 Introduction

CTB is the nontoxic subunit of cholera holotoxin. The protein forms stand-alone, stable homopentamers with a molecular mass of about 55 kDa [1]. Bacterially produced recombinant CTB is currently used as an active component of internationally licensed, World Health Organization-prequalified oral cholera vaccine (Dukoral®, Crucell) to induce holotoxin-neutralizing antibodies in the gut [2]. CTB is a strong vaccine adjuvant and has been used as a scaffold for vaccine development against bacterial and viral pathogens (reviewed in ref. 3). In addition, studies have revealed that CTB induces anti-inflammatory responses and suppresses immunopathological reactions in allergy and autoimmune diseases (reviewed in ref. 3). Commercially available nonrecombinant CTB contains trace amounts of cholera toxin and cholera toxin A subunit [4], which can influence the biological activity of CTB [3]. Therefore, high-quality recombinant CTB is necessary for immunological research.

We have developed a simple *E. coli*-based expression and two-step purification scheme to produce high-purity recombinant CTB. The pET expression system was used for CTB expression. pET-22b(+) expression vector contains the T7 promoter which is known to drive high expression levels of recombinant proteins. Moreover, pET-22b(+) contains the N-terminal *pelB* leader sequence to target recombinant proteins to the periplasm. In this case, CTB was secreted into the bacterial culture medium, allowing for facile isolation and purification of the protein. Immobilized metal affinity chromatography (IMAC) and ceramic hydroxyapatite (CHT) chromatography were used to purify CTB. CTB is known to bind to immobilized Ni²⁺ ions through internal histidine residues

[5]; therefore, CTB can be purified to high purity using IMAC. CHT is a multimodal resin that utilizes cation exchange and metal affinity and is known to offer unique selectivity and often separates biomolecules that appear homogenous using other chromatographic methods. Furthermore, CHT aids in removing non-proteinous contaminants such as DNA and endotoxins.

The expression and purification scheme described herein allows for an easy and efficient way to manufacture recombinant CTB, which may facilitate immunological research and vaccine development.

2 Materials

Prepare all solutions using ultrapure Milli-Q water (Milli-Q Synthesis, Millipore, 18.2 M Ω cm at 25 °C) and analytical grade reagents. Prepare and store all reagents at room temperature (unless indicated otherwise). CTB purified product is stored at 4 °C until use.

2.1 CTB Expression

1. pET22b-CTB: pET-22b(+) (Novagen) vector containing the coding sequence for *Vibrio cholerae* CTB gene (GenBank accession no. AAC34728) (obtained via standard molecular biology/subcloning procedures using *NcoI* and *BlpI* (*see Note 1*) restriction sites (*see Note 2*)).
2. BL21 (DE3) electrocompetent cells.
3. Electroporator.
4. Electroporation cuvettes.
5. Kimwipes.
6. 1.5 mL microcentrifuge tube.
7. Luria–Bertani (LB) agar plates.
8. Incubator (37 °C).
9. LB broth.
10. Ampicillin.
11. 15 mL conical tubes.
12. 1 L baffled flask.
13. Orbital shaker.
14. Spectrophotometer.
15. Isopropyl β -D-1-thiogalactopyranoside (IPTG).

2.2 CTB Isolation

1. 250 mL centrifuge bottles.
2. Centrifuge.
3. 0.22 μ M bottle top filter unit.

2.3 IMAC Purification

1. IMAC Buffer A: 20 mM Tris-HCl, 500 mM sodium chloride, pH 8.0. A stock solution of 0.1 M tris(hydroxymethyl)aminomethane is made by using 12.1 g/L and a stock solution of 0.1 M hydrochloric acid is made by diluting concentrated hydrochloric acid. Mix 100 mL of 0.1 M tris(hydroxymethyl)aminomethane and 54.6 mL of 0.1 M hydrochloric acid. Bring the volume to 400 mL with water to make 50 mM tris buffer. Adjust the pH to 8.0 using 1 M NaOH. Weigh 29.22 g of sodium chloride and transfer it to the cylinder containing 400 mL of 50 mM tris buffer. Add water to a volume of 900 mL. Stir to dissolve. Mix and adjust pH if needed using 1 M HCl. Add water to a volume of 1 L.
2. IMAC Buffer B: 20 mM Tris-HCl, 500 mM sodium chloride, 150 mM imidazole, pH 8.0. A stock solution of 0.1 M tris(hydroxymethyl)aminomethane is made by using 12.1 g/L and a stock solution of 0.1 M hydrochloric acid is made by diluting concentrated hydrochloric acid. Mix 100 mL of 0.1 M tris(hydroxymethyl)aminomethane and 54.6 mL of 0.1 M hydrochloric acid. Add water to 400 mL to make 50 mM tris buffer. Adjust the pH to 8.0 using 1 M NaOH. Weigh 29.22 g of sodium chloride and 10.2 g of imidazole and transfer them to the cylinder containing 400 mL of 50 mM tris buffer. Add water to a volume of 900 mL. Stir to dissolve. Mix and adjust pH using 1 M HCl if needed. Add water to 1 L.
3. AKTA purifier 100 liquid chromatography system (GE Healthcare Life Sciences), or similar.
4. Talon[®] Superflow Metal Affinity Resin (Clontech).
5. XK 26/20 column (GE Healthcare Life Sciences).
6. 15 % Tris-Glycine gels (Lonza) and materials for sodium dodecyl sulfate polyacrylamide gel electrophoresis (SDS-PAGE).

2.4 CHT Purification

1. CHT Buffer A: 10 mM Tris-HCl, 5 mM sodium phosphate, pH 8.0. A stock solution of 0.1 M tris(hydroxymethyl)aminomethane is made by using 12.1 g/L and a stock solution of 0.1 M hydrochloric acid is made by diluting concentrated hydrochloric acid. Mix 100 mL of 0.1 M tris(hydroxymethyl)aminomethane and 54.6 mL of 0.1 M hydrochloric acid. Add water to 400 mL to make 50 mM tris buffer. Adjust the pH to 8.0 using 1 M NaOH. A stock solution of 0.1 M sodium phosphate monobasic is made using 13.8 g/L and a stock solution of 0.1 M sodium phosphate dibasic (heptahydrate) is made using 26.8 g/L. Mix 5.3 mL of sodium phosphate monobasic and 94.7 mL of sodium phosphate dibasic. Add water to 200 mL to make 50 mM phosphate buffer. Adjust the pH to 8.0 using 1 M HCl. In a cylinder, mix 200 mL of 50 mM Tris-HCl with 100 mL of 50 mM phosphate buffer. Add water to a volume of 900 mL. Mix and adjust pH if needed using 1 M NaOH. Add water to 1 L.
2. CHT Buffer B: 10 mM Tris-HCl, 500 mM sodium phosphate, pH 8.0. A stock solution of 0.1 M tris(hydroxymethyl)amino-

methane is made by using 12.1 g/L and a stock solution of 0.1 M hydrochloric acid is made by diluting concentrated hydrochloric acid. Mix 100 mL of 0.1 M tris(hydroxymethyl)aminomethane and 54.6 mL of 0.1 M hydrochloric acid. Add water to 400 mL to make 50 mM tris buffer. Adjust the pH to 8.0 using 1 M NaOH. A stock solution of 1 M sodium phosphate monobasic is made using 138 g/L and a stock solution of 1 M sodium phosphate dibasic (heptahydrate) is made using 268 g/L (*see Note 3*). Mix 26.5 mL of sodium phosphate monobasic and 473.5 mL of sodium phosphate dibasic to make 1.0 M phosphate buffer. Adjust pH if needed to 8.0 using 1 M HCl. In a cylinder, mix 200 mL of 50 mM Tris-HCl with 500 mL of 1.0 M phosphate buffer. Add water to a volume of 900 mL. Mix and adjust pH if needed using 1 M NaOH. Add water to 1 L.

3. AKTA purifier 100 liquid chromatography system (GE Healthcare Life Sciences), or similar.
4. CHT™ ceramic hydroxyapatite, Type I, 40 μM (Bio-Rad).
5. XK 16/20 column (GE Healthcare Life Sciences).
6. 15 % Tris-Glycine gels (Lonza) and materials for SDS-PAGE.

2.5 Formulation

1. Dulbecco's Phosphate Buffered Saline (DPBS) without calcium and magnesium.
2. Amicon Ultra centrifugal filter, 30 K (Millipore).
3. 15 % Tris-Glycine gels (Lonza) and materials for denaturing and non-denaturing SDS-PAGE.

3 Methods

3.1 CTB Expression

1. Transform 1 μL of plasmid pET22b-CTB (stock concentration 1 ng/μL) into electrocompetent BL21(DE3) cells. Place electroporation cuvette on ice and allow BL21(DE3) cells (frozen 50 μL aliquots) to thaw on ice. Add 1 μL of plasmid to thawed cells and place in electroporation cuvette. Wipe metal sides of cuvette with Kimwipes. Transform 2000 V for 5 ms. Add 949 mL of LB broth to cuvette, mix, and transfer to autoclaved 1.5 mL microcentrifuge tube. Plate a 1:10 dilution of transformed cells on LB agar plates containing 100 μg/mL ampicillin. Incubate plate overnight in 37 °C incubator.
2. Pick an isolated colony and inoculate in 5 mL LB broth in a 15 mL conical tube with 100 μg/mL ampicillin. Culture overnight (12–16 h) at 37 °C at 250RPM.
3. Inoculate 500 mL of LB broth containing 100 μg/ml ampicillin with 5 mL culture from **step 2**, Subheading **3.1**. Grow 37 °C at 250 RPM. When the culture reaches an OD600 of 0.6–1.0 (*see Note 4*), add IPTG to 0.4 mM final concentration (*see Notes 5 and 6*) and continue to culture for 4 h.

3.2 CTB Isolation

1. Harvest the cells by centrifugation at $15,000\times g$ at $4\text{ }^{\circ}\text{C}$ for 15 min.
2. The culture supernatant (medium) contains CTB (*see Note 7*). Filter supernatant through a $0.2\text{ }\mu\text{m}$ bottle top filter using a house vacuum. The supernatant is now ready for loading onto the IMAC column (*see Note 8*).

3.3 IMAC Purification

1. Pack the Talon Superflow Metal Affinity Resin in an XK 26/20 column to a 10 mL bed volume on an AKTA purifier.
2. Equilibrate the column with 10 column volumes (CV) of IMAC buffer A at 10 mL/min.
3. Load the culture medium (from **step 2**, Subheading **3.2**) at a flow rate of 5.0 mL/min (*see Note 9*) followed by a 10 CV wash with IMAC buffer A at 10 mL/min.
4. Elute proteins using a single step gradient to 100 % IMAC buffer B for 5 CV at 10 mL/min. Collect 10 mL fractions.
5. Analyze each fraction for CTB purity by SDS-PAGE using 15 % Tris-Glycine gels.
6. Combine CTB-containing fractions for CHT purification (*see Note 10* and Fig. 1).

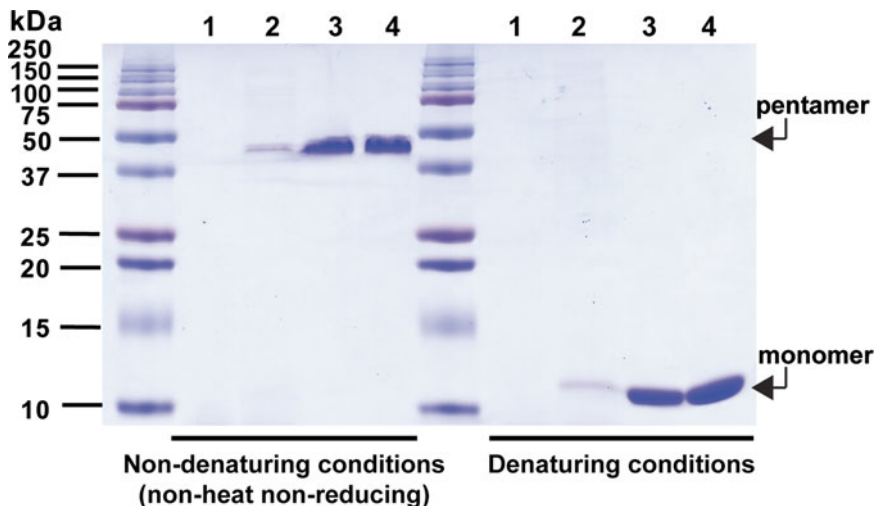

Fig. 1 Expression and purification of CTB. (a) Non-denaturing (*left*) and denaturing (*right*) sodium dodecyl sulfate polyacrylamide gel electrophoresis (SDS-PAGE) analysis. *Lane 1*: Culture medium preinduction (*see Note 6*). *Lane 2*: Culture medium postinduction (*see Note 8*). *Lane 3*: Five microgram of CTB purified by IMAC only. *Lane 4*: Five microgram of CTB purified by IMAC plus CHT (*see Note 11*). CTB retains pentamer formation at around 50 kDa under non-denaturing conditions that is needed for GM1-ganglioside binding and is broken down into monomer at 12.3 kDa under denaturing conditions. CTB was purified to >95 % purity after IMAC only as well as IMAC plus CHT

3.4 CHT Purification

1. Pack the CHT, Type I, 40 μm resin in an XK 16/20 column to a 10 mL bed volume on an AKTA purifier.
2. Equilibrate the column with 10 CV of CHT buffer A at 10 mL/min.
3. Load the CTB IMAC elution (from **step 6**, Subheading **3.3**) at a flow rate of 5.0 mL/min followed by a 10 CV wash with CHT buffer A at 10 mL/min.
4. Elute proteins using a gradient from 0 to 100 % CHT buffer B over 20 CV at 10 mL/min. Collect 10 mL fractions.
5. Analyze each fraction for CTB purity by SDS-PAGE using 15 % Tris-Glycine gels.
6. Combine pure CTB-containing fractions.

3.5 Formulation of CTB

1. Ultrafiltrate and diafiltrate the CTB solution (combined fractions from CHT purification in **step 6**, Subheading **3.4**) into sterile Dulbecco's PBS (DPBS) using Amicon Ultra-15 30000 MWCO centrifugal devices according to the manufacturer's instructions.
2. To determine the concentration of CTB solution, measure the absorbance at 280 nm using UV-Vis spectroscopy. Use DPBS as a blank. Divide the absorbance value by CTB's theoretical extinction coefficient at 280 nm of $0.8181 \text{ (mg/mL)}^{-1} \text{ cm}^{-1}$.
3. Analyze the purity and pentamer formation of purified CTB by use of an overloaded (5 μg) Coomassie-stained SDS-PAGE under denaturing and non-denaturing conditions using 15 % Tris-Glycine gels (*see* **Notes 11, 12, and 13**; Fig. 1).

4 Notes

1. Cloning with *BspI* removes the optional C-terminal hexahistidine-tag sequence. The His-tag is not needed as CTB binds to immobilized Ni^{2+} ions through internal histidine residues [5].
2. DNA sequencing was performed to confirm an in frame *CTB* gene.
3. 1 M dibasic phosphate needs to be made just prior to use to prevent precipitation.
4. Begin checking OD600 approximately 2 h after inoculation.
5. An IPTG concentration of 0.1–1 M is acceptable.
6. Before IPTG is added, set aside 500 μL of culture medium as a preinduction control for SDS-PAGE (*see* Fig. 1). For SDS-PAGE, centrifuge the culture medium at $15,000 \times g$ 1 min. Transfer the media supernatant into a new tube and discard the cell pellet. To 150 μL of media supernatant, add 50 μL of 4 \times non-denaturing (150 mM Tris-HCl, pH 6.8, 40 % glycerol,

0.04 % bromophenyl blue) or 4× denaturing (150 mM Tris–HCl, pH 6.8, 40 % glycerol, 0.04 % bromophenyl blue, 1.6 % SDS, 8 % β-mercaptoethanol) loading dye, heat at 95 °C for 5 min for analysis under denaturing conditions, and load 45 μL on the gel.

7. CTB can also be recovered from the intracellular and periplasmic fractions of *E. coli*, which would provide a higher product yield. However, we purify CTB from the medium only to simplify the process to obtain a high-quality product.
8. Set aside 500 μL of culture medium as a postinduction control for SDS-PAGE (*see* Fig. 1) and GM1-ganglioside capture enzyme-linked immunosorbent assay [6] to determine CTB expression level. For SDS-PAGE, to 150 μL of media supernatant, add 50 μL of 4× non-denaturing (150 mM Tris–HCl, pH 6.8, 40 % glycerol, 0.04 % bromophenyl blue) or 4× denaturing (150 mM Tris–HCl, pH 6.8, 40 % glycerol, 0.04 % bromophenyl blue, 1.6 % SDS, 8 % β-mercaptoethanol) loading dye, heat at 95 °C for 5 min for analysis under denaturing conditions, and load 45 μL on the gel.
9. Although LB broth is not buffered, we found that the IMAC process described here is well tolerated for CTB purification. However, optimization may be necessary for larger-scale production.
10. CTB is purified to >95 % purity after IMAC purification (*see* Fig. 1). CHT was added as a polishing step.
11. For SDS-PAGE analysis, an appropriate volume of 4× non-denaturing or denaturing loading dye (*see* Notes 6 and 8) is added to ~10 μL of CTB solution that contains 5 μg of the protein. Unless heated, CTB in the non-denaturing dye maintains pentamer structure during the electrophoresis in a standard SDS-PAGE procedure.
12. We routinely obtain approximately 12 mg per liter of culture. In addition to SDS-PAGE analysis, GM1-ganglioside-binding affinity can be confirmed using GM1-ganglioside capture enzyme-linked immunosorbent assay or surface plasmon resonance [6].
13. Endotoxin can be removed from purified protein using a commercially available resin for applications that desire endotoxin-free CTB. We have successfully removed endotoxin from CTB to <1 EU/mg with ActiClean Etox (Sterogene Bioseparations) according to the manufacturer's instructions.

Acknowledgements

We thank Lauren J. Moore for technical assistance. This work was supported by DoD/USAMRAA/TATRC/W81XWH-10-2-0082-CLIN2 and the Helmsley Charitable Trust Fund.

References

1. Zhang RG et al (1995) The 2.4 Å crystal structure of cholera toxin B subunit pentamer: cholera toxin B subunit pentamer: cholera toxin B subunit pentamer: cholera toxin B subunit pentamer. *J Mol Biol* 251:550–562
2. Jelinek T, Kollaritsch H (2008) Vaccination with Dukoral against travelers' diarrhea (ETEC) and cholera. *Expert Rev Vaccines* 7:561–567
3. Baldauf KJ et al (2015) Cholera Toxin B: one subunit with many pharmaceutical applications. *Toxins* 7:974–996
4. Tamura S et al (1994) Synergistic action of cholera toxin B subunit (and *Escherichia coli* heat-labile toxin B subunit) and a trace amount of cholera whole toxin as an adjuvant for nasal influenza vaccine. *Vaccine* 12:419–426
5. Dertzbaugh MT, Cox LM (1998) The affinity of cholera toxin for Ni²⁺ ion. *Protein Eng* 11:577–581
6. Hamorsky KT et al (2013) Rapid and scalable plant-based production of a cholera toxin B subunit variant to aid in mass vaccination against cholera outbreaks. *PLoS Negl Trop Dis* 7(3):e2046

Chapter 34

Immunoproteomic Approach for Screening Vaccine Candidates from Bacterial Outer Membrane Proteins

Jianyi Pan, Chuchu Li, and Zhicang Ye

1 Introduction

Gram-negative bacteria have two types of outer membrane proteins (OMPs), lipoproteins, which anchor to the inner leaflet of the outer membrane, and integral OMPs. Integral OMPs are unique to Gram-negative bacteria and adopt a β -barrel architecture with their external sequences exposed to the extracellular environment [1]. These features instill OMPs with essential physiological and virulence functions [2], and OMPs have also been suggested as potential vaccine candidates for conferring protection against infection [3]. The external short sequences of OMPs might act as epitopes to induce specific antibody responses and are thus promising candidates for the development of vaccines. For this reason, in recent years, research has focused on the determination of the immunogenic characteristics of diverse OMPs of diverse bacterial species. For example, in *V. parahaemolyticus*, a model marine bacterium, a few OMPs, such as OmpW and LamB, have been found to be immunogenic and to provide immune protection [4, 5]. These potential vaccine candidates were mainly identified one at a time. For rapid and comprehensive characterization of new vaccine candidates, immunoproteomics, the combination of proteomic technologies and immunological methods, has been proposed [6, 7], and it is now considered to be a powerful technique suitable for the screening and identification of potential vaccine antigens. This chapter outlines the procedure of screening and determination of potential vaccine candidates from OMPs in *V. parahaemolyticus* using an immunoproteomic strategy.

2 Materials

2.1 Bacterial Strains and Plasmids

1. *V. parahaemolyticus* RIMD 2210633, *Escherichia coli* DH5 α , and *E. coli* BL21 (DE3), pET-28a and pET-32a.

2.2 Animals

1. ICR mice with the average weight of 20 g (*see Note 1*).

2.3 Bacterial Culture Medium

1. Luria-Bertani (LB) liquid medium: (1 L) 1 % (w/v) tryptone, 0.5 % (w/v) yeast extract, and 1 % (w/v) NaCl. Weigh 10 g tryptone, 5 g of yeast extract, and 10 g NaCl, and transfer to a 1-L glass baker. Add 950 mL of deionized water to dissolve these materials. Mix the solution and adjust its pH to 7.0 with 1 N NaOH (~1 mL). Adjust the final volume of the solution to 1 L with deionized water. Sterilize the medium by autoclaving it for 20 min at 15 psi (1.05 kg/cm²) on the liquid cycle. If antibiotic is needed, allow the solution to cool to approximately 55 °C, and add ampicillin or kanamycin at a final concentration of 50 μ g/mL. Store at room temperature or 4 °C.
2. LB solid medium: Prepare LB medium as above, but add 15 g/L agar before autoclaving. After autoclaving, cool to approximately 55 °C and add antibiotic (if needed). To prepare plates, pour medium into petri dishes. After hardening, invert and store at 4 °C.
3. High salt medium: LB medium containing 3 % NaCl (*see Note 2*).

2.4 Extraction of OMPs

1. Bacterial cell lysis buffer: 50 mM Tris-HCl, 150 mM NaCl, pH 7.4.
2. SLS buffer: 2 % (w/v) sodium lauroyl sarcosinate (SLS).
3. OMP sample buffer: 8 M urea, 4 % w/v CHAPS, 40 mM Tris base. Store at -20 °C.
4. Protein quantification kit: Pierce™ BCA Protein Assay Kit.

2.5 IEF/SDS Two-Dimensional Electrophoresis (2-DE)

1. Immobilized pH gradient (IPG) strips, pH 3–10 (GE Healthcare).
2. Rehydration buffer: 8 M urea, 2 M thiourea, 4 % (w/v) CHAPS. Store at -20 °C. Prior to use, add 4 mg per mL DTT buffer and 5 μ L per mL-specific IPG buffer (GE Healthcare).
3. Equilibration buffer: 50 mM Tris-HCl, pH 8.8, 6 M urea, 30 % v/v glycerol, 2 % w/v SDS. Add a trace amount of bromophenol blue. Store at -20 °C.
4. Resolving gel buffer: 1.5 M Tris-HCl, pH 8.8. Store at 4 °C.
5. Stacking gel buffer: 0.5 M Tris-HCl, pH 6.8. Store at 4 °C.
6. 30 % acrylamide/bisacrylamide: 29.2 g of acrylamide and 0.8 g bis-methylene-acrylamide dissolved to a final volume of 100 mL with deionized water. Filter through a 0.45 Corning filter (*see Note 3*). Store in the dark at 4 °C.

7. 10 % ammonium persulfate solution (APS): Dissolve 0.1 g of APS (electrophoresis grade) in 1 mL of deionized water (*see Note 4*).
8. 10 % SDS (sodium dodecyl sulfate, electrophoresis grade): Dissolve 5 g of SDS in 45 mL of deionized water with gentle stirring and add deionized water to obtain a final volume of 50 mL. Store at room temperature.
9. 10 % tetramethyl-ethylenediamine (TEMED): Add 100 μ L of TEMED to 900 μ L deionized water. Store at 4 °C.
10. Sample loading buffer (2 \times): 1.2 mL of stacking gel buffer (0.5 M Tris-HCl, pH 6.8), 1 mL of glycerol, 2 mL of 10 % SDS, 0.5 mL of β -mercaptoethanol, 0.3 mL of 1.0 % bromophenol blue. Store at -20 °C.
11. Running buffer: 25 mM Tris-HCl, 192 mM glycine, 0.1 % (w/v) SDS. Store at 4 °C.
12. Staining buffer: Dissolve 1 g of Coomassie blue R-250 in a solution of 400 mL of methanol, 100 mL of acetic acid (glacial), and 500 mL of H₂O. Store at room temperature.
13. Destaining buffer: 400 mL of methanol, 100 mL of acetic acid (glacial), and 500 mL of H₂O. Store at room temperature.

2.6 Dot Enzyme-Linked Immunosorbent Assay (Dot-ELISA) and Western Blotting

1. Nitrocellulose (NC) membrane or polyvinylidene difluoride (PVDF) membrane (*see Note 5*).
2. Transfer buffer: 25 mM Tris, 192 mM glycine, 10 % (v/v) methanol (*see Note 6*).
3. Blocking buffer: 5 % skim milk in TBST or 3 % bovine serum albumin (BSA) in TBST. Store at 4 °C.
4. Tris-buffered saline with Tween-20 buffer (TBST): 20 mM Tris-HCl, pH 7.4, 150 mM NaCl, 0.1 % (v/v) Tween-20. Store at 4 °C.
5. Developing kit: DAB (3,3'-diaminobenzidine) substrate kit. Upon receipt, store kit at 4 °C (*see Note 7*).

2.7 In-Gel Protein Digestion and MALDI-TOF/TOF Mass Spectrometry Analysis

1. Destaining buffer (for gel stained with Coomassie blue): 100 mM ammonium bicarbonate (NH₄HCO₃)/acetonitrile (ACN) (1:1 v/v) (*see Note 8*).
2. Reduction buffer: 10 mM dithiothreitol (DTT) stock (1.5425 mg/mL in 25 mM NH₄HCO₃) (*see Note 9*).
3. Alkylation buffer: 55 mM iodoacetamide (IAA) stock (10.1728 mg/mL in 25 mM NH₄HCO₃). Store in the dark (*see Note 10*).
4. Trypsin solution: Promega sequencing grade-modified trypsin; one vial contains 20 μ g of trypsin. Dissolve one vial in 200 μ L of reconstitution buffer (50 mM acetic acid) to obtain a final

concentration of 100 ng/ μ L. Then, add 90 μ L of 50 mM NH_4HCO_3 to 10 μ L of 100 ng/ μ L trypsin. Store at -80°C .

5. Extraction buffer: (I) 50 % ACN containing 5 % trifluoroacetic acid (TFA); (II) 75 % ACN containing 0.1 % TFA.
6. Peptide sample buffer: 0.1 % TFA in HPLC grade water.
7. Matrix: α -cyano-4-hydroxycinnamic acid (HCCA) in ACN containing 0.1 % TFA.
8. Calibration standard: PepMixII, ProtMixI, or ProtMixII stored at -20°C in aliquots in 0.1 % TFA.

2.8 Cloning, Expression, and Purification

1. Genomic DNA purification buffer: 100 μ L of 50 mM Tris-HCl, pH 8.0, 20 mM EDTA, 0.6 % SDS.
2. Transformation buffer: 50 mM CaCl_2 . Store at 4°C .

2.9 Immunization

1. Complete Freund's adjuvant (CFA) and incomplete Freund's adjuvant (IFA). Store 4°C .

3 Methods

3.1 Preparation of Antiserum against *V. parahaemolyticus*

1. Transfer the overnight culture of *V. parahaemolyticus* RIMD 2210633 to high-salt LB medium and culture at 28°C with shaking.
2. When the culture reaches an OD_{600} of 0.8, harvest the cells by centrifugation at $5000\times g$ for 10 min at 4°C . Wash the cell pellets twice in sterile phosphate-buffered saline (PBS) and resuspend in PBS to a concentration of 2×10^7 CFU/mL.
3. Prepare FKC by the addition of formalin to a final concentration of 0.5 % (v/v) and incubate at 4°C for 24 h [8]. Then, remove formalin by centrifugation at $6000\times g$ for 10 min. Resuspend the resulting cell pellets in PBS and use as antigen to immunize mice.
4. Prepare emulsion by mixing 100 μ L of FKC with 100 μ L CFA (*see Note 11*). Then, inject 200 μ L of the emulsion into ICR mice intraperitoneally. Additionally, inject 200 μ L of PBS into control mice. For each antigen, immunize five mice.
5. Boost injection of mice three times with 200 μ L of the emulsion (100 μ L of FKC mix with 100 μ L IFA) at 7-day intervals. The emulsion is prepared and injected as in **step 4**.
6. Collect blood from mice 7 days after the second boost immunization in a microcentrifuge tube by cutting off 0.5 cm of the tail. Let the blood clot at room temperature for 1 h and store at 4°C overnight. Transfer antiserum to another tube and store at -70°C (*see Notes 12 and 13*).

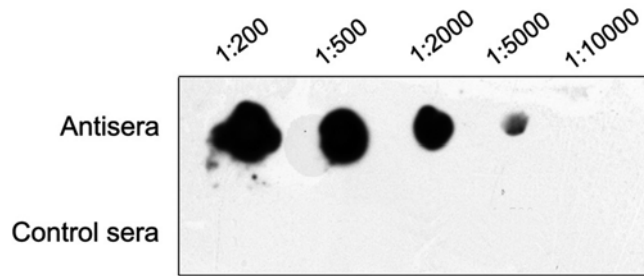

Fig. 1 Determination of the titer of antisera against OMPs by dot-ELISA analysis

7. Determine the antibody titer by dot-ELISA: Prepare an appropriate size NC membrane and soak in transfer buffer. Place NC membrane on a Whatman filter paper. Add 1 μL of the OMP sample carefully (*see Note 14*) as a dot on the center of each pane and incubate for 1 h. Block the membrane for at least 1 h with blocking buffer. After blocking the membrane, add 1 μL of serially diluted antiserum on the center of each pane and incubate for 2 h. Wash membrane three times with TBST buffer, and then, incubate with horseradish peroxidase-conjugated anti-mouse antibody (secondary antibody) for 2 h. Remove the secondary antibody and rinse membrane with TBST buffer three times. Display the protein spot using a DAB developing kit (Fig. 1) (*see Note 15*).

3.2 Screening Immunogenic OMPs

1. Isolation of OMPs of *V. parahaemolyticus* by SLS methods [9]: Culture and collect bacterial cells as described in Subheading 3.1. Wash cells with 50 mM Tris-HCl, pH 7.4, and then, centrifuge at $5000\times g$ for 10 min at 4 °C. Resuspend cell pellets in lysis buffer and break cells by ultrasonication in an ice bath. Subsequently, remove cell debris and unbroken cells by centrifugation at $12,000\times g$ for 10 min at 4 °C. Collect supernatants, and ultracentrifuge them at $100,000\times g$ for 1 h at 4 °C. Resuspend the pellets in SLS buffer, and incubate them at room temperature for 40 min. Ultracentrifuge the resuspended cells under the same conditions. Remove the supernatants. Wash the protein pellets in 25 mM Tris-HCl, pH 7.4, to remove residual detergent, and centrifuge them at $25,000\times g$ for 30 min at 4 °C. The resulting pellets consist of OMPs. Store at -70 °C until use.
2. Resuspend the OMP sample in rehydration buffer. Remove insoluble materials by centrifugation at $13,000\times g$ for 10 min. Then, collect the supernatant containing soluble OMPs and quantify the protein content by BCA assay kit.
3. Use IPGphor isoelectric focusing system (GE Healthcare) employing the Immobiline DryStrips (pH 3–10) to separate the OMP sample with five phases of stepped voltages from 200 to 8000 V. Separate two aliquots of OMPs with two strips simultaneously. Load 50 μg of OMPs onto each strip.

4. Following isoelectric focusing, reduce and bind SDS to OMPs by equilibrating two strips for 15 min in equilibration buffer with gentle shaking.
5. Place two equilibrated strips on 12 % (v/v) SDS-PAGE gels (*see Note 16*), and run the gels under the standard procedure. When the electrophoresis is finished, soak the gels in staining buffer to visualize the protein spots and use another gel for subsequent western blotting analysis.
6. For the western blotting analysis, transfer OMPs from a gel to a PVDF or NC membrane in transfer buffer at 100 V for 1 h under cold conditions (*see Note 17*). Then, block the PVDF membrane with blocking buffer for 2 h at room temperature, or overnight at 4 °C, with shaking.
7. Rinse the membrane three times, 10 min each time, in TBST after blocking. Then, incubate the membrane with mouse antibodies in TBST for 2 h at room temperature, or overnight at 4 °C, with shaking (*see Note 18*). Rinse the membrane three times, 10 min each time, in TBST, and then, incubate the membrane with anti-mouse secondary antibodies at a dilution of 1:1000 for 1 h at room temperature. After incubation, rinse the membrane three times, 10 min each time, with TBST.
8. Prepare 5 mL of DAB substrate working solution according to the DAB Substrate Kit manual (*see Note 19*). Pour the DAB solution over the membrane, and incubate the membrane at room temperature with gentle shaking (*see Note 20*). When protein spots are of the desired intensity (Fig. 2), rinse the membrane in water.

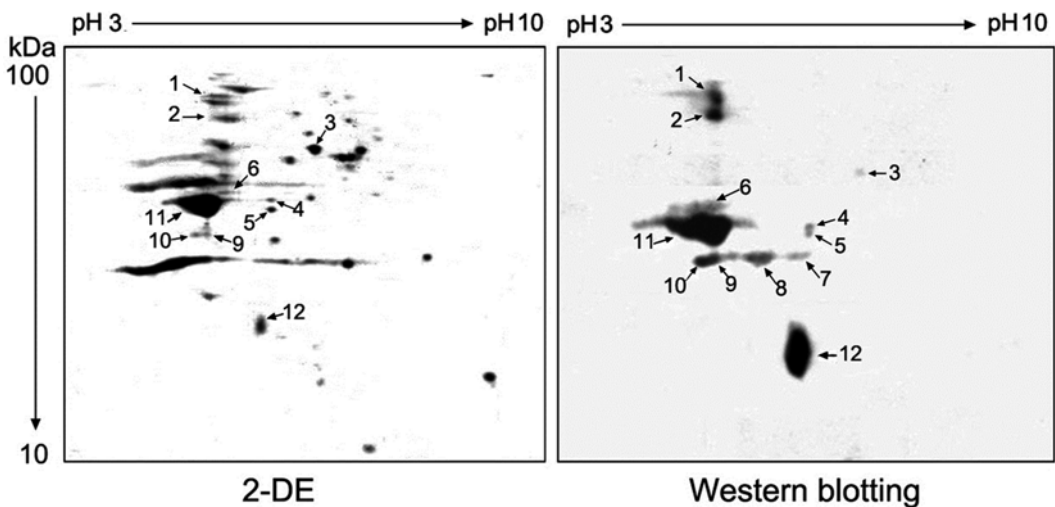

Fig. 2 Screening of immunogenic OMPs from *V. parahaemolyticus* via an immunoproteomic method based on 2-D electrophoresis and immunoblotting analysis. OMPs in the 2-DE gels were transferred onto the NC membrane and incubated with antisera, which were prepared by injection of FKC of *V. parahaemolyticus*

9. Finely excise the gel spots in the 2-DE gel that correspond to the visualized spots on the NC membrane, and cut the gel pieces into 1 mm, or much smaller, cubes (*see Note 21*). Wash the gel pieces by incubating them in 300 μL of destaining buffer for 15 min with vortexing. If the pieces are still stained, repeat the wash step. Dehydrate the gel pieces by adding 200 μL of ACN and incubate them for 5 min with vortexing until the gel pieces become white and shrunken. Dry the gel pieces in a SpeedVac for 20 min.
10. Add 200 μL (or enough to cover the gel pieces) of freshly prepared reduction buffer to the dry gel pieces, and incubate them for 30 min at 56 °C with shaking. Remove the supernatant and add 200 μL of alkylation buffer. Incubate the gel pieces for 30 min at room temperature in the dark with shaking (*see Note 22*). Wash the gel pieces with 300 μL of 25 mM NH_4HCO_3 for 15 min. Then, wash gel pieces with 300 μL of 25 mM NH_4HCO_3 /ACN (1:1 v/v) for 15 min. Dehydrate the gel pieces for 5 min by incubation with 100 μL ACN. Dry the gel pieces in a SpeedVac for 20 min.
11. Rehydrate the gel pieces with 5–10 μL of trypsin solution (*see Note 23*) for 30 min at 4 °C or in an ice bath. The gel pieces will swell and turn clear. If all of the solution was absorbed, add more 50 mM NH_4HCO_3 to cover all of the gel pieces. Then, incubate the gel pieces at 37 °C overnight (12–15 h) with shaking.
12. After digestion, add 25–50 μL of extraction buffer (I) and shake for 5 min. Spin down the solution and transfer the supernatant to a clean tube (0.6 mL). Then, add 25–50 μL of extraction buffer (II) and shake for 5 min. Transfer the supernatant to the same clean tube and dry it in a SpeedVac until obtaining complete dryness. Dried peptide extracts can be stored at –20 °C until use.
13. Add 2 μL of peptide sample buffer to the dried peptides and vortex and spin down the solution. Spot 0.3 μL of the peptide solution on a spot well of a steel target plate. Overlay the spot with 0.3 μL HCCA matrix solution. Spot 0.3 μL of calibration solution in the calibration wells of the steel target plate. Allow samples to air dry completely.
14. Load the steel target plate into a MALDI-TOF tandem mass spectrometer (4700 Proteomics Analyzer, Applied Biosystems) to acquire the mass spectra of the peptides. Submit the obtained MS and MS/MS spectra for a database search using GPSTM Explorer software equipped with the MASCOT search engine to identify proteins. Use search parameters that allow for one missing tryptic cleavage site, the carbamidomethylation of cysteine, and the possible oxidation of methionine, and use a precursor ion mass tolerance of 50 ppm.

3.3 Protective Efficacy Assay

Select an immunogenic OMP of VP0802 [11] to evaluate its protective effect using gene cloning, protein expression and purification, immunization, and an active protection assay:

1. Design and synthesize a pair of primers (forward primer: 5'-ATTCCATATGATGGACAAATTTTTTAAGGT-3'; reverse primer: 5'-CCGCTCGAGTTAGTGGAAGCTGTAAGG-3' (underlined sequences are restriction enzyme sites of NdeI and XhoI, respectively)), and use them to amplify the DNA fragment of *VP0802* by PCR in a 50- μ L reaction system. Purify the PCR products with a PCR purification kit from Qiagen.
2. Digest the PCR products and plasmid pET28a(+) with two restriction enzymes (NdeI and XhoI) in 50 μ L of digestion solution for 2.5 h at 37 °C. After purification of these two degradation derivatives, ligate them in ligation buffer with cells. Plate the bacteria on agar LB containing 50 μ g/mL kanamycin to select the positive recombinant transformants.
3. Culture the positive bacteria in LB medium containing kanamycin (50 μ g/mL), and then extract the recombinant plasmids. After checking by restriction endonuclease digestion and sequencing, the recombinant plasmids are transformed into *E. coli* BL21(DE3).
4. Culture the resulting bacteria (harboring recombinant plasmids) overnight. Add the overnight cultures (1:100 v/v) into fresh LB with kanamycin, and then culture at 37 °C until the absorbent OD₆₀₀ reaches 0.4. Add isopropyl β -D-1-thiogalactopyranoside (IPTG) at a final concentration of 1 mM into cultures to induce expression of VP0802, and continue to culture for 4 h.
5. Harvest bacterial cells by centrifugation. Resuspend cells in 50 mM PBS (pH 8.0) containing 8 M urea, and then break cells by sonication in an ice bath. Remove cell debris by centrifugation at 12,000 $\times g$ for 20 min at 4 °C. Load the resulting supernatant onto a column packed with Ni²⁺-NTA (Qiagen), and purify the target protein by affinity chromatography according to the manufacturer's instructions. Then, determine the concentration of purified proteins by BCA method.
6. Prepare emulsion by mixing 50 μ g of purified VP0802 and complete Freund's adjuvant, as described in Subheading 3.1. Inject the emulsion into an ICR mouse intraperitoneally for an active protection assay, and inject the same volume of PBS into mice for a control. At least five mice are needed for injection in each of the experimental and control groups. Additionally, boost injection of the emulsion (20 μ g of purified protein mix with IFA) at 7-day intervals into mice 2–4 times, as described in Subheading 3.1.

7. Collect 50 μL of serum from each mouse on the seventh day after the final injection and determine the antiserum titer via dot-ELISA, as described in Subheading 3.1.
8. Challenge both groups of mice i.p. with the 2.5×10^7 CFU of *V. parahaemolyticus* in the 14th day after the final injection. Observe mouse mortality daily for 10 days after challenge.
9. Calculate the relative percent survival (RPS) to evaluate the protective efficacy according to the mortality recorded daily. The RPS is calculated as $[1 - (\text{mortality of vaccinated group} / \text{mortality of control group})] \times 100$ [10, 11].

4 Notes

1. For the immune protection assay, 6- to 8-week-old female mice can be used.
2. *V. parahaemolyticus* is a Gram-negative halophilic bacterium, so the bacteria should be cultured with high-salt medium.
3. Acrylamide is a potentially toxic and potentially cancer-causing neurotoxin, so gloves and a surgical mask should always be worn when weighing acrylamide powder.
4. Ammonium persulfate solution should be prepared freshly each time.
5. Always wear gloves when handling the NC or PVDF membranes.
6. When transfer large proteins, up to 0.5 % SDS can be added into the transfer buffer.
7. The reagents of DAB and nickel chloride in the kits are suspected carcinogens. Take care to avoid touching these reagents.
8. The water and ACN that are used in in-gel protein digestion and mass spectrometry procedures must be HPLC grade.
9. Reduction buffer should be prepared freshly.
10. Alkylation buffer should also be prepared freshly.
11. A stable emulsion induces a stronger immune response than an unstable one. To check the emulsification endpoint, add one drop of emulsion to cold water and do not disperse.
12. After clot formation, rim the clot with a wooden applicator stick to dislodge the clot from the surface of the tube, but do not break up the clot. If needed, collect the antiserum after centrifugation at $10,000 \times g$ for 30 min at 4 °C.
13. The collection of mouse blood can be facilitated by using a heat lamp to warm the mouse for 30–60 s before cutting the tail.
14. Approximately 0.2–1.0 μg of proteins should be spotted in each pane in the assay.

15. If the antiserum titer is low, the immunization must be boosted more.
16. The 4–20 % gradient gels can be better used for the second dimension of SDS-PAGE. These gels can separate proteins very well.
17. Take care to avoid touching the membranes and gels when preparing the gel-membrane sandwich.
18. Dilute the antibody in TBST in a proper ratio according to the antiserum titer.
19. It is recommended to utilize DAB developing method to display the protein spots in situ.
20. The development time is generally 2–20 min at room temperature. When the stained spots are clearly visible, rinse the membrane as soon as possible in water.
21. Care should be taken to avoid the loss of gel particles, as well as to prevent keratin contamination of protein samples.
22. Tubes can be wrapped entirely by foil.
23. If needed, add more trypsin solution to cover all gel pieces depending on the amount of protein.

Acknowledgements

This work was supported by grants from the NSFC (31200110), the Natural Science Foundation of Zhejiang Province (LY15C010004), the 521 Talent Program of Zhejiang Sci-Tech University to J. Pan.

References

1. Wimley WC (2003) The versatile beta-barrel membrane protein. *Curr Opin Struct Biol* 13:404–411
2. Fairman JW, Noinaj N, Buchanan SK (2011) The structural biology of β -barrel membrane proteins: a summary of recent reports. *Curr Opin Struct Biol* 21:523–531
3. Lin J, Huang S, Zhang Q (2002) Outer membrane proteins: key players for bacterial adaptation in host niches. *Microbes Infect* 4:325–331
4. Mao Z, Yu L, You Z, Wei Y, Liu Y (2007) Cloning, expression and immunogenicity analysis of five outer membrane proteins of *Vibrio parahaemolyticus* zj2003. *Fish Shellfish Immunol* 23:567–575
5. Lun J, Xia C, Yuan C, Zhang Y, Zhong M, Huang T, Hu Z (2014) The outer membrane protein, LamB (maltoporin), is a versatile vaccine candidate among the *Vibrio* species. *Vaccine* 32:809–815
6. Jungblut PR (2001) Proteome analysis of bacterial pathogens. *Microbes Infect* 3:831–840
7. Klade CS (2002) Proteomics approaches towards antigen discovery and vaccine development. *Curr Opin Mol Ther* 4:216–223
8. Jang YH, Subramanian D, Heo MS (2014) Efficacy of formalin-killed *Pseudomonas anguilliseptica* vaccine on immune gene expression and protection in farmed olive flounder, *Paralichthys olivaceus*. *Vaccine* 32:1808–1813
9. Doig P, Trust TJ (1994) Identification of surface-exposed outer membrane antigens of *Helicobacter pylori*. *Infect Immun* 62:4526–4533
10. Li H, Ye MZ, Peng B, Wu HK et al (2010) Immunoproteomic identification of polyvalent vaccine candidates from *Vibrio parahaemolyticus* outer membrane proteins. *J Proteome Res* 9:2573–2583
11. Li C, Ye Z, Wen L, Chen R et al (2014) Identification of a novel vaccine candidate by immunogenic screening of *Vibrio parahaemolyticus* outer membrane proteins. *Vaccine* 32:6115–6121

Construction and Immunogenicity Testing of Whole Recombinant Yeast-Based T-Cell Vaccines

Thomas H. King, Zhimin Guo, Melanie Hermreck, Donald Bellgrau, and Timothy C. Rodell

1 Introduction

Tarmogens are comprised of heat-inactivated, whole recombinant *Saccharomyces cerevisiae* yeast cells expressing disease-related target antigens, most typically intracellularly. These vaccines possess unique cell surface molecular signatures (pathogen-associated molecular patterns) that are key agonists for phagocytic and toll-like receptors expressed by antigen-presenting cells (APCs). Following vaccination with Tarmogen, receptor binding and activation of APCs trigger yeast uptake and cross-presentation of heterologous yeast-expressed antigens with class I and class II MHC molecules, in turn stimulating CD4⁺ and CD8⁺ T-cell responses in vivo [1]. The yeast also induces the Th17 pathway resulting in reduced regulatory T-cell activity [2, 3]. With help from the CD4⁺ T-cell population, the CD8⁺ T cells specifically kill and/or clear virus-infected cells and tumor cells expressing the target antigen.

Tarmogens are being developed clinically for the treatment of chronic human viral infections and a variety of cancers [4]. The broad applicability of the platform is also being widely exploited in basic vaccine research.

Functional evaluation of Tarmogens is accomplished by any of a wide array of in vivo and in vitro assays that can illuminate the activity and mechanism in different host immunological backgrounds. For Tarmogens targeting tumor-associated antigens, many clinically relevant and tractable rodent models exist that require only lower biosafety level (e.g., ABSL1) animal facilities for execution and that inherently evaluate activity in the context of immunological tolerance and suppression [5–7]. Achieving a similar level of immunological relevance for infectious diseases often involves challenge of immunized animals with a target microorganism. As selection of a lead candidate Tarmogen would ideally

include testing of multiple candidates and immunization regimen optimization, such infectious animal models can be prohibitively long and expensive.

These latter obstacles can be ameliorated with a project plan that includes (1) infectious ex vivo assays with T cells and monocyte-derived dendritic cells from a patient's blood [8] and (2) noninfectious in vivo murine experiments emphasizing the cellular mechanisms of activity in the context of Tarmogen immunization. Following on this theme, we describe four methods that in our hands provide high-magnitude antigen-specific T-cell responses in a relatively short time frame with moderate resources.

2 Materials

Supplier details are provided where reagent source or quality is particularly important.

1. *S. cerevisiae* haploid yeast (e.g., genotype *ade2-1; ura3-1; his3-11,15; trp1-1; leu2-3,112; can1-100*; or a closely related strain).
2. Two μm circle-based shuttle vector with yeast and *E. coli* origins of replication, an auxotrophic selectable marker (e.g., URA3 or HIS3), a bacterial antibiotic resistance gene (β -lactamase), and a multiple cloning restriction cluster adjacent to the copper-inducible CUP1 promoter.
3. General DNA cloning reagents (restriction enzymes, T4 DNA ligase, DH5-alpha competent *E. coli*, Luria broth liquid and solid plates each containing 50 $\mu\text{g}/\text{mL}$ of ampicillin, and standard materials for agarose gel electrophoresis).
4. Frozen-EZ yeast transformation kit II (Zymo Research, cat # T2001).
5. Synthetic complete medium agar plates lacking uracil for selection of transformed yeast containing a URA3 selectable marker.
6. Liquid synthetic complete medium lacking uracil ("U2"): 15 g/L glucose, 6.7 g/L yeast nitrogen base containing ammonium sulfate but lacking amino acids, 0.04 g/L adenine, 0.04 g/L histidine, 0.04 g/L tryptophan, and 0.06 g/L leucine. Sterilized by 0.2 μM filtration.
7. Sterile 1 M copper sulfate solution.
8. Calcium- and magnesium-free phosphate-buffered saline (PBS).
9. Sterile disposable Erlenmeyer flasks with vented caps (2 L, 1 L, 250 mL sizes).
10. 2 \times complete yeast cell lysis buffer, per 100 mL: 4 g SDS, 2 mL β -me, 1 mg bromophenol blue, 1 \times protease inhibitor cocktail, and 1 mM EDTA.

11. Acid-washed glass beads, 0.5 mm.
12. User selected materials for SDS-PAGE and Western blot analyses.
13. Hexahistidine-tagged NS3-his standard protein or equivalent purified his-tagged antigen for Western blot standard curves.
14. Mouse monoclonal antibody recognizing a hexahistidine epitope.
15. Horseradish peroxidase-coupled goat anti-mouse antibody.
16. Enhanced chemiluminescence substrate (*see Note 1*).
17. Bio-Rad digital imager with Chemidoc software or equivalent system for light emission quantification.
18. Aim-V base medium.
19. 100× penicillin-streptomycin solution.
20. Human type AB serum (Invitrogen/Life Technologies cat # 34005100).
21. Complete Aim-V medium: Aim-V containing 10 % human type AB serum plus 1× penicillin-streptomycin.
22. A nonenzymatic cell dissociation buffer.
23. Recombinant human GM-CSF.
24. Recombinant human IL-4.
25. Recombinant human IL-2.
26. PE-coupled antihuman interferon gamma (IFN γ) clone 4SB3.
27. APC-Cy7-coupled antihuman CD8, clone SK1.
28. PerCP/Cy5.5-coupled antihuman CD4, clone SK3.
29. Peptides of 98 % purity.
30. Intracellular cytokine staining kit.
31. Human IFN γ ELISpot kit.
32. Murine IFN γ ELISpot kit.
33. Cesium-137 cell irradiator.
34. Multichannel flow cytometer (recommended 6-color or higher capability).
35. ViraPower Lentiviral Expression System (Invitrogen/Life Technologies cat # K4990-00; **Note 2**).
36. Thermal cycler.
37. Animal research facility/vivarium with biological safety cabinet.
38. Controlled temperature CO₂ tissue culture incubator.
39. Microcentrifuge and clinical swinging bucket centrifuges.
40. Heat-inactivated fetal bovine serum.

41. Lipofectamine 2000 (Invitrogen/Life Technologies cat # 11668027).
42. 25 g×5/8 1 mL TB syringe (for subcutaneous (SC) injections).
43. 28 g insulin syringe (for intradermal (ID) injections).
44. Electric razor for shaving murine injection sites (for ID vaccination and tumor implantation).
45. Digital calipers for tumor measurements.
46. Autoclavable stainless steel dissection tools (for lymph node and spleen removal).
47. 6-well flat bottom and 96-well round bottom tissue culture plates.
48. Sterile 70 µm cell strainers.
49. Sterile 50 mL polypropylene Falcon tubes.
50. Anti-CD40 antibody (Bio-X-Cell cat. # BE0016-2).
51. PKH26 labeling kit (Sigma cat # PKH26GL-1Kt).
52. CFSE (carboxyfluorescein succinimidyl ester) labeling kit.
53. Opti-MEM® reduced serum medium.
54. Tissue culture grade DMSO.
55. Gas pressure regulator and veterinary manifold.
56. Isoflurane controlled release unit (*see Note 3*).
57. Mouse cage with Plexiglass cover connected to gas supply hose.
58. Compressed oxygen; 24 ft³-sized tank.
59. Leucosep™ tubes for PBMC preparation from human whole blood (VWR cat # 89048-936).

3 Methods

3.1 Recombinant Yeast Vaccine Construction and Antigen Quantification

Design of heterologous antigen to be expressed in yeast

The heterologous disease antigen should ideally possess the following attributes: (1) high intracellular expression (preferably > 5 % of total yeast cellular protein), (2) the presence of key epitopes and antigenic regions that are relevant to the stage/cycle of the target disease, and (3) high solubility to avoid inducing the unfolded protein response or other deleterious pathways in the yeast [7, 9, 10]. We have generally included a C-terminal epitope tag (e.g., hexahistidine) to facilitate quantification of the antigen in yeast lysates (see below).

3.1.1 Expression Vector and Promoter Sequences

To obtain stable and reliable antigen expression in *S. cerevisiae*, select a shuttle vector plasmid with a 2 µm circle high-copy origin

of DNA replication, a yeast auxotrophic “selectable” marker such as wild-type URA3, a β -lactamase (AmpR) for antibiotic selection, and a standard bacterial origin of replication. There are many choices of promoters that may be used to achieve high antigen expression in yeast, as reviewed in [11]. We have had good success with the copper-inducible CUP1 promoter [8, 9].

3.1.2 Cloning

1. Standard procedures are deployed to insert a PCR-amplified or commercially synthesized DNA insert proximal to the promoter. The insert may be codon optimized for expression in *S. cerevisiae* but this is usually not essential (*see Note 4*).
2. Kozak sequence. Yeast mRNA translation is not as sensitive to the identity of the start codon-proximal nucleotides as are mammalian cells. Nevertheless, effects on translation have been observed and good guides on this topic are published [12].

3.1.3 Tarmogen Construction

This protocol is for use with CUP1 promoter-driven heterologous antigens. For strains with constitutive promoters, perform the same steps but omit the addition of copper sulfate (step 8).

1. Obtain a *Saccharomyces cerevisiae* haploid yeast strain harboring multiple auxotrophic markers for selection and maintenance of plasmid expression vectors (*see Subheading 2*). Revive the cells from a frozen vial by aseptic streaking on CM glucose agar plates followed by incubation at 30 °C for 3 days.
2. Inoculate a 25 mL volume of synthetic complete liquid medium (“CLM”) with a single colony. Shake the culture at 250 rpm at 30 °C until a density of 3×10^7 cells/mL $\pm 0.5 \times 10^7$ cells/mL has been reached (*see Note 5*).
3. Harvest cells and render them competent for DNA uptake using the Frozen-EZ yeast transformation kit II and conduct transfection of the yeast cells with plasmid DNA according to the kit protocol (Zymo Research).
4. Plate 150 μ L of the transfectant mixture on CM glucose minus uracil plates, and return to a 30 °C incubator for 3 days.
5. Re-streak three individual colonies onto a fresh CM glucose minus uracil plates and return to 30 °C incubator for three additional days.
6. Inoculate a small portion of each re-streaked transfectant into 20 mL of liquid CM glucose minus uracil medium and incubate at 30 °C (250 rpm) for 16 h (starter culture).
7. Obtain a cell count of the three starters and use these to inoculate final cultures to 0.3 YU/mL (one YU = 10^7 yeast cells).
8. Incubate the cultures to a density of 3 YU/mL ± 1 YU/mL and then add copper sulfate from a sterile 1 M stock to a final

concentration of 400 μM . Return to shaker and incubate for a further 3 h at 30 °C (250 rpm).

9. Harvest the cells by centrifugation at $2600\times g$ for 7 min at 20 °C. Resuspend the cell pellet by hand vortexing and then add PBS to 500 mL per liter of original culture, invert the container, and harvest again by centrifugation. Decant the supernatant and resuspend the yeast pellet in the residual liquid as above.
10. Heat inactivate the yeast by adding the cell slurry to pre-warmed 56 °C PBS for 1 h (final yeast concentration: 10–50 YU/mL).
11. Wash the cells three times in PBS as in **step 9**. Resuspend the Tarmogen at an estimated 50 YU/mL, sonicate an aliquot for 10 s to disperse any aggregates, and then obtain an exact cell density by hemocytometer count.

3.1.4 Preparation of Yeast Cell Lysate (See Note 6)

1. Pellet 20 YU of Tarmogen by centrifugation at $5900\times g$ in a tabletop microcentrifuge for 4 min. Keep the cell pellet on ice.
2. Prepare 500 μL of 2 \times complete cell lysis buffer per strain to be evaluated (materials).
3. Remove the supernatant (**step 1**) and resuspend the cell pellet in 200 μL of 2 \times complete cell lysis buffer and add the slurry to a 3 mL polystyrene snap-cap tube containing 300 μL of acid-washed glass beads. Vortex by hand at maximum speed for 90 s and then heat at 95 °C for 3 min. Place the tube on ice for 1 min.
4. Using a p200 pipet attached to a tip from which the very end has been cut off, stick the tip into the beads and withdraw all of the liquid and transfer it to a fresh 1.5 mL microcentrifuge tube.
5. Add 200 μL of 2 \times SDS buffer to the beads and vortex for 15 s. Remove the liquid with a fresh cut tip and pool it with the previous aliquot of cell lysate.
6. Spin the lysate at $9300\times g$ for 4 min to pellet debris, transfer the supernatant to aliquots, and freeze at $-80\text{ }^{\circ}\text{C}$ (*see Note 7*).

3.1.5 Measurement of Heterologous Antigen Content

1. Conduct measurement of total protein in the lysate using a nitrocellulose-binding/TCA protein precipitation method as described previously [13] (*see Note 8*).
2. Expression of the heterologous antigen is measured by standard Western blot. Estimation of antigen content is typically determined by interpolation of heterologous antigen against a standard curve comprised of known quantities of his-tagged HCV NS3 protein. Lanes with the following amounts of antigen generally produce a linear response: 200, 100, 50, and 25 ng (*see Note 9*).

3.2 Immunogenicity Assays

A wide array of *in vivo* and *ex vivo* assays were developed by our laboratory. The four assays described here are examples that provide high-amplitude antigen-specific Th1 T-cell responses. The use of human dendritic cell/peripheral blood mononuclear cell (PBMC) assays enables the study of cellular immune responses in the context of varied exposure to pathogens or in a variety of tumor patient backgrounds. The murine assays are relevant because T-cell responses are mounted *in vivo* by Tarmogen immunization. The *in vivo* cytotoxic T-lymphocyte (CTL) assay is an especially attractive test in cases where a dominant target epitope is known, and it attests to the primary mechanism by which Tarmogens function.

3.2.1 *Ex Vivo Stimulation of PBMCs with Tarmogen-Pulsed, Autologous Dendritic Cells (DCs; ELISpot Readout)*

In this assay, human donor PBMCs are cultured with Tarmogen-treated autologous DCs. Two or three 1-week periods (rounds) of stimulation trigger activation and expansion of disease antigen-specific T cells, resulting in a polyclonal population of lymphocytes whose specificity and activity can be evaluated with ELISpot, intracellular cytokine staining, pentamer staining, or CTL-mediated killing assays [8, 14].

1. Prepare PBMCs from fresh whole blood of donors using Leucosep tubes.
2. Incubate ten million viable PBMCs in a single well of a 6-well plate for 2 h in 5 mL of complete AIM-V medium (cAIM-V).
3. Discard the nonadherent cells and gently rinse once with cAIM-V to remove loosely adherent cells.
4. Add five mL of cAIM-V containing 100 ng/mL recombinant human GM-CSF plus 20 ng/mL recombinant human IL-4 to the adherent cells and incubate for 5 days at 37 °C.
5. Estimate the number of DCs by trypan blue dye exclusion of a (destructive) sister well and then add Tarmogen at a ratio of 1 yeast cell to 1 DC. Return the plate to the incubator for an additional 40 h (*see Note 10*).
6. Rinse the adherent yeast-fed cells twice with calcium- and magnesium-free PBS and then incubate for 15 min with 2–3 mL nonenzymatic cell dissociation buffer at 37 °C. Gently and repeatedly pipet the Tarmogen-pulsed DCs (TPDCs) to detach them from the plastic, irradiate the cells (30 Gy), and store on ice.
7. Thaw 10–20 million frozen autologous PBMCs, wash them in pre-warmed cAIM-V, count, and combine the PBMCs with irradiated yeast-pulsed DCs at a ratio of 1:10 (DC:PBMC) in a T-75 tissue culture flask (*see Note 11*).
8. Incubate the DC/PBMC co-culture for 3 days at 37 °C and then add recombinant human IL-2 at a final concentration of 20 U/mL for 4 additional days. This process comprises one round of stimulation (1 week).

9. Transfer the suspension cells from the round 1 stimulation to a new flask and conduct a round 2 stimulation with freshly prepared TPDCs produced from frozen/banked autologous PBMCs.
10. Repeat the process of DC co-culture once more (**steps 7–9**), using the suspension cells from round 2. This is the third round stimulation.
11. On day 6 of the third round, thaw a vial of fresh autologous PBMCs, wash them in cAIM-V, and incubate with 3 µg/mL of purified recombinant target antigen for 24 h to allow antigen uptake and presentation by APCs.
12. Wash the pulsed APCs (**step 11**) 1× in cAIM-V, count, and add them to the third round DC-stimulated effector population at a T cell/APC ratio of 10:1 for 36 h directly in an IFNγ ELISpot plate (200,000 cells/well). Develop the ELISpot plate per manufacturer's protocols. ELISpot counting can be conducted by Cellular Technology, Ltd.

3.2.2 Ex Vivo Stimulation of PBMCs with Tarmogen-Pulsed, Autologous DCs (Intracellular Cytokine Staining Readout)

As an alternative or in addition to the ELISpot assay of **step 12**, an intracellular cytokine staining assay can be conducted that is useful for establishing the T-cell subsets that have been activated as well as their epitope sequence specificity (*see Note 12*). In the present example, protocols are listed for determining the frequency of CD4⁺ or CD8⁺ IFNγ⁺ T cells. For antibody concentrations used for staining steps, follow manufacturer's recommendations.

1. Generate effectors by stimulation with TPDCs as in **steps 1–11**, Subheading **3.2.1**.
2. Collect an aliquot of cells following complete three-round stimulation, by centrifugation at 300 × *g* for 6 min.
3. Treat the cells with 1× GolgiStop from the BD Cytofix-Cytoperm kit in the presence of disease antigen-specific peptides for 5 h at 37 °C. Stain the cells with antihuman CD8/APC-Cy7 antibody and antihuman CD4/PerCP-Cy5.5 antibody and then wash the cells 3 times with cold PBS + 1 % BSA.
4. Fix the stained cells with 4 % paraformaldehyde for 10 min at 25 °C, permeabilize with the Cytofix-Cytoperm kit, and stain the cells with a PE-coupled antihuman IFNγ antibody. Analyze the cells by flow cytometry to determine the percentages of each T-cell subset that produced IFNγ in response to peptide stimulation.

3.2.3 Tumor Challenge in Tarmogen-Vaccinated Mice

Tumor challenge assays are a time-proven gold standard measure of immunogenicity, and yet establishing the optimal conditions for use with Tarmogens involves knowledge of tumor target construction, careful selection of immunization dose/regimen, tumor challenge dose and timing, and, in the case of adoptive transfer studies,

procedural details to maximize the expansion of transferred T cells prior to challenge. Following these protocols will accelerate the completion of conclusive tumor challenge studies with Tarmogens.

3.2.4 Target Construction

It is recommended to use a system for antigen expression that results in stable chromosomal integration of the target gene such that cells can ultimately be propagated in the absence of drug selection *in vivo* (*see Note 13*).

1. EL4 thymoma cells (ATCC) are grown in cRPMI-10 to mid-exponential phase and then transduced by lentivirus expressing the target gene (*see Note 14*). Cloning, transduction, and drug selection procedures recommended by Invitrogen (Life Technologies) work well for most genes.

3.2.5 Adoptive Transfer-Based Tumor Protection

1. Immunize C57BL/6 mice subcutaneously once per week for 3 weeks (this regimen has not been fully optimized). Immunize with 2.5 YU of Tarmogen in the outer flank and 2.5 YU in the scruff of the neck. Rotate sides of flank injection each week to minimize irritation.
2. One week after the third immunization, harvest splenocytes by gentle dispersal over a 70 μm cell strainer and conduct one wash with cRPMI-10. Do not perform ammonium chloride-potassium lysis of red blood cells.
3. Adjust the preparation to 2×10^7 viable cells/mL and inject 1 mL into the intraperitoneal cavity of 5–7 week old scid mice.
4. Twenty four hours later (to allow for *in vivo* T-cell expansion), challenge the scid mice subcutaneously in the (shaved) ribcage with 30,000 EL4 tumor cells expressing a relevant (*i.e.*, target) or irrelevant control antigen (*see Note 15*).
5. Monitor tumor growth daily starting 48 h after challenge. Tumors will likely become visible in control (PBS or irrelevant yeast) groups ~day 6 or 7 post-challenge (*see Note 16*).
6. When tumors are large enough to be measured by digital caliper, collect tumor diameter measurements daily, in two perpendicular dimensions for each mouse. Plot average tumor diameter or tumor volume as a function of time to estimate growth rate.

3.2.6 Interferon Gamma ELISpot in Tarmogen- Immunized Mice

Ex vivo T-cell activation assays are valuable protocols for assessing the antigen specificity of therapeutic vaccines. For Tarmogens, we have found that several differences from traditional methods result in enhanced antigen-specific responses. Heterologous antigen expression level, immunization regimen/dose, period of rest prior to dissection, and the type and purity of antigen are all factors that can affect assay quality.

1. Immunize mice with 5 YU of Tarmogen by the intradermal or subcutaneous routes (2.5 YU each outer flank) at days 0 and 7. To achieve representative results, it is recommended to immunize at least seven mice per treatment group (*see Note 17*).
2. Nine to 21 days post-immunization, remove the draining inguinal lymph nodes from the 7 mice/group, pool the organs for each group, and immediately disperse the cells into cold cRPMI-10 over a 70 μM cell strainer using the flat end of a 3 mL syringe plunger.
3. Wash the cells once in 50 mL cRPMI-10, resuspend in 3 mL medium, and obtain viable cell counts by hemocytometer counts of trypan blue-stained cells.
4. Adjust the preparation to 2.5 million viable cells per mL and aliquot 100 μL per well into 96-well round bottom tissue culture plates.
5. Add 100 μL of target or irrelevant antigen in cRPMI-10 to each well, mix by gentle pipetting, and place the covered plate in a humidified 37 °C/5 % CO₂ tissue culture incubator for 4 days (*see Note 18*).
6. Pipet the cells up and down 3 times with a multichannel pipet and transfer 150 μL of the mixture to a pre-blocked 96-well IFN γ ELISpot plate. Return the plate to the CO₂ incubator for 24 h.
7. Wash the cells off of the ELISpot plate and develop the assay exactly per R&D systems kit directions. Dry plates at 37 °C for 30–60 min prior to spot counting.

3.2.7 *In Vivo* CTL

The ability of Tarmogens to trigger cytotoxic T-cell-mediated killing is central to the mechanism of action, and here we present a rapid (8-day), simple, and highly relevant *in vivo* assay to assess this function. A key requirement is that a class I MHC-restricted dominant epitope is known. The assay can be run in most any strain of mouse including HLA transgenic mice to allow the possibility of testing for CTL against epitopes of known importance in human disease.

The key steps are (1) immunization of mice (day 0), (2) injection of immunized and naive mice with dye-labeled and peptide-pulsed and unpulsed splenocytes (day 7), and (3) removal of spleens followed by analysis of percent killing of the dye-labeled population by flow cytometry.

Immunization of Mice with Tarmogen

1. Immunize mice retro-orbitally or by tail vein injection with 2 YU of Tarmogen mixed with 25 μg of $\alpha\text{-CD40}$ antibody (*see Note 19*).

Target Preparation

Except for step 6, all centrifugation steps are performed at 400×g for 10 min.

1. On day 7 post-immunization, harvest spleens from naive syngeneic mice and prepare them as targets for killing as follows. The following is written for a single spleen which contains sufficient cells to inject four recipient mice. A total of 4×10^6 cells/recipient are required (2×10^6 peptide-pulsed and 2×10^6 unpulsed cells).
2. Macerate spleen in PBS + 1 % BSA (wash medium; W1) and filter cells into a 50 ml Falcon tube using a 70 μ M mesh filter and centrifuge. Discard supernatant and continue with **step 3**. Perform all subsequent steps at room temperature.
3. Lyse red blood cells for 5 min by resuspending pellet in 2 mL ACK (ammonium chloride-potassium) lysing solution per spleen.
4. Add 15 mL complete RPMI-10 % FBS (cRPMI-10) to stop the reaction. Centrifuge, resuspend the cells in 10 mL W1, and obtain a viable cell count.
5. Reserve 4×10^6 unstained cells as a control (2×10^6 to be used as no staining control and 2×10^6 for CFSE (carboxyfluorescein succinimidyl ester)-only stained control).
6. Centrifuge the cells from **step 5** at 400×g for 5min into a loose pellet.
7. Carefully aspirate the supernatant leaving no more than 25 μ L of supernatant on the pellet.
8. Based on the estimated number of cells from the count in **step 5**, resuspend the cells at 2×10^7 /ml in Diluent C from the PKH26 staining kit (this is a 2× cell suspension). Ensure the cell suspension is uniform but do not vortex.
9. Immediately prior to staining, prepare 8×10^{-6} M PKH26 dye (2× mix) in a polypropylene tube using Diluent C. If an intermediate dilution of dye is necessary (unlikely), do so in 100 % ethanol. Hold this preparation at 25 °C.
10. Add 8 μ L of 1×10^{-3} M PKH dye stock per 1 ml Diluent C. Rapidly add the 2× cells to the 2× dye and immediately mix the sample by pipetting. Rapid and homogenous mixing is critical for uniform labeling because staining is nearly instantaneous.
11. Incubate the cells at 25 °C for 3 min. Periodically, invert the tube gently to ensure mixing during this staining period at 25 °C.
12. Stop the staining reaction by adding an equal volume of 100 % fetal bovine serum (2 mL cell/dye mix + 2 mL serum). Incubate for 1 min at 25 °C.
13. Dilute the serum-stopped sample with an equal volume of cRPMI-10.

14. Centrifuge the cells at $400 \times g$ for 10 min at room temperature to remove cells from staining solution (*see Note 20*).
15. Remove the supernatant and wash cells with 15 ml cRPMI-10 (a minimum of three washes is recommended). Perform the last wash using 15 mL PBS. Count an aliquot of the cells while in the last centrifugation step and resuspend the cells to $4\text{--}5 \times 10^7$ cells/mL in PBS. Retain 5–10 μL of the PKH26 stained preparation as a single-stained control.
16. Divide the PKH26-stained cells equally into two polypropylene tubes. One sample will be stained with 1 μM CFSE (CFSE high) and the second sample with 0.1 μM CFSE (CFSE low).
17. Prepare a 2 \times CFSE pre-mixture (2 μM and 0.2 μM , respectively) in PBS and add an equal volume to the PKH26-labeled cells (1 mL cells + 1 mL 2 \times CFSE). Stain at room temperature for 10 min.
Also in parallel, treat 2×10^6 unstained splenocytes from above with 1 μM CFSE in a volume of 2 mL for 10 min (1 mL cells + 1 mL 1 μM CFSE).
18. Stop the CFSE labeling by adding equal volume of 100 % FBS for 1 min and then add one volume of cRPMI-10 and centrifuge as above.
19. Wash the cells once more with cRPMI-10 and once with W1. Resuspend the cells stained with 1 μM CFSE (CFSE-high cells) in serum-free medium (SFM) for peptide pulsing. Use 1 mL SFM for cells from up to five donor spleens and increase volume accordingly dependent on number of spleens used. Resuspend the cells stained with 0.1 μM CFSE (CFSE-low cells) in 5 mL PBS and hold at 4 °C until further use.
20. Pulse the CFSE high population with 100 μM peptide (*see Note 21*) in polypropylene tubes at 37 °C 5 % CO_2 for 60 min.
21. Dilute the peptide-pulsed splenocytes to 20 mL with SFM and centrifuge for 10 min. Aspirate the supernatant carefully to remove as much medium as possible without losing cells.
22. Wash the CFSE-high cells with 20 mL PBS, centrifuge, and resuspend the pellet in 5 mL PBS.
23. Count both CFSE-high and CFSE-low preparations and mix 2×10^6 pulsed (CFSE-high) cells with 2×10^6 unpulsed (CFSE-low) cells in 100 μL total volume per mouse to be injected. Inject the suspension retro-orbitally into naïve and into Tarmogen-immunized mice using a U-100 insulin syringe, 28G1/2 (0.36 mm \times 13 mm).

Harvest and Processing
of Spleens for Flow
Cytometry

1. 20-h post-challenge, remove spleens and process organs as described in **steps 2–4**.
2. Transfer $10\text{--}15 \times 10^6$ cells to a 15 ml Falcon tube and adjust the cell concentration to $5 \times 10^6/\text{ml}$ using W1.

Flow Cytometric Analysis

1. Transfer 2 ml of each sample prepared in **step 2** above to a 5 mL polystyrene tube. Filter over a 70 μ M mesh cell strainer if cell clumps are visible. Resuspend the cells used as single stain controls from **steps 5, 15, and 17** in 1 mL W1 and also transfer to a 5 mL polystyrene tube. Keep samples on ice.
2. On the flow cytometer, create the experiment layout for analysis. Include a dot plot for forward (x -axis) and side scatter (y -axis), as well as a dot plot displaying PKH26 (x -axis) against side scatter (y -axis). Add a histogram plot for displaying CFSE (x -axis) against counts (y -axis).
3. Use the unstained control to adjust forward and side scatter as well as photomultipliers for the detectors used (*see Note 22*).
4. Compensate the spillover between CFSE and PKH26 using the single stain controls (*see Note 23*).
5. Run the sample corresponding to the “naïve” mouse (*see step 23*) to set and adjust the gates to display the different populations. Begin with adding a lymphocyte gate to the forward-side scatter plot (gate 1). In the “PKH26 vs. side-scatter” plot, display events from gate 1 and set a 2nd gate around the PKH26-positive population (*see Note 24*). In the CFSE histogram plot, display the PKH26-positive cells (gate 2). The CFSE-labeled cells should be visible as two separate peaks, CFSE-high and CFSE-low cells, respectively. Set “region” gates for each peak to determine the frequency of CFSE-high cells versus CFSE-low cells (*see Note 25*).
6. After gates have been set, record the sample and continue to acquire the rest of the samples in the experiment. In order to obtain a satisfying analysis, it might be required to record up to 5×10^6 events in gate 1, as PKH26-/CFSE-labeled cells can be limited.
7. The efficacy of cytotoxic T-cell lysis (target-cell killing) of peptide-pulsed (CFSE-high) cells is measured in percent and calculated by the following formula:

$$\% \text{ killing} = \left(1 - \frac{\text{immunized CFSE hi} / \text{CFSE low}}{\text{Naïve CFSE hi} / \text{CFSE low}} \right) \times 100$$

4 Notes

1. Optimal sensitivity is obtained with a digital imager such as Bio-Rad’s digital imaging system interfaced to ChemiDoc software.
2. The polyubiquitin C or cytomegalovirus promoters are good choices for constitutive mid- to high-level expression; these may be selected upon purchase of the lentiviral kit.

3. Isoflurane anesthesia is used for the intradermal and retro-orbital injection procedures described in the Methods section.
4. The benefit of codon optimization for expression in yeast is controversial, and in our hands, many DNA sequences encoding viral pathogens or tumor-associated antigens express highly without optimization.
5. Before counting yeast cell by hemocytometer, the culture should be sonicated on low power for 10 s to ensure dispersal of cell aggregates.
6. The combination of mechanical shearing, high SDS (4 %), and heat (95 °C) is optimal to obtain high efficiency of lysis from heat-killed yeast.
7. Yeast total protein lysates are optimally stored at -80 °C in aliquots.
8. The use of the amido-schwartz TCA precipitation method is important for lysates produced by this method, as it is insensitive to high SDS concentrations. Unlike certain other popular methods, it is also inclusive of membrane proteins and therefore produces a more accurate estimate of total cellular protein than other commercial methods.
9. Despite that the ECL product has a stabilizer, data should be collected immediately upon exposure to substrate as antigen content results can vary by as much as 100 % when longer ECL substrate incubation is conducted (e.g., 30 min) prior to digital image collection.
10. The yeast/DC ratio should be titrated to achieve optimal separation of the Tarmogen-emergent T-cell effect to the background signal arising from negative control empty vector yeast cells.
11. On the same day as the autologous PBMCs are thawed for co-culture with yeast-pulsed DCs, a fresh lot of DCs must be initiated as in **step 2**.
12. As an example of evaluating other markers, antibodies that can detect degranulation may be added concomitant with CD8 marker staining to determine if the cells are cytolytic [15].
13. Plasmid-based nonviral transfection methods can be used to establish antigen expression but the frequency of stable integration is low and thus antigen expression will usually be lost in the absence of drug selection in vitro and in vivo. We have isolated “breakthrough” tumors (those that continued to grow rapidly even in vaccinated mice) and found that the vast majority of cells in these tumors were devoid of heterologous antigen expression
14. The operator may also choose to fuse the target gene to a ubiquitin sequence that accelerates proteasomal degradation and

enhances antigen presentation with class I MHC. However, if using this proteasomal targeting approach, detection of antigen expression by Western blot can be difficult and requires the use of proteasome inhibitors prior to lysate preparation [16].

15. We have found that 30,000–90,000 target cells provided optimal results in many studies, with tumors forming in 90 % of mice treated with empty vector control yeast. However, it is recommended to titrate the dose for each tumor line that expresses a unique antigen, as some heterologous proteins affect tumor growth rate. It is also noted that the well-known EL4-based tumor line E.G7-Ova grows notably more slowly than EL4 cells expressing, e.g., viral antigens. This can affect the interpretation of results when the protective effect of one Tarmogen vaccine is assessed against two different tumor targets lines. Always determine the growth rate of different EL4 lines before comparing them side by side in vaccine studies.
16. The greatest separation of tumor growth rate between Tarmogen vs. control yeast-treated mice is often observed in the first few days after tumors have appeared.
17. Higher numbers of Langerhans cells are found in the dermal layer than subcutaneously and these cells cross-prime CD8⁺ T cells with particularly high efficiency [17]. Thus, and especially if seeking to characterize CD8 T-cell responses, it is logical to immunize intradermally. C57BL/6 mice are recommended for these studies due to the Th1 bias of this strain. Nevertheless, CTL can be induced by Tarmogens in other common laboratory strains such as BALB/c and even in transgenic mice expressing high levels of self-antigens [5, 9].
18. For each antigen stimulation, at least six replicate wells should be processed because the efficiency of T-cell activation and expansion can vary greatly from well to well.
19. This amount of yeast and α CD40 Ab has been optimized; higher levels of α CD40 may result in sporadic death of mice.
20. Do not reduce the time of these spins to 5 min, or considerable cell loss might occur.
21. We recommend that peptides be of high purity (98 %) for best results and to ensure reproducibility, as crude peptide preparations can vary dramatically in quality from lot to lot.
22. PKH26 can be detected in the PE channel, whereas CFSE emits in the FITC channel.
23. Both PKH26 and CFSE have excitation and emission spectra that are different from PE and FITC, respectively, and therefore need to be compensated separately, using PKH26- and CFSE-labeled cells.

24. PKH26 is used as a vital dye and only living cells will be labeled. The abundance of those cells within a whole spleen can be very limited. Thus, depending on your flow cytometer, either display at least 5000 events in the “PKH26 against side-scatter” dot plot or record approximately 1×10^6 cells in order to be able to confidently identify the PKH26-positive population.
25. In the naïve mouse, the ratio of CFSE-high cells to CFSE-low cells should be approximately 1:1, as killing of the peptide-pulsed (CFSE-high) population does not occur in those animals. Ratios might be skewed toward the CFSE-high or CFSE-low population if cell counts were inaccurate and/or if the pulsed and unpulsed cells were not mixed in a 1:1 ratio in **step 23**. Nevertheless, the formula used to calculate the percentage of target-cell killing in the immunized animal will account for such variability.

Acknowledgements

We thank Kirk Christoffersen and Dr. Angela Sebor for critical review of the manuscript.

References

1. Stubbs A, Martin KS, Coeshott C et al (2001) Whole recombinant yeast vaccine activates dendritic cells and elicits protective cell-mediated immunity. *Nat Med* 7:625–629
2. Cereda V, Vergati M, Huen N-Y et al (2011) Maturation of human dendritic cells with *Saccharomyces cerevisiae* (yeast) reduces the number and function of regulatory T cells and enhances the ratio of antigen-specific effectors to regulatory T cells. *Vaccine* 29:4992–4999
3. Cheng S-C, van de Veerdonk FL, Lenardon M et al (2011) The dectin-1/inflammasome pathway is responsible for the induction of protective T-helper 17 responses that discriminate between yeasts and hyphae of *Candida albicans*. *J Leukoc Biol* 90:357–366
4. Gaggar A, Coeshott C, Apelian D et al (2014) Safety, tolerability and immunogenicity of GS-4774, a hepatitis B virus-specific therapeutic vaccine, in healthy subjects: a randomized study. *Vaccine* 32:4925–4931
5. Wansley EK, Chakraborty M, Hance KW et al (2008) Vaccination with a recombinant *Saccharomyces cerevisiae* expressing a tumor antigen breaks immune tolerance and elicits therapeutic antitumor responses. *Clin Cancer Res* 14:4316–4325
6. Ardiani A, Farsaci B, Rogers CJ et al (2013) Combination therapy with a second-generation androgen receptor antagonist and a metastasis vaccine improves survival in a spontaneous prostate cancer model. *Clin Cancer Res* 19:6205–6218
7. Ardiani A, Gameiro SR, Palena C et al (2014) Vaccine-mediated immunotherapy directed against a transcription factor driving the metastatic process. *Cancer Res* 74:1945–1957
8. King TH, Kemmler CB, Guo Z et al (2014) A whole recombinant yeast-based therapeutic vaccine elicits HBV X, S and Core specific T cells in mice and activates human T cells recognizing epitopes linked to viral clearance. *PLoS One* 9(7):e101904
9. Haller A, Lauer GM, King TH et al (2007) Whole recombinant yeast-based immunotherapy induces potent T cell responses targeting HCV NS3 and Core proteins. *Vaccine* 25:1452–1463
10. Wu H, Ng BSH, Thibault G (2014) Endoplasmic reticulum stress response in yeast and humans. *Biosci Rep* 34:321–330
11. Shen MWY, Fang F, Sandmeyer S et al (2012) Development and characterization of a vector set with regulated promoters for systematic metabolic engineering in *Saccharomyces cerevisiae*. *Yeast* 29:495–503
12. Nakagawa S, Niimura Y, Gojobori T et al (2008) Diversity of preferred nucleotide

- sequences around the translation initiation codon in eukaryote genomes. *Nucleic Acids Res* 36:861–871
13. Schaffner W, Weissmann C (1973) A rapid, sensitive, and specific method for the determination of protein in dilute solution. *Anal Biochem* 56:502–514
 14. Hamilton DH, Litzinger MT, Jales A et al (2013) Immunological targeting of tumor cells undergoing an epithelial-mesenchymal transition via a recombinant brachyury-yeast vaccine. *Oncotarget* 4:1777–1790
 15. Betts MR, Brenchley JM, Price DA et al (2003) Sensitive and viable identification of antigen-specific CD8⁺ T cells by a flow cytometric assay for degranulation. *J Immunol Methods* 281:65–78
 16. Andersson HA, Barry MA (2004) Maximizing antigen targeting to the proteasome for gene-based vaccines. *Mol Ther* 10:432–446
 17. Liard C, Munier S, Joulin-Giet A et al (2011) Intradermal immunization triggers epidermal Langerhans cell mobilization required for CD8⁺ T-cell immune responses. *J Invest Dermatol* 132:615–625

Chapter 36

Oral Rabies Vaccine Design for Expression in Plants

Ankit Singh, Gauri Saxena, and Praveen C. Verma

1 Introduction

Vaccination involves the stimulation of the immune system to prepare it for the event of an invasion from a particular pathogen for which the immune system has been primed [1]. This will further produce pathogen-specific T and B cells for rapid proliferation and differentiation when natural pathogens will be encountered by immune system. Construction of vaccine in several cases has been hampered because of varying strains of the pathogen, antigen drift, antigenic shift, and other unrevealed mechanisms that make it hard to determine a suitable peptide sequence for the immune system priming. Although attenuated whole pathogens were frequently used for priming the immune system, but that has resulted in acquiring the same disease by few people after vaccination.

Recombinant subunit vaccines are desirable as an alternative with potentially fewer side effects than delivering the whole organism. Recombinant subunit vaccine does not contain whole infectious agent and thus is safer to administer and prepare uniform doses [2]. Now with advancement in molecular biology techniques, it has become feasible to identify the candidate peptides or proteins that are associated with a particular disease development and can be potentially utilized to function as an effective subunit vaccine. Any part of the causal agent including proteins, long-chain carbohydrates, DNA, etc., can be used as a subunit vaccine to prevent and slow down the spread of disease.

Though most of the known methods of vaccination have been effective against several diseases, nevertheless only oral vaccines can ease the discomfort associated with the mode of introduction of vaccines. Oral vaccines have been observed to stimulate production of mucosal antibodies more effectively than the injected ones. The body's mucosal immune system works as a first line of defense

against many diseases. The bronchial system and gut are the two main sites for mucosal lymphoid tissues. An oral vaccine is much safer from the degradation by intestinal acidic pH and is able to produce IgA secretory antibody by stimulating mucosal immune system. However, most of the synthesized secretory antibodies are secreted through tears, saliva, and milk to protect the invasion of the pathogenic organism through these routes, but substantial amount of other antibodies are also present in the blood to tackle the invaded pathogens [3, 4]. Oral vaccination can be a good alternative where multiple booster and priming regimens are required.

Rabies is acute progressive encephalitis which causes annually 60,000 human deaths worldwide [5]. It is caused by a promiscuous neurotropic virus *Lyssavirus* genus of the family Rhabdoviridae. Rabies disease can spread through both wild and domestic animals. The first vaccine against rabies developed by Louis Pasteur contained subcutaneous inoculation of spinal cord suspension from rabid rabbits [6]. Since then, the development of rabies vaccines has been improved considerably [7, 8]. The rabies virus genome encodes five major proteins of which the G-protein of rabies virus has been identified as the major viral antigen that induces protective immunity [9]. Plants are emerging as a promising alternative source for producing safe and cost-effective therapeutic proteins in recent years [10, 11]. Recombinant proteins expressed in plants have shown sufficient promise to warrant human clinical trials [12]. A stable expression of rabies glycoprotein in tomato plants has already been reported [13], while complete protection has been shown when mice were injected with rabies G-proteins expressed and purified from tobacco plants [14].

There are various lectins or lectin-like proteins which have the binding ability for glycolipids or glycoproteins [15]. Many of protein lectins have already been characterized and are used as mucosal adjuvant which stimulates strong humoral as well as cell-mediated immunity. However, we utilize both N- and C-terminal fusion of lectins to rabies glycoprotein for oral administration to avoid near homogeneity purification and to enhance immunogenic property of rabies antigen. Fusion proteins were evaluated further to determine the efficacy of vaccine antigen.

1.1 N-Terminal Fusion with Rabies Glycoprotein

Cholera toxin B subunit (CTB) is one of the most characterized mucosal adjuvant which provides N-terminal fusion capability with target antigens. CTB binds to the GM1 receptor and can serve as a mucosal adjuvant [16]. GM1 receptors are present on most of the cells in the body including leukocytes and epithelial cells. Antigen binding to GM1 could readily increase the uptake across the mucosa and lead to an enhanced presentation of the conjugated molecule to the immune system [17, 18]. Immunogenicity of cholera toxin B subunit (CTB) as N-terminal fusion partner with the rabies glycoprotein has been successfully demonstrated [19].

To enhance the expression, seed-specific promoter with CTB-RGP was also expressed in groundnut, which is an important step for edible version of fusion vaccine [20].

Ricin toxin B subunit (RTB) was also used as the mucosal adjuvant and carrier to enhance immune responses for rotavirus infection [21]. RTB can be utilized as C-terminal fusion carrier for the delivery of the virus antigen to the mucosal immune system and may act as a potential immune modulator to enhance the mucosal immune response of antigens [22].

1.2 C-Terminal Fusion with Rabies Glycoprotein

Ricin toxin (RT) is composed of a galactose-binding B chain (32 kDa) with cytotoxic A chain (30.5 kDa). Ricin toxicity is based on A subunit which inhibits protein synthesis by ribosome inactivation. It acts as a glycosidase that catalyzes the removal of a single adenine residue from a highly conserved loop of the 28S ribosomal RNA (A 4324 in rat 28S RNA) [23]. Interaction between the ricin B chain and terminal galactosidase located on the enterocyte membrane facilitates ricin holotoxin uptake by endocytosis into intracellular vesicles [24]. Ricin B subunit has an advantage that they do not require assembly into multimeric structures prior to receptor binding as required in CTB or LTB [25]. RTB has a wider receptor-binding specificity for membrane receptors than CTB or LTB [17, 25, 26]. RTB binds to receptors which are found on epidermal cell membranes in the range of 1×10^7 to 3×10^7 molecules per cell [25]. Both CTB and LTB bind to GM1 receptors at lower frequencies, about 7.5×10^4 molecules/mucosal epidermal cell [17]. In contrast to CTB and LTB, the monomeric subunit of RTB does not exert fusion protein size constraints and has better ability to deliver larger antigen molecules to gut epithelial cells than CTB or LTB. RTB has been cloned and expressed in various organisms, e.g., *Escherichia coli*, *Saccharomyces cerevisiae*, *Xenopus laevis* oocytes, and *Nicotiana tabacum* [27–30]. C-terminal fusion of RTB with green fluorescent protein (GFP) has been synthesized in transformed tobacco and found to generate a humoral immune response showing the presence of a Th2 response in intranasal immunized mice [22]. The membrane-targeting ability of RTB subunit of plant heterodimeric AB toxin from *R. communis* may serve as a carrier for subunit vaccines. Ricin toxin B subunit (RTB) was employed by us to explore its fusion ability as a C-terminal fusion. It was further utilized as mucosal carrier that possesses the ability to bind with the receptors even in a single monomer condition [31].

This chapter essentially garners the procedure and efforts involved in making N- and C-terminal mucosal adjuvant fusion with rabies glycoprotein and transformation of this fusion construct in plant systems for further expression and subsequent evaluation of their immunogenic property, thereby providing relevant information for developing oral vaccine against rabies.

2 Materials

2.1 *In Silico Analysis of Fusion Proteins*

Software and bioinformatics tools which were used during in silico analysis of fusion proteins are given below:

1. Alignment of amino acid sequences performed through ClustalW program (<http://www.ebi.ac.uk/Tools/msa/clustalw2>).
2. Swiss-Model of the ExPASy server (<http://swissmodel.expasy.org>).
3. MULTICOM protein tertiary structure prediction server (http://www.molbiol-tools.ca/protein_tertiarystructure.html) (*see Note 1*).
4. RAMPAGE: Ramachandran Plot Assessment tool (<http://mordred.bioc.cam.ac.uk/~rapper/rampage.php>).
5. PyMOL software (<http://www.pymol.org>).
6. Hopp-Woods hydrophilicity plot (http://www.scied.com/dl_cmb9d.htm).
7. ProtParam analysis (<http://web.expasy.org/protparam>).

2.2 *Synthesis of Chimeric Fusion Gene*

1. Softwares like Gene designer 2.0 (DNA 2.0), Jcat (Technical University of Braunschweig), Codon Optimization tool (IDT) online free servers and OptimumGene™ Codon Optimization (Gene Script) and Gene optimizer (Life Technologies) like paid software can be used for designing and optimization of gene sequences (*see Note 2*).
2. The Expedite Nucleic Acid Synthesis System and ABI-PRISM 377 DNA sequencer were used for primer synthesis and sequencing.
3. LS55 Luminescence Spectrometer was procured from Perkin Elmer/PE Biosystems Inc, USA.
4. The PCR machine (DNA Engine Tetrad 2 Peltier Thermal Cycler) was procured from Bio-Rad.
5. For gel documentation and imaging, Fluor-S MultiImager system was procured from Bio-Rad, USA.
6. The chemicals for oligonucleotide synthesis were purchased from Pharmacia Biotech, Uppsala, Sweden, and Sigma-Aldrich, St. Louis, Missouri, USA. Thermostable polymerase, namely, Deep Vent DNA polymerase, and restriction enzymes were procured from New England Biolabs.
7. Milli-Q grade water (Millipore) was used in all molecular biology experiments.

2.3 Cloning into Plant Expression Vector

1. Plant expression vectors pBII01 (Clontech) and pCAMBIA1300 (Cambia Labs) were used for cloning of different component of expression cassettes.
2. Binary vector pBII01 [32] was used for the construction of *ctb-rgp* fusion gene expression cassette. It was cloned downstream of duplicated enhancer CaMV35S promoter [33].
3. The assembled *rgp-rtxB* fusion gene and CaMV35S double enhancer promoter were amplified and triple ligated with digested *Tnos* fragment from pBII21 for subsequent subcloning into pCAMBIA1300 at *Pst*I to *Sac*I, *Hind*III to *Pst*I, and *Sac*I to *Eco*RI restriction sites, respectively (see Notes 3 and 4).
4. The insert and vector DNA were purified by Qiagen gel extraction kit or by LMP gel electrophoresis using β -agarase enzyme (New England Biolabs) digestion as per the manufacturer's instructions (see Note 3).

2.4 Generation of Transgenic Lines

1. In vitro grown *Nicotiana tabacum* cv. Petit Havana (maintained in the laboratory) on Hoagland media (HiMedia) and *Agrobacterium tumefaciens* strain LBA4404 (DCS, Germany) containing helper plasmid pAL4404 (laboratory stock) were used for the generation of transgenic tobacco plants.
2. YEP medium (HiMedia) containing antibiotics streptomycin (HiMedia), rifampicin (Sigma), and kanamycin (HiMedia) were used for growing *Agrobacterium* (see Notes 5 and 6).
3. Cocultivation medium [MS salts, 2 % glucose, 10 mM MES, and 100 mM acetosyringone (3, 5-Dimethoxyacetophenone) pH 5.6] used for preparing *Agrobacterium* suspension and infection and prepared from Sigma Chemicals.
4. Antibiotics cefotaxime (HiMedia) and Augmentin (GlaxoSmithKline) were used for washing of cocultivated samples (see Notes 5 and 6).
5. In subsequent selection process of positive transformants, antibiotics hygromycin B (Sigma) and kanamycin (HiMedia) were used in media for pCAMBIA1300 and pBII01, respectively.
6. Regeneration media: MS salt, 3.0 % sucrose, 37.3 mg/L Na₂EDTA, 27.8 mg/l FeSO₄.7H₂O, 1.0 mg/L BAP, 0.1 mg/L NAA, 100 mg/L myoinositol, and 0.8 % agar (pH 5.8) for shoot induction and MS salt, 440 mg/l CaCl₂, 37.3 mg/l Na₂EDTA, 27.8 mg/l FeSO₄.7H₂O, 100 mg/l myoinositol, 3.0 % sucrose, and 0.7 % agar for root regeneration were used (see Notes 5 and 6).

2.5 Molecular Screening of Putative Transgenic Plant

1. DNeasy mini kit (Qiagen, Valencia, CA) was used for genomic DNA isolation from transgenic plant.
2. High-fidelity Taq polymerase from Sigma, St. Louis, MO, was used for PCR screening of transgenics (see Note 7).

- Each PCR reaction was carried out in 25 μ l, containing 200 mM of each dNTP, 0.2–0.5 μ g of genomic DNA, 1 mM of each primer, and 1.25U Taq DNA polymerase and PCR buffer contained 2 mM magnesium chloride.

2.6 Evaluation of Expressed Transgenic Protein

- Total soluble protein was estimated by Bradford reagent (Bio-Rad).
- Mono-sialoganglioside GM1, asialofectin (Sigma; St. Louis, MO) for quantitative analysis.
- Microtiter plate reader (Bio-Rad, USA), microtiter plate washer (PW-40, Bio-Rad), and 96-well microtiter plate Immulon 4HBX (Fisher, Pittsburgh, PA) were used for performing ELISA. pNPP (*p*-nitrophenyl phosphate disodium salt) substrate (Bangalore Genei, Bangalore) for ELISA is used. Alkaline phosphatase-conjugated anti-rabbit and anti-horse IgG (Sigma, St. Louis, MO) are used for both ELISA and Western blot analysis.
- The electrophoresis was carried out in Mini-Protean II Dual Slab Cell System (Bio-Rad).
- Bio-Rad Mini Trans-Blot Cell (SDS-PAGE), Hoefer Transphor™ apparatus (Native PAGE), 0.2 μ m ImmunoBlot® PVDF membrane (Bio-Rad), and alkaline phosphatase substrate color developer kit (Bio-Rad, Hercules, CA) were used for Western blot analysis.
- Nylon membrane (Hybond N⁺ membrane, Amersham Life Sciences) was used for transferring the digested genomic DNA. Radioactive chemicals [α -³²P] dCTP were purchased from BRIT (Board of Radiation and Isotope Technology, DAE). Phosphor imager (Molecular Imager FX, Bio-Rad, USA) was used for taking the image of X-ray films (*see Note 8*).
- Animal experiments were performed on BALB/c mice (five in each group) which were taken from animal house CDRI, Lucknow. Commercial rabies vaccine (Abhayrab, Indian Immunologicals) was used as positive control for immunization experiment.

3 Methods

3.1 In Silico Analysis of Fusion Proteins

- An alignment file of the amino acid sequences of ricin B chain, rabies glycoprotein, and hybrid was a prerequisite of Expasy server to produce hybrid model. This alignment file of ClustalW was submitted to Swiss-Model (<http://swissmodel.expasy.org>) and retrieved preliminary hybrid models of fusion proteins.
- MULTICOM protein tertiary structure prediction (http://www.molbiol-tools.ca/protein_tertiarystructure.html) server was used to generate PDB file of RGP-RTB fusion protein

which is based on homology-dependent tertiary structure of multiple templates.

3. To analyze the quality of the deduced model RAMPAGE: Ramachandran Plot Assessment tool was used (<http://mordred.bioc.cam.ac.uk/~rapper/rampage.php>). For superimposition study, openware software PyMOL was used (<http://www.pymol.org>) as per the developer instructions.
4. To determine Hopp-Woods hydrophilicity or water solubility of amino acids in a protein, Sci-Ed software (http://www.sci.ed.com/dl_cmb9d.htm) was used according to the developer's instruction (*see Note 9*).
5. Physicochemical property of protein was predicted through ProtParam analysis (<http://web.expasy.org/protparam>) [31].

3.2 Synthesis of Chimeric Fusion Gene

Because rabies glycoprotein and cholera toxin B chain genes belong to rabies virus and *Vibrio cholerae* bacteria, respectively, the need of their gene optimization for plant expression was necessary in comparison with plant (*Ricinus communis*) origin ricin toxin B chain.

1. Glycoprotein of rabies virus ERA strain and cholera toxin B chain of *Vibrio cholerae* 0139 strain 1854 were bioinformatically designed with different softwares according to the developer instructions for high expression in dicot plants [34, 35] (*see Notes 10–14*).
2. The whole sequence was synthesized as overlapping oligonucleotides.
3. The oligonucleotides were synthesized on Gene Assembler Special (Pharmacia Biotech, Sweden), purified on urea-PAGE.
4. Purified oligonucleotides were assembled into fragments by polymerase chain reaction as method described by Singh et al. [36].
5. The assembled fragments were cloned in pBluescript SK+ cloning vector (Stratagene, La Jolla, CA).
6. At least six clones were sequenced with ABI 377 DNA sequencer in each time to locate the possible errors in synthesis.
7. The error corrections were done through exchanging mutated regions with those from correct clones.
8. Finally, the error-free DNA fragments were stepwise ligated to give a full-length *rgp* and *ctxB* gene (Fig. 1).

3.3 Cloning into Plant Expression Vector

In earlier reports from our laboratory, we were not only able to design and clone plant codon-optimized synthetic *ctxB* gene of *Vibrio cholerae* [37] and *rgp* gene of rabies virus glycoprotein [14] but also successfully expressed them into tobacco leaves. But to generate a fusion gene product (*ctxB-rgp* and *rgp-rtxB*) of rabies glycoprotein for oral delivery of rabies antigen, we utilize altogether different strategy.

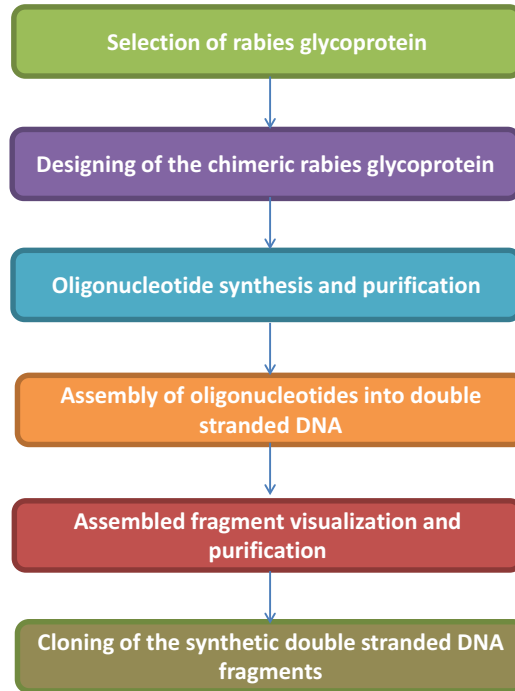

Fig. 1 Steps involved in gene designing and synthesis

1. The pr-s-ctxB fragment was PCR amplified by using forward primer (5'ACTCTAGAATGAACTTCCTCAAGTCCTTC3') and reverse primer (5'AGGCCCGGGACCGTTAGCCATGGAGATAG3') containing *Xba*I and *Sma*I site, respectively, through pSM31 plasmid [37]. The reverse primer also contained codons of glycine-proline hinge at the 3' end (*see Note 15*).
2. The synthetic glycoprotein gene was PCR amplified through pSA5 plasmid [14] by using forward primer (5'GGTCCCGGGCCTAAGTTCCTATCTACAC3') which contains *Sma*I site with codons of glycine-proline hinge and reverse primer (5'ACGAGCTCTCATCACAACCTCATCCTTCTC3') which contains *Sac*I site (*see Notes 16 and 17*).
3. Then, PCR amplified fragments were digested with the respective enzymes and triple ligated into pBI101 vector with enhanced CaMV35S promoter (pSA5) to obtain construct pSR1241 which contained two glycine-proline repeats as hinge at the 3' end of *ctxB* (Fig. 2a).
4. Approx.1.5 kb fragment of *rgp-gp* was amplified from pSA33 [14] by using RGP F1 (5'TCTCTCTGCTCGTCTGCTGTCGTCTCCGCTAAGTTCCTATCTACACTATC3') forward and RGP R1 (5'TGGCCCTGGCCCCTTACCCCAGTTGGGAGA3') reverse primer with glycine-proline hinge region.

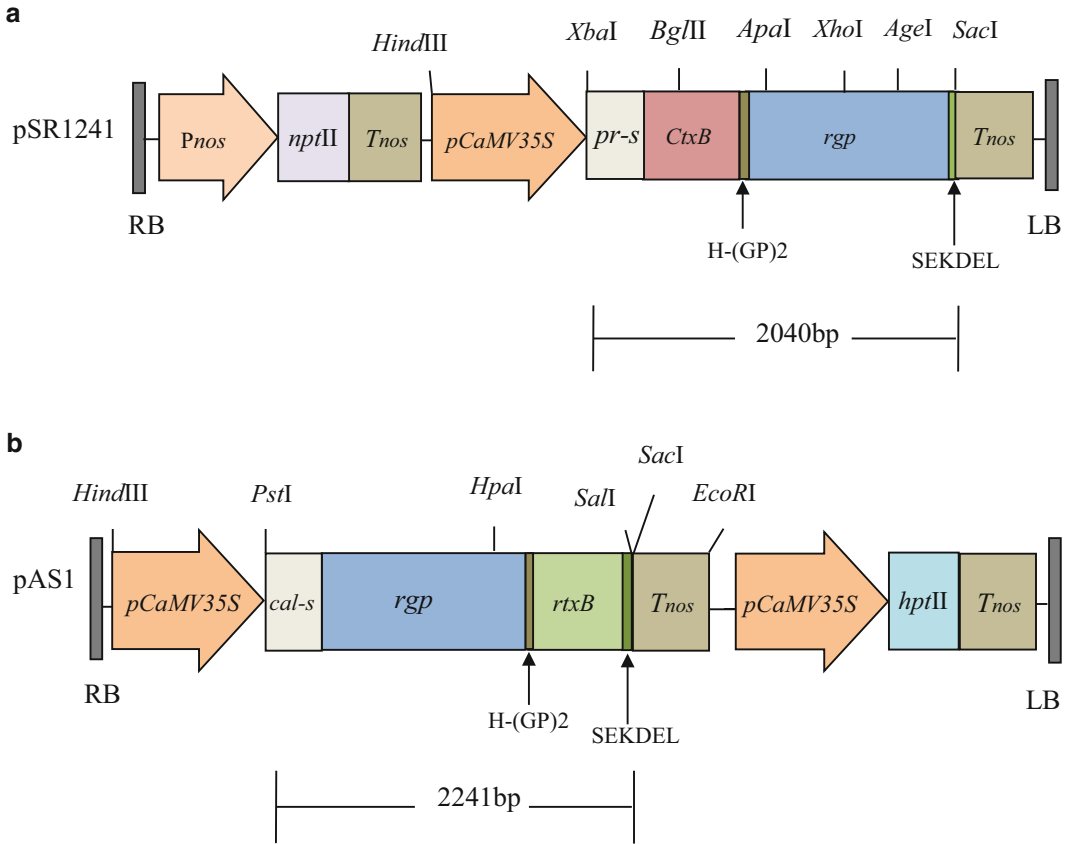

Fig. 2 (a) pSR1241 gene constructs showing cloning of the fusion gene *ctxB-rgp* in pBI101. (b) pAS1 gene construct showing cloning of the fusion gene *rgp-rtxB* in pCAMBIA1300

5. Tobacco calreticulin signal sequence was added into the amplified *rgp-gp* fragment through primer extension method by using Cal F1 (5'ACTGCAGAT GGCTACTCAACGAAG GGCAAACC3'), Cal F2 (5'CTACTCAACGAAGGG CAAAC CCATCTTCTCTTCACCTAATTACTG3'), Cal F3 (5'CATC TTCTC TTCACCTAATTACTGTATTCTCTCTGCTCGTC GCTGTC3') forward primers, and RGP R1 reverse primers.
6. The intronless *rtxB* gene was directly amplified from the genomic DNA of *Ricinus communis*. Forward primer ricin F1 (GTAAGGGGCCAGGGCCAGCTGATGTTTGTATGGA TCCT) which contains the sequences of glycine-proline hinge region and reverse primer ricin R1 (CATCCTTCTCGGAA AATAATGGTAACCATATTTGGTTTG) and ricin R2 (GCT CTAGATCAT CACAACCTCATCCTTCTCGGAAAATAATG) which contains the SEKDEL sequences were used to extent the *rtxB* gene at N and C terminal, respectively (*see Note 18*).

7. The fragment *cal-rgp-gp* (**step 7**) and *gp-rtxB-SEKDL* (**step 8**) was joined by overlapping assembly PCR method as described by Shevchuk et al. [38] and Young and Dong [39] (*see Note 19*).
8. The assembled *cal-rgp-gp-rtxB-SEKDL* gene was finally amplified with terminal Cal F1 forward and ricin R2 reverse primer which contains restriction sites *Pst*I and *Sac*I, respectively. Cycling parameters for amplification of whole gene from phusion polymerase were used: 98 °C for 2 min; 35 cycles of 98 °C for 20 s; 60 °C for 15 s, 72 °C for 30 s; 72 °C for 5 min.
9. After amplification of whole gene, PCR product was cleaned with PCR cleanup kit (Sigma) and ligated into *Eco*RV digested pBluescript SK⁺ for the sequencing and verification of proper assembly of whole gene.
10. CaMV35S double enhancer promoter was amplified from pCAMBIA1300 with CaMV1F (5'ATTTACTGAATTCCGCGTATTGGCTAGAGCAGCTTGCCACATGGTG3') forward and CaMV1R (5'TTCTGCAGAGAGATAGATTTGTAGAGAGAGAC3') reverse primer containing *Hind*III and *Pst*I sites, respectively.
11. The sequenced gene (**step 9**) and promoter were subcloned into pCAMBIA1300 at between *Pst*I to *Sac*I and *Hind*III to *Pst*I restriction sites, respectively.
12. Finally, *Tnos* fragment was isolated by digesting pBI121 with *Sac*I and *Eco*RI restriction enzymes and subsequently cloned into the same pCAMBIA1300 which contains promoter and whole gene to obtain pAS1 construct (Fig. 2b).

3.4 Generation of Transgenic Lines

1. *Agrobacterium tumefaciens* LBA4404 was transformed with pSR1241 and pAS1 by electroporation and used for tobacco (*Nicotiana tabacum* cv. Petit Havana) transformation by using leaf disc method [14, 40].
2. A single isolated colony of *A. tumefaciens* LBA 4404 (pAL4404) harboring binary vector pSR1241 and pAS1 was inoculated in YEP medium containing antibiotics streptomycin, rifampicin, kanamycin (pSR1241), and hygromycin B (pAS1) and grown overnight at 28 °C with shaking.
3. Fifty µl of the overnight culture was diluted to 100 ml in YEP medium and grown till OD₆₀₀ reached to 0.8.
4. Cells were recovered by centrifugation in SS34 rotor (7000 ×g, 10 min, 4 °C) and further suspended in cocultivation medium.
5. Tobacco seeds were in vitro grown on Hoagland's solution and further used in leaf disc transformation in subsequent process (*see Notes 20–23*).
6. Tobacco leaf discs were cocultivated with *Agrobacterium tumefaciens* for 2 days in dark at 25 °C.

7. After cocultivation, the leaf discs were washed together with cefotaxime (500 µg/ml), and Augmentin (500 µg/ml), twice for 10 min and dry on Whatman filter paper No.1 to remove residual water.
8. After blot dry, the leaf discs were transferred to regeneration medium supplemented with cefotaxime (250 µg/ml), kanamycin (100 µg/ml), or hygromycin B (30 mg/ml) accordingly and incubated in light (photoperiod 16/8) for a period of 4 weeks (*see Note 24*).
9. After getting transgenic shoot, it was excised and transferred to rooting medium containing kanamycin (50 µg/ml) or hygromycin B (15 mg/ml).
10. After incubation for 2–4 weeks, the putative transgenic plantlets were transferred to Hoagland's solution for acclimatization and then transferred to vermiculite for hardening (*see Note 25*).
11. Kanamycin-resistant T₀ plantlets of pSR1241 and hygromycin B-resistant T₀ hardened plantlets of pAS1 were transferred to pot containing soil and shifted to the greenhouse until these grow up to maturity or seed-setting stage.

3.5 Molecular Screening of Putative Transgenic Plants

1. DNA was isolated from transgenic leaves, hairy roots, and non-transgenic control leaves; roots were frozen in liquid nitrogen by using DNeasy mini kit (Qiagen, Valencia, CA).
2. Transgenic plants were screened through PCR for the presence of *ctxB-rgp* gene by using CTB FS1 (5'ATCGATGTCGACTA ACAACTTCCTC3') forward and CTB RS1 (5'AGATCGTC GACTCATCACAACCTCATC3') reverse primers with cycling parameters: 95 °C for 3 min; 35 cycles of 95 °C for 1 min; 60 °C for 1 min, 72 °C for 2 min; 72 °C for 5 min.
3. PCR screening of *rgp-rtxB* gene for putative transgenic plants was performed by using RGP FS1 (5'TCTCTCTGCTCGTCG CTGTC3') forward and ricin RS1 (5'CATCCTTCTCGGAAA ATAATGG3') reverse primers with cycling parameters: 95 °C for 3 min; 35 cycles of 95 °C for 1 min; 58 °C for 1 min, 72 °C for 2 min 15 s; 72 °C for 5 min (*see Note 26*).
4. The polymerase chain reaction was also performed to confirm the absence of *vir C* genes by using *vir C F* (5'ATCATTTGTAGCGACT3') forward primer and *vir C R* (5'AGCTCAAACCTGCTTC3') reverse primer in the transgenic and control lines (*see Note 27*).
5. Samples were subjected to 35 cycles of 1 min denaturation at 95 °C, 1 min annealing at 55 °C, and 1 min extension at 72 °C for the amplification of *vir C* (730 bp) fragments. Amplified DNAs were detected on 1 % (w/v) agarose gels.

3.6 Evaluation of Expressed Transgenic Protein

3.6.1 Enzyme-Linked Immunosorbent Assay (ELISA)

Indirect ELISA

1. A 96-well microtiter plate was coated with 100 μ l of total soluble protein of each transformed and non-transformed lines of tobacco leaves lysed in 20 mM Tris-Cl buffer (pH 8.0) (*see Note 28*).
2. The plates were incubated overnight at 4 °C or at 37 °C for 2 h and processed as per ELISA method described by Harlow and Lane [41].
3. The plate was blocked with 1.0 % BSA in PBST (0.01 M Na₂HPO₄, 0.003 M KH₂PO₄, 0.1 M NaCl, 0.05 % Tween-20 v/v, and pH 7.4).
4. Between any two incubations, the plates were washed with PBST three times with 2 min soak time on PW-40 plate washer.
5. After blocking, the plates were probed with the peptide antibody against RGP and equine anti-rabies polyclonal antibody (primary antibodies) at 1:5000 dilutions and incubated for 2 h in PBST containing 0.25 % BSA.
6. Plates were further incubated with ALP-conjugated anti-rabbit and anti-horse IgG in 1:20,000 dilutions for 2 h.
7. The wells were washed with 100 μ l pNPP (*p*-nitrophenyl phosphate disodium salt); a substrate (Bangalore Genei, Bangalore) was applied per well.
8. The reaction was stopped after 15 min by the addition of 50 μ l of 2 N NaOH. Absorbance ($A_{405\text{nm}}$) was read in a microplate reader (*see Note 29*).
9. Serially diluted *E. coli*-derived SUMO-RGP [42] in Tris-Cl buffer (pH 8.0), in concentrations ranging from 2.5 to 500 ng per well, was used for preparation of standard curve (*see Notes 30 and 31*).

Direct ELISA

GM1-Binding ELISA

Expression of *ctxB-ryfp* gene in leaves was determined by quantitative mono-sialoganglioside-dependent enzyme-linked immunosorbent assay (GM1-ELISA) as described by Roy et al. [19] (*see Note 28*).

1. Microtiter plates were coated with 3.0 μ g/ml GM1 made in sodium carbonate buffer, pH 9.6 (15 mM Na₂CO₃, 35 mM NaHCO₃), for 1 h.
2. Wells were then washed three times between each step using 300 μ l of PBST.
3. Then plate was blocked with 1.0 % BSA in PBST for 1 h at 37 °C.
4. Serially diluted 100 μ l of total soluble proteins from different samples was added into triplicate wells and incubated for 2 h at 37 °C.
5. Then follow further **steps 4–8** of Subheading “Indirect ELISA” for completing the experiment.

6. RGP expression level was quantified on a linear standard curve [42] (*see Note 29*).

Asialofeitin-Binding ELISA

The functionality of recombinant protein in the protein extracts of transgenic hairy root lines was determined via binding to asialofeitin [31].

1. Microtiter plates were coated with 200 μ l of asialofeitin which dissolved in bicarbonate buffer (pH 9.6) at concentration 100 μ g/ml for 2 h at room temperature (RT) (*see Note 28*).
2. The coating solution was discarded, and the wells were blocked with 300 μ l of 1 % BSA in PBST for 1 h at RT.
3. The blocking solution was discarded and washed thrice with PBST.
4. Then 100 μ l each of RTB standards (described below) and sample (prepared protein extracts) was applied in triplicate wells and incubated for 1 h at RT.
5. Then follow further **steps 4–8** of Subheading “Indirect ELISA” for completing the experiment.

3.6.2 Polyacrylamide Gel Electrophoresis of Plant Proteins

SDS-Polyacrylamide Gel Electrophoresis

Total soluble plant proteins were electrophoresed on denaturing polyacrylamide gel for further analysis.

1. The 10 % SDS-polyacrylamide gel was made from stock of acrylamide and bis-acrylamide solution (30 % w/v in a ratio 29:1). Composition of gel was made as described in Molecular Cloning: A Laboratory Manual [43].
2. The amount of 30 μ g extracted protein from transgenic, non-transgenic plants and a molecular weight markers mixed with equal volume of 2 \times gel loading buffer [glycerol 20 % (v/v); 0.1 M Tris-Cl, pH 6.8; 4 % SDS, 100 mM DTT and 0.2 % (w/v) bromophenol blue].
3. Protein samples were loaded directly on the gel with heat treatment or boiled for 5 min to dissociate oligomer into monomers.
4. The samples were centrifuged in microfuge (12,000 $\times g$, 5 min, 4 $^{\circ}$ C) and loaded on 10 % SDS-PAGE.
5. The electrophoresis was carried out in buffer (25 mM Tris-Cl, pH 8.8; 192 mM glycine and 0.1 % SDS) at constant current of 16 mA.

Native Polyacrylamide Gel Electrophoresis

1. The native state of CTB-RGP and RGP-RTB fusion protein was detected by using 6 % Native PAGE.
2. Unboiled (nonreduced) samples were loaded without adding DTT in sample loading buffer [44].
3. The gel was run at constant 30 V for at least 5 h and blotted into PVDF membrane by electro-blotting on Hoefer TransphorTM apparatus with cooling (*see Notes 32 and 33*).

3.6.3 Western Blot Analysis

Samples were mixed with equal volume of sample loading buffer (25 mM Tris-Cl, pH 6.8, 2 % SDS, 200 mM DTT, 20 % glycerol, and 0.25 % bromophenol blue), immediately boiled in a water bath for 5 min and centrifuged at $13,000 \times g$.

1. The supernatant was electrophoresed on a 10 % Tris-acrylamide gels, a discontinuous SDS-PAGE in mini-gel apparatus (Bio-Rad, Hercules, CA), and transferred to 0.2 μm ImmunoBlot® PVDF membrane (Bio-Rad) in blotting buffer (25 mM Tris-base, 192 mM glycine, and 20 % methanol) (*see Note 34*).
2. All washings, blocking, and antibody dilutions were made in TBS-T buffer (100 mM Tris pH 7.5, 150 mM NaCl, 0.1 % Tween 20).
3. The membrane was blocked with 5 % nonfat dry milk powder (Bio-Rad) for 1 h, followed by incubation with the designated primary antibody in blocking solution for further 2 h.
4. Membranes were washed three times for 5 min each with TBS-T buffer and incubated with secondary antibody for 2 h and washed 3 times as above.
5. The primary and secondary antibodies were used at 2000-fold and 10,000 dilutions, respectively, and the blot was developed with AP substrate color developer kit (Bio-Rad, Hercules, CA) (*see Note 35*).

3.6.4 Southern Blot Analysis of Transgenic Plants

The genomic DNA was isolated from mature tissue following modified CTAB method. The following steps were performed for this purpose [14]:

1. One gram of fresh tissue was ground to fine powder in liquid nitrogen. The quantity of 12 ml CTAB extraction buffer (2 % w/v CTAB; 50 mM Tris-base, 20 mM EDTA, 1.4 NaCl, and 0.1 % v/v, β -ME) was added to powdered tissue and homogenized properly by intermittent short vortexing.
2. The mixture was kept at 68 °C for 2 h for lysis. After incubation, the temperature of lysate was brought down to the room temperature.
3. The lysate was extracted with 0.7 volume chloroform: isoamyl alcohol.
4. The aqueous layer was collected in a fresh tube after centrifugation (SS34 rotor, $13,000 \times g$, 10 min, 22 °C).
5. The nucleic acids were precipitated with 0.7 volume isopropanol by keeping on ice for 10 min and then recovered by centrifugation.
6. The pellet was washed with 70 % ethanol and dried at room temperature. The nucleic acids containing genomic DNA were dissolved in 750 μl of 10 mM Tris-Cl, pH 7.4 containing DNase free RNase A (50 $\mu\text{g}/\text{ml}$) and transferred to micro-centrifuge tubes.

7. The micro-centrifuge tubes were kept overnight at 37 °C to carry out RNA digestion.
8. The genomic DNA was extracted once with phenol/chloroform/isoamyl alcohol (25:24:1) and twice with chloroform/isoamyl alcohol (24:1).
9. DNA was precipitated with 0.7 volume isopropanol, dried in air, dissolved in water, and quantified on spectrophotometer.
10. At least 20 µg genomic DNA was digested with *Xho* I restriction enzymes in 300 µl reaction mixture, 5 U/µg restriction enzyme was used in two steps, and digestion was carried out for 16 h (*see* **Notes 36** and **37**).
11. Digested genomic DNA was loaded on 0.8 % agarose gel and resolved completely (*see* **Notes 38–40**).
12. After electrophoresis, the agarose gel was washed with sterile water and placed in 0.25 M HCl for 20 min to complete the depurination process.
13. The DNA of the gel was transferred to positively charged nylon membrane (Hybond N⁺ membrane, Amersham Life Sciences) with 20× SSC as transfer buffer following capillary blot method as instructed by the manufacturer and discussed by Sambrook et al. [**43**].
14. After the transfer, membrane was washed with 2× SSC buffer, wrapped in Saran wrap, and stored at 4 °C.
15. Hybridization was performed at 65 °C for 16 h, using [^αP³²] dCTP-labeled probe, comprising 570 bp of *Xho* I-*Age* I and 519 bp of *Eco*R V-*Hpa* I fragment at 3' end of *ctxB-rgp* and *rgp-rtxB* genes, respectively.
16. The membrane was exposed to Fuji screen for 24 h and scanned on phosphor imager (Molecular Imager FX, Bio-Rad, Hercules, USA).

3.6.5 Animal Immunization Experiment

Immunization assay of BALB/c mice was performed to check the efficacy of CTB-RGP and RGP-RTB fusion protein by method described by Singh et al. [**31**].

1. To reduce the background of other proteins, CTB-RGP and RGP-RTB fusion proteins were partially purified by using 30–60 % range of ammonium sulfate precipitation.
2. Precipitated protein was dissolved in PBS buffer and dialyzed overnight against PBS buffer.
3. BALB/c mice (five in each group) were orally primed by 50 µg of each extracted and partially purified CTB-RGP; RGP-RTB fusion proteins along with phosphate buffer saline were used as a negative control (*see* **Notes 41–43**).

4. Then, three booster doses of 25 μg were given on the 7th, 14th, and 28th day. Serum was collected after 7 days from the third booster means on 35th days.
5. The minimum 25 μg of each mucosal adjuvant (CTB and RTB) was mixed with 25 μg of attenuated viral vaccine (Abhayrab, Indian Immunologicals) and given orally to individual mice of respective group as a control.
6. The mice were bled on the 35th day, from the retro-orbital sinus for the estimation of anti-rabies antibody titer in serum.
7. The microtiter plates were incubated with 100 μl /well of the commercial virus-based vaccine (Abhayrab, Indian Immunologicals) at the dilution of 1:50 in PBST buffer containing 0.25 % BSA at 4 °C for 2 h.
8. Then plates were again washed with PBST buffer.
9. The washed microtiter plates were further filled with 100 μl well of serum (1:100) of different groups of mice and incubated for 2 h at 4 °C.
10. The plates were then washed and incubated with horseradish peroxidase conjugated anti-mouse anti-IgG1 (1:1000) and anti-mouse anti-IgG2a (1:1000) in PBST containing 0.25 % BSA at 37 °C for 2 h.
11. For the chromogenic development, tetramethylbenzidine was used for 30 min at 37 °C. The enzymatic reactions were stopped by adding 50 μl of 1 N sulfuric acid per well. Absorbance was measured at 450 nm.

4 Notes

1. If knowledge of interacting receptor of protein and their tertiary structure is available, then docking study of receptor-protein interaction can also be done.
2. Use more than one software or tool for optimization and designing of genes to determine the best fit model and verify synchronization of output result of different software algorithms.
3. All the restriction enzyme and T4 DNA ligase were purchased from New England Biolabs.
4. Amplification of the long assembled fragment was carried out by high-fidelity proofreading enzyme phusion polymerase (Finzyme).
5. The entire chemicals which were used in plant tissue culture should be pretested for plant tissue culture and of high quality as given by Sigma and HiMedia for optimization to get optimum result at every time.
6. Every batch of chemicals used should be consistent. The chemicals should be from the same vendor and should not be

substituted with chemicals from other vendor's midway of tissue culture to avoid any discrepancies.

7. Bio-Rad DNA Engine Tetrad 2 Peltier Thermal Cycler was used for PCR in both cloning and screening of transgenics.
8. All the restriction enzymes which were used in cloning and genomic DNA digestion were procured from New England Biolabs.
9. Water solubility and hydrophobicity index determine the surface exposure of amino acids which is important to predict their antigenic importance.
10. Plant-preferred translation initiation context TAAACAATG and codon-optimized double-stranded DNA were used.
11. The CG ending of codons should be avoided because it could provide sites for methylation.
12. The codons ending with TA are energetically less stable and often not used in plants and, hence, should be avoided.
13. The transcription termination signals (AAUAAA) and mRNA instability element (ATTTA) should be eliminated.
14. Potential splice sites and long hairpin loops should be avoided [14].
15. The signal sequences, PR-S of the pathogenesis-induced tobacco protein PR-1a [45], and Cal-S of ER-resident tobacco protein calreticulin [46] were used to facilitate the transport of the fusion protein to endoplasmic reticulum.
16. A glycine-proline hinge was used at the fusion point of translational frames of the CTB-RGP and RGP-RTB fusion proteins.
17. Glycine-proline hinge (GP)₂ was used to give sufficient space for independent folding of both the fusion partner and fusion protein without creating steric hindrance for each other [47].
18. ER retention signal SEKDL was used to retrieve back the fusion protein after processing from Golgi apparatus and retain in ER further [48].
19. Fusion of two long genes through overlapping PCR amplification is very hard to achieve in one time. We imply three step strategies to resolve this problem. If we are trying to fuse two amplified genes A and B, then first amplify the gene A with overlapping primer of B sequence to fuse smaller segment of B (say B') which create A-B' fusion product. In the second step find one unique restriction site which present at smaller segment of B' sequence. Then restrict both the fragment, fused sequence of A - B' as well as sequence of whole B gene with same restriction enzyme to create compatible sticky end and purify the fragments through Qiagen DNAeasy gel elution kit. In last third step, ligate both the fragments with NEB T4 DNA

ligase to create complete whole gene (A–B) and then amplify the whole gene with terminal primers through proofreading containing high-fidelity phusion polymerase (Finzyme).

20. Before growing in vitro, tobacco seeds were sterilized with 1.0 % sodium hypochlorite (NaOCl) for 5 min and then washed three times with water.
21. After blot dry seeds were placed on Petri plates (Greiner) which contained Whatman filter paper as disc with Hoagland for further germination.
22. Use bow-shaped autoclaved blotting sheet in large test tube for further transfer and growing of the tobacco plantlets.
23. Leaves of in vitro grown tobacco were already sterilized and hence directly cut into small pieces and used further for leaf disc transformation assay.
24. At least use three selection cycles of antibiotics to ensure the transformation and to avoid the chimera formation.
25. Tobacco plantlets with initiated primary roots developed their root system more rapidly when shifted to nutrient-deficient media like ½ MS with ½ sucrose concentration for a week and then hardened at Hoagland solution.
26. For PCR screening, always use DNA of non-transformed plant and positive plasmid as a negative and positive control, respectively.
27. Because the amplified product of transgene can also come through transfected Agrobacterium contamination, so the need of negative control was arise. Hence, amplification of vir C should be checked as a negative control, because gene vir C is a part of vir operon which is only present in Agrobacterium.
28. Microtiter plate should have medium capacity for binding hydrophobic domains to reduce the background.
29. Standard samples should be made with serial dilutions of target antigen to achieve straight line.
30. Chromogenic substances are light and temperature sensitive; hence, plates should be covered with aluminum foil and kept into 37 °C for 10–20 min to get optimum result.
31. Optimize incubation timing and do not overincubate the plates for color development which may create variation in the readings.
32. Due to the folding of the proteins, the size of the protein usually appears larger in native PAGE as compared to SDS-PAGE. Hence, this impose extra resistance on the mobility of the protein subsequently which takes more time for resolving on the gel as well as for complete transferring to the blot in Western blot analysis.

33. The continuous cooling of running and transfer buffer is a prerequisite of native PAGE.
34. It is a general practice to load higher amount (>50–60 µg/lane) of total soluble protein on PAGE for recognizing less expressed proteins, but by loading higher amount, we can distort the appearance of protein band on blot. Centrifugation of samples at $13,000 \times g$ for 5 min can reduce the background impurities and improve the probability of recognition of desired protein from antibodies.
35. Dilution of antibodies can be varied from batch to batch even within one manufacturer; hence, every new batch should be cautiously used and optimized accordingly.
36. Cut the tip of micro-tips for efficient handling of the genomic DNA and avoidance of shearing.
37. Enzyme gets exhausted within 8 h during digestion; hence, for completion, the digestion extra units were added after 8 h of reaction and mixed with the enzyme by swirling the solution with micro-tips.
38. Before running the final 0.8 % agarose gel, digested genomic DNA should be checked on mini-gel agarose to confirm complete digestion.
39. Agarose at 0.8 % is fragile in nature so be very careful during the holding and transferring process.
40. Use TAE buffer for running and making the agarose gel for efficient transfer of digested DNA fragments to Hybond N+ membrane, and transfer is to be carried out overnight.
41. At least five mice should be taken in each group so that statistical analysis can be made possible between them.
42. Before giving the oral dose, BALB/c mice should be fasted overnight for efficient oral feeding.
43. A cannula which fitted on graduated syringe should be used for accurate delivery of doses.

References

1. Mason H, Haq T, Clements J, Arntzen C (1998) Edible vaccine protects mice against *Escherichia coli* heat-labile enterotoxin (LT): potatoes expressing a synthetic LT-B gene. *Vaccine* 16:1336–1343
2. Tacket CO, Mason HS, Losonsky G, Estes MK, Levine MM, Arntzen CJ (2000) Human immune responses to a novel Norwalk virus vaccine delivered in transgenic potatoes. *J Infect Dis* 182:302–305
3. Daniell H, Streatfield SJ, Wycoff K (2001) Medical molecular farming production of antibodies, biopharmaceuticals and edible vaccines in plants. *Trends Plant Sci* 6:219–226
4. Webster DE, Thomas MC, Strugnell RA, Dry IB, Wesselingh SL (2002) Appetising solutions: an edible vaccine for measles. *Med J Aust* 176:434–437
5. Meslin FX, Stohr K (1997) Prospects of immunization against rabies in developing countries.

- In: Dodet B, Meslin FX (eds) Rabies control in Asia. Elsevier, Paris, pp 15–18
6. Pasteur L (1885) Méthode pour prévenir la rage après morsure. *Compt Rendus Acad Sci (Paris)* 17:765–774
 7. Perrin P, Lafon M, Sureau P (1990) Rabies vaccines from Pasteur's time up to experimental subunit vaccines today. *Adv Biotechnol Process* 14:325–345
 8. Plotkin S (1993) Vaccination in the 21st century. *J Infect Dis* 168:29–37
 9. Cox JH, Dietzschold B, Schneider LG (1977) Rabies virus glycoprotein II: biological and serological characterization. *Infect Immun* 16:754–759
 10. Curtiss R, Cardineau GA (1990) Oral immunization by transgenic plants. *World Patent Application*. WO 90/02484
 11. Mason HS, Lam DMK, Arntzen CJ (1992) Expression of hepatitis B surface antigen in transgenic plants. *Proc Natl Acad Sci U S A* 89:11745–11749
 12. Tiwari S, Mishra DK, Roy S, Singh A, Singh PK, Tuli R (2009) High level expression of a functionally active cholera toxin B: rabies glycoprotein fusion protein in tobacco seeds. *Plant Cell Rep* 28:1827–1836
 13. McGarvey PB, Hammond J, Dienelt MM, Hooper DC, Fu ZF, Dietzschold B (1995) Expression of the rabies virus glycoprotein in transgenic tomatoes. *Biotechnology* 13:1484–1487
 14. Ashraf S, Singh PK, Yadav DK, Shah Nawaz M, Mishra S, Sawant SV, Tuli R (2005) High level expression of surface glycoprotein in tobacco and its immunoprotective activity in mice. *J Biotechnol* 119:1–14
 15. De Aizpurua HJ, Russell-Jones GJ (1988) Oral vaccination: identification of classes of proteins that provoke an immune response upon oral feeding. *J Exp Med* 167:440–451
 16. McKenzie SJ, Halsey JF (1984) Cholera toxin B subunit as a carrier protein to stimulate a mucosal immune response. *J Immunol* 133:1818–1824
 17. Holmgren J, Lonnroth I, Mansson J-E, Svennerholm L (1975) Interaction of cholera toxin and membrane GM1 ganglioside of small intestine. *Proc Natl Acad Sci U S A* 72:2520–2524
 18. Nashar TO, Webb HM, Eaglestone S, Williams NA, Hirst TR (1996) Potent immunogenicity of the B subunits of *Escherichia coli* heat-labile enterotoxin: receptor binding is essential and induces differential modulation of lymphocyte subsets. *Proc Natl Acad Sci U S A* 93:226–230
 19. Roy S, Tyagi A, Tiwari S, Singh A, Singh PK, Sawant SV, Tuli R (2010) Rabies glycoprotein fused with B subunit of cholera toxin is expressed at high level in tobacco plants and folds into biologically active pentameric protein. *Protein Expr Purif* 70:184–190
 20. Tiwari S, Verma PC, Singh PK, Tuli R (2009) Plants as bioreactors for the production of vaccine antigens. *Biotechnol Adv* 27:449–467
 21. Yu J, Langridge WHR (2001) A plant-based multicomponent vaccine protects mice from enteric diseases. *Nat Biotechnol* 19:548–552
 22. Medina-Bolivar F, Wright R, Funk V, Sentz D, Barroso L, Wilkins TD, Petri W, Cramer CL (2003) A non-toxic lectin for antigen delivery of plant-based mucosal. *Vaccines* 21:997–1005
 23. Endo Y, Tsurugi K (1988) The RNA N-glycosidase activity of ricin A-chain. *J Biol Chem* 263:8735–8739
 24. Lambert JM, Goldmacher VS, Collision AR, Nadler LM, Blattler WA (1991) An immunotoxin prepared with blocked ricin: a natural plant toxin adapted for therapeutic use. *Cancer Res* 51:6236–6242
 25. Falnes P, Sandvig K (2000) Penetration of protein toxins into cells. *Curr Opin Cell Biol* 12:407–413
 26. Chazaud B, Muriel MP, Wantyghem J, Aubery M, Decastel M (1995) Ricin toxicity and intracellular routing in tumoral HT-29 cells. *Exp Cell Res* 221:214–220
 27. Tagge EP, Chandler J, Harris B, Czako M, Marton L, Willingham MC, Burbage C, Afrin L, Frankel AE (1996) Prepro-ricin expressed in *Nicotiana tabacum* cells in vitro is fully processed and biologically active. *Protein Expr Purif* 8:109–118
 28. Tonevitsky A, Toptygin A, Agapov I, Pfueller U, Frankel A (1994) Renatured ricin toxin B chain made in *Escherichia coli* is soluble, stable and biologically active. *Biochem Mol Biol Int* 32:1139–1146
 29. Wales R, Richardson P, Roberts L, Woodland H, Lord J (1991) Mutational analysis of the galactose binding activity of recombinant ricin B chain. *J Biol Chem* 266:19172–19179
 30. Choi NW, Estes MK, Langridge WH (2006) Mucosal immunization with a ricin toxin B subunit-rotavirus NSP4 fusion protein stimulates a Th1 lymphocyte response. *J Biotechnol* 121:272–283
 31. Singh A, Verma PC, Srivastava S, Chouksey A, Roy S, Singh PK, Saxena G, Tuli R (2015) Expression of Rabies glycoprotein and Ricin toxin B chain (RGP-RTB) fusion protein in tomato hairy roots: a step for Oral Vaccination for rabies. *Mol Biotechnol* 57(4):359–370

32. Jefferson RA, Kavanagh TA, Bewan MW (1987) β -glucuronidase as a sensitive and versatile gene fusion marker in higher plants. *EMBO J* 6:3901–3907
33. Kay R, Chan A, Daly M, McPherson J (1987) Duplication of CaMV35S promoter sequences creates a strong enhancer for plant genes. *Science* 236:1299–1302
34. Joshi CP (1987) An inspection of the domain between putative TATA box and translation start site in 79 plant genes. *Nucleic Acids Res* 15:6643–6653
35. Sawant SV, Singh PK, Gupta SK, Madnala R, Tuli R (1999) Conserved nucleotide sequences in highly expressed genes in plants. *J Genetics* 78:123–131
36. Singh PK, Sarangi BK, Tuli R (1996) A facile method for the construction of synthetic genes. *J Biosci* 21:735–741
37. Mishra S, Yadav DK, Tuli R (2006) Ubiquitin fusion enhances cholera toxin B subunit expression in transgenic plants and the plant-expressed protein binds GM1 receptors more efficiently. *J Biotechnol* 127:95–108
38. Shevchuk NA, Bryksin AV, Nusinovich YA, Cabello FC, Sutherland M, Ladisch S (2004) Construction of long DNA molecules using long PCR-based fusion of several fragments simultaneously. *Nucleic Acids Res* 32:e19
39. Young L, Dong Q (2004) Two-step total gene synthesis method. *Nucleic Acids Res* 32:e59
40. Horsch RB, Fry JE, Hoffmann NL, Eicholtz D, Rogers SG, Fraley RT (1985) A simple and general method for transferring genes into plants. *Science* 227:1229–1231
41. Harlow E, Lane D (1988) *Antibodies: a laboratory manual*. Cold Spring Harbor Laboratory Press, Cold Spring Harbor, NY
42. Singh A, Yadav D, Rai KM, Srivastava M, Verma PC, Singh PK, Tuli R (2012) Enhanced expression of rabies virus surface G-protein in *Escherichia coli* using SUMO fusion. *Protein J* 31:68–74
43. Sambrook J, Fritsch EF, Maniatis T (1989) *Molecular cloning: a laboratory manual*. Cold Spring Harbor Laboratory Press, Cold Spring Harbor, NY
44. Areas AP, Oliveira ML, Miyaji EN, Leite LC, Aires KA, Dias WO, Ho PL (2004) Expression and characterization of cholera toxin B-pneumococcal surface adhesin A fusion protein in *Escherichia coli*: ability of CTB-PsaA to induce humoral immune response in mice. *Biochem Biophys Res Commun* 321(1):192–6
45. Sijmons PC, Dekker BMM, Schrammeijer B, Verwoerd TC, van den Elzen PJM, Hoekema A (1990) Production of correctly processed human serum albumin in transgenic plants. *Biotechnology* 8:217–221
46. Denecke J, Carlson L, Vidal S, Holund A, Ek B, Zeijl M, Sinjorgo K, Palva T (1995) The tobacco homolog of mammalian calreticulin is present in protein complexes *in vivo*. *Plant Cell* 7:391–406
47. Arakawa T, Yu J, Chong DK, Hough J, Engen PC, Langridge WH (1998) A plant-based cholera toxin B subunit-insulin fusion protein protects against the development of auto-immune diabetes. *Nat Biotechnol* 16:934–938
48. Schouten A, Roosien J, van Engelen FA, de Jong GAM, Borst-Vrens AW, Zilverentant JF (1996) The C-terminal KDEL sequence increases the expression level of a single-chains antibody designed to be targeted to both cytosol and the secretory pathway in transgenic tobacco. *Plant Mol Biol* 30:781–793

Chapter 37

Purification of Virus-Like Particles (VLPs) from Plants

Albertha R. van Zyl and Inga I. Hitzeroth

1 Introduction

Viral coat proteins expressed in plants very often self-assemble and form virus-like particles (VLPs). VLPs have been shown to make excellent vaccine candidates [1, 2]. One important factor of VLP vaccines is that they are safe as they only contain the viral capsid proteins, with no viral genomic material, and they mimic the native virion in antigenicity. Many VLP vaccine candidates such as Hepatitis B (HBV), Norwalk virus (NV) and human papillomavirus (HPV) have been produced in plants and many of those have been shown to be safe and efficacious [3, 4]. One challenge that remains in plant-produced vaccines is purification of the expressed proteins. VLPs in general are more stable against degradation and can be isolated from plants utilizing centrifugation techniques similar to those developed for purification of plant viruses. VLPs can be separated and purified utilizing density gradient centrifugation that is either based on the buoyant density of the VLP and called isopycnic centrifugation or depends on the size and sedimentation coefficient of the VLP and is called rate-zonal centrifugation [5]. Either sucrose, which is relatively cheap and easy to handle, or iodixanol (OptiPrep™; <http://www.axis-shield-density-gradient-media.com/virusindexes.htm>) can be used in density gradient centrifugation. For most post-purification analysis such as gel electrophoresis, electron microscopy, or studies on cell culture, sucrose must be dialyzed before use, but most analysis can be performed without dialysis if the VLPs are purified in iodixanol.

Rate zonal centrifugation can be used to separate VLPs of different sizes by centrifugation through a steep density gradient, e.g., 5–20 % or 10–40 % sucrose, where the density at no point in the gradient exceeds that of the VLPs to be purified. Rate zonal centrifugation separation of VLPs is based on their size and rate of

sedimentation and not so much their density and it is mainly used for analytical purposes where the VLPs are as much separated from other components as possible, but it also results in lower yields. VLPs of different sizes will sediment to different places in the gradient.

With isopycnic centrifugation, separation of VLPs is based entirely on their buoyant density. The densest part of the gradient exceeds the density of the VLPs to be purified, and therefore the VLPs will never pellet. VLPs of a particular density will travel down the gradient until the point is reached where their density is the same as that of the gradient—an equilibrium position. Different sizes of the VLPs will only influence the rate at which the VLPs reach their equilibrium position. With this method one is able to purify VLPs of different sizes but with the same density and in general this method has fewer steps and can be used for preparative purposes as yields obtained are greater.

In this chapter we describe how to purify VLPs from plants utilizing rate-zonal and isopycnic centrifugation.

2 Materials

Wear the relevant personal protective equipment (PPE) and follow disposal regulations when disposing of waste material and sharps.

2.1 Media and Solutions

1. Sucrose or OptiPrep™ (*see Note 1*).
2. Appropriate extraction and purification buffer (s).
3. Sucrose and OptiPrep™ solutions can be made to the desired concentrations in the extraction/purification buffer of choice.

Example:

1. 20 % sucrose solution: add 20 g sucrose to 60 mL of the relevant buffer. The solution should be mixed until all the sucrose is dissolved. Fill the volume to 100 mL with buffer. The solution can be used as is immediately or filter-sterilized for later use (*see Note 2*).
2. 50 % OptiPrep™ solution: To make a 100 mL solution add 83 mL OptiPrep™ to 17 mL sterile buffer in a sterile conical tube and mix thoroughly (*see Note 3*).

2.2 Equipment Required

1. PPE.
2. Waring-type blender.
3. Miracloth™ (Merck).
4. 38.5 mL Thinwall Ultra-Clear™ open top ultracentrifuge tubes (Beckman).

5. 5 or 10 mL syringes.
6. 21 Gauge needles.
7. Ultracentrifuge.
8. Appropriate swinging-bucket rotor (*see* **Notes 4** and **5**).
9. Retort stand.
10. Optional: dialysis tubing.
11. Parafilm®.
12. Microcentrifuge tubes.
13. Refractometer.
14. Optional: two-chamber gradient maker.
15. Optional: fractionator.

3 Methods

3.1 Protein Extraction from Plants

Leaves can be processed in two ways—see A and B, **steps 1** and **2** below. From **step 3** onward extracted material from both methods are treated in the same way.

A:

1. Grind pre-weighed leaves with a mortar and pestle in the presence of liquid nitrogen until a fine powder is formed.
2. Add 3 volumes (*see* **Note 6**) of the relevant extraction buffer.

OR

B:

1. If you do not wish to freeze the leaves, they can be cut up in small pieces after which 3 volumes of the relevant extraction buffer is added.
2. Thoroughly homogenize the leaf/buffer mixture with a Waring-type blender (*see* **Note 7**).
3. Place the crude plant extract in a sealable container and shake gently at 4 °C for at least 1 h to facilitate protein extraction.
4. Filter the crude plant extract through at least two layers of Miracloth™.
5. Clarify the crude plant extract by centrifuging at 15,000 × *g* for 10 min at 4 °C.
6. Decant the supernatant into a fresh centrifuge tube and centrifuge again as in **step 5** above.
7. The clarified crude extract is now ready for purification.

3.2 Concentrating Protein on Sucrose/ OptiPrep™ Cushion with Ultracentri- fugation

The clarified crude extract can be centrifuged through a sucrose cushion if the VLPs/proteins have to be concentrated prior to

gradient centrifugation (*see Note 8*). VLPs can also be pelleted by centrifugation through a sucrose cushion.

1. Prepare the relevant volume of a 20 % sucrose solution (the volume will depend on how many samples/tubes are to be used for centrifugation).
2. Pipette (*see Note 9*) 5 mL 20 % sucrose into 38.5 mL Thinwall Ultra-Clear™ ultracentrifuge tubes.
3. Without disrupting the sucrose cushion, pipette the clarified crude plant sap (~33 mL) into the tube. Fill the tubes completely, with the meniscus about 1–2 mm from the top of the tube (*see Note 10*).
4. Place the filled centrifuge tubes in the relevant rotor buckets and balance (*see Note 11*).
5. When using a swing bucket rotor all the rotor buckets, whether they are loaded or empty, should be attached to the rotor.
6. Follow the rotor/centrifuge instructions carefully and lower the rotor down onto the drive hub of the centrifuge.
7. Centrifuge for the appropriate amount of time at the relevant speed to pellet VLPs (*see Note 12*) or to collect VLPs in the sucrose cushion (*see Note 13*).
8. After centrifugation remove tubes from the rotor buckets (*see Note 14*).
9. If the VLPs were pelleted, decant the supernatant and resuspend the pellet in the relevant buffer and analyze.
10. If VLPs were collected in the 20 % sucrose cushion: Clamp the centrifuge tube in a retort stand, make sure it is stable.

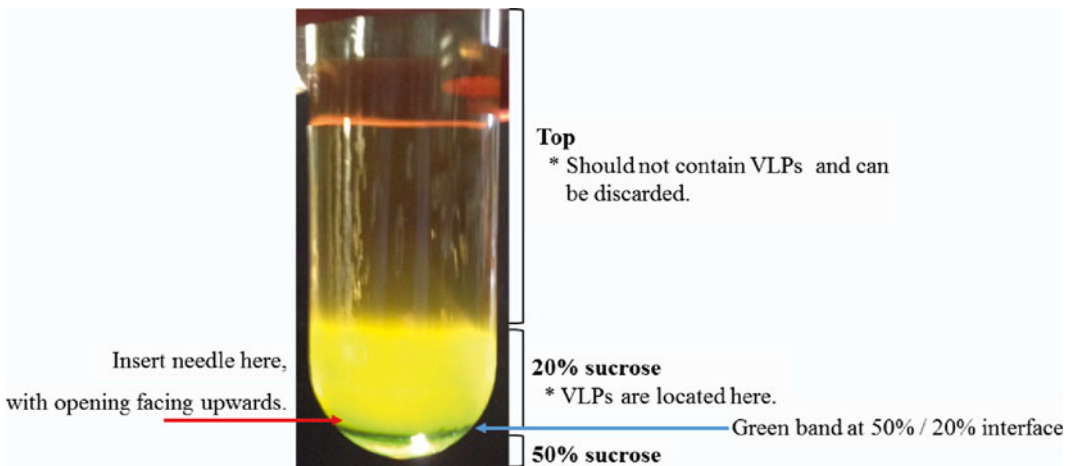

Fig. 1 Image of a 20 % sucrose cushion underlayered with 50 % sucrose after centrifugation of the clarified crude plant extract. The *red arrow* indicates where to insert the needle after centrifugation to facilitate collection of the 20 % cushion containing the VLPs

11. A dark green band (*see Note 15*) should be visible in the tube at the 50 %–20 % sucrose interface. About 1 mm above the green band, puncture a hole in the side of the tube with a 21 gauge needle and insert needle in the tube (Fig. 1).
12. Attach a 5 mL syringe to the needle.
13. Aspirate the 5 mL 20 % cushion directly above the green band by pulling back on the plunger of the syringe.
14. The liquid remaining in the centrifuge tube can be analyzed with SDS-Page/Western blotting and transmission electron microscopy (TEM) to ascertain that it contains no VLPs. Once the method is established, the liquid remaining after aspiration of the sucrose cushion can be discarded.
15. Dialyze the 20 % sucrose sample in an excess extraction/purification buffer overnight at 4 °C or dilute 1:2 in extraction/purification buffer to facilitate removal or dilution of sucrose from the sample prior to loading onto continuous/discontinuous gradients (*see Note 16*).

3.3 Gradient Preparation

AXIS-SHIELD has a very helpful website (<http://www.axis-shield-density-gradient-media.com/virusindexes.htm>) that shows various methods/techniques for preparing preformed continuous and discontinuous gradients.

3.3.1 Rate Zonal Centrifugation

For rate zonal centrifugation a steep, continuous gradient is required.

1. If a two-chamber gradient maker is available, follow the user manual instructions carefully to make 5–20 % or 10–40 % continuous gradients.
2. If no gradient maker is available a step- or discontinuous gradient can be prepared which will be left to diffuse giving rise to the continuous gradient.
 - (a) Prepare sucrose solutions that increase in steps of 5–10 % sucrose, i.e., 5 %, 10 %, 15 % etc. (*see Note 17*).
 - (b) A steep gradient (10–40 %) is important for separation of VLPs, the amount of sample loaded onto the gradient should not exceed 10–20 % of the volume of the gradient. Thus if the gradient volume is 30 mL the sample volume should be 3–6 mL in total.
 - (c) By either underlayering or overlaying (<http://www.axis-shield-density-gradient-media.com/virusindexes.htm>) add equal volumes of the sucrose steps in ultracentrifuge tubes.
 - (d) Seal the tube with Parafilm® or a plastic stopper and allow the gradient layers to diffuse overnight at 4 °C (*see Note 18*).
3. Gently overlay the dialyzed sample (from Subheading 3.2 above) onto the continuous gradient. Fill the tubes completely, with the meniscus about 1–2 mm from the top of the tube.

3.3.2 *Isopycnic Centrifugation*

For isopycnic centrifugation discontinuous gradients can be used to allow for selection of VLPs based on their density. Discontinuous gradients can be linear, convex, or concave where the volumes of the different gradient steps can be increased or decreased (<http://www.axis-shield-density-gradient-media.com/virusindexes.htm>) to enrich for VLPs of a certain density (*see Note 19*).

1. Prepare sucrose or OptiPrep™ gradient steps as required for the VLP to be purified (*see Note 20*).
2. Pour the gradient steps by either underlayering or overlayering—the volumes of each step can be adjusted to make linear, convex, or concave gradients.
3. Gently overlay either the clarified, crude plant extract (from Subheading 3.1 above) or the dialyzed sample (from Subheading 3.2 above) onto the gradient, completely fill the tubes.

3.4 *Ultra centrifugation*

3.4.1 *Rate Zonal Centrifugation*

Modern ultracentrifuges, such as the Beckman Optima™ L-100 XP (Beckman Coulter), have rate zonal run simulation programs built into the centrifuge. By inserting the S-value (sedimentation coefficient) of the VLP (or native virion) to be purified, the machine will calculate the time needed to centrifuge the sample in a specific rotor to separate VLPs according to their sedimentation coefficient, without pelleting the VLPs (<https://www.beckmancoulter.com/wsportal/bibliography?docname=A-1941B.pdf>).

The centrifugation time for rate zonal purification is normally shorter than the time required for isopycnic centrifugation. If a pellet is present after a run, this may indicate that the centrifugation time was too long and has to be decreased (*see Note 21*).

Example: If you have a particle with a sedimentation coefficient of 500 S, centrifugation on a 10–40 % sucrose gradient at 20 °C for 90 min will result in the VLPs sedimenting to the 30–35 % fractions (approximately 3–4 mL from the bottom of the tube).

3.4.2 *Isopycnic Centrifugation*

The time and speed of centrifugation will depend on the density of the VLP to be purified. As long as the density of the VLPs to be purified does not exceed that of the highest density of the gradient—this will ensure that the VLPs do not pellet even after longer centrifugation times. It is advisable to research the parameters used to purify the native virion (or that of a similar virus) and to use that as a starting point for purification.

Normally 2–5 h centrifugation time at 150,000–170,000 × *g* is sufficient for isopycnic separation on a pre-formed gradient. Figure 2 depicts gradients after ultracentrifugation of either the clarified crude extract or the dialyzed 20 % sucrose sample.

3.5 *Harvesting Gradients*

1. Carefully remove the centrifuge tubes from the rotor buckets, this sometimes requires tweezers.

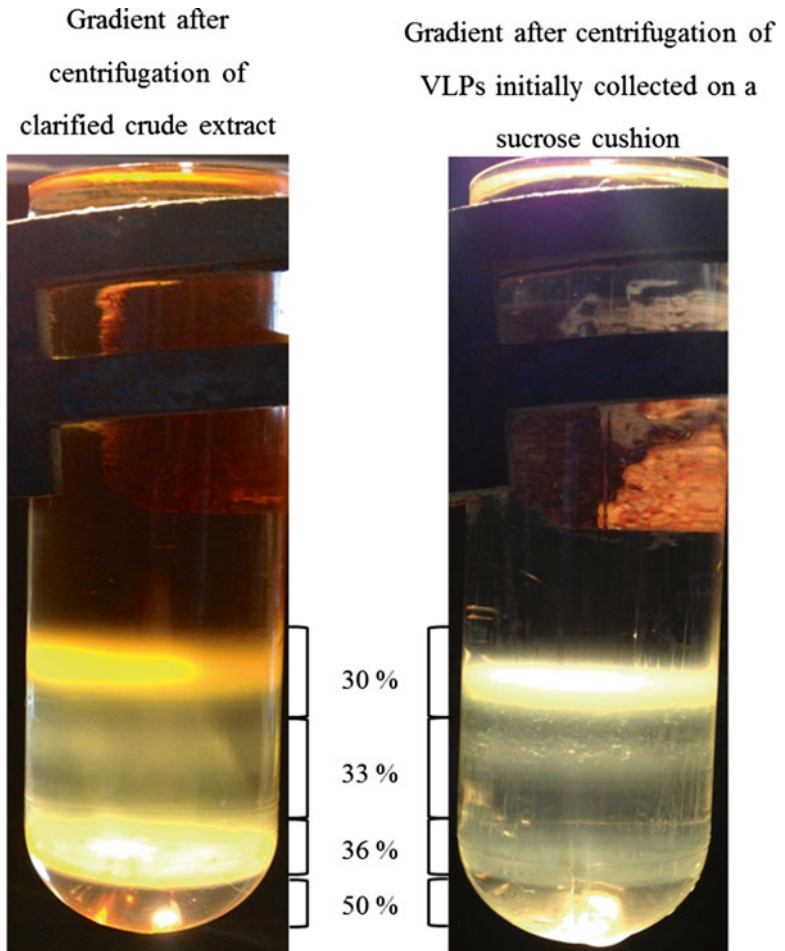

Fig. 2 Gradient images showing the differences after isopycnic centrifugation of clarified crude plant extract (*left*) compared to VLPs initially pre-purified on a 20 % sucrose cushion (*right*)

2. If an automated fractionator is available, follow the user manual instructions and collect the required fraction volumes (normally 500 μL –2 mL) from the bottom of the tube (highest density) upwards (lowest density). Fractions can be collected in microcentrifuge tubes.
3. For fractionation by hand:
 - (a) Carefully clamp the centrifuge tube in a retort stand, make sure the tube is stable.
 - (b) Gently “drill” a hole in the bottom of the tube with a 21 gauge needle (*see Note 22*).
 - (c) Remove the needle—the sample will start dripping out of the hole that was just created.

- (d) Collect the fractions in microcentrifuge tubes. The less dense the sample is, the faster it will drip.
4. Fractionate the entire volume of the centrifuge tubes.
5. Store fractions at 4 °C. Freezing of VLPs may disrupt their structure.
6. Analyze the fractions with SDS-Page/Western blotting and TEM to determine where in the gradient the VLPs are localized.

4 Notes

1. OptiPrep™ is a solution of 60 % iodixanol in water that is sterile and endotoxin-tested. The solution has a density of 1.32 g/mL.
2. For higher concentration sucrose solutions (greater than 40 %), heating may be required to ensure that the sucrose dissolves completely. Ensure that the solutions are at room temperature before pouring the cushion/gradient or centrifugation.
3. Make OptiPrep™ solutions just prior to pouring gradients. Use the equation $C_1 V_1 = C_2 V_2$ to calculate the volumes needed to make the solutions.
4. Refer to the applicable rotor manual and ensure that the rotors and components are designed for use in the relevant ultracentrifuge (for useful guidelines refer to: <https://www.beckman-coulter.com/wsrportal/techdocs?docname=LR-IM-24>). Maximum rotor speed is engraved on the rotor and this should not be exceeded. Speed reductions are required when a solution is centrifuged that has a density greater than the density rating of the rotor (see relevant rotor manual). The maximum run speed can be determined by using the following formula:

$$\text{reduced run speed} = \text{maximum rate speed} \frac{\sqrt{A}}{B}$$

where A = rotor density rating, B = actual density of the contents being centrifuged.

5. Swinging-bucket rotors are used for pelleting, isopycnic separation (particles separated on the basis of their buoyant density) and rate zonal centrifugation (separation of particles is based on their sedimentation coefficient—density, size and shape).
6. Example: if 10 g leaf material is processed, 3 volumes of extraction buffer will constitute 30 mL. If protease inhibitors are to be used, they should be added at this step.
7. Thoroughly homogenize until a mostly homogenous crude extract is obtained.

8. If the aim is to concentrate the VLPs into the 20 % sucrose cushion add 1 mL 50 % sucrose step under the 20 % sucrose cushion. This should keep the VLPs in the 20 % sucrose and prevent them from pelleting. By centrifuging through a cushion, many of the contaminating plant proteins will be removed from the protein preparation.
9. A syringe can also be used for this purpose.
10. Tubes can be topped up with the purification buffer if the volume of clarified crude plant extract is not enough.
11. To balance the rotor all opposing tubes must be filled to the same level with solutions/liquids of the same density. Tubes are balanced by weight and not volume. In our laboratory we prefer to balance tubes to within 0.01 g.
12. To calculate the time needed for VLPs to pellet at a certain speed, you need to know the buoyant density of the particular VLP.

Use the following formula: $T = \frac{k}{S}$, where

T = time taken to pellet a given particle

k = k factor, clearing factor at a given speed taking into account velocity and rotor dimensions (different rotors will have different k factor values).

S = sedimentation coefficient, the value assigned to a particle describing its migration through a medium. Measured in Svedberg units.

Example: Particle X has a sedimentation coefficient of 300 S

The Beckman SW32 Ti rotor has a k factor of 204 at maximum speed of $174,587 \times g$.

$$\text{If: } T = \frac{k}{S},$$

$$\text{Then: } T = \frac{204}{300}$$

$$T = 0.68$$

Therefore, particle X must be centrifuged for 0.68 h (~40 min) at maximum speed in a SW32 Ti rotor to be pelleted.

13. The centrifugation time can be calculated the same way as in **Note 12** above, however ensure that a more dense sucrose step (i.e., 50 % sucrose) is underneath the 20 % sucrose cushion to prevent VLPs from pelleting. If the sedimentation coefficient of the VLP is not known, centrifugation for 1–1.5 h at maximum speed should be more than sufficient for collection of VLPs in the 20 % sucrose cushion.
14. Rinse rotor buckets with mild rotor detergent if any liquid spilled out and dry completely.

15. Sometimes a dark green band is not visible between the 50 % and 20 % sucrose interface—this can be dependent on the extraction buffer used. Make a mark on the tube at the interface prior to centrifugation, this can then be used as a guide to determine where the 20 % sucrose cushion starts (after centrifugation) and where to insert the needle to remove the cushion.
16. The sucrose has to be removed from the sample to prevent the dense solution from “sinking” into the continuous/discontinuous gradients.
17. OptiPrep™ can be used instead of sucrose.
18. Since the continuous gradient is formed by a physical process, control of the time and temperature is important. By establishing these variables, the shape of the gradient is reproducible.
19. Continuous gradients can also be used for isopycnic centrifugation, as long as the highest density of the gradient exceeds that of the VLP to be purified.
20. AXIS-SHIELD (<http://www.axis-shield-density-gradient-media.com/virusindexes.htm>) have methods available for the purification of various viruses—these may provide useful guidelines as a starting point for purification of your VLP of interest. Also refer to literature, methods used for purification of the virus or VLPs of interest from cell culture will also provide useful information for a starting point. From here on the purification process can be optimized for purification from plants.
21. If a pellet is present after rate zonal centrifugation, analyze with SDS-Page/Western blotting. If it contains the protein of interest, the centrifugation time must be shortened. If not, it possibly means structures with sedimentation coefficients higher than that of the VLP to be purified was present in the sample, and these pelleted during centrifugation. In this case there is no need to adjust the centrifugation time.
22. At this point make sure the required amount of microcentrifuge tubes are ready to start collecting fractions as soon as the needle is removed from the centrifuge tube.

5 Useful Links

1. <https://www.beckmancoulter.com/wsrportal/techdocs?docname=LR-IM-24>
2. <http://www.sigmaaldrich.com/technical-documents/articles/biofiles/centrifugation-separations.html>
3. <http://www.axis-shield-density-gradient-media.com/virusindexes.htm>
4. <https://www.beckmancoulter.com/wsrportal/bibliography?docname=A-1941B.pdf>

Acknowledgements

We would like to thank Ed Rybicki, Ann Meyers, and everyone in the Biopharming Research Unit at University of Cape Town for their contribution to the development of the techniques. We acknowledge the National Research Foundation, Department of Science and Technology, the Poliomyelitis Research Foundation, the Medical Research Council, the University of Cape Town Research Committee, the Cancer Research Foundation of South Africa, the PlaProVa project of the EU FP7 initiative, and Era Biotech for funding.

References

1. Roldao A, Mellado MCM, Castilho LR, Carrondo MJT, Alves PM (2010) Virus-like particles in vaccine development. *Expert Rev Vaccines* 9:1149–1176
2. Rybicki EP (2014) Plant-based vaccines against viruses. *Virology* 461:205
3. Scotti N, Rybicki EP (2013) Virus-like particles produced in plants as potential vaccines. *Expert Rev Vaccines* 12:211–224
4. Herbst-Kralovetz M, Mason HS, Chen Q (2010) Norwalk virus-like particles as vaccines. *Expert Rev Vaccines* 9:299–307
5. Sharpe PT (1988) *Methods of cell separation*. Elsevier Science, Amsterdam

Transient Expression of Viral Proteins in Plants Using *Agrobacterium tumefaciens*

Inga I. Hitzeroth and Albertha R. van Zyl

1 Introduction

Expression of viral proteins in plants is an attractive alternative to existing expression platforms such as cell culture, yeast, *E. coli*, or eggs [1]. Viral proteins are often utilized as potential vaccines or in diagnostics. There are many advantages to express viral vaccines in plants such as the cost of vaccine production, no contamination with mammalian products, ability to glycosylate proteins, and the speed of production. Initially viral proteins were expressed in transgenic plants which took many months, but more recently transient expression of proteins utilizing infiltration with recombinant *Agrobacterium tumefaciens* has been used widely [2, 3]. One of the most important considerations before one starts this work is the choice of plant expression vectors. Various viral vectors such as magnICON[®] from ICON Genetics (<http://www.icongenetics.com/html/02.htm>) which are also delivered by agrobacterial T-DNA transfer are available. Most often RNA viruses such as *Tobacco mosaic virus* (TMV), *Potato virus X* (PVX), and *Compea mosaic virus* (CPMV) are used [4, 5]. There are vectors that use the DNA viruses such as the geminivirus bean yellow dwarf virus as a backbone, resulting in a replicating vector which also increases protein expression [6]. Another factor to consider is targeting of the protein to various plant cell compartments as that can have profound effect on protein expression levels, and a set of vectors targeting the proteins to the cytoplasm, chloroplast, ER, or apoplast are described in Maclean et al. (2007) [7]. Finally, codon usage of the gene of interest is an important factor that can have an effect on protein expression, and this needs to be determined for each gene empirically, but in general changing the codon usage

to one preferred by *Nicotiana benthamiana* and thereby increasing the GC content to above 50 % tend to enhance protein expression. Each plant expression vector in turn needs a specific *Agrobacterium* strain, the choice of which depends on Ti vector resident in the *Agrobacterium* strain [8].

Transient expression of viral proteins in plants utilizing infiltration with recombinant *Agrobacterium* results in protein expression within 2–7 days. It is a fully scalable process as has been demonstrated by companies such as Medicago (<http://www.medicago.com>). Plants often respond to viral infections by suppressing viral gene expression by posttranscriptional gene silencing (PTGS). Silencing suppressors are made in turn by plant viruses in response to the plant defense. NSs from *Tomato spotted wilt virus* (TSWV) is such a RNA silencing suppressor protein which inhibits the onset of PTGS [9]. By co-expressing a silencing suppressor with the protein of choice, protein expression can very often be enhanced. Protein expression levels in crude leaf extracts can be determined by polyacrylamide gel electrophoresis (PAGE) or Western blots.

Preparation of electrocompetent *Agrobacterium*, transformation of *Agrobacterium*, infiltration of tobacco plants, expression of viral protein, and extraction of the protein for gel electrophoretic analysis are described in this chapter.

2 Materials

2.1 Media and Solutions

All media and solutions should be prepared with distilled water at room temperature. All media and solutions must be autoclaved at 121 °C for 20 min. Be sure to wear the relevant personal protective equipment (PPE) and to adhere to disposal regulations when disposing of waste material and sharps.

1. 0.05 % gibberellic acid: Dissolve 0.05 g gibberellic acid in 95 mL water and top up to 100 mL water. Autoclave and store at 4 °C.
2. Peat/vermiculite soil mixture: Mix together 120 L peat, 10 kg vermiculite, 85 mL 2:3:2 fertilizer, and 85 mL dolomitic lime.
3. Sterile water.
4. 10 % glycerol: Add 100 mL glycerol to 900 mL distilled water, mix thoroughly, and autoclave. Store at room temperature.
5. 50 % glycerol: Add 500 mL glycerol to 500 mL distilled water, mix thoroughly, and autoclave. Store at room temperature.
6. LB broth, pH 7.4: Add 800 mL distilled water to a glass beaker. Weigh out 10 g tryptone, 5 g yeast extract, and 5 g NaCl and transfer to the glass beaker. Mix until the powders have dissolved completely. Adjust the pH to 7.4 with NaOH

and add water to a final volume of 1 L. Make 5, 10, and/or 100 mL aliquots of the LB media and autoclave. Store at room temperature.

7. LB media plates: Make media as in number 4 above, but add 7.5 g agar prior to adjusting the pH. Adjust pH to 7.4 using NaOH and fill up to 1 L with distilled water. Autoclave the media. After autoclaving, cool the media to ~50 °C. At this point, the relevant antibiotics can be added using sterile techniques. Mix well by swirling and pour plates. Fill each petri dish ½ full; make sure there are no air bubbles (*see Note 1*). Let plates cool at room temperature overnight and place them upside down back into their plastic sleeves. Seal the bag and label properly with the date and antibiotic content. Plates can be stored for 1 month at 4 °C.
8. Induction medium, pH 5.6: Follow the LB broth recipe above and also add 1.952 g MES (final concentration: 10 mM; *see Note 2*). Adjust pH to 5.6 with HCl and add distilled water to a final volume of 1 L. Aliquot either 50, 100, or 500 mL into Erlenmeyer flasks and autoclave (*see Note 3*). Store at room temperature.
9. 1 M magnesium sulfate stock: Add 12 g MgSO₄ to 80 mL distilled water, mix thoroughly, and adjust to a final volume of 100 mL. Sterilize by autoclaving and store at room temperature.
10. Infiltration medium, pH 5.6: To 500 mL distilled water in a beaker, add 30 g sucrose, 2.03 g MgCl₂, and 1.952 g MES. When completely dissolved, adjust the pH to 5.6 and autoclave. Store at room temperature (*see Note 4*).
11. 200 mM acetosyringone stock solution: Dissolve 0.3924 g acetosyringone in 10 mL DMSO (*see Note 5*). Filter sterilize using 0.22 µm syringe filters and make 1 mL aliquots in microcentrifuge tubes. Store at -20 °C.
12. 70 % ethanol: Add 700 mL technical grade ethanol to 300 mL distilled water and mix. Put in a spray bottle to use for disinfecting surfaces.

2.2 Antibiotics

The antibiotics used will depend on what antibiotic resistance genes are present on the plant expression vector to be used. Antibiotic stocks are mostly made with distilled water; these cannot be autoclaved but must be filtered through a 0.22 µm syringe filter, after which aliquots can be stored at -20 °C. Antibiotics are thawed prior to adding to the media.

1. 20 mg/mL rifampicin stock solution: Add 0.02 g rifampicin powder to 8 mL methanol in a conical tube and adjust volume to 10 mL with methanol. Vortex thoroughly to dissolve the rifampicin. Do not filter sterilize. Make 1 mL aliquots and store at -20 °C (*see Note 6*).

2.3 Plants

Cover 0.1 g *Nicotiana benthamiana* seeds (*see Note 7*) with 0.05 % gibberellic acid in a microcentrifuge tube and leave at room temperature overnight. Dry the seeds on Whatman filter paper and sow in potting soil that has been thoroughly watered and treated with fertilizer (*see Note 8*). Let the seeds germinate in the dark for 3 days after which they should be grown at 22 °C under 16 h/8 h light/dark cycles. Water plants every second day and fertilize once a week (*see Note 9*). After 2 weeks, transplant seedlings into their own pots containing the peat/vermiculite soil mixture (*see Note 10*). When plants are 4–6 weeks old, they are ready to be infiltrated.

2.4 Equipment Required

1. PPE.
2. –70 °C freezer.
3. Shaking incubator set at 27 °C.
4. Centrifuge (Beckman).
5. JA17 rotor (Beckman).
6. Sterile SS34 centrifuge tubes.
7. Gene Pulser™ (Bio-Rad).
8. 0.1 cm electroporation cuvettes (Invitrogen™).
9. Microcentrifuge tubes.
10. PCR tubes.
11. PCR machine.
12. Inoculation loop.
13. Spectrophotometer.
14. Cuvettes.
15. 1 mL syringes—for small-scale infiltration.
16. Vacuum chamber and vacuum pump—advised for large-scale infiltration.
17. 1 L beaker.
18. Liquid nitrogen.
19. Benchtop microcentrifuge.
20. Micropestles (for small-scale protein extraction).
21. Ceramic mortar and pestle (for large-scale protein extraction).
22. Miracloth (Merck).

3 Methods

3.1 Electrocompetent *Agrobacterium* (See Note 11)

1. Add 25 µL of the 20 mg/mL rifampicin stock (*see Note 12*) solution to 10 mL LB media (*see Note 13*).
2. Inoculate the media with 1 mL –70 °C glycerol stock of the *Agrobacterium* strain to be used and incubate 16–18 h overnight at 27 °C with agitation.

3. Add 250 μL rifampicin (and whichever other antibiotics are required for helper plasmids) to 100 mL LB media and inoculate with the entire 10 mL overnight culture. Incubate 16–18 h overnight at 27 °C with agitation.
4. Fill two SS34 centrifuge tubes with the 100 mL overnight culture and centrifuge at $2200\times g$ for 10 min at 4 °C in order to pellet the cells.
5. Decant the supernatant and resuspend the cell pellets in 2 mL (*see Note 14*) sterile water. Fill up tubes with sterile water and centrifuge at $2200\times g$ for 10 min at 4 °C.
6. Repeat the water rinse step again and centrifuge as above.
7. Decant the supernatant and resuspend the cell pellets in 2 mL 10 % glycerol and wash twice as described in **steps 5 and 6** above.
8. Resuspend each of the pellets in 2.5 mL 10 % glycerol and combine the contents of the two tubes.
9. Make 500 μL aliquots in microcentrifuge tubes and store at -70 °C for transformations.

3.2 Transformation of *Agrobacterium* by Electroporation

1. Thaw an aliquot of electrocompetent *Agrobacterium* cells (made in Subheading 3.1 above) on ice.
2. Pipette 100 μL thawed cells into chilled 0.1 cm gap electroporation cuvettes (*see Note 15*).
3. Add 200 ng recombinant plasmid DNA (*see Note 16*) to the cells and gently pipette up and down to mix with the cells.
4. Incubate on ice for 5 min and electroporate (*see Note 17*) under the following conditions using a Gene Pulser™ (Bio-Rad): 1.8 kV, 25 μF , 200 Ω .
5. Place the cuvettes back on ice after electroporation and add 900 μL LB media to the cuvette. Pipette the cells out into a sterile microcentrifuge tube and incubate for 2 h at 27 °C.
6. During the 2 h incubation period also warm LB media plates supplemented with the relevant antibiotics to 27 °C. Keep the plate upside down to prevent condensation droplets from forming on the surface of the media.
7. Plate out 100 μL of electroporated *Agrobacterium* cells on the LB media plates supplemented with the relevant antibiotics (*see Note 18*).
8. Incubate plates upside down at 27 °C for 2–3 days.

3.3 Verification of Recombinant *Agrobacterium* by Colony PCR

1. Screen 5–20 of the colonies that are present on the LB plates (*see Note 19*).
2. Make a masterplate of the colonies that are screened (*see Note 20*).

3. Colony PCR: Use 2–5 μL of the resuspended *Agrobacterium* colony (*see Note 20*) as template DNA in the same PCR reaction that was used for initial amplification of the gene(s) of interest. Colonies displaying the DNA fragments at the correct size on an agarose gel are positive (*see Note 21*). Mark the positive clones on the masterplate.
4. After the recombinant *Agrobacterium* has grown on the masterplate, scrape off some of the culture (positive clone) with an inoculation loop and do a three-way streak for single colonies on LB media plates containing the relevant antibiotics. Incubate at 27 °C for 2–3 days until single colonies appear.
5. Inoculate a single recombinant *Agrobacterium* colony in 10 mL LB media supplemented with the relevant antibiotics and incubate overnight at 27 °C with agitation.
6. Make 1 mL aliquots of the liquid culture and add 1 mL sterile 50 % glycerol to yield a final concentration of 25 % glycerol.
7. Store the cultures at –70 °C for future infiltrations.

3.4 Preparation of *Agrobacterium* Cultures for Infiltration

1. Thaw a glycerol stock of the recombinant *Agrobacterium* and inoculate it into 5 mL LB media supplemented with the relevant antibiotics. Incubate overnight at 27 °C with agitation to revive the culture.
2. Inoculate 5 mL of the overnight culture into 50 mL induction medium supplemented with the relevant antibiotics. If this 50 mL culture is to be used for infiltration, 5 μL of the 200 mM acetosyringone stock should be added to the culture (yielding a final concentration of 20 μM , *see Note 22*). Incubate overnight at 27 °C with agitation.
3. At this point, the recombinant *Agrobacterium* culture can be used for small-scale infiltration, or the 50 mL culture can be inoculated into 500 mL induction medium to scale up the culture volume for infiltration.
4. Centrifuge the cultures at $2200\times g$ for 10 min at 4 °C to pellet the cells. Decant the supernatant after centrifugation.
5. Add 1 mL of 200 mM acetosyringone stock (final concentration 0.2 mM) to 1 L of infiltration medium.
6. Resuspend the cell pellet obtained in **step 4** above in 5 mL infiltration medium supplemented with acetosyringone.
7. Incubate the resuspended cells at room temperature for 1–2 h to allow for the acetosyringone to induce the *vir* genes.
8. Determine the OD_{600} (*see Note 23*) of the resuspended cells and dilute (*see Note 24*) in infiltration medium to the required OD for infiltration (*see Note 25*).
9. Sometimes co-infiltration with a silencing suppressor (*see Note 26*) is required, or the co-expression of more than one protein is required (*see Notes 27 and 28*).

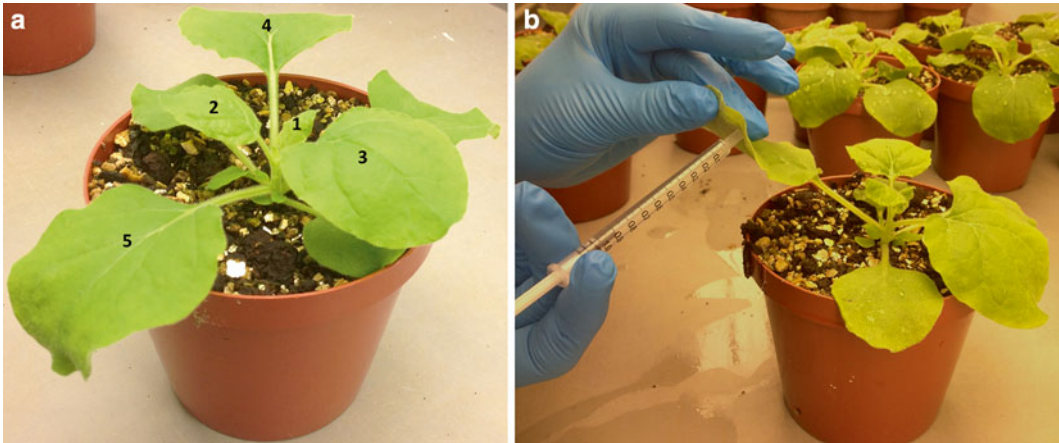

Fig. 1 (a) *Nicotiana benthamiana* leaves 3, 4, and 5 are best for agroinfiltration. (b) Syringe infiltration of leaves. The leaf is held in place with the middle finger and thumb. The open end of the syringe is placed against the bottom of the leaf, and gentle pressure is applied with the middle finger while pressing down on the syringe

3.5 Infiltration

3.5.1 Syringe Infiltration: Small Scale

1. Fill a 1 mL syringe with the *Agrobacterium* suspension solution.
2. Hold a leaf of a 4–6-week-old *N. benthamiana* plant gently with your pointer and middle fingers on the topside of the leaf and your thumb on the lower leaf surface (see **Note 29**, Fig. 1a, b).
3. Hold the filled 1 mL syringe in your other hand and gently press the opening of the syringe against the underside of the leaf against your middle finger.
4. Push down the syringe plunger and gently apply pressure with your middle finger on the topside of the leaf; as you push down on the plunger, the *Agrobacterium* suspension should enter the abaxial air spaces of the leaves (see **Note 30**). The leaves that have been successfully infiltrated will appear translucent (Fig. 2).
5. Infiltrate the leaf in sections until the whole leaf area appears translucent.
6. After infiltration, make sure that infiltrated leaves don't touch each other and spray the leaves with 70 % ethanol to disinfect the surfaces and to avoid the growth of fungi.

3.5.2 Vacuum Infiltration: Large Scale

1. For the infiltration of many plants, it is advisable to use vacuum infiltration (see **Note 31**, Fig. 3).
2. Fill a 1 L beaker to the brim with the resuspended *Agrobacterium* solution (see **Note 32**).
3. Cover the surface of the pot containing the plant to be infiltrated with aluminum foil, gently wrap the foil around the base of the plant stem, or cover with a perspex/plastic cover (see **Note 33**, Fig. 4a, b).

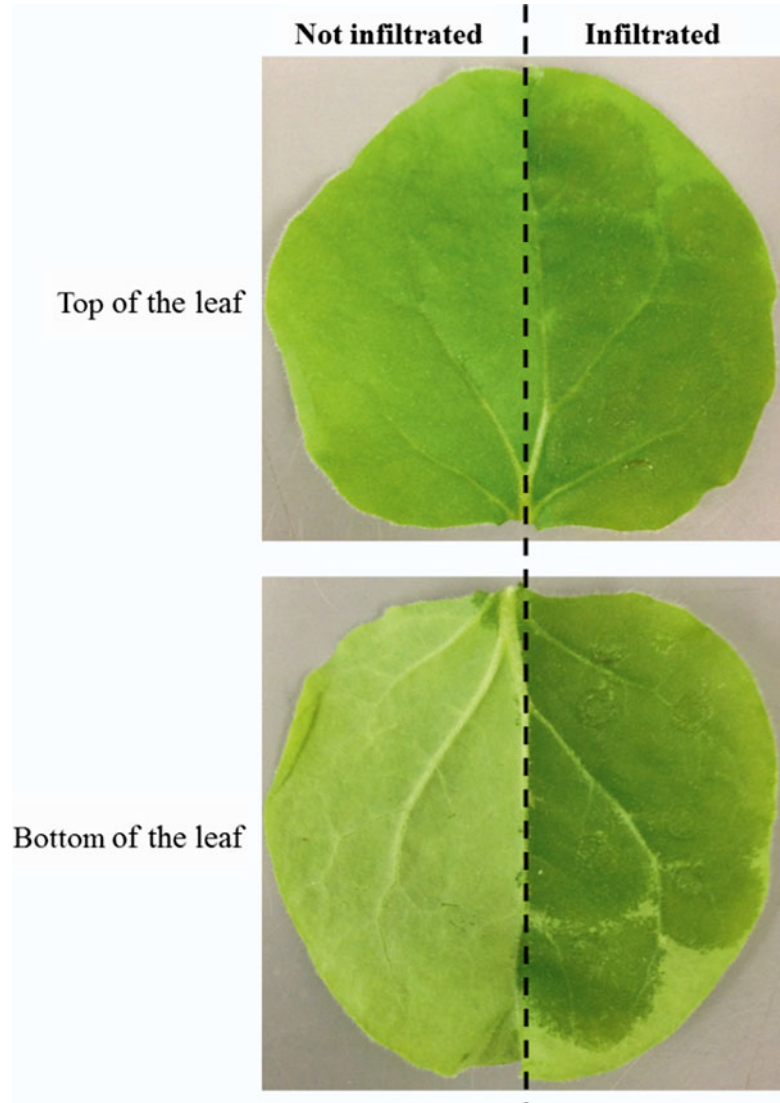

Fig. 2 Image of a leaf showing the difference between infiltrated and non-infiltrated areas

4. Turn the plant upside down and submerge the entire plant in the *Agrobacterium* solution within the 1 L beaker—rest the sides of the pot on the beaker.
5. Seal the vacuum chamber and maintain a vacuum of -90 kilopascal (kPa) for 5 s and rapidly release ($10\text{--}15$ kPa.sec $^{-1}$) the vacuum (*see Note 34*). Repeat this process two more times to ensure efficient infiltration of the entire plant.
6. Remove any leaves that were not infiltrated and also remove the aluminum foil/perspex cover from the pot.
7. Spray plants with 70 % ethanol.

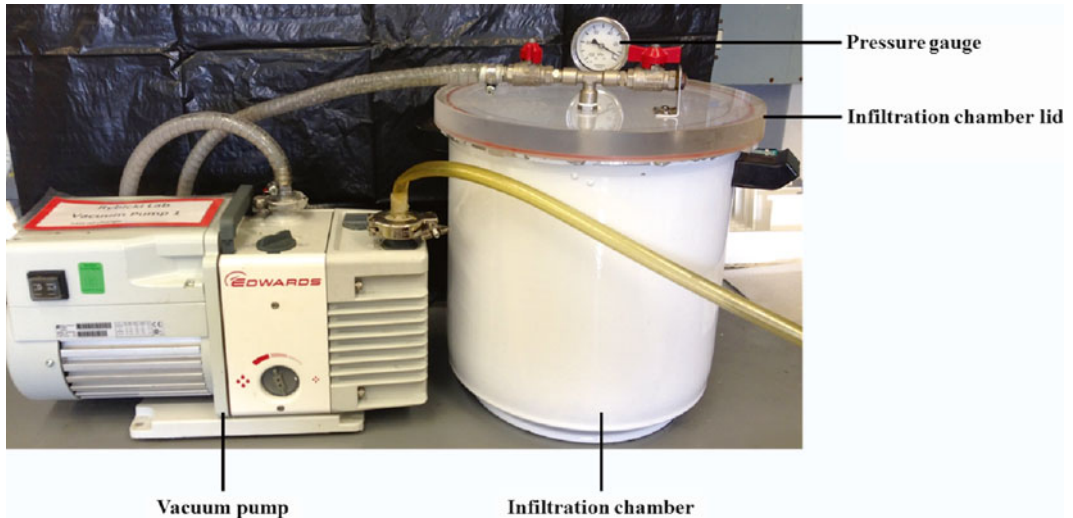

Fig. 3 Vacuum infiltration equipment used for large-scale vacuum infiltration of plants

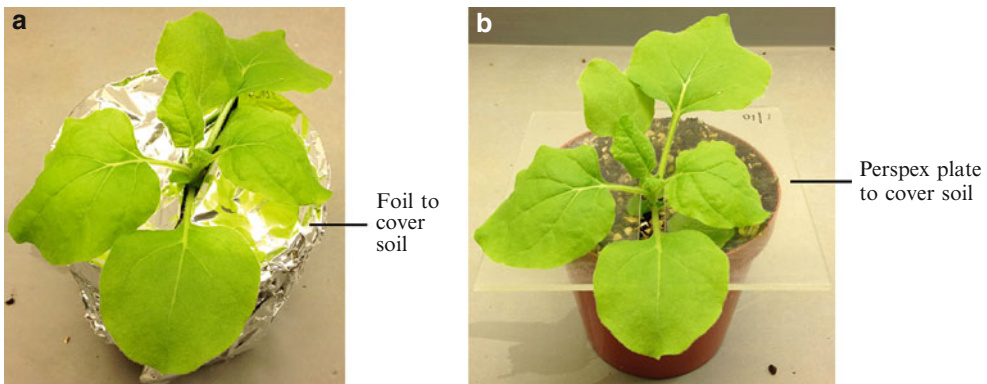

Fig. 4 (a) Pot covered with aluminum foil to prevent soil from falling out during vacuum infiltration. (b) Pot covered with a Perspex coverslip. The coverslip has a slit down the middle where the main stem of the plant and the leaves go through

For both syringe- and vacuum-infiltrated plants, continue to grow and water as normal. Protein expression can be monitored from 2 to 10 days post infiltration (dpi).

3.6 Harvesting of Leaves

1. For time trials, harvest three leaf disks from different leaves by using the cap of a microcentrifuge tube (*see Note 35, Fig. 5*).
2. Flash-freeze microcentrifuge tubes containing the leaf disks in liquid nitrogen and store at -70°C .
3. For large scale, harvest whole leaves at the required day post infiltration and measure the fresh weight of the leaves. Seal leaves in a plastic bag, flash-freeze in liquid nitrogen, and store at -70°C .

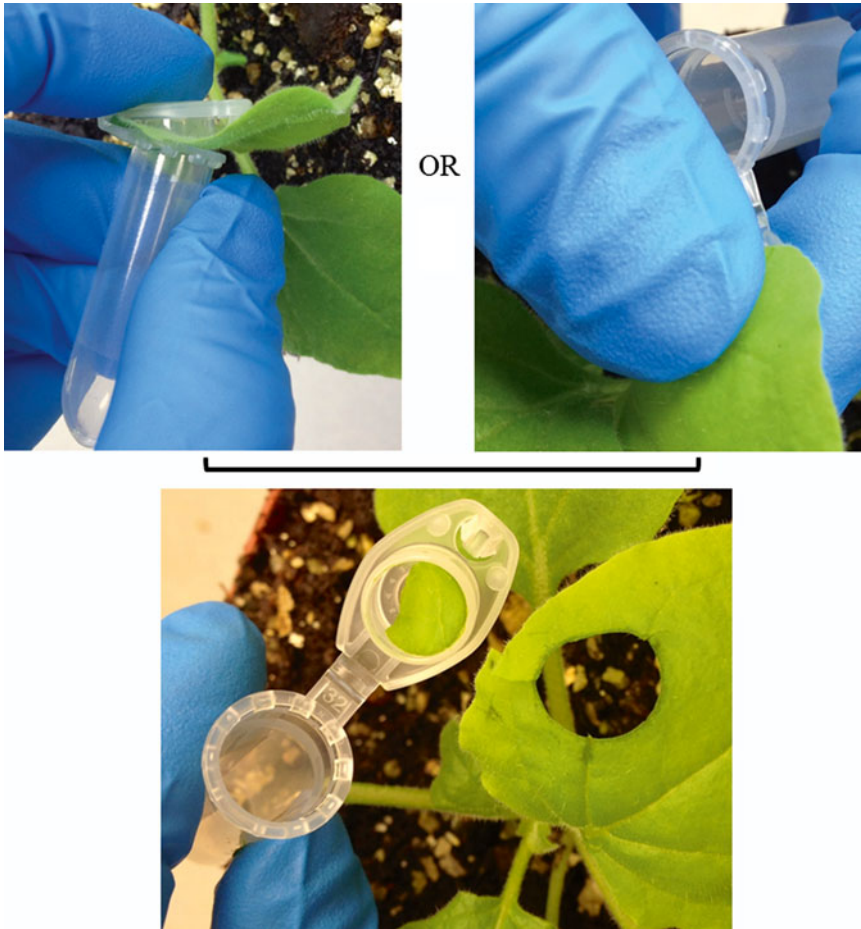

Fig. 5 Harvesting leaf disks with a microcentrifuge tube

3.7 Protein Extraction and Analysis

3.7.1 Protein Extraction from Leaf Disks

1. Grind leaf disks in the microcentrifuge tube they were frozen in, in the presence of liquid nitrogen, with a micropestle (*see Note 36*).
2. Grind leaf material until a fine powder forms.
3. Add 300 μL of the relevant extraction buffer (*see Note 37*) and gently vortex the suspension.
4. Incubate on ice for at least 1 h to enhance extraction of the protein of interest.
5. Clarify the crude extract by centrifuging at $15,000\times g$ for 10 min in a benchtop microcentrifuge.
6. Aspirate the supernatant and analyze the crude extract with SDS-PAGE and Western blot analysis.

3.7.2 Large-Scale Protein Extraction

1. Place leaf material in a ceramic mortar and cover with liquid nitrogen (*see* **Note 38**) and grind leaves into a fine powder with a pestle.
2. Place the fine leaves in a sealable container and add three volumes of the relevant buffer to the leaf material (*see* **Note 39**).
3. Incubate crude plant extract at 4 °C for at least 1 h with gentle agitation to facilitate protein extraction.
4. Filter the crude extract through two layers of Miracloth and discard the solid material remaining on the Miracloth.
5. Clarify the filtrate by centrifuging for 10 min at 15,000×g, 4 °C.
6. Decant the supernatant and centrifuge again as in **step 5** above.
7. Analyze the clarified crude extract with SDS-PAGE and Western blot analysis.

4 Notes

1. Flame air bubbles with the Bunsen burner to pop them.
2. 2-Morpholinoethanesulfonic acid salt, molecular weight: 195.2 g/mol.
3. The volume of induction medium will depend on the scale of infiltration. For small-scale infiltration (5 plants), 50 mL induction medium should suffice. For larger-scale infiltration (10–20 plants), at least 500 mL induction medium should be used. In both cases, the amount of induction media needed could be more or less dependent on the OD of the bacterial suspension used for infiltration. For shaking cultures, use 10 % working volume; for example, a 50 mL culture will be grown in a 500 mL Erlenmeyer flask, 100 mL culture in a 1 L Erlenmeyer flask, 500 mL culture in a 5 L Erlenmeyer flask and so on. This will ensure proper aeration and growth of the cultures.
4. If the infiltration medium is made in advance, it can be autoclaved; however, if it's made just prior to infiltration, there is no need to autoclave the medium and it can be used as is.
5. Acetosyringone = 4'-hydroxy-3',5'-dimethoxyacetophenone. DMSO = dimethyl sulfoxide. Acetosyringone will not dissolve in water; therefore, it must be prepared in DMSO.
6. Rifampicin will not dissolve in water; therefore, it must be made in methanol. Methanol is highly toxic and all work done with methanol should be carried out in a fume hood with PPE.
7. 0.1 g seeds are enough to seed two 25 cm × 15 cm seeding trays.
8. Margaret Roberts Organic Supercharger (Kirchhoff) works well for fertilizing seeds.
9. Chemicult hydroponic nutrient powder (made according to instructions) is used for this.

10. Seedlings should have at least four leaves when they are transplanted to the bigger pots. Make sure not to damage the roots. Plant the seedlings deep enough to avoid them falling over when they are watered.
11. All inoculation steps should be carried out using sterile techniques.
12. For a final concentration of 50 µg/mL rifampicin, do not flame the rifampicin aliquot when opened—methanol is highly flammable. Only flame the test tube containing the LB media prior to and after addition of the rifampicin.
13. The antibiotics added at this point will be influenced by the type of *Agrobacterium* used. For example, LBA4404 contains no helper plasmid; therefore, the only antibiotic to be added to the media will be rifampicin (which selects for *Agrobacterium*). However, this strain is prone to clumping in liquid media; therefore, 20 µL 1 M MgSO₄ (2 mM final concentration) must be added to the media to prevent clumping. On the other hand, GV3101::pMP90RK contains a kanamycin-resistant helper plasmid; therefore, 3 µL of a 100 mg/mL kanamycin stock solution (30 µg/mL final concentration) should also be added to the media. This strain does not clump; therefore, no MgSO₄ has to be added to the media.
14. It is easier for the cell pellet to be resuspended in a smaller volume before filling the centrifuge tubes.
15. Do not touch the metal sides of the electroporation cuvettes. Sometimes this causes a short circuit when the cells are electroporated, resulting in a spark and a loud popping sound. Electroporation cuvettes can be reused if absolutely necessary. Make sure to wash thoroughly with water and 70 % ethanol and afterward let the cuvettes dry completely.
16. The concentration of recombinant DNA used for electroporation can be increased or decreased in order to further optimize this step. A concentration of 40–400 µg recombinant DNA can be used for electroporation. Use circular vector DNA as a positive control and linearized vector DNA as negative control.
17. Thoroughly dry the cuvettes with tissue paper before electroporation.
18. Normally, the concentration of electrocompetent cells produced is quite high; therefore, only 100 µL of the electroporated *Agrobacterium* suspension can be plated out. If the cell concentration is suspected to be low (due to suboptimal growth conditions during preparation of the electrocompetent cells), it is advisable to concentrate the electroporated cells by centrifuging at 1500×g in a benchtop centrifuge. Decant the supernatant and gently resuspend the cell pellet in 100 µL LB media prior to plating out.

19. The transformation efficiency of *Agrobacterium* using electroporation is quite high; therefore, only a few (2–4) colonies need to be screened to start off with. More colonies can be screened should it be required.
20. The masterplate will contain the same antibiotics as the plates used to grow the recombinant *Agrobacterium*. Label the masterplate with the date and the name of the construct screened. Draw 1 cm × 1 cm blocks on the bottom of the plate and label the blocks 1—however, many colonies are to be screened. Pick up colonies from the plate with a pipette tip and suspend the colony in 15 μL sterile water. Drop 2.5 μL of the resuspended colony in the relevant block on the masterplate; do this for all the colonies to be screened. Let the masterplate dry completely before incubating 2–3 days at 27 °C.
21. Remember to include positive and negative controls for PCR screening.
22. Acetosyringone is added to the culture in order to induce the *vir* genes.
23. Make a 1:4 dilution of the resuspended cells in infiltration medium (250 μL cells + 750 μL infiltration medium) and measure OD₆₀₀. Multiply the OD₆₀₀ measured with the dilution factor (4) to obtain the OD₆₀₀ of the resuspended *Agrobacterium* cells.
24. Use the equation $C_1 V_1 = C_2 V_2$ to determine the volume of resuspended *Agrobacterium* cells that must be diluted with infiltration medium to obtain a certain cell concentration (final OD₆₀₀) for infiltration.
 C_1 = OD₆₀₀ of the resuspended cells (i.e., concentration),
 V_1 = volume of resuspended *Agrobacterium* cells needed,
 C_2 = OD₆₀₀ required for infiltration, and V_2 = final volume.
Thus, the volume of infiltration medium needed = $V_2 - V_1$.
Always check the final OD₆₀₀ after combining the culture and the infiltration medium.

The values obtained here will also give a good indication of how much culture must be grown for future studies and how the culture volumes can be adjusted to facilitate infiltration of more or less plants.
25. A range of infiltration ODs should be tested to find the OD at which the protein of interest is optimally expressed. Normally, OD₆₀₀ = 0.5 is a good starting point; from here on either higher (1.0) or lower (0.25) ODs can also be investigated. It is possible that higher ODs may result in necrosis of plants, but this is also dependent on the protein that is expressed.
26. *Agrobacterium*-mediated transient expression of recombinant proteins can be enhanced by co-infiltrating plants with recombinant *A. tumefaciens* that encode silencing suppressor genes, which “silences” RNA-mediated gene silencing.

27. Before co-expression of more than one construct, it is important to ascertain that expression of the proteins of interest can be achieved when they are expressed on their own (or in the presence of the silencing suppressor).
28. When more than one construct are co-infiltrated, for example, gene of interest (culture A) co-infiltrated with the *Agrobacterium* construct carrying a silencing suppressor (culture B), determine the OD₆₀₀ of the resuspended *Agrobacterium* cell pellets for both cultures A and B. Use equation $C_1 V_1 = C_2 V_2$ to determine how much of each culture is needed to make up each of the constructs to V_2 at their respective ODs. Add the volume determined for culture A to the volume determined for culture B and fill up to V_2 with infiltration media. The final OD₆₀₀ for the combined constructs = OD₆₀₀ of culture A + OD₆₀₀ of culture B. For example, if each culture is at OD of 0.25, then the final OD of the combined cultures is 0.5. The OD for each individual construct can be varied as needed. When more than two constructs are combined, the final OD₆₀₀ will equal OD₆₀₀ A + OD₆₀₀ B + OD₆₀₀ C and so forth.
29. The third, fourth, and fifth leaves from the top of the plant are the most important for syringe infiltration.
30. It is important to wear PPE, including safety glasses, when infiltrating plants as the bacterial suspension does sometimes squirt out between the syringe opening and the leaf surface when pressure is applied.
31. Larger culture volumes must be prepared for vacuum infiltration. 5- to 6-week-old plants will infiltrate easier than 4-week-old plants.
32. It is important for the beaker to be filled completely; any space between the beaker and the surface of the aluminum foil-covered pot will make thorough infiltration of the plant difficult.
33. The soil is covered with aluminium foil or perspex to prevent the soil from spilling out during infiltration.
34. Agitate the vacuum chamber gently as the vacuum increases; this is to ensure removal of trapped air bubbles on the leaves. Rapid release of the vacuum is very important for efficient infiltration of leaves.
35. Leaf disks can be clipped by closing the microcentrifuge tube with the leaf in between the lid and the bottom, or a leaf disks can be collected by pressing the leaf onto the lid with a finger. It is suggested to harvest at 3, 5, 7, and 9 dpi to find the best day where the protein of interest is accumulated.
36. Scoop liquid nitrogen into the microcentrifuge tube by holding onto the cap of the tube and submerging the rest of the tube in the liquid nitrogen. Care should be taken to avoid “freezer burns”; PPE should be worn when doing this.

37. Extraction buffer as determined from literature for the protein of interest or extraction in 1× PBS (pH 7.4) is a good starting point. Furthermore, addition of protease inhibitors should also be investigated to maximize protein extraction. If the protein is insoluble, 8 M urea can be used for extraction. Addition of detergents to the extraction buffer can also be investigated to facilitate protein extraction.
38. Place the pestle on top of the leaf material prior to adding the liquid nitrogen—this will prevent the leaves from “boiling” out of the mortar as the liquid nitrogen is added.
39. If 10 g of leaf material is processed, 3 volumes of buffer will constitute a volume of 30 mL.

Acknowledgements

We would like to thank Ed Rybicki, Ann Meyers, and everyone in the Biopharming Research Unit at University of Cape Town for their contribution to the development of the techniques. We acknowledge the National Research Foundation, Department of Science and Technology, the Poliomyelitis Research Foundation, the Medical Research Council, the University of Cape Town Research Committee, the Cancer Research Foundation of South Africa, the PlaProVa project of the EU FP7 initiative, and Era Biotech for funding.

References

1. Rybicki EP (2010) Plant-made vaccines for humans and animals. *Plant Biotechnol J* 8:620–637
2. Fischer R, Stoger E, Schillberg S, Christou P, Twyman RM (2004) Plant-based production of biopharmaceuticals. *Curr Opin Plant Biol* 7:152–158
3. Twyman RM, Schillberg S, Fischer R (2013) Optimizing the yield of recombinant pharmaceutical proteins in plants. *Curr Pharm Des* 19:5486–5494
4. Gleba YY, Tuse D, Giritch A (2014) Plant viral vectors for delivery by *Agrobacterium*. *Curr Top Microbiol Immunol* 375:155–192
5. Sainsbury F, Lavoie PO, D'Aoust MA, Vezina LP, Lomonosoff GP (2008) Expression of multiple proteins using full-length and deleted versions of cowpea mosaic virus RNA-2. *Plant Biotechnol J* 6:82–92
6. Regnard GL, Halley-Stott RP, Tanzer FL, Hitzeroth II, Rybicki EP (2010) High level protein expression in plants through the use of a novel autonomously replicating geminivirus shuttle vector. *Plant Biotechnol J* 8:38–46
7. Maclean J, Koekemoer M, Olivier AJ, Stewart D, Hitzeroth II, Rademacher T, Fischer R, Williamson AL, Rybicki EP (2007) Optimization of human papillomavirus type 16 (HPV-16) L1 expression in plants: comparison of the suitability of different HPV-16 L1 gene variants and different cell-compartment localization. *J Gen Virol* 88(Pt 5):1460–1469
8. Hellens R, Mullineaux P, Klee H (2000) Technical Focus: a guide to *Agrobacterium* binary Ti vectors. *Trends Plant Sci* 5: 446–451
9. Takeda A, Sugiyama K, Nagano H, Mori M, Kaido M, Mise K, Tsuda S, Okuno T (2002) Identification of a novel RNA silencing suppressor, NSs protein of Tomato spotted wilt virus. *FEBS Lett* 532:75–79

A Plant-Based Transient Expression System for the Rapid Production of Malaria Vaccine Candidates

Alexander Boes, Andreas Reimann, Richard M. Twyman, Rainer Fischer, Stefan Schillberg, and Holger Spiegel

1 Introduction

The limited success of past and current malaria vaccine candidates [1] indicates the need for intensive and accelerated research to identify and characterize new antigens that confer protection against infection, clinical manifestation, and even the transmission of malaria [2]. Furthermore, multi-stage-specific cocktails combining key antigens from the different stages of the *Plasmodium falciparum* life cycle may be essential for the development of efficacious malaria vaccines [3]. To determine the suitability of novel vaccine candidates as components of vaccine cocktails, the antigens must be rapidly produced, purified, and characterized in terms of their protective efficacy in animal experiments and/or in vitro assays.

Agrobacterium tumefaciens-based transient expression in plants, using either classical T-DNA vectors [4] or amplification systems based on viral replicons [5], is one of the quickest and most versatile strategies for the production of recombinant proteins [6–8]. Although used predominantly for research and development, these systems have also been implemented for the manufacturing of clinical-grade materials, e.g., the experimental antibody cocktail ZMapp, comprising three chimeric monoclonal antibodies against the Ebola virus surface glycoprotein (EBOV-GP) [9], virus-like particles based on human influenza virus hemagglutinin (HA) [10], and the malaria transmission-blocking vaccine candidate Pfs25 [11]. These emerging applications of transient expression are driven by a desire for rapid and inexpensive vaccine development against poverty-related diseases such as malaria [12, 13].

Here we present a well-established and versatile workflow for *A. tumefaciens*-based transient expression in plants in the context of vaccine development, using the expression of single, multi-domain, and fluorescence-labeled malaria vaccine candidates as case studies. The combination of transient expression with a modular and flexible cloning strategy allows the rapid cloning and expression of multi-domain antigens or DsRed reporter gene fusions by gene stacking, and small to medium scale production without expensive and specialized equipment. We have used this workflow successfully to produce several single and multi-domain malaria vaccine candidates [14–16]. However, the technology is generic and can be applied in any vaccine development scenario where progress is dependent on the rapid production of different candidate antigens for analysis and characterization. Because the downstream purification strategies and functionality assays are highly dependent on the specific antigen, these procedures are not covered in this chapter, but examples of such methods can be found in several reports describing the characterization of plant-derived vaccine candidates [14, 16, 17].

The potential applications of this workflow are illustrated using four examples: (1) the cloning of three individual blood-stage antigens (*PfAMA1-DiCo1-3*) and their transient expression in *Nicotiana benthamiana* plants (separately and as a mixture), (2) the subsequent C-terminal fusion of additional blood-stage antigens (*PfMSP1_19*, *PfRH2a*, and *PfRIPR_EGF7/8*) to the *PfAMA1-DiCo* variants by gene stacking and the generation of stacked fusion antigen constructs comprising proteins and/or domains from the pre-erythrocytic stage (*PfCSP_TSR*), (3) the blood-stage (*PfMSP1_19*, *PfMSP4*, *PfMSP8*, and *PfMSP10*) and sexual-stage protein candidates (*Pf325* and *Pf328*), and (4) the cloning of a single antigen (*PfMSP1_19*) as a C-terminal DsRed fusion protein. For additional information on these proteins and domains (*see Notes 1–10*).

The workflow includes the following procedures:

1. The vectors and cloning strategies to generate expression constructs featuring individual antigens, DsRed–antigen fusion proteins, stacked dual-domain fusion proteins and a panel of stacked multi-domain, multi-stage fusion proteins featuring up to nine different antigens or antigen domains.
2. Techniques for the transformation, screening, and cultivation of recombinant *A. tumefaciens*.
3. Plant cultivation (*N. benthamiana*), syringe and vacuum infiltration as well as incubation.
4. The extraction of recombinant proteins from infiltrated leaf tissue.

2 Materials

2.1 Cloning of the Expression Constructs

1. Bacteria
 - Chemically competent *Escherichia coli* DH5 α (NEB, Frankfurt, Germany).
 - *Agrobacterium tumefaciens* strain GV3101::pMP90RK [GmR, KmR, RifR] [18].
2. Plasmids and synthetic genes
 - pTRAk_cERH [19].
3. Oligonucleotides
4. Enzymes
 - Restriction enzymes NcoI, NotI, and EagI (NEB, Frankfurt, Germany).
 - DNA-modifying enzymes T4 DNA ligase and Antarctic phosphatase (NEB, Frankfurt, Germany).

Please note that the sequences for the construct-specific oligonucleotides (primers) must be added to the target sequence as indicated by dots to allow NcoI/NotI cloning and EagI stacking (Subheading 3.1).

- Construct-specific forward primer introducing EagI/NcoI restriction sites (5'-AAAAAAAAACGGCCGTGGCCATGGCT...-3').
- Construct-specific reverse primer introducing NotI restriction site (5'-...GCGGCCGCTTTTTTTT-3').
- pTRA-backbone-specific forward primer PS5' (5'-GACCCCT CCTCTATATAA GG-3').
- pTRA-backbone-specific reverse primer PS3' (5'-GACCCCT CCTCTATATAA GG-3').

2.2 Buffers and Reagents

1. Lysogeny broth (LB)
 - Tryptone 10 g/L.
 - Yeast extract 5 g/L.
 - NaCl 10 g/L.
 - pH 7.
2. Yeast extract broth (YEB)
 - Beef extract 5 g/L.
 - Yeast extract 1 g/L.
 - Tryptone 5 g/L.
 - Sucrose 5 g/L.
 - MgSO₄ 0.5 g/L.
 - pH 7.

3. 2× infiltration medium
 - Sucrose 100 g/L.
 - Glucose 3.6 g/L.
 - Fertyl[®]-II-Mega fertilizer (Planta, Regenstauf, Germany) 1 g/L.
 - pH 5.4–5.8.
4. Acetosyringone (3',5'-dimethoxy-4'-hydroxyacetophenone) (Sigma Aldrich, Seelze, Germany).
5. Plant extraction buffer (PBS, pH 7.4)
 - NaCl 8 g/L.
 - KCl 0.2 g/L.
 - Na₂HPO₄ 1.44 g/L.
 - KH₂PO₄ 0.24 g/L.
 - pH 7.4.

2.3 Equipment

1. Eppendorf Multiporator (Eppendorf, Hamburg, Germany).
2. Desiccator with connections and tubing (Duran, Wertheim/Main, Germany).
3. Rotary vane vacuum pump RZ 6 (Vacuubrand, Wertheim/Main, Germany).
4. 1-mL Ominifx F syringe (Braun, Melsungen, Germany).
5. Blender (Waring, Tampa, FL, USA).
6. Mortar and pestle (Haldenwanger, Waldkraiburg, Germany).

3 Methods

3.1 Cloning the pTRAcK Expression Constructs

Individual synthetic genes or PCR products encoding selected antigen domains can be inserted into the pTRAcK-ERH vector (Fig. 1) or its variants (*see Note 11*) by NcoI/NotI cloning (Fig. 2a). Subsequent stacking of additional domains can be achieved by inserting EagI/NotI-fragments into NotI-linearized plasmids (Fig. 2b). When using an appropriate EagI sequence context (Subheading 2.1, **item 4**, *see Note 12*), a NotI-site will be reconstituted only at the 5'-end of the fusion gene, allowing the insertion of further domains by repeating the procedure. Similarly, the cloning of DsRed-fusion genes (to generate expression cassettes for tetravalent fluorescence-labeled antigens or antigen domains for different screening approaches), can be achieved by inserting EagI/NotI-fragments into a NotI-linearized plasmid carrying a DsRed cDNA inserted by NcoI/NotI cloning (Fig. 2c). Enzymes should be used according to the manufacturer's instructions in term of the amounts, buffers, and incubation conditions.

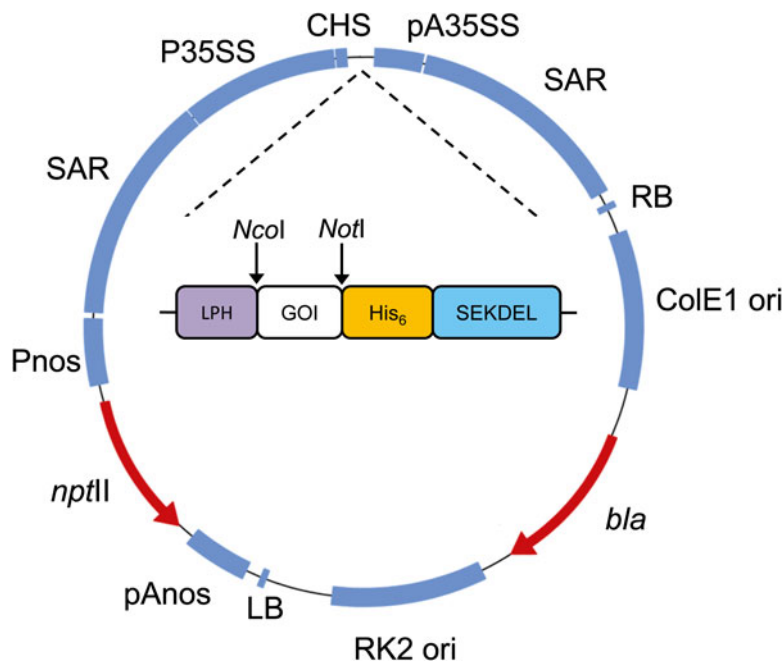

Fig. 1 Features of the plant expression vector pTRAcERH. The plant expression vector pTRAc is a derivative of the pPAM vector (GenBank AY027531) and contains two origins of replication (ColE1 ori for *E. coli* and RK2 ori for *A. tumefaciens*), and a backbone ampicillin resistance gene (*bla*) as a bacterial selection marker. Recombinant proteins are expressed under the control of the *Cauliflower mosaic virus* 35S promoter with duplicated enhancer region, the 5' untranslated region of the *Petrosinella* chalcone synthase (CHS) gene and the CaMV polyadenylation signal (pA35SS). Scaffold attachment regions (SAR) were introduced next to the right and left borders (RB and LB) of the T-DNA to improve gene expression following stable transformation (not relevant for transient expression). For the selection of such stable transgenic tobacco lines, the T-DNA contains the kanamycin resistance gene (*nptII*) under the control of the nopaline synthase promoter (pNos). The cloning cassette in the schematic illustration features the gene of interest (GOI) flanked by *NcoI* and *NotI* restriction sites, in-frame between a signal peptide sequence (LPH) and a His₆ tag (his6) and an ER-retrieval sequence (SEKDEL)

3.1.1 Generation of Single Antigen Expression Constructs

1. Digest 2–4 μg of pTRAc-ERH and target cDNA (insert-specific synthetic gene or PCR product) with *NcoI* and *NotI*.
2. Separate the pTRAc backbone and target cDNA by preparative gel electrophoresis, isolate and purify the DNA fragments.
3. Quantify the purified DNA and use 50–100 ng of pTRAc backbone for ligation with a five to tenfold molar excess of target cDNA (insert-specific synthetic gene or PCR product).

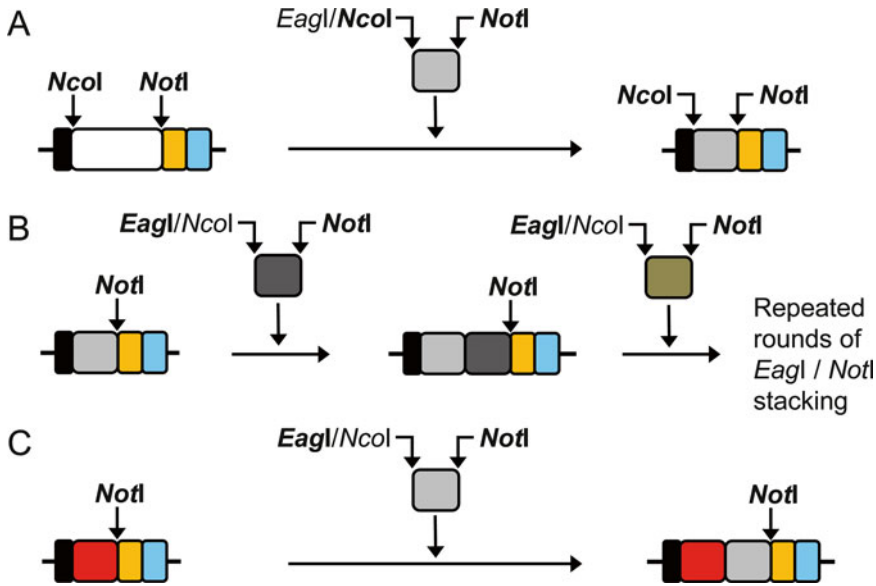

Fig. 2 Modular cloning and gene stacking using pTRAcKc-ERH. Single antigen genes can be inserted in the pTRAcKc-ERH expression cassette by NcoI/NotI cloning (a), leading to the in-frame insertion of the GOI coding sequence (*light gray*) between the 5' signal peptide sequence (*black*) and the 3' His₆ tag (*yellow*), and ER-retrieval sequence (*blue*). The iterative generation of multi-domain fusions (b) can be achieved by subsequent stacking of EagI/NotI-digested GOI fragments into NotI-linearized, de-phosphorylated vectors between a 5' antigen domain (first step, *light gray*; second step, *dark gray*) and the 5' signal peptide sequence (*black*) and the 3' His₆ tag (*yellow*). Fusions to the C-terminus of DsRed (c) can be also realized by inserting EagI/NotI-digested GOI fragments into a NotI-linearized pTRAcKc-ERH vector carrying the DsRed gene (*red*)

3.1.2 Generation of Multi-domain or DsRed Expression Constructs

1. Digest 2–4 μ g of pTRAcKc-ERH containing a single antigen with NotI.
2. Dephosphorylate the linearized vector to avoid re-ligation.
3. Digest target cDNA (insert-specific synthetic gene or PCR product) with EagI.
4. Separate by preparative gel electrophoresis, isolate and purify the DNA fragments.
5. Quantify the purified DNA and use 50–100 ng of pTRAcKc backbone for ligation with a five to tenfold molar excess of target cDNA (insert-specific synthetic gene or PCR product).
6. This step can be repeated to fuse additional antigens or antigen domains (stacking).

Transform chemical competent *E. coli* cells with the ligation reactions, regenerate for 20–60 min at 37 °C and plate on LB agar containing 100 μ g/mL ampicillin. Incubate plates overnight at 37 °C.

3.2 Identification of Recombinant *E. coli* Cells

1. Check recombinant *E. coli* cells either by restriction digest or PCR using the PS5' and PS3' primer pair, or gene-specific primers (*see Note 12*).
2. Verify all cloning steps by DNA sequencing.

3.3 Preparation of Electrocompetent *A. tumefaciens* Cells

1. Inoculate 100 mL of YEB containing 25 µg/mL rifampicin and 25 µg/mL kanamycin with an aliquot of cryopreserved *A. tumefaciens* cells.
2. Grow the culture at 28 °C and 160 rpm for 24–48 h until the OD₆₀₀ reaches ~5.0 (*see* **Notes 13**).
3. Chill cells on ice for 5 min.
4. Transfer cells to two prechilled 50-mL Falcon tubes and centrifuge at 3000×*g* for 10 min.
5. Resuspend each cell pellet in 50 mL ice-cold and sterile H₂O.
6. Repeat the centrifugation step described above, and resuspend each pellet in 25 mL ice-cold and sterile H₂O, and combine both pellets.
7. Repeat the centrifugation step described above, and resuspend the cells in 10 mL ice-cold and sterile 10 % (v/v) glycerol.
8. Repeat **step 7**, but resuspend the cells in 3 mL ice-cold and sterile 10 % (v/v) glycerol and prepare 50-µL aliquots in sterile 1.5-mL reaction tubes.
9. Store reaction tubes with electrocompetent *A. tumefaciens* cells immediately at –80 °C.

3.4 Electroporation of *A. tumefaciens*

1. Thaw an aliquot of electrocompetent *A. tumefaciens* cells on ice.
2. Add 200–500 ng of pTRAcKc plasmid DNA and mix gently with thawed cells.
3. Transfer cells to a prechilled 2-mm electroporation cuvette and apply a pulse of 2.5 kV for 5 ms using an Eppendorf multiporator.
4. Immediately add 950 µL YEB and transfer the cells into sterile 1.5-mL tubes.
5. Incubate the cells for 2–3 h at 28 °C and 160 rpm.
6. Use one spatula to plate, in descending order, 20 µL, 4 µL, and the remaining liquid from the spatula on YEB selection plates containing 50 µg/mL carbenicillin, 25 µg/mL rifampicin, and 25 µg/mL kanamycin (*see* **Notes 14**).
7. Incubate the plates for 3–4 days at 28 °C.

3.5 Identification of Recombinant *A. tumefaciens* Cells

1. Check at least five *A. tumefaciens* clones growing on selection plates by colony PCR (25 µL final reaction volume).
2. Pick a colony (*see* **Notes 15** and **16**) with a standard yellow 200-µL tip, transfer the colony to a YEB master plate containing 50 µg/mL carbenicillin, 25 µg/mL rifampicin, and 25 µg/mL kanamycin and resuspend the colony in 19 µL sterile H₂O in a reaction tube.
3. Incubate the master plate for 1–2 days at 28 °C.

4. Prepare a PCR master mix using 0.5 μL of each primer (PS5' and PS3') and standard PCR ingredients (10 \times PCR buffer, dNTPs, and *Taq* polymerase).
5. Add 6 μL of the PCR master mix to the 19 μL bacterial suspension from **step 2**.
6. Include pTRAKc plasmid DNA as a positive control and H₂O as a negative control, respectively.
7. Run the PCR program shown in Table 1.
8. Analyze PCR products by gel electrophoresis to identify positive recombinant *A. tumefaciens* clones.

3.6 Cultivation of Recombinant *A. tumefaciens* Cells

1. Inoculate 3 mL YEB containing 50 $\mu\text{g}/\text{mL}$ carbenicillin, 25 $\mu\text{g}/\text{mL}$ rifampicin, and 25 $\mu\text{g}/\text{mL}$ kanamycin with a recombinant *A. tumefaciens* colony (see **Note 17**).
2. Incubate at 28 $^{\circ}\text{C}$ and 160 rpm for 48 h.
3. Enlarge the culture to an appropriate volume (see **Note 17**) by adding YEB containing 50 $\mu\text{g}/\text{mL}$ carbenicillin, 25 $\mu\text{g}/\text{mL}$ rifampicin, and 25 $\mu\text{g}/\text{mL}$ kanamycin and cultivate the culture at 28 $^{\circ}\text{C}$ and 160 rpm for 24–48 h to achieve an OD₆₀₀ of 3–6.
4. Prepare glycerol stocks by mixing 500 μL of the culture with 500 μL 100 % (v/v) glycerol and store at -80°C .

3.7 Preparation of Infiltration Solution

1. Determine the OD₆₀₀ of the *A. tumefaciens* culture.
2. Adjust the culture to OD₆₀₀ = 1 with 2 \times infiltration medium and an appropriate volume of sterile H₂O.
3. Add acetosyringone from 200 mM stock solution in DMSO to a final concentration of 200 μM and incubate the infiltration solution for 30 min at room temperature.

Table 1
PCR conditions to identify positive *A. tumefaciens* colonies

Step	Temperature ($^{\circ}\text{C}$)	Time (s)	Repeats
Initial denaturation	95	300	1 \times
Denaturation	95	30	25 \times
Annealing	55	30	
Elongation	72	60/kb	
Final elongation	72	10	1 \times
Storage	20	∞	1 \times

3.8 Cultivation of *N. benthamiana* Plants

1. Germinate *N. benthamiana* seeds preferentially on rock wool blocks using a hydroponic culturing system or in standard soil and pots.
2. Irrigate plants with a 0.1 % (w/v) solution of Fertyl[®]-II-Mega in a greenhouse with 25/22 °C day/night temperature, a 16-h photoperiod and 70 % relative humidity.

3.9 Plant Infiltration and Incubation

Two different infiltration and incubation procedures can be used according to the number of expression constructs and the production scale. (a) Syringe-based infiltration of single or multiple leaves using intact plants (Fig. 3, left panel) and (b) vacuum-based infiltration using intact plants (Fig. 3, right panel). The syringe-based infiltration requires much smaller culture volumes (*see Note 18*) and is more suitable for testing different variants in parallel, whereas vacuum infiltration is typically used for larger-scale production and purification of antigens for detailed characterization (e.g., structural analysis). Note that all work involving genetically modified *A. tumefaciens* must be carried out in an S1 environment, and all materials should be properly decontaminated according to the applicable regulations (*see Note 19*).

3.9.1 Syringe-Based Infiltration

1. Select suitable plants (*see Note 20*) and prepare them for infiltration by misting (*see Note 21*).
2. Place the plant on an autoclavable or disposable tray.
3. Wear a laboratory coat and safety glasses.
4. Aspirate 1 mL infiltration solution into a 1-mL syringe without a needle and position the syringe by pressing the tip with moderate pressure against the lower surface of a suitable leaf (*see Note 22*) close to a main leaf vein. Start infiltrating the solution into the leaf tissue by slowly pushing the solution from the syringe. Infiltrated tissue appears darker and slightly more translucent than non-infiltrated areas (Fig. 3a). Depending on skills and leaf condition, 50–500 µL of solution can be infiltrated into the leaf tissue at one contact point. If the infiltration does not proceed or if the syringe needs to be refilled, change the contact point.
5. Repeat the procedure until the desired number of leaves has been infiltrated.
6. It is possible to use different leaves on the same plant to infiltrate different constructs. In this case, it is important to properly label the leaves and/or contact points and to avoid cross contamination caused by dripping infiltration solution.
7. Transfer plants to a fresh tray and incubate for 3–10 days (Fig. 3b) in a contained growth chamber (16-h photoperiod, 10,000 lx, 22 °C, and 60 % humidity). Check for sufficient watering every 2 days.

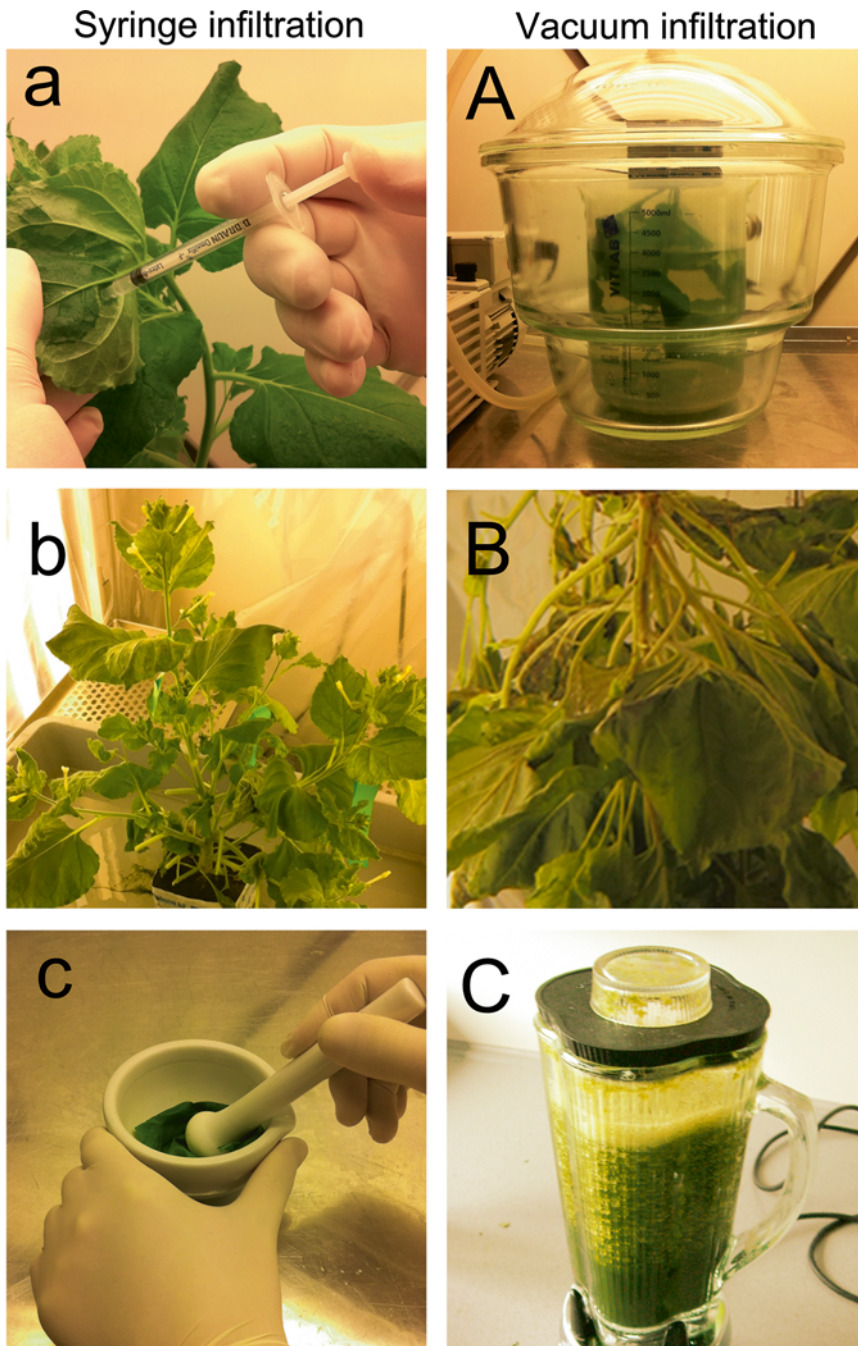

Fig. 3 Infiltration, incubation, and extraction of *N. benthamiana*. *Left panel* shows representative images from the syringe infiltration workflow. (a) Syringe infiltration, as the infiltration solution is slowly pushed into the leaf tissue. Darker areas indicate successfully infiltrated regions. (b) The incubation of a *N. benthamiana* plant (following the syringe infiltration of single leaves) on the shelf of a light cabinet inside a temperature-controlled growth chamber. (c) Small-scale extraction of soluble proteins from leaf tissue using mortar and pestle after syringe infiltration and incubation. *Right panel* shows representative images from the vacuum infiltration workflow. (A) Vacuum infiltration of a whole plant submerged in infiltration solution, inside a desiccator. (B) After vacuum infiltration, plants are incubated hanging upside down within a light cabinet inside a temperature-controlled growth chamber. (C) Soluble proteins from larger amounts of leaf tissue can be extracted using a commercial homogenizer

3.9.2 Vacuum Infiltration

1. Select suitable plants (*see Note 23*) and prepare them for infiltration by misting. Make sure that the plants fit into the infiltration vessel (desiccator).
2. Fill a 5-L plastic beaker with 4 L infiltration solution.
3. Carefully invert each plant and lower into the infiltration solution making sure that all leaves are submerged. Use sticks or adhesive tape to prevent the root block from slipping into the solution (Fig. 3A).
4. Place the beaker with the submerged plant into an appropriate 20–20 L desiccator, close the lid and apply an underpressure of <20 mbar using a vacuum pump.
5. Carefully release the vacuum after 5–10 min (*see Note 24*).
6. Incubate the plants upside down for 3–10 days (Fig. 3B) in a contained growth chamber (16-h photoperiod, 10,000 lx, 22 °C, and 60 % humidity). Check the plants every 2 days for sufficient watering. If the plants appear dry, they should be misted daily.

3.10 Extraction of Total Soluble Proteins

1. Harvest infiltrated leaf material 3–10 days post infiltration (dpi), typically 5 dpi.
2. Weigh the infiltrated leaf material.
3. Grind leaf material to a fine powder in liquid nitrogen using a mortar and pestle for small-scale extraction, and add 2–3 mL of extraction buffer per gram of leaf material (*see Note 25*).
4. For large-scale extraction, use a blender and mix infiltrated leaves with 3 mL extraction buffer per gram of leaf material.
5. Filter the plant crude extract through a double layer of Miracloth.
6. Centrifuge the extract at 40,000×g at 4 °C for 15 min to remove insoluble plant compounds.
7. Tobacco crude extract containing total soluble proteins can be used for subsequent analysis, e.g., SDS-PAGE (Fig. 4a) (*see Note 26*) and immunoblot analysis (Fig. 4b) and/or ELISA. The red fluorescence of DsRed fusion proteins can be observed using a simple red filter with a cold light source and a green excitation filter, *in planta* (Fig. 4c) or after extraction.
8. For purification, adjust the pH of the extract as appropriate and pass the extract through a 0.45-µm filter to avoid clogging the column. The purification strategy for each antigen is highly dependent on its intrinsic properties (*see Note 27*). However, the crude tobacco extract is compatible with most conventional chromatography resins and strategies such as immobilized metal ion affinity chromatography (IMAC).

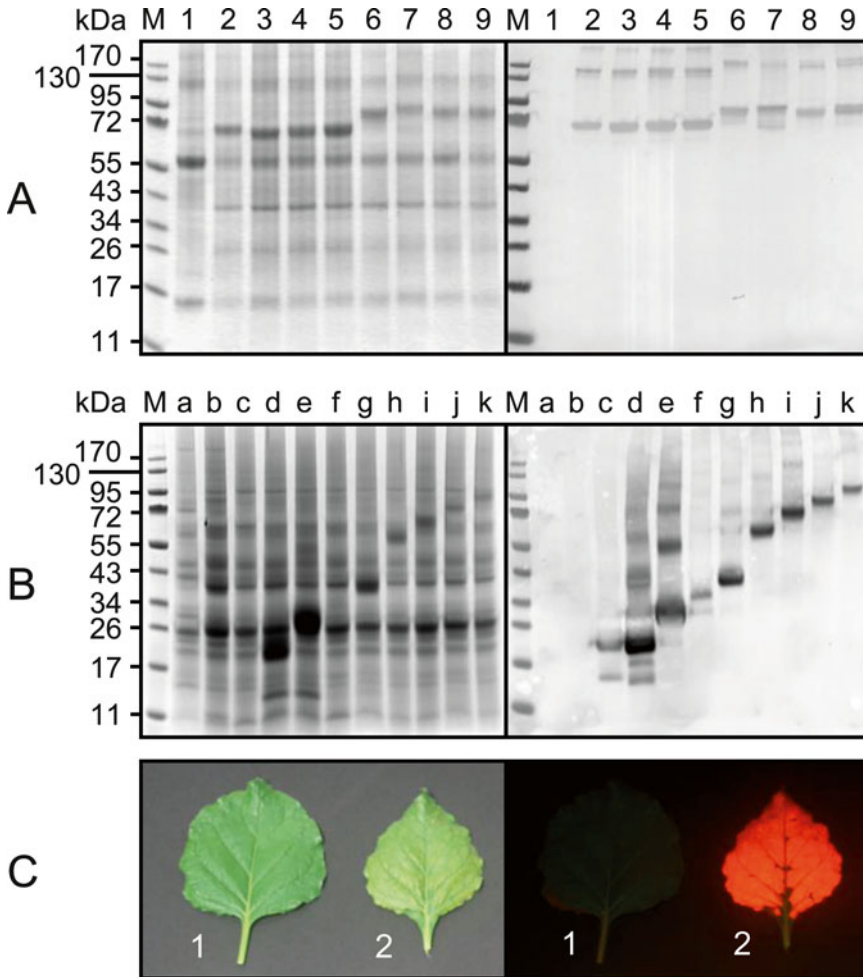

Fig. 4 SDS-PAGE, immunoblot analysis and fluorescence imaging of single and multi-domain malaria vaccine candidates after transient expression in *N. benthamiana*. SDS-PAGE and immunoblot analysis of plant extracts following the expression of different *PfAMA1*-DiCo-based single and dual-domain malaria vaccine antigen constructs. (a) The gel was loaded with 6 μ L of each sample per lane. *M*: Page ruler, pre-stained protein marker; 1: Wild-type plant extract; 2: *PfAMA1*-DiCo1 (61.7 kDa); 3: *PfAMA1*-DiCo2 (61.7 kDa); 4: *PfAMA1*-DiCo3 (61.7 kDa); 5: Mixture of *PfAMA1*-DiCo-1-3 (61.7 kDa); 6: *PfAMA1*-DiCo1-*PfMSP1*₁₉ (72.7 kDa); 7: *PfAMA1*-DiCo2-*PfRH2a* (75.3 kDa); 8: *PfAMA1*-DiCo3-*PfRIPR7/8* (70.6 kDa); 9: Mixture of *PfAMA1*-DiCo1-*PfMSP1*₁₉, *PfAMA1*-DiCo2-*PfRH2a* and *PfAMA1*-DiCo3-*PfRipr7/8* (70.6–75.3 kDa). Samples were separated under non-reducing conditions on a 4–12 % gradient gel (NuPage, Lifetech, Darmstadt, Germany) and subsequently used for immunoblotting. On the SDS-PAGE gel, proteins were visualized by staining with Coomassie Brilliant Blue (a, left panel), on the blot membrane recombinant proteins were detected using a plant-derived rat–human chimeric version of the *PfAMA1*-specific monoclonal antibody 4G2 followed by visualization using an alkaline phosphatase-labeled secondary goat anti-human antiserum (a, right panel). (b) Equivalent SDS-PAGE and immunoblot analysis of a series of stacked multi-domain malaria vaccine candidates, with 15 μ L of samples loaded per lane. *M*: Page ruler, pre-stained protein marker; a: Wild-type plant extract; b: *PfMSP1*₁₉-EGF1 (6.8 kDa); c: *PfMSP1*₁₉-EGF1-*PfMSP8*-EGF1 (12.3 kDa); d: *PfMSP1*₁₉-EGF1-*PfMSP8*-EGF1/2 (17.0 kDa); e: *PfMSP1*₁₉-EGF1-*PfMSP8*-EGF1/2-*PfMSP4*-EGF (22.6 kDa); f: *PfMSP1*₁₉-EGF1-*PfMSP8*-EGF1/2-*PfMSP4*-EGF-*PfMSP10*-EGF1 (28.1 kDa); g: *PfMSP1*₁₉-EGF1-*PfMSP8*-EGF1/2-*PfMSP4*-EGF-*PfMSP10*-EGF1/2 (32.7 kDa);

4 Notes

4.1 Cloning Notes

1. Depending on the origin of the vaccine antigens the preparation of synthetic genes adapted to the codon usage of *N. benthamiana* may be beneficial. AT-rich *P. falciparum* genes in particular may suffer from low expression levels if native cDNA sequences are used. Transient expression using pTRAc-ERH expression plasmids will target recombinant proteins for retention in the endoplasmic reticulum (ER) of the plant cell because the vector provides an N-terminal signal peptide sequence and a C-terminal KDEL-ER retrieval sequence. Therefore, surface-exposed recognition sites for N-linked glycosylation will be post-translationally modified with high-mannose type glycans. Many *P. falciparum* proteins, including many vaccine candidate antigens, contain N-linked glycosylation sites that are not used in the native context because the parasite lacks the corresponding glycosylation machinery [20]. It may therefore be necessary to knock out such N-linked glycosylation sites for the expression of recombinant proteins or protein domains equipped with ER-targeting and retention signals. Depending on the characteristics of the selected antigens, it may be useful to target other subcellular compartments such as the cytosol, vacuole, or plastids. Secreted proteins that require oxidative folding or assembly into homomeric or heteromeric oligomers are suitable for ER-targeting using the pTRAc-ERH vector, whereas cytosolic proteins lacking disulfide bridges and *P. falciparum* proteins from which the N-linked glycosylation sites cannot be removed are candidates for cytosolic targeting using another variant of the pTRA vector lacking the signal peptide and ER-retention sequence [21].
2. The gene stacking strategy takes advantage of the compatibility of the single strand 5' overhangs created by both EagI and NotI. Whereas NotI has an 8-bp recognition site, EagI has a 6-bp recognition site and these features can be used to prevent the reconstitution of a NotI recognition site following the insertion of an EagI-digested fragment. EagI digestion at the

Fig. 4 (continued) *h*: P Δ MSP1-19_EGF1-P Δ MSP8_EGF1/2-P Δ MSP4_EGF-P Δ MSP10_EGF1/2-Pfs25 (51.2 kDa); *i*: P Δ MSP1-19_EGF1-P Δ MSP8_EGF1/2-P Δ MSP4_EGF-P Δ MSP10_EGF1/2-Pfs25-PfCSP_TSR (58.8 kDa); *j*: Pfs28-P Δ MSP1-19_EGF1-P Δ MSP8_EGF1/2-P Δ MSP4_EGF-P Δ MSP10_EGF1/2_Pfs25 (69.9 kDa); *k*: Pfs28_P Δ MSP1-19_EGF1-P Δ MSP8_EGF1/2-P Δ MSP4_EGF-P Δ MSP10_EGF1/2-Pfs25-PfCSP_TSR. Samples were separated in each lane under non-reducing conditions on a 4–12 % (w/v) gradient gel (NuPage, Lifetech) and subsequently used for immunoblotting. (c) Expression of DsRed-antigen fusions can easily be visualized. *1*: Non-infiltrated *N. benthamiana* leaf under white light (*left side*) and under green light visualized through a red filter (*right side*), *2*: *N. benthamiana* leaf infiltrated with DsRed-P Δ MSP1-19 after 5 days of incubation, under white light (*left side*) and under green light visualized through a red filter (*right side*)

5' end and NotI digestion at the 3' end of the stacked insert shifts the NotI site used for stacking to the 3' end of the proximal gene. Two insert orientations are possible and this can be determined by PCR, using an appropriate combination of PS5', PS3', and insert-specific primers that will only generate a product for correct insertion events. Alternatively an NcoI/NotI double digest of the parental and recombinant plasmids will produce identical fragments if the insert is inverted (because the NotI restriction site is reconstituted at the original position), whereas a recombinant plasmid with the correct insert will yield a longer fragment than the parental plasmid.

4.2 *Agrobacterium tumefaciens* Notes

1. *A. tumefaciens* regenerates and grows slowly compared to *E. coli*, especially when inoculated from single colonies. The regeneration times indicated in the protocol should be followed. When inoculating *A. tumefaciens* cultures from glycerol stocks, at least 50–100 μ L should be used to prevent prolonged cultivation times.
2. Strictly avoid incubating *A. tumefaciens* at temperatures exceeding 30 °C because this will lead to the loss of plasmids and thereby reduce the quality and reproducibility of transient expression experiments.
3. Selection plates containing carbenicillin, rifampicin, and kanamycin should be stored at 4 °C for no longer than 10 days.
4. The transformation of electrocompetent *A. tumefaciens* cells with pTRA variants is usually highly efficient. Follow the recommendations regarding plasmid amounts and volumes used for plating the transformed cells to avoid overgrown selection plates.
5. After transformation, do not selectively pick the largest or the smallest colonies on the plate.
6. Do not use wooden toothpicks for the inoculation of liquid cultures with *A. tumefaciens* because phenolic compounds in the stick may inhibit bacterial growth.
7. For troubleshooting, use *A. tumefaciens* transformed with pTRAc-DsRedERH as a reporter plasmid.
8. Adjust the size of the *A. tumefaciens* culture prepared for infiltration according to the amount of leaf tissue that will be infiltrated and the selected infiltration technique. A 20-mL culture usually yields >50 mL infiltration solution sufficient for at least eight leaves using syringe infiltration. When using vacuum infiltration for larger numbers of leaves or whole plants, 4–5 L of infiltration solution is usually required so prepare 500–1000 mL of *A. tumefaciens* culture. Pre-cultures can be expanded up to 100-fold in one step.

4.3 Plant Infiltration Notes

1. To ensure optimal yields in transient expression experiments, avoid the use of plants that show extensive flowering or clear signs of senescence (crinkled leaves or browning).
2. Spraying plants with water mist 20–30 min before starting the infiltration procedure improves the infiltration efficiency, especially when working with syringe infiltration.
3. When aiming to achieve high expression levels on a small scale (e.g., to produce, purify and compare several construct variants), vital leaves of medium age should be chosen. Using the largest lower leaves will generally not increase the protein yield or integrity.
4. Syringe infiltration is useful for the parallel testing of many construct variants, but proper and efficient infiltration of the leaf tissue does require some practice. Do not apply too much force when contacting the lower leaf surface for injection. Infiltrate the *A. tumefaciens* suspension using moderate constant pressure, carefully observe the infiltration of the tissue and proceed to a new contact site if necessary. Wear safety glasses and protective clothing because the *A. tumefaciens* suspension may sputter from the stomata during infiltration.
5. Bubbles will be released from the submerged plant tissues at the beginning of vacuum infiltration. For optimal infiltration, vacuum incubation should continue until bubble formation has ceased. After releasing the vacuum, check the plant for proper infiltration—the infiltrated tissue appears translucent.
6. The whole procedure of *A. tumefaciens* infiltration must be carried out under containment in an appropriate S1 environment.

4.4 Extraction Notes

1. The efficiency of target protein extraction is strongly dependent on the composition of the extraction buffer. The highest extraction efficiency (as a function of total soluble protein content) is achieved with an extraction buffer at neutral pH (7–8) and declines under more acidic or basic extraction conditions. Under basic conditions (especially pH > 8.0), the extract becomes brown as a result of increased enzymatic oxidation and the formation of polyphenolic compounds. Such compounds can hamper subsequent purification steps by promoting the fouling of chromatography resins thus reducing the resin capacity. These issues can be addressed by including an antioxidant such sodium metabisulfite (final concentration 10 mM) in the extraction buffer. Adding NaCl and increasing the conductivity can further increase the solubility of the target protein.
2. The most abundant protein in the crude extract is ribulose-1,5-bisphosphate carboxylase/oxygenase (RuBisCO), a multi-protein complex comprising eight large subunits (approximately 58 kDa) and eight small subunits (approximately 18 kDa).

3. A heat incubation step can be used to reduce the abundance of plant-derived host cell proteins in the extract. Incubation at 70 °C for 10 min typically removes up to 80 % of plant total soluble proteins and may simplify downstream. The applicability of this step depends on the temperature stability of the recombinant target protein. To avoid unfolding of proteins with internal disulfide bridges, an extraction buffer without reducing agents like sodium metabisulfite is highly recommended when applying the heat incubation step.

4.5 Description of the Proteins Used in the Case Studies

1. The three so-called diversity covering (**DiCo**) variants of the apical membrane antigen *PfAMA1* have been developed [22] to cover the high allelic diversity of this promising vaccine candidate with a small number of antigens, aiming to elicit cross-strain-specific parasite growth inhibitory immune responses [23].
2. *PfMSP1_19* is an 11-kDa fragment of an abundant blood-stage antigen, the structural motif occurring in many *P. falciparum* blood-stage antigens. *PfMSP1_19* remains on the surface of the merozoite during erythrocyte invasion underlining the relevance of this antigen as a blood-stage vaccine candidate [24, 25].
3. The RH5 interacting protein (*PfRipr*) is a recently discovered *P. falciparum* surface protein that forms a complex with *PfRH5* and plays a role in the sialic acid-independent erythrocyte invasion pathway [26]. The protein features ten EGF-like domains, and animal studies have indicated that the combination of EFG-7 and EFG-8 is a primary target of protective antibody responses [26].
4. As a member of the *P. falciparum* reticulocyte binding homologs (*PfRH*), *PfRH2* is believed to play a role in the sialic acid-independent erythrocyte invasion pathway and studies have shown that IgGs recognizing the full-size as well as various smaller fragments (e.g., *PfRH2a*) of the protein correlate with protection from symptomatic malaria and high-density parasitemia [27].
5. The merozoite surface protein 4 (*PfMSP4*) is a highly conserved [28], abundant protein found on the surface of *P. falciparum* merozoites [29]. Immunization with a *P. yoelii* homolog of MSP4 resulted in protection from lethal parasite challenge [30]. The C-terminal EGF-like domain is recognized by human immune sera [31].
6. *PfMSP8* is another conserved merozoite surface protein that contains EGF-like domains and has been proposed as potential blood-stage vaccine candidate [32].
7. *PfMSP10* is another merozoite surface protein and potential blood-stage vaccine candidate [33, 34] featuring two EGF-like domains.

8. The two closely related *P. falciparum* ookinete surface proteins **Pfs25** [35] and **Pfs28** [36] have been shown to elicit transmission-blocking antibodies in animal experiments and are among the leading transmission-blocking vaccine candidates. Both proteins contain four EGF-like domains.
9. The circumsporozoite antigen **PfCSP** [37, 38] is the major component of the promising malaria vaccine candidate RTS,S and is regarded as an essential pre-erythrocytic antigen. The C-terminal thrombospondin-related domain **PfCSP_TSR** [39] represents a defined structural entity that **PfCSP** shares with other pre-erythrocytic antigens such as **PfTRAP**, and has been selected as pre-erythrocytic component for the multi-stage vaccine candidates used in our case studies.
10. Variants of the red fluorescent protein (RFP) **DsRed**, initially isolated from the mushroom coral *Discosoma* sp. [40–43], are commonly used as fluorescent marker proteins. **DsRed** forms a homomeric tetramer and the mature protein has an excitation optimum of 554 nm and maximum emission at 554 nm. **DsRed** and its fusion proteins bind copper, and therefore can easily be purified by copper-IMAC. In most cases, **DsRed** tolerates C-terminal fusions and its strong fluorescence allows the expression screening of antigen domain libraries as well as the sorting of antigen specific B-cell populations taking additional advantage of increased avidity resulting from the multivalent presentation within the context of the **DsRed** tetramer.

5 Notes

1. The three so-called diversity covering (**DiCo**) variants of the apical membrane antigen **PfAMA1** have been developed [22] to cover the high allelic diversity of this promising vaccine candidate with a small number of antigens, aiming to elicit cross-strain-specific parasite growth inhibitory immune responses [23].
2. **PfMSP1_19** is an 11-kDa fragment of an abundant blood-stage antigen, the structural motif occurring in many *P. falciparum* blood-stage antigens. **PfMSP1_19** remains on the surface of the merozoite during erythrocyte invasion underlining the relevance of this antigen as a blood-stage vaccine candidate [24, 25]
3. The RH5 interacting protein (**PfRipr**) is a recently-discovered *P. falciparum* surface protein that forms a complex with **PfRH5** and plays a role in the sialic acid-independent erythrocyte invasion pathway [26]. The protein features 10 EGF-like domains, and animal studies have indicated that the combination of

EFG-7 and EFG-8 is a primary target of protective antibody responses [26].

4. As a member of the *P. falciparum* reticulocyte binding homologs (*PfRH*), **PfRH2** is believed to play a role in the sialic acid-independent erythrocyte invasion pathway and studies have shown that IgGs recognizing the full-size as well as various smaller fragments (e.g. *PfRH2a*) of the protein correlate with protection from symptomatic malaria and high-density parasitemia [27].
5. The merozoite surface protein 4 (*PfMSP4*) is a highly-conserved [28], abundant protein found on the surface of *P. falciparum* merozoites [29]. Immunization with a *P. yoelii* homolog of MSP4 resulted in protection from lethal parasite challenge [30]. The C-terminal EGF-like domain is recognized by human immune sera [31].
6. *PfMSP8* is another conserved merozoite surface protein that contains EGF-like domains and has been proposed as potential blood-stage vaccine candidate [32].
7. *PfMSP10* is another merozoite surface protein and potential blood-stage vaccine candidate [33, 34] featuring two EGF-like domains.
8. The two closely related *P. falciparum* ookinete surface proteins *Pf25* [35] and *Pf28* [36] have been shown to elicit transmission-blocking antibodies in animal experiments and are among the leading transmission-blocking vaccine candidates. Both proteins contain four EGF-like domains.
9. The circumsporozoite antigen *PfCSP* [37, 38] is the major component of the promising malaria vaccine candidate RTS,S and is regarded as an essential pre-erythrocytic antigen. The C-terminal thrombospondin-related domain *PfCSP_TSR* [39] represents a defined structural entity that *PfCSP* shares with other pre-erythrocytic antigens such as *PfTRAP*, and has been selected as pre-erythrocytic component for the multi-stage vaccine candidates used in our case studies.
10. Variants of the red fluorescent protein (RFP) **DsRed**, initially isolated from the mushroom coral *Discosoma* sp. [40–43], are commonly used as fluorescent marker proteins. DsRed forms a homomeric tetramer and the mature protein has an excitation optimum of 554 nm and maximum emission at 554 nm. DsRed and its fusion proteins bind copper, and therefore can easily be purified by copper-IMAC. In most cases, DsRed tolerates C-terminal fusions and its strong fluorescence allows the expression screening of antigen domain libraries as well as the sorting of antigen specific B-cell populations taking additional advantage of increased avidity resulting from the multivalent presentation within the context of the DsRed tetramer.

11. Depending on the origin of the vaccine antigens the preparation of synthetic genes adapted to the codon usage of *N. benthamiana* may be beneficial. AT-rich *P. falciparum* genes in particular may suffer from low expression levels if native cDNA sequences are used. Transient expression using pTRAcK-ERH expression plasmids will target recombinant proteins for retention in the endoplasmic reticulum (ER) of the plant cell because the vector provides an N-terminal signal peptide sequence and a C-terminal KDEL-ER retrieval sequence. Therefore, surface-exposed recognition sites for N-linked glycosylation will be post-translationally modified with high-mannose type glycans. Many *P. falciparum* proteins, including many vaccine candidate antigens, contain N-linked glycosylation sites that are not used in the native context because the parasite lacks the corresponding glycosylation machinery [20]. It may therefore be necessary to knock out such N-linked glycosylation sites for the expression of recombinant proteins or protein domains equipped with ER-targeting and retention signals. Depending on the characteristics of the selected antigens, it may be useful to target other subcellular compartments such as the cytosol, vacuole or plastids. Secreted proteins that require oxidative folding or assembly into homomeric or heteromeric oligomers are suitable for ER-targeting using the pTRAcK-ERH vector, whereas cytosolic proteins lacking disulfide bridges and *P. falciparum* proteins from which the N-linked glycosylation sites cannot be removed are candidates for cytosolic targeting using another variant of the pTRA vector lacking the signal peptide and ER-retention sequence [21].
12. The gene stacking strategy takes advantage of the compatibility of the single strand 5' overhangs created by both EagI and NotI. Whereas NotI has an 8-bp recognition site, EagI has a 6-bp recognition site and these features can be used to prevent the reconstitution of a NotI recognition site following the insertion of an EagI-digested fragment. EagI digestion at the 5' end and NotI digestion at the 3' end of the stacked insert shifts the NotI site used for stacking to the 3' end of the proximal gene. Two insert orientations are possible and this can be determined by PCR, using an appropriate combination of PS5', PS3' and insert-specific primers that will only generate a product for correct insertion events. Alternatively an NcoI/NotI double digest of the parental and recombinant plasmids will produce identical fragments if the insert is inverted (because the NotI restriction site is reconstituted at the original position) whereas a recombinant plasmid with the correct insert will yield a longer fragment than the parental plasmid.
13. *A. tumefaciens* regenerates and grows slowly compared to *E. coli*, especially when inoculated from single colonies. The

regeneration times indicated in the protocol should be followed. When inoculating *A. tumefaciens* cultures from glycerol stocks, at least 50–100 μL should be used to prevent prolonged cultivation times.

14. Strictly avoid incubating *A. tumefaciens* at temperatures exceeding 30°C because this will lead to the loss of plasmids and thereby reduce the quality and reproducibility of transient expression experiments.
15. Selection plates containing carbenicillin, rifampicin and kanamycin should be stored at 4°C for no longer than 10 days.
16. After transformation, do not selectively pick the largest or the smallest colonies on the plate.
17. Do not use wooden toothpicks for the inoculation of liquid cultures with *A. tumefaciens* because phenolic compounds in the stick may inhibit bacterial growth.
18. Adjust the size of the *A. tumefaciens* culture prepared for infiltration according to the amount of leaf tissue that will be infiltrated and the selected infiltration technique. A 20-mL culture usually yields >50 mL infiltration solution sufficient for at least eight leaves using syringe infiltration. When using vacuum infiltration for larger numbers of leaves or whole plants, 4-5 L of infiltration solution is usually required so prepare 500-1000 mL of *A. tumefaciens* culture. Pre-cultures can be expanded up to 100-fold in one step.
19. The whole procedure of *A. tumefaciens* infiltration must be carried out under containment in an appropriate S1 environment. To ensure optimal yields in transient expression experiments, avoid the use of plants that show extensive flowering or clear signs of senescence (crinkled leaves or browning).
20. Spraying plants with water mist 20–30 min before starting the infiltration procedure improves the infiltration efficiency, especially when working with syringe infiltration.
21. Syringe infiltration is useful for the parallel testing of many construct variants, but proper and efficient infiltration of the leaf tissue does require some practice. Do not apply too much force when contacting the lower leaf surface for injection. Infiltrate the *A. tumefaciens* suspension using moderate constant pressure, carefully observe the infiltration of the tissue and proceed to a new contact site if necessary. Wear safety glasses and protective clothing because the *A. tumefaciens* suspension may sputter from the stomata during infiltration.
22. When aiming to achieve high expression levels on a small scale (e.g. to produce, purify and compare several construct variants), vital leaves of medium age should be chosen. Using the

largest lower leaves will generally not increase the protein yield or integrity.

23. Bubbles will be released from the submerged plant tissues at the beginning of vacuum infiltration. For optimal infiltration, vacuum incubation should continue until bubble formation has ceased. After releasing the vacuum, check the plant for proper infiltration – the infiltrated tissue appears translucent.
24. The efficiency of target protein extraction is strongly dependent on the composition of the extraction buffer. The highest extraction efficiency (as a function of total soluble protein content) is achieved with an extraction buffer at neutral pH (7–8) and declines under more acidic or basic extraction conditions. Under basic conditions (especially pH >8.0), the extract becomes brown as a result of increased enzymatic oxidation and the formation of polyphenolic compounds. Such compounds can hamper subsequent purification steps by promoting the fouling of chromatography resins thus reducing the resin capacity. These issues can be addressed by including an antioxidant such sodium metabisulfite (final concentration 10 mM) in the extraction buffer. Adding NaCl and increasing the conductivity can further increase the solubility of the target protein.
25. The most abundant protein in the crude extract is ribulose-1,5-bisphosphate carboxylase/oxygenase (RuBisCO), a multi-protein complex comprising eight large subunits (approximately 58 kDa) and eight small subunits (approximately 18 kDa).
26. A heat incubation step can be used to reduce the abundance of plant-derived host cell proteins in the extract. Incubation at 70°C for 10 min typically removes up to 80% of plant total soluble proteins and may simplify downstream. The applicability of this step depends on the temperature stability of the recombinant target protein. To avoid unfolding of proteins with internal disulfide bridges, an extraction buffer without reducing agents like sodium metabisulfite is highly recommended when applying the heat incubation step.

Acknowledgements

We thank Dr. Thomas Rademacher for cloning the pTRAc vector series. The chimeric antibody 4G2 was kindly provided by Stefan Menzel. The work described in this chapter was partly supported by the Fraunhofer Future Foundation via the malaria vaccine project “Innovative technologies to manufacture ground-breaking biopharmaceutical products in microbes and plants”.

References

- Crompton PD, Pierce SK, Miller LH (2010) Advances and challenges in malaria vaccine development. *J Clin Invest* 120:4168–4178
- Vaughan AM, Kappe SHI (2012) Malaria vaccine development: persistent challenges. *Curr Opin Immunol* 24:324–331
- Hill AVS (2011) Vaccines against malaria. *Philos Trans R Soc Lond B Biol Sci* 366:2806–2814
- Davey MR, Gartland KM, Mulligan BJ (1986) Transformation of the genomic expression of plant cells. *Symp Soc Exp Biol* 40:85–120
- Gleba Y, Klimyuk V, Marillonnet S (2007) Viral vectors for the expression of proteins in plants. *Curr Opin Biotechnol* 18:134–141
- Pogue GP, Vojdani F, Palmer KE et al (2010) Production of pharmaceutical-grade recombinant aprotinin and a monoclonal antibody product using plant-based transient expression systems. *Plant Biotechnol J* 8:638–654
- Gleba YY, Klimyuk VV, Marillonnet SS (2005) Magnification—a new platform for expressing recombinant vaccines in plants. *Vaccine* 23:2042–2048
- Santi L, Giritch A, Roy CJ et al (2006) Protection conferred by recombinant *Yersinia pestis* antigens produced by a rapid and highly scalable plant expression system. *Proc Natl Acad Sci U S A* 103:861–866
- Olinger GG, Pettitt J, KIM D et al (2012) Delayed treatment of Ebola virus infection with plant-derived monoclonal antibodies provides protection in rhesus macaques. *Proc Natl Acad Sci U S A* 109:18030–18035
- D’Aoust M-A, Couture MMJ, Charland N et al (2010) The production of hemagglutinin-based virus-like particles in plants: a rapid, efficient and safe response to pandemic influenza. *Plant Biotechnol J* 8:607–619
- Jones RM, Chichester JA, Manceva S et al (2015) A novel plant-produced Pfs25 fusion subunit vaccine induces long-lasting transmission blocking antibody responses. *Hum Vaccin Immunother* 11:124–132
- Klimyuk V, Pogue G, Herz S et al (2014) Production of recombinant antigens and antibodies in *Nicotiana benthamiana* using “magnification” technology: GMP-compliant facilities for small- and large-scale manufacturing. *Curr Top Microbiol Immunol* 375:127–154
- Chichester JA, Manceva SD, Rhee A et al (2013) A plant-produced protective antigen vaccine confers protection in rabbits against a lethal aerosolized challenge with *Bacillus anthracis* Ames spores. *Hum Vaccin Immunother* 9:544–552
- Voepel N, Boes A, Edgus G et al (2014) Malaria vaccine candidate antigen targeting the pre erythrocytic stage of *Plasmodium falciparum* produced at high-level in plants. *Biotechnol J* 9:1435–1445
- Boes A, Spiegel H, Edgus G et al (2015) Detailed functional characterization of glycosylated and nonglycosylated variants of malaria vaccine candidate PfAMA1 produced in *Nicotiana benthamiana* and analysis of growth inhibitory responses in rabbits. *Plant Biotechnol J* 13:222–234
- Beiss V, Spiegel H, Boes A et al (2015) Heat-precipitation allows the efficient purification of a functional plant-derived malaria transmission-blocking vaccine candidate fusion protein. *Biotechnol Bioeng* 112:1297–1305
- Buyel JF, Gruchow HM, Boes A, Fischer R (2014) Rational design of a host cell protein heat precipitation step simplifies the subsequent purification of recombinant proteins from tobacco. *Biochem Eng J* 88:162–170
- Koncz C, Schell J (1986) The promoter of TL-DNA gene 5 controls the tissue-specific expression of chimaeric genes carried by a novel type of *Agrobacterium* binary vector. *Mol Gen Genet* 204:383–396
- Maclean J, Koekemoer M, Olivier AJ et al (2007) Optimization of human papillomavirus type 16 (HPV-16) L1 expression in plants: comparison of the suitability of different HPV-16 L1 gene variants and different cell-compartment localization. *J Gen Virol* 88:1460–1469
- von Itzstein M, Plebanski M, Cooke BM, Coppel RL (2008) Hot, sweet and sticky: the glycobiology of *Plasmodium falciparum*. *Trends Parasitol* 24:210–218
- Wandelt CIC, Khan MRM, Craig SS et al (1992) Vicilin with carboxy-terminal KDEL is retained in the endoplasmic reticulum and accumulates to high levels in the leaves of transgenic plants. *Plant J* 2:181–192
- Remarque EJE, Faber BWB, Kocken CHMC, Thomas AWA (2008) A diversity-covering approach to immunization with *Plasmodium falciparum* apical membrane antigen 1 induces broader allelic recognition and growth inhibition responses in rabbits. *Infect Immun* 76:2660–2670
- Faber BW, Younis S, Remarque EJ et al (2013) Diversity covering AMA1-MSP119 fusion proteins as malaria vaccines. *Infect Immun* 81:1479–1490
- Chappel JA, Egan AF, Riley EM et al (1994) Naturally acquired human antibodies which recognize the first epidermal growth factor-like

- module in the *Plasmodium falciparum* merozoite surface protein 1 do not inhibit parasite growth in vitro. *Infect Immun* 62:4488–4494
25. Kumar S, Collins W, Egan A et al (2000) Immunogenicity and efficacy in aotus monkeys of four recombinant *Plasmodium falciparum* vaccines in multiple adjuvant formulations based on the 19-kilodalton C terminus of merozoite surface protein 1. *Infect Immun* 68:2215–2223
 26. Chen L, Lopaticki S, Riglar DT et al (2011) An EGF-like protein forms a complex with Pfrh5 and is required for invasion of human erythrocytes by *Plasmodium falciparum*. *PLoS Pathog* 7:e1002199
 27. Reiling L, Richards JS, Fowkes FJI et al (2010) Evidence that the erythrocyte invasion ligand Pfrh2 is a target of protective immunity against *Plasmodium falciparum* malaria. *J Immunol* 185:6157–6167
 28. Wang LL, Richie TLT, Stowers AA et al (2001) Naturally acquired antibody responses to *Plasmodium falciparum* merozoite surface protein 4 in a population living in an area of endemicity in Vietnam. *Infect Immun* 69:4390–4397
 29. Gilson PR, Nebl T, Vukcevic D et al (2006) Identification and stoichiometry of glycosylphosphatidylinositol-anchored membrane proteins of the human malaria parasite *Plasmodium falciparum*. *Mol Cell Proteomics* 5:1286–1299
 30. Goschnick MW, Black CG, Kedzierski L (2004) Merozoite surface protein 4/5 provides protection against lethal challenge with a heterologous malaria parasite strain. *Infect Immun* 72:5840–5849
 31. de Silva HD, Saleh S, Kovacevic S et al (2011) The antibody response to *Plasmodium falciparum* Merozoite Surface Protein 4: comparative assessment of specificity and growth inhibitory antibody activity to infection-acquired and immunization-induced epitopes. *Malar J* 10:266
 32. Black CG, Wu T, Wang L et al (2001) Merozoite surface protein 8 of *Plasmodium falciparum* contains two epidermal growth factor-like domains. *Mol Biochem Parasitol* 114:217–226
 33. Black CG, Wang L, Wu T, Coppel RL (2003) Apical location of a novel EGF-like domain-containing protein of *Plasmodium falciparum*. *Mol Biochem Parasitol* 127:59–68
 34. Puentes A, Ocampo M, Rodríguez LE, Vera R (2005) Identifying *Plasmodium falciparum* merozoite surface protein-10 human erythrocyte specific binding regions. *Biochimie* 87:461–472
 35. Vermeulen AN (1985) Sequential expression of antigens on sexual stages of *Plasmodium falciparum* accessible to transmission-blocking antibodies in the mosquito. *J Exp Med* 162:1460–1476
 36. Duffy PE, Kaslow DC (1997) A novel malaria protein, Pfs28, and Pfs25 are genetically linked and synergistic as *falciparum* malaria transmission-blocking vaccines. *Infect Immun* 65:1109–1113
 37. Yoshida N, Nussenzweig RS, Potocnjak P et al (1980) Hybridoma produces protective antibodies directed against the sporozoite stage of malaria parasite. *Science* 207:71–73
 38. Nussenzweig V, Nussenzweig RS (1985) Circumsporozoite proteins of malaria parasites. *Cell* 42:401–403
 39. Plassmeyer ML, Reiter K, Shimp RL et al (2009) Structure of the *Plasmodium falciparum* circumsporozoite protein, a leading malaria vaccine candidate. *J Biol Chem* 284:26951–26963
 40. Campbell RE, Tour O, Palmer AE (2002) A monomeric red fluorescent protein. *Proc Natl Acad Sci U S A* 99:7877–7882
 41. Wall MA, Socolich M, Ranganathan R (2000) The structural basis for red fluorescence in the tetrameric GFP homolog DsRed. *Nat Struct Biol* 7:1133–1138
 42. Shaner NC, Campbell RE, Steinbach PA et al (2004) Improved monomeric red, orange and yellow fluorescent proteins derived from *Discosoma* sp. red fluorescent protein. *Nat Biotechnol* 22:1567–1572
 43. Bevis BJ, Glick BS (2002) Rapidly maturing variants of the *Discosoma* red fluorescent protein (DsRed). *Nat Biotechnol* 20:83–87

Recombinant Botulinum Toxoids: A Practical Guide for Production

Gustavo Marçal S.G. Moreira, Clóvis Moreira Jr., Carlos Eduardo P. da Cunha, Marcelo Mendonça, and Fabricio R. Conceição

1 Introduction

Botulism is a disease caused by toxins produced by *Clostridium botulinum* [1]. This Gram-positive, rod-shaped bacterium is a spore-forming, strict anaerobe that produces a potent neurotoxin classified from serotypes A to H [2]. Despite this classification, botulinum neurotoxins (BoNTs) have similar mechanisms of action, causing severe and often fatal flaccid muscle paralysis due to the inhibition of acetylcholine release into neuromuscular junctions [3]. In animals, BoNT serotypes C and D are the most important, affecting most of the farm animals [4]. All BoNTs are synthesized as a single polypeptide that is cleaved by *C. botulinum* proteases and then connected again by a disulfide bond. Two chains and three domains compose the structure of a 150 kDa active BoNT: the light chain (LC), which comprises the catalytic domain, and the heavy chain (HC), which comprises the translocation and binding domains. LC is a 50 kDa metalloprotease that is connected to the HC by the disulfide bond, while HC is divided in two 50 kDa regions: the N-terminal region (H_N), which is the translocation domain, and the C-terminal region (H_C), which is the binding domain [5, 6]. Several studies have shown that H_C alone is nontoxic [1, 7]. Furthermore, considering the fact that this region is capable of generating high levels of protection when used as vaccine antigen, most of the studies focus on the use of HC [8–10].

The conventional method for the production of vaccines against botulism involves the culture of *C. botulinum*, and further purification and inactivation of the neurotoxins [1, 11]. Since this microorganism is a strict anaerobe and requires special components on its

culture medium, the production process becomes complex [12]. Moreover, *C. botulinum* fermentation involves high biosafety levels, offering intoxication risks to workers. Another drawback is that *C. botulinum* strains show variable yield of toxin production between different batches, causing a problem for the industry. The long time for toxin inactivation (approximately 10 days) and the presence of residual formaldehyde (the most commonly used inactivation agent) in the vaccine are also disadvantages of the conventional process. The production of recombinant vaccines using *Escherichia coli* seems to be the best option to circumvent the shortcomings of the current methods. *E. coli* expression system allows the use of simple media that result in a reproducible high-yield production. Biosafety risks are also not as big as those for *C. botulinum*, since *E. coli* strains used for heterologous expression are not pathogenic and will be used to produce a nontoxic region of the toxin, which dispenses the use of inactivation components such as formaldehyde [7].

Considering this, we describe a method for the production of recombinant vaccines against botulism. Since these vaccines have veterinary applications, they are based on the expression of the non-toxic H_C from BoNT serotypes C and D and thus will be called rH_CC and rH_CD, respectively. Some strategies will be commented on the design and production of recombinant botulinum toxoids using works previously published regarding these two antigens. Moreover, protocols to test the safety and efficacy of the recombinant vaccine will be described following international directives.

2 Materials

2.1 Agarose Gel Electrophoresis

1. *Tris-borate-EDTA (TBE) 5×*: Add about 700 mL of distilled water in a 1 L beaker. Weigh 54 g Tris, 27.5 g boric acid, and 2.92 g EDTA and transfer to the beaker. Mix and adjust pH to 8.0 with HCl and use a graduated cylinder to complete the volume to 1 L. Dilute TBE ten times by adding 100 mL to a graduated cylinder plus 900 mL of distilled water. The working solution is now 0.5×
2. *Ethidium bromide (EtBr)*: Add 5 mL of distilled water in a 15 mL tube. Weigh 100 mg of EtBr and transfer to the tube. Make up to 10 mL with distilled water and use this as a stock solution. For gel staining, dilute the stock solution to 0.5 µg/mL in a volume of TBE 1× that will cover the gel.
3. *Agarose gel*: Add 100 mL of TBE 1× in a heat-resistant flask. Weigh 0.8 g or 1 g of agarose, for 0.8 % and 1 % gels, respectively, and transfer to the flask. Heat the solution in a microwave until agarose is completely dissolved. Cool the solution down in running water to ≈50 °C and pour the solution in the gel template.

4. *DNA loading buffer 6×*: Mix 3 mL glycerol and 7 mL distilled water in a 15 mL tube. Weigh 25 mg of bromophenol blue and transfer to the tube. Make 1 mL aliquots in 1.5 mL tubes.

2.2 Polyacrylamide Gel Electrophoresis

1. *SDS-PAGE loading buffer 4×*: Mix 4 mL glycerol and 2.4 mL Tris-HCl 1 M pH 6.8 in a 15 mL tube. Weigh 0.8 g SDS and 4 mg bromophenol blue, transfer to the solution, and complete the volume to 9.5 mL with distilled water. In a chemical hood, add 0.5 mL of β -mercaptoethanol and make 1 mL aliquots in 1.5 mL tubes. Store at -20°C .
2. *SDS-PAGE running buffer 5×*: Add about 700 mL of distilled water in a 1 L beaker. Weigh 15.1 g Tris, 94.1 g glycine, and 5 g SDS and transfer to the beaker. Mix and adjust pH to 8.3 with HCl. Use a graduated cylinder to complete the volume to 1 L. Dilute the buffer five times by measuring 200 mL to a graduated cylinder more 800 mL of distilled water. The working solution is now 1 \times .
3. *Coomassie Blue staining solution*: Mix 400 mL of distilled water, 500 mL of methanol, and 100 mL of glacial acetic acid in a graduated cylinder and transfer the volume to a 1 L glass beaker. Weigh 1 g of Coomassie Brilliant Blue R-250 or G-250 and transfer to the beaker. Keep the solution under agitation with a magnetic bar for 5 min and filter using a paper filter placed in a funnel.
4. *Destaining solution*: Mix 500 mL of distilled water, 400 mL of methanol, and 100 mL of glacial acetic acid in a graduated cylinder and store in a 1 L glass flask.

2.3 Protein Expression and Purification

1. *Luria-Bertani (LB) medium*: Add about 700 mL of distilled water in a 1 L beaker. Weigh 10 g tryptone, 10 g NaCl, and 5 g yeast extract and transfer to the beaker. Mix and make up to 1 L with distilled water. Autoclave at 121°C for 15 min.
2. *Lysis buffer*: Add about 800 mL of distilled water in a 1 L beaker. Weigh 29.2 g NaCl, 2.34 g NaH_2PO_4 , and 0.68 g imidazole and transfer to the beaker. Mix and adjust pH to 8.0 and make up to 1 L with distilled water. Filter the solution with $0.45\ \mu\text{m}$ membranes and degas using vacuum.
3. *Solubilization buffers (SB)*: For SB-I, add 0.2 g N-lauroylsarcosine for each 100 mL before use. For SB-II, add 0.4 g N-lauroylsarcosine for each 100 mL before use. For SB-III, follow the same instructions for lysis buffer, but add 360 g of urea to the solution.
4. *Elution buffer*: Add about 800 mL of distilled water in a 1 L beaker. Weigh 29.2 g NaCl, 2.34 g NaH_2PO_4 , and 34 g imidazole and transfer to the beaker. Mix and adjust pH to 8.0 and make up to 1 L with distilled water. Filter the solution with $0.45\ \mu\text{m}$ membranes and degas using vacuum. Depending on the fraction that

contains the protein, add the same amount of N-lauroylsarcosine or urea as described for the lysis and solubilization buffers.

5. *PBS 10_x/PBS-T*: Add about 800 mL of distilled water in a 1 L beaker. Weigh 80 g NaCl, 2 g KCl, 14.4 g Na₂HPO₄, and 2.4 g KH₂PO₄ and transfer to the beaker. Mix and adjust pH to 6.8 and make up to 1 L with distilled water. Dilute the buffer ten times by adding 100 mL to a graduated cylinder plus 900 mL of distilled water. The working solution is now 1_x. Add 0.5 mL Tween 20 for each 1 L of PBS 1_x to prepare PBS-T.
6. *PEG 30 %*: Add 100 mL of distilled water in a 0.5 L beaker. Weigh 60 g of PEG 20.000 and transfer to the beaker. Use a graduated cylinder to complete the volume to 200 mL. Store at 4 °C.

2.4 Antigen and Vaccine Characterization

1. *DAB/H₂O₂ solution*: Mix 9 mL Tris-HCl 50 mM pH 7.4 and 1 mL NiSO₄ 0.3% in a 15 mL tube. Weigh 6 mg DAB (3,3'-diaminobenzidine) and transfer to the solution. Add 10 µL of H₂O₂ before use and pour the solution on the blotting membrane. These reagents should be stored at 4 °C prior to use (except DAB).
2. *Thioglycollate broth*: Use commercial formulations and follow manufacturer's instructions. Usually, weigh 29.8 g of the powder and add distilled water to a final volume of 1 L. Autoclave at 121 °C for 15 min.
3. *BHI broth*: Use commercial formulations and follow manufacturer's instructions. Usually, weigh 37 g of the powder and add distilled water to a final volume of 1 L. Autoclave at 121 °C for 15 min.
4. *Sabouraud broth*: Use commercial formulations and follow manufacturer's instructions. Usually, weigh 30 g of the powder, add distilled water to a final volume of 1 L, and adjust the pH to 5.6. Autoclave at 121 °C for 15 min.
5. *Saline solution*: Add about 800 mL of distilled water in a 1 L beaker. Weigh 9 g NaCl, and transfer to the beaker. Mix and make up to 1 L with distilled water. Autoclave at 121 °C for 15 min.
6. *Standard toxins and antitoxins*: These biological materials can be acquired from institutions such as LANAGRO/MAPA (Brazil), NIBSC (UK), USDA (USA), or another competent organ or company.

3 Methods

3.1 Gene Design and Molecular Cloning

1. It is recommended using a synthetic gene containing restriction sites for cloning into the chosen expression vector and *E. coli* codon usage for a more efficient expression. If using *C. botulinum* genome as DNA template to obtain the gene fragment instead of synthesizing it, design primers of 15–25 bp containing restriction sites for cloning. No matter the source

Table 1
Reagents to be added in the digestion reaction

Plasmid DNA ($\approx 1 \mu\text{g}/\mu\text{L}$)	10 μL
Buffer 10 \times	2 μL
First enzyme (10 U/ μL)	1.0 μL
Second enzyme (10 U/ μL)	1.0 μL
H ₂ O	6 μL
<i>Total volume</i>	20 μL

of the gene, make sure the working sequence is from H_C region (*see Note 1*). If using a TOPO-TA cloning vector, there is no need to add the sites for endonucleases (go to **step 7**). If there is no tag added to the 3' region of the resulting gene, the addition of a stop codon in the reverse primer is recommended.

2. Prepare a 20 μL digestion reaction (Table 1) using the two chosen restriction enzymes concomitantly to release the gene from commercial plasmid and to cleave the expression vector (*see Note 2*).
3. Perform the digestion at 37 °C for 1–3 h and run a 0.8 % agarose gel (100 V, 1 h) by adding 4 μL of DNA loading buffer 6 \times to the reaction containing the synthetic gene and load the whole reaction volume into the gel (*see Note 3*). The reaction of the expression vector will be further purified, starting on **step 6**.
4. Leave the gel in EtBr solution for 15–20 min and visualize it in a UV transilluminator.
5. Excise the bands related to the gene of interest (≈ 1300 bp for rH_CC and ≈ 1250 bp for rH_CD) with a blade (scalpel) and transfer the gel to a single 1.5 mL microcentrifuge tube.
6. Purify both the bands from the gel and the reaction containing the expression vector using illustra GFX PCR DNA and gel band purification kit (GE Healthcare) and elute DNA in 20 μL of water.
7. Quantify the DNA on the samples (gene fragments and expression vector) by Qubit fluorometric assay (Life Technologies) using 1 and 2 μL of each sample.
8. Calculate the correct amount of each DNA to be ligated using the equation below and prepare 10 μL of ligation reaction (Table 2) (*see Note 4*):

Table 2
Reagents to be added in the ligation reaction

Vector DNA	50–100 ng
Insert DNA	Use equation below
T4 DNA ligase (5 Weiss U/ μ L)	0.5 μ L
T4 buffer 10 \times	1 μ L
H ₂ O	Up to 10 μ L

$$\text{insert}(\text{ng}) = \frac{\text{vector}(\text{ng}) \times \text{insert size}(\text{kb})}{\text{vector size}(\text{kb})} \times \frac{\text{insert}}{\text{vector}} \text{ molar ratio (1 to 5)}$$

9. Incubate the ligation reaction for 1 h at the temperature recommended by the manufacturer and use 2–3 μ L of the reaction to transform competent *E. coli* strain DH5 α or TOP10 by electroporation using the following parameters: 2.5 kV, 25 μ F, and 200 Ω for 2–3 s (*see Note 5*).
10. Add 1 mL of LB in the electroporation cuvette, transfer the cells to a 1.5 mL microcentrifuge tube, and incubate at 37 $^{\circ}$ C for 1–2 h.
11. Centrifuge the tubes for 1 min at 8,000 $\times g$, leave the pellet in 100 μ L of LB, plate the suspended pellet in LB agar containing the specific antibiotic for the expression vector, and incubate at 37 $^{\circ}$ C for 16–18 h.
12. Transfer growing colonies (approximately 10) to 10 mL of LB containing the proper antibiotic, incubate at 37 $^{\circ}$ C for 16–18 h, and perform plasmid extraction using illustra plasmidPrep spin kit (GE Healthcare). Check for recombinant plasmids by running a 0.8 % agarose gel (100 V, 1 h) (*see Note 6*).
13. Select the clones that showed the higher bands in the gel using as control the vector without insert. Confirm the presence of the proper insert by digestion with the same restriction enzymes used for cloning and/or by sequencing.

3.2 Protein Expression and Solubilization

1. Use 1–2 μ L of the confirmed recombinant plasmid to transform competent *E. coli* BL21 (DE3) cells by electroporation (*see Subheading 3.1, steps 9 and 10*) (*see Note 7*).
2. After incubating transformed cells at 37 $^{\circ}$ C for 1 h, transfer the cells to a 250 mL shake flask containing 50 mL of LB with the proper antibiotics and incubate it at 37 $^{\circ}$ C for 16–18 h 200–250 rpm.
3. Transfer the 50 mL culture to a 2 L shake flask with 450 mL of LB containing the proper antibiotics and grow it at 37 $^{\circ}$ C until OD₆₀₀ reaches 0.6–0.8. When it reaches the OD, separate

5 mL in a 50 mL tube and incubate it under the same conditions to serve as non-induced sample control.

4. Add IPTG to a final concentration of 0.5 mM to the 2 L shake flask and grow for more 4 h at 37 °C (*see Note 8*). Take 1 mL out of the non-induced and induced sample, centrifuge (14,000×*g*, 1 min), and suspend in 100 μL of SDS-PAGE loading buffer 1× (25 μL SDS-PAGE loading buffer 4× + 75 μL sterile H₂O) (*see Note 9*).
5. Centrifuge the culture (10,000×*g*, 15 min, 4 °C) and discard the supernatant (*see Note 10*). Suspend the pellet in 25 mL of lysis buffer containing 50 μg/mL of lysozyme, transfer it to a 50 mL tube, incubate for 1 h at 4 °C, and sonicate (80 Hz) the suspension 5–8 times for 20 s with 10 s of interval between each time.
6. Centrifuge (10,000×*g*, 15 min, 4 °C), save the supernatant, and take out 75 μL to prepare a sample for SDS-PAGE by adding 25 μL of SDS-PAGE loading buffer 4×. Suspend the remaining pellet in 20 mL of SB-I and incubate at 4 °C for 16–18 h under agitation.
7. Repeat **step 6** twice substituting SB-I for SB-II and SB-III, respectively. Please note that when repeating **step 5** it is neither necessary to add lysozyme nor sonicate. These supernatants must be saved.
8. Run a SDS-PAGE loading 10 μL of each non-induced and induced samples, as well as the four fractions of the protein solubilization: soluble (lysis buffer), partially soluble (SB-I and SB-II), and insoluble (SB-III) (*see Note 11*). In this SDS-PAGE, include a negative sample prepared by culturing the non-transformed expression strain in LB for 16 h, centrifuging 500 μL, and suspending the pellet in 100 μL of SDS-PAGE loading buffer 1×; load 10 μL of this control.
9. Stain the gel using Coomassie Blue staining solution and further destain with destaining solution. Select the most soluble fraction in which the protein is visible in SDS-PAGE and perform the purification using Ni²⁺ or Co²⁺ affinity chromatography columns and run another SDS-PAGE to detect eluted proteins.
10. Mix the elution fractions that contain detectable amounts of protein and dialyze against PBS (*see Note 12*).
11. Quantify the protein sample using Bradford assay or BCA protein assay kit (Thermo Scientific). Protein concentration is expected to be at least 0.3 mg/mL. If the concentration is lower, immerge a dialysis bag containing the sample in 300 mL of PEG 30 % solution at 4 °C under slight agitation (≈2 h is sufficient to reduce the volume by half) and quantify the protein again.

12. Distribute the sample in 10 mL vaccine bottles (up to 3 mL per bottle) and store at $-80\text{ }^{\circ}\text{C}$ for further lyophilization. Once lyophilized, samples can be stored at $4\text{ }^{\circ}\text{C}$ for undetermined time (more than 1 year).

3.3 Vaccine Formulation and Safety Test

1. Suspend the lyophilized protein in PBS to a final antigen concentration of $80\text{ }\mu\text{g}/\text{mL}$ (*see Note 13*). The final volume can be 6 mL (more than one bottle can be used).
2. Transfer the volume containing the antigen to a larger recipient, add 6 mL (1:2 dilution) of $\text{Al}(\text{OH})_3 \approx 3\%$, and let it mix for 16–18 h at $25\text{ }^{\circ}\text{C}$ under constant agitation (*see Note 14*).
3. The sterility test is done by culturing 0.5 mL of the vaccine formulation in 20 mL of thioglycollate, BHI, and Sabouraud broths for 21 days (*see Note 15*). Check growth in each media by spectrophotometry at 600 nm daily.
4. Concomitantly with sterility test, perform innocuity test by inoculating 5 mL of the formulation subcutaneously in two guinea pigs weighing 350–450 g (use two different application sites in each animal). Observe local reactions, signs of disease, or possible death for 7 days. If none of these adverse effects occur, the formulation is safe.

3.4 Antigenicity Evaluation and Potency Test

1. For the antigenicity evaluation, perform a dot blot by adding $\approx 3\text{ }\mu\text{g}$ of the recombinant protein (in no more than $5\text{ }\mu\text{L}$) onto a nitrocellulose membrane. As negative control, add the same volume of *E. coli* whole cell lysate and, if possible, a non-related recombinant protein. Let the membrane dry for 5–10 min at room temperature (RT) and block it for 1 h at RT with 5 % skim milk diluted in PBS-T under smooth agitation (*see Note 16*).
2. Dilute standard antibodies to 1 IU/mL in PBS-T and incubate with the membrane for 1 h at RT. Then dilute a peroxidase-conjugated antibody (follow manufacturer's instructions) and incubate with the membrane for 1 h at RT.
3. Develop the reaction by adding DAB/ H_2O_2 solution. If positive reactions develop for the recombinant antigen, it is considered antigenic, and it is likely to work on the potency test.
4. Two groups of 10 guinea pigs should be designed for the potency test. The first group receives 5 mL per dose of the same recombinant vaccine formulation described previously. The second one receives 5 mL per dose of PBS mixed with $\text{Al}(\text{OH})_3$ (negative control). All animals must be immunized subcutaneously in a two-dose scheme on days zero and 21. Bleeding is carried out on day 42 by cardiac puncture and sera obtained by centrifuging the blood ($2,000 \times g$, 7 min) and collecting the supernatant.
5. Make three pools for each group. For the first, mix $600\text{ }\mu\text{L}$ of sera from five of the ten animals (pool A); for the second, mix

Table 3
Volumes to be mixed for seroneutralization assay

IU/mL (serum dilution)	Serum (mL)	Saline (mL)	Toxin 1 L+/mL (mL)
10.0 (1:10)	0.1	0.9	1.0
5.0 (1:5)	0.2	0.8	1.0
2.0 (1:2)	0.5	0.5	1.0
1.0 (1:1)	1.0	–	1.0

600 μ L of the other five sera from the group (pool B); and for the third, mix 1 mL of pool A and B (pool AB).

6. Perform seroneutralization by mixing 1 mL of standardized (1 L+/mL) BoNT with 1 mL of several dilutions of each pool (Table 3). Incubate each mix at 37 °C for 1 h and inoculate 0.2 mL of each dilution in 2 Balb/c mice (18–22 g) intravenously. Make the same dilutions with standard anti-C and D serum (5 IU/mL) as positive control. Observe animals for 72 h counting deaths. The result in IU/mL is the arithmetic mean of the lowest dilution in which both animals die for each of the three pools (*see Note 17*).
7. Repeat **step 6** making intermediate dilutions of each pool to find the exact level of neutralizing antibodies (*see Note 18*).

4 Notes

1. The confirmation of HC should be done by sequencing using primers designed to amplify this region. The steps for both gene and primer design, as well as for molecular cloning are based on protocols previously described [13].
2. It might be necessary to add BSA to the reaction depending on the restriction enzyme brand, thus reducing the volume of H₂O in the reaction. The presented protocol is generic and can be substituted by the manufacturer's one.
3. Many wells or a large one may be used in order to load all digestion volume.
4. A good-quality buffer is essential for a successful ligation reaction. The T4 DNA ligase buffer contains ATP, a crucial component that degrades very fast. So it is recommended to aliquot the buffer before the first use and store at –20 °C (5 μ L aliquots is enough). The first ligation reaction is usually done using insert/vector molar ratio of 3:1, although this proportion can be adjusted if the result is not efficient. Molar ratios may vary from 1:1 to 5:1.

5. Although electroporation is suggested for a more efficient transformation, the simpler heat-shock protocol can also be performed. In a 1.5 mL tube, mix 100 μ L of CaCl_2 0.1 M, 5–10 μ L of competent cells and 2–3 μ L of DNA. Incubate 5 min on ice, transfer quickly to a water bath at 42 °C for 1 min, and transfer again to the ice for 2 min, add 1 mL of LB broth, and incubate for 1–2 h (37 °C, 150–200 RPM). Finally, harvest the cells as previously described and plate them on LB agar with appropriate selection markers.
6. Depending on the type of plasmid used, the protocol for plasmid extraction must be changed. Usually high copy number plasmids (\approx 800 copies per cell) yield high amounts of DNA after purification with commercial kit following the manufacturer's instructions. However, low copy number plasmids (\approx 10 copies per cell) usually require more initial cells for extraction (at least 10 mL of overnight culture). In this case, a Midi Flow kit (GE Healthcare) or a homemade plasmid extraction is suggested.
7. *E. coli* BL21 (DE3) expression system is widely used in molecular biology. Innumerable strains have been developed for different occasions, although the gene expression mechanism is the same. Since there is no general rule for choosing, any strain can be used in this protocol. Anyway, the most common and simpler ones are suggested: *E. coli* BL21 (DE3) itself, Star, pLysS, or pLysE.
8. The expression step is critical for obtaining a good-quality antigen. Both temperature and time after induction can be adjusted in order to improve the process. Usually, there are three options for the temperature-time combination for recombinant BoNT H_C expression: 16–18 °C for 16–22 h, 25–30 °C for 12–30 h, and 37 °C for 3–6 h [7]. This last one is suggested as the first option in this protocol.
9. All SDS-PAGE samples must be boiled (100 °C, 10 min) prior to electrophoresis and kept at –20 °C until further use or after loading into the gel.
10. At this point, the tubes containing the bacterial pellet from expression can be stored at –20 °C up to 72 h.
11. Most of recombinant H_C described in the literature are characterized to be soluble proteins, and thus they should be present in the lysis buffer fraction of this protocol. However, it is possible that at least one of the two H_C mentioned here will be expressed in inclusion bodies and thus will be present in either SB-I, SB-II, or SB-III. rH_CC is more likely to be insoluble than rH_CD, and it is also possible to have these antigens in more than one fraction.
12. Dialysis usually needs to be adapted for each protein. It is recommended to dialyze small volumes (1–2 mL) of the protein

against 1–2 L of PBS in initial trials. If the protein precipitates, dilute the protein samples 1:2, 1:4, and 1:8 (no more than this), and perform direct dialysis the same way. A last tip for direct dialysis is the addition of Triton X-100 (a neutral detergent) to a final concentration of 0.05 % in PBS. Otherwise, a gradual dialysis can be done by reducing the concentration of NaCl on protein solution by adding PBS. For this, use 1–2 mL of the protein against 180 mL elution buffer plus 20 mL PBS in a way that NaCl concentration is 0.45 M. Then, add PBS every 2 h to reduce NaCl concentration by 0.05 each time (Table 4). As a final step, dialyze the protein against 2 L of PBS for 16–18 h. If the protein does not precipitate, repeat the same procedure for larger volumes of the protein (up to 20 mL) using 500 mL of initial volume of the elution buffer and PBS mixture. The volume of PBS in the final step should be increased to 4 L.

13. The protein concentration of 80 µg/mL means that each 2.5 mL has 200 µg of the antigen, which corresponds to one dose of the vaccine. Further, this 2.5 mL will be diluted 1:2 with adjuvant to make a final formulation containing one dose in every 5 mL.
14. Aluminum hydroxide is the most indicated adjuvant for botulinum vaccines, since it rarely causes local reactions or adverse effects and enhances humoral immune responses. However, other adjuvants, such as mineral oil, can be tested for these vaccines, but they are more likely to cause side effects. Moreover, the present protocol can be adjusted for the use of a different adjuvant.

Table 4
Volume of PBS needed to decrease [NaCl] in protein sample during dialysis

[NaCl] (M) ^a	PBS to be added (mL) ^b	PBS to be added (mL) ^c
0.4	25	60
0.35	35	80
0.3	40	110
0.25	60	150
0.2	90	225
0.15	150	375

^aThe NaCl concentration is not considering the amount of NaCl present in the PBS used as diluent

^bThese volumes should be added every 2 h in the same recipient with initial volume of 200 mL (180 mL elution buffer + 20 mL PBS)

^cThese volumes should be added every 2 h in the same recipient with initial volume of 500 mL (450 mL elution buffer + 50 mL PBS)

15. The three given media are the most common used in this step. However, the ones used in this step can be thioglycollate, or Tarozzi, for anaerobic bacteria, and BHI, TSB, or thioglycollate, for aerobic bacteria. Sabouraud medium is the only one used for fungi. Commercial formulations are usually available for these media.
16. During dot blot, it is essential to wash the membrane three times with PBS-T between each step. All incubation steps should be performed under gentle agitation on a rocking platform. If PVDF membrane is used, it should be wet with pure methanol prior to use.
17. In this assay, it is expected to have only two possibilities: or both animals die or survive. If only one of the two animals die, it is possible that the reagents were not manipulated properly or the assay was not conducted correctly. Thus, it must be repeated.
18. The trial described on **step 6** will give an idea of the protection level generated by the recombinant vaccine. The intermediate dilutions will be based on these results; thus, it can be directed to detect levels higher than 10 IU/mL or values between those tested in the first trial. The tip here is that the level of antibodies in IU/mL is related to the serum dilution in saline, for example, a serum diluted 1:20 in saline prior to incubation with standard toxin represents 20 IU/mL of neutralizing antibodies. Moreover, it is indicated to perform individual dilutions instead of serial ones, since intermediate values are not related to each other.

References

1. Smith L (2009) Botulism and vaccines for its prevention. *Vaccine* 27:D33–D39
2. Dover N, Barash JR, Hill KK et al (2014) Molecular characterization of a novel botulinum neurotoxin type H gene. *J Infect Dis* 209:192–202
3. Simpson LL (2004) Identification of the major steps in botulinum toxin action. *Annu Rev Pharmacol Toxicol* 44:167–193
4. Rodloff AC, Krüger M (2012) Chronic *Clostridium botulinum* infections in farmers. *Anaerobe* 18:226–228
5. Adler M (2012) Structural biology. How a neurotoxin survives. *Science* 335:928–929
6. Rossetto O, Pirazzini M, Montecucco C (2014) Botulinum neurotoxins: genetic, structural and mechanistic insights. *Nat Rev Microbiol* 12:535–549
7. Moreira GMSG, Cunha CEP, Salvarani FM et al (2014) Production of recombinant botulinum antigens: a review of expression systems. *Anaerobe* 28:130–136
8. Baldwin MR, Tepp WH, Przedpelski A et al (2008) Subunit vaccine against the seven serotypes of botulism. *Infect Immun* 76:1314–1318
9. Gil LAF, da Cunha CEP, Moreira GMSG et al (2013) Production and evaluation of a recombinant chimeric vaccine against *Clostridium botulinum* neurotoxin types C and D. *PLoS One* 8:e69692
10. Cunha CEP, Moreira GMSG, Salvarani FM et al (2014) Vaccination of cattle with a recombinant bivalent toxoid against botulism serotypes C and D. *Vaccine* 32:214–216
11. Karalewitz AP-A, Barbieri JT (2012) Vaccines against botulism. *Curr Opin Microbiol* 15:317–324
12. Pier CL, Tepp WH, Bradshaw M et al (2008) Recombinant holotoxoid vaccine against botulism. *Infect Immun* 76:437–442
13. Green M, Sambrook J (2012) Molecular cloning: a laboratory manual, 4th edn. Cold Spring Harbor Laboratory Press, Cold Spring Harbor

Part VII

Vaccine Delivery Systems

Chapter 41

Preparation of Multifunctional Liposomes as a Stable Vaccine Delivery-Adjuvant System by Procedure of Emulsification-Lyophilization

Ning Wang and Ting Wang

1 Introduction

Vaccination is the most cost-effective and best prophylactic strategy against many diseases [1]. The conventional vaccines are usually live attenuated or inactivated pathogenic organisms which, after administration, can induce robust immunity in the vaccinated subjects against the related microbes. However, live attenuated pathogens might mutate to be pathogenic and even lead to more severe outcomes; while the inactivated microorganisms may stimulate much weaker and even target-deviated immune response. To overcome the drawbacks associated with conventional vaccines based on whole pathogens, recently subunit vaccines which contain only the essential antigens and, therefore, have defined components are developed, with the anticipation that the potential risks confronted by the conventional vaccines may be reduced [2, 3]. However, due to lack of other microbial components which may not only protect the antigen but also be a pathogen-associated molecular pattern (PAMP) for mammalian immune systems, subunit vaccines are rather unstable and often induce weak immune responses against pathogens. To overcome the weaknesses of subunit vaccines [4], a vaccine carrier with composition mimicking the components of pathogenic organisms has been developed as the vaccine adjuvant-delivery system (VADS) to protect antigens from the environmental damages and even deliver them to specific lymphocytes to initiate effective immune responses [4–6].

Currently, numerous particulate carriers, such as emulsions, liposomes, PLGA particles, silico nanocarriers, and, notably, VLPs (virus-like particles), have been developed as a VADS. In addition, to be recognized and thus taken up by APCs (antigen-presenting

cells), the vaccine carriers are often decorated with PAMP molecules and/or the molecules as ligands to the receptors expressed on the immune cell surfaces, featuring a multifunctional targeting VADS [2, 7–10]. Among various carriers, liposomes have attracted much research interests due to their intrinsic adjuvant properties and the easiness for achieving diverse surface decorations, representing a powerful VADS with some additional advantages of safety, biocompatibility, and wide agent-loading range [11]. Also, various VADS based on multifunctional liposomes have been developed utilizing the specific binding affinities between functional molecules on the carrier and special features expressed or engendered by the aims. For example, recently, we successfully prepared a multifunctional liposome that was dually anchored with a TLR4 ligand lipid A and a synthetic molecule having a distal mannose group and termed mannosylated/lipid A-liposomes (multifunctional liposomes). This kind of multifunctional liposomes proved highly effective in both targeting delivery of vaccine to APCs and enhancing APCs antigen presentation to T-cells [12].

As yet, numerous methods such as film dispersion, solvent (ethanol/ether) injection, reverse evaporation, membrane extrusion, and remote loading have been established by researchers to prepare various categories of liposomes. However, the procedure to produce multifunctional liposomes as a carrier for vaccine antigens should be carefully selected due to the fragile properties associated with the biologically active ingredients. Recently, based on the procedure of emulsification-lyophilization (PEL), we developed different ways for preparing liposomes to entrap a variety of agents with different physicochemical properties [13–18]. The procedures are distinct and the method of lyophilizing O/W emulsions has been proved quite suitable for producing the antigen-loaded liposomes, e.g. the mannose derivative/lipid A dually decorated liposomes, engendering a multifunctional VADS. The procedures involved in PEL is simple and involves four steps: (1) preparation of O/W emulsions with O containing amphiphilic molecules, such as phospholipids, lipid A, and mannose-PEG-cholesterol, as emulsifiers and W containing disaccharides, such as sucrose, lactose, and trehalose, as a lyoprotectant; (2) adding into the emulsions with W containing vaccine antigens and mixing homogeneously; (3) lyophilization of the emulsions to obtain a dry product; (4) rehydration of the dry product with water to form multifunctional liposomes. The fourth step of rehydration can be performed just prior to immunization allowing the vaccine products to be stored in an anhydrous state and applicable to the controlled temperature chain for distribution in remote areas where the integrated cold chain is difficult to maintain [19]. Using phospholipids with a low phase transition temperature as the main membrane materials, the PEL liposomes usually have a size under 300 nm. Considering the PEL step 1 involving sonication to form the O/W emulsions, the antigens to be loaded are

added thereafter in another step to avoid the possible damage by the hard mechanical work; otherwise, the step 2 can be merged with step 1. The AE (association efficiency) of the PEL liposomes can be significantly enhanced if there exists the electrostatic interaction between the charged liposomes and the oppositely charged antigens [20]. Therefore, the cationic/anionic lipids may be included as partial membrane ingredients.

The PEL is an efficient platform to prepare various categories of multifunctional liposomes to form a VADS for different subunit vaccines. Hence, in this chapter we discuss the mannosylated/lipid A-liposomes as an example to introduce the PEL procedure as well as the methods and processes related to synthesis of a mannosylated cholesterol and characterization and quality control of the multifunctional liposomes.

2 Materials and Equipment

2.1 Starting Raw Materials and Equipment

2.1.1 Materials and Equipment for Synthesis and Analysis of the Mannosylated Cholesterol

Various categories of mannose lipoidal derivatives can be synthesized according to the related references. Here, a simple method is introduced to synthesize an APC targeting molecule mannose-PEG-cholesterol using the raw materials: *O*-(2-Aminoethyl)-*O*'-[2-(Boc-amino)ethyl] polyethylene glycol₃₀₀₀ (NH₂-PEG₃₀₀₀-NH-t(Boc)), cholesteryl chloroformate, and 4-isothiocyanatophenyl α -d-mannopyranoside (ITPM).

Mono-tert-butoxycarbonyl poly(ethylene glycol)₃₀₀₀ diamine (NH₂-PEG-NH-t(Boc)) and cholesteryl chloroformate are from Sigma-Aldrich (St. Louis, MO, USA), while 4-isothiocyanatophenyl α -d-mannopyranoside (ITPM) is from Santa Cruz Biotechnology, Inc. (Santa Cruz, TX, USA).

The synthetic compound can be purified by using a dialysis bag with molecular weight cutoff (MWCO) of at least half the MW of the compound to be purified.

The synthetic intermediates and final compound may be identified by TLC using silica gel plates. TLC visualization reagents include phosphotungstic acid for cholesterol and ninhydrin for amine. Phosphotungstic acid and ninhydrin may be obtained from Sigma-Aldrich.

The final synthetic compound may be further verified with Fourier transform infrared spectrophotometer (FTIR) (IRPrestige-21 FTIR Spectrophotometer, Shimadzu, Japan), nuclear magnetic resonance (NMR) spectrometer (Bruker AV400, Switzerland), and matrix-assisted laser desorption/ionization for time-of-flight mass (MALDI-TOF MS) spectrometer (Bruker Autoflex Speed TOF, Germany).

KBr can be used as FTIR sample disk matrix. CDCl₃ is used as sample solvent and TMS for zero ppm reference for NMR. DHB (2,5-dihydroxy benzoic acid), HPA (3-hydroxy picolinic acid) or trans-2-[3-(4-*t*-butyl-phenyl)-2-methyl-2-propenylidene]malononitrile (known as DCTB) may be used as MALDI MS matrix.

2.1.2 *Liposomal Lipids,
Lipoidal
Immunostimulants,
and Selected Buffers*

The membrane ingredients of liposomes are mainly phospholipids and cholesterol. However, to prepare O/W emulsions, the main membrane materials should also be good emulsifiers and can thus be selected from the phospholipids with low gel–liquid crystalline transition temperature (T_c). Therefore, lipids derived from **unsaturated fatty acid** are preferred, e.g., soy phosphatidylcholine (SPC), egg phosphatidylcholine (EPC), 2-dioleoyl-*sn*-glycero-3-phosphocholine (DOPC). In addition, partial inclusion of phosphatidylserine (PS), phosphatidic acid (PA), phosphatidylethanolamine (PE), or phosphatidylglycerol (PG) can usually render liposomes negative charge, while the synthetic cationic lipids, such as dioctadecyldimethylammonium bromide (DDAB), 3β -[*N,N*-dimethylaminoethane]-carbamoyl] cholesterol hydrochloride (DC-Chol), 1,2-dioleoyl-3-trimethylammoniumpropane (DOTAP), and ethylphosphatidylcholine will render liposomes positive charge.

Phosphatidylserine is capable of binding to a specific PS receptor on macrophages, contributing to elicitation of the innate immune response, while other natural lipids are not known to display specific immunological effects, and the adjuvant effect of the liposomes constituted with these lipids is thought to result essentially from their capacity to deliver antigens into APCs [21].

To potentiate the adjuvant effect, liposomes can be incorporated with lipoidal immunostimulants, such as lipopolysaccharide (LPS) [22], monophosphoryl lipid A (MPLA) [14], Quil A and its purified subfraction QS21 [23], muramyl dipeptide (MDP) [24].

To enhance the APC-targeting delivery capacity of the liposomes, lectin binding ingredients, such as mannose receptor ligands, can be anchored onto liposomal membranes. The most commonly used APC-targeting molecules are mannose lipoidal derivatives, including various categories of mannosylated cholesterol/phosphatidylethanolamine [14, 25], mannosylated 1-aminoadamantane and mannosylated adamantyltripeptides [26]. Herein, the synthetic mannosylated cholesterol (mannose-PEG-cholesterol) is introduced as an APC targeting molecule for liposomal carriers [14], with the emphasis of the linking PEG spacer which not only projects the mannose group to be exposed to APCs but also lends liposomes the steric stabilization properties [27].

The phospholipids are from Avanti Polar Lipids (Alabaster, AL, USA), Lipoid (Ludwigshafen, Germany), Genzyme (Liestal, Switzerland), Sigma-Aldrich (St. Louis, MO, USA) (*see Note 2*). The lipids should be stored under nitrogen at ≤ -20 °C from light.

Lipoidal immunostimulants listed above can be obtained from Avanti Polar Lipids, EMC Microcollection (Tuebingen, Germany), Bachem (Bubendorf, Switzerland), InvivoGen (San Diego, CA, USA), Axxora (San Diego, CA, USA), and Sigma-Aldrich among others. Also, the lipoidal immunostimulants should be stored under nitrogen at ≤ -20 °C from light.

The buffers for the preparation of liposomes are phosphate, Tris, and HEPES buffers at pH 7.0 with 5 % sucrose (or other disaccharides) as a lyoprotectant. Buffers are sterilized by autoclave or filtration through 0.2 μm membrane filters.

2.1.3 Equipment for Preparation of O/W Emulsions

Sonicators. The O/W emulsions can be produced with probe or bath type ultrasonicators with the output power of 0–600 W and output frequency of 20 kHz, such as Model 3000 Ultrasonic Homogenizer (Biologics Inc., Manassas, Virginia, USA).

High-pressure homogenizer. The O/W emulsions may also be produced with the EmulsiFlex B15 high-pressure homogenizer (Avestin, Ottawa, Canada).

The sonicator or high-pressure homogenizers are operated according to the operating and safety instructions provided by the manufacturer.

2.1.4 Equipment for Lyophilization

Ultralow temperature refrigerator. The MDF-382E (N) ultralow temperature freezer (Sanyo Electric Co., Ltd., Japan) or other ultralow temperature freezers may be used.

Freeze-dryer. The Eyela Freeze Dryer FDU-2110 (Rikakikai Co., Tokyo, Japan) or other freeze-dryer may be used.

2.2 Materials and Equipment for Characterization of Liposomes

2.2.1 Structure and Morphology Observation by Transmission Electron Microscopy (TEM)

The structure and morphology of the liposomes may be observed by cryo-transmission electron microscopy (cryo-TEM). A FEI Tecna G2 Spirit -transmission electron microscope (FEI Company, Hillsboro, Oregon, USA) and Vitrobot™ Cryo-TEM sample preparation instrument may be used. Liquid nitrogen is the preferred cooling agent.

Alternately, the structure and morphology of the liposomes can be observed by negative staining TEM, using phosphotungstic acid, 5 % ammonium molybdate, or 2 % uranyl acetate as stain agents (Sigma-Aldrich).

2.2.2 Particle Size and Zeta Potential

The size (mean diameter) and zeta potential (ζ) of the multifunctional liposomes with or without antigen can be tested using a Malvern Zetasizer ZS (Malvern, Worcestershire, UK) or other equivalent.

2.2.3 Separation of Free Antigen from Liposomes

The liposomes can be isolated from the free antigens by ultracentrifugation which may be performed on a Micro CS150NX Ultracentrifuge (Hitachi, Japan) or equivalent.

The liposomes and free antigens can also be separated using size exclusion chromatography using the following agents and apparatus: Sephadex G-50 (medium) gel (Pharmacia Company) or equivalent; Glass chromatography column; Liposome buffer for column equilibration and elution.

2.2.4 Extraction of Antigen from Liposomes

1. 0.1 % Triton X-100 (Sigma-Aldrich) in distilled water.
2. Diethyl ether–ethanol, 3:1 vol/vol (Sigma-Aldrich). Prepare and store at room temperature under a chemical hood.
3. Coomassie Brilliant blue G-250 (Sigma-Aldrich).

2.2.5 Determination of Liposomal Antigen

1. Bradford reagent: Dissolve 50 mg of Coomassie Brilliant Blue G-250 in 50 mL ethanol, add 100 mL 85 % (w/v) phosphoric acid (H_3PO_4). Add the acid solution mixture slowly into 850 mL of H_2O and let the dye dissolve completely (*see Note 1*). Filter using Whatman #1 filter paper to remove the precipitates just before use. Bradford reagent should be stored in a dark bottle at 4 °C in a dark place.
2. The absorbance of the stained sample can be tested in 8453 UV–Vis spectrophotometer (Agilent Technologies, Inc., Santa Clara, California, USA) or other equivalent.

2.2.6 HPLC Analysis of Lipids

For quantification, the lipids may be assayed using a gradient HPLC system equipped with an ELSD (evaporative light scattering detector) detector or variable wavelength detector and chromatographic software. Agilent 1100 Series HPLC (Agilent Technologies, Inc.) equipped with the C18 ODS column can be used, but the column should be adapted to the specific lipid composition (*see Note 2*). Mobile phase for gradient elution may include solution B (0.1 % TFA (trifluoroacetic acid) in methanol) and A (0.1 % TFA in water).

2.2.7 SDS–Polyacrylamide Gel Electrophoresis (SDS–PAGE) for Protein Integrity Test

SDS–PAGE experiments can be performed on the freshly prepared 5 % stacking gel and 12 % resolving gel.

For the gel thickness of 0.75 mm, the formulations for the stacking/separating gels, sample loading buffer and electrophoresis running buffer are as follows.

12 % Resolving gel (10 mL): 3.37 mL deionized water, 4.0 mL 30 % acrylamide–bisacrylamide (30:0.8, w/w), 2.5 mL 1.5 M Tris–HCl (pH 8.8), 100 μL 10 % SDS, 25 μL 10 % APS, 5 μL TEMED.

4 % Stacking gel (5 mL): 3.0 mL deionized water, 0.67 mL 30 % acrylamide–bisacrylamide (30:0.8, w/w), 1.25 mL 0.5 M Tris–HCl (pH 6.8), 50 μL 10 % SDS, 25 μL 10 % APS, 5 μL TEMED (*see Note 3*).

2 \times Sample loading buffer: 2 % (w/v) SDS, 10 mM dithiothreitol (or beta-mercaptoethanol), 20 % v/v glycerol, 0.1 M Tris–HCl (pH 6.8), 0.02 % (w/v) bromophenolblue.

1 \times Running buffer: 25 mM Tris–HCl, 200 mM glycine, 0.1 % (w/v) SDS.

All chemicals in the above formulations are globally provided by Sigma-Aldrich.

3 Methods

3.1 Synthesis and Verification of Mannose-PEG-Cholesterol Conjugate (MPC)

3.1.1 Synthesis of NH₂-PEG-NH-CO-O-Cholesterol

The mannose-PEG-cholesterol conjugate (MPC) may be synthesized by two steps: NH₂-PEG-NH-CO-O-cholesterol is first synthesized and then conjugated to a mannose derivative 4-isothiocyanatophenyl α -D-mannopyranoside (ITPM).

NH₂-PEG-NH-CO-O-cholesterol may be synthesized according to a previous report [28].

1. Dissolve H₂N-PEG-NH-t(Boc) (20 μ mol) in 5 mL CHCl₃ (Solution A).
2. Dissolve cholesteryl chloroformate (24 μ mol) in 5 mL CHCl₃ (Solution B).
3. Add Solution A slowly to Solution B at 40 °C with gentle stirring.

TLC analysis (CHCl₃-CH₃OH-NH₃, 90:10:2) of the reaction mixture shows a more polar cholesterol (+) spot. Spray with 20 % phosphotungstic acid in ethanol, heat at 110 °C for 5–15 min or until maximum visualization of the red spots occurs.

4. Add 110 μ L (100 μ mol) of triethylamine into the mixture.
5. Leave the mixture to react for 10 h at 40 °C under nitrogen gas.
6. Remove solvent by evaporation under reduced pressure.
7. Add 5 mL of CHCl₃-Et₂O (1:9, v/v) into the reaction mixture kept at 4 °C overnight.
8. Precipitate the reaction mixture by centrifugation at 5000 $\times g$ for 30 min at 4 °C.

TLC analysis (CHCl₃-CH₃OH-NH₃, 90:10:2) shows cholesterol (+) and amine (-) product. Ninhydrin may be used for detection of amines. Spray with a solution of 0.2 g ninhydrin in 100 mL ethanol and heat to 110 °C until reddish spots appear.

9. Dissolve the sediments in trifluoroacetic acid, (40 % v/v in CHCl₃) and left to react for 20 min at room temperature to eliminate t-Boc group.
10. Wash the reaction mixture three times with distilled water to remove excess trifluoroacetic acid.
11. Dry the chloroform phase with anhydrous sodium sulfate and kept under nitrogen atmosphere.
12. Remove chloroform by vacuum obtaining intermediate NH₂-PEG-NH-CO-O-cholesterol.

TLC analysis (CHCl₃-CH₃OH-NH₃, 90:10:2) shows a single spot cholesterol (+) and amine (+).

3.1.2 Synthesis of Mannose-PEG-Cholesterol Conjugate (MPC)

MPC was prepared from the direct conjugation of NH₂-PEG-NH-CO-O-cholesterol and ITPM (4-isothiocyanatophenyl α -D-mannopyranoside) [29].

1. Add 24 μ mol ITPM in 5 mL DMSO (dimethylsulfoxide) into the synthetic intermediate NH₂-PEG-NH-CO-O-cholesterol.
2. Agitate the mixture at 25 °C for 24 h under nitrogen.
3. Dialysis of the mixture against tenfold volume DMSO thrice to remove unconjugated ITPM using a dialysis bag (*see Note 4*) with molecular weight cutoff (MWCO) in maximum half the MW of the synthetic compound.
4. Dialysis of the synthetic compound-containing dialysis bag against 50-fold volume pure water thrice to remove DMSO.
5. Remove solvent by lyophilization to obtain the synthetic compound powder.

TLC (CHCl₃-CH₃OH-NH₃, 90:10:2) shows cholesterol (+) and amine (-) product and lyophilized to give dry powders.

3.1.3 Identification of the Synthetic Compound by Instrumental Analysis

FTIR:

1. Fully mix 2-mg sample together with 200-mg KBr powder (passing 200-mesh sieve).
2. Compact the powder mixture into a tight disk.
3. Test the sample disk in a FTIR spectrophotometer.

¹H NMR:

1. Dissolve 5 mg sample in 0.6 mL CDCl₃ which contains TMS for zero ppm reference.
2. Test the sample in a NMR spectrometer.

MALDI-TOF MS:

1. Dissolve the synthetic compound in methanol with concentration of 10 mg/mL.
2. Mix 2 μ L of sample methanol solution with 4 μ L of 200 mg/mL DCTB (matrix) methanol solution.
3. Spot 0.5 μ L of sample/matrix solution on the spot plate.
4. Dry the plate to form a transparent spot.
5. Test the samples on the spot plate in a TOF-MS spectrometer.

3.2 Preparation of Multifunctional Liposomes by the Procedure of Emulsification-Lyophilization (PEL)

Lipids having a gel-liquid crystalline transition temperature (T_c) below ambient temperature are preferred membrane materials for the liposomes by PEL procedure because they have high emulsifying capability compared to the lipids with T_c above ambient temperature [16].

1. Preparation of oil phase (O)
Dissolve the lipid materials, e.g. an appropriate amount of PC–MPC–MPLA (100:5:10:1, mole ratio), in cyclohexane or in cyclohexane–chloroform (3:1, v/v) (*see Note 5*).
2. Preparation of water phase (W)
Dissolve sucrose in PBS (50 mM, pH 7.4) to acquire a PBS containing 5 % (w/v) sucrose.
3. Preparation of O/W type emulsion
One part of O is added into three parts of W, and then using an ice/water bath to control the temperature, the mixture is emulsified with a sonicator/high pressure homogenizer to make an O/W type emulsions.
4. Addition of antigen
The O/W type emulsions are diluted with one part of W containing the antigen to be loaded and immediately homogenized by vortex or stirring for 5 min. (The mass ratio of SPC/antigen is maintained at 10:1).
5. Subdivision for lyophilization
The final O/W emulsions are quickly subdivided and filled into 5-mL freeze-drying vials with a fill volume of 1 mL per vial.
6. Freezing
The emulsion-containing vials are immediately transferred into an ultralow temperature refrigerator and frozen at $-85\text{ }^{\circ}\text{C}$ for 4 h.
7. Freeze-drying
The frozen vials are put into a freeze-dryer and lyophilized with a program as follows: primary drying at -45 and $-20\text{ }^{\circ}\text{C}$ for 2 h periods, respectively; and secondary drying at $20\text{ }^{\circ}\text{C}$ for 4 h.
8. Storage
After the freeze-drying process, the vials were immediately filled with nitrogen gas, sealed, and stored protected from light at room temperature.
9. Construction of multifunctional liposomes
An appropriate amount (0.5–3 mL) of water is added into the vial containing the lyophilized powder forming the multifunctional liposomes.

3.3 Characterization of the Multifunctional Liposomes

The morphology and structure of the multifunctional liposomes may be observed by negative staining TEM and may be more veritably visualized by cryo-TEM. The hydrophobic carbon grid can be firstly converted to hydrophilic nature by glow discharge [30].

3.3.1 Cryo-TEM of Multifunctional Liposomes

For cryo-TEM, the sample-holding grid is freeze-dried in liquid nitrogen at $-196\text{ }^{\circ}\text{C}$ for 10 min and transferred to a cryo-holder, which is maintained at ultralow temperature using a liquid nitrogen

storage box, and then inserted in the microscope for imaging in the ultralow temperature (*see Note 6*).

1. An aliquot (1–3 μL) of the sample is applied to an EM grid using a pipet.
2. Blot the sample loaded grid using filter paper to remove excess sample.
3. Plunge the sample loaded grid into liquid nitrogen at $-196\text{ }^{\circ}\text{C}$ for 10 min.
4. Transfer the sample-loaded grid to a cryo-holder, which can be maintained at ultralow temperature using a liquid nitrogen storage box.
5. Insert the cryo-holder into the EM column that is maintained at liquid nitrogen temperature (77 K).
6. Image the sample at the ultralow temperature.

3.3.2 Negative Staining TEM of Multifunctional Liposomes

1. Drop 5 μL of liposome suspensions on a collodion-coated grid.
2. Draw off water with filter paper.
3. A drop of 1 % (w/v) phosphotungstic acid (or 5 % ammonium molybdate, or 2 % uranyl acetate) is applied to the grid.
4. Draw off with filter paper and allow the stained samples to dry.
5. Observe and image the sample-loaded grids in a transmission electron microscope.

3.3.3 Detection of the Size and Zeta Potential of Multifunctional Liposomes

The size (mean diameter) and zeta potential (ζ) of the multifunctional liposomes with or without antigen are tested using a Malvern Zetasizer ZS90 (Malvern, Worcestershire, UK). For size DLS (dynamic light scattering) and ζ ELS (electrophoretic light scattering) tests the scattering light is collected at an angle of 90° , and the temperature is set to $25\text{ }^{\circ}\text{C}$.

3.4 Quantification of Components of Multifunctional Liposomes

Free antigen may also be separated from antigen-containing liposomes by ultracentrifugation.

3.4.1 Separation of Unassociated Antigen, MPLA, and MPC from Liposomes

1. Centrifuge the liposome sample at $100,000\times g$ for 1 h and collect supernatant containing free antigen.
2. Wash the liposomal pellet in liposome buffer by centrifugation as above.

3.4.2 Extraction of Antigen from Liposomes

The extraction of antigens from liposomal formulations can be performed according to the following method.

1. Adjust sample volume containing between 5 and 50 μg of proteins to a final volume of 1 mL with distilled water.

2. Add 0.1 mL of 0.1 % Triton X-100 solution and vortex for 5 min at room temperature to disassemble liposomes.
3. Add 0.1 mL of 72 % trichloroacetic acid, vortex for 2 min, and centrifuge for 15 min in an Eppendorf benchtop centrifuge at $5000 \times g$ to precipitate antigens.
4. Discard supernatant and wash pellet in 1 mL diethyl ether/ethanol (3:1 v/v).
5. Recover protein by centrifugation for 45 min at $10,000 \times g$ in an Eppendorf benchtop centrifuge.
6. Dissolve the antigen pellet in PBS for further assay.

3.4.3 Quantification of Antigens by Bradford Assay

The antigens isolated or extracted from liposomes can be quantitatively determined with the classical Bradford protein assay method [31].

Standard assay procedure (for sample with 25–250 $\mu\text{g}/\text{mL}$ protein)

1. Prepare five to eight dilutions of a protein (usually BSA) standard with a range of 25–250 $\mu\text{g}/\text{mL}$ protein.
2. Dilute unknown protein samples to obtain 10–100 μg protein/30 μL . Add 30 μL each standard solution or unknown protein sample to an appropriately labeled test tube. Set two blank tubes: One for a standard curve, add 30 μL H_2O instead of standard solution. One for unknown protein samples, add 30 μL protein preparation buffer instead. Protein solutions are normally assayed in duplicate or triplicate.
3. Add 1.5 mL of Bradford reagent to each tube and mix well.
4. Incubate at room temperature for at least 5 min. Absorbance will increase over time; samples should incubate at room temperature for no more than 1 h.
5. Measure absorbance at 595 nm.

Microassay procedure (0.1–25.6 $\mu\text{g}/\text{mL}$ protein)

1. Prepare five standard solutions (1 mL each) containing 0, 0.1, 0.4, 1.6, 6.4, and 25.6 $\mu\text{g}/\text{mL}$ BSA.
2. Pipet 800 μL of each standard and sample solution (containing for $<50 \mu\text{g}/\text{mL}$ protein) into a clean, dry test tube. Protein solutions are normally assayed in duplicate or triplicate.
3. Add 200 μL of dye reagent concentrate to each tube and vortex.
4. Follow the procedure described above for the standard assay procedure.

3.4.4 Quantification of Liposomal Lipid Composition

In fact, lipids and lipoidal adjuvants can be very efficiently incorporated into liposomes [14], it is usually unnecessary to determine the unassociated lipid compositions.

The MPLA, MPC and phospholipids may be freed from liposomes by dissolving the centrifuge ($300,000\times g$) pellet of liposomes in methanol and then determined by HPLC system equipped with ELSD detector, column oven, and (not necessarily) auto sampler. An ODS column (4.6 mm \times 150 mm, 5 μ m particle diameter) may be used with the mobile phase: gradient of B (0.1 % TFA (trifluoroacetic acid) in methanol) in A (0.1 % TFA in water).

3.4.5 Antigen Integrity Investigation

The integrity of antigen or antigen in the multifunctional liposomes which are constructed from the lyophilized products is tested through sodium dodecyl sulfate polyacrylamide gel electrophoresis (SDS-PAGE) under reducing conditions.

1. Add equivalent volume of 1 % Triton X-100 into liposome suspensions to free the loaded antigens.
2. Mix one part of the antigen-freed sample with one part of 2 \times Sample-loading Buffer which containing SDS and 2-mercaptoethanol.
3. Heat the antigen containing sample to 95 $^{\circ}$ C for 5 min to denature.
4. Load the heated samples into the wells of the vertical slab gel (5 % stacking gel over 12 % resolving gel) fixed in glass plates which had been placed in the electrophoresis buffer-containing chamber.
5. Start electrophoresis at 80 mV for 30 min and then at 120 mV until the indicator bromophenol blue reached the bottom of the plate using a Bio-Rad mini protean II dual slab cell (Bio-Rad, Hemel Hempstead, UK).
6. Remove gels from the glass plates into a petri dish and wash with pure water thrice.
7. Replace the washing water with Coomassie Brilliant Blue solution (Bradford reagent) for staining the gels to display the antigen and any degraded peptides (*see Note 7*).

4 Notes

1. Do not add H₂O into the 100 mL 85 % (w/v) H₃PO₄ to avoid a rapid increase in temperature due to large heat release during dilution.
2. For charged lipids, IE-HPLC using an appropriate ion exchange column is usually preferred.
3. 30 % acrylamide–bisacrylamide (30:0.8, w/w) aqueous solution should be stored in the dark for less than a month. 10 % APS solution always should be prepared freshly. Caution: Acrylamide is a neurotoxin, so always wear gloves, safety

glasses, and a surgical mask when working with acrylamide powder. Abbreviations: APS, ammonium persulfate; TEMED, tetramethylethylenediamine.

4. The regenerated cellulose (not cellulose ester) dialysis membranes having a good chemical compatibility for organic solvents, such as DMSO, should be selected.
5. The lipid materials may be dissolved in cyclohexane mono-solvent alone if the lipids are readily soluble in the solvent. Otherwise, dissolve the lipid materials in chloroform and then diluted with cyclohexane with the least cyclohexane/chloroform volume ratio of 3:1, so that the co-solvent has a melting point of >-40 °C and can be frozen at -85 °C.
6. The process of cryo-TEM sample preparation can be carried out either manually using a simple plunger or automatically using commercially available machines such as an FEI Vitrobot (Hillsboro, OR).
7. Other color developing chemicals may also be used depending on the antigen properties.

Acknowledgements

The authors acknowledge that this work was financially supported by the Faculty S&R Project Startup Fund of Hefei University of Technology (HUT), and also by the Fundamental Research Funds for the Central Universities for HUT.

References

1. Ozawa S, Mirelman A, Stack ML, Walker DG, Levine OS (2012) Cost-effectiveness and economic benefits of vaccines in low- and middle-income countries: a systematic review. *Vaccine* 31(1):96–108. doi:[10.1016/j.vaccine.2012.10.103](https://doi.org/10.1016/j.vaccine.2012.10.103), S0264-410X(12)01576-9 [pii]
2. Moyle PM, Toth I (2013) Modern subunit vaccines: development, components, and research opportunities. *ChemMedChem* 8(3):360–376. doi:[10.1002/cmdc.201200487](https://doi.org/10.1002/cmdc.201200487)
3. Pham TT, Barratt G, Michel JP, Loiseau PM, Saint-Pierre-Chazalet M (2013) Interactions of antileishmanial drugs with monolayers of lipids used in the development of amphotericin B-miltefosine-loaded nanocochleates. *Colloids Surf B Biointerfaces* 106:224–233. doi:[10.1016/j.colsurfb.2013.01.041](https://doi.org/10.1016/j.colsurfb.2013.01.041)
4. Plotkin SA (2005) Vaccines: past, present and future. *Nat Med* 11(4 Suppl):S5–S11. doi:[10.1038/nm1209](https://doi.org/10.1038/nm1209), nm1209 [pii]
5. Moyle PM, McGeary RP, Blanchfield JT, Toth I (2004) Mucosal immunisation: adjuvants and delivery systems. *Curr Drug Deliv* 1(4):385–396
6. Schijns VE, Lavelle EC (2011) Trends in vaccine adjuvants. *Expert Rev Vaccines* 10(4):539–550. doi:[10.1586/erv.11.21](https://doi.org/10.1586/erv.11.21)
7. Gebril A, Alsaadi M, Acevedo R, Mullen AB, Ferro VA (2012) Optimizing efficacy of mucosal vaccines. *Expert Rev Vaccines* 11(9):1139–1155. doi:[10.1586/erv.12.81](https://doi.org/10.1586/erv.12.81)
8. O’Hehir RE, Sandrini A, Anderson GP, Rolland JM (2007) Sublingual allergen immunotherapy: immunological mechanisms and prospects for refined vaccine preparation. *Curr Med Chem* 14(21):2235–2244
9. Kweon MN (2011) Sublingual mucosa: a new vaccination route for systemic and mucosal immunity. *Cytokine* 54(1):1–5. doi:[10.1016/j.cyto.2010.12.014](https://doi.org/10.1016/j.cyto.2010.12.014), S1043-4666(10)00797-0 [pii]

10. Kim SH, Lee KY, Jang YS (2012) Mucosal immune system and M cell-targeting strategies for oral mucosal vaccination. *Immune Netw* 12(5):165–175. doi:[10.4110/in.2012.12.5.165](https://doi.org/10.4110/in.2012.12.5.165)
11. Alving CR, Rao M, Steers NJ, Matyas GR, Mayorov AV (2012) Liposomes containing lipid A: an effective, safe, generic adjuvant system for synthetic vaccines. *Expert Rev Vaccines* 11(6):733–744. doi:[10.1586/erv.12.35](https://doi.org/10.1586/erv.12.35)
12. Irache JM, Salman HH, Gamazo C, Espuelas S (2008) Mannose-targeted systems for the delivery of therapeutics. *Expert Opin Drug Deliv* 5(6):703–724. doi:[10.1517/17425247.5.6.703](https://doi.org/10.1517/17425247.5.6.703)
13. Wang N, Wang T, Zhang M, Chen R, Deng Y (2014) Using procedure of emulsification-lyophilization to form lipid A-incorporating cochleates as an effective oral mucosal vaccine adjuvant-delivery system (VADS). *Int J Pharm* 468(1–2):39–49. doi:[10.1016/j.ijpharm.2014.04.002](https://doi.org/10.1016/j.ijpharm.2014.04.002), S0378-5173(14)00230-0 [pii]
14. Wang N, Wang T, Zhang M, Chen R, Niu R, Deng Y (2014) Mannose derivative and lipid A dually decorated cationic liposomes as an effective cold chain free oral mucosal vaccine adjuvant-delivery system. *Eur J Pharm Biopharm* 88:194–206. doi:[10.1016/j.ejpb.2014.04.007](https://doi.org/10.1016/j.ejpb.2014.04.007), S0939-6411(14)00124-6 [pii]
15. Wang T, Deng Y, Geng Y, Gao Z, Zou J, Wang Z (2006) Preparation of submicron unilamellar liposomes by freeze-drying double emulsions. *Biochim Biophys Acta* 1758(2):222–231. doi:[10.1016/j.bbame.2006.01.023](https://doi.org/10.1016/j.bbame.2006.01.023), S0005-2736(06)00033-2 [pii]
16. Wang T, Wang N, Jin X, Zhang K, Li T (2009) A novel procedure for preparation of submicron liposomes-lyophilization of oil-in-water emulsions. *J Liposome Res* 19(3):231–240. doi:[10.1080/08982100902788390](https://doi.org/10.1080/08982100902788390), 909232172 [pii]
17. Wang T, Wang N, Song H, Xi X, Wang J, Hao A, Li T (2011) Preparation of an anhydrous reverse micelle delivery system to enhance oral bioavailability and anti-diabetic efficacy of berberine. *Eur J Pharm Sci* 44(1–2):127–135. doi:[10.1016/j.ejps.2011.06.015](https://doi.org/10.1016/j.ejps.2011.06.015), S0928-0987(11)00218-1 [pii]
18. Wang T, Wang N, Sun W, Li T (2011) Preparation of submicron liposomes exhibiting efficient entrapment of drugs by freeze-drying water-in-oil emulsions. *Chem Phys Lipids* 164(2):151–157. doi:[10.1016/j.chemphyslip.2010.12.005](https://doi.org/10.1016/j.chemphyslip.2010.12.005), S0009-3084(10)00391-9 [pii]
19. Lee BY, Cakouros BE, Assi TM, Connor DL, Welling J, Kone S, Djibo A, Wateska AR, Pierre L, Brown ST (2012) The impact of making vaccines thermostable in Niger's vaccine supply chain. *Vaccine* 30(38):5637–5643. doi:[10.1016/j.vaccine.2012.06.087](https://doi.org/10.1016/j.vaccine.2012.06.087), S0264-410X(12)00977-2 [pii]
20. Ge S, Kojio K, Takahara A, Kajiyama T (1998) Bovine serum albumin adsorption onto immobilized organotrichlorosilane surface: influence of the phase separation on protein adsorption patterns. *J Biomater Sci Polym Ed* 9(2):131–150
21. Haensler J (2010) Liposomal adjuvants: preparation and formulation with antigens. *Methods Mol Biol* 626:73–90. doi:[10.1007/978-1-60761-585-9_6](https://doi.org/10.1007/978-1-60761-585-9_6)
22. Ruyra A, Cano-Sarabia M, Garcia-Valtanen P, Yero D, Gibert I, Mackenzie SA, Estepa A, Maspoch D, Roher N (2014) Targeting and stimulation of the zebrafish (*Danio rerio*) innate immune system with LPS/dsRNA-loaded nanoliposomes. *Vaccine* 32(31):3955–3962. doi:[10.1016/j.vaccine.2014.05.010](https://doi.org/10.1016/j.vaccine.2014.05.010)
23. Leroux-Roels G, Van Belle P, Vandepapeliere P, Horsmans Y, Janssens M, Carletti I, Garcon N, Wettendorff M, Van Mechelen M (2014) Vaccine adjuvant systems containing monophosphoryl lipid A and QS-21 induce strong humoral and cellular immune responses against hepatitis B surface antigen which persist for at least 4 years after vaccination. doi:[10.1016/j.vaccine.2014.10.078](https://doi.org/10.1016/j.vaccine.2014.10.078)
24. Jain V, Vyas SP, Kohli DV (2009) Well-defined and potent liposomal hepatitis B vaccines adjuvanted with lipophilic MDP derivatives. *Nanomedicine* 5(3):334–344. doi:[10.1016/j.nano.2008.12.004](https://doi.org/10.1016/j.nano.2008.12.004)
25. Foged C, Arigita C, Sundblad A, Jiskoot W, Storm G, Frokjaer S (2004) Interaction of dendritic cells with antigen-containing liposomes: effect of bilayer composition. *Vaccine* 22(15–16):1903–1913. doi:[10.1016/j.vaccine.2003.11.008](https://doi.org/10.1016/j.vaccine.2003.11.008)
26. Stimac A, Segota S, Dutour Sikiric M, Ribic R, Frkanec L, Svetlicic V, Tomic S, Vranesic B, Frkanec R (2012) Surface modified liposomes by mannosylated conjugates anchored via the adamantyl moiety in the lipid bilayer. *Biochim Biophys Acta* 1818(9):2252–2259. doi:[10.1016/j.bbame.2012.04.002](https://doi.org/10.1016/j.bbame.2012.04.002)
27. Perouzel E, Jorgensen MR, Keller M, Miller AD (2003) Synthesis and formulation of neoglycolipids for the functionalization of liposomes and lipoplexes. *Bioconjug Chem* 14(5):884–898. doi:[10.1021/bc034068q](https://doi.org/10.1021/bc034068q)
28. Carrion C, Domingo JC, de Madariaga MA (2001) Preparation of long-circulating immunoliposomes using PEG-cholesterol conjugates: effect of the spacer arm between PEG and cholesterol on liposomal characteristics. *Chem Phys Lipids* 113(1–2):97–110, S0009308401001785 [pii]

29. Muthiah M, Vu-Quang H, Kim YK, Rhee JH, Kang SH, Jun SY, Choi YJ, Jeong YY, Cho CS, Park IK (2013) Mannose-poly(ethylene glycol)-linked SPION targeted to antigen presenting cells for magnetic resonance imaging on lymph node. *Carbohydr Polym* 92(2):1586–1595. doi:[10.1016/j.carbpol.2012.11.011](https://doi.org/10.1016/j.carbpol.2012.11.011), S0144-8617(12)01116-2 [pii]
30. Harris JR (1999) Negative staining of thinly spread biological particulates. *Methods Mol Biol* 117:13–30. doi:[10.1385/1-59259-201-5:13](https://doi.org/10.1385/1-59259-201-5:13), 1-59259-201-5-13 [pii]
31. Bradford MM (1976) A rapid and sensitive method for the quantitation of microgram quantities of protein utilizing the principle of protein-dye binding. *Anal Biochem* 72:248–254, S0003269776699996 [pii]

Preparation of the Multifunctional Liposome-Containing Microneedle Arrays as an Oral Cavity Mucosal Vaccine Adjuvant-Delivery System

Ting Wang and Ning Wang

1 Introduction

Mucosal vaccination, namely vaccination at mucosas where numerous mucosa-associated lymphoid tissues (MALT) are located, is convenient and has a good compliance with the vaccinees. Effective mucosal vaccination can not only ignite the body to set up the antigen-specific cellular and humoral immunity but also may elicit the body to engender widespread mucosal immunoresponses to the vaccine antigens, establishing a robust multiple defense against the invading pathogens [1]. To be effective, mucosal vaccines must approach the professional antigen-presenting cells (APCs) to induce potent immunoresponses resulting in plentiful functional pathogen-specific antibodies and cytotoxic T lymphocytes (CTLs) to neutralize and lyse the invaded pathogens, such as HIV and HPV, which once enter the cells can rapidly integrate into the host genome forming a latent reservoir that can hardly be eliminated by conventional antiretroviral agents [2].

Notably, the mucosal vaccines that can block the invasion of various intractable pathogens at the initial entering sites are now in most cases, though desirably needed, still in deficiency and are still difficult to develop due to certain big obstacles. Firstly, the mammal mucosas suitable for vaccination are usually covered with a defending layer of mucus which is continuously renewed and contains various categories of agents, such as antiseptic lysozyme, proteinases, and glycoprotein mucins [3], not only imposing a potential damage to vaccine antigens but also preventing mucosal vaccines from approaching and crossing the epithelial layer, under which the professional APCs are sited. Secondly, the tightly-lined epithelial cells with intercellular spaces sealed by tight junctions

also form a barrier to mucosal vaccines to reach the professional APCs which are the necessary sponsors for the immunoresponses to the vaccines.

Compared to other mucosal sites, oral cavity mucosa confronts a mild environment and is easily accessible, relatively safe for vaccination [4], and also enriched in APCs to mediate innate and adaptive immunoresponses to block local and systemic infections [5]. Unfortunately, oral mucosal immunization is further limited by both its anatomic structure of stratified squamous epithelium (SSE) and the rapid clearance of subjects from mucosal surfaces by flow of saliva, movement of tongue and jaws, and chewing and swallowing [6]. To conquer these barriers to oral mucosal delivery, up to now numerous technologies have been developed [6], with two most common and practical strategies being to incorporate a bioadhesive polymer to the carrier [7] and to use permeation enhancers (e.g., a mucolytic agent of *N*-acetyl-L-cysteine); however, the paraesthesia caused by bioadhesive leading to saliva supersecretion and thus vaccine loss and the undermined mucosa compromise the feasibility of either method [8]. Recently, researchers modified nanoparticles with PEG as so-called mucus-penetrating particles (MPPs) for topical delivery of antibiotics in vagina and proved that MPPs improved vaginal drug distribution and retention over the vaginal epithelium compared to conventional particles [9]. But the enhanced uptake of agents into cells of interest can rarely be expected for such an MPP as PEG is a known barrier to the access by most kinds of cells [10].

Recently, it has been reported that the mannose-PEG-cholesterol (MPC)/lipid A-liposomes (MLLs) can efficiently deliver antigens to APCs forming an effective vaccine adjuvant-delivery system (VADS) [11]. Furthermore, the multifunctional MLLs can be included in the microneedles of a biodegradable microneedle array, engendering the liposome-constituted microneedle arrays (LiposoMAs) which are rather stable and, when given to mice at oral cavity mucosa, can induce robust systemic and wide mucosal immunoresponses against the loaded antigens [12]. The LiposoMAs can eliminate several substantial obstacles confronted by conventional mucosal vaccines or the intradermal microneedle vaccines, e.g., the intradermal microneedle vaccines cannot induce extensive mucosal immunoresponses; the conventional mucosal vaccines are inefficient in penetrating the mucus and underlying tight epithelium of mucosa leading to a large loss of the active ingredients when vaccines are gone with mucus fluids or saliva. Thus, LiposoMAs are a promising mucosal VADS. In this chapter, we introduce the protocols that are involved in the preparation, characterization as well as mucosal inoculation of the LiposoMAs, and also the methods for testing the vaccination efficacy are included.

2 Materials, Equipment, and Animals

2.1 *Materials and Equipment for Making Microneedle Array Inverse Molds (MAIMs)*

Silicon wafers are commercial products by Wafer World Inc. (Palm Beach County, FL, USA). The photoresist of AR-P 3540T is supplied by Allresist GmbH (Strausberg, Germany). The PDMS prepolymer solution of SYLGARD 184 is the products by Dow Corning Corporation (Midland, MI, USA). Potassium hydroxide (KOH) is globally provided by Sigma-Aldrich (St. Louis, MO, USA).

A thin layer of SiO₂ on the surface of silicon wafers is formed by oxidation of the wafer in a Thermco1 Oxidation and Annealing Furnace (Thermco Instrument Corporation, La Porte, IN, USA).

The photoresist is dispersed into a thin layer covering the silicon wafer using a machine of Spin Coater WS-650-23B from Laurell Technologies Corporation (North Wales, PA, USA).

Photolithography patterning is carried out in a High Resolution Mask Alignment and Exposure System of ABM/6/350/NUV/DCCD/BSIR/M (ABM Inc., Silicon Valley, CA, USA).

The reactive ion etching is carried out using BT-1 Industrial Plasma Processing System (Plasma Etch Inc., Carson City, NV, USA). The film thickness is measured non-destructively using a Wyko NT1100 Optical Profiling System (Veeco Instruments Inc., Plainview, NY, USA).

2.2 *Materials and Equipment for Making multifunctional liposomes*

The materials and equipment for making multifunctional liposomes are described in detail in a previous Chapter 42. Briefly, soy phosphatidylcholine (SPC, average MW: 775), monophosphoryl lipid A (LA, average MW: 1763), and stearylamine (SA) are provided by Avanti Polar Lipids, Inc. (Alabaster, USA). Model antigen ovalbumin (OVA) and the MA matrix materials of PVP_{k30} (Polyvinyl pyrrolidone with average MW of 40,000) and sucrose are commercial products by Sigma-Aldrich (St. Louis, MO, USA). The conjugate of mannose-PEG-cholesterol (MPC) with average MW of 1757 is synthesized according to a previous report [11].

2.3 *Materials and Equipment for Cell Culture and Immunological Assay*

HyClone RPMI 1640 medium and fetal calf serum (FCS) are provided by Thermo Fisher Scientific (Waltham, MA, USA). MTT (3-(4,5-dimethylthiazol-2-yl)-2,5-diphenyltetrazolium bromide) and TMB (3,3',5'-tetramethylbenzidine) are commercial products by Sigma-Aldrich (St. Louis, MO, USA). The biological agents for assay of immunoglobulins and cytokines, such as IFN- γ and IL-4 assay kits, goat anti-mouse IgG-horse radish peroxidase (HRP), IgG1-HRP, IgG2a-HRP, and IgA-HRP with sales package of 200 μ g per 0.5 mL, are commercial products by Santa Cruz Biotechnology, Inc. (Dallas, Texas, USA). PE-conjugated anti-mouse CD8⁺ mAb (monoclonal antibody) and FITC-conjugated anti-mouse CD4⁺ mAb and other fluorescently labeled immunological agents for assay are products by eBioscience (San Diego, USA).

3 Methods

3.1 Preparation of the Microneedle Array Inverse Molds (MAIMs)

The biodegradable microneedle arrays (MAs) as vaccine carriers are usually fabricated with the MA inverse molds (MAIMs) which are most commonly made of polydimethylsiloxane (PDMS) and created from the master molds, which are in fact the exact MA replicates and are made by microelectromechanical systems technology from different materials, such as silicon, titanium, stainless steel, glass, ceramics [13], and even purple sand [14]. Herein, a conventional process for making the MAIMs of PDMS as well as for fabricating the silicon master molds by photolithography and reactive ion etching (RIE) is introduced [15, 16]. Figure 1 shows the process flowchart (top and side view) for fabrication of the MAIMs, while the concrete steps are described as follows.

1. Put the 8-mm side length (100)-oriented silicon square wafers in sample boats which are then transferred into the oxidation chamber of an oxidation furnace (Wafer World Inc., Palm Beach County, FL, USA).
2. Close the door of the wafer-loaded oxidation furnace which is subsequently turned on in the thermal wet oxidation mode at 900 °C for 10 h to grow an oxide (SiO_2) layer of 1 μm depth on the surface of each wafer (Fig. 1a) (*see Note 1*).
3. Fix the oxide-layered silicon wafers on the sample chuck of a spin coater.
4. Deposit 100 μL of positive photoresist (AR-P 3540T) (*see Note 2*) at the center point of the upper surface of the silicon wafer using dynamic dispense at rotating rate of 500 rpm (*see Note 3*).
5. Disperse the photoresist to a layer of 1.4- μm thickness to cover the upper surface of the silicon wafer (Fig. 1b) at the rotating speed of 4000 rpm for 45 s with the acceleration/deceleration of 1000 rpm/s.
6. Temper the photoresist on the wafers at 95 °C for 25 min in a convection oven, and then cool them to room temperature.
7. Photolithographically pattern the photoresist film with a 6 \times 6 array of square masks each measuring 800 μm in side length with 120 μm side-to-side spacing (Fig. 1c, only the fraction of 3 \times 3 is shown), and the conventional photolithography process may be employed for patterning (*see Note 4*).
8. Etch the SiO_2 that are not covered by photoresist by isotropic reactive ion etching (RIE) to form an identical pattern to that of the photoresist on each wafer in a reactive ion etcher using the common RIE condition (Fig. 1c) (*see Note 5*).
9. Immerse the patterned wafers in 29 % (g/mL) KOH solution of in a petri dish to anisotropically etch the silicon bulk at 79 °C for about 300 min (*see Note 6*) when the octagonal

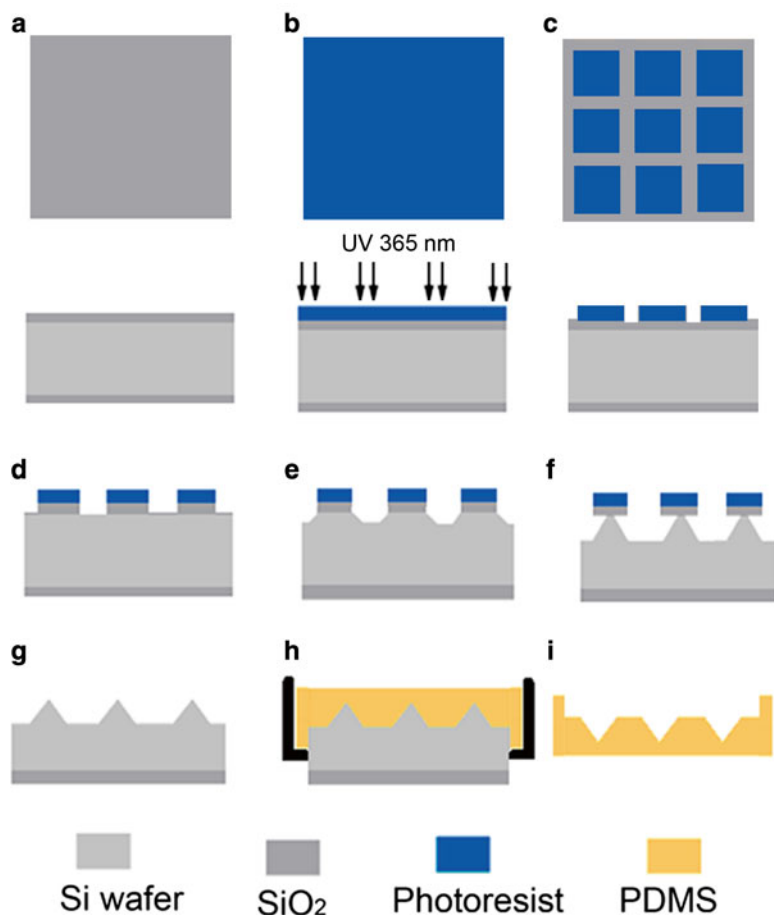

Fig. 1 Process flowchart showing the basic steps in the fabrication of the microneedle and its support chip (The *first row* is top views of a, b, and c, others are side views)

pyramids with a height of around 300 μm on each silicon wafer are engendered, while the masks of photoresist and oxide are just detached from the tips. And the silicon microneedle arrays are thus obtained and can be used as the master molds (Fig. 1g).

10. Wash three times the master molds firstly with acetone and then with pure water to completely remove the photoresist and solvent residue, and then dry them a cabinet dryer.
11. Fix the dry silicon master molds with microneedles upwards in the specially designed stainless steel cassettes (Fig. 1h).
12. Pour slowly an appropriate amount of the degassed Sylgard 184 (PDMS prepolymer solution) to fully cover each of the silicon microneedle arrays fixed in the cassette (Fig. 1h).
13. Cure thermally the prePDMS over the silicon master molds at 120 $^{\circ}\text{C}$ for 60 min in the incubator, allowing the prepolymer to polymerize forming the PDMS (see Note 7).

14. Peel off the PDMS structures from the master molds after they are cooled to room temperature, and thus the microneedle array inverse molds (MAIMs) made of PDMS are obtained (Fig. 1i).

3.2 Preparation of the Multifunctional Liposome-Constituted Microneedle Arrays (LiposoMAs)

The antigen-loaded multifunctional liposomes, such as those decorated with mannose derivative and lipid A, may be prepared by the procedure of emulsification-lyophilization (PEL) (*see* previous Chapter 42), and characterized according to refs. 11, 17–20. The microneedle arrays, which contain the antigen-loaded multifunctional liposomes in microneedles projecting from the base substrate, can be prepared by firstly filling the aqueous suspension of vaccine ingredients into the microholes of a MAIM and then drying to remove water. The whole process should be performed under aseptic conditions [12].

1. Pipette an appropriate volume (no more than that of the micro-tank of the MAIM) of the aqueous suspension of liposomes into the micro-tank above the micro-holes of the MAIMs.
2. Transfer the liposome-loaded MAIMs onto the sample shelf of a nitrogen-filled vacuum desiccator which contains anhydrous CaCl_2 and has a three-way valve connected to a vacuum pump and nitrogen gas source.
3. Lock the gas inlet valve of the desiccator and open the pump-connected valve.
4. Turn on the vacuum pump to pump out the gas in the desiccator until the bubbles in the microholes blast out.
5. Lock the pump-connected valve and turn off the pump.
6. Open the gas inlet valve to fill the desiccator with nitrogen gas until the vacuum is balanced.
7. Lock the gas inlet valve of the desiccator and disconnect the valve with the inert gas source.
8. Switch off the valve and open the desiccator.
9. Take out the MAIMs and collect the redundancy of liposome suspensions with a pipette for recycling use.
10. Pipette an appropriate volume (equal to the micro-tank of the MAIM) of aqueous solution of 10 % (w/v) sucrose and 20 % (w/v) PVPk₃₀ to fill the tank of the MAIM.
11. Put the vaccine-loaded MAIMs back into the desiccator and seal the desiccator filled with nitrogen gas.
12. Put the sample containing desiccator in dark for 6 h to remove 80 % of the total water in the sample (*see* note usually about 6–10 h).
13. Peel off carefully the microneedle arrays (LiposoMAs) from the MAIMs and put them in a dish filled with nitrogen gas, covered.

14. Put the LiposoMA-containing dish back into the desiccator for another 24 h to remove most water.
15. Seal the LiposoMA-containing dish and store it in the dark at 4 °C.

3.3 Characterization of the Multifunctional Liposome-Constituted Microneedle Arrays (LiposoMAs)

3.3.1 Test of Penetration Ability of LiposoMAs

The size, such as height, width, or diameter of individual microneedles can be estimated using a stereomicroscope (Leica or Zeiss) equipped with calibrated scales. Otherwise, these parameters can be calculated in a fluorescence microscope [12].

Since the LiposoMAs are designed for vaccination of mammals via oral cavity mucosa, the microneedles of LiposoMAs should be hard enough to pierce the upper layer of stratified squamous epithelia and can penetrate the oral mucosa. The porcine skin is used to test the hardness of microneedles since it is usually tougher than the skin of other mammals and much tougher than mucosal tissues [21].

1. Cut the depilated porcine ear skin into rectangle pieces with a size of no less than twofold length and width of the LiposoMAs.
2. Patch quickly a LiposoMA onto the skin in a dish with a force of approximately 5 N, and then remove it immediately.
3. Stain the inserted area of skin with trypan blue for 5 min.
4. Remove completely the stain solution on the skin surface and swabbed three times with PBS (pH 7.4).
5. Take the pictures of the inserted skin using a digital camera (Canon, Japan).

3.3.2 Dissolution Kinetics Analysis of LiposoMA

1. Dip the microneedles of a LiposoMA into PBS (pH 7.4) and immediately take it out.
2. Measure and snapshot in real time the remaining length of microneedles using a stereomicroscope until the microneedles vanish (usually within 1 min).
3. Plot the length (μm) of the remaining microneedles versus time (s) in a horizontal-vertical (x - y) coordinate.

3.4 Immunization with LiposoMA Vaccine at Oral Cavity Mucosa

The experimental animals, such as mice, rats, rabbits, and dogs, can be used as a vaccination model. Since a LiposoMA has usually a size of more than $0.5 \times 0.5 \times 0.25 \text{ cm}^3$, the larger an oral cavity the animal model has, the easier the immunization with the vaccine via oral mucosa will be. Thus, rabbits and dogs are preferred vaccination models. However, mice are here used as the model for description of the vaccination protocol. And other protocols described in the following are all based on mouse model. When the prepared LiposoMAs to be administered have a dimensional size much larger than that of the oral cavity of the animal model, such

as a mouse, the LiposoMA can be cut into smaller pieces to give one by one at oral mucosa [12].

1. Restrain the unanesthetized mouse in a mouse fastener with its head out but fixed in position.
2. Open completely the animal mouth using an appropriate apparatus, such as a pair of hemostatic forceps, to expose fully its oral cavity to the outside.
3. Carefully nip the opposite sides of a LiposoMA basement between the tips of tweezers with microneedles forwards.
4. Patch the LiposoMA rapidly onto either one site of the vestibule mucosa surfaces (*see Note 8*) or the surfaces of tongue.
5. Keep the mouse mouth tightly closed for more than 30 s.
6. Release the mouse into the cage other than the one where the unvaccinated mice constrained.
7. Repeat **steps 1–6** to vaccinate other mice.

3.5 Efficacy Assay for Oral Mucosal Vaccination of LiposoMAs

3.5.1 Blood Collection

Collection of blood from treated mice is necessary to obtain the data on a wide range of parameters, such as immunoglobulins, interferons, interleukins, and other cytokines, to evaluate humoral and cellular immune responses to vaccines. Usually, for a mouse with a bodyweight of 30 g, on a single occasion the nonterminal blood collection, followed by immediate fluid replacement, results in about 0.5 mL blood, and the collection may be repeated after 3–4 weeks (*see Note 9*). In general, blood sample is withdrawn from venous, arterial blood vessels or heart chambers. Due to the requirement of repeated collection and a relatively large volume for each collection, the procedure for orbital sinus blood sample collection is described here [22].

1. Anesthetize mice by i.p. injection of 600 $\mu\text{g}/\text{mL}$ sodium pentobarbital in saline at the dose of 60 $\mu\text{g}/\text{g}$ bodyweight.
2. Seize mouse by the scruff with thumb and forefinger of the nondominant hand and pull taut the skin around the eye (*see Note 10*).
3. Insert a capillary into the medial canthus of the eye (30° angle to the nose) to puncture the tissue and enter the plexus/sinus.
4. Once blood comes through the capillary, collect the required volume of blood in a tube.
5. Gently remove the capillary tube and wipe the eye with sterile cotton, applying gentle finger pressure to stop bleeding.
6. Allow the blood to stand at room temperature for 20 min and then centrifuge for 10 min at $10,000\times g$.
7. Collect the supernatant serum in a tube and store it at -20°C until further assay.

3.5.2 Collection of External Secretions

The advantages of immunization of LiposoMAs via oral cavity mucosa over via the skin include several aspects as follows [12]. It can be more effective in inducing extensive, especially mucosal, immunoresponses against antigenic substances; it is convenient and has good compliance and needs no specially trained medical personnel; it remarkably lowers the standards of hardness for microneedles and will greatly widen the scope of materials and methods that can be used for producing biodegradable microneedle vaccines; also, it can significantly enhance immunization efficiency due to insertion of vaccines into the epithelia of mucosa and, thus, no ingredient loss with saliva and swallow. Samples of blood, saliva, vaginal and intestinal flush should be collected 3 weeks after final immunization in treated mammals. For sample collection, the treated mice are deprived of food, but not water, overnight and anesthetized by i.p. injection of chloral hydrate.

3.5.3 Collection of Saliva

Saliva is the most commonly used fluid for measurements of humoral mucosal responses in mice and is often collected from mice after they receive chemical stimulants, such as carbachol (carbamyl choline chloride) and pilocarpine-HCl (Sigma). Carbachol (acetylcholine agonist) can rapidly initiate a great, but short-lived, increase in saliva flow and thus facilitates an easy and quick collection of saliva without the anesthetization of mice [23].

1. Give each mouse by i.p. injection 10 $\mu\text{g}/\text{mL}$ carbachol or 0.5 mg/mL pilocarpine in PBS at the doses of 0.1 or 5 $\mu\text{g}/\text{g}$ bodyweight, respectively (*see Note 11*). And then manually restrain the unanesthetized mouse with its head unmovable.
2. When mice drool (*see Note 12*), quickly aspirate the resulting saliva with pipette (avoiding any gingival damage), and rapidly pipet it into a 0.5-mL tube placed on ice (*see Note 13*).
3. Centrifuged the collected saliva at $800 \times g$ for 5 min to remove potential bacteria and particles.
4. Transfer the supernatant to properly labeled tubes add 1 μL of $100 \times$ protease inhibitor cocktail (Sigma) per 100 μL sample.
5. Store the saliva-containing vials at -20°C until further assay.

3.5.4 Collection of Genital Secretions

Genital secretions are also used to evaluate the humoral immune responses not only to local immunizations but also to the vaccinations at other mucosal sites. Although vaginal secretions are very easy to collect, the amount of recovered sample is rather small. Collection of female genital tract secretions can be performed by vaginal lavage or by use of filter wicks. The lavage technique is rather simple and involves only the rinsing of the vaginal cavity with saline or PBS [24].

1. Restrain by hand the unanesthetized mouse with caudal end upwards.
2. Gently inject 100 μL of saline or PBS into the mouse vagina with a pipette and aspire-release five times.

3. Pipette the recovered fluid (about 80 μL) into a 0.5-mL test tube.
4. Repeat **steps 2** and **3** to collect about 180 μL of vaginal flush (*see Note 14*).
5. Add 2 μL of a 100 \times protease inhibitor cocktail and centrifuge the lavage at 800 $\times g$ for 5 min and at 4 $^{\circ}\text{C}$.
6. Collect the supernatant and store at -80°C until further assay.

3.5.5 Collection of Bronchoalveolar Lung Secretions

Nasal and bronchoalveolar lung (BAL) secretions can only, in practice, be collected in postmortem mice, and thus sequential collection of the secretions is not feasible [24].

1. Euthanize mice by i.p. injection of an overdose of pentobarbital (e.g., 0.1 mg/g bodyweight).
2. Place the mouse on its back, expand the legs outwards, and immobilize them with pins. Make an incision from the chest to the maxilla and strip the skin. Make a midline incision over the anterior aspect of the trachea slightly superior to the thoracic inlet.
3. Clamp trachea off at the level of thoracic inlet.
4. Insert a blunt animal-feeding needle attached to a 1-mL syringe into the tracheal lumen and secure it in place with surgical thread.
5. Carefully inject 500 μL of PBS into the lung through tracheal lumen and then aspirate the fluid. Repeat this procedure five times.
6. Aspirate the lavage into a 1-mL tube and centrifuge at 800 $\times g$ for 5 min at 4 $^{\circ}\text{C}$ to pellet the cells and contaminating bacteria.
7. Collect the supernatant, add 5 μL of a 100 \times protease inhibitor cocktail, and then freeze at -80°C until assay.

3.5.6 Collection of Nasal Secretions

1. Place the mouse on its back with the head inclined and the nose above a 0.5-mL tube.
2. Insert a blunt feeding needle attached to a syringe into the cephalic tracheal lumen, and slowly inject 200 μL PBS, which will drip through the nose into the collection tube and be re-injected and collected twice (*see Note 15*).
3. Centrifuge the lavage at 800 $\times g$ for 5 min at 4 $^{\circ}\text{C}$.
4. Collect the supernatant, add 5 μL of a 100 \times protease inhibitor cocktail, and then freeze at -80°C until assay.

3.5.7 Intestinal Secretions

Intestinal secretions are important samples for testing immune responses against mucosally administered vaccine and are usually obtained from mice by intestinal lavage and extraction of fecal samples (*see Note 16*).

Intestinal Flushes

Mouse intestinal flushes are usually performed at the termination of experiments and can be obtained as follows.

1. Euthanize the mouse that has been fasted overnight by i.p. injection of pentobarbital with an over dose of 0.1 mg/g bodyweight.
2. Open the abdomen of the euthanized mouse.
3. Excise the small intestine at the pylorus and cecum and place it into a 60-mm diameter petri dish.
4. Cut the intestine in two approximately equal segments.
5. Flush each intestine segment twice as follows. Gently inject 250 μ L of PBS with 2.5 μ L of 100 \times protease inhibitors cocktail through each section with a pipette and collect the flush into a 1-mL microcentrifuge vial.
6. Vortex vigorously the intestinal flush-containing vial for 3 min, and then centrifuge at 16,000 $\times g$ at 4 $^{\circ}$ C for 20 min to remove the solid materials.
7. Collect the supernatant, and store at -80° C until further assay.

Fecal Samples

The fecal sample for obtaining intestinal secretions is painless to mice and relatively easy to perform [25].

1. Place each mouse in a separate cage for up to 30 min and collect feces free of urine.
2. Take 0.2 g of the collected feces pellets in a 2-mL centrifuge tube.
3. Add into the sample tube 1 mL of PBS-0.01 % sodium azide with 1 % (v/v) 100 \times protease inhibitor cocktail (Sigma) and 1 % (w/v) BSA (bovine serum albumin).
4. Place the tubes on a platform head and vortex them for 20 min to suspend all materials.
5. Filtrate the suspension with 300-mesh strainer (with pore size of 50 μ m).
6. Collect the filtrate and centrifuge at 16,000 $\times g$ at 4 $^{\circ}$ C for 20 min to remove the solids.
7. Freeze the supernatant at -80° C until further assay.

3.5.8 Isolation of Splenocytes from Mouse Spleen

While proliferation profile of the immune cells from treated mice indicates the level of the immune responses to a vaccine, the cell types and their fractions in lymphoid tissues, such as spleen, lymph nodes, and thymus, show the pathways along which the immune responses elicited by a vaccine have progressed and developed. Therefore, isolation and assay of immune cells from lymphoid tissues are necessary for evaluation of the vaccine efficacy. Here isolation of splenocytes from mouse spleen is described, and the cells from other lymphoid tissues can be isolated likewise. Commonly,

cell isolation should be performed with aseptic manipulation in a sterile cabinet or under a sterile condition.

1. Place a cell strainer (200-mesh with pore size of 70 μm) in the petri dish.
2. Isolation of the spleen from the abdomen-anatomically-opened mouse that has been euthanized (*see* above Subheading 3.5.5), transfer the spleen and 2 mL PBS directly into the cell strainer.
3. Grind the spleen with the plunger of a 2-mL syringe by using grinding circular movements to release the splenocytes into the petri dish (*see* **Note 17**).
4. Periodically, draw up liquid from outside the strainer with a pipette, and wash out the cells from within the strainer. Continue to mash the spleen until all that remains is the white connective tissue of the outer membrane.
5. Transfer the homogenized cell suspension into a 5-mL tube. Wash out the petri dish with 1 mL PBS twice to maximize recovery of splenocytes.
6. Centrifuge at $800 \times g$ for 5 min at room temperature and discard the supernatant by decanting (*see* **Note 18**).
7. Resuspend fully the cell pellet in 1 mL red cell lysing solution and leave for just 2 min at room temperature.
8. Dilute immediately the cell suspension with 4 mL PBS, and centrifuge at $800 \times g$ for 5 min.
9. Discard the supernatant and resuspend the cells completely in a full volume of PBS. Pellet by centrifuge and wash twice with PBS.
10. Resuspend cells in desired medium (e.g., RPMI-1640) to a final known volume.
11. Count live cells using a hemacytometer under light microscope (*see* **Note 19**).

3.5.9 Isolation of Superficial Lymphoid nodes

When lymphocytes from lymphoid nodes are isolated for culture, aseptic conditions should be maintained throughout the procedures [25].

1. Anesthetize or euthanize the mouse.
2. Put the mouse on its side and localize the region of the superficial lymph node (e.g., inguinal or brachial lymphoid node) to be harvested.
3. Apply chlorhexidine, or another disinfectant, to that region.
4. Make a tiny incision (about 5 mm) with scissors on the skin over the lymph node.
5. Stretch the incision with 2 forceps and find the lymph node, which may appear grayish or darker than the surrounding fat.

6. Pinch the fascia (thin membrane covering the fat and tissue) on top of the lymph node with one forceps and pull lightly without breaking the surrounding tissue.
7. Clamp the second forceps underneath the lymph node. Break the fascia with the first forceps and remove the lymph node.
8. Place the lymph node in a 5- or 10-mL tube containing isotonic solution. The lymph node should sink to the bottom of the tube, and this simple test validate that a lymph node but not fat tissue has been extracted.

The obtained lymph nodes can be further subjected lymphocytes isolation or histological section for immunological assay.

3.5.10 Immunological Assays

The antigen-specific antibodies produced in treated mice can be assayed using the conventional indirect ELISA method in a microplate reader (μ Quant™, BioTek Instruments, Inc., Vermont, USA) [22]. The cell proliferation can be tested by MTT method. The cell types and their fractions can be quantitatively assayed by flow cytometry and, otherwise, can be qualitatively assayed using a fluorescence microscope or a confocal laser scanning microscope [25].

4 Notes

1. In wet thermal oxidation, the oxygen is led through a bubbler vessel filled with heated water (about 95 °C), so that in addition to oxygen water is present in the quartz tube as steam. The oxidation is given by: $\text{Si} + 2\text{H}_2\text{O} \rightarrow \text{SiO}_2 + 2\text{H}_2$. This process is done at 900–1000 °C. The growth rate of wet oxidation of silicon is about 100 nm per hour.
2. Positive photoresists as produced by Allresist, e.g., ARP 3100, 3200, 3540, are composed of a combination of film forming agents such as for example cresol novolak resins and light sensitive components such as for example naphthoquinone diazide, which are dissolved in solvents such as for example methoxy propyl acetate (equivalent to PGMEA). The addition of the light sensitive component to the alkali soluble novolak leads to a reduced alkali solubility. After exposure at 308–450 nm (UV range) using an exposure mask, the light sensitive component is converted into the respective indene carbonic acid derivative which enhances the alkali solubility of positive resists by a factor of 100. After development, only those areas which are protected by the mask remain, while exposed areas are detached. The refractive index of novolac based resists is in a range of 1.60. After development, only areas protected by the mask remain while the exposed areas are dissolved.

Photoresists provide an excellent protection against etch media with pH values between 0 and 13.

3. The unexposed photoresist should be handled under yellow safe light.
4. A conventional photolithography process for the patterning is as follows: (1) Expose the photoresist film with the UV light at 365 nm for 35 s (the exposure dose of 120 mJ/cm²) using an ABM lithography machine; (2) Pipette 50 μ L of the developer AR300-40 over the photoresist for puddle development for 60 s at 22 °C; (3) Rinse the wafers immediately after development with deionized water for 60 s to completely remove all residual developer; (4) Dry the wafers at 115 °C for 25 min in a convection oven.
5. The common RIE condition is as follows: the pressure of 2.8 Torr, the CF₄, He, and CHF₃ gas flow of 90, 170, and 30 SCCM (standard cubic centimeter per minute) respectively, gas spacing of 1.35 cm, RIE interval of 30 s, power of 900 W.
6. Silicon microneedles are fabricated using 29 % potassium hydroxide (KOH) at a temperature of 79 °C [15]. The etch rate in [100] direction was 0.9 (\pm 0.02) μ m/min. The process starts with the formation of {111}-silicon crystal planes. After a certain etch depth, {111}-crystal planes are etched away by faster etching planes (etch rate >2 μ m/min), with an octagon at the base. The needle shape is formed when the eight high index crystal planes, revealed as {312} planes, come together on top of the frustum generating a sharp needle tip. At this stage, the remaining mask will become detached. The aspect ratio of needle height to bottom diameter of high index crystal planes is 3:2.
7. SYLGARD 184 is used with 10:1 mixing ratio of base to curing agent.
8. The vestibule mucosa surfaces include the interior surfaces of lips and cheeks.
9. The estimated blood volume in adult animals is 0.55–0.70 mL/10 g body weight. All nonterminal blood collection without replacement of fluids is limited up to 10 % of total circulating blood volume in healthy, normal, adult animals on a single occasion and collection may be repeated after 3–4 weeks. If blood collection volume exceeds more than 10 % of total blood volume, fluid replacement may be required. Lactated Ringer's solution (LRS) is recommended as the best fluid replacement by National Institutes of Health (NIH). If the volume of blood collection exceeds more than 30 % of the total circulatory blood volume, adequate care should be taken so that the animal does not suffer from hypovolemia.
10. Even a minor mistake will cause damage to the eyes, and two weeks should be allowed between two bleedings. Adverse

effects reported from this method are around 1–2 % which includes hematoma, corneal ulceration, keratitis, pannus formation, rupture of the globe, damage of the optic nerve and other intraorbital structures, and necrotic dacryoadenitis of the harderian gland.

11. For a mouse with a bodyweight of 20 g, the injection volume is 0.2 mL of 10 $\mu\text{g}/\text{mL}$ carbachol or 0.5 mg/mL pilocarpine in PBS.
12. After receiving carbachol or pilocarpine, usually mice will drool in less than 1 min.
13. Usually, up to 500 μL of saliva can be obtained from one mouse in 10 min. However, under most cases it is difficult to pool more than 200 μL of saliva secretion in one mouse, and if necessary, collection of saliva from several mice in the same group gives one sample for immunological assay.
14. To obtain a larger sample of genital secretions, repeating the same procedure 6 h later is suggested.
15. To avoid contamination with saliva, remove the mandible and gently flush the nasal cavity from the posterior opening of the nose with ~ 200 μL of PBS and collect nasal washes from the anterior openings of the nose. Care must be taken to avoid contamination of the nasal lavages with blood.
16. If results are to be accurate, collected intestinal samples must be processed and stored properly. The addition of protease inhibitors is essential for measurement of total- and Ag-specific antibodies, and freeze-drying is recommended for samples stored longer than 6 months. Alternatively, air dried samples proved adequate for antibody measurement and have the advantage of not requiring refrigeration.
17. If desired, score the outer membrane of the spleen with a clean scalpel before mashing it, but take care to avoid cutting through the strainer mesh.
18. The resulting cell pellet should be red in color. The supernatant may appear cloudy, due to smaller particles that cannot be centrifuged at this setting.
19. If proceeding straight to staining for flow cytometry, distribute the cells equally between sample tubes. Otherwise, resuspend the cells in a few milliliters of wash buffer and use the same day.

Acknowledgements

This work was supported by the Faculty S&R Project Startup Fund of Hefei University of Technology (HUT, grant number XJ201407), and also by the Fundamental Research Funds for the Central Universities for HUT. The authors heartily thank Engineer Wulin Zhu from the Precision Machinery and Instrumentation

Department of University of Science and Technology of China for his guidance in the description of the preparation of the PDMS MAIMs.. The authors heartily thank Engineer Wulin Zhu from the Precision Machinery and Instrumentation Department of University of Science and Technology of China for his guidance in the description of the preparation of the PDMS MAIMs.

References

1. Lycke N (2012) Recent progress in mucosal vaccine development: potential and limitations. *Nat Rev Immunol* 12(8):592–605. doi:[10.1038/nri3251](https://doi.org/10.1038/nri3251), nri3251 [pii]
2. Barouch DH (2013) The quest for an HIV-1 vaccine—moving forward. *N Engl J Med* 369(22):2073–2076
3. Kim SH, Lee KY, Jang YS (2012) Mucosal immune system and M cell-targeting strategies for oral mucosal vaccination. *Immune Netw* 12(5):165–175. doi:[10.4110/in.2012.12.5.165](https://doi.org/10.4110/in.2012.12.5.165)
4. Kweon MN (2011) Sublingual mucosa: a new vaccination route for systemic and mucosal immunity. *Cytokine* 54(1):1–5. doi:[10.1016/j.cyto.2010.12.014](https://doi.org/10.1016/j.cyto.2010.12.014), S1043-4666(10)00797-0 [pii]
5. Upadhyay J, Upadhyay RB, Agrawal P, Jaitley S, Shekhar R (2013) Langerhans cells and their role in oral mucosal diseases. *N Am J Med Sci* 5(9):505–514. doi:[10.4103/1947-2714.118923](https://doi.org/10.4103/1947-2714.118923), NAJMS-5-505 [pii]
6. Giannola LI, Sutera FM, De Caro V (2013) Physical methods to promote drug delivery on mucosal tissues of the oral cavity. *Expert Opin Drug Deliv* 10(10):1449–1462. doi:[10.1517/17425247.2013.809061](https://doi.org/10.1517/17425247.2013.809061)
7. Baudner BC, O’Hagan DT (2010) Bioadhesive delivery systems for mucosal vaccine delivery. *J Drug Target* 18(10):752–770. doi:[10.3109/1061186X.2010.529143](https://doi.org/10.3109/1061186X.2010.529143)
8. Bakhru SH, Furtado S, Morello AP, Mathiowitz E (2013) Oral delivery of proteins by biodegradable nanoparticles. *Adv Drug Deliv Rev* 65(6):811–821. doi:[10.1016/j.addr.2013.04.006](https://doi.org/10.1016/j.addr.2013.04.006), S0169-409X(13)00066-5 [pii]
9. Ensign LM, Tang BC, Wang YY, Tse TA, Hoen T, Cone R, Hanes J (2012) Mucus-penetrating nanoparticles for vaginal drug delivery protect against herpes simplex virus. *Sci Transl Med* 4(138):138ra179. doi:[10.1126/scitranslmed.3003453](https://doi.org/10.1126/scitranslmed.3003453), 4/138/138ra79 [pii]
10. Kirtane AR, Kalscheuer SM, Panyam J (2013) Exploiting nanotechnology to overcome tumor drug resistance: challenges and opportunities. *Adv Drug Deliv Rev* 65(13–14):1731–1747. doi:[10.1016/j.addr.2013.09.001](https://doi.org/10.1016/j.addr.2013.09.001), S0169-409X(13)00196-8 [pii]
11. Wang N, Wang T, Zhang M, Chen R, Niu R, Deng Y (2014) Mannose derivative and lipid A dually decorated cationic liposomes as an effective cold chain free oral mucosal vaccine adjuvant-delivery system. *Eur J Pharm Biopharm* 88:194–206. doi:[10.1016/j.ejpb.2014.04.007](https://doi.org/10.1016/j.ejpb.2014.04.007), S0939-6411(14)00124-6 [pii]
12. Wang T, Zhen Y, Ma X, Wei B, Li S, Wang N (2015) Mannosylated and lipid A-incorporating cationic liposomes constituting microneedle arrays as an effective oral mucosal HBV vaccine applicable in the controlled temperature chain. *Colloids Surf B Biointerfaces* 126:520–530. doi:[10.1016/j.colsurfb.2015.01.005](https://doi.org/10.1016/j.colsurfb.2015.01.005)
13. Indermun S, Luttge R, Choonara YE, Kumar P, du Toit LC, Modi G, Pillay V (2014) Current advances in the fabrication of microneedles for transdermal delivery. *J Control Release* 185:130–138. doi:[10.1016/j.jconrel.2014.04.052](https://doi.org/10.1016/j.jconrel.2014.04.052)
14. Yang S, Feng Y, Zhang L, Chen N, Yuan W, Jin T (2012) A scalable fabrication process of polymer microneedles. *Int J Nanomedicine* 7:1415–1422. doi:[10.2147/IJN.S28511](https://doi.org/10.2147/IJN.S28511)
15. Wilke N, Morrissey A (2007) Silicon microneedle formation using modified mask designs based on convex corner undercut. *J Micromech Microeng* 17(2):238–244. doi:[10.1088/0960-1317/17/2/008](https://doi.org/10.1088/0960-1317/17/2/008)
16. Wilke N, Mulcahy A, Ye SR, Morrissey A (2005) Process optimization and characterization of silicon microneedles fabricated by wet etch technology. *Microelectron J* 36(7):650–656. doi:[10.1016/j.mejo.2005.04.044](https://doi.org/10.1016/j.mejo.2005.04.044)
17. Wang T, Wang N, Sun W, Li T (2011) Preparation of submicron liposomes exhibiting efficient entrapment of drugs by freeze-drying water-in-oil emulsions. *Chem Phys Lipids* 164(2):151–157. doi:[10.1016/j.chemphyslip.2010.12.005](https://doi.org/10.1016/j.chemphyslip.2010.12.005), S0009-3084(10)00391-9 [pii]
18. Wang T, Wang N, Song H, Xi X, Wang J, Hao A, Li T (2011) Preparation of an anhydrous reverse micelle delivery system to enhance oral bioavailability and anti-diabetic efficacy of

- berberine. *Eur J Pharm Sci* 44(1–2):127–135. doi:[10.1016/j.ejps.2011.06.015](https://doi.org/10.1016/j.ejps.2011.06.015), S0928-0987(11)00218-1 [pii]
19. Wang T, Wang N, Jin X, Zhang K, Li T (2009) A novel procedure for preparation of submicron liposomes-lyophilization of oil-in-water emulsions. *J Liposome Res* 19(3):231–240. doi:[10.1080/08982100902788390](https://doi.org/10.1080/08982100902788390), 909232172 [pii]
 20. Wang T, Deng Y, Geng Y, Gao Z, Zou J, Wang Z (2006) Preparation of submicron unilamellar liposomes by freeze-drying double emulsions. *Biochim Biophys Acta* 1758(2):222–231. doi:[10.1016/j.bbamem.2006.01.023](https://doi.org/10.1016/j.bbamem.2006.01.023), S0005-2736(06)00033-2 [pii]
 21. Guo L, Chen J, Qiu Y, Zhang S, Xu B, Gao Y (2013) Enhanced transcutaneous immunization via dissolving microneedle array loaded with liposome encapsulated antigen and adjuvant. *Int J Pharm* 447(1–2):22–30. doi:[10.1016/j.ijpharm.2013.02.006](https://doi.org/10.1016/j.ijpharm.2013.02.006), S0378-5173(13)00140-3 [pii]
 22. Wang N, Wang T, Zhang M, Chen R, Deng Y (2014) Using procedure of emulsification-lyophilization to form lipid A-incorporating cochleates as an effective oral mucosal vaccine adjuvant-delivery system (VADS). *Int J Pharm* 468(1–2):39–49. doi:[10.1016/j.ijpharm.2014.04.002](https://doi.org/10.1016/j.ijpharm.2014.04.002), S0378-5173(14)00230-0 [pii]
 23. Nagler RM, Baum BJ, Fox PC (1993) Acute effects of X irradiation on the function of rat salivary glands. *Radiat Res* 136(1):42–47
 24. Moldoveanu Z, Fujihashi K (2005) Collection and processing of external secretions and tissues of mouse origin. In: Lamm ME, McGhee JR, Bienenstock J, Mayer L, Strober W, Mestecky J (eds) *Mucosal immunology*, 3rd edn. Elsevier, Amsterdam, pp 1841–1852
 25. Wang T, Zhen Y, Ma X, Wei B, Wang N (2015) Phospholipid bilayer-coated aluminum nanoparticles as an effective vaccine adjuvant-delivery system. *ACS Appl Mater Interfaces* 7(12):6391–6396. doi:[10.1021/acsami.5b00348](https://doi.org/10.1021/acsami.5b00348)

Preparation and Characterization of PLGA Encapsulated Protective Antigen Domain 4 Nanoformulation

Manish Manish, Rakesh Bhatnagar, and Samer Singh

1 Introduction

PLGA based nanoparticle vaccine formulations have been extensively explored for the controlled antigen release and achieve single dose immunization schedule [1–4]. However, the major challenges encountered in such endeavors are the exposure of antigen to aqueous/organic phase interface during particle formulation process and the acidic pH environment arising as a result of the PLGA degradation that can alter the native conformation of antigen and consequently affect the quality of immune response [5–7]. Hence, the search for an immunogenic moiety which can maintain the native structure even in such harsh environments remains a major challenge for designing an effective PLGA based vaccine.

Protective antigen (PA) of *Bacillus anthracis* is a dominant antigen that elicits protective immunity. The recombinant protective antigen (PA) domain 4 (PAD4) molecule has been shown to maintain its native structural conformation at acidic conditions [8]. The crystal structure of PAD4 alone (pdb id: 3INO) shows conformation similar to that of domain 4 in native PA molecule (pdb id: 1ACC). Domain 4 of the PA molecule (PAD4) is responsible for the binding of PA molecule with the host anthrax toxin receptors—tumor endothelial marker 8 (TEM-8) and capillary morphogenesis gene 2 (CMG-2) [9]. Furthermore, PAD4 has been extensively studied as a potential vaccine candidate against anthrax [10].

We evaluated the recombinant PAD4 for the suitability in PLGA based nanoformulation and assessed the enhancement in protective immune response generated by this PLGA encapsulated PAD4 nanoformulation (PAD4-NP) [11]. The recombinant PAD4 was purified from PAD4 expressing *Escherichia coli* cell using Ni-NTA affinity chromatography and employing urea

denaturation lysis followed by on-column renaturation. Water/oil/water (w/o/w) solvent evaporation method was employed for the preparation of PAD4-NP (Fig. 1). W/o/w solvent evaporation method is a widely used method for ease of preparation without the need of high end equipment. In this method, a prospective antigen is first dissolved in aqueous environment or phase making it suitable for encapsulation of proteins. This aqueous phase constitutes “internal aqueous phase” in the final formulation. It is dispersed in a PLGA polymer containing “organic phase” followed by the dispersion of this PLGA (organic phase) encapsulated protein antigen containing aqueous internal phase in another aqueous phase termed as “external aqueous phase” that normally contains a surfactant such as poly vinyl alcohol (PVA). Later, the evaporation of volatile organic solvent employed as organic phase is effected causing the hardening of PLGA matrices (hence the term “solvent evaporation”). This method has been extensively studied by various investigators, hence the formulation parameters which can influence the particle characteristics are known in greater detail [12, 13]. However, inability to precisely control batch to batch variation in the properties of nanoparticles produced along with

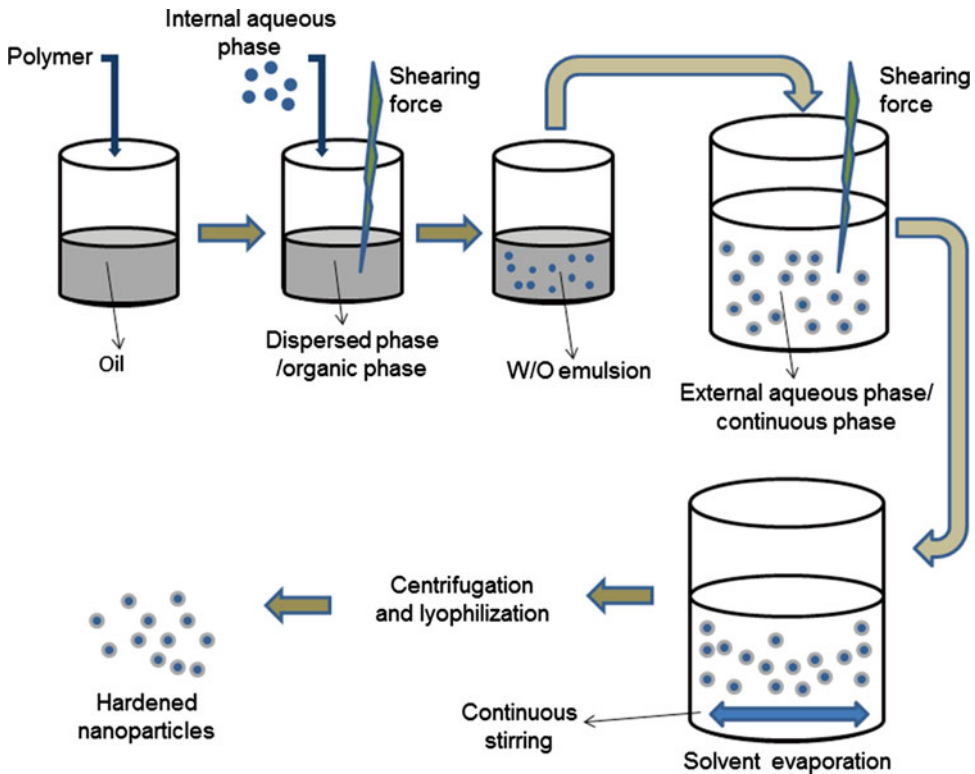

Fig. 1 A schematic diagram of w/o/w solvent evaporation method showing steps employed for the formulation of recombinant protective antigen domain 4 nanoparticles (PAD4-NP)

their broader size distribution, are few major drawbacks of this method as compared to other methods [14].

Recombinant proteins frequently aggregate/precipitate at higher concentrations such as 10 mg/ml; however, PAD4 remains soluble at higher concentrations [15]. This increased solubility of PAD4 combined with its stability at low pH conditions enabled us to design a PLGA based nanoparticle formulation against anthrax. Immunization efficacy of PLGA based vaccine formulation primarily depends on the size and the lactide–glycolide composition [1]. These properties can influence the antigen release and phagocytosis. However, there is a complex relationship between the particle size, polymer composition, antigen release, and eventually immunogenicity. Antigen release kinetics cannot be accurately predicted with polymer composition and even by knowing antigen release kinetics we still cannot accurately predict the immune response. As of yet our understanding is not clear in these intriguing concepts. The only way to design these kinds of vaccines is by performing properly controlled experiments involving recombinant purified protein, PLGA particle formulation, studying particle characteristics, and evaluation of the immunization potential of such nanoformulations encapsulating potential antigens in animal models. In this chapter we touch on these methodological aspects of PLGA based vaccine design.

2 Materials

2.1 *Materials Required for Recombinant PAD4 Purification*

1. Recombinant PAD4 expression plasmid construct: The construct used in the current work has been described in detail by Gorantala et al. [16]. Briefly, it has a gene encoding for PAD4 with extra six histidine residues at the amino terminus as an affinity purification tag, cloned under isopropyl β -D-1-thiogalactopyranoside (IPTG) inducible promoter in pET-28a expression vector. This vector system has kanamycin as an antibiotic selection marker.
2. Kanamycin stock solution: Prepare 50 mg/ml stock solution in double distilled water and sterilize by filtration through 0.22 μ m filter. Store it at -20°C . Use 1 ml of this stock solution for 1 L of Luria–Bertani (LB) broth.
3. LB culture medium: Dissolve 25 g of LB powder (Difco Laboratories, Becton Dickinson, USA) in 1 L double distilled water. Sterilize the media by autoclaving at 121°C and 15 lb/sq in pressure for 20 min.
4. Ni-NTA resin: Use 4 ml of Ni-NTA solution (G-Bioscience Inc.) or 2 ml of Ni-NTA slurry for isolating and purifying recombinant PAD4 from bacterial culture obtained from 1 L of shake flask culture. The Ni-NTA resin is supplied as 50 %

slurry in 20 % ethanol. Transfer the slurry in propylene column and equilibrate with lysis buffer (see below) before use.

5. 1 M isopropyl β -D-1-thiogalactopyranoside (IPTG): Dissolve 238 mg of IPTG (MP Biomedicals Inc.) in 1 ml of deionized water. Filter-sterilize it and store at -20°C . Use 1 ml of 1 M IPTG solution to induce 1 L of *E. coli* culture.
6. Denaturing lysis buffer: Prepare the 1 M stock solution of NaH_2PO_4 , 1 M stock solution of Na_2HPO_4 and 5 M stock solution of NaCl and sterilize the solutions by autoclaving at 121°C and 15 lb/sq in pressure for 20 min. Mix 68.4 ml of 1 M stock solution of Na_2HPO_4 , 31.6 ml of 1 M stock solution of NaH_2PO_4 , 60 ml of 5 M NaCl, and 480 g of urea and make up the final volume to 1 L by adding sterile deionized water to prepare the “lysis buffer” containing 8 M urea, 0.1 M phosphate buffer, 300 mM NaCl, pH 7.2. Keep the lysis buffer solution at room temperature and always prepare fresh just before use.
7. Renaturation buffers: Prepare step gradient of urea from 8 M to 0 M (i.e., 8, 7, 6, 5, 4, 3, 2, 1, 0 M urea) in 0.1 M phosphate buffer, 300 mM NaCl, pH 7.2. The composition of 8 M urea renaturation buffer is same as the “lysis buffer” described above. To prepare it follow the procedure described above. The 0 M renaturation buffer (0.1 M phosphate buffer, 300 mM NaCl, pH 7.2) is prepared by omitting Urea in the lysis buffer (i.e., 68.4 ml of 1 M stock solution of Na_2HPO_4 + 31.6 ml of 1 M stock solution of NaH_2PO_4 + 60 ml of 5 M NaCl and make up the final volume to 1 L by adding sterile deionized water). The renaturation buffer step gradients are now prepared by proportionately mixing the 8 M and 0 M renaturation buffers (e.g., to prepare 16 ml of 7 M renaturation buffer mix 14 ml of 8 M renaturation buffer and 2 ml of 0 M renaturation buffer).
8. Wash buffers: A (50 mM imidazole, 300 mM NaCl, 0.1 M phosphate buffer, pH 7.4) and B (100 mM imidazole, 300 mM NaCl, 0.1 M phosphate buffer, pH 7.4). Wash buffer A prepared by mixing 77.4 ml of 1 M stock solution of Na_2HPO_4 , 22.6 ml of 1 M stock solution of NaH_2PO_4 , 60 ml of 5 M NaCl, and 3.4 g of imidazole and the final volume is made up to 1 L. Wash buffer B prepared by mixing 77.4 ml 1 M stock solution of Na_2HPO_4 , 22.6 ml of 1 M stock solution of NaH_2PO_4 , 60 ml of 5 M NaCl, and 6.8 g of imidazole and making up the final volume to 1 L.
9. Elution buffer (300 mM imidazole, 300 mM NaCl, 0.1 M phosphate buffer, pH 7.4): It is prepared by mixing 77.4 ml of 1 M stock solution of Na_2HPO_4 , 22.6 ml of 1 M stock solution of NaH_2PO_4 , 60 ml of 5 M NaCl, and 20.4 g of imidazole and making up the final volume to 1 L.

2.2 Materials Required for PLGA Particle Formulation

1. PLGA (Sigma-Aldrich Inc.): lactide–glycolide ratio 52:48, inherent viscosity=0.61 dL/g, end groups deactivated with lauryl alcohol (*see Note 1*).
2. Polyvinyl alcohol (PVA, 87–89 % hydrolyzed, average molecular weight 31,000–50,000, Sigma-Aldrich Inc.): Prepare 1 % w/v PVA in sterile deionized water to use as external aqueous phase. To dissolve the PVA, boil the water and immediately add PVA with vigorous stirring. Cover the beaker with aluminum foil. After 10 min slow down the stirrer and continue the slow stirring for 2 h.
3. Dichloromethane (DCM): Biotech grade 99.9 % pure in sure/seal glass bottles (Sigma-Aldrich Inc.).

2.3 Materials Required for Determination of Encapsulation Efficiency

1. Acetonitrile (CHROMASOLV® gradient grade, for HPLC, ≥99.9 %, Sigma-Aldrich Inc.)
2. Sodium dodecyl sulfate (SDS, USB Corporation): Prepare 1 % w/v SDS solution in sterile deionized water. Store this solution at room temperature.
3. Micro BCA Protein Assay Kit (Thermo Fisher Scientific Inc.): For the determination of encapsulation efficiency, prepare the protein concentration standards in 1 % SDS while for the in vitro release studies, protein concentration standards should be made in PBS. Use bovine serum albumin (BSA) or any other suitable protein to make protein concentration standards.

2.4 Materials Required for Evaluation of IgG Response

1. HRP conjugated goat anti-mouse IgG (Santa Cruz Biotechnology): Prepare the 1:10,000 dilution of HRP conjugated goat anti-mouse IgG using phosphate buffered saline (PBS), pH 7.4.
2. TMB substrate reagent set kit (BD OptEIA™, BD Biosciences): The kit is kept at 4 °C. Allow the solution to reach room temperature before use. Mix equal volumes of solution A and B just before use.

3 Method

3.1 Purification of Recombinant Protective Antigen Domain 4 (PAD4)

1. Grow PAD4 expression plasmid transformed *E. coli* cells in LB medium supplemented with 50 µg/ml kanamycin at 37 °C with shaking/aeration (200 rpm, incubator shaker) to absorbance of 0.8 at 600 nm.
2. Induce the bacterial cells with 1 mM isopropyl β-D-1-thiogalactopyranoside (IPTG).
3. Allow bacterial cells to grow at 37 °C for 4 h.
4. Separate the bacterial cells from culture medium by centrifugation at 5000 ×g for 10 min at 4 °C. Collect the bacterial cells as pellet.

5. Lyse the bacterial cells from 1 L of shake flask culture in 100 ml of denaturing lysis buffer (8 M urea, 0.1 M phosphate buffer, 300 mM NaCl, pH 7.2) on a rotatory shaker for 2 h at room temperature.
6. Remove the insoluble fraction of bacterial cell lysate by centrifugation at $15,000\times g$ for 30 min at 15 °C.
7. Incubate the solubilized fraction of bacterial cell lysate with Ni-NTA slurry pre-equilibrated with denaturing lysis buffer on a rotatory shaker for 2 h.
8. Transfer the mix to a 5 ml propylene tube column (Qiagen Inc.) and then renature the slurry bound PAD4 by sequentially passing a step gradient of renaturation buffers containing urea from 8 M to 0 M in 0.1 M phosphate buffer, 300 mM NaCl, pH 7.2. Pass 4 ml of each step gradient of renaturation buffer through column. The steps after 4 M urea gradient should be carried out at 4 °C.
9. Sequentially wash the column with 20 bed volume of Wash buffer A (50 mM imidazole, 300 mM NaCl, 0.1 M phosphate buffer, pH 7.4) followed by 10 bed volume of Wash buffer B (100 mM imidazole, 300 mM NaCl, 0.1 M phosphate buffer, pH 7.4) (*see Note 2*).
10. Elute the column bound PAD4 with 4 ml of Elution Buffer (300 mM imidazole, 300 mM NaCl, 0.1 M phosphate buffer, pH 7.4).
11. Concentrate the purified PAD4 using Macrosep® advance centrifugal devices of 3 kDa cutoff (Pall Corporation, MI, USA) as per the manufacturer's direction (*see Notes 2–4*).
12. Check the purity of concentrated PAD4 using SDS-PAGE followed by gel densitometry analysis as described [11]. Check the concentration of recombinant PAD4 using standard micro-bicinchoninic acid BCA assay for protein as indicated below.

3.2 Preparation of PAD4 Nanoparticles

1. Use 4 ml of DCM as organic phase to dissolve 200 mg of PLGA (*see Note 1*).
2. Use 100 μ l aliquot of concentrated recombinant PAD4 (10 mg/ml) as internal aqueous phase (*see Notes 2–5*).
3. Prepare w/o emulsion by sonication using 2 mm stepped microtip at 35 % amplitude for 60 s (750 W; Sonic Vibra Cell Sonicator). Keep emulsion on ice-water bath during whole sonication process (*see Note 6*).
4. Transfer the w/o emulsion prepared to 12 ml of 1 % PVA which is used as an external aqueous phase.
5. Sonicate the mixture using 6 mm stepped tip at 30 % amplitude for 110 s to generate the w/o/w emulsion.

6. Keep the emulsion stirred for 6 h for the evaporation of DCM and hardening of the nanoparticles prepared, i.e., PAD4-NP (*see Note 7*).
7. Separate the PAD4-NP prepared from external aqueous phase containing 1 % PVA by centrifugation at $15,000 \times g$ for 15 min at 4 °C.
8. As the PVA often contaminate the PLGA nanoparticles, wash the PAD4-NP three times with sterile cold deionized water. To wash the nanoparticles, suspend them in 5 ml of deionized water, then centrifuge at $15,000 \times g$ for 15 min at 4 °C to separate the nanoparticles. Repeat the process.
9. Suspend PLGA encapsulated PAD4 nanoparticles (PAD4-NP) in 5 ml of sterile deionized water and place in liquid nitrogen for quick freezing to avoid phase separation (*see Note 8*).
10. Keep nanoparticles in -80 °C for 1 h and then lyophilize at -54 °C and 0.003 mbar for 18 h (*see Note 9*).
11. For storage, keep the final PAD4-NP preparation at -20 °C.

3.3 Determination of Encapsulation Efficiency

The encapsulation efficiency of PAD4 in PLGA nanoparticles can be estimated using micro-bicinchoninic acid assay (micro-BCA assay).

1. Suspend 10 mg of PAD4-NP in 1 ml of acetonitrile (*see Note 10*).
2. Vortex for 1 min and centrifuge at $10,000 \times g$ for 10 min.
3. Collect the pellet and repeat the above process for three times.
4. Dissolve the final pellet in 500 μ l of 1 % SDS.
5. Estimate the encapsulated protein content by micro-BCA assay using BSA dissolved in 1 % SDS as standard (*see Note 11*).
6. Calculate the overall efficiency of nanoparticle production process in terms of the yield of the nanoparticle formulation process, encapsulation efficiency, and loading efficiency using the following formulae:

$$\% \text{ Yield} = \left(\frac{\text{Weight of dried encapsulated nanoparticles}}{\text{Weight of PLGA polymer used for encapsulation}} \right) \times 100.$$

$$\text{Encapsulation efficiency} = \left(\frac{\text{Total weight of encapsulated protein}}{\text{Total protein (weight) used for encapsulation}} \right) \times 100\%$$

$$\text{Loading efficiency} = \left(\frac{\text{Total weight of encapsulated protein}}{\text{Total weight of nanoparticles}} \right) \times 100\%$$

3.4 Morphological Characterization of Nanoparticles

Morphological characteristics of PAD4-NP can be evaluated using scanning electron microscope such as Zeiss EVO40 (Carl Zeiss, Thronwood, NY) and transmission electron microscope JEM 2100F (Jeol Ltd., Tokyo, Japan) as done by us [11].

1. For scanning electron microscopy, spread dried microspheres on a carbon tape of an aluminum stub (*see Note 12*).
2. Make the nanoparticles conductive by coating them with gold particles using a sputter coater (Polaron SC7640) at 2 kV for 200 s under inert argon environment.
3. Observe the nanoparticles under high tension voltage and magnification (e.g., 20 kV and 40.76 K magnification) using Zeiss EVO40 scanning electron microscope. The scanning electron micrograph of PAD4-NP prepared using this method is shown as Fig. 2.
4. For the transmission electron microscope imaging, dissolve the PAD4-NP in deionized water at 0.1 mg/ml concentration.
5. Sonicate the suspension for 1 s to disperse the nanoparticles, then place them on a carbon film with 200 mesh copper grids (Electron microscopy sciences, Hatfield, PA).
6. Obtain transmission images of the nanoparticles under high vacuum, voltage of 200 kV and a direct magnification of 25,000 \times (JEM 2100F).

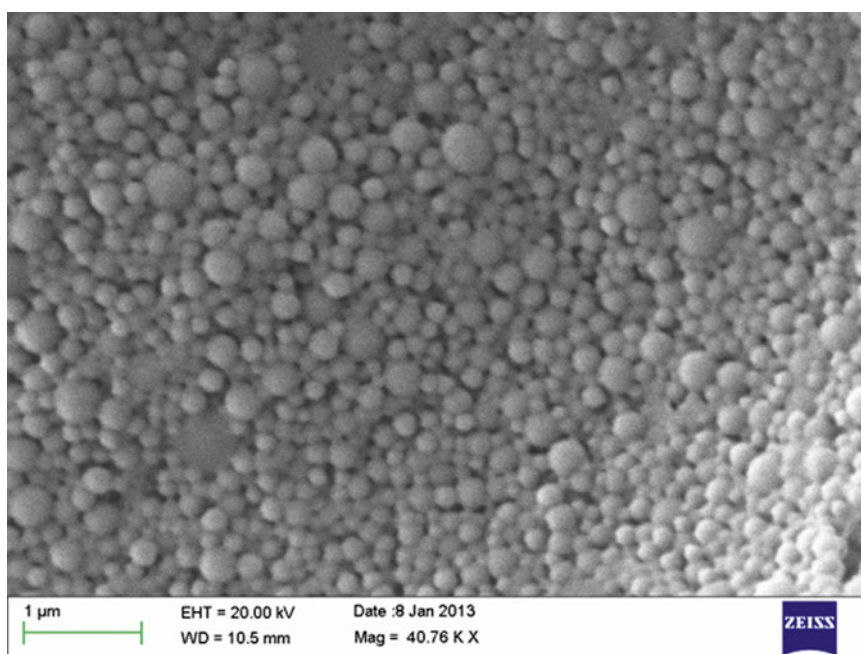

Fig. 2 Scanning electron micrograph of PAD4-NP. Figure shows the morphological characteristics of PAD4-NPs generated using the method described. PAD4-NPs have smooth surface, spherical shape, and size in the nanometer range

3.5 Determination of Size of PAD4-NP

Size of the nanoparticles can be estimated by dynamic light scattering using systems such as Nano ZS system (Malvern Instruments Ltd., Worcestershire, UK) that employs a He-Ne laser (wavelength 633 nm) or any other compatible system.

1. Prepare a dilute suspension of nanoparticle (0.1 mg/ml) in PBS (pH 7.4). A dilute sample suspension should be used for the calculation of size so as to avoid the particle–particle interaction and problem of multiple scattering.
2. Keep the nanoparticle suspension in disposable folded capillary cell and estimate the size of the particles using Nano ZS software suite.

3.6 In Vitro Release Studies

To study release of encapsulated protein antigen from PLGA based nanoparticles (e.g., PAD4-NP) when kept in aqueous suspension, the nanoparticles can be suspended in appropriate aqueous buffer systems and the release of the protein in aqueous environment with time can be estimated using micro-BCA assay as described below for the PAD4-NP prepared above:

1. Suspend the PAD4-NP aliquots in 1.5 ml of 0.1 M PBS (pH 7.4) and incubate at 37 °C under mild agitation.
2. Label the aliquots for different time point such as 4 h, 1 day, 3 days, 7 days, 14 days, and 28 days.
3. Collect the supernatant at respective time point by centrifugation at $15,000 \times g$ for 20 min at 4 °C.
4. Determine the protein content in supernatant using micro-BCA assay as discussed above (*see Note 11*).
5. Generate the PAD4 release profile from PAD4-NP by calculating the fractional protein or antigen release, i.e., $(\text{PAD4 released}/\text{PAD4 encapsulated}) \times 100 \%$.

3.7 Immunization

The PLGA encapsulated protein antigen nanoparticles can be evaluated for immunogenicity or conferring protective immunity using different mice model systems such as for the PAD4-NP produced above is described below:

1. For immunization studies, procure 8–10 week old outbred female Swiss Webster mice.
2. Divide mice into four groups of ten animals each.
3. Immunize all groups with single dose and adjuvant free immunization schedule. The route of immunization can be intraperitoneal (i.p.) and the dose volume can be up to 100 μl per injection as used for PAD4-NP (*see Notes 13 and 14*).
4. Immunize the animal groups with PAD4-NP (encapsulating 100 μg of PAD4), PAD4 (50 μg), blank nanoparticles or PBS alone.

5. Collect the sera from immunized mice on days 14 and days 28 post-immunization.

3.8 Evaluation of IgG Response

The IgG response generated on immunization with any PLGA encapsulated antigen nanoparticle formulation can be estimated using standard enzyme linked immunosorbent assay (ELISA) such as described below for the PAD4-NP:

1. Perform enzyme linked immunosorbent assay (ELISA) to estimate the anti PAD4-IgG titer generated as a result of PAD4-NP immunization using 96-well, flat bottom, polystyrene plates (Nunc-immuno™ maxisorp).
2. Coat each well with 100 µl of PAD4 (5 µg/ml) diluted in PBS (pH 7.4) by incubating it overnight at 4 °C.
3. Wash the wells for three times with PBST (PBS containing 0.05 % tween-20) using microplate liquid handling system (e.g., Tecan Columbus pro washer).
4. Block the wells with 10 % FBS in PBS and wash them five times with PBST.
5. Serially dilute the collected serum from mice immunized with PAD4-NP, PAD4, Blank-NP and PBS in PBS.
6. Keep the 100 µl of serum dilutions in polystyrene plate alongside with respective serum dilutions from unimmunized mice/control mice in 96-well polystyrene plate.
7. Incubate the plate for 2 h at room temperature.
8. Wash the wells with PBST for five times using microplate liquid handling system (e.g., Tecan Columbus pro washer).
9. Incubate the wells with 100 µl of HRP conjugated goat anti-mouse IgG (sc2005, Santa Cruz Biotechnology) at the dilution of 1:10,000 for 1 h.
10. After five time washing with PBST, add 100 µl of TMB substrate reagent (BD OptEIA™) in each wells and incubate for 30 min. The TMB substrate reagent should be at room temperature before use.
11. Stop the reaction using 50 µl of 2 N H₂SO₄ and measure the absorbance at 450 nm followed by background subtraction of absorbance at 570 nm (Tecan Sunrise absorbance reader).
12. Calculate the cutoff for every serial dilution with confidence interval 99 % for an increased specificity. A higher confidence interval can be used to reduce the over estimation of IgG titer. A table for the multiplication factors for different levels of confidence intervals can be obtained from the work of Frey et al. [17]. It displays dependence on the number of wells used for control sera.
13. Calculate the end point titer as the reciprocal of highest dilution having absorbance above the cutoff. This is done to evaluate the IgG response after immunization with PAD4-NP.

4 Notes

1. The PLGA forms the matrix of nanoparticles. The concentration of PLGA can be varied to modulate the antigen release kinetics and the encapsulation efficiency. We dissolve the PLGA at the concentration of 50 mg/ml in DCM. Ease of solubility in organic solvent such as DCM is dependent on the lactide content. PLGA with lactide and glycolide content in 50:50 ratio will take more time to dissolve than that with 85:15 ratio. As the evaporation rate of DCM is high, remove the DCM from sure seal bottle using glass syringes. Keep a 2 mm rice shaped magnetic beads in glass vials and then add 200 mg PLGA. Let the solution stir for 20 min in 4 ml of DCM. When the PLGA gets dissolved, use a bigger magnetic bead to remove the small magnetic beads by sliding through wall of glass vial and without disturbing the organic phase solvent. Avoid any aqueous contaminant in organic phase and keep the cap of glass vial closed during dissolution of PLGA to prevent the evaporation of DCM.
2. A slight increase in pH is done during washing steps to increase the binding of recombinant PAD4 with Ni-NTA beads in rigorous washing conditions. In the w/o/w solvent evaporation method, the internal aqueous phase contains the antigen which needs to be encapsulated and the volume of internal aqueous phase is kept low to obtain nanometer sized particles. These constraints require the recombinant protein at high concentration with high purity. Hence extensive washing is done to remove impurities and to achieve a homogenous recombinant PAD4 preparation.
3. The ratio of aqueous phase (containing PAD4) to oil phase (containing PLGA) affects the particle size, i.e., the greater the internal aqueous phase the bigger dimension particles will be formulated. As our objective is to make nanometer size particles, we try to keep the internal aqueous phase as low as possible. Furthermore, to have a better loading efficiency we need to have more amount of antigen in the internal aqueous phase. Hence, the concentrated sample of PAD4 preparation (10 mg/ml) was used for encapsulation.
4. Recombinant proteins frequently aggregate/precipitate at higher concentration [15]. However, this was not observed in the case of recombinant PAD4.
5. For preparing blank nanoparticle, only PBS can be used as internal aqueous phase.
6. Organic phase is heavier than aqueous phase. Hence, the aqueous phase should be added dropwise to prevent the formation of bigger droplet on the surface of organic phase. Slowly dipping the sonicator tip with dropwise addition of aqueous phase will result in the properly mixed emulsion.

7. 4 ml of dichloromethane often evaporates in 6 h at room temperature. When the dichloromethane evaporates, the particles come in direct contact with aqueous solution containing PVA. A prolonged stirring after evaporation will result in lower encapsulation efficiency because of the initial burst release of antigen in aqueous environment induced by surface erosion of particles by water.
8. While transferring the nanoparticle suspension from centrifuge tube to 50 ml propylene tube for lyophilization, first weigh the empty propylene tube with cap then transfer the nanoparticle suspension to it. Once the preparation has lyophilized, weigh again the polypropylene tube (containing nanoparticles) with cap. The weight differential is your nanoparticle yield from the starting material. This can be used for calculating particle yield.
9. Normally it takes 18 h to dry the nanoparticles. Weigh the polypropylene tube after lyophilization. Normally the particle yield using this method is 70–80 %.
10. Acetonitrile dissolves the polymers but precipitates the protein. As for estimation of the protein content in PAD4-NP, the PAD4 needs to be brought into solution. We used 1 % SDS to solubilize the PAD4 pellet obtained from acetonitrile washing.
11. The linear range of micro BCA assay when carried out in microplate format is 2–40 $\mu\text{g}/\text{ml}$. Hence, the proper dilution of the test solution should be made, so that the absorbance should fall in a linear range. The standards of protein BSA should also be made in the 1 % SDS for the determination of encapsulation efficiency, whereas in PBS to estimate the in vitro antigen release.
12. Only a 1–2 mg of nanoparticles will be sufficient for visualizing the morphology using scanning electron microscopy. Spread the nanoparticle on the carbon tape to form a thin layer. It is not necessary to cover the entire surface of carbon tape.
13. Suspend the nanoparticles in PBS solution at the time of immunization. As the PLGA particles prepared can show a burst release of antigen, the longer exposure in aqueous solution before immunization should be avoided. Normally, 25 mg of PLGA particles can be suspended easily in 100 μl of PBS.
14. The immunized mice can be further evaluated for protective efficacy against lethal dose of *Bacillus anthracis* Sterne strain. To evaluate the protective efficacy, challenge the immunized mice with a dose of 0.4×10^8 spores per mouse on day 40 and estimate the protective efficacy using Kaplan–Meier survival estimates (GraphPad Prism, La Jolla, CA) as reported previously (see Ref. 11).

Acknowledgements

The work was supported in part by funding from the Department of Biotechnology (DBT) and Department of Science and Technology (DST), India. MM is a recipient of Fulbright Fellowship, Utrecht University short stay Fellowship, CSIR, SBRI-India GID Fellowship (NIH Research Grant number D43 TW000924 funded by the Fogarty International Center), and ICMR Fellowship. SS is a recipient of Ramalingaswami Fellowship of DBT, India.

References

1. Akagi T, Baba M, Akashi M (2012) Biodegradable nanoparticles as vaccine adjuvants and delivery systems: regulation of immune responses by nanoparticle-based vaccine. In: Shigeru K, Yamaoka T (eds) *Polymers in nanomedicine*, vol 247. Springer, Berlin, Heidelberg, pp 31–64
2. Anderson JM, Shive MS (2012) Biodegradation and biocompatibility of PLA and PLGA microspheres. *Adv Drug Deliv Rev* 64:72–82
3. Li H, Ma W (2014) Intracellular delivery of tumor antigenic peptides in biodegradable-polymer adjuvant for enhancing cancer immunotherapy. *Curr Med Chem* 21:2357–2366
4. Bolhassani A, Javanad S, Saleh T et al (2014) Polymeric nanoparticles: potent vectors for vaccine delivery targeting cancer and infectious diseases. *Hum Vaccin Immunother* 10:321–332
5. Van de Weert M, Hennink WE, Jiskoot W (2000) Protein instability in poly(lactic-co-glycolic acid) microparticles. *Pharm Res* 17:1159–1167
6. Cleland JL, Powell MF, Shire SJ (1993) The development of stable protein formulations: a close look at protein aggregation, deamidation, and oxidation. *Crit Rev Ther Drug Carrier Syst* 10:307–377
7. Zhu G, Mallery SR, Schwendeman SP (2000) Stabilization of proteins encapsulated in injectable poly(lactide-co-glycolide). *Nat Biotechnol* 18:52–57
8. Williams AS, Lovell S, Anbanandam A et al (2009) Domain 4 of the anthrax protective antigen maintains structure and binding to the host receptor CMG2 at low pH. *Protein Sci* 18:2277–2286
9. Scobie HM, Rainey GJ, Bradley KA, Young JA (2003) Human capillary morphogenesis protein 2 functions as an anthrax toxin receptor. *Proc Natl Acad Sci U S A* 100:5170–5174
10. Flick-Smith HC, Walker NJ, Gibson P et al (2002) A recombinant carboxy-terminal domain of the protective antigen of *Bacillus anthracis* protects mice against anthrax infection. *Infect Immun* 70:1653–1656
11. Manish M, Rahi A, Kaur M et al (2013) A single-dose PLGA encapsulated protective antigen domain 4 nanoformulation protects mice against *Bacillus anthracis* spore challenge. *PLoS One* 8, e61885
12. Rahman Z, Zidan AS, Habib MJ, Khan MA (2010) Understanding the quality of protein loaded PLGA nanoparticles variability by Plackett-Burman design. *Int J Pharm* 389:186–194
13. Ye M, Kim S, Park K (2010) Issues in long-term protein delivery using biodegradable microparticles. *J Control Release* 146:241–260
14. Roberts RA, Shen T, Allen IC et al (2013) Analysis of the murine immune response to pulmonary delivery of precisely fabricated nano- and microscale particles. *PLoS One* 8, e62115
15. Bondos SE, Bicknell A (2003) Detection and prevention of protein aggregation before, during, and after purification. *Anal Biochem* 316:223–231
16. Gorantala J, Grover S, Goel D et al (2011) A plant based protective antigen [PA(dIV)] vaccine expressed in chloroplasts demonstrates protective immunity in mice against anthrax. *Vaccine* 29:4521–4533
17. Frey A, Di J, Zurakowski D (1998) A statistically defined endpoint titer determination method for immunoassays. *J Immunol Methods* 221:35–41

Attenuated *Salmonella* sp. as a DNA Delivery System for *Trypanosoma cruzi* Antigens

Augusto E. Bivona, Natacha Cerny, Andrés Sánchez Alberti, Silvia I. Cazorla, and Emilio L. Malchiodi

1 Introduction

Trypanosoma cruzi is an intracellular protozoan parasite and the etiological agent of Chagas disease, the major cause of death from cardiomyopathy in endemic Latin America. The parasite is mainly transmitted to humans by infected feces of triatomine insects that feed on mammals' blood. According to the World Health Organization estimates, the number of infected people globally amounts to eight million, and more than 10,000 deaths are thought to occur annually (World Health Organization. WHO Fact Sheet No 340. <http://www.who.int/mediacentre/factsheets/fs340/en/>). To date there is no safe and effective vaccine against *T. cruzi* infection.

In this chapter we describe the use of attenuated *Salmonella* as a live Trojan horse *T. cruzi* antigen. The widespread use of *Salmonella* as a vaccine vector relies on the easiness with these bacteria for genetic modification, the existence of the serovar Typhimurium mouse model for preclinical work and a positive previous human experience with a FDA-approved live attenuated vaccine *S. typhi* Ty21a for typhoid fever (<http://www.cdc.gov/vaccines/hcp/vis/visstatements/typhoid.html>).

Salmonella elicits a strong innate immune response due to many pathogen-associated molecular patterns (PAMPs) present in the bacteria, such as LPS [1], bacterial CpG [2, 3], flagellin or bacterial lipoproteins [4, 5] that stimulate antigen presenting cells to mature and migrate to secondary lymph node, to initiate an adaptive response. In this manner, *Salmonella*-derived PAMPs

Augusto E. Bivona and Natacha Cerny contributed equally.

amplify the immune response against the transported *T. cruzi* antigens acting as adjuvants.

Salmonella-based vaccine effectiveness and versatility lie on the plasticity of the immune response modulated by *Salmonella*. Different arms of the immune system, both humoral [6, 7] and cell-mediated responses, including CD4+ T cells [8, 9], cytotoxic CD8+ T cell (CTL) [10, 11], secretion of inflammatory cytokines and chemokines, upregulation of co-stimulatory molecules and regulatory T cells (Tregs) [12–14], are known to be induced at mucosal and systemic level with *Salmonella* infection and mediate protection against different diseases.

Immunity to *Salmonella* is mainly Th1-cell dependent and consequently, Th1-biased immune responses are usually elicited against the antigens delivered by *Salmonella*, which includes elevated IFN- γ production and IgG2a antibody production in mice as well as cytotoxic CD8+ T cells toward the antigens. The major advantage of live vectors is that they produce the antigen in its native conformation, which is important for generating neutralizing antibodies and can facilitate antigen entry into the MHC class I processing pathway for the induction of CD8+ CTL. Considering *T. cruzi* is an intracellular protozoan parasite, which cycles between intracellular and extracellular stages, the *Salmonella* induced immune response is highly encouraging in the search for *T. cruzi* immunoprotection.

Recent studies on Chagas disease identified antigens, adjuvants, and immunization route for vaccines against this disease. In that sense, *Salmonella* spp. as DNA delivery system of several *T. cruzi* antigens has demonstrated to elicit a strong mucosal and systemic immune response able to control the acute phase of the parasites infection. Most importantly this strategy was also effective in preventing or restricting the generation of tissue pathology at the chronic stage of *T. cruzi* infection [8, 9, 11, 15].

Increased understanding of the mechanisms underlying *Salmonella* virulence and host immune response will continuously create novel strategies for more effective *Salmonella*-based vaccines. This technical advance will open a new avenue for the effective development of *Salmonella*-based vaccines for prevention or therapy of *T. cruzi* infection in human and animals.

2 Materials

2.1 Cloning of *T. cruzi* Antigen in an Eukaryotic Expression Plasmid

1. PCR amplification reagents: DNA polymerase, dNTPs, DNA polymerase 10 \times buffer with MgSO₄. PCR dNTPs. PCR forward and reverse primers.
2. Thermal cycler with hot lid.
3. pCDNA3.1 plasmid.
4. Restriction enzymes and respective buffers.

5. Milli-Q sterilized water.
6. Agarose gel electrophoresis equipment.
7. QIAquick Gel Extraction Kit (QIAGEN).
8. Ligation Kit: T4 DNA Ligase, its corresponding ligation buffer and nuclease-free (dH₂O).
9. *E. coli* DH5- α competent cells.
10. LB (Luria Bertani broth) medium with ampicillin: Dissolve 5 g of peptone, 2.5 g of yeast extract, and 5 g of NaCl with 450 ml of distilled water or dH₂O in 500 ml cylinder. Make up to 500 ml with distilled water or dH₂O. Sterilize the solution in a bottle for 20 min at 121 °C, cool the solution at room temperature, and then add 100 μ l of 100 mg/ml of ampicillin.
11. LB agar plates with ampicillin: Dissolve 5 g of peptone, 2.5 g of yeast extract, and 5 g of NaCl with 450 ml of distilled water or dH₂O in 500 ml cylinder. Make up to 500 ml with distilled water or dH₂O. Transfer the solution in a bottle and add 7.5 g of agar. Sterilize for 20 min at 121 °C, cool the solution and then add 100 μ l of 100 mg/ml of ampicillin. Pour carefully into 10 mm petri dishes avoiding bubbles. Allow gel to solidify.
12. QIAprep Miniprep Kit (Qiagen).
13. Sequencing service.

2.2 Transfection of BHK-A Cells

1. BHK-A cell line.
2. Lipofectamine™ 2000 (Invitrogen).
3. pcDNA3.1 expressing *T. cruzi* antigen.
4. Incomplete DMEM medium (without antibiotics).
5. Sterile 24-well plates.
6. Complete DMEM medium with antibiotics and 10 % of fetal bovine serum (FBS).
7. Incubator at 37 °C and 5 % of CO₂ humidified environment.
8. Coverslip (diameter: 12 mm).
9. PBS (Phosphate-buffered saline): 10 mM Na-phosphate pH 7.5, 0.9 % (w/v) NaCl.
10. Paraformaldehyde 4 % in PBS.
11. Immunofluorescent Blocking/Permeabilization Buffer: 0.5 % saponin, 10 % FBS in PBS.
12. Serum specific for the *T. cruzi* antigen cloned.
13. FITC-conjugated secondary antibody heavy chain.
14. Slides.
15. Fluorescence microscope.

2.3 Preparation of *Salmonella* Competent Cells

1. *Salmonella enterica* serovar Typhimurium aroA 7207.
2. Sterile liquid BHI (brain heart infusion) medium.
3. BHI-agar plates supplemented with ampicillin (100 µg/ml) (prepared similar as is indicated in Subheading 2.1, item 11).
4. Orbital shaker, 37 °C.
5. Absorbance reader.
6. 0.1 M CaCl₂ filtered.
7. Sterile glycerol for molecular biology (99 %).
8. Sterile distilled water.

2.4 Transformation of Competent *Salmonella*

1. *Salmonella* competent cells.
2. pcDNA plasmid encoding *T. cruzi* antigen.
3. Sterile liquid BHI medium (prepared similar as is indicated in Subheading 2.1, item 10).
4. Orbital shaker, 37 °C.
5. Water bath.
6. BHI-agar plates supplemented with ampicillin (100 µg/ml).
7. Sterile electroporation cuvette.
8. Gene Pulser.

2.5 *Salmonella* Calibration Curve and Mice Immunization

1. *Salmonella* carrying the pcDNA plasmid encoding *T. cruzi* antigen.
2. Sterile liquid BHI medium.
3. BHI-agar plates supplemented with ampicillin (100 µg/ml) (prepared similar as is indicated in Subheading 2.1, item 11).
4. Orbital shaker, 37 °C.
5. Absorbance reader.
6. Buffer Immunization: 2.65 % NaHCO₃, 1.65 % ascorbic acid, 0.2 % lactose pH 7. Filter at 0.22 µm.

3 Methods

3.1 Directional Cloning of *T. cruzi* Antigen on Eukaryotic Expression Vector pcDNA 3.1

1. Amplify the DNA sequence encoding for *T. cruzi* antigen by PCR including different restriction sites in the forward and reverse primers (see Note 1).
2. Digest antigen sequence and pcDNA3.1 plasmid with the corresponding restriction enzymes (follow the protocols of enzyme's brand). *Example:* For 20 µl reaction: 1 µg DNA (antigen DNA or pcDNA 3.1), 2 µl of 10× Reaction Buffer, 1 unit (see Note 2) of each enzyme and complete the volume with ddH₂O. Incubate for 1–2 h at 37 °C.

3. Perform an agarose gel electrophoresis (in Tris–acetate EDTA buffer) to check the digestion, and purify digested DNA with a DNA gel extraction kit (e.g., QIAGEN).
4. Ligation: mix digested and purified antigen DNA-pcDNA3.1 vector in an insert–vector molar ratio of 1:1, 3:1, or 10:1 (*see Note 3*). Add 1 μ l of 10 \times ligation buffer, 0.4 μ l of T4 ligase and dH₂O to 10 μ l. Incubate for 24–48 h at 16 °C.

3.2 *T. cruzi* Protein Expression in Mammalian Cells In Vitro

Mammalian expression of *T. cruzi* antigens could be tested by transient transfection of BHK-A cells with the pcDNA3.1-*T. cruzi* antigen construct. Transfection protocol is based on Invitrogen™'s Lipofectamine® Transfection Reagent (Life Technologies).

1. Place sterilized coverslips in the bottom of wells of a 24-well plate.
2. The day before transfection, seed 1×10^5 BHK-A cells/well in 0.5 ml of the appropriate complete growth medium (DMEM containing 10 % FBS). Incubate the cells at 37 °C in a CO₂ incubator until the cells are 50–80 % confluent.
3. For each well, dilute 0.2–0.4 μ g of the pcDNA-*T. cruzi* antigen construct into 25 μ l medium without serum. On the other hand, dilute 0.5–5 μ l of Lipofectamine® reagent into 25 μ l medium without serum and mix.
4. Mix gently the diluted pcDNA-insert and Lipofectamine® solutions and incubate at room temperature for 15–45 min. While lipocomplexes are forming, replace the medium on the cells with 0.2 ml of medium without serum (*see Note 5*).
5. For each transfection, add 0.15 ml of medium without serum to the tube containing the complexes. Mix gently and overlay the diluted complex solution onto the rinsed cells. Medium containing serum may be added to the complexes at this step. Do not add antibacterial agents to media during transfection.
6. Incubate the cells with the complexes for 2–24 h at 37 °C in a CO₂ incubator.
7. Following incubation, add 0.4 ml of growth medium containing twice the normal concentration of serum without removing the transfection mixture. If serum has been included in **step 5**, add 0.4 ml of complete growth medium this time (*see Note 6*).
8. Replace the medium with fresh complete medium at 18–24 h following the start of transfection if continued cell growth is required.
9. Check antigen expression by Indirect Immunofluorescence (IFI):
 - (a) After 24–72 h from cell transfection, wash them twice with 1 ml of PBS and then fix them with 2 ml of 4 % paraformaldehyde for 10 min at room temperature. Rinse cells twice with 1 ml of PBS.

- (b) Block nonspecific binding sites by adding 2 ml of Blocking/Permeabilization Buffer and incubating for 30 min at 4 °C.
- (c) Prepare an appropriate dilution of the specific *T. cruzi* antigen antibody in permeabilization buffer.
- (d) Incubate the cells with 100–200 µl of antibody dilution (ensure to cover the entire coverslip's surface) for 1 h at room temperature and then wash twice with permeabilization buffer.
- (e) Prepare an appropriate dilution of the FITC-conjugated secondary antibody in permeabilization buffer.
- (f) Incubate the cells with 100–200 µl of the secondary antibody dilution (ensure to cover the entire coverslip's surface) for 1 h at room temperature (in the dark) and then wash twice with permeabilization buffer.
- (g) Wash cells twice with 1 ml of PBS and mount the coverslip with a drop of mounting medium over a slide.
- (h) Seal coverslip with nail polish to prevent drying and movement under fluorescence microscope.
- (i) Observe under the microscope to check antigen expression or store at 4 °C.

After verifying their optimal expression in mammalian cells, pCDNA3.1-*T. cruzi* antigen construct will be used to transform attenuated *Salmonella enterica* serovar Typhimurium aroA.

3.3 Preparation of Competent *Salmonella* sp.

Competent *Salmonella* can optionally be prepared following protocols I or II (*see Note 4*).

I. Calcium chloride treatment

1. In sterile conditions, inoculate from a stock of *Salmonella* strain (attenuated *Salmonella enterica* serovar Typhimurium aroA 7207) a petri dish by streaking a pattern gently across the entire agar surface without tearing into it. Incubate ON at 37 °C.
2. Touch a single colony with a sterile loop and inoculate 5 ml of BHI liquid medium with antibiotic. Incubate ON in a shaking incubator at 70–90 rpm with low aeration at 37 °C (*see Note 7*).
3. Take 200 µl of the overnight bacterial culture and dilute it in 10 ml of BHI medium. Grow at 37 °C in a shaking incubator at 70–90 rpm with low aeration until $OD_{600}=0.6-0.8$ (*see Note 8*).
4. Centrifuge the cultures at 10 °C for 10 min at $2000\times g$.
5. Discard the supernatant and suspend the cells slowly in 10 ml of cold sterile 0.1 M CaCl₂. Cells must remain cold for the rest of the procedure.

6. Incubate for 30 min on ice (4 °C).
7. Centrifuge the cells at 10 °C for 10 min at 4000 × *g*.
8. Resuspend the cell pellet in 1 ml of cold sterile 0.1 M CaCl₂ + 10 % glycerol.
9. Use the competent cells to transform immediately or snap-freeze them with liquid nitrogen and store the cells frozen at -80 °C.

II. Treatment for Electroporation

Proceed as calcium chloride treatment until point 4.

1. Incubate for 30 min on ice (4 °C).
2. Centrifuge the cells at 2000 × *g* 10 min.
3. Discard the supernatant and resuspend the cells slowly in equal volume of ice-cold sterile water.
4. Centrifuge the cells at 2000 × *g* 10 min.
5. Resuspend the cell pellet in 0.4 volumes of water at 0 °C.
6. Centrifuge the cells at 2000 × *g* 10 min.
7. Resuspend the pellets in 0.02 volumes of water at 0 °C.
8. Centrifuge the cells at 2000 × *g* 10 min.
9. Resuspend the pellets in 0.002 volumes of water with 10 % glycerol at 0 °C.
10. Prepare aliquots of 40 µl in individual eppendorf tubes on ice. Freeze immediately in liquid nitrogen and store the aliquots at -80 °C.

3.4 Transformation of *Salmonella* sp. with the Expression Vector Containing *T. cruzi* Insert

Following the protocols in Subheading 3.3, continue with steps I or II.

I. Transformation of calcium chloride competent cells

1. Take 2–5 µl of the pure pcDNA-*T. cruzi* antigen.
2. Mix slowly with 200 µl of *Salmonella* competent cells.
3. Incubate for 40 min on ice (4 °C).
4. In a preheated bath at 45 °C, incubate the sample for 45 s at 42 °C.
5. Mix with 1 ml of BHI medium and incubate for 1 h at 37 °C at 70–90 rpm. In the meantime incubate the BHI- agar petri plates containing the resistance antibiotic at room temperature.
6. Centrifuge the cells at 2000 × *g* 10 min and resuspend the pellet in 200 µl of medium.
7. Spread 100–200 µl of bacteria on BHI petri dish containing the resistance antibiotic.

8. Allow the cells to grow overnight at 37 °C.
9. Store plates at 4 °C no more than 1 week. Wrap plates in Parafilm to keep them from drying out.

II. Transformation of electroporated competent cells

1. Take a tube with 40 µl of *Salmonella* electro-competent cells and mix with 1–2 µl of the pcDNA-*T. cruzi* antigen and keep this sample on ice.
2. Transfer the mix into an electroporation cuvette and wipe the exterior of cuvette dry with a tissue and tap the cuvette lightly on the bench to release any air bubbles in the chamber.
3. Electroporate in a Bio-Rad Gene Pulser to 2.5 kV, 25 µF and capacitance extender to 200 Ω. Add 1 ml of BHI medium immediately.
4. Grow for 60 min at 37 °C and 70–90 rpm.
5. Centrifuge the cells at 2000 × *g* for 10 min and resuspend the pellet in 200 µl of medium.
6. Spread 100–200 µl of bacteria on BHI petri dish containing the resistance antibiotic.
7. Allow the cells to grow overnight at 37 °C.
8. Store plates at 4 °C for no more than 1 week. Wrap plates in Parafilm to keep them from drying out.

3.5 Determination of *Salmonella aro* A Volume To Be Grown for the Immunization-Calibration Curve

Before the immunization protocol it is important to make a calibration curve to estimate the amount of bacteria that should be inoculated in each mouse.

1. Take 500 µl of an overnight *Salmonella*-pcDNA-*T. cruzi* transformed bacterial culture and dilute in 20 ml of BHI medium.
2. Grow at 37 °C and 70–90 rpm with low aeration until OD₆₀₀ = 0.6–0.8.
3. At this time viable bacteria are determined by plate count agar. A set of serial dilutions has to be made and a sample of each appropriate dilution is spread on top of a solidified BHI/antibiotic agar petri plate, using a sterile glass spreader. Make duplicate plates (with the same amount plated) from one dilution and average the counts together (proceed as is in Scheme 1).
4. Incubate the plates overnight (16–24 h) at 37 °C.
5. Count the colonies of agar plates (*see Note 9*) and apply the following formula:

Colony count (CFU) on an agar plate ×
Total dilution of tube (used to make plate for colony count) = CFU / vol plated.

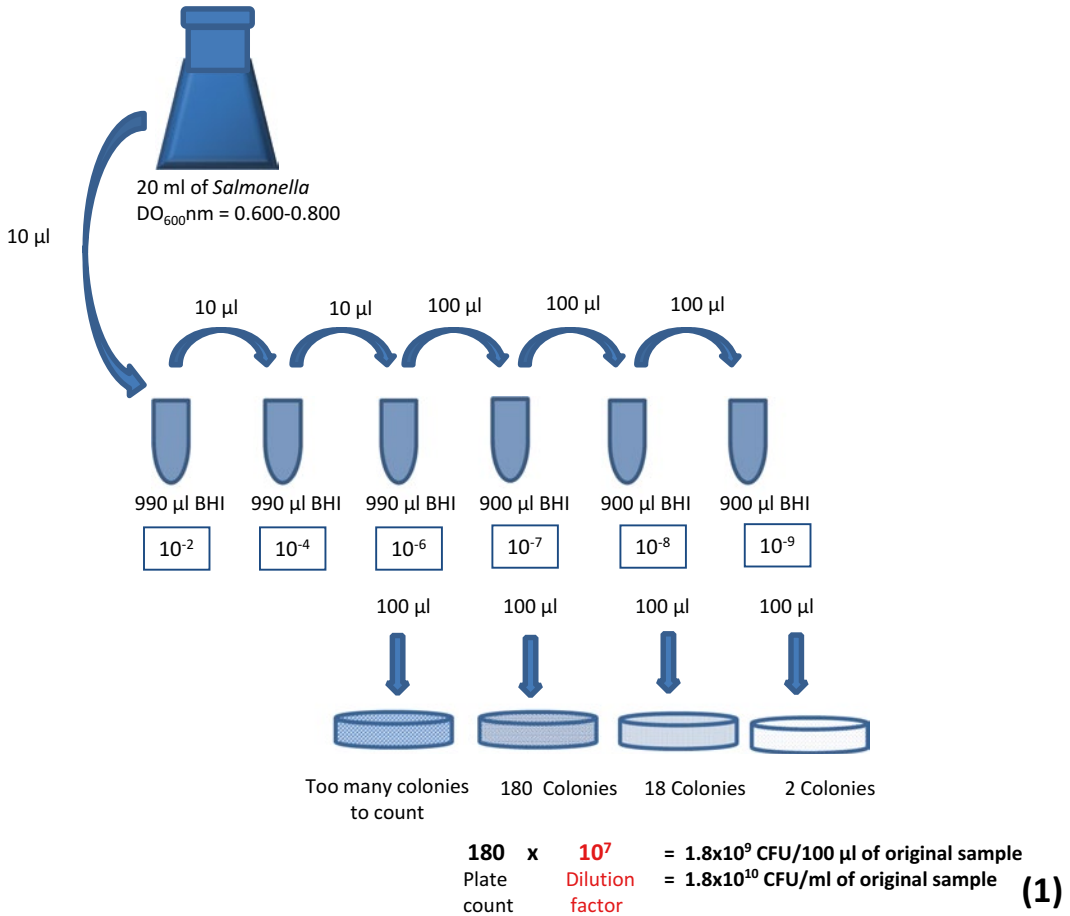

Scheme 1 Bacterial culture and counts: To determine colony forming units per milliliter (CFU/ml), serial dilutions of the *Salmonella* culture at optical density $OD_{600} = 0.6-0.8$ are made in brain heart infusion medium (BHI). Then, 100 µl of each dilution is spread on BHI agar plates. After overnight incubation at 37 °C, count colonies, multiply by the dilution factor, and calculate CFU/ml

6. Calculate the volume (V_1) of *Salmonella* required as:

$$V_1 = \frac{\text{Number of mice} \times \text{CFU of } Salmonella \text{ desired}}{\text{Previously calculated CFU/ml}} \quad (1)$$

Example:

$$\frac{30 \text{ mice} \times 10^9 \text{ CFU}}{1 \times 10^{10} \text{ CFU/ml}} = 3 \text{ ml}$$

7. Considering this V_1 has to be centrifuged and resuspended in immunization buffer before feeding the animals, it is important to determine the amount of bacteria recovered after the centrifugation.

Proceed as in **steps 1** and **2**, and as described previously, to make serial dilutions centrifuge 20 ml of *Salmonella* culture at 2000 ×g 10 min at 12 °C. Resuspend the pellet in 1 ml of BHI and proceed similarly as described previously (Scheme 2).

Example:

The amount of CFU expected in (2) is: 3.6×10^{11} , considering the number of *Salmonella* present in the original specimen (1.8×10^{10} CFU/ml) and the folds that the culture is concentrated (20). But the bacterial count determined in (2) is 1.2×10^{11} . This difference is due to some bacteria not recovered during the centrifugation. As a consequence, the appropriate volume of *Salmonella* to be grown for immunization (V_f) is:

$$V_f = V_1 \times 3 = \frac{\text{Number of mice} \times \text{CFU of } Salmonella \text{ desired}}{\text{Previously calculated CFU/ml}} \times \left(\frac{3.6 \times 10^{11}}{1.2 \times 10^{11}} \right) = 9 \text{ ml} \quad (2)$$

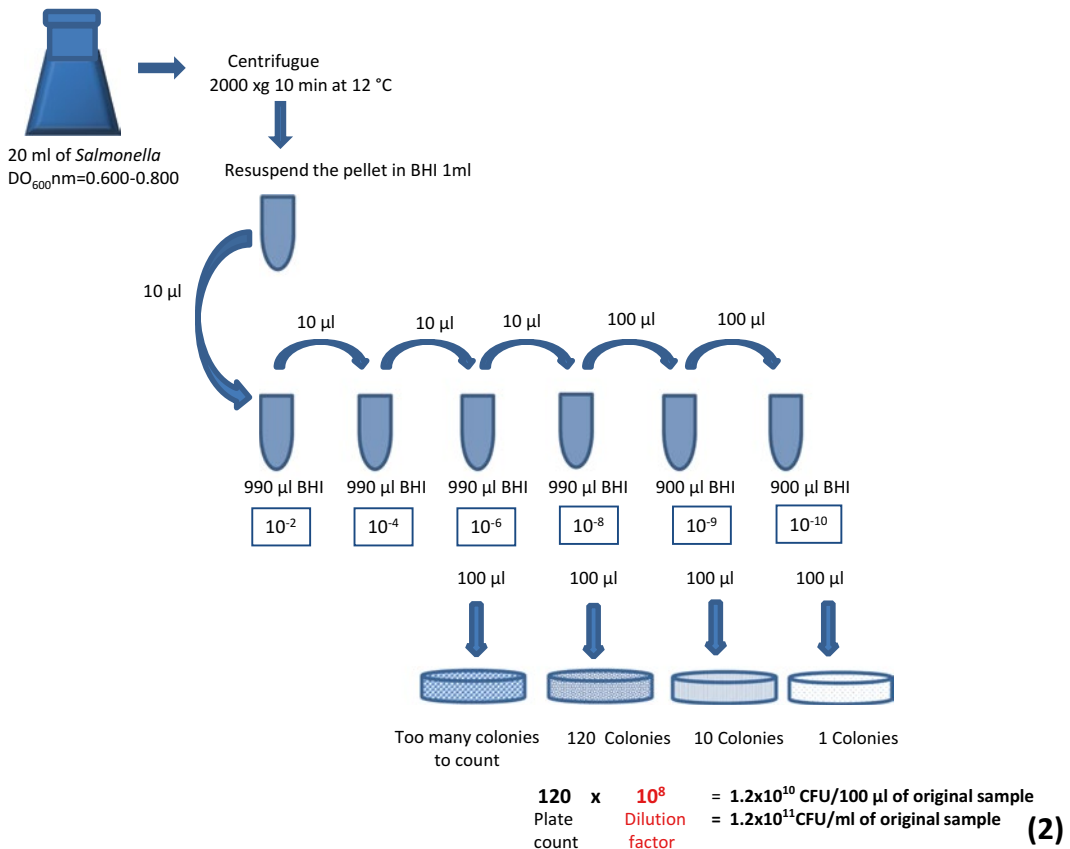

Scheme 2 Bacterial counts after centrifugation: To determine the amount of bacteria recovered after centrifugation, resuspend the pellet in 1 ml of BHI and proceed as in Scheme 1

3.6 Immunization

The oral immunization should be carried out by feeding each mouse with 20 μ l of immunization buffer (BI) carrying 10^9 CFU of the corresponding transfected *Salmonella*.

1. Mice are deprived of drinking water for 2 h.
2. Grow the previously determined volume (V_i) of *Salmonella* in BHI medium at 37 °C 80 rpm with low aeration until $DO_{600} \text{ nm} = 0.6\text{--}0.8$.
3. Centrifuge at $2800 \times g$ 10 min at 12 °C and resuspended in immunization buffer at the ratio of 20 μ l per mouse.

In the example:

Centrifuge 9 ml of *Salmonella* culture and resuspend in 600 μ l of immunization buffer.

4. Test in a sample, by plate count agar, if the CFU of *Salmonella* given to the mice is the desired. Proceed as described previously.
5. The mice are immunized on days 0, 10, 20, and 30 with the corresponding *Salmonella*.

4 Notes

1. When designing primers, make sure that restriction sites are present in the vector's multiple cloning site (poly-linker) in the correct order, and are absent in the insert sequence. It is also important to check previously the enzyme buffer compatibility in order to make restriction digests in one step.
2. The exact protocol depends on the enzyme brand. One enzymatic unit is defined as the amount of enzyme that digests 1 μ g of DNA in 50 μ l reaction in 60 min.
3. The amount of insert for different ratios may be calculated with the following formula:

$$\frac{\text{length of insert (kb)}}{\text{length of vector (kb)}} \times \text{ng of vector} = \text{ng of insert needed for 1:1 ratio.}$$

4. The methods described in Subheadings 3.3 and 3.4 for *Salmonella* can be also used to make competent *E. coli* DH5 α and transform them.
5. Some serum-free media formulations can inhibit cationic lipid-mediated transfection. Test media for compatibility with transfection reagent before use.
6. If toxicity is a problem, remove the transfection mixture and replace it with complete growth medium.

7. Culture at low aeration (no more than 90 rpm) allows for the expression of gene involved in the invasion of *Salmonella* to target cells (e.g.: macrophages).
8. This OD is reached in approximately 4–5 h of culture in the mentioned conditions.
9. The agar plate allows for accurate counting of the microorganisms that are equally distributed across the agar plate. Look at all plates and find one with 25–250 colonies. Less than 25 colonies is not acceptable for statistical reasons and a high count can be confounded by error in counting too many small colonies, or difficulty in counting overlapping colonies.

References

1. Wyant TL, Tanner MK, Sztein MB (1999) *Salmonella typhi* flagella are potent inducers of proinflammatory cytokine secretion by human monocytes. *Infect Immun* 67:3619–3624
2. Tokunaga T, Yamamoto H, Shimada S, Abe H, Fukuda T, Fujisawa Y, Furutani Y, Yano O, Kataoka T, Sudo T, Makiguchi N, Suganuma T (1984) Antitumor activity of deoxyribonucleic acid fraction from *Mycobacterium bovis* BCG. I. Isolation, physicochemical characterization, and antitumor activity. *J Natl Cancer Inst* 72:955–962
3. Krieg AM, Hartmann G, Yi AK (2000) Mechanism of action of CpG DNA. In: Wagner H (ed) *Immunobiology of bacterial CpG-DNA*. Springer-Verlag, Berlin, Heidelberg, pp 1–22
4. Hao G, Pitino M, Ding F, Lin H, Stover E, Duan Y (2014) Induction of innate immune responses by flagellin from the intracellular bacterium. *BMC Plant Biol* 14:211 [Epub ahead of print]
5. Khan SA, Everest P, Servos S, Foxwell N, Zähringer U, Brade H, Rietschel ET, Dougan G, Charles IG, Maskell DJ (1998) A lethal role for lipid A in *Salmonella* infections. *Mol Microbiol J* 29:571–579
6. Goñi F, Prelli F, Schreiber F, Scholtzova H, Chung E, Kacsak R, Brown DR, Sigurdsson EM, Chabalgoity JA, Wisniewski T (2008) High titers of mucosal and systemic anti-PrP antibodies abrogate oral prion infection in mucosal-vaccinated mice. *Neuroscience* 153:679–686
7. Li Y, Wang S, Scarpellini G, Gunn B, Xin W, Wanda SY, Roland KL, Curtiss R 3rd et al (2009) Evaluation of new generation *Salmonella enterica* serovar Typhimurium vaccines with regulated delayed attenuation to induce immune responses against PspA. *Proc Natl Acad Sci U S A* 106:593–598
8. Cazorla SI, Becker PD, Frank FM, Ebensen T, Sartori MJ, Corral RS, Malchiodi EL, Guzmán CA (2008) Oral vaccination with *Salmonella enterica* as a cruzipain-DNA delivery system confers protective immunity against *Trypanosoma cruzi*. *Infect Immun* 76:324–333
9. Cazorla SI, Matos MN, Cerny N, Ramirez C, Alberti AS, Bivona AE, Morales C, Guzmán CA, Malchiodi EL (2015) Oral multicomponent DNA vaccine delivered by attenuated *Salmonella* elicited immunoprotection against American trypanosomiasis. *J Infect Dis* 211(5):698–707
10. Tartz S, Rüssmann H, Kamanova J, Sebo P, Sturm A, Heussler V, Fleischer B, Jacobs T (2008) Complete protection against *P. berghei* malaria upon heterologous prime/boost immunization against circumsporozoite protein employing *Salmonella* type III secretion system and *Bordetella* adenylate cyclase toxoid. *Vaccine* 26:5935–5943
11. Matos MN, Cazorla SI, Bivona AE, Morales C, Guzmán CA, Malchiodi EL (2014) Tc52 amino-terminal-domain DNA carried by attenuated *Salmonella enterica* serovar Typhimurium induces protection against a *Trypanosoma cruzi* lethal challenge. *Infect Immun* 82:4265–4275
12. Kochetkova I, Trunkle T, Callis G, Pascual DW (2008) Vaccination without autoantigen protects against collagen II-induced arthritis via immune deviation and regulatory T cells. *J Immunol* 181:2741–2752
13. Ochoa-Repáraz J, Rynda A, Ascón MA, Yang X, Kochetkova I, Riccardi C, Callis G, Trunkle T, Pascual DW (2008) IL-13 production by

regulatory T cells protects against experimental autoimmune encephalomyelitis independently of autoantigen. *J Immunol* 181:954–968

14. Flores-Langarica A, Marshall JL, Hitchcock J, Cook C, Jobanputra J, Bobat S, Ross EA, Coughlan RE, Henderson IR, Uematsu S, Akira S, Cunningham AF (2012) Systemic flagellin immunization stimulates mucosal CD103+ dendritic cells and drives Foxp3+ regulatory T cell and IgA responses in the mesenteric lymph node. *J Immunol* 189:5745–5754
15. Schnapp AR, Eickhoff CS, Sizemore D, Curtiss R 3rd, Hoft DF (2002) Cruzipain induces both mucosal and systemic protection against *Trypanosoma cruzi* in mice. *Infect Immun* 70:5065–5074

Poly- ϵ -caprolactone/Chitosan and Chitosan Particles: Two Recombinant Antigen Delivery Systems for Intranasal Vaccination

Sandra Jesus, Edna Soares, and Olga Borges

1 Introduction

Mucosal surfaces, such as gastrointestinal tract, nasal and vaginal tract are the main entrance of some of the pathogenic microorganisms in the host. The easiest and most effective way to induce mucosal immune response in a particular tract, where secretory IgA (sIgA) is the main player, is to administer the vaccine through the same mucosal surface. Despite the existence of the common mucosal immune system, sIgA can be detected simultaneously in diverse mucosae. In particular, intranasal vaccination, in addition to the induction of antigen-specific serum IgG, normally induces good antigen-dose dependent sIgA titers, not only on nasal mucosa, but also on pulmonary and vaginal mucosae [1]. This feature constitutes an important advantage when compared with injectable vaccines. Other benefits of intranasal vaccine formulations include self-administrable opportunity and non-necessity of having sterile vaccine formulations. Nevertheless, the success of intranasal administration of vaccines is dependent on having good mucosal adjuvants, those that are able to activate innate immune system and a formulation that minimizes the effect of the mucociliary clearance and enzymatic degradation of antigens.

1.1 Design of Polymeric Delivery Systems

Among diverse strategies, mucoadhesive/biodegradable polymers are considered promising candidates to prepare microparticles or nanoparticles as antigen delivery systems.

1.1.1 Chitosan Nanoparticles

In particular, significant results have been obtained with chitosan, a mucoadhesive biodegradable polymer, recognized as a good

adjuvant for mucosal surfaces. Despite the great effort made by adjuvant research groups, the mechanism of adjuvanticity is currently not completely understood. The diverse and sometimes opposite results produced do not allow drawing final conclusions since chitosan used in these studies may have different characteristics, like the molecular weight (MW) and deacetylation degree (DD). In fact, chitosan is a generic name for a wide family of biopolymers based on randomly distributed β -(1-4)-linked N-acetyl-d-glucosamine and d-glucosamine obtained by deacetylation of chitin from diverse sources like exoskeleton of crabs, shrimp, and fungi. One of the problems during generation of chitosan includes poor polymer characterization and possible contamination of the chitosan with other compounds, including lipopolysaccharides (LPS) [2]. In our laboratory we found that our chitosan batch (see Subheading 2) either, in solution or nanoparticle form, after a purification process (negative to LAL test), was able, in a dose-dependent manner and in a presence of CpGODN, to induce the production of IL-1 β by mice bone marrow derived dendritic cells (BMDC) by a NLRP3 inflammasome activation dependent mechanism and, contrary to other published reports, in the concentrations tested in our laboratory, do not increase the production of TNF- α by same cells. We also found that chitosan nanoparticles are able to induce the production of β -hexosaminidase [3] by mast cells (HMC-1 cell line) which is a signal of mast cell activation. Finally, robust evidences obtained in our laboratory support the conclusion that chitosan nanoparticle-based formulations perform equally (subcutaneous) or even better (intranasal) than well know adjuvants like alum, present in commercial vaccines.

There are several methods to prepare chitosan particles. There is substantial literature available to generate chitosan particles published since the last 20 years. Among them, ionic gelation technique has attracted considerable attention. The method is based on the property that in acidic medium, primary amine groups of chitosan become protonated and easily interact with small anionic molecules, such as tripolyphosphate (TPP), citrate or sulfate ions. The nanohydrogels obtained by this method result from inter and intra-crosslink ionic interactions. The advantage of the ionic gelation technique is that it is a simple and fast method, easily controllable and organic solvent free. Therefore, the method is adequate to encapsulate biomolecules like proteins or DNA which could be destroyed by organic solvents or by strong shear stress, two conditions used in several particle preparation methods. In opposition to the use of chemical cross-linking agents like glutaraldehyde, that confers a certain toxicity degree to the particles, the physical cross-linking method with the polyanion produce particles with less cytotoxicity. However, the physical stability of chitosan/polyanion particles is poor and thus particles are normally prepared immediately before to be used in both, in vitro and in vivo assays. Otherwise, the use of chemical crosslinkers or

the design of polymeric nanoparticles with more than one polymer, in addition to display particle additional properties, has been described as an attempt to obtain better particle stability. For example, the association of chitosan to poly- ϵ -caprolactone nanoparticles, theoretically, confers to these particles the properties of chitosan, like mucoadhesivity and immunostimulatory effects and inherits from the pure PCL particles their hydrophobic nature which can be advantageous to adsorb on their surface certain biomolecules like therapeutic proteins, peptides or antigens.

1.1.2 Poly- ϵ -caprolactone/Chitosan Nanoparticles

Poly- ϵ -caprolactone (PCL) is a biocompatible polyester that is widely used in drug delivery applications. It is a highly hydrophobic crystalline polymer that degrades very slowly in the absence of enzymes (in vitro) and presents a low cytotoxicity profile [4]. Different methods have been reported in the literature for the preparation of drug entrapped PCL nanoparticles. Among them, interfacial polymer disposition method is a simple and fast procedure. In this method the polymer is first dissolved in an organic solvent, usually acetone and then poured with stirring into water containing the surfactant. To perform blend nanoparticles a second polymer can be dissolved either in organic solvent or in water. In this chapter we use the chitosan dissolved in diluted acetic acid with the surfactant.

1.2 Antigen Loading

Depending on the preparation method, antigens can either be entrapped in the polymer matrix or bound to particle surface by adsorption (Fig. 1). In the first case the incorporation of the antigens into the particle matrix is performed during particle preparation and it implies that high shear forces or organic solvents, conditions that could decrease the bioactivity of the antigens, are not part of the preparation method. The chitosan nanoparticle preparation methods satisfy with this indication but the chitosan/PCL nanoparticle methods do not. Whereas, the adsorption of the antigens to preformed nanoparticles is simple, normally made with a gentle agitation of the particle suspension containing the antigen previously solubilized in water or in a buffer. The success to obtain antigen adsorption depends on antigen-nanoparticle interaction. Particularly, electrostatic interactions, hydrophobic interaction, and specific chemical interaction between the protein and the nanoparticle play important roles [5]. In this chapter, two kinds of nanoparticles are described and the interactions between protein (antigens) and nanoparticles are different since polymer-based nanoparticles, chitosan and poly- ϵ -caprolactone/chitosan have different degrees of hydrophobicity. Chitosan is a hydrophilic polymer and the interactions between chitosan nanoparticles and the antigens are mainly electrostatic. Therefore, in the present case, isoelectric point (IEP) of the protein, ionic strength and pH of the buffer are extremely important in order to obtain a high adsorption efficacy. By contrast, the same factors are less important in the

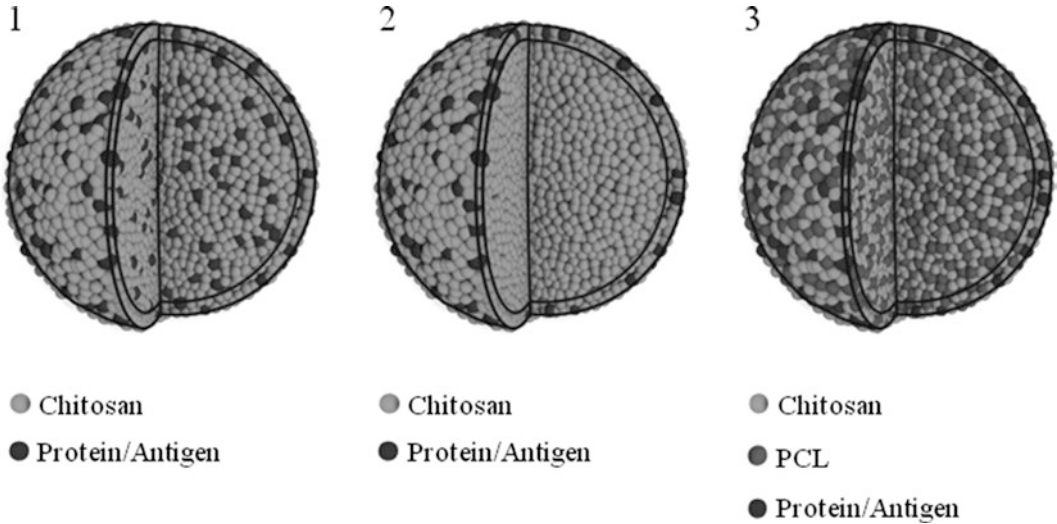

Fig. 1 Schematic representation of antigen location at the two described nanoparticle types. (1) Encapsulation of the antigen—antigen is distributed in the chitosan matrix. (2) Adsorption of the antigen—antigen is located on the surface of chitosan particles. (3) Adsorption of the antigen—antigen is located on the surface of blend (PCL/chitosan) nanoparticles

case of poly-ε-caprolactone/chitosan nanoparticles since protein-nanoparticle interaction is predominantly hydrophobic.

1.3 Mucoadhesivity Assessment

Mucoadhesive particulate adjuvants should be able to increase the residence time of antigens in nasal cavity. This feature would increase antigen loaded particle probability of being taken up by NALT cells and most probably the intensity and quality of the immune response. Therefore the nanoparticle mucoadhesivity is an important quality attribute that can be evaluated. The method described in this chapter is slightly modified compared to the references [6–9]. Briefly, mucin is placed in contact with particles. In subsequent step, particle suspension is centrifuged and the free mucin assessed using periodic acid:Schiff (PAS) colorimetric method.

1.4 Nasal Administration

Taking into account the relative small size of the mouse nose, the volumes administered should range between 4 μL and 10 μL per nostril. Large volumes may not be technically easy to administer without any formulation pass to the stomach or to the lungs. A second critical point to consider during the administration is using a good mouse restrainer to immobilize the head of the mouse to place the formulation in the nostrils. These steps are critical and would influence the results.

1.5 Biological Sampling

The evaluation of the immune response generated by vaccine formulation is performed throughout the experiment. Blood samples and mucosal secretions are collected periodically and

analyzed. Exceptions are nasal secretion and spleen cells which are only collected at the end of the experiment. Although IgA constitutes only 10 % to 15 % of the total serum immunoglobulin, it is the predominant immunoglobulin class in external secretions such as from the nasopharynx, genitourinary and digestive tracts. Serum immunoglobulin transudation into mucosal associated lymphoid tissues has been investigated. This feature has been associated with serum IgG, however serum IgA seems to be able to experience same phenomenon too, although to a lesser extent [10].

2 Materials

2.1 Preparation of Polymeric Delivery Systems

2.1.1 Chitosan Nanoparticles

1. ChitoClear™: chitosan with 95 % DD and 8 mPa s viscosity (e.g., Primex Biochemicals AS, Avaldsnes, Norway) (*see Note 1*).
2. Sodium acetate buffer solution (AcB); 25 mM; pH 5.0: Weigh 1.36 g of sodium acetate anhydrous. Add deionized water to a final volume of 1 L. Adjust the pH to 5.0 with 1 M acetic acid solution.
3. 0.625 % (w/v) sodium sulfate aqueous solution.
4. 15 mL centrifuge tubes.
5. Vortex (e.g., Vortex Mixer, Labnet).
6. Centrifuge (e.g., Sigma 3K15, Rotor 11133).

2.1.2 PCL/Chitosan Nanoparticles

1. ChitoClear™: chitosan with 95 % DD and 8 mPa s viscosity (e.g., Primex Biochemicals AS, Avaldsnes, Norway) (*see Note 1*).
2. PCL (average MW 14,000) (e.g., Sigma-Aldrich Corporation, St Louis, MO, USA).
3. Aqueous solution of 1 % acetic acid (v/v) with 5 % Tween 80™ (w/v).
4. Acetone (Analytical grade).
5. Beaker stand.
6. 50 mL beaker.
7. High speed homogenizer with a 7 mm probe.
8. Magnetic stirrer and magnetic stir bar.
9. Glycerol (Analytical grade).
10. Beckman J-26 XPI centrifuge with JA 25.50 rotor and 50 mL centrifuge tubes (e.g., Oak Ridge, Nalgene®, 50 mL PPCO tubes with PP screw closure).
11. Disposable Pasteur pipette.
12. 2 L beaker and dialysis clamps.
13. Spectra/Por® cellulose ester dialysis membrane, MWCO 300,000 (Spectrum Laboratories, Inc., CA, USA).

2.2 Antigen Loading

1. Recombinant antigen (e.g., recombinant hepatitis B surface antigen (rHBsAg) adw, Aldevron or other recombinant proteins).
2. Sodium acetate buffer solution (AcB); 25 mM; pH 5.0: Weigh 1.36 g of sodium acetate anhydrous. Add deionized water to a final volume of 1 L. Adjust the pH to 5.0 with 1 M acetic acid solution.

2.3 Mucoadhesivity Assessment

1. Mucin from porcine stomach Type III (e.g., Sigma-Aldrich Corporation, St Louis, MO, USA).
2. Schiff reagent: Add 500 mg of basic fuchsin (Pararosaniline) to 80 mL of water and heat until dissolution (≈ 80 °C). When temperature decreases to 50 °C add 10 mL of HCl (1 M). Make up to 100 mL with deionized water and let it cool to room temperature. Add 0.1 g of sodium metabisulfite to every 6 mL of the previous solution incubated at 37 °C until the Schiff reagent becomes pale yellow (several hours).
3. Periodic acid reagent: Add 0.14 mL of 50 % (w/v) periodic acid solution to 10 mL of 7 % (v/v) acetic acid solution.
4. UV-visible spectrometer.
5. Disposable plastic cuvettes.

2.4 Nasal Administration

1. Isoflurane.
2. Low volume micropipette.
3. Mice (*see Note 2*).

2.5 Biological Sampling

1. Anesthetic saturation chamber.
2. Isoflurane.
3. Goldenrod animal lancets (e.g., 5 mm point length for 2–6 month old mice).
4. 1.5 mL centrifuge tubes.
5. Centrifuge (e.g., Sigma 3K15, rotor 12154H).
6. Phosphate Buffer Saline (PBS): add 8 g of sodium chloride, 1.44 g of sodium phosphate dibasic, 0.24 g of potassium dihydrogen phosphate and 0.2 g of potassium chloride to 1 L of deionized water. Mix and adjust the pH to 7.4 with HCl or with NaOH. Sterilize by autoclave. Store at 4 °C.
7. 100 mM phenylmethanesulfonyl fluoride (PMSF) stock solution: add 87.1 mg of PMSF to 5 mL of absolute ethanol. Stable between 2 and 8 °C for at least 9 months.
8. 1 % sodium azide stock solution: add 0.01 g of sodium azide to 1 mL of deionized water. Store at 4 °C.
9. Mice (*see Note 2*).

3 Methods

3.1 Preparation of Polymeric Delivery Systems (Fig. 2)

3.1.1 Chitosan Nanoparticles

1. Dissolve chitosan in AcB (pH 5.0) to a final concentration of 0.1 % (w/v) (*see Note 3*).
2. Place 2 mL of chitosan in AcB solution in a 15 mL centrifuge tube.
3. Under high speed vortexing, add dropwise 2 mL of the sodium sulfate solution to the same tube.
4. Let the nanoparticles formed mature 1 h at room temperature (*see Note 4*).
5. Centrifuge 25 min at $4500 \times g$.
6. Discard the supernatant.
7. Resuspend the resultant pellet in 2 mL of deionized water.

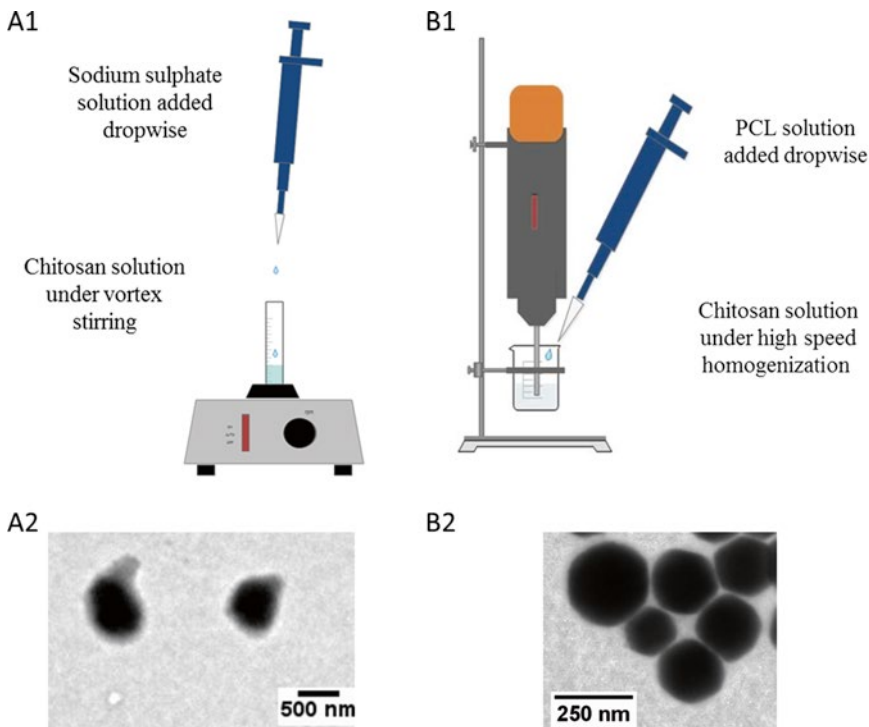

Fig. 2 Schematic overview of the experimental setup used to produce nanoparticles and outcome. **(A1)** Chitosan nanoparticles. **(A2)** Transmission electron microscopy (TEM) photo of freeze-dried chitosan nanoparticles after resuspension in water. **(B1)** PCL/chitosan nanoparticles. **(B2)** TEM photo of freeze-dried PCL/chitosan nanoparticles after resuspension in water

8. Repeat **steps 5** and **6** to completely remove exceeding compounds.
9. Resuspend in the desired volume of deionized water or other suitable buffer for further steps (*see Note 5*).
10. After nanoparticle preparation some parameters should be monitored to guarantee successful execution and reproducibility (*see Note 6*).

3.1.2 PCL/Chitosan Nanoparticles

1. Prepare a 0.2 % (w/v) PCL solution in acetone (*see Note 7*).
2. Prepare a 0.1 % (w/v) chitosan solution in diluted acetic acid (with Tween) (*see Note 8*).
3. Place the high speed homogenizer probe into a beaker containing 13.5 mL of chitosan aqueous solution.
4. Start the high speed homogenization and add 4.5 mL PCL solution dropwise. Keep the homogenization for 1 min more after complete PCL solution addition.
5. Remove the suspension from the beaker holder and introduce a magnetic stirrer bar for additional 45 min magnetic stirring.
6. To concentrate the delivery system, slowly add the resulting 18 mL nanoparticle suspension to a centrifuge tube with a 200 μ L glycerol bed. Centrifuge at $16,000 \times g$ for 75 min at 4 °C.
7. Carefully remove the tube from the centrifuge rotor and with a Pasteur pipette aspirate the supernatant without disturbing the high concentrated nanoparticle layer on the bottom of the tube.
8. To remove the glycerol and other remaining constituents from the nanoparticle concentrate perform a 48 h dialysis against water. Follow the dialysis membrane manufacturer washing instructions before filling it with the suspension. Fill the dialysis membrane, clamp the both ends, and place it in a 2 L water beaker under magnetic stirring. Change the dialysis water twice during the 48 h.
9. Considering the final application dilute the suspension with deionized water or other suitable buffer, or concentrate the particles by centrifuging at $21,000 \times g$ for 15 min.
10. After nanoparticle preparation some parameters should be monitored to guarantee successful execution and reproducibility (*see Notes 5* and **6**).

3.2 Antigen Loading

3.2.1 Encapsulation—Chitosan Nanoparticles

1. Perform the method described in Subheading **3.1** with a slight modification. Add the desired amount of the recombinant antigen to the sodium sulfate solution (e.g., considering a yield of 3.2 mg chitosan nanoparticles per batch, the encapsulation of 80 μ g of the hepatitis B surface antigen (HBsAg) would allow a vnasal administration of eight mice that corresponds to 10 μ g HBsAg loaded into 400 μ g of nanoparticles per animal).

2. Use the supernatant discarded in **step 6** described in Subheading **3.1**—chitosan nanoparticles, to determine the antigen loading efficacy of the recombinant antigen used (*see* **Notes 9** and **10**).
3. After washes resuspend in AcB for further nasal administration (e.g., 120 μ L for eight animals, 15 μ L per animal) (*see* **Note 11**).

3.2.2 Adsorption— Chitosan and PCL/Chitosan Nanoparticles

1. Perform either methods described in Subheading **3.1**—chitosan nanoparticles or—PCL/chitosan nanoparticles, depending of which delivery system you wish to adsorb the recombinant antigen and start the adsorption having the nanoparticles concentrated in pellet.
2. Add recombinant antigen solution (AcB pH 5.0 or other) to the nanoparticle pellet at room temperature and incubate (e.g., in a rotor mixer) for 30 min (e.g., for chitosan nanoparticles, considering a pellet of 3.2 mg, add 80 μ g of HBsAg suspended in 120 μ L AcB for a total of 8 animals: 15 μ L per animal containing 400 μ g of nanoparticles and 10 μ g of HBsAg; for PCL/chitosan nanoparticles considering a pellet of 10 mg, in order to immunize eight animals each with 400 μ g nanoparticles and 10 μ g HBsAg, the pellet can be resuspended in 100 μ L AcB, use 32 μ L of the resulting suspension and mix with 80 μ g HBsAg in 88 μ L AcB) (*see* **Notes 5** and **10–12**).

3.3 Mucoadhesivity Assessment

1. Incubate 1 mg of nanoparticles with mucin at several different concentrations (50–400 μ g/mL) to a final volume of 1 mL (samples).
2. Prepare 1 mL mucin standards in water (from 0 to 250 μ g/mL).
3. Incubate the samples and the standards under agitation (e.g., rotational) at room temperature for 60 min.
4. Centrifuge the samples and the standards at $21,460\times g$ for 15 min and collect 900 μ L of each supernatant.
5. Add 90 μ L of the periodic acid to each 900 μ L of supernatant and incubate for 75 min at 37 $^{\circ}$ C.
6. Add 90 μ L of Schiff reagent and incubate for 30 min at room temperature.
7. Transfer the solution to a disposable plastic cuvette and read the optical density (OD) at 550 nm (*see* **Note 13**).
8. Built a calibration curve with the ODs obtained for mucin standards vs standard mucin concentrations.
9. Calculate the free mucin present in the supernatants interpolating the ODs obtained for samples in the equation obtained in 8.

10. Calculate the mucin adsorbed onto the nanoparticles surface by subtracting the amount of free mucin from the total mucin content in the test mixture.

$$\text{Adsorbed mucin(\%)} = 100 \times \left(\frac{\text{Total mucin} - \text{free mucin}}{\text{Total mucin}} \right) \quad (1)$$

11. Interpret data using the following equations which describe adsorption isotherms:

Freudlich equation

$$\frac{x}{m} = K \cdot C^{1/n} \quad (2)$$

Langmuir equation

$$\frac{1}{x/m} = a + b \cdot \frac{1}{C} \quad (3)$$

where x/m is mucin adsorbed, K and n are Freudlich isotherms constants, a and b are Langmuir isotherms constants, and C_c is the free mucin (*see Note 14*).

3.4 Nasal Administration

1. Restrain the mouse using double hand method and ensure the mouse is well immobilized (*see Note 15*).
2. With a low volume pre-calibrated micropipette place a drop of the formulation into the mouse nostril and wait for it to be dry. Repeat the procedure alternating from one nostril to the other until the total of 15 μL is administered (*see Note 16*).

3.5 Biological Sampling

3.5.1 Serum

1. Place the mouse in a saturated isoflurane chamber until it loses responsiveness to manipulations and rear foot reflexes.
2. Collect blood from the mandibular vein by venipuncture with an animal lancet to a 1.5 mL microcentrifuge tube (*see Note 17*).
3. Let the blood coagulate over 6 h.
4. Centrifuge for 10 min at $4500 \times g$.
5. Carefully transfer the serum (supernatant) to another tube (do not aspirate the bottom erythrocytes).
6. Store at -20°C until further analysis (*see Note 18*).

3.5.2 Vaginal Washes

1. Restrain the mouse using one hand method.
2. Collect vaginal mucosa using a micropipette by flushing in and out the vagina surface with 100 μL of ice-cold PBS (e.g., 10 flushes per wash) to a 1.5 mL centrifuge tube.

3. Add 1 μL of sodium azide and 1 μL of PMSF stock solutions to each 100 μL of collected vaginal wash (*see Note 19*).
4. Incubate at room temperature for 15 min.
5. Centrifuge for 15 min at $3300\times g$.
6. Collect the supernatant and store at $-80\text{ }^{\circ}\text{C}$ until further analysis (*see Notes 20 and 21*).

3.5.3 Nasal Washes (Fig. 3)

1. Place the mouse in a saturated isoflurane chamber until it loses responsiveness to manipulations and rear foot reflexes.



Fig. 3 Representative photographs of the nasal wash technique performed in order to evaluate mucosal immune response in mice nasal mucosa (described in Subheading 3.5). Steps leading to the collection of the nasal wash are illustrated. (1) After the animal euthanasia the jaw is carefully removed by cutting the mouth sideways until the trachea shows up accessible without disruption. The separated jaw and tongue are transversally cut for better approach. (2) Blood present in the oral cavity is cleaned using PBS and medical compresses or absorbent paper. (3) A small hole in the trachea is done with a 19 G needle in order to further insert a mouse oral gavage needle; (4) The mice is positioned vertically to the collection tube, while the mouse oral gavage needle is inserted cautiously in the animal trachea. PBS is then flushed through the needle, passing the mice nasal cavity and collected at nostrils into the collection tube

2. Euthanize the mice by cervical dislocation.
3. Carefully remove the jaw, cutting the mouth sideways until the trachea shows up accessible without disruption.
4. Clean the open cavity with some cold PBS and soak it with medical compresses (*see Note 22*).
5. Use a 19 G needle to make a hole in the trachea.
6. Insert a mouse oral gavage needle in the hole previously made.
7. Flush 200 μL of PBS into the trachea collecting the outcoming wash fluid through the nose to a 1.5 mL centrifuge tube.
8. Add 2 μL of sodium azide and 2 μL of PMSF stock solutions to each 200 μL nasal wash.
9. Incubate at room temperature for 15 min.
10. Centrifuge for 20 min at $15,700\times g$.
11. Collect the supernatant and store at $-80\text{ }^{\circ}\text{C}$ until further analysis (*see Notes 20 and 21*).

4 Notes

1. The viscosity of 1 % chitosan in 1 % acetic acid solution was measured by the supplier. The value of 8 mPa s corresponds to a low molecular weight (LMW) chitosan. Chitosan from other sources can be used; however, make sure to follow the exact protocol described in this chapter and the characteristics (DD and LMW) of chitosan have to be similar. Slight differences in properties of chitosan by different manufacturers may be the reason that it is difficult to reproduce the methods involving chitosan [11–13]. Besides commercial differences, chitosan may be further purified to remove contaminants and endotoxins by a technique already described by us [14]. Nevertheless, after this process it is important to evaluate the resulting polymer in order to verify if its characteristics were altered.
2. If you intend to evaluate vaginal mucosal immunity following a nasal administration of a recombinant antigen you need to acquire female mice. C57BL/6J and BALB/c are animal models widely used for immunology studies.
3. Chitosan suffers from a poor solubility in water or in organic solvents. Charge density depends on the degree of acetylation and pH [12]. Chitosan is readily soluble in dilute acidic solutions below pH 6.0 because it possesses primary amino groups with a pK_a value of 6.3 [15], which is the case of AcB (pH 5.0) used in the present work. Chitosan takes more than 4 h to solubilize by magnetic stirring at room temperature.
4. Laboratory temperature should be carefully monitored during the preparation of the nanoparticles for reproducibility.

For temperatures higher than 20 °C the particles normally aggregate.

5. In this phase of the preparation process, nanoparticle yield can be estimated. To calculate the mass of nanoparticles obtained, do not resuspend the particles in buffer and instead the pellet can be freeze-dry and weighed. Nanoparticle yield is an important data to predict the number of batches that could be produced for a particular experiment.
6. To validate the preparation method with a new chitosan batch, size and zeta potential of the particles should be measured. Dynamic light scattering and electrophoretic light scattering methods can be used with this aim (e.g., Delsa™ Nano C particle analyzer, at 25 °C and 165° angle). Nanoparticles can be suspended in water or any other suitable buffer according to their final use. Please note that all measurements should be performed at same concentration and in the same buffer for direct comparison between delivery systems, as buffer pH and ionic strength might change nanoparticle surface charge and hydrodynamic size [16] (e.g., zeta potential should be measured in sodium acetate buffer pH 5.0 if the nasal administration will be performed in the same buffer for a more realistic characterization). In fact, for PCL/chitosan nanoparticles zeta potential is highly influenced by the diluent used. When they are suspended in acetate buffer their zeta potential is neutral, but when suspended in water, values around +25 mV are observed.
7. PCL solubility depends on the organic solvent chosen (e.g., high solubility in chloroform, low solubility in acetone, and no solubility in diethyl ether) [17, 18]. To achieve total solubilization in acetone you may warm the solution until 45–50 °C and then place it in a rotor mixer. Make sure to properly seal the tube cap with Parafilm® to prevent evaporation because acetone is a volatile solvent. Use the solution only when temperature is around 20 °C.
8. Take into consideration what was mentioned in **Note 3**. In this situation, to dissolve chitosan in the diluted acetic acid solution you will need approximately 2 h with magnetic stirring.
9. The recombinant antigen loading efficacy is affected by several factors including the recombinant antigen isoelectric point (IEP) and pH of the medium. In case of chitosan nanoparticles we have tested the encapsulation of several model proteins with different isoelectric points and observed that using the AcB (pH 5.0), as the solvent, during particle preparation and antigen encapsulation, proteins with a IEP lower than 5.0 (carrying a strong negative surface charge at pH higher than its IEP) present a higher loading efficacy and a slower release

profile, as described by others [19]. On the contrary, at the same loading conditions, recombinant antigens with IEP higher than 5.0 normally present lower loading efficacies. This is explained by the fact that if their isoelectric point is higher than the pH of the encapsulation solution (acetate buffer pH 5.0) the protein is carrying a net positive charge, hindering the interaction with the also positively charged chitosan. For each recombinant antigen, encapsulation conditions (e.g., antigen concentration in sodium sulfate solution) should be optimized. With this aim, a model protein resembling its molecular weight and isoelectric point, can be used due to the high cost of most recombinant antigens. The assessment of the loading efficacy (*see Note 10*) will help you optimize the protocol so that all antigens added stay encapsulated and nothing is wasted.

10. Recombinant antigen/protein loading efficacy (LE) or loading capacity (LC) is calculated by an indirect way, quantifying the unbound protein remaining in the supernatant. Recombinant antigen/protein concentration can be determined using a BCA protein assay kit for general protein quantification (be aware of possible interferences) or an antigen-specific ELISA (e.g., HBsAg ELISA Kit). The loading percentages are obtained using the following equations:

Loading efficacy

$$LE(\%) = \left(\frac{\text{Total protein} - \text{Unbound protein}}{\text{Total protein}} \right) \times 100 \quad (4)$$

Loading capacity

$$LC(\%) = \left(\frac{\text{Total protein} - \text{Unbound protein}}{\text{Total nanoparticles}} \right) \times 100 \quad (5)$$

For recombinant protein encapsulation in chitosan nanoparticles, the unbound protein is measured in the supernatants resulting from **step 6** (*see Subheading 3.2*). For adsorbed recombinant protein in chitosan nanoparticles or in PCL/chitosan nanoparticles, the unbound protein is measured in supernatants obtained by centrifugation of the final formulations for 25 min at $4500 \times g$, or for 15 min at $21,000 \times g$, respectively.

11. Particularly for chitosan nanoparticles, highly concentrated suspensions may have an increased viscosity that makes it difficult to use during pipetting and intranasal administration of the formulation.
12. Recombinant antigen adsorption on both chitosan and PCL/chitosan nanoparticles is based on electrostatic interactions and is affected by the same factors referred to in **Note 9**. Regarding

PCL/chitosan nanoparticles, hydrophobic interactions between PCL and protein occur and may be the main forces involved. Antigen loading efficacy should be assessed using a model protein resembling its molecular weight and isoelectric point, regarding the high cost of most recombinant antigens. This will help you to choose the adsorption conditions that result in the best loading efficacy and to predict the amount of antigen that will be administered free or bound to the nanoparticles since in this method, unbound antigen should not be separated from the formulation that will be administered to mice.

13. The colorimetric method described here was first developed for glycoprotein quantification by Mantle and Alan [6]. Once the method is based in the oxidation of mucin glycols into aldehydes by periodic acid and further reaction of these groups with Schiff reagent, caution must be taken concerning interferences. When analyzing supernatants for mucin unable to bind the nanoparticles, interferences from nanoparticles may also be present. Therefore it is advisable to perform the same test without mucin in order to evaluate method interferences. In fact, PCL/chitosan nanoparticles blanks supernatants (without mucin) generate high ODs that must be subtracted from the mucin containing sample ODs.
14. In order to better analyze mucoadhesion of polymeric nanoparticles Freundlich and Langmuir isotherms may be calculated. The goodness of the linear regressions fitting obtained are the parameter used to estimate which isotherm better fits each delivery system. Langmuir equation represents a monolayer limited adsorption isotherm for a finite number of sites, while Freundlich equation fits the adsorption to a heterogeneous surface supporting sites with varied affinities [20].
15. If some difficulties are encountered during the immobilization process anesthetizing the animals may be a solution. Place the mice in a saturated isoflurane chamber until it lose responsiveness to manipulation and foot reflexes which may simplify the subsequent nasal administration process. Nevertheless, caution should be made once volatile anesthesia may interfere with some experiments. The advantages and disadvantages of using anesthetics may be considered for specific experiments.
16. Formulation volume to deposit in each mouse nostril should be as smaller as possible. However, issues like high viscosity of very concentrated suspensions or even the inability to obtain higher concentration formulations, implicate the administration of greater volumes (until 10 μ L per nostril). Other factors may also be relevant for the administered volume. For PCL/chitosan nanoparticles to present a positive zeta potential when adsorbed with protein, a higher nanoparticles–antigen ratio than 40:1 (as exemplified) should be used, as well as the diluent

should be preferably water. This positive zeta potential would be beneficial for the nasal administration, but presents difficulties to obtain. We quadruplicated the amount of nanoparticles for the same amount of antigen (ratio 160:1, in water) and we reached weak positive zeta potentials. As increasing nanoparticle concentration was not viable, diminishing the amount of antigen in this formulation (e.g., 160:0.5 and 160:0.15) resulted in more positive zeta potential values. With this we pretend to exemplify a situation, where if no more concentrated particles may be obtained, a reduction in the antigen ratio may increase the zeta potential and an increased volume may be considered per mouse, to give an optimal antigen dose.

17. In our laboratory we perform a single blood draw, repeated multiple times with 2-week interval to monitor the systemic immune response over time. We usually collect about 2–3 drops (about 150 μ L of blood) representing 10 % of circulating blood volume of a 6–8 week old mice, which is the sample volume recommended for this sampling frequency (NIH Guidelines for Survival Bleeding of Mice and Rats).
18. Antigen-specific immunoglobulins (IgG, IgM, IgE, and IgA) are frequently analyzed on serum samples. It is also possible to analyze IgG subtypes to explore the Th1/Th2 immune response profile.
19. Sodium azide can interfere with some ELISA antibody measurements. However, we tested that possibility and we found that in the concentrations used in each sample, it does not interfere using the Mouse IgA ELISA Quantitation Kit (Bethyl Laboratories).
20. Cytokines and interleukins should be ideally stored at -80°C , but they can also be stored at -20°C for a maximum of 6 months.
21. Mucosal samples in the case of nasal vaccination are of extreme importance. One of the advantages in nasal immunization is the possibility to induce mucosal antibodies, particularly specific secretory IgA. Nevertheless, sample collection has conditioned reproducibility leading to variability between animals. Instead of only analyzing specific IgA, normalization may be performed with the total IgA present in the sample. For nasal samples 200 μ L is enough for both immunoglobulin ELISA measurements, using 80 μ L concentrated sample for each. For vaginal washes, a pool of two consecutive sampling days may be a solution to achieve enough volume for analysis.
22. It is important to ensure a blood free cavity (from trachea to nose) for an optimal nasal wash. Results from samples contaminated with blood may be misleading since antibodies detected may be from blood source.

References

1. Holmgren J, Czerkinsky C (2005) Mucosal immunity and vaccines. *Nat Med* 11:S45–S53
2. Vasiliev YM (2015) Chitosan-based vaccine adjuvants: incomplete characterization complicates preclinical and clinical evaluation. *Expert Rev Vaccines* 14:37–53
3. Bento D, Staats HF, Goncalves T, Borges O (2015) Development of a novel adjuvanted nasal vaccine: C48/80 associated with chitosan nanoparticles as a path to enhance mucosal immunity. *Eur J Pharm Biopharm* 93:149–164
4. Chawla JS, Amiji MM (2002) Biodegradable poly(epsilon-caprolactone) nanoparticles for tumor-targeted delivery of tamoxifen. *Int J Pharm* 249:127–138
5. Lynch I, Dawson KA (2008) Protein-nanoparticle interactions. *Nanotoday* 3:40–47
6. Mantle M, Allen A (1978) A colorimetric assay for glycoproteins based on the periodic acid/Schiff stain [proceedings]. *Biochem Soc Trans* 6:607–609
7. Pawar D, Mangal S, Goswami R, Jaganathan KS (2013) Development and characterization of surface modified PLGA nanoparticles for nasal vaccine delivery: effect of mucoadhesive coating on antigen uptake and immune adjuvant activity. *Eur J Pharm Biopharm* 85(3 Pt A):550–559
8. Dhawan S, Singla AK, Sinha VR (2004) Evaluation of mucoadhesive properties of chitosan microspheres prepared by different methods. *AAPS PharmSciTech* 5(4), e67
9. Martinac A, Filipovic-Grcic J, Voinovich D, Perissutti B, Franceschinis E (2005) Development and bioadhesive properties of chitosan-ethylcellulose microspheres for nasal delivery. *Int J Pharm* 291:69–77
10. Meckelein B, Externest D, Schmidt MA, Frey A (2003) Contribution of serum immunoglobulin transudate to the antibody immune status of murine intestinal secretions: influence of different sampling procedures. *Clin Diagn Lab Immunol* 10:831–834
11. Sonia TA, Sharma CP (2011) Chitosan and its derivatives for drug delivery perspective. *Adv Polym Sci* 243:23–53
12. Rinaudo M (2006) Chitin and chitosan: properties and applications. *Prog Polym Sci* 31:603–632
13. Dutta PK, Dutta J, Tripathi VS (2004) Chitin and chitosan: chemistry, properties and applications. *J Sci Ind Res* 63:20–31
14. Jesus S, Borchard G, Borges O (2013) Freeze dried chitosan/poly-e-caprolactone and poly-e-caprolactone nanoparticles: evaluation of their potential as DNA and antigen delivery systems. *J Genet Syndr Gene Ther* 4:164
15. Pillai CKS, Paul W, Sharma CP (2009) Chitin and chitosan polymers: chemistry, solubility and fiber formation. *Prog Polym Sci* 34: 641–678
16. Jiang J, Oberdörster G, Biswas P (2009) Characterization of size, surface charge, and agglomeration state of nanoparticle dispersions for toxicological studies. *J Nanoparticle Res* 11:77–89
17. Sinha VR, Bansal K, Kaushik R, Kumria R, Trehan A (2004) Poly-epsilon-caprolactone microspheres and nanospheres: an overview. *Int J Pharm* 278:1–23
18. Labet M, Thielemans W (2009) Synthesis of polycaprolactone: a review. *Chem Soc Rev* 38:3484–3504
19. Koppolu BP et al (2014) Controlling chitosan-based encapsulation for protein and vaccine delivery. *Biomaterials* 35:4382–4389
20. Chuah LH, Billa N, Roberts CJ, Burley JC, Manickam S (2013) Curcumin-containing chitosan nanoparticles as a potential mucoadhesive delivery system to the colon. *Pharm Dev Technol* 18:591–599

Micro-fractional Epidermal Powder Delivery for Skin Vaccination

Feng Jia, Shengwu Liu, Mei X. Wu, and Xinyuan Chen

1 Introduction

Vaccination plays a crucial role in global public health. Currently most vaccines are delivered into the muscular tissue, whereas smallpox vaccine, the first successful vaccine in human history was delivered into the skin by scarification [1]. In pursuit of a more potent immune response, there was a renewed interest in exploitation of skin vaccination in the last two decades considering that the skin but not the muscle contains large amounts of antigen-presenting cells [2, 3]. Rabies vaccine is now recommended for intradermal (ID) delivery to address vaccine shortage. Similarly, seasonal influenza vaccine has been approved for ID delivery to save vaccine dose and cost [4–8]. Besides dose sparing, there are also efforts in exploitation of ID delivery to improve vaccine efficacy in the elderly, in which vaccines often induce inferior immune responses due to age-related immunosenescence [9–11].

Despite an improved vaccine immunogenicity, broad application of ID vaccination in the clinics is hampered due to the following reasons. (1) ID vaccination is associated with frequent and sometimes severe local reactions. For example, ID rabies vaccine and seasonal influenza vaccine induce higher rates of local reactions, like erythema, pruritus, edema, as compared to intramuscular (IM) vaccination [4, 6]. Severe local reactions, like ulceration, might breach integrity of the skin and increase local infection risk. Local reactions might also cause skin irritation and affect acceptance of ID vaccination in the clinics. (2) ID vaccination only mildly increases vaccine-induced immune response. Incorporation of adjuvants is long sought after to boost vaccine-induced immune response. Yet they also increase risk of local reactions after ID injection [12–15].

Due to these reasons, the current ID vaccination contains no external adjuvants and is only approved for delivery of highly immunogenic vaccines that require no adjuvants to be effective. Novel skin delivery technologies capable of minimizing vaccine/adjuvant-induced local reactions are highly demanded to exploit the full potential of skin vaccination.

We recently developed a novel skin delivery technology, called micro-fractional epidermal powder delivery (EPD), for needle-free, painless skin vaccination with minimized local reactions [16]. EPD is based on laser or microneedle treatment to generate microchannel (MC) arrays in the epidermis followed by topical application of powder vaccine-coated array patches to deliver vaccines into the skin via MCs [16]. EPD can efficiently deliver more than 80 % vaccine and adjuvant dose into the skin within 1 h [16]. Interstitial fluid is assumed to play a crucial role in EPD. After laser or microneedle treatment, interstitial fluid would be drawn into each MC and efficiently dissolve topically applied vaccine/adjuvant powder followed by drainage of dissolved vaccines and adjuvants into each MC via a concentration gradient. Because each MC is surrounded by normal healthy skin with full repairing capacity, EPD largely eases vaccine/adjuvant-induced local reactions and induces a full skin recovery without compromising vaccine immunogenicity and adjuvant potency [16]. In this chapter, model antigen ovalbumin (OVA) is used to describe detailed methods of powder array patch coating and laser-based EPD in the presence or absence of a highly reactive combinatorial lipopolysaccharide (LPS)/CpG adjuvant in murine models.

2 Materials

2.1 Animals and Laser Device

1. BALB/c mice (6–8 weeks, Charles River Laboratories).
2. UltraPulse Fractional CO₂Laser (Lumenis Inc., Yorkneam, Israel).

2.2 Antigen and Adjuvants

1. OVA (Grade V, Sigma, St. Louis, MO).
2. LPS (Sigma, St. Louis, MO).
3. CpG 1826 (5'-TCCATGACGTTTCCTGACGTT-3') with a phosphorothioate backbone synthesized by Trilink Biotechnologies, Inc. (San Diego, CA).

2.3 Patch Components

1. Cover membrane: Transparency film (Staples) sterilized by γ -irradiation before use (*see Note 1*).
2. Adhesive patch: A 3M Tegaderm film is layered on top of a scotch packaging tape (3M) to form a sterile adhesive surface for powder vaccine/adjuvant coating (*see Note 2*).

2.4 Enzyme-Linked Immunosorbent Assay (ELISA) Components

1. ELISA plates: Corning high-binding, clear, flat-bottom, 96-well plates.
2. Phosphate-buffer saline (PBS): 137 mM NaCl, 2.7 mM KCl, 8.1 mM Na₂HPO₄, 1.47 mM KH₂PO₄, pH 7.4. Weigh 8.0 g NaCl, 0.2 g KCl, 1.44 g Na₂HPO₄, 0.24 g KH₂PO₄. Mix and add water to 800 mL. Dissolve and adjust pH to 7.4 with HCl. Make up to 1 L with water. Autoclave and store at 4 °C.
3. Coating buffer: 0.05 M Carbonate-Bicarbonate, pH 9.6. Weigh 1.5 g Na₂CO₃ and 2.93 g NaHCO₃. Mix and add water to 1 L (*see Note 3*).
4. Blocking buffer: 5 % nonfat milk/PBS. Weigh 5.0 g nonfat milk and add 90 mL water to dissolve by stirring. Make up to 100 mL with water.
5. Washing buffer: 0.05 % Tween 20/PBS. Dissolve 0.5 mL Tween 20 in 1 L PBS. Mix and store the buffer at 4 °C.
6. Secondary antibody: horseradish peroxidase (HRP)-conjugated anti-mouse IgG.
7. TMB substrate.
8. Stop solution: 3 M H₂SO₄. Dilute H₂SO₄ with water for 6 times and store diluted H₂SO₄ at room temperature (*see Note 4*).
9. Microplate reader (SpectraMax M5, Molecular Devices).

3 Methods

All procedures of EPD are carried out at room temperature except otherwise specified.

3.1 Fine Powder Preparation (*see Note 5*)

1. Load OVA powder onto the frosted end of one microscope slide (Thermo Scientific) (*see Note 6*).
2. Hold the microscope slide with frosted end facing up.
3. Hold another microscope slide with the frosted end facing down.
4. Crush OVA powder between the frosted ends slowly and repeatedly until no big powder can be seen (*see Note 7*).
5. Collect fine OVA powder into a microcentrifuge tube (*see Note 8*).
Follow the following steps to prepare OVA/LPS/CpG powder
6. Prepare fine LPS and CpG powder as above.
7. Weigh 1 mg OVA, 2 mg LPS, and 2 mg CpG powder or OVA, LPS, CpG powder in the same ratio but different amounts into a microcentrifuge tube.
8. Mix the powder by tapping or vortexing the tube followed by centrifugation to pellet the powder (*see Notes 9 and 10*).

3.2 Powder Array Patch Coating

A cover membrane is exposed to laser to create an array of microholes and then used to generate the same array of coating on an adhesive patch surface. Here 9×9 array in $6 \times 6 \text{ mm}^2$ area is used as an example to explain the detailed patch coating (Fig. 1).

1. A cover membrane is exposed to laser at 35 mJ energy and 5 % skin coverage to generate a 9×9 array of microholes in $6 \times 6 \text{ mm}^2$ area, each with a measured diameter of $\sim 189 \mu\text{m}$ (*see Note 11*).
2. The cover membrane with the 9×9 array of microholes is positioned onto an adhesive patch surface.
3. OVA or OVA/LPS/CpG powder is taken from the eppendorf tube using a stainless steel spoon (Spatula) and pushed into the 9×9 array of microholes with the reverse side of the spoon (*see Note 12*).
4. Repeat until all microholes are fully filled with vaccine powder (*see Note 13*).
5. Excessive non-adherent powder is gently wiped off with Kimwipes (KIMTECH).
6. The cover membrane is peeled off to obtain powder vaccine-coated 9×9 array patches.
7. Cut away excessive edges for quantification of coating amount.

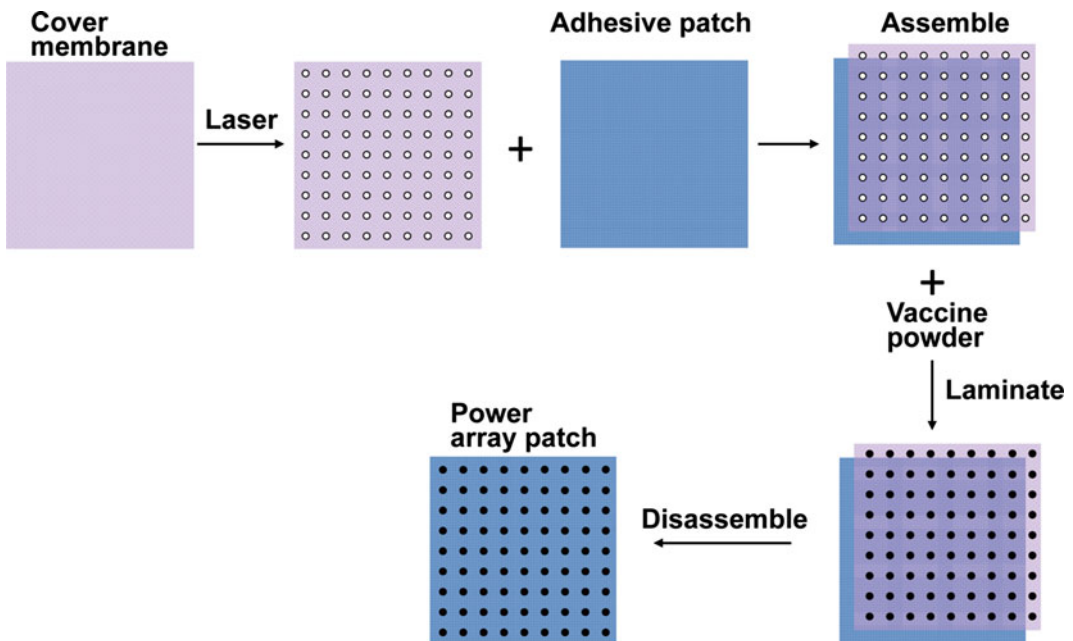

Fig. 1 Illustration of powder array patch coating. A cover membrane is exposed to laser to generate a 9×9 array of microholes and then layered on top of an adhesive patch surface. Vaccine powder is poured onto the membrane/patch assembly and pushed to fill the microholes. Non-adherent powder is removed and the cover membrane is peeled off to obtain powder vaccine coated 9×9 array patches

8. Immerse the patch into 50–100 μL PBS and keep the tube at room temperature for 1 h with intermittent vortexing (*see Note 14*).
9. Collect supernatant and quantify OVA concentration with a bicinchoninic acid (BCA) protein assay (Pierce) (*see Note 15*).
10. Calculate the patch area needed to deliver 10 μg of OVA in the presence or absence of LPS/CpG adjuvant.
11. Extract patch-coated OVA or OVA/LPS/CpG in PBS and prepare for ID injection (*see Notes 16 and 17*).

3.3 In Vivo Delivery

To facilitate the alignment of powder-coated array patches with laser-generated MCs, it's crucial that skin remains in position during and after laser illumination. Here we describe a simple method to prepare a skin immobilizer with readily available materials. A card box with 0.5 mm thickness is cut into a square frame, which has an overall size of $15 \times 15 \text{ mm}^2$ and an edge width of 3 mm as shown in Fig. 2. The square frame is further attached to a double-sided tape to form a skin immobilizer. In this chapter, BALB/c mice are used to depict the in vivo delivery. Animal procedures require prior approval by Institutional Animal Care and Use Committee (IACUC).

1. On day 0, anesthetize mice and remove hair on the lower back skin with an electric shaver followed by a hair removal lotion (Nair) [17].
2. On day 1, anesthetize mice and clean the skin with alcohol (*see Note 18*).
3. Wait ~5 min until skin is completely dried (*see Note 19*).
4. Put the skin immobilizer around the area to be illuminated (*see Note 20*).
5. Illuminate the skin at 5 mJ energy and 5 % skin coverage (*see Note 21*).

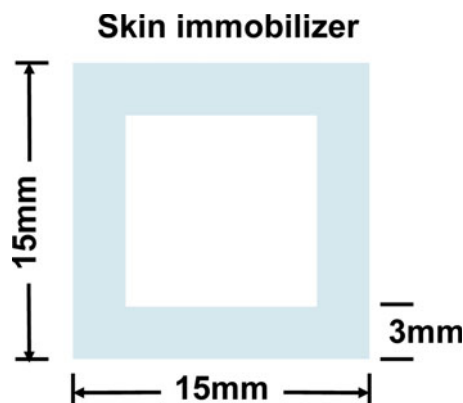

Fig. 2 Dimension of skin immobilizer

6. Grasp one corner of the patch with fine-tipped forceps, hold the patch horizontally and move slowly towards laser-illuminated skin, carefully align coating spots with laser-generated skin MCs, and firmly attach the patch on the skin surface.
7. Carefully remove skin immobilizer without loosening the patch.
8. Allow the mice to recover on a warm pad and remove the patch 6 h later (*see Note 22*).
9. For ID immunization, a 0.5 cc insulin syringe equipped with a 29 G needle (BD) is used to inject ~20 μL patch extracts into the dermal tissue of the skin at the same anatomical location as in EPD (*see Note 23*).
10. Record local skin reactions daily for 2 weeks (*see Note 24*).

3.4 Determine Antibody Titer Using ELISA

1. Collect ~50 μL blood from lateral tail vein 2–3 weeks after immunization. Serum is separated for ELISA analysis.
2. Coat 96-well ELISA plates with 100 μL /well of 100 $\mu\text{g}/\text{mL}$ OVA in coating buffer overnight at 4 $^{\circ}\text{C}$.
3. Wash plates three times with PBS and block plates with 5 % blocking solution at room temperature for 1 h.
4. Wash plates three times with washing buffer and incubate plates with 2-serial dilutions of immune sera in blocking buffer (1:100, 1:200, 1:400, 1:800, 1:1600, 1:3200, 1:6400, 1:12,800) at room temperature for 1.5 h.
5. Wash plates three times with washing buffer and incubate plates with 100 μL /well HRP-conjugated anti-mouse IgG antibody (1:5000 dilution) at room temperature for 1 h.
6. Wash plates three times with washing buffer and incubate plates with 100 μL /well TMB solution at room temperature for 15 min or until sufficient blue color develops.
7. Add 100 μL /well stop solution to stop reaction.
8. Read Absorbance at 450 nm in a microplate reader.
9. Antibody titer is calculated as the dilution factor when OD_{450} reaches around 0.2, which is 3–4 times above the baseline level.

4 Notes

1. Authors can try different materials for use as cover membrane.
2. Authors can explore other types of adhesive patches for powder array patch coating and in vivo delivery.

3. Such a mixing will generate a buffer with pH ~9.6. Thus, there is no need to adjust pH here.
4. Be careful, dilution of concentrated sulfuric acid will release large amounts of heat.
5. To avoid skin and mucous membrane contacts, always wear gloves, lab coat, face mask and eye goggles during fine powder preparation and coating.
6. To avoid moisture, equilibrate lyophilized powder to room temperature before next step.
7. We describes a convenient method based on microscope slide crushing to prepare small-scale fine powder for laboratory use. Other methods, like spray drying and ball milling, can be used to prepare large-scale fine powder for manufacturing use.
8. Fine powder size can be measured by Zetasizer (Malvern Instruments) after suspension in mineral oil.
9. Alternative to powder mixing, OVA, LPS, and CpG solution can be prepared and mixed followed by lyophilization for fine powder preparation and coating.
10. Fine powder can be kept at room temperature in desiccators for a few days or in a refrigerator or freezer in the presence of desiccants for a few weeks.
11. Microhole size in cover membrane can be increased to coat more powder on the patch. Yet this might reduce the delivery efficiency and needs to be explored.
12. Take caution when handling powder at milligram scale because fine powder tends to adhere to tube walls due to the electrostatic force or flow into the air due to turbulent air motion.
13. To minimize powder loss, each time only take a minimal amount of powder for coating.
14. Use only 50–100 μ L PBS for patch extraction to increase the detection limit of BCA assay.
15. A standard solution with OVA, LPS, and CpG at 1, 2 and 2 mg/mL, respectively, will be used to quantify OVA concentration in the presence of LPS/CpG.
16. We recommend preparing the patch 1 day before experiment to allow sufficient time for animal experiments because it takes at least 2–4 h to coat the patch, prepare patch extracts, and quantify the coating amount.
17. We find powder array patches can be stored at room temperature inside desiccators and patch extracts can be kept in a refrigerator for next day use without significant loss of activity. Long-term storage is possible and needs to be explored.
18. Sufficient anesthesia is needed to prevent mouse movement to facilitate the alignment of powder array patches with laser-generated skin MCs.

19. Make sure skin is completely dried before laser illumination because even little water on the skin surface will significantly absorb CO₂ laser energy and affect MC generation. Surface water can also affect powder dissolution and delivery after patch application.
20. Mouse skin can readily change shape or shift position. Thus we recommend putting the mouse on a tray without moving it during EPD. Choose a flat skin and further put a skin immobilizer to keep the skin in position. We find skin immobilizer is not required for EPD in pigs because pig skin is thick and can remain in position without readily movement.
21. The laser parameters we choose induce >80 % delivery efficiency and quick skin recovery in murine models. Researchers can try different laser parameters.
22. Powder array patches can also be removed the next day. In this case, an adhesive bandage can be used to prevent mouse scratching or biting and keep patches in position.
23. To reduce ID injection volume, the same PBS buffer can be used to extract multiple patches.
24. We find local reactions often peak 4–5 days after immunization in mice.

Acknowledgement

This work is supported by the National Institutes of Health grants DA033371 and AI107678 (to X.Y.C.) and AI089779 and DA028378 (to M.X.W.).

References

1. Kupper TS (2012) Old and new: recent innovations in vaccine biology and skin T cells. *J Invest Dermatol* 132(3 Pt 2):829–834
2. Nicolas JF, Guy B (2008) Intradermal, epidermal and transcutaneous vaccination: from immunology to clinical practice. *Expert Rev Vaccines* 7:1201–1214
3. Kim YC, Prausnitz MR (2011) Enabling skin vaccination using new delivery technologies. *Drug Deliv Transl Res* 1:7–12
4. Lang J, Hoa DQ, Gioi NV et al (1999) Immunogenicity and safety of low-dose intradermal rabies vaccination given during an Expanded Programme on immunization session in Viet Nam: results of a comparative randomized trial. *Trans R Soc Trop Med Hyg* 93:208–213
5. Beran J, Ambrozaitis A, Laiskonis A et al (2009) Intradermal influenza vaccination of healthy adults using a new microinjection system: a 3-year randomised controlled safety and immunogenicity trial. *BMC Med* 7:13
6. Leroux-Roels I, Vets E, Freese R et al (2008) Seasonal influenza vaccine delivered by intradermal microinjection: a randomised controlled safety and immunogenicity trial in adults. *Vaccine* 26:6614–6619
7. Leroux-Roels I, Weber F (2013) Intanza® 9 µg intradermal seasonal influenza vaccine for adults 18 to 59 years of age. *Hum Vaccin Immunother* 9:115–121
8. Madhusudana SN, Mani RS (2014) Intradermal vaccination for rabies prophylaxis: conceptualization, evolution, present status and future. *Expert Rev Vaccines* 13:641–655
9. Grubeck-Loebenstien B, Della BS, Iorio AM, Michel JP, Pawelec G, Solana R (2009) Immunosenescence and vaccine failure in the elderly. *Aging Clin Exp Res* 21:201–209

10. Boraschi D, Italiani P (2014) Immunosenescence and vaccine failure in the elderly: strategies for improving response. *Immunol Lett* 162(1 Pt B):346–353
11. Holland D, Booy R, De LF et al (2008) Intradermal influenza vaccine administered using a new microinjection system produces superior immunogenicity in elderly adults: a randomized controlled trial. *J Infect Dis* 198:650–658
12. Chen X, Wu MX (2011) Laser vaccine adjuvant for cutaneous immunization. *Expert Rev Vaccines* 10:1397–1403
13. Chen X, Wang J, Shah D, Wu MX (2013) An update on the use of laser technology in skin vaccination. *Expert Rev Vaccines* 12:1313–1323
14. Krejci J, Nechvatalova K, Kudlackova H et al (2013) Effects of adjuvants on the immune response of pigs after intradermal administration of antigen. *Res Vet Sci* 94:73–76
15. Ward JR, Jones RS (1962) Studies on adjuvant-induced polyarthritis in rats. I. Adjuvant composition, route of injection, and removal of depot site. *Arthritis Rheum* 5:557–564
16. Chen X, Kosiratna G, Zhou C, Manstein D, Wu MX (2014) Micro-fractional epidermal powder delivery for improved skin vaccination. *J Control Release* 192:310–316
17. Chen X, Kim P, Farinelli B et al (2010) A novel laser vaccine adjuvant increases the motility of antigen presenting cells. *PLoS One* 5(10): e13776

Part VIII

Vaccine Bioinformatics

Chapter 47

A Bioinformatics Method for the Design of Live Attenuated Virus Vaccine Utilizing Host MicroRNA Response Elements

Duangdao Wichadakul

1 Introduction

Several studies demonstrated that the host microRNA machinery has anti-viral property [1–5]. Hence, it has been taken as a promising genetic tool for developing attenuated viruses as live vaccines [6–9]. Perez et al. generated the reassortant live attenuated influenza vaccines (LAIVs) for H1N1 and H5N1 by incorporating the non-avian microRNA response elements (MREs) into the open-reading frame (ORF) of the influenza A nucleoprotein. The MRE-based LAIVs resulted in significantly less mortality compared with controlled viruses without MREs [7]. Likewise, Barnes et al. used the poliovirus as the model and showed that the viruses harbored with MREs of the neuronal-specific miRNA were significantly attenuated in the central nervous system but still retained the replication ability in non-neuronal tissues [6]. Lee et al. demonstrated another similar restriction replication effect, incorporating MREs of the hepatic-specific miRNA into the dengue virus (DEN) replicons [8]. These results mainly focused on a specific host miRNA and a few virus sequences. Furthermore, sites for MRE insertion can be varied from 3' UTR to the open reading frames (ORFs) with different complexities. To employ the MREs into the OPFs, for instances, the number of amino acid substitutions and the effects of changed physical properties such as hydrophobicity, polarity, and charges, due to the mutated bases in the nucleotide level need to be considered. Here, we describe a generic computational flow, which can be used to simultaneously design the effective MREs in large-scale. The flow accepts

the multiple or genome-wide miRNAs of interest together with the multiple sets of virus sequences. It then generates the effective MREs for each miRNAs taking the effects of mutated bases into account.

2 Materials

The sequence data necessary for identifying MREs can be divided into two sets. Here, we describe how to obtain and pre-process these data sets.

2.1 Host microRNA sequences

1. Download mature microRNA (miRNA) sequences file (`mature.fa`) from miRBase [10, 11] (<http://www.mirbase.org/>).
2. Prepare a list of miRNAs of interest for a specific host (i.e., hsa-miR-93), tissue, and virus (*see Note 1*).
3. Extract mature miRNA sequences of the specific host of interest from the `mature.fa` file using the `extract_fasta_sequences_separate_file.py` script (Fig. 1). This script takes two parameters: (1) the mature miRNA sequence file in FASTA format (i.e., `mature.fa`), and (2) a list of miRBase IDs of interest (prepared from **item 2**). It then generates a set of FASTA files; each contains a miRBase ID and its associated sequence.

2.2 Virus Sequences

1. Download the sequences of a virus to be used for constructing a live attenuated vaccine. The influenza coding sequences (`influenza.cds`) and the sequence information (`genomeset.dat`), for examples, can be downloaded from <ftp://ftp.ncbi.nih.gov/genomes/INFLUENZA/>. Other virus sequences can be downloaded from the viral genomes at NCBI (<http://www.ncbi.nlm.nih.gov/genome/viruses/>).
2. Extract the downloaded virus sequences into the same gene or gene segment sets using the `extract_fasta_sequences_rna_virus.py` script (Fig. 2). This script takes two parameters: (1) a virus coding sequence file (i.e., `influenza.cds`) in FASTA format, and (2) a list of genes or gene segments of interest such as gene segment 5 of H1N1 viruses (i.e., `seg_5_H1N1_2009_genelist`), extracted from the sequence information `genomeset.dat` file. The script then generates a FASTA file (i.e., `seg_5_H1N1_2009_genelist.out`), which contains sequences of genes listed in the input gene set.
3. Manually clean sequences within the same group and then align them together using a multiple sequence alignment software such as MUSCLE [12]. The conserved regions across the aligned sequences suggest areas that are more suitable for incorporating MREs.

```

1  import sys
2  from Bio import SeqIO
3
4  seq_file = sys.argv[1]
5  miRlist_file = sys.argv[2]
6
7  def seqDict(file1):
8      seqdict = dict()
9      fr = open(file1, "r")
10     for record in SeqIO.parse(fr, "fasta"):
11         if not seqdict.__contains__(record.id):
12             seqdict.__setitem__(record.id, str(record.seq))
13     fr.close()
14     return seqdict
15
16 def extractMirSeq(file1):
17     infile = open(file1, "r")
18     for miRName in infile:
19         miRName = str.strip(miRName)
20         if seq_dict.__contains__(miRName):
21             seq = seq_dict[miRName]
22             fw = open(miRName + ".out", "w")
23             fw.write(seq + "\n")
24             fw.close()
25         else:
26             miRName_5p = miRName + "-5p"
27             miRName_3p = miRName + "-3p"
28             n5p = 0
29             n3p = 0
30             if seq_dict.__contains__(miRName_5p):
31                 fw = open(miRName_5p + ".out", "w")
32                 seq = seq_dict[miRName_5p]
33                 fw.write(">" + miRName_5p + "\n")
34                 fw.write(seq + "\n")
35                 fw.close()
36                 n5p = 1
37             if seq_dict.__contains__(miRName_3p):
38                 fw = open(miRName_3p + ".out", "w")
39                 seq = seq_dict[miRName_3p]
40                 fw.write(">" + miRName_3p + "\n")
41                 fw.write(seq + "\n")
42                 fw.close()
43                 n3p = 1
44             if (n5p == 0) and (n3p == 0):
45                 print "gene : %s does not have sequence" %(miRName)
46     infile.close()
47 #=== main ===#
48 seq_dict = seqDict(seq_file)
49 extractMirSeq(miRlist_file)

```

Fig. 1 extract_fasta_sequences_separate_file.py, an example of Python source code used for extracting mature miRNA sequences of the specific host of interest from the mature .fa file into FASTA files, each containing an individual miRNA sequence

```

1 import sys
2 from Bio import SeqIO
3
4 seq_file = sys.argv[1]
5 genelist_file = sys.argv[2]
6
7 fw = open(genelist_file + ".out", "w")
8
9 def seqDict(file1):
10     seqdict = dict()
11     fr = open(file1, "r")
12     for record in SeqIO.parse(fr, "fasta"):
13         tokens = record.id.split("|")
14         name = tokens[1].split(":")[0]
15         if not seqdict.__contains__(name):
16             seqdict.__setitem__(name, str(record.seq))
17     fr.close()
18     return seqdict
19
20 def extractRNASeq(file1):
21     infile = open(file1, "r")
22     for line in infile:
23         line = str.strip(line)
24         tokens = line.split(",")
25         seq_name = tokens[0] + "_" + tokens[2] + "_" + tokens[4] + "_" + tokens[3] + "_" + tokens[1]
26         if seq_dict.__contains__(tokens[0]):
27             seq = seq_dict[tokens[0]]
28             fw.write(">" + seq_name + "\n")
29             fw.write(seq + "\n")
30         else:
31             print "gene : %s does not have sequence" %(line)
32     infile.close()
33     fw.close()
34
35 #== main ==
36 seq_dict = seqDict(seq_file)
37 extractRNASeq(genelist_file)

```

Fig. 2 `extract_fasta_sequences_rna_virus.py`, an example of Python source code for extracting sequences of a same gene set of interest from the downloaded virus sequences (`influenza.cds`)

3 Methods

Proceed with the following steps to design and prioritize the effective MREs.

1. Deploy a miRNA target prediction tool such as miRanda [13, 14] or multiple tools to predict the potential host's microRNA binding sites on the virus sequences (*see* **Notes 2** and **3**).

In case of miRanda, an individual miRNA and a set of virus sequences of the same gene are used as the input for each execution. The `scripting_miranda.py` (Fig. 3) is a helper script that takes a set of host's miRNAs and a set of virus sequences of the same gene set. It then generates a shell script file (i.e., `seq_5_H1N1_2009_genelist.out.miranda_run`) that contains command lines of miRanda call for each host's miRNA against the virus sequences. To execute the generated script file, we need to change its mode to be executable. The miRanda's result files are then extracted using the `extract_miranda_result.py` script (Fig. 4). The main outputs of this script are

```

1 import sys
2
3 miRNA_seq_files_list = sys.argv[1]
4 rna_seq_file = sys.argv[2]
5
6 def scriptingMiranda(file1, file2):
7     fw = open(file2 + ".miranda_run", "w")
8     infile = open(file1, "r")
9     for miRNA in infile:
10        miRNA = str.strip(miRNA)
11        outfile = miRNA + "_" + rna_seq_file
12        outfile = outfile.replace(".", "")
13        fw.write("miranda " + miRNA + " " + rna_seq_file + " -sc 120 > " + outfile + ".miranda" + "\n")
14    infile.close()
15    fw.close()
16
17 #== main ==
18 scriptingMiranda(miRNA_seq_files_list, rna_seq_file)

```

Fig. 3 `scripting_miranda.py`, an example of Python source code for generating a shell script file containing a set of command lines of miRanda call for each host's miRNA sequence (extracted from script shown in Fig. 1) against the virus sequences (extracted from script shown in Fig. 2)

(1) the summary of the miRNA's binding sites predicted by miRanda (i.e., `seg_5_H1N1_2009.miranda_extracted_summary`, see **Note 4**) and (2) a set of mutated virus sequence files and a shell script, under the mutation directory, for rerunning miRanda using the same set of host miRNAs against these mutated sequences (see **Note 5**). These mutated sequence files were also translated into protein sequence files using the `translate_to_protein.py` script (Fig. 5).

2. For each predicted site, for all mismatched positions, perform combinatorial mutations and calculate the binding energy score, identity (see **Note 6**), the number of amino acid substitutions, and the effects of changed physical properties (i.e., hydrophobicity, polarity, and/or charge) of amino acids due to the mutated bases in the nucleotide level. The `test_position.py` script (Fig. 6) was used for these calculations. Mainly, it compares the original protein sequence and protein sequences resulted from the mutated bases in the nucleotide level.
3. Generate the summary file using the `generate_MRE_summary.py` script (Fig. 7). All host's miRNAs of interest together with their top ranked MREs, the calculated scores and the effects of changed physical properties will be summarized into a text file (i.e., `seg_5_mutated_miranda_files.txt.extracted_summary`). Prioritize the MREs with the following conditions.
 - (a) Having a higher binding score with a lower binding energy against the host miRNA (see **Note 6**).
 - (b) Having less number of amino acid substitutions and effects on their physical properties.

```

1  import sys
2  import os
3  from Bio import SeqIO
4
5  miranda_files = sys.argv[1]
6  outDir = sys.argv[2]
7  seq_file = sys.argv[3]
8  segment = sys.argv[4]
9
10 def buildSeqDict(seq_file):
11     seqdict = dict()
12     fr = open(seq_file, "r")
13     for record in SeqIO.parse(fr, "fasta"):
14         if not seqdict.__contains__(record.id):
15             seqdict.__setitem__(record.id, str(record.seq))
16     return seqdict
17
18 def getMatchType(ca, cb):
19     if ca.upper() == "A" and cb.upper() == "T": return "skip"
20     if ca.upper() == "T" and cb.upper() == "A": return "skip"
21     if ca.upper() == "C" and cb.upper() == "G": return "skip"
22     if ca.upper() == "G" and cb.upper() == "C": return "skip"
23     if ca.upper() == "U" and cb.upper() == "A": return "skip"
24     if ca.upper() == "A" and cb.upper() == "U": return "skip"
25     if ca.upper() == "-": return "skip"
26
27 def combinations(iterable, r):
28     # source of this function: https://docs.python.org/2/library/itertools.html
29     # combinations("ABCD", 2) -> AB AC AD BC BD CD
30     # combinations(range(4), 3) -> 012 013 023 123
31     pool = tuple(iterable)
32     n = len(pool)
33     if r > n:
34         return
35     indices = range(r)
36     yield tuple(pool[i] for i in indices)
37     while True:
38         for i in reversed(range(r)):
39             if indices[i] != i + n - r: break
40         else: return
41         indices[i] += 1
42         for j in range(i+1, r):
43             indices[j] = indices[j-1] + 1
44         yield tuple(pool[i] for i in indices)

```

Fig. 4 extract_miranda_result.py, an example of Python source code for extracting the result files generated from miRanda

```

46 def extract_file(inmirandafile):
47     fr = open(inmirandafile, "r")
48     fw = open(outDirFull + inmirandafile + ".extracted", "w")
49     fw1 = open(outDirFull + inmirandafile + ".extracted_summary", "w")
50     seq_name = seq_status = key = miRNA_seq = target_seq = energy = ""
51     mutationDict = dict()
52     while 1:
53         line1 = fr.readline(); line = str.strip(line1)
54         if line == "Scan Complete":break
55         if line != "":
56             tokens = line.split()
57             if tokens[0][0] == ">" and tokens[0][1] != ">":
58                 line2 = str.lstrip(line1)
59                 fw1.write(seq_name + "\t" + line2)
60                 fw_miranda.write(seq_name + "\t" + line2)
61                 key = key + "_" + miRNA_seq + "_" + target_seq
62                 key_upper_str = key.upper()
63                 if not mutationDict.__contains__(key_upper_str):
64                     seq_names = list()
65                     seq_names.append(seq_name)
66                     mutationDict.__setitem__(key_upper_str, seq_names)
67                 else:
68                     seq_names = mutationDict[key_upper_str]
69                     seq_names.append(seq_name)
70                     mutationDict[key_upper_str] = seq_names
71             if tokens[0] == "Read":
72                 subtokens = tokens[1].split(":")
73                 seq_name = subtokens[1]
74             if tokens[0] == "Forward:":
75                 seq_status = seq_status + line1
76                 key = tokens[6].replace("R:", "") + "_" + tokens[8]
77             if tokens[0] == "Query:":
78                 seq_status = seq_status + line1
79                 line1 = fr.readline(); line = str.strip(line1)
80                 seq_status = seq_status + line1
81                 miRNA_seq = tokens[2]
82             if tokens[0] == "Ref:":
83                 seq_status = seq_status + line1
84                 target_seq = tokens[2]
85             if tokens[0] == "Energy:":
86                 seq_status = seq_status + line1
87             if tokens[0] == "Complete":
88                 if seq_status != "":
89                     fw.write("\n" + seq_name + "\n")
90                     fw.write(seq_status)
91                     seq_name = seq_status = ""
92     fr.close(); fw.close(); fw1.close()
93     return mutationDict

```

Fig. 4 (continued)

```

95 def generateToMutatePoints(key):
96     pattern = r"[^_]+"
97     tokens = key.split("_")
98     to_mutate_points = dict()
99     start = int(tokens[0])
100    stop = int(tokens[1])
101    count = 0
102    for ca in tokens[2]:
103        if getMatchType(ca, tokens[3][count]) != "skip":
104            if start + count <= stop:
105                if ca.upper() == "U":
106                    to_mutate_points.__setitem__(start+count, "A")
107                elif ca.upper() == "G":
108                    to_mutate_points.__setitem__(start+count, "C")
109                elif ca.upper() == "T":
110                    to_mutate_points.__setitem__(start+count, "A")
111                elif ca.upper() == "A":
112                    to_mutate_points.__setitem__(start+count, "T")
113                elif ca.upper() == "C":
114                    to_mutate_points.__setitem__(start+count, "G")
115            count = count + 1
116    point_keys = to_mutate_points.keys()
117    all_combinations = list()
118    count = len(point_keys)
119    while count > 0:
120        cc = combinations(point_keys, count)
121        l = list(cc)
122        all_combinations = all_combinations.__add__(l)
123        count = count - 1
124    return to_mutate_points, all_combinations

```

Fig. 4 (continued)

- (c) Located on a region conserved across the aligned sequences of the same gene set (*see Note 7*). This is based on the assumption that the conserved regions will be more important and have lower mutation rate in nature compared with other regions. Hence, MREs in these regions should be safe from the escape mutation of the virus.

The deployment of multiple MREs of multiple miRNAs simultaneously may help alleviate the escape mutations across the generations.

4 Notes

1. MREs of which host miRNAs will be incorporated into the virus sequences depends on the ubiquity of those host miRNAs

```

126 def generateMutationFiles(mut_dict, filename):
127     subDirName = filename.replace("_genelist.miranda", "")
128     keys = mut_dict.keys()
129     if len(keys) > 0:
130         if not os.path.exists(mutationOutDirFull + subDirName + "/"):
131             os.makedirs(mutationOutDirFull + subDirName + "/")
132             fw_miRNAs = open(mutationOutDirFull + "run_miranda" + "_" + segment, "a+")
133             index = subDirName.find("-")
134             hsa_name = subDirName[0:index]
135             for k in keys:
136                 l = mut_dict[k]
137                 if len(l) > mutCutoff:
138                     to_mutate_points, all_combinations = generateToMutatePoints(k)
139                     fw_mutate_file = open(mutationOutDirFull + subDirName + "/" + k[0:14] + ".out", "w")
140                     fw_miRNAs.write("miranda " + "../.." + hsa_name + ".out" + " " + subDirName + \
141                                     "/" + k[0:14] + ".out" + " -sc 120" + " > " + subDirName + "/" + k[0:14] + ".miranda" + "\n")
142                     seq_name = l[0]
143                     seq = seqDict[seq_name]
144                     fw_mutate_file.write(">" + seq_name + "\n")
145                     fw_mutate_file.write(seq + "\n")
146                     for a in all_combinations:
147                         ss = ""
148                         seq_mutate = seqDict[seq_name]
149                         seq_mutate_list = list(seq_mutate)
150                         a_length = len(a)
151                         a = sorted(a)
152                         a_length_count = 0
153                         while a_length_count < a_length:
154                             ss = ss + " " + str(a[a_length_count])
155                             seq_mutate_list[a[a_length_count]-1] = to_mutate_points[a[a_length_count]]
156                             a_length_count = a_length_count + 1
157                             fw_mutate_file.write(">" + seq_name + ss + "\n")
158                             seq_mutate = "".join(seq_mutate_list)
159                             fw_mutate_file.write(seq_mutate + "\n")
160                     fw_mutate_file.close()
161             if len(keys) > 0:
162                 fw_miRNAs.close()
163
164 def findDiffPositions(seq_name_1, seq_name_2, seq1, seq2):
165     line_fr1_list = list(seq1)
166     line_fr2_list = list(seq2)
167     count = 0
168     for a in line_fr1_list:
169         if a != line_fr2_list[count]:
170             print "different position = %d, from %c to %c" %(count+1, a, line_fr2_list[count])
171     count = count + 1

173 #=== main ===
174 mutCutoff = 5
175 rootDir = ""
176 outDirFull = outDir + "/"
177 mutationOutDirFull = outDirFull + "mutation/"
178
179 seqDict = buildSeqDict(seq_file)
180 if not os.path.exists(outDirFull):
181     os.makedirs(outDirFull)
182 if not os.path.exists(mutationOutDirFull):
183     os.makedirs(mutationOutDirFull)
184
185 fw_miranda = open(rootDir + outDir + ".miranda_extracted_summary", "w")
186 fr_main = open(miranda_files, "r")
187 for filename in fr_main:
188     filename = str.strip(filename)
189     mutDict = extract_file(filename)
190     generateMutationFiles(mutDict, filename)
191 fr_main.close()
192 fw_miranda.close()

```

Fig. 5 translate_to_protein.py, an example of Python source code for translating the mutated nucleotide sequences generated from script shown in Fig. 4 into protein sequences

```

1  import sys
2  from Bio import SeqIO
3  from Bio.Seq import Seq
4
5  fasta_files = sys.argv[1]
6
7  def translateToProtein(file1):
8      infile = open(file1, 'r')
9      for filename in infile:
10         filename = str.strip(filename)
11         fr1 = open(filename, 'r')
12         fw1 = open(filename + '.prot', 'w')
13         for record in SeqIO.parse(fr1, "fasta"):
14             seq = Seq(str(record.seq))
15             coding_prot = seq.translate()
16             fw1.write('> ' + record.id + '\n')
17             fw1.write(str(coding_prot) + '\n')
18         fr1.close()
19         fw1.close()
20     infile.close()
21 #=== main ===
22 translateToProtein(fasta_files)

```

Fig. 6 test_position.py, an example of Python source code for comparing the original protein sequence and the protein sequences translated from the mutated nucleotide sequences. It calculates the number of amino acid substitutions, the changed physical properties and their effects

in the specific tissues and the pathogenesis of the virus. Based on previously published results in [15–18], Perez et al. decided to incorporate MREs of miR-93 into the influenza A virus as miR-93 is ubiquitously expressed in both murine and human lung tissue but not expressed in chicken (for egg-grown virus) [7]. Barnes et al. chose to harbor MREs of let-7a and miR-124a into the poliovirus where miR-124a and let-7a is neuronal-specific and ubiquitous, respectively [6]. Lee et al. decided to incorporate the MREs of miR-122 into the dengue virus (DEN), as it is hepatic-specific [8].

2. The use of multiple target prediction tools that are reliable will help improve the coverage and correctness of MRE identifica-

```

1 import sys
2 from Bio import SeqIO
3 fasta_files = sys.argv[1]
4
5 def testPosition(file1):
6     prop_dict = {"G":"non_polar", "A":"non_polar", "P":"non_polar", "C":"non_polar", "M":"non_polar",
7                 "F":"non_polar", "V":"non_polar", "I":"non_polar", "L":"non_polar", "Q":"polar",
8                 "N":"polar", "T":"polar", "S":"polar", "Y":"polar", "W":"polar", "R":"charged",
9                 "H":"charged", "D":"charged", "K":"charged", "E":"charged"}
10    infile = open(file1, 'r')
11    for fasta_file in infile:
12        fasta_file = str.strip(fasta_file)
13        fr = open(fasta_file, 'r')
14        fw = open(fasta_file + '_mutated_count', 'w')
15        original_seq_name = original_seq = mutated_seq_name = mutated_seq = ""
16        original_seq_list = mutated_seq_list = []
17        first_seq = 1
18        for record in SeqIO.parse(fr, "fasta"):
19            if first_seq == 1:
20                original_seq_name = record.id; original_seq = str(record.seq)
21                original_seq_list = list(original_seq)
22                first_seq = 0
23            else:
24                mutated_seq_name = record.id; mutated_seq = str(record.seq)
25                mutated_seq_list = list(mutated_seq)
26                count = physical_prop_affected = 0
27                mutated_count = []
28                for a in original_seq_list:
29                    if a != mutated_seq_list[count]:
30                        note = str(count+1) + '_' + a + '_' + mutated_seq_list[count]
31                        mutated_count.append(note)
32                        if a != '*':
33                            if mutated_seq_list[count] != '*':
34                                if prop_dict[a] != prop_dict[mutated_seq_list[count]]:
35                                    physical_prop_affected = physical_prop_affected + 1
36                                else:
37                                    physical_prop_affected = physical_prop_affected + 1000
38                            else:
39                                physical_prop_affected = physical_prop_affected + 1000
40                        count = count + 1
41                fw.write(original_seq_name + '\t' + mutated_seq_name + '\t' + str(len(mutated_count)) + \
42                        '\t' + str(physical_prop_affected) + '\t')
43                for n in mutated_count:
44                    fw.write '[' + n + ']' + ','
45                fw.write('\n')
46        fr.close(); fw.close()
47    infile.close()
48    #== main ==
49    testPosition(fasta_files)

```

Fig. 6 (continued)

tion in the first step. Xiao et al. gave a comprehensive review and assessment of available miRNA target prediction tools [19].

3. The available miRNA target prediction tools were designed and developed based on varied algorithms and training sets. Hence, to deploy a combination of tools, try to select tools that are complementary.
4. The predicted binding sites resulted from the first step of the computational flow (i.e., `seq_5_H1N1_2009.miranda_extracted_summary`) may be used by virologists. However, this does not guarantee their binding effectiveness.
5. We may just mutate the mismatches of a binding site to be perfectly complemented. However, we need to carefully consider the effects of mutated nucleotides on the protein level.

```

30 def extract_file(inmirandafile):
31     fr = open(inmirandafile, "r")
32     seq_name = seq_status = ""
33     energy = 0.0
34     tokens_dir = inmirandafile.split("/")
35     mir = tokens_dir[2].split("_")[0]
36     segment = tokens_dir[2].split("_")[1] + "_" + tokens_dir[2].split("_")[2]
37     tokens_file = tokens_dir[3]
38     tokens_file_exact = tokens_file.split(".")
39     start = tokens_file_exact[0]; stop = tokens_file_exact[1]
40     tokens_file_wo_ext = tokens_file.split(".")
41     file_prot_mutated_count = tokens_dir[2] + "/" + tokens_file_wo_ext[0] + ".out.prot_mutated_count"
42     prot_mutated_dict = build_mutated_dict(tokens_dir[0] + "/" + tokens_dir[1] + "/" + file_prot_mutated_count)
43     while 1:
44         line1 = fr.readline(); line = str.strip(line1)
45         if line == "Scan Complete":break
46         if line != "":
47             tokens = line.split()
48             if tokens[0][0] == ">" and tokens[0][1] != ">":
49                 line2 = str.lstrip(line1)
50                 if energy <= energy_cutoff:
51                     tokens_temp = line2.split()
52                     fw1.write(mir + "\t" + segment + "\t" + start + "_" + stop + "\t" + seq_name + "\t" + tokens_temp[2] + "\t" + \
53                             tokens_temp[3] + "\t" + tokens_temp[4] + "_" + tokens_temp[5] + "\t" + tokens_temp[8] + "\t" + tokens_temp[9] + \
54                             "\t" + tokens_temp[10] + "\t" + str(prot_mutated_dict[seq_name].num_diff_aa) + "\t" + \
55                             str(prot_mutated_dict[seq_name].num_affected_prop_aa) + "\t" + prot_mutated_dict[seq_name].changed_aa + "\n")
56             if tokens[0] == "Read":
57                 subtokens = tokens[1].split(":"); seq_name = subtokens[1]
58             if tokens[0] == "Forward":
59                 seq_status = seq_status + line1
60             if tokens[0] == "Query":
61                 seq_status = seq_status + line1; line1 = fr.readline()
62                 line = str.strip(line1); seq_status = seq_status + line1
63             if tokens[0] == "Ref":
64                 seq_status = seq_status + line1
65             if tokens[0] == "Energy":
66                 seq_status = seq_status + line1
67                 energy = float(tokens[1])
68             if tokens[0] == "Complete":
69                 if seq_status != "":
70                     if energy <= energy_cutoff:
71                         fw.write(mir + " : " + segment + " : " + seq_name + "\n")
72                         fw.write(seq_status)
73                 seq_name = seq_status = ""; energy = 0.0
74     fr.close()
75 #== main ==
76 fr_main = open(miranda_files, "r")
77 for miranda_file in fr_main:
78     miranda_file = str.strip(miranda_file)
79     extract_file(miranda_file)
80 fr_main.close()

```

Fig. 7 (continued)

References

1. Lecellier CH, Dunoyer P, Arar K et al (2005) A cellular microRNA mediates antiviral defense in human cells. *Science* 308:557–560
2. Nathans R, Chu C-y, Serquina AK et al (2009) Cellular microRNA and P bodies modulate host-HIV-1 interactions. *Mol Cell* 34:696–709
3. Zheng S-q, Li Y-x, Zhang Y et al (2011) MiR-101 regulates HSV-1 replication by targeting ATP5B. *Antiviral Res* 89:219–226
4. Song L, Liu H, Gao S et al (2010) Cellular microRNAs inhibit replication of the H1N1 influenza A virus in infected cells. *J Virol* 84:8849–8860
5. Otsuka M, Jing Q, Georgel P et al (2007) Hypersusceptibility to vesicular stomatitis virus infection in Dicer1-deficient mice is due to impaired miR24 and miR93 expression. *Immunity* 27:123–134
6. Barnes D, Kunitomi M, Vignuzzi M et al (2008) Harnessing endogenous miRNAs to control virus tissue tropism as a strategy for developing attenuated virus vaccines. *Cell Host Microbe* 4:239–248
7. Perez JT, Pham AM, Lorini MH et al (2009) MicroRNA-mediated species-specific attenuation of influenza A virus. *Nat Biotechnol* 27:572–576
8. Lee T-C, Lin Y-L, Liao J-T et al (2010) Utilizing liver-specific microRNA-122 to modulate replication of dengue virus replicon. *Biochem Biophys Res Commun* 396: 596–601

9. Kelly EJ, Hadac EM, Greiner S et al (2008) Engineering microRNA responsiveness to decrease virus pathogenicity. *Nat Med* 14: 1278–1283
10. Griffiths-Jones S, Grocock RJ, van Dongen S et al (2006) miRBase: microRNA sequences, targets and gene nomenclature. *Nucleic Acids Res* 34:D140–D144
11. Griffiths-Jones S, Saini HK, van Dongen S et al (2008) miRBase: tools for microRNA genomics. *Nucleic Acids Res* 36:D154–D158
12. Edgar RC (2004) MUSCLE: multiple sequence alignment with high accuracy and high throughput. *Nucleic Acids Res* 32: 1792–1797
13. Enright A, John B, Gaul U et al (2003) MicroRNA targets in *Drosophila*. *Genome Biol* 5:R1
14. John B, Enright AJ, Aravin A et al (2004) Human microRNA targets. *PLoS Biol* 2, e363
15. Landgraf P, Rusu M, Sheridan R et al (2007) A mammalian microRNA expression atlas based on small RNA library sequencing. *Cell* 129: 1401–1414
16. Burnside J, Ouyang M, Anderson A et al (2008) Deep sequencing of chicken microRNAs. *BMC Genomics* 9:185
17. Barad O, Meiri E, Avniel A et al (2004) MicroRNA expression detected by oligonucleotide microarrays: system establishment and expression profiling in human tissues. *Genome Res* 14:2486–2494
18. Williams A, Perry M, Moschos S et al (2007) MicroRNA expression in the aging mouse lung. *BMC Genomics* 8:172
19. Fan X, Kurgan L (2015) Comprehensive overview and assessment of computational prediction of microRNA targets in animals. *Brief Bioinform* 16(5):780–794
20. Wichadakul D, Mhuantong W, Jongkaewwattana A et al (2012) A computational tool for the design of live attenuated virus vaccine based on microRNA-mediated gene silencing. *BMC Genomics* 13(Suppl 7):S15

The Web-Based DNA Vaccine Database DNAVaxDB and Its Usage for Rational DNA Vaccine Design

Rebecca Racz and Yongqun He

1 Introduction

A DNA vaccine, first introduced in the 1990s [1], consists of a DNA plasmid manufactured to encode one or more peptide antigens, is administered *in vivo*, and has the ability to induce a preventive or protective immune response against a disease or infection. Once *in vivo*, the encoded protein is expressed and degraded into peptides by antigen presenting cells. These peptides, or epitopes, can either trigger T cells through the antigen presenting cells or induce antibody responses through B cell antigen recognition [2]. DNA vaccines are easy to prepare and store, safe, and cost effective when compared to other types of vaccines, such as live attenuated or killed whole organism vaccines, and subunit vaccines. Additionally, DNA vaccines allow for a focused immune response on a particular antigen and can also induce long-lasting and varied immune responses *in vivo*.

Exhaustive efforts have been taken to research and utilize DNA vaccines. Over 55,000 articles about DNA vaccines and their research have been cataloged in PubMed and/or Google Scholar. Currently four DNA vaccines have been licensed for veterinary uses [3]. There is no currently licensed human DNA vaccine, but several are presently in clinical trials. Research is also underway to better understand the mechanisms underlying DNA vaccination and resulting immunity.

As a relatively independent program under the comprehensive VIOLIN vaccine resource (<http://www.violinet.org>), DNAVaxDB [3] is the first publically available, Web-based database and analysis system for DNA vaccines, DNA vaccine-associated plasmids, and DNA vaccine-associated protective antigens [4]. As with the other recorded vaccines in the VIOLIN database,

each DNA vaccine in DNAVaxDB is experimentally verified to induce statistically significant protection against a disease in at least one laboratory animal model (ideally in the natural host). These vaccines have been used in a large array of both infectious and non-infectious diseases and conditions. Analysis of this data has shown many patterns in DNA vaccines, plasmids, and antigens. The use of these patterns together with computational analysis can further be used in DNA vaccine design and to better understand the protection mechanism behind DNA vaccines.

DNAVaxDB supports research in immunology, vaccinology, and microbiology and is expected to continue to grow and have a significant impact on vaccine development, research and design.

2 DNAVaxDB Development

2.1 Manual Curation of DNA Vaccine Data from Peer-Reviewed Articles

Each DNA vaccine stored in DNAVaxDB is typically associated with the following major items:

1. DNA vaccine name.
2. Host animal used as model.
3. Immunization route.
4. Stage of vaccine development (e.g., research, clinical trial, or licensed).
5. Vaccine efficacy in a pathogen challenge experiment.
6. Host immune responses.
7. DNA vaccine plasmid name.
8. Plasmid Vaccine Ontology (VO) identifier [5, 6] (*see Note 1*).
9. Plasmid reference.
10. If available, plasmid manufacturer, promoter, antibiotics resistance gene, and length.
11. Vaccine citation information. These references are usually found in PubMed (<http://www.ncbi.nlm.nih.gov/pubmed>), and the information in VIOLIN is retrieved from PubMed using the PubMed ID (i.e., PMID) and an internal script. Each vaccine and plasmid is assigned a VO identifier, linking the two databases.

2.2 The Status of DNAVaxDB Development

As of January 22, 2015, DNAVaxDB contains 421 DNA vaccines (Table 1). All vaccines in DNAVaxDB have been experimentally verified through either a challenge experiment or a protective level of antibodies to be protective or therapeutic in one or more laboratory animal models. DNAVaxDB contains 181 plasmids, 144 of which have been used in the 421 DNA vaccines. A total of 378

Table 1
DNAVaxDB statistics

Plasmid DNAs	Plasmids used in ≥ 1 vaccine	DNA vaccines	Infectious disease DNA vaccines	No. of infectious pathogens	Cancer DNA vaccines	Diabetes DNA vaccines	Arthritis DNA vaccines
181	144	421	378	101	35	4	4

DNA vaccines have been developed against 101 infectious diseases. DNA vaccines have also been developed for cancer (35 vaccines), diabetes (4 vaccines), and arthritis (4 vaccines).

3 Insights Obtained from DNAVaxDB Data Analysis

3.1 Analysis of DNAVaxDB Vaccine DNA Plasmids

The most commonly used plasmids can be found in Table 2. Popular plasmids included pcDNA3.1, pcDNA3, pVAX1, pVR1012, and pCI. Some patterns found in these plasmids include common promoters (i.e., human cytomegalovirus/immediate-early, or CMV promoter), terminators (i.e., SV40 polyadenylation terminator), and antibiotic resistance markers (i.e., ampicillin markers) [3].

4 DNAVaxDB Data Query, Display, and Data Sharing

DNAVaxDB can be queried by plasmid, antigen, or vaccine through three user-friendly Web interfaces (Figs. 1 and 2). These interfaces are interlinked, and each query is processed using PHP/against a backend relational database (MySQL version 5.5.28) and the results are displayed to the users in the Web browser. DNAVaxDB vaccine, antigen, and plasmid data can also be submitted through the VIOLIN online data curation system [4, 7].

A BLAST search program was specifically designed for DNAVaxDB [3]. This performs a sequence similarity search against our customized BLAST library, which holds over 380 protective antigens that have been used in DNA vaccine development.

5 Sandbox Case Study of Applying DNAVaxDB Data for Vaccine Design

Imagine you are approached to create a new DNA vaccine for *Mycobacterium bovis* [8]. You are asked to create a pure DNA vaccine, without priming or vaccinating in combination with any other vaccine. Where would you start?

Table 2
Plasmids in DNAVaxDB with two or more associated vaccines

Plasmid	VO ID	DNAVaxDB ID	No. of vaccines
pcDNA3.1	VO_0000158	17	51 (4; 15; 18; 7; 0; 7) ^a
pcDNA3	VO_0000132	16	41 (2; 4; 16; 11; 0; 8)
pVAX1	VO_0000024	74	24 (2; 1; 8; 10; 0; 3)
pVR1012	VO_0000334	78	19 (4; 0; 7; 5; 1; 2)
pCI	VO_0000212	21	17 (5; 2; 9; 0; 0; 1)
pJW4303	VO_0000276	46	11 (6; 3; 1; 0; 0; 1)
pWRG7077	VO_0000346	81	10 (0; 0; 9; 0; 0; 1)
pCMVi-UB	VO_0005027	114	10 (0; 10; 0; 0; 0; 0)
pCAGGS	VO_0000099	11	10 (0; 0; 10; 0; 0; 0)
pCI-neo	VO_0000214	22	9 (1; 4; 4; 0; 0; 0)
pIRES	VO_0000262	42	9 (0; 0; 9; 0; 0; 0)
pCAGGSP7	VO_0005000	85	8 (0; 0; 8; 0; 0; 0)
pVAX	VO_0000019	1	8 (0; 0; 6; 0; 0; 2)
pCMV	VO_0000215	23	7 (0; 0; 7; 0; 0; 0)
pcDNA 1/Amp	VO_0000130	15	5 (0; 0; 2; 3; 0; 0)
pCR3.1	VO_0000234	33	4 (1; 2; 0; 0; 0; 1)
pTARGET	VO_0000318	66	4 (0; 2; 1; 0; 0; 1)
pVIJ	VO_0000328	73	4 (0; 0; 4; 0; 0; 0)
pCI30	VO_0005028	115	4 (0; 4; 0; 0; 0; 0)
pcDNA1	VO_0005031	118	4 (0; 1; 3; 0; 0; 0)
pMV10.1	VO_0005036	123	4 (0; 0; 4; 0; 0; 0)
VIJns	VO_0005044	132	4 (0; 0; 4; 0; 0; 0)
pVR1020	VO_0005060	147	4 (0; 1; 3; 0; 0; 0)
pSW3891	VO_0005071	158	4 (0; 0; 4; 0; 0; 0)
pRSV	VO_0000305	60	3 (0; 0; 3; 0; 0; 0)
pCMV/R	VO_0005004	89	3 (0; 0; 3; 0; 0; 0)
pNGVL4a	VO_0005014	99	3 (0; 0; 2; 0; 0; 1)
pWRG7079	VO_0005059	146	3 (1; 1; 1; 0; 0; 0)
pcDNA3.1/V5-His-TOPO	VO_0005062	149	3 (0; 2; 1; 0; 0; 0)
pIRES1neo	VO_0005063	150	3 (0; 0; 3; 0; 0; 0)

(continued)

Table 2
(continued)

Plasmid	VO ID	DNAVaxDB ID	No. of vaccines
pCN3	VO_0000992	166	3 (0; 3; 0; 0; 0; 0)
pGACAG	VO_0000998	171	3 (0; 3; 0; 0; 0; 0)
pBK-SFV	VO_0000080	9	2 (0; 0; 2; 0; 0; 0)
pCMV-LIC	VO_0000230	30	2 (0; 0; 0; 2; 0; 0)
pMASIA	VO_0000284	51	2 (0; 0; 2; 0; 0; 0)
pND2	VO_0000293	53	2 (0; 0; 0; 0; 0; 2)
pRc/CMV	VO_0000301	57	2 (0; 0; 2; 0; 0; 0)
pWRG	VO_0005002	87	2 (0; 0; 2; 0; 0; 0)
pSin-B-gal	VO_0005011	96	2 (0; 0; 0; 0; 0; 2)
pCtPA	VO_0005035	122	2 (0; 0; 2; 0; 0; 0)
pCMVi (-H3) UBs	VO_0005041	128	2 (0; 0; 2; 0; 0; 0)
pCDNA	VO_0005048	135	2 (0; 0; 0; 2; 0; 0)
p1012	VO_0005050	137	2 (0; 0; 2; 0; 0; 0)
pCDL-Sra296	VO_0005054	141	2 (0; 0; 2; 0; 0; 0)
pUBIQ	VO_0005056	143	2 (0; 0; 2; 0; 0; 0)
pJW4304	VO_0005072	159	2 (0; 0; 1; 1; 0; 0)
VR1	VO_0000993	167	2 (0; 0; 2; 0; 0; 0)

^aTotal vaccines (Gram +; Gram -; Viral; Parasitic; Fungal; Other)

First, it is important to understand why *M. bovis* is important and how it is related to other pathogens. *M. bovis* is an aerobic bacterium that can cause tuberculosis, primarily in cattle, but it can also spread to humans [8]. It is part of the *Mycobacterium tuberculosis* complex, which also includes *Mycobacterium tuberculosis* [9]. Currently, there are two *M. bovis* vaccines in VIOLIN, including the live attenuated *M. bovis* *Bacillus Calmette-Guérin Danish* strain (BCG) [10] and a DNA vaccine, pCI-Ag85B [11]. It is impossible to use the information from these two vaccines to develop a new *M. bovis* DNA vaccine. However, the other information in DNAVaxDB and VIOLIN, including the *M. tuberculosis* vaccines and vaccines for other pathogens, could be used for rational design of a new *M. bovis* DNA vaccine. Such a rational design depends on the prediction of potential plasmids and antigens for *M. bovis*.

5.1 Plasmid Selection

One of the first steps in developing a DNA vaccine is selecting a plasmid. To develop a *M. bovis* DNA vaccine, we would look at the



Fig. 1 Searching a DNA vaccine by pathogen in DNAVaxDB. (a) “*Mycobacterium tuberculosis*” is queried in the DNAVaxDB vaccine search using the dropdown pathogen search box. (b) The search results from (a), *M. tuberculosis* DNA vaccines found in DNAVaxDB. Information about the vaccines or pathogen can be obtained by clicking on the respective links. Vaccines can be compared by checking boxes on the right and clicking “Compare”. (c) The circled vaccines in (b) are compared here. Information such as type, antigen, and vector in two or more vaccines can be seen side-by-side. Detailed antigen information can be accessed through the circled “Click Here” button. (d) Detailed antigen information for *M. tuberculosis* Ag85A. Information includes NCBI Gene, Protein, and/or Nucleotide IDs, species and strain of pathogen, and DNA and protein sequence of the antigen

plasmids used in *M. tuberculosis* and the patterns found in the plasmid selection of that pathogen. Commonly used plasmids in this pathogen include pJW4303 [12] and pcDNA3.1 [13]. Therefore, we might choose to start with these plasmids when designing our novel *M. bovis* DNA vaccine.

If there was not a pattern present in *M. tuberculosis* or if research had not been done on a related species, a plasmid could also be chosen through our analysis of commonly used plasmids (Table 2). Here, we showed that some plasmids are used more often in the following: gram-positive species, gram-negative species, viruses, etc. Because *M. bovis* is a gram-positive bacterium, we could choose a plasmid that is used more commonly in gram-positive bacteria, such as pJW4303.

(a) Search Results:

Search: Keywords: in Any Field
 and in DNA Vaccine Plasmid Name
 and in DNA Vaccine Plasmid Name
 Select: **Mycobacterium tuberculosis (Tuberculosis)** Search

(b) Found 7 DNA vaccine plasmids:

Index	DNA vaccine plasmid name	No. of vaccines using this plasmid	No. of vaccines for Mycobacterium tuberculosis (Tuberculosis) using this plasmid
1	pBucCE4.1 DNA vaccine plasmid	2	1
2	pJW4303 DNA vaccine plasmid	56	2
3	pJW4303 DNA vaccine plasmid	12	4
4	JE1116 tuberculosis plasmid	1	1
5	pJW4303 DNA vaccine plasmid	1	1
6	pRC DNA vaccine plasmid	1	1
7	pAK-4 DNA vaccine plasmid	1	1

(c) pJW4303 DNA vaccine plasmid:

DNA Vaccine Plasmid ID: 46
 DNA Vaccine Plasmid Name: pJW4303 DNA vaccine plasmid
 Plasmid VO ID: VO_0000276

Related Vaccine(s):

- Influenza virus DNA vaccine HA-DNA (Influenza virus)
- M. tuberculosis DNA vaccine encoding ESAT-6 (Mycobacterium tuberculosis)
- M. tuberculosis DNA vaccine ESAT-6 (Mycobacterium tuberculosis)
- M. tuberculosis DNA vaccine encoding ESAT-6, MPT64, MPT-63, and KatG constructs (Mycobacterium tuberculosis)
- B. abortus DNA vaccine expressing BCSP31, SOO and L7/L12 (Brucella spp.)
- DNA vaccine encoding PA (PA63) (Bacillus anthracis)
- M. tuberculosis DNA vaccine encoding KatG (Mycobacterium tuberculosis)
- V. cholerae CTB DNA Vaccine (Vibrio cholerae)
- M. aium DNA vaccine DNA-A-059p24L12 (Mycobacterium aium)
- Insulin-dependent diabetes mellitus DNA vaccine: JwG4D65 + IL-4 (Diabetes)
- Y. pestis DNA vaccine YscF-2 (Yersinia pestis)

(d) M. tuberculosis DNA vaccine ESAT-6:

Vaccine Information:

- Vaccine Name: Tuberculosis DNA vaccine ESAT-6
- Target Pathogen: Mycobacterium tuberculosis
- Target Disease: Tuberculosis
- Type: DNA vaccine
- Status: Research
- Host Species as Laboratory Animal Model: Mouse
- DNA vaccine plasmid: pJW4303 DNA vaccine plasmid
- DNA vaccine plasmid name: pJW4303 DNA vaccine plasmid
- DNA vaccine plasmid VO ID: VO_0000276
- Immunization Route: Intramuscular injection (i.m.)

Host Response:

- Immune Response: Immune Response Type: VO_0000286
- Immune Response: Immune response with a multivalent combination DNA vaccine (containing the ESAT-6, MPT-64, MPT-63, and KatG constructs) generated immune responses that indicated an absence of antigenic competition since antigen-specific cell-mediated and humoral responses were detected to each component of the mixture (Shen et al., 2005).
- Efficacy: Prior to vaccination, mice were challenged with M. tuberculosis. Among the single DNA vaccines that were tested, the ESAT-6 construct consistently showed the best protective responses. Compared with BCG, which on an avian scale elicited a protective value of 1, ESAT-6 elicited a protective value of 81 (Shen et al., 2005).
- Information about this animal model: Mouse Model for TB research

References:

Shen et al., 2005; Shen S, Kahley C, Howard A, Li Z, Collins F. The immunogenicity of single and combination DNA vaccines against tuberculosis. Vaccine 2005; 23(26): 2700-2703. [PubMed: 15716376]

Fig. 2 Searching a DNA vaccine plasmid in DNAVaxDB. (a) “*Mycobacterium tuberculosis*” is queried in the DNAVaxDB plasmid search using the dropdown pathogen search box. (b) The search results from (a), plasmids utilized in *M. tuberculosis* DNA vaccines found in DNAVaxDB. Information about the plasmid, *M. tuberculosis* vaccines using each plasmid, or all vaccines using each plasmid can be obtained by clicking on the respective links. (c) Plasmid information page. Information such as plasmid name, VO ID, references, and vaccines utilizing the plasmid are displayed here. (d) How plasmid pJW4303 appears in Vaccine Ontology, or VO, obtained by clicking on the VO ID in (c). (e) Vaccine information for one of the vaccine utilizing pJW4304, obtained by clicking on the vaccine link in (c)

5.2 Protective Antigen Prediction or Screening

The next step in designing a new DNA vaccine for *M. bovis* is to pick a protective antigen. There are multiple ways to go about this.

One method is to analyze the vaccines and protective antigens used in the *M. tuberculosis* DNA vaccines. Commonly used protective antigens in *M. tuberculosis* DNA vaccines are Ag85A (mycolyltransferase, involved in cell envelope biogenesis) [14], KatG (catalase-peroxidase, which detoxifies compounds generated by host macrophages) [15], and MPT64 (secreted immunogenic antigen) [16]. A strategy for creating an *M. bovis* DNA vaccine would be to use orthologs of these protective antigens or other antigens with similar functions in *M. bovis*.

Another method to gather potential protective antigens for use in a novel *M. bovis* DNA vaccine is to use another VIOLIN program,

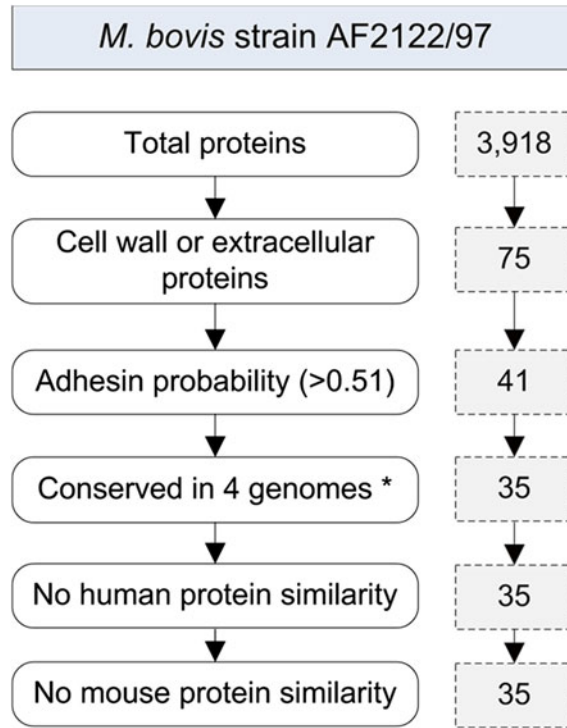

**M. tuberculosis* strains CDC1551, F11, H37Rv, and KZN 1435

Fig. 3 Vaxign criteria to obtain potential protective antigens in *M. bovis* strain AF2122/97. Flowchart of the addition of criteria in Vaxign and the resulting number of potential vaccine targets after each addition

Vaxign [17]. This program was created specifically to predict useful genes for vaccine design. As of January 21, 2015, 15 *Mycobacterium* genomes were pre-computed and the data stored in Vaxign for queries. One of the 15 genomes is *M. bovis* strain AF2122/97 [18]. The genome of this strain includes 3918 proteins. Based on Vaxign prediction, 11 of the 3918 proteins are cell wall proteins, 64 are extracellular proteins, and 284 are adhesins or adhesin-like proteins. Using the prediction criteria of (1) extracellular or cell wall localization, (2) adhesin probability greater than 0.51, (3) orthologs in four *M. tuberculosis* strains, and (4) no human, mouse, or pig protein similarity, 35 potential vaccine targets are returned to the user (Fig. 3, Table 3). Extracellular or cell wall proteins have more contact with the host cells and host intracellular environment; thus the antibody or cell-mediated immune responses against these proteins are likely more critical [19]. Adhesin proteins are crucial for a microbe to adhere to and invade a host cell. Therefore, an antibody against an adhesin would block the adhesin activity and prevent infection. The selection of conserved proteins would allow the vac-

Table 3
***M. bovis* Vaxign design results**

Protein name	Localization (probability)	Adhesin probability
Secreted antigen 85C	Extracellular (Prob = 1)	0.614
Heparin binding hemagglutinin HBHA	Cell wall (Prob = 1)	0.514
PE-PGRS family protein	Extracellular (Prob = 0.797)	0.723
Putative threonine rich protein	Extracellular (Prob = 0.913)	0.589
PPE family protein	Extracellular (Prob = 0.891)	0.642
PE-PGRS family protein	Extracellular (Prob = 0.797)	0.712
Periplasmic phosphate-binding lipoprotein PSTS2	Extracellular (Prob = 0.913)	0.685
PE-PGRS family protein	Extracellular (Prob = 0.797)	0.514
PE-PGRS family protein	Extracellular (Prob = 0.797)	0.716
PE family protein	Extracellular (Prob = 0.891)	0.579
Hypothetical protein Mb1300c	Extracellular (Prob = 0.913)	0.614
PE-PGRS family protein	Extracellular (Prob = 0.797)	0.732
Invasion protein	Extracellular (Prob = 0.972)	0.525
PE family protein	Extracellular (Prob = 0.891)	0.541
Hypothetical protein Mb1891	Extracellular (Prob = 0.998)	0.556
Secreted antigen 85-B	Extracellular (Prob = 1)	0.618
Immunogenic protein MPT64*	Extracellular (Prob = 1)	0.635
Hypothetical protein Mb2213c	Extracellular (Prob = 0.973)	0.546
PE-PGRS family protein	Extracellular (Prob = 0.891)	0.586
PPE family protein ^a	Extracellular (Prob = 0.797)	0.591
Low molecular weight antigen CFP2	Extracellular (Prob = 1)	0.619
Resuscitation-promoting factor RpfE	Extracellular (Prob = 0.913)	0.618
Hypothetical protein Mb2749	Extracellular (Prob = 0.891)	0.583
PE-PGRS family protein	Extracellular (Prob = 0.797)	0.721
Major secreted immunogenic protein mpb70 precursor	Extracellular (Prob = 1)	0.517
Soluble secreted antigen mpb53	Extracellular (Prob = 1)	0.604
Hypothetical protein Mb3062c	Extracellular (Prob = 0.973)	0.661
PPE family protein	Extracellular (Prob = 0.797)	0.704
Hypothetical protein Mb3521	Extracellular (Prob = 0.913)	0.694
PE-PGRS family protein	Extracellular (Prob = 0.797)	0.728

(continued)

Table 3
(continued)

Protein name	Localization (probability)	Adhesin probability
PE-PGRS family protein	Extracellular (Prob=0.797)	0.723
Secreted MPT51/MPB51 antigen protein FBPD	Extracellular (Prob=1)	0.560
Secreted antigen 85-A	Extracellular (Prob=1)	0.565
10 kDa culture filtrate antigen EsxB ^a	Extracellular (Prob=1)	0.512
6 kDa early secretory antigenic target EsaT6 ^a	Extracellular (Prob=1)	0.659

^aProteins that do not have orthologs in BCG

cine to be effective against the infection of many types of pathogens. In this case, if the selected antigen also appears in a *M. tuberculosis* strain, the resulting DNA vaccine is likely to protect against these *M. tuberculosis* strains as well. Lastly, we do not want to have a DNA vaccine antigen homologous to a host protein in order to prevent possible immune tolerance or the generation of autoimmune disease [19]. Out of the 35 potential vaccine targets generated based on the above criteria (Table 3), MTP64, Ag85A, and Ag85B are a few of the potential targets, making them interesting candidates since they have been proven valid in generating *M. tuberculosis* DNA vaccines. The other antigens can also be selected for testing, especially if we would like to identify new protective antigens not found even in *M. tuberculosis* studies. It is noted that our Vaxign analysis also found four *M. bovis* proteins that are absent in the tuberculosis vaccine BCG [20] (Table 3). How these four proteins contribute to the attenuation of BCG and possible antigenicity is unclear and deserves further investigation. The Vaxign program is computational (instead of manual) analysis, but it provides more information that must be sifted through for an accurate target protein, whereas the *M. tuberculosis* analysis provides a few targets.

Combining our plasmid and antigen analysis, it appears that an interesting potential target for a new *M. bovis* vaccine can be the gene(s) expressing *M. bovis* MTP64, Ag85A, and/or Ag85B in a pJW4303 plasmid. Many of the *M. tuberculosis* vaccines that included these antigens included other antigens as well, so other proteins could be considered for insertion based on Vaxign or *M. tuberculosis* ortholog analysis. In addition to the methods introduced here, other approaches could also be used to increase the antigen prediction accuracy and improve rational vaccine design (see Note 2).

6 Notes

1. The community-based Vaccine Ontology (VO) represents the vaccines and vaccine-related terms and the relations among these terms [6, 21]. VO includes ontological representation of all the DNA vaccines, DNA vaccine plasmids, and protective antigen genes used in these DNA vaccines [3]. Developed using the machine-processable Web Ontology Language (OWL) format [22], software programs can be developed to process the VO data for different purposes.
2. While using manual DNAVaxDB analysis and computational Vaxign prediction may provide potential target antigens and plasmids, there are ways that this analysis can be improved to increase the chances of vaccine success. Techniques such as literature mining and microarrays can quickly identify many potential targets that have shown promise in studies.

References

1. Wolff JA, Malone RW, Williams P, Chong W, Acsadi G, Jani A, Felgner PL (1990) Direct gene transfer into mouse muscle in vivo. *Science* 247:1465–1468
2. Liu MA (2003) DNA vaccines: a review. *J Intern Med* 253:402–410
3. Racz R, Li X, Patel M, Xiang Z, He Y (2014) DNAVaxDB: the first web-based DNA vaccine database and its data analysis. *BMC Bioinformatics* 15(Suppl 4):S2
4. He Y, Racz R, Sayers S, Lin Y, Todd T, Hur J, Li X, Patel M, Zhao B, Chung M et al (2014) Updates on the web-based VIOLIN vaccine database and analysis system. *Nucleic Acids Res* 42:D1124–D1132
5. He Y, Cowell L, Diehl AD, Mobley HL et al (2009) VO: Vaccine Ontology. In: The 1st international conference on biomedical ontology (ICBO-2009), Nature Precedings, Buffalo, NY, USA, 24–26 July 2009. <http://precedings.nature.com/documents/3552/version/3551>
6. Ozgur A, Xiang Z, Radev DR, He Y (2011) Mining of vaccine-associated IFN-gamma gene interaction networks using the Vaccine Ontology. *J Biomed Semantics* 2(Suppl 2):S8
7. Xiang Z, Todd T, Ku KP, Kovacic BL et al (2008) VIOLIN: vaccine investigation and online information network. *Nucleic Acids Res* 36(Database issue):D923–D928
8. Hu XD, Chen ST, Yu DH, Li SX, Cai H (2009) Immunotherapy with combined DNA vaccines is an effective treatment for *M. bovis* infection in cattle. *Vaccine* 27:1317–1322
9. Yuen CM, Kurbatova EV, Click ES, Cavanaugh JS, Cegielski JP (2013) Association between *Mycobacterium tuberculosis* complex phylogenetic lineage and acquired drug resistance. *PLoS One* 8(12):e83006
10. Buddle BM, Hewinson RG, Vordermeier HM, Wedlock DN (2013) Subcutaneous administration of a 10-fold-lower dose of a commercial human tuberculosis vaccine, *Mycobacterium bovis* bacillus Calmette-Guerin Danish, induced levels of protection against bovine tuberculosis and responses in the tuberculin intradermal test similar to those induced by a standard cattle dose. *Clin Vaccine Immunol* 20:1559–1562
11. Teixeira FM, Teixeira HC, Ferreira AP, Rodrigues MF, Azevedo V, Macedo GC, Oliveira SC (2006) DNA vaccine using *Mycobacterium bovis* Ag85B antigen induces partial protection against experimental infection in BALB/c mice. *Clin Vaccine Immunol* 13:930–935
12. Cai H, Yu DH, Tian X, Zhu YX (2005) Coadministration of interleukin 2 plasmid DNA with combined DNA vaccines significantly enhances the protective efficacy against *Mycobacterium tuberculosis*. *DNA Cell Biol* 24:605–613
13. Wang D, Xu J, Feng Y, Liu Y, McHenga SS, Shan F, Sasaki J, Lu C (2010) Liposomal oral DNA vaccine (*mycobacterium* DNA) elicits immune response. *Vaccine* 28:3134–3142
14. Elamin AA, Stehr M, Oehlmann W, Singh M (2009) The mycolyltransferase 85A, a putative drug target of *Mycobacterium tuberculosis*:

- development of a novel assay and quantification of glycolipid-status of the mycobacterial cell wall. *J Microbiol Methods* 79:358–363
15. DeVito JA, Morris S (2003) Exploring the structure and function of the mycobacterial KatG protein using trans-dominant mutants. *Antimicrob Agents Chemother* 47:188–195
 16. Yamaguchi R, Matsuo K, Yamazaki A, Abe C, Nagai S, Terasaka K, Yamada T (1989) Cloning and characterization of the gene for immunogenic protein MPB64 of *Mycobacterium bovis* BCG. *Infect Immun* 57:283–288
 17. He Y, Xiang Z, Mobley HL (2010) Vaxign: the first web-based vaccine design program for reverse vaccinology and applications for vaccine development. *J Biomed Biotechnol* 2010: 297505
 18. Garnier T, Eiglmeier K, Camus JC, Medina N, Mansoor H, Pryor M, Duthoy S, Grondin S, Lacroix C, Monsempe C et al (2003) The complete genome sequence of *Mycobacterium bovis*. *Proc Natl Acad Sci U S A* 100: 7877–7882
 19. He Y, Rappuoli R, De Groot AS, Chen RT (2010) Emerging vaccine informatics. *J Biomed Biotechnol* 2010:218590
 20. Brosch R, Gordon SV, Garnier T, Eiglmeier K, Frigui W, Valenti P, Dos Santos S, Duthoy S, Lacroix C, Garcia-Pelayo C et al (2007) Genome plasticity of BCG and impact on vaccine efficacy. *Proc Natl Acad Sci U S A* 104:5596–5601
 21. Lin Y, He Y (2012) Ontology representation and analysis of vaccine formulation and administration and their effects on vaccine immune responses. *J Biomed Semantics* 3:17
 22. W3C: OWL 2 Web Ontology language quick reference guide, 2nd edn. W3C Recommendation 11 December 2012. <http://www.w3.org/TR/owl2-quick-reference/>. Accessed 18 Feb 2015

MetaMHCpan, A Meta Approach for Pan-Specific MHC Peptide Binding Prediction

Yichang Xu, Cheng Luo, Hiroshi Mamitsuka, and Shanfeng Zhu

1 Introduction

Major Histocompatibility Complex (MHC), also known as Human Leukocyte Antigen (HLA) in human, consists of a large family of genes in most vertebrates and plays important roles in adaptive immune response. An important function of MHC molecules is to bind peptide fragments derived from pathogens and to display the peptides on the cell surface to be recognized by the counterpart T cells [1]. Biochemical validation of peptides binding to MHC molecules is expensive and time consuming; while computational approaches are much more efficient, being recognized as useful, and allow to provide only a small number of top candidates (peptides) for further experimental verification.

Recent advances of immunoinformatics allow developing many computational methods for predicting peptides which can bind MHC molecules. These computational methods can be divided into two groups: allele-specific and pan-specific methods. Allele-specific methods train models by using binding data from an allele, and the model can be applied to predict peptides binding to the allele only. In this case if the number of binders for an allele is limited, the trained model for the allele is likely to fail to give a good predictive performance. To overcome this problem, the idea of pan-specific methods is to use data from multiple alleles as input and attempt to predict binders of not only the input alleles but also other alleles. In particular, this setting must be useful for predicting binders for alleles with very few or even no known binders [2, 3].

Currently several pan-specific methods have been proposed, which invites a problem of what methods are most reliable and should be used. To overcome this issue, we develop a Web server, MetaMHCpan, an ensemble predictor using existing pan-specific

methods as component predictors. MetaMHCpan consists of MetaMHCIpan and MetaMHCIIpan, which predict peptides to bind to MHC-I and MHC-II, respectively. MetaMHCIpan uses two pan-specific methods, MHC2SKpan [4] and LApan [5] for components, while MetaMHCIIpan uses three pan-specific methods: TEPITOPEpan [6], MHC2SKpan, and LApan, and an allele-specific method: MHC2MIL [7] for components. Technically MetaMHCpan can achieve a higher predictive performance than component predictors, allowing MetaMHCpan to be current cutting-edge software on predicting peptide binders of a variety of MHC alleles.

2 Materials

The training set for MHC-I is Peters' dataset [8]. We use 35 HLA alleles and six H-2 alleles as our training alleles. Among these alleles, there are a total of 43,312 peptides, and 12,362 of them are binders. The training set for MHC-II is the dataset used by NetMHCIIpan-3.0 [9]. There are 24 DR alleles, five DP alleles, six DQ alleles, and two H-2 alleles in this dataset with totally 52,062 peptides, 20,451 of which are binders.

3 Methods

MetaMHCIpan consists of two pan-specific methods: MHC2SKpan and LApan. MetaMHCIIpan consists of three pan-specific methods: TEPITOPEpan, MHC2SKpan, and LApan, and one allele-specific method: MHC2MIL.

TEPITOPEpan is a position specific score matrix (PSSM) based method developed by extrapolating from the binding specifics of HLA-DR molecules characterized by TEPITOPE to those uncharacterized [6, 10]. The method can be divided into three steps: first, generating pseudo sequences of MHC binding pockets; then, computing the pocket similarity and weight between alleles; finally, computing PSSM. The predicted scores by TEPITOPEpan are not binding affinities.

MHC2SKpan is a kernel based method. The string kernel MHC2SK (MHC-II String Kernel) used by MHC2SKpan measures the similarities among peptides with variable lengths [4]. We use support vector regression (SVR) as the predictor. The kernel for SVR is a product of an allele kernel and a peptide kernel (MHC2SK). The predicted scores by MHC2SKpan are binding affinities.

LApan is a method that we have newly developed by extending the local alignment kernel (LA) [5] to a pan-specific method. The difference between LApan and MHC2SKpan is that the peptide kernel in LApan is LA kernel instead of MHC2SK. The predicted scores by LApan are binding affinities.

MHC2MIL is a multiple instance learning (MIL) based method by considering peptide flanking region and residue positions [7]. It is an allele-specific method and now we provide 35 alleles for prediction. Different from common supervised methods, MHC2MIL uses “bag” instead of “instance” to construct the learning unit. Each bag is mapped into a feature for SVR model with radial basis function (RBF) kernel. The predicted scores by MHC2MIL are binding affinities.

We also offer an integrated method AvgTanh [11, 12] to combine each selected method. TEPITOPEpan is a PSSM method, MHC2SKpan designs a new string kernel and MHC2MIL is a MIL based method. Since these methods are of different techniques, they complement each other and can get better results after integration. AvgTanh is an ensemble approach that the predicted score by each predictor of a test peptide will be converted into a Z-score first and then normalized by the tanh function. The final score will be the average of all normalized scores.

3.1 MetaMHCpan

MetaMHCpan is for MHC-I peptide binding prediction. The input interface is shown in Fig. 1.

1. Choose method. The default method is MHC2SKpan. Lapan is another choice. At least one of the two methods should be chosen. AvgTanh is a complement if you want (*see Note 1*).
2. Choose input format. The default input format is FASTA Format. PEPTIDE Format is another choice (*see Note 2*).
3. Enter protein sequence(s). According to the data format chosen in **step 2**, enter proper peptides. If FASTA Format is chosen, please enter a long sequence with necessary information. If PEPTIDE Format is chosen, please enter several peptides line by line. The maximum number of peptides that can be accepted by the server is 500. You can upload a file instead of entering in the text area.
4. Select peptide length. If FASTA Format is chosen in **step 2**, please select the peptide length from 9-mer to 11-mer. The default value is 9-mer. The sequence in **step 3** will be cut according the peptide length you select. If PEPTIDE Format is chosen, no peptide length should be chosen since the peptides are already entered in a proper length in **step 3**.
5. Select species and loci. For Human, HLA-A or HLA-B can be a choice. For Mouse, H-2 is a choice.
6. Select allele. According to the species and loci chosen in **step 5**, different alleles will be the candidates. For HLA-A, 19 alleles from HLA-A0101 to HLA-A6901 can be selected. For HLA-B, 16 alleles from HLA-B0702 to HLA-B5801 can be selected. For H-2, six alleles from H-2-Db to H-2-Ld can be selected.

Fig. 1 Input interface for MetaMHCpan

7. Input your MHC-I sequence. You can input your MHC-I sequence in FASTA format if previous species and alleles do not meet your demand. You can upload a file instead of entering in the text area.
8. Choose output interface. The output can be displayed on the webpage or in a text format. The default output interface is webpage. It is easy for you to read while the text format is more convenient for a computer program to analyze.
9. Click submit button. Click the submit button at the bottom of the page and your task will be in processing. You can reset all by clicking the reset bottom aside. If your task takes a little bit long time, you can input your e-mail address and the result will be sent to you by e-mail. The results are IC50 in nm. Peptides with IC50 less than 500 nm can be deemed as a binder. Rank will be displayed aside if “show rank” button is clicked (*see Note 3*).

3.2 MetaMHCIIpan

MetaMHCIIpan is for MHC-II peptide binding prediction. The input interface is shown in Fig. 2.

1. Choose method. The default methods are MHC2SKpan and LApan. MHC2MIL or TEPITOPEpan can be other choices. At least one of the four methods should be chosen. AvgTanh is a complement if you want (*see Note 1*).
2. Choose input format. The format is the same as MetaMHCIIpan (*see Note 2*).
3. Enter protein sequence(s). It is the same as MetaMHCIIpan.
4. Select peptide length. If FASTA Format is chosen in **step 2**, please select the peptide length from 9-mer to 25-mer. The default setting is 15-mer. The sequence in **step 3** will be cut according the peptide length you select.

MetaMHCpan-1.0 *A toolkit for MHC peptide binding prediction.*

Home MetaMHCIIpan **MetaMHCIIpan** Help Links Contact

Choose Predict Method
 MHC2SKpan LApan MHC2MIL TEPITOPEpan AvgTanh

Choose Input Format
FASTA Format [show an example](#)

Enter Protein Sequence(s)

Or Upload a File No file selected. [clear inputs](#)

Peptide Length
15-mer

Species/Loci
please select species/loci

Allele
please select allele

Input Your MHC-II sequence
 Enable to input one complete MHC protein sequence in fasta format
paste a single full length protein sequence of MHC alpha chain:

Or upload a file No file selected.
paste a single full length protein sequence of MHC beta chain:

Or upload a file No file selected.

Output Interface
Webpage

© 2014 DMIIIP, All Rights Reserved

Fig. 2 Input interface for MetaMHCIIpan

5. Select species and loci. For Human, one of HLA-DP, HLA-DQ, HLA-DRB1, HLA-DRB3, HLA-DRB4, and HLA-DRB5 can be a choice. For Mouse, H-2 is a choice.
6. Select allele. Different alleles are provided as a list to be chosen according to the species and loci decided in **step 5**.
7. Input your MHC-II sequence. You can input your MHC-II sequence in the FASTA format if previous species and alleles do not meet your demand. Two MHC chains should be input. They are alpha chain and beta chain. You can upload a file instead of entering in the text area.
8. Chose output interface. It is the same as MetaMHCIIpan.
9. Click submit button. Different from other methods, the result of TEPITOPEpan is not IC50 nm. They are the scores predicted by TEPITOPEpan. The rank may help you to judge the binding ability of peptides (*see Note 3*).

4 Notes

1. In MetaMHCIIpan, the score of AvgTanh is the average Tanh score of MHC2SKpan and LApan. In MetaMHCIIpan, the score of AvgTanh is the average Tanh scores of MHC2SKpan, LApan, and MHC2MIL.
2. The button, “show an example”, on the input page can give you some examples.
3. Figures 3 and 4 are output examples on webpage. The first section “Prediction Finished” shows the chosen allele and the time cost. The second section “Prediction Results” displays the results by the MetaMHCIIpan. You can choose “Plain Format” by clicking the red line “Show this Table in Plain Format” on the top of this section. The results are displayed by a table with pagination. You can choose how many entries you want in a page. The first column of table is the peptide number. The second column is the corresponding peptide. This is followed by the columns with results by different methods you have chosen. You can sort the results as you like by clicking the column names at the top of the table. You can also click the button “show rank” or “hidden rank” to show or hide the rank of predictions. “Search” function is used to search keywords such as peptide sequence.

Prediction Finished

Allele: HLA-DPA1_0103-DPB1_0201
Time cost: 5s

Prediction Results (unit:IC50)

Show this Table in Plain Format

show rank
 hidden rank
 Show entries

Search:

Pep.No	Peptide	MHC2SKpan	LAlan	AvgTanh
1	KRSLGLMGCDCTSVG	12656	10813	0.41
2	PATYGIIVPVLTSLF	420	489	0.95
3	LCKHHNGVVVNKK	23195	31163	0.5
4	LDVSVIPTSGDVVVA	5365	11222	0.74
5	LEDARRLKAIYEK	4655	7157	0.78
6	YVPLKSATCITRCNL	3371	2635	0.87
7	LPINALSNSLLRHHNL	965	1149	0.93
8	LSEDMKAFEEIKYE	417	668	0.95
9	LTTSQTLFLNIGGWV	148	246	0.97
10	LVNDRVLDILTA	3450	4313	0.85

Showing 1 to 10 of 15 entries

Previous Next

Fig. 3 Output example for MetaMHCpan

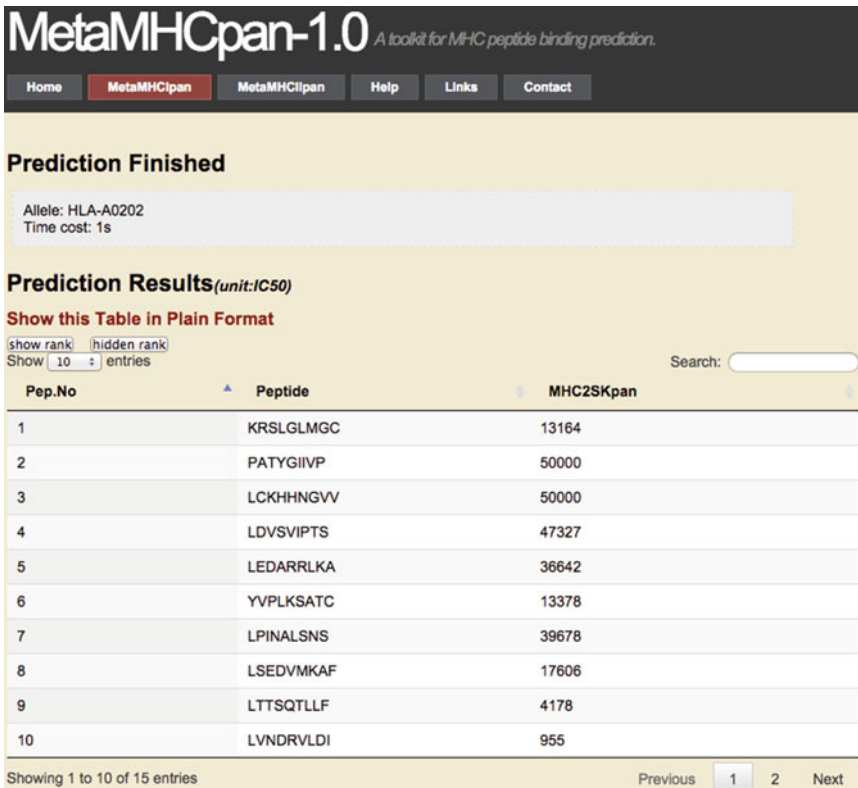

Fig. 4 Output example for MetaMHCpan

Acknowledgements

This work has been partially supported by National Natural Science Foundation of China (Grant No.: 61170097), and Scientific Research Starting Foundation for Returned Overseas Chinese Scholars, Ministry of Education, China.

References

1. Janeway JCA, Travers P, Walport M et al (2001) *Immunobiology: the immune system in health and disease*, 5th edn. Garland Science Publishing, New York
2. Zhang L, Udaka K, Mamitsuka H, Zhu S (2012) Toward more accurate pan-specific MHC-peptide binding prediction: a review of current methods and tools. *Brief Bioinform* 13:350–364
3. Zhu S, Udaka K, Sidney J, Sette A, Aoki-Kinoshita KF, Mamitsuka H (2006) Improving MHC binding peptide prediction by incorporating binding data of auxiliary MHC molecules. *Bioinformatics* 22:1648–1655
4. Guo L, Luo C, Zhu S (2013) MHC2SKpan: a novel kernel based approach for pan-specific MHC class II peptide binding prediction. *BMC Genomics* 14(Suppl 5):S11
5. Salomon J, Flower DR (2006) Predicting class II MHC-peptide binding: a kernel based approach using similarity scores. *BMC Bioinform* 7:501
6. Zhang L, Chen Y, Wong HS, Zhou S, Mamitsuka H, Zhu S (2012) TEPITOPePan: extending TEPITOPE for peptide binding prediction covering over 700 HLA-DR molecules. *PLoS One* 7(2), e30483
7. Xu Y, Luo C, Qian M, Huang X, Zhu S (2014) MHC2MIL: a novel multiple instance learning based method for MHC II peptide binding prediction by considering peptide flanking region and residue positions. *BMC Genomics* 15(Suppl 9):S9
8. Peters B, Bui HH, Frankild S, Nielsen M et al (2006) A community resource benchmarking predictions of peptide binding to MHC-I molecules. *PLoS Comput Biol* 2(6), e65
9. Karosiene E, Rasmussen M, Blicher T, Lund O, Buus S, Nielsen M (2013) NetMHCIIpan-3.0, a common pan-specific MHC class II prediction method including all three human MHC class II isotypes, HLA-DR, HLA-DP and HLA-DQ. *Immunogenetics* 65:711–724
10. Sturniolo T, Bono E, Ding J, Raddrizzani L et al (1999) Generation of tissue-specific and promiscuous HLA ligand databases using DNA microarrays and virtual HLA class II matrices. *Nat Biotechnol* 17: 555–561
11. Hu X, Zhou W, Udaka K, Mamitsuka H, Zhu S (2010) MetaMHC: a meta approach to predict peptides binding to MHC molecules. *Nucleic Acids Res* 38W:474–479
12. Hu X, Mamitsuka H, Zhu S (2011) Ensemble approaches for improving HLA class I-peptide binding prediction. *J Immunol Methods* 374:47–52

A Cohesive and Integrated Platform for Immunogenicity Prediction

Ivan Dimitrov, Mariyana Atanasova, Atanas Patronov, Darren R. Flower, and Irimi Doytchinova

1 Introduction

In silico methods developed during the last decade, as implemented in pharmaceutical research, have accelerated and optimized the process of drug discovery and development, reducing the cost of in vitro and in vivo experiments and the number of animal experiments and shortening the time from bench to bedside. As biological therapeutics have grown in importance, the need to develop in silico methods for immunogenicity prediction—which aims to mine the enormous amount of data arising from deciphered genomes and proteomes and to identify immunogenic proteins—has likewise grown in importance. While high but productive immunogenicity is essential for vaccines, therapeutic proteins and monoclonal antibodies should be minimally immunogenic.

The immunogenicity of both foreign and self-proteins is largely determined by the peptide epitopes they contain. The epitope is that part of the antigen that can be recognized by the host immune system, particularly by antibodies, B cells, or T cells. The epitopes can be categorized as conformational or linear, depending on their structure and integration with the paratope [1]. T-cell epitopes are presented on the surface of an antigen-presenting cell (APC), where they are bound to major histocompatibility complex (MHC) molecules in order to induce a T-cell-driven immune response [2]. MHCs are among the most polymorphic protein in higher vertebrates, with more than 12,000 class I and class II MHC molecules listed in IMGT/HLA [3]. Class II MHCs are expressed on specialized cell types, including professional APCs such as B cells, macrophages, and dendritic cells, whereas class I MHCs are found on every nucleated cell [4]. MHC class I molecules usually present

peptides between 8 and 11 amino acids in length, although much longer class I epitopes are now known, whereas peptides binding to MHC class II have lengths varying from 12 to 25 amino acids [5]. If appropriate quantities of the epitope are presented, a T cell may trigger an adaptive immune response specific for the pathogen.

The recognition of epitopes by T cells, and the concomitant induction of immune responses, has a key role to play within an individual's immune system. Even the slightest deviation from normal functioning may significantly impact an organism. In the case of autoimmune disease, T cells recognize the cell's native peptides as foreign, attacking, and eventually destroying the organism's own tissues. Certain viruses, such as human immunodeficiency virus (HIV), hepatitis C, avian, and swine influenza, manage to avoid recognition by the T cell by relying on mutations that alter the amino acid sequences of the proteins encoded by the virus that allows them to evade or "escape" T-cell surveillance [6, 7].

Knowledge about epitopes is vital if protein immunogenicity is to be predicted successfully. Many methods and approaches for immunogenicity and MHC binding prediction have been developed and utilized within immunology and drug development. Detailed reviews of these methods are available in the literature [8–10].

Here, we describe a cohesive platform for immunogenicity prediction developed in our labs. The platform is freely accessible and user-friendly, and it allows users to predict the immunogenicity of proteins and also MHC class I and/or II binding ability of the peptides generated from such proteins. The platform integrates three quasi-independent modular servers: VaxiJen, EpiJen, and EpiTOP. VaxiJen predicts immunogenicity of proteins of different origin; EpiJen predicts peptide binding to MHC class I proteins; and EpiTOP predicts peptide binding to MHC class II proteins. Together they represent a comprehensive suite or expert system for the prediction and delineation of protein immunogenicity.

2 Materials

2.1 *UniProt Knowledgebase (UniProtKB)*

The UniProtKB (<http://www.uniprot.org>) is part of the Universal Protein Resource (UniProt)—a database for protein sequence and annotation data. UniProtKB consists of two databases: Swiss-Prot and TrEMBL. Swiss-Prot is manually annotated and reviewed, while TrEMBL is automatically annotated and not reviewed.

2.2 *Immune Epitope Database (IEDB)*

The IEDB (<http://www.iedb.org>) contains data related to antibody and T-cell epitopes for humans, nonhuman primates, rodents, and other animal species. Curation of peptidic and non-peptidic epitope data relating to all infectious diseases, allergens, autoimmune diseases, and transplants/alloantigens is current and constantly updated.

2.3 VaxiJen

VaxiJen (<http://www.ddg-pharmfac.net/vaxijen>) is a server for the prediction of protective antigens, tumor antigens, and potential subunit vaccines [11–13]. The prediction is based on alignment-free comparison able to effectively differentiate immunogenic and non-immunogenic proteins of different origin: bacterial, viral, parasitic, fungal, and tumoral. The protein sequences are encoded by three amino acid descriptors accounting for hydrophobicity, size, and polarity. As the immunogenic and non-immunogenic proteins are of different lengths, auto- and cross-covariance transformation was used to create a defined set of uniform descriptors [14]. Two-class discriminant analysis was applied to each descriptor set and a model induced. Models were tested by internal cross-validation and external test sets. They predict by accuracy between 70 and 97 %. The VaxiJen server is widely used for identifying immunogenic proteins of different origin [15–17], and the VaxiJen score has been widely accepted as a key criterion for immunogenicity prediction [18, 19].

2.4 EpiJen

EpiJen (<http://www.ddg-pharmfac.net/epijen>) is a server for multistep class I-restricted T-cell epitope prediction [20, 21]. The algorithm mimics antigen processing in the cell: proteasome cleavage, followed by TAP transport, and binding to MHC class I proteins [4]. A protein is represented as overlapping peptides which pass consecutively through several prediction models: a model for proteasome cleavage, a model for TAP protein binding, and models for peptide binding to 18 most frequent human MHC class I proteins: A*01:01, A*02:01, A*02:02, A*02:03, A*02:06, A*03:01, A*11:01, A*24, A*31:01, A*68:01, A*68:02, B*07, B*27, B*35:01, B*40, B*44, B*51, and B*53. At each step, more non-epitopes are eliminated. The final set of peptides usually represents no more than 5 % of the initial protein sequence and contains 85 % of the true epitopes as indicated by external validation.

2.5 EpiTOP

EpiTOP (<http://www.ddg-pharmfac.net/epitop>) is a proteochemometrics tool for MHC class II binding prediction [22, 23]. Proteochemometrics is a quantitative structure-activity relationship (QSAR) approach originally developed by Wikberg et al. [24], which is specifically designed to solve QSAR problems where a set of ligands bind to a set of similar or related proteins. In a conventional QSAR analysis, the X matrix of descriptors includes only information from ligands. The proteochemometric X matrix instead also contains information from proteins. A single proteochemometrics model could potentially predict peptide binding to a whole group of MHC proteins. The EpiTOP server predicts peptide binding to 17 most frequent human MHC class II proteins: DRB1*01:01, DRB1*03:01, DRB1*04:01, DRB1*04:04, DRB1*04:05, DRB1*07:01, DRB1*08:02, DRB1*09:01, DRB1*11:01, DRB1*12:01, DRB1*13:01, DRB1*15:01,

DQA1*01:01/DQB1*0501, DQA1*01:02/DQB1*0601,
 DQA1*03:01/DQB1*0302, DQA1*04:01/DQB1*0402, and
 DQA1*05:01/DQB1*0301.

3 Methods

In the present protocol, the cohesive integrated platform described above is used to select immunogenic proteins from *Mycobacterium tuberculosis* and to predict how the peptide epitopes within them bind to MHC class I and class II proteins.

3.1 Immunogenicity Prediction

1. The UniProtKB is searched using the following keywords: mycobacterium and tuberculosis and h37rv and reviewed.
2. The results list should contain 2465 proteins of *M. tuberculosis* strain H37Rv (January 2015). Select all.
3. Download TB sequences in FASTA format.
4. Open VaxiJen (URL: <http://www.ddg-pharmfac.net/vaxijen>).
5. Select the FASTA file (**Note 1**). Select TARGET ORGANISM: Bacteria. Set THRESHOLD to 0.8. Select output as: Summary mode.
6. Press Submit.
7. The VaxiJen RESULTS page lists the VaxiJen score and the statement “Probable ANTIGEN” or “Probable NON-ANTIGEN” for each protein (Fig. 1).

VaxiJen RESULTS

Model selected: bacteria

Threshold for this model: 0.8

>sp:P9WGK3/DEVS_MYCTU Redox sensor histidine kinase response regulator DevS OS=Mycobacterium tuberculosis (strain ATCC 25618 / H37Rv) GN=devS PE=1 SV=1 Overall Antigen Prediction = **0.4270** (Probable **NON-ANTIGEN**).

>sp:P9WG29/RPFB_MYCTU Resuscitation-promoting factor RpfB OS=Mycobacterium tuberculosis (strain ATCC 25618 / H37Rv) GN=rpfB PE=1 SV=1 Overall Antigen Prediction = **0.5117** (Probable **NON-ANTIGEN**).

>sp:P9WQN5/ARC_MYCTU Proteasome-associated ATPase OS=Mycobacterium tuberculosis (strain ATCC 25618 / H37Rv) GN=mpa PE=1 SV=1 Overall Antigen Prediction = **0.4585** (Probable **NON-ANTIGEN**).

>sp:P9WI81/PKNB_MYCTU Serine/threonine-protein kinase PknB OS=Mycobacterium tuberculosis (strain ATCC 25618 / H37Rv) GN=pknB PE=1 SV=1 Overall Antigen Prediction = **0.5151** (Probable **NON-ANTIGEN**).

>sp:P9WMF9/DEV_R_MYCTU Transcriptional regulatory protein DevR (DoxR) OS=Mycobacterium tuberculosis (strain ATCC 25618 / H37Rv) GN=devR PE=1 SV=1 Overall Antigen Prediction = **0.4379** (Probable **NON-ANTIGEN**).

>sp:P9WNV3/LIGD_MYCTU Multifunctional non-homologous end joining DNA repair protein LigD OS=Mycobacterium tuberculosis (strain ATCC 25618 / H37Rv) GN=ligD PE=1 SV=1 Overall Antigen Prediction = **0.5395** (Probable **NON-ANTIGEN**).

>sp:P9WGM7/MTRA_MYCTU DNA-binding response regulator MtrA OS=Mycobacterium tuberculosis (strain ATCC 25618 / H37Rv) GN=mtrA PE=1 SV=1 Overall Antigen Prediction = **0.5915** (Probable **NON-ANTIGEN**).

>sp:P9WGI1/SIGA_MYCTU RNA polymerase sigma factor SigA OS=Mycobacterium tuberculosis (strain ATCC 25618 / H37Rv) GN=sigA PE=1 SV=1 Overall Antigen Prediction = **0.5099** (Probable **NON-ANTIGEN**).

Fig. 1 EpiJen RESULTS page for *M. tuberculosis* strain H37Rv

At threshold 0.8, the number of probable nonantigens of *M. tuberculosis* is 2381 and that for probable antigens is 84. Among the predicted antigens is the early secreted antigenic target 6 kDa (ESAT-6 or Rv3875)—a specific *M. tuberculosis* antigen—with a VaxiJen score of 0.8095. Next, we will use this protein to identify peptides binding to MHC class I and class II proteins.

3.2 MHC Class I Binding Prediction

1. Retrieve the protein sequence for ESAT-6 from UniProtKB (entry: P9WNK5) or GenBank (GI: 57117165).
2. Download or copy sequence in FASTA format.
3. Open EpiJen (URL: <http://www.ddg-pharmfac.net/epijen>).
4. Enter the protein sequence in plain format (removing the title line: delimiter >) (**Note 1**).
5. Select ALLELE: HLA-A*0201. Select proteasome cutoff of 0.1. Select TAP prediction cutoff of 5. Select output cutoff of 5 %. Press Submit.
6. The EpiJen RESULTS page lists five peptides with their starting positions, sequences, and predicted $-\log IC_{50}$ and predicted IC_{50} values in nM (Fig. 2). All of them are predicted to be high binders with IC_{50} values ranging between 1 and 10 nM.
7. As this antigen is well known, we can check the predicted HLA-A*02:01 binders in IEDB. The following settings are used: (**Note 2**)

Advanced Search/MHC Ligand Search.

Epitope: Linear peptide.

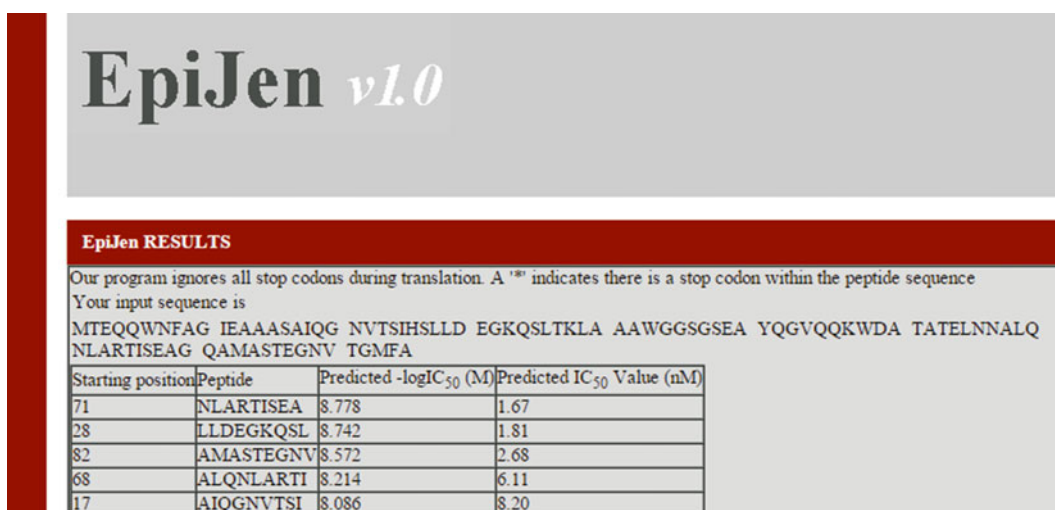

Fig. 2 EpiJen RESULTS page for *M. tuberculosis* antigen ESAT-6

Source Molecule Name: early secreted antigenic target 6 kDa;
6 KDA early secreted antigenic target; 6 kDa early secreted
antigenic target; 6 kda early secreted antigenic target.

Source Organism: *Mycobacterium tuberculosis*.

MHC Allele Name: HLA-A*02:01.

Press Search.

The search yields 11 positive epitopes and 29 positive MHC Ligand Assays, proven experimentally. The predicted five peptides are among the epitopes, as well as among the MHC binders.

8. In case of unknown antigen predicted as ANTIGEN or in case of unknown MHC binders predicted as positive binders, experiments should be performed in order to validate the immunogenicity or the MHC binding ability of the predicted protein/peptides.

3.3 MHC Class II Binding Prediction

1. The protein sequence of ESAT-6 is retrieved from UniProtKB (entry: P9WNK5) or GenBank (GI: 57117165). Download sequence in FASTA format.
2. Open EpiTOP (URL: <http://www.ddg-pharmfac.net/epitop>).
3. Enter the protein sequence in plain format (removing the title line: delimiter >) (**Note 1**).
4. Select loci: HLA-DRB1. Select threshold pIC₅₀=6.3 (by default).
5. Press “Get the result.”
6. The EpiTOP results page lists all overlapping nonamers generated from ESAT-6 protein with their starting positions, sequences, predicted pIC₅₀ values, and the number of HLA-DR alleles the peptide binds to with pIC₅₀ above the selected threshold (Fig. 3).
7. Check the predicted HLA-DRB1*01:01 binders from ESAT-6 in IEDB. (**Note 2**) The following settings are used:

Advanced Search/MHC Ligand Search.

Epitope: Linear peptide.

Source Molecule Name: early secreted antigenic target 6 kDa;
6 KDA early secreted antigenic target; 6 kDa early secreted
antigenic target; 6 kda early secreted antigenic target.

Source Organism: *Mycobacterium tuberculosis*.

MHC Allele Name: HLA-DRB1*01:01.

Press Search.

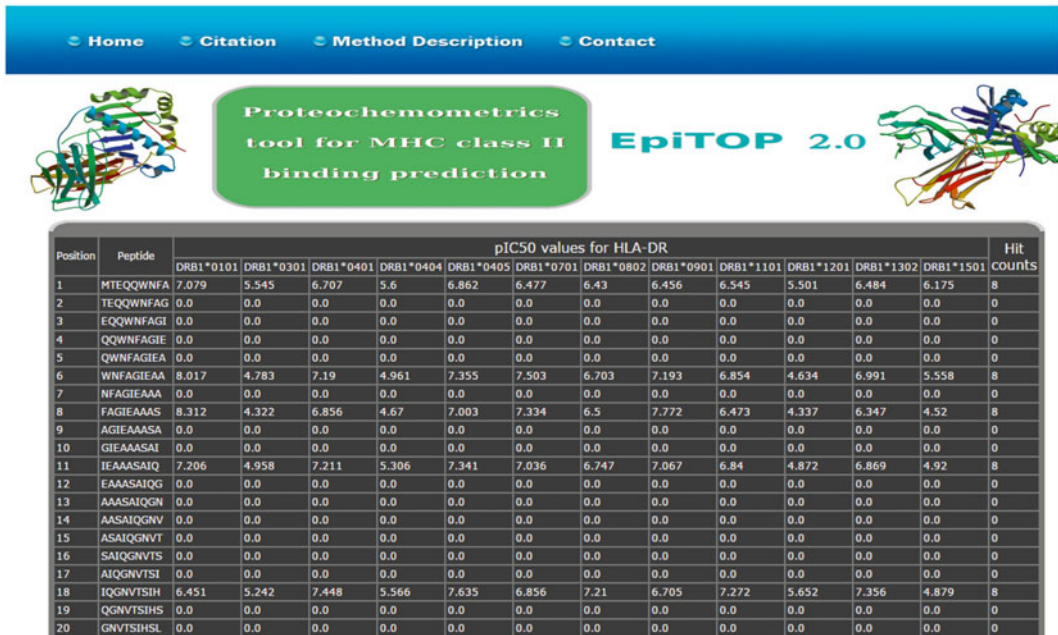

Fig. 3 EpiTOP results page (*top part*) for *M. tuberculosis* antigen ESAT-6

The search yields 22 positive MHC Ligand Assays, proven experimentally. All of them are 15mers. EpiTOP predicted 20 HLA-DRB1*01:01 binding nonamers. All of the predicted nonamers are included in the binding 15mers. By changing the MHC Allele Name, one could check for peptides binding to other DRB1 proteins.

8. In case of unknown MHC binders predicted as positive binders, experiments should be performed in order to prove the MHC binding ability of the predicted peptides.

The MHC binding nonamers originating from ESAT-6 protein are summarized in Table 1.

4 Notes

1. VaxiJen accepts multiple proteins entered in FASTA format. EpiJen and EpiTOP process single proteins entered in plain format (one-letter code).
2. The search in IEDB is case sensitive. For full search, one has to enter all possible combinations for specific terms, e.g., the molecular weight is given in kDa, KDA, or kda units.

Table 1
Summary of the MHC binders originating from *M. tuberculosis* antigen ESAT-6

Position	Peptide	pIC50 values for HLA-DR																Average pIC50	Hit counts	HLA
		DRB1* 0101	DRB1* 0301	DRB1* 0401	DRB1* 0404	DRB1* 0405	DRB1* 0701	DRB1* 0802	DRB1* 0901	DRB1* 1101	DRB1* 1201	DRB1* 1302	DRB1* 1501	DRB1* 1501	DRB1* 1501	DRB1* 1501	DRB1* 1501			
54	VQKWDATA	8.019	6.420	7.624	6.586	7.840	7.492	7.378	7.179	7.393	6.440	6.906	6.562	1.2	7.526	107024; 2001448; 2001449; 2001450; 2001451; 2001457; 2001458	DRB1*01:01; DRB1*08:02; A*02:01, A*30:02			
36	LTKLAAAWG	9.163	5.130	7.205	5.411	7.358	7.742	6.908	7.982	6.859	5.195	6.788	5.787	8	6.887	2001304; 2001305; 2001306	B*58:01			
58	WDATATELN	7.068	5.234	7.773	5.564	7.957	7.297	7.201	7.682	7.383	5.258	7.119	4.589	8	6.779	107024	DRB1*01:01; DRB1*08:02			
18	IQGNVTSIH	6.451	5.242	7.448	5.566	7.635	6.856	7.210	6.705	7.272	5.652	7.356	4.879	8	6.636	2001166; 2001167; 2001168	A*02:01			
6	WNFAGIEAA	8.017	4.783	7.190	4.961	7.355	7.503	6.703	7.193	6.854	4.634	6.991	5.558	8	6.596	161623	DRB1*01:01; DRB1*08:02			
39	LAAAWGSG	8.006	4.842	6.958	5.184	7.226	7.475	6.443	6.786	6.521	4.965	6.648	5.547	8	6.508	2001328; 2001329; 2001330; 2001331; 2001332; 2001333	A*30:02; C*07:01;			
11	IEAASAIQ	7.206	4.958	7.211	5.306	7.341	7.086	6.747	7.067	6.840	4.872	6.869	4.920	8	6.490					
28	LLDEGKQSL	8.018	4.952	6.764	4.955	6.969	7.277	6.435	6.209	6.561	4.620	6.682	6.437	8	6.452	1611682; 1611683; 2001244; 2001245; 2001246	A*02:11; A*02:12; A*02:01			
1	MTEQQWNFA	7.079	5.545	6.707	5.600	6.862	6.477	6.430	6.456	6.545	5.501	6.484	6.175	8	6.451	2001041; 2001042; 2001043	A*30:02			
22	VTSIHSLLD	7.428	5.248	6.847	5.738	6.902	6.938	6.512	7.860	6.443	5.500	6.143	4.613	7	6.398	1762154; 1952709; 1952841	A24			
72	LARTISEA3	7.600	4.929	6.914	5.089	7.097	6.945	6.355	6.781	6.537	4.842	6.428	5.531	8	6.388					

8	FAGIEAAS	8.312	4.322	6.856	4.670	7.003	7.334	6.500	7.772	6.473	4.337	6.347	4.520	8	6.342
69	LQNWRTIS	8.356	4.669	6.768	4.988	7.008	7.030	6.494	7.767	6.451	4.774	6.229	4.873	7	6.339 2001565; 2001566; 2001573 A*30:02
43	W GGSSEAY	6.881	4.381	6.791	4.557	6.951	7.020	6.285	6.483	6.481	4.156	6.671	4.938	7	6.046 2001361; 2001362; 2001369 A*30:02
76	ISEAGQAMA	7.505	4.433	6.570	4.666	6.700	6.945	6.120	6.637	6.213	4.315	6.344	5.251	6	5.977
51	YQGVQQKWD	6.768	5.453	6.519	5.795	6.777	6.245	6.030	7.395	6.148	5.625	5.718	4.789	4	5.943
65	LNNALQNW	7.063	4.329	6.309	4.447	6.418	6.528	5.855	6.401	6.018	4.144	6.216	5.200	5	5.687
83	MASTEGNVT	6.666	5.027	6.341	5.207	6.469	6.412	5.750	5.962	5.944	4.682	5.882	5.391	4	5.672
29	LDEGKQSLT	6.772	4.484	6.581	4.713	6.695	6.750	5.700	6.232	6.027	3.985	6.295	5.394	4	5.664
25	IHSLLEDEGK	6.471	3.602	5.798	3.892	5.987	5.422	5.535	6.482	5.543	3.392	5.346	3.227	2	4.823 2001221 A*30:02

References

1. Huang J, Honda W (2006) CED: a conformational epitope database. *BMC Immunol* 7:7
2. Madden DR (1995) The three-dimensional structure of peptide-MHC complexes. *Annu Rev Immunol* 13:587–622
3. Robinson J, Halliwell JA, McWilliam H, Lopez R, Parham P, Marsh SGE (2013) The IMGT/HLA database. *Nucleic Acids Res* 39:D1171–D1176
4. Janeway CA (2001) Immunobiology: the immune system in health and disease. Churchill Livingstone, New York, NY
5. Jardetzky TS, Brown JH, Gorga JC, Stern LJ, Urban RG, Strominger JL, Wiley DC (1996) Crystallographic analysis of endogenous peptides associated with HLA-DR1 suggests a common, polyproline II-like conformation for bound peptides. *Proc Natl Acad Sci U S A* 93:734–738
6. Letvin NL, Walker BD (2001) HIV versus the immune system: another apparent victory for the virus. *J Clin Invest* 107:273–275
7. Sirskiy D, Diaz-Mitoma F, Golshani A, Kumar A, Azizi A (2011) Innovative bioinformatic approaches for developing peptide-based vaccines against hypervariable viruses. *Immunol Cell Biol* 89:81–89
8. Flower DR, Macdonald IK, Ramakrishnan K, Davies MN, Doytchinova IA (2010) Computer-aided selection of candidate vaccine antigens. *Immunome Res* S2:S1
9. Patronov A, Doytchinova I (2013) T-cell epitope vaccine design by immunoinformatics. *Open Biol* 3:120139
10. Flower DR (2013) Designing immunogenic peptides. *Nat Chem Bio* 9:749–753
11. Doytchinova IA, Flower DR (2007) Identifying candidate subunit vaccines using an alignment-independent method based on principal amino acid properties. *Vaccine* 25:856–866
12. Doytchinova IA, Flower DR (2007) VaxiJen: a server for prediction of protective antigens, tumour antigens and subunit vaccines. *BMC Bioinformatics* 8:4
13. Doytchinova IA, Flower DR (2008) Bioinformatic approach for identifying parasite and fungal candidate subunit vaccines. *Open Vaccine J* 1:22–26
14. Nyström Å, Andersson PM, Lundstedt T (2000) Multivariate data analysis of topographically modified α -melanotropin analogues using auto and cross auto covariances (ACC). *Quant Struct Act Relat* 19:264–269
15. Nazarian S, Mousavi Gargari SL, Rasooli I, Amani J, Bagheri S, Alerasool M (2012) An in silico chimeric multi subunit vaccine targeting virulence factors of enterotoxigenic *Escherichia coli* (ETEC) with its bacterial inbuilt adjuvant. *J Microbiol Methods* 90:36–45
16. Maritz-Olivier C, van Zyl W, Stutzer C (2012) A systematic, functional genomics, and reverse vaccinology approach to the identification of vaccine candidates in the cattle tick, *Rhipicephalus microplus*. *Ticks Tick Borne Dis* 3:179–187
17. Rai J, Lok KI, Mok CY, Mann H, Noor M, Patel P, Flower DR (2012) Immunoinformatic evaluation of multiple epitope ensembles as vaccine candidates: *E. coli* 536. *Bioinformatics* 8:272–275
18. Gededzha MP, Mphahlele MJ, Selabe SG (2014) Prediction of T-cell epitopes of hepatitis C virus genotype 5a. *Virology* 11:187
19. Kanagavel M, Shanmughapriya S, Anbarasu K, Natarajaseenivasan K (2014) B-cell-specific peptides of *Leptospira interrogans* LigA for diagnosis of patients with acute leptospirosis. *Clin Vaccine Immunol* 21:354–359
20. Doytchinova IA, Flower DR (2006) Class I T cell epitope prediction: improvements using a combination of proteasome cleavage, TAP affinity, and MHC binding. *Mol Immun* 43:2037–2044
21. Doytchinova IA, Guan P, Flower DR (2006) EpiJen: a server for multi-step T cell epitope prediction. *BMC Bioinformatics* 7:131
22. Dimitrov I, Garnev P, Flower DR, Doytchinova I (2010) Peptide binding to the HLA-DRB1 supertype: a proteochemometric analysis. *Eur J Med Chem* 45:236–243
23. Dimitrov IP, Garnev P, Flower DR, Doytchinova I (2010) EpiTOP – a proteochemometric tool for MHC class II binding prediction. *Bioinformatics* 26:2066–2068
24. Lapinsh M, Prusis P, Gutcaits A, Lundstedt T, Wikberg JE (2001) Development of proteochemometrics: a novel technology for the analysis of drug-receptor interactions. *Biochim Biophys Acta* 1525:180–190

Part IX

Vaccine Safety and Regulation

Chapter 51

The Regulatory Evaluation of Vaccines for Human Use

Norman W. Baylor

1 Introduction

Vaccines, whether prophylactic (measles, polio, HPV, etc.) or therapeutic (HIV or other chronic infectious diseases, etc.), are subject to the same regulations as other biological products and are required to be manufactured to meet strict standards set by National Regulatory Authorities (NRA) such as the US Food and Drug Administration (FDA). While vaccine manufacturers have the primary legal responsibility for assuring the safety, quality, and effectiveness of the products they manufacture and distribute, it is the NRAs who have the legal authority of enforcement to ensure product quality, safety, and effectiveness. Moreover, NRAs are responsible for the review and authorization of clinical trials, approval of licensing applications and lot release, and monitoring the performance of the product throughout its lifecycle. The FDA also publishes guidance documents, although not legally enforceable, which provide sponsors and manufacturers with FDA's current thinking on various regulatory and scientific topics (Table 1).

Biological products, including vaccines, are distinguished from chemical pharmaceuticals primarily due to their derivation from living organisms with an innate molecular complexity that cannot be defined by physical or chemical means alone. In addition, the intrinsic variability of living organisms, and the potential for contamination of materials with adventitious agents, which may come from starting materials or the environment, requires special quality control and quality assurance mechanisms. Moreover, vaccines are inherently more difficult to develop, characterize, and manufacture than most pharmaceutical products.

The manufacture of most vaccines requires the growth or expression of the immunizing agent (i.e., bacteria, virus, virus-like particles, recombinant proteins, etc.) in living cells. Establishing the conditions

Table 1
Current guidance documents applicable to development, manufacture, licensure, and use of vaccines^a

Guidance documents
Guidance for Industry: General Principles for the Development of Vaccines to Protect Against Global Infectious Diseases (PDF—57 KB),12/2011
Guidance for Industry: Clinical Considerations for Therapeutic Cancer Vaccines, 10/2011
Guidance for Industry: Characterization and Qualification of Cell Substrates and Other Biological Materials Used in the Production of Viral Vaccines for Infectious Disease Indications, 2/2010
Guidance for Industry: Considerations for Plasmid DNA Vaccines for Infectious Disease Indications, 11/2007
Guidance for Industry: Toxicity Grading Scale for Healthy Adult and Adolescent Volunteers Enrolled in Preventive Vaccine Clinical Trials, 9/27/2007
Guidance for Industry: Clinical Data Needed to Support the Licensure of Pandemic Influenza Vaccines, 5/31/2007
Guidance for Industry: Clinical Data Needed to Support the Licensure of Seasonal Inactivated Influenza Vaccines,5/31/2007
Guidance for Industry: Development of Preventive HIV Vaccines for Use in Pediatric Populations 5/4/2006
Guidance for Industry: Considerations for Developmental Toxicity Studies for Preventive and Therapeutic Vaccines for Infectious Disease Indications, 2/2006
Guidance for Industry: FDA Review of Vaccine Labeling Requirements for Warnings, Use Instructions, and Precautionary Information, 10/1/2004
Draft Guidance for Industry: Postmarketing Safety Reporting for Human Drug and Biological Products Including Vaccines, 3/12/2001
Guidance for Reviewers: Potency Limits for Standardized Dust Mite and Grass Allergen Vaccines: A Revised Protocol, 10/2000
Guidance for Industry: Content and Format of Chemistry, Manufacturing and Controls Information and Establishment Description Information for a Vaccine or Related Product, 1/5/1999
Guidance for Industry for the Evaluation of Combination Vaccines for Preventable Diseases: Production, Testing and Clinical Studies, 4/10/1997

^aSource: Modified from FDA Vaccine and Related Biological Product Guidances. Available at: <http://www.fda.gov/BiologicsBloodVaccines/GuidanceComplianceRegulatoryInformation/Guidances/Vaccines/>

for optimization of growth and expression to obtain adequate yield is complex, and subtle changes in the process or materials can significantly affect the composition of the vaccine and its safety, effectiveness, or both. Thus, the process must be well controlled and monitored and produce a consistent, well-characterized, and reproducible product prior to its licensure. Production of the vaccine drug substance, whether by fermentation, cultivation, isolation, or synthesis, usually starts with raw materials. Subsequent steps of the procedure involve preparation, characterization, and purification of intermediates eventually resulting in the vaccine drug substance.

The vaccine drug substance is defined as the unformulated active (immunogenic) substance, which may be subsequently formulated with excipients to produce the drug product [1]. The drug substance may be whole bacterial cells, viruses, or parasites (live or killed); crude or purified antigens isolated from killed or living cells; crude or purified antigens secreted from living cells; recombinant or synthetic carbohydrate, protein, or peptide antigens; polynucleotides (as in plasmid DNA vaccines); or conjugates. The vaccine drug product is the finished dosage form of the product. The vaccine drug product contains the vaccine drug substance(s) formulated with other ingredients in the finished dosage form ready for marketing. Other ingredients, active or inactive, may include adjuvants, preservatives, stabilizers, and/or excipients. For vaccine formulation, the drug substance(s) may be diluted, adsorbed, mixed with adjuvants or additives, and/or lyophilized to become the drug product.

2 Exploratory Stage

The general stages of the development cycle of a vaccine are outlined in Table 2. The first steps are exploratory in nature. The exploratory stage involves basic laboratory research and often lasts 2–4 years [2]. The research community of academic, government, and industry scientists identifies natural or synthetic antigens that may have potential in preventing or treating a disease. These antigens could include virus-like particles, weakened viruses or bacteria, weakened bacterial toxins, or other substances derived from infectious disease pathogens. The goal of research and development at this stage is to identify and develop a viable product that is safe and immunogenic and complies with applicable regulatory requirements of the NRA of record.

Table 2
Development stages of new vaccines

Exploratory/research and development
<i>Preclinical testing</i>
In vitro and in vivo studies
<i>Clinical testing</i>
Investigational new drug application
<i>Manufacturing/quality control</i>
Chemistry, manufacturing, and control
Facility
<i>Regulatory review and approval</i>
Biologics license application

Research and discovery may be empirical and based on trial and error and occur in an unregulated environment (Fig. 1). If the vaccine shows promise in the exploratory phase, it moves on to animal testing or the preclinical phase. Although there is no regulatory oversight in the basic research and discovery phase, each of the product development stages beginning with the preclinical stage is impacted by the regulatory process. Once product development enters the regulated environment, there are challenges that must be overcome (Fig. 2). Preclinical studies must be completed according to good laboratory practices (GLP); chemistry, manufacturing, and control procedures must be done according to current good manufacturing practices (GMP); and clinical studies are required to be conducted according to good clinical practices (GCP) [3].

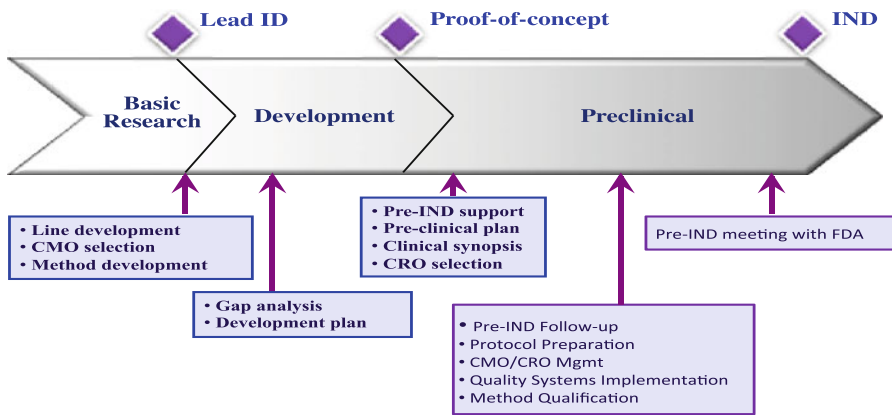

Fig. 1 Impact of the regulatory process on early product development stages. *Source:* Baylor, NW. *Regulatory Approval and Compliances for Biotechnology Products* in *Biotechnology Entrepreneurship*, Shimasaki, C. (ed.) 2014. Elsevier

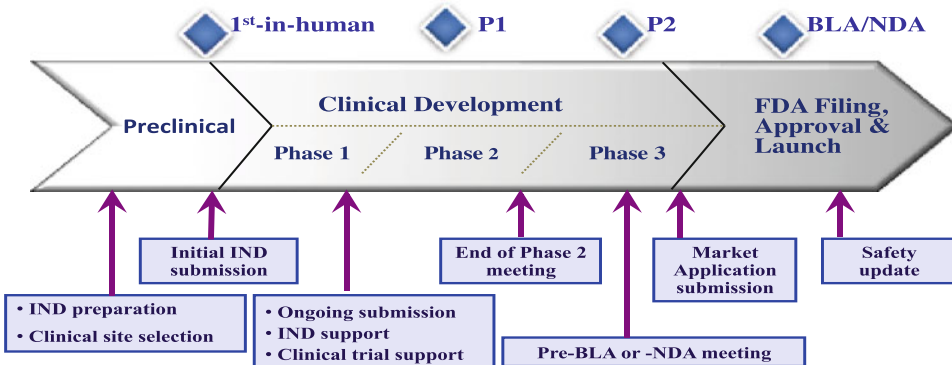

Fig. 2 Impact of regulatory process on clinical development stages. *Source:* Baylor, NW. *Regulatory Approval and Compliances for Biotechnology Products* in *Biotechnology Entrepreneurship*, Shimasaki, C. (ed.) 2014. Elsevier

3 Preclinical Stage

The preclinical stage consists of the development and testing of vaccines prior to the vaccine being tested in humans. Considerations for preclinical studies are evaluated on a product-specific basis, and requirements may differ depending on the type of vaccine, the manufacturing process, and the mechanism of action. Requirements for preclinical toxicity studies depend on considerations of the vaccine's potential benefit/risk, the target population, the available clinical data from the use of related products, the product features, and the availability of animal models. As product development proceeds, the FDA may request additional preclinical studies [4].

Early in the product development process, investigators test candidate vaccines *in vitro* prior to moving into animals. Preclinical studies use tissue culture or cell-culture systems and animal testing to assess the safety of the candidate vaccine and its immunogenicity. Animal subjects may include rodents and monkeys. These studies may also provide insight into the cellular responses expected in humans. Additionally, the outcome of these studies may also suggest a safe starting dose for the next phase of research as well as a safe method of administering the vaccine. Based on the clinical data, the candidate vaccine may be modified during the preclinical stage in an attempt to enhance the vaccine safety and effectiveness. Although limited at the beginning of clinical development, preclinical studies should be sufficient to rule out overt toxicity and identify potential toxic effects that might occur during the clinical trial. Preclinical safety studies provide important safety data on the investigational product's effects in target organs as well as the reversibility of the toxicity. Toxicity studies should be conducted in compliance with good laboratory practices (GLP) [5]. These requirements provide assurance of the validity of toxicity test results by providing a well-controlled study environment. Adequate preclinical data must be provided in the submission of an IND to the FDA in order for FDA to make a determination that the vaccine is reasonably safe to proceed with a clinical investigation.

As a consequence of more women of childbearing potential participating in clinical trials and more preventive and therapeutic vaccines being developed for adolescents and adults, NRAs have an increasing concern about the unintentional exposure of an embryo/fetus before information is available about the risk versus benefit of a vaccine. The FDA published recommendations pertaining to the assessment of the developmental toxicity potential of preventive and therapeutic vaccines for infectious diseases indicated for females of childbearing potential and pregnant females [6].

4 Clinical Testing Stage

Once the preclinical data package is reviewed and accepted by the FDA, sequential phases of clinical evaluation commence. The clinical testing stage or investigational new drug (IND) stage consists of multiple phases where the investigational product is studied in human subjects under well-defined conditions and with careful monitoring. In certain cases where studies to demonstrate efficacy in humans are not ethical or feasible, sponsors may conduct studies to demonstrate efficacy of the product in appropriate animal models. The clinical development of a new vaccine begins with the sponsor requesting permission to conduct a clinical study with an investigational product through the submission of an IND application. Title 21 CFR 312 describes the content of an original IND submission and the regulatory requirements for conduct of clinical trials under the IND regulations [6]. Clinical studies are governed by good clinical practices. These regulations facilitate the protection and safety of human subjects and the scientific quality of clinical studies [7].

The IND submission describes the vaccine, its manufacture and control testing for release of the vaccine, the proposed scientific rationale, available preclinical animal safety testing results, and a proposed clinical study protocol. Review of the IND submission allows the FDA to monitor the safety of clinical trial subjects and ensure that the study design permits a thorough evaluation of the vaccine's effectiveness and safety. There are typically three successive phases in the clinical evaluation of vaccine products under the IND regulations [8]. These phases can sometimes overlap, and the clinical evaluation may be highly iterative, because multiple phase I and II trials may be required as new data become available. The FDA rigorously oversees the clinical trial process. If data raise significant concerns about either safety or effectiveness, the FDA may request additional information or studies or may halt ongoing clinical studies.

Phase I studies are designed to evaluate vaccine safety and tolerability and to generate preliminary immunogenicity data. Typically, phase I studies enroll between 20 and 80 subjects who are closely monitored throughout the duration of the trial. Phase II studies, which typically enroll several hundred subjects, evaluate the immunogenicity of the vaccine and provide preliminary estimates on rates of common adverse events. Phase II studies are often designed to generate data to inform the design of phase III studies. Dose-ranging studies are also included in phase II clinical development. The phase III trial provides the critical documentation of the vaccine's safety and effectiveness needed to evaluate the benefit/risk relationship of the vaccine and to support licensure. Phase III trials for vaccines are large and typically enroll from several hundred to several thousand subjects to provide a more thorough assessment of

safety as well as a definite assessment of efficacy. Manufacturing reproducibility is typically addressed during the phase III trial by evaluation of lot consistency and ensuring process validation.

The general considerations for clinical studies to support vaccine licensure include safety, immunogenicity, and efficacy (immunogenicity may be sufficient in some cases). Ideally, efficacy is demonstrated in randomized, double-blind, well-controlled studies. The end points are product specific and may be clinical disease end points or immune response end points if efficacy against clinical disease has been established. The requisite number of study participants in efficacy trials for vaccines can range from thousands to tens of thousands of subjects. This broad range depends on variables such as study design and incidence of the disease to be prevented.

5 Manufacturing Stage

Vaccine manufacturing is a complex process involving analytical and formulation development to scale up the manufacturing process, finalize the formulation, and validate assays in preparation of clinical lots as well as commercial scale product (Fig. 3). A balance must be made between rapidly providing material for clinical evaluation using an interim process and delaying clinical trials until the final process, formulation, and assays are available. For each clinical trial phase, a decision must be made as to when to stop process development and establish a fixed process for the preparation of clinical materials. One solution is to prepare phase 3 clinical materials using the final process.

The process by which a vaccine is manufactured depends on the type of antigen that makes up the vaccine. There are different vaccine manufacturing processes depending on the specific type of antigen that makes up the vaccine. Many vaccine development processes, such as fermentation and cell culture, purification, formulation, analytical testing, and vaccine characterization, which precede the filing of an IND, may be done in parallel [9]. Process development can be divided into four interdependent categories: (1) process, analytical, and formulation development; (2) manufacture and testing of preclinical supplies; (3) manufacture and testing of clinical supplies (prepared according to cGMP regulations); and (4) manufacture and testing of final product for marketing authorization. In order to support clinical trials, manufacturers are expected to implement manufacturing controls that reflect product and manufacturing considerations, evolving process and product knowledge, and manufacturing experience. As the process becomes better defined, critical control points are identified and experience in the process increases; increased GMP documentation must be implemented and maintained [10].

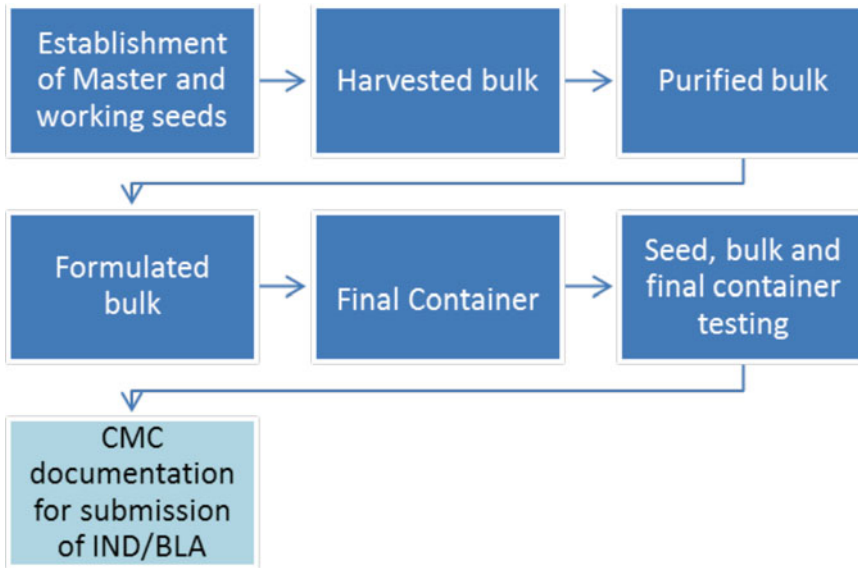

Fig. 3 Vaccine production process

The quality and purity of the vaccine drug substance cannot be assured solely by downstream testing, but depends on proper control of the manufacturing and synthetic process as well. Proper control and attainment of minimal levels of impurities depends on (1) appropriate quality and purity of the starting materials, including the seed organisms, and reagents; (2) establishment and use of in-process controls for intermediates; (3) consistent adherence to validated process procedures; and (4) adequacy of the final (release) control testing of the vaccine drug substance. Even after licensure, manufacturers conduct a series of tests on the bulk, intermediate, and final vaccine products and typically are required both to meet all product and process specifications and to submit the results of key tests, along with samples of the product to CBER for evaluation prior to CBER's approval of lot release and administration of vaccine (Table 3). The tests performed on the final product may include those for sterility, identity, purity, and potency to assess immunogenicity and/or antigen content and, depending on the nature of the vaccine and its manufacturing process, additional tests as required by the NRAs to assure vaccine safety and quality.

Vaccines, like all products that purport to be sterile, should be free of viable contaminating microorganisms to assure product safety according to FDA regulations [11]. It is not practical to demonstrate absolute sterility of a vaccine lot; however, sterility assurance is accomplished primarily by validation of the sterilization process or of the aseptic processing procedures under cGMPs. The manufacturing process must also assure that vaccines are free of extraneous material except that which is unavoidable in the

Table 3
Lot release testing

<i>Sterility:</i> bacterial or fungal contaminants
<i>General safety test:</i> guinea pigs and mice – to detect extraneous toxic contaminants
<i>Identity test:</i> e.g., SDS SDS-PAGE, Western blot, immunologic assay, or amino acid analysis
<i>Purity:</i> e.g., % moisture, SDS SDS-PAGE, HPLC, and endotoxin
<i>Potency:</i> in vivo or in vitro test to assess immunogenicity, antigen content, or chemical composition

manufacturing process. FDA regulations define purity as relative freedom from extraneous matter in the finished product, whether or not harmful to the recipient or deleterious to the product [12]. Final container vaccine is also required to be identified by a test specific for the product, e.g., neutralization of live viral vaccines with specific antisera. As far as constituent material, manufacturers must also ensure that all ingredients in vaccines such as preservatives, adjuvants, diluents, etc., meet generally accepted standards of purity.

Potency testing is also an important component of the manufacturing process. Potency is defined as the specific ability or capacity of a vaccine, as indicated by appropriate laboratory test or by adequately controlled clinical data obtained through the administration of the vaccine in the manner intended to effect a given result [13]. Potency is equivalent to the concept that the product must be able to perform as claimed, and if possible, this should correspond with some measurable effect in the recipient or correlate with some quantitative laboratory finding. Developing potency assays are product specific and present certain challenges due to the variety of vaccine types (Table 4), degree of purity, differing complexities, chemical heterogeneity of active moieties, and varying number of valencies or serotypes in some vaccines. Vaccine potency is only one of the tools used to ensure that a manufacturing process yields vaccines of quality consistent with that of lots proven efficacious [14].

Establishing analytical testing methods for vaccines and all intermediates is critical to assuring safety and consistency of manufacturing. Suitable analytical test methods are important components for establishing identity, quality, purity, and potency for a vaccine. Title 21 CFR 211.194(a) requires that test methods used for assessing compliance of pharmaceutical products, including vaccines, with established specifications must meet proper standards of accuracy and reliability. While it is not necessary to have analytical methods qualified for testing process development demonstration run materials or scale-up engineering run material, all

Table 4
Types of vaccines^a

Viral vaccines and viral vectors (e.g., polio, MMR, adenoviral vectors)
Bacterial vaccines and toxoids (e.g., DTaP)
Recombinant protein vaccines (e.g., hepatitis B and HPV)
Polysaccharide vaccines and conjugates (e.g., meningitis and pneumococcal vaccines)
DNA vaccines and gene therapy (vaccines under development)

^a*Source:* Modified from Vaccine Manufacturing Platforms, Pall Corporation. Available at: <http://www.fda.gov/BiologicsBloodVaccines/GuidanceComplianceRegulatoryInformation/Guidances/Vaccines/>

test methods need to be at least qualified for any GMP lot material during early stages of the vaccine development and manufacturing program [10]. Validation defines the performance characteristics of an analytical procedure based on the demonstration that the procedure is suitable for its intended purpose or use. Validation is generally performed in accordance with the relevant ICH guidelines. Process validation requires establishing documented evidence that provides a high degree of assurance that a specific process will consistently produce a product meeting its predetermined specifications and quality characteristics.

Vaccine production depends on living organisms, and there are many points during the manufacturing process at which to introduce contaminants. Regulatory requirements mandate that all licensed vaccines undergo appropriate lot testing before release, as listed in Table 3. Requirements for release testing of licensed biologicals can be found in Title 21 CFR 610.27. These tests include those for bacterial and fungal sterility, general safety, purity, identity, suitability of constituent material, and potency. Depending on the product, additional testing (e.g., to ensure adequate inactivation) may be required.

6 Regulatory Review and Approval

The licensing stage follows the IND stage when clinical studies are completed. Regardless of the technology used to manufacture a vaccine or the targeted population or indication, the basic regulatory requirements are the same. The regulatory review of the license application begins when a vaccine manufacturer submits a biologics license application (BLA) to the US FDA. The BLA includes data from results of clinical and nonclinical studies, as well as a complete description of manufacturing methods, compliance with cGMP requirements, data establishing stability of the product

through the dating period, samples representative of the product for introduction into interstate commerce, and data describing the equipment and facility of each location involved in the manufacture. The US FDA can approve the BLA once the agency determines that the vaccine meets prescribed requirements for safety, purity, and potency. The regulations that pertain to the licensure and submission of a BLA are in 21 CFR 600 through 680.20.

The BLA is reviewed by an expert multidisciplinary group of scientists within the FDA. In addition to review of the BLA submission, important regulatory review activities support vaccine licensure. These activities help ensure the quality and safety of licensed products. Vaccine lots are subject to pre-licensure lot-release testing. A preapproval inspection is designed as an in-depth review of the manufacturing facilities, the manufacturing process, and an assessment of the sponsor's adherence to cGMPs.

Once the FDA review committee evaluates the complete data package in the BLA, the agency generally requests that manufacturers present their data to the Vaccines and Related Biological Products Advisory Committee (VRBPAC). The VRBPAC is a standing FDA advisory committee composed of scientific experts and clinicians, consumer representatives, and a nonvoting member from industry. The VRBPAC and additional expert consultants, if needed, evaluate clinical data and comment on the adequacy of the data to support safety and efficacy in the target population. The VRBPAC's recommendations are strongly considered in the FDA's decision to license a vaccine. The VRBPAC may recommend that additional studies be performed before licensure. After FDA's review committee determines that the data in the application are satisfactory and support the safety and effectiveness of the vaccine and manufacturing consistency is demonstrated, the vaccine may be licensed.

There are several expedited review mechanisms available to the US FDA to advance the review and/or licensure of vaccines against severe and life-threatening conditions, including accelerated approval, fast track, priority review, breakthrough therapy, and emergency use authorization (EUA) (Table 5). Designation of a vaccine under these mechanisms does not lower the required scientific/medical standards, the quality of data necessary for approval, or the length of the clinical trial period.

The fast-track mechanism is designed to facilitate the development and expedite the review of new drugs that are intended to treat serious or life-threatening conditions and that demonstrate the potential to address unmet medical needs (i.e., providing a therapy when none exists) [15]. Most drugs that are eligible for fast-track designation are likely to be considered appropriate to receive a priority-review designation. A priority-review designation is given to drugs that offer major advances in treatment or provide a treatment when no adequate therapy exists. A priority review reduces the FDA review time. The time for completing a priority review is 6 months.

Table 5
US FDA expedited regulatory pathways^a

Pathway	Description of pathway ^b	Criteria	Attributes
Fast track	Program designation	Drug intended to treat a serious condition and nonclinical or clinical data demonstrate the potential to address an unmet medical need or a product designated as a qualifying infectious disease product ^c	Actions to expedite development and review; rolling review
Breakthrough therapy	Program designation	Drug intended to treat a serious condition and <i>preliminary</i> clinical evidence indicating the drug may demonstrate substantial improvement on a clinically significant end point(s) over existing therapies	Intensive guidance on efficient drug development; FDA organizational commitment; rolling review
Priority review	Program designation	An application or efficacy supplement for a drug that treats a serious condition and if approved would provide a significant improvement in safety or effectiveness ^d	Shorter review clock (6 months review time versus 10 months for standard review)
Accelerated approval	Approval pathway	A drug that treats a serious condition and generally provides a meaningful advantage over available therapies and demonstrates an effect on a surrogate end point that is reasonably likely to predict clinical benefit	Approval based on an effect on a surrogate end point or intermediate clinical end point
EUA	Approval pathway	Authorization of the use of an unapproved product or the unapproved use of an approved product when an emergency or a potential emergency exists	Allows introduction of drug, device, or biological into interstate commerce by the Sec. of DHHS for use in an actual or potential emergency

^aAdapted from the FDA Guidance for Industry: Expedited Programs for Serious Conditions – Drugs and Biologics

^bDescription of regulatory pathways includes regulatory programs such as fast track, breakthrough therapy, and priority review. Emergency use authorization and accelerated approval are mechanisms whereby products may be approved for introduction into interstate commerce

^cTitle VI11 of FDASIA, *Generating Antibiotic Incentive Now (GAIN)*, provides incentives for the development of antibacterial and antifungal drugs for human use

^dPriority review also applies to any supplement that proposes a labeling change pursuant to 505 of the FD&C Act on a pediatric study under this section or an application for a drug that has been designated as a qualified infectious disease product or an application or supplement for a drug submitted with a priority-review voucher

Breakthrough therapy is described in Section 506(a) of the FD&C Act. Breakthrough therapy provides for the designation of a drug as a breakthrough therapy “...if the drug is intended, alone or in combination with one or more other drugs, to treat a serious or life-threatening disease or condition and preliminary clinical evidence indicates that the drug may demonstrate substantial improvement

over existing therapies on one or more clinically significant end points, such as substantial treatment effects observed early in clinical development” [16]. The clinical evidence needed to support breakthrough designation is preliminary. In contrast to the data needed to support approval, as is the case for all drugs, FDA will review the full data submitted to support approval of drugs designated as breakthrough therapies to determine whether the drugs are safe and effective for their intended use before they are approved for marketing.

The accelerated-approval regulation allows approval on the basis of a surrogate end point for drugs intended to treat serious diseases and that fill an unmet medical need. A surrogate end point is a marker (e.g., a laboratory measurement or physical sign) used in clinical trials as an indirect or substitute measurement that represents a clinically meaningful outcome, such as survival or symptom improvement [17]. The use of surrogate end points may shorten the FDA approval time. Approval of a drug on the basis of such end points is given on the condition that postmarketing clinical trials verify the anticipated clinical benefit.

Emergency use authorization is another regulatory mechanism by which the US FDA can accelerate the availability of vaccines and other pharmaceutical products [18]. Under EUA the FDA can authorize the use of an unapproved product or the unapproved use of an approved product when an emergency or a potential emergency exists. Section 564(b)(1) of the FD&C Act allows the Secretary of the US Department of Health and Human Services (DHHS) to authorize the introduction into interstate commerce of a drug, device, or biological product intended for use in an actual or potential emergency. Once the Secretary of DHHS declares an emergency, the FDA may authorize the emergency use of a particular product such as a vaccine, if other statutory criteria and conditions are met.

The assessment of efficacy for some infectious disease vaccine candidates cannot be ethically conducted under clinical trial, such as those for certain bioterrorism agents. In 2002, the FDA amended the biological products regulations to incorporate 21 CFR 601.90, Approval of Biological Products When Human Efficacy Studies Are Not Ethical or Feasible [19]. This rule, referred to as the “animal rule,” provides that approval of certain new drug and biological products can be based on animal data when adequate and well-controlled efficacy studies in humans cannot be ethically conducted because the studies would involve administering a potentially lethal or permanently disabling toxic substance or organism to healthy human subjects. In these situations, certain new drug and biological products can be approved for marketing on the basis of evidence of effectiveness derived from appropriate studies in animals without adequate and well-controlled efficacy studies in humans. When assessing the sufficiency of animal data, the agency may take into account other data, including human data, available to the agency. Safety must be evaluated in humans as a prerequisite for approval.

7 Summary

Regardless of whether a vaccine is manufactured through traditional processes, i.e., live attenuated or inactivated (killed) whole organisms, or from well-defined materials, such as vaccines based on purified protein antigens of natural origin or produced by rDNA technology, polysaccharides, semisynthetic poly- or oligosaccharide-protein conjugates, and novel nucleic acid constructs, they all require strict adherence to regulatory requirements throughout the manufacturing process. It is critical for vaccine developers to have an understanding of the regulatory requirements in order to manufacture a consistent and reproducible vaccine that is safe and effective. Although the regulatory process does not directly impact the early or exploratory stages, developers must be cognizant of the requirements of the regulatory authorities, and develop a clear and focused regulatory strategy, even during the early stages of product development to avoid unnecessary delays in obtaining marketing authorization. Once a vaccine is licensed, the regulatory impact remains throughout the lifecycle of the product.

References

1. US Food and Drug Administration. Guidance for industry: content and format of chemistry, manufacturing and controls information and establishment description information for a vaccine or related product. <http://www.fda.gov/downloads/BiologicsBloodVaccines/GuidanceComplianceRegulatoryInformation/Guidances/Vaccines/ucm092272.pdf>
2. Curlin G, Landry S, Bernstein J, Gorman RL, Mulach B, Hackett CJ, Foster S, Miers SE, Strickler-Dinglasan P (2011) Integrating safety and efficacy evaluation throughout vaccine research and development. *Pediatrics* 127(Suppl 1):S1–S4
3. US Code of Federal Regulations, 21 CFR 312 (2010)
4. WHO Guidelines on Nonclinical Evaluation of Vaccines (2003) http://www.who.int/biologicals/publications/nonclinical_evaluation_vaccines_nov_2003.pdf
5. US Code of Federal Regulations, 21 CFR part 58 (2010)
6. US Food and Drug Administration. Guidance for industry: considerations for developmental toxicity studies for preventive and therapeutic vaccines for infectious disease indications. <http://www.fda.gov/downloads/BiologicsBloodVaccines/GuidanceComplianceRegulatoryInformation/Guidances/Vaccines/UCM092170.pdf>
7. International Conference on Harmonization of Technical Requirements for Registration of Pharmaceutical for Human Use. ICH harmonized tripartite guideline: guideline for good clinical practice E6(R1). <http://www.fda.gov/downloads/AnimalVeterinary/GuidanceComplianceEnforcement/GuidanceforIndustry/UCM052417.pdf>
8. US Code of Federal Regulations, 21 CFR part 312.21 (2010)
9. Janus T, Sitrin R, LeGrow K, Aunins A, Hagen A, Thornton R, Robinett R, Howson L (2003) Integrating CMC document preparation into the development process for vaccine INDs. *BioPharm International*. <http://www.biopharminternational.com/node/243807>. Accessed 22 Mar 2015
10. Conner J et al (2014) The biomanufacturing of biotechnology products. In: Shimasaki C (ed) *Biotechnology entrepreneurship*. Elsevier, Cambridge, MA, pp 351–385
11. US Code of Federal Regulations, 21 CFR 600.3(q) 2012
12. US Code of Federal Regulations, 21 CFR 600.3(r) 2012
13. US Code of Federal Regulations, 21 CFR 600.3(s) 2012
14. Meade B, Arciniega J (2001) Assays and laboratory markers of immunological importance. *Laboratory of methods development and quality control, CBER/FDA*
15. Center for Drug Evaluation and Research and Center for Biologics Evaluation and Research. Guidance for industry: fast track drug development

- programs—designation, development, and application review. US Department of Health and Human Services, Food and Drug Administration. <http://www.fda.gov/downloads/Drugs/GuidanceComplianceRegulatoryInformation/Guidances/UCM079736.pdf>
16. Sherman RE, Li J, Shapley S, Robb M, Woodcock J (2013) Breakthrough therapy (expediting drug development – the FDA's new “breakthrough therapy” designation. *N Engl J Med* 369:1877–1880
 17. US Code of Federal Regulations, 21 CFR Part 601.41 (2010)
 18. Emergency Use Authorization of Medical Products. Guidance – emergency use authorization of medical products. <http://www.fda.gov/RegulatoryInformation/Guidances/ucm125127.htm>
 19. US Code of Federal Regulations, 21 CFR Part 601.90 (2009)

Part X

Vaccine Intellectual Property

Vaccines and IP Rights: A Multifaceted Relationship

Karen Durell

1 Introduction

Just as there are many forms of vaccines and components to vaccines—particular compositions, delivery systems, components, and distribution networks—there are a variety of intellectual property (IP) protections applicable for vaccines. Often a discussion of IP rights for vaccines begins and ends with patent rights. However, patent rights are not the only IP protection applicable to vaccines. Other rights such as copyright, trademarks, plant breeders' rights, and trade secrets may also be applicable to vaccines.

For example, there is an ongoing debate regarding the ethical implications of granting patent rights for technologies and products that offer public health benefits, such as vaccines. In this debate questions are raised regarding whether patent rights have a positive or negative effect for vaccine innovation and public availability. Further questions probe whether patent rights have negative or positive effects for the development of vaccine technologies for diseases that affect the developing world in particular. This chapter acknowledges that these debates have been ongoing for years and continue to date. These are important conversations; however, it is not the aim of this chapter to add a voice to these dialogues.

This chapter will consider the types of IP rights that can play a role in the development, use, and distribution of vaccines. Right now both the ethical and practical conversations regarding IP rights and vaccines tend to concentrate on patent rights. In the toolbox of IP rights, patents grant owners a significant exclusive right that has been used by many organizations to penalize parties who attempt to copy the patented inventions. Patent rights have also been used to monopolize the market and to justify charging high fees for patent-protected products. These tactics can have

substantial negative effects for development of related technologies and access to the patented inventions. Thus, the scope and strength of patent rights have colored the discussion of IP rights generally, so that the entire category of IP rights is viewed as being capable and culpable of the same exclusionary results. In fact, patent rights are but one IP right that can be applied to a vaccine, and the high fees and limitations on access that occur due to the wielding patent rights is but one choice for the usage of IP rights by an owner.

It is further notable that the discussion surrounding IP protections for vaccines is often lost amidst the discussion of pharmaceutical products and IP rights, which generally concentrates on medicines that do not include vaccines. It is important to engage in a discussion directed to vaccines specifically, as vaccines have properties and outcomes that cause them to differ in important ways from other pharmaceutical products. Vaccines can have particular complexities to their formulation (e.g., some vaccines require skilled input into their creation), their distribution (e.g., many vaccines require cold-storage transport), and their application (e.g., injected vaccines require skilled transmission). These complexities mean that discussions of IP rights in the context of other types of pharmaceutical products may not be wholly applicable to vaccines.

Moreover, the potential scope of the societal benefits to be derived from vaccines is significant in a manner that other pharmaceutical products cannot achieve. The WHO has commented that “much of the debate on [IP rights] and public health has focused on the possible impact that patents on final products have on the prices paid in developing countries and, hence, their affordability. In the case of vaccines, the nature of their development and production and the nature of the final market may require a different kind of debate” [1]. The report goes on to cite distinctions between pharmaceuticals and vaccines, noting the following: that vaccines have much smaller markets; that the public sector has a greater involvement in the production, pricing, and marketing of vaccines; that vaccines as biological products are more complex and costly to produce; that clinical trials may also be much more costly for vaccines; and that it may be much more difficult to copy a vaccine [2]. Although these distinctions make it clear that discussion about the impact of patents upon the accessibility and affordability of vaccines may not be identical to that regarding pharmaceuticals, it is still true that both types of drugs fulfill a significant role in public health. It has been stated that “despite the 1.5 % share that vaccines have in global pharmaceutical turnover in dollars, vaccines represent much more than 1.5 % of the capacity to deal with global health problems, because they have positive externalities” [3].

News stories offer examples of the societal benefits wrought by vaccines, such as the virtual elimination of diseases and maladies

from entire communities [4]. This chapter will focus upon IP rights and vaccines specifically to highlight the unique issues of this relationship beyond those that stem from the relationship of IP rights and pharmaceutical drugs generally. There are a variety of IP rights applicable to vaccines, and each has a unique nature and offers particular possibilities to the owner thereof.

Issues of the types of vaccines that seek protection, as well as the variety of types of IP protections that are applicable to vaccines, will be discussed in this chapter. We will begin with a look at the elements and aspects of vaccines to which various IP rights may be applied and IP rights relevant thereto. After the nature of the specific IP rights applicable to vaccines has been demonstrated, we can then consider the reasons for seeking IP rights and some of the particular factors pertaining to the application of IP rights to vaccines. IP rights may be utilized in a complementary manner to effect a strategy for IP protection of vaccines that enhances both vaccine development and public availability. There are many rights in the IP toolbox, and these should all be considered in the context of vaccine creation and implementation.

2 Applying IP Protection to Vaccines

A common misconception holds that IP rights are applied to vaccines in a 1:1 ratio format. For example, such a view expects that if patent rights are applicable to vaccines, the conversation regarding the topic of IP rights applicable to vaccines is thereby ended. However, as a vaccine may comprise multiple elements and aspects, these may be protectable by different IP rights.

For example, vaccines may comprise elements that include a formulation, a device for delivery of the vaccine to a subject, a brand name whereby the vaccine is known by the public, etc. A review of the tools in the IP toolbox shows that (1) the formulation that may comprise the combination of medicinal ingredients may be protectable by patent rights; (2) the device, which may be an injection delivery system or a capsule constructed to release the vaccine in a particular area of a human body or some other form of device for delivering a vaccine, may also be protectable by patent rights; and (3) the brand name of the vaccine may be protectable by trademark. (Details regarding the applicability of such IP rights to elements and aspects of a vaccine are discussed in this chapter.)

Moreover, depending on the nature of the vaccine, additional IP rights may be utilized to protect its elements and aspects of the vaccine. An example of a vaccine that is protectable by additional IP rights is a plant-derived vaccine. This type of vaccine has been dubbed an “edible vaccine” because early research focused upon its administration through ingestion of raw plant materials to attain the immunization effect. However, further research has shown

that it is difficult to achieve consistency in dosage in an edible vaccine format. Therefore, scientists have shifted their focus to the use of dried plant-derived vaccine materials to create a product that may be administered orally, such as in the format of a pill, capsule, or powder.

Plant-derived vaccines are derived from the cultivation of genetically modified plant materials, such as a leaf, fruit, or vegetable. The genetically modified plant material has a genetic makeup that causes it to act as a vaccination upon ingestion. Examples of plant materials that have been the subject of such vaccines include potatoes, tomatoes, and bananas. Such plant materials have been genetically modified so as to be engineered to invoke an immune response to diseases such as hepatitis B surface antigens, rabies, and cholera [5].

Plant-derived vaccines are protectable by patent, but they can also enjoy the benefit of additional IP protections that some types of vaccines cannot, namely, plant breeders' rights. As discussed in more detail below, plant breeders' rights are applicable to engineered plants and therefore can be applied to the genetically modified plant element of plant-derived vaccines. Other vaccines may also enjoy the benefit of particular IP rights that are not applicable to all types of vaccines, due to their specific elements and aspects. Thus, in order to ensure that a full complement of available IP protections is provided for a vaccine, the nature, elements, and aspects of the vaccine should all be considered.

Moreover, it should be recognized that just as multiple IP rights may be applicable elements and aspects of a vaccine, there are many options for the enjoyment and usage of such IP rights. IP protection for a vaccine provides the owner(s) of such IP rights with the option to determine how the vaccine will be utilized and distributed. IP rights are exclusive rights, but it is not necessary that the IP rights be applied to exclude others from using or receiving a vaccine. In fact IP rights can be utilized to grant wide rights of use and distribution of a vaccine. Thus, IP rights do not necessarily represent a restrictive right, as they are often depicted to represent. IP rights can ensure that an owner has a scope of rights that allows for the planning of a strategy of vaccine development and public distribution tailored to the nature of the vaccine. For example, IP rights can be utilized to support broad distribution for low cost of a vaccine without being thwarted by any third party who might otherwise hinder or obstruct such a strategy.

The owner of IP rights has the option to apply their rights in the manner they perceive as best suited for the invention. Thus, there are several benefits that can be derived from IP rights—for the IP owner and public alike. The first step is recognizing which IP rights may be applicable to a vaccine.

3 Types of IP Protection

Each type of IP right is unique and each can offer particular protections and options for a vaccine. In this section, patent rights, trademarks, copyright, plant breeders' rights, and trade secrets will be reviewed in the context of applicability to vaccines. Notably, the comments relating to IP rights in this chapter specifically relate to Canadian IP laws. Generally IP laws are jurisdiction specific, and therefore the IP rights applicable in different regions and countries may vary. For example, the length of time a copyright will be enforceable and the types of subject matter to which patent rights can provide protection may have jurisdiction-specific differences. Therefore, the information provided in this chapter should be understood to provide basic comments regarding the applicability of different types of IP rights to vaccines. Guidance from a legal expert should be sought before seeking IP protections for vaccines in specific jurisdictions.

3.1 Patents

Patents provide protection for inventions. However, not all inventions are patentable. Patent laws generally protect inventions that can be described as new and useful arts, processes, manufactures or compositions of matter, or any new and useful improvement in any art, process, machine, manufacture, or composition of matter [6]. Such inventions must also fit within the categories of inventions that have been deemed patentable subject matter. For example, Canadian patent law holds that inventions that are either abstract theorems or higher life forms are not patentable [7].

Once it is established that a product, process, composition, or improvement is an invention and that it is directed to patentable subject matter, there are three additional criteria that must be met in order for patent rights to be granted. The invention must be new, it must have utility, and it must not be obvious to a person skilled in the art of the invention. Vaccine inventions (i.e., products, processes, compositions, or improvements) that meet these criteria relating to vaccines may be deemed patentable.

A patent holder is granted the exclusive right to make, construct, and use the invention and sell it to others to be used [8]. The exclusive rights are in force during a set period of time. By treaty many countries have agreed to uniformly apply a patent term that is 20 years from the filing date of the patent application [9]. (Specifically, this twenty-year term is applied by agreement of the member states of the *Trade-Related Aspect of Intellectual Property Rights* (TRIPs) agreement governed by the World Trade Organization.)

A consideration relating to patents that causes frequent consternation for an inventor is the timing for filing a patent application. This is of particular import for vaccine inventions as they are

often developed in a competitive environment. Canada, as well as many other countries, applies a first-to-file rule to patent rights. This rule holds that if two or more patent applications disclosing the same invention are filed, it is the patent application that was filed first that will be allowed to seek patent protection. As a result, it is very important that a patent application be filed as early as possible, before any competitors also file patent applications for the same invention.

There are some jurisdictions that apply first-to-invent rules. In the situation that two or more patent applications are filed for the same invention by two different parties, under first-to-invent rules, the party who proves it was the first to invent the invention will be granted the patent rights in the invention. As the market for vaccines often includes multiple jurisdictions, the first-to-file rule should be a key consideration in the timing of filing patent applications.

Another consideration is that as the scope of inventions can include products, processes, compositions, and improvements, patents can be used to provide exclusive rights for multiple elements and aspects of vaccines. For example, patent rights can protect the composition of a vaccine, the formulation of a vaccine, the process of manufacturing a vaccine, as well as the device used in the delivery of a vaccine. Protection for the composition or formulation of a vaccine may be achieved through a patent application that claims the elements that are combined to create the vaccine, such as immunogenic response-invoking components and any adjuvants. Patent rights to protect processes relating to a vaccine may be directed to a platform for the manufacture of vaccines. (As an example, some vaccines require an egg-culture process which involves a particular type of manufacture for the vaccine to be prepared.) A device for vaccine delivery can also be protected by patent rights. Such a device could include a tool for injecting a vaccine into a human, or a non-needle delivery system [10]. The foregoing are just some examples of elements and aspects of vaccines that may be protected by patent rights.

Notably, in several countries the administration of a vaccine to an individual cannot be protected if the administration is merely a medical treatment. Such countries do not allow patent rights to be granted for inventions that are medical treatments and procedures. Notably, this restriction is not uniformly imposed by all countries. Some countries do accept therapeutic or preventive methods as patentable subject matter, and in these countries, it may be possible to receive protection for vaccine administration.

In sum, when considering the patent rights that may be applied to a vaccine, it is important to view the vaccine through a lens that highlights its variant elements and aspects. Just as there is not a 1:1 ratio relationship between IP rights and vaccines, the relationship

between vaccines and patent rights can involve patent protection for more than one element or aspect of the vaccine.

3.2 Trademark

A trademark may be numbers, a word or words, a design, a symbol, or any combination of the foregoing. It is used to associate particular wares and services with a particular source organization or individual who provides such wares and services. As defined by statute, the underlying goal of a trademark is to distinguish the wares or services attributable to one source from those wares or services attributable to another source [11].

When a vaccine is made publicly available, it is rarely referenced by the Latin name of its primary component, or any other applicable scientific term. Vaccines are frequently advertised and delivered to the public under brand names. Such brand names become integrally linked to the product in the minds of the public. For example, it is rare for a member of the public to discuss a human papillomavirus vaccine, but the same person may know of the Gardasil™ vaccine. As another example, Twinrix™ is the brand name whereby a hepatitis A and B vaccine is generally known to by the public.

Brand names of vaccines can be protected as trademarks. Trademarks are generally defined as marks used by a person or company for the purpose of distinguishing wares or services manufactured, sold, leased, hired, or performed by that person or company from those manufactured, sold, leased hired, or performed by others [11]. The inherent value associated with a trademark itself lies in the goodwill that is generated through the use of the trademark over time by its owner. Due to the value garnered through continued use and goodwill associated with trademarks, many corporate entities regard their trademark portfolios to be their most valuable asset [12].

Trademarks may be registered or unregistered. Any protection granted to an unregistered mark is less extensive than that granted to a registered mark [13]. For example, the protection can be limited to the specific area where the unregistered mark was used and made known, and the mark may be required to be used in association with the wares or services for an appropriate length of time in order to demonstrate traditional trademark features like distinctiveness and exclusivity [14]. Generally owners of registered marks enjoy a fuller scope of right—the exclusive right to the use of the trademark throughout a country in respect of the wares or services associated with the mark [15]. In Canada a registered trademark is renewable every 15 years and is thus, at least theoretically, infinite in duration [16]. This potential longevity distinguishes trademarks from other forms of IP, such as patents and copyright, that have finite life-spans.

Just as there are some inventions that will not be patentable, there are certain marks that will not be registrable. In Canada, a

mark that is deemed confusing with a preexisting registered trademark is unregistrable [17]. The test that is to be applied to a comparison of potentially confusing marks reviews many aspects relating to a mark, including distinctiveness, the period of use, the nature of wares, the services and trade that the mark is used with, and the resemblance between the potentially confusing marks in appearance, sound, or ideas suggested by the marks [18]. Furthermore, the determination of confusingly similar marks is to be from the viewpoint of an average consumer. Deceptively misdescriptive marks are also deemed unregistrable.

Trademarks are an important element in how the public recognizes a vaccine. The trademark provides a link between the vaccine and the manufacturer or other provider of the vaccine. If the efficacy of a vaccine referenced by its brand name is discussed publicly, the trademark can also become a means whereby the public associates a level of quality or efficacy with a vaccine. Thus, the trademark can come to denote a level of goodwill, or a lack of goodwill, on the part of the public in relation to the vaccine.

Trademark protection can further be an important means whereby the owner of a vaccine can keep others from passing off their vaccine products as products that are provided by the owner of the branded vaccine [19, 20]. Trademark protection can also allow an owner of a mark to keep others from confusing the public about who is providing a vaccine by promoting their own products with names that are the same or similar to the registered trademark. In this manner trademark protection can provide important assistance in relation to vaccines. A trademark can be used to identify vaccines as well as to protect the public perception of the reputation, integrity, and quality of a vaccine.

3.3 Copyright

The relationship between vaccines and copyright may not be as obvious as the relationship between vaccines and patents or trademarks. Copyright is relevant to the written materials and designs—in the form of advertisements, promotional materials, articles, etc.—that support vaccines [21]. Notably, copyright protects the expression of ideas and not the ideas themselves [22]. Copyright in a work grants to an owner the sole right to produce or reproduce the work or any substantial part thereof in any material form whatever, to perform the work or any substantial part thereof in public, or, if the work is unpublished, to publish the work or any substantial part thereof.

Generally copyright is granted upon the creation of a work and thereby differs from other IP rights in that copyright does not require an application process prior to its grant. Copyright is an automatically granted right. Although there are several procedural benefits to registering copyright, one does not need to register the work or other subject matter in order to gain copyright protection.

Another unique aspect of copyright is that it crosses international borders. Whereas patent and trademark rights only exist in jurisdictions where such rights are granted, copyright will follow a work as it travels. For example, written materials relating to a vaccine existing in Canada will be governed by Canadian copyright law, whereas the same written materials existing in the USA will be governed by US copyright law.

One notable difference between the copyright laws of various countries and regions is that some jurisdictions, including Canada, specifically provide an author of a work with “moral rights” [23]. In Canada a moral right protects the author’s right to the integrity of a work or performer’s performance is infringed only if the work or the performance is, to the prejudice of its author’s or performer’s honor or reputation, (a) distorted, mutilated, or otherwise modified or (b) used in association with a product, service, cause, or institution [24]. Moral rights limit the rights of assignees and licensees of a copyrighted work to do as he or she pleases with the work.

A moral right is independent from any economic rights associated with copyright [25]. Whereas economic rights rest with the owner of the copyright, moral rights reside solely with the author of the work, irrespective of any agreement or arrangement between the author and any third party. Unlike economic rights, moral rights cannot be assigned but can be waived either in whole or in part [26]. Thus, a mere assignment of a copyright does not constitute a waiver of moral rights [27]. The term during which moral rights exist is the same as of the term of copyright in the work [28].

However, a copyright owner should be aware that the term of copyright can vary in different countries. In Canada the general term for which copyright subsists is the life of the author plus a period of 50 years thereafter [29]. In the instance that the author of a copyrightable product is not a person, the term of copyright is generally 50 years. There is no means of extending a term of copyright in Canada. Other countries apply different terms of copyright, with the result that copyright protection may exist in one country for a work, while the copyright protection for the same work has expired in another country.

Whether a work is protected by copyright is also affected by the standard for the granting of copyright applied in particular countries. In Canada copyright only subsists in a work that is original, meaning it is (1) more than a mere copy of another work and (2) the expression of an idea that is an intellectual effort achieved through the exercise of skill and judgment in a manner that is more than a mechanical exercise. In this context skill means the use of one’s knowledge, developed aptitude, or practiced ability in producing the work, whereas judgment means the use of one’s capacity for discernment or ability to form an opinion or evaluation by comparing different possible options in producing the work [30].

Other countries apply a “sweat of the brow” or “industriousness” standard of originality [31]. The result is that a work may be protected by copyright in some countries, while the same work is not protected by copyright in other countries. The determination as to whether copyright protection exists turns on the standard of copyright protection applied in each country.

Copyright can be helpful to ensure that materials and designs used in relation to a vaccine are not misused or copied by other parties. This protection can assist the owner of a vaccine to maintain and manage the provision of materials pertaining to the vaccine, so as to provide consistent and reliable information about the vaccine to the public. A copyright owner can use its rights to prohibit others from copying materials and designs and thereby exert its control. As it is critical that public information and communications relating to a vaccine be valid and reliable, copyright can be a helpful tool in relation to vaccines.

3.4 Plant Breeders' Rights

As discussed herein, vaccines that incorporate a plant element can garner plant breeders' protections. In order to be granted plant breeders' protection, a plant variety must be new, distinct, uniform, and stable [32]. A plant breeders' right holder is granted exclusive rights for 25 years in the case of a variety of tree and vine (including their rootstocks) and 20 years in the case of all other varieties of plants [33]. The owner of a plant breeder's right has the exclusive right to produce and reproduce propagating material of the variety, condition propagating material for the purpose of propagating the variety, sell propagating material of the variety, export or import propagating material of the variety, make repeated use of the protected variety as a step to commercially produce another variety (such as in the production of a hybrid), make repeated use of the protected variety for the use in the production of ornamental plants or cut flowers, stock propagating material of the variety for the purpose of doing any of the above acts, and authorize a third party to do any of the above acts, conditionally or unconditionally [34].

In Canada, the plant breeders' rights legislation was created in response to the *Pioneer Hi-Bred Ltd. v. Canada (Commissioner for Patents)* decision of the Supreme Court of Canada which held that plants were unlikely to meet the criteria for patentability in Canada [35]. The issue in *Pioneer* was whether a plant, cultivated by artificial crossbreeding of various plant varieties, was an invention under the *Patent Act*. Crossbreeding was deemed to be too close to the natural reproductive process to be patentable [36].

The plant breeders' rights legislation in Canada offers a form of protection that falls short of a patent right, although amendments to the legislation effective as of February 27, 2015 have strengthened the rights significantly. Notably, no right over the plant as a whole is granted, just the propagating materials are

protected. Its application is also curbed. For example, the PBRA does not prohibit breeders from using protected varieties to develop new plant varieties or stop farmers from maintaining seeds from a protected variety crop to grow new plants the following season. Furthermore, the PBRA Commissioner can grant a compulsory license to any person with respect to any protected plant variety in order to ensure (1) the variety is available to the public at reasonable prices, (2) the variety is widely distributed, (3) reproductive material of high quality is maintained, and/or (4) royalty rates are kept reasonable.

For vaccines that incorporate genetically modified plant materials, plant breeders' rights protection can be an important IP right. Moreover, this form of IP right can be utilized in conjunction with the other IP rights available to such a vaccine. In particular, a plant breeders' right allows an owner to prohibit other parties from copying the plant materials and utilizing such plant materials for the purpose of producing a rival vaccine.

3.5 Trade Secret

There may be elements and aspects relating to a vaccine that the owner of the vaccine will decide to keep confidential. Such elements or aspects may be difficult, or even impossible, to reverse engineer. Therefore, these elements or aspects may have particular value, because without knowledge of such elements or aspects, a vaccine cannot be replicated. As an example, a famous trade secret includes the Coca-Cola formulation. Coca-Cola exemplifies how sustaining secrecy and protective measures over trade secrets can lead to competitive advantage and potentially infinite duration on one's marketplace monopoly [37]. This example highlights the potential commercial value of products that are compositions or formulations that are difficult to replicate exactly and can therefore be effectively protected by keeping the composition a secret. Thus, trade secrets can be an important IP protection for some vaccines.

Trade secrets are used exclusively to protect information that is confidential in nature. In Canada trade secrets are a form of IP right that is protected by statute [38]. Protection measures are to be imposed on the secret. Those persons with access to the trade secret information are to be made aware of its highly sensitive nature. Many owners implement confidentiality agreements with those who are brought into contract with the secret information, including employees, co-workers, customers, licensees, and business partners.

As a class of IP rights, trade secrets are known as a relative of patent rights. Patent rights represent a bargain between an inventor and the public whereby an inventor discloses the information regarding an invention to the public and is offered exclusive rights over the invention in return. Trade secrets involve withholding information from the public and preserving a competitive advantage in the marketplace by refusing to share. In comparison to a

patent right, a trade secret is a fragile right, because once the secret is disclosed, the value of the trade secret is lost and the only compensation available to the trade secret holder is damages [38].

In some industries, patents and trade secrets are used jointly to protect elements and aspects of an invention. For example, a patent may disclose a variety of formulation options for a vaccine, but the ideal and most effective formulation may be held as a trade secret. This can create a competitive advantage in that even after a patent expires, a party who produces the vaccine may fail to produce a product that is identical to the formulation of the vaccine that is produced by the company that owns the trade secret. In particular, the copy of the vaccine may be of inferior quality or efficacy.

Due to their highly sensitive nature, trade secrets must be used cautiously. In some cases, trade secret holders will only maintain the trade secret nature for a period of time, such as during the initial phases of research and development. The strategy applied to trade secrets should be considered in light of the nature of other IP rights available for a vaccine. Where a trade secret information is highly guarded and classified and where it is resistant to reverse engineering, commercial exploitation can favor the maintenance of a trade secret [39]. Thus, trade secrets can provide effective IP protection for some types of vaccines.

4 Why Protect Vaccines with IP Rights?

As important as the consideration of the types of IP rights that may be applicable to vaccines is the determination as to why any of the available IP rights should be used to protect elements and aspects of vaccines. A primary reason for protecting vaccines is economic—vaccines are expensive to produce and obtaining some level of exclusive protection for a vaccine for a time can offer a means of recouping some of the development costs. This economic reason has further fallout in that it is possible that at least a portion of the money is generated for the vaccine owner in reliance upon exclusive IP rights or may be invested back into future research and development for other products.

As discussed above, another reason for protecting a vaccine by way of IP rights is to engage a level of control over any of the use of the vaccine, the distribution of the vaccine, public perception of the efficacy and quality of the vaccine, and the market share attained by the vaccine. Public acceptance of a vaccine can be key to the effectiveness of a vaccine's attempt to reduce the incidence of disease infection within a community. The polio vaccine is an example of a vaccine that was accepted by the public to an extent that rendered it effective in virtually eradicating a debilitating disease in multiple communities. Control of the vaccine and its many elements and aspects as is achievable through the implementation of IP rights can be key to achieving a level of communal efficacy success for a vaccine.

This is not to suggest that IP rights will allow a vaccine owner to wholly control the conversation and usage of vaccines. However, IP rights can offer some particular benefits. For example, the passing off of unregulated pharmaceutical products as brand name products is on the rise. Although many vaccines require administration by a trained person, which can avoid some of the problems that unregulated pharmaceutical products create, not all vaccines require trained administration. Vaccines, such as needle-free vaccines and capsule format vaccines, can fall prey to counterfeiting. To combat unregulated pharmaceutical products, trademark rights can be used as a mechanism to counter the use of a brand name in association with a particular vaccine by a party who does not have authorization to make such use of the trademark with such vaccine. For example, the use of the mark in association with a copy of the vaccine created by a company that is not the owner of the mark and does not have authorization from the owner of the mark can be thwarted by the measures set out in trademark legislation. Furthermore, patent rights can be used to prohibit the production of knock-off medicine products, including vaccines.

The possible outcome of failing to combat counterfeit vaccines and mislabeled vaccines is exemplified by reports of the effect of negative public perceptions relating to vaccines that have been reported upon in relation to school children [40]. Although these examples relate to a battle of research studies, it is also possible that an increasing prevalence of counterfeit and mislabeled vaccines can also lead to negative public perceptions. Such public perceptions have the propensity to result in similar outcomes, namely, the increase of the prevalence of infectious diseases among a community's child population. This includes diseases long considered to be virtually eradicated in a community. Such situations have adverse health effects at the individual and community levels.

IP protections for vaccines can further allow for a strategy of distribution and access to vaccines within jurisdictions and communities. Access to vaccines can be critical to ameliorating public health. IP rights assist a vaccine owner to plan and implement such a strategy. Factors that can be worked into such a plan include distribution and/or access to a vaccine in the developed and developing world. Considering the potential power of vaccines to change the health of communities, IP rights can be of key importance to vaccine development, distribution, access, and public acceptance rates.

5 IP Considerations for Vaccines

In addition to determinations of the type of IP rights that can be sought in relation to a vaccine, and the motivations for seeking IP rights for a vaccine, it is prudent to prepare a strategy for IP right protection for a vaccine. The creation of a plan as to which IP rights will be sought and how these will be applied invokes

additional issues in relation to vaccines. Some of these considerations are addressed in the section that follows. Notably, this discussion merely provides a few examples of such relevant considerations, namely, when to file a patent application, provisions directed to creating accessibility of vaccines in the developing world, regimes aimed at promoting IP use for humanitarian purposes, measures to protect public health, and harmonization of legislation governing IP rights and pharmaceutical products.

5.1 *When to File a Patent Application and Sound Prediction*

If patent rights are to be sought for a vaccine, in jurisdictions that apply first-to-file rules to patent applications, the decision relating to when a patent application should be filed is of critical importance. Patent rights for an invention hinge upon filing a patent application in advance of existing competitors—it is vital that a vaccine owner beats its competitors to the patent office. However, the vaccine owner must have sufficient certainty that the vaccine invention is in fact novel and nonobvious and has utility. It is the patentability factor of utility that is particularly significant in the race to the patent office. This means the patent application has to incorporate sufficient information to evidence that the invention works. Therefore, if an application is filed too early, it runs the risk of being rejected as unpatentable due to a lack of utility.

In some countries, such as Canada, a patent application can be filed at the point in time when the inventor can soundly predict that the vaccine technology will work for a particular purpose [41]. This means that an inventor can file a patent application before the final version of the vaccine is developed. In accordance with Canadian jurisprudence, a sound prediction must be more than a lucky guess or mere speculation. The Supreme Court of Canada has set out three requirements for a sound prediction: (1) there must be a factual basis for the prediction; (2) at the patent application filing date, the invention must have a sound line of reasoning from which the desired result can be inferred from the factual basis; and (3) proper disclosure must be provided in the patent application supporting the sound prediction. Allowing for patent applications to be filed based upon a sound prediction is understood to balance the public benefit of early disclosure before the utility of the invention has been fully verified with the rights of the patent holder.

5.2 *Vaccine IP and Accessibility in the Developing World*

Some vaccines may have specific characteristics or uses that lend them to being of particular assistance to the use in the developing world. For example, several characteristics of plant-derived vaccines in particular cause them to have specific benefits for developing nations, such as vaccine materials that may be propagated quickly, in large quantities, at a low cost, and that may be easily transported even to remote areas. These qualities suggest that issues, such as access and affordability, that hinder the application

of many existing medicines in developing nation environments in particular may be overcome by such vaccines. Although plant-derived vaccine innovations are owned by developed world researchers and organizations, they may ultimately be applied primarily in developing nation environments.

Notably, there is a concern that strong IP rights, patent rights in particular, may negatively affect the accessibility of vaccine technologies in developing nations because they foster the monopolization of marketplace sectors and in turn inflate prices [42]. Although patent rights are not the only barrier to access to medicines in developing nations—infrastructure and investment also play a role—right holders' activities can exacerbate the problem [43]. In the words of one commentator, support for innovation should be put into perspective as it is “a leap of faith for investors in industrialized countries; imagine how hard it is in countries where R&D expenditures may be only a fraction...of gross national product, skilled and educated labor is at a premium, intellectual turf wars stifle collaboration, economic difficulties and inflation are rampant, venture capital investors are an unknown species, intellectual property protection is murky and political turmoil is a frequent backdrop” [44]. Although an exact price tag has not been attached to the cost of bringing a new vaccine into the public sector in developing countries, it is estimated that in the case of a hepatitis B vaccine, “from first licensure in a developed country, it can take an additional 10–15 years or more and substantial financial resources to introduce such a vaccine into significant numbers of developing country national immunization programs” [45]. This means committed funding over a long period is required. Many commentators agree that patent rights must be part of the solution [46]; what is unclear is the strength of the patent rights that must be granted.

Many partnerships [47] and major global funds [48] have been formed to work on the issues relating to vaccine implementation in developing nations. Simultaneous with these developing nation programs, developed nation efforts on vaccine production have taken on greater significance in light of concerns about the potential for pandemics [49]. Although no clear solutions have emerged as of yet regarding how to most effectively apply vaccines internationally, the issue of IP rights is of primary concern in the context of the debate. This is particularly true in developing nations that are plagued with preventable diseases. A fact that may greatly influence any solution regarding the force of IP rights over vaccine products is the TRIP provisions for least-developed countries (“LDCs”).

5.3 TRIPs and LDCs

Article 66 of TRIPs directly addresses IP rights to be applied in LDCs. Specifically the article exempts LDCs from compliance with most of the provisions of TRIPs due to “their economic, financial

and administrative constraints, and their need for flexibility to create a viable technological base” [50]. This is not an exemption for all time, but for a term of 10 years from the date when the state becomes a member country, with the possibility of a further extension period upon request [51]. Hand in hand with the LDC exemption in TRIPs is an admonition to developed nations to create incentives for corporations within their borders to engage in technology transfers to LDCs, “in order to enable [LDCs] to create a sound and viable technological base” [52].

Thus, the effect of article 66 is that LDCs are granted a reprieve from implementing national IP regimes for a time. This is both good and bad for LDCs. Because an LDC does not have to grant IP protection, copying of inventions is permissible and market monopolies may be averted. However, one of the reasons why LDCs have been granted an exception from TRIPs is because they lack the financial and scientific infrastructure to produce and support innovation internally. Therefore, LDCs need to import innovations from other countries [45]. It can be difficult to attract national investment if the LDC cannot offer market returns, which are normally gleaned due to market monopoly made possible by exclusive patent rights. The result is a vicious circle. LDCs are not required to have patent regimes in place because they do not create innovation due to the fact that they lack the infrastructure—laboratories, trained scientific staff, sophisticated equipment, etc.—to do so [53]. Consequently, LDCs fail to attract the investment necessary to build an internal infrastructure because they do not offer the benefits of national patent rights to investors [54]. The cycle is self-perpetuating.

So, on the one hand national patent rights cannot hinder access to vaccines in LDCs because they do not exist, but on the other hand the lack of patent rights may pose a barrier to access to vaccines in LDCs since the vaccines must be imported from developed nations where patent rights are offered. The imported vaccines are likely sold at a premium price as a result of the patent rights. Moreover, since pharmaceutical companies cannot attain patent rights for their products and processes in LDCs, there is a lack of interest in facilitating the production of vaccines within LDCs. Copying of vaccines may be permissible in LDCs, but at the same time it is impossible for LDCs to undertake an initiative to copy a vaccine due to a lack of sophisticated infrastructure [55]. In sum, despite the TRIP exception, patent rights are not meaningless for LDCs.

5.4 Vaccines and Humanitarian Purposes

Individual countries have made attempts to address the possible negative outcomes that exclusive IP rights over pharmaceutical products can have for public health. For example, to address the use of patents for pharmaceutical products to address public health problems afflicting developing and least-developed

countries, especially those resulting from HIV/AIDS, tuberculosis, malaria, and other epidemics, the Canadian patent legislation was amended to incorporate provisions whereby a compulsory licensing mechanism is set up. This system was created to address national emergencies or other situations of extreme urgency, in countries that have no, or insufficient, pharmaceutical capacity to manufacture a pharmaceutical product of a particular dosage in quantities to address the emergency. The regime would allow for the production of such pharmaceutical products that are protected by patent in Canada for the purpose of addressing the emergency solely. The produced pharmaceutical products, that by definition include vaccines, would explicitly not be used for commercial purposes.

Vaccines are one of the technologies upon which research to address these types of health issues is focused. Therefore, mechanisms incorporated in the Canadian patent legislation could be engaged in relation to a vaccine. To date this mechanism has not achieved distribution of a patented medicine under compulsory license. In fact, only two attempts to utilize the mechanism appear on the public list of applications to invoke the mechanism. An application requesting a right to produce and export a patented pharmaceutical product under the mechanism was first filed by the generic drug producer Apotex in 2007 and renewed in 2009. Low use of the mechanism is likely related to several barriers the implementation of the compulsory license has encountered, including challenges by World Trade Organization member states. This has thwarted the ambitions of the regime. Thus, as of the date of this publication, the mechanism has not been able to produce the alleviation of humanitarian challenges through provision of pharmaceutical products under compulsory license that it was created to achieve.

As another example, the USA has introduced an IP application regime whereby owners of IP that is directed to a humanitarian purpose may receive benefits. Specifically, the US Patent and Trademarks Office offers a Patents for Humanity Program. This program invites the submission of applications that describe how a patented technology or product has been used to address humanitarian challenges for the less fortunate [56]. There are five categories of global challenges for competition by the applicants. Winners are awarded a certificate that can be redeemed to accelerate certain matters before the US Patent Office. The certificate can be applied to expedite a patent application, an *ex parte* reexamination, or an *ex parte* appeal to the Patent Trial and Appeal Board. Thus, the program incentivizes patent owners to use granted patents to address humanitarian challenges. Notably, medicine is one of the identified categories of global challenges, and this category is specifically defined to include vaccines.

5.5 Protection of Public Health

At the international level, countries have entered into treaties that incorporate certain provisions directed to the protection of public health. The application of pharmaceutical products, including vaccines, to public health is a topic in developing nations as well as developed nations. TRIPs include provisions directed to applying the remedy of compulsory licensing in the instances of either “national emergency or extreme urgency,” wherein the invention will be applied to a “public noncommercial use” [57].

Article 27.2 that recognizes exclusions to patentability or commercial exploitation may be upheld for the purpose of protecting *ordre public* or morality. This provision is interpreted as expressly extending to the protection of health. In reliance upon article 27.2, a country may deem certain subject matter non-patentable for the purpose of protecting health. Such subject matter could include vaccines or other pharmaceutical drugs. Thus, this section is of note because upon its face it opens the door for significant amendments to the definition of patentable subject matter, in the name of protecting health.

Moreover, section 8 of TRIPs addresses “measures necessary to protect public health” directly. At the very least, articles 8 and 27.2 open the door to the possibility that any patent related to health care is being subjected to an exemption founded upon *ordre public* or morality. If these exemptions are invoked for a vaccine invention, the patent holder’s rights may be diminished if not annihilated. Notably, if used extensively these provisions may have the effect of weakening the force of the presumption of the exclusive rights of IP protections for vaccine patents.

5.6 Links between Patent and Drug Legislation

In order to address the unique issues surrounding pharmaceutical products, including vaccines, the drug and patent regimes in some countries have been attuned one to another so that they may function harmoniously. Specifically, vaccines fit within such a regime in the categories of injectable and biologic. In particular, it is the biological nature of vaccines that distinguishes them from other types of medical treatments, such as medicines comprised of chemical compounds. Vaccines are included in the category of biologics by the US Food and Drug Administration and are given the following definition: “Biologics, in contrast to drugs that are chemically synthesized, are derived from living sources (such as humans, animals, and microorganisms). Most biologics are complex mixtures that are not easily identified or characterized, and many biologics are manufactured using biotechnology. Biological products often represent the cutting-edge of biomedical research and, in time, may offer the most effective means to treat a variety of medical illnesses and conditions that presently have no other treatments available” [58].

In Canada, to help curb fears and calm emotions, which are indivisible from health issues, previously separate legislative efforts

are now linked through cooperative legislation, namely, the *Patent Act*, the *Food and Drugs Act* (the “F&D Act”), and the *Patented Medicines (Notice of Compliance) Regulations* (the “NOC Regulations”) [59, 60]. Under the *Patent Act*, exclusive patent rights may be granted over new vaccines in relation to a specific practical application or disease [61]. Once a vaccine patent is granted, a further step must be taken prior to introducing the drug to the marketplace. It must be approved in accordance with the F&D Act. To aid in this process, and as part of the integration of the patent regime and the food and drugs regime, the minister will issue a notice of compliance (“NOC”) once the vaccine is ascertained to be safe and effective. Prior to the issuance of an NOC, a vaccine may not be advertised or sold in Canada. In order to obtain an NOC, a new vaccine submission must be supported by a detailed compilation of information, data, and research, including information about any patent issued for the vaccine.

Cooperation between the food and drug regime and the patent regime ensures that the term of a patented vaccine is respected. In particular, generic drug manufacturers are prohibited from attempting to introduce an equivalent drug into the marketplace during the patent term [62]. The effect of the cooperative effort is that “the NOC Regulations introduce patent considerations into the regulatory approval process” [62]. The link between the patent regime and the food and drug regime will affect IP protection choices for vaccines.

6 Conclusion

Although the conversation about the relationship between vaccines and IP rights has traditionally been limited to a discussion about patent rights, the topic has a wider scope of copyright, trademarks, patents, trade secrets, and possibly even plant breeders’ rights. Moreover, this broadened discussion introduces considerations that have not been previously routinely engaged in relation to IP rights and vaccines. A view that recognizes the applicability of multiple IP rights to the various elements and aspects of vaccines not only can provide an ultimately wider scope of IP protection to vaccines, it can further allow for the development of a strategy that benefits from the integration and cooperation of IP rights for vaccines.

Thus, discussion of IP rights and vaccines should not begin and end with the application of one IP right to a vaccine. The discussion should engage considerations of multiple IP rights applicable to a vaccine and how these can be utilized in an integrated manner to support the development and distribution of the vaccine. This integrated view further permits for a strategy to be devised, and the contemplations as to why particular IP rights

should be included in the strategy and considerations that may affect various IP protections for vaccines can be reviewed in light of the strategy, rather than in view of individual IP rights for vaccines. The result is a more productive and conclusive strategy that can be identified. Therefore, as a view of vaccines as engaging multiple IP rights can change the strategy for the development and distribution of vaccines immensely, the discussion needs to be re-focused to recognize the toolbox of IP rights available to vaccines.

References

1. WHO, "Intellectual Property Rights and Vaccines in Developing Countries" WHO /IVB/04.21, 2004 at 4
2. WHO, "Intellectual Property Rights and Vaccines in Developing Countries" WHO /IVB/04.21, 2004 at 4-5
3. WHO, "Intellectual Property Rights and Vaccines in Developing Countries" WHO /IVB/04.21, 2004 at 6
4. Griffith-Greene, Megan, "Vaccines: Busting common myths", CBC, (27 Nov 2014) at: <http://www.cbc.ca/news/health/vaccines-busting-common-myths-1.2851270>
5. Canadian Patent Application No. 2,321,260, filed October 12, 2000
6. *Patent Act*, R.S.C. 1985, c P-4, s. 2
7. *Patent Act*, R.S.C. 1985, c P-4, s. 27(8); *Harvard College v. Canada (Commissioner of Patents)*, [2002] 4 SCR 45; *Monsanto Canada Inc. v. Schmeiser*, [2004] 1 SCR 902
8. *Patent Act*, R.S.C. 1985, c P-4, s. 42
9. *Patent Act*, R.S.C. 1985, c P-4, s. 43
10. <http://www.vaxxas.com/nanopatch-technology/benefits>. Nanopatch™ is an example of a non-needle vaccine delivery system, comprising a patch incorporating an array of nanoprojections that directly delivers a vaccine to immune cells
11. *Trade-marks Act*, R.S.C. 1985, c. T-13, s.2
12. Financial World, August 2, 1994
13. *Kirkbi AG v. Ritvik Holdings Inc.*, 2005 CarswellNat 3631 at para. 30
14. *Kirkbi AG v. Ritvik Holdings Inc.*, 2005 CarswellNat 3631; see also *Kirkbi AG v. Ritvik Holdings Inc.*, 2003 CarswellNat 2175
15. *Trade-marks Act*, R.S.C. 1985, c. T-13, s.19
16. *Trade-marks Act*, R.S.C. 1985, c. T-13, s.46
17. *Trade-marks Act*, R.S.C. 1985, c. T-13, s.12 (1)(d)
18. *Mattel U.S.A. Inc. v. 3894207 Canada Inc.*, 2006 CarswellNat 1400 at para. 51; see also *Canadian Tire Corp. v. Accessoires d'autos Nordiques Inc.*, 2007 CarswellNat 3988 at para. 25. *Trade-marks Act*, R.S.C. 1985, c. T-13, s.6(5)
19. *Perry v. Truefitt* (1842), 6 Beav. 66, 49 E.R. 749 cited with approval in *Ciba-Geigy Canada Ltd. v. Apotex Inc.*, 1992 CarswellOnt 1007, Supreme Court of Canada at 30
20. *Ciba-Geigy Canada Ltd. v. Apotex Inc.*, 1992 CarswellOnt 1007, Supreme Court of Canada at 33
21. *Copyright Act*, R.S.C. 1985, c. C-42, s. 2
22. *CCH Canadian Ltd. v. Law Society of Upper Canada*, 2004 SCC 13, [2004] 1 S.C.R. 339 at para. 8
23. *Copyright Act*, R.S.C. 1985, c. C-42, s. 2, s.14.1 and s. 17.1
24. *Copyright Act*, R.S.C. 1985, c. C-42, s. 28.2(1)
25. *Théberge v. Galerie d'Art du Petit Champlain inc.*, [2002] 2 S.C.R. 336
26. *Copyright Act*, R.S.C. 1985, c. C-42, s. 14.1(2) and s. 17.1(2)
27. *Copyright Act*, R.S.C. 1985, c. C-42, s. 14.1(3) and s. 17.1(3)
28. *Copyright Act*, R.S.C. 1985, c. C-42, s. 14.2(1), s. 14.2(2), s. 17.2(1) and s. 17.2(2)
29. *Copyright Act*, R.S.C. 1985, c. C-42, s. 6
30. *CCH Canadian Ltd. v. Law Society of Upper Canada*, 2004 SCC 13, [2004] 1 S.C.R. 339 at para. 16
31. *CCH Canadian Ltd. v. Law Society of Upper Canada*, 2004 SCC 13, [2004] 1 S.C.R. 339 at paras. 22 to 25
32. Morin E (1997) Of mice and men: the ethics of patenting animals. *Health Law J* 5:147-197; *Plant Breeders' Rights Act*, R.S.C. 1990, c. 20 at s. 4
33. *Plant Breeders' Rights Act*, R.S.C. 1990, c. 20 at s. 6
34. *Plant Breeders' Rights Act*, R.S.C. 1990, c. 20 at s. 5.2
35. *Pioneer Hi-Bred Ltd. v. Canada (Commissioner for Patents)* [1989] 1 S.C.R. 1623

36. *Calgon Carbon Corporation v. City of North Bay*, [2005] F.C. 838
37. *AFX International Focus*. The Week's Business: Coca Cola caper, 7 July 2006
38. *Lac Minerals v. International Corona Resources*, [1989] 2 S.C.R. 574
39. Isaacs R (2004) How not to tell all: Find out how to preserve the company's competitive edge by preventing proprietary information from being given away. *Security Mgmt* 102
40. Johnson L (2015) Mandatory childhood vaccinations supported by majority in B.C. and Alberta: poll" (9 June 2015) CBC at <http://www.cbc.ca/news/canada/british-columbia/mandatory-childhood-vaccinations-supported-by-majority-in-b-c-and-alberta-poll-1.3106259>
41. *Apotex Inc. v. Wellcome Foundation Ltd.*, [2002] 4 S.C.R. 153, 2002 SCC 77
42. Mahoney RT et al (2004) The introduction of new vaccines into developing countries III. The role of intellectual property. *Vaccine* 22:786–792
43. Kapczynski A et al (2005) Addressing global health inequities: an open licensing approach for university innovations. *Berkley Tech Law J* 20:1031
44. Marshall A (2004) Open secrets. *Nat Biotechnol* 22:DC1
45. Mahoney RT, Maynard JE (1999) The introduction of new vaccines into developing countries. *Vaccine* 17:646–652
46. Morel C et al (2005) Health innovation in developing countries to address diseases of the poor. *Innov Strat Today* 1:1–15; Mahoney RT et al (2004) The introduction of new vaccines into developing countries III. The role of intellectual property. *Vaccine* 22:787; and Royal Society of London et al (2000) Transgenic plants and world agriculture. National Academy Press, p 12, <http://books.nap.edu/html/transgenic> at 29
47. International AIDS Vaccine Initiative, the International Partnership for Microbicides, the Medicines for Malaria Venture, Malaria Vaccine Initiative, and the Global Alliance for TB Drug Development; Morel C et al (2005) Health innovation in developing countries to address diseases of the poor. *Innov Strategy Today* 1:1–15
48. Vaccine Fund, of Global Alliance for Vaccines and Immunizations and the Global Fund to Fight AIDS, Tuberculosis and Malaria
49. Fedson DS (2005) Preparing for pandemic vaccination: an international policy agenda for vaccine development. *J Public Health Policy* 26:4–29; and Barrett CL et al (2005) If small-pox strikes Portland. *Scientific American.com*, <http://www.scientificamerican.com/article.cfm?chanID=sa006&colID=1&articleID=000BBC08-CEA3-1213-8EA383414B7FFE9F>
50. Article 66(1) of TRIPs
51. TRIPs Council Agreements on Extension for LDCs on Pharmaceutical Patents. *Bridges* 6(25): 3 July 2002, <http://www.ictsd.org/weekly/02-07-03/story1.htm>
52. TRIPs, article 66(2)
53. Royal Society of London et al (2000) Transgenic plants and world agriculture. National Academy Press. <http://books.nap.edu/html/transgenic>
54. Mahoney RT, Ramachandran S, Xu Z (2000) The introduction of new vaccines into developing countries II. Vaccine financing. *Vaccine* 18:2625–2635
55. Ragavan S (2003) Can't we all get along? A case for a workable patent model. *Ariz State Law J* 35:117
56. Patents for Humanity, <http://www.uspto.gov/patent/initiatives/patents-humanity/patents-humanity-program-info>
57. Section 19.1(2) of the *Patent Act*, and article 31 of TRIPs
58. U.S. Food and Drug Administration, Centre for Biologics Evaluation and Research, "About Us", <http://www.fda.gov/cber/about.htm>
59. R.S.C. 1985, c. F-27
60. *Jean Chrétien Pledge Pledge to Africa Act*, given royal assent May 14, 2004
61. Scassa T (2001) Patents for second medical indications and their potential impact on pharmacare in Canada. *Health Law J* 9:23–59. *Shell Oil Co. v. Commissioner of Patents*, [1982] 2 S.C.R. 536
62. *Aventis Pharma Inc. v. Novopharm Limited*, [2005] F.C. 815

From the Bench to the Pharmacy: Protecting Innovation During Vaccine Development and Commercialization

Adam C. Krol, Muna Abu-Shaar, and Paul Brady

1 Introduction

A patent provides the patent owner with the right to exclude others from making, using, or selling the patented invention [1]. Vaccine development presents many patenting opportunities and challenges. The costs of researching and developing a new vaccine before it can be authorized for marketing are huge. Estimates for the cost of getting a medicine from the bench to the marketplace range from \$1.5 billion to in excess of \$1.8 billion [2, 3]. Although the cost of manufacturing a vaccine may be small, the profit margin on the sales price needs to be high in order to enable the massive cost of research and development to be recouped. Patents and other intellectual property rights are key to establishing market exclusivity and thus maintaining the necessary profit margin.

To illustrate how patents can be used to protect inventions made throughout the vaccine development process and to provide an introduction to issues that might be encountered in the patenting process, this chapter follows a hypothetical vaccine development timeline (summarized in [Appendix](#)) for a newly discovered infectious virus from a United States (US) patent law perspective. The hypothetical timeline may appear oversimplified, and the time between events may not accurately reflect the speed of real-world vaccine development. However, the purpose of the timeline is to introduce several important patent law concepts that the reader may encounter in the real world. Key differences between the US and two other major patent jurisdictions, Europe and Japan, are noted where applicable.

2 Discovery of New Virus and Processes for Its Propagation, Inactivation, and Attenuation

The timeline begins on January 1, 2016 with the discovery of the previously unknown Zoobug virus by scientists at Vacsotech Inc. In the 3 months following the discovery and isolation of Zoobug, the scientists at Vacsotech discover how to inactivate the virus using heat and radiation and discover how to propagate the virus in a human mesenchymal cell line, Zalex89. The scientists generate an attenuated strain of Zoobug (strain S1) by propagating Zoobug in mouse epithelial cell line MOG732. Vacsotech deposits the Zoobug-infected Zalex89 cell line with the American Type Culture Collection under the provisions of the Budapest Treaty on the International Recognition of the Deposit of Microorganisms for the Purposes of Patent Procedure (known as the “Budapest Treaty” for short).

Following its discoveries and the deposit, Vacsotech files a patent application (Patent Application No. 1) in the US Patent and Trademark Office (USPTO) and the European Patent Office (EPO). The EPO grants European patents for nation states that are parties to the European Patent Convention [4]. Following the grant, a European patent may be validated in individual member states if patent protection is desired in those states.

Patent Application No. 1 is filed with illustrative claims 1–7 as set out in [Appendix](#). A patent claim is a single-sentence, numbered paragraph located at the end of the patent following a written description of the invention [5]. The claims define the boundaries of the patent owner’s right to exclude, in the same way that a fence can be used to define the boundaries of a plot of land. Patents typically include claims of varying scope, from broad to narrow [6]. A real patent application would likely be filed with a greater number of claims and with claims of a more varied scope than the patent applications in the hypothetical timeline.

The USPTO and EPO will each examine Patent Application No. 1 and will issue a patent if the claims are found to satisfy all requirements for patentability. This patent filing raises two requirements for patentability, as discussed below. The other requirements for patentability are discussed in Sections 3 and 4 in the context of Patent Application Nos. 2 and 3.

2.1 Patentable Subject Matter

Claim 1 of Patent Application No. 1 is directed to “isolated Zoobug.” US patent law provides that “any new and useful process, machine, manufacture, or composition of matter, or any new and useful improvement thereof,” may be patented if certain conditions of patentability are met [7]. Zoobug is a “composition of matter” and would therefore appear to be patentable, or patent eligible in US parlance, subject matter. However, there are a number of judicially created exceptions to patent eligibility. One of the

exceptions relevant here is the exception relating to natural products. Naturally occurring products are considered to be patent ineligible, as are some man-made products if they are essentially no different from a naturally occurring product [8].

The test currently applied by the USPTO to determine subject matter eligibility asks whether a nature-based product recited in a claim has “markedly different characteristics” from its naturally occurring counterpart in its natural state [8]. If the nature-based product has markedly different characteristics, the claim is patent eligible. Thus, claim 1 of Patent Application No. 1 is likely found to be patent ineligible unless it can be shown that isolated Zoobug has markedly different characteristics from naturally occurring Zoobug. The USPTO has published a series of examples illustrating how the USPTO analyzes claims reciting a nature-based product for subject matter eligibility and readers seeking a deeper understanding of the subject matter eligibility analysis are encouraged to review them [9].

Claim 3, directed to an “attenuated Zoobug strain,” and claim 4, directed to a specific attenuated strain of Zoobug, are likely to be found patent eligible because the attenuated virus should be found to have markedly different characteristics from naturally occurring Zoobug, e.g., it is noninfectious and may have different DNA/RNA or protein structures.

Claim 2, directed to “inactivated Zoobug,” falls into a zone of uncertainty created by the recent Supreme Court case law regarding the patentability of inventions based on natural products and natural phenomena. For example, in one of its decisions, the Supreme Court held that genomic DNA extracted from cells is not patent eligible, whereas cDNA is patent eligible only if the underlying mRNA has been subject to RNA splicing to remove introns—otherwise it is too similar to the naturally occurring genomic DNA [10]. The limits of the judicial exceptions to subject matter eligibility have yet to be determined. The patent eligibility of inactivated Zoobug might depend on whether inactivation encompasses simply killing the virus or altering its structure or biological properties.

The patent eligibility of claims 5–7 is also uncertain, if a recent decision [11] by the US Court of Appeals for the Federal Circuit (the court below the Supreme Court that handles patent matters) stands. In that decision, the Federal Circuit held that claims to methods for detecting cell-free fetal DNA (cffDNA) in maternal serum or plasma by amplifying and detecting the cffDNA are patent ineligible. The inventors were the first to discover cffDNA in maternal serum and plasma, but methods for amplifying and detecting DNA were known at the time the invention was made. Finding the claimed methods to be patent ineligible, the Federal Circuit stated that “[w]here claims of a method patent are directed to an application that starts and ends with a naturally occurring

phenomenon [e.g., cffDNA], the patent fails to disclose patent eligible subject matter if the methods themselves are conventional, routine and well understood applications in the art” [12]. Thus, claim 5 of Patent Application No. 1 is likely to be rejected as patent ineligible if the use of Zalex89 cells for virus propagation was routine in view of the fact that Zoobug is a naturally occurring virus. Claims 6 and 7 likely have a greater chance of being found patent eligible than claim 5 because the methods of claims 6 and 7 produce an attenuated virus that has markedly different characteristics from the naturally occurring Zoobug.

In Europe and most other jurisdictions, the separate requirement for an invention to be “patent eligible” does not arise. In the case of a naturally occurring compound (or organism or virus), the wording of a patent claim needs to be such that the claim does not cover the compound in the form in which it exists in nature. Specifying that the compound is isolated, or that it is in a pharmaceutical formulation, is generally sufficient to provide the necessary novelty.

On the other hand, many jurisdictions have a bar on granting patent claims to methods of medical treatment, and it is thus not possible to claim “a method of vaccinating a subject against disease X by administering vaccine Y.” The philosophy behind this is that doctors should be free to treat patients how they best see fit without having to be concerned about patent infringement at the bedside. However, uses of vaccines can usually be protected by claiming the uses in particular formats, as described in more detail in Section 3.3 below.

2.2 Written Description and Enablement

The rationale of the patent system is to promote innovation by granting to inventors limited monopolies in exchange for disclosure of their inventions to the world [13]. The disclosure is made via a patent specification preceding the claims [14]. The patent specification must provide a description (the written description requirement) that enables (the enablement requirement) the claimed invention in order for a patent to issue [15]. The written description requirement ensures that the inventor “possessed” (i.e., actually invented) the subject matter of the claims rather than merely set forth a research plan for obtaining the claimed invention [16], while the enablement requirement ensures that a person skilled in the relevant art can make and use the claimed invention without undue experimentation [17]. This is a necessary part of the “bargain” between the state and the inventor: if the inventor does not disclose his invention in a way that enables a skilled practitioner to put it into practice after patent expiry, then he does not deserve the monopoly period that the patent provides. The courts have found the “use” prong of the enablement requirement to include evidence that the invention actually works as claimed; for example, in the case of a claim to a vaccine formulation evidence that the formulation elicits an immune response when administered to a subject might be needed to meet the enablement requirement.

Inventions such as a new virus and methods for its propagation, inactivation, and attenuation may be impossible to describe and enable merely by words in the specification unless the entire genome is sequenced and it is possible to reconstruct the virus based on a synthetic copy of its genome. The solution for such inventions is the deposit of a replicable copy of the virus, for example in a cell line, with an international depositary so that the virus is made available to those who are interested in practicing the invention. Such deposits were made possible by the Budapest Treaty, which permits “deposits of microorganisms [and cell lines] at an international depositary authority to be recognized for the purposes of patent procedure” [18]. For the purpose of this hypothesis, both Zalex89 and MOG732 are commercially available from a vendor and therefore do not pose any enablement/written description issues. As long as conditions of the Budapest Treaty are met, Vaccotech’s deposit of Zalex89 infected with Zoobug satisfies the enablement and written description requirements for claims 1, 2, 5, and 7 [19].

What about claims 3, 4, and 6?

Claim 3, directed to attenuated Zoobug, is likely to be rejected for lack of written description. Assuming there are a myriad of mutations that result in attenuation, and Patent Application No. 1 does not describe any specific mutations, the US examiner would likely take the position that the inventors had not demonstrated they had invented a sufficient number of attenuated strains representative of the entire class of attenuated Zoobug strains. This requirement is distinct from the enablement requirement [20]; therefore, even if the application describes *how* attenuated strains can be made and thus meets the enablement requirement, it does not describe the attenuated strains themselves, thus likely falling short of the written description requirement.

Claim 4, directed to attenuated Zoobug strain S1, is likely to be rejected for lack of written description and enablement, as the inventors did not describe in their application the sequence alterations that result in strain S1 being attenuated as compared to the Zoobug parent strain. Assuming that attenuation can be achieved by any number of mutations to the Zoobug genome, there is no way to exactly reproduce strain S1. In the US, a Budapest Treaty deposit can be made *after* the filing to address the rejection [21, 22], but in Europe [23] (and other jurisdictions) it is too late to make the deposit once the application has been filed.

Claim 6, directed to a process for attenuating Zoobug using *any* animal cell line, is likely to be rejected for lack of enablement. The inventors showed that Zoobug can be attenuated in mouse epithelial cell line MOG732 but have not shown that attenuation can be achieved in all cell lines—after all, Zoobug can be propagated without attenuation in human mesenchymal cell Zalex89, which is also an animal cell line. A patent examiner will want to know why propagation in Zalex89 and MOG732 results in

different outcomes. Is it the species of the cell line, the type of tissue, the propagation conditions, or a combination of all factors? Unless the inventors can provide a rationale and evidence that Zoobug can be attenuated in any animal cell line under appropriate conditions that do not require “undue” experimentation, claim 6 is unlikely to be allowed.

In most jurisdictions around the world there is a requirement for the patent specification to “sufficiently enable” the invention in the same way as in the US [24]. Most jurisdictions outside the US do not have a separate “written description” requirement. However, as it is necessary in all jurisdictions to present evidence that it is plausible that an invention does work and is thus inventive, the same contents as needed to satisfy the US written description requirement are generally needed.

3 Identification and Recombinant Expression of Zoobug Antigens and Preclinical Vaccine Development

After the initial discoveries, scientists at Vacsotech sequence the genome of Zoobug and begin developing formulations for potential clinical vaccines. They conduct preclinical testing, in primates, of five different immunogens, each formulated in combination with either adjuvant X or adjuvant Y: (1) heat-inactivated Zoobug; (2) attenuated Zoobug strain S1; (3) a recombinantly expressed viral envelope protein, ENV1; (4) a recombinantly expressed polymerase protein, POL; and (5) peptides from ENV1 and POL that computer software identified as being likely immunogenic epitopes. Only Vaccine A, a formulation containing attenuated Zoobug strain S1 and adjuvant Y, shows promise as a vaccine and is selected for clinical trials after a successful challenge study in primates.

Vacsotech files its second patent application, Patent Application No. 2, with the intention of claiming inventions relating to ENV1, POL, and the vaccine formulations. Patent Application No. 2 is filed with claims 1–4, directed to ENV1 and POL proteins (claim 1), a variety of immunogenic compositions (claim 2), an immunogenic composition containing attenuated Zoobug strain S1 (claim 3), and the use of the immunogenic compositions to immunize against Zoobug (claim 4). Seven months prior to filing Patent Application No. 2, Patent Application No. 1 was published by both the USPTO and the EPO. Three months prior to filing Patent Application No. 2, Vacsotech scientists presented their research at a conference, and a conference book containing excerpts of the poster data was handed out at the conference. The presentation included a poster with the sequences of ENV1 and POL. The publication of Patent Application No. 1 and the presentation at the conference raise issues regarding two additional requirements for patentability, as discussed below.

3.1 Novelty

A claimed invention must be novel, i.e., new, to be patentable [25]. US patent law provides limited exceptions in which certain disclosures occurring before the effective filing date of the claimed invention will not be considered prior art to the claimed invention [26]. For example, a disclosure made by the inventor 1 year or less before the effective filing date will not be considered prior art in assessing the novelty of the claimed invention [27]. For the sake of simplicity, this hypothetical assumes that all Vacsotech inventions are made by the same inventor. Japanese patent law provides a 6-month grace period for inventor disclosures [28]. This 6-month grace period is referred to as the “exception under Art 30” or the “exception for novelty depletion” and has to be requested by the applicant. However, many jurisdictions have an absolute novelty requirement, which means that any disclosure (including by the inventors themselves) of the claimed invention prior to the claimed invention’s filing date will preclude a patent on the invention [29]. Even in situations in which only a US patent is desired, for example, inventors should consider filing before publicly disclosing their inventions to avoid the risk that a disclosure might fall outside of one of the limited exceptions.

Here, neither the publication of Patent Application No. 1 nor Vacsotech’s conference presentation can be used as prior art by the US patent examiner to reject any claim of Patent Application No. 2 because both are inventor disclosures occurring 1 year or less before the filing date of Patent Application No. 2. If no prior art relating to Zoobug exists, each of claims 1–4 should be found to be novel under US law.

The publication of Patent Application No. 1, and the ATCC deposit referred to therein, will be prior art to the claims of Patent Application No. 2 in Japan because the publication of Patent Application No. 1 falls outside of the 6-month grace period provided by Japanese Law. The conference presentation, on the other hand, will not be considered prior art to the claims of Patent Application No. 2 in Japan because the presentation falls within the 6-month grace period. Therefore, assuming that Patent Application No. 1 does not describe the subject matter of claims 1–4, the Japanese patent examiner should find the claims novel.

In contrast to the US and Japan, European patent law has an absolute novelty requirement, without a grace period for inventor disclosures [29]. Therefore, both Patent Application No. 1 and the conference presentation will be considered as prior art by the EPO examiner. Because the conference materials describe the sequences of ENVI and POL, claim 1 is likely to be found not patentable for lack of novelty over the conference presentation. Because the subject matter of claims 2–4 are not disclosed in Patent Application No. 1 or the conference materials, the claims are likely to be deemed novel.

3.2 Nonobviousness (Inventive Step)

A claimed invention must also be nonobvious in view of the prior art [30]. A claimed invention is not patentable when it would have been obvious before its effective filing date to a person having ordinary skill in the art to which the claimed invention pertains, for example, if the invention is a routine or predictable variation of the prior art [30]. One way for a US patent examiner to reject a claimed invention on the basis of obviousness is to show that a person of ordinary skill in the art would have had a motivation to modify the prior art in a manner that results in the invention as claimed and had a reasonable expectation that the modification would be successful. The person having ordinary skill in the art is a hypothetical person presumed to have known the relevant art at the time of the invention [31]. Because obviousness is analyzed using a hypothetical person having ordinary skill in the art, it does not matter that the claimed invention may have appeared straightforward to the inventor(s), who are oftentimes individuals of extraordinary skill in their field. Moreover, US patent law provides that “patentability shall not be negated by the manner in which the invention was made,” which means that it does not matter whether the claimed invention resulted from long, painstaking effort or serendipity [30]. The concept of nonobviousness is referred to as “inventive step” in many countries outside of the US [32].

If no third-party prior art relating to Zoobug exists, claims 1–4 of Patent Application No. 2 should be found nonobvious by the US patent examiner because, as discussed above, neither the publication of Patent Application No. 1 nor the conference presentation will be considered prior art.

Because the publication of Patent Application No. 1 and the ATCC deposit referred to therein are considered prior art in Japan, and assuming no other Zoobug-related prior art exists in Japan, the patent examiner will inquire, with respect to claim 1, whether it would have been obvious and routine to identify and express individual proteins from viruses of the same class as Zoobug from a cell infected with the virus (in view of Patent Application No. 1 and the deposited cell line as prior art) [33]. Likewise, the patent examiner will inquire, with respect to claims 2–4, whether those of skill in the art would be motivated to combine attenuated or inactivated forms of Zoobug with adjuvants for use as a vaccine, with reference to Patent Application No. 1 and the deposited cell line as prior art. If the answer to those questions is yes, then the claims will likely be deemed to be obvious.

As discussed above, the prior art base under European patent law includes the inventor disclosures, and thus the conference disclosure will be taken into account when inventive step is analyzed at the EPO. As discussed above, claim 1 will likely be rejected for lack of novelty over the conference disclosure. Claims 2–4 should be held novel, and they will then be examined for inventive step [32]. The examiner will seek to establish whether, starting

from the sequences of ENV1 and POL disclosed on the conference poster, a person skilled in the art would have been motivated to combine attenuated or inactivated forms of Zoobug with adjuvants for use as a vaccine with an expectation of success. If the answer to that is yes, then claims 2–4 will be rejected by the examiner on the grounds of lack of inventive step.

3.3 Patentable Subject Matter

Claim 1 of Patent Application No. 2 is directed to “isolated ENV1 or isolated POL.” Claim 1 is likely to be rejected by the USPTO as being directed to patent ineligible subject matter unless it can be shown that the isolated proteins are “markedly different” from ENV1 and POL in their natural state, in the same way the cDNA, but not genomic DNA, was found to be patent eligible by the Supreme Court [10].

Claim 4 is not patentable subject matter in most jurisdictions, including Europe [34] and Japan [35], where there is a prohibition on patenting methods of medical treatment of the human body. Such method claims can be rewritten as purpose-limited composition claims (acceptable in Europe and Japan) or as so-called Swiss-type claims (acceptable in Japan during patent prosecution, although the scope of such claims is uncertain in an enforcement action). For example, Claim 4 can be rewritten as a purpose-limited composition claim that recites “the immunogenic composition of claim 2 or claim 3 for use in immunizing a human against Zoobug infection” or as a Swiss-type claim that recites “use of the immunogenic composition of claim 2 or claim 3 in the manufacture of a vaccine for protection against Zoobug infection in humans.” Using these forms of claim language, essentially the same subject matter can be covered outside the United States in most situations.

3.4 Written Description and Enablement

Claims 2 and 4 of Patent Application No. 2, directed to immunogenic compositions of Zoobug and their use for vaccination, are likely to be rejected by the USPTO for a lack of adequate written description. Claims 2 and 4 are generic in that they encompass formulations with *any* peptide epitopes of ENV1 and POL, instead of specifically defined epitopes, and adjuvant. The written description requirement for a claimed genus can be satisfied through the disclosure of either a representative number of species falling within the scope of the genus or structural features common to the members of the genus so that one of skill in the art can visualize or recognize the members of the claimed genus [20]. The ten candidate vaccines created at Vacsotech each contained one immunogen and either adjuvant X or adjuvant Y, and only one of those vaccines, Vaccine A, was found to be immunogenic. Thus, a US patent examiner is likely to find that the disclosure of a single immunogenic composition is insufficient to show the inventors’ possession of the full scope of the inventions recited in claims 2 and 4.

Claims 2 and 4 are also likely to be rejected by a US patent examiner as not enabled because most of the compositions actually made by Vacsotech and described in Patent Application No. 2 are not immunogenic and the inventors do not know what gives rise to immunogenicity, i.e., the inventors do not know why Vaccine A is immunogenic but the other candidate vaccines are not. Because the evidence shows that routine methods cannot be used to identify immunogenic compositions containing Zoobug epitopes and an adjuvant, the US patent examiner will likely conclude that it would require undue experimentation to identify immunogenic compositions within the scope of claim 2 and which can immunize a subject against Zoobug as required by claim 4.

Similarly, the need for undue experimentation to be able to put the invention into practice may lead a patent examiner to conclude that the claims are not sufficiently enabled in jurisdictions outside of the US. In addition, if significant numbers of formulations within the scope of the claims are not immunogenic, then a patent examiner can reject the claims for lack of inventive step. European patent examiners typically reject such claims for lack of an inventive step, while Japanese patent examiners typically reject such claims for lack of enablement.

4 Further Preclinical and Clinical Vaccine Development

Clinical trials with Vaccine A are aborted when it is discovered that the vaccine triggers autoimmune symptoms in study subjects. Scientists at Vacsotech research an alternative vaccine and generate a variety of fusion proteins containing portions of ENVI and POL. Preclinical trials show that Vaccine B, a formulation containing a fusion protein (referred to as PE) containing epitope E of ENVI and epitope P of POL together with adjuvants X and Y, elicits a protective immune response in primates. Clinical trials (the existence and dosing schedules of which are published on clinicaltrials.gov without giving details of the identity of the fusion protein or the adjuvants) establish that the fusion protein is not effective when administered in a single dose but is safe and more effective than attenuated Zoobug strain S1 when administered in two intramuscular doses separated by 3 months.

Vacsotech files Patent Application No. 3 directed to the fusion protein, the formulation containing adjuvants X and Y, and the two-dose administration schedule. The claims of Patent Application No. 3 raise issues of novelty, obviousness/inventive step, written description, enablement, and patentable subject matter.

4.1 Novelty

The publication of the existence of the clinical trials on clinicaltrials.gov should not be considered as prior art by the US patent examiner when examining the novelty of the claims because the disclosure is an inventor disclosure occurring 1 year or less before

the filing of Patent Application No. 3. The publication should also not be considered as prior art by the Japanese examiner because it is an inventor disclosure occurring within 6 months or less before the filing of Patent Application No. 3.

In contrast, the disclosure will be considered prior art to the claims of the European application because Europe does not have a grace period for inventor disclosures. The *clinicaltrials.gov* publication does *not* disclose the identity of the fusion protein or the adjuvants, so claims reciting those features (e.g., claim 2 and claims 4, 6, 8, and 10 that depend from claim 2) should be considered novel by the European patent examiners. If the *clinicaltrials.gov* publication discloses that the trial is with a fusion protein of two epitopes of Zoobug, then the generally worded claim 1 will lack novelty under European law, and some of the claims that depend from claim 1 will also lack novelty, depending on how detailed the *clinicaltrials.gov* publication is.

4.2 Obviousness (Inventive Step)

Because the *clinicaltrials.gov* publication is not considered prior art in the US and Japan, it cannot be used as a basis for an obviousness rejection.

The publication *is* considered prior art under European patent law and can be used in an inventive step rejection. Claim 2, directed to a fusion protein containing the epitopes present in Vaccine B, is likely to be found inventive given the prior failures in achieving a safe and effective Zoobug vaccine—one of skill in the art could not predict which epitopes would be effective immunogens. All claims that depend from claim 2 (and therefore incorporate by reference the particular fusion protein), including claim 10, are also likely to be found inventive for the same reasons. Claim 9, reciting the particular adjuvants, but without limitation to the specific fusion protein, is at risk of lacking inventive step if adjuvants X and Y were known in the art. The rejection might be overcome by showing that the combination of adjuvants X and Y conferred unexpected properties, such as synergistically increasing the immune response to a degree not predictable from the prior art.

4.3 Written Description and Enablement

Method claims 3, 5, 7, and 9 of Patent Application No. 3 are likely to be rejected by a US patent examiner for failing to comply with the written description requirement. These claims depend directly or indirectly from claim 1, which recites a “fusion polypeptide comprising at least two epitopes of Zoobug.” The term “comprising” in most jurisdictions is open ended and permits other ingredients to be included in the composition. Thus, the methods of claims 3, 5, 7, and 9 are not limited to epitopes E and P but encompass fusion proteins containing any two epitopes of Zoobug. However, Patent Application No. 3 only describes a single immunogenic composition, Vaccine B, which contains a fusion polypeptide of epitope E and epitope P together with specific adjuvants X and Y. Consequently, a US patent examiner is likely to

conclude that the description of a single species (Vaccine B) is insufficient to entitle the inventors to claims which are not limited to a fusion protein comprising epitopes E and P.

Moreover, claims 3, 5, 7, and 9 would also likely be rejected by a US patent examiner for failing to comply with the enablement requirement because a US patent examiner would likely question whether undue experimentation would be required to identify fusion proteins, adjuvants, and dosing schedules to practice claims 3, 5, 7, and 9. If it cannot be shown that substantially all fusion proteins are effective, the same claims may encounter a similar objection in other jurisdictions.

4.4 Patentable Subject Matter

Method claims 3–10 are not patentable subject matter in Europe or Japan and will elicit a rejection with a request to rewrite the claims in one of the acceptable formats described in Section 3.3. For example, the method claims can be recast in the form “the fusion protein of claim 1 for use in inducing an immune response in a subject.”

4.5 Further Considerations for Patent Specifications in the Vaccine Field

In general, vaccine products can be more complex than standard pharmaceuticals: vaccines are often multivalent and so contain several active components, and they often contain adjuvants that can be critical to their effectiveness. Patent term extensions (described in Section 5.1 below) are in some jurisdictions only available if the approved product is disclosed in the patent, at least at a general level. If the product that is approved by the regulatory authorities is a multivalent vaccine, the disclosure of just one of the epitopes in the patent application is, in some jurisdictions, not considered to be an adequate disclosure for the patent to be eligible for extension. It is thus important to include in a patent application for an element of a vaccine a general description of the other components of the vaccine in which it is likely to be used. That description of the other components that might be included (e.g., adjuvants or other antigens) should be as specific as possible based on the current knowledge of the most likely approved product. Claims directed to the final vaccine with components defined in as specific terms as possible should also be included.

5 Regulatory Approval and Post-approval Developments

Anticipating regulatory approval of Vaccine B by the US Food and Drug Administration (“FDA”) and the European Medicines Agency (“EMA”), Vacsotech decides to amend the claims in order to obtain quick allowance and Patent Application No. 3 issues into a patent with claims 1–3 in the US, Europe, and Japan on March 1, 2022. The FDA and the EMA approve Vaccine B on June 1, 2023, and Vacsotech commercially launches Vaccine B in the US and the EU on August 1, 2023. Japan’s Ministry of Health, Labour

and Welfare (MHLW) approves Vaccine B in Japan on August 1, 2025, and Vacsotech commercially launches Vaccine B in Japan on January 1, 2026.

**5.1 Patent Term
Extension or
Supplementary
Protection Certificate**

Patents generally have a term that lasts 20 years from filing [36]. For patents covering a pharmaceutical product, a substantial portion of the patent's term may run before regulatory approval. Many jurisdictions have enacted laws that restore at least some of the patent terms lost to regulatory approval. In the US, the Drug Price Competition and Patent Term Restoration Act of 1984, commonly called the Hatch-Waxman Act, provides patent term extension (PTE) in certain circumstances to compensate patentees for patent term that is effectively “lost” between the period of patent issuance and regulatory approval [37]. The term of a patent in some European countries may likewise be extended by way of a Supplementary Protection Certificate (SPC) [38]. SPCs may be extended by 6 months if the patentee conducts a pediatric study [39]. In Japan, a PTE is available for the “period during which the patented invention was unable to be worked” due to the requirements that pharmaceutical products receive government approval before marketing [40].

Even though Vacsotech's patents from Patent Application No. 3 issue prior to regulatory approval of Vaccine B, Vacsotech is not eligible for a PTE in the US or an SPC in Europe. In the United States, the patent is not eligible for PTE because the patent term remaining after FDA approval exceeds 14 years [41]. Similarly, an SPC is not available because there is more than 15 years of patent term remaining following EMA approval [38]. In contrast, Vacsotech can extend the term of its Japanese patent for 2 years and 1 month, the period from Vacsotech's application for regulatory approval to approval, regardless of the patent term remaining after approval. The amount of extension in Japan is the period from (1) the letter of (a) submission of an IND and (b) patent registration to (2) regulatory approval.

If any claims of Patent Application Nos. 1 or 2 in the US or Europe have been granted with wording that covers the fusion protein in the approved product, it might be possible to obtain a PTE (in the US) or SPC (in Europe) if the remaining term following approval is less than 14 or 15 years, respectively. In all three jurisdictions, the maximum extension, when available, is 5 years [38, 42, 43].

**5.2 Commercialization
and Freedom
to Operate**

A patent does not give the patent owner any affirmative right to practice the invention claimed in the patent. The patent owner can be prevented from practicing the claimed invention if practice of the invention is subject to other laws, such as those regulating the marketing of vaccines, or if practice of the invention would infringe another's patent. For example, if adjuvant X is claimed in a non-expired

patent owned by a third party, Vacsotech cannot manufacture adjuvant X, include it in Vaccine B, and then sell Vaccine B without infringing the third party's patent on adjuvant X. Vacsotech will need to purchase adjuvant X from the third party or a licensee of the third party authorized to sell adjuvant X or will need to seek a license to the patent in order to avoid infringing the patent on adjuvant X.

35 U.S.C. § 271(e) provides a safe harbor that exempts otherwise infringing activities from claims of patent infringement when those activities are "reasonably related to the development and submission of information" to the FDA [44]. Although the determination of whether the safe harbor applies is fact specific, the use of patented inventions during vaccine development would likely be exempt from infringement liability in most cases [45]. However, because the safe harbor is generally unavailable for commercial production and sale, a freedom to operate study should be performed to identify third-party patents that could present an obstacle to commercialization. By identifying such patents early in the development process, the greatest number of options for avoiding infringement will be available, for example, by designing around a blocking patent or seeking a license.

As mentioned above, it is common for vaccine products to be complex mixtures of several antigens and adjuvants. Very often the different components will have been developed by different parties, and a significant licensing agreement will be needed in order for a product to be commercialized. It is generally in all parties' interests for a product to go ahead, and patent licensing should not be shied away from. The earlier in the development process the patent licensing for the product can be dealt with, the smoother will be the development of the product.

5.3 Generic Competition

5.3.1 Regulatory Exclusivity

Patents are not the only means for protecting vaccines against competition. In the US, vaccines are classified as "biological products" by Section 351 of the Public Health Service (PHS) Act [46]. Under the Biologics Price Competition and Innovation Act (BPCI) of 2009, new biological products are entitled to 12 years of market exclusivity, during which time the FDA may not approve a "biosimilar" for the same indication as the reference product [47]. A product can be considered a "biosimilar" if it is highly similar to a reference product and has no clinically meaningful differences relative to the reference product [48]. The BPCI amended the PHS to implement an accelerated approval process for biosimilars under new subsection 351(k) [49]. An additional 6 months of exclusivity is available if a biologics license applicant performs pediatric studies in response to a request for such studies by the FDA [50, 51].

In Europe, the regulatory exclusivity follows what is referred to as the "8+2+1" year approach [52]. During the first 8 years

from regulatory approval, a generic manufacturer cannot rely on the innovator's data for regulatory approval. In the following 2-year period, a generic manufacturer can submit an application for regulatory approval that relies on the innovator's data but still cannot market its generic product until 10 years from the innovator's regulatory approval, unless the innovator product qualifies for a further year of exclusivity, in which case the generic manufacturer cannot market its product until 11 years from the innovator's regulatory approval. This additional year may be obtained in a number of circumstances, such as obtaining regulatory approval for one or more new therapeutic indications that demonstrate significant clinical benefit over existing therapies [53].

In Japan, when a drug is approved, the MHLW determines a so-called "reexamination period" [54]. The innovator is responsible for collecting post-marketing data during the period and reporting the data to the regulatory authority after the period expires [55]. Until the reexamination period expires, a generic manufacturer cannot rely upon the innovator's data when applying for marketing approval for a generic version of the drug [56]. Therefore, the reexamination period is equivalent to regulatory exclusivity period in the US. The length of reexamination period is typically 8 years for a drug containing a new active ingredient [57].

5.3.2 Differences between Regulatory Exclusivity and Patents

The scope of protection provided by the regulatory exclusivity laws governing vaccines can be significantly different from the scope of protection provided by patents.

First, regulatory exclusivity only protects an innovator's biologic product (called a "reference product") against competition from a biosimilar or generic manufacturer. A competitor motivated to compete with an innovator may seek approval based upon its own clinical trials instead of seeking approval as a biosimilar. In principle, the competitor could thus carry out its own trial. As well as the high costs of clinical trials, there are many circumstances in which it is unethical to carry out a trial on a treatment that is already known to be effective, and regulators might refuse permission for the trial to be carried out. But, if the competitor is developing a product that may be in some way a clinical advance, then the competitor may be able to generate its own clinical data and thus circumvent the regulatory data exclusivity that the original product developer has. In contrast, a patent may have a much greater exclusionary effect depending on the scope of its claims: the manufacture, use, sale, offer for sale, or importation of any product falling within the scope of the claims constitutes patent infringement, regardless of how the product came to be developed.

Second, regulatory exclusivity begins upon regulatory approval, whereas patent protection begins upon patent issuance [1, 47]. Thus, the term of patent protection may be longer or

shorter than the regulatory exclusivity depending upon the time lapse between the date of patent filing and date of regulatory approval. Consequently, the protection provided by regulatory exclusivity and the protection provided by a given patent will likely cover different periods of time. The date on which the last of them expires is often referred to as the “loss of exclusivity” date.

6 Lifecycle Management Considerations

As noted above, patents can cover processes, machines, manufactures, and compositions of matter. A patent portfolio that covers multiple aspects of a vaccine, its production, and use can be employed to maximize patent protection and limit the ability of competitors to compete in the same market. For example, the initial patent filing in a vaccine patent portfolio might be directed to a genus of active agents, such as a genus of mutant proteins, identified by initial testing to be potentially useful in a vaccine. If subsequent experimentation identifies a particularly useful species of the genus not disclosed in the initial patent filing, a second patent filing specifically claiming that species can provide protection for the species that extends beyond the term of a patent issuing from the initial filing. As preclinical development of the vaccine continues, specific vaccine formulations, adjuvants, production processes, screening assays, or apparatuses suitable for production of a vaccine component may be developed that warrant additional patent filings. Clinical trials can result in discoveries warranting further patent filings. For example, a vaccine may prove to be particularly effective in a particular patient population or when administered according to a particular protocol. Even further patent filings may be warranted after initial FDA approval if new production processes are developed during production scale-up or if improved formulations or combination vaccines are developed. In summary, filing on inventions made throughout a vaccine’s lifecycle can extend the length of patent protection by providing patents that expire later than any patent issuing from the initial filing.

6.1 Costs

In the case of many early stage medicine development companies, the company’s patents can be its most valuable assets. It is thus important that the patents are obtained where they are available. On the other hand, there are significant costs associated with filing patent applications and progressing them to grant. Costs are an important consideration for any organization, no matter how large or small, and long-term budgetary planning is important for a patenting program.

Of course, the exact costs will vary from case to case depending on a patent's complexity and the number of jurisdictions it is filed in. If patent protection is required around the world, an international application under the Patent Cooperation Treaty (PCT) can be filed that defers national patent filings (the "national phase") to 30 months after the first patent filing date. As of June 2015, the PCT has 148 member states [58], which includes most Western countries but excludes some key jurisdictions such as Taiwan, Argentina, and Saudi Arabia. Filing a PCT application preserves the right to pursue national protection in all member states. The national phase is the usually single largest cost point in the patenting process. The choice of 30 months as the national phase entry deadline has been arrived at as a compromise between providing certainty to third parties about whether there will be a patent in a particular territory and allowing a patent applicant a reasonable amount of time to assess whether the invention will be sufficiently commercially successful to justify the national phase costs. In medical research, 30 months can pass very quickly. Particularly for a small company, it is important to try to align this deadline with milestones in the development program.

6.2 Challenges to Validity

It is a surprise to some observers that grant of a patent by a patent office does not constitute a guarantee of validity. Patent office examiners can work only on the basis of the documents and evidence that they have before them; their searches are limited to written literature, and they do not have facilities to repeat experiments. Examiners are often unable to find out if an invention was disclosed nonconfidentially at a conference or if it does not actually work. Patent applicants have an obligation to inform the USPTO of all documents that they are aware of that are material to the patentability of the invention, but that still does not guarantee that an examiner has all possible information at his or her disposal. Therefore, although patent office examiners do a good job, and there is a presumption of validity for US patents, a patent that has been granted cannot definitively be assumed to be valid. A granted patent remains open to challenge after grant, either at a national patent office or before national courts.

Acknowledgements

The authors also thank Mami Hino, J.D., a partner at the law firm of Abe, Ikubo, and Katayama in Tokyo, Japan, for her input on Japanese patent law. The authors also thank Scott McLean, J.D., for his assistance in researching and drafting this chapter.

Appendix

Date	Event	Exemplary patent claims
January 1, 2016	<p>Scientists at Vacsotech isolate Zoobug virus from the blood of a human showing symptoms of a viral infection and determine that Zoobug was previously unknown.</p> <p>The scientists shortly thereafter discover that Zoobug can be inactivated with radiation and heat and discover how to propagate Zoobug in human mesenchymal cell line Zalex89.</p> <p>Human cell line Zalex89 infected with Zoobug is subsequently deposited with American Type Culture Collection (ATCC) under the provisions of the Budapest Treaty.</p>	
March 1, 2016	<p>Scientists at Vacsotech discover how to attenuate Zoobug by propagating Zoobug in mouse epithelial cell line MOG732.</p>	
April 1, 2016	<p>Vacsotech files Patent Application No. 1 directed to Zoobug and attenuated strains of Zoobug. The application is filed in the US Patent and Trademark Office (USPTO) and the European Patent Office (EPO).</p> <p>The patent application describes Zoobug, how to propagate Zoobug in cell line Zalex89 and how to attenuate Zoobug in mouse cell line MOG732, and attenuated Zoobug strain S1. The patent application also refers to the ATCC deposit.</p>	<ol style="list-style-type: none"> 1. Isolated Zoobug. 2. Inactivated Zoobug. 3. An attenuated Zoobug strain. 4. The attenuated Zoobug strain of claim 3 which is Zoobug strain S1. 5. A process for propagating Zoobug, comprising inoculating Zalex89 cells with Zoobug, and culturing the inoculated cells in an aqueous culture medium. 6. A process for attenuating Zoobug, comprising inoculating an animal cell line with Zoobug, and culturing the inoculated cells in an aqueous culture medium. 7. The process of claim 6, wherein the animal cell line is mouse cell line MOG732.
October 1, 2017	<p>Patent Application No. 1 is published by the USPTO and the EPO.</p>	
February 1, 2018	<p>Scientists at Vacsotech present a poster at a conference that describes the amino acid sequences of two Zoobug proteins, ENV1 and POL, which they have identified and recombinantly expressed.</p> <p>Excerpts from the presentation are published in a book distributed at the conference.</p>	

(continued)

Date	Event	Exemplary patent claims
May 1, 2018	<p>Scientists at Vacsotech have sequenced the genomes of both Zoobug and attenuated strain S1, identifying the mutations that give rise to the attenuated phenotype.</p> <p>They have created ten candidate vaccines for preclinical trials containing the following immunogens in each of adjuvants X and Y:</p> <ul style="list-style-type: none"> – heat-inactivated Zoobug – attenuated Zoobug strain S1 – ENV1 – POL – peptide epitopes of ENV1 and POL <p>Only Vaccine A, the formulation containing attenuated Zoobug strain S1 and adjuvant Y, shows promise as a vaccine and is selected for clinical trials after a successful challenge study in primates. The remaining candidate vaccines are not immunogenic.</p> <p>Vacsotech files Patent Application No. 2 directed to ENV1, POL, and the candidate vaccines. The application includes the sequences of the genomes of Zoobug and S1.</p> <p>By now Vacsotech is better funded, and the application is filed in the US, Europe, and Japan.</p>	<ol style="list-style-type: none"> 1. Isolated ENV1 or isolated POL. 2. An immunogenic composition comprising: <ol style="list-style-type: none"> (a) (i) an attenuated strain of Zoobug (ii) an inactivated strain of Zoobug (iii) ENV1 or a peptide epitope thereof; or (iv) POL or a peptide epitope thereof and (b) an adjuvant. 3. The immunogenic composition of claim 2, wherein the vaccine comprises attenuated Zoobug strain S1 and adjuvant Y. 4. A method of immunizing a subject against Zoobug, comprising administering an effective amount of the immunogenic composition of claim 2 or claim 3 to the subject.
September 1, 2019	<p>Clinical trials with Vaccine A are aborted when subjects begin experiencing autoimmune symptoms</p>	
March 1, 2020	<p>Scientists at Vacsotech generate a fusion protein (referred to as PE) comprising epitope E of ENV1 and epitope P of POL and discover in preclinical studies that Vaccine B, containing the fusion protein and adjuvants X and Y, is more immunogenic than either antigen alone.</p>	
June 1, 2020	<p>Vacsotech submits an investigational new drug (IND) application to the US Food and Drug Administration (FDA) for testing the efficacy of intramuscular administration Vaccine B, both as a single dose and two doses separated by 3 months.</p> <p>Vacsotech's clinical trial plans are published on clinicaltrials.gov. The clinicaltrials.gov web site mentions Vaccine B by its code name, VCS123, refers to VCS123 as a fusion protein containing two epitopes of Zoobug, and describes the dosing schedules being tested.</p>	

(continued)

(continued)

Date	Event	Exemplary patent claims
October 15, 2020	Clinical trials establish that the fusion protein is not effective when administered in a single dose but is safe and more effective than attenuated Zoobug strain S1 when administered in two intramuscular doses separated by 3 months	
November 1, 2020	Vacsotech files Patent Application No. 3 directed to the fusion protein and the two-dose administration schedule in the US, Europe, and Japan	<ol style="list-style-type: none"> 1. A fusion polypeptide comprising at least two epitopes of Zoobug. 2. The fusion polypeptide of claim 1, wherein the two epitopes are epitope E and epitope P. 3. A method of inducing an immune response in a subject, comprising administering the fusion protein of claim 1 to the subject. 4. A method of inducing an immune response in a subject, comprising administering the fusion protein of claim 2 to the subject. 5. A method of immunizing a human subject against Zoobug, comprising administering an effective amount of the fusion protein of claim 1 to the subject. 6. A method of immunizing a human subject against Zoobug, comprising administering an effective amount of the fusion protein of claim 2 to the subject. 7. The method of claim 5, wherein the fusion protein is administered intramuscularly in two doses 3 months apart. 8. The method of claim 6, wherein the fusion protein is administered intramuscularly in two doses 3 months apart. 9. The method of claim 5, wherein the fusion protein is administered in a formulation with adjuvants X and Y. 10. The method of claim 6, wherein the fusion protein is administered in a formulation with adjuvants X and Y.

(continued)

Date	Event	Exemplary patent claims
March 1, 2022	Patent Application No. 3 issues into a patent in the US and Europe	<p><i>US claims:</i></p> <ol style="list-style-type: none"> 1. A fusion polypeptide comprising epitope E and epitope P. 2. An immunogenic composition comprising the fusion polypeptide of claim 1 and adjuvants X and Y. 3. A method of immunizing a human subject against Zoobug, comprising intramuscularly administering two doses of the immunogenic composition of claim 2 to the human 3 months apart. <p><i>European and Japanese claims:</i></p> <ol style="list-style-type: none"> 1. A fusion polypeptide comprising epitope E and epitope P. 2. An immunogenic composition comprising the fusion polypeptide of claim 1 and adjuvants X and Y. 3. The immunogenic composition of claim 2 for use in immunizing a human against Zoobug infection.
June 1, 2023	The FDA and the European Medicines Agency (EMA) approve Vacsotech's Vaccine B, containing fusion protein PE for administration in two intramuscular doses separated by 3 months.	
August 1, 2023	Vacsotech commercially launches Vaccine B in the US and the EU and applies for regulatory approval in Japan.	
September 1, 2025	Japan's Ministry of Health, Labour and Welfare (MHLW) approves Vacsotech's Vaccine B, containing fusion protein PE for administration in two intramuscular doses separated by 3 months.	
January 1, 2026	Vacsotech commercially launches Vaccine B in Japan.	

References

1. 35 U.S.C. § 271(a)
2. Paul SM et al (2010) How to improve R&D productivity: the pharmaceutical industry's grand challenge. *Nat Rev Drug Discov* 9:203–214
3. Mestre-Ferrandiz J et al (2012) The R&D cost of a new medicine. Office of Health Economics, London
4. www.epo.org/about-us/organisation/member-states.html
5. 35 U.S.C. § 112(b)
6. 35 U.S.C. § 112(d)
7. 35 U.S.C. § 101
8. 2014 Interim Guidance on Patent Subject Matter Eligibility, 79 FR 74618, 74623 (Dec. 16, 2014)

9. www.uspto.gov/patents/law/exam/mdc_examples_nature-based_products.pdf
10. *Association for Molecular Pathology v. Myriad Genetics, Inc.*, 133 S. Ct. 2107, 2019 (2013)
11. *Ariosa Diagnostics, Inc. v. Sequenom, Inc.*, Appeal Nos. 2014-1139 and 2014-1144 (Fed. Cir. 2015)
12. *Ariosa Diagnostics, Inc. v. Sequenom, Inc.*, slip opinion at p. 13
13. U.S. Constitution, Article I, Section 8
14. 35 U.S.C. § 112
15. 35 U.S.C. § 112 (a)
16. *Capon v. Eshbar*, 418 F.3d 1349, 1357 (Fed. Cir. 2005)
17. *In re Wands*, 858 F.2d 731, 737 (Fed. Cir. 1988)
18. www.wipo.int/treaties/en/registration/budapest/summary_budapest.html
19. *Enzo Biochem, Inc. v. Genprobe Incorporated*, 296 F.3d 1316 (Fed. Cir. 2002)
20. *Ariad Pharmaceuticals, Inc. v. Eli Lilly and Co.*, 598 F.3d 1336 (Fed. Cir. 2010) (*en banc*)
21. 37 CFR § 1.804
22. 37 CFR § 1.809
23. Rule 31 of the implementing regulations of the European Patent Convention
24. European Patent Convention, Article 83
25. 35 U.S.C. § 102
26. 35 U.S.C. § 102(b)
27. 35 U.S.C. § 102(b)(1)(A)
28. Japanese Patent Act, Article 30
29. European Patent Convention, Article 54
30. 35 U.S.C. § 103
31. Manual of Patent Examining Procedure § 2141.03, Ninth Edition (March 2014)
32. European Patent Convention, Article 56
33. Japanese Patent Act, Article 29(2)
34. European Patent Convention, Article 53(c)
35. Japanese Patent Act, Article 29(1)
36. 35 U.S.C. § 154(a)(2)
37. 35 U.S.C. § 156
38. Regulation (EC) 469/2009
39. Regulation (EC) 1901/2006
40. Japanese Patent Act, Article 67(2)
41. 35 U.S.C. § 156(c)(3)
42. 35 U.S.C. § 156(g)(6)
43. Regulation (EC) 469/2009, Article 13(2)
44. 35 U.S.C. § 271(e)
45. *Merck KGaA v. Integra Lifesciences I, Ltd.*, 545 U.S. 193, 202 (2005)
46. 42 U.S.C. § 262(i)(1)
47. 42 U.S.C. § 262(k)(7)(A)
48. 42 U.S.C. § 262(i)
49. 42 U.S.C. § 262(k)
50. 42 U.S.C. § 262(m)(2)
51. 42 U.S.C. § 262(m)(3)
52. EU Data Exclusivity Directive, 2004/27/EC
53. Directive 2004/27/EC, Article 10(1)
54. Pharmaceutical Affairs Act of Japan, Article 14-4
55. Pharmaceutical Affairs Act of Japan, Article 14-4, paragraph 6
56. Notification No. 0331015 of the Pharmaceutical and Food Safety Bureau (Mar. 31, 2005)
57. Notification No. 0401001 of the Pharmaceutical and Food Safety Bureau (Apr. 1, 2007)
58. www.wipo.int/pct/en/pct_contracting_states.html

Intellectual Property in Vaccine Innovation: Impact of Recent Patent Developments

Elizabeth Siew-Kuan Ng

1 Introduction

In 2015, three significant events on vaccine and patent law were commemorated. On the scientific front, it marked the 35th year of the declaration of a world freed from smallpox and the simultaneous cessation of its worldwide vaccination program [1]. Few may recall this devastating epidemic disease that spreads through many countries for centuries. Even fewer will recollect that it was Edward Jenner's innovative contribution to immunization and the smallpox vaccine that made it possible to eradicate this dreaded disease. It is indisputably one of the greatest achievements of modern medicine. With respect to patent jurisprudence, two significant events are remembered: First, it coincidentally was also the 35th anniversary of the landmark decision of the United States (US) Supreme Court in *Diamond v Chakrabarty* (*Chakrabarty*) which held that human-made living matter was patent eligible subject matter. Not surprisingly, that decision galvanized a dynamic biotechnology industry into an era whereby "anything under the sun that is made by man" was regarded as being patentable. Second, it was only 2 years ago when another groundbreaking decision in *Association for Molecular Pathology v Myriad Genetics* (*Myriad*) [2] where the US Supreme Court, with an unusual unanimity, ruled that isolated genomic DNA, being "products of nature," are not patent eligible unlike man-made complementary DNA (cDNA). This approach dramatically scaled back the concept of patentable subject matter and overturned several decades of the US Patent and Trademark Office (USPTO) practice in the granting of gene patents. The decision represents a departure from the international practice at that time.

As we celebrate the 220th anniversary of Edward Jenner's outstanding contribution, it may be an opportune time to review the impact of intellectual property (IP) law on the development of vaccines. Although there are several aspects of IP rights that govern the protection of innovation in vaccines, this chapter will focus on the patent jurisprudence [3–5].

This chapter begins with a brief explanation of the role of patent law in biotechnology. It is then followed by an examination of the relevant US laws with respect to patent eligibility of microorganisms and human genes. The impact of these rules on vaccine innovation will be highlighted for further discussion. The analysis will address the patent eligibility of living organisms in three common categories that (a) exist naturally in nature, (b) have been isolated (i.e., merely extracted) from their natural environments in unmodified forms, and (c) have been modified/genetically engineered by man. The outcome of the analysis suggests that the patentability of those in categories 1 and 2 to the exclusion of category 3 will have a notable impact on the patent protection for vaccines derived from unmodified living or nonliving matter unlike those that utilize modified man-made complementary DNA (cDNA) and recombinant DNA (rDNA) [6, 7].

2 Role of Patent Law in Biotechnology [8]

Patents are “exclusive rights” granted by the State to enable the patent owner to exploit new, nonobvious, and useful inventions for a limited time, in exchange for sufficient disclosure of the invention [9–11]. It does not grant a right to practice the invention [12]. Rather, it permits the patent owner to prevent the commercial exploitation of the patented invention, take, for example, a patent on a vaccine. It does not confer on the patent owner the right to make the vaccine [13]; instead, it accords the right to stop commercial exploitation of the patented product.

The traditional role of the patent system to seek the promotion of scientific and technological advances for the betterment of mankind through the grant of patent exclusivity remains intact. The huge investment in research and development has led to calls for greater primacy to be accorded to the incentive/reward theory in order to support a more liberal interpretation on the patent eligibility of subject matter. The biotechnology and pharmaceutical industries have credited the incentive theory as the most significant factor in incentivizing innovation and investment in life sciences which has benefitted humanity [14]. They posit that patents are “the only things that matter” to compensate businesses for the huge investment in research and justify the high-risk burden [15].

No one denies that the patent owner deserves to be rewarded for the extensive investment and effort in research and

development. Yet, the grant of patent exclusivity may pose tremendous upstream and downstream challenges. It may impede information flow needed to spur future innovation by preventing other researchers from using the patented subject matter [16]. One commentator [17] has hinted that fears of impeding downstream innovation may have been the motivation behind the US Government's [18] recommendation to exclude isolated genomic DNA from patentability in the *Myriad* case. With the removal of the risk of costly patent infringement litigation on the use of isolated genomic DNA, the way has been paved for downstream innovation, such as that related to the "technology platform of whole genome sequencing" [17, 19].

Others have expressed fears that patent exclusivity allows the innovator to charge higher prices for the protected product which will block affordable access to much-needed medicines and vaccines, thereby impairing mankind's "right to health" [20]. They have highlighted the potential negative impact that overly extensive patent rights might have on the preservation of public health.

As we move toward a patent paradigm where the patent exclusivity seems to have assumed the "role of a legitimate reward for innovation, granted increasingly to multinational corporations" [21], it may perhaps be timely to examine the double-edged sword of patent protection in the context of vaccines.

3 Current Patent Landscape on Microorganisms and Genes

The domestic patent jurisprudence of almost every country is influenced by its international treaty obligations. One of the most important IP treaties is the Agreement on Trade-Related Aspects of Intellectual Property Rights (TRIPS Agreement) [22]. It is binding on the 161 member countries of the World Trade Organization (WTO). The TRIPS Agreement seeks to establish and harmonize certain minimum standards of IP protection with the objective that:

The protection and enforcement of intellectual property rights should contribute to the promotion of technological innovation and to the transfer and dissemination of technology, to the mutual advantage of producers and users of technological knowledge and in a manner conducive to social and economic welfare, and to a balance of rights and obligations. [23]

A brief discussion of relevant patent provisions in the TRIPS Agreement as they relate to microorganisms and genes is set out below.

3.1 TRIPS Patent-Related Provisions on Microorganisms/Genes

Article 27 of the TRIPS Agreement provides that patent protection must be provided for “any inventions, whether products or processes, in all fields of technology, provided that they are new, involve an inventive step and are capable of industrial application” [24]. Although it does not define what constitutes “an invention,” there is a list of subject matter which member states may be excluded from patentability under their domestic laws. These include “plants and animals *other than microorganisms*, and essentially biological processes for the production of plants or animals *other than non-biological and microbiological processes*” [25]. The TRIPS Agreement makes it clear that WTO countries may exclude from patent protection plants and animals, as well as essentially biological processes for their production. However, member states are obliged to provide patent protection for microorganisms, microbiological and non-biological processes. The TRIPS Agreement does not define what constitutes an “animal” or a “microorganism.” Neither is there any specific mention of gene patenting. As such, member states are expected to determine the most appropriate method of implementation [26, 27]. Although some degree of flexibility in multilateral agreements is generally desirable, the absence of a global consensus on many important patent issues, such as gene patenting, is an obvious trade-off.

A review of the patent jurisprudence in the USA may shed some light on this.

3.2 Are Microorganisms and Genes Eligible for Patent Protection in the USA?

Before proceeding, it may be useful to clarify three issues. First, it should be highlighted that issues relating to the patenting of living matter, such as microorganisms and human genes, lie at the intersection between patent law and ethics/morality. These have been adequately evaluated elsewhere and will not be debated here [28, 29]. Second, this work is not concerned with method claims, such as those relating to diagnostics which have been dealt with in the US Supreme Court decision of *Mayo Collaborative Services v Prometheus Laboratories* [16, 30]. Third, this discussion is focused on only one specific aspect of microorganism and gene patenting, namely, whether they are patent eligible subject matter in the USA. The patent eligibility issue is merely the first hurdle to *patentability*. If a microorganism or gene can satisfy this condition, a patent can be granted if it fulfills the other criteria of patentability, namely, new in the light of prior art (novelty), non-obviousness to a person who is skilled in the art (inventive step), and capable of industrial application (utility). Along with advances in scientific research, the pool of information and knowledge available in the prior art will increase, and this will make it more difficult to satisfy patentability criteria.

With this in mind, let us explore the patent landscape in the USA.

The issue of what constitutes patentable subject matter in the USA is governed by Section 101 of the US Patent Act 1952 (35 USC) which provides that:

Whoever invents or discovers any new and useful process, machine, manufacture, or composition of matter, or any new and useful improvement thereof, may obtain a patent therefore, subject to the conditions and requirements of this title.

Its statutory objective is grounded in the Constitution of the USA, i.e., “to promote the Progress of Science and useful Arts” [31]. Its exact scope is unclear and has been the subject of various judicial interpretations including two landmark decisions of the US Supreme Court. The first was in June 1980, where the Court affirmed in *Diamond v Chakrabarty* (*Chakrabarty*) that patents were available for “anything under the sun that is made by man” [32]. Then more than three decades later, this expansive approach was dramatically scaled back in *Association for Molecular Pathology v Myriad Genetics* (*Myriad*) where it was held that isolated genomic DNA, being “products of nature,” are not patent eligible unlike man-made complementary DNA (cDNA) which do not exist naturally.

A more detailed appraisal of these two decisions may serve to illuminate their impact on vaccine patenting.

3.2.1 *The Chakrabarty Case: Are Microorganisms Patent Eligible Subject Matter?*

Prior to 1980, the USPTO adopted a narrow approach to patent subject matter eligibility and excluded living things including man-made microorganisms from patentability. Then in 1980, the US Supreme Court affirmed in *Diamond v Chakrabarty* that the scope of patent eligible subject matter can encompass man-made living matters [32]. The fact that it involved living matter was not a relevant consideration on the issue of patent eligibility. The Supreme Court emphasized that the “relevant distinction was not between living and inanimate things but between products of nature, whether living or not, and human-made inventions” [32]. On the facts, the patent related to a man-made genetically engineered bacterium that was capable of breaking down multiple components of crude oil. This man-made bacterium possessed markedly different characteristics to that found in nature [32, 33]. It was a creation of human ingenuity and research of man and was not nature’s handiwork. On that basis, the US Supreme Court ruled that it was eligible for patent protection within the scope of § 101. The Court also affirmed that patentable subject matter includes “anything under the sun that is made by man.”

In adopting this expansive approach, the Court was influenced by Thomas Jefferson’s philosophy (embodied in the patent legislation) that “ingenuity should receive a liberal encouragement.” Yet, the Supreme Court did not overlook the long-standing precedents which affirmed the implicit exceptions. In reliance

on earlier precedents including its decision in *Funk Brothers Seed v Kalo Inoculant* (*Funk Brothers*), the Court reiterated that “the laws of nature, natural phenomena and abstract ideas” are not patentable subject matter [34].

In *Funk Brothers*, the patent claimed a mixture of naturally occurring strains of bacteria that helped leguminous plants to fix nitrogen from the air into the soil. The nitrogen-fixing abilities of these bacteria were well known, but their inhibitory effect on each other when mixed in a common base renders them unsuitable to be used in the same inoculant [35]. So the prevailing practice then was to manufacture separate inoculants that contain only one single species of the bacteria. The patentee discovered that not all of these bacteria exhibited inhibitive attributes toward each other. He proceeded to combine them into a single inoculant which formed the subject matter of the patent in question. The US Supreme Court held that the mixture/composition was not patent eligible as the state of “inhibition” or “non-inhibition” of the bacteria was not created by the patentee. It was the work of nature and, hence, not patentable. Since the patentee had not altered the bacteria in any way, the Court treated the claimed subject matter as a mere discovery of “a hitherto unknown phenomenon of nature” which could not be patentable. In denying patent eligibility, Justice Douglas compared the qualities of these bacteria to “the heat of the sun, electricity, or the qualities of metals” and held that they all form “part of the storehouse of knowledge of all men. They are manifestations of laws of nature, free to all men and reserved exclusively to none” [35].

Surprisingly, these rulings appeared to have been ignored in practice. To the contrary, the USPTO adopted an expansive approach to this issue after the *Chakrabarty* decision and granted patents to a “wide range of engineered DNA molecules” [19]. A few years later, the USPTO opened the door wider and started to issue patents that “claimed cDNA molecules in combination with other genetic materials” [19]. In subsequent years, a “patent-happy” [36, 37] USPTO began granting thousands of patents to “isolated DNA” on the basis that upon isolation from their natural cellular environment, they were no longer the “product of nature.”

It was not until 2009 that this long-standing practice of the USPTO was challenged by a group of medical researchers, advocacy groups, medical doctors, and patients. That case involved a claim relating to Myriad’s patents on “BRCA 1” and “BRCA 2” genes. This ultimately culminated in the groundbreaking US Supreme Court decision of *Myriad* which finally overturned several decades of liberal USPTO practice in granting gene patents, including those relating to isolated genomic DNA sequences [2].

3.2.2 Patent Eligibility of Human Genes: The Myriad Decision

Myriad’s scientists made a medical breakthrough when they discovered the precise location of the BRCA 1 and BRCA 2 genes on chromosomes 17 (comprising of approximately 80 million

nucleotides) and 13 (comprising around 114 million nucleotides). They also identified the approximately 80,000 nucleotides length of each of BRCA 1 and BRCA 2 genes [2]. Excluding introns, the exon-only cDNA sequence of BRCA 1 gene is only around 5500 nucleotides long and around 10,200 for BRCA 2 gene. This invaluable discovery contributed immensely to the development of medical tests for detecting mutations of these two genes which directly affects the risk profile of patients with respect to breast and ovarian cancers. Up to that point, the scientific community had accepted that heredity played a role in establishing these risks. However, it was unable to identify the precise genes which were associated with these cancers until Myriad's breakthrough [2].

Upon this finding, Myriad filed and obtained several patents including those related to the isolated genomic DNA and cDNA encoding for BRCA 1 and BRCA 2 genes. On the basis of these patents, Myriad purportedly had the exclusive right to isolate the BRCA 1 and BRCA 2 genes as well as synthetically create the BRCA cDNA. Since the isolation of the genes was an essential step in diagnostic testing, Myriad sought to enforce its patents against entities that were providing BRCA testing. If the patents were upheld, the overall effect would have been to allow Myriad to solidify "its position as the only entity providing BRCA testing" [2]. From a patient's standpoint, this would lead to higher cost for the Myriad BRCA test, as well as deny patients the option of a second medical opinion based on the Myriad test [2, 17]. The scientific research community may also be impeded from conducting further studies on the BRCA genes since there is "no meaningful" research exemption from patent infringement under the US law [38].

In June 2013, the US Supreme Court in remarkable unanimity issued a succinct judgment accepting the representation of the US Government and ruled that isolated genomic DNA was not patent eligible subject matter, but man-made cDNA are patent eligible. In denying patent eligibility to isolated genomic DNA as "product of nature," the nine justices held that Myriad had not created or altered the genetic information encoded in the genes. Indeed, the precise order of the nucleotide arrangements on the isolated genomic DNA remained the same as that which exists in nature. In contrast, the Court was persuaded that cDNA was patent eligible subject matter as the nucleotide sequence arrangement had been changed by man's removal of the introns from the genetic sequence. The resultant exon-only cDNA was dictated by man rather than nature.

By focusing on the "product of nature" limitation, Justice Thomas (who delivered the opinion of the Court) reaffirmed the well-established implicit exception to 35 USC § 101 that laws of nature, natural phenomena, and abstract ideas are not patentable. He stressed that these are "basic tools of scientific and technological work" that lie beyond the domain of patent protection [2].

Justice Thomas rightly reminded us of the importance of these limitations when he opined that:

Without this exception, there would be considerable danger that the grant of patents would “tie up” the use of such tools and thereby “inhibit future innovation premised upon them”... which would be at odds with the very point of patents, which exist to promote creation. [39]

However, the learned Justice also cautioned against adopting a limitless exclusion against patents on naturally occurring things. Since “all inventions at some level embody, use, reflect, rest upon, or apply laws of nature, natural phenomena, or abstract ideas,” an overly broad exclusionary principle may “eviscerate patent law.” The US Supreme Court rightly emphasized, what this author believes to be the crux in resolving this complex gene patent eligibility conundrum, namely, that the well-established rationale of patent protection must strike a delicate balance between:

“creating incentives that lead to creation, invention and discovery” and “[not] impeding the flow of information that might permit, indeed spur, invention” [2] [as well as, access for public health]. [40]

Although Justice Thomas did not expressly articulate the public interest/public health factor, he alluded to this issue in his judgment when he emphasized that if Myriad’s claim to isolated genomic DNA was held to be valid, it would have given Myriad the exclusive right to isolate the BRCA genes which forms an essential step in conducting genetic tests. This would in turn allow it to solidify “its position as the only entity providing BRCA testing” [2].

Unsurprisingly, the reactions to this momentous Supreme Court ruling were mixed and intense. Some applauded the decision proclaiming it as a “thrilling victory for patients” [41] and “great news for patients, doctors and scientific researchers” [42] and herald further innovation in the biotechnology industry. Others (mainly from the pharmaceutical and biotechnology industry) decried it as the doomsday of innovation [43]. Still others were less charitable and hurled personal attacks at the Justices, likening them to “Emperor without any clothes” [44].

4 Impact of the Myriad Decision on Vaccine Innovation

As the issue of patent eligibility specifically in relation to vaccines has yet to be addressed by the US Supreme Court, this part will attempt to extrapolate the influence that the recent *Myriad* decision is likely to have on the development of vaccines and the laws to which they relate.

For a start, several issues are clear. First, there is a retreat in law and practice to a more conservative stance on what constitutes patent eligible subject matter [45].

Second, the Court has reaffirmed the exclusion of “products of nature, natural phenomena, and abstract ideas” from patentability.

Third, the test of patentability is founded upon a distinction “between products of nature, whether living or not, and human-made inventions” [32].

Fourth, a rational basis on which such a distinction could be maintained would rest on whether modification to a given subject matter has resulted in a changed product which has characteristics or functions that differ from that which it was derived. The mere act of isolating or extracting a part of a “product of nature” from its natural environment would not constitute sufficient modification. Thus, traditional vaccines that contain unmodified virus, bacterium, or pathogen, whether dead or living, that are isolated from their natural environment are not patent eligible.

Fifth, the ingenuity of the discovery is irrelevant. Edward Jenner’s smallpox inoculate comprising of unmodified “matter obtained from the lesion” of a person infected with cowpox (a disease related to smallpox) was simply brilliant but is unlikely to receive a patent.

As vaccine products are often complex compositions that take many forms, its patent eligibility will largely depend on its composition. Some vaccines contain living or nonliving matter that has been altered to form a resultant synthetic product that is suitable for its purposes of inoculation. Modern vaccines that contain modified pathogens or their modified DNA may fall into this category. One example may be DNA or genetic immunization utilizing cDNA or recombinant DNA which is introduced “directly into a living host to generate an immune response” [46]. It was recently reported that scientists had created a new radical approach to HIV vaccination. Instead of training the immune system to fight an infection as in a traditional vaccine, the HIV vaccine alters the DNA of its host to instill the host cells with HIV-fighting properties [47]. Others include the recent clinical trials in human cancer treatment that utilize vaccines containing mutated tumor proteins [6, 7, 48, 49]. Modern vaccines that utilize cDNA or rDNA created by man are likely to be patent eligible subject matter under the *Myriad* ruling.

On the other hand, some critics may argue that the *Myriad* principles are inapplicable to microorganisms. They may consider isolated DNA of microorganisms as patentable. A summary of some of the reasons that may be advanced includes the following: (a) that the *Myriad* case was concerned only with human genes; (b) as the TRIPS Agreement mandates the patent protection of microorganisms, isolated DNA ought to enjoy similar treatment; (c) the

Court ruling in *Myriad* is distinguishable on the ground that the ethical issues related to human dignity and human rights do not apply to bacteria and viruses.

While this author does not dispute the factual distinctions, it is submitted that per se they do not offer anything more than artificial differences to justify a legal distinction between human and other nonhuman living organisms. Both human and microorganisms are living organisms. Even if a reasonable basis for the legal distinction can be established, it does not necessarily imply that an opposing answer is an inevitable result. In this respect, the *Chakrabarty* decision on microorganisms supports this inference elucidated above when the Court emphasized that the product of human ingenuity must possess markedly different characteristics to that found in nature in order to be patentable.

5 Access to Promote Future Innovation and for Public Health

The goal of the patent system is to strike an appropriate balance between the need to provide reward for innovation without jeopardizing the public access that is necessary to spur future innovation. The arguments canvassed by the proponents and critics of patent protection in relation to pharmaceutical products are well known and equally forceful. These have been adequately canvassed elsewhere, and only a brief evaluation of its impact on public health will be provided here [20].

The value of patents is directly derived from the ability to charge higher prices for the protected medicine and vaccines. This power results in an inverse relationship between the cost of such products and its affordability [50]. The need to maintain a sound balance between these goals is the imperative of ensuring that medicines can fulfill their “central role in improving their access to some and health for all” [20]. This argument is even more compelling in the case of vaccines. Vaccines play a central role in the fight against the threat to global public health through the rapid contagion of serious diseases in a highly connected world. The smallpox and polio vaccines serve as indisputable reminders. Indeed, when asked who owned the patent to his polio vaccine, Dr Jonas Salk’s surprising retort was “The people, I would say. There is no patent. Could you patent the sun?” [51–54]. Some suggest that Dr. Salk’s response may have been motivated by ethical or moral considerations. Others have gone further to hint that the vaccine could not have satisfied the patentability criteria based on the patent law of the day [51–54].

The discussion so far has focused on utilizing the issue of patent eligibility as a control mechanism to achieve the optimal balance. The patent system relies on other mechanisms to promote

access by introducing safeguards to prevent undesirable or unconscionable patent exploitation. Proposals within the patent system include compulsory licensing, parallel importation, patent pooling, research exemption, and second medical opinion defense among others. There are also useful suggestions that may be implemented outside the patent regime. These include innovation prizes and grants, health impact fund, drug donation, and government and international aid. These have already been deliberated elsewhere and will not be repeated here [20, 55].

It is important to emphasize that the maximizing of access for the promotion of public health involves a complex web of patent- and non-patent-related barriers. Patent is only one factor in the overall calculus. Non-patent-related obstacles which have been frequently cited as hindering access to medicines and vaccines include “poverty; corruption; civil strife, economic and societal problems, poor healthcare infrastructure, unskilled diagnostics and medical workforce; poor supply, distribution and delivery systems particularly to rural areas; substandard medicines; financial and administrative mismanagements, taxes and custom duties, complexity of medical therapy” among others [20]. Again, these have been evaluated elsewhere and are beyond the scope of this work [56, 57].

6 Conclusion: Striking an Appropriate Balance

The rapid advancement in science and technology, particularly in the field of biotechnology, has posed immense challenges to the patent system. The recent global challenges to the patenting of genes in many jurisdictions, including the USA, Australia, and Canada, illustrate the competing interests among the various stakeholders of the patent regime. While some have argued that the patent system may not be compatible with the fast-advancing developments in the field of genetics, others have advocated for the status quo.

At the end of the day, a robust and well-functioning patent system must be able to strike the most appropriate balance between the legitimate private interests of patent holders and the public interest. It should avert any negative perception of private interests being prioritized over public good of maximizing welfare and access to information for future innovation. The recent *Myriad* saga on the hotly contested BRCA gene patent serves as a timely reminder of this dilemma. Prior to the US Supreme Court ruling, many leading nations like the USA, countries of the European Union, Japan, and Australia had always taken a liberal approach toward patent eligibility of human genes. This included an expansive approach toward the protection of isolated genetic sequences. For several decades, this patent model was the accepted practice of

many patent offices worldwide. Then in a major twist of events, the USA has recently decided to depart from this long-established practice. The Supreme Court emphasized that the grant of patents to an isolated gene or other “basic building blocks of science and technology” may tilt the optimal balance in the patent equation too much against the need to preserve future innovation. This U-turn by the USA is an excellent validation of a patent system that is highly adaptable and capable of evolving to meet the future challenges by holding to its core principles that have the public interest at its center [58].

Acknowledgements

My sincere thanks to Victor Lim and Erwin Wan for research assistance and to my colleague Stephen Phua for invaluable editorial assistance. The views expressed and any errors are solely those of the author.

References and Notes

1. World Health Organization (1980) Global eradication of smallpox: final report of the global commission for the certification of smallpox eradication. Cited in Stefan Riedel S (2005) Edward Jenner and the history of smallpox and vaccination. *Proceedings (Baylor University Medical Center)* 18:21–25. <http://www.ncbi.nlm.nih.gov/pmc/articles/PMC1200696/>. Accessed 18 June 2015
2. *Association for Molecular Pathology v Myriad Genetics* (2013) S. Ct. 133: 2107
3. For example, confidential “know-how” protection, data exclusivity, copyright and patent
4. See, for example, Garrison C (2004) Intellectual property rights and vaccines in developing countries (background paper for WHO meeting)
5. See also Friede M (2010) Intellectual property and licence management with respect to vaccines. Paper presented at the World Health Organization Technology Transfer workshop
6. See, for example, the recent patent granted to Vaxon Biotech in Japan on optimized cryptic peptides used in the design of cancer vaccine for solid tumors reported in Editor (2015) Vaxon Biotech receives new patent in Japan for cancer vaccine candidate. *News Medical* at <http://www.news-medical.net/news/20150622/Vaxon-Biotech-receives-new-patent-in-Japan-for-cancer-vaccine-candidates.aspx>. Accessed 23 June 2015
7. See also Menez-Jamet J, Kosmatopoulos K (2009) Development of optimized cryptic peptides for immunotherapy. *IDrugs* 12(2):98–102
8. Ng ESK (2010) Immoral inventions – interaction between ethics and biotechnology patent law. *Sing Acad Law J* 22:931–947
9. Chisum D (2014) Chisum on patents. Matthew Bender Elite Products
10. Grubb P, Thomsen P (2010) Patents for chemicals, pharmaceuticals and biotechnology, 5th edn. Oxford University Press, New York
11. Bently L, Sherman B (2014) Intellectual property law, 4th edn. Oxford University Press, New York, NY
12. The freedom to practise an invention may be “limited by legislation or regulations having nothing to do with patents, or by the existence of other patents”. (49)
13. The manufacture and marketing of vaccines like other pharmaceutical products are regulated by the US Food and Drug Administration (US FDA). See US FDA web-site at <http://www.fda.gov/AboutFDA/Transparency/Basics/ucm194879.htm>. Accessed 27 June 2015
14. Palmer B (2014) Jonas Salk: good at virology, bad at economics. *Slate.com* at http://www.slate.com/articles/technology/history_of_innovation/2014/04/the_real_reasons_jonas_salk_didn_t_patent_the_polio_vaccine.html. Accessed 22 June 2015

15. Quinn G (2010) Emotion and anecdotes should not drive patent policy debate. IPWatchdog.com at http://www.ipwatchdog.com/2010/06/16/emotion-and-anecdotes-should-not-drive-patent-policy-debate/id=11260/?utm_source=feedburner&utm_medium=email&utm_campaign=Feed%3A+Ipwatchdog+%28IPWatchdog.com%29. Accessed 2 July 2015
16. Mayo Collaborative Services v Prometheus Labs Inc. (2012) S Ct. 132: 1289, 1305
17. Rai A (2014) Diagnostic patents at the supreme court. Marq Intell Prop Law Rev 18:1–9
18. Through representations by the National Institute of Health (“NIH”) and the US Office of Science and Technology Policy
19. Brief for the United States as amicus curiae in the Association for Molecular Pathology v Myriad Genetics (in the US Supreme Court)
20. These issues have been canvassed in the author’s earlier work and will not be repeated here. See Ng ESK (2009) Balancing patents and access to medicine. Sing Acad Law J 21:457–484
21. Palombi L (2009) Gene cartels, biotech patents in the age of free trade. Edward Elgar Publishing, Cheltenham
22. The complete text of the TRIPS Agreement is available on the WTO web-site at https://www.wto.org/english/docs_e/legal_e/27-trips_01_e.htm?l=it. Accessed 27 June 2015
23. Article 7 TRIPS Agreement
24. Article 27.1 TRIPS Agreement
25. Article 27.3(b) TRIPS Agreement
26. Gervais D (2012) TRIPS Agreement: drafting history and analysis, 4th edn. Sweet & Maxwell, London
27. Ng SK (1997) TRIPS Agreement and its implementation in relation to Singapore intellectual property law. Sing Acad Law J 9:334–361
28. See, for example, Ng ESK (2010) Immoral inventions: interaction between ethics and biotechnology patent law. Sing Acad Law J 22:931–947
29. See also Rangantha NV (2011) Patenting human genes: moral and ethical issues. Preserve articles online at <http://www.preservearticles.com/2011120618179/patenting-of-human-genes-moral-and-ethical-issues.html>. Accessed 23 June 2015
30. This decision was handed down one year before the Myriad case. For an excellent discussion, see Rai A (2014) Diagnostic patents at the supreme court. Marq Intell Prop Law Rev 18:1–9
31. Constitution of the US, Article I (section 8)
32. Diamond v Chakrabarty (1980) S. Ct. 100: 2204
33. Indeed, Dr Chakrabarty had discovered a process by which four different plasmids, capable of degrading four different oil components, could be transferred to and maintained with the requisite stability in a single Pseudomonas bacterium. The bacterium itself has no capacity for degrading oil
34. The US Supreme Court also cited the earlier decision of Parker v Flook (1978) U.S. 437: 584, among others
35. Funk Bros Seed v Kalo Inoculant (1948) S.Ct. 68: 440
36. See per Justice Elena Kagan who reportedly alluded to the USPTO as “patent-happy” at the US Supreme Court hearing of the Myriad case as reported in Bravin J (2013) Justices wary on gene patents. The Wall Street Journal at <http://www.wsj.com/articles/SB10001424127887324485004578424782830965300>. Accessed 26 June 2015
37. Lessy RE (2013) What is at stake in the Supreme Court decision in ‘AMP v Myriad Genetics’? The Nation News (June 5)
38. Conley J (2013) Myriad finally: Supreme Court surprises by not surprising. Genomics Law Report Online at <http://www.genomics-lawreport.com/index.php/2013/06/18/myriad-finally-supreme-court-surprises-by-not-surprising/>. Accessed 4 June 2015
39. Per Justice Thomas Association for Molecular Pathology v Myriad Genetics (2013) S. Ct. 133: 2107, 2116 where he cited in part from Mayo Collaborative Services v Prometheus Labs Inc. (2012) S Ct. 132: 1289
40. Words in bracket inserted by this author.
41. See American College of Medical Genetics and Genomics (ACMG) statement of June 13, 2013 at <https://www.acmg.net/docs/GenePatientsDecision.pdf>. Accessed 28 May 2015
42. Andrews L (2013) US Supreme Court liberates breast cancer genes. IIT Chicago-Kent Faculty blog at <http://blogs.kentlaw.iit.edu/faculty/2013/06/14/andrews-u-s-supreme-court-liberates-breast-cancer-gene> (accessed May 28, 2015). Andrews L filed amici curiae briefs on behalf of several medical organizations (including the American Medical Association, American Society of Human Genetics, American College of Obstetricians and Gynaecologists)
43. Zuhn D (2013) Reaction to Supreme Court’s decision in AMP v Myriad. Patent Docs online

- at <http://www.patentdocs.org/2013/07/reaction-to-supreme-courts-decision-in-amp-v-myrriad.html>. Accessed 28 May 2015
44. Quinn G (2015) Naked emperors: a supreme court patent tale. IP Watchdog blog at <http://www.ipwatchdog.com/2015/05/31/naked-emperors-a-supreme-court-patent-tale/id=58110>. Accessed 3 June 2015
 45. This more conservative approach of the US Supreme Court is also reflected in its decision on patent eligible subject-matter in other fields of technology, such as information technology. See the recent US Supreme Court decision of *Alice Corporation Pty Ltd v CLS Bank International* (2014) 573 U.S. (Slip opinion) at http://www.supremecourt.gov/opinions/13pdf/13-298_7lh8.pdf. Accessed 27 June 2015
 46. This may involve techniques aimed at stimulating the immune response to protein antigens by the “direct injection of genetic materials into a living host” causing some of its cells to produce the “introduced gene products; see the Editor, “What are DNA vaccines?” at <http://biology.kenyon.edu/slouc/bio38/scuderi/partii.html>. Accessed 30 May 2015
 47. Gallagher J (2015) HIV vaccine that transforms cell DNA brings fresh hope. BBC News website (February 18)
 48. Ledford H (2015) Tumor mutations harnessed to build cancer vaccine. *Nature* at <http://www.nature.com/news/tumour-mutations-harnessed-to-build-cancer-vaccine-1.17250>. Accessed 27 June 2015
 49. Senovilla L et al (2013) Trial watch: DNA vaccines for cancer therapy. *Oncoimmunology* 1:23803, <http://www.ncbi.nlm.nih.gov/pubmed/23734328>. Accessed 27 June 2015
 50. Lall S, Albaladejo M (2002) Indicators of the relative importance of IPRs in developing countries. Working paper no 85, Queen Elizabeth House working paper series QEHWPS85. pp 2–3
 51. See, for example, Bos, Carole "Jonas Salk – "Could You Patent the Sun?" " *AwesomeStories.com* at <http://www.awesomestories.com/asset/view/Jonas-Salk-Could-You-Patent-the-Sun>. Accessed 22 June 2015
 52. See also Brian Palmer, “Jonas Salk: Good at Virology, Bad at economics” (April 13, 2014) at http://www.slate.com/articles/technology/history_of_innovation/2014/04/the_real_reasons_jonas_salk_didn_t_patent_the_polio_vaccine.html. Accessed 22 June 2015
 53. Stephan Kinsela, “Patent and penicillin” (June 22, 2006) at <https://mises.org/blog/patent-and-penicillin>. Accessed 22 June 2015
 54. Jane Smith, *Patenting the Sun: Polio and the Salk Vaccine* (1980)
 55. Pogge T, Rimmer M, Rubenstein K (2010) Incentives for global public health: patent law and access to essential medicine. Cambridge University Press, Cambridge
 56. See, for example, WHO Commission on Macroeconomics and Health (2001)
 57. Mercurio B (2007) Resolving the public health crisis in the developing world: problems and barriers of access to essential medicines. *North-Western University J International Human Rights* 5:1–40; CIPR (2002) Integrating Intellectual Property Rights and Development Policy at <http://www.iprcommission.org>. Accessed 23 June 2015
 58. See WIPO Patent Agenda (A/36/14); WIPO Patent Agenda: options for development of the international patent, System (A/37/6)

INDEX

A

- Adaptive immunity.....79, 289
 Adenovirus 10, 12, 335
 Adjuvant..... 6, 7, 10, 15–17, 40, 43, 47, 125, 128, 129, 131,
 136, 154, 158–159, 162, 203, 208, 247, 253, 263,
 266, 271, 289–298, 301, 308, 378, 395, 417, 497,
 499, 501, 502, 506, 511, 526, 548, 549, 631, 636,
 638, 645, 683, 684, 697, 698, 700, 715, 716, 719,
 775, 781, 796, 820–824, 826, 828, 831
Aeromonad septicaemia203–208
Aeromonas sobria.....204–206, 208
 Ag85B378, 750
Agrobacterium tumefaciens.....551, 556, 581–595,
 597–599, 601, 603–605, 610, 611
 Allergy vaccine511
 Alphavirus313–326
 Analytic vaccinology..... 779, 781, 782
Anaplasma phagocytophilum 275, 276, 281–285
 Animal model.... 123–132, 167, 313, 314, 434, 530, 657, 671,
 708, 742, 777, 778
 Anthrax vaccine669
 Anti-arthropod vaccine262
 Antibiotic abuse.....301
 Antibiotic resistance 48, 193, 366, 369, 530, 583
 Antibody epitope mapping.....134
 Antibody readouts79–80
 Antigen..... 6, 7, 9–15, 19, 20, 24, 40, 51, 52, 55, 56, 59, 60
 screening.....281–285, 600
 Antigen-specific T cells 77–87, 530, 535
 Anti-*Hyalomma* vaccine.....459
 Anti-tick vaccine243–257, 261
 Antiviral DNA vaccines225–237
 Antiviral drugs.....104
 Aquaculture181, 203, 211, 225, 226
 Arenavirus
 GP-expressing cells 351, 352
 rescue systems351, 352
 reverse genetics352, 362
 Attachment protein104
 Avian metapneumovirus.....103–120

B

- Bacillus anthracis* 439, 451, 669, 680
 Baculovirus211–213, 365, 368, 438
 Baculovirus–insect cell system 365, 366, 368, 438
 BALB/c mice 66, 71, 142, 324–326, 426, 431,
 432, 434, 543, 552, 561, 565, 629, 716, 719
 Basic Local Alignment Search Tool (BLAST)..... 182, 184,
 187, 227, 237, 430, 472, 743
 B cells
 epitope prediction.....53
 immunity761
 BepiPred.....53, 54
 Betanodavirus211–222
 BHK-21 cells..... 315, 317, 319–323
 BioEdit sequence alignment editor53
 Bioinformatics 40, 139, 142, 143, 145, 149, 213,
 216–217, 275, 278, 280, 430, 431, 434, 550,
 727–738
 Biopanning423, 427
 BLAST. *See* Basic Local Alignment Search Tool (BLAST)
 Bone marrow derived dendritic cells (BMDC)698
Borrelia burgdorferi.....6
 Botulinum neurotoxin (BoNTs) 621, 622, 629, 630
 Botulism 621, 622
 Bovine tropical theileriosis.....459
C
 C57BL/6 mice..... 157, 325, 354, 359, 360, 502, 506,
 507, 537, 543
 Cancer vaccine..... 313, 774
Candida albicans..... 500–502, 504–508
 Candidiasis500–501
Carassius auratus langsdorffii.....194
 Carbohydrate vaccine 410, 547, 775
 Cathepsin 123, 135–137, 139–148
 Cationic peptides..... 290, 291, 294–297
 Cellular immunity 149, 162, 167, 170
 Ceramic hydroxyapatite chromatography 511, 513–517
 CFP10 gene..... 380, 381, 387, 390
 Chagas disease 683, 684

Chicken6, 7, 9, 11, 14, 22, 77–86, 89, 103,
165–176, 313, 736

Chicken viral vaccines77, 86

Chimeric flavivirus19

Chitosan16, 697–713

Chlamydia500

Cholera toxin B (CTB) subunit511–518, 548,
549, 553, 557, 562

Cholera vaccine511

Climate change135

Cloning.....40, 43, 45, 61–63, 72, 74, 90–95, 130, 139–140,
142–146, 148, 159, 161, 168–170, 188, 214,
217–219, 222, 228–229, 233, 235, 317, 353, 355,
369, 372, 390, 393, 439–444, 462–464, 469–471,
504, 516, 522, 526, 530, 533, 537, 551, 553–556,
563, 598–602, 609–610, 617, 624–626, 684–687

Clostridial toxin.....621

Clostridium botulinum621, 622, 624

ClustalW184, 230, 232, 248, 550, 552

Cold chain7, 166, 636

Competent DH5 α cells67, 68, 124, 127, 168, 171, 218,
231, 234, 338, 340, 465, 471–473, 488, 530, 685

Conformation-specific vaccines.....13

Copyright791, 795, 797–800, 809

Coronaviruses13

COS-7 cells142, 146–147, 172

CpG ODN289–298, 308

Current good manufacturing practice (cGMP)776, 779,
780, 782, 783

Cytotoxic CD8+ T cells (CTL).....14, 15, 78, 168, 353,
354, 363, 535, 538, 543, 651, 684

D

Data analysis.....81, 82, 250, 404, 448, 743

Degradation pathways394, 397, 400

Delta inulin410–411

Dendritic cell (DC)
 based therapy535–536
 vaccine289

Deoxyribonucleic acid (DNA)
 nanostructures.....301, 306–308, 310
 scaffolded vaccines.....301–310
 vaccine11, 59–75, 123, 135, 137, 138, 142, 145–147,
 149, 154, 155, 157–159, 165–169, 172, 176, 181,
 211, 225, 227, 230, 301, 314, 741–743, 745, 747,
 750, 751
 virus12, 227, 233, 581

Diagnostics581, 838, 845

DLS. *See* Dynamic light scattering (DLS)

DNAstar.....53, 213, 230, 464, 480

DNA vaccine database (DNAVaxDB).....741–751

DOLOP183, 187

Drug screening519–528

Drugs of abuse.....301

DsRed598, 600, 602, 607, 613

Dynamic light scattering (DLS).....400–401, 446,
450–451, 677, 709

E

Eastern blotting

Ebola virus.....108, 109, 313, 325, 597

EditSeq.....53, 54

Edward Jenner835, 836, 843

Electroporation.....17, 41, 44, 48, 124, 127, 316, 318–320,
466, 474, 505, 512, 514, 556, 584, 585, 592, 626,
630, 689

ELISA. *See* Enzyme linked immunosorbent assay (ELISA)

ELISpot.....79, 170, 173–175, 531, 535–538

Ellipro web server53

Emulsification635–649, 656

Enterotoxigenic *E. coli* (ETEC)511, 763

Enzyme linked immunosorbent assay (ELISA)62, 66,
71, 115, 124, 131, 155, 156, 160, 161, 169, 170,
173, 174, 195, 198–200, 229, 236, 249, 254, 262,
263, 267, 268, 272, 291, 296, 302, 304, 309, 310,
325, 371, 373, 429–431, 433, 434, 507, 552,
558–559, 607, 663, 678, 710, 712, 717, 720

EpiJen.....762–765, 767

EpiTOP762–764, 766, 767

Epitope11, 19, 21, 61, 148, 165, 168, 208, 211, 217,
253, 301, 334, 378, 394, 423, 431, 483–494, 519,
531, 532, 535, 536, 538, 741, 761–766, 818,
821–824, 831–833

Escherichia coli (*E. coli*)6–8, 11, 23, 27, 39–41, 44–46,
63, 64, 67, 68, 95, 124, 127, 136, 139, 143, 146,
148, 154, 156, 158, 161, 162, 168, 171, 211–215,
219, 231, 234, 262, 264, 282–283, 330–332, 336,
338, 340, 379, 381, 387, 388, 391, 424, 427–429,
437–455, 459–481, 483–485, 488, 490, 491, 493,
498, 501–507, 511–518, 520, 526, 530, 549, 558,
581, 599, 601, 602, 610, 622, 624, 626, 628, 630,
669, 672, 673, 685, 693

Excipient394–397, 399, 400, 403, 405, 406,
408, 410, 412, 413, 415, 775

F

Fasciola gigantica123, 135, 138

Fasciola hepatica.....123, 135, 136

Fasciolosis.....11, 123, 135–138

FASTA53, 55, 185–187, 232, 728, 755–758, 764–767

Filamentous bacteriophage.....423, 483–494

Fish pasteurellosis.....181–192

Fish vaccine193–201, 203, 206, 207

Flavivirus366–368, 370

Flow cytometry.....62, 70, 74, 79–82, 307–308, 334,
345, 536, 538, 540, 663, 665

Food and Drug Administration (FDA).....408, 773,
774, 777, 778, 780, 782–785, 808, 824–826, 828

Forced degradation394
 Formulation16, 23, 24, 40, 43, 61, 145, 167, 181, 247,
 249, 253, 289–298, 393–417, 424, 425, 431–433,
 514, 516, 624, 628, 631, 640, 644, 669–671, 673,
 675, 693, 697, 698, 700, 706, 710–712, 775, 779,
 792, 793, 796, 802, 816, 818, 822, 828, 831, 832
 Freeze-drying294, 397, 410–416, 643
 Freeze-thaw 332, 342, 346, 362, 394, 395, 410–416
 Fungal vaccine745
 Fusion chimeric gene550, 553
 Fusion protein62, 73, 75, 253, 270, 314, 381, 389,
 438, 440, 460, 503, 548–550, 552–553, 559, 561,
 563, 598, 613, 822–825

G

GeneMark 182, 185, 186, 191
 Gene stacking 598, 602, 609
 Genetic adjuvants166, 169
 Genetic vaccination61
 Ginbuna crucial carp194
 GLIMMER 182, 185, 186, 191
 Glycoprotein
 glycoprotein B (gB)89–100
 glycoprotein D (gD)89–100
 Guinea pig 378, 628, 781

H

HEK293 cells 317, 322, 323
 Hemagglutinin313, 366, 367, 393–417, 597
 Hepatitis A vaccine797
 Hepatitis B vaccine782, 797, 805
 Hepatitis B virus (HBV)378, 379, 437, 440, 483, 569
 Hepatitis B virus core VLP (HBc-VLP)377–391
 Hepatitis C virus (HCV)534, 762
 Heterologous gene-sequences370
 High Five cells 365, 368–373
 History of medicine24, 715
 Holotoxin511, 549
 Host microRNA response elements727–738
 Human cytomegalovirus (HCMV)170
 Human immunodeficiency virus (HIV) vaccine843
 Human leukocyte antigen (HLA)-typing 538, 753,
 754, 761
 Human papillomavirus (HPV)366, 437, 438, 440,
 483, 569, 651, 773
 Humoral immunity 154, 169, 194, 651
Hyalomma anatolicum 459–462, 469–470, 479
 Hybridoma363
 Hybrid particles483, 484

I

Immersion vaccine 18, 203–208
 Immobilized metal affinity chromatography
 (IMAC) 141, 511, 515, 517, 607, 613

Immune epitope database (IEDB) 762, 765, 766, 770
 Immune response7–9, 14–17, 22, 26, 51, 52, 60, 61,
 123, 131, 135–137, 139, 149, 153, 154, 165, 166,
 168, 173–176, 193, 194, 197, 198, 200, 211, 225,
 244, 245, 247, 253, 280, 289, 313, 325, 329, 365,
 378, 393, 423, 431–434, 498, 527, 535, 549, 612,
 631, 635, 638, 658–661, 671, 683, 684, 700, 712,
 715, 741, 742, 748, 762, 779, 794, 816, 823, 824,
 832, 843
 Immunofluorescence assay (IFA)92, 98
 Immunogenicity 11, 12, 19, 104, 105, 116–117, 168,
 247, 301, 302, 309, 314, 394, 412, 430, 437, 452,
 454, 483, 484, 529–545, 548, 671, 677, 715, 716,
 761–770, 777–781, 822

Immunoinformatics753
 Immunology 51, 80, 351, 708, 742, 762
 Immunoproteomics519, 524
 Immunotherapy289
 Infectious laryngotracheitis virus (ILTIV)10, 89–100
 Influenza vaccine366, 396, 397, 408, 410, 715
 Influenza virus 15, 77, 313
 Inhibition adherence assay 181, 182, 184–185
 Innate immunity 15, 61, 211
 Insect cells232, 247, 365–373, 406, 438
 Intellectual property (IP)791–810, 835–846
 strategy793, 803
 Intradermal (ID)131, 147, 165, 538, 652
 delivery715
 Intranasal vaccination697–713
 In vivo imaging62, 430
Ixodes scapularis275, 276, 278, 281, 282, 284, 285
 Ixodida250, 280

J

Japanese encephalitis vaccine367
 Japanese encephalitis virus365–373

K

Kozak sequence 61, 72, 167, 533

L

Lactic acid bacteria500
Lactobacillus casei 500, 501, 505, 507
 Lasergene108, 213
 LaSota vaccine strain 89, 90, 104
 LCMV. *See* Lymphocytic choriomeningitis virus (LCMV)
Leishmania vaccine6
 Lentiviral vectors537
 Lipofectamine65, 70, 91, 96, 97, 100, 106, 110,
 111, 146, 155, 157, 169, 172, 354, 532, 685, 687
 LipoP183, 187
 Liposome290–294, 297, 636, 644, 646, 651–667
 Liver disease131
 Liver flukes135–151

Live vaccine 12, 89, 199
Long-hairpin RNA 227
Long term protection 244
Luria-Bertani (LB) medium 41, 44, 63, 172, 231,
520, 623
Lyme disease 285
Lymphocytic choriomeningitis virus (LCMV) 351–363
Lyophilization 334, 393–396, 410, 412–414, 417, 628,
635–649, 680, 721

M

Maedi-visna virus (MVV) 59–75
Malaria vaccine 597–613
Measles 104, 773
Meningococcal vaccines 782
MetaMHC1pan 754, 759
MHC class I binding prediction 765–766
MHC I 79, 166, 538, 543, 754, 761–765
MHC II 52, 54, 56, 60, 166, 529, 754, 757,
758, 761, 762, 764, 765
MHC2MIL 754, 755, 757, 758
MHC2SKpan 754, 755, 757, 758
Microneedle arrays 651–667
Mimotope 423, 427, 431, 434
Modular cloning 602
Molecular display 497–509
Monoclonal antibodies (MAbs) 43, 78, 92, 98, 195,
196, 198–200, 597, 653, 761
Montanide 16, 253, 283
Motile *Aeromonas* species 204
Mucoadhesivity 697, 699, 700, 702, 705–706
Mucosal immune response 697, 707
Mucosal vaccine 651–667
Multivalent vaccines 20–21, 135, 824
Mumps 104
Mycobacterium bovis 6, 8, 12, 23–24, 743, 745–750
Mycobacterium tuberculosis (Mtb) 167, 377, 378, 380,
383, 387, 745–748, 750, 764–769
Mycoplasma hyopneumoniae 39–49

N

Nanoparticles 301, 485, 652, 674–680, 697–705,
708–711
Nanoparticle vaccine 669
Newcastle disease virus (NDV) 13, 89–100, 104,
108, 109, 167
Nicotiana benthamiana 582, 584, 587, 598, 605, 606,
608–609
Nipah virus 104
Nocardia seriolae 193–197, 199, 200
Nocardiosis 193, 194, 196
Nonhuman primates 762

O

One Health 24, 28
Oral immunization 17, 693
Oral rabies vaccine 547–565
Oral vaccine 10, 11, 22, 24, 497–509, 547, 549
Outer membrane protein (Omp) H 51–56
Ovine retrovirus 59

P

Paramyxoviridae 104, 108, 109
Pasteurella multocida 51–56
Patent 792, 794–799, 802, 806–809, 813–821, 824–830,
835–846
Patent law 795, 813, 814, 819, 820, 823, 835–838, 844
Pathogen 5–10, 12–17, 21–23, 25, 26, 39, 51, 52, 55,
77, 78, 103, 104, 153, 165–167, 176, 185, 193,
194, 196, 203, 204, 225, 226, 229, 230, 236, 261,
275, 280, 289, 329, 330, 367, 378, 432, 434, 437,
442, 511, 535, 542, 547, 548, 635, 651, 743,
745–747, 750, 753, 762, 775, 843
Pathogen-associated molecular patterns
(PAMPs) 15, 289, 529, 635, 683
pelB signal sequence 511
Penaeus monodon 226, 227, 232
Pentamer staining 535
Peptide binding 753, 762, 763, 765, 767
Peptide libraries 423
Peptide vaccine 51–56, 423–435
Perca fluviatilis 203–208
Perch 203–208
pET expression system 511
Phage display 423–435
Photobacteriosis 181
Photobacterium damsela subsp. *piscicida*
(*Pdp*) 181, 182, 184, 186, 188–191
Physicochemical degradation 393
Pichia pastoris expression system 124–127
Plague 805
Plant breeders' rights 794, 795, 800–801, 809
Plant expression vector 551, 553–556, 581–583, 601
Plasmid DNA vaccine 227, 774, 775
Plasmid Vaccine Ontology (VO) identifier 742
Plasmodium falciparum 597, 609, 612, 613
PLGA based nanoparticles 669, 671, 677
Pneumococcal vaccine 782
Polysaccharides 16, 786
Poly-ε-caprolactone 697–713
Post-transcriptional gene silencing (PTGS) 226, 582
Poultry 6, 9, 13, 17, 21, 22, 26, 52, 77, 89,
103, 104, 165, 169
Powder delivery 715–722
Prime-boost 12, 61, 62

Prokaryotic expression 212, 215, 219, 459–462, 476–478
 PROTEAN..... 43, 46, 53–55
 Proteasome cleavage..... 763
 Protective immune response 20, 137, 149, 669, 741, 822
 Protein display..... 498
 Protein H..... 52
 Protein vaccine 10, 11, 47, 135–137, 139–145,
 149, 154, 366, 377–391, 782
 Protozoa 7, 153, 683, 684
 pShuttle vectors 330–332, 335–336, 338–340, 347
 PSORT 183, 186, 187
 Public health..... 22, 154, 301, 715, 791, 792, 803, 804,
 806, 808, 837, 842, 844–845
 Pulmonary infection..... 329
 pVIII coat protein 484

R

Rabies 6, 17, 26, 548, 549, 553, 715, 794
 Rabies glycoprotein (RGP) 548–549, 552–554, 557–559
 Recombinant arenavirus 352
 Recombinant fd phage..... 484
 Recombinant PAD4..... 669, 671–672, 674, 679
 Recombinant protein production..... 124–125, 365
 Recombinant toxoid 622
 Recombinant vaccine..... 10, 11, 39–49, 175, 188,
 622, 628, 632
 Recombinant virus..... 91, 98, 105, 118, 321, 326, 332
 Replication-defective adenovirus vectors..... 329–348
 Reporter genes..... 61, 72, 321, 598
 Reporter virus..... 610
 Reverse genetics..... 89, 103–120
 Reverse vaccinology..... 39, 181–192, 246, 247
Rhabdoviridae 108, 109
Rhipicephalus (Boophilus) microplus..... 245, 261, 459
 Ricin 555–557
 Ricin toxin B (RTB) chain 549
Ricinus communis..... 549, 553, 555
 Rickettsiales 275
 RNA interference (RNAi)..... 225–237, 281, 284–285
 RNAmmer..... 183, 186
 RNA virus 13, 26, 72, 104, 108, 226, 227, 233,
 351, 352, 581
 Rotavirus 549

S

Saccharomyces cerevisiae..... 139, 143, 148, 438, 483, 498,
 499, 501, 503, 505–507, 529, 530, 532, 533, 549
 Salmonella vector 11, 683
 Secretory IgA (sIgA) 548, 697, 712
 Sheep..... 6, 59, 135, 138, 153, 154, 204, 250, 253,
 276, 460, 488
 Short-hairpin RNA..... 226–228
 Shrimp..... 225–237, 698

SignalP 40, 183, 187, 191
 Silicon wafer..... 653–655
 Single-cycle infectious arenavirus..... 352
 Site-directed mutagenesis..... 43–44, 105, 109–110
 Skin vaccination 715–722
 Sodium dodecyl sulfate-polyacrylamide gel electrophoresis
 (SDS-PAGE) 42, 45, 46, 125, 128, 141,
 145, 147, 158, 162, 213, 220–222, 264, 265, 270,
 271, 283, 322, 323, 389, 400, 407–411, 415, 416,
 441, 446, 447, 465, 467, 468, 473, 476, 479, 484,
 486–488, 491–492, 513–517, 524, 528, 531, 552,
 559, 560, 573, 576, 578, 590, 591, 607–609, 623,
 627, 630, 640, 646, 674, 781
 Stability 105, 114–116, 208, 228, 302, 304, 306–307,
 330, 333, 335, 346–348, 361, 378, 393–397,
 400–406, 410–417, 461, 612, 671, 698, 699, 782
 Structure-based vaccines..... 165
 Subunit vaccine..... 9, 10, 12, 15, 77, 154, 181, 225, 301,
 365, 378, 410–411, 547, 549, 635, 637, 741, 763
 Swine enzootic pneumonia..... 39
 Swiss-Prot 762
 Synthetic vaccine 301, 483
 Systems biology..... 275
 Systems vaccinology 742

T

TAP binding..... 763
 Tarmogen 529, 530, 533–538, 543
 T cells
 epitope 761, 763
 vaccine, 529–545
 TEPITOPEpan 754, 755, 757, 758
 Tetanus toxoid 208
 T_H-cell agretope prediction 54
Theileria annulata 459, 460
 T-helper cell 54, 60
 Therapeutic vaccine..... 537, 774, 777
 Thermal degradation 410, 415
 Tick-borne encephalitis..... 261
 Ticks
 control 243, 261–272
 vaccine, 275–285
 Tmpred..... 183
 Toxoid..... 621–632, 782
Toxoplasma gondii..... 6, 7, 153, 154, 157–159, 161, 162
 Toxoplasmosis..... 153–162
 Trademark 791, 793, 795, 797–798, 803, 807, 809
 Trade-Related Aspects of Intellectual Property Rights
 (TRIPs)..... 795, 805–806, 808, 837, 838, 843
 Transducing units 490–491
 Transgenic parasite 11
 Transient plant expression 597–613
 TrEMBL 762

- Trypanosoma cruzi* vaccine 683–685
Tuberculosis (TB)..... 6, 8, 12, 14, 24, 377–391, 745, 807
Tumor endothelial marker.....669
Tumor vaccine 325, 536–537
Turkey rhinotracheitis virus.....103
Type III secretion204
- U**
- UniProt.....762
United States Patent and Trade Mark Office
(USPTO)..... 814, 815, 818, 821, 829, 835,
839, 840
- V**
- Vaccine
design 55, 78, 329–348, 423–435, 671, 741–751
innovation.....791, 805
purification213
regulation.....570, 582, 605, 773, 778–781, 783, 785, 809
screening.....519–528
Vaccine adjuvant-delivery system (VADS)..... 635–649,
651–667
Vaccine-induced protective immunity548
Vaccine Investigation and Online Information Network
(VIOLIN)5, 741–743, 745, 747
Vaccinomics275–285
Vaxign.....748–751
Vaxijen.....762–764, 767
Vector purification..... 333, 337, 342–343
Vector quality control330, 334–335, 337–338, 344–346
Vero cells 106, 110–115, 117, 118, 157, 158, 362
Vesicular stomatitis virus 108, 109
Veterinary vaccine.....3–28
Vibrio cholerae..... 512, 553
Vibrio parahaemolyticus.....519, 520, 522–524, 527
VIOLIN. *See* Vaccine Investigation and Online Information
Network (VIOLIN)
Viral coat proteins 483, 569
Viral methyltransferase.....104
Viral molecular clone. 330, 332–334, 340, 341, 344, 346–348
Viral nervous necrosis (VNN).....211
Viral proteins..... 225, 313, 365, 393, 416, 438, 581–595
Viral rescue.....91, 96–97, 332, 334, 336–337, 341–342, 347,
348, 352, 356, 362
Viral vaccine vectors 351–363, 782
Virus like particles (VLPs)
analysis.....448–453
purification, 445–446
Virus vector 10, 19, 21, 40, 352, 353, 358, 359, 362, 363, 581
Visceral leishmaniasis6
- W**
- Water-borne diseases.....204
Web Ontology Language (OWL).....751
Western blotting..... 46–47, 147, 157, 169, 173, 236,
322, 371, 372, 488, 493, 521, 524, 560, 573, 576,
578, 781
World Trade Organization (WTO)837, 838
- Y**
- Yellow fever vaccine.....367
- Z**
- Zoonotic diseases.....6, 11, 21, 23, 135