

C# 6.0 and the .NET 4.6 Framework

Seventh Edition

Andrew Troelsen
Philip Japikse

Apress®

C# 6.0 and the .NET 4.6 Framework

Seventh Edition



Andrew Troelsen

Philip Japikse

Apress®

C# 6.0 and the .NET 4.6 Framework

Copyright © 2015 by Andrew Troelsen and Philip Japikse

This work is subject to copyright. All rights are reserved by the Publisher, whether the whole or part of the material is concerned, specifically the rights of translation, reprinting, reuse of illustrations, recitation, broadcasting, reproduction on microfilms or in any other physical way, and transmission or information storage and retrieval, electronic adaptation, computer software, or by similar or dissimilar methodology now known or hereafter developed. Exempted from this legal reservation are brief excerpts in connection with reviews or scholarly analysis or material supplied specifically for the purpose of being entered and executed on a computer system, for exclusive use by the purchaser of the work. Duplication of this publication or parts thereof is permitted only under the provisions of the Copyright Law of the Publisher's location, in its current version, and permission for use must always be obtained from Springer. Permissions for use may be obtained through RightsLink at the Copyright Clearance Center. Violations are liable to prosecution under the respective Copyright Law.

ISBN-13 (pbk): 978-1-4842-1333-9

ISBN-13 (electronic): 978-1-4842-1332-2

Trademarked names, logos, and images may appear in this book. Rather than use a trademark symbol with every occurrence of a trademarked name, logo, or image we use the names, logos, and images only in an editorial fashion and to the benefit of the trademark owner, with no intention of infringement of the trademark.

The use in this publication of trade names, trademarks, service marks, and similar terms, even if they are not identified as such, is not to be taken as an expression of opinion as to whether or not they are subject to proprietary rights.

While the advice and information in this book are believed to be true and accurate at the date of publication, neither the authors nor the editors nor the publisher can accept any legal responsibility for any errors or omissions that may be made. The publisher makes no warranty, express or implied, with respect to the material contained herein.

Managing Director: Welmoed Spahr

Lead Editor: James DeWolf

Technical Reviewer: Andy Olsen

Development Editor: Douglas Pundick

Editorial Board: Steve Anglin, Mark Beckner, Gary Cornell, Louise Corrigan, Jim DeWolf,

Jonathan Gennick, Robert Hutchinsson, Michelle Lowman, James Markham, Susan McDermott,

Matthew Moodie, Jeffrey Pepper, Douglas Pundick, Ben Renow-Clarke, Gwenan Spearing,

Matt Wade, Steve Weiss

Coordinating Editor: Melissa Maldonado

Copy Editors: Mary Behr, Kim Wimpsett

Compositor: SPi Global

Indexer: SPi Global

Artist: SPi Global

Distributed to the book trade worldwide by Springer Science+Business Media New York, 233 Spring Street, 6th Floor, New York, NY 10013. Phone 1-800-SPRINGER, fax (201) 348-4505, e-mail orders-ny@springer-sbm.com, or visit www.springer.com. Apress Media, LLC is a California LLC and the sole member (owner) is Springer Science + Business Media Finance Inc (SSBM Finance Inc). SSBM Finance Inc is a Delaware corporation.

For information on translations, please e-mail rights@apress.com, or visit www.apress.com.

Apress and friends of ED books may be purchased in bulk for academic, corporate, or promotional use. eBook versions and licenses are also available for most titles. For more information, reference our Special Bulk Sales—eBook Licensing web page at www.apress.com/bulk-sales.

Any source code or other supplementary material referenced by the author in this text is available to readers at www.apress.com. For detailed information about how to locate your book's source code, go to www.apress.com/source-code/.

*To the entire Troelsen clan: Mary (mom), Walter (dad), Mandy (wife), and Soren (son).
We miss you, Mikko (the cat). —Andrew*

*To my family, Amy (wife), Conner (son), Logan (son), and Skylar (daughter), thank you
for all of the support and patience you have given me. —Philip*

Contents at a Glance

| | |
|--|--------------|
| About the Authors | lvii |
| About the Technical Reviewer | lix |
| Acknowledgments | lxi |
| Introduction | lxiii |
| ■ Part I: Introducing C# and the .NET Platform | 1 |
| ■ Chapter 1: The Philosophy of .NET..... | 3 |
| ■ Chapter 2: Building C# Applications | 35 |
| ■ Part II: Core C# Programming | 59 |
| ■ Chapter 3: Core C# Programming Constructs, Part I | 61 |
| ■ Chapter 4: Core C# Programming Constructs, Part II | 109 |
| ■ Part III: Object-Oriented Programming with C# | 149 |
| ■ Chapter 5: Understanding Encapsulation | 151 |
| ■ Chapter 6: Understanding Inheritance and Polymorphism..... | 205 |
| ■ Chapter 7: Understanding Structured Exception Handling | 247 |
| ■ Chapter 8: Working with Interfaces | 275 |
| ■ Part IV: Advanced C# Programming | 313 |
| ■ Chapter 9: Collections and Generics..... | 315 |
| ■ Chapter 10: Delegates, Events, and Lambda Expressions | 355 |

- **Chapter 11: Advanced C# Language Features** 399
- **Chapter 12: LINQ to Objects**..... 439
- **Chapter 13: Understanding Object Lifetime**..... 473

- **Part V: Programming with .NET Assemblies**..... 501
- **Chapter 14: Building and Configuring Class Libraries**..... 503
- **Chapter 15: Type Reflection, Late Binding, and Attribute-Based Programming** 555
- **Chapter 16: Dynamic Types and the Dynamic Language Runtime** 599
- **Chapter 17: Processes, AppDomains, and Object Contexts** 623
- **Chapter 18: Understanding CIL and the Role of Dynamic Assemblies**..... 651

- **Part VI: Introducing the .NET Base Class Libraries** 693
- **Chapter 19: Multithreaded, Parallel, and Async Programming** 695
- **Chapter 20: File I/O and Object Serialization**..... 749
- **Chapter 21: ADO.NET Part I: The Connected Layer**..... 799
- **Chapter 22: ADO.NET Part II: The Disconnected Layer**..... 859
- **Chapter 23: ADO.NET Part III: Entity Framework** 929
- **Chapter 24: Introducing LINQ to XML** 1001
- **Chapter 25: Introducing Windows Communication Foundation** 1021

- **Part VII: Windows Presentation Foundation** 1083
- **Chapter 26: Introducing Windows Presentation Foundation and XAML**..... 1085
- **Chapter 27: Programming with WPF Controls**..... 1147
- **Chapter 28: WPF Graphics Rendering Services** 1229
- **Chapter 29: WPF Resources, Animations, Styles, and Templates**..... 1277
- **Chapter 30: Notifications, Commands, Validation, and MVVM** 1329

■ **Part VIII: ASP.NET** **1383**

■ **Chapter 31: Introducing ASP.NET Web Forms** **1385**

■ **Chapter 32: ASP.NET Web Controls, Master Pages, and Themes** **1435**

■ **Chapter 33: ASP.NET State Management Techniques** **1491**

■ **Chapter 34: ASP.NET MVC and Web API** **1527**

Index **1603**

Contents

| | |
|---|--------------|
| About the Authors | lvii |
| About the Technical Reviewer | lix |
| Acknowledgments | lxi |
| Introduction | lxiii |
| ■ Part I: Introducing C# and the .NET Platform | 1 |
| ■ Chapter 1: The Philosophy of .NET | 3 |
| An Initial Look at the .NET Platform..... | 3 |
| Some Key Benefits of the .NET Platform | 4 |
| Introducing the Building Blocks of the .NET Platform (the CLR, CTS, and CLS)..... | 4 |
| The Role of the Base Class Libraries | 5 |
| What C# Brings to the Table..... | 5 |
| Managed vs. Unmanaged Code | 7 |
| Additional .NET-Aware Programming Languages..... | 8 |
| Life in a Multilanguage World | 8 |
| An Overview of .NET Assemblies..... | 9 |
| The Role of the Common Intermediate Language | 10 |
| Benefits of CIL | 12 |
| Compiling CIL to Platform-Specific Instructions..... | 12 |
| The Role of .NET Type Metadata | 13 |
| The Role of the Assembly Manifest | 14 |
| Understanding the Common Type System..... | 14 |
| CTS Class Types..... | 15 |
| CTS Interface Types | 15 |

| | |
|--|-----------|
| CTS Structure Types | 16 |
| CTS Enumeration Types | 16 |
| CTS Delegate Types | 17 |
| CTS Type Members | 17 |
| Intrinsic CTS Data Types | 17 |
| Understanding the Common Language Specification | 18 |
| Ensuring CLS Compliance..... | 20 |
| Understanding the Common Language Runtime..... | 20 |
| The Assembly/Namespace/Type Distinction..... | 22 |
| The Role of the Microsoft Root Namespace | 23 |
| Accessing a Namespace Programmatically | 25 |
| Referencing External Assemblies | 26 |
| Exploring an Assembly Using ildasm.exe | 27 |
| Viewing CIL Code | 28 |
| Viewing Type Metadata..... | 29 |
| Viewing Assembly Metadata (aka the Manifest)..... | 30 |
| The Platform-Independent Nature of .NET | 31 |
| The Mono Project | 32 |
| Microsoft .NET Core | 32 |
| Summary..... | 33 |
| ■ Chapter 2: Building C# Applications..... | 35 |
| Building C# Applications on the Windows OS | 35 |
| The Visual Studio Express Family of IDEs | 36 |
| The Visual Studio Community Edition IDE..... | 44 |
| The Visual Studio 2015 Professional IDE | 50 |
| The .NET Framework Documentation System | 50 |
| Building .NET Applications Beyond the Windows OS..... | 53 |
| The Role of Xamarin Studio | 53 |
| Summary..... | 57 |

| | |
|---|-----------|
| ■ Part II: Core C# Programming..... | 59 |
| ■ Chapter 3: Core C# Programming Constructs, Part I | 61 |
| The Anatomy of a Simple C# Program..... | 61 |
| Variations on the Main() Method..... | 63 |
| Specifying an Application Error Code | 64 |
| Processing Command-Line Arguments | 65 |
| Specifying Command-Line Arguments with Visual Studio..... | 66 |
| An Interesting Aside: Some Additional Members of the System.Environment Class..... | 67 |
| The System.Console Class | 69 |
| Basic Input and Output with the Console Class..... | 69 |
| Formatting Console Output..... | 71 |
| Formatting Numerical Data | 71 |
| Formatting Numerical Data Beyond Console Applications | 73 |
| System Data Types and Corresponding C# Keywords | 74 |
| Variable Declaration and Initialization | 75 |
| Intrinsic Data Types and the new Operator..... | 77 |
| The Data Type Class Hierarchy | 77 |
| Members of Numerical Data Types..... | 79 |
| Members of System.Boolean..... | 80 |
| Members of System.Char | 80 |
| Parsing Values from String Data..... | 81 |
| System.DateTime and System.TimeSpan..... | 81 |
| The System.Numerics.dll Assembly | 82 |
| Working with String Data | 83 |
| Basic String Manipulation..... | 84 |
| String Concatenation | 85 |
| Escape Characters..... | 86 |
| Defining Verbatim Strings..... | 87 |
| Strings and Equality..... | 87 |
| Strings Are Immutable | 88 |

| | |
|--|------------|
| The System.Text.StringBuilder Type | 89 |
| String Interpolation | 90 |
| Narrowing and Widening Data Type Conversions | 91 |
| The checked Keyword | 94 |
| Setting Project-wide Overflow Checking | 95 |
| The unchecked Keyword | 96 |
| Understanding Implicitly Typed Local Variables | 97 |
| Restrictions on Implicitly Typed Variables | 98 |
| Implicit Typed Data Is Strongly Typed Data | 99 |
| Usefulness of Implicitly Typed Local Variables | 100 |
| C# Iteration Constructs | 101 |
| The for Loop | 101 |
| The foreach Loop | 102 |
| Use of Implicit Typing Within foreach Constructs | 102 |
| The while and do/while Looping Constructs | 103 |
| Decision Constructs and the Relational/Equality Operators | 104 |
| The if/else Statement | 104 |
| Equality and Relational Operators | 104 |
| Conditional Operators | 105 |
| The switch Statement | 105 |
| Summary | 108 |
| ■ Chapter 4: Core C# Programming Constructs, Part II | 109 |
| Methods and Parameter Modifiers | 109 |
| The Default by Value Parameter-Passing Behavior | 110 |
| The out Modifier | 111 |
| The ref Modifier | 112 |
| The params Modifier | 114 |
| Defining Optional Parameters | 115 |

| | |
|---|------------|
| Invoking Methods Using Named Parameters..... | 116 |
| Understanding Method Overloading | 118 |
| Understanding C# Arrays..... | 120 |
| C# Array Initialization Syntax | 121 |
| Implicitly Typed Local Arrays | 122 |
| Defining an Array of Objects | 123 |
| Working with Multidimensional Arrays..... | 124 |
| Arrays As Arguments or Return Values | 125 |
| The System.Array Base Class..... | 126 |
| Understanding the enum Type..... | 127 |
| Controlling the Underlying Storage for an enum | 129 |
| Declaring enum Variables..... | 129 |
| The System.Enum Type..... | 130 |
| Dynamically Discovering an enum’s Name/Value Pairs | 131 |
| Understanding the Structure (aka Value Type) | 133 |
| Creating Structure Variables..... | 135 |
| Understanding Value Types and Reference Types | 136 |
| Value Types, References Types, and the Assignment Operator..... | 137 |
| Value Types Containing Reference Types..... | 139 |
| Passing Reference Types by Value..... | 141 |
| Passing Reference Types by Reference..... | 142 |
| Final Details Regarding Value Types and Reference Types..... | 143 |
| Understanding C# Nullable Types..... | 144 |
| Working with Nullable Types | 145 |
| The Null Coalescing Operator | 146 |
| The Null Conditional Operator..... | 147 |
| Summary..... | 148 |

■ **Part III: Object-Oriented Programming with C#** 149

■ **Chapter 5: Understanding Encapsulation** 151

 Introducing the C# Class Type 151

 Allocating Objects with the new Keyword 154

Understanding Constructors..... 155

 The Role of the Default Constructor 155

 Defining Custom Constructors 156

 The Default Constructor Revisited 157

The Role of the this Keyword 159

 Chaining Constructor Calls Using this 161

 Observing Constructor Flow 163

 Revisiting Optional Arguments 165

Understanding the static Keyword 166

 Defining Static Field Data 167

 Defining Static Methods 169

 Defining Static Constructors..... 170

 Defining Static Classes..... 173

 Importing Static Members via the C# using Keyword 174

Defining the Pillars of OOP 175

 The Role of Encapsulation 175

 The Role of Inheritance..... 175

 The Role of Polymorphism..... 177

C# Access Modifiers 179

 The Default Access Modifiers 179

 Access Modifiers and Nested Types 180

The First Pillar: C#'s Encapsulation Services 181

 Encapsulation Using Traditional Accessors and Mutators 182

 Encapsulation Using .NET Properties 184

 Using Properties Within a Class Definition..... 187

 Read-Only and Write-Only Properties..... 189

 Revisiting the static Keyword: Defining Static Properties 190

| | |
|---|------------|
| Understanding Automatic Properties..... | 190 |
| Interacting with Automatic Properties | 192 |
| Automatic Properties and Default Values | 192 |
| Initialization of Automatic Properties..... | 194 |
| Understanding Object Initialization Syntax..... | 195 |
| Calling Custom Constructors with Initialization Syntax | 197 |
| Initializing Data with Initialization Syntax..... | 198 |
| Working with Constant Field Data | 199 |
| Understanding Read-Only Fields | 201 |
| Static Read-Only Fields | 201 |
| Understanding Partial Classes | 202 |
| Use Cases for Partial Classes? | 203 |
| Summary..... | 204 |
| ■ Chapter 6: Understanding Inheritance and Polymorphism..... | 205 |
| The Basic Mechanics of Inheritance | 205 |
| Specifying the Parent Class of an Existing Class..... | 206 |
| Regarding Multiple Base Classes | 208 |
| The sealed Keyword | 208 |
| Revising Visual Studio Class Diagrams | 210 |
| The Second Pillar of OOP: The Details of Inheritance | 212 |
| Controlling Base Class Creation with the base Keyword | 213 |
| Keeping Family Secrets: The protected Keyword | 215 |
| Adding a Sealed Class | 216 |
| Programming for Containment/Delegation..... | 217 |
| Understanding Nested Type Definitions..... | 218 |
| The Third Pillar of OOP: C#'s Polymorphic Support | 220 |
| The virtual and override Keywords..... | 221 |
| Overriding Virtual Members Using the Visual Studio IDE | 223 |
| Sealing Virtual Members..... | 225 |
| Understanding Abstract Classes..... | 225 |

| | |
|---|------------|
| Understanding the Polymorphic Interface | 228 |
| Understanding Member Shadowing | 232 |
| Understanding Base Class/Derived Class Casting Rules..... | 234 |
| The C# as Keyword | 235 |
| The C# is Keyword | 237 |
| The Master Parent Class: System.Object | 237 |
| Overriding System.Object.ToString() | 240 |
| Overriding System.Object.Equals()..... | 241 |
| Overriding System.Object.GetHashCode() | 242 |
| Testing Your Modified Person Class..... | 243 |
| The Static Members of System.Object | 244 |
| Summary..... | 245 |
| ■ Chapter 7: Understanding Structured Exception Handling | 247 |
| Ode to Errors, Bugs, and Exceptions | 247 |
| The Role of .NET Exception Handling | 248 |
| The Building Blocks of .NET Exception Handling | 249 |
| The System.Exception Base Class..... | 249 |
| The Simplest Possible Example | 251 |
| Throwing a General Exception..... | 253 |
| Catching Exceptions | 254 |
| Configuring the State of an Exception..... | 256 |
| The TargetSite Property | 256 |
| The StackTrace Property..... | 257 |
| The HelpLink Property | 257 |
| The Data Property..... | 258 |
| System-Level Exceptions (System.SystemException)..... | 260 |
| Application-Level Exceptions (System.ApplicationException)..... | 261 |
| Building Custom Exceptions, Take 1 | 261 |
| Building Custom Exceptions, Take 2..... | 263 |
| Building Custom Exceptions, Take 3..... | 264 |

| | |
|--|------------|
| Processing Multiple Exceptions | 265 |
| General catch Statements | 268 |
| Rethrowing Exceptions..... | 268 |
| Inner Exceptions | 269 |
| The finally Block | 270 |
| Exception Filters | 271 |
| Debugging Unhandled Exceptions Using Visual Studio | 272 |
| Summary | 273 |
| ■ Chapter 8: Working with Interfaces | 275 |
| Understanding Interface Types..... | 275 |
| Interface Types vs. Abstract Base Classes..... | 276 |
| Defining Custom Interfaces..... | 278 |
| Implementing an Interface | 281 |
| Invoking Interface Members at the Object Level..... | 283 |
| Obtaining Interface References: The as Keyword..... | 284 |
| Obtaining Interface References: The is Keyword..... | 284 |
| Interfaces As Parameters | 285 |
| Interfaces As Return Values | 287 |
| Arrays of Interface Types..... | 288 |
| Implementing Interfaces Using Visual Studio..... | 289 |
| Explicit Interface Implementation | 291 |
| Designing Interface Hierarchies | 293 |
| Multiple Inheritance with Interface Types..... | 295 |
| The IEnumerable and IEnumerator Interfaces..... | 297 |
| Building Iterator Methods with the yield Keyword..... | 300 |
| Building a Named Iterator..... | 301 |
| The ICloneable Interface..... | 302 |
| A More Elaborate Cloning Example..... | 304 |

| | |
|---|------------|
| The IComparable Interface | 307 |
| Specifying Multiple Sort Orders with IComparer | 310 |
| Custom Properties and Custom Sort Types..... | 311 |
| Summary..... | 312 |
| ■ Part IV: Advanced C# Programming | 313 |
| ■ Chapter 9: Collections and Generics..... | 315 |
| The Motivation for Collection Classes | 315 |
| The System.Collections Namespace | 317 |
| A Survey of System.Collections.Specialized Namespace..... | 318 |
| The Problems of Nongeneric Collections | 319 |
| The Issue of Performance..... | 320 |
| The Issue of Type Safety..... | 323 |
| A First Look at Generic Collections..... | 326 |
| The Role of Generic Type Parameters | 327 |
| Specifying Type Parameters for Generic Classes/Structures | 328 |
| Specifying Type Parameters for Generic Members..... | 330 |
| Specifying Type Parameters for Generic Interfaces..... | 330 |
| The System.Collections.Generic Namespace | 331 |
| Understanding Collection Initialization Syntax | 333 |
| Working with the List<T> Class | 334 |
| Working with the Stack<T> Class..... | 336 |
| Working with the Queue<T> Class..... | 337 |
| Working with the SortedSet<T> Class | 338 |
| Working with the Dictionary<TKey, TValue> Class..... | 340 |
| The System.Collections.ObjectModel Namespace | 341 |
| Working with ObservableCollection<T>..... | 341 |
| Creating Custom Generic Methods..... | 343 |
| Inference of Type Parameters..... | 346 |

| | |
|---|------------|
| Creating Custom Generic Structures and Classes..... | 347 |
| The default Keyword in Generic Code..... | 349 |
| Constraining Type Parameters..... | 350 |
| Examples Using the where Keyword..... | 351 |
| The Lack of Operator Constraints..... | 352 |
| Summary..... | 353 |
| ■ Chapter 10: Delegates, Events, and Lambda Expressions | 355 |
| Understanding the .NET Delegate Type | 355 |
| Defining a Delegate Type in C#..... | 356 |
| The System.MulticastDelegate and System.Delegate Base Classes..... | 359 |
| The Simplest Possible Delegate Example | 360 |
| Investigating a Delegate Object..... | 362 |
| Sending Object State Notifications Using Delegates..... | 363 |
| Enabling Multicasting..... | 366 |
| Removing Targets from a Delegate's Invocation List..... | 368 |
| Method Group Conversion Syntax | 369 |
| Understanding Generic Delegates..... | 371 |
| The Generic Action<> and Func<> Delegates..... | 372 |
| Understanding C# Events | 374 |
| The C# event Keyword..... | 376 |
| Events Under the Hood..... | 377 |
| Listening to Incoming Events..... | 378 |
| Simplifying Event Registration Using Visual Studio..... | 380 |
| Cleaning Up Event Invocation Using the C# 6.0 Null-Conditional Operator | 381 |
| Creating Custom Event Arguments..... | 382 |
| The Generic EventHandler<T> Delegate..... | 384 |
| Understanding C# Anonymous Methods | 385 |
| Accessing Local Variables | 387 |

| | |
|--|------------|
| Understanding Lambda Expressions | 388 |
| Dissecting a Lambda Expression..... | 391 |
| Processing Arguments Within Multiple Statements..... | 392 |
| Lambda Expressions with Multiple (or Zero) Parameters..... | 393 |
| Retrofitting the CarEvents Example Using Lambda Expressions..... | 395 |
| Lambdas and Single Statement Member Implementations | 395 |
| Summary..... | 397 |
| ■ Chapter 11: Advanced C# Language Features | 399 |
| Understanding Indexer Methods | 399 |
| Indexing Data Using String Values..... | 401 |
| Overloading Indexer Methods..... | 402 |
| Indexers with Multiple Dimensions | 403 |
| Indexer Definitions on Interface Types..... | 404 |
| Understanding Operator Overloading | 404 |
| Overloading Binary Operators..... | 405 |
| And What of the += and -- Operators? | 408 |
| Overloading Unary Operators..... | 408 |
| Overloading Equality Operators | 409 |
| Overloading Comparison Operators..... | 410 |
| Final Thoughts Regarding Operator Overloading..... | 411 |
| Understanding Custom Type Conversions | 411 |
| Recall: Numerical Conversions | 412 |
| Recall: Conversions Among Related Class Types..... | 412 |
| Creating Custom Conversion Routines | 413 |
| Additional Explicit Conversions for the Square Type..... | 416 |
| Defining Implicit Conversion Routines..... | 417 |
| Understanding Extension Methods..... | 418 |
| Defining Extension Methods..... | 419 |
| Invoking Extension Methods..... | 420 |
| Importing Extension Methods..... | 421 |

| | |
|---|------------|
| The IntelliSense of Extension Methods..... | 422 |
| Extending Types Implementing Specific Interfaces | 422 |
| Understanding Anonymous Types | 424 |
| Defining an Anonymous Type..... | 424 |
| The Internal Representation of Anonymous Types..... | 425 |
| The Implementation of ToString() and GetHashCode()..... | 427 |
| The Semantics of Equality for Anonymous Types | 427 |
| Anonymous Types Containing Anonymous Types | 429 |
| Working with Pointer Types..... | 429 |
| The unsafe Keyword..... | 431 |
| Working with the * and & Operators..... | 433 |
| An Unsafe (and Safe) Swap Function | 434 |
| Field Access via Pointers (the -> Operator)..... | 435 |
| The stackalloc Keyword..... | 435 |
| Pinning a Type via the fixed Keyword | 436 |
| The sizeof Keyword | 437 |
| Summary..... | 437 |
| ■ Chapter 12: LINQ to Objects..... | 439 |
| LINQ-Specific Programming Constructs..... | 439 |
| Implicit Typing of Local Variables | 440 |
| Object and Collection Initialization Syntax..... | 440 |
| Lambda Expressions..... | 441 |
| Extension Methods | 442 |
| Anonymous Types..... | 443 |
| Understanding the Role of LINQ | 443 |
| LINQ Expressions Are Strongly Typed | 444 |
| The Core LINQ Assemblies..... | 444 |
| Applying LINQ Queries to Primitive Arrays | 445 |
| Once Again, Without LINQ | 447 |
| Reflecting over a LINQ Result Set..... | 447 |

| | |
|--|------------|
| LINQ and Implicitly Typed Local Variables | 448 |
| LINQ and Extension Methods..... | 449 |
| The Role of Deferred Execution | 450 |
| The Role of Immediate Execution | 451 |
| Returning the Result of a LINQ Query..... | 452 |
| Returning LINQ Results via Immediate Execution | 453 |
| Applying LINQ Queries to Collection Objects..... | 454 |
| Accessing Contained Subobjects | 455 |
| Applying LINQ Queries to Nongeneric Collections | 456 |
| Filtering Data Using OfType<T>() | 457 |
| Investigating the C# LINQ Query Operators..... | 457 |
| Basic Selection Syntax | 459 |
| Obtaining Subsets of Data | 460 |
| Projecting New Data Types | 460 |
| Obtaining Counts Using Enumerable | 462 |
| Reversing Result Sets..... | 462 |
| Sorting Expressions..... | 463 |
| LINQ As a Better Venn Diagramming Tool | 463 |
| Removing Duplicates..... | 465 |
| LINQ Aggregation Operations..... | 465 |
| The Internal Representation of LINQ Query Statements..... | 466 |
| Building Query Expressions with Query Operators (Revisited)..... | 467 |
| Building Query Expressions Using the Enumerable Type and Lambda Expressions..... | 467 |
| Building Query Expressions Using the Enumerable Type and Anonymous Methods | 469 |
| Building Query Expressions Using the Enumerable Type and Raw Delegates..... | 469 |
| Summary..... | 471 |
| ■ Chapter 13: Understanding Object Lifetime..... | 473 |
| Classes, Objects, and References | 473 |
| The Basics of Object Lifetime..... | 475 |
| The CIL of new | 475 |
| Setting Object References to null | 477 |

| | |
|--|------------|
| The Role of Application Roots..... | 477 |
| Understanding Object Generations..... | 479 |
| Concurrent Garbage Collection Prior to .NET 4.0..... | 480 |
| Background Garbage Collection Under .NET 4.0 and Beyond | 480 |
| The System.GC Type..... | 481 |
| Forcing a Garbage Collection..... | 482 |
| Building Finalizable Objects | 485 |
| Overriding System.Object.Finalize()..... | 486 |
| Detailing the Finalization Process | 488 |
| Building Disposable Objects..... | 488 |
| Reusing the C# using Keyword..... | 490 |
| Building Finalizable and Disposable Types..... | 492 |
| A Formalized Disposal Pattern | 493 |
| Understanding Lazy Object Instantiation..... | 495 |
| Customizing the Creation of the Lazy Data..... | 498 |
| Summary..... | 499 |
| ■ Part V: Programming with .NET Assemblies..... | 501 |
| ■ Chapter 14: Building and Configuring Class Libraries..... | 503 |
| Defining Custom Namespaces | 503 |
| Resolving Name Clashes with Fully Qualified Names | 505 |
| Resolving Name Clashes with Aliases..... | 507 |
| Creating Nested Namespaces | 508 |
| The Default Namespace of Visual Studio..... | 509 |
| The Role of .NET Assemblies..... | 510 |
| Assemblies Promote Code Reuse..... | 510 |
| Assemblies Establish a Type Boundary | 510 |
| Assemblies are Versionable Units..... | 511 |
| Assemblies are Self-Describing | 511 |
| Assemblies are Configurable..... | 511 |

| | |
|---|------------|
| Understanding the Format of a .NET Assembly | 511 |
| The Windows File Header | 512 |
| The CLR File Header | 513 |
| CIL Code, Type Metadata, and the Assembly Manifest..... | 514 |
| Optional Assembly Resources | 514 |
| Building and Consuming Custom Class Library | 514 |
| Exploring the Manifest..... | 517 |
| Exploring the CIL..... | 520 |
| Exploring the Type Metadata | 521 |
| Building a C# Client Application..... | 522 |
| Building a Visual Basic Client Application..... | 523 |
| Cross-Language Inheritance in Action..... | 525 |
| Understanding Private Assemblies | 526 |
| The Identity of a Private Assembly | 526 |
| Understanding the Probing Process | 526 |
| Configuring Private Assemblies..... | 527 |
| The Role of the App.Config File..... | 529 |
| Understanding Shared Assemblies | 531 |
| The Global Assembly Cache..... | 532 |
| Understanding Strong Names..... | 533 |
| Generating Strong Names at the Command Line | 535 |
| Generating Strong Names Using Visual Studio | 537 |
| Installing Strongly Named Assemblies to the GAC | 539 |
| Consuming a Shared Assembly | 540 |
| Exploring the Manifest of SharedCarLibClient..... | 542 |
| Configuring Shared Assemblies | 542 |
| Freezing the Current Shared Assembly | 543 |
| Building a Shared Assembly Version 2.0.0.0 | 543 |
| Dynamically Redirecting to Specific Versions of a Shared Assembly | 546 |

| | |
|--|------------|
| Understanding Publisher Policy Assemblies | 547 |
| Disabling Publisher Policy | 548 |
| Understanding the <codeBase> Element | 549 |
| The System.Configuration Namespace | 550 |
| The Configuration File Schema Documentation | 552 |
| Summary | 553 |
| ■ Chapter 15: Type Reflection, Late Binding, and Attribute-Based Programming..... | 555 |
| The Necessity of Type Metadata..... | 555 |
| Viewing (Partial) Metadata for the EngineState Enumeration | 556 |
| Viewing (Partial) Metadata for the Car Type | 557 |
| Examining a TypeRef | 559 |
| Documenting the Defining Assembly..... | 559 |
| Documenting Referenced Assemblies..... | 559 |
| Documenting String Literals | 560 |
| Understanding Reflection..... | 561 |
| The System.Type Class..... | 561 |
| Obtaining a Type Reference Using System.Object.GetType()..... | 562 |
| Obtaining a Type Reference Using typeof() | 563 |
| Obtaining a Type Reference Using System.Type.GetType()..... | 563 |
| Building a Custom Metadata Viewer | 564 |
| Reflecting on Methods..... | 564 |
| Reflecting on Fields and Properties..... | 565 |
| Reflecting on Implemented Interfaces..... | 565 |
| Displaying Various Odds and Ends | 566 |
| Implementing Main() | 566 |
| Reflecting on Generic Types | 568 |
| Reflecting on Method Parameters and Return Values | 568 |
| Dynamically Loading Assemblies | 569 |
| Reflecting on Shared Assemblies..... | 572 |

| | |
|---|------------|
| Understanding Late Binding | 574 |
| The System.Activator Class | 574 |
| Invoking Methods with No Parameters..... | 576 |
| Invoking Methods with Parameters..... | 577 |
| Understanding the Role of .NET Attributes | 578 |
| Attribute Consumers..... | 579 |
| Applying Attributes in C# | 579 |
| C# Attribute Shorthand Notation..... | 581 |
| Specifying Constructor Parameters for Attributes..... | 581 |
| The Obsolete Attribute in Action | 581 |
| Building Custom Attributes | 582 |
| Applying Custom Attributes | 583 |
| Named Property Syntax..... | 583 |
| Restricting Attribute Usage..... | 584 |
| Assembly-Level Attributes | 585 |
| The Visual Studio AssemblyInfo.cs File..... | 586 |
| Reflecting on Attributes Using Early Binding | 587 |
| Reflecting on Attributes Using Late Binding | 588 |
| Putting Reflection, Late Binding, and Custom Attributes in Perspective | 590 |
| Building an Extendable Application | 591 |
| Building CommonSnappableTypes.dll | 591 |
| Building the C# Snap-In..... | 592 |
| Building the Visual Basic Snap-In..... | 593 |
| Building an Extendable Windows Forms Application..... | 593 |
| Summary | 598 |
| ■ Chapter 16: Dynamic Types and the Dynamic Language Runtime | 599 |
| The Role of the C# dynamic Keyword | 599 |
| Calling Members on Dynamically Declared Data..... | 601 |
| The Role of the Microsoft.CSharp.dll Assembly..... | 602 |
| The Scope of the dynamic Keyword | 603 |

| | |
|---|------------|
| Limitations of the dynamic Keyword | 604 |
| Practical Uses of the dynamic Keyword | 605 |
| The Role of the Dynamic Language Runtime | 605 |
| The Role of Expression Trees..... | 606 |
| The Role of the System.Dynamic Namespace..... | 606 |
| Dynamic Runtime Lookup of Expression Trees..... | 607 |
| Simplifying Late-Bound Calls Using Dynamic Types | 607 |
| Leveraging the dynamic Keyword to Pass Arguments | 608 |
| Simplifying COM Interoperability Using Dynamic Data..... | 611 |
| The Role of Primary Interop Assemblies | 612 |
| Embedding Interop Metadata | 613 |
| Common COM Interop Pain Points..... | 614 |
| COM Interop Using C# Dynamic Data | 615 |
| COM interop Without C# Dynamic Data | 619 |
| Summary..... | 621 |
| ■ Chapter 17: Processes, AppDomains, and Object Contexts | 623 |
| The Role of a Windows Process | 623 |
| The Role of Threads..... | 624 |
| Interacting with Processes Under the .NET Platform | 626 |
| Enumerating Running Processes..... | 628 |
| Investigating a Specific Process..... | 629 |
| Investigating a Process’s Thread Set..... | 630 |
| Investigating a Process’s Module Set..... | 632 |
| Starting and Stopping Processes Programmatically | 633 |
| Controlling Process Startup Using the ProcessStartInfo Class..... | 634 |
| Understanding .NET Application Domains | 635 |
| The System.AppDomain Class..... | 636 |
| Interacting with the Default Application Domain..... | 638 |
| Enumerating Loaded Assemblies | 639 |
| Receiving Assembly Load Notifications..... | 640 |

| | |
|--|------------|
| Creating New Application Domains | 641 |
| Loading Assemblies into Custom Application Domains | 643 |
| Programmatically Unloading AppDomains | 644 |
| Understanding Object Context Boundaries..... | 645 |
| Context-Agile and Context-Bound Types | 646 |
| Defining a Context-Bound Object | 647 |
| Inspecting an Object's Context | 647 |
| Summarizing Processes, AppDomains, and Context | 649 |
| Summary..... | 649 |
| ■ Chapter 18: Understanding CIL and the Role of Dynamic Assemblies..... | 651 |
| Motivations for Learning the Grammar of CIL | 651 |
| Examining CIL Directives, Attributes, and Opcodes | 652 |
| The Role of CIL Directives..... | 653 |
| The Role of CIL Attributes | 653 |
| The Role of CIL Opcodes..... | 653 |
| The CIL Opcode/CIL Mnemonic Distinction..... | 654 |
| Pushing and Popping: The Stack-Based Nature of CIL..... | 654 |
| Understanding Round-Trip Engineering | 656 |
| The Role of CIL Code Labels | 659 |
| Interacting with CIL: Modifying an *.il File..... | 660 |
| Compiling CIL Code Using ilasm.exe | 661 |
| The Role of peverify.exe | 662 |
| Understanding CIL Directives and Attributes..... | 663 |
| Specifying Externally Referenced Assemblies in CIL..... | 663 |
| Defining the Current Assembly in CIL | 663 |
| Defining Namespaces in CIL..... | 664 |
| Defining Class Types in CIL..... | 665 |
| Defining and Implementing Interfaces in CIL..... | 666 |
| Defining Structures in CIL..... | 667 |
| Defining Enums in CIL..... | 667 |

| | |
|---|------------|
| Defining Generics in CIL | 668 |
| Compiling the CILTypes.il file | 668 |
| .NET Base Class Library, C#, and CIL Data Type Mappings..... | 669 |
| Defining Type Members in CIL..... | 670 |
| Defining Field Data in CIL | 670 |
| Defining Type Constructors in CIL..... | 671 |
| Defining Properties in CIL | 671 |
| Defining Member Parameters..... | 672 |
| Examining CIL Opcodes..... | 673 |
| The .maxstack Directive | 675 |
| Declaring Local Variables in CIL | 675 |
| Mapping Parameters to Local Variables in CIL | 676 |
| The Hidden this Reference | 677 |
| Representing Iteration Constructs in CIL | 677 |
| Building a .NET Assembly with CIL..... | 678 |
| Building CILCars.dll..... | 678 |
| Building CILCarClient.exe | 681 |
| Understanding Dynamic Assemblies | 683 |
| Exploring the System.Reflection.Emit Namespace..... | 683 |
| The Role of the System.Reflection.Emit.ILGenerator | 684 |
| Emitting a Dynamic Assembly | 685 |
| Emitting the Assembly and Module Set..... | 687 |
| The Role of the ModuleBuilder Type | 688 |
| Emitting the HelloClass Type and the String Member Variable..... | 689 |
| Emitting the Constructors..... | 690 |
| Emitting the SayHello() Method..... | 691 |
| Using the Dynamically Generated Assembly | 691 |
| Summary..... | 692 |

■ **Part VI: Introducing the .NET Base Class Libraries..... 693**

■ **Chapter 19: Multithreaded, Parallel, and Async Programming 695**

The Process/AppDomain/Context/Thread Relationship..... 695

 The Problem of Concurrency 696

 The Role of Thread Synchronization 697

A Brief Review of the .NET Delegate 697

The Asynchronous Nature of Delegates 699

 The BeginInvoke() and EndInvoke() Methods..... 700

 The System.IAsyncResult Interface 700

Invoking a Method Asynchronously..... 701

 Synchronizing the Calling Thread 702

 The Role of the AsyncCallback Delegate 703

 The Role of the AsyncResult Class 706

 Passing and Receiving Custom State Data..... 706

The System.Threading Namespace..... 707

The System.Threading.Thread Class 708

 Obtaining Statistics About the Current Thread of Execution..... 709

 The Name Property 710

 The Priority Property..... 711

Manually Creating Secondary Threads..... 711

 Working with the ThreadStart Delegate..... 712

 Working with the ParameterizedThreadStart Delegate 714

 The AutoResetEvent Class 715

 Foreground Threads and Background Threads..... 716

The Issue of Concurrency 717

 Synchronization Using the C# lock Keyword 719

 Synchronization Using the System.Threading.Monitor Type..... 722

 Synchronization Using the System.Threading.Interlocked Type 722

 Synchronization Using the [Synchronization] Attribute 724

| | |
|---|------------|
| Programming with Timer Callbacks | 724 |
| Understanding the CLR ThreadPool | 726 |
| Parallel Programming Using the Task Parallel Library | 727 |
| The System.Threading.Tasks Namespace | 728 |
| The Role of the Parallel Class | 728 |
| Data Parallelism with the Parallel Class | 729 |
| Accessing UI Elements on Secondary Threads | 731 |
| The Task Class | 732 |
| Handling Cancellation Request | 733 |
| Task Parallelism Using the Parallel Class | 735 |
| Parallel LINQ Queries (PLINQ) | 738 |
| Opting in to a PLINQ Query | 739 |
| Cancelling a PLINQ Query | 740 |
| Asynchronous Calls with the async Keyword | 741 |
| A First Look at the C# async and await Keywords | 741 |
| Naming Conventions for Async Methods | 743 |
| Async Methods Returning Void | 744 |
| Async Methods with Multiple Awaits | 744 |
| Retrofitting the AddWithThreads Example Using Async/Await | 745 |
| Summary | 747 |
| ■ Chapter 20: File I/O and Object Serialization | 749 |
| Exploring the System.IO Namespace | 749 |
| The Directory(Info) and File(Info) Types | 750 |
| The Abstract FileSystemInfo Base Class | 751 |
| Working with the DirectoryInfo Type | 752 |
| Enumerating Files with the DirectoryInfo Type | 753 |
| Creating Subdirectories with the DirectoryInfo Type | 754 |
| Working with the Directory Type | 756 |
| Working with the DriveInfo Class Type | 757 |

| | |
|--|------------|
| Working with the FileInfo Class | 758 |
| The FileInfo.Create() Method | 759 |
| The FileInfo.Open() Method | 759 |
| The FileInfo.OpenRead() and FileInfo.OpenWrite() Methods | 761 |
| The FileInfo.OpenText() Method..... | 761 |
| The FileInfo.CreateText() and FileInfo.AppendText() Methods..... | 762 |
| Working with the File Type | 762 |
| Additional File-Centric Members | 763 |
| The Abstract Stream Class | 764 |
| Working with FileStreams | 765 |
| Working with StreamWriters and StreamReaders | 767 |
| Writing to a Text File | 768 |
| Reading from a Text File | 769 |
| Directly Creating StreamWriter/StreamReader Types..... | 770 |
| Working with StringWriters and StringReaders | 770 |
| Working with BinaryWriters and BinaryReaders | 772 |
| Watching Files Programmatically | 774 |
| Understanding Object Serialization | 776 |
| The Role of Object Graphs | 778 |
| Configuring Objects for Serialization | 779 |
| Defining Serializable Types..... | 779 |
| Public Fields, Private Fields, and Public Properties | 780 |
| Choosing a Serialization Formatter | 781 |
| The IFormatter and IRemotingFormatter Interfaces | 781 |
| Type Fidelity Among the Formatters | 782 |
| Serializing Objects Using the BinaryFormatter | 783 |
| Deserializing Objects Using the BinaryFormatter | 785 |
| Serializing Objects Using the SoapFormatter | 786 |
| Serializing Objects Using the XmlSerializer | 787 |
| Controlling the Generated XML Data | 788 |

| | |
|--|------------|
| Serializing Collections of Objects | 790 |
| Customizing the Soap/Binary Serialization Process..... | 791 |
| A Deeper Look at Object Serialization | 792 |
| Customizing Serialization Using ISerializable..... | 793 |
| Customizing Serialization Using Attributes..... | 796 |
| Summary..... | 797 |
| ■ Chapter 21: ADO.NET Part I: The Connected Layer..... | 799 |
| A High-Level Definition of ADO.NET | 800 |
| The Three Faces of ADO.NET | 801 |
| Understanding ADO.NET Data Providers..... | 802 |
| The Microsoft-Supplied ADO.NET Data Providers | 804 |
| A Word Regarding System.Data.OracleClient.dll..... | 805 |
| Obtaining Third-Party ADO.NET Data Providers | 805 |
| Additional ADO.NET Namespaces | 806 |
| The Types of the System.Data Namespace | 806 |
| The Role of the IDbConnection Interface | 807 |
| The Role of the IDbTransaction Interface..... | 808 |
| The Role of the IDbCommand Interface..... | 808 |
| The Role of the IDbDataParameter and IDataParameter Interfaces | 809 |
| The Role of the IDbDataAdapter and IDataAdapter Interfaces..... | 809 |
| The Role of the IDataReader and IDataRecord Interfaces | 810 |
| Abstracting Data Providers Using Interfaces..... | 811 |
| Increasing Flexibility Using Application Configuration Files | 813 |
| Creating the AutoLot Database..... | 814 |
| Creating the Inventory Table..... | 815 |
| Adding Test Records to the Inventory Table..... | 818 |
| Authoring the GetPetName() Stored Procedure..... | 819 |
| Creating the Customers and Orders Tables | 820 |
| Creating Table Relationships in Visual Studio..... | 822 |

| | |
|---|------------|
| The ADO.NET Data Provider Factory Model | 823 |
| A Complete Data Provider Factory Example | 824 |
| A Potential Drawback with the Data Provider Factory Model | 827 |
| The <connectionStrings> Element..... | 828 |
| Understanding the Connected Layer of ADO.NET | 829 |
| Working with Connection Objects..... | 830 |
| Working with ConnectionStringBuilder Objects..... | 833 |
| Working with Command Objects | 834 |
| Working with Data Readers..... | 835 |
| Obtaining Multiple Result Sets Using a Data Reader..... | 836 |
| Building a Reusable Data Access Library..... | 837 |
| Adding the Connection Logic..... | 838 |
| Adding the Insertion Logic..... | 839 |
| Adding the Deletion Logic..... | 840 |
| Adding the Update Logic..... | 841 |
| Adding the Selection Logic | 841 |
| Working with Parameterized Command Objects | 842 |
| Specifying Parameters Using the DbParameter Type | 843 |
| Executing a Stored Procedure | 844 |
| Creating a Console UI–Based Front End..... | 846 |
| Implementing the Main() Method..... | 847 |
| Implementing the ShowInstructions() Method | 849 |
| Implementing the ListInventory() Method..... | 849 |
| Implementing the DeleteCar() Method | 850 |
| Implementing the InsertNewCar() Method | 850 |
| Implementing the UpdateCarPetName() Method..... | 851 |
| Implementing LookUpPetName()..... | 851 |
| Understanding Database Transactions..... | 852 |
| Key Members of an ADO.NET Transaction Object | 853 |
| Adding a CreditRisks Table to the AutoLot Database..... | 854 |

| | |
|---|------------|
| Adding a Transaction Method to InventoryDAL..... | 855 |
| Testing Your Database Transaction..... | 857 |
| Summary..... | 858 |
| ■ Chapter 22: ADO.NET Part II: The Disconnected Layer..... | 859 |
| Understanding the Disconnected Layer of ADO.NET..... | 860 |
| Understanding the Role of the DataSet..... | 861 |
| Key Properties of the DataSet..... | 861 |
| Key Methods of the DataSet..... | 862 |
| Building a DataSet..... | 863 |
| Working with DataColumnns..... | 863 |
| Building a DataColumn..... | 864 |
| Enabling Autoincrementing Fields..... | 865 |
| Adding DataColumn Objects to a DataTable..... | 866 |
| Working with DataRows..... | 866 |
| Understanding the RowState Property..... | 868 |
| Understanding the DataRowVersion Property..... | 869 |
| Working with DataTables..... | 870 |
| Inserting DataTables into DataSets..... | 871 |
| Obtaining Data in a DataSet..... | 872 |
| Processing DataTable Data Using DataTableReader Objects..... | 873 |
| Serializing DataTable/DataSet Objects As XML..... | 874 |
| Serializing DataTable/DataSet Objects in a Binary Format..... | 876 |
| Binding DataTable Objects to Windows Forms GUIs..... | 877 |
| Hydrating a DataTable from a Generic List<T>..... | 878 |
| Deleting Rows from a DataTable..... | 881 |
| Selecting Rows Based on Filter Criteria..... | 882 |
| Updating Rows Within a DataTable..... | 885 |
| Working with the DataView Type..... | 885 |

| | |
|---|------------|
| Working with Data Adapters..... | 888 |
| A Simple Data Adapter Example | 888 |
| Mapping Database Names to Friendly Names..... | 890 |
| Adding Disconnected Functionality to AutoLotDAL.dll..... | 891 |
| Defining the Initial Class Type..... | 892 |
| Configuring the Data Adapter Using the SqlCommandBuilder..... | 892 |
| Implementing GetAllInventory()..... | 894 |
| Implementing UpdateInventory()..... | 894 |
| Setting Your Version Number | 894 |
| Testing the Disconnected Functionality..... | 894 |
| Multitabled DataSet Objects and Data Relationships | 896 |
| Prepping the Data Adapters..... | 897 |
| Building the Table Relationships..... | 899 |
| Updating the Database Tables | 899 |
| Navigating Between Related Tables | 900 |
| The Windows Forms Database Designer Tools..... | 902 |
| Visually Designing the DataGridView..... | 902 |
| The Generated App.config File..... | 909 |
| Examining the Strongly Typed DataSet..... | 909 |
| Examining the Strongly Typed DataTable..... | 911 |
| Examining the Strongly Typed DataRow | 912 |
| Examining the Strongly Typed Data Adapter..... | 913 |
| Completing the Windows Forms Application | 914 |
| Isolating Strongly Typed Database Code into a Class Library..... | 915 |
| Viewing the Generated Code | 916 |
| Selecting Data with the Generated Code..... | 918 |
| Inserting Data with the Generated Code..... | 919 |
| Deleting Data with the Generated Code..... | 920 |
| Invoking a Stored Procedure Using the Generated Code..... | 921 |

| | |
|---|------------|
| Programming with LINQ to DataSet | 921 |
| The Role of the DataSet Extensions Library | 923 |
| Obtaining a LINQ-Compatible DataTable..... | 924 |
| The Role of the DataRowExtensions.Field<T>() Extension Method | 926 |
| Hydrating New DataTables from LINQ Queries | 927 |
| Summary..... | 928 |
| ■ Chapter 23: ADO.NET Part III: Entity Framework | 929 |
| Understanding the Role of the Entity Framework | 930 |
| The Role of Entities..... | 932 |
| The Building Blocks of the Entity Framework..... | 934 |
| Code First from an Existing Database | 938 |
| Generating the Model | 938 |
| What Did That Do? | 942 |
| Changing the Default Mappings | 945 |
| Adding to the Generated Model Classes..... | 946 |
| Using the Model Classes in Code | 947 |
| Inserting a Record | 947 |
| Selecting Records..... | 948 |
| The Role of Navigation Properties | 951 |
| Deleting a Record | 954 |
| Updating a Record | 955 |
| Handling Database Changes | 956 |
| AutoLotDAL Version 4 | 956 |
| Entity Framework Data Annotations | 957 |
| Adding or Updating the Model Classes..... | 958 |
| Adding the DbContext..... | 964 |
| Adding the Repositories..... | 966 |
| Initializing the Database | 975 |

| | |
|--|------------|
| Test-Driving AutoLotDAL | 976 |
| Printing All Inventory Records | 977 |
| Adding Inventory Records..... | 977 |
| Editing Records..... | 978 |
| Using Navigation Properties | 979 |
| Multitable Actions/Implicit Transactions | 980 |
| Entity Framework Migrations | 982 |
| Updating the Model | 982 |
| Testing the App | 984 |
| Entering EF Migrations | 985 |
| Creating the Baseline Migration | 985 |
| Seeding the Database..... | 989 |
| Revisiting the Transaction Test | 990 |
| Concurrency | 991 |
| Correcting the Repositories | 992 |
| Testing Concurrency | 992 |
| Interception | 993 |
| The IDbCommandInterceptor Interface..... | 993 |
| Adding Interception to AutoLotDAL..... | 994 |
| Registering the Interceptor..... | 995 |
| Adding the DatabaseLogger Interceptor..... | 995 |
| ObjectMaterialized and SavingChanges Events | 996 |
| Accessing the Object Context..... | 996 |
| ObjectMaterialized..... | 996 |
| SavingChanges | 997 |
| Deploying to SQL Server | 998 |
| Summary | 999 |

| | |
|---|-------------|
| ■ Chapter 24: Introducing LINQ to XML | 1001 |
| A Tale of Two XML APIs..... | 1001 |
| LINQ to XML As a Better DOM..... | 1003 |
| VB Literal Syntax As a Better LINQ to XML..... | 1004 |
| Members of the System.Xml.Linq Namespace | 1005 |
| The LINQ to XML Axis Methods..... | 1008 |
| The Oddness of XName (and XNamespace) | 1009 |
| Working with XElement and XDocument..... | 1010 |
| Generating Documents from Arrays and Containers | 1012 |
| Loading and Parsing XML Content..... | 1014 |
| Manipulating an In-Memory XML Document..... | 1014 |
| Building the UI of the LINQ to XML App..... | 1014 |
| Import the Inventory.xml File | 1015 |
| Defining a LINQ to XML Helper Class..... | 1016 |
| Attaching the UI to Your Helper Class | 1017 |
| Summary..... | 1019 |
| ■ Chapter 25: Introducing Windows Communication Foundation | 1021 |
| A Potpourri of Distributed Computing APIs..... | 1021 |
| The Role of DCOM..... | 1022 |
| The Role of COM+/Enterprise Services | 1023 |
| The Role of MSMQ | 1023 |
| The Role of .NET Remoting..... | 1024 |
| The Role of XML Web Services | 1024 |
| Web Service Standards | 1025 |
| The Role of WCF | 1026 |
| An Overview of WCF Features | 1026 |
| An Overview of Service-Oriented Architecture | 1027 |
| Tenet 1: Boundaries are Explicit | 1027 |
| Tenet 2: Services are Autonomous | 1027 |
| Tenet 3: Services Communicate via Contract, Not Implementation..... | 1027 |

| | |
|--|-------------|
| Tenet 4: Service Compatibility is Based on Policy | 1027 |
| WCF: The Bottom Line..... | 1028 |
| Investigating the Core WCF Assemblies | 1028 |
| The Visual Studio WCF Project Templates | 1029 |
| The WCF Service Web Site Project Template | 1030 |
| The Basic Composition of a WCF Application | 1031 |
| The ABCs of WCF | 1032 |
| Understanding WCF Contracts | 1033 |
| Understanding WCF Bindings | 1034 |
| HTTP-Based Bindings | 1034 |
| TCP-Based Bindings | 1035 |
| MSMQ-Based Bindings..... | 1036 |
| Understanding WCF Addresses..... | 1037 |
| Building a WCF Service | 1038 |
| The [ServiceContract] Attribute | 1039 |
| The [OperationContract] Attribute..... | 1040 |
| Service Types As Operational Contracts | 1040 |
| Hosting the WCF Service | 1041 |
| Establishing the ABCs Within an App.config File | 1042 |
| Coding Against the ServiceHost Type | 1043 |
| Specifying Base Addresses | 1043 |
| Details of the ServiceHost Type | 1045 |
| Details of the <system.serviceModel> Element..... | 1046 |
| Enabling Metadata Exchange | 1047 |
| Building the WCF Client Application | 1050 |
| Generating Proxy Code Using svcutil.exe | 1050 |
| Generating Proxy Code Using Visual Studio..... | 1051 |
| Configuring a TCP-Based Binding..... | 1053 |
| Simplifying Configuration Settings..... | 1055 |
| Leveraging Default Endpoints..... | 1055 |
| Exposing a Single WCF Service Using Multiple Bindings..... | 1056 |

| | |
|--|-------------|
| Changing Settings for a WCF Binding..... | 1058 |
| Leveraging the Default MEX Behavior Configuration..... | 1059 |
| Refreshing the Client Proxy and Selecting the Binding | 1060 |
| Using the WCF Service Library Project Template | 1062 |
| Building a Simple Math Service | 1063 |
| Testing the WCF Service with WcfTestClient.exe | 1063 |
| Altering Configuration Files Using SvcConfigEditor.exe..... | 1064 |
| Hosting the WCF Service Within a Windows Service..... | 1066 |
| Specifying the ABCs in Code..... | 1067 |
| Enabling MEX..... | 1069 |
| Creating a Windows Service Installer | 1069 |
| Installing the Windows Service..... | 1071 |
| Invoking a Service Asynchronously from the Client | 1072 |
| Designing WCF Data Contracts..... | 1075 |
| Using the Web-centric WCF Service Project Template..... | 1076 |
| Implementing the Service Contract | 1078 |
| The Role of the *.svc File..... | 1079 |
| Examining the Web.config File..... | 1079 |
| Testing the Service | 1080 |
| Summary..... | 1081 |
| ■ Part VII: Windows Presentation Foundation | 1083 |
| ■ Chapter 26: Introducing Windows Presentation Foundation and XAML..... | 1085 |
| The Motivation Behind WPF..... | 1085 |
| Unifying Diverse APIs..... | 1086 |
| Providing a Separation of Concerns via XAML..... | 1086 |
| Providing an Optimized Rendering Model | 1087 |
| Simplifying Complex UI Programming | 1088 |
| The Various Flavors of WPF | 1088 |
| Traditional Desktop Applications | 1088 |
| Navigation-Based WPF Applications..... | 1090 |

| | |
|---|-------------|
| XBAP Applications..... | 1091 |
| The WPF/Silverlight Relationship..... | 1093 |
| Investigating the WPF Assemblies..... | 1093 |
| The Role of the Application Class | 1095 |
| Constructing an Application Class | 1095 |
| Enumerating the Windows Collection | 1096 |
| The Role of the Window Class | 1096 |
| Building a WPF Application Without XAML | 1100 |
| Creating a Strongly Typed Window | 1102 |
| Creating a Simple User Interface..... | 1103 |
| Interacting with Application-Level Data..... | 1104 |
| Handling the Closing of a Window Object..... | 1105 |
| Intercepting Mouse Events | 1107 |
| Intercepting Keyboard Events..... | 1108 |
| Building a WPF Application Using Only XAML..... | 1109 |
| Defining a Window Object in XAML..... | 1110 |
| Defining the Application Object in XAML | 1111 |
| Processing the XAML Files Using msbuild.exe | 1112 |
| Transforming Markup into a .NET Assembly | 1114 |
| Mapping the Window XAML Markup to C# Code | 1114 |
| The Role of BAML | 1115 |
| Mapping the Application XAML Markup to C# Code | 1116 |
| XAML-to-Assembly Process Summary | 1117 |
| Understanding the Syntax of WPF XAML..... | 1118 |
| Introducing Kaxaml..... | 1118 |
| XAML XML Namespaces and XAML “Keywords” | 1119 |
| Controlling Class and Member Variable Visibility..... | 1122 |
| XAML Elements, XAML Attributes, and Type Converters | 1122 |
| Understanding XAML Property-Element Syntax | 1123 |
| Understanding XAML Attached Properties..... | 1124 |
| Understanding XAML Markup Extensions..... | 1125 |

| | |
|--|-------------|
| Building a WPF Application Using Code-Behind Files..... | 1127 |
| Adding a Code File for the MainWindow Class | 1127 |
| Adding a Code File for the MyApp Class..... | 1128 |
| Processing the Code Files with msbuild.exe | 1129 |
| Building WPF Applications Using Visual Studio | 1130 |
| The WPF Project Templates | 1130 |
| The Toolbox and XAML Designer/Editor | 1132 |
| Setting Properties Using the Properties Window..... | 1134 |
| Handling Events Using the Properties Window..... | 1136 |
| Handling Events in the XAML Editor | 1137 |
| The Document Outline Window..... | 1137 |
| Viewing the Autogenerated Code Files | 1138 |
| Building a Custom XAML Editor with Visual Studio | 1140 |
| Designing the GUI of Your Window..... | 1140 |
| Implementing the Loaded Event | 1142 |
| Implementing the Button’s Click Event..... | 1143 |
| Implementing the Closed Event..... | 1144 |
| Testing Your Application..... | 1144 |
| Exploring the WPF Documentation | 1146 |
| Summary..... | 1146 |
| ■ Chapter 27: Programming with WPF Controls..... | 1147 |
| A Survey of the Core WPF Controls | 1147 |
| The WPF Ink Controls..... | 1148 |
| The WPF Document Controls | 1148 |
| WPF Common Dialog Boxes..... | 1149 |
| The Details Are in the Documentation | 1149 |
| A Brief Review of the Visual Studio WPF Designer | 1150 |
| Working with WPF Controls Using Visual Studio..... | 1151 |
| Working with the Document Outline Editor..... | 1152 |

| | |
|---|-------------|
| Controlling Content Layout Using Panels | 1152 |
| Positioning Content Within Canvas Panels | 1155 |
| Positioning Content Within WrapPanel Panels | 1156 |
| Positioning Content Within StackPanel Panels | 1158 |
| Positioning Content Within Grid Panels | 1159 |
| Grids with GridSplitter Types | 1161 |
| Positioning Content Within DockPanel Panels | 1162 |
| Enabling Scrolling for Panel Types | 1163 |
| Configuring Panels Using the Visual Studio Designers | 1164 |
| Building a Window's Frame Using Nested Panels | 1168 |
| Building the Menu System | 1170 |
| Building Menus Visually | 1171 |
| Building the ToolBar | 1172 |
| Building the StatusBar | 1173 |
| Finalizing the UI Design | 1173 |
| Implementing the MouseEnter/MouseLeave Event Handlers | 1174 |
| Implementing the Spell Checking Logic | 1175 |
| Understanding WPF Commands | 1175 |
| The Intrinsic Command Objects | 1176 |
| Connecting Commands to the Command Property | 1177 |
| Connecting Commands to Arbitrary Actions | 1178 |
| Working with the Open and Save Commands | 1180 |
| Understanding Routed Events | 1182 |
| The Role of Routed Bubbling Events | 1183 |
| Continuing or Halting Bubbling | 1184 |
| The Role of Routed Tunneling Events | 1184 |
| A Deeper Look at WPF APIs and Controls | 1186 |
| Working with the TabControl | 1186 |
| Building the Ink API Tab | 1189 |
| Designing the ToolBar | 1190 |
| The RadioButton Control | 1193 |

| | |
|---|-------------|
| Handling Events for the Ink API Tab | 1194 |
| The InkCanvas Control | 1195 |
| The ComboBox Control | 1198 |
| Saving, Loading, and Clearing InkCanvas Data..... | 1200 |
| Introducing the Documents API | 1201 |
| Block Elements and Inline Elements | 1201 |
| Document Layout Managers..... | 1201 |
| Building the Documents Tab..... | 1202 |
| Populating a FlowDocument Using Code..... | 1203 |
| Enabling Annotations and Sticky Notes | 1205 |
| Saving and Loading a Flow Document | 1207 |
| Introducing the WPF Data-Binding Model | 1208 |
| Building the Data Binding Tab..... | 1209 |
| Establishing Data Bindings Using Visual Studio | 1209 |
| The DataContext Property..... | 1212 |
| Data Conversion Using IValueConverter | 1213 |
| Establishing Data Bindings in Code | 1214 |
| Building the DataGrid Tab | 1215 |
| Understanding the Role of Dependency Properties..... | 1217 |
| Examining an Existing Dependency Property | 1218 |
| Important Notes Regarding CLR Property Wrappers..... | 1221 |
| Building a Custom Dependency Property | 1222 |
| Adding a Data Validation Routine | 1225 |
| Responding to the Property Change | 1226 |
| Summary..... | 1227 |

| | |
|--|-------------|
| ■ Chapter 28: WPF Graphics Rendering Services | 1229 |
| Understanding WPF's Graphical Rendering Services | 1229 |
| WPF Graphical Rendering Options..... | 1230 |
| Rendering Graphical Data Using Shapes..... | 1231 |
| Adding Rectangles, Ellipses, and Lines to a Canvas..... | 1233 |
| Removing Rectangles, Ellipses, and Lines from a Canvas..... | 1236 |
| Working with Polylines and Polygons..... | 1238 |
| Working with Paths..... | 1239 |
| WPF Brushes and Pens | 1243 |
| Configuring Brushes Using Visual Studio..... | 1243 |
| Configuring Brushes in Code | 1247 |
| Configuring Pens | 1248 |
| Applying Graphical Transformations..... | 1249 |
| A First Look at Transformations..... | 1250 |
| Transforming Your Canvas Data..... | 1251 |
| Working with the Visual Studio Transform Editor | 1253 |
| Building the Initial Layout..... | 1254 |
| Applying Transformations at Design Time | 1256 |
| Transforming the Canvas in Code..... | 1257 |
| Rendering Graphical Data Using Drawings and Geometries | 1258 |
| Building a DrawingBrush Using Geometries..... | 1259 |
| Painting with the DrawingBrush..... | 1260 |
| Containing Drawing Types in a DrawingImage | 1261 |
| Working with Vector Images..... | 1262 |
| Converting a Sample Vector Graphic File into XAML | 1262 |
| Importing the Graphical Data into a WPF Project..... | 1265 |
| Interacting with the Sign | 1266 |
| Rendering Graphical Data Using the Visual Layer | 1267 |
| The Visual Base Class and Derived Child Classes | 1268 |
| A First Look at Using the DrawingVisual Class | 1269 |

| | |
|--|-------------|
| Rendering Visual Data to a Custom Layout Manager..... | 1271 |
| Responding to Hit-Test Operations..... | 1273 |
| Summary..... | 1275 |
| ■ Chapter 29: WPF Resources, Animations, Styles, and Templates..... | 1277 |
| Understanding the WPF Resource System..... | 1277 |
| Working with Binary Resources..... | 1277 |
| Working with Object (Logical) Resources..... | 1285 |
| The Role of the Resources Property..... | 1285 |
| Defining Window-Wide Resources..... | 1285 |
| The {StaticResource} Markup Extension..... | 1289 |
| The {DynamicResource} Markup Extension..... | 1289 |
| Application-Level Resources..... | 1290 |
| Defining Merged Resource Dictionaries..... | 1292 |
| Defining a Resource-Only Assembly..... | 1294 |
| Understanding WPF's Animation Services..... | 1296 |
| The Role of the Animation Class Types..... | 1296 |
| The To, From, and By Properties..... | 1297 |
| The Role of the Timeline Base Class..... | 1297 |
| Authoring an Animation in C# Code..... | 1298 |
| Controlling the Pace of an Animation..... | 1300 |
| Reversing and Looping an Animation..... | 1300 |
| Authoring Animations in XAML..... | 1301 |
| The Role of Storyboards..... | 1302 |
| The Role of Event Triggers..... | 1303 |
| Animation Using Discrete Key Frames..... | 1303 |
| Understanding the Role of WPF Styles..... | 1304 |
| Defining and Applying a Style..... | 1305 |
| Overriding Style Settings..... | 1306 |
| Limiting Application of a Style with TargetType..... | 1306 |
| Automatically Applying a Style with TargetType..... | 1307 |

| | |
|--|-------------|
| Subclassing Existing Styles..... | 1308 |
| Defining Styles with Triggers..... | 1308 |
| Defining Styles with Multiple Triggers..... | 1309 |
| Animated Styles..... | 1310 |
| Assigning Styles Programmatically..... | 1310 |
| Logical Trees, Visual Trees, and Default Templates | 1312 |
| Programmatically Inspecting a Logical Tree..... | 1313 |
| Programmatically Inspecting a Visual Tree..... | 1314 |
| Programmatically Inspecting a Control's Default Template..... | 1316 |
| Building a Control Template with the Trigger Framework | 1319 |
| Templates as Resources..... | 1321 |
| Incorporating Visual Cues Using Triggers | 1322 |
| The Role of the {TemplateBinding} Markup Extension..... | 1323 |
| The Role of ContentPresenter..... | 1324 |
| Incorporating Templates into Styles | 1325 |
| Summary..... | 1326 |
| ■ Chapter 30: Notifications, Commands, Validation, and MVVM | 1329 |
| Introducing Model-View-ViewModel | 1330 |
| Model..... | 1330 |
| View..... | 1330 |
| ViewModel..... | 1331 |
| Anemic Models or ViewModels..... | 1331 |
| The WPF Binding Notification System | 1331 |
| Observable Models and Collections..... | 1332 |
| Adding Bindings and Data | 1333 |
| Programmatically Changing the Vehicle Data..... | 1335 |
| Observable Models | 1336 |
| Observable Collections | 1339 |

| | |
|--|-------------|
| Validation | 1348 |
| Updating the Sample for the Validation Examples..... | 1348 |
| The Validation Class..... | 1349 |
| Validation Options..... | 1350 |
| Using Data Annotations | 1363 |
| Adding Data Annotations | 1363 |
| Checking for Data Annotation-Based Validation Errors | 1363 |
| Customizing the ErrorTemplate | 1365 |
| Creating Custom Commands | 1367 |
| Implementing the ICommand Interface | 1367 |
| Updating MainWindow.xaml.cs..... | 1368 |
| Updating MainWindow.xaml | 1369 |
| Attaching Command to the CommandManager..... | 1369 |
| Testing the Application | 1370 |
| Adding the Remaining Commands | 1372 |
| Fully Implementing MVVM | 1374 |
| Moving the Data Source Out of the View | 1374 |
| Moving the Commands to the ViewModel | 1375 |
| Updating AutoLotDAL for MVVM | 1376 |
| Updating the AutoLotDAL Models | 1376 |
| Full MVVM Example | 1379 |
| Using ObjectMaterialized with Entity Framework..... | 1380 |
| Summary | 1381 |
| ■ Part VIII: ASP.NET | 1383 |
| ■ Chapter 31: Introducing ASP.NET Web Forms | 1385 |
| The Role of HTTP | 1385 |
| The HTTP Request/Response Cycle | 1385 |
| HTTP Is a Stateless Protocol | 1386 |

| | |
|---|-------------|
| Understanding Web Applications and Web Servers | 1386 |
| The Role of IIS Virtual Directories | 1387 |
| IIS Express | 1387 |
| The Role of HTML | 1388 |
| HTML Document Structure | 1388 |
| The Role of an HTML Form | 1390 |
| The Visual Studio HTML Designer Tools..... | 1390 |
| Building an HTML Form | 1394 |
| The Role of Client-Side Scripting | 1395 |
| A Client-Side Scripting Example..... | 1396 |
| Posting Back to the Web Server | 1397 |
| Postbacks Under Web Forms..... | 1398 |
| An Overview of the Web Forms API | 1398 |
| Major Features of Web Forms 2.0 and Higher | 1399 |
| Major Features of Web Forms 3.5 (and .NET 3.5 SP1) and Higher | 1400 |
| Major Features of Web Forms 4.0..... | 1401 |
| Major Features of Web Forms 4.5 and 4.6..... | 1401 |
| Building a Single-File Web Forms Web App | 1402 |
| Referencing AutoLotDAL.dll | 1404 |
| Designing the UI | 1406 |
| Adding the Data Access Logic | 1406 |
| The Role of ASP.NET Directives..... | 1409 |
| Analyzing the “Script” Block..... | 1410 |
| Analyzing the ASP.NET Control Declarations..... | 1410 |
| Building an ASP.NET Web Page Using Code Files | 1411 |
| Reference the AutoLotDAL Project..... | 1413 |
| Updating the Code File | 1413 |
| Debugging and Tracing ASP.NET Pages | 1415 |
| ASP.NET Web Sites vs. ASP.NET Web Applications | 1416 |
| Enabling C# 6 For ASP.NET Web Sites..... | 1417 |

| | |
|---|-------------|
| The ASP.NET Web Site Directory Structure | 1417 |
| Referencing Assemblies | 1418 |
| The Role of the App_Code Folder | 1419 |
| The Inheritance Chain of the Page Type | 1419 |
| Interacting with the Incoming HTTP Request | 1421 |
| Obtaining Browser Statistics | 1422 |
| Access to Incoming Form Data | 1425 |
| The IsPostBack Property | 1426 |
| Interacting with the Outgoing HTTP Response | 1426 |
| Emitting HTML Content | 1427 |
| Redirecting Users | 1427 |
| The Life Cycle of an ASP.NET Web Page | 1428 |
| The Role of the AutoEventWireup Attribute | 1430 |
| The Error Event | 1430 |
| The Role of the Web.config File | 1431 |
| The ASP.NET Web Site Administration Utility | 1432 |
| Summary | 1433 |
| ■ Chapter 32: ASP.NET Web Controls, Master Pages, and Themes | 1435 |
| Understanding the Nature of Web Controls | 1435 |
| Understanding Server-Side Event Handling | 1436 |
| The AutoPostBack Property | 1437 |
| The Control and WebControl Base Classes | 1438 |
| Enumerating Contained Controls | 1438 |
| Dynamically Adding and Removing Controls | 1442 |
| Interacting with Dynamically Created Controls | 1442 |
| Functionality of the WebControl Base Class | 1443 |
| Major Categories of Web Forms Controls | 1444 |
| A Brief Word Regarding System.Web.UI.HtmlControls | 1448 |
| Web Control Documentation | 1448 |

| | |
|--|-------------|
| Building the Web Forms Cars Web Site | 1449 |
| Working with Web Forms Master Pages..... | 1449 |
| Configuring the TreeView Control Site Navigation Logic..... | 1453 |
| Establishing Breadcrumbs with the SiteMapPath Type | 1455 |
| Configuring the AdRotator Control..... | 1455 |
| Defining the Default Content Page | 1456 |
| Designing the Inventory Content Page | 1459 |
| Adding AutoLotDAL and Entity Framework to AspNetCarsSite | 1459 |
| Filling the GridView with Data | 1460 |
| Enabling In-Place Editing..... | 1461 |
| Enabling Sorting and Paging | 1464 |
| Enabling Filtering..... | 1465 |
| Designing the Build-a-Car Content Page..... | 1467 |
| The Role of the Validation Controls | 1470 |
| Enabling Client-Side JavaScript Validation Support | 1472 |
| The RequiredFieldValidator..... | 1472 |
| The RegularExpressionValidator | 1472 |
| The RangeValidator..... | 1473 |
| The CompareValidator | 1473 |
| Creating Validation Summaries | 1474 |
| Defining Validation Groups..... | 1476 |
| Validation with Data Annotations..... | 1477 |
| Working with Themes..... | 1482 |
| Understanding *.skin Files..... | 1482 |
| Applying Site-Wide Themes..... | 1485 |
| Applying Themes at the Page Level..... | 1485 |
| The SkinID Property..... | 1486 |
| Assigning Themes Programmatically | 1486 |
| Summary..... | 1489 |

| | |
|--|-------------|
| ■ Chapter 33: ASP.NET State Management Techniques | 1491 |
| The Issue of State..... | 1491 |
| ASP.NET State Management Techniques | 1494 |
| Understanding the Role of ASP.NET View State..... | 1494 |
| Demonstrating View State | 1494 |
| Adding Custom View State Data | 1496 |
| The Role of the Global.asax File | 1497 |
| The Global Last-Chance Exception Event Handler..... | 1499 |
| The HttpApplication Base Class..... | 1500 |
| Understanding the Application/Session Distinction | 1500 |
| Maintaining Application-Level State Data..... | 1501 |
| Modifying Application Data..... | 1503 |
| Handling Web Application Shutdown..... | 1504 |
| Working with the Application Cache..... | 1505 |
| Fun with Data Caching | 1505 |
| Modifying the *.aspx File..... | 1508 |
| Maintaining Session Data..... | 1510 |
| Additional Members of HttpSessionState..... | 1513 |
| Understanding Cookies | 1514 |
| Creating Cookies..... | 1514 |
| Reading Incoming Cookie Data..... | 1516 |
| The Role of the <sessionState> Element..... | 1517 |
| Storing Session Data in the ASP.NET Session State Server..... | 1517 |
| Storing Session Data in a Dedicated Database | 1518 |
| Introducing the ASP.NET Profile API..... | 1519 |
| The ASPNETDB.mdf Database | 1519 |
| Defining a User Profile Within web.config | 1520 |
| Accessing Profile Data Programmatically..... | 1522 |
| Grouping Profile Data and Persisting Custom Objects..... | 1524 |
| Summary..... | 1525 |

- **Chapter 34: ASP.NET MVC and Web API** **1527**
- Introducing the MVC Pattern 1527
 - The Model 1527
 - The View 1528
 - The Controller 1528
 - Why MVC? 1528
 - Enter ASP.NET MVC 1529
- Building Your First ASP.NET MVC Application** **1529**
 - The New Project Wizard 1529
 - The Components of a Base MVC Project 1533
 - Updating NuGet Packages to Current Versions 1539
 - Test-Drive Your Site 1540
- Routing** **1542**
 - URL Patterns 1542
 - Creating Routes for the Contact and About Pages 1543
 - Redirecting Users Using Routing 1544
- Adding AutoLotDAL** **1545**
- Controllers and Actions** **1546**
 - Adding the Inventory Controller 1546
 - Examine the Scaffolded Views 1548
 - MVC Controllers 1549
- MVC Views** **1558**
 - The Razor View Engine 1558
 - Layouts 1561
 - Partial Views 1563
 - Sending Data to the View 1564
 - The Index View 1565
 - The Details View 1570

| | |
|--|-------------|
| The Create View | 1571 |
| The Delete View | 1574 |
| The Edit View | 1576 |
| Validation | 1578 |
| Finishing the UI | 1580 |
| The Final Word on ASP.NET MVC | 1582 |
| Introducing ASP.NET Web API | 1583 |
| Adding the Web API Project | 1583 |
| Examining the Web API Project | 1585 |
| Configuring the Project | 1585 |
| A Note About JSON | 1586 |
| Adding a Controller | 1587 |
| Updating CarLotMVC to Use CarLotWebAPI | 1595 |
| Summary | 1601 |
| Index | 1603 |

About the Authors



Andrew Troelsen has more than 20 years of experience in the software industry. During this time he has worked as a developer, educator, author, public speaker, and now team lead and lead engineer at Thomson Reuters. He is the author of numerous books in the Microsoft universe covering C++-based COM development with ATL, COM and .NET interoperability, Visual Basic, and the award-winning C# and the .NET platform (which would be this book right here). He has a master's of science degree in software engineering (MSSE) from the University of St. Thomas and is working on a second master's of science degree in computational linguistics (CLMS) from the University of Washington.



Philip Japikse's career with computers began in the mid-1980s building PC's, networking them, and writing software. Now, Phil focuses on the software development, enterprise architecture, and agile transformation. A Microsoft MVP since 2009, Phil is a passionate member of the developer community, leads the Cincinnati .NET User Group (www.cinnug.org), founded the Cincinnati Day of Agile (www.dayofagile.org), and is content director and co-host for the Hallway Conversations podcast (www.hallwayconversations.com). You can find Phil in person speaking at conferences in the US and Europe, and online (twitter) at [@skimedic](https://twitter.com/skimedic), and (blogging) at <http://www.skimedic.com>. Outside of tech, Phil is a proud husband and father of three, an avid skier (20 year member of the National Ski Patrol), and boater.

About the Technical Reviewer



Andy Olsen is a freelance developer and instructor based in Swansea in the United Kingdom. Andy has worked with .NET since its first release and has worked with all versions up to and including .NET 4.6 and the beta release of ASP.NET 5. Andy also spends much of his time working with emerging and mature web technologies and frameworks such as Angular, Ember, Bootstrap, and Node.

Away from work, Andy enjoys running, skiing, and watching football (his playing days are over). You can reach Andy at andy@olsensoft.com.

Acknowledgments

Andrew Troelsen: As always, I would like to offer a heartfelt thank-you to the entire team at Apress. I have been lucky to have worked with Apress on a variety of books since 2001. Beyond publishing high-quality technical material, the staff is excellent, and without them this book would not be possible. Thanks, everyone!

I also want to thank my (new) co-author Philip Japikse. Thanks, Phil, for working hard to maintain the same approachable vibe of the book, while still adding your own personal expertise and voice. I believe our book (and those who read it) will most certainly benefit from this new partnership!

Last but not least, I want to thank my wife, Mandy, and my son, Soren, for supporting me on my latest writing project: thanks, guys. Love you much.

Philip Japikse: I also want to thank Apress and the entire team involved in writing this book. This is my second book effort with Apress, and I am very impressed with the dedication and level of support we received during the writing process. I also want to thank Andrew for inviting me to sit at the table with him on this project. This book has been a staple of my .NET career from the beginning; I have hard copies of every single edition in my library! I am very proud of this work and the collaboration involved in getting this edition to market. I want to also thank you, the reader, for reading this book and hope that you will find it as helpful in your career as it has been in mine. Lastly, I couldn't have done this without my family and the support I've had from them. Between reading my work and proofing it and their understanding of the time involved, I couldn't have done it without you! Love you all!

Introduction

The first edition of this book was released in 2001 at the same time Microsoft released the Beta 2 build of .NET 1.0. Working on that first edition was certainly a challenge, given that the APIs and C# language were in a bit of flux during the authoring process. At that time, the entirety of the .NET platform was quite manageable from a developer's point of view. Windows Forms was the only desktop GUI API option in the platform, ASP.NET was exclusively focused on the web-form programming model, and C# was a lean and mean OOP.

Throughout the first six editions of this text, I have been the sole author responsible for updating the book to account for the numerous changes to the C# language and new APIs in the .NET platform. This book has been updated over the last 14 years to account for the Language Integrated Query (LINQ) programming model, Windows Presentation Foundation (WPF), Windows Communication Foundation (WCF), new threading models and keywords, new development tools, and changes to the web-centric programming framework (among many other things).

Beginning with this seventh edition, it became clear to me that a complete update of the book would have taken an extremely long time on my own. To be sure, my own life has become much busier than it was in 2001 (or even 2011; I suspect becoming a father has something to do with this or maybe too many graduate school classes...hmm).

In any case, when Apress approached me to update the book for the latest edition of the .NET platform, we considered a number of different approaches to get the book out in a timely manner. Eventually, we agreed it might be time to bring in a helping and capable hand to update portions of the text. Apress suggested that I meet with Philip Japikse to see whether he might be a good match. After a series of phone conversations, e-mail threads, and some careful thought, I was happy to bring him onboard to work on this project. I am happy to announce *C# 6.0 and the .NET 4.6 Framework* has been a joint effort between myself and co-author Philip Japikse. Please allow Philip to introduce himself..

—Andrew Troelsen

Take It Away, Philip!

When Microsoft released the early betas of .NET, I was already firmly entrenched in Microsoft technology. I had migrated over from other technologies to Visual Basic, building client applications as well as classic ASP web sites using VB and MTS. While these tools worked well in their day, I could see the end coming. I was examining other technology stacks, and that's what brought me to the first edition of this book. I read it cover to cover and saw not only the promise of .NET but the importance of this book in my technology library. Having one book that covers C# and the complete .NET ecosystem is invaluable. I can't tell how many copies of the book I've sold for Apress over the years, but I've recommended every edition to my customers and attendees as the first book to buy on C# and .NET. Whether you are getting started with .NET or just need to know what's new in the latest version, I have never found a better book.

I had already written one book for Apress on Windows 8.1 and C#, so I was familiar with the team and impressed by the way Apress conducts business and supports their authors. When my editor reached out to me to ask whether I would collaborate on the seventh edition of “the Troelsen book” (as I’ve always referred to it), I was thrilled and honored. This has truly been a labor of love, and I can’t say enough how thrilled and excited I am to be part of this book. I hope you enjoy reading it as much as I’ve enjoyed writing it and working with Andrew and the awesome team at Apress.

—Philip Japikse

We’re a Team That Includes *You*

Technology authors write for a demanding group of people (for the best of possible reasons). You know that building software solutions using any platform or language is extremely complicated and is specific to your department, company, client base, and subject matter. Perhaps you work in the electronic publishing industry, develop systems for the state or local government, or work at NASA or a branch of the military. Collectively, we have worked in a variety of industries, including developing children’s educational software (Oregon Trail/Amazon Trail), various enterprise systems, and projects within the medical and financial industries. The chances are almost 100 percent that the code you write at your place of employment has little to do with the code we have authored over the years.

Therefore, in this book, we have deliberately chosen to avoid creating demonstrations that tie the example code to a specific industry or vein of programming. Given this, we explain C#, OOP, the CLR, and the .NET base class libraries using industry-agnostic examples. Rather than having every blessed example fill a grid with data, calculate payroll, or whatnot, we stick to subject matter we can all relate to: automobiles (with some geometric structures and employee payroll systems thrown in for good measure). And that’s where you come in.

Our job is to explain the C# programming language and the core aspects of the .NET platform the best we possibly can. As well, we will do everything we can to equip you with the tools and strategies you need to continue your studies at this book’s conclusion.

Your job is to take this information and apply it to your specific programming assignments. We obviously understand that your projects most likely don’t revolve around automobiles with friendly pet names (Zippy the BMW or a Yugo named Clunker, among others), but that’s what applied knowledge is all about!

Rest assured, once you understand the topics and concepts presented within this text, you will be in a perfect position to build .NET solutions that map to your own unique programming environment.

An Overview of This Book

C# 6.0 and the .NET 4.6 Framework is logically divided into eight distinct parts, each of which contains a number of related chapters. Here is a part-by-part and chapter-by-chapter breakdown of the text.

Part I: Introducing C# and the .NET Platform

The purpose of Part I is to acclimate you to the nature of the .NET platform and various development tools (including cross-platform IDEs) used during the construction of .NET applications.

Chapter 1: The Philosophy of .NET

This first chapter functions as the backbone for the remainder of the text. The primary goal of this chapter is to acquaint you with a number of .NET-centric building blocks, such as the Common Language Runtime, Common Type System, Common Language Specification, and base class libraries. Here, you will take an initial look at the C# programming language and the .NET assembly format. We wrap up by examining the platform-independent nature of the .NET platform.

Chapter 2: Building C# Applications

The goal of this chapter is to introduce you to the process of compiling C# source code files using various tools and techniques. Here, you will learn about the role of the Microsoft Express development tools and the completely free (and fully functional) Visual Studio Community Edition upon which this book is based. We also touch on the role of the Xamarin IDE and how it enables development of .NET applications on Linux and Mac OS X operating systems. You will also learn how to configure your development machine with a local installation of the all-important .NET 4.6 Framework SDK documentation.

Part II: Core C# Programming

The topics presented in this part of the book are quite important because you will use them regardless of which type of .NET software you intend to develop (e.g., web applications, desktop GUI applications, code libraries, or Windows services). Here, you will learn about the fundamental data types of .NET, work with text manipulation, and learn the role of various C# parameter modifiers (including optional and named arguments).

Chapter 3: Core C# Programming Constructs, Part I

This chapter begins your formal investigation of the C# programming language. Here, you will learn about the role of the `Main()` method and numerous details regarding the intrinsic data types of the .NET platform, including the manipulation of textual data using `System.String` and `System.Text.StringBuilder`. You will also examine iteration and decision constructs, narrowing and widening operations, and the unchecked keyword.

Chapter 4: Core C# Programming Constructs, Part II

This chapter completes your examination of the core aspects of C#, beginning with the construction of overloaded type methods and defining parameters using the `out`, `ref`, and `params` keywords. This chapter will examine two C# features called *arguments* and *optional parameters*. You will also learn how to create and manipulate arrays of data, define nullable data types (with the `?` and `??` operators), and understand the distinction between value types (including enumerations and custom structures) and reference types.

Part III: Object-Oriented Programming with C#

In this part, you will come to understand the core constructs of the C# language, including the details of object-oriented programming. This part will also examine how to process runtime exceptions and will dive into the details of working with strongly typed interfaces.

Chapter 5: Understanding Encapsulation

This chapter begins your examination of object-oriented programming (OOP) using the C# programming language. After you are introduced to the pillars of OOP (encapsulation, inheritance, and polymorphism), the remainder of this chapter will show you how to build robust class types using constructors, properties, static members, constants, and read-only fields. You will wrap up with an examination of partial type definitions, object initialization syntax, and automatic properties.

Chapter 6: Understanding Inheritance and Polymorphism

Here, you will examine the remaining pillars of OOP (inheritance and polymorphism), which allow you to build families of related class types. As you do this, you will examine the role of virtual methods, abstract methods (and abstract base classes), and the nature of the polymorphic interface. Last but not least, this chapter will explain the role of the supreme base class of the .NET platform, `System.Object`.

Chapter 7: Understanding Structured Exception Handling

The point of this chapter is to discuss how to handle runtime anomalies in your code base through the use of structured exception handling. Not only will you learn about the C# keywords that allow you to handle such problems (`try`, `catch`, `throw`, `when`, and `finally`), but you will also come to understand the distinction between application-level and system-level exceptions. In addition, this chapter will examine various tools within Visual Studio that allow you to debug the exceptions that escape your notice.

Chapter 8: Working with Interfaces

The material in this chapter builds upon your understanding of object-based development by covering the topic of interface-based programming. Here, you will learn how to define classes and structures that support multiple behaviors, how to discover these behaviors at runtime, and how to selectively hide particular behaviors using explicit interface implementation. In addition to creating a number of custom interfaces, you will also learn how to implement standard interfaces found within the .NET platform. You will use these to build objects that can be sorted, copied, enumerated, and compared.

Part IV: Advanced C# Programming

This part of the book will deepen your understanding of the C# language by walking you through a number of more advanced (but important) concepts. Here, you will complete your examination of the .NET type system by investigating interfaces and delegates. You will also learn about the role of generics, take a first look at Language Integrated Query, and examine a number of more advanced features of C# (e.g., extension methods, partial methods, and pointer manipulation).

Chapter 9: Collections and Generics

This chapter explores the topic of *generics*. As you will see, generic programming gives you a way to create types and type members, which contain various *placeholders* that can be specified by the caller. In a nutshell, generics greatly enhance application performance and type safety. Not only will you explore various generic types within the `System.Collections.Generic` namespace, but you will also learn how to build your own generic methods and types (with and without constraints).

Chapter 10: Delegates, Events, and Lambda Expressions

The purpose of Chapter 10 is to demystify the delegate type. Simply put, a .NET delegate is an object that points to other methods in your application. Using this type, you can build systems that allow multiple objects to engage in a two-way conversation. After you have examined the use of .NET delegates, you will then be introduced to the C# event keyword, which you can use to simplify the manipulation of raw delegate programming. You will wrap up this chapter by investigating the role of the C# lambda operator (`=>`) and exploring the connection between delegates, anonymous methods, and lambda expressions.

Chapter 11: Advanced C# Language Features

This chapter deepens your understanding of the C# programming language by introducing you to a number of advanced programming techniques. Here, you will learn how to overload operators and create custom conversion routines (both implicit and explicit) for your types. You will also learn how to build and interact with type indexers, as well as work with extension methods, anonymous types, partial methods, and C# pointers using an unsafe code context.

Chapter 12: LINQ to Objects

This chapter begins your examination of Language Integrated Query (LINQ). LINQ allows you to build strongly typed query expressions that can be applied to a number of LINQ targets to manipulate data in the broadest sense of the word. Here, you will learn about LINQ to Objects, which allows you to apply LINQ expressions to containers of data (e.g., arrays, collections, and custom types). This information will serve you well as you encounter a number of additional LINQ APIs throughout the remainder of this book (e.g., LINQ to XML, LINQ to DataSet, PLINQ, and LINQ to Entities).

Chapter 13: Understanding Object Lifetime

The final chapter of this section examines how the CLR manages memory using the .NET garbage collector. Here, you will come to understand the role of application roots, object generations, and the `System.GC` type. Once you understand the basics, you will examine the topics of disposable objects (using the `IDisposable` interface) and the finalization process (using the `System.Object.Finalize()` method). This chapter will also investigate the `Lazy<T>` class, which allows you to define data that will not be allocated until requested by a caller. As you will see, this feature can be helpful when you want to ensure you do not clutter the heap with objects that are not actually required by your programs.

Part V: Programming with .NET Assemblies

Part 5 dives into the details of the .NET assembly format. Not only will you learn how to deploy and configure .NET code libraries, but you will also come to understand the internal composition of a .NET binary image. This part also explains the role of .NET attributes and the role of resolving type information at runtime. This section will also explain the role of the Dynamic Language Runtime (DLR) and the C# `dynamic` keyword. Later chapters will examine some fairly advanced topics regarding assemblies, such as application domains, the syntax of CIL, and the construction of in-memory assemblies.

Chapter 14: Building and Configuring Class Libraries

At a high level, *assembly* is the term used to describe a *.dll or *.exe binary file created with a .NET compiler. However, the true story of .NET assemblies is far richer than that. Here, you will learn the distinction between single-file and multifile assemblies, as well as how to build and deploy each entity. You'll also examine how you can configure private and shared assemblies using XML-based *.config files and publisher policy assemblies. Along the way, you will investigate the internal structure of the global assembly cache (GAC).

Chapter 15: Type Reflection, Late Binding, and Attribute-Based Programming

Chapter 15 continues your examination of .NET assemblies by checking out the process of runtime type discovery using the `System.Reflection` namespace. Using the types of this namespace, you can build applications that can read an assembly's metadata on the fly. You will also learn how to load and create types at runtime dynamically using late binding. The final topic of this chapter will explore the role of .NET attributes (both standard and custom). To illustrate the usefulness of each of these topics, the chapter shows you how to construct an extendable Windows Forms application.

Chapter 16: Dynamic Types and the Dynamic Language Runtime

.NET 4.0 introduced a new aspect of the .NET runtime environment called the *dynamic language runtime*. Using the DLR and the C# 2010 `dynamic` keyword, you can define data that is not truly resolved until runtime. Using these features simplifies some complex .NET programming tasks dramatically. In this chapter, you will learn some practical uses of dynamic data, including how to leverage the .NET reflection APIs in a streamlined manner, as well as how to communicate with legacy COM libraries with a minimum of fuss and bother.

Chapter 17: Processes, AppDomains, and Object Contexts

Now that you have a solid understanding of assemblies, this chapter dives deeper into the composition of a loaded .NET executable. The goal of this chapter is to illustrate the relationship between processes, application domains, and contextual boundaries. These topics provide the proper foundation for Chapter 19, where you will examine the construction of multithreaded applications.

Chapter 18: Understanding CIL and the Role of Dynamic Assemblies

The goal of the final chapter in this section is twofold. In the first half (more or less), you will examine the syntax and semantics of CIL in much greater detail than in previous chapters. The remainder of this chapter will cover the role of the `System.Reflection.Emit` namespace. You can use these types to build software that can generate .NET assemblies in memory at runtime. Formally speaking, assemblies defined and executed in memory are termed *dynamic assemblies*.

Part VI: Introducing the .NET Base Class Libraries

By this point in the text, you have a solid handle on the C# language and the details of the .NET assembly format. Part VI leverages your newfound knowledge by exploring a number of commonly used services found within the base class libraries, including the creation of multithreaded applications, file I/O, and database access using ADO.NET. This part also covers the construction of distributed applications using Windows Communication Foundation and the LINQ to XML API.

Chapter 19: Multithreaded, Parallel, and Async Programming

This chapter examines how to build multithreaded applications and illustrates a number of techniques you can use to author thread-safe code. The chapter opens by revisiting the .NET delegate type to ensure, explaining a delegate's intrinsic support for asynchronous method invocations. Next, you will investigate the types within the `System.Threading` namespace. The remainder of this chapter covers the Task Parallel Library (TPL). Using the TPL, .NET developers can build applications that distribute their workload across all available CPUs in a wickedly simple manner. At this point, you will also learn about the role of Parallel LINQ, which provides a way to create LINQ queries that scale across multiple machine cores. We wrap up by examining various C# keywords, which integrate asynchronous method calls directly into the language.

Chapter 20: File I/O and Object Serialization

The `System.IO` namespace allows you to interact with a machine's file and directory structure. Over the course of this chapter, you will learn how to create (and destroy) a directory system programmatically. You will also learn how to move data into and out of various streams (e.g., file based, string based, and memory based). The latter part of this chapter will examine the object serialization services of the .NET platform. Simply put, serialization allows you to persist the state of an object (or a set of related objects) into a stream for later use. Deserialization (as you might expect) is the process of plucking an object from the stream into memory for consumption by your application. After you understand the basics, you will learn how to customize the serialization process using the `ISerializable` interface and a set of .NET attributes.

Chapter 21: ADO.NET Part I: The Connected Layer

In this first of three database-centric chapters, you will take your first look at the database access API of the .NET platform, ADO.NET. Specifically, this chapter will introduce you to the role of .NET data providers and how to communicate with a relational database using the connected layer of ADO.NET, which is represented by connection objects, command objects, transaction objects, and data reader objects. Be aware that this chapter will also walk you through the creation of a custom database and the first iteration of a custom data access library (`AutoLotDAL.dll`).

Chapter 22: ADO.NET Part II: The Disconnected Layer

This chapter continues your study of database manipulation by examining the disconnected layer of ADO.NET. Here, you will learn the role of the `DataSet` type and data adapter objects. You will also learn about the many tools of Visual Studio 2010 that can greatly simplify the creation of data-driven applications. Along the way, you will learn how to bind `DataTable` objects to user interface elements, as well as how to apply LINQ queries to in-memory `DataSet` objects using LINQ to `DataSet`.

Chapter 23: ADO.NET Part III: The Entity Framework

This chapter wraps up your investigation of ADO.NET by examining the role of the Entity Framework (EF). Essentially, EF is a way for you to author data-access code using strongly typed classes that directly map to your business model. Here, you will come to understand the role of the EF `DbContext`, using data annotations to shape your database and implementing repositories for encapsulating common code, transaction support, migrations, concurrency, and interception. While doing so, you will learn to interact with relational databases using LINQ to Entities. You will also build the final version of your custom data-access library (`AutoLotDAL.dll`), which you will use in several of the remaining chapters of the book.

Chapter 24: Introducing LINQ to XML

Chapter 12 introduced you to the core LINQ programming model—specifically LINQ to Objects. Here, you will deepen your understanding of Language Integrated Query by examining how to apply LINQ queries to XML documents. You will begin by learning about the “warts” that were present in .NET’s initial foray into XML manipulation as you use the types of the `System.Xml.dll` assembly. With this brief history lesson behind you, you will explore how to create XML documents in memory, how to persist them to the hard drive, and how to navigate their contents using the LINQ programming model (LINQ to XML).

Chapter 25: Introducing Windows Communication Foundation

Until this point in the book, all the sample applications have executed on a single computer. In this chapter, you will learn about the Windows Communication Foundation (WCF) API that allows you to build distributed applications in a symmetrical manner, regardless of their underlying plumbing. This chapter will expose you to the construction of WCF services, hosts, and clients. As you will see, WCF services are extremely flexible because they allow clients and hosts to leverage XML-based configuration files to specify addresses, bindings, and contracts declaratively.

Part VII: Windows Presentation Foundation

The initial desktop GUI API supported by the .NET Platform was termed Windows Forms. While this API is still fully supported in the framework, .NET 3.0 introduced programmers to an amazing API called Windows Presentation Foundation (WPF). This API has quickly become the heir apparent to the Windows Forms desktop programming model. In essence, WPF allows you to build desktop applications that incorporate vector graphics, interactive animations, and data-binding operations using a declarative markup grammar called XAML. Furthermore, the WPF control architecture provides a trivial way to restyle the look and feel of a typical control radically using little more than some well-formed XAML.

Chapter 26: Introducing Windows Presentation Foundation and XAML

Essentially, WPF allows you to build extremely interactive and media-rich front ends for desktop applications (and indirectly, web applications). Unlike Windows Forms, this supercharged UI framework integrates a number of key services (e.g., 2D and 3D graphics, animations, and rich documents) into a single, unified object model. In this chapter, you will begin your examination of WPF and the Extendable Application Markup Language (XAML). Here, you will learn how to build WPF programs without XAML, as well as using nothing but XAML, and by using a combination of both approaches. You will wrap up the chapter by building a custom XAML editor that you will use for the remainder of the WPF-centric chapters.

Chapter 27: Programming with WPF Controls

This chapter will expose you to the process of using intrinsic WPF controls and layout managers. For example, you will learn to build menu systems, splitter windows, toolbars, and status bars. This chapter will also introduce you to a number of WPF APIs (and their related controls), including the WPF Documents API, the WPF Ink API, commands, routed events, the data-binding model, and dependency properties.

Chapter 28: WPF Graphics Rendering Services

WPF is a graphically intensive API; given this fact, WPF provides three ways to render graphics: shapes, drawings and geometrics, and visuals. In this chapter, you will evaluate each option and learn about a number of important graphics primitives (e.g., brushes, pens, and transformations) along the way. This chapter will also examine a ways to incorporate vector images into your WPF graphics, as well as how to perform hit-testing operations against graphical data.

Chapter 29: Resources, Animations, Styles, and Templates

This chapter will introduce you to three important (and interrelated) topics that will deepen your understanding of the Windows Presentation Foundation API. The first order of business is to learn the role of logical resources. As you will see, the logical resource (also termed an *object resource*) system provides a way for you to name and refer to commonly used objects within a WPF application. Next, you will learn how to define, execute, and control an animation sequence. Despite what you might be thinking, however, WPF animations are not limited to the confines of video game or multimedia applications. You will wrap up the chapter by learning about the role of WPF styles. Similar to a web page that uses CSS or the ASP.NET theme engine, a WPF application can define a common look and feel for a set of controls.

Chapter 30: Notifications, Commands, Validation, and MVVM

This chapter begins by examining three core framework capabilities: notifications, WPF commands, and validation. In the notifications section, you will learn about observable models and collections and how they keep your application data and UI in sync. Next, you dig deeper into commands, building custom commands to encapsulate your code. In the validation section, you learn how to use the several validation mechanisms available to use in WPF applications. The chapter closes with an examination of the Model View ViewModel (MVVM) pattern and ends by creating an application that demonstrates the MVVM pattern in action.

Part VIII: ASP.NET

Part 8 is devoted to an examination of constructing web applications using the ASP.NET programming API. Microsoft designed ASP.NET to model the creation of desktop user interfaces by layering an event-driven, object-oriented framework on top of a standard HTTP request/response. The first three chapters cover the foundation of web programming and Web Forms, and the final chapter covers the two newest entries into ASP.NET: MVC and Web API.

Chapter 31: Introducing ASP.NET Web Forms

This chapter begins your study of web application development using ASP.NET. As you will see, server-side scripting code has now been replaced with real object-oriented languages (e.g., C# and VB .NET). This chapter will examine the construction of an ASP.NET web page, the underlying programming model, and other key aspects of ASP.NET, such as your choice of web server and the use of `Web.config` files.

Chapter 32: ASP.NET Web Controls, Master Pages, and Themes

Whereas the previous chapter showed you how to construct ASP.NET Page objects, this chapter will examine the controls that populate the internal control tree. Here, you will examine the core ASP.NET web controls, including validation controls, the intrinsic site navigation controls, and various data-binding operations. This chapter will also illustrate the role of master pages and the ASP.NET theme engine, which is a server-side alternative to traditional style sheets.

Chapter 33: ASP.NET State Management Techniques

This chapter extends your understanding of ASP.NET by examining various ways to handle state management under .NET. Like classic ASP, ASP.NET allows you to create cookies and application-level and session-level variables quite easily. However, ASP.NET also introduces a new state management technique: the application cache. After you look at the numerous ways to handle state with ASP.NET, you will examine the role of the `HttpApplication` base class and learn how to alter the runtime behavior of your web application dynamically using the `Web.config` file.

Chapter 34: ASP.NET MVC and ASP.NET Web API

This chapter covers the two newest and related ASP.NET frameworks: MVC and Web API. ASP.NET MVC is based on the Model View Controller pattern, and after getting an understanding, you will build an MVC application. You will learn about Visual Studio scaffolding, routing, controllers, actions, and views. Next, you will build a Web API RESTful service to handle all create, read, update, delete (CRUD) operations on the Inventory data (using `AutoLotDAL`), and finally you will update your MVC application to use the new service instead of calling `AutoLotDAL` directly.

Downloadable Appendixes

In addition to the printed material, the ZIP file containing the source code for this book (available from the Apress web site, www.apress.com) contains additional appendix chapters distributed as PDFs. These bonus chapters cover a number of additional APIs in the .NET platform that you might find useful in your line of work. Specifically, you will find the following bonus material:

- Appendix A, “Programming with Windows Forms”
- Appendix B, “Platform-Independent .NET Development with Mono”

The first appendix will provide you with a foundation in the Windows Forms desktop API and give you the background necessary to recreate some of the desktop GUIs found in the early chapters of the text (until we cover Windows Presentation Foundation). The second chapter is taken from an older edition of this text; it covers the role of the Mono platform in a bit more detail than found in Chapters 1 and 2 of this book. Do be aware however that Appendix B shows screen shots of the older MonoDevelop IDE, which has been replaced by Xamarin Studio (covered in Chapter 2). Nevertheless, the core Mono code examples work as expected.

Obtaining This Book's Source Code

You can find all the code examples contained in this book available as a free download from the Apress website (www.apress.com). Simply look up the title of this book and use the download link on the home page. Once you have downloaded the correct *.zip file, unzip the contents. You will find that the code projects have been partitioned on a chapter-by-chapter basis.

On a related note, be aware that you will find “Source Code” notes, such as the following, in all the book's chapters. These notes serve as your visual cue that you can load the example under discussion into Visual Studio for further examination and modification.

■ **Source Code** This is a source code note that refers you to a specific directory in the ZIP archive.

To open a solution into Visual Studio, use the File ► Open ► Project/Solution... menu option and then navigate to the correct *.sln file within the correct subdirectory of the unzipped archive.

Obtaining Updates for This Book

As you read through this text, you might find an occasional grammatical or code error (although we sure hope not). If this is the case, please accept our apologies. Being human, a glitch or two might be present, despite our best efforts. If this is the case, you can obtain the current errata list from the Apress web site at www.apress.com (again, this is located on the home page for this book). As well, you can use this area to notify us of any errors you might find.

PART I



Introducing C# and the .NET Platform

CHAPTER 1



The Philosophy of .NET

Microsoft's .NET platform (and the related C# programming language) were formally introduced circa 2002 and have quickly become a mainstay of modern-day software development. As mentioned in the book's introductory section, the goal of this text is twofold. The first order of business is to provide you with deep and detailed examination of the syntax and semantics of C#. The second (equally important) order of business is to illustrate the use of numerous .NET APIs, including database access with ADO.NET and the Entity Framework (EF), the LINQ technology set, WPF, WCF and web site development using ASP.NET. As they say, the journey of a thousand miles begins with a single step; and with this I welcome you to Chapter 1.

The point of this first chapter is to lay the conceptual groundwork for the remainder of the book. Here you will find a high-level discussion of a number of .NET-related topics such as assemblies, the Common Intermediate Language (CIL), and just-in-time (JIT) compilation. In addition to previewing some keywords of the C# programming language, you will also come to understand the relationship between various aspects of the .NET Framework, such as the Common Language Runtime (CLR), the Common Type System (CTS), and the Common Language Specification (CLS).

This chapter also provides you with a survey of the functionality supplied by the .NET base class libraries, sometimes abbreviated as BCLs. Here, you will also overview the language-agnostic and platform-independent nature of the .NET platform (yes, it's true; .NET is not confined to the Windows operating system). As you would hope, many of these topics are explored in further detail throughout the remainder of this text.

An Initial Look at the .NET Platform

Before Microsoft released the C# language and .NET platform, software developers who created applications for the Windows family of operating system frequently made use of the COM programming model. COM (which stands for the Component Object Model) allowed individuals to build libraries of code that could be shared across diverse programming languages. For example, a C++ programmer could build a COM library that could be used by a Visual Basic developer. The language-independent nature of COM was certainly useful; however, COM was plagued by complicated infrastructure and a fragile deployment model and was possible only on the Windows operating system.

Despite the complexity and limitations of COM, countless applications have been successfully created with this architecture. However, nowadays, a majority of applications created for the Windows family of operating systems are not created with the COM model. Rather, desktop applications, web sites, OS services, and libraries of reusable data access/business logic are created using the .NET platform.

Some Key Benefits of the .NET Platform

As mentioned, C# and the .NET platform were first introduced to the world in 2002 and were intended to offer a much more powerful, more flexible, and simpler programming model than COM. As you will see during the remainder of this book, the .NET Framework is a software platform for building systems on the Windows family of operating systems, as well as on numerous non-Microsoft operating systems such as Mac OS X and various Unix/Linux distributions. To set the stage, here is a quick rundown of some core features provided courtesy of .NET:

- *Interoperability with existing code:* This is (of course) a good thing. Existing COM software can commingle (i.e., interop) with newer .NET software, and vice versa. As of .NET 4.0 onward, interoperability has been further simplified with the addition of the `dynamic` keyword (covered in Chapter 16).
- *Support for numerous programming languages:* .NET applications can be created using any number of programming languages (C#, Visual Basic, F#, and so on).
- *A common runtime engine shared by all .NET-aware languages:* One aspect of this engine is a well-defined set of types that each .NET-aware language understands.
- *Language integration:* .NET supports cross-language inheritance, cross-language exception handling, and cross-language debugging of code. For example, you can define a base class in C# and extend this type in Visual Basic.
- *A comprehensive base class library:* This library provides thousands of predefined types that allow you to build code libraries, simple terminal applications, graphical desktop application, and enterprise-level web sites.
- *A simplified deployment model:* Unlike COM, .NET libraries are not registered into the system registry. Furthermore, the .NET platform allows multiple versions of the same *.dll to exist in harmony on a single machine.

You will see each of these topics (and many more) examined in the chapters to come.

Introducing the Building Blocks of the .NET Platform (the CLR, CTS, and CLS)

Now that you know some of the major benefits provided by .NET, let's preview three key (and interrelated) topics that make it all possible: the CLR, CTS, and CLS. From a programmer's point of view, .NET can be understood as a runtime environment and a comprehensive base class library. The runtime layer is properly referred to as the *Common Language Runtime*, or *CLR*. The primary role of the CLR is to locate, load, and manage .NET objects on your behalf. The CLR also takes care of a number of low-level details such as memory management, application hosting, coordinating threads, and performing basic security checks (among other low-level details).

Another building block of the .NET platform is the *Common Type System*, or *CTS*. The CTS specification fully describes all possible data types and all programming constructs supported by the runtime, specifies how these entities can interact with each other, and details how they are represented in the .NET metadata format (more information on metadata later in this chapter; see Chapter 15 for complete details).

Understand that a given .NET-aware language might not support every feature defined by the CTS. The *Common Language Specification*, or *CLS*, is a related specification that defines a subset of common types and programming constructs that all .NET programming languages can agree on. Thus, if you build .NET types that expose only CLS-compliant features, you can rest assured that all .NET-aware languages can consume them. Conversely, if you make use of a data type or programming construct that is outside of the

bounds of the CLS, you cannot guarantee that every .NET programming language can interact with your .NET code library. Thankfully, as you will see later in this chapter, it is simple to tell your C# compiler to check all of your code for CLS compliance.

The Role of the Base Class Libraries

In addition to the CLR, CTS, and CLS specifications, the .NET platform provides a base class library that is available to all .NET programming languages. Not only does this base class library encapsulate various primitives such as threads, file input/output (I/O), graphical rendering systems, and interaction with various external hardware devices, but it also provides support for a number of services required by most real-world applications.

The base class libraries define types that can be used to build any type of software application. For example, you can use ASP.NET to build web sites and REST services, WCF to build distributed systems, WPF to build desktop GUI applications, and so forth. As well, the base class libraries provide types to interact with XML documents, the directory and file system on a given computer, communicate with a relational databases (via ADO.NET), and so forth. From a high level, you can visualize the relationship between the CLR, CTS, CLS, and the base class library, as shown in Figure 1-1.

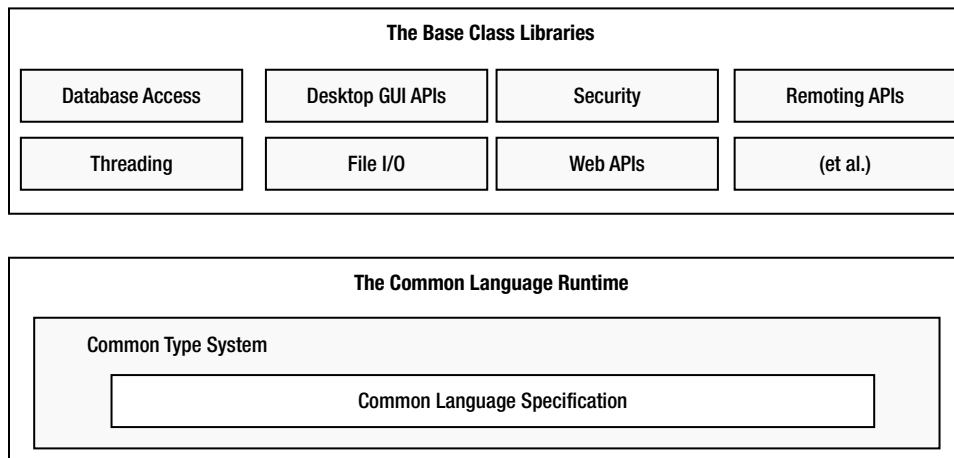

Figure 1-1. The CLR, CTS, CLS, and base class library relationship

What C# Brings to the Table

C# is a programming language whose core syntax looks *very* similar to the syntax of Java. However, calling C# a Java clone is inaccurate. In reality, both C# and Java are members of the C family of programming languages (e.g., C, Objective C, C++) and, therefore, share a similar syntax.

The truth of the matter is that many of C#'s syntactic constructs are modeled after various aspects of Visual Basic (VB) and C++. For example, like VB, C# supports the notion of class properties (as opposed to traditional getter and setter methods) and optional parameters. Like C++, C# allows you to overload operators, as well as create structures, enumerations, and callback functions (via delegates).

Moreover, as you work through this text, you will quickly see that C# supports a number of features traditionally found in various functional languages (e.g., LISP or Haskell) such as lambda expressions and anonymous types. Furthermore, with the advent of *Language Integrated Query* (LINQ), C# supports a number of constructs that make it quite unique in the programming landscape. Nevertheless, the bulk of C# is indeed influenced by C-based languages.

Because C# is a hybrid of numerous languages, the result is a product that is as syntactically clean (if not cleaner) as Java, is about as simple as VB, and provides just about as much power and flexibility as C++. Here is a partial list of core C# features that are found in all versions of the language:

- No pointers required! C# programs typically have no need for direct pointer manipulation (although you are free to drop down to that level if absolutely necessary, as shown in Chapter 11).
- Automatic memory management through garbage collection. Given this, C# does not support a `delete` keyword.
- Formal syntactic constructs for classes, interfaces, structures, enumerations, and delegates.
- The C++-like ability to overload operators for a custom type, without the complexity (e.g., making sure to “return `*this` to allow chaining” is not your problem).
- Support for attribute-based programming. This brand of development allows you to annotate types and their members to further qualify their behavior. For example, if you mark a method with the `[Obsolete]` attribute, programmers will see your custom warning message print out if they attempt to make use of the decorated member.

With the release of .NET 2.0 (circa 2005), the C# programming language was updated to support numerous new bells and whistles, most notably the following:

- The ability to build generic types and generic members. Using generics, you are able to build efficient and type-safe code that defines numerous *placeholders* specified at the time you interact with the generic item
- Support for anonymous methods, which allow you to supply an inline function anywhere a delegate type is required
- The ability to define a single type across multiple code files (or if necessary, as an in-memory representation) using the `partial` keyword

.NET 3.5 (released circa 2008) added even more functionality to the C# programming language, including the following features:

- Support for strongly typed queries (e.g., LINQ) used to interact with various forms of data. You will first encounter LINQ in Chapter 12.
- Support for anonymous types that allow you to model the *structure* of a type (rather than its behavior) on the fly in code.
- The ability to extend the functionality of an existing type (without subclassing) using extension methods.
- Inclusion of a lambda operator (`=>`), which even further simplifies working with .NET delegate types.
- A new object initialization syntax, which allows you to set property values at the time of object creation.

.NET 4.0 (released in 2010) updated C# yet again with a handful of features.

- Support for optional method parameters, as well as named method arguments.
- Support for dynamic lookup of members at runtime via the `dynamic` keyword. As you will see in Chapter 18, this provides a unified approach to invoking members on the fly, regardless of which framework the member implemented (COM, IronRuby, IronPython, or via .NET reflection services).
- Working with generic types is much more intuitive, given that you can easily map generic data to and from general `System.Object` collections via covariance and contravariance.

With the release of .NET 4.5, C# received a pair of new keywords (`async` and `await`), which greatly simplify multithreaded and asynchronous programming. If you have worked with previous versions of C#, you might recall that calling methods via secondary threads required a fair amount of cryptic code and the use of various .NET namespaces. Given that C# now supports language keywords that handle this complexity for you, the process of calling methods asynchronously is almost as easy as calling a method in a synchronous manner. Chapter 19 will cover these topics in detail.

This brings us to the current version of C# and .NET 4.6, which introduces a number of minor features that help streamline your codebase. You will see a number of details as you go through this text; however, here is a quick rundown of some of the new features found in C#:

- Inline initialization for automatic properties as well as support for read-only automatic properties
- Single-line method implementations using the C# lambda operator
- Support of “static imports” to provide direct access to static members within a namespace
- A null conditional operator, which helps check for null parameters in a method implementation
- A new string formatting syntax termed *string interpolation*
- The ability to filter exceptions using the new `when` keyword

Managed vs. Unmanaged Code

It is important to note that the C# language can be used only to build software that is hosted under the .NET runtime (you could never use C# to build a native COM server or an unmanaged C/C++-style application). Officially speaking, the term used to describe the code targeting the .NET runtime is *managed code*. The binary unit that contains the managed code is termed an *assembly* (more details on assemblies in just a bit). Conversely, code that cannot be directly hosted by the .NET runtime is termed *unmanaged code*.

As mentioned previously (and detailed later in this chapter and the next), the .NET platform can run on a variety of operating systems. Thus, it is quite possible to build a C# application on a Windows machine using Visual Studio and run the program on a Mac OS X machine using the Mono .NET runtime. As well, you could build a C# application on Linux using Xamarin Studio (see Chapter 2) and run the program on Windows, Mac, and so on. To be sure, the notion of a managed environment makes it possible to build, deploy, and run .NET programs on a wide variety of target machines.

Additional .NET-Aware Programming Languages

Understand that C# is not the only language that can be used to build .NET applications. Out of the box, Visual Studio provides you with five managed languages, specifically, C#, Visual Basic, C++/CLI, JavaScript, and F#.

■ **Note** F# is a .NET language based on the syntax of functional languages. While F# can be used as a purely functional language, it also has support for OOP constructs and the .NET base class libraries. If you are interested in learning more about this managed language, navigate online to the official F# home page, <http://msdn.microsoft.com/fsharp>.

In addition to the managed languages provided by Microsoft, there are .NET compilers for Smalltalk, Ruby, Python, COBOL, and Pascal (to name a few). Although this book focuses almost exclusively on C#, you might want to consult the following Wikipedia page, which lists a large number of programming languages that target the .NET framework:

https://en.wikipedia.org/wiki/List_of_CLI_languages

While I assume you are primarily interested in building .NET programs using the syntax of C#, I encourage you to visit this site, as you are sure to find many .NET languages worth investigating at your leisure (LISP.NET, anyone?).

Life in a Multilanguage World

As developers first come to understand the language-agnostic nature of .NET, numerous questions arise. The most prevalent of these questions would have to be, “If all .NET languages compile down to managed code, why do we need more than one language/compiler?”

There are a number of ways to answer this question. First, we programmers are a very particular lot when it comes to our choice of programming language. Some of us prefer languages full of semicolons and curly brackets with as few language keywords as possible. Others enjoy a language that offers more *human-readable* syntactic tokens (such as Visual Basic). Still others might want to leverage their mainframe skills while moving to the .NET platform (via the COBOL .NET compiler).

Now, be honest. If Microsoft were to build a single “official” .NET language derived from the BASIC family of languages, can you really say all programmers would be happy with this choice? Or, if the only “official” .NET language was based on Fortran syntax, imagine all the folks out there who would ignore .NET altogether. Because the .NET runtime couldn’t care less which language was used to build a block of managed code, .NET programmers can stay true to their syntactic preferences and share the compiled code among teammates, departments, and external organizations (regardless of which .NET language others choose to use).

Another excellent byproduct of integrating various .NET languages into a single, unified software solution is the simple fact that all programming languages have their own sets of strengths and weaknesses. For example, some programming languages offer excellent intrinsic support for advanced mathematical processing. Others offer superior support for financial calculations, logical calculations, interaction with mainframe computers, and so forth. When you take the strengths of a particular programming language and then incorporate the benefits provided by the .NET platform, everybody wins.

Of course, in reality the chances are quite good that you will spend much of your time building software using your .NET language of choice. However, once you master the syntax of one .NET language, it is easy to learn another. This is also quite beneficial, especially to the software consultants of the world. If your language of choice happens to be C# but you are placed at a client site that has committed to Visual Basic, you are still able to leverage the functionality of the .NET Framework, and you should be able to understand the overall structure of the code base with minimal fuss and bother.

An Overview of .NET Assemblies

Regardless of which .NET language you choose to program with, understand that despite that .NET binaries take the same file extension as unmanaged Windows binaries (*.dll or *.exe), they have absolutely no internal similarities. Specifically, .NET binaries do not contain platform-specific instructions but rather platform-agnostic *Intermediate Language (IL)* and type metadata. Figure 1-2 shows the big picture of the story thus far.

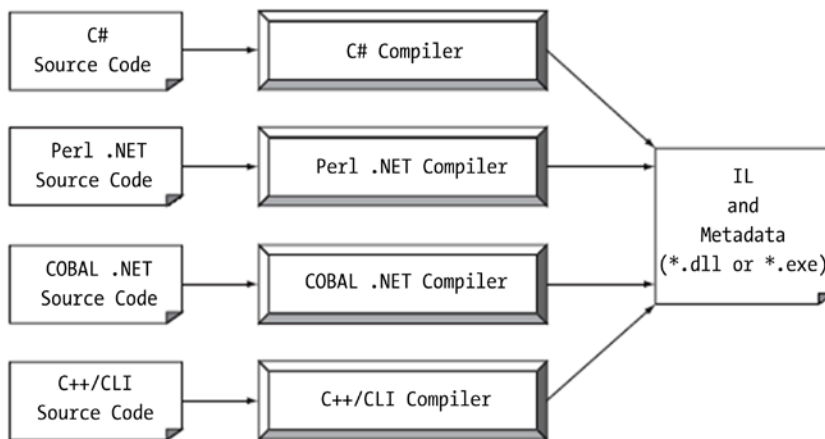

Figure 1-2. All .NET-aware compilers emit IL instructions and metadata

■ **Note** There is one point to be made regarding the abbreviation “IL.” IL is also known as Microsoft Intermediate Language (MSIL) or alternatively as the Common Intermediate Language (CIL). Thus, as you read the .NET literature, understand that IL, MSIL, and CIL are all describing essentially the same concept. In this text, I will use the abbreviation CIL to refer to this low-level instruction set.

When a *.dll or *.exe has been created using a .NET-aware compiler, the binary blob is termed an *assembly*. You will examine numerous details of .NET assemblies in Chapter 14. However, to facilitate the current discussion, you do need to understand some basic properties of this new file format.

As mentioned, an assembly contains CIL code, which is conceptually similar to Java bytecode in that it is not compiled to platform-specific instructions until absolutely necessary. Typically, “absolutely necessary” is the point at which a block of CIL instructions (such as a method implementation) is referenced for use by the .NET runtime.

In addition to CIL instructions, assemblies also contain *metadata* that describes in vivid detail the characteristics of every “type” within the binary. For example, if you have a class named `SportsCar`, the type metadata describes details such as `SportsCar`’s base class, which interfaces are implemented by `SportsCar` (if any), as well as a full description of each member supported by the `SportsCar` type. .NET metadata is always present within an assembly and is automatically generated by a .NET-aware language compiler.

Finally, in addition to CIL and type metadata, assemblies themselves are also described using metadata, which is officially termed a *manifest*. The manifest contains information about the current version of the assembly, culture information (used for localizing string and image resources), and a list of all externally referenced assemblies that are required for proper execution. You'll examine various tools that can be used to examine an assembly's types, metadata, and manifest information over the course of the next few chapters.

The Role of the Common Intermediate Language

Let's examine CIL code, type metadata, and the assembly manifest in a bit more detail. CIL is a language that sits above any particular platform-specific instruction set. For example, the following C# code models a trivial calculator. Don't concern yourself with the exact syntax for now, but do notice the format of the `Add()` method in the `Calc` class.

```
// Calc.cs
using System;
namespace CalculatorExample
{
    // This class contains the app's entry point.
    class Program
    {
        static void Main()
        {
            Calc c = new Calc();
            int ans = c.Add(10, 84);
            Console.WriteLine("10 + 84 is {0}.", ans);
            // Wait for user to press the Enter key before shutting down.
            Console.ReadLine();
        }
    }

    // The C# calculator.
    class Calc
    {
        public int Add(int x, int y)
        { return x + y; }
    }
}
```

After you compile this code file using the C# compiler (`csc.exe`), you end up with a single-file `*.exe` assembly that contains a manifest, CIL instructions, and metadata describing each aspect of the `Calc` and `Program` classes.

■ **Note** Chapter 2 examines how to use graphical IDEs (such as Visual Studio Community Edition) to compile your code files.

For example, if you were to open this assembly using `ildasm.exe` (examined a little later in this chapter), you would find that the `Add()` method is represented using CIL such as the following:

```
.method public hidebysig instance int32 Add(int32 x,
      int32 y) cil managed
{
  // Code size 9 (0x9)
  .maxstack 2
  .locals init (int32 V_0)
  IL_0000: nop
  IL_0001: ldarg.1
  IL_0002: ldarg.2
  IL_0003: add
  IL_0004: stloc.0
  IL_0005: br.s IL_0007
  IL_0007: ldloc.0
  IL_0008: ret
} // end of method Calc::Add
```

Don't worry if you are unable to make heads or tails of the resulting CIL for this method—Chapter 18 will describe the basics of the CIL programming language. The point to concentrate on is that the C# compiler emits CIL, not platform-specific instructions.

Now, recall that this is true of all .NET-aware compilers. To illustrate, assume you created this same application using Visual Basic, rather than C#.

```
' Calc.vb
Imports System

Namespace CalculatorExample
  ' A VB "Module" is a class that contains only
  ' static members.
  Module Program
    Sub Main()
      Dim c As New Calc
      Dim ans As Integer = c.Add(10, 84)
      Console.WriteLine("10 + 84 is {0}.", ans)
      Console.ReadLine()
    End Sub
  End Module

  Class Calc
    Public Function Add(ByVal x As Integer, ByVal y As Integer) As Integer
      Return x + y
    End Function
  End Class
End Namespace
```

If you examine the CIL for the `Add()` method, you find similar instructions (slightly tweaked by the Visual Basic compiler, `vbc.exe`).

```
.method public instance int32 Add(int32 x,
  int32 y) cil managed
{
  // Code size 8 (0x8)
  .maxstack 2
  .locals init (int32 V_0)
  IL_0000: ldarg.1
  IL_0001: ldarg.2
  IL_0002: add.ovf
  IL_0003: stloc.0
  IL_0004: br.s IL_0006
  IL_0006: ldloc.0
  IL_0007: ret
} // end of method Calc::Add
```

■ **Source Code** The `Calc.cs` and `Calc.vb` code files are included in the Chapter 1 subdirectory.

Benefits of CIL

At this point, you might be wondering exactly what is gained by compiling source code into CIL rather than directly to a specific instruction set. One benefit is language integration. As you have already seen, each .NET-aware compiler produces nearly identical CIL instructions. Therefore, all languages are able to interact within a well-defined binary arena.

Furthermore, given that CIL is platform-agnostic, the .NET Framework itself is platform-agnostic, providing the same benefits Java developers have grown accustomed to (e.g., a single code base running on numerous operating systems). In fact, there is an international standard for the C# language, and a large subset of the .NET platform and implementations already exists for many non-Windows operating systems (more details at the conclusion of this chapter).

Compiling CIL to Platform-Specific Instructions

Because assemblies contain CIL instructions rather than platform-specific instructions, CIL code must be compiled on the fly before use. The entity that compiles CIL code into meaningful CPU instructions is a JIT compiler, which sometimes goes by the friendly name of *Jitter*. The .NET runtime environment leverages a JIT compiler for each CPU targeting the runtime, each optimized for the underlying platform.

For example, if you are building a .NET application to be deployed to a handheld device (such as a Windows mobile device), the corresponding Jitter is well equipped to run within a low-memory environment. On the other hand, if you are deploying your assembly to a back-end company server (where memory is seldom an issue), the Jitter will be optimized to function in a high-memory environment. In this way, developers can write a single body of code that can be efficiently JIT compiled and executed on machines with different architectures.

Furthermore, as a given Jitter compiles CIL instructions into corresponding machine code, it will cache the results in memory in a manner suited to the target operating system. In this way, if a call is made to a method named `PrintDocument()`, the CIL instructions are compiled into platform-specific instructions on the first invocation and retained in memory for later use. Therefore, the next time `PrintDocument()` is called, there is no need to recompile the CIL.

■ **Note** It is also possible to perform a “pre-JIT” of an assembly when installing your application using the `ngen.exe` command-line tool that ships with the .NET Framework SDK. Doing so can improve startup time for graphically intensive applications.

The Role of .NET Type Metadata

In addition to CIL instructions, a .NET assembly contains full, complete, and accurate metadata, which describes every type (e.g., class, structure, enumeration) defined in the binary, as well as the members of each type (e.g., properties, methods, events). Thankfully, it is always the job of the compiler (not the programmer) to emit the latest and greatest type metadata. Because .NET metadata is so wickedly meticulous, assemblies are completely self-describing entities.

To illustrate the format of .NET type metadata, let’s take a look at the metadata that has been generated for the `Add()` method of the C# `Calc` class you examined previously (the metadata generated for the Visual Basic version of the `Add()` method is similar; again, more on the use of `ildasm` in just a bit).

TypeDef #2 (02000003)

```
-----
TypDefName: CalculatorExample.Calc (02000003)
Flags      : [NotPublic] [AutoLayout] [Class]
[AnsiClass] [BeforeFieldInit] (00100001)
Extends    : 01000001 [TypeRef] System.Object
Method #1 (06000003)
```

```
-----
MethodName: Add (06000003)
Flags      : [Public] [HideBySig] [ReuseSlot] (00000086)
RVA       : 0x00002090
ImplFlags : [IL] [Managed] (00000000)
CallConvntn: [DEFAULT]
hasThis
ReturnType: I4
2 Arguments
Argument #1: I4
Argument #2: I4
2 Parameters
(1) ParamToken : (08000001) Name : x flags: [none] (00000000)
(2) ParamToken : (08000002) Name : y flags: [none] (00000000)
```

Metadata is used by numerous aspects of the .NET runtime environment, as well as by various development tools. For example, the IntelliSense feature provided by tools such as Visual Studio is made possible by reading an assembly’s metadata at design time. Metadata is also used by various object- browsing utilities, debugging tools, and the C# compiler itself. To be sure, metadata is the backbone of numerous .NET technologies including Windows Communication Foundation (WCF), reflection, late binding, and object serialization. Chapter 15 will formalize the role of .NET metadata.

The Role of the Assembly Manifest

Last but not least, remember that a .NET assembly also contains metadata that describes the assembly itself (technically termed a *manifest*). Among other details, the manifest documents all external assemblies required by the current assembly to function correctly, the assembly's version number, copyright information, and so forth. Like type metadata, it is always the job of the compiler to generate the assembly's manifest. Here are some relevant details of the manifest generated when compiling the `Calc.cs` code file shown earlier in this chapter (assume you instructed the compiler to name your assembly `Calc.exe`):

```
.assembly extern mscorlib
{
  .publickeytoken = (B7 7A 5C 56 19 34 E0 89 )
  .ver 4:0:0:0
}
.assembly Calc
{
  .hash algorithm 0x00008004
  .ver 0:0:0:0
}
.module Calc.exe
.imagebase 0x00400000
.subsystem 0x00000003
.file alignment 0x00000200
.corflags 0x00000001
```

In a nutshell, this manifest documents the set of external assemblies required by `Calc.exe` (via the `.assembly extern` directive) as well as various characteristics of the assembly itself (e.g., version number, module name). Chapter 14 will examine the usefulness of manifest data in much more detail.

Understanding the Common Type System

A given assembly may contain any number of distinct types. In the world of .NET, *type* is simply a general term used to refer to a member from the set {class, interface, structure, enumeration, delegate}. When you build solutions using a .NET-aware language, you will most likely interact with many of these types. For example, your assembly might define a single class that implements some number of interfaces. Perhaps one of the interface methods takes an enumeration type as an input parameter and returns a structure to the caller.

Recall that the CTS is a formal specification that documents how types must be defined in order to be hosted by the CLR. Typically, the only individuals who are deeply concerned with the inner workings of the CTS are those building tools and/or compilers that target the .NET platform. It is important, however, for all .NET programmers to learn about how to work with the five types defined by the CTS in their language of choice. The following is a brief overview.

CTS Class Types

Every .NET-aware language supports, at the least, the notion of a *class type*, which is the cornerstone of object-oriented programming (OOP). A class may be composed of any number of members (such as constructors, properties, methods, and events) and data points (fields). In C#, classes are declared using the `class` keyword, like so:

```
// A C# class type with 1 method.
class Calc
{
    public int Add(int x, int y)
    {
        return x + y;
    }
}
```

Chapter 5 will begin your formal examination of building class types with C#; however, Table 1-1 documents a number of characteristics pertaining to class types.

Table 1-1. CTS Class Characteristics

| Class Characteristic | Meaning in Life |
|--|---|
| Is the class sealed? | Sealed classes cannot function as a base class to other classes. |
| Does the class implement any interfaces? | An interface is a collection of abstract members that provide a contract between the object and object user. The CTS allows a class to implement any number of interfaces. |
| Is the class abstract or concrete? | Abstract classes cannot be directly instantiated but are intended to define common behaviors for derived types. Concrete classes can be instantiated directly. |
| What is the visibility of this class? | Each class must be configured with a visibility keyword such as <code>public</code> or <code>internal</code> . Basically, this controls whether the class may be used by external assemblies or only from within the defining assembly. |

CTS Interface Types

Interfaces are nothing more than a named collection of abstract member definitions, which may be supported (i.e., implemented) by a given class or structure. In C#, interface types are defined using the `interface` keyword. By convention, all .NET interfaces begin with a capital letter *I*, as in the following example:

```
// A C# interface type is usually
// declared as public, to allow types in other
// assemblies to implement their behavior.
public interface IDraw
{
    void Draw();
}
```

On their own, interfaces are of little use. However, when a class or structure implements a given interface in its unique way, you are able to request access to the supplied functionality using an interface reference in a polymorphic manner. Interface-based programming will be fully explored in Chapter 8.

CTS Structure Types

The concept of a structure is also formalized under the CTS. If you have a C background, you should be pleased to know that these user-defined types (UDTs) have survived in the world of .NET (although they behave a bit differently under the hood). Simply put, a *structure* can be thought of as a lightweight class type having value-based semantics. For more details on the subtleties of structures, see Chapter 4. Typically, structures are best suited for modeling geometric and mathematical data and are created in C# using the `struct` keyword, as follows:

```
// A C# structure type.
struct Point
{
    // Structures can contain fields.
    public int xPos, yPos;

    // Structures can contain parameterized constructors.
    public Point(int x, int y)
    { xPos = x; yPos = y;}

    // Structures may define methods.
    public void PrintPosition()
    {
        Console.WriteLine("{0}, {1}", xPos, yPos);
    }
}
```

CTS Enumeration Types

Enumerations are a handy programming construct that allow you to group name-value pairs. For example, assume you are creating a video game application that allows the player to select one of three character categories (Wizard, Fighter, or Thief). Rather than keeping track of simple numerical values to represent each possibility, you could build a strongly typed enumeration using the `enum` keyword.

```
// A C# enumeration type.
enum CharacterType
{
    Wizard = 100,
    Fighter = 200,
    Thief = 300
}
```

By default, the storage used to hold each item is a 32-bit integer; however, it is possible to alter this storage slot if need be (e.g., when programming for a low-memory device such as a mobile device). Also, the CTS demands that enumerated types derive from a common base class, `System.Enum`. As you will see in Chapter 4, this base class defines a number of interesting members that allow you to extract, manipulate, and transform the underlying name-value pairs programmatically.

CTS Delegate Types

Delegates are the .NET equivalent of a type-safe, C-style function pointer. The key difference is that a .NET delegate is a *class* that derives from `System.MulticastDelegate`, rather than a simple pointer to a raw memory address. In C#, delegates are declared using the `delegate` keyword.

```
// This C# delegate type can "point to" any method  
// returning an int and taking two ints as input.  
delegate int BinaryOp(int x, int y);
```

Delegates are critical when you want to provide a way for one object to forward a call to another object and provide the foundation for the .NET event architecture. As you will see in Chapters 10 and 19, delegates have intrinsic support for multicasting (i.e., forwarding a request to multiple recipients) and asynchronous method invocations (i.e., invoking the method on a secondary thread).

CTS Type Members

Now that you have previewed each of the types formalized by the CTS, realize that most types take any number of *members*. Formally speaking, a type member is constrained by the set {constructor, finalizer, static constructor, nested type, operator, method, property, indexer, field, read-only field, constant, event}.

The CTS defines various *adornments* that may be associated with a given member. For example, each member has a given visibility trait (e.g., `public`, `private`, `protected`). Some members may be declared as `abstract` (to enforce a polymorphic behavior on derived types) as well as `virtual` (to define a canned, but overridable, implementation). Also, most members may be configured as `static` (bound at the class level) or `instance` (bound at the object level). The creation of type members is examined over the course of the next several chapters.

■ **Note** As described in Chapter 9, the C# language also supports the creation of generic types and generic members.

Intrinsic CTS Data Types

The final aspect of the CTS to be aware of for the time being is that it establishes a well-defined set of fundamental data types. Although a given language typically has a unique keyword used to declare a fundamental data type, all .NET language keywords ultimately resolve to the same CTS type defined in an assembly named `microsoft.dll`. Consider Table 1-2, which documents how key CTS data types are expressed in various .NET languages.

Table 1-2. *The Intrinsic CTS Data Types*

| CTS Data Type | VB Keyword | C# Keyword | C++/CLI Keyword |
|----------------|------------|------------|-------------------------------|
| System.Byte | Byte | byte | unsigned char |
| System.SByte | SByte | sbyte | signed char |
| System.Int16 | Short | short | short |
| System.Int32 | Integer | int | int or long |
| System.Int64 | Long | long | __int64 |
| System.UInt16 | UShort | ushort | unsigned short |
| System.UInt32 | UInteger | uint | unsigned int or unsigned long |
| System.UInt64 | ULong | ulong | unsigned __int64 |
| System.Single | Single | float | float |
| System.Double | Double | double | double |
| System.Object | Object | object | object^ |
| System.Char | Char | char | wchar_t |
| System.String | String | string | String^ |
| System.Decimal | Decimal | decimal | Decimal |
| System.Boolean | Boolean | bool | bool |

Given that the unique keywords of a managed language are simply shorthand notations for a real type in the System namespace, you no longer have to worry about overflow/underflow conditions for numerical data or how strings and Booleans are internally represented across different languages. Consider the following code snippets, which define 32-bit numerical variables in C# and Visual Basic, using language keywords as well as the formal CTS data type:

```
// Define some "ints" in C#.
int i = 0;
System.Int32 j = 0;
```

```
' Define some "ints" in VB.
Dim i As Integer = 0
Dim j As System.Int32 = 0
```

Understanding the Common Language Specification

As you are aware, different languages express the same programming constructs in unique, language-specific terms. For example, in C# you denote string concatenation using the plus operator (+), while in VB you typically make use of the ampersand (&). Even when two distinct languages express the same programmatic idiom (e.g., a function with no return value), the chances are good that the syntax will appear quite different on the surface.

```

// C# method returning nothing.
public void MyMethod()
{
    // Some interesting code...
}

' VB method returning nothing.
Public Sub MyMethod()
    ' Some interesting code...
End Sub

```

As you have already seen, these minor syntactic variations are inconsequential in the eyes of the .NET runtime, given that the respective compilers (`csc.exe` or `vbc.exe`, in this case) emit a similar set of CIL instructions. However, languages can also differ with regard to their overall level of functionality. For example, a .NET language might or might not have a keyword to represent unsigned data and might or might not support pointer types. Given these possible variations, it would be ideal to have a baseline to which all .NET-aware languages are expected to conform.

The CLS is a set of rules that describe in vivid detail the minimal and complete set of features a given .NET-aware compiler must support to produce code that can be hosted by the CLR, while at the same time be accessed in a uniform manner by all languages that target the .NET platform. In many ways, the CLS can be viewed as a *subset* of the full functionality defined by the CTS.

The CLS is ultimately a set of rules that compiler builders must conform to if they intend their products to function seamlessly within the .NET universe. Each rule is assigned a simple name (e.g., CLS Rule 6) and describes how this rule affects those who build the compilers as well as those who (in some way) interact with them. The *crème de la crème* of the CLS is Rule 1.

- *Rule 1:* CLS rules apply only to those parts of a type that are exposed outside the defining assembly.

Given this rule, you can (correctly) infer that the remaining rules of the CLS do not apply to the logic used to build the inner workings of a .NET type. The only aspects of a type that must conform to the CLS are the member definitions themselves (i.e., naming conventions, parameters, and return types). The implementation logic for a member may use any number of non-CLS techniques, as the outside world won't know the difference.

To illustrate, the following C# `Add()` method is not CLS compliant, as the parameters and return values make use of unsigned data (which is not a requirement of the CLS):

```

class Calc
{
    // Exposed unsigned data is not CLS compliant!
    public ulong Add(ulong x, ulong y)
    {
        return x + y;
    }
}

```

However, if you were to only make use of unsigned data internally in a method, as follows:

```
class Calc
{
    public int Add(int x, int y)
    {
        // As this ulong variable is only used internally,
        // we are still CLS compliant.
        ulong temp = 0;
        ...
        return x + y;
    }
}
```

you have still conformed to the rules of the CLS and can rest assured that all .NET languages are able to invoke the `Add()` method.

Of course, in addition to Rule 1, the CLS defines numerous other rules. For example, the CLS describes how a given language must represent text strings, how enumerations should be represented internally (the base type used for storage), how to define static members, and so forth. Luckily, you don't have to commit these rules to memory to be a proficient .NET developer. Again, by and large, an intimate understanding of the CTS and CLS specifications is typically of interest only to tool/compiler builders.

Ensuring CLS Compliance

As you will see over the course of this book, *C#* does define a number of programming constructs that are not CLS compliant. The good news, however, is that you can instruct the *C#* compiler to check your code for CLS compliance using a single .NET attribute.

```
// Tell the C# compiler to check for CLS compliance.
[assembly: CLSCompliant(true)]
```

Chapter 15 dives into the details of attribute-based programming. Until then, simply understand that the `[CLSCompliant]` attribute will instruct the *C#* compiler to check every line of code against the rules of the CLS. If any CLS violations are discovered, you receive a compiler error and a description of the offending code.

Understanding the Common Language Runtime

In addition to the CTS and CLS specifications, the final three-letter abbreviation (TLA) to contend with at the moment is the CLR. Programmatically speaking, the term *runtime* can be understood as a collection of services that are required to execute a given compiled unit of code. For example, when Java developers deploy software to a new computer, they need to ensure the machine has been installed with the Java Virtual Machine (JVM) in order to run their software.

The .NET platform offers yet another runtime system. The key difference between the .NET runtime and the various other runtimes I just mentioned is that the .NET runtime provides a single, well-defined runtime layer that is shared by *all* languages and platforms that are .NET-aware.

The crux of the CLR is physically represented by a library named `mscorlib.dll` (aka the Common Object Runtime Execution Engine). When an assembly is referenced for use, `mscorlib.dll` is loaded automatically, which in turn loads the required assembly into memory. The runtime engine is responsible for a number of tasks. First, it is the agent in charge of resolving the location of an assembly and finding the requested type within the binary by reading the contained metadata. The CLR then lays out the type in memory, compiles

the associated CIL into platform-specific instructions, performs any necessary security checks, and then executes the code in question.

In addition to loading your custom assemblies and creating your custom types, the CLR will also interact with the types contained within the .NET base class libraries when required. Although the entire base class library has been broken into a number of discrete assemblies, the key assembly is `microsoft.dll`, which contains a large number of core types that encapsulate a wide variety of common programming tasks, as well as the core data types used by all .NET languages. When you build .NET solutions, you automatically have access to this particular assembly.

Figure 1-3 illustrates the high-level workflow that takes place between your source code (which is making use of base class library types), a given .NET compiler, and the .NET execution engine.

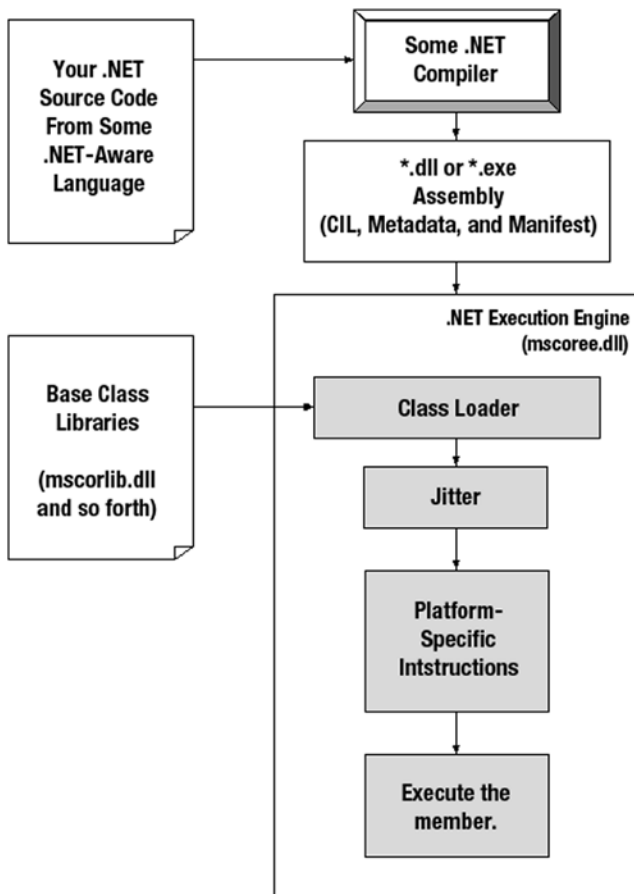

Figure 1-3. `mscorlib.dll` in action

The Assembly/Namespace/Type Distinction

Each of us understands the importance of code libraries. The point of framework libraries is to give developers a well-defined set of existing code to leverage in their applications. However, the C# language does not come with a language-specific code library. Rather, C# developers leverage the language-neutral .NET libraries. To keep all the types within the base class libraries well organized, the .NET platform makes extensive use of the *namespace* concept.

A namespace is a grouping of semantically related types contained in an assembly or possibly spread across multiple related assemblies. For example, the `System.IO` namespace contains file I/O-related types, the `System.Data` namespace defines basic database types, and so on. It is important to point out that a single assembly (such as `mscorlib.dll`) can contain any number of namespaces, each of which can contain any number of types.

To clarify, Figure 1-4 shows the Visual Studio Object Browser utility (which can be found under the View menu). This tool allows you to examine the assemblies referenced by your current project, the namespaces within a particular assembly, the types within a given namespace, and the members of a specific type. Note that the `mscorlib.dll` assembly contains many different namespaces (such as `System.IO`), each with its own semantically related types (e.g., `BinaryReader`).

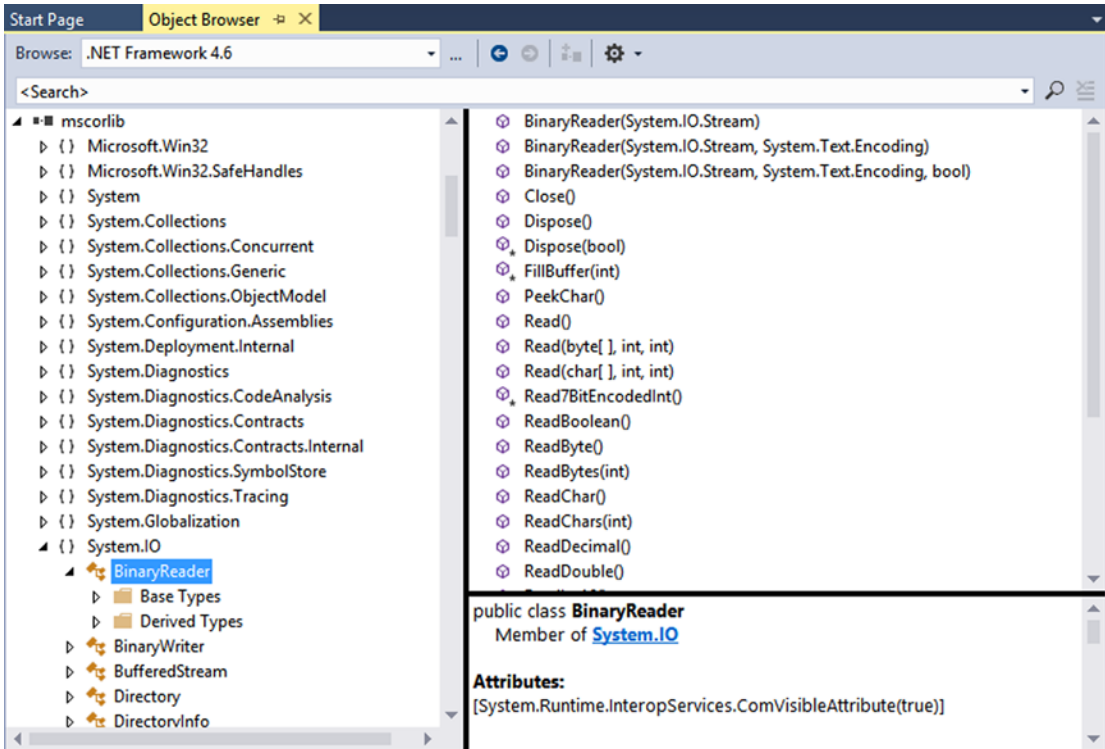

Figure 1-4. A single assembly can have any number of namespaces, and namespaces can have any number of types

The key difference between this approach and a language-specific library is that any language targeting the .NET runtime uses the *same* namespaces and *same* types. For example, the following three programs all illustrate the ubiquitous “Hello World” application, written in C#, VB, and C++/CLI:

// Hello world in C#.

```
using System;

public class MyApp
{
    static void Main()
    {
        Console.WriteLine("Hi from C#");
    }
}
```

' Hello world in VB.

```
Imports System
Public Module MyApp
    Sub Main()
        Console.WriteLine("Hi from VB")
    End Sub
End Module
```

// Hello world in C++/CLI.

```
#include "stdafx.h"
using namespace System;

int main(array<System::String ^> ^args)
{
    Console::WriteLine(L"Hi from C++/CLI");
    return 0;
}
```

Notice that each language is using the `Console` class defined in the `System` namespace. Beyond some obvious syntactic variations, these three applications look and feel very much alike, both physically and logically.

Clearly, one you are comfortable with your .NET programming language of choice, your next goal as a .NET developer is to get to know the wealth of types defined in the (numerous) .NET namespaces. The most fundamental namespace to get your hands around initially is named `System`. This namespace provides a core body of types that you will need to leverage time and again as a .NET developer. In fact, you cannot build any sort of functional C# application without at least making a reference to the `System` namespace, as the core data types (e.g., `System.Int32`, `System.String`) are defined here. Table 1-3 offers a rundown of some (but certainly not all) of the .NET namespaces grouped by related functionality.

The Role of the Microsoft Root Namespace

I’m sure you noticed while reading over the listings in Table 1-3 that `System` is the root namespace for a majority of nested namespaces (e.g., `System.IO`, `System.Data`). As it turns out, however, the .NET base class library defines a number of topmost root namespaces beyond `System`, the most useful of which is named `Microsoft`.

Table 1-3. A Sampling of .NET Namespaces

| .NET Namespace | Meaning in Life |
|--|--|
| System | Within System, you find numerous useful types dealing with intrinsic data, mathematical computations, random number generation, environment variables, and garbage collection, as well as a number of commonly used exceptions and attributes. |
| System.Collections System.Collections.Generic | These namespaces define a number of stock container types, as well as base types and interfaces that allow you to build customized collections. |
| System.Data System.Data.Common System.Data.EntityClient System.Data.SqlClient | These namespaces are used for interacting with relational databases using ADO.NET. |
| System.IO System.IO.Compression System.IO.Ports | These namespaces define numerous types used to work with file I/O, compression of data, and port manipulation. |
| System.Reflection System.Reflection.Emit | These namespaces define types that support runtime type discovery as well as dynamic creation of types. |
| System.Runtime.InteropServices | This namespace provides facilities to allow .NET types to interact with unmanaged code (e.g., C-based DLLs and COM servers), and vice versa. |
| System.Drawing System.Windows.Forms | These namespaces define types used to build desktop applications using .NET's original UI toolkit (Windows Forms). |
| System.Windows System.Windows.Controls System.Windows.Shapes | The System.Windows namespace is the root for several namespaces that represent the Windows Presentation Foundation (WPF) UI toolkit. |
| System.Linq System.Xml.Linq System.Data.DataSetExtensions | These namespaces define types used when programming against the LINQ API. |
| System.Web | This is one of many namespaces that allow you to build ASP.NET web applications. |
| System.Web.Http | This is one of many namespaces that allow you to build RESTful web services. |
| System.ServiceModel | This is one of many namespaces used to build distributed applications using the Windows Communication Foundation API. |
| System.Workflow.Runtime System.Workflow.Activities | These are two of many namespaces that define types used to build “workflow-enabled” applications using the Windows Workflow Foundation API. |
| System.Threading System.Threading.Tasks | This namespace defines numerous types to build multithreaded applications that can distribute workloads across multiple CPUs. |
| System.Security | Security is an integrated aspect of the .NET universe. In the security-centric namespaces, you find numerous types dealing with permissions, cryptography, and so on. |
| System.Xml | The XML-centric namespaces contain numerous types used to interact with XML data. |

Any namespace nested within Microsoft (e.g., `Microsoft.CSharp`, `Microsoft.ManagementConsole`, `Microsoft.Win32`) contains types that are used to interact with services unique to the Windows operating system. Given this point, you should not assume that these types could be used successfully on other .NET-enabled operating systems such as Mac OS X. For the most part, this text will not dig into the details of the Microsoft rooted namespaces, so be sure to consult the .NET Framework 4.6 SDK documentation if you are interested.

■ **Note** Chapter 2 will illustrate the use of the .NET Framework 4.6 SDK documentation, which provides details regarding every namespace, type, and member within the base class libraries.

Accessing a Namespace Programmatically

It is worth reiterating that a namespace is nothing more than a convenient way for us mere humans to logically understand and organize related types. Consider again the `System` namespace. From your perspective, you can assume that `System.Console` represents a class named `Console` that is contained within a namespace called `System`. However, in the eyes of the .NET runtime, this is not so. The runtime engine sees only a single class named `System.Console`.

In C#, the `using` keyword simplifies the process of referencing types defined in a particular namespace. Here is how it works. Let's say you are interested in building a graphical desktop application using the WPF API. While learning the types each namespace contains takes study and experimentation, here are some possible candidates to reference in your program:

// Here are some possible namespaces used to build a WPF application.

```
using System;                // General base class library types.
using System.Windows.Shapes; // Graphical rendering types.
using System.Windows.Controls; // Windows Forms GUI widget types.
using System.Data;           // General data-centric types.
using System.Data.SqlClient; // MS SQL Server data-access types.
```

Once you have specified some number of namespaces (and set a reference to the assemblies that define them), you are free to create instances of the types they contain. For example, if you are interested in creating an instance of the `Button` class (defined in the `System.Windows.Controls` namespace), you can write the following:

// Explicitly list the namespaces used by this file.

```
using System;
using System.Windows.Controls;

class MyGUIBuilder
{
    public void BuildUI()
    {
        // Create a button control.
        Button btnOK = new Button();
        ...
    }
}
```

Because your code file is importing the `System.Windows.Controls` namespace, the compiler is able to resolve the `Button` class as a member of this namespace. If you did not import the `System.Windows.Controls` namespace, you would be issued a compiler error. However, you are free to declare variables using a *fully qualified name* as well.

// Not listing System.Windows.Controls namespace!

```
using System;

class MyGUIBuilder
{
    public void BuildUI()
    {
        // Using fully qualified name.
        System.Windows.Controls.Button btnOK =
            new System.Windows.Controls.Button();
        ...
    }
}
```

While defining a type using the fully qualified name provides greater readability, I think you'd agree that the `C#` `using` keyword reduces keystrokes. In this text, I will avoid the use of fully qualified names (unless there is a definite ambiguity to be resolved) and opt for the simplified approach of the `C#` `using` keyword.

However, always remember that the `using` keyword is simply a shorthand notation for specifying a type's fully qualified name, and either approach results in the same underlying CIL (given that CIL code always uses fully qualified names) and has no effect on performance or the size of the assembly.

Referencing External Assemblies

In addition to specifying a namespace via the `C#` `using` keyword, you need to tell the `C#` compiler the name of the assembly containing the actual CIL implementation for the referenced type. As mentioned, many core .NET namespaces are defined within `mscorlib.dll`. However, by way of example, the `System.Drawing.Bitmap` class is contained within a separate assembly named `System.Drawing.dll`. A vast majority of the .NET Framework assemblies are located under a specific directory termed the *global assembly cache* (GAC). On a Windows machine, this can be located by default under `C:\Windows\Assembly\GAC`, as shown in Figure 1-5.

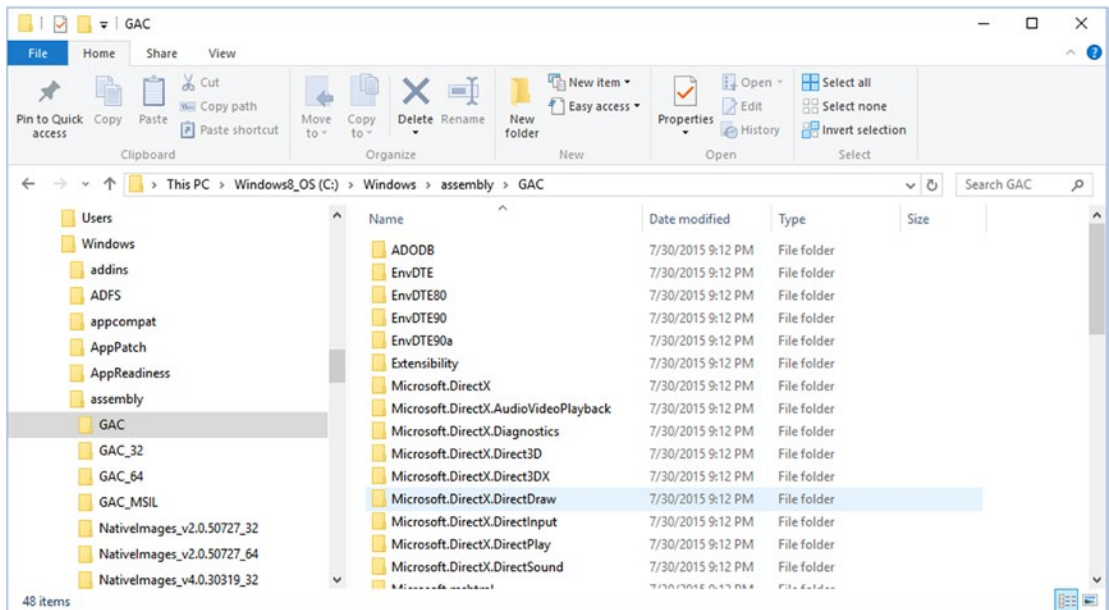

Figure 1-5. Many .NET libraries reside in the GAC

Depending on the development tool you are using to build your .NET applications, you will have various ways to inform the compiler which assemblies you want to include during the compilation cycle. You'll examine how to do so in Chapter 2, so I'll hold off on the details for now.

■ **Note** As you will see in Chapter 14, a Windows OS has multiple locations where framework libraries can be installed; however, this is generally encapsulated from the developer. On a non-Windows machine (such as Mac OS X or Linux), the location of the GAC depends on the .NET distribution.

Exploring an Assembly Using ildasm.exe

If you are beginning to feel a tad overwhelmed at the thought of gaining mastery over every namespace in the .NET platform, just remember that what makes a namespace unique is that it contains types that are somehow *semantically related*. Therefore, if you have no need for a user interface beyond a simple console application, you can forget all about the desktop and web namespaces (among others). If you are building a painting application, the database namespaces are most likely of little concern. Like any new set of prefabricated code, you learn as you go.

The Intermediate Language Disassembler utility (`ildasm.exe`), which ships with the .NET Framework, allows you to load up any .NET assembly and investigate its contents, including the associated manifest, CIL code, and type metadata. This tool allows a programmer to dive deeply into how their C# code maps to CIL and ultimately helps one understand the inner workings of the .NET platform. While you never *need* to use `ildasm.exe` to become a proficient .NET programmer, I highly recommend you fire up this tool from time to time to better understand how your C# code maps to runtime concepts.

■ **Note** You can easily run `ildasm.exe` by opening a Visual Studio command prompt and typing `ildasm` followed by the Enter key.

After you launch `ildasm.exe`, proceed to the File ► Open menu command and navigate to an assembly you would like to explore. By way of illustration, Figure 1-6 shows the `Calc.exe` assembly generated based on the `Calc.cs` file shown earlier in this chapter. `ildasm.exe` presents the structure of an assembly using a familiar tree-view format.

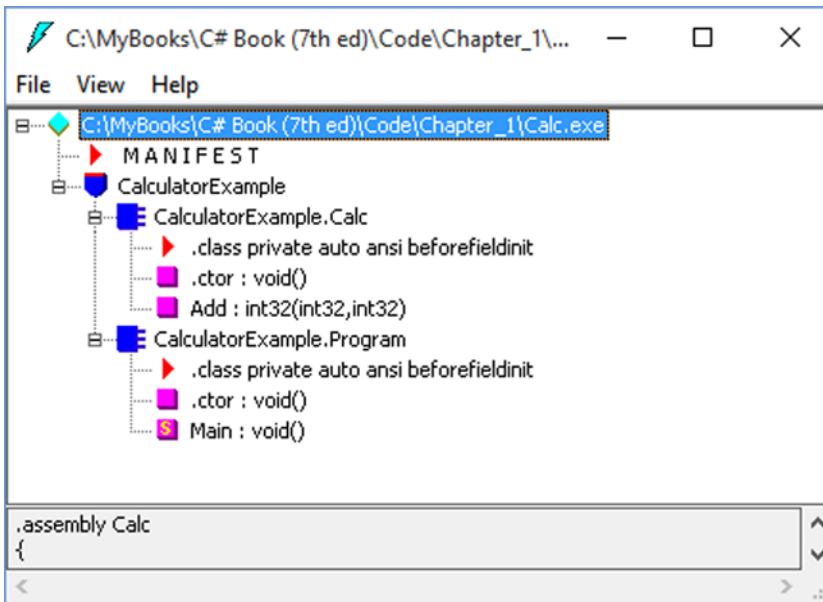

Figure 1-6. `ildasm.exe` allows you to see the CIL code, manifest, and metadata within a .NET assembly

Viewing CIL Code

In addition to showing the namespaces, types, and members contained in a given assembly, `ildasm.exe` allows you to view the CIL instructions for a given member. For example, if you were to double-click the `Main()` method of the `Program` class, a separate window would display the underlying CIL (see Figure 1-7).

```

CalculatorExample.Program::Main : void()
Find Find Next
.method private hidebysig static void Main() cil managed
{
    .entrypoint
    // Code size      42 (0x2a)
    .maxstack 3
    .locals init (class CalculatorExample.Calc U_0,
                 int32 U_1)
    IL_0000: nop
    IL_0001: newobj     instance void CalculatorExample.Calc::.ctor()
    IL_0006: stloc.0
    IL_0007: ldloc.0
    IL_0008: ldc.i4.s    10
    IL_000a: ldc.i4.s    84
    IL_000c: callvirt   instance int32 CalculatorExample.Calc::Add(int32,
                                                         int32)
    IL_0011: stloc.1
    IL_0012: ldstr     "10 + 84 is {0}."
    IL_0017: ldloc.1
    IL_0018: box       [mscorlib]System.Int32
    IL_001d: call     void [mscorlib]System.Console::WriteLine(string,
                                                         object)
    IL_0022: nop
    IL_0023: call     string [mscorlib]System.Console::ReadLine()
}

```

Figure 1-7. Viewing the underlying CIL

Viewing Type Metadata

If you want to view the type metadata for the currently loaded assembly, press Ctrl+M. Figure 1-8 shows the metadata for the Calc.Add() method.

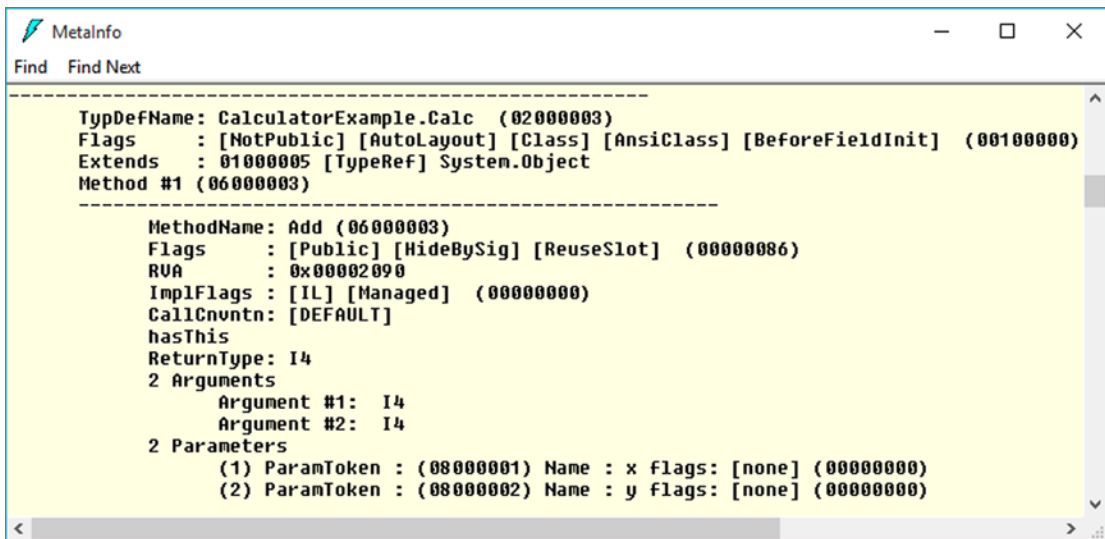

Figure 1-8. Viewing type metadata via ildasm.exe

Viewing Assembly Metadata (aka the Manifest)

Finally, if you are interested in viewing the contents of the assembly’s manifest (see Figure 1-9), simply double-click the MANIFEST icon in the main window of ildasm.

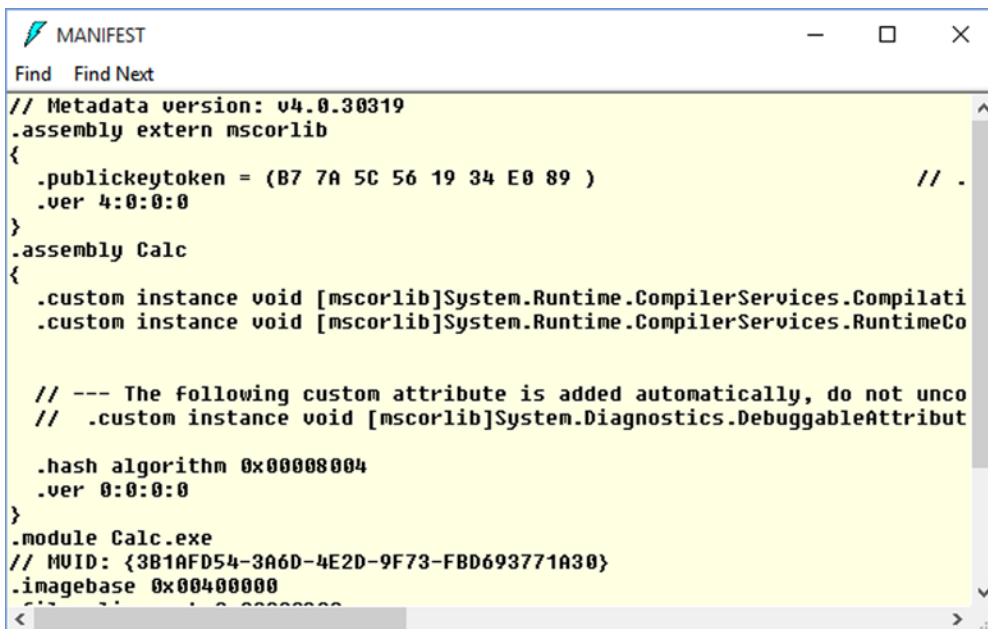

Figure 1-9. Viewing manifest data via ildasm.exe

To be sure, `ildasm.exe` has more options than shown here, and I will illustrate additional features of the tool where appropriate in the text.

The Platform-Independent Nature of .NET

Allow me to briefly comment on the platform-independent nature of the .NET platform. To the surprise of many developers, .NET applications can be developed and executed on non-Microsoft operating systems, including Mac OS X, various Linux distributions, Solaris, and iOS and Android mobile devices. To understand how this is possible, you need to come to terms with yet another abbreviation in the .NET universe: CLI (Common Language Infrastructure).

When Microsoft released the C# programming language and the .NET platform, it also crafted a set of formal documents that described the syntax and semantics of the C# and CIL languages, the .NET assembly format, core .NET namespaces, and the mechanics of the .NET runtime engine. These documents have been submitted to (and ratified by) Ecma International (www.ecma-international.org) as official international standards. The specifications of interest are as follows:

- *ECMA-334*: The C# Language Specification
- *ECMA-335*: The Common Language Infrastructure (CLI)

The importance of these documents becomes clear when you understand that they enable third parties to build distributions of the .NET platform for any number of operating systems and/or processors. ECMA-335 is the “meatier” of the two specifications, so much so that it has been broken into various partitions, including those shown in Table 1-4.

Table 1-4. Partitions of the CLI

| Partitions of ECMA-335 | Meaning in Life |
|---|--|
| Partition I: Concepts and Architecture | Describes the overall architecture of the CLI, including the rules of the CTS and CLS and the mechanics of the .NET runtime engine. |
| Partition II: Metadata Definition and Semantics | Describes the details of .NET metadata and the assembly format. |
| Partition III: CIL Instruction Set | Describes the syntax and semantics of CIL code. |
| Partition IV: Profiles and Libraries | Gives a high-level overview of the minimal and complete class libraries that must be supported by a .NET distribution. |
| Partition V: Binary Formats | Describes a standard way to interchange debugging information between CLI producers and consumers. |
| Partition VI: Annexes | Provides a collection of odds-and-ends details such as class library design guidelines and the implementation details of a CIL compiler. |

Be aware that Partition IV (Profiles and Libraries) defines only a *minimal* set of namespaces that represent the core services expected by a CLI distribution (e.g., collections, console I/O, file I/O, threading, reflection, network access, core security needs, XML data manipulation). The CLI does *not* define namespaces that facilitate web development (ASP.NET), database access (ADO.NET), or desktop graphical user interface (GUI) application development (Windows Presentation Foundation or Windows Forms).

The good news, however, is that the alternative .NET distribution (termed Mono) extends the CLI libraries with Microsoft-compatible equivalents of ASP.NET implementations, ADO.NET implementations, and various desktop GUI implementations to provide full-featured, production-level development platforms. To date, there are two major implementations of the CLI beyond Microsoft’s Windows-specific .NET platform. See Table 1-5.

Table 1-5. Open Source .NET Distributions

| Distribution | Meaning in Life |
|------------------|---|
| The Mono project | The Mono project is an open source distribution of the CLI that targets various Linux distributions (e.g., SuSe, Fedora), Mac OS X, iOS devices (iPad, iPhone), Android devices, and (surprise!) Windows. |
| .NET Core 5 | In addition to the Windows-Centric .NET Framework, Microsoft also supports a cross platform version of .NET, which focuses on the construction of code libraries and enterprise web applications. |

The Mono Project

The Mono project is an excellent choice if you want to build .NET software that can run on a variety of operating systems. In addition to all the key .NET namespaces, Mono provides additional libraries to allow the construction of GUI-based desktop software, ASP.NET web applications, and software-targeting mobile devices (iPad, iPhone, and Android). You can download the Mono distribution from the following URL:

www.mono-project.com/

Out of the box, the Mono project consists of a number of command-line tools and all of the associated code libraries. However, as you will see in Chapter 2, there is a full-fledged graphical IDE typically used with Mono named Xamarin Studio. In fact, Microsoft Visual Studio projects can be loaded into Xamarin Studio projects, and vice versa. Again, you can find more information in Chapter 2, but you might want to check out the Xamarin web site for more details.

<http://xamarin.com/>

■ **Note** Appendix B in your code download folder provides an overview of the Mono platform.

Microsoft .NET Core

The other major cross-platform distribution of .NET comes from Microsoft Corporation. Beginning in 2014, Microsoft announced an open source version of its full-scale (Windows specific) .NET 4.6 Framework called .NET Core. The .NET Core distribution is *not* a complete carbon copy of the .NET 4.6 Framework. Rather, .NET Core focuses on the construction of ASP.NET web applications that can run on Linux, Mac OS X, and Windows. Thus, you can essentially consider .NET Core to be a subset of the full .NET Framework. You can find a good article that compares and contrasts the full .NET Framework to the .NET Core framework on the MSDN .NET Blog site. Here is a direct link (but if this changes, just do a web search for *.NET Core is Open Source*):

<http://blogs.msdn.com/b/dotnet/archive/2014/11/12/net-core-is-open-source.aspx>

As luck would have it, all the features of C#, as well as a number of key libraries, are included in .NET Core. Therefore, a majority of this book will map directly to this distribution. Recall, though, that .NET Core is focused on building web applications and does not provide implementations of desktop GUI APIs (such as WPF or Windows Forms). If you need to build cross-platform desktop GUI applications, the Mono project is the better choice.

It is also worth noting that Microsoft has also released a free, light-weight, and cross-platform code editor to help support development with .NET Core. This editor is simply named Visual Studio Code. While it is certainly not as full featured as Microsoft Visual Studio or Xamarin Studio, it is a useful tool to edit C# code in a cross-platform manner. While this text will not use Visual Studio Code, you might want to learn more at the following web site:

<https://code.visualstudio.com/>

Summary

The point of this chapter was to lay out the conceptual framework necessary for the remainder of this book. I began by examining a number of limitations and complexities found within the technologies prior to .NET and followed up with an overview of how .NET and C# attempt to simplify the current state of affairs.

.NET basically boils down to a runtime execution engine (`mcoree.dll`) and base class library (`mcorlib.dll` and associates). The Common Language Runtime (CLR) is able to host any .NET binary (aka assembly) that abides by the rules of managed code. As you have seen, assemblies contain CIL instructions (in addition to type metadata and the assembly manifest) that are compiled to platform-specific instructions using a just-in-time (JIT) compiler. In addition, you explored the role of the Common Language Specification (CLS) and Common Type System (CTS). This was followed by an examination of the `ildasm.exe` object browsing tool.

In the next chapter, you will take a tour of the common integrated development environments (IDEs) you can use when you build your C# programming projects. You will be happy to know that in this book, I will use completely free (and very feature rich) IDEs, so you can start exploring the .NET universe with no money down.

CHAPTER 2



Building C# Applications

As a C# programmer, you can choose from among numerous tools to build .NET applications. The tool (or tools) you select will be based primarily on three factors: any associated costs, the OS you are using to develop the software, and the computing platforms you are targeting. The point of this chapter is to provide a survey of the most common integrated development environments (IDEs) that support the C# language. Do understand that this chapter will *not* go over every single detail of each IDE; it will give you enough information to select your programming environment as you work through this text and give you a foundation to build on.

The first part of this chapter will examine a set of IDEs from Microsoft that enable development of .NET applications on a Windows operating system (7, 8.x, and 10). As you will see, some of these IDEs can be used to build Windows-centric applications only, while others support the construction of C# apps for alternative operating systems and devices (such as Mac OS X, Linux, or Android). The latter part of this chapter will then examine some IDEs that can *run* on a non-Windows OS. This enables developers to build C# programs using Apple computers as well as Linux distributions.

■ **Note** This chapter will overview a good number of IDEs. However, this book will assume you are using the (completely free) Visual Studio Community Edition IDE. If you want to build your applications on a different OS (Mac OS X or Linux), this chapter will guide you in the right direction; however, your IDE will differ from the various screenshots in this text.

Building C# Applications on the Windows OS

As you will see over the course of this chapter, you can choose from a variety of IDEs to build C# applications; some come from Microsoft, and others come from third-party (many of which are open source) vendors. Now, despite what you might be thinking, many Microsoft IDEs are completely free. Thus, if your primary interest is to build .NET software on the Windows operating system (7, 8.x, or 10), you will find the following major options:

- Visual Studio Express
- Visual Studio Community
- Visual Studio Professional (or higher)

While these IDEs provide similar functionality, they differ primarily by the number of enterprise-level features and the number of supported project types. For example, the Express editions of Visual Studio lack some sophisticated database integration tools and specialized project templates for alternative .NET languages (such as F# and Python) that are included with Visual Studio 2015 Professional. The Visual Studio Community Edition supports the same project types as Visual Studio 2015 Professional, but it still lacks some features that would be most useful in a corporate development environment (such as full integration with Team Foundation Server). Thankfully, each IDE ships with sophisticated code editors, key database designers, integrated visual debuggers, GUI designers for desktop and web applications, and so forth. To begin, let's start by examining the role of the Express family of IDEs.

The Visual Studio Express Family of IDEs

The Visual Studio Express family of IDEs is completely free. In earlier versions of the .NET platform, the Express editions were partitioned by their supported .NET language; for example, previously Microsoft offered tools named C# Express, VB Express, Web Developer Express, and C++ Express. Recently, however, the Express family has been repartitioned based exclusively on the type of application you are interested in creating (web app, desktop app, etc.). Specifically, the Visual Studio Express family includes the following members:

- *Express for Windows Desktop*: Supports development of console-based and desktop GUI applications (Windows Forms and Windows Presentation Foundation) for the Windows OS. C#, VB, and C++ are supported.
- *Express for Windows 10*: Supports development for core software targeted for the Windows 10 “universal” application type that can run on multiple Microsoft devices (Windows OS, Xbox, Windows Mobile devices, HoloLens, and so on). C#, VB, and C++ are supported.
- *Express for Web*: Supports development for ASP.NET web applications, Azure cloud-based applications, and Microsoft Silverlight applications. C#, VB, and C++ are supported.
- *Team Foundation Server 2015 Express*: This version of the Express family is focused on providing a GUI interface to version code, create and process stories and tasks, and enable collaboration of software teams. Limited development tools are provided with this edition, and thus I won't comment on it further.

■ **Note** You can download the Express products from <https://www.visualstudio.com/products/visual-studio-express-vs> (or simply search for *Visual Studio Express* online).

The Express tools are useful to those of you who are new to .NET development in that they provide all the important features you would hope to find (visual GUI designers, debuggers, feature-rich code editors, etc.) but do not overwhelm you with dozens of auxiliary or advanced features that would only get in the way. To be sure, the Express tools can be a perfect fit for programming hobbyists or anybody wanting to use a “minimal but complete” IDE.

If you want, you could download the Express for Windows Desktop and Express for Web IDEs and work through this text successfully. Roughly speaking, Chapters 2–30 can be completed using Express for Windows Desktop, as I will be focusing on console apps, WPF apps, and an occasional Windows Forms app. The remainder of the book, which covers web application development (Chapters 31 onward), could use the Express for Web IDE, or Visual Studio Community Edition (examined later in this chapter).

Keep in mind that the Express IDEs, Visual Studio 2015 Community, and Visual Studio 2015 Professional all share a common core set of features. So, the good news is that it is easy to move between them and feel quite comfortable with their basic operation. Given this, let's dig a bit deeper into some of the Express IDEs (which, again, are all completely free).

A Brief Overview of Express for Windows Desktop

This version of the Express family allows you to build desktop applications that run directly on a Windows OS (version 7, 8.x, or Windows 10). To get your feet wet, let's take some time to build a simple C# application using Express for Windows Desktop and keep in mind that the topics illustrated here will be useful for all Microsoft IDEs.

The New Project Dialog Box and C# Code Editor

Assuming you have downloaded and installed this IDE, activate the File ► New Project menu option. As you can see in Figure 2-1, this IDE has support for console apps, WPF/Windows Forms apps, and some lower-level C++ project types. To start, create a new C# Console Application project named SimpleCSharpConsoleApp.

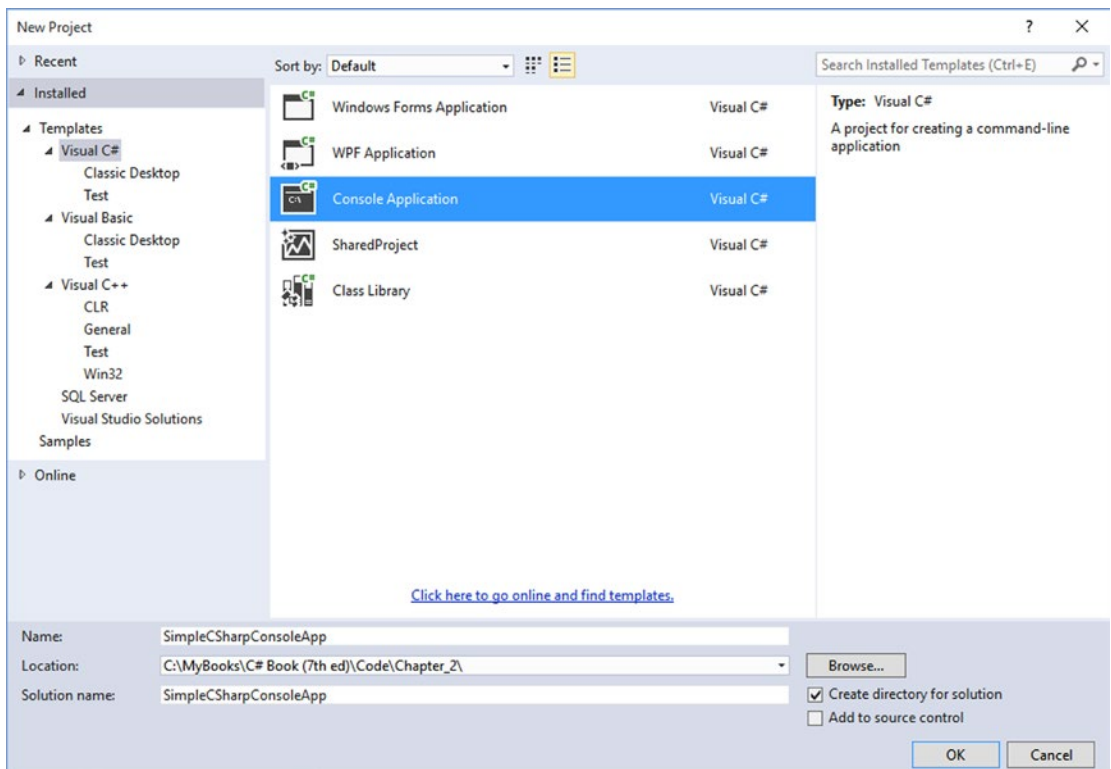

Figure 2-1. The New Project dialog box

Once the project has been created, you will see the initial C# code file (named `Program.cs`) has been opened in the code editor. Add the following C# code to your `Main()` method. You'll notice as you type that IntelliSense will kick in as you apply the dot operator.

```
static void Main(string[] args)
{
    // Set up Console UI (CUI)
    Console.Title = "My Rocking App";
    Console.ForegroundColor = ConsoleColor.Yellow;
    Console.BackgroundColor = ConsoleColor.Blue;
    Console.WriteLine("*****");
    Console.WriteLine("***** Welcome to My Rocking App *****");
    Console.WriteLine("*****");
    Console.BackgroundColor = ConsoleColor.Black;

    // Wait for Enter key to be pressed.
    Console.ReadLine();
}
```

Here, you are using the `Console` class defined in the `System` namespace. Because the `System` namespace has been automatically included at the top of your file via a `using` statement, you have no need to qualify the namespace before the class name (e.g., `System.Console.WriteLine()`). This program does not do anything too interesting; however, note the final call to `Console.ReadLine()`. This is in place simply to ensure the user must press a key to terminate the application. If you did not do this, the program would disappear almost instantly when debugging the program!

Running and Debugging your Project

Now, to run your program and see the output, you can simply press the `Ctrl+F5` keyboard command (which is also accessed from the `Debug` menu). Once you do, you will see a Windows console window pop on the screen with your custom (and colorful) message. Be aware that when you “run” your program, you bypass the integrated debugger.

If you need to debug your code (which will certainly be important when building larger programs), your first step is to set breakpoints at the code statement you want to examine. Although there isn't much code in this example, set a breakpoint by clicking the leftmost gray bar of the code editor (note that breakpoints are marked with a red dot icon; see [Figure 2-2](#)).

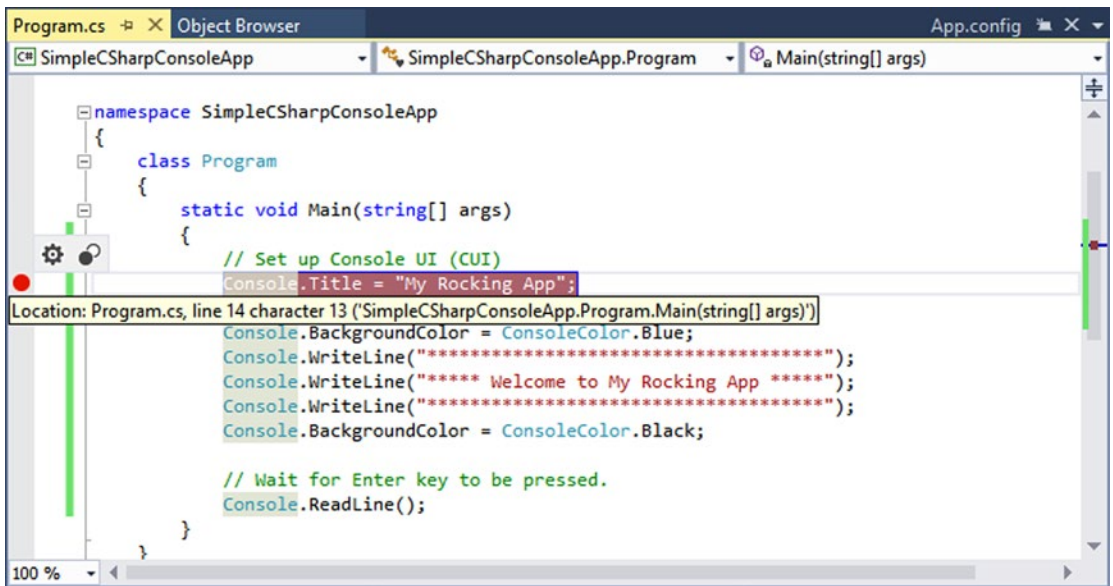

Figure 2-2. Setting breakpoints

If you now press the F5 key (or use the Debug menu), your program will halt at each breakpoint. As you would expect, you can interact with the debugger using the various toolbar buttons and menu options of the IDE. Once you have evaluated all breakpoints, the application will eventually terminate once `Main()` has completed.

■ **Note** Microsoft IDEs have sophisticated debuggers, and you will learn about various techniques over the chapters to come. For now, be aware that when you are in a debugging session, a large number of useful options will appear under the Debug menu. Take a moment to verify this for yourself.

The Solution Explorer

If you look at the right of the IDE, you will see a window named Solution Explorer, which shows you a few important things. First, notice that the IDE has created a solution with a single project (see Figure 2-3). This can be confusing at first, as they both have been given the same name (`SimpleCSharpConsoleApp`). The idea here is that a “solution” can contain multiple projects that all work together. For example, your solution might include three class libraries, one WPF application, and one WCF web service. The earlier chapters of this book will always have a single project; however, when you build some more complex examples, you’ll see how to add new projects to your initial solution space.

■ **Note** Be aware that when you select the topmost solution in the Solution Explorer window, the IDE’s menu system will show you a different set of choices than when you select a project. If you ever find yourself wondering where a certain menu item has disappeared to, double-check you did not accidentally select the wrong node.

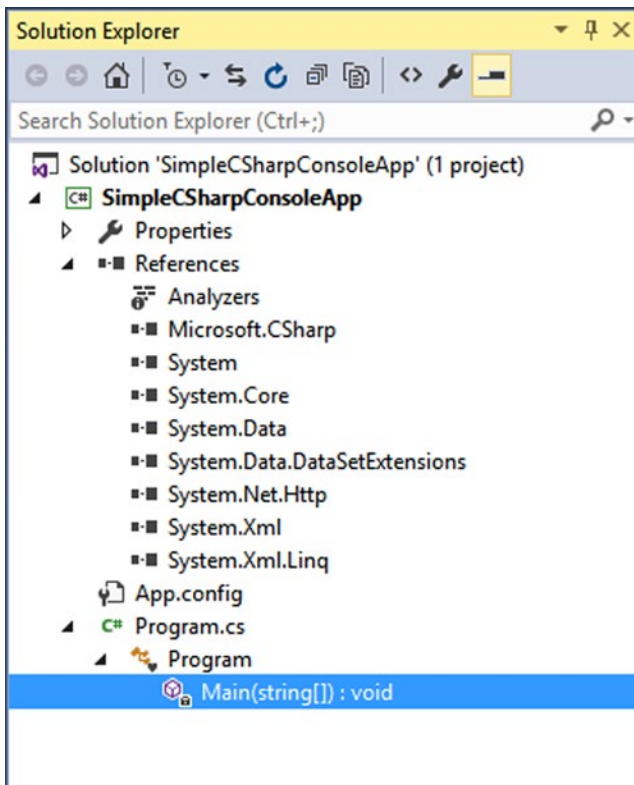

Figure 2-3. *The Solution Explorer*

You will also notice a References icon. You can use this node when your application needs to reference additional .NET libraries beyond what are included for a project type by default. Because you have created a C# Console Application project, you will notice a number of libraries have been automatically added such as System.dll, System.Core.dll, System.Data.dll, and so forth (note the items listed under the References node don't show the .dll file extension). You will see how to add libraries to a project shortly.

■ **Note** Recall from Chapter 1 that all .NET projects have access to a foundational library named `microsoftcorlib.dll`. This library is so necessary that it is not even listed explicitly in the Solution Explorer.

The Object Browser

If you were to double-click any library under the References node, you will open the integrated Object Browser (you can also open this using the View menu). Using this tool, you can see the various namespaces in an assembly, the types in a namespace, and the members of each type. Figure 2-4 shows some namespaces of the always-present `microsoft.dll` assembly.

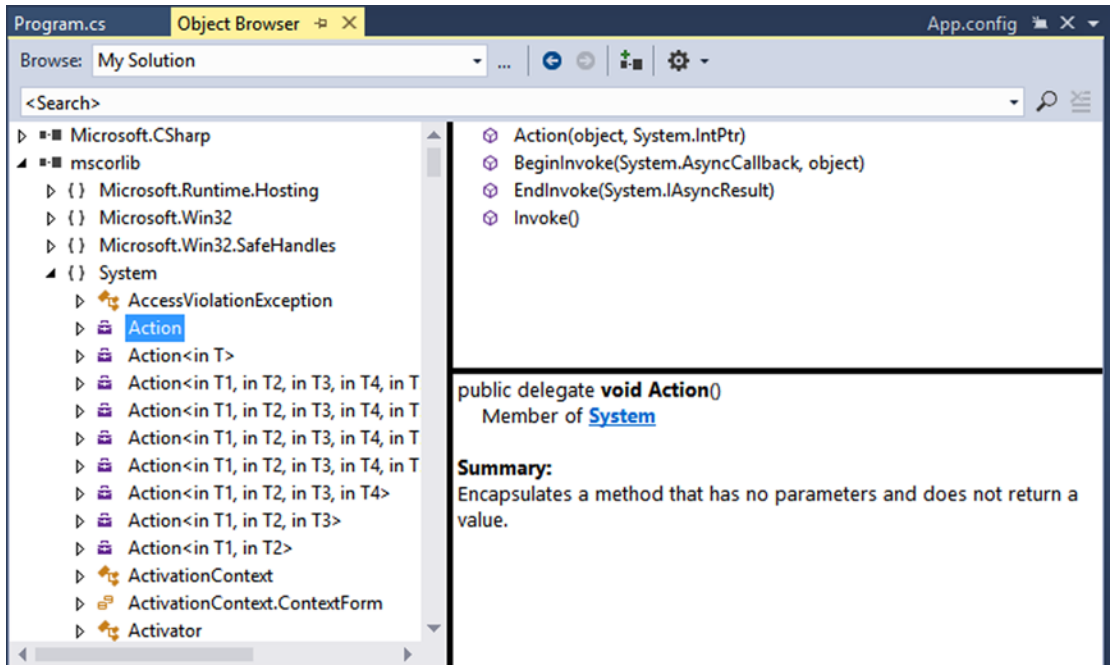

Figure 2-4. The Object Browser

This tool can be useful when you want to see the internal organization of a .NET library as well as when you want to get a brief description of a given item. Also notice the <Search> bar at the top of the window. This can be helpful when you know the name of a type you want to use but have no idea where it might be located. On a related note, keep in mind that the search feature will search only the libraries used in your current solution by default (you can search the entire .NET Framework by changing the selection in the Browse drop-down box).

Referencing Additional Assemblies

To continue your test, let's add an assembly (aka, code library) not automatically included in a Console Application project. To do so, right-click the References tab of the Solution Explorer and select Add Reference (or select the Project ► Add Reference menu option). From the resulting dialog box, find a library named `System.Windows.Forms.dll` (again, you won't see the file extension here) and check it off (Figure 2-5).

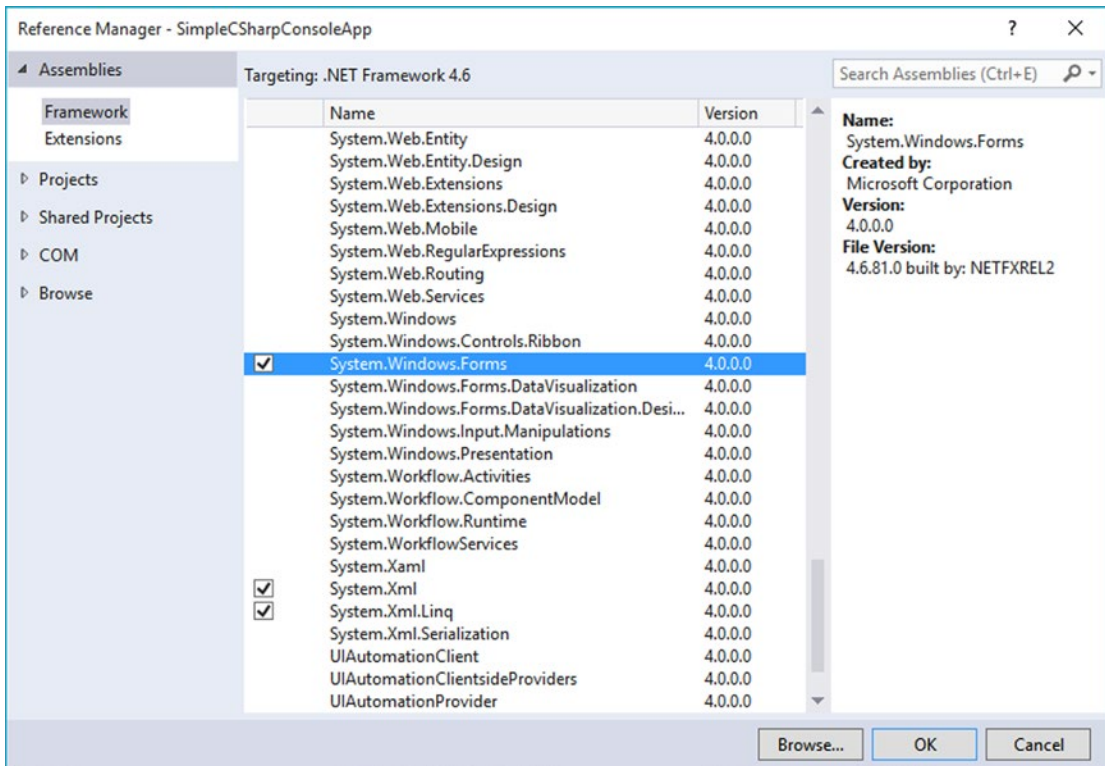

Figure 2-5. The Add Reference dialog

Once you click the OK button, this new library is added to your reference set (you'll see it listed under the References node). As explained in Chapter 1, however, referencing a library is only the first step. To use the types in a given C# code file, you need to define a using statement. Add the following line to the using directives in your code file:

```
using System.Windows.Forms;
```

And then add the following line of code directly after the call to `Console.ReadLine()` in your `Main()` method:

```
MessageBox.Show("All done!");
```

When you run or debug your program once again, you will find a simple message box appears before the program terminates.

Viewing Project Properties

Next, notice an icon named Properties within the Solution Explorer. When you double-click this item, you are presented with a sophisticated project configuration editor. For example, in Figure 2-6, notice how you can change the version of the .NET Framework you are targeting for the solution.

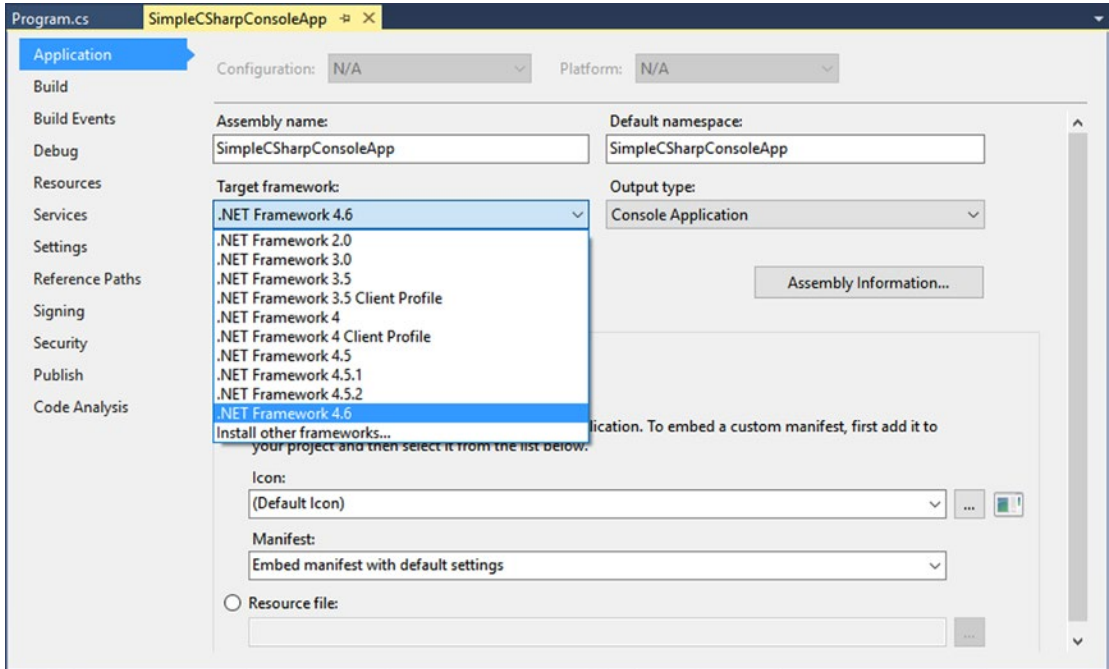

Figure 2-6. *The Project Properties window*

You will see various aspects of the Project Properties window as you progress through this book. However, if you take some time to poke around, you will see that you can establish various security settings, strongly name your assembly (see Chapter 14), deploy your application, insert application resources, and configure pre- and post-build events.

That wraps up the brief overview of Express for Windows Desktop. To be sure, this tool has many more features available than I have shown at this point. Recall that Visual Studio Community edition has the same core GUI as found in Express for Windows Desktop. You'll be introduced to other features that apply to either IDE as you progress through the book, but do take the time to tinker with menu options, dialog boxes, and property settings.

■ **Source Code** You can find the SimpleCSharpConsoleApp project in the Chapter 2 subdirectory.

A Brief Overview of Express for Web

If you want to build web applications with the .NET platform with the Express toolset, you can download and install the free Express for Web IDE. The final chapters of this text (Chapters 31–34) will dive into a number of important details regarding the construction of web apps under the .NET platform, so for now, simply check out Figure 2-7, which shows the types of projects you can create with this IDE via the New ► Project menu option.

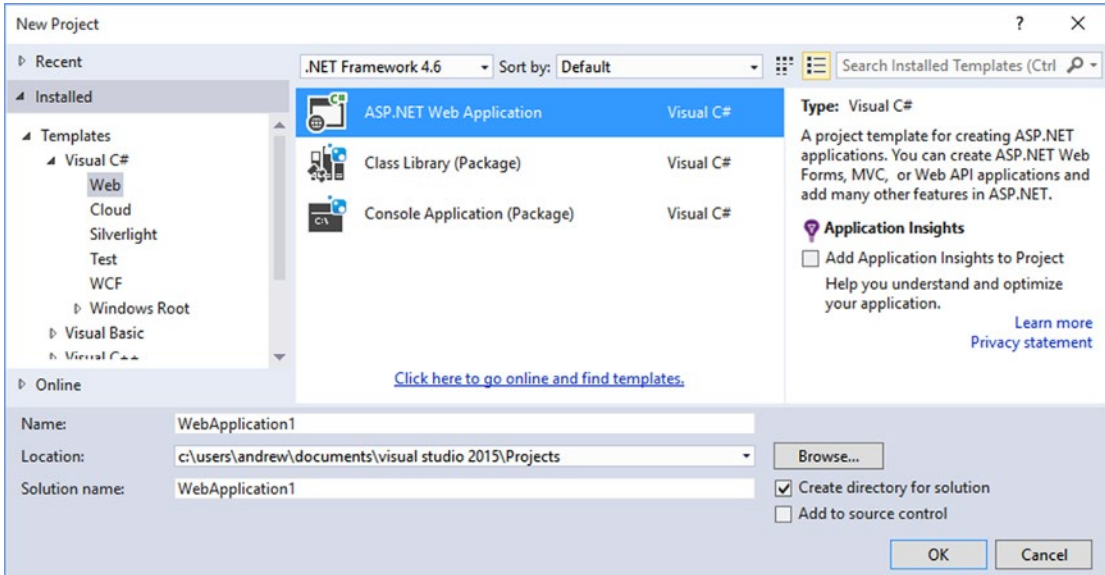

Figure 2-7. The Project Properties window of Express for Web

As you can see, Express for Web allows you to build ASP.NET web applications and Silverlight web GUIs and has support for Microsoft Azure Cloud services. Additionally, this IDE provides a WCF template to allow you to build service-oriented distributed solutions. Again, you will examine ASP.NET in the final chapters of this book.

That wraps up your quick overview of some of the members of the Express family. As mentioned, you will find that these tools provide “just enough” functionality for your coding efforts. Next up, let’s examine the role of Visual Studio Community.

The Visual Studio Community Edition IDE

Each of the Express tools is limited in that it allows you to build .NET software that will run only on the Windows OS (7, 8.x, or 10). However, as mentioned in Chapter 1, the .NET platform runs on a wide variety of operating systems and hardware devices. Thus, if you need to build a .NET program that can run on (for example) Android or an Apple product, the Express products won’t offer much help. As luck would have it, Microsoft offers another completely free IDE that allows you to build a much wider variety of project types using a larger number of .NET languages: the Visual Studio Community IDE.

■ **Note** You can download Visual Studio Community from <https://www.visualstudio.com/products/visual-studio-community-vs>.

The first thing to be aware of is that Visual Studio Community provides a single environment for building desktop *and* web apps (as well as “universal” .NET applications). Thus, unlike the Express family, there is no need to download multiple products.

As well, this IDE provides support for a number of additional programming languages (F#, Python, and JavaScript) and project types. Not only will you find more specialized Windows OS project types, but you will also find project types that target non-Microsoft platforms. Here are a few notable examples:

- Projects that target Windows Phone and Windows 8.x applications
- Projects that target Android devices
- Projects that target the iOS family (iPad, iPhone, and Apple Watch)
- Projects that target lower-level C++ APIs such as MFC and ATL
- Several project types that target the construction of video games on various devices
- Projects that allow you to extend Visual Studio Community (as well as Visual Studio Professional) with new functionality via extensibility plugins
- Projects to build custom PowerShell scripts

To get a better taste of all the language and project types provided by Visual Studio Community, take a look at Figure 2-8, which shows the New Project dialog of this IDE.

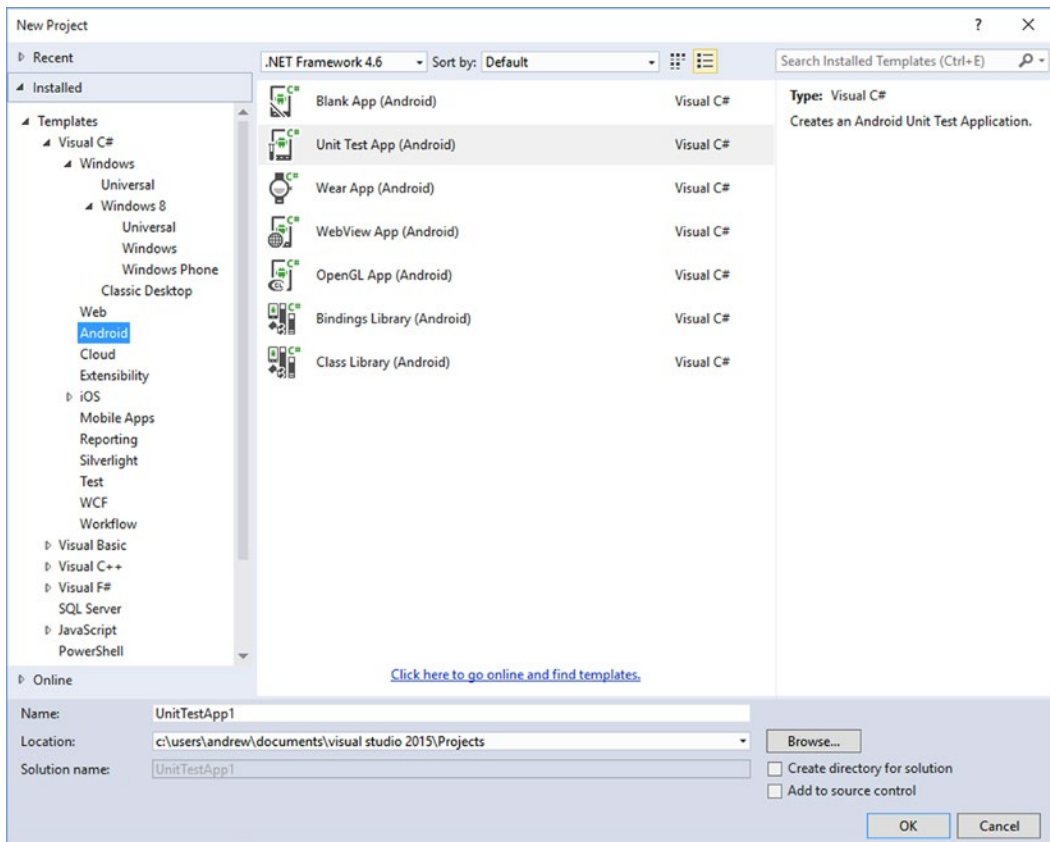

Figure 2-8. The New Project dialog of Visual Studio Community

The Visual Class Designer

Visual Studio Community also gives you the ability to design classes and other types (such as interfaces or delegates) in a visual manner (this functionality is not included in the Express IDEs). The Class Designer utility allows you to view and modify the relationships of the types (classes, interfaces, structures, enumerations, and delegates) in your project. Using this tool, you are able to visually add (or remove) members to (or from) a type and have your modifications reflected in the corresponding C# file. Also, as you modify a given C# file, changes are reflected in the class diagram.

Assuming you have installed Visual Studio Community, create a new C# Console Application project named VisualTypeDesignerApp. To access the visual type designer tools, the first step is to insert a new class diagram file. To do so, activate the Project ► Add New Item menu option and locate the Class Diagram type (Figure 2-9).

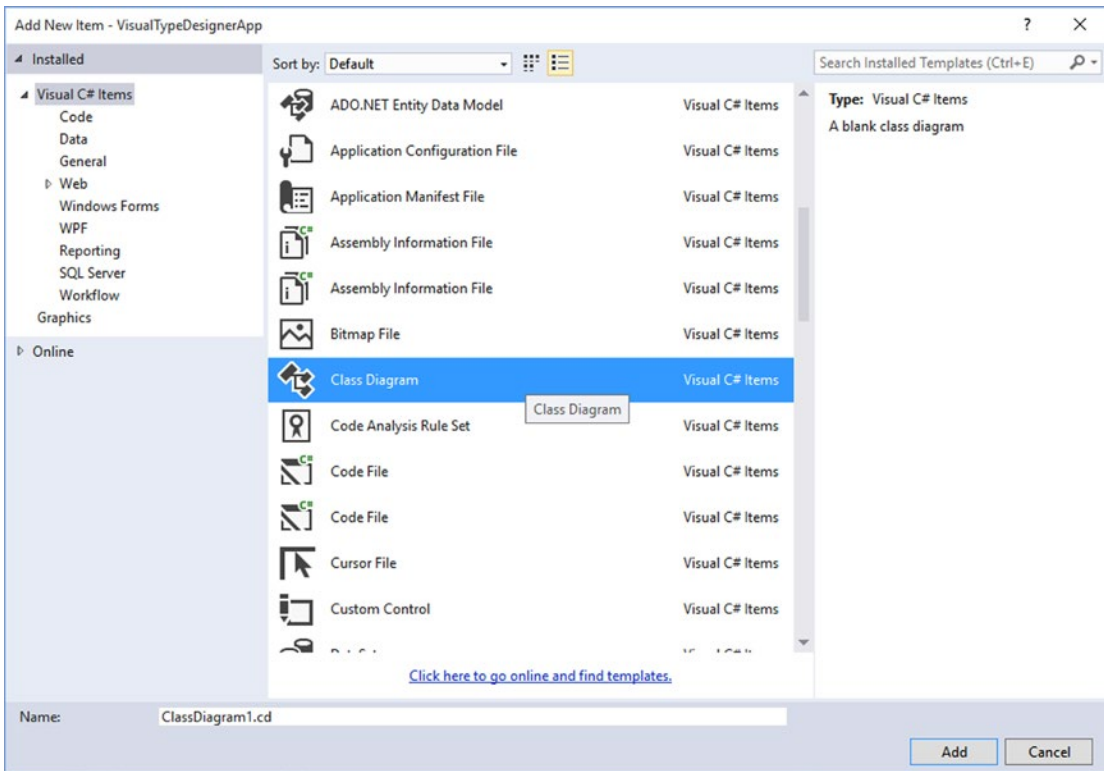

Figure 2-9. Inserting a class diagram file into the current project

Initially, the designer will be empty; however, you can drag and drop files from your Solution Explorer window on the surface. For example, once you drag Program.cs onto the designer, you will find a visual representation of the Program class. If you click the arrow icon for a given type, you can show or hide the type’s members (see Figure 2-10).

■ **Note** Using the Class Designer toolbar, you can fine-tune the display options of the designer surface.

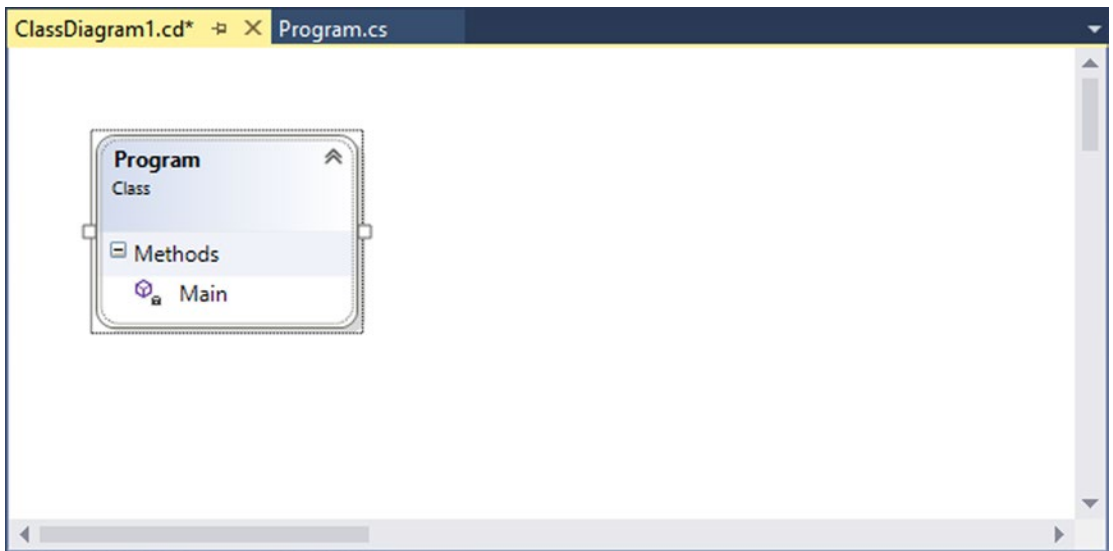

Figure 2-10. The Class Diagram viewer

The Class Designer utility works in conjunction with two other aspects of Visual Studio: the Class Details window (activated using the View ► Other Windows menu) and the Class Designer Toolbox (activated using the View ► Toolbox menu item). The Class Details window not only shows you the details of the currently selected item in the diagram but also allows you to modify existing members and insert new members on the fly (see Figure 2-11).

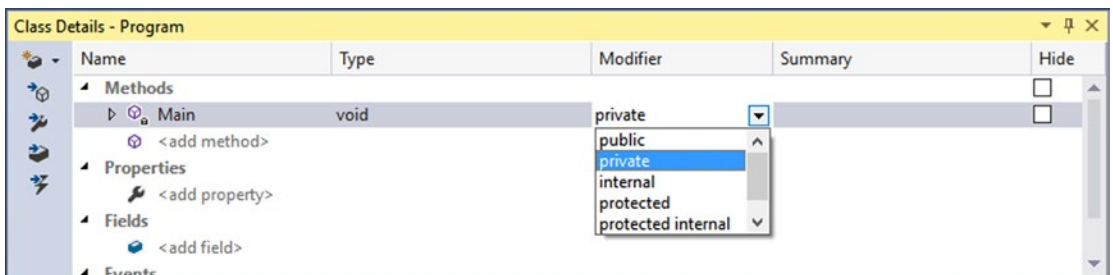

Figure 2-11. The Class Details window

The Class Designer Toolbox, which can also be activated using the View menu, allows you to insert new types (and create relationships between these types) into your project visually (see Figure 2-12). (Be aware you must have a class diagram as the active window to view this toolbox.) As you do so, the IDE automatically creates new C# type definitions in the background.

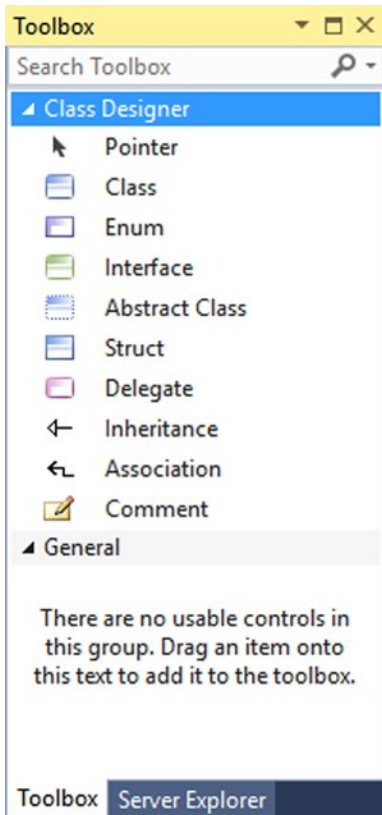

Figure 2-12. *The Class Designer Toolbox*

By way of example, drag a new class from the Class Designer Toolbox onto your Class Designer. Name this class `Car` in the resulting dialog box. This will result in the creation of a new C# file named `Car.cs` that is automatically added to your project. Now, using the Class Details window, add a public `string` field named `petName` (see Figure 2-13).

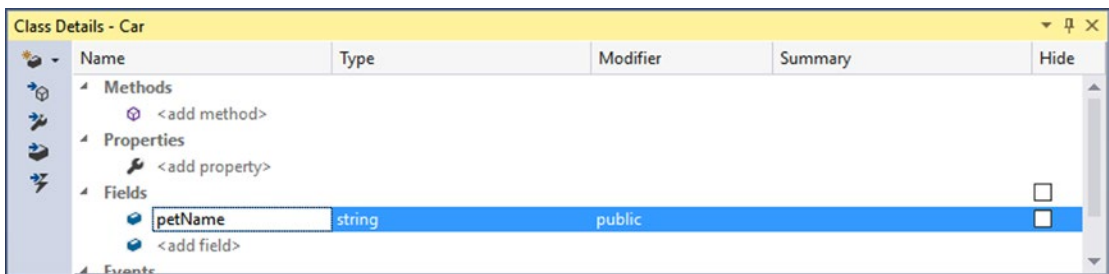

Figure 2-13. *Adding a field with the Class Details window*

If you now look at the C# definition of the Car class, you will see it has been updated accordingly (minus the additional code comments shown here).

```
public class Car
{
    // Public data is typically a bad idea; however,
    // it keeps this example simple.
    public string petName;
}
```

Now, activate the designer file once again and drag another new class onto the designer and name it SportsCar. Select the Inheritance icon from the Class Designer Toolbox and click the top of the SportsCar icon. Next, click the mouse on top of the Car class icon. If you performed these steps correctly, you have just derived the SportsCar class from Car (see Figure 2-14).

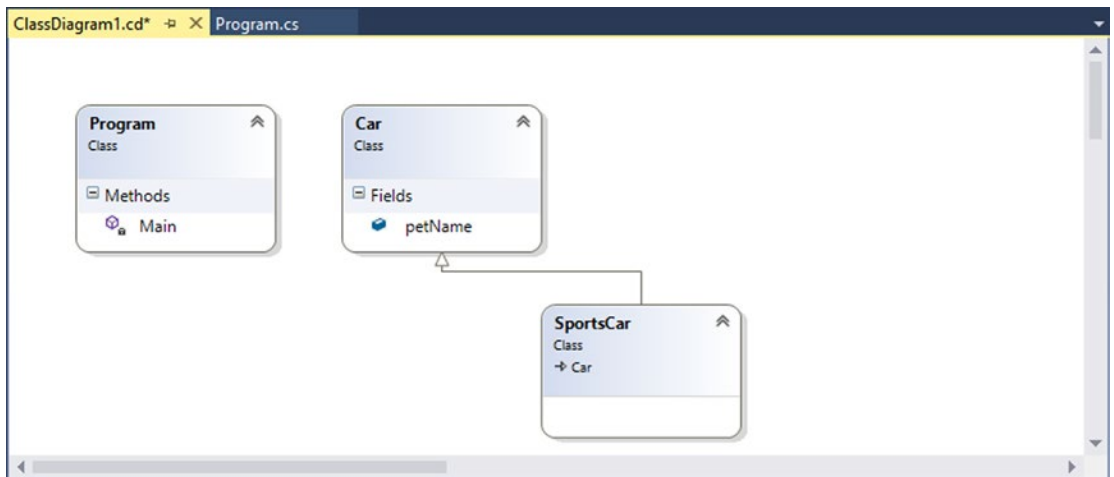

Figure 2-14. Visually deriving from an existing class

■ **Note** The concept of inheritance will be fully examined in Chapter 6.

To complete this example, update the generated SportsCar class with a public method named GetPetName(), authored as follows:

```
public class SportsCar : Car
{
    public string GetPetName()
    {
        petName = "Fred";
        return petName;
    }
}
```

As you would expect, the visual type designer is one of the many features of Visual Studio Community. As mentioned earlier, this edition of the book will assume you are using Visual Studio Community as your IDE of choice. Over the chapters to come, you will learn many more features of this tool.

■ **Source Code** You can find the `VisualTypeDesignerApp` project in the [Chapter 2](#) subdirectory.

The Visual Studio 2015 Professional IDE

To wrap up your examination of IDEs that run exclusively on the Windows OS, let's take a quick look at Visual Studio 2015 Professional. If you are currently employed as a software engineer, the chances are good your company has purchased a copy of this IDE for you as your tool of choice. Visual Studio 2015 Professional has all the same features found in Visual Studio Community (the same project types, same language choices, and same visual designers). In addition, this IDE has a number of features geared toward corporate-level collaborative development. By way of a few examples, with Visual Studio Professional you have the following:

- Integration with Team Foundation Server (TFS) to manage Agile and Kanban boards
- Tools to create and manage stories, tasks, and epics
- SharePoint integration and developer chat rooms
- Tools to manage sprint planning

To be sure, diving into the details of the software development life cycle is beyond the scope of this book. Given this, I won't be saying much more about Visual Studio 2015 Professional. If you choose to use this IDE, that is perfectly fine. Remember, the functionality of Community and Professional is identical beyond these team-centric development tools.

■ **Note** You can find a side-by-side comparison of Community vs. Professional online at <https://www.visualstudio.com/products/compare-visual-studio-2015-products-vs>.

The .NET Framework Documentation System

The final aspect of Visual Studio you *must* be comfortable with from the outset is the fully integrated help system. The .NET Framework documentation is extremely good, very readable, and full of useful information. Given the huge number of predefined .NET types (which number well into the thousands), you must be willing to roll up your sleeves and dig into the provided documentation. If you resist, you are doomed to a long, frustrating, and painful existence as a .NET developer.

If you have an Internet connection, you can view the .NET Framework SDK documentation online at the following web address:

<http://msdn.microsoft.com/library>

Once you are on this main page, locate the Development Tools and Languages section of the page and click “.NET Framework class library.” From here, click the “.NET Framework class library” link for the version of the framework you are interested in (which I will assume is 4.6). At this point, you can use the tree navigation window to view each namespace, type, and member of the platform. See Figure 2-15 for an example of viewing the types of the System namespace.

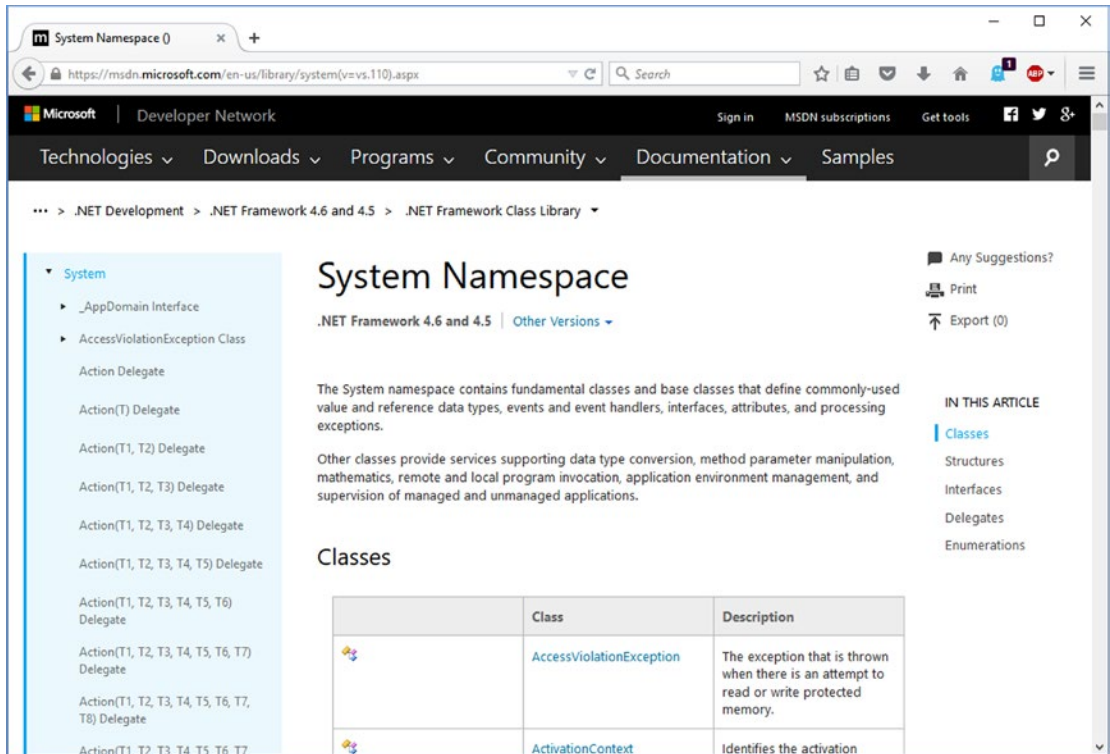

Figure 2-15. Viewing the .NET Framework documentation online

■ **Note** It would not be surprising if Microsoft someday changes the location of the online .NET Framework Class Library documentation. If this is the case, a web search for the same topic (*.NET Framework Class Library documentation*) should quickly help you find the current location.

In addition to the online documentation, Visual Studio provides the option to install the same help system locally to your computer (which can be helpful when you don't have an active Internet connection). If you want to perform a local installation of the help system after installing Visual Studio Community, access the Help ► Add and Remove Help Content menu option. From here, you can select each of the help systems you want to install locally (if hard drive space allows, I recommend adding all possible documentation). See Figure 2-16.

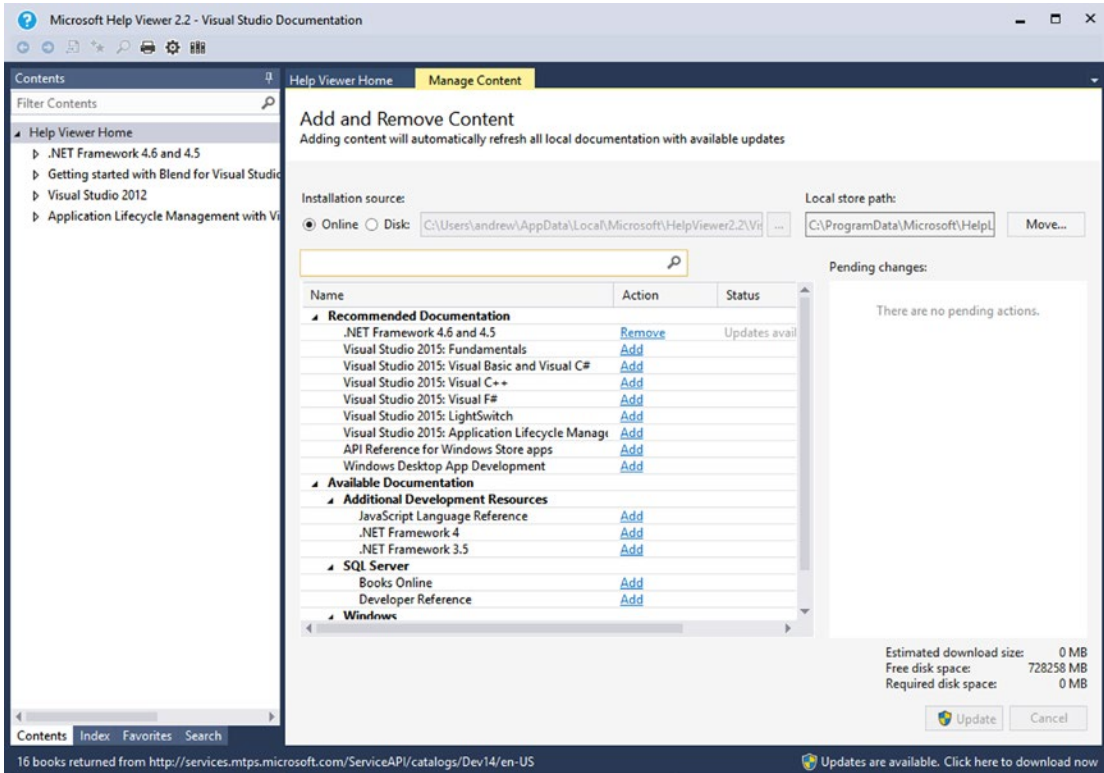

Figure 2-16. Installing a local help system

Once you have installed all the documentation, you can launch the help viewer application (as well as set up how you want Visual Studio to display help [locally or online]) using the Help menu. As well, an even easier way to interact with the documentation is to highlight a C# keyword, type the name or member name within the Visual Studio code window, and press the F1 key. This will automatically open a documentation window for the selected item. For example, select the string keyword within your Car class definition. After you press F1, you will see the help page for the string type appear.

Another useful aspect of the documentation is the Search tab of the display. Here you can enter in the name of any namespace, type, or member and navigate to the correct location. If you were to try to search for the System.Reflection namespace, you would be able to learn about the details of this namespace, examine the contained types, view code examples, and so forth.

■ **Note** At the risk of sounding like a broken record, I really can't emphasize enough how important it is that you learn to use the .NET Framework SDK documentation. No book, no matter how lengthy, can cover every aspect of the .NET platform. Make sure you take some time to get comfortable using the help system—you'll thank yourself later.

Building .NET Applications Beyond the Windows OS

The members of the Microsoft Visual Studio family are powerful and quite sophisticated. Indeed, if your primary (if not your only) interest is to build .NET programs on a Windows machine and run them on a Windows machine, then Visual Studio will most likely be the only IDE you will need. Recall from Chapter 1, however, the .NET platform can run on a variety of operating systems. Given this, allow me to point out a key cross-platform IDE.

The Role of Xamarin Studio

Chapter 1 mentioned the role of the Mono platform. Recall that this cross-platform implementation of .NET ships with numerous command-line tools to build your software. While you could build a full-scale .NET program using a simple text editor and the command-line C# compiler, this would quickly become quite cumbersome!

Xamarin Studio is a free .NET IDE that runs on Windows, Mac OS X, and Linux. It is similar to Visual Studio Community in that it supports a variety of programming languages (including C#) and provides feature-rich code editors and visual debuggers and GUI designers. If you intend to build your .NET software on a non-Microsoft operating system, this IDE is sure to be your tool of choice. You can download (and read up on) this tool from the following URL:

<http://xamarin.com/>

■ **Note** It is perfectly fine to install Xamarin Studio on a machine that also has installed Visual Studio Community. However, be sure to shut down the Visual Studio IDE before installing Xamarin Studio to ensure a smooth installation.

Once you have installed this IDE, you can create a new project via the File ► New ► Solution menu option. Here, you can select from a variety of templates and select your programming language of choice. In Figure 2-17, you can see the now-familiar C# Console Application type.

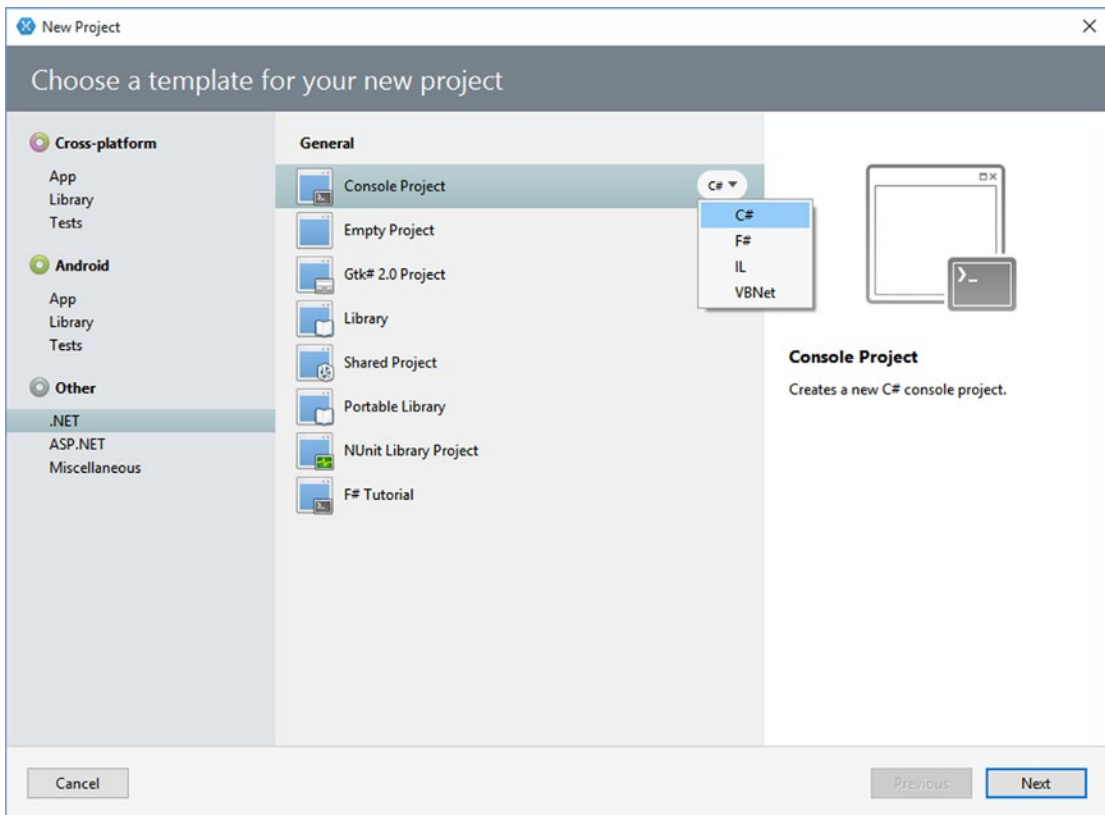

Figure 2-17. *Creating a new solution in Xamarin Studio*

Once you create a new project, you should find the basics of this IDE fairly familiar given your exploration of the Visual Studio IDEs examined thus far. In Figure 2-18, you can see IntelliSense and project navigation are alive and well.

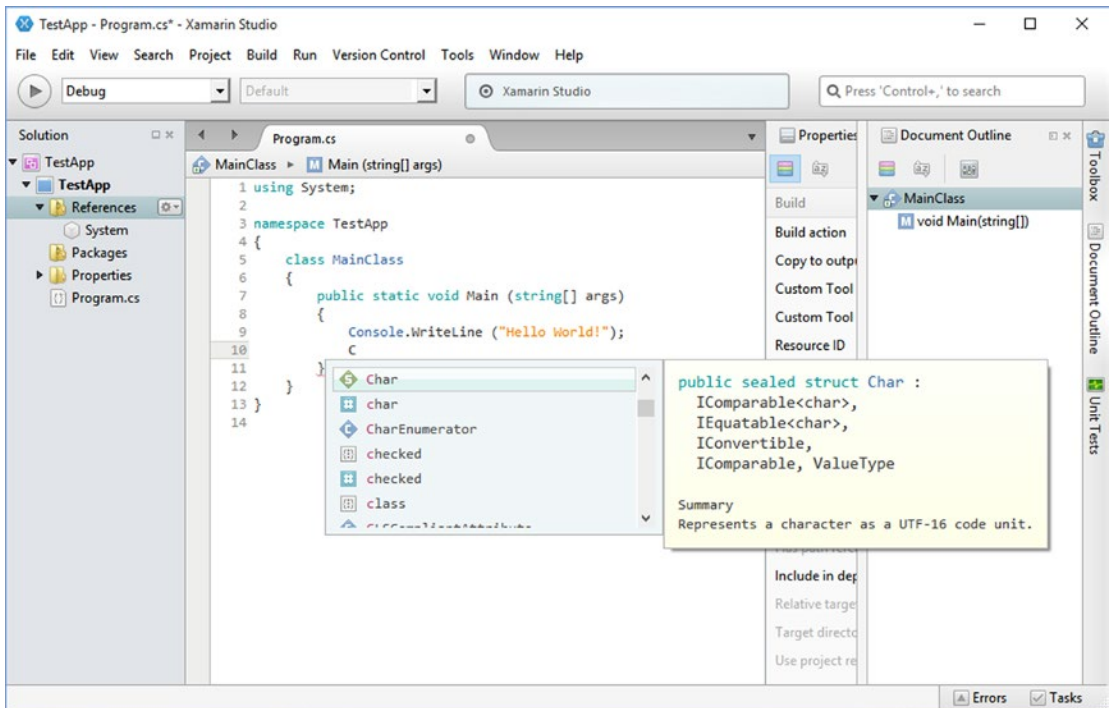

Figure 2-18. The Xamarin Studio code editor

Because Xamarin Studio is able to run on non-Microsoft operating systems, it should not be too surprising that if this IDE is used on Mac OS X or Linux, it will be using the Mono runtime and Mono toolset. However, Xamarin Studio can also run just fine on the Windows OS. Given this, you are able to compile your C# code against either the Microsoft .NET platform or the Mono platform (provided you have indeed installed Mono). To select your platform target, use the Tools ► Options menu option and then select .NET Runtimes (see Figure 2-19).

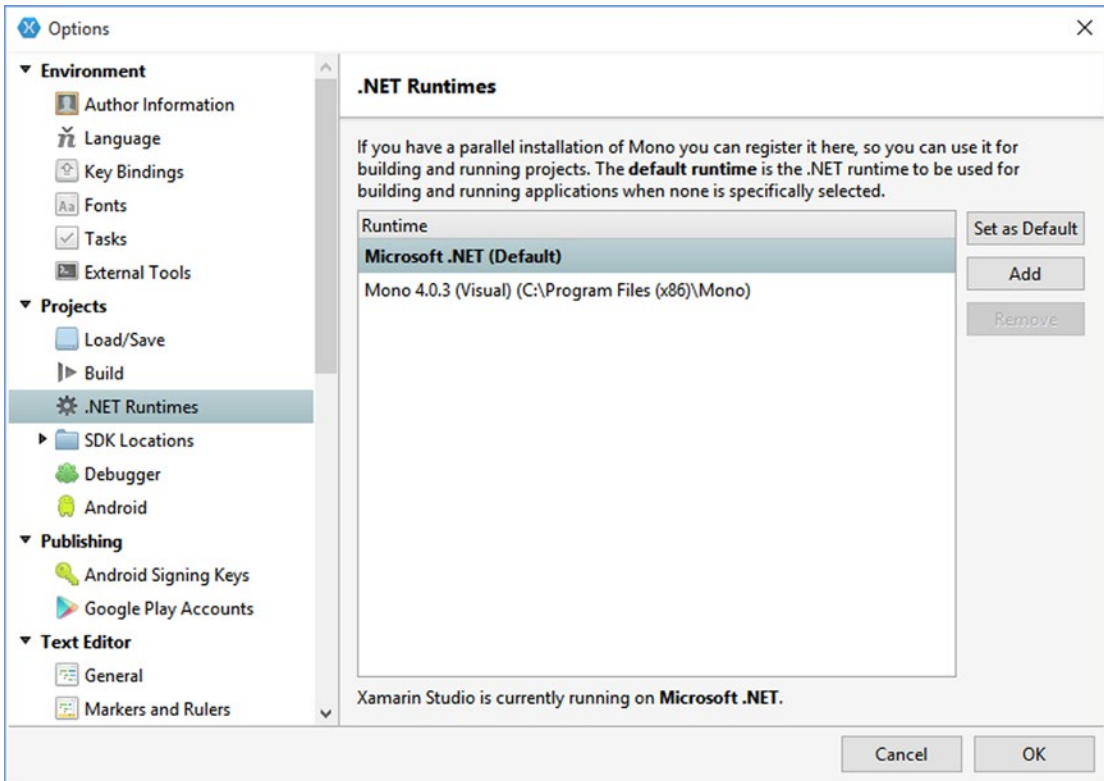

Figure 2-19. Selecting a .NET runtime in Xamarin Studio

Although I will not be using Xamarin Studio in this book, you will be happy to know that a majority of the coding projects created over the text will work perfectly on non-Microsoft systems. Thus, if you want to work through the material using Mac OS X or Linux, you will be able to do so fairly cleanly. Do be aware, however, that the Mono platform does not support the Windows Presentation Foundation (WPF) APIs, so you would be unable to build WPF apps on a non-Microsoft OS. However, Mono does offer support for a majority of the APIs used in this book (you'll have no problem going through Chapters 3-24 and most of the web development content).

■ **Note** See the Mono documentation (www.mono-project.com/docs/) for full details regarding which aspects of Microsoft .NET are fully supported.

Summary

As you can see, you have many new toys at your disposal! The point of this chapter was to provide you with a tour of the major programming tools a C# programmer may leverage during the development process. As mentioned, if you are interested only in building .NET applications on a Windows development machine, your best bet is to download Visual Studio Community Edition. As also mentioned, this edition of the book will use this particular IDE going forward. Thus, the forthcoming screenshots, menu options, and visual designers will all assume you are using Visual Studio Community.

If you want to build .NET applications using the Mono platform or want to build your software on a non-Windows OS, Xamarin Studio will be your best choice. While this IDE is not identical to Visual Studio Community, you should have little problem using this tool during a majority of the book. With this, Chapter 3 will begin your examination of the C# programming language.

PART II



Core C# Programming

CHAPTER 3



Core C# Programming Constructs, Part I

This chapter begins your formal investigation of the C# programming language by presenting a number of bite-sized, stand-alone topics you must be comfortable with as you explore the .NET Framework. The first order of business is to understand how to build your program's *application object* and to examine the composition of an executable program's entry point: the `Main()` method. Next, you will investigate the fundamental C# data types (and their equivalent types in the `System` namespace) including an examination of the `System.String` and `System.Text.StringBuilder` classes.

After you know the details of the fundamental .NET data types, you will then examine a number of data type conversion techniques, including narrowing operations, widening operations, and the use of the checked and unchecked keywords.

This chapter will also examine the role of the C# `var` keyword, which allows you to *implicitly* define a local variable. As you will see later in this book, implicit typing is extremely helpful, if not occasionally mandatory, when working with the LINQ technology set. You will wrap up this chapter by quickly examining the C# keywords and operators that allow you to control the flow of an application using various looping and decision constructs.

The Anatomy of a Simple C# Program

C# demands that all program logic be contained within a type definition (recall from Chapter 1 that *type* is a general term referring to a member of the set {class, interface, structure, enumeration, delegate}). Unlike many other languages, in C# it is not possible to create global functions or global points of data. Rather, all data members and all methods must be contained within a type definition. To get the ball rolling, create a new Console Application project named `SimpleCSharpApp`. You might agree that the code within the initial `Program.cs` file is rather uneventful.

```
using System;
using System.Collections.Generic;
using System.Linq;
using System.Text;
using System.Threading.Tasks;
```

```
namespace SimpleCSharpApp
{
    class Program
    {
        static void Main(string[] args)
        {
        }
    }
}
```

Given this, update the `Main()` method of your `Program` class with the following code statements:

```
class Program
{
    static void Main(string[] args)
    {
        // Display a simple message to the user.
        Console.WriteLine("***** My First C# App *****");
        Console.WriteLine("Hello World!");
        Console.WriteLine();

        // Wait for Enter key to be pressed before shutting down.
        Console.ReadLine();
    }
}
```

■ **Note** C# is a case-sensitive programming language. Therefore, *Main* is not the same as *main*, and *Readline* is not the same as *ReadLine*. Be aware that all C# keywords are lowercase (e.g., `public`, `lock`, `class`, `dynamic`), while namespaces, types, and member names begin (by convention) with an initial capital letter and have capitalized the first letter of any embedded words (e.g., `Console.WriteLine`, `System.Windows.MessageBox`, `System.Data.SqlClient`). As a rule of thumb, whenever you receive a compiler error regarding “undefined symbols,” be sure to check your spelling and casing first!

The previous code contains a definition for a class type that supports a single method named `Main()`. By default, Visual Studio names the class defining `Main()` `Program`; however, you are free to change this if you so choose. Every executable C# application (console program, Windows desktop program, or Windows service) must contain a class defining a `Main()` method, which is used to signify the entry point of the application.

Formally speaking, the class that defines the `Main()` method is termed the *application object*. While it is possible for a single executable application to have more than one application object (which can be useful when performing unit tests), you must inform the compiler which `Main()` method should be used as the entry point via the `/main` option of the command-line compiler or via the Startup Object drop-down list box, located on the Application tab of the Visual Studio project properties editor (see Chapter 2).

Note that the signature of `Main()` is adorned with the `static` keyword, which will be examined in detail in Chapter 5. For the time being, simply understand that static members are scoped to the class level (rather than the object level) and can thus be invoked without the need to first create a new class instance.

In addition to the `static` keyword, this `Main()` method has a single parameter, which happens to be an array of strings (`string[] args`). Although you are not currently bothering to process this array, this parameter may contain any number of incoming command-line arguments (you'll see how to access them momentarily). Finally, this `Main()` method has been set up with a `void` return value, meaning you do not explicitly define a return value using the `return` keyword before exiting the method scope.

The logic of `Program` is within `Main()`. Here, you make use of the `Console` class, which is defined within the `System` namespace. Among its set of members is the static `WriteLine()`, which, as you might assume, sends a text string and carriage return to the standard output. You also make a call to `Console.ReadLine()` to ensure the command prompt launched by the Visual Studio IDE remains visible during a debugging session until you press the Enter key. (If you did not add this line, your application would terminate immediately during a debugging session and you could not read the output!) You will learn more about the `System.Console` class shortly.

Variations on the `Main()` Method

By default, Visual Studio will generate a `Main()` method that has a `void` return value and an array of `string` types as the single input parameter. This is not the only possible form of `Main()`, however. It is permissible to construct your application's entry point using any of the following signatures (assuming it is contained within a C# class or structure definition):

```
// int return type, array of strings as the parameter.
static int Main(string[] args)
{
    // Must return a value before exiting!
    return 0;
}
```

```
// No return type, no parameters.
static void Main()
{
}
```

```
// int return type, no parameters.
static int Main()
{
    // Must return a value before exiting!
    return 0;
}
```

■ **Note** The `Main()` method may also be defined as `public` as opposed to `private`, which is assumed if you do not supply a specific access modifier. Visual Studio automatically defines a program's `Main()` method as implicitly `private`.

Obviously, your choice of how to construct `Main()` will be based on two questions. First, do you want to return a value to the system when `Main()` has completed and your program terminates? If so, you need to return an `int` data type rather than `void`. Second, do you need to process any user-supplied, command-line parameters? If so, they will be stored in the array of `strings`. Let's examine all of the options in more detail.

Specifying an Application Error Code

While a vast majority of your `Main()` methods will return `void` as the return value, the ability to return an `int` from `Main()` keeps C# consistent with other C-based languages. By convention, returning the value 0 indicates the program has terminated successfully, while another value (such as -1) represents an error condition (be aware that the value 0 is automatically returned, even if you construct a `Main()` method prototyped to return `void`).

On the Windows operating system, an application's return value is stored within a system environment variable named `%ERRORLEVEL%`. If you were to create an application that programmatically launches another executable (a topic examined in Chapter 18), you can obtain the value of `%ERRORLEVEL%` using the static `System.Diagnostics.Process.ExitCode` property.

Given that an application's return value is passed to the system at the time the application terminates, it is obviously not possible for an application to obtain and display its final error code while running. However, to illustrate how to view this error level upon program termination, begin by updating the `Main()` method, as follows:

```
// Note we are now returning an int, rather than void.
static int Main(string[] args)
{
    // Display a message and wait for Enter key to be pressed.
    Console.WriteLine("***** My First C# App *****");
    Console.WriteLine("Hello World!");
    Console.WriteLine();
    Console.ReadLine();

    // Return an arbitrary error code.
    return -1;
}
```

Now let's capture the return value of `Main()` with the help of a batch file. Using Windows Explorer, navigate to the folder containing your compiled application (for example, `C:\SimpleCSharpApp\bin\Debug`). Add a new text file (named `SimpleCSharpApp.bat`) to the `Debug` folder that contains the following instructions (if you have not authored *.bat files before, don't concern yourself with the details; this is a test... this is only a test):

```
@echo off

rem A batch file for SimpleCSharpApp.exe
rem which captures the app's return value.

SimpleCSharpApp
@if "%ERRORLEVEL%" == "0" goto success

:fail
    echo This application has failed!
    echo return value = %ERRORLEVEL%
    goto end
:success
    echo This application has succeeded!
    echo return value = %ERRORLEVEL%
    goto end
:end
echo All Done.
```

At this point, open a command prompt and navigate to the folder containing your executable and new *.bat file. Execute the batch logic by typing its name and pressing the Enter key. You should find the output shown next, given that your `Main()` method is returning -1. Had the `Main()` method returned 0, you would see the message “This application has succeeded!” print to the console.

```
***** My First C# App *****
Hello World!

This application has failed!
return value = -1
All Done.
```

Again, a vast majority (if not all) of your C# applications will use `void` as the return value from `Main()`, which, as you recall, implicitly returns the error code of zero. To this end, the `Main()` methods used in this text (beyond the current example) will indeed return `void` (and the remaining projects will certainly not need to make use of batch files to capture return codes).

Processing Command-Line Arguments

Now that you better understand the return value of the `Main()` method, let's examine the incoming array of string data. Assume that you now want to update your application to process any possible command-line parameters. One way to do so is using a C# `for` loop. (Note that C#'s iteration constructs will be examined in some detail near the end of this chapter.)

```
static int Main(string[] args)
{
    ...
    // Process any incoming args.
    for(int i = 0; i < args.Length; i++)
        Console.WriteLine("Arg: {0}", args[i]);

    Console.ReadLine();
    return -1;
}
```

Here, you are checking to see whether the array of strings contains some number of items using the `Length` property of `System.Array`. As you'll see in Chapter 4, all C# arrays actually alias the `System.Array` class and, therefore, share a common set of members. As you loop over each item in the array, its value is printed to the console window. Supplying the arguments at the command line is equally simple, as shown here:

```
C:\SimpleCSharpApp\bin\Debug>SimpleCSharpApp.exe /arg1 -arg2

***** My First C# App *****
Hello World!
Arg: /arg1
Arg: -arg2
```

As an alternative to the standard `for` loop, you may iterate over an incoming `string` array using the C# `foreach` keyword. Here is some sample usage (but again, you will see specifics of looping constructs later in this chapter):

```
// Notice you have no need to check the size of the array when using "foreach".
static int Main(string[] args)
{
    ...
    // Process any incoming args using foreach.
    foreach(string arg in args)
        Console.WriteLine("Arg: {0}", arg);

    Console.ReadLine();
    return -1;
}
```

Finally, you are also able to access command-line arguments using the static `GetCommandLineArgs()` method of the `System.Environment` type. The return value of this method is an array of `strings`. The first index identifies the name of the application itself, while the remaining elements in the array contain the individual command-line arguments. Note that when using this approach, it is no longer necessary to define `Main()` as taking a `string` array as the input parameter, although there is no harm in doing so.

```
static int Main(string[] args)
{
    ...
    // Get arguments using System.Environment.
    string[] theArgs = Environment.GetCommandLineArgs();
    foreach(string arg in theArgs)
        Console.WriteLine("Arg: {0}", arg);

    Console.ReadLine();
    return -1;
}
```

Of course, it is up to you to determine which command-line arguments your program will respond to (if any) and how they must be formatted (such as with a `-` or `/` prefix). Here, I simply passed in a series of options that were printed directly to the command prompt. Assume, however, you were creating a new video game and programmed your application to process an option named `-godmode`. If the user starts your application with the flag, you know he is, in fact, *a cheater*, and you can take an appropriate course of action.

Specifying Command-Line Arguments with Visual Studio

In the real world, an end user has the option of supplying command-line arguments when starting a program. However, during the development cycle, you might want to specify possible command-line flags for testing purposes. To do so with Visual Studio, double-click the Properties icon in Solution Explorer and select the Debug tab on the left side. From there, specify values using the command-line arguments text box (see Figure 3-1) and save your changes.

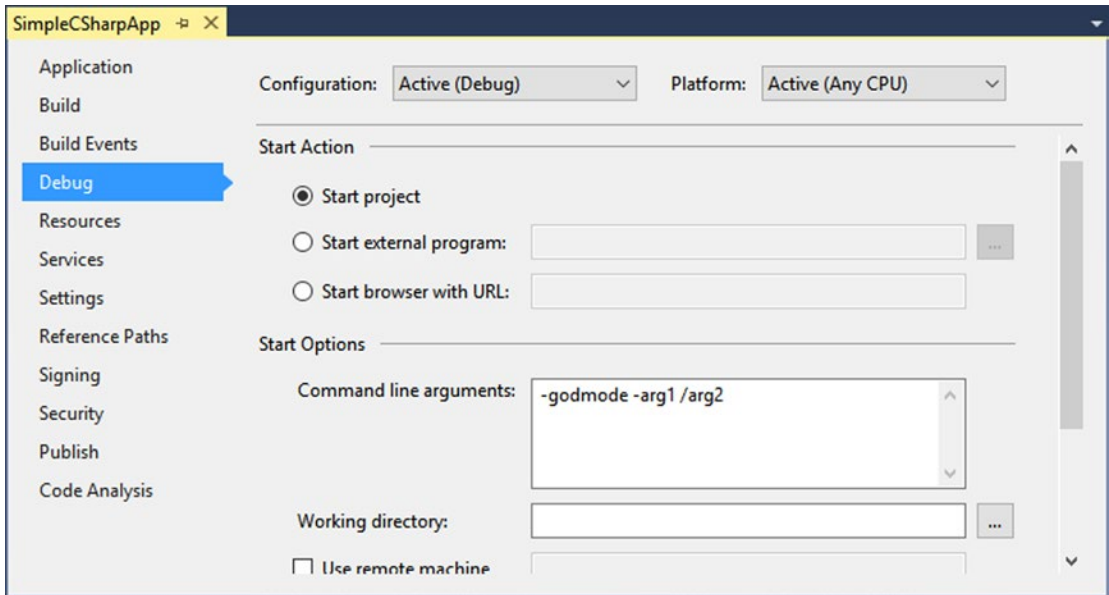

Figure 3-1. Setting command arguments via Visual Studio

After you have established such command-line arguments, they will automatically be passed to the `Main()` method when debugging or running your application within the Visual Studio IDE.

An Interesting Aside: Some Additional Members of the `System.Environment` Class

The `Environment` class exposes a number of extremely helpful methods beyond `GetCommandLineArgs()`. Specifically, this class allows you to obtain a number of details regarding the operating system currently hosting your .NET application using various static members. To illustrate the usefulness of `System.Environment`, update your `Main()` method to call a helper method named `ShowEnvironmentDetails()`.

```
static int Main(string[] args)
{
    ...
    // Helper method within the Program class.
    ShowEnvironmentDetails();

    Console.ReadLine();
    return -1;
}
```

Implement this method within your Program class to call various members of the Environment type.

```
static void ShowEnvironmentDetails()
{
    // Print out the drives on this machine,
    // and other interesting details.
    foreach (string drive in Environment.GetLogicalDrives())
        Console.WriteLine("Drive: {0}", drive);

    Console.WriteLine("OS: {0}", Environment.OSVersion);
    Console.WriteLine("Number of processors: {0}",
        Environment.ProcessorCount);
    Console.WriteLine(".NET Version: {0}",
        Environment.Version);
}
```

The following output shows a possible test run of invoking this method. Of course, if you did not specify command-line arguments via the Visual Studio Debug tab, you will not find them printed to the console.

```
***** My First C# App *****
```

```
Hello World!
```

```
Arg: -godmode
```

```
Arg: -arg1
```

```
Arg: /arg2
```

```
Drive: C:\
```

```
Drive: D:\
```

```
OS: Microsoft Windows NT 6.2.9200.0
```

```
Number of processors: 8
```

```
.NET Version: 4.0.30319.42000
```

The Environment type defines members other than those shown in the previous example. Table 3-1 documents some additional properties of interest; however, be sure to check out the .NET Framework 4.6 SDK documentation for full details.

Table 3-1. Select Properties of System.Environment

| Property | Meaning in Life |
|------------------------|---|
| ExitCode | Gets or sets the exit code for the application |
| Is64BitOperatingSystem | Returns a bool to represent whether the host machine is running a 64-bit OS |
| MachineName | Gets the name of the current machine |
| NewLine | Gets the newline symbol for the current environment |
| SystemDirectory | Returns the full path to the system directory |
| UserName | Returns the name of the user that started this application |
| Version | Returns a Version object that represents the version of the .NET platform |

■ **Source Code** The SimpleCSharpApp project is located in the Chapter 3 subdirectory.

The System.Console Class

Almost all the example applications created over the course of the initial chapters of this book make extensive use of the `System.Console` class. While it is true that a console user interface (CUI) may not be as enticing as a graphical user interface (GUI) or web application, restricting the early examples to console programs will allow you to keep focused on the syntax of C# and the core aspects of the .NET platform, rather than dealing with the complexities of building desktop GUIs or web sites.

As its name implies, the `Console` class encapsulates input, output, and error-stream manipulations for console-based applications. Table 3-2 lists some (but definitely not all) members of interest. As you can see, the `Console` class does provide some members that can spice up a simple command-line application, such as the ability to change background and foreground colors and issue beep noises (in a variety of frequencies!).

Table 3-2. *Select Members of System.Console*

| Member | Meaning in Life |
|------------------------------|---|
| <code>Beep()</code> | This method forces the console to emit a beep of a specified frequency and duration. |
| <code>BackgroundColor</code> | These properties set the background/foreground colors for the current output. |
| <code>ForegroundColor</code> | They may be assigned any member of the <code>ConsoleColor</code> enumeration. |
| <code>BufferHeight</code> | These properties control the height/width of the console's buffer area. |
| <code>BufferWidth</code> | |
| <code>Title</code> | This property gets or sets the title of the current console. |
| <code>WindowHeight</code> | These properties control the dimensions of the console in relation to the established buffer. |
| <code>WindowWidth</code> | |
| <code>WindowTop</code> | |
| <code>WindowLeft</code> | |
| <code>Clear()</code> | This method clears the established buffer and console display area. |

Basic Input and Output with the Console Class

In addition to the members in Table 3-2, the `Console` type defines a set of methods to capture input and output, all of which are static and are, therefore, called by prefixing the name of the class (`Console`) to the method name. As you have seen, `WriteLine()` pumps a text string (including a carriage return) to the output stream. The `Write()` method pumps text to the output stream without a carriage return. `ReadLine()` allows you to receive information from the input stream up until the Enter key is pressed, while `Read()` is used to capture a single character from the input stream.

To illustrate basic I/O using the `Console` class, create a new Console Application project named `BasicConsoleIO` and update your `Main()` method to call a helper method named `GetUserData()`.

```
class Program
{
    static void Main(string[] args)
    {
        Console.WriteLine("***** Basic Console I/O *****");
        GetUserData();
        Console.ReadLine();
    }

    private static void GetUserData()
    {
    }
}
```

■ **Note** Visual Studio supports a number of “code snippets” that will insert code once activated. The `cw` code snippet is quite useful during the early chapters of this text, in that it will automatically expand to `Console.WriteLine()`! To test this for yourself, type in `cw` somewhere within your `Main()` method and hit the `Tab` key twice (sadly, there is no code snippet for `Console.ReadLine()`). To see all code snippets, right-click in a C# code file and choose the `Insert Snippet` menu option.

Implement this method within the `Program` class with logic that prompts the user for some bits of information and echoes each item to the standard output stream. For example, you could ask the user for a name and age (which will be treated as a text value for simplicity, rather than the expected numerical value), as follows:

```
static void GetUserData()
{
    // Get name and age.
    Console.Write("Please enter your name: ");
    string userName = Console.ReadLine();
    Console.Write("Please enter your age: ");
    string userAge = Console.ReadLine();

    // Change echo color, just for fun.
    ConsoleColor prevColor = Console.ForegroundColor;
    Console.ForegroundColor = ConsoleColor.Yellow;

    // Echo to the console.
    Console.WriteLine("Hello {0}! You are {1} years old.",
        userName, userAge);

    // Restore previous color.
    Console.ForegroundColor = prevColor;
}
```

Not surprisingly, when you run this application, the input data is printed to the console (using a custom color to boot!).

Formatting Console Output

During these first few chapters, you might have noticed numerous occurrences of tokens such as `{0}` and `{1}` embedded within various string literals. The .NET platform supports a style of string formatting slightly akin to the `printf()` statement of C. Simply put, when you are defining a string literal that contains segments of data whose value is not known until runtime, you are able to specify a placeholder within the literal using this curly-bracket syntax. At runtime, the values passed into `Console.WriteLine()` are substituted for each placeholder.

The first parameter to `WriteLine()` represents a string literal that contains optional placeholders designated by `{0}`, `{1}`, `{2}`, and so forth. Be aware that the first ordinal number of a curly-bracket placeholder always begins with 0. The remaining parameters to `WriteLine()` are simply the values to be inserted into the respective placeholders.

■ **Note** If you have more uniquely numbered curly-bracket placeholders than fill arguments, you will receive a format exception at runtime. However, if you have more fill arguments than placeholders, the unused fill arguments are ignored.

It is permissible for a given placeholder to repeat within a given string. For example, if you are a Beatles fan and want to build the string "9, Number 9, Number 9", you would write this:

```
// John says...
Console.WriteLine("{0}, Number {0}, Number {0}", 9);
```

Also, know that it is possible to position each placeholder in any location within a string literal, and it need not follow an increasing sequence. For example, consider the following code snippet:

```
// Prints: 20, 10, 30
Console.WriteLine("{1}, {0}, {2}", 10, 20, 30);
```

Formatting Numerical Data

If you require more elaborate formatting for numerical data, each placeholder can optionally contain various format characters. Table 3-3 shows the most common formatting options.

Table 3-3. .NET Numerical Format Characters

| String Format Character | Meaning in Life |
|-------------------------|--|
| C or c | Used to format currency. By default, the flag will prefix the local cultural symbol (a dollar sign [\$] for U.S. English). |
| D or d | Used to format decimal numbers. This flag may also specify the minimum number of digits used to pad the value. |
| E or e | Used for exponential notation. Casing controls whether the exponential constant is uppercase (E) or lowercase (e). |
| F or f | Used for fixed-point formatting. This flag may also specify the minimum number of digits used to pad the value. |
| G or g | Stands for <i>general</i> . This character can be used to format a number to fixed or exponential format. |
| N or n | Used for basic numerical formatting (with commas). |
| X or x | Used for hexadecimal formatting. If you use an uppercase X, your hex format will also contain uppercase characters. |

These format characters are suffixed to a given placeholder value using the colon token (e.g., {0:C}, {1:d}, {2:X}). To illustrate, update the `Main()` method to call a new helper function named `FormatNumericalData()`. Implement this method in your `Program` class to format a fixed numerical value in a variety of ways.

```
// Now make use of some format tags.
static void FormatNumericalData()
{
    Console.WriteLine("The value 99999 in various formats:");
    Console.WriteLine("c format: {0:c}", 99999);
    Console.WriteLine("d9 format: {0:d9}", 99999);
    Console.WriteLine("f3 format: {0:f3}", 99999);
    Console.WriteLine("n format: {0:n}", 99999);

    // Notice that upper- or lowercasing for hex
    // determines if letters are upper- or lowercase.
    Console.WriteLine("E format: {0:E}", 99999);
    Console.WriteLine("e format: {0:e}", 99999);
    Console.WriteLine("X format: {0:X}", 99999);
    Console.WriteLine("x format: {0:x}", 99999);
}
```

The following output shows the result of calling the `FormatNumericalData()` method:

The value 99999 in various formats:

```
c format: $99,999.00
d9 format: 000099999
f3 format: 99999.000
n format: 99,999.00
E format: 9.999900E+004
e format: 9.999900e+004
X format: 1869F
x format: 1869f
```

You'll see additional formatting examples where required throughout this text; however, if you are interested in digging into .NET string formatting further, look up the topic "Formatting Types" within the .NET Framework 4.6 SDK documentation.

■ **Source Code** The `BasicConsoleIO` project is located in the [Chapter 3](#) subdirectory.

Formatting Numerical Data Beyond Console Applications

On a final note, be aware that the use of the .NET string formatting characters is not limited to console programs. This same formatting syntax can be used when calling the static `string.Format()` method. This can be helpful when you need to compose textual data at runtime for use in any application type (e.g., desktop GUI app, ASP.NET web app, and so forth).

The `string.Format()` method returns a new `string` object, which is formatted according to the provided flags. After this point, you are free to use the textual data as you see fit. For example, assume you are building a graphical WPF desktop application and need to format a string for display in a message box. The following code illustrates how to do so, but be aware that this code will not compile until you reference the `PresentationFramework.dll` assembly for use by your project (see [Chapter 2](#) for information on referencing libraries using Visual Studio).

```
static void DisplayMessage()
{
    // Using string.Format() to format a string literal.
    string userMessage = string.Format("100000 in hex is {0:x}", 100000);

    // You need to reference PresentationFramework.dll
    // in order to compile this line of code!
    System.Windows.MessageBox.Show(userMessage);
}
```

■ **Note** .NET 4.6 has introduced an alternative syntax to the curly-bracket placeholders termed *string interpolation syntax*. You will examine this approach later in the chapter.

System Data Types and Corresponding C# Keywords

Like any programming language, C# defines keywords for fundamental data types, which are used to represent local variables, class data member variables, method return values, and parameters. Unlike other programming languages, however, these keywords are much more than simple compiler-recognized tokens. Rather, the C# data type keywords are actually shorthand notations for full-blown types in the `System` namespace. Table 3-4 lists each system data type, its range, the corresponding C# keyword, and the type's compliance with the common language specification (CLS).

Table 3-4. *The Intrinsic Data Types of C#*

| C# Shorthand | CLS Compliant? | System Type | Range | Meaning in Life |
|----------------------|----------------|-----------------------------|---|--|
| <code>bool</code> | Yes | <code>System.Boolean</code> | true or false | Represents truth or falsity |
| <code>sbyte</code> | No | <code>System.SByte</code> | -128 to 127 | Signed 8-bit number |
| <code>byte</code> | Yes | <code>System.Byte</code> | 0 to 255 | Unsigned 8-bit number |
| <code>short</code> | Yes | <code>System.Int16</code> | -32,768 to 32,767 | Signed 16-bit number |
| <code>ushort</code> | No | <code>System.UInt16</code> | 0 to 65,535 | Unsigned 16-bit number |
| <code>int</code> | Yes | <code>System.Int32</code> | -2,147,483,648 to 2,147,483,647 | Signed 32-bit number |
| <code>uint</code> | No | <code>System.UInt32</code> | 0 to 4,294,967,295 | Unsigned 32-bit number |
| <code>long</code> | Yes | <code>System.Int64</code> | -9,223,372,036,854,775,808 to 9,223,372,036,854,775,807 | Signed 64-bit number |
| <code>ulong</code> | No | <code>System.UInt64</code> | 0 to 18,446,744,073,709,551,615 | Unsigned 64-bit number |
| <code>char</code> | Yes | <code>System.Char</code> | U+0000 to U+ffff | Single 16-bit Unicode character |
| <code>float</code> | Yes | <code>System.Single</code> | -3.4×10^{38} to $+3.4 \times 10^{38}$ | 32-bit floating-point number |
| <code>double</code> | Yes | <code>System.Double</code> | $\pm 5.0 \times 10^{-324}$ to $\pm 1.7 \times 10^{308}$ | 64-bit floating-point number |
| <code>decimal</code> | Yes | <code>System.Decimal</code> | $(-7.9 \times 10^{28}$ to $7.9 \times 10^{28}) / (10^{0 \text{ to } 28})$ | 128-bit signed number |
| <code>string</code> | Yes | <code>System.String</code> | Limited by system memory | Represents a set of Unicode characters |
| <code>Object</code> | Yes | <code>System.Object</code> | Can store any data type in an object variable | The base class of all types in the .NET universe |

■ **Note** Recall from Chapter 1 that CLS-compliant .NET code can be used by any managed programming language. If you expose non-CLS-compliant data from your programs, other .NET languages might not be able to make use of it.

By default, a floating-point number is treated as a `double`. To declare a `float` variable, use the suffix `f` or `F` to the raw numerical value (`5.3F`), and use the suffix `m` or `M` to a floating-point number to declare a decimal (`300.5M`). Finally, raw whole numbers default to an `int` data type. To set the underlying data type to a `long`, suffix `l` or `L` (`4L`).

Variable Declaration and Initialization

When you are declaring a local variable (e.g., a variable within a member scope), you do so by specifying the data type followed by the variable's name. To begin, create a new Console Application project named `BasicDataTypes`. Update the `Program` class with the following helper method that is called from within `Main()`:

```
static void LocalVarDeclarations()
{
    Console.WriteLine("=> Data Declarations:");
    // Local variables are declared as so:
    // dataType varName;
    int myInt;
    string myString;
    Console.WriteLine();
}
```

Be aware that it is a *compiler error* to make use of a local variable before assigning an initial value. Given this, it is good practice to assign an initial value to your local data points at the time of declaration. You may do so on a single line or by separating the declaration and assignment into two code statements.

```
static void LocalVarDeclarations()
{
    Console.WriteLine("=> Data Declarations:");
    // Local variables are declared and initialized as follows:
    // dataType varName = initialValue;
    int myInt = 0;

    // You can also declare and assign on two lines.
    string myString;
    myString = "This is my character data";

    Console.WriteLine();
}
```

It is also permissible to declare multiple variables of the same underlying type on a single line of code, as in the following three `bool` variables:

```
static void LocalVarDeclarations()
{
    Console.WriteLine("=> Data Declarations:");
    int myInt = 0;
    string myString;
    myString = "This is my character data";

    // Declare 3 bools on a single line.
    bool b1 = true, b2 = false, b3 = b1;
    Console.WriteLine();
}
```

Since the C# `bool` keyword is simply a shorthand notation for the `System.Boolean` structure, it is also possible to allocate any data type using its full name (of course, the same point holds true for any C# data type keyword). Here is the final implementation of `LocalVarDeclarations()`, which illustrates various ways to declare a local variable:

```
static void LocalVarDeclarations()
{
    Console.WriteLine("=> Data Declarations:");
    // Local variables are declared and initialized as follows:
    // dataType varName = initialValue;
    int myInt = 0;

    string myString;
    myString = "This is my character data";

    // Declare 3 bools on a single line.
    bool b1 = true, b2 = false, b3 = b1;

    // Use System.Boolean data type to declare a bool.
    System.Boolean b4 = false;

    Console.WriteLine("Your data: {0}, {1}, {2}, {3}, {4}, {5}",
        myInt, myString, b1, b2, b3, b4);

    Console.WriteLine();
}
```

Intrinsic Data Types and the new Operator

All intrinsic data types support what is known as a *default constructor* (see Chapter 5). This feature allows you to create a variable using the `new` keyword, which automatically sets the variable to its default value.

- `bool` variables are set to `false`.
- Numeric data is set to 0 (or 0.0 in the case of floating-point data types).
- `char` variables are set to a single empty character.
- `BigInteger` variables are set to 0.
- `DateTime` variables are set to 1/1/0001 12:00:00 AM.
- Object references (including strings) are set to `null`.

■ **Note** The `BigInteger` data type mentioned in the previous list will be explained in just a bit.

Although it is more cumbersome to use the `new` keyword when creating a basic data type variable, the following is syntactically well-formed C# code:

```
static void NewingDataTypes()
{
    Console.WriteLine("=> Using new to create variables:");
    bool b = new bool();           // Set to false.
    int i = new int();            // Set to 0.
    double d = new double();      // Set to 0.
    DateTime dt = new DateTime(); // Set to 1/1/0001 12:00:00 AM
    Console.WriteLine("{0}, {1}, {2}, {3}", b, i, d, dt);
    Console.WriteLine();
}
```

The Data Type Class Hierarchy

It is interesting to note that even the primitive .NET data types are arranged in a *class hierarchy*. If you are new to the world of inheritance, you will discover the full details in Chapter 6. Until then, just understand that types at the top of a class hierarchy provide some default behaviors that are granted to the derived types. The relationship between these core system types can be understood as shown in Figure 3-2.

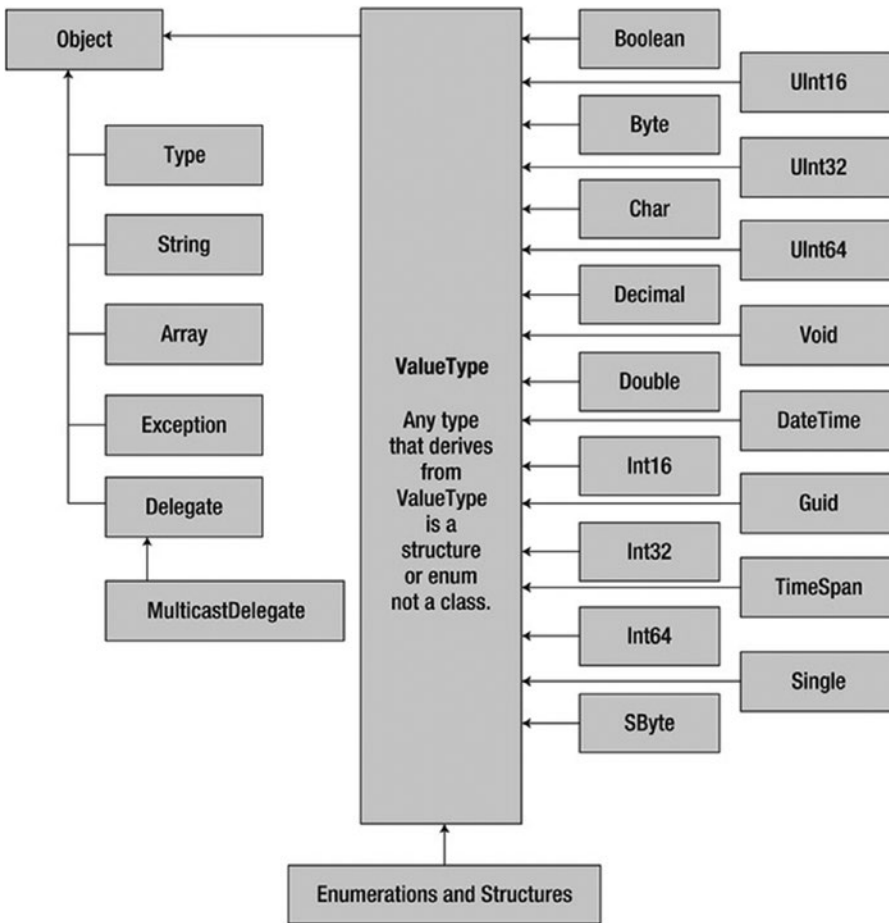

Figure 3-2. The class hierarchy of system types

Notice that each type ultimately derives from `System.Object`, which defines a set of methods (e.g., `ToString()`, `Equals()`, `GetHashCode()`) common to all types in the .NET base class libraries (these methods are fully detailed in Chapter 6).

Also note that many numerical data types derive from a class named `System.ValueType`. Descendants of `ValueType` are automatically allocated on the stack and, therefore, have a predictable lifetime and are quite efficient. On the other hand, types that do not have `System.ValueType` in their inheritance chain (such as `System.Type`, `System.String`, `System.Array`, `System.Exception`, and `System.Delegate`) are not allocated on the stack but on the garbage-collected heap. (You can find more information on this distinction in Chapter 4.)

Without getting too hung up on the details of `System.Object` and `System.ValueType`, just understand that because a C# keyword (such as `int`) is simply shorthand notation for the corresponding system type (in this case, `System.Int32`), the following is perfectly legal syntax, given that `System.Int32` (the C# `int`) eventually derives from `System.Object` and, therefore, can invoke any of its public members, as illustrated by this additional helper function:

```
static void ObjectFunctionality()
{
    Console.WriteLine("=> System.Object Functionality:");

    // A C# int is really a shorthand for System.Int32,
    // which inherits the following members from System.Object.
    Console.WriteLine("12.GetHashCode() = {0}", 12.GetHashCode());
    Console.WriteLine("12.Equals(23) = {0}", 12.Equals(23));
    Console.WriteLine("12.ToString() = {0}", 12.ToString());
    Console.WriteLine("12.GetType() = {0}", 12.GetType());
    Console.WriteLine();
}
```

If you were to call this method from within `Main()`, you would find the output shown here:

```
=> System.Object Functionality:

12.GetHashCode() = 12
12.Equals(23) = False
12.ToString() = 12
12.GetType() = System.Int32
```

Members of Numerical Data Types

To continue experimenting with the intrinsic C# data types, understand that the numerical types of .NET support `MaxValue` and `MinValue` properties that provide information regarding the range a given type can store. In addition to the `MinValue/MaxValue` properties, a given numerical system type may define further useful members. For example, the `System.Double` type allows you to obtain the values for `epsilon` and `infinity` (which might be of interest to those of you with a mathematical flare). To illustrate, consider the following helper function:

```
static void DataTypeFunctionality()
{
    Console.WriteLine("=> Data type Functionality:");

    Console.WriteLine("Max of int: {0}", int.MaxValue);
    Console.WriteLine("Min of int: {0}", int.MinValue);
    Console.WriteLine("Max of double: {0}", double.MaxValue);
}
```

```

Console.WriteLine("Min of double: {0}", double.MinValue);
Console.WriteLine("double.Epsilon: {0}", double.Epsilon);
Console.WriteLine("double.PositiveInfinity: {0}",
    double.PositiveInfinity);
Console.WriteLine("double.NegativeInfinity: {0}",
    double.NegativeInfinity);
Console.WriteLine();
}

```

Members of System.Boolean

Next, consider the `System.Boolean` data type. The only valid assignment a C# `bool` can take is from the set `{true | false}`. Given this point, it should be clear that `System.Boolean` does not support a `MinValue/MaxValue` property set but rather `TrueString/FalseString` (which yields the string "True" or "False", respectively). Here's an example:

```

Console.WriteLine("bool.FalseString: {0}", bool.FalseString);
Console.WriteLine("bool.TrueString: {0}", bool.TrueString);

```

Members of System.Char

C# textual data is represented by the `string` and `char` keywords, which are simple shorthand notations for `System.String` and `System.Char`, both of which are Unicode under the hood. As you might already know, a `string` represents a contiguous set of characters (e.g., "Hello"), while the `char` can represent a single slot in a `string` (e.g., 'H').

The `System.Char` type provides you with a great deal of functionality beyond the ability to hold a single point of character data. Using the static methods of `System.Char`, you are able to determine whether a given character is numerical, alphabetical, a point of punctuation, or whatnot. Consider the following method:

```

static void CharFunctionality()
{
    Console.WriteLine("=> char type Functionality:");
    char myChar = 'a';
    Console.WriteLine("char.IsDigit('a'): {0}", char.IsDigit(myChar));
    Console.WriteLine("char.IsLetter('a'): {0}", char.IsLetter(myChar));
    Console.WriteLine("char.IsWhiteSpace('Hello There', 5): {0}",
        char.IsWhiteSpace("Hello There", 5));
    Console.WriteLine("char.IsWhiteSpace('Hello There', 6): {0}",
        char.IsWhiteSpace("Hello There", 6));
    Console.WriteLine("char.IsPunctuation('?'): {0}",
        char.IsPunctuation('?'));
    Console.WriteLine();
}

```

As illustrated in the previous method, many members of `System.Char` have two calling conventions: a single character or a string with a numerical index that specifies the position of the character to test.

Parsing Values from String Data

The .NET data types provide the ability to generate a variable of their underlying type given a textual equivalent (e.g., parsing). This technique can be extremely helpful when you want to convert some user input data (such as a selection from a GUI-based, drop-down list box) into a numerical value. Consider the following parsing logic within a method named `ParseFromStrings()`.

```
static void ParseFromStrings()
{
    Console.WriteLine("=> Data type parsing:");
    bool b = bool.Parse("True");
    Console.WriteLine("Value of b: {0}", b);
    double d = double.Parse("99.884");
    Console.WriteLine("Value of d: {0}", d);
    int i = int.Parse("8");
    Console.WriteLine("Value of i: {0}", i);
    char c = Char.Parse("w");
    Console.WriteLine("Value of c: {0}", c);
    Console.WriteLine();
}
```

System.DateTime and System.TimeSpan

The `System` namespace defines a few useful data types for which there are no C# keywords, such as the `DateTime` and `TimeSpan` structures. (I'll leave the investigation of `System.Guid` and `System.Void`, as shown in Figure 3-2, to interested readers, but do be aware that these two data types in the `System` namespace are seldom useful in most applications.)

The `DateTime` type contains data that represents a specific date (month, day, year) and time value, both of which may be formatted in a variety of ways using the supplied members. The `TimeSpan` structure allows you to easily define and transform units of time using various members.

```
static void UseDatesAndTimes()
{
    Console.WriteLine("=> Dates and Times:");

    // This constructor takes (year, month, day).
    DateTime dt = new DateTime(2015, 10, 17);

    // What day of the month is this?
    Console.WriteLine("The day of {0} is {1}", dt.Date, dt.DayOfWeek);

    // Month is now December.
    dt = dt.AddMonths(2);
    Console.WriteLine("Daylight savings: {0}", dt.IsDaylightSavingTime());
}
```

```

// This constructor takes (hours, minutes, seconds).
TimeSpan ts = new TimeSpan(4, 30, 0);
Console.WriteLine(ts);

// Subtract 15 minutes from the current TimeSpan and
// print the result.
Console.WriteLine(ts.Subtract(new TimeSpan(0, 15, 0)));
}

```

The System.Numerics.dll Assembly

The `System.Numerics` namespace defines a structure named `BigInteger`. As its name implies, the `BigInteger` data type can be used when you need to represent *humongous* numerical values, which are not constrained by a fixed upper or lower limit.

■ **Note** The `System.Numerics` namespace defines a second structure named `Complex`, which allows you to model mathematically complex numerical data (e.g., imaginary units, real data, hyperbolic tangents). Consult the .NET Framework 4.6 SDK documentation if you are interested.

While many of your .NET applications might never need to make use of the `BigInteger` structure, if you do find the need to define a massive numerical value, your first step is to reference the `System.Numerics.dll` assembly into your project. If you want to follow along with the current example, perform the following tasks:

1. Select the Project ► Add Reference menu option of Visual Studio.
2. Locate and select the `System.Numerics.dll` assembly within the list of presented libraries found in the Framework tab on the left side.
3. Click the OK button.

After you have done so, add the following `using` directive to the file, which will be using the `BigInteger` data type:

```

// BigInteger lives here!
using System.Numerics;

```

At this point, you can create a `BigInteger` variable using the `new` operator. Within the constructor, you can specify a numerical value, including floating-point data. However, recall that when you define a literal whole number (such as 500), the runtime will default the data type to an `int`. Likewise, literal floating-point data (such as 55.333) will default to a `double`. How, then, can you set `BigInteger` to a massive value while not overflowing the default data types used for raw numerical values?

The simplest approach is to establish the massive numerical value as a text literal, which can be converted into a `BigInteger` variable via the static `Parse()` method. If required, you can also pass in a byte array directly to the constructor of the `BigInteger` class.

Table 3-5. *Select Members of System.String*

| String Member | Meaning in Life |
|---------------|--|
| Length | This property returns the length of the current string. |
| Compare() | This static method compares two strings. |
| Contains() | This method determines whether a string contains a specific substring. |
| Equals() | This method tests whether two string objects contain identical character data. |
| Format() | This static method formats a string using other primitives (e.g., numerical data, other strings) and the {0} notation examined earlier in this chapter. |
| Insert() | This method inserts a string within a given string. |
| PadLeft() | These methods are used to pad a string with some characters. |
| PadRight() | |
| Remove() | These methods are used to receive a copy of a string with modifications (characters removed or replaced). |
| Replace() | |
| Split() | This method returns a <code>String</code> array containing the substrings in this instance that are delimited by elements of a specified <code>char</code> array or <code>string</code> array. |
| Trim() | This method removes all occurrences of a set of specified characters from the beginning and end of the current string. |
| ToUpper() | These methods create a copy of the current string in uppercase or lowercase format, respectively. |
| ToLower() | |

Basic String Manipulation

Working with the members of `System.String` is as you would expect. Simply declare a `string` variable and make use of the provided functionality via the dot operator. Be aware that a few of the members of `System.String` are static members and are, therefore, called at the class (rather than the object) level. Assume you have created a new Console Application project named `FunWithStrings`. Author the following method, which should be called from within `Main()`:

```
static void BasicStringFunctionality()
{
    Console.WriteLine("=> Basic String functionality:");
    string firstName = "Freddy";
    Console.WriteLine("Value of firstName: {0}", firstName);
    Console.WriteLine("firstName has {0} characters.", firstName.Length);
    Console.WriteLine("firstName in uppercase: {0}", firstName.ToUpper());
    Console.WriteLine("firstName in lowercase: {0}", firstName.ToLower());
    Console.WriteLine("firstName contains the letter y?: {0}",
        firstName.Contains("y"));
    Console.WriteLine("firstName after replace: {0}", firstName.Replace("dy", ""));
    Console.WriteLine();
}
```

There's not too much to say here, as this method simply invokes various members, such as `ToUpper()` and `Contains()`, on a local `string` variable to yield various formats and transformations. Here is the initial output:

```
***** Fun with Strings *****

=> Basic String functionality:
Value of firstName: Freddy
firstName has 6 characters.
firstName in uppercase: FREDDY
firstName in lowercase: freddy
firstName contains the letter y?: True
firstName after replace: Fred
```

While this output might not seem too surprising, the output seen via calling the `Replace()` method is a bit misleading. In reality, the `firstName` variable has not changed at all; rather, you receive a new `string` in a modified format. You will revisit the immutable nature of strings in just a few moments.

String Concatenation

`string` variables can be connected together to build larger strings via the `C# +` (as well as `+=`) operator. As you might know, this technique is formally termed *string concatenation*. Consider the following new helper function:

```
static void StringConcatenation()
{
    Console.WriteLine("=> String concatenation:");
    string s1 = "Programming the ";
    string s2 = "PsychoDrill (PTP)";
    string s3 = s1 + s2;
    Console.WriteLine(s3);
    Console.WriteLine();
}
```

You might be interested to know that the `C# +` symbol is processed by the compiler to emit a call to the static `String.Concat()` method. Given this, it is possible to perform string concatenation by calling `String.Concat()` directly (although you really have not gained anything by doing so—in fact, you have incurred additional keystrokes!).

```
static void StringConcatenation()
{
    Console.WriteLine("=> String concatenation:");
    string s1 = "Programming the ";
    string s2 = "PsychoDrill (PTP)";
    string s3 = String.Concat(s1, s2);
    Console.WriteLine(s3);
    Console.WriteLine();
}
```

Escape Characters

As in other C-based languages, C# string literals may contain various *escape characters*, which qualify how the character data should be printed to the output stream. Each escape character begins with a backslash, followed by a specific token. In case you are a bit rusty on the meanings behind these escape characters, Table 3-6 lists the more common options.

Table 3-6. *String Literal Escape Characters*

| Character | Meaning in Life |
|-----------|---|
| \' | Inserts a single quote into a string literal. |
| \" | Inserts a double quote into a string literal. |
| \\ | Inserts a backslash into a string literal. This can be quite helpful when defining file or network paths. |
| \a | Triggers a system alert (beep). For console programs, this can be an audio clue to the user. |
| \n | Inserts a new line (on Windows platforms). |
| \r | Inserts a carriage return. |
| \t | Inserts a horizontal tab into the string literal. |

For example, to print a string that contains a tab between each word, you can make use of the `\t` escape character. Or assume you want to create a string literal that contains quotation marks, another that defines a directory path, and a final string literal that inserts three blank lines after printing the character data. To do so without compiler errors, you would need to make use of the `\'`, `\\`, and `\n` escape characters. Also, to annoy any person within a 10-foot radius from you, notice that I have embedded an alarm within each string literal (to trigger a beep). Consider the following:

```
static void EscapeChars()
{
    Console.WriteLine("=> Escape characters:\a");
    string strWithTabs = "Model\tColor\tSpeed\tPet Name\a ";
    Console.WriteLine(strWithTabs);

    Console.WriteLine("Everyone loves \"Hello World\"\a ");
    Console.WriteLine("C:\\MyApp\\bin\\Debug\a ");

    // Adds a total of 4 blank lines (then beep again!).
    Console.WriteLine("All finished.\n\n\n\a ");
    Console.WriteLine();
}
```

Defining Verbatim Strings

When you prefix a string literal with the @ symbol, you have created what is termed a *verbatim string*. Using verbatim strings, you disable the processing of a literal's escape characters and print out a string as is. This can be most useful when working with strings representing directory and network paths. Therefore, rather than making use of \\ escape characters, you can simply write the following:

```
// The following string is printed verbatim,
// thus all escape characters are displayed.
Console.WriteLine(@"C:\MyApp\bin\Debug");
```

Also note that verbatim strings can be used to preserve white space for strings that flow over multiple lines.

```
// White space is preserved with verbatim strings.
string myLongString = @"This is a very
    very
        long string";
Console.WriteLine(myLongString);
```

Using verbatim strings, you can also directly insert a double quote into a literal string by doubling the " token.

```
Console.WriteLine(@"Cerebus said ""Darr! Pret-ty sun-sets""");
```

Strings and Equality

As fully explained in Chapter 4, a *reference type* is an object allocated on the garbage-collected managed heap. By default, when you perform a test for equality on reference types (via the C# == and != operators), you will be returned true if the references are pointing to the same object in memory. However, even though the string data type is indeed a reference type, the equality operators have been redefined to compare the *values* of string objects, not the object in memory to which they refer.

```
static void StringEquality()
{
    Console.WriteLine("=> String equality:");
    string s1 = "Hello!";
    string s2 = "Yo!";
    Console.WriteLine("s1 = {0}", s1);
    Console.WriteLine("s2 = {0}", s2);
    Console.WriteLine();

    // Test these strings for equality.
    Console.WriteLine("s1 == s2: {0}", s1 == s2);
    Console.WriteLine("s1 == Hello!: {0}", s1 == "Hello!");
    Console.WriteLine("s1 == HELLO!: {0}", s1 == "HELLO!");
    Console.WriteLine("s1 == hello!: {0}", s1 == "hello!");
    Console.WriteLine("s1.Equals(s2): {0}", s1.Equals(s2));
    Console.WriteLine("Yo.Equals(s2): {0}", "Yo!".Equals(s2));
    Console.WriteLine();
}
```

The C# equality operators perform a case-sensitive, character-by-character equality test on string objects. Therefore, "Hello!" is not equal to "HELLO!", which is also different from "hello!". Also, keeping the connection between `string` and `System.String` in mind, notice that you are able to test for equality using the `Equals()` method of `String` as well as the baked-in equality operators. Finally, given that every string literal (such as "Yo") is a valid `System.String` instance, you are able to access string-centric functionality from a fixed sequence of characters.

Strings Are Immutable

One of the interesting aspects of `System.String` is that after you assign a string object with its initial value, the character data *cannot be changed*. At first glance, this might seem like a flat-out lie, given that you are always reassigning strings to new values and because the `System.String` type defines a number of methods that appear to modify the character data in one way or another (such as uppercasing and lowercasing). However, if you look more closely at what is happening behind the scenes, you will notice the methods of the string type are, in fact, returning you a new string object in a modified format.

```
static void StringsAreImmutable()
{
    // Set initial string value.
    string s1 = "This is my string.";
    Console.WriteLine("s1 = {0}", s1);

    // Uppercase s1?
    string upperString = s1.ToUpper();
    Console.WriteLine("upperString = {0}", upperString);

    // Nope! s1 is in the same format!
    Console.WriteLine("s1 = {0}", s1);
}
```

If you examine the relevant output that follows, you can verify that the original string object (`s1`) is not uppercased when calling `ToUpper()`. Rather, you are returned a *copy* of the string in a modified format.

```
s1 = This is my string.
upperString = THIS IS MY STRING.
s1 = This is my string.
```

The same law of immutability holds true when you use the C# assignment operator. To illustrate, implement the following `StringsAreImmutable2()` method:

```
static void StringsAreImmutable2()
{
    string s2 = "My other string";
    s2 = "New string value";
}
```

Now, compile your application and load the assembly into `ildasm.exe` (see Chapter 1). The following output shows what you would find if you were to generate CIL code for the `StringsAreImmutable2()` method:

```
.method private hidebysig static void StringsAreImmutable2() cil managed
{
    // Code size 14 (0xe)
    .maxstack 1
    .locals init ([0] string s2)
    IL_0000: nop
    IL_0001: ldstr      "My other string"
    IL_0006: stloc.0
    IL_0007: ldstr      "New string value"
    IL_000c: stloc.0
    IL_000d: ret
} // end of method Program::StringAreImmutable2
```

Although you have yet to examine the low-level details of the CIL, note the numerous calls to the `ldstr` (load string) opcode. Simply put, the `ldstr` opcode of the CIL loads a new `string` object on the managed heap. The previous `string` object that contained the value "My other string" will eventually be garbage collected.

So, what exactly are you to gather from this insight? In a nutshell, the `string` class can be inefficient and result in bloated code if misused, especially when performing string concatenation or working with huge amounts of text data. If you need to represent basic character data such as a U.S. Social Security number, first or last names, or simple bits of text used within your application, the `string` class is the perfect choice.

However, if you are building an application that makes heavy use of frequently changing textual data (such as a word processing program), it would be a bad idea to represent the word processing data using `string` objects, as you will most certainly (and often indirectly) end up making unnecessary copies of string data. So, what is a programmer to do? Glad you asked.

The System.Text.StringBuilder Type

Given that the `string` type can be inefficient when used with reckless abandon, the .NET base class libraries provide the `System.Text` namespace. Within this (relatively small) namespace lives a class named `StringBuilder`. Like the `System.String` class, the `StringBuilder` defines methods that allow you to replace or format segments, for example. When you want to use this type in your C# code files, your first step is to make sure the following namespace is imported into your code file (this should already be the case for a new Visual Studio project):

```
// StringBuilder lives here!
using System.Text;
```

What is unique about the `StringBuilder` is that when you call members of this type, you are directly modifying the object's internal character data (making it more efficient), not obtaining a copy of the data in a modified format. When you create an instance of the `StringBuilder`, you can supply the object's initial startup values via one of many *constructors*. If you are new to the topic of constructors, simply understand

that constructors allow you to create an object with an initial state when you apply the `new` keyword. Consider the following usage of `StringBuilder`:

```
static void FunWithStringBuilder()
{
    Console.WriteLine("=> Using the StringBuilder:");
    StringBuilder sb = new StringBuilder("**** Fantastic Games ****");
    sb.Append("\n");
    sb.AppendLine("Half Life");
    sb.AppendLine("Morrowind");
    sb.AppendLine("Deus Ex" + "2");
    sb.AppendLine("System Shock");
    Console.WriteLine(sb.ToString());
    sb.Replace("2", " Invisible War");
    Console.WriteLine(sb.ToString());
    Console.WriteLine("sb has {0} chars.", sb.Length);
    Console.WriteLine();
}
```

Here, I have constructed a `StringBuilder` set to the initial value "**** Fantastic Games ****". As you can see, I am appending to the internal buffer and am able to replace or remove characters at will. By default, a `StringBuilder` is only able to initially hold a string of 16 characters or fewer (but will expand automatically if necessary); however, this default starting value can be changed via an additional constructor argument.

```
// Make a StringBuilder with an initial size of 256.
StringBuilder sb = new StringBuilder("**** Fantastic Games ****", 256);
```

If you append more characters than the specified limit, the `StringBuilder` object will copy its data into a new instance and grow the buffer by the specified limit.

String Interpolation

The curly bracket syntax illustrated within this chapter (`{0}`, `{1}`, and so on) has existed within the .NET platform since version 1.0. Starting with the current release, C# programmers can use an alternative syntax to build string literals that contain placeholders for variables. Formally, this is called *string interpolation*. While the output of the operation is identical to traditional string formatting syntax, this new approach allows you to directly embed the variables themselves, rather than tacking them on as a comma-delimited list.

Consider the following additional method of your `Program` class (`StringInterpolation()`), which builds a string variable using each approach:

```
static void StringInterpolation()
{
    // Some local variables we will plug into our larger string
    int age = 4;
    string name = "Soren";

    // Using curly bracket syntax.
    string greeting = string.Format("Hello {0} you are {1} years old.", name, age);

    // Using string interpolation
    string greeting2 = $"Hello {name} you are {age} years old.";
}
```

In the `greeting2` variable, notice how the string you are construction begins with a dollar sign prefix (`$`). Next, notice that the curly brackets still are used to mark a variable placeholder; however, rather than using a numerical tag, you are able to place the variable directly into the scope. The assumed advantage is that this new formatting syntax is a bit easier to read in a linear (left-to-right) fashion, given that you are not required to “jump to the end” to see the list of values to plug in at runtime.

There is another interesting aspect of this new syntax: the curly brackets used in string interpolation are a valid scope. Therefore, you can use the dot operation on the variables to change their state. Consider updates to each assembled string variable.

```
string greeting = string.Format("Hello {0} you are {1} years old.", name.ToUpper(), age);
string greeting2 = $"Hello {name.ToUpper()} you are {age} years old.";
```

Here, I have uppercased the name via a call to `ToUpper()`. Do note that in the string interpolation approach, you do *not* add a semicolon terminator when calling this method. Given this, you cannot use the curly-bracket scope as a fully blown method scope that contains numerous lines of executable code. Rather, you can invoke a single member on the object using the dot operator as well as define a simple general expression such as `{age += 1}`.

It is also worth noting that you can still use escape characters in the string literal within this new syntax. Thus, if you wanted to insert a tab, you can prefix a `\t` token as so:

```
string greeting = string.Format("\tHello {0} you are {1} years old.", name.ToUpper(), age);
string greeting2 = $" \tHello {name.ToUpper()} you are {age} years old.";
```

As you might expect, you are free to use either approach when building your string variables on the fly. Do keep in mind, however, that if you are using an earlier version of the .NET platform, string interpolation syntax will result in a compiler error. Thus, if you need to ensure your C# code will compile under multiple versions of the compiler, it is safer to stick to the traditional numerical placeholder approach.

■ **Source Code** The `FunWithStrings` project is located in the [Chapter 3](#) subdirectory.

Narrowing and Widening Data Type Conversions

Now that you understand how to work with intrinsic C# data types, let’s examine the related topic of *data type conversion*. Assume you have a new Console Application project named `TypeConversions` that defines the following class:

```
class Program
{
    static void Main(string[] args)
    {
        Console.WriteLine("***** Fun with type conversions *****");

        // Add two shorts and print the result.
        short numb1 = 9, numb2 = 10;
        Console.WriteLine("{0} + {1} = {2}",
            numb1, numb2, Add(numb1, numb2));
        Console.ReadLine();
    }
}
```

```

static int Add(int x, int y)
{
    return x + y;
}
}

```

Notice that the `Add()` method expects to be sent two `int` parameters. However, the `Main()` method is, in fact, sending in two `short` variables. While this might seem like a complete and total mismatch of data types, the program compiles and executes without error, returning the expected result of 19.

The reason the compiler treats this code as syntactically sound is because there is no possibility for loss of data. Given that the maximum value of a `short` (32,767) is well within the maximum range of an `int` (2,147,483,647), the compiler implicitly *widens* each `short` to an `int`. Formally speaking, *widening* is the term used to define an implicit *upward cast* that does not result in a loss of data.

■ **Note** Look up “Type Conversion Tables” in the .NET Framework 4.6 SDK documentation if you want to see permissible widening (and narrowing, discussed next) conversions for each C# data type.

Although this implicit widening worked in your favor for the previous example, other times this “feature” can be the source of compile-time errors. For example, assume that you have set values to `numb1` and `numb2` that (when added together) overflow the maximum value of a `short`. Also, assume you are storing the return value of the `Add()` method within a new local `short` variable, rather than directly printing the result to the console.

```

static void Main(string[] args)
{
    Console.WriteLine("***** Fun with type conversions *****");

    // Compiler error below!
    short numb1 = 30000, numb2 = 30000;
    short answer = Add(numb1, numb2);

    Console.WriteLine("{0} + {1} = {2}",
        numb1, numb2, answer);
    Console.ReadLine();
}

```

In this case, the compiler reports the following error:

```

Cannot implicitly convert type 'int' to 'short'. An explicit conversion exists (are you missing a cast?)

```

The problem is that although the `Add()` method is capable of returning an `int` with the value 60,000 (as this fits within the range of a `System.Int32`), the value cannot be stored in a `short`, as it overflows the bounds of this data type. Formally speaking, the CLR was unable to apply a *narrowing operation*. As you can guess, narrowing is the logical opposite of widening, in that a larger value is stored within a smaller data type variable.

It is important to point out that all narrowing conversions result in a compiler error, even when you can reason that the narrowing conversion should indeed succeed. For example, the following code also results in a compiler error:

```
// Another compiler error!
static void NarrowingAttempt()
{
    byte myByte = 0;
    int myInt = 200;
    myByte = myInt;

    Console.WriteLine("Value of myByte: {0}", myByte);
}
```

Here, the value contained within the `int` variable (`myInt`) is safely within the range of a `byte`; therefore, you would expect the narrowing operation to not result in a runtime error. However, given that C# is a language built with type safety in mind, you do indeed receive a compiler error.

When you want to inform the compiler that you are willing to deal with a possible loss of data because of a narrowing operation, you must apply an *explicit cast* using the C# casting operator, `()`. Consider the following update to the `Program` type:

```
class Program
{
    static void Main(string[] args)
    {
        Console.WriteLine("***** Fun with type conversions *****");
        short numb1 = 30000, numb2 = 30000;

        // Explicitly cast the int into a short (and allow loss of data).
        short answer = (short)Add(numb1, numb2);

        Console.WriteLine("{0} + {1} = {2}",
            numb1, numb2, answer);
        NarrowingAttempt();
        Console.ReadLine();
    }

    static int Add(int x, int y)
    {
        return x + y;
    }

    static void NarrowingAttempt()
    {
        byte myByte = 0;
        int myInt = 200;

        // Explicitly cast the int into a byte (no loss of data).
        myByte = (byte)myInt;
        Console.WriteLine("Value of myByte: {0}", myByte);
    }
}
```

At this point, the code compiles; however, the result of the addition is completely incorrect.

```
***** Fun with type conversions *****
30000 + 30000 = -5536
Value of myByte: 200
```

As you have just witnessed, an explicit cast allows you to force the compiler to apply a narrowing conversion, even when doing so may result in a loss of data. In the case of the `NarrowingAttempt()` method, this was not a problem because the value 200 can fit snugly within the range of a byte. However, in the case of adding the two `shorts` within `Main()`, the end result is completely unacceptable (30,000 + 30,000 = -5536?).

If you are building an application where loss of data is always unacceptable, C# provides the `checked` and `unchecked` keywords to ensure data loss does not escape undetected.

The checked Keyword

Let's begin by learning the role of the `checked` keyword. Assume you have a new method within `Program` that attempts to add two bytes, each of which has been assigned a value that is safely below the maximum (255). If you were to add the values of these types (casting the returned `int` to a byte), you would assume that the result would be the exact sum of each member.

```
static void ProcessBytes()
{
    byte b1 = 100;
    byte b2 = 250;
    byte sum = (byte)Add(b1, b2);

    // sum should hold the value 350. However, we find the value 94!
    Console.WriteLine("sum = {0}", sum);
}
```

If you were to view the output of this application, you might be surprised to find that `sum` contains the value 94 (rather than the expected 350). The reason is simple. Given that a `System.Byte` can hold a value only between 0 and 255 (inclusive, for a grand total of 256 slots), `sum` now contains the overflow value (350 - 256 = 94). By default, if you take no corrective course of action, overflow/underflow conditions occur without error.

To handle overflow or underflow conditions in your application, you have two options. Your first choice is to leverage your wits and programming skills to handle all overflow/underflow conditions manually. Of course, the problem with this technique is the simple fact that you are human, and even your best attempts might result in errors that have escaped your eyes.

Thankfully, C# provides the `checked` keyword. When you wrap a statement (or a block of statements) within the scope of the `checked` keyword, the C# compiler emits additional CIL instructions that test for overflow conditions that may result when adding, multiplying, subtracting, or dividing two numerical data types.

If an overflow has occurred, you will receive a runtime exception: `System.OverflowException`. Chapter 7 will examine all the details of structured exception handling and the use of the `try` and `catch` keywords. Without getting too hung up on the specifics at this point, observe the following update:

```
static void ProcessBytes()
{
    byte b1 = 100;
    byte b2 = 250;
```

```

// This time, tell the compiler to add CIL code
// to throw an exception if overflow/underflow
// takes place.
try
{
    byte sum = checked((byte)Add(b1, b2));
    Console.WriteLine("sum = {0}", sum);
}
catch (OverflowException ex)
{
    Console.WriteLine(ex.Message);
}
}

```

Notice that the return value of `Add()` has been wrapped within the scope of the `checked` keyword. Because the sum is greater than a byte, this triggers a runtime exception. Notice the error message printed out via the `Message` property.

Arithmetic operation resulted in an overflow.

If you want to force overflow checking to occur over a block of code statements, you can do so by defining a “checked scope” as follows:

```

try
{
    checked
    {
        byte sum = (byte)Add(b1, b2);
        Console.WriteLine("sum = {0}", sum);
    }
}
catch (OverflowException ex)
{
    Console.WriteLine(ex.Message);
}
}

```

In either case, the code in question will be evaluated for possible overflow conditions automatically, which will trigger an overflow exception if encountered.

Setting Project-wide Overflow Checking

If you are creating an application that should never allow silent overflow to occur, you might find yourself in the annoying position of wrapping numerous lines of code within the scope of the `checked` keyword. As an alternative, the C# compiler supports the `/checked` flag. When enabled, all your arithmetic will be evaluated for overflow without the need to make use of the C# `checked` keyword. If overflow has been discovered, you will still receive a runtime exception.

To enable this flag using Visual Studio, open your project’s property page and click the `Advanced` button on the `Build` tab. From the resulting dialog box, select the “Check for arithmetic overflow/underflow” check box (see Figure 3-3).

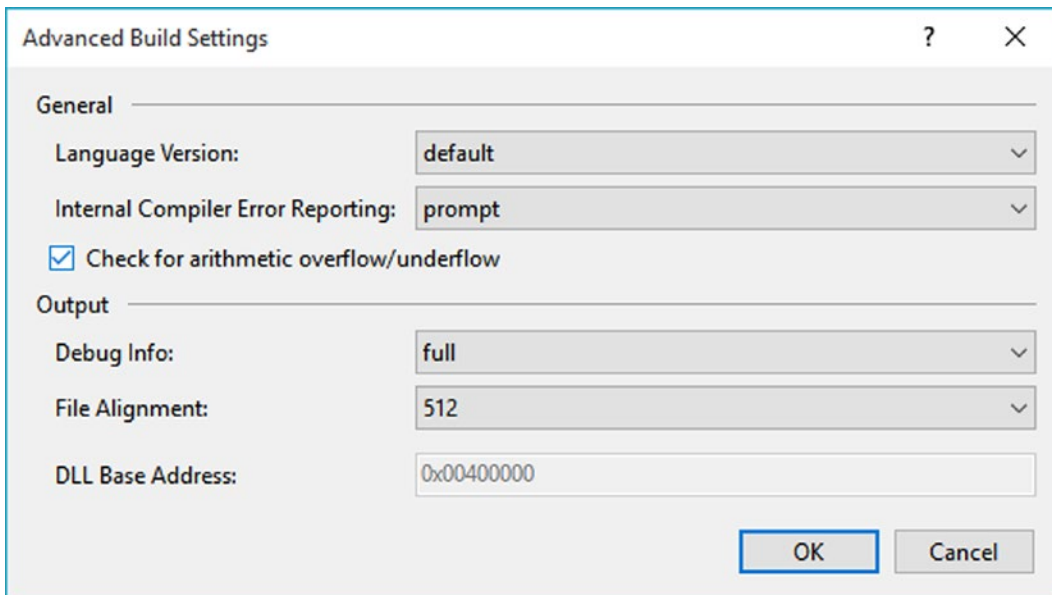

Figure 3-3. Enabling project-wide overflow/underflow data checking

Enabling this setting can be helpful when you're creating a debug build. After all the overflow exceptions have been squashed out of the code base, you're free to disable the `/checked` flag for subsequent builds (which can increase the runtime performance of your application).

The unchecked Keyword

Now, assuming you have enabled this project-wide setting, what are you to do if you have a block of code where data loss *is* acceptable? Given that the `/checked` flag will evaluate all arithmetic logic, C# provides the `unchecked` keyword to disable the throwing of an overflow exception on a case-by-case basis. This keyword's use is identical to that of the `checked` keyword in that you can specify a single statement or a block of statements.

```
// Assuming /checked is enabled,
// this block will not trigger
// a runtime exception.
unchecked
{
    byte sum = (byte)(b1 + b2);
    Console.WriteLine("sum = {0} ", sum);
}
```

So, to summarize the C# `checked` and `unchecked` keywords, remember that the default behavior of the .NET runtime is to ignore arithmetic overflow/underflow. When you want to selectively handle discrete statements, make use of the `checked` keyword. If you want to trap overflow errors throughout your application, enable the `/checked` flag. Finally, the `unchecked` keyword can be used if you have a block of code where overflow is acceptable (and thus should not trigger a runtime exception).

■ **Source Code** The TypeConversions project is located in the Chapter 3 subdirectory.

Understanding Implicitly Typed Local Variables

Up until this point in the chapter, when you have been defining local variables, you've *explicitly* specified the underlying data type of each variable being declared.

```
static void DeclareExplicitVars()
{
    // Explicitly typed local variables
    // are declared as follows:
    // dataType variableName = initialValue;
    int myInt = 0;
    bool myBool = true;
    string myString = "Time, marches on...";
}
```

While many (including yours truly) would argue that it is always good practice to explicitly specify the data type of each variable, the C# language does provide for *implicitly typing* of local variables using the `var` keyword. The `var` keyword can be used in place of specifying a specific data type (such as `int`, `bool`, or `string`). When you do so, the compiler will automatically infer the underlying data type based on the initial value used to initialize the local data point.

To illustrate the role of implicit typing, create a new Console Application project named `ImplicitlyTypedLocalVars`. Notice how the local variables within the previous method can now be declared as follows:

```
static void DeclareImplicitVars()
{
    // Implicitly typed local variables
    // are declared as follows:
    // var variableName = initialValue;
    var myInt = 0;
    var myBool = true;
    var myString = "Time, marches on...";
}
```

■ **Note** Strictly speaking, `var` is not a C# keyword. It is permissible to declare variables, parameters, and fields named `var` without compile-time errors. However, when the `var` token is used as a data type, it is contextually treated as a keyword by the compiler.

In this case, the compiler is able to infer, given the initially assigned value, that `myInt` is, in fact, a `System.Int32`, `myBool` is a `System.Boolean`, and `myString` is indeed of type `System.String`. You can verify this by printing the type name via *reflection*. As you will see in much more detail in Chapter 15, *reflection* is the act of determining the composition of a type at runtime. For example, using reflection, you can

determine the data type of an implicitly typed local variable. Update your method with the following code statements:

```
static void DeclareImplicitVars()
{
    // Implicitly typed local variables.
    var myInt = 0;
    var myBool = true;
    var myString = "Time, marches on...";

    // Print out the underlying type.
    Console.WriteLine("myInt is a: {0}", myInt.GetType().Name);
    Console.WriteLine("myBool is a: {0}", myBool.GetType().Name);
    Console.WriteLine("myString is a: {0}", myString.GetType().Name);
}
```

■ **Note** Be aware that you can use this implicit typing for any type including arrays, generic types (see Chapter 9), and your own custom types. You'll see other examples of implicit typing over the course of this book.

If you were to call the `DeclareImplicitVars()` method from within `Main()`, you'd find the output shown here:

```
***** Fun with Implicit Typing *****

myInt is a: Int32
myBool is a: Boolean
myString is a: String
```

Restrictions on Implicitly Typed Variables

There are various restrictions regarding the use of the `var` keyword. First, implicit typing applies *only* to local variables in a method or property scope. It is illegal to use the `var` keyword to define return values, parameters, or field data of a custom type. For example, the following class definition will result in various compile-time errors:

```
class ThisWillNeverCompile
{
    // Error! var cannot be used as field data!
    private var myInt = 10;

    // Error! var cannot be used as a return value
    // or parameter type!
    public var MyMethod(var x, var y){}
}
```

Also, local variables declared with the `var` keyword *must* be assigned an initial value at the exact time of declaration and *cannot* be assigned the initial value of `null`. This last restriction should make sense, given that the compiler cannot infer what sort of type in memory the variable would be pointing to based only on `null`.

```
// Error! Must assign a value!
var myData;

// Error! Must assign value at exact time of declaration!
var myInt;
myInt = 0;

// Error! Can't assign null as initial value!
var myObj = null;
```

It is permissible, however, to assign an inferred local variable to `null` after its initial assignment (provided it is a reference type).

```
// OK, if SportsCar is a reference type!
var myCar = new SportsCar();
myCar = null;
```

Furthermore, it is permissible to assign the value of an implicitly typed local variable to the value of other variables, implicitly typed or not.

```
// Also OK!
var myInt = 0;
var anotherInt = myInt;

string myString = "Wake up!";
var myData = myString;
```

Also, it is permissible to return an implicitly typed local variable to the caller, provided the method return type is the same underlying type as the `var`-defined data point.

```
static int GetAnInt()
{
    var retVal = 9;
    return retVal;
}
```

Implicit Typed Data Is Strongly Typed Data

Be aware that implicit typing of local variables results in *strongly typed data*. Therefore, use of the `var` keyword is *not* the same technique used with scripting languages (such as JavaScript or Perl) or the COM Variant data type, where a variable can hold values of different types over its lifetime in a program (often termed *dynamic typing*).

■ **Note** C# does allow for dynamic typing in C# using a keyword called—surprise, surprise—`dynamic`. You will learn about this aspect of the language in Chapter 16.

Rather, type inference keeps the strongly typed aspect of the C# language and affects only the declaration of variables at compile time. After that, the data point is treated as if it were declared with that type; assigning a value of a different type into that variable will result in a compile-time error.

```
static void ImplicitTypingIsStrongTyping()
{
    // The compiler knows "s" is a System.String.
    var s = "This variable can only hold string data!";
    s = "This is fine...";

    // Can invoke any member of the underlying type.
    string upper = s.ToUpper();

    // Error! Can't assign numerical data to a string!
    s = 44;
}
```

Usefulness of Implicitly Typed Local Variables

Now that you have seen the syntax used to declare implicitly typed local variables, I am sure you are wondering when to make use of this construct. First, using `var` to declare local variables simply for the sake of doing so brings little to the table. Doing so can be confusing to others reading your code because it becomes harder to quickly determine the underlying data type and, therefore, more difficult to understand the overall functionality of the variable. So, if you know you need an `int`, declare an `int`!

However, as you will see beginning in Chapter 12, the LINQ technology set makes use of *query expressions* that can yield dynamically created result sets based on the format of the query itself. In these cases, implicit typing is extremely helpful because you do not need to explicitly define the type that a query may return, which in some cases would be literally impossible to do. Without getting hung up on the following LINQ example code, see whether you can figure out the underlying data type of `subset`:

```
static void LinqQueryOverInts()
{
    int[] numbers = { 10, 20, 30, 40, 1, 2, 3, 8 };

    // LINQ query!
    var subset = from i in numbers where i < 10 select i;

    Console.Write("Values in subset: ");
    foreach (var i in subset)
    {
        Console.Write("{0} ", i);
    }
    Console.WriteLine();

    // Hmm...what type is subset?
    Console.WriteLine("subset is a: {0}", subset.GetType().Name);
    Console.WriteLine("subset is defined in: {0}", subset.GetType().Namespace);
}
```

You might be assuming that the `subset` data type is an array of integers. That seems to be the case, but, in fact, it is a low level LINQ data type that you would never know about unless you have been doing LINQ for a long time or you open the compiled image in `ildasm.exe`. The good news is that when you are using LINQ, you seldom (if ever) care about the underlying type of the query's return value; you will simply assign the value to an implicitly typed local variable.

In fact, it could be argued that the *only time* you would make use of the `var` keyword is when defining data returned from a LINQ query. Remember, if you know you need an `int`, just declare an `int`! Overuse of implicit typing (via the `var` keyword) is considered by most developers to be poor style in production code.

■ **Source Code** The `ImplicitlyTypedLocalVars` project can be found in the [Chapter 3](#) subdirectory.

C# Iteration Constructs

All programming languages provide ways to repeat blocks of code until a terminating condition has been met. Regardless of which language you have used in the past, I would guess the C# iteration statements should not raise too many eyebrows and should require little explanation. C# provides the following four iteration constructs:

- `for` loop
- `foreach/in` loop
- `while` loop
- `do/while` loop

Let's quickly examine each looping construct in turn, using a new Console Application project named `IterationsAndDecisions`.

■ **Note** I will keep this final section of the chapter short and to the point, as I am assuming you have experience using similar keywords (`if`, `for`, `switch`, etc.) in your current programming language. If you require more information, look up the topics "Iteration Statements (C# Reference)," "Jump Statements (C# Reference)," and "Selection Statements (C# Reference)" within the .NET Framework 4.6 SDK documentation.

The for Loop

When you need to iterate over a block of code a fixed number of times, the `for` statement provides a good deal of flexibility. In essence, you are able to specify how many times a block of code repeats itself, as well as the terminating condition. Without belaboring the point, here is a sample of the syntax:

```
// A basic for loop.
static void ForLoopExample()
{
    // Note! "i" is only visible within the scope of the for loop.
    for(int i = 0; i < 4; i++)
```

```

{
    Console.WriteLine("Number is: {0} ", i);
}
// "i" is not visible here.
}

```

All your old C, C++, and Java tricks still hold when building a C# for statement. You can create complex terminating conditions, build endless loops, loop in reverse (via the -- operator), and use the goto, continue, and break jump keywords.

The foreach Loop

The C# foreach keyword allows you to iterate over all items in a container without the need to test for an upper limit. Unlike a for loop, however, the foreach loop will walk the container only in a linear (n+1) fashion (thus, you cannot go backward through the container, skip every third element, or whatnot).

However, when you simply need to walk a collection item by item, the foreach loop is the perfect choice. Here are two examples using foreach—one to traverse an array of strings and the other to traverse an array of integers. Notice that the data type before the in keyword represents the type of data in the container.

```

// Iterate array items using foreach.
static void ForEachLoopExample()
{
    string[] carTypes = {"Ford", "BMW", "Yugo", "Honda" };
    foreach (string c in carTypes)
        Console.WriteLine(c);

    int[] myInts = { 10, 20, 30, 40 };
    foreach (int i in myInts)
        Console.WriteLine(i);
}

```

The item after the in keyword can be a simple array (seen here) or, more specifically, any class implementing the IEnumerable interface. As you will see in Chapter 9, the .NET base class libraries ship with a number of collections that contain implementations of common abstract data types (ADTs). Any of these items (such as the generic List<T>) can be used within a foreach loop.

Use of Implicit Typing Within foreach Constructs

It is also possible to use implicit typing within a foreach looping construct. As you would expect, the compiler will correctly infer the correct “type of type.” Recall the LINQ example method shown earlier in this chapter. Given that you don’t know the exact underlying data type of the subset variable, you can iterate over the result set using implicit typing.

```

static void LinqQueryOverInts()
{
    int[] numbers = { 10, 20, 30, 40, 1, 2, 3, 8 };

    // LINQ query!
    var subset = from i in numbers where i < 10 select i;
    Console.Write("Values in subset: ");
}

```

```

foreach (var i in subset)
{
    Console.Write("{0} ", i);
}
}

```

The while and do/while Looping Constructs

The while looping construct is useful should you want to execute a block of statements until some terminating condition has been reached. Within the scope of a while loop, you will need to ensure this terminating event is indeed established; otherwise, you will be stuck in an endless loop. In the following example, the message "In while loop" will be continuously printed until the user terminates the loop by entering yes at the command prompt:

```

static void WhileLoopExample()
{
    string userIsDone = "";

    // Test on a lower-class copy of the string.
    while(userIsDone.ToLower() != "yes")
    {
        Console.WriteLine("In while loop");
        Console.Write("Are you done? [yes] [no]: ");
        userIsDone = Console.ReadLine();
    }
}

```

Closely related to the while loop is the do/while statement. Like a simple while loop, do/while is used when you need to perform some action an undetermined number of times. The difference is that do/while loops are guaranteed to execute the corresponding block of code at least once. In contrast, it is possible that a simple while loop may never execute if the terminating condition is false from the onset.

```

static void DoWhileLoopExample()
{
    string userIsDone = "";

    do
    {
        Console.WriteLine("In do/while loop");
        Console.Write("Are you done? [yes] [no]: ");
        userIsDone = Console.ReadLine();
    }while(userIsDone.ToLower() != "yes"); // Note the semicolon!
}

```

Decision Constructs and the Relational/Equality Operators

Now that you can iterate over a block of statements, the next related concept is how to control the flow of program execution. C# defines two simple constructs to alter the flow of your program, based on various contingencies.

- The if/else statement
- The switch statement

The if/else Statement

First up is the if/else statement. Unlike in C and C++, the if/else statement in C# operates only on Boolean expressions, not ad hoc values such as -1 or 0.

Equality and Relational Operators

C# if/else statements typically involve the use of the C# operators shown in Table 3-7 to obtain a literal Boolean value.

Table 3-7. C# Relational and Equality Operators

| C# Equality/Relational Operator | Example Usage | Meaning in Life |
|---------------------------------|--------------------|---|
| == | if(age == 30) | Returns true only if each expression is the same |
| != | if("Foo" != myStr) | Returns true only if each expression is different |
| < | if(bonus < 2000) | Returns true if expression A (bonus) is less than, greater than, less than or equal to, or greater than or equal to expression B (2000) |
| > | if(bonus > 2000) | |
| <= | if(bonus <= 2000) | |
| >= | if(bonus >= 2000) | |

Again, C and C++ programmers need to be aware that the old tricks of testing a condition for a value not equal to zero will not work in C#. Let's say you want to see whether the string you are working with is longer than zero characters. You might be tempted to write this:

```
static void IfElseExample()
{
    // This is illegal, given that Length returns an int, not a bool.
    string stringData = "My textual data";
    if(stringData.Length)
    {
        Console.WriteLine("string is greater than 0 characters");
    }
}
```

If you want to use the `String.Length` property to determine truth or falsity, you need to modify your conditional expression to resolve to a `Boolean`.

```
// legal, as this resolves to either true or false.
if(stringData.Length > 0)
{
    Console.WriteLine("string is greater than 0 characters");
}
```

Conditional Operators

An `if` statement may be composed of complex expressions as well and can contain `else` statements to perform more complex testing. The syntax is identical to C++ and Java. To build complex expressions, C# offers an expected set of conditional logical operators, as shown in Table 3-8.

Table 3-8. C# Conditional Operators

| Operator | Example | Meaning in Life |
|-------------------------|--|---|
| <code>&&</code> | <code>if(age == 30 && name == "Fred")</code> | AND operator. Returns true if all expressions are true. |
| <code> </code> | <code>if(age == 30 name == "Fred")</code> | OR operator. Returns true if at least one expression is true. |
| <code>!</code> | <code>if(!myBool)</code> | NOT operator. Returns true if false, or false if true. |

■ **Note** The `&&` and `||` operators both “short circuit” when necessary. This means that after a complex expression has been determined to be false, the remaining subexpressions will not be checked. If you require all expressions to be tested regardless, you can use the related `&` and `|` operators.

The switch Statement

The other simple selection construct offered by C# is the `switch` statement. As in other C-based languages, the `switch` statement allows you to handle program flow based on a predefined set of choices. For example, the following `Main()` logic prints a specific string message based on one of two possible selections (the default case handles an invalid selection).

```
// Switch on a numerical value.
static void SwitchExample()
{
    Console.WriteLine("1 [C#], 2 [VB]");
    Console.Write("Please pick your language preference: ");

    string langChoice = Console.ReadLine();
    int n = int.Parse(langChoice);
```

```

switch (n)
{
    case 1:
        Console.WriteLine("Good choice, C# is a fine language.");
        break;
    case 2:
        Console.WriteLine("VB: OOP, multithreading, and more!");
        break;
    default:
        Console.WriteLine("Well...good luck with that!");
        break;
}
}

```

■ **Note** C# demands that each case (including default) that contains executable statements have a terminating `break` or `goto` to avoid fall-through.

One nice feature of the C# `switch` statement is that you can evaluate string data in addition to numeric data. Here is an updated `switch` statement that does this very thing (notice there is no need to parse the user data into a numeric value with this approach):

```

static void SwitchOnStringExample()
{
    Console.WriteLine("C# or VB");
    Console.Write("Please pick your language preference: ");

    string langChoice = Console.ReadLine();
    switch (langChoice)
    {
        case "C#":
            Console.WriteLine("Good choice, C# is a fine language.");
            break;
        case "VB":
            Console.WriteLine("VB: OOP, multithreading and more!");
            break;
        default:
            Console.WriteLine("Well...good luck with that!");
            break;
    }
}
}

```

It is also possible to switch on an enumeration data type. As you will see in Chapter 4, the C# `enum` keyword allows you to define a custom set of name-value pairs. To whet your appetite, consider the following final helper function, which performs a switch test on the `System.DayOfWeek` enum. You'll notice some syntax I have not yet examined, but focus on the issue of switching over the enum itself; the missing pieces will be filled in over the chapters to come.

```
static void SwitchOnEnumExample()
{
    Console.Write("Enter your favorite day of the week: ");
    DayOfWeek favDay;

    try
    {
        favDay = (DayOfWeek)Enum.Parse(typeof(DayOfWeek), Console.ReadLine());
    }
    catch (Exception)
    {
        Console.WriteLine("Bad input!");
        return;
    }

    switch (favDay)
    {
        case DayOfWeek.Friday:
            Console.WriteLine("Yes, Friday rules!");
            break;
        case DayOfWeek.Monday:
            Console.WriteLine("Another day, another dollar");
            break;
        case DayOfWeek.Saturday:
            Console.WriteLine("Great day indeed.");
            break;
        case DayOfWeek.Sunday:
            Console.WriteLine("Football!!");
            break;
        case DayOfWeek.Thursday:
            Console.WriteLine("Almost Friday...");
            break;
        case DayOfWeek.Tuesday:
            Console.WriteLine("At least it is not Monday");
            break;
        case DayOfWeek.Wednesday:
            Console.WriteLine("A fine day.");
            break;
    }
}
```

■ **Source Code** The `IterationsAndDecisions` project is located in the Chapter 3 subdirectory.

Summary

The goal of this chapter was to expose you to numerous core aspects of the C# programming language. You examined the commonplace constructs in any application you may be interested in building. After examining the role of an application object, you learned that every C# executable program must have a type defining a `Main()` method, which serves as the program's entry point. Within the scope of `Main()`, you typically create any number of objects that work together to breathe life into your application.

Next, you dove into the details of the built-in data types of C# and came to understand that each data type keyword (e.g., `int`) is really a shorthand notation for a full-blown type in the `System` namespace (`System.Int32`, in this case). Given this, each C# data type has a number of built-in members. Along the same vein, you also learned about the role of *widening* and *narrowing*, as well as the role of the checked and unchecked keywords.

The chapter wrapped up by covering the role of implicit typing using the `var` keyword. As discussed, the most useful place for implicit typing is when working with the LINQ programming model. Finally, you quickly examined the various iteration and decision constructs supported by C#.

Now that you have an understanding of some of the basic nuts and bolts, the next chapter (Chapter 4) will complete your examination of core language features. After that, you will be well prepared to examine the object-oriented features of C# beginning in Chapter 5.

CHAPTER 4



Core C# Programming Constructs, Part II

This chapter picks up where the Chapter 3 left off and completes your investigation of the core aspects of the C# programming language. You will begin by examining various details regarding the construction of C# methods, exploring the `out`, `ref`, and `params` keywords. Along the way, you will also examine the role of optional and named parameters.

After you examine the topic of *method overloading*, the next task is to investigate the details behind manipulating arrays using the syntax of C# and get to know the functionality contained within the related `System.Array` class type.

In addition, this chapter discusses the construction of enumeration and structure types, including a fairly detailed examination of the distinction between a *value type* and a *reference type*. This chapter wraps up by examining the role of *nullable* data types and the related operators.

After you have completed this chapter, you will be in a perfect position to learn the object-oriented capabilities of C#, beginning in Chapter 5.

Methods and Parameter Modifiers

To begin this chapter, let's examine the details of defining methods. Just like the `Main()` method (see Chapter 3), your custom methods may or may not take parameters and may or may not return values to the caller. As you will see over the next several chapters, methods can be implemented within the scope of classes or structures (as well as prototyped within interface types) and may be decorated with various keywords (e.g., `static`, `virtual`, `public`, `new`) to qualify their behavior. At this point in the text, each of your methods has followed the following basic format:

```
// Recall that static methods can be called directly
// without creating a class instance.
class Program
{
    // static returnType MethodName(paramater list) { /* Implementation */ }
    static int Add(int x, int y){ return x + y; }
}
```

While the definition of a method in C# is quite straightforward, you can use a handful of methods to control how arguments are passed to the method in question, as listed in Table 4-1.

Table 4-1. C# Parameter Modifiers

| Parameter Modifier | Meaning in Life |
|--------------------|--|
| (None) | If a parameter is not marked with a parameter modifier, it is assumed to be passed by value, meaning the called method receives a copy of the original data. |
| out | Output parameters must be assigned by the method being called and, therefore, are passed by reference. If the called method fails to assign output parameters, you are issued a compiler error. |
| ref | The value is initially assigned by the caller and may be optionally modified by the called method (as the data is also passed by reference). No compiler error is generated if the called method fails to assign a ref parameter. |
| params | This parameter modifier allows you to send in a variable number of arguments as a single logical parameter. A method can have only a single params modifier, and it must be the final parameter of the method. In reality, you might not need to use the params modifier all too often; however, be aware that numerous methods within the base class libraries do make use of this C# language feature. |

To illustrate the use of these keywords, create a new Console Application project named FunWithMethods. Now, let's walk through the role of each keyword.

The Default by Value Parameter-Passing Behavior

The default manner in which a parameter is sent into a function is *by value*. Simply put, if you do not mark an argument with a parameter modifier, a copy of the data is passed into the function. As explained at the end of this chapter, exactly *what* is copied will depend on whether the parameter is a value type or a reference type. For the time being, assume the following method within the Program class that operates on two numerical data types passed by value:

```
// Arguments are passed by value by default.
static int Add(int x, int y)
{
    int ans = x + y;
    // Caller will not see these changes
    // as you are modifying a copy of the
    // original data.
    x = 10000;
    y = 88888;
    return ans;
}
```

Numerical data falls under the category of *value types*. Therefore, if you change the values of the parameters within the scope of the member, the caller is blissfully unaware, given that you are changing the values on a *copy* of the caller's original data.

```

static void Main(string[] args)
{
    Console.WriteLine("***** Fun with Methods *****\n");

    // Pass two variables in by value.
    int x = 9, y = 10;
    Console.WriteLine("Before call: X: {0}, Y: {1}", x, y);
    Console.WriteLine("Answer is: {0}", Add(x, y));
    Console.WriteLine("After call: X: {0}, Y: {1}", x, y);
    Console.ReadLine();
}

```

As you would hope, the values of *x* and *y* remain identical before and after the call to `Add()`, as shown in the following output, as the data points were sent in by value. Thus, any changes on these parameters within the `Add()` method are not seen by the caller, as the `Add()` method is operating on a copy of the data.

```

***** Fun with Methods *****

Before call: X: 9, Y: 10
Answer is: 19
After call: X: 9, Y: 10

```

The out Modifier

Next, you have the use of *output parameters*. Methods that have been defined to take output parameters (via the `out` keyword) are under obligation to assign them to an appropriate value before exiting the method scope (if you fail to do so, you will receive compiler errors).

To illustrate, here is an alternative version of the `Add()` method that returns the sum of two integers using the C# `out` modifier (note the physical return value of this method is now `void`):

```

// Output parameters must be assigned by the called method.
static void Add(int x, int y, out int ans)
{
    ans = x + y;
}

```

Calling a method with output parameters also requires the use of the `out` modifier. However, the local variables that are passed as output variables are not required to be assigned before passing them in as output arguments (if you do so, the original value is lost after the call). The reason the compiler allows you to send in seemingly unassigned data is because the method being called *must* make an assignment. The following code is an example:

```

static void Main(string[] args)
{
    Console.WriteLine("***** Fun with Methods *****");
    ...
    // No need to assign initial value to local variables
    // used as output parameters, provided the first time
    // you use them is as output arguments.
}

```

```

int ans;
Add(90, 90, out ans);
Console.WriteLine("90 + 90 = {0}", ans);
Console.ReadLine();
}

```

The previous example is intended to be illustrative in nature; you really have no reason to return the value of your summation using an output parameter. However, the C# `out` modifier does serve a useful purpose: it allows the caller to obtain multiple outputs from a single method invocation.

```

// Returning multiple output parameters.
static void FillTheseValues(out int a, out string b, out bool c)
{
    a = 9;
    b = "Enjoy your string.";
    c = true;
}

```

The caller would be able to invoke the `FillTheseValues()` method. Remember that you must use the `out` modifier when you invoke the method, as well as when you implement the method.

```

static void Main(string[] args)
{
    Console.WriteLine("***** Fun with Methods *****");
    ...
    int i; string str; bool b;
    FillTheseValues(out i, out str, out b);

    Console.WriteLine("Int is: {0}", i);
    Console.WriteLine("String is: {0}", str);
    Console.WriteLine("Boolean is: {0}", b);
    Console.ReadLine();
}

```

Finally, always remember that a method that defines output parameters must assign the parameter to a valid value before exiting the method scope. Therefore, the following code will result in a compiler error, as the output parameter has not been assigned within the method scope:

```

static void ThisWontCompile(out int a)
{
    Console.WriteLine("Error! Forgot to assign output arg!");
}

```

The ref Modifier

Now consider the use of the C# `ref` parameter modifier. Reference parameters are necessary when you want to allow a method to operate on (and usually change the values of) various data points declared in the caller's scope (such as a sorting or swapping routine). Note the distinction between output and reference parameters.

- Output parameters do not need to be initialized before they are passed to the method. The reason for this is that the method must assign output parameters before exiting.
- Reference parameters must be initialized before they are passed to the method. The reason for this is that you are passing a reference to an existing variable. If you don't assign it to an initial value, that would be the equivalent of operating on an unassigned local variable.

Let's check out the use of the `ref` keyword by way of a method that swaps two string variables (of course, any two data types could be used here, including `int`, `bool`, `float`, and so on).

```
// Reference parameters.
public static void SwapStrings(ref string s1, ref string s2)
{
    string tempStr = s1;
    s1 = s2;
    s2 = tempStr;
}
```

This method can be called as follows:

```
static void Main(string[] args)
{
    Console.WriteLine("***** Fun with Methods *****");
    ...
    string str1 = "Flip";
    string str2 = "Flop";
    Console.WriteLine("Before: {0}, {1} ", str1, str2);
    SwapStrings(ref str1, ref str2);
    Console.WriteLine("After: {0}, {1} ", str1, str2);
    Console.ReadLine();
}
```

Here, the caller has assigned an initial value to local string data (`str1` and `str2`). After the call to `SwapStrings()` returns, `str1` now contains the value "Flop", while `str2` reports the value "Flip".

```
Before: Flip, Flop
After: Flop, Flip
```

■ **Note** The C# `ref` keyword will be revisited later in this chapter in the section “Understanding Value Types and Reference Types.” As you will see, the behavior of this keyword changes just a bit depending on whether the argument is a value type or reference type.

The params Modifier

C# supports the use of *parameter arrays* using the `params` keyword. To understand this language feature, you must (as the name implies) understand how to manipulate C# arrays. If this is not the case, you might want to return to this section after you read the section “Understanding C# Arrays” later in this chapter.

The `params` keyword allows you to pass into a method a variable number of identically typed parameters (or classes related by inheritance) as a *single logical parameter*. As well, arguments marked with the `params` keyword can be processed if the caller sends in a strongly typed array or a comma-delimited list of items. Yes, this can be confusing! To clear things up, assume you want to create a function that allows the caller to pass in any number of arguments and return the calculated average.

If you were to prototype this method to take an array of doubles, this would force the caller to first define the array, then fill the array, and finally pass it into the method. However, if you define `CalculateAverage()` to take a `params` of `double[]` data types, the caller can simply pass a comma-delimited list of doubles. The .NET runtime will automatically package the set of doubles into an array of type `double` behind the scenes.

```
// Return average of "some number" of doubles.
static double CalculateAverage(params double[] values)
{
    Console.WriteLine("You sent me {0} doubles.", values.Length);

    double sum = 0;
    if(values.Length == 0)
        return sum;
    for (int i = 0; i < values.Length; i++)
        sum += values[i];
    return (sum / values.Length);
}
```

This method has been defined to take a parameter array of doubles. What this method is in fact saying is, “Send me any number of doubles (including zero), and I’ll compute the average.” Given this, you can call `CalculateAverage()` in any of the following ways:

```
static void Main(string[] args)
{
    Console.WriteLine("***** Fun with Methods *****");
    ...
    // Pass in a comma-delimited list of doubles..
    double average;
    average = CalculateAverage(4.0, 3.2, 5.7, 64.22, 87.2);
    Console.WriteLine("Average of data is: {0}", average);

    // ...or pass an array of doubles.
    double[] data = { 4.0, 3.2, 5.7 };
    average = CalculateAverage(data);
    Console.WriteLine("Average of data is: {0}", average);

    // Average of 0 is 0!
    Console.WriteLine("Average of data is: {0}", CalculateAverage());
    Console.ReadLine();
}
```

If you did not make use of the `params` modifier in the definition of `CalculateAverage()`, the first invocation of this method would result in a compiler error, as the compiler would be looking for a version of `CalculateAverage()` that took five `double` arguments.

■ **Note** To avoid any ambiguity, C# demands a method support only a single `params` argument, which must be the final argument in the parameter list.

As you might guess, this technique is nothing more than a convenience for the caller, given that the array is created by the CLR as necessary. By the time the array is within the scope of the method being called, you are able to treat it as a full-blown .NET array that contains all the functionality of the `System.Array` base class library type. Consider the following output:

```
You sent me 5 doubles.
Average of data is: 32.864
You sent me 3 doubles.
Average of data is: 4.3
You sent me 0 doubles.
Average of data is: 0
```

Defining Optional Parameters

C# allows you to create methods that can take *optional arguments*. This technique allows the caller to invoke a single method while omitting arguments deemed unnecessary, provided the caller is happy with the specified defaults.

■ **Note** As you will see in Chapter 16, a key motivation for adding optional arguments to C# is to simplify interacting with COM objects. Several Microsoft object models (e.g., Microsoft Office) expose their functionality via COM objects, many of which were written long ago to make use of optional parameters, which earlier versions of C# did not support.

To illustrate working with optional arguments, assume you have a method named `EnterLogData()`, which defines a single optional parameter.

```
static void EnterLogData(string message, string owner = "Programmer")
{
    Console.Beep();
    Console.WriteLine("Error: {0}", message);
    Console.WriteLine("Owner of Error: {0}", owner);
}
```

Here, the final string argument has been assigned the default value of "Programmer", via an assignment within the parameter definition. Given this, you can call `EnterLogData()` from within `Main()` in two manners.

```
static void Main(string[] args)
{
    Console.WriteLine("***** Fun with Methods *****");
    ...
    EnterLogData("Oh no! Grid can't find data");
    EnterLogData("Oh no! I can't find the payroll data", "CFO");

    Console.ReadLine();
}
```

Because the first invocation of `EnterLogData()` did not specify a second string argument, you would find that the programmer is the one responsible for losing data for the grid, while the CFO misplaced the payroll data (as specified by the second argument in the second method call).

One important thing to be aware of is that the value assigned to an optional parameter must be known at compile time and cannot be resolved at runtime (if you attempt to do so, you'll receive compile-time errors!). To illustrate, assume you want to update `EnterLogData()` with the following extra optional parameter:

```
// Error! The default value for an optional arg must be known
// at compile time!
static void EnterLogData(string message,
                        string owner = "Programmer", DateTime timeStamp = DateTime.Now)
{
    Console.Beep();
    Console.WriteLine("Error: {0}", message);
    Console.WriteLine("Owner of Error: {0}", owner);
    Console.WriteLine("Time of Error: {0}", timeStamp);
}
```

This will not compile because the value of the `Now` property of the `DateTime` class is resolved at runtime, not compile time.

■ **Note** To avoid ambiguity, optional parameters must always be packed onto the *end* of a method signature. It is a compiler error to have optional parameters listed before nonoptional parameters.

Invoking Methods Using Named Parameters

Another language feature found in C# is support for *named arguments*. To be honest, at first glance, this language construct might appear to do little more than result in confusing code. And to continue being completely honest, this could be the case! Similar to optional arguments, including support for named parameters is partially motivated by the desire to simplify the process of working with the COM interoperability layer (again, see Chapter 16).

Named arguments allow you to invoke a method by specifying parameter values in any order you choose. Thus, rather than passing parameters solely by position (as you will do in most cases), you can choose to specify each argument by name using a colon operator. To illustrate the use of named arguments, assume you have added the following method to the `Program` class:

```
static void DisplayFancyMessage(ConsoleColor textColor,
    ConsoleColor backgroundColor, string message)
{
    // Store old colors to restore after message is printed.
    ConsoleColor oldTextColor = Console.ForegroundColor;
    ConsoleColor oldbackgroundColor = Console.BackgroundColor;

    // Set new colors and print message.
    Console.ForegroundColor = textColor;
    Console.BackgroundColor = backgroundColor;
    Console.WriteLine(message);

    // Restore previous colors.
    Console.ForegroundColor = oldTextColor;
    Console.BackgroundColor = oldbackgroundColor;
}
```

Now, the way `DisplayFancyMessage()` was written, you would expect the caller to invoke this method by passing two `ConsoleColor` variables followed by a string type. However, using named arguments, the following calls are completely fine:

```
static void Main(string[] args)
{
    Console.WriteLine("***** Fun with Methods *****");
    ...
    DisplayFancyMessage(message: "Wow! Very Fancy indeed!",
        textColor: ConsoleColor.DarkRed,
        backgroundColor: ConsoleColor.White);

    DisplayFancyMessage(backgroundColor: ConsoleColor.Green,
        message: "Testing...",
        textColor: ConsoleColor.DarkBlue);
    Console.ReadLine();
}
```

One minor “gotcha” regarding named arguments is that if you begin to invoke a method using positional parameters, you must list them before any named parameters. In other words, named arguments must always be packed onto the end of a method call. The following code is an example:

```
// This is OK, as positional args are listed before named args.
DisplayFancyMessage(ConsoleColor.Blue,
    message: "Testing...",
    backgroundColor: ConsoleColor.White);

// This is an ERROR, as positional args are listed after named args.
DisplayFancyMessage(message: "Testing...",
    backgroundColor: ConsoleColor.White,
    ConsoleColor.Blue);
```

This restriction aside, you might still be wondering when you would ever want to use this language feature. After all, if you need to specify three arguments to a method, why bother flipping around their position?

Well, as it turns out, if you have a method that defines optional arguments, this feature can actually be really helpful. Assume `DisplayFancyMessage()` has been rewritten to now support optional arguments, as you have assigned fitting defaults.

```
static void DisplayFancyMessage(ConsoleColor textColor = ConsoleColor.Blue,
    ConsoleColor backgroundColor = ConsoleColor.White,
    string message = "Test Message")
{
    ...
}
```

Given that each argument has a default value, named arguments allow the caller to specify only the parameters for which they do not want to receive the defaults. Therefore, if the caller wants the value "Hello!" to appear in blue text surrounded by a white background, they can simply specify the following:

```
DisplayFancyMessage(message: "Hello!");
```

Or, if the caller wants to see "Test Message" print out with a green background containing blue text, they can invoke `DisplayFancyMessage()`.

```
DisplayFancyMessage(backgroundColor: ConsoleColor.Green);
```

As you can see, optional arguments and named parameters tend to work hand in hand. To wrap up your examination of building C# methods, I need to address the topic of *method overloading*.

■ **Source Code** The `FunWithMethods` application is located in the Chapter 4 subdirectory.

Understanding Method Overloading

Like other modern object-oriented languages, C# allows a method to be *overloaded*. Simply put, when you define a set of identically named methods that differ by the number (or type) of parameters, the method in question is said to be overloaded.

To understand why overloading is so useful, consider life as an old-school Visual Basic 6.0 (VB6) developer. Assume you are using VB6 to build a set of methods that return the sum of various incoming data types (Integers, Doubles, and so on). Given that VB6 does not support method overloading, you would be required to define a unique set of methods that essentially do the same thing (return the sum of the arguments).

' VB6 code examples.

```
Public Function AddInts(ByVal x As Integer, ByVal y As Integer) As Integer
    AddInts = x + y
End Function
```

```
Public Function AddDoubles(ByVal x As Double, ByVal y As Double) As Double
    AddDoubles = x + y
End Function
```

```
Public Function AddLongs(ByVal x As Long, ByVal y As Long) As Long
    AddLongs = x + y
End Function
```

Not only can code such as this become tough to maintain, but the caller must now be painfully aware of the name of each method. Using overloading, you are able to allow the caller to call a single method named `Add()`. Again, the key is to ensure that each version of the method has a distinct set of arguments (methods differing only by return type are not unique enough).

■ **Note** As explained in Chapter 9, it is possible to build generic methods that take the concept of overloading to the next level. Using generics, you can define *type placeholders* for a method implementation that are specified at the time you invoke the member in question.

To check this out firsthand, create a new Console Application project named `MethodOverloading`. Now, consider the following class definition:

```
// C# code.
class Program
{
    static void Main(string[] args)
    {
    }

    // Overloaded Add() method.
    static int Add(int x, int y)
    { return x + y; }

    static double Add(double x, double y)
    { return x + y; }

    static long Add(long x, long y)
    { return x + y; }
}
```

The caller can now simply invoke `Add()` with the required arguments, and the compiler is happy to comply, given that the compiler is able to resolve the correct implementation to invoke with the provided arguments.

```
static void Main(string[] args)
{
    Console.WriteLine("***** Fun with Method Overloading *****\n");

    // Calls int version of Add()
    Console.WriteLine(Add(10, 10));

    // Calls long version of Add()
    Console.WriteLine(Add(900000000000, 900000000000));
}
```

```
// Calls double version of Add()
Console.WriteLine(Add(4.3, 4.4));

Console.ReadLine();
}
```

The Visual Studio IDE provides assistance when calling overloaded methods to boot. When you type in the name of an overloaded method (such as your good friend `Console.WriteLine()`), IntelliSense will list each version of the method in question. Note that you are able to cycle through each version of an overloaded method using the up and down arrow keys shown in Figure 4-1.

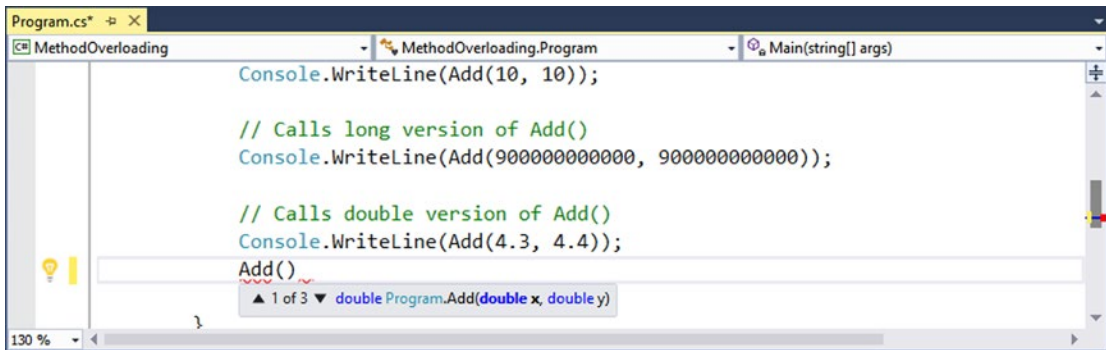

Figure 4-1. Visual Studio IntelliSense for overloaded methods

■ **Source Code** The MethodOverloading application is located in the Chapter 4 subdirectory.

That wraps up the initial examination of building methods using the syntax of C#. Next, let's check out how to build and manipulate arrays, enumerations, and structures.

Understanding C# Arrays

As I would guess you are already aware, an *array* is a set of data items, accessed using a numerical index. More specifically, an array is a set of contiguous data points of the same type (an array of ints, an array of strings, an array of `SportsCars`, and so on). Declaring, filling, and accessing an array with C# is quite straightforward. To illustrate, create a new Console Application project (named `FunWithArrays`) that contains a helper method named `SimpleArrays()`, invoked from within `Main()`.

```
class Program
{
    static void Main(string[] args)
    {
        Console.WriteLine("***** Fun with Arrays *****");
        SimpleArrays();
        Console.ReadLine();
    }
}
```



```

static void SimpleArrays()
{
    Console.WriteLine("=> Simple Array Creation.");
    // Create an array of ints containing 3 elements indexed 0, 1, 2
    int[] myInts = new int[3];

    // Create a 100 item string array, indexed 0 - 99
    string[] booksOnDotNet = new string[100];
    Console.WriteLine();
}
}

```

Look closely at the previous code comments. When declaring a C# array using this syntax, the number used in the array declaration represents the total number of items, not the upper bound. Also note that the lower bound of an array always begins at 0. Thus, when you write `int[] myInts = new int[3]`, you end up with an array holding three elements, indexed at positions 0, 1, 2.

After you have defined an array variable, you are then able to fill the elements index by index, as shown here in the updated `SimpleArrays()` method:

```

static void SimpleArrays()
{
    Console.WriteLine("=> Simple Array Creation.");
    // Create and fill an array of 3 Integers
    int[] myInts = new int[3];
    myInts[0] = 100;
    myInts[1] = 200;
    myInts[2] = 300;

    // Now print each value.
    foreach(int i in myInts)
        Console.WriteLine(i);
    Console.WriteLine();
}

```

■ **Note** Do be aware that if you declare an array but do not explicitly fill each index, each item will be set to the default value of the data type (e.g., an array of `bools` will be set to `false` or an array of `ints` will be set to `0`).

C# Array Initialization Syntax

In addition to filling an array element by element, you are also able to fill the items of an array using C# *array initialization syntax*. To do so, specify each array item within the scope of curly brackets (`{}`). This syntax can be helpful when you are creating an array of a known size and want to quickly specify the initial values. For example, consider the following alternative array declarations:

```

static void ArrayInitialization()
{
    Console.WriteLine("=> Array Initialization.");
}

```

```

// Array initialization syntax using the new keyword.
string[] stringArray = new string[]
    { "one", "two", "three" };
Console.WriteLine("stringArray has {0} elements", stringArray.Length);

// Array initialization syntax without using the new keyword.
bool[] boolArray = { false, false, true };
Console.WriteLine("boolArray has {0} elements", boolArray.Length);

// Array initialization with new keyword and size.
int[] intArray = new int[4] { 20, 22, 23, 0 };
Console.WriteLine("intArray has {0} elements", intArray.Length);
Console.WriteLine();
}

```

Notice that when you make use of this “curly-bracket” syntax, you do not need to specify the size of the array (seen when constructing the `stringArray` variable), given that this will be inferred by the number of items within the scope of the curly brackets. Also notice that the use of the `new` keyword is optional (shown when constructing the `boolArray` type).

In the case of the `intArray` declaration, again recall the numeric value specified represents the number of elements in the array, not the value of the upper bound. If there is a mismatch between the declared size and the number of initializers (whether you have too many or too few initializers), you are issued a compile-time error. The following is an example:

```

// OOPS! Mismatch of size and elements!
int[] intArray = new int[2] { 20, 22, 23, 0 };

```

Implicitly Typed Local Arrays

In Chapter 3, you learned about the topic of implicitly typed local variables. Recall that the `var` keyword allows you to define a variable, whose underlying type is determined by the compiler. In a similar vein, the `var` keyword can be used to define *implicitly typed local arrays*. Using this technique, you can allocate a new array variable without specifying the type contained within the array itself (note you must use the `new` keyword when using this approach).

```

static void DeclareImplicitArrays()
{
    Console.WriteLine("=> Implicit Array Initialization.");

    // a is really int[].
    var a = new[] { 1, 10, 100, 1000 };
    Console.WriteLine("a is a: {0}", a.ToString());

    // b is really double[].
    var b = new[] { 1, 1.5, 2, 2.5 };
    Console.WriteLine("b is a: {0}", b.ToString());

    // c is really string[].
    var c = new[] { "hello", null, "world" };
    Console.WriteLine("c is a: {0}", c.ToString());
    Console.WriteLine();
}

```

Of course, just as when you allocate an array using explicit C# syntax, the items in the array's initialization list must be of the same underlying type (e.g., all ints, all strings, or all SportsCars). Unlike what you might be expecting, an implicitly typed local array does not default to `System.Object`; thus, the following generates a compile-time error:

```
// Error! Mixed types!
var d = new[] { 1, "one", 2, "two", false };
```

Defining an Array of Objects

In most cases, when you define an array, you do so by specifying the explicit type of item that can be within the array variable. While this seems quite straightforward, there is one notable twist. As you will come to understand in Chapter 6, `System.Object` is the ultimate base class to every type (including fundamental data types) in the .NET type system. Given this fact, if you were to define an array of `System.Object` data types, the subitems could be anything at all. Consider the following `ArrayOfObjects()` method (which again can be invoked from `Main()` for testing):

```
static void ArrayOfObjects()
{
    Console.WriteLine("=> Array of Objects.");

    // An array of objects can be anything at all.
    object[] myObjects = new object[4];
    myObjects[0] = 10;
    myObjects[1] = false;
    myObjects[2] = new DateTime(1969, 3, 24);
    myObjects[3] = "Form & Void";
    foreach (object obj in myObjects)
    {
        // Print the type and value for each item in array.
        Console.WriteLine("Type: {0}, Value: {1}", obj.GetType(), obj);
    }
    Console.WriteLine();
}
```

Here, as you are iterating over the contents of `myObjects`, you print the underlying type of each item using the `GetType()` method of `System.Object`, as well as the value of the current item. Without going into too much detail regarding `System.Object.GetType()` at this point in the text, simply understand that this method can be used to obtain the fully qualified name of the item (Chapter 15 examines the topic of type information and reflection services in detail). The following output shows the result of calling `ArrayOfObjects()`:

```
=> Array of Objects.
Type: System.Int32, Value: 10
Type: System.Boolean, Value: False
Type: System.DateTime, Value: 3/24/1969 12:00:00 AM
Type: System.String, Value: Form & Void
```

Working with Multidimensional Arrays

In addition to the single-dimension arrays you have seen thus far, C# also supports two varieties of multidimensional arrays. The first of these is termed a *rectangular array*, which is simply an array of multiple dimensions, where each row is of the same length. To declare and fill a multidimensional rectangular array, proceed as follows:

```
static void RectMultidimensionalArray()
{
    Console.WriteLine("=> Rectangular multidimensional array.");
    // A rectangular MD array.
    int[,] myMatrix;
    myMatrix = new int[3,4];

    // Populate (3 * 4) array.
    for(int i = 0; i < 3; i++)
        for(int j = 0; j < 4; j++)
            myMatrix[i, j] = i * j;

    // Print (3 * 4) array.
    for(int i = 0; i < 3; i++)
    {
        for(int j = 0; j < 4; j++)
            Console.Write(myMatrix[i, j] + "\t");
        Console.WriteLine();
    }
    Console.WriteLine();
}
```

The second type of multidimensional array is termed a *jagged array*. As the name implies, jagged arrays contain some number of inner arrays, each of which may have a different upper limit. Here's an example:

```
static void JaggedMultidimensionalArray()
{
    Console.WriteLine("=> Jagged multidimensional array.");
    // A jagged MD array (i.e., an array of arrays).
    // Here we have an array of 5 different arrays.
    int[][] myJagArray = new int[5][];

    // Create the jagged array.
    for (int i = 0; i < myJagArray.Length; i++)
        myJagArray[i] = new int[i + 7];

    // Print each row (remember, each element is defaulted to zero!).
    for(int i = 0; i < 5; i++)
    {
        for(int j = 0; j < myJagArray[i].Length; j++)
            Console.Write(myJagArray[i][j] + " ");
        Console.WriteLine();
    }
    Console.WriteLine();
}
```

The output of calling each of the `RectMultidimensionalArray()` and `JaggedMultidimensionalArray()` methods within `Main()` is shown next:

=> Rectangular multidimensional array:

```
0    0    0    0
0    1    2    3
0    2    4    6
```

=> Jagged multidimensional array:

```
0 0 0 0 0 0 0
0 0 0 0 0 0 0 0
0 0 0 0 0 0 0 0 0
0 0 0 0 0 0 0 0 0 0
0 0 0 0 0 0 0 0 0 0
```

Arrays As Arguments or Return Values

After you have created an array, you are free to pass it as an argument or receive it as a member return value. For example, the following `PrintArray()` method takes an incoming array of ints and prints each member to the console, while the `GetStringArray()` method populates an array of strings and returns it to the caller:

```
static void PrintArray(int[] myInts)
{
    for(int i = 0; i < myInts.Length; i++)
        Console.WriteLine("Item {0} is {1}", i, myInts[i]);
}

static string[] GetStringArray()
{
    string[] theStrings = {"Hello", "from", "GetStringArray"};
    return theStrings;
}
```

These methods may be invoked as you would expect:

```
static void PassAndReceiveArrays()
{
    Console.WriteLine("=> Arrays as params and return values.");
    // Pass array as parameter.
    int[] ages = {20, 22, 23, 0} ;
    PrintArray(ages);

    // Get array as return value.
    string[] strs = GetStringArray();
    foreach(string s in strs)
        Console.WriteLine(s);

    Console.WriteLine();
}
```

At this point, you should feel comfortable with the process of defining, filling, and examining the contents of a C# array variable. To complete the picture, let's now examine the role of the `System.Array` class.

The `System.Array` Base Class

Every array you create gathers much of its functionality from the `System.Array` class. Using these common members, you are able to operate on an array using a consistent object model. Table 4-2 gives a rundown of some of the more interesting members (be sure to check the .NET Framework 4.6 SDK documentation for full details).

Table 4-2. *Select Members of `System.Array`*

| Member of Array Class | Meaning in Life |
|------------------------|--|
| <code>Clear()</code> | This static method sets a range of elements in the array to empty values (0 for numbers, null for object references, false for Booleans). |
| <code>CopyTo()</code> | This method is used to copy elements from the source array into the destination array. |
| <code>Length</code> | This property returns the number of items within the array. |
| <code>Rank</code> | This property returns the number of dimensions of the current array. |
| <code>Reverse()</code> | This static method reverses the contents of a one-dimensional array. |
| <code>Sort()</code> | This static method sorts a one-dimensional array of intrinsic types. If the elements in the array implement the <code>IComparer</code> interface, you can also sort your custom types (see Chapter 9). |

Let's see some of these members in action. The following helper method makes use of the static `Reverse()` and `Clear()` methods to pump out information about an array of string types to the console:

```
static void SystemArrayFunctionality()
{
    Console.WriteLine("=> Working with System.Array.");
    // Initialize items at startup.
    string[] gothicBands = {"Tones on Tail", "Bauhaus", "Sisters of Mercy"};

    // Print out names in declared order.
    Console.WriteLine("-> Here is the array:");
    for (int i = 0; i < gothicBands.Length; i++)
    {
        // Print a name.
        Console.Write(gothicBands[i] + ", ");
    }
    Console.WriteLine("\n");

    // Reverse them...
    Array.Reverse(gothicBands);
    Console.WriteLine("-> The reversed array");
}
```

```

// ... and print them.
for (int i = 0; i < gothicBands.Length; i++)
{
    // Print a name.
    Console.Write(gothicBands[i] + ", ");
}
Console.WriteLine("\n");

// Clear out all but the first member.
Console.WriteLine("-> Cleared out all but one...");
Array.Clear(gothicBands, 1, 2);

for (int i = 0; i < gothicBands.Length; i++)
{
    // Print a name.
    Console.Write(gothicBands[i] + ", ");
}
Console.WriteLine();
}

```

If you invoke this method from within `Main()`, you will get the output shown here:

```

=> Working with System.Array.
-> Here is the array:
Tones on Tail, Bauhaus, Sisters of Mercy,

-> The reversed array
Sisters of Mercy, Bauhaus, Tones on Tail,

-> Cleared out all but one...
Sisters of Mercy, , ,

```

Notice that many members of `System.Array` are defined as static members and are, therefore, called at the class level (for example, the `Array.Sort()` and `Array.Reverse()` methods). Methods such as these are passed in the array you want to process. Other members of `System.Array` (such as the `Length` property) are bound at the object level; thus, you are able to invoke the member directly on the array.

■ **Source Code** The `FunWithArrays` application is located in the [Chapter 4](#) subdirectory.

Understanding the enum Type

Recall from [Chapter 1](#) that the .NET type system is composed of classes, structures, enumerations, interfaces, and delegates. To begin exploration of these types, let's check out the role of the *enumeration* (or simply, `enum`) using a new Console Application project named `FunWithEnums`.

■ **Note** Do not confuse the term *enum* with *enumerator*; they are completely different concepts. An enum is a custom data type of name-value pairs. An enumerator is a class or structure that implements a .NET interface named `IEnumerable`. Typically, this interface is implemented on collection classes, as well as the `System.Array` class. As you will see later in Chapter 8, objects that support `IEnumerable` can work within the `foreach` loop.

When building a system, it is often convenient to create a set of symbolic names that map to known numerical values. For example, if you are creating a payroll system, you might want to refer to the type of employees using constants such as vice president, manager, contractor, and grunt. C# supports the notion of custom enumerations for this very reason. For example, here is an enumeration named `EmpType` (you can define this in the same file as your `Program` class, right before the class definition):

```
// A custom enumeration.
enum EmpType
{
    Manager,          // = 0
    Grunt,            // = 1
    Contractor,       // = 2
    VicePresident     // = 3
}
```

The `EmpType` enumeration defines four named constants, corresponding to discrete numerical values. By default, the first element is set to the value zero (0), followed by an $n+1$ progression. You are free to change the initial value as you see fit. For example, if it made sense to number the members of `EmpType` as 102 through 105, you could do so as follows:

```
// Begin with 102.
enum EmpType
{
    Manager = 102,
    Grunt,          // = 103
    Contractor,     // = 104
    VicePresident   // = 105
}
```

Enumerations do not necessarily need to follow a sequential ordering and do not need to have unique values. If (for some reason or another) it makes sense to establish your `EmpType` as shown here, the compiler continues to be happy:

```
// Elements of an enumeration need not be sequential!
enum EmpType
{
    Manager = 10,
    Grunt = 1,
    Contractor = 100,
    VicePresident = 9
}
```

Controlling the Underlying Storage for an enum

By default, the storage type used to hold the values of an enumeration is a `System.Int32` (the C# `int`); however, you are free to change this to your liking. C# enumerations can be defined in a similar manner for any of the core system types (`byte`, `short`, `int`, or `long`). For example, if you want to set the underlying storage value of `EmpType` to be a `byte` rather than an `int`, you can write the following:

```
// This time, EmpType maps to an underlying byte.
enum EmpType : byte
{
    Manager = 10,
    Grunt = 1,
    Contractor = 100,
    VicePresident = 9
}
```

Changing the underlying type of an enumeration can be helpful if you are building a .NET application that will be deployed to a low-memory device and need to conserve memory wherever possible. Of course, if you do establish your enumeration to use a `byte` as storage, each value must be within its range! For example, the following version of `EmpType` will result in a compiler error, as the value 999 cannot fit within the range of a `byte`:

```
// Compile-time error! 999 is too big for a byte!
enum EmpType : byte
{
    Manager = 10,
    Grunt = 1,
    Contractor = 100,
    VicePresident = 999
}
```

Declaring enum Variables

Once you have established the range and storage type of your enumeration, you can use it in place of so-called magic numbers. Because enumerations are nothing more than a user-defined data type, you are able to use them as function return values, method parameters, local variables, and so forth. Assume you have a method named `AskForBonus()`, taking an `EmpType` variable as the sole parameter. Based on the value of the incoming parameter, you will print out a fitting response to the pay bonus request.

```
class Program
{
    static void Main(string[] args)
    {
        Console.WriteLine("**** Fun with Enums ****");
        // Make an EmpType variable.
        EmpType emp = EmpType.Contractor;
        AskForBonus(emp);
        Console.ReadLine();
    }
}
```

```
// Enums as parameters.
static void AskForBonus(EmpType e)
{
    switch (e)
    {
        case EmpType.Manager:
            Console.WriteLine("How about stock options instead?");
            break;
        case EmpType.Grunt:
            Console.WriteLine("You have got to be kidding...");
            break;
        case EmpType.Contractor:
            Console.WriteLine("You already get enough cash...");
            break;
        case EmpType.VicePresident:
            Console.WriteLine("VERY GOOD, Sir!");
            break;
    }
}
}
```

Notice that when you are assigning a value to an enum variable, you must scope the enum name (`EmpType`) to the value (`Grunt`). Because enumerations are a fixed set of name-value pairs, it is illegal to set an enum variable to a value that is not defined directly by the enumerated type.

```
static void ThisMethodWillNotCompile()
{
    // Error! SalesManager is not in the EmpType enum!
    EmpType emp = EmpType.SalesManager;

    // Error! Forgot to scope Grunt value to EmpType enum!
    emp = Grunt;
}
```

The System.Enum Type

The interesting thing about .NET enumerations is that they gain functionality from the `System.Enum` class type. This class defines a number of methods that allow you to interrogate and transform a given enumeration. One helpful method is the static `Enum.GetUnderlyingType()`, which, as the name implies, returns the data type used to store the values of the enumerated type (`System.Byte` in the case of the current `EmpType` declaration).

```
static void Main(string[] args)
{
    Console.WriteLine("**** Fun with Enums ****");
    // Make a contractor type.
    EmpType emp = EmpType.Contractor;
    AskForBonus(emp);
}
```

```
// Print storage for the enum.
Console.WriteLine("EmpType uses a {0} for storage",
    Enum.GetUnderlyingType(emp.GetType()));
Console.ReadLine();
}
```

If you were to consult the Visual Studio object browser, you would be able to verify that the `Enum.GetUnderlyingType()` method requires you to pass in a `System.Type` as the first parameter. As fully examined in Chapter 15, `Type` represents the metadata description of a given .NET entity.

One possible way to obtain metadata (as shown previously) is to use the `GetType()` method, which is common to all types in the .NET base class libraries. Another approach is to use the C# `typeof` operator. One benefit of doing so is that you do not need to have a variable of the entity you want to obtain a metadata description of.

```
// This time use typeof to extract a Type.
Console.WriteLine("EmpType uses a {0} for storage",
    Enum.GetUnderlyingType(typeof(EmpType)));
```

Dynamically Discovering an enum's Name/Value Pairs

Beyond the `Enum.GetUnderlyingType()` method, all C# enumerations support a method named `ToString()`, which returns the string name of the current enumeration's value. The following code is an example:

```
static void Main(string[] args)
{
    Console.WriteLine("**** Fun with Enums ****");
    EmpType emp = EmpType.Contractor;
    AskForBonus(emp);

    // Prints out "emp is a Contractor".
    Console.WriteLine("emp is a {0}.", emp.ToString());
    Console.ReadLine();
}
```

If you are interested in discovering the value of a given enumeration variable, rather than its name, you can simply cast the enum variable against the underlying storage type. The following is an example:

```
static void Main(string[] args)
{
    Console.WriteLine("**** Fun with Enums ****");
    EmpType emp = EmpType.Contractor;
    ...

    // Prints out "Contractor = 100".
    Console.WriteLine("{0} = {1}", emp.ToString(), (byte)emp);
    Console.ReadLine();
}
```

■ **Note** The static `Enum.Format()` method provides a finer level of formatting options by specifying a desired format flag. Consult the .NET Framework 4.6 SDK documentation for full details of the `System.Enum.Format()` method.

`System.Enum` also defines another static method named `GetValues()`. This method returns an instance of `System.Array`. Each item in the array corresponds to a member of the specified enumeration. Consider the following method, which will print out each name-value pair within any enumeration you pass in as a parameter:

```
// This method will print out the details of any enum.
static void EvaluateEnum(System.Enum e)
{
    Console.WriteLine("=> Information about {0}", e.GetType().Name);

    Console.WriteLine("Underlying storage type: {0}",
        Enum.GetUnderlyingType(e.GetType()));

    // Get all name/value pairs for incoming parameter.
    Array enumData = Enum.GetValues(e.GetType());
    Console.WriteLine("This enum has {0} members.", enumData.Length);

    // Now show the string name and associated value, using the D format
    // flag (see Chapter 3).
    for(int i = 0; i < enumData.Length; i++)
    {
        Console.WriteLine("Name: {0}, Value: {0:D}",
            enumData.GetValue(i));
    }
    Console.WriteLine();
}
```

To test this new method, update your `Main()` method to create variables of several enumeration types declared in the `System` namespace (as well as an `EmpType` enumeration for good measure). The following code is an example:

```
static void Main(string[] args)
{
    Console.WriteLine("**** Fun with Enums ****");
    ...
    EmpType e2 = EmpType.Contractor;

    // These types are enums in the System namespace.
    DayOfWeek day = DayOfWeek.Monday;
    ConsoleColor cc = ConsoleColor.Gray;

    EvaluateEnum(e2);
    EvaluateEnum(day);
    EvaluateEnum(cc);
    Console.ReadLine();
}
```

Some partial output is shown here:

```
=> Information about DayOfWeek
Underlying storage type: System.Int32
This enum has 7 members.
Name: Sunday, Value: 0
Name: Monday, Value: 1
Name: Tuesday, Value: 2
Name: Wednesday, Value: 3
Name: Thursday, Value: 4
Name: Friday, Value: 5
Name: Saturday, Value: 6
```

As you will see over the course of this text, enumerations are used extensively throughout the .NET base class libraries. For example, ADO.NET makes use of numerous enumerations to represent the state of a database connection (e.g., opened or closed) or the state of a row in a `DataTable` (e.g., changed, new, or detached). Therefore, when you make use of any enumeration, always remember that you are able to interact with the name-value pairs using the members of `System.Enum`.

■ **Source Code** The `FunWithEnums` project is located under the [Chapter 4](#) subdirectory.

Understanding the Structure (aka Value Type)

Now that you understand the role of enumeration types, let's examine the use of .NET *structures* (or simply *structs*). Structure types are well suited for modeling mathematical, geometrical, and other “atomic” entities in your application. A structure (such as an enumeration) is a user-defined type; however, structures are not simply a collection of name-value pairs. Rather, structures are types that can contain any number of data fields and members that operate on these fields.

■ **Note** If you have a background in OOP, you can think of a structure as a “lightweight class type,” given that structures provide a way to define a type that supports encapsulation but cannot be used to build a family of related types. When you need to build a family of related types through inheritance, you will need to make use of class types.

On the surface, the process of defining and using structures is simple, but as they say, the devil is in the details. To begin understanding the basics of structure types, create a new project named `FunWithStructures`. In C#, structures are defined using the `struct` keyword. Define a new structure named `Point`, which defines two member variables of type `int` and a set of methods to interact with said data.

```
struct Point
{
    // Fields of the structure.
    public int X;
    public int Y;
```

```

// Add 1 to the (X, Y) position.
public void Increment()
{
    X++; Y++;
}

// Subtract 1 from the (X, Y) position.
public void Decrement()
{
    X--; Y--;
}

// Display the current position.
public void Display()
{
    Console.WriteLine("X = {0}, Y = {1}", X, Y);
}
}

```

Here, you have defined your two integer fields (X and Y) using the `public` keyword, which is an access control modifier (Chapter 5 furthers this discussion). Declaring data with the `public` keyword ensures the caller has direct access to the data from a given `Point` variable (via the dot operator).

■ **Note** It is typically considered bad style to define public data within a class or structure. Rather, you will want to define *private* data, which can be accessed and changed using *public* properties. These details will be examined in Chapter 5.

Here is a `Main()` method that takes the `Point` type out for a test-drive:

```

static void Main(string[] args)
{
    Console.WriteLine("***** A First Look at Structures *****\n");

    // Create an initial Point.
    Point myPoint;
    myPoint.X = 349;
    myPoint.Y = 76;
    myPoint.Display();

    // Adjust the X and Y values.
    myPoint.Increment();
    myPoint.Display();
    Console.ReadLine();
}

```

The output is as you would expect.

```
***** A First Look at Structures *****
```

```
X = 349, Y = 76
X = 350, Y = 77
```

Creating Structure Variables

When you want to create a structure variable, you have a variety of options. Here, you simply create a `Point` variable and assign each piece of public field data before invoking its members. If you do *not* assign each piece of public field data (`X` and `Y` in this case) before using the structure, you will receive a compiler error.

```
// Error! Did not assign Y value.
Point p1;
p1.X = 10;
p1.Display();

// OK! Both fields assigned before use.
Point p2;
p2.X = 10;
p2.Y = 10;
p2.Display();
```

As an alternative, you can create structure variables using the C# `new` keyword, which will invoke the structure's *default constructor*. By definition, a default constructor does not take any arguments. The benefit of invoking the default constructor of a structure is that each piece of field data is automatically set to its default value.

```
// Set all fields to default values
// using the default constructor.
Point p1 = new Point();

// Prints X=0,Y=0.
p1.Display();
```

It is also possible to design a structure with a *custom constructor*. This allows you to specify the values of field data upon variable creation, rather than having to set each data member field by field. Chapter 5 will provide a detailed examination of constructors; however, to illustrate, update the `Point` structure with the following code:

```
struct Point
{
    // Fields of the structure.
    public int X;
    public int Y;
```

```
// A custom constructor.
public Point(int XPos, int YPos)
{
    X = XPos;
    Y = YPos;
}
...
}
```

With this, you could now create `Point` variables, as follows:

```
// Call custom constructor.
Point p2 = new Point(50, 60);

// Prints X=50,Y=60.
p2.Display();
```

As mentioned, working with structures on the surface is quite simple. However, to deepen your understanding of this type, you need to explore the distinction between a .NET value type and a .NET reference type.

■ **Source Code** The `FunWithStructures` project is located in the [Chapter 4](#) subdirectory.

Understanding Value Types and Reference Types

■ **Note** The following discussion of value types and reference types assumes that you have a background in object-oriented programming. If this is not the case, you might want to skip to the “Understanding C# Nullable Types” section of this chapter and return to this section after you have read [Chapters 5 and 6](#).

Unlike arrays, strings, or enumerations, C# structures do not have an identically named representation in the .NET library (that is, there is no `System.Structure` class) but are implicitly derived from `System.ValueType`. Simply put, the role of `System.ValueType` is to ensure that the derived type (e.g., any structure) is allocated on the *stack*, rather than the garbage-collected *heap*. Simply put, data allocated on the stack can be created and destroyed quickly, as its lifetime is determined by the defining scope. Heap-allocated data, on the other hand, is monitored by the .NET garbage collector and has a lifetime that is determined by a large number of factors, which will be examined in [Chapter 13](#).

Functionally, the only purpose of `System.ValueType` is to override the virtual methods defined by `System.Object` to use value-based, versus reference-based, semantics. As you might know, overriding is the process of changing the implementation of a virtual (or possibly abstract) method defined within a base class. The base class of `ValueType` is `System.Object`. In fact, the instance methods defined by `System.ValueType` are identical to those of `System.Object`.

```
// Structures and enumerations implicitly extend System.ValueType.
public abstract class ValueType : object
{
    public virtual bool Equals(object obj);
    public virtual int GetHashCode();
    public Type GetType();
    public virtual string ToString();
}
```

Given that value types are using value-based semantics, the lifetime of a structure (which includes all numerical data types [int, float], as well as any enum or structure) is predictable. When a structure variable falls out of the defining scope, it is removed from memory immediately.

```
// Local structures are popped off
// the stack when a method returns.
static void LocalValueTypes()
{
    // Recall! "int" is really a System.Int32 structure.
    int i = 0;

    // Recall! Point is a structure type.
    Point p = new Point();
} // "i" and "p" popped off the stack here!
```

Value Types, Reference Types, and the Assignment Operator

When you assign one value type to another, a member-by-member copy of the field data is achieved. In the case of a simple data type such as `System.Int32`, the only member to copy is the numerical value. However, in the case of your `Point`, the `X` and `Y` values are copied into the new structure variable. To illustrate, create a new Console Application project named `ValueAndReferenceTypes` and then copy your previous `Point` definition into your new namespace. Next, add the following method to your `Program` type:

```
// Assigning two intrinsic value types results in
// two independent variables on the stack.
static void ValueTypeAssignment()
{
    Console.WriteLine("Assigning value types\n");

    Point p1 = new Point(10, 10);
    Point p2 = p1;

    // Print both points.
    p1.Display();
    p2.Display();

    // Change p1.X and print again. p2.X is not changed.
    p1.X = 100;
    Console.WriteLine("\n=> Changed p1.X\n");
    p1.Display();
    p2.Display();
}
```

Here, you have created a variable of type `Point` (named `p1`) that is then assigned to another `Point` (`p2`). Because `Point` is a value type, you have two copies of the `MyPoint` type on the stack, each of which can be independently manipulated. Therefore, when you change the value of `p1.X`, the value of `p2.X` is unaffected.

Assigning value types

```
X = 10, Y = 10
X = 10, Y = 10
=> Changed p1.X
X = 100, Y = 10
X = 10, Y = 10
```

In stark contrast to value types, when you apply the assignment operator to reference types (meaning all class instances), you are redirecting what the reference variable points to in memory. To illustrate, create a new class type named `PointRef` that has the same members as the `Point` structures, beyond renaming the constructor to match the class name.

```
// Classes are always reference types.
class PointRef
{
    // Same members as the Point structure...
    // Be sure to change your constructor name to PointRef!
    public PointRef(int XPos, int YPos)
    {
        X = XPos;
        Y = YPos;
    }
}
```

Now, use your `PointRef` type within the following new method. Note that beyond using the `PointRef` class, rather than the `Point` structure, the code is identical to the `ValueTypeAssignment()` method.

```
static void ReferenceTypeAssignment()
{
    Console.WriteLine("Assigning reference types\n");
    PointRef p1 = new PointRef(10, 10);
    PointRef p2 = p1;

    // Print both point refs.
    p1.Display();
    p2.Display();

    // Change p1.X and print again.
    p1.X = 100;
    Console.WriteLine("\n=> Changed p1.X\n");
    p1.Display();
    p2.Display();
}
```

In this case, you have two references pointing to the same object on the managed heap. Therefore, when you change the value of `X` using the `p1` reference, `p2.X` reports the same value. Assuming you have called this new method within `Main()`, your output should look like the following:

```
Assigning reference types
X = 10, Y = 10
X = 10, Y = 10
=> Changed p1.X
X = 100, Y = 10
X = 100, Y = 10
```

Value Types Containing Reference Types

Now that you have a better feeling for the basic differences between value types and reference types, let's examine a more complex example. Assume you have the following reference (class) type that maintains an informational string that can be set using a custom constructor:

```
class ShapeInfo
{
    public string infoString;
    public ShapeInfo(string info)
    {
        infoString = info;
    }
}
```

Now assume that you want to contain a variable of this class type within a value type named `Rectangle`. To allow the caller to set the value of the inner `ShapeInfo` member variable, you also provide a custom constructor. Here is the complete definition of the `Rectangle` type:

```
struct Rectangle
{
    // The Rectangle structure contains a reference type member.
    public ShapeInfo rectInfo;

    public int rectTop, rectLeft, rectBottom, rectRight;

    public Rectangle(string info, int top, int left, int bottom, int right)
    {
        rectInfo = new ShapeInfo(info);
        rectTop = top; rectBottom = bottom;
        rectLeft = left; rectRight = right;
    }

    public void Display()
    {
        Console.WriteLine("String = {0}, Top = {1}, Bottom = {2}, " +
            "Left = {3}, Right = {4}",
            rectInfo.infoString, rectTop, rectBottom, rectLeft, rectRight);
    }
}
```

At this point, you have contained a reference type within a value type. The million-dollar question now becomes, what happens if you assign one `Rectangle` variable to another? Given what you already know about value types, you would be correct in assuming that the integer data (which is indeed a structure—`System.Int32`) should be an independent entity for each `Rectangle` variable. But what about the internal reference type? Will the object's *state* be fully copied, or will the reference to that object be copied? To answer this question, define the following method and invoke it from `Main()`:

```
static void ValueTypeContainingRefType()
{
    // Create the first Rectangle.
    Console.WriteLine("-> Creating r1");
    Rectangle r1 = new Rectangle("First Rect", 10, 10, 50, 50);

    // Now assign a new Rectangle to r1.
    Console.WriteLine("-> Assigning r2 to r1");
    Rectangle r2 = r1;

    // Change some values of r2.
    Console.WriteLine("-> Changing values of r2");
    r2.rectInfo.infoString = "This is new info!";
    r2.rectBottom = 4444;

    // Print values of both rectangles.
    r1.Display();
    r2.Display();
}
```

The output can be seen in the following:

```
-> Creating r1
-> Assigning r2 to r1
-> Changing values of r2
String = This is new info!, Top = 10, Bottom = 50, Left = 10, Right = 50
String = This is new info!, Top = 10, Bottom = 4444, Left = 10, Right = 50
```

As you can see, when you change the value of the informational string using the `r2` reference, the `r1` reference displays the same value. By default, when a value type contains other reference types, assignment results in a copy of the references. In this way, you have two independent structures, each of which contains a reference pointing to the same object in memory (i.e., a shallow copy). When you want to perform a deep copy, where the state of internal references is fully copied into a new object, one approach is to implement the `ICloneable` interface (as you will do in Chapter 8).

■ **Source Code** The `ValueAndReferenceTypes` project is located in the Chapter 4 subdirectory.

Passing Reference Types by Value

Reference types or value types can, obviously, be passed as parameters to methods. However, passing a reference type (e.g., a class) by reference is quite different from passing it by value. To understand the distinction, assume you have a simple `Person` class defined in a new Console Application project named `RefTypeValTypeParams`, defined as follows:

```
class Person
{
    public string personName;
    public int personAge;

    // Constructors.
    public Person(string name, int age)
    {
        personName = name;
        personAge = age;
    }
    public Person(){}

    public void Display()
    {
        Console.WriteLine("Name: {0}, Age: {1}", personName, personAge);
    }
}
```

Now, what if you create a method that allows the caller to send in the `Person` object by value (note the lack of parameter modifiers, such as `out` or `ref`)?

```
static void SendAPersonByValue(Person p)
{
    // Change the age of "p"?
    p.personAge = 99;

    // Will the caller see this reassignment?
    p = new Person("Nikki", 99);
}
```

Notice how the `SendAPersonByValue()` method attempts to reassign the incoming `Person` reference to a new `Person` object, as well as change some state data. Now let's test this method using the following `Main()` method:

```
static void Main(string[] args)
{
    // Passing ref-types by value.
    Console.WriteLine("***** Passing Person object by value *****");
    Person fred = new Person("Fred", 12);
    Console.WriteLine("\nBefore by value call, Person is:");
    fred.Display();
}
```

```

SendAPersonByValue(fred);
Console.WriteLine("\nAfter by value call, Person is:");
fred.Display();
Console.ReadLine();
}

```

The following is the output of this call:

```

***** Passing Person object by value *****

```

```

Before by value call, Person is:
Name: Fred, Age: 12

```

```

After by value call, Person is:
Name: Fred, Age: 99

```

As you can see, the value of `personAge` has been modified. This behavior seems to fly in the face of what it means to pass a parameter “by value.” Given that you were able to change the state of the incoming `Person`, what was copied? The answer: a copy of the reference to the caller’s object. Therefore, as the `SendAPersonByValue()` method is pointing to the same object as the caller, it is possible to alter the object’s state data. What is not possible is to reassign what the reference *is pointing to*.

Passing Reference Types by Reference

Now assume you have a `SendAPersonByReference()` method, which passes a reference type by reference (note the `ref` parameter modifier).

```

static void SendAPersonByReference(ref Person p)
{
    // Change some data of "p".
    p.personAge = 555;

    // "p" is now pointing to a new object on the heap!
    p = new Person("Nikki", 999);
}

```

As you might expect, this allows complete flexibility of how the callee is able to manipulate the incoming parameter. Not only can the callee change the state of the object, but if it so chooses, it may also reassign the reference to a new `Person` object. Now ponder the following updated `Main()` method:

```

static void Main(string[] args)
{
    // Passing ref-types by ref.
    Console.WriteLine("***** Passing Person object by reference *****");
    ...

    Person mel = new Person("Mel", 23);
    Console.WriteLine("Before by ref call, Person is:");
    mel.Display();
}

```

```

SendAPersonByReference(ref mel);
Console.WriteLine("After by ref call, Person is:");
mel.Display();
Console.ReadLine();
}

```

Notice the following output:

```

***** Passing Person object by reference *****
Before by ref call, Person is:
Name: Mel, Age: 23
After by ref call, Person is:
Name: Nikki, Age: 999

```

As you can see, an object named `Mel` returns after the call as an object named `Nikki`, as the method was able to change what the incoming reference pointed to in memory. The golden rule to keep in mind when passing reference types is the following:

- If a reference type is passed by reference, the callee may change the values of the object's state data, as well as the object it is referencing.
- If a reference type is passed by value, the callee may change the values of the object's state data but *not* the object it is referencing.

■ **Source Code** The `RefTypeValTypeParams` project is located in the Chapter 4 subdirectory.

Final Details Regarding Value Types and Reference Types

To wrap up this topic, consider the information in Table 4-3, which summarizes the core distinctions between value types and reference types.

Table 4-3. *Value Types and Reference Types Comparison*

| Intriguing Question | Value Type | Reference Type |
|--|---|---|
| Where are objects allocated? | Allocated on the stack. | Allocated on the managed heap. |
| How is a variable represented? | Value type variables are local copies. | Reference type variables are pointing to the memory occupied by the allocated instance. |
| What is the base type? | Implicitly extends <code>System.ValueType</code> . | Can derive from any other type (except <code>System.ValueType</code>), as long as that type is not “sealed” (more details on this in Chapter 6). |
| Can this type function as a base to other types? | No. Value types are always sealed and cannot be inherited from. | Yes. If the type is not sealed, it may function as a base to other types. |

(continued)

Table 4-3. (continued)

| Intriguing Question | Value Type | Reference Type |
|--|--|--|
| What is the default parameter passing behavior? | Variables are passed by value (i.e., a copy of the variable is passed into the called function). | For reference types, the reference is copied by value. |
| Can this type override <code>System.Object.Finalize()</code> ? | No. | Yes, indirectly (more details on this in Chapter 13). |
| Can I define constructors for this type? | Yes, but the default constructor is reserved (i.e., your custom constructors must all have arguments). | But, of course! |
| When do variables of this type die? | When they fall out of the defining scope. | When the object is garbage collected. |

Despite their differences, value types and reference types both have the ability to implement interfaces and may support any number of fields, methods, overloaded operators, constants, properties, and events.

Understanding C# Nullable Types

To wrap up this chapter, let's examine the role of *nullable data type* using a final Console Application project named `NullableTypes`. As you know, C# data types have a fixed range and are represented as a type in the `System` namespace. For example, the `System.Boolean` data type can be assigned a value from the set `{true, false}`. Now, recall that all the numerical data types (as well as the `Boolean` data type) are *value types*. Value types can never be assigned the value of `null`, as that is used to establish an empty object reference.

```
static void Main(string[] args)
{
    // Compiler errors!
    // Value types cannot be set to null!
    bool myBool = null;
    int myInt = null;

    // OK! Strings are reference types.
    string myString = null;
}
```

C# supports the concept of *nullable data types*. Simply put, a nullable type can represent all the values of its underlying type, plus the value `null`. Thus, if you declare a nullable `bool`, it could be assigned a value from the set `{true, false, null}`. This can be extremely helpful when working with relational databases, given that it is quite common to encounter undefined columns in database tables. Without the concept of a nullable data type, there is no convenient manner in C# to represent a numerical data point with no value.

To define a nullable variable type, the question mark symbol (?) is suffixed to the underlying data type. Do note that this syntax is legal only when applied to value types. If you attempt to create a nullable reference type (including strings), you are issued a compile-time error. Like a non-nullable variable, local nullable variables must be assigned an initial value before you can use them.

```

static void LocalNullableVariables()
{
    // Define some local nullable variables.
    int? nullableInt = 10;
    double? nullableDouble = 3.14;
    bool? nullableBool = null;
    char? nullableChar = 'a';
    int?[] arrayOfNullableInts = new int?[10];

    // Error! Strings are reference types!
    // string? s = "oops";
}

```

In C#, the ? suffix notation is a shorthand for creating an instance of the generic `System.Nullable<T>` structure type. Although you will not examine generics until Chapter 9, it is important to understand that the `System.Nullable<T>` type provides a set of members that all nullable types can make use of.

For example, you are able to programmatically discover whether the nullable variable indeed has been assigned a null value using the `HasValue` property or the `!=` operator. The assigned value of a nullable type may be obtained directly or via the `Value` property. In fact, given that the ? suffix is just a shorthand for using `Nullable<T>`, you could implement your `LocalNullableVariables()` method as follows:

```

static void LocalNullableVariablesUsingNullable()
{
    // Define some local nullable types using Nullable<T>.
    Nullable<int> nullableInt = 10;
    Nullable<double> nullableDouble = 3.14;
    Nullable<bool> nullableBool = null;
    Nullable<char> nullableChar = 'a';
    Nullable<int>[] arrayOfNullableInts = new Nullable<int>[10];
}

```

Working with Nullable Types

As stated, nullable data types can be particularly useful when you are interacting with databases, given that columns in a data table may be intentionally empty (e.g., undefined). To illustrate, assume the following class, which simulates the process of accessing a database that has a table containing two columns that may be null. Note that the `GetIntFromDatabase()` method is not assigning a value to the nullable integer member variable, while `GetBoolFromDatabase()` is assigning a valid value to the `bool?` member.

```

class DatabaseReader
{
    // Nullable data field.
    public int? numericValue = null;
    public bool? boolValue = true;

    // Note the nullable return type.
    public int? GetIntFromDatabase()
    { return numericValue; }
}

```

```

// Note the nullable return type.
public bool? GetBoolFromDatabase()
{ return boolValue; }
}

```

Now, assume the following `Main()` method, which invokes each member of the `DatabaseReader` class and discovers the assigned values using the `HasValue` and `Value` members, as well as using the C# equality operator (not equal, to be exact):

```

static void Main(string[] args)
{
    Console.WriteLine("***** Fun with Nullable Data *****\n");
    DatabaseReader dr = new DatabaseReader();

    // Get int from "database".
    int? i = dr.GetIntFromDatabase();
    if (i.HasValue)
        Console.WriteLine("Value of 'i' is: {0}", i.Value);
    else
        Console.WriteLine("Value of 'i' is undefined.");
    // Get bool from "database".
    bool? b = dr.GetBoolFromDatabase();
    if (b != null)
        Console.WriteLine("Value of 'b' is: {0}", b.Value);
    else
        Console.WriteLine("Value of 'b' is undefined.");
    Console.ReadLine();
}

```

The Null Coalescing Operator

The next aspect to be aware of is any variable that might have a null value (i.e., a reference-type variable or a nullable value-type variable) can make use of the C# `??` operator, which is formally termed the *null coalescing operator*. This operator allows you to assign a value to a nullable type if the retrieved value is in fact null. For this example, assume you want to assign a local nullable integer to 100 if the value returned from `GetIntFromDatabase()` is null (of course, this method is programmed to always return null, but I am sure you get the general idea).

```

static void Main(string[] args)
{
    Console.WriteLine("***** Fun with Nullable Data *****\n");
    DatabaseReader dr = new DatabaseReader();
    ...
    // If the value from GetIntFromDatabase() is null,
    // assign local variable to 100.
    int myData = dr.GetIntFromDatabase() ?? 100;
    Console.WriteLine("Value of myData: {0}", myData);
    Console.ReadLine();
}

```

The benefit of using the ?? operator is that it provides a more compact version of a traditional if/else condition. However, if you want, you could have authored the following functionally equivalent code to ensure that if a value comes back as null, it will indeed be set to the value 100:

```
// Long-hand notation not using ?? syntax.
int? moreData = dr.GetIntFromDatabase();
if (!moreData.HasValue)
    moreData = 100;
Console.WriteLine("Value of moreData: {0}", moreData);
```

The Null Conditional Operator

When you are writing software, it is common to check incoming parameters, values returned from type members (methods, properties, indexers) against the value null. For example, let's assume you have a method that takes a string array as a single parameter. To be safe, you might want to test for null before proceeding. In that way, you will not get a runtime error if the array is empty. The following would be a traditional way to perform such a check:

```
static void TesterMethod(string[] args)
{
    // We should check for null before accessing the array data!
    if (args != null)
    {
        Console.WriteLine($"You sent me {args.Length} arguments.");
    }
}
```

Here, you use a conditional scope to ensure that the Length property of the string array will not be accessed if the array is null. If the caller failed to make an array of data and called your method like so, you are still safe and will not trigger a runtime error:

```
TesterMethod(null);
```

With the current release of the C# language, it is now possible to leverage the null conditional operator token (a question mark placed after a variable type but before an access operator) to simplify the previous error checking. Rather than explicitly building a conditional statement to check for null, you can now write the following:

```
static void TesterMethod(string[] args)
{
    // We should check for null before accessing the array data!
    Console.WriteLine($"You sent me {args?.Length} arguments.");
}
```

In this case, you are not using a conditional statement. Rather, you are suffixing the ? operator directly after the string array variable. If this is null, its call to the Length property will not throw a runtime error. If you want to print an actual value, you could leverage the null coalescing operator to assign a default value as so:

```
Console.WriteLine($"You sent me {args?.Length ?? 0} arguments.");
```

There are some additional areas of coding where the new C# 6.0 `null` conditional operator will be quite handy, especially when working with delegates and events. However, since those topics are not addressed until later in the book (see Chapter 10), you will hold on any additional use cases. With this, your initial investigation of the C# programming language is complete! In Chapter 5, you will begin to dig into the details of object-oriented development.

■ **Source Code** The `NullableTypes` application is located in the Chapter 4 subdirectory.

Summary

This chapter began with an examination of several C# keywords that allow you to build custom methods. Recall that by default parameters are passed by value; however, you may pass a parameter by reference if you mark it with `ref` or `out`. You also learned about the role of optional or named parameters and how to define and invoke methods taking parameter arrays.

After you investigated the topic of method overloading, the bulk of this chapter examined several details regarding how arrays, enumerations, and structures are defined in C# and represented within the .NET base class libraries. Along the way, you examined several details regarding value types and reference types, including how they respond when passing them as parameters to methods and how to interact with nullable data types and variables that might be `null` (e.g., reference-type variables and nullable value-type variables) using the `?` and `??` operators.

PART III



Object-Oriented Programming with C#

CHAPTER 5



Understanding Encapsulation

In the Chapters 3 and 4, you investigated a number of core syntactical constructs that are commonplace to any .NET application you might be developing. Here, you will begin your examination of the object-oriented capabilities of C#. The first order of business is to examine the process of building well-defined class types that support any number of *constructors*. After you understand the basics of defining classes and allocating objects, the remainder of this chapter will examine the role of *encapsulation*. Along the way, you will learn how to define class properties and come to understand the details of the *static* keyword, object initialization syntax, read-only fields, constant data, and partial classes.

Introducing the C# Class Type

As far as the .NET platform is concerned, the most fundamental programming construct is the *class type*. Formally, a class is a user-defined type that is composed of field data (often called *member variables*) and members that operate on this data (such as constructors, properties, methods, events, and so forth). Collectively, the set of field data represents the “state” of a class instance (otherwise known as an *object*). The power of object-oriented languages, such as C#, is that by grouping data and related functionality in a unified class definition, you are able to model your software after entities in the real world.

To get the ball rolling, create a new C# Console Application project named SimpleClassExample. Next, insert a new class file (named Car.cs) into your project using the Project ► Add Class menu selection. Choose the Class icon from the resulting dialog box, as shown in Figure 5-1, and click the Add button.

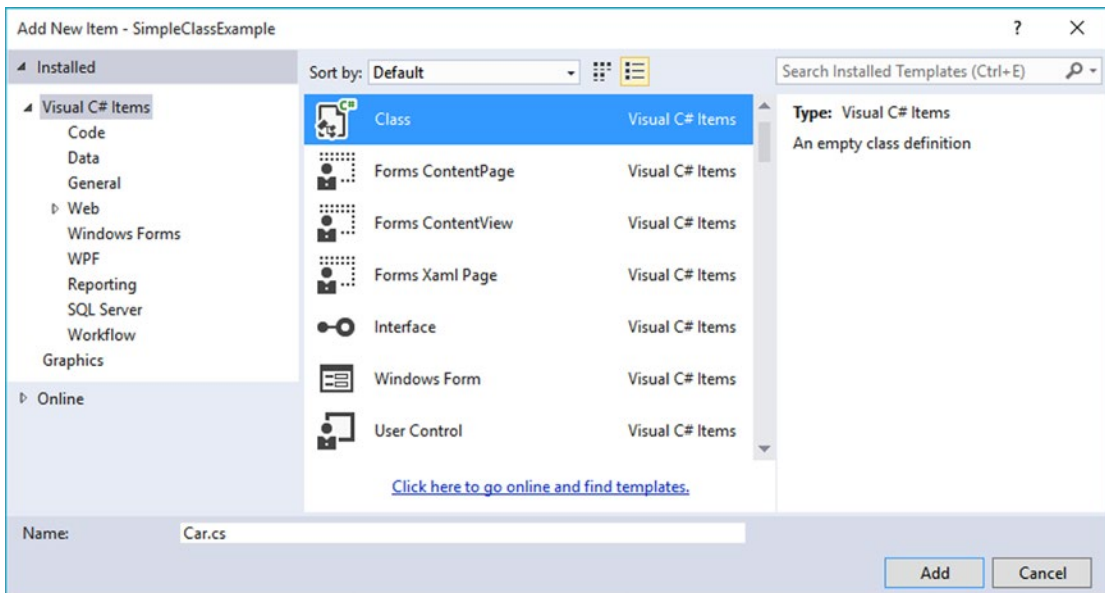

Figure 5-1. Inserting a new C# class type

A class is defined in C# using the `class` keyword. Here is the simplest possible declaration:

```
class Car
{
}
```

After you have defined a class type, you will need to consider the set of member variables that will be used to represent its state. For example, you might decide that cars maintain an `int` data type to represent the current speed and a `string` data type to represent the car's friendly pet name. Given these initial design notes, update your `Car` class as follows:

```
class Car
{
    // The 'state' of the Car.
    public string petName;
    public int currSpeed;
}
```

Notice that these member variables are declared using the `public` access modifier. Public members of a class are directly accessible once an object of this type has been created. Recall the term *object* is used to describe an instance of a given class type created using the `new` keyword.

■ **Note** Field data of a class should seldom (if ever) be defined as `public`. To preserve the integrity of your state data, it is a far better design to define data as `private` (or possibly `protected`) and allow controlled access to the data via properties (as shown later in this chapter). However, to keep this first example as simple as possible, public data fits the bill.

After you have defined the set of member variables that represent the state of the class, the next design step is to establish the members that model its behavior. For this example, the Car class will define one method named `SpeedUp()` and another named `PrintState()`. Update your class as so:

```
class Car
{
    // The 'state' of the Car.
    public string petName;
    public int currSpeed;

    // The functionality of the Car.
    public void PrintState()
    {
        Console.WriteLine("{0} is going {1} MPH.", petName, currSpeed);
    }

    public void SpeedUp(int delta)
    {
        currSpeed += delta;
    }
}
```

`PrintState()` is more or less a diagnostic function that will simply dump the current state of a given Car object to the command window. `SpeedUp()` will increase the speed of the Car by the amount specified by the incoming int parameter. Now, update your `Main()` method in the Program class with the following code:

```
static void Main(string[] args)
{
    Console.WriteLine("***** Fun with Class Types *****\n");

    // Allocate and configure a Car object.
    Car myCar = new Car();
    myCar.petName = "Henry";
    myCar.currSpeed = 10;

    // Speed up the car a few times and print out the
    // new state.
    for (int i = 0; i <= 10; i++)
    {
        myCar.SpeedUp(5);
        myCar.PrintState();
    }
    Console.ReadLine();
}
```

After you run your program, you will see that the `Car` variable (`myCar`) maintains its current state throughout the life of the application, as shown in the following code:

```
***** Fun with Class Types *****
```

```
Henry is going 15 MPH.
Henry is going 20 MPH.
Henry is going 25 MPH.
Henry is going 30 MPH.
Henry is going 35 MPH.
Henry is going 40 MPH.
Henry is going 45 MPH.
Henry is going 50 MPH.
Henry is going 55 MPH.
Henry is going 60 MPH.
Henry is going 65 MPH.
```

Allocating Objects with the new Keyword

As shown in the previous code example, objects must be allocated into memory using the `new` keyword. If you do not use the `new` keyword and attempt to use your class variable in a subsequent code statement, you will receive a compiler error. For example, the following `Main()` method will not compile:

```
static void Main(string[] args)
{
    Console.WriteLine("***** Fun with Class Types *****\n");

    // Compiler error! Forgot to use 'new' to create object!
    Car myCar;
    myCar.petName = "Fred";
}
```

To correctly create an object using the `new` keyword, you may define and allocate a `Car` object on a single line of code.

```
static void Main(string[] args)
{
    Console.WriteLine("***** Fun with Class Types *****\n");
    Car myCar = new Car();
    myCar.petName = "Fred";
}
```

As an alternative, if you want to define and allocate a class instance on separate lines of code, you may do so as follows:

```
static void Main(string[] args)
{
    Console.WriteLine("***** Fun with Class Types *****\n");
    Car myCar;
    myCar = new Car();
    myCar.petName = "Fred";
}
```

Here, the first code statement simply declares a reference to a yet-to-be-determined `Car` object. It is not until you assign a reference to an object that this reference points to a valid object in memory.

In any case, at this point you have a trivial class that defines a few points of data and some basic operations. To enhance the functionality of the current `Car` class, you need to understand the role of *constructors*.

Understanding Constructors

Given that objects have state (represented by the values of an object’s member variables), a programmer will typically want to assign relevant values to the object’s field data before use. Currently, the `Car` class demands that the `petName` and `currSpeed` fields be assigned on a field-by-field basis. For the current example, this is not too problematic, given that you have only two public data points. However, it is not uncommon for a class to have dozens of fields to contend with. Clearly, it would be undesirable to author 20 initialization statements to set 20 points of data!

Thankfully, `C#` supports the use of *constructors*, which allow the state of an object to be established at the time of creation. A constructor is a special method of a class that is called indirectly when creating an object using the `new` keyword. However, unlike a “normal” method, constructors never have a return value (not even `void`) and are always named identically to the class they are constructing.

The Role of the Default Constructor

Every `C#` class is provided with a “freebie” *default constructor* that you can redefine if need be. By definition, a default constructor never takes arguments. After allocating the new object into memory, the default constructor ensures that all field data of the class is set to an appropriate default value (see Chapter 3 for information regarding the default values of `C#` data types).

If you are not satisfied with these default assignments, you may redefine the default constructor to suit your needs. To illustrate, update your C# Car class as follows:

```
class Car
{
    // The 'state' of the Car.
    public string petName;
    public int currSpeed;

    // A custom default constructor.
    public Car()
    {
        petName = "Chuck";
        currSpeed = 10;
    }
    ...
}
```

In this case, you are forcing all Car objects to begin life named Chuck at a rate of 10 mph. With this, you are able to create a Car object set to these default values as follows:

```
static void Main(string[] args)
{
    Console.WriteLine("***** Fun with Class Types *****\n");

    // Invoking the default constructor.
    Car chuck = new Car();

    // Prints "Chuck is going 10 MPH."
    chuck.PrintState();
    ...
}
```

Defining Custom Constructors

Typically, classes define additional constructors beyond the default. In doing so, you provide the object user with a simple and consistent way to initialize the state of an object directly at the time of creation. Ponder the following update to the Car class, which now supports a total of three constructors:

```
class Car
{
    // The 'state' of the Car.
    public string petName;
    public int currSpeed;

    // A custom default constructor.
    public Car()
    {
        petName = "Chuck";
        currSpeed = 10;
    }
}
```

```

// Here, currSpeed will receive the
// default value of an int (zero).
public Car(string pn)
{
    petName = pn;
}

// Let caller set the full state of the Car.
public Car(string pn, int cs)
{
    petName = pn;
    currSpeed = cs;
}
...
}

```

Keep in mind that what makes one constructor different from another (in the eyes of the C# compiler) is the number of and/or type of constructor arguments. Recall from Chapter 4, when you define a method of the same name that differs by the number or type of arguments, you have *overloaded* the method. Thus, the Car class has overloaded the constructor to provide a number of ways to create an object at the time of declaration. In any case, you are now able to create Car objects using any of the public constructors. Here's an example:

```

static void Main(string[] args)
{
    Console.WriteLine("***** Fun with Class Types *****\n");

    // Make a Car called Chuck going 10 MPH.
    Car chuck = new Car();
    chuck.PrintState();

    // Make a Car called Mary going 0 MPH.
    Car mary = new Car("Mary");
    mary.PrintState();

    // Make a Car called Daisy going 75 MPH.
    Car daisy = new Car("Daisy", 75);
    daisy.PrintState();

    ...
}Encapsulation:constructors:

```

The Default Constructor Revisited

As you have just learned, all classes are provided with a free default constructor. Thus, if you insert a new class into your current project named Motorcycle, defined like so:

```

class Motorcycle
{
    public void PopAWheely()
    {
        Console.WriteLine("YeEEEEEE Haaaaaeewww!");
    }
}

```

you are able to create an instance of the `Motorcycle` type via the default constructor out of the box.

```
static void Main(string[] args)
{
    Console.WriteLine("***** Fun with Class Types *****\n");
    Motorcycle mc = new Motorcycle();
    mc.PopAWheely();
    ...
}
```

However, as soon as you define a custom constructor with any number of parameters, the default constructor is silently removed from the class and is no longer available. Think of it this way: if you do not define a custom constructor, the C# compiler grants you a default in order to allow the object user to allocate an instance of your type with field data set to the correct default values. However, when you define a unique constructor, the compiler assumes you have taken matters into your own hands.

Therefore, if you want to allow the object user to create an instance of your type with the default constructor, as well as your custom constructor, you must *explicitly* redefine the default. To this end, understand that in a vast majority of cases, the implementation of the default constructor of a class is intentionally empty, as all you require is the ability to create an object with default values. Consider the following update to the `Motorcycle` class:

```
class Motorcycle
{
    public int driverIntensity;

    public void PopAWheely()
    {
        for (int i = 0; i <= driverIntensity; i++)
        {
            Console.WriteLine("Yeaaaaa Haaaaaeeww!");
        }
    }

    // Put back the default constructor, which will
    // set all data members to default vaules.
    public Motorcycle() {}

    // Our custom constructor.
    public Motorcycle(int intensity)
    {
        driverIntensity = intensity;
    }
}
```

■ **Note** Now that you better understand the role of class constructors, here is a nice shortcut. The Visual Studio IDE provides the `ctor` code snippet. When you type `ctor` and press the Tab key twice, the IDE will automatically define a custom default constructor. You can then add custom parameters and implementation logic. Give it a try.

The Role of the `this` Keyword

C# supplies a `this` keyword that provides access to the current class instance. One possible use of the `this` keyword is to resolve scope ambiguity, which can arise when an incoming parameter is named identically to a data field of the class. Of course, you could simply adopt a naming convention that does not result in such ambiguity; however, to illustrate this use of the `this` keyword, update your `Motorcycle` class with a new string field (named `name`) to represent the driver's name. Next, add a method named `SetDriverName()` implemented as follows:

```
class Motorcycle
{
    public int driverIntensity;

    // New members to represent the name of the driver.
    public string name;
    public void SetDriverName(string name)
    {
        name = name;
    }
    ...
}
```

Although this code will compile just fine, Visual Studio will display a warning message informing you that you have assigned a variable back to itself! To illustrate, update `Main()` to call `SetDriverName()` and then print out the value of the `name` field. You might be surprised to find that the value of the `name` field is an empty string!

```
// Make a Motorcycle with a rider named Tiny?
Motorcycle c = new Motorcycle(5);
c.SetDriverName("Tiny");
c.PopAWheely();
Console.WriteLine("Rider name is {0}", c.name); // Prints an empty name value!
```

The problem is that the implementation of `SetDriverName()` is assigning the incoming parameter *back to itself* given that the compiler assumes `name` is referring to the variable currently in the method scope rather than the `name` field at the class scope. To inform the compiler that you want to set the current object's name data field to the incoming `name` parameter, simply use `this` to resolve the ambiguity.

```
public void SetDriverName(string name)
{
    this.name = name;
}
```

Do understand that if there is no ambiguity, you are not required to make use of the `this` keyword when a class wants to access its own data fields or members, as `this` is implied. For example, if you rename the string data member from `name` to `driverName` (which will also require you to update your `Main()` method), the use of `this` is optional as there is no longer a scope ambiguity.

```
class Motorcycle
{
    public int driverIntensity;
    public string driverName;

    public void SetDriverName(string name)
    {
        // These two statements are functionally the same.
        driverName = name;
        this.driverName = name;
    }
    ...
}
```

Even though there is little to be gained when using `this` in unambiguous situations, you might still find this keyword useful when implementing class members, as IDEs such as Visual Studio will enable IntelliSense when `this` is specified. This can be helpful when you have forgotten the name of a class member and want to quickly recall the definition. Consider Figure 5-2.

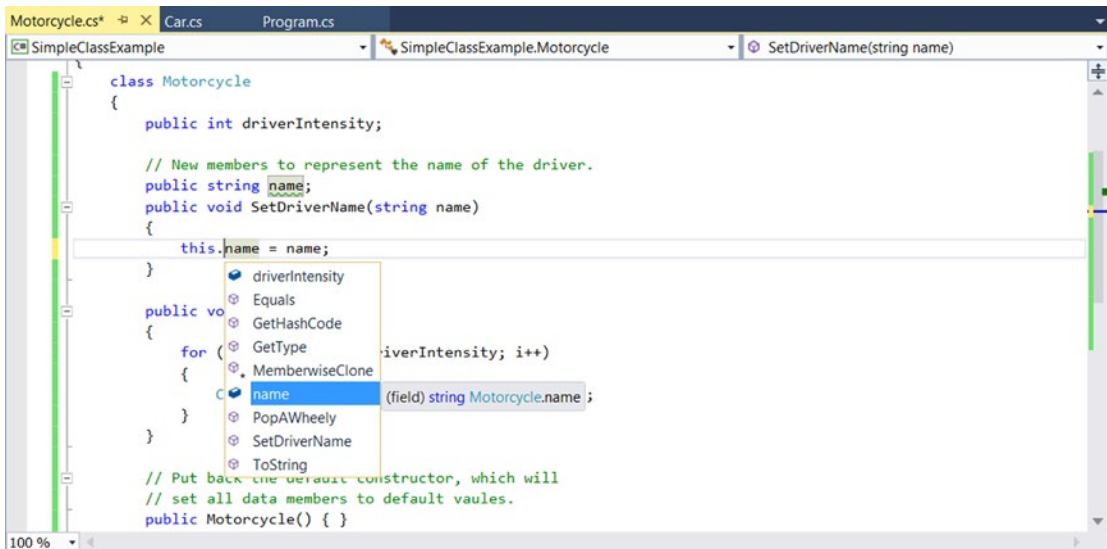

Figure 5-2. The IntelliSense of `this`

Chaining Constructor Calls Using `this`

Another use of the `this` keyword is to design a class using a technique termed *constructor chaining*. This design pattern is helpful when you have a class that defines multiple constructors. Given that constructors often validate the incoming arguments to enforce various business rules, it can be quite common to find redundant validation logic within a class's constructor set. Consider the following updated `Motorcycle`:

```
class Motorcycle
{
    public int driverIntensity;
    public string driverName;

    public Motorcycle() { }

    // Redundent constructor logic!
    public Motorcycle(int intensity)
    {
        if (intensity > 10)
        {
            intensity = 10;
        }
        driverIntensity = intensity;
    }

    public Motorcycle(int intensity, string name)
    {
        if (intensity > 10)
        {
            intensity = 10;
        }
        driverIntensity = intensity;
        driverName = name;
    }
    ...
}
```

Here (perhaps in an attempt to ensure the safety of the rider) each constructor is ensuring that the intensity level is never greater than 10. While this is all well and good, you do have redundant code statements in two constructors. This is less than ideal, as you are now required to update code in multiple locations if your rules change (for example, if the intensity should not be greater than 5 rather than 10).

One way to improve the current situation is to define a method in the `Motorcycle` class that will validate the incoming argument(s). If you were to do so, each constructor could make a call to this method before making the field assignment(s). While this approach does allow you to isolate the code you need to update when the business rules change, you are now dealing with the following redundancy:

```
class Motorcycle
{
    public int driverIntensity;
    public string driverName;

    // Constructors.
    public Motorcycle() { }

    public Motorcycle(int intensity)
    {
        SetIntensity(intensity);
    }

    public Motorcycle(int intensity, string name)
    {
        SetIntensity(intensity);
        driverName = name;
    }

    public void SetIntensity(int intensity)
    {
        if (intensity > 10)
        {
            intensity = 10;
        }
        driverIntensity = intensity;
    }
    ...
}
```

A cleaner approach is to designate the constructor that takes the *greatest number of arguments* as the “master constructor” and have its implementation perform the required validation logic. The remaining constructors can make use of the `this` keyword to forward the incoming arguments to the master constructor and provide any additional parameters as necessary. In this way, you need to worry only about maintaining a single constructor for the entire class, while the remaining constructors are basically empty.

Here is the final iteration of the `Motorcycle` class (with one additional constructor for the sake of illustration). When chaining constructors, note how the `this` keyword is “dangling” off the constructor’s declaration (via a colon operator) outside the scope of the constructor itself.

```

class Motorcycle
{
    public int driverIntensity;
    public string driverName;

    // Constructor chaining.
    public Motorcycle() {}
    public Motorcycle(int intensity)
        : this(intensity, "") {}
    public Motorcycle(string name)
        : this(0, name) {}

    // This is the 'master' constructor that does all the real work.
    public Motorcycle(int intensity, string name)
    {
        if (intensity > 10)
        {
            intensity = 10;
        }
        driverIntensity = intensity;
        driverName = name;
    }
    ...
}

```

Understand that using the `this` keyword to chain constructor calls is never mandatory. However, when you make use of this technique, you do tend to end up with a more maintainable and concise class definition. Again, using this technique, you can simplify your programming tasks, as the real work is delegated to a single constructor (typically the constructor that has the most parameters), while the other constructors simply “pass the buck.”

■ **Note** Recall from Chapter 4 that C# supports optional parameters. If you use optional parameters in your class constructors, you can achieve the same benefits as constructor chaining, with considerably less code. You will see how to do so in just a moment.

Observing Constructor Flow

On a final note, do know that once a constructor passes arguments to the designated master constructor (and that constructor has processed the data), the constructor invoked originally by the caller will finish executing any remaining code statements. To clarify, update each of the constructors of the `Motorcycle` class with a fitting call to `Console.WriteLine()`.

```

class Motorcycle
{
    public int driverIntensity;
    public string driverName;

    // Constructor chaining.
    public Motorcycle()
    {
        Console.WriteLine("In default ctor");
    }

    public Motorcycle(int intensity)
        : this(intensity, "")
    {
        Console.WriteLine("In ctor taking an int");
    }

    public Motorcycle(string name)
        : this(0, name)
    {
        Console.WriteLine("In ctor taking a string");
    }

    // This is the 'master' constructor that does all the real work.
    public Motorcycle(int intensity, string name)
    {
        Console.WriteLine("In master ctor ");
        if (intensity > 10)
        {
            intensity = 10;
        }
        driverIntensity = intensity;
        driverName = name;
    }
    ...
}

```

Now, ensure your `Main()` method exercises a `Motorcycle` object as follows:

```

static void Main(string[] args)
{
    Console.WriteLine("***** Fun with class Types *****\n");

    // Make a Motorcycle.
    Motorcycle c = new Motorcycle(5);
    c.SetDriverName("Tiny");
    c.PopAWheely();
    Console.WriteLine("Rider name is {0}", c.driverName);
    Console.ReadLine();
}

```

With this, ponder the output from the previous `Main()` method.

```
***** Fun with class Types *****
```

```
In master ctor
In ctor taking an int
Yeaaaaa Haaaaaeewww!
Yeaaaaa Haaaaaeewww!
Yeaaaaa Haaaaaeewww!
Yeaaaaa Haaaaaeewww!
Yeaaaaa Haaaaaeewww!
Yeaaaaa Haaaaaeewww!
Rider name is Tiny
```

As you can see, the flow of constructor logic is as follows:

- You create your object by invoking the constructor requiring a single `int`.
- This constructor forwards the supplied data to the master constructor and provides any additional startup arguments not specified by the caller.
- The master constructor assigns the incoming data to the object's field data.
- Control is returned to the constructor originally called and executes any remaining code statements.

The nice thing about using constructor chaining is that this programming pattern will work with any version of the C# language and .NET platform. However, if you are targeting .NET 4.0 and higher, you can further simplify your programming tasks by making use of optional arguments as an alternative to traditional constructor chaining.

Revisiting Optional Arguments

In Chapter 4, you learned about optional and named arguments. Recall that optional arguments allow you to define supplied default values to incoming arguments. If the caller is happy with these defaults, they are not required to specify a unique value; however, they may do so to provide the object with custom data. Consider the following version of `Motorcycle`, which now provides a number of ways to construct objects using a *single* constructor definition:

```
class Motorcycle
{
    // Single constructor using optional args.
    public Motorcycle(int intensity = 0, string name = "")
    {
        if (intensity > 10)
        {
            intensity = 10;
        }
        driverIntensity = intensity;
        driverName = name;
    }
    ...
}
```

With this one constructor, you are now able to create a new `Motorcycle` object using zero, one, or two arguments. Recall that named argument syntax allows you to essentially skip over acceptable default settings (see Chapter 3).

```
static void MakeSomeBikes()
{
    // driverName = "", driverIntensity = 0
    Motorcycle m1 = new Motorcycle();
    Console.WriteLine("Name= {0}, Intensity= {1}",
        m1.driverName, m1.driverIntensity);

    // driverName = "Tiny", driverIntensity = 0
    Motorcycle m2 = new Motorcycle(name:"Tiny");
    Console.WriteLine("Name= {0}, Intensity= {1}",
        m2.driverName, m2.driverIntensity);

    // driverName = "", driverIntensity = 7
    Motorcycle m3 = new Motorcycle(7);
    Console.WriteLine("Name= {0}, Intensity= {1}",
        m3.driverName, m3.driverIntensity);
}
```

In any case, at this point you are able to define a class with field data (aka member variables) and various operations such as methods and constructors. Next up, let's formalize the role of the `static` keyword.

■ **Source Code** The `SimpleClassExample` project is included in the Chapter 5 subdirectory.

Understanding the static Keyword

A C# class may define any number of *static members*, which are declared using the `static` keyword. When you do so, the member in question must be invoked directly from the class level, rather than from an object reference variable. To illustrate the distinction, consider your good friend `System.Console`. As you have seen, you do not invoke the `WriteLine()` method from the object level, as shown here:

```
// Compiler error! WriteLine() is not an object level method!
Console c = new Console();
c.WriteLine("I can't be printed...");
```

but instead simply prefix the class name to the static `WriteLine()` member.

```
// Correct! WriteLine() is a static method.
Console.WriteLine("Much better! Thanks...");
```

Simply put, static members are items that are deemed (by the class designer) to be so commonplace that there is no need to create an instance of the class before invoking the member. While any class can define static members, they are quite commonly found within *utility classes*. By definition, a utility class is a class that does not maintain any object-level state and is not created with the `new` keyword. Rather, a utility class exposes all functionality as class-level (aka static) members.

For example, if you were to use the Visual Studio object browser (via the View ► Object Browser menu item) to view the `System` namespace of `mscorlib.dll`, you would see that all the members of the `Console`, `Math`, `Environment`, and `GC` classes (among others) expose all their functionality via static members. These are but a few utility classes found within the .NET base class libraries.

Again, be aware that static members are not only found in utility classes; they can be part of any class definition at all. Just remember that static members promote a given item to the class level rather than the object level. As you will see over the next few sections, the `static` keyword can be applied to the following:

- Data of a class
- Methods of a class
- Properties of a class
- A constructor
- The entire class definition
- In conjunction with the C# `using` keyword

Let's see each of our options, beginning with the concept of static data.

■ **Note** You will examine the role of static properties later in this chapter, while examining the properties themselves.

Defining Static Field Data

Most of the time when designing a class, you define data as instance-level data, said another way, as nonstatic data. When you define instance-level data, you know that every time you create a new object, the object maintains its own independent copy of the data. In contrast, when you define *static* data of a class, the memory is shared by all objects of that category.

To see the distinction, create a new Console Application project named `StaticDataAndMembers`. Now, insert a new class into your project named `SavingsAccount`. Begin by defining a point of instance-level data (to model the current balance) and a custom constructor to set the initial balance.

```
// A simple savings account class.
class SavingsAccount
{
    // Instance-level data.
    public double currBalance;

    public SavingsAccount(double balance)
    {
        currBalance = balance;
    }
}
```

When you create `SavingsAccount` objects, memory for the `currBalance` field is allocated for each object. Thus, you could create five different `SavingsAccount` objects, each with their own unique balance. Furthermore, if you change the balance on one account, the other objects are not affected.

Static data, on the other hand, is allocated once and shared among all objects of the same class category. Add a static point of data named `currInterestRate` to the `SavingsAccount` class, which is set to a default value of 0.04.

```
// A simple savings account class.
class SavingsAccount
{
    // Instance-level data.
    public double currBalance;

    // A static point of data.
    public static double currInterestRate = 0.04;

    public SavingsAccount(double balance)
    {
        currBalance = balance;
    }
}
```

If you were to create three instances of `SavingsAccount` in `Main()` as follows:

```
static void Main(string[] args)
{
    Console.WriteLine("***** Fun with Static Data *****\n");
    SavingsAccount s1 = new SavingsAccount(50);
    SavingsAccount s2 = new SavingsAccount(100);
    SavingsAccount s3 = new SavingsAccount(10000.75);
    Console.ReadLine();
}
```

the in-memory data allocation would look something like Figure 5-3.

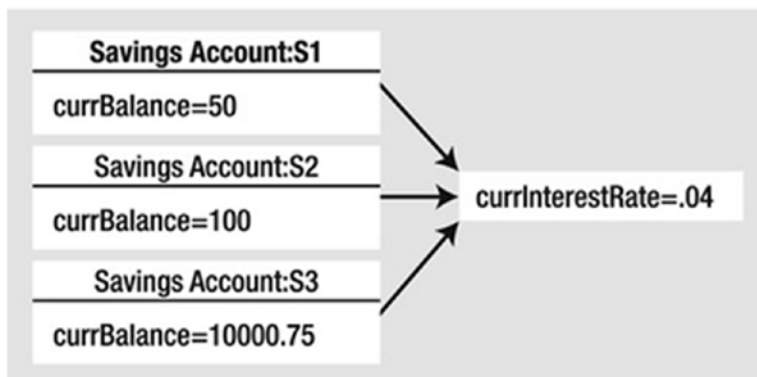

Figure 5-3. Static data is allocated once and shared among all instances of the class

Here, the assumption is that all saving accounts should have the same interest rate. Because static data is shared by all objects of the same category, if you were to change it in any way, all objects will “see” the new value the next time they access the static data, as they are all essentially looking at the same memory location. To understand how to change (or obtain) static data, you need to consider the role of static methods.

Defining Static Methods

Let’s update the `SavingsAccount` class to define two static methods. The first static method (`GetInterestRate()`) will return the current interest rate, while the second static method (`SetInterestRate()`) will allow you to change the interest rate.

```
// A simple savings account class.
class SavingsAccount
{
    // Instance-level data.
    public double currBalance;

    // A static point of data.
    public static double currInterestRate = 0.04;

    public SavingsAccount(double balance)
    {
        currBalance = balance;
    }

    // Static members to get/set interest rate.
    public static void SetInterestRate(double newRate)
    { currInterestRate = newRate; }

    public static double GetInterestRate()
    { return currInterestRate; }
}
```

Now, observe the following usage:

```
static void Main(string[] args)
{
    Console.WriteLine("***** Fun with Static Data *****\n");
    SavingsAccount s1 = new SavingsAccount(50);
    SavingsAccount s2 = new SavingsAccount(100);

    // Print the current interest rate.
    Console.WriteLine("Interest Rate is: {0}", SavingsAccount.GetInterestRate());

    // Make new object, this does NOT 'reset' the interest rate.
    SavingsAccount s3 = new SavingsAccount(10000.75);
    Console.WriteLine("Interest Rate is: {0}", SavingsAccount.GetInterestRate());

    Console.ReadLine();
}
```

The output of the previous `Main()` is shown here:

```
***** Fun with Static Data *****
Interest Rate is: 0.04
Interest Rate is: 0.04
```

As you can see, when you create new instances of the `SavingsAccount` class, the value of the static data is not reset, as the CLR will allocate the static data into memory exactly one time. After that point, all objects of type `SavingsAccount` operate on the same value for the static `currInterestRate` field.

When designing any C# class, one of your design challenges is to determine which pieces of data should be defined as static members and which should not. While there are no hard and fast rules, remember that a static data field is shared by all objects of that type. Therefore, if you are defining a point of data that *all* objects should share between them, static is the way to go.

Consider what would happen if the interest rate variable were *not* defined using the static keyword. This would mean every `SavingsAccount` object would have its own copy of the `currInterestRate` field. Now, assume you created 100 `SavingsAccount` objects and needed to change the interest rate. That would require you to call the `SetInterestRate()` method 100 times! Clearly, this would not be a useful way to model “shared data.” Again, static data is perfect when you have a value that should be common to all objects of that category.

■ **Note** It is a compiler error for a static member to reference nonstatic members in its implementation. On a related note, it is an error to use the `this` keyword on a static member because `this` implies an object!

Defining Static Constructors

A typical constructor is used to set the value of an object’s instance-level data at the time of creation. However, what would happen if you attempted to assign the value of a static point of data in a typical constructor? You might be surprised to find that the value is reset each time you create a new object!

To illustrate, assume you have updated the `SavingsAccount` class constructor as follows (also note you are no longer assigning the `currInterestRate` field inline):

```
class SavingsAccount
{
    public double currBalance;
    public static double currInterestRate;

    // Notice that our constructor is setting
    // the static currInterestRate value.
    public SavingsAccount(double balance)
    {
        currInterestRate = 0.04; // This is static data!
        currBalance = balance;
    }
    ...
}
```

Now, assume you have authored the following code in `Main()`:

```
static void Main( string[] args )
{
    Console.WriteLine("***** Fun with Static Data *****\n");

    // Make an account.
    SavingsAccount s1 = new SavingsAccount(50);

    // Print the current interest rate.
    Console.WriteLine("Interest Rate is: {0}", SavingsAccount.GetInterestRate());

    // Try to change the interest rate via property.
    SavingsAccount.SetInterestRate(0.08);

    // Make a second account.
    SavingsAccount s2 = new SavingsAccount(100);

    // Should print 0.08...right??
    Console.WriteLine("Interest Rate is: {0}", SavingsAccount.GetInterestRate());
    Console.ReadLine();
}
```

If you executed the previous `Main()` method, you would see that the `currInterestRate` variable is reset each time you create a new `SavingsAccount` object, and it is always set to `0.04`. Clearly, setting the value of static data in a normal instance-level constructor sort of defeats the whole purpose. Every time you make a new object, the class-level data is reset! One approach to setting a static field is to use member initialization syntax, as you did originally.

```
class SavingsAccount
{
    public double currBalance;

    // A static point of data.
    public static double currInterestRate = 0.04;
    ...
}
```

This approach will ensure the static field is assigned only once, regardless of how many objects you create. However, what if the value for your static data needed to be obtained at runtime? For example, in a typical banking application, the value of an interest rate variable would be read from a database or external file. Performing such tasks usually requires a method scope such as a constructor to execute the code statements.

For this reason, C# allows you to define a static constructor, which allows you to safely set the values of your static data. Consider the following update to your class:

```
class SavingsAccount
{
    public double currBalance;
    public static double currInterestRate;

    public SavingsAccount(double balance)
    {
        currBalance = balance;
    }

    // A static constructor!
    static SavingsAccount()
    {
        Console.WriteLine("In static ctor!");
        currInterestRate = 0.04;
    }
    ...
}
```

Simply put, a static constructor is a special constructor that is an ideal place to initialize the values of static data when the value is not known at compile time (e.g., you need to read in the value from an external file, read in the value from a database, generate a random number, or whatnot). If you were to rerun the previous `Main()` method, you would find the output you expect. Note that the message “In static ctor!” prints only one time, as the CLR calls all static constructors before the first use (and never calls them again for that instance of the application).

```
***** Fun with Static Data *****
```

```
In static ctor!
Interest Rate is: 0.04
Interest Rate is: 0.08
```

Here are a few points of interest regarding static constructors:

- A given class may define only a single static constructor. In other words, the static constructor cannot be overloaded.
- A static constructor does not take an access modifier and cannot take any parameters.
- A static constructor executes exactly one time, regardless of how many objects of the type are created.
- The runtime invokes the static constructor when it creates an instance of the class or before accessing the first static member invoked by the caller.
- The static constructor executes before any instance-level constructors.

Given this modification, when you create new `SavingsAccount` objects, the value of the static data is preserved, as the static member is set only one time within the static constructor, regardless of the number of objects created.

■ **Source Code** The `StaticDataAndMembers` project is included in the [Chapter 5](#) subdirectory.

Defining Static Classes

It is also possible to apply the `static` keyword directly on the class level. When a class has been defined as static, it is not creatable using the `new` keyword, and it can contain only members or data fields marked with the `static` keyword. If this is not the case, you receive compiler errors.

■ **Note** Recall that a class (or structure) that exposes only static functionality is often termed a *utility class*. When designing a utility class, it is good practice to apply the `static` keyword to the class definition.

At first glance, this might seem like a fairly odd feature, given that a class that cannot be created does not appear all that helpful. However, if you create a class that contains nothing but static members and/or constant data, the class has no need to be allocated in the first place! To illustrate, create a new Console Application project named `SimpleUtilityClass`. Next, define the following class:

```
// Static classes can only
// contain static members!
static class TimeUtilClass
{
    public static void PrintTime()
    { Console.WriteLine(DateTime.Now.ToShortTimeString()); }

    public static void PrintDate()
    { Console.WriteLine(DateTime.Today.ToShortDateString()); }
}
```

Given that this class has been defined with the `static` keyword, you cannot create an instance of `TimeUtilClass` using the `new` keyword. Rather, all functionality is exposed from the class level.

```
static void Main(string[] args)
{
    Console.WriteLine("***** Fun with Static Classes *****\n");

    // This is just fine.
    TimeUtilClass.PrintDate();
    TimeUtilClass.PrintTime();

    // Compiler error! Can't create instance of static classes!
    TimeUtilClass u = new TimeUtilClass ();

    Console.ReadLine();
}
```

Importing Static Members via the C# using Keyword

The latest version of the C# compiler supports a new way to use the `using` keyword. It is now possible to define a C# `using` directive, which will import all static members into the declaring code file. To illustrate, consider the C# file currently defining the utility class. Because you are making calls to the `WriteLine()` method of the `Console` class, as well as the `Now` property of the `DateTime` class, you must have a `using` statement for the `System` namespace. Since the members of these classes are all static, you could alter your code file with the following *static using directives*:

```
// Import the static members of Console and DateTime.
using static System.Console;
using static System.DateTime;
```

With these “static imports,” the remainder of your code file is able to directly use the static members of the `Console` and `DateTime` class, without the need to prefix the defining class (although that would still be just fine, provided that you have imported the `System` namespace). For example, you could update your utility class like so:

```
static class TimeUtilClass
{
    public static void PrintTime()
    { WriteLine(Now.ToShortTimeString()); }

    public static void PrintDate()
    { WriteLine(Today.ToShortDateString()); }
}
```

You could argue that this iteration of the class is a bit cleaner in that you have a slightly smaller code base. A more realistic example of code simplification might involve a C# class that is making substantial use of the `System.Math` class (or some other utility class). Since this class has nothing but static members, it could be somewhat easier to have a static `using` statement for this type and then directly call into the members of the `Math` class in your code file.

However, be aware that overuse of static import statements could result in potential confusion. First, what if multiple classes define a `WriteLine()` method? The compiler is confused and so are others reading your code. Second, unless a developer is familiar with the .NET code libraries, he or she might not know that `WriteLine()` is a member of the `Console` class. Unless a person were to notice the set of static imports at the top of a C# code file, they might be quite unsure where this method is actually defined. For these reasons, I will limit the use of static `using` statements in this text.

In any case, at this point in the chapter, you should feel comfortable defining simple class types containing constructors, fields, and various static (and nonstatic) members. Now that you have the basics of class construction under your belt, you can formally investigate the three pillars of object-oriented programming.

■ **Source Code** The `SimpleUtilityClass` project is located in the Chapter 5 subdirectory.

Defining the Pillars of OOP

All object-oriented languages (C#, Java, C++, Visual Basic, etc.) must contend with three core principles, often called the *pillars* of object-oriented programming (OOP).

- *Encapsulation*: How does this language hide an object's internal implementation details and preserve data integrity?
- *Inheritance*: How does this language promote code reuse?
- *Polymorphism*: How does this language let you treat related objects in a similar way?

Before digging into the syntactic details of each pillar, it is important that you understand the basic role of each. Here is an overview of each pillar, which will be examined in full detail over the remainder of this chapter and the next.

The Role of Encapsulation

The first pillar of OOP is called *encapsulation*. This trait boils down to the language's ability to hide unnecessary implementation details from the object user. For example, assume you are using a class named `DatabaseReader`, which has two primary methods named `Open()` and `Close()`.

```
// Assume this class encapsulates the details of opening and closing a database.
DatabaseReader dbReader = new DatabaseReader();
dbReader.Open(@"C:\AutoLot.mdf");

// Do something with data file and close the file.
dbReader.Close();
```

The fictitious `DatabaseReader` class encapsulates the inner details of locating, loading, manipulating, and closing a data file. Programmers love encapsulation, as this pillar of OOP keeps coding tasks simpler. There is no need to worry about the numerous lines of code that are working behind the scenes to carry out the work of the `DatabaseReader` class. All you do is create an instance and send the appropriate messages (e.g., “Open the file named `AutoLot.mdf` located on my C drive”).

Closely related to the notion of encapsulating programming logic is the idea of data protection. Ideally, an object's state data should be specified using the `private` (or possibly `protected`) keyword. In this way, the outside world must ask politely in order to change or obtain the underlying value. This is a good thing, as publicly declared data points can easily become corrupted (ideally by accident rather than intent!). You will formally examine this aspect of encapsulation in just a bit.

The Role of Inheritance

The next pillar of OOP, *inheritance*, boils down to the language's ability to allow you to build new class definitions based on existing class definitions. In essence, inheritance allows you to extend the behavior of a base (or *parent*) class by inheriting core functionality into the derived subclass (also called a *child class*). Figure 5-4 shows a simple example.

You can read the diagram in Figure 5-4 as “A Hexagon is-a Shape that is-an Object.” When you have classes related by this form of inheritance, you establish “*is-a*” relationships between types. The “*is-a*” relationship is termed *inheritance*.

Here, you can assume that `Shape` defines some number of members that are common to all descendants (maybe a value to represent the color to draw the shape and other values to represent the height and width). Given that the `Hexagon` class extends `Shape`, it inherits the core functionality defined by `Shape` and `Object`, as well as defines additional hexagon-related details of its own (whatever those may be).

■ **Note** Under the .NET platform, `System.Object` is always the topmost parent in any class hierarchy, which defines some general functionality for all types (fully described in Chapter 6).

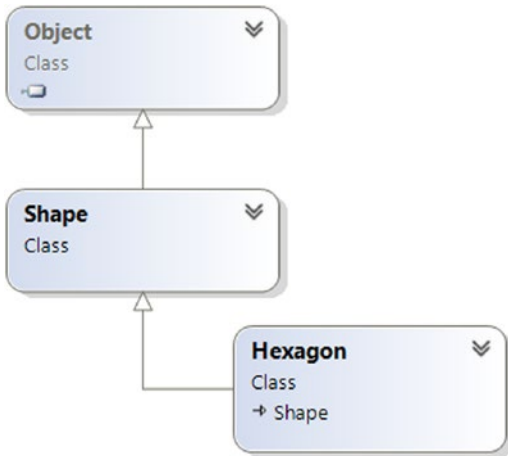

Figure 5-4. The “is-a” relationship

There is another form of code reuse in the world of OOP: the containment/delegation model also known as the “has-a” relationship or aggregation. This form of reuse is not used to establish parent-child relationships. Rather, the “has-a” relationship allows one class to define a member variable of another class and expose its functionality (if required) to the object user indirectly.

For example, assume you are again modeling an automobile. You might want to express the idea that a car “has-a” radio. It would be illogical to attempt to derive the `Car` class from a `Radio`, or vice versa (a `Car` “is-a” `Radio`? I think not!). Rather, you have two independent classes working together, where the `Car` class creates and exposes the `Radio`’s functionality.

```

class Radio
{
    public void Power(bool turnOn)
    {
        Console.WriteLine("Radio on: {0}", turnOn);
    }
}
  
```

```

class Car
{
    // Car 'has-a' Radio.
    private Radio myRadio = new Radio();
  
```

```

public void TurnOnRadio(bool onOff)
{
    // Delegate call to inner object.
    myRadio.Power(onOff);
}
}

```

Notice that the object user has no clue that the Car class is using an inner Radio object.

```

static void Main(string[] args)
{
    // Call is forwarded to Radio internally.
    Car viper = new Car();
    viper.TurnOnRadio(false);
}

```

The Role of Polymorphism

The final pillar of OOP is *polymorphism*. This trait captures a language's ability to treat related objects in a similar manner. Specifically, this tenant of an object-oriented language allows a base class to define a set of members (formally termed the *polymorphic interface*) that are available to all descendants. A class's polymorphic interface is constructed using any number of *virtual* or *abstract* members (see Chapter 6 for full details).

In a nutshell, a *virtual member* is a member in a base class that defines a default implementation that may be changed (or more formally speaking, *overridden*) by a derived class. In contrast, an *abstract method* is a member in a base class that does not provide a default implementation but does provide a signature. When a class derives from a base class defining an abstract method, it *must* be overridden by a derived type. In either case, when derived types override the members defined by a base class, they are essentially redefining how they respond to the same request.

To preview polymorphism, let's provide some details behind the shapes hierarchy shown in Figure 5-5. Assume that the Shape class has defined a virtual method named `Draw()` that takes no parameters. Given that every shape needs to render itself in a unique manner, subclasses such as Hexagon and Circle are free to override this method to their own liking (see Figure 5-5).

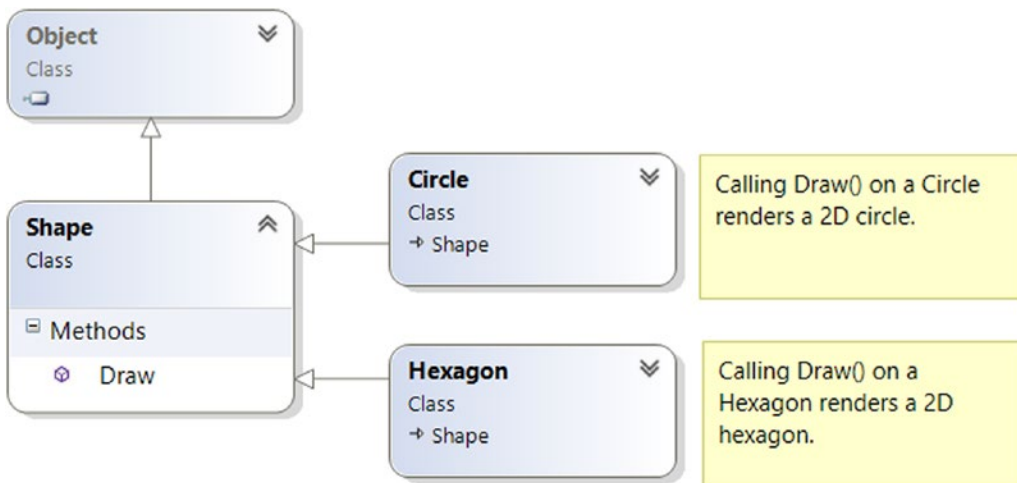

Figure 5-5. Classical polymorphism

After a polymorphic interface has been designed, you can begin to make various assumptions in your code. For example, given that **Hexagon** and **Circle** derive from a common parent (**Shape**), an array of **Shape** types could contain anything deriving from this base class. Furthermore, given that **Shape** defines a polymorphic interface to all derived types (the **Draw()** method in this example), you can assume each member in the array has this functionality.

Consider the following **Main()** method, which instructs an array of **Shape**-derived types to render themselves using the **Draw()** method:

```

class Program
{
    static void Main(string[] args)
    {
        Shape[] myShapes = new Shape[3];
        myShapes[0] = new Hexagon();
        myShapes[1] = new Circle();
        myShapes[2] = new Hexagon();

        foreach (Shape s in myShapes)
        {
            // Use the polymorphic interface!
            s.Draw();
        }
        Console.ReadLine();
    }
}
  
```

This wraps up our brisk overview of the pillars of OOP. Now that you have the theory in your mind, the remainder of this chapter explores further details of how encapsulation is handled under **C#**. Chapter 6 will tackle the details of inheritance and polymorphism.

C# Access Modifiers

When working with encapsulation, you must always take into account which aspects of a type are visible to various parts of your application. Specifically, types (classes, interfaces, structures, enumerations, and delegates) as well as their members (properties, methods, constructors, and fields) are defined using a specific keyword to control how “visible” the item is to other parts of your application. Although C# defines numerous keywords to control access, they differ on where they can be successfully applied (type or member). Table 5-1 documents the role of each access modifier and where it may be applied.

Table 5-1. C# Access Modifiers

| C# Access Modifier | May Be Applied To | Meaning in Life |
|--------------------|------------------------------|---|
| public | Types or type members | Public items have no access restrictions. A public member can be accessed from an object, as well as any derived class. A public type can be accessed from other external assemblies. |
| private | Type members or nested types | Private items can be accessed only by the class (or structure) that defines the item. |
| protected | Type members or nested types | Protected items can be used by the class that defines it and any child class. However, protected items cannot be accessed from the outside world using the C# dot operator. |
| internal | Types or type members | Internal items are accessible only within the current assembly. Therefore, if you define a set of internal types within a .NET class library, other assemblies are not able to use them. |
| protected internal | Type members or nested types | When the <code>protected</code> and <code>internal</code> keywords are combined on an item, the item is accessible within the defining assembly, within the defining class, and by derived classes. |

In this chapter, you are concerned only with the `public` and `private` keywords. Later chapters will examine the role of the `internal` and `protected internal` modifiers (useful when you build .NET code libraries) and the `protected` modifier (useful when you are creating class hierarchies).

The Default Access Modifiers

By default, type members are *implicitly private* while types are *implicitly internal*. Thus, the following class definition is automatically set to `internal`, while the type’s default constructor is automatically set to `private` (however, as you would suspect, there are few times you would want a private class constructor):

```
// An internal class with a private default constructor.
class Radio
{
    Radio(){ }
}
```

If you want to be explicit, you could add these keywords yourself with no ill effect (beyond a few additional keystrokes).

```
// An internal class with a private default constructor.
internal class Radio
{
    private Radio(){}
```

To allow other parts of a program to invoke members of an object, you must define them with the `public` keyword (or possibly with the `protected` keyword, which you will learn about in the next chapter). As well, if you want to expose the `Radio` to external assemblies (again, useful when building .NET code libraries; see Chapter 14), you will need to add the `public` modifier.

```
// A public class with a public default constructor.
public class Radio
{
    public Radio(){}
```

Access Modifiers and Nested Types

As mentioned in Table 5-1, the `private`, `protected`, and `protected internal` access modifiers can be applied to a *nested type*. Chapter 6 will examine nesting in detail. What you need to know at this point, however, is that a nested type is a type declared directly within the scope of class or structure. By way of example, here is a private enumeration (named `CarColor`) nested within a public class (named `SportsCar`):

```
public class SportsCar
{
    // OK! Nested types can be marked private.
    private enum CarColor
    {
        Red, Green, Blue
    }
}
```

Here, it is permissible to apply the `private` access modifier on the nested type. However, nonnested types (such as the `SportsCar`) can be defined only with the `public` or `internal` modifiers. Therefore, the following class definition is illegal:

```
// Error! Nonnested types cannot be marked private!
private class SportsCar
{}
```

The First Pillar: C#'s Encapsulation Services

The concept of encapsulation revolves around the notion that an object's data should not be directly accessible from an object instance. Rather, class data is defined as private. If the object user wants to alter the state of an object, it does so indirectly using public members. To illustrate the need for encapsulation services, assume you have created the following class definition:

```
// A class with a single public field.
class Book
{
    public int numberOfPages;
}
```

The problem with public data is that the data itself has no ability to “understand” whether the current value to which they are assigned is valid with regard to the current business rules of the system. As you know, the upper range of a C# `int` is quite large (2,147,483,647). Therefore, the compiler allows the following assignment:

```
// Humm. That is one heck of a mini-novel!
static void Main(string[] args)
{
    Book miniNovel = new Book();
    miniNovel.numberOfPages = 30000000;
}
```

Although you have not overflowed the boundaries of an `int` data type, it should be clear that a mini novel with a page count of 30,000,000 pages is a bit unreasonable. As you can see, public fields do not provide a way to trap logical upper (or lower) limits. If your current system has a business rule that states a book must be between 1 and 1,000 pages, you are at a loss to enforce this programmatically. Because of this, public fields typically have no place in a production-level class definition.

■ **Note** To be more specific, members of a class that represent an object's state should not be marked as public. As you will see later in this chapter, public constants and public read-only fields are quite useful.

Encapsulation provides a way to preserve the integrity of an object's state data. Rather than defining public fields (which can easily foster data corruption), you should get in the habit of defining *private data*, which is indirectly manipulated using one of two main techniques.

- You can define a pair of public accessor (get) and mutator (set) methods.
- You can define a public .NET property.

Whichever technique you choose, the point is that a well-encapsulated class should protect its data and hide the details of how it operates from the prying eyes of the outside world. This is often termed *black-box programming*. The beauty of this approach is that an object is free to change how a given method is implemented under the hood. It does this without breaking any existing code making use of it, provided that the parameters and return values of the method remain constant.

Encapsulation Using Traditional Accessors and Mutators

Over the remaining pages in this chapter, you will be building a fairly complete class that models a general employee. To get the ball rolling, create a new Console Application project named `EmployeeApp` and insert a new class file (named `Employee.cs`) using the Project Add class menu item. Update the `Employee` class with the following fields, methods, and constructors:

```
class Employee
{
    // Field data.
    private string empName;
    private int empID;
    private float currPay;

    // Constructors.
    public Employee() {}
    public Employee(string name, int id, float pay)
    {
        empName = name;
        empID = id;
        currPay = pay;
    }

    // Methods.
    public void GiveBonus(float amount)
    {
        currPay += amount;
    }

    public void DisplayStats()
    {
        Console.WriteLine("Name: {0}", empName);
        Console.WriteLine("ID: {0}", empID);
        Console.WriteLine("Pay: {0}", currPay);
    }
}
```

Notice that the fields of the `Employee` class are currently defined using the `private` keyword. Given this, the `empName`, `empID`, and `currPay` fields are not directly accessible from an object variable. Therefore, the following logic in `Main()` would result in compiler errors:

```
static void Main(string[] args)
{
    Employee emp = new Employee();

    // Error! Cannot directly access private members
    // from an object!
    emp.empName = "Marv";
}
```

If you want the outside world to interact with a worker's full name, a traditional approach (which is common in Java) is to define an accessor (get method) and a mutator (set method). The role of a get method is to return to the caller the current value of the underlying state data. A set method allows the caller to change the current value of the underlying state data, as long as the defined business rules are met.

To illustrate, let's encapsulate the empName field. To do so, add the following public methods to the Employee class. Notice that the SetName() method performs a test on the incoming data to ensure the string is 15 characters or less. If it is not, an error prints to the console and returns without making a change to the empName field.

■ **Note** If this were a production-level class, you would also make to check the character length for an employee's name within your constructor logic. Ignore this detail for the time being, as you will clean up this code in just a bit when you examine .NET property syntax.

```
class Employee
{
    // Field data.
    private string empName;
    ...

    // Accessor (get method).
    public string GetName()
    {
        return empName;
    }

    // Mutator (set method).
    public void SetName(string name)
    {
        // Do a check on incoming value
        // before making assignment.
        if (name.Length > 15)
            Console.WriteLine("Error! Name length exceeds 15 characters!");
        else
            empName = name;
    }
}
```

This technique requires two uniquely named methods to operate on a single data point. To test your new methods, update your Main() method as follows:

```
static void Main(string[] args)
{
    Console.WriteLine("***** Fun with Encapsulation *****\n");
    Employee emp = new Employee("Marvin", 456, 30000);
    emp.GiveBonus(1000);
    emp.DisplayStats();
}
```

```

// Use the get/set methods to interact with the object's name.
emp.SetName("Marv");
Console.WriteLine("Employee is named: {0}", emp.GetName());
Console.ReadLine();
}

```

Because of the code in your `SetName()` method, if you attempted to specify more than 15 characters (see the following), you would find the hard-coded error message printed to the console.

```

static void Main(string[] args)
{
    Console.WriteLine("***** Fun with Encapsulation *****\n");
    ...
    // Longer than 15 characters! Error will print to console.
    Employee emp2 = new Employee();
    emp2.SetName("Xena the warrior princess");

    Console.ReadLine();
}

```

So far, so good. You have encapsulated the private `empName` field using two public methods named `GetName()` and `SetName()`. If you were to further encapsulate the data in the `Employee` class, you would need to add various additional methods (such as `GetID()`, `SetID()`, `GetCurrentPay()`, `SetCurrentPay()`). Each of the mutator methods could have within it various lines of code to check for additional business rules. While this could certainly be done, the C# language has a useful alternative notation to encapsulate class data.

Encapsulation Using .NET Properties

Although you can encapsulate a piece of field data using traditional get and set methods, .NET languages prefer to enforce data encapsulation state data using *properties*. First, understand that properties are just a simplification for “real” accessor and mutator methods. Therefore, as a class designer, you are still able to perform any internal logic necessary before making the value assignment (e.g., uppercase the value, scrub the value for illegal characters, check the bounds of a numerical value, and so on).

Here is the updated `Employee` class, now enforcing encapsulation of each field using property syntax rather than traditional get and set methods:

```

class Employee
{
    // Field data.
    private string empName;
    private int empID;
    private float currPay;

    // Properties!
    public string Name
    {
        get { return empName; }
        set
        {
            if (value.Length > 15)

```

```

        Console.WriteLine("Error! Name length exceeds 15 characters!");
    else
        empName = value;
    }
}

// We could add additional business rules to the sets of these properties;
// however, there is no need to do so for this example.
public int ID
{
    get { return empID; }
    set { empID = value; }
}
public float Pay
{
    get { return currPay; }
    set { currPay = value; }
}
...
}

```

A C# property is composed by defining a get scope (accessor) and set scope (mutator) directly within the property itself. Notice that the property specifies the type of data it is encapsulating by what appears to be a return value. Also take note that, unlike a method, properties do not make use of parentheses (not even empty parentheses) when being defined. Consider the following commentary on your current ID property:

```

// The 'int' represents the type of data this property encapsulates.
public int ID // Note lack of parentheses.
{
    get { return empID; }
    set { empID = value; }
}

```

Within a set scope of a property, you use a token named *value*, which is used to represent the incoming value used to assign the property by the caller. This token is *not* a true C# keyword but is what is known as a *contextual keyword*. When the token *value* is within the set scope of the property, it always represents the value being assigned by the caller, and it will always be the same underlying data type as the property itself. Thus, notice how the *Name* property can still test the range of the *string* as so:

```

public string Name
{
    get { return empName; }
    set
    {
        // Here, value is really a string.
        if (value.Length > 15)
            Console.WriteLine("Error! Name length exceeds 15 characters!");
        else
            empName = value;
    }
}

```

After you have these properties in place, it appears to the caller that it is getting and setting a *public point* of data; however, the correct get and set block is called behind the scenes to preserve encapsulation.

```
static void Main(string[] args)
{
    Console.WriteLine("***** Fun with Encapsulation *****\n");
    Employee emp = new Employee("Marvin", 456, 30000);
    emp.GiveBonus(1000);
    emp.DisplayStats();

    // Reset and then get the Name property.
    emp.Name = "Marv";
    Console.WriteLine("Employee is named: {0}", emp.Name);
    Console.ReadLine();
}
```

Properties (as opposed to accessor and mutator methods) also make your types easier to manipulate, in that properties are able to respond to the intrinsic operators of C#. To illustrate, assume that the `Employee` class type has an internal private member variable representing the age of the employee. Here is the relevant update (notice the use of constructor chaining):

```
class Employee
{
    ...
    // New field and property.
    private int empAge;
    public int Age
    {
        get { return empAge; }
        set { empAge = value; }
    }

    // Updated constructors.
    public Employee() {}
    public Employee(string name, int id, float pay)
        :this(name, 0, id, pay){}

    public Employee(string name, int age, int id, float pay)
    {
        empName = name;
        empID = id;
        empAge = age;
        currPay = pay;
    }
}
```

```

// Updated DisplayStats() method now accounts for age.
public void DisplayStats()
{
    Console.WriteLine("Name: {0}", empName);
    Console.WriteLine("ID: {0}", empID);
    Console.WriteLine("Age: {0}", empAge);
    Console.WriteLine("Pay: {0}", currPay);
}
}

```

Now assume you have created an `Employee` object named `joe`. On his birthday, you want to increment the age by one. Using traditional accessor and mutator methods, you would need to write code such as the following:

```

Employee joe = new Employee();
joe.SetAge(joe.GetAge() + 1);

```

However, if you encapsulate `empAge` using a property named `Age`, you are able to simply write this:

```

Employee joe = new Employee();
joe.Age++;

```

Using Properties Within a Class Definition

Properties, specifically the set portion of a property, are common places to package up the business rules of your class. Currently, the `Employee` class has a `Name` property that ensures the name is no more than 15 characters. The remaining properties (`ID`, `Pay`, and `Age`) could also be updated with any relevant logic.

While this is well and good, also consider what a class constructor typically does internally. It will take the incoming parameters, check for valid data, and then make assignments to the internal private fields. Currently, your master constructor does *not* test the incoming string data for a valid range, so you could update this member as so:

```

public Employee(string name, int age, int id, float pay)
{
    // Humm, this seems like a problem...
    if (name.Length > 15)
        Console.WriteLine("Error! Name length exceeds 15 characters!");
    else
        empName = name;

    empID = id;
    empAge = age;
    currPay = pay;
}

```

I am sure you can see the problem with this approach. The Name property and your master constructor are performing the same error checking. If you were also making checks on the other data points, you would have a good deal of duplicate code. To streamline your code and isolate all of your error checking to a central location, you will do well if you *always* use properties within your class whenever you need to get or set the values. Consider the following updated constructor:

```
public Employee(string name, int age, int id, float pay)
{
    // Better! Use properties when setting class data.
    // This reduces the amount of duplicate error checks.
    Name = name;
    Age = age;
    ID = id;
    Pay = pay;
}
```

Beyond updating constructors to use properties when assigning values, it is good practice to use properties throughout a class implementation to ensure your business rules are always enforced. In many cases, the only time when you directly make reference to the underlying private piece of data is within the property itself. With this in mind, here is your updated Employee class:

```
class Employee
{
    // Field data.
    private string empName;
    private int empID;
    private float currPay;
    private int empAge;

    // Constructors.
    public Employee() { }
    public Employee(string name, int id, float pay)
        :this(name, 0, id, pay){}
    public Employee(string name, int age, int id, float pay)
    {
        Name = name;
        Age = age;
        ID = id;
        Pay = pay;
    }

    // Methods.
    public void GiveBonus(float amount)
    { Pay += amount; }
```

```

public void DisplayStats()
{
    Console.WriteLine("Name: {0}", Name);
    Console.WriteLine("ID: {0}", ID);
    Console.WriteLine("Age: {0}", Age);
    Console.WriteLine("Pay: {0}", Pay);
}

// Properties as before...
...
}

```

Read-Only and Write-Only Properties

When encapsulating data, you might want to configure a *read-only property*. To do so, simply omit the set block. Likewise, if you want to have a *write-only property*, omit the get block. For example, assume you have a new property named `SocialSecurityNumber`, which encapsulates a private string variable named `empSSN`. If you want to make this a read-only property, you could write this:

```

public string SocialSecurityNumber
{
    get { return empSSN; }
}

```

Now assume your class constructor has a new parameter to let the caller set the SSN of the object. Since the `SocialSecurityNumber` property is read-only, you cannot set the value as so:

```

public Employee(string name, int age, int id, float pay, string ssn)
{
    Name = name;
    Age = age;
    ID = id;
    Pay = pay;

    // OOPS! This is no longer possible if the property is read only.
    SocialSecurityNumber = ssn;
}

```

Unless you are willing to redesign the property as read-write, your only choice would be to use the underlying `empSSN` member variable within your constructor logic as so:

```

public Employee(string name, int age, int id, float pay, string ssn)
{
    ...
    // Check incoming ssn parameter as required and then set the value.
    empSSN = ssn;
}

```

■ **Source Code** The EmployeeApp project can be found under the Chapter 5 subdirectory.

Revisiting the static Keyword: Defining Static Properties

Earlier in this chapter, you examined the role of the `static` keyword. Now that you understand the use of C# property syntax, you can formalize static properties. In the `StaticDataAndMembers` project created earlier in this chapter, your `SavingsAccount` class had two public static methods to get and set the interest rate. However, it would be more standard to wrap this data point in a static property. Here's an example (note the use of the `static` keyword):

```
// A simple savings account class.
class SavingsAccount
{
    // Instance-level data.
    public double currBalance;

    // A static point of data.
    private static double currInterestRate = 0.04;

    // A static property.
    public static double InterestRate
    {
        get { return currInterestRate; }
        set { currInterestRate = value; }
    }
    ...
}
```

If you want to use this property in place of the previous static methods, you could update your `Main()` method as so:

```
// Print the current interest rate via property.
Console.WriteLine("Interest Rate is: {0}", SavingsAccount.InterestRate);
```

Understanding Automatic Properties

When you are building properties to encapsulate your data, it is common to find that the set scopes have code to enforce business rules of your program. However, in some cases you may not need any implementation logic beyond simply getting and setting the value. This means you can end up with a lot of code looking like the following:

```
// A Car type using standard property
// syntax.
class Car
{
    private string carName = "";
    public string PetName
```

```

    {
        get { return carName; }
        set { carName = value; }
    }
}

```

In these cases, it can become rather verbose to define private backing fields and simple property definitions multiple times. By way of an example, if you are modeling a class that requires nine private points of field data, you end up authoring nine related properties that are little more than thin wrappers for encapsulation services.

To streamline the process of providing simple encapsulation of field data, you may use *automatic property syntax*. As the name implies, this feature will offload the work of defining a private backing field and the related C# property member to the compiler using a new bit of syntax. To illustrate, create a new Console Application project named AutoProps. Now, consider the reworking of the Car class, which uses this syntax to quickly create three properties:

```

class Car
{
    // Automatic properties! No need to define backing fields.
    public string PetName { get; set; }
    public int Speed { get; set; }
    public string Color { get; set; }
}

```

■ **Note** Visual Studio provides the `prop` code snippet. If you type **prop** inside a class definition and press the Tab key twice, the IDE will generate starter code for a new automatic property. You can then use the Tab key to cycle through each part of the definition to fill in the details. Give it a try!

When defining automatic properties, you simply specify the access modifier, underlying data type, property name, and empty get/set scopes. At compile time, your type will be provided with an autogenerated private backing field and a fitting implementation of the get/set logic.

■ **Note** The name of the autogenerated private backing field is not visible within your C# code base. The only way to see it is to make use of a tool such as `ildasm.exe`.

With the current version of C#, it is now possible to define a “read-only automatic property” by omitting the set scope. However, it is not possible to define a write-only property. To solidify, consider the following:

```

// Read-only property? This is OK!
public int MyReadOnlyProp { get; }

// Write only property? Error!
public int MyWriteOnlyProp { set; }

```

Interacting with Automatic Properties

Because the compiler will define the private backing field at compile time (and given that these fields are not directly accessible in C# code), the class defining automatic properties will always need to use property syntax to get and set the underlying value. This is important to note because many programmers make direct use of the private fields *within* a class definition, which is not possible in this case. For example, if the Car class were to provide a `DisplayStats()` method, it would need to implement this method using the property name.

```
class Car
{
    // Automatic properties!
    public string PetName { get; set; }
    public int Speed { get; set; }
    public string Color { get; set; }

    public void DisplayStats()
    {
        Console.WriteLine("Car Name: {0}", PetName);
        Console.WriteLine("Speed: {0}", Speed);
        Console.WriteLine("Color: {0}", Color);
    }
}
```

When you are using an object defined with automatic properties, you will be able to assign and obtain the values using the expected property syntax.

```
static void Main(string[] args)
{
    Console.WriteLine("***** Fun with Automatic Properties *****\n");

    Car c = new Car();
    c.PetName = "Frank";
    c.Speed = 55;
    c.Color = "Red";

    Console.WriteLine("Your car is named {0}? That's odd...",
        c.PetName);
    c.DisplayStats();

    Console.ReadLine();
}
```

Automatic Properties and Default Values

When you use automatic properties to encapsulate numerical or Boolean data, you are able to use the autogenerated type properties straightaway within your code base, as the hidden backing fields will be assigned a safe default value (false for Booleans and 0 for numerical data). However, be aware that if you use automatic property syntax to wrap another class variable, the hidden private reference type will also be set to a default value of null (which can prove problematic if you are not careful).

Let's insert into your current project a new class named `Garage`, which makes use of two automatic properties (of course, a real garage class might maintain a collection of `Car` objects; however, ignore that detail here).

```
class Garage
{
    // The hidden int backing field is set to zero!
    public int NumberOfCars { get; set; }

    // The hidden Car backing field is set to null!
    public Car MyAuto { get; set; }
}
```

Given C#'s default values for field data, you would be able to print out the value of `NumberOfCars` as is (as it is automatically assigned the value of zero), but if you directly invoke `MyAuto`, you will receive a “null reference exception” at runtime, as the `Car` member variable used in the background has not been assigned to a new object.

```
static void Main(string[] args)
{
    ...
    Garage g = new Garage();

    // OK, prints default value of zero.
    Console.WriteLine("Number of Cars: {0}", g.NumberOfCars);

    // Runtime error! Backing field is currently null!
    Console.WriteLine(g.MyAuto.PetName);
    Console.ReadLine();
}
```

To solve this problem, you could update the class constructors to ensure the object comes to life in a safe manner. Here's an example:

```
class Garage
{
    // The hidden backing field is set to zero!
    public int NumberOfCars { get; set; }

    // The hidden backing field is set to null!
    public Car MyAuto { get; set; }

    // Must use constructors to override default
    // values assigned to hidden backing fields.
    public Garage()
```



```

    {
        MyAuto = new Car();
        NumberOfCars = 1;
    }
    public Garage(Car car, int number)
    {
        MyAuto = car;
        NumberOfCars = number;
    }
}

```

With this modification, you could now place a Car object into the Garage object as so:

```

static void Main(string[] args)
{
    Console.WriteLine("***** Fun with Automatic Properties *****\n");

    // Make a car.
    Car c = new Car();
    c.PetName = "Frank";
    c.Speed = 55;
    c.Color = "Red";
    c.DisplayStats();

    // Put car in the garage.
    Garage g = new Garage();
    g.MyAuto = c;
    Console.WriteLine("Number of Cars in garage: {0}", g.NumberOfCars);
    Console.WriteLine("Your car is named: {0}", g.MyAuto.PetName);

    Console.ReadLine();
}

```

Initialization of Automatic Properties

While the previous approach works just fine, with the release of the latest version of the C# language, you are provided with a new language feature that can simplify how an automatic property receives its initial value assignment. Recall from the onset of this chapter, a data field of a class can be directly assigned an initial value upon declaration. Here's an example:

```

class Car
{
    private int numberOfDoors = 2;
}

```

In a similar manner, C# now allows you to assign an initial value to the underlying backing field generated by the compiler. This alleviates you from the hassle of adding additional code statements in class constructors to ensure property data comes to life as intended.

Here is an updated version of the `Garage` class that is initializing automatic properties to fitting values. Note you no longer need to add additional logic to your default class constructor to make safe assignments. In this iteration, you are directly assigning a new `Car` object to the `MyAuto` property.

```
class Garage
{
    // The hidden backing field is set to 1.
    public int NumberOfCars { get; set; } = 1;

    // The hidden backing field is set to a new Car object.
    public Car MyAuto { get; set; } = new Car();

    public Garage(){ }
    public Garage(Car car, int number)
    {
        MyAuto = car;
        NumberOfCars = number;
    }
}
```

As you may agree, automatic properties are a nice feature of the `C#` programming language, as you can define a number of properties for a class using a streamlined syntax. Be aware of course that if you are building a property that requires additional code beyond getting and setting the underlying private field (such as data validation logic, writing to an event log, communicating with a database, etc.), you will be required to define a “normal” `.NET` property type by hand. `C#` automatic properties never do more than provide simple encapsulation for an underlying piece of (compiler-generated) private data.

■ **Source Code** The `AutoProps` project can be found in the [Chapter 5](#) subdirectory.

Understanding Object Initialization Syntax

As shown throughout this chapter, a constructor allows you specify startup values when creating a new object. On a related note, properties allow you to get and set underlying data in a safe manner. When you are working with other people’s classes, including the classes found within the `.NET` base class library, it is not too uncommon to discover that there is not a single constructor that allows you to set every piece of underlying state data. Given this point, a programmer is typically forced to pick the best constructor possible, after which the programmer makes assignments using a handful of provided properties.

To help streamline the process of getting an object up and running, `C#` offers *object initializer syntax*. Using this technique, it is possible to create a new object variable and assign a slew of properties and/or public fields in a few lines of code. Syntactically, an object initializer consists of a comma-delimited list of specified values, enclosed by the `{` and `}` tokens. Each member in the initialization list maps to the name of a public field or public property of the object being initialized.

To see this syntax in action, create a new Console Application project named `ObjectInitializers`. Now, consider a simple class named `Point`, created using automatic properties (which is not mandatory for object initialization syntax but helps you write some concise code).

```
class Point
{
    public int X { get; set; }
    public int Y { get; set; }

    public Point(int xVal, int yVal)
    {
        X = xVal;
        Y = yVal;
    }
    public Point() { }

    public void DisplayStats()
    {
        Console.WriteLine("[{0}, {1}]", X, Y);
    }
}
```

Now consider how you can make `Point` objects using any of the following approaches:

```
static void Main(string[] args)
{
    Console.WriteLine("***** Fun with Object Init Syntax *****\n");

    // Make a Point by setting each property manually.
    Point firstPoint = new Point();
    firstPoint.X = 10;
    firstPoint.Y = 10;
    firstPoint.DisplayStats();

    // Or make a Point via a custom constructor.
    Point anotherPoint = new Point(20, 20);
    anotherPoint.DisplayStats();

    // Or make a Point using object init syntax.
    Point finalPoint = new Point { X = 30, Y = 30 };
    finalPoint.DisplayStats();
    Console.ReadLine();
}
```

The final `Point` variable is not making use of a custom constructor (as one might do traditionally) but is rather setting values to the public `X` and `Y` properties. Behind the scenes, the type's default constructor is invoked, followed by setting the values to the specified properties. To this end, object initialization syntax is just shorthand notation for the syntax used to create a class variable using a default constructor and to set the state data property by property.

Calling Custom Constructors with Initialization Syntax

The previous examples initialized `Point` types by implicitly calling the default constructor on the type.

```
// Here, the default constructor is called implicitly.
Point finalPoint = new Point { X = 30, Y = 30 };
```

If you want to be clear about this, it is permissible to explicitly call the default constructor as follows:

```
// Here, the default constructor is called explicitly.
Point finalPoint = new Point() { X = 30, Y = 30 };
```

Do be aware that when you are constructing a type using initialization syntax, you are able to invoke *any* constructor defined by the class. Our `Point` type currently defines a two-argument constructor to set the (x, y) position. Therefore, the following `Point` declaration results in an `X` value of 100 and a `Y` value of 100, regardless of the fact that the constructor arguments specified the values 10 and 16:

```
// Calling a custom constructor.
Point pt = new Point(10, 16) { X = 100, Y = 100 };
```

Given the current definition of your `Point` type, calling the custom constructor while using initialization syntax is not terribly useful (and more than a bit verbose). However, if your `Point` type provides a new constructor that allows the caller to establish a color (via a custom enum named `PointColor`), the combination of custom constructors and object initialization syntax becomes clear. Assume you have updated `Point` as follows:

```
enum PointColor
{ LightBlue, BloodRed, Gold }

class Point
{
    public int X { get; set; }
    public int Y { get; set; }
    public PointColor Color { get; set; }

    public Point(int xVal, int yVal)
    {
        X = xVal;
        Y = yVal;
        Color = PointColor.Gold;
    }

    public Point(PointColor ptColor)
    {
        Color = ptColor;
    }

    public Point()
        : this(PointColor.BloodRed){ }
}
```

```

public void DisplayStats()
{
    Console.WriteLine("[{0}, {1}]", X, Y);
    Console.WriteLine("Point is {0}", Color);
}
}

```

With this new constructor, you can now create a gold point (positioned at 90, 20) as follows:

```

// Calling a more interesting custom constructor with init syntax.
Point goldPoint = new Point(PointColor.Gold){ X = 90, Y = 20 };
goldPoint.DisplayStats();

```

Initializing Data with Initialization Syntax

As briefly mentioned earlier in this chapter (and fully examined in Chapter 6), the “has-a” relationship allows you to compose new classes by defining member variables of existing classes. For example, assume you now have a `Rectangle` class, which makes use of the `Point` type to represent its upper-left/bottom right coordinates. Since automatic properties set all fields of class variables to `null`, you will implement this new class using “traditional” property syntax.

```

class Rectangle
{
    private Point topLeft = new Point();
    private Point bottomRight = new Point();

    public Point TopLeft
    {
        get { return topLeft; }
        set { topLeft = value; }
    }
    public Point BottomRight
    {
        get { return bottomRight; }
        set { bottomRight = value; }
    }

    public void DisplayStats()
    {
        Console.WriteLine("[TopLeft: {0}, {1}, {2} BottomRight: {3}, {4}, {5}]",
            topLeft.X, topLeft.Y, topLeft.Color,
            bottomRight.X, bottomRight.Y, bottomRight.Color);
    }
}

```

Using object initialization syntax, you could create a new `Rectangle` variable and set the inner `Points` as follows:

```
// Create and initialize a Rectangle.
Rectangle myRect = new Rectangle
{
    TopLeft = new Point { X = 10, Y = 10 },
    BottomRight = new Point { X = 200, Y = 200 }
};
```

Again, the benefit of object initialization syntax is that it basically decreases the number of keystrokes (assuming there is not a suitable constructor). Here is the traditional approach to establishing a similar `Rectangle`:

```
// Old-school approach.
Rectangle r = new Rectangle();
Point p1 = new Point();
p1.X = 10;
p1.Y = 10;
r.TopLeft = p1;
Point p2 = new Point();
p2.X = 200;
p2.Y = 200;
r.BottomRight = p2;
```

While you might feel object initialization syntax can take a bit of getting used to, once you get comfortable with the code, you'll be quite pleased at how quickly you can establish the state of a new object with minimal fuss and bother.

■ **Source Code** The `ObjectInitializers` project can be found in the [Chapter 5](#) subdirectory.

Working with Constant Field Data

C# offers the `const` keyword to define constant data, which can never change after the initial assignment. As you might guess, this can be helpful when you are defining a set of known values for use in your applications that are logically connected to a given class or structure.

Assume you are building a utility class named `MyMathClass` that needs to define a value for the value `PI` (which you will assume to be 3.14 for simplicity). Begin by creating a new `Console Application` project named `ConstData`. Given that you would not want to allow other developers to change this value in code, `PI` could be modeled with the following constant:

```
namespace ConstData
{
    class MyMathClass
    {
        public const double PI = 3.14;
    }
}
```

```

class Program
{
    static void Main(string[] args)
    {
        Console.WriteLine("***** Fun with Const *****\n");
        Console.WriteLine("The value of PI is: {0}", MyMathClass.PI);
        // Error! Can't change a constant!
        // MyMathClass.PI = 3.1444;

        Console.ReadLine();
    }
}

```

Notice that you are referencing the constant data defined by `MyMathClass` using a class name prefix (i.e., `MyMathClass.PI`). This is because constant fields of a class are implicitly *static*. However, it is permissible to define and access a local constant variable within the scope of a method or property. Here's an example:

```

static void LocalConstStringVariable()
{
    // A local constant data point can be directly accessed.
    const string fixedStr = "Fixed string Data";
    Console.WriteLine(fixedStr);

    // Error!
    // fixedStr = "This will not work!";
}

```

Regardless of where you define a constant piece of data, the one point to always remember is that the initial value assigned to the constant must be specified at the time you define the constant. Thus, if you were to modify your `MyMathClass` in such a way that the value of `PI` is assigned in a class constructor as follows:

```

class MyMathClass
{
    // Try to set PI in ctor?
    public const double PI;

    public MyMathClass()
    {
        // Not possible- must assign at time of declaration.
        PI = 3.14;
    }
}

```

you would receive a compile-time error. The reason for this restriction has to do with the fact the value of constant data must be known at compile time. Constructors (or any other method), as you know, are invoked at runtime.

Understanding Read-Only Fields

Closely related to constant data is the notion of *read-only field data* (which should not be confused with a read-only property). Like a constant, a read-only field cannot be changed after the initial assignment. However, unlike a constant, the value assigned to a read-only field can be determined at runtime and, therefore, can legally be assigned within the scope of a constructor but nowhere else.

This can be helpful when you don't know the value of a field until runtime, perhaps because you need to read an external file to obtain the value, but want to ensure that the value will not change after that point. For the sake of illustration, assume the following update to `MyMathClass`:

```
class MyMathClass
{
    // Read-only fields can be assigned in ctors,
    // but nowhere else.
    public readonly double PI;

    public MyMathClass ()
    {
        PI = 3.14;
    }
}
```

Again, any attempt to make assignments to a field marked `readonly` outside the scope of a constructor results in a compiler error.

```
class MyMathClass
{
    public readonly double PI;
    public MyMathClass ()
    {
        PI = 3.14;
    }

    // Error!
    public void ChangePI()
    { PI = 3.14444;}
}
```

Static Read-Only Fields

Unlike a constant field, read-only fields are not implicitly static. Thus, if you want to expose `PI` from the class level, you must explicitly use the `static` keyword. If you know the value of a static read-only field at compile time, the initial assignment looks similar to that of a constant (however, in this case, it would be easier to simply use the `const` keyword in the first place, as you are assigning the data field at the time of declaration).

```

class MyMathClass
{
    public static readonly double PI = 3.14;
}

class Program
{
    static void Main(string[] args)
    {
        Console.WriteLine("***** Fun with Const *****");
        Console.WriteLine("The value of PI is: {0}", MyMathClass.PI);
        Console.ReadLine();
    }
}

```

However, if the value of a static read-only field is not known until runtime, you must use a static constructor as described earlier in this chapter.

```

class MyMathClass
{
    public static readonly double PI;

    static MyMathClass()
    { PI = 3.14; }
}

```

■ **Source Code** The ConstData project is included in the Chapter 5 subdirectory.

Understanding Partial Classes

Last but not least, it is important to understand the role of the C# `partial` keyword. A production-level class could easily consist of hundreds and hundreds (if not thousands) of lines of code within a single *.cs file. As it turns out, when you are creating your classes, it is often the case that much of the boilerplate code can be basically ignored after it is accounted for. For example, field data, properties, and constructors tend to remain as is during production, while methods tend to be modified quite often to account for updated algorithms and so forth.

In C#, you can partition a single class across multiple code files to isolate the boilerplate code from more readily useful (and complex) members. To illustrate where partial classes could be useful, open the EmployeeApp project you created previously in this chapter in Visual Studio, and then open the Employee.cs file for editing. As you recall, this single file contains code of all aspects of the class.

```

class Employee
{
    // Field Data

    // Constructors

    // Methods

    // Properties
}

```

Using partial classes, you could choose to move (for example) the properties, constructors, and field data into a new file named `Employee.Core.cs` (the name of the file is irrelevant). The first step is to add the `partial` keyword to the current class definition and cut the code to be placed into the new file.

```
// Employee.cs
partial class Employee
{
    // Methods

    // Properties
}
```

Next, assuming you have inserted a new class file into your project, you can move the data fields and constructors to the new file using a simple cut/paste operation. In addition, you *must* add the `partial` keyword to this aspect of the class definition. Here's an example:

```
// Employee.Core.cs
partial class Employee
{
    // Field data

    // Constructors
}
```

■ **Note** Remember that every aspect of a partial class definition must be marked with the `partial` keyword!

After you compile the modified project, you should see no difference whatsoever. The whole idea of a partial class is realized only during design time. After the application has been compiled, there is just a single, unified class within the assembly. The only requirement when defining partial types is that the type's name (`Employee` in this case) is identical and defined within the same .NET namespace.

Use Cases for Partial Classes?

Now that you understand the mechanics of how to define a partial class, you may be wondering exactly when (and if) you will ever need to do so. To be honest, you may not need to make use of partial class definitions too often. However, Visual Studio uses them in the background all the time. For example, if you are building a graphical user interface using Windows Presentation Foundation (WPF), you will note that Visual Studio places all the designer-generated code into a dedicated partial class file, leaving you to focus on your custom programming logic (without the designer generated code getting in the way).

■ **Source Code** The `EmployeeAppPartial` project can be found in the [Chapter 5](#) subdirectory.

Summary

The point of this chapter was to introduce you to the role of the C# class type. As you have seen, classes can take any number of *constructors* that enable the object user to establish the state of the object upon creation. This chapter also illustrated several class design techniques (and related keywords). Recall that the `this` keyword can be used to obtain access to the current object, the `static` keyword allows you to define fields and members that are bound at the class (not object) level, and the `const` keyword (and `readonly` modifier) allows you to define a point of data that can never change after the initial assignment.

The bulk of this chapter dug into the details of the first pillar of OOP: encapsulation. You learned about the access modifiers of C# and the role of type properties, object initialization syntax, and partial classes. With this behind you, you are now able to turn to the next chapter where you will learn to build a family of related classes using inheritance and polymorphism.

CHAPTER 6



Understanding Inheritance and Polymorphism

Chapter 5 examined the first pillar of OOP: encapsulation. At that time, you learned how to build a single well-defined class type with constructors and various members (fields, properties, methods, constants, and read-only fields). This chapter will focus on the remaining two pillars of OOP: inheritance and polymorphism.

First, you will learn how to build families of related classes using *inheritance*. As you will see, this form of code reuse allows you to define common functionality in a parent class that can be leveraged, and possibly altered, by child classes. Along the way, you will learn how to establish a *polymorphic interface* into class hierarchies using virtual and abstract members, as well as the role of explicit casting.

The chapter will wrap up by examining the role of the ultimate parent class in the .NET base class libraries: `System.Object`.

The Basic Mechanics of Inheritance

Recall from Chapter 5 that inheritance is an aspect of OOP that facilitates code reuse. Specifically speaking, code reuse comes in two flavors: inheritance (the “is-a” relationship) and the containment/delegation model (the “has-a” relationship). Let’s begin this chapter by examining the classical inheritance model of the “is-a” relationship.

When you establish “is-a” relationships between classes, you are building a dependency between two or more class types. The basic idea behind classical inheritance is that new classes can be created using existing classes as a starting point. To begin with a simple example, create a new Console Application project named Basic Inheritance. Now assume you have designed a class named `Car` that models some basic details of an automobile.

```
// A simple base class.
class Car
{
    public readonly int maxSpeed;
    private int currSpeed;

    public Car(int max)
    {
        maxSpeed = max;
    }
}
```

```

public Car()
{
    maxSpeed = 55;
}
public int Speed
{
    get { return currSpeed; }
    set
    {
        currSpeed = value;
        if (currSpeed > maxSpeed)
        {
            currSpeed = maxSpeed;
        }
    }
}
}

```

Notice that the Car class is using encapsulation services to control access to the private `currSpeed` field using a public property named `Speed`. At this point, you can exercise your Car type as follows:

```

static void Main(string[] args)
{
    Console.WriteLine("***** Basic Inheritance *****\n");
    // Make a Car object and set max speed.
    Car myCar = new Car(80);

    // Set the current speed, and print it.
    myCar.Speed = 50;
    Console.WriteLine("My car is going {0} MPH", myCar.Speed);
    Console.ReadLine();
}

```

Specifying the Parent Class of an Existing Class

Now assume you want to build a new class named `MiniVan`. Like a basic Car, you want to define the `MiniVan` class to support data for a maximum speed, a current speed, and a property named `Speed` to allow the object user to modify the object's state. Clearly, the Car and `MiniVan` classes are related; in fact, it can be said that a `MiniVan` “is-a” type of Car. The “is-a” relationship (formally termed *classical inheritance*) allows you to build new class definitions that extend the functionality of an existing class.

The existing class that will serve as the basis for the new class is termed a *base class*, *superclass*, or *parent class*. The role of a base class is to define all the common data and members for the classes that extend it. The extending classes are formally termed *derived* or *child* classes. In C#, you make use of the colon operator on the class definition to establish an “is-a” relationship between classes. Assume you have authored the following new `MiniVan` class:

```

// MiniVan "is-a" Car.
class MiniVan : Car
{
}

```

Currently, this new class has not defined any members whatsoever. So, what have you gained by extending your `MiniVan` from the `Car` base class? Simply put, `MiniVan` objects now have access to each public member defined within the parent class.

■ **Note** Although constructors are typically defined as public, a derived class never inherits the constructors of a parent class. Constructors are used to construct only the class that they are defined within.

Given the relation between these two class types, you could now make use of the `MiniVan` class like so:

```
static void Main(string[] args)
{
    Console.WriteLine("***** Basic Inheritance *****\n");
    ...
    // Now make a MiniVan object.
    MiniVan myVan = new MiniVan();
    myVan.Speed = 10;
    Console.WriteLine("My van is going {0} MPH",
        myVan.Speed);
    Console.ReadLine();
}
```

Again, notice that although you have not added any members to the `MiniVan` class, you have direct access to the public `Speed` property of your parent class and have thus reused code. This is a far better approach than creating a `MiniVan` class that has the same members as `Car`, such as a `Speed` property. If you did duplicate code between these two classes, you would need to now maintain two bodies of code, which is certainly a poor use of your time.

Always remember that inheritance preserves encapsulation; therefore, the following code results in a compiler error, as private members can never be accessed from an object reference:

```
static void Main(string[] args)
{
    Console.WriteLine("***** Basic Inheritance *****\n");
    ...
    // Make a MiniVan object.
    MiniVan myVan = new MiniVan();
    myVan.Speed = 10;
    Console.WriteLine("My van is going {0} MPH",
        myVan.Speed);

    // Error! Can't access private members!
    myVan.currSpeed = 55;
    Console.ReadLine();
}
```

On a related note, if the `MiniVan` defined its own set of members, it would still not be able to access any private member of the `Car` base class. Remember, private members can be accessed *only* by the class that defines it. For example, the following method in `MiniVan` would result in a compiler error:

```
// MiniVan derives from Car.
class MiniVan : Car
{
    public void TestMethod()
    {
        // OK! Can access public members
        // of a parent within a derived type.
        Speed = 10;

        // Error! Cannot access private
        // members of parent within a derived type.
        currSpeed = 10;
    }
}
```

Regarding Multiple Base Classes

Speaking of base classes, it is important to keep in mind that *C#* demands that a given class have exactly *one* direct base class. It is not possible to create a class type that directly derives from two or more base classes (this technique, which is supported in unmanaged C++, is known as *multiple inheritance*, or simply *MI*). If you attempted to create a class that specifies two direct parent classes, as shown in the following code, you would receive compiler errors:

```
// Illegal! C# does not allow
// multiple inheritance for classes!
class WontWork
    : BaseClassOne, BaseClassTwo
{ }
```

As you will see in Chapter 8, the .NET platform does allow a given class, or structure, to implement any number of discrete interfaces. In this way, a *C#* type can exhibit a number of behaviors while avoiding the complexities associated with MI. On a related note, while a class can have only one direct base class, it is permissible for an interface to directly derive from multiple interfaces. Using this technique, you can build sophisticated interface hierarchies that model complex behaviors (again, see Chapter 8).

The sealed Keyword

C# supplies another keyword, `sealed`, that prevents inheritance from occurring. When you mark a class as `sealed`, the compiler will not allow you to derive from this type. For example, assume you have decided that it makes no sense to further extend the `MiniVan` class.

```
// The MiniVan class cannot be extended!
sealed class MiniVan : Car
{
}
```

If you (or a teammate) were to attempt to derive from this class, you would receive a compile-time error.

```
// Error! Cannot extend
// a class marked with the sealed keyword!
class DeluxeMiniVan
    : MiniVan
{}
```

Most often, sealing a class makes the best sense when you are designing a utility class. For example, the `System` namespace defines numerous sealed classes. You can verify this for yourself by opening the Visual Studio Object Browser (via the View menu) and selecting the `String` class within the `System` namespace of the `mcorlib.dll` assembly. Notice in Figure 6-1 the icon used to denote a sealed class.

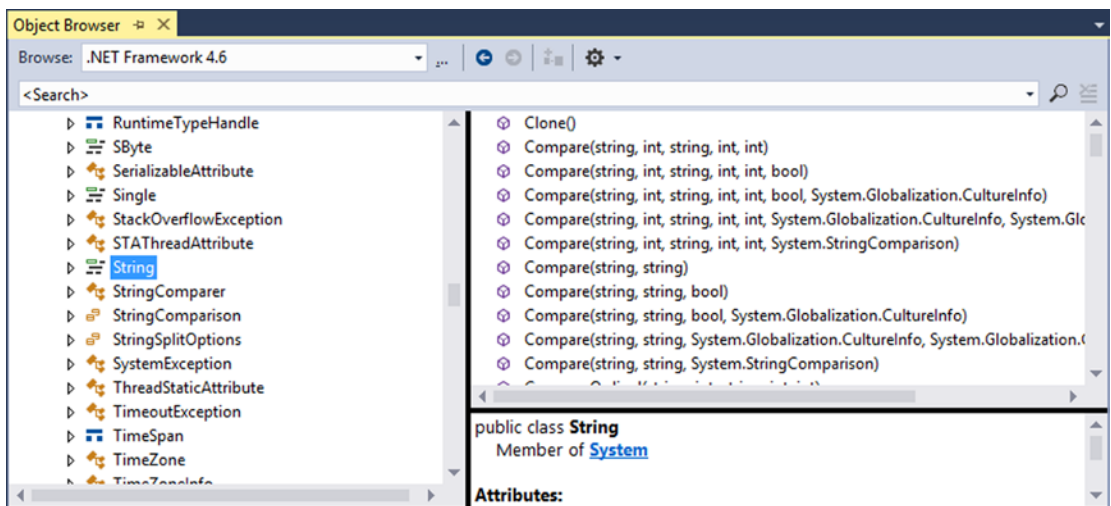

Figure 6-1. The base class libraries define numerous sealed types, such as `System.String`

Thus, just like the `MiniVan`, if you attempt to build a new class that extends `System.String`, you will receive a compile-time error.

```
// Another error! Cannot extend
// a class marked as sealed!
class MyString
    : String
{}
```

■ **Note** In Chapter 4, you learned that C# structures are always implicitly sealed (see Table 4-3). Therefore, you can never derive one structure from another structure, a class from a structure, or a structure from a class. Structures can be used to model only stand-alone, atomic, user-defined data types. If you want to leverage the is-a relationship, you must use classes.

As you would guess, there are many more details to inheritance that you will come to know during the remainder of this chapter. For now, simply keep in mind that the colon operator allows you to establish base/derived class relationships, while the sealed keyword prevents subsequent inheritance from occurring.

Revising Visual Studio Class Diagrams

In Chapter 2, I briefly mentioned that Visual Studio allows you to establish base/derived class relationships visually at design time. To leverage this aspect of the IDE, your first step is to include a new class diagram file into your current project. To do so, access the Project ► Add New Item menu option and click the Class Diagram icon (in Figure 6-2, I renamed the file from ClassDiagram1.cd to Cars.cd).

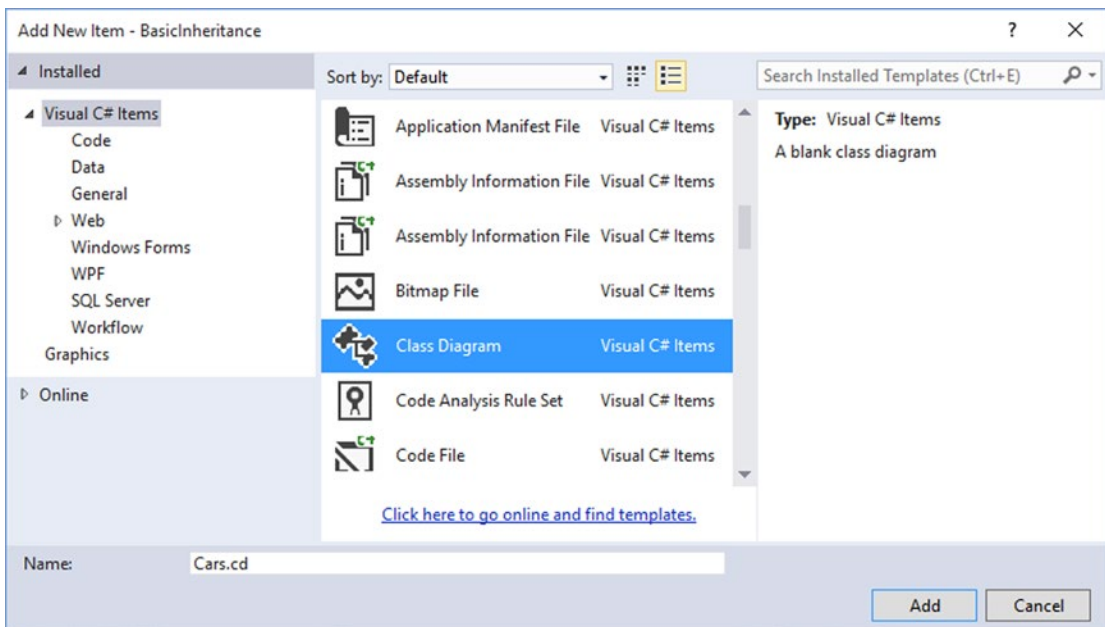

Figure 6-2. Inserting a new class diagram

After you click the Add button, you will be presented with a blank designer surface. To add types to a class designer, simply drag each file from the Solution Explorer window onto the surface. Also recall that if you delete an item from the visual designer (simply by selecting it and pressing the Delete key), this will not destroy the associated source code but simply remove the item off the designer surface. Figure 6-3 shows the current class hierarchy.

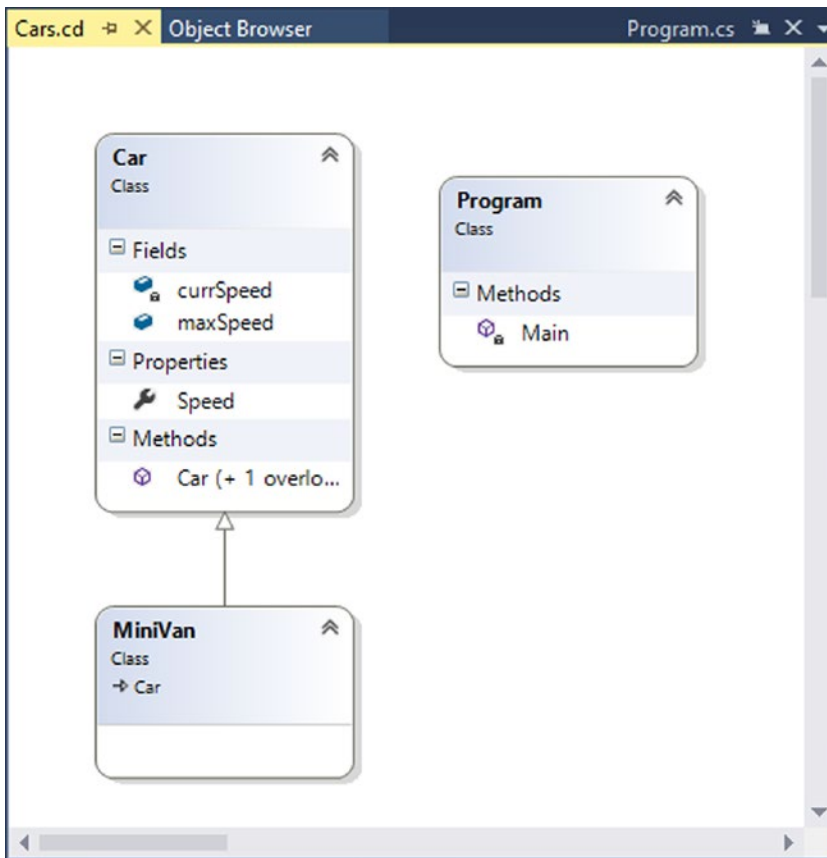

Figure 6-3. The visual designer of Visual Studio

Beyond simply displaying the relationships of the types within your current application, recall from Chapter 2 that you can also create new types and populate their members using the Class Designer toolbox and Class Details window.

If you want to make use of these visual tools during the remainder of the book, feel free. However, always make sure you analyze the generated code so you have a solid understanding of what these tools have done on your behalf.

■ **Source Code** The Basic Inheritance project is located in the Chapter 6 subdirectory.

The Second Pillar of OOP: The Details of Inheritance

Now that you have seen the basic syntax of inheritance, let's create a more complex example and get to know the numerous details of building class hierarchies. To do so, you will be reusing the `Employee` class you designed in Chapter 5. To begin, create a new C# Console Application project named `Employees`.

Next, activate the Project ► Add Existing Item menu option and navigate to the location of your `Employee.cs` and `Employee.Core.cs` files you created in the `EmployeeApp` example of Chapter 5. Select each of them (via a Ctrl+click) and click the Add button. Visual Studio responds by copying each file into the current project (because these are full copies, you will not need to worry about changing the original work you did in the Chapter 5 project).

Before you start to build some derived classes, you have one detail to attend to. Because the original `Employee` class was created in a project named `EmployeeApp`, the class has been wrapped within an identically named `.NET` namespace. Chapter 14 will examine namespaces in detail; however, for simplicity, rename the current namespace (in both file locations) to `Employees` to match your new project name.

```
// Be sure to change the namespace name in both C# files!
namespace Employees
{
    partial class Employee
    {...}
}
```

■ **Note** As a sanity check, compile and run your new project by pressing Ctrl+F5. The program will not do anything at this point; however, this will ensure you do not have any compiler errors.

Your goal is to create a family of classes that model various types of employees in a company. Assume you want to leverage the functionality of the `Employee` class to create two new classes (`SalesPerson` and `Manager`). The new `SalesPerson` class “is-an” `Employee` (as is a `Manager`). Remember that under the classical inheritance model, base classes (such as `Employee`) are used to define general characteristics that are common to all descendants. Subclasses (such as `SalesPerson` and `Manager`) extend this general functionality while adding more specific functionality.

For your example, you will assume that the `Manager` class extends `Employee` by recording the number of stock options, while the `SalesPerson` class maintains the number of sales made. Insert a new class file (`Manager.cs`) that defines the `Manager` class with the following automatic property:

```
// Managers need to know their number of stock options.
class Manager : Employee
{
    public int StockOptions { get; set; }
}
```

Next, add another new class file (`SalesPerson.cs`) that defines the `SalesPerson` class with a fitting automatic property.

```
// Salespeople need to know their number of sales.
class SalesPerson : Employee
{
    public int SalesNumber { get; set; }
}
```

Now that you have established an “is-a” relationship, `SalesPerson` and `Manager` have automatically inherited all public members of the `Employee` base class. To illustrate, update your `Main()` method as follows:

```
// Create a subclass object and access base class functionality.
static void Main(string[] args)
{
    Console.WriteLine("***** The Employee Class Hierarchy *****\n");
    SalesPerson fred = new SalesPerson();
    fred.Age = 31;
    fred.Name = "Fred";
    fred.SalesNumber = 50;
    Console.ReadLine();
}
```

Controlling Base Class Creation with the `base` Keyword

Currently, `SalesPerson` and `Manager` can be created only using the “freebie” default constructor (see Chapter 5). With this in mind, assume you have added a new six-argument constructor to the `Manager` type, which is invoked as follows:

```
static void Main(string[] args)
{
    ...
    // Assume Manager has a constructor matching this signature:
    // (string fullName, int age, int empID,
    // float currPay, string ssn, int numbofOpts)
    Manager chucky = new Manager("Chucky", 50, 92, 100000, "333-23-2322", 9000);
    Console.ReadLine();
}
```

If you look at the parameter list, you can clearly see that most of these arguments should be stored in the member variables defined by the `Employee` base class. To do so, you might implement this custom constructor on the `Manager` class as follows:

```
public Manager(string fullName, int age, int empID,
               float currPay, string ssn, int numbofOpts)
{
    // This property is defined by the Manager class.
    StockOptions = numbofOpts;

    // Assign incoming parameters using the
    // inherited properties of the parent class.
    ID = empID;
    Age = age;
    Name = fullName;
    Pay = currPay;

    // OOPS! This would be a compiler error,
    // if the SSN property were read-only!
    SocialSecurityNumber = ssn;
}
```

The first issue with this approach is that if you defined any property as read-only (for example, the `SocialSecurityNumber` property), you are unable to assign the incoming `string` parameter to this field, as shown in the final code statement of this custom constructor.

The second issue is that you have indirectly created a rather inefficient constructor, given that under *C#*, unless you say otherwise, the default constructor of a base class is called automatically before the logic of the derived constructor is executed. After this point, the current implementation accesses numerous public properties of the `Employee` base class to establish its state. Thus, you have really made seven hits (five inherited properties and two constructor calls) during the creation of a `Manager` object!

To help optimize the creation of a derived class, you will do well to implement your subclass constructors to explicitly call an appropriate custom base class constructor, rather than the default. In this way, you are able to reduce the number of calls to inherited initialization members (which saves processing time). First, ensure your `Employee` parent class has the following five-argument constructor:

```
// Add to the Employee base class.
public Employee(string name, int age, int id, float pay, string ssn)
    :this(name, age, id, pay)
{
    empSSN = ssn;
}
```

Now, let's retrofit the custom constructor of the `Manager` type to do this very thing using the `base` keyword.

```
public Manager(string fullName, int age, int empID,
               float currPay, string ssn, int numbofOpts)
    : base(fullName, age, empID, currPay, ssn)
{
    // This property is defined by the Manager class.
    StockOptions = numbofOpts;
}
```

Here, the `base` keyword is hanging off the constructor signature (much like the syntax used to chain constructors on a single class using the `this` keyword, as was discussed in Chapter 5), which always indicates a derived constructor is passing data to the immediate parent constructor. In this situation, you are explicitly calling the five-parameter constructor defined by `Employee` and saving yourself unnecessary calls during the creation of the child class. The custom `SalesPerson` constructor looks almost identical.

```
// As a general rule, all subclasses should explicitly call an appropriate
// base class constructor.
public SalesPerson(string fullName, int age, int empID,
                  float currPay, string ssn, int numbofSales)
    : base(fullName, age, empID, currPay, ssn)
{
    // This belongs with us!
    SalesNumber = numbofSales;
}
```

■ **Note** You may use the `base` keyword whenever a subclass wants to access a public or protected member defined by a parent class. Use of this keyword is not limited to constructor logic. You will see examples using `base` in this manner during the examination of polymorphism, later in this chapter.

Finally, recall that once you add a custom constructor to a class definition, the default constructor is silently removed. Therefore, be sure to redefine the default constructor for the `SalesPerson` and `Manager` types. Here's an example:

```
// Add back the default ctor
// in the Manager class as well.
public SalesPerson() {}
```

Keeping Family Secrets: The protected Keyword

As you already know, public items are directly accessible from anywhere, while private items can be accessed only by the class that has defined them. Recall from Chapter 5 that C# takes the lead of many other modern object languages and provides an additional keyword to define member accessibility: `protected`.

When a base class defines protected data or protected members, it establishes a set of items that can be accessed directly by any descendant. If you want to allow the `SalesPerson` and `Manager` child classes to directly access the data sector defined by `Employee`, you can update the original `Employee` class definition as follows:

```
// Protected state data.
partial class Employee
{
    // Derived classes can now directly access this information.
    protected string empName;
    protected int empID;
    protected float currPay;
    protected int empAge;
    protected string empSSN;
    ...
}
```

The benefit of defining protected members in a base class is that derived types no longer have to access the data indirectly using public methods or properties. The possible downfall, of course, is that when a derived type has direct access to its parent's internal data, it is possible to accidentally bypass existing business rules found within public properties. When you define protected members, you are creating a level of trust between the parent class and the child class, as the compiler will not catch any violation of your type's business rules.

Finally, understand that as far as the object user is concerned, protected data is regarded as private (as the user is "outside" the family). Therefore, the following is illegal:

```
static void Main(string[] args)
{
    // Error! Can't access protected data from client code.
    Employee emp = new Employee();
    emp.empName = "Fred";
}
```

■ **Note** Although protected field data can break encapsulation, it is quite safe (and useful) to define protected methods. When building class hierarchies, it is common to define a set of methods that are only for use by derived types and are not intended for use by the outside world.

Adding a Sealed Class

Recall that a *sealed* class cannot be extended by other classes. As mentioned, this technique is most often used when you are designing a utility class. However, when building class hierarchies, you might find that a certain branch in the inheritance chain should be “capped off,” as it makes no sense to further extend the lineage. For example, assume you have added yet another class to your program (PTSalesPerson) that extends the existing SalesPerson type. Figure 6-4 shows the current update.

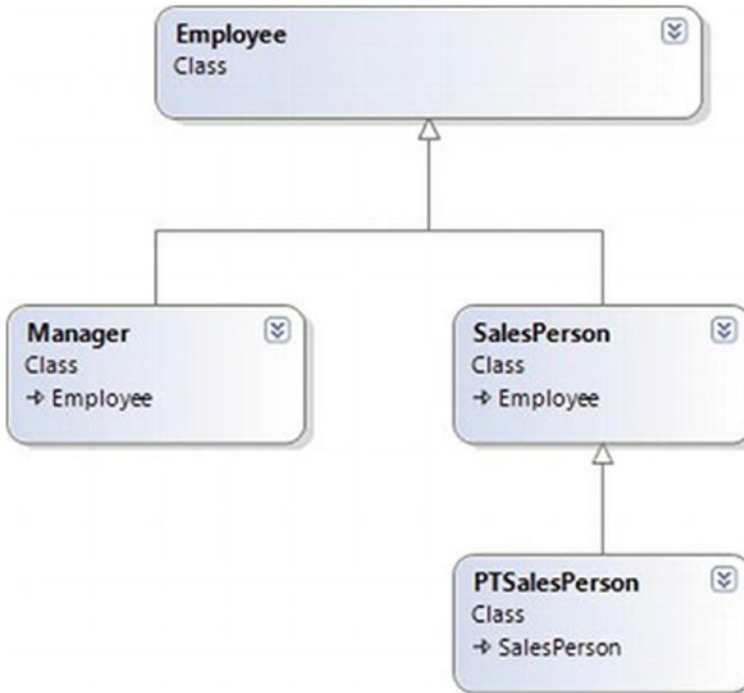

Figure 6-4. The PTSalesPerson class

PTSalesPerson is a class representing, of course, a part-time salesperson. For the sake of argument, let’s say you want to ensure that no other developer is able to subclass from PTSalesPerson. (After all, how much more part-time can you get than “part-time”?) Again, to prevent others from extending a class, use the sealed keyword.

```
sealed class PTSalesPerson : SalesPerson
{
    public PTSalesPerson(string fullName, int age, int empID,
                        float currPay, string ssn, int numbofSales)
        :base (fullName, age, empID, currPay, ssn, numbofSales)
    {
    }
    // Assume other members here...
}
```

Programming for Containment/Delegation

Recall that code reuse comes in two flavors. You have just explored the classical “is-a” relationship. Before you examine the third pillar of OOP (polymorphism), let’s examine the “has-a” relationship (also known as the *containment/delegation model* or *aggregation*). Assume you have created a new class that models an employee benefits package, as follows:

```
// This new type will function as a contained class.
class BenefitPackage
{
    // Assume we have other members that represent
    // dental/health benefits, and so on.
    public double ComputePayDeduction()
    {
        return 125.0;
    }
}
```

Obviously, it would be rather odd to establish an “is-a” relationship between the `BenefitPackage` class and the employee types. (Employee “is-a” `BenefitPackage`? I don’t think so.) However, it should be clear that some sort of relationship between the two could be established. In short, you would like to express the idea that each employee “has-a” `BenefitPackage`. To do so, you can update the `Employee` class definition as follows:

```
// Employees now have benefits.
partial class Employee
{
    // Contain a BenefitPackage object.
    protected BenefitPackage empBenefits = new BenefitPackage();
    ...
}
```

At this point, you have successfully contained another object. However, exposing the functionality of the contained object to the outside world requires delegation. *Delegation* is simply the act of adding public members to the containing class that use the contained object’s functionality.

For example, you could update the `Employee` class to expose the contained `empBenefits` object using a custom property, as well as make use of its functionality internally using a new method named `GetBenefitCost()`.

```
partial class Employee
{
    // Contain a BenefitPackage object.
    protected BenefitPackage empBenefits = new BenefitPackage();

    // Expose certain benefit behaviors of object.
    public double GetBenefitCost()
    { return empBenefits.ComputePayDeduction(); }
}
```



```
// Expose object through a custom property.
public BenefitPackage Benefits
{
    get { return empBenefits; }
    set { empBenefits = value; }
}
...
}
```

In the following updated `Main()` method, notice how you can interact with the internal `BenefitsPackage` type defined by the `Employee` type.

```
static void Main(string[] args)
{
    Console.WriteLine("***** The Employee Class Hierarchy *****\n");
    ...
    Manager chucky = new Manager("Chucky", 50, 92, 100000, "333-23-2322", 9000);
    double cost = chucky.GetBenefitCost();
    Console.ReadLine();
}
```

Understanding Nested Type Definitions

Chapter 5 briefly mentioned the concept of nested types, which is a spin on the “has-a” relationship you have just examined. In C# (as well as other .NET languages), it is possible to define a type (enum, class, interface, struct, or delegate) directly within the scope of a class or structure. When you have done so, the nested (or “inner”) type is considered a member of the nesting (or “outer”) class and in the eyes of the runtime can be manipulated like any other member (fields, properties, methods, and events). The syntax used to nest a type is quite straightforward.

```
public class OuterClass
{
    // A public nested type can be used by anybody.
    public class PublicInnerClass {}

    // A private nested type can only be used by members
    // of the containing class.
    private class PrivateInnerClass {}
}
```

Although the syntax is fairly clear, understanding why you would want to do this might not be readily apparent. To understand this technique, ponder the following traits of nesting a type:

- Nested types allow you to gain complete control over the access level of the inner type because they may be declared privately (recall that non-nested classes cannot be declared using the `private` keyword).
- Because a nested type is a member of the containing class, it can access private members of the containing class.
- Often, a nested type is useful only as a helper for the outer class and is not intended for use by the outside world.

When a type nests another class type, it can create member variables of the type, just as it would for any point of data. However, if you want to use a nested type from outside the containing type, you must qualify it by the scope of the nesting type. Consider the following code:

```
static void Main(string[] args)
{
    // Create and use the public inner class. OK!
    OuterClass.PublicInnerClass inner;
    inner = new OuterClass.PublicInnerClass();

    // Compiler Error! Cannot access the private class.
    OuterClass.PrivateInnerClass inner2;
    inner2 = new OuterClass.PrivateInnerClass();
}
```

To use this concept within the employees example, assume you have now nested the `BenefitPackage` directly within the `Employee` class type.

```
partial class Employee
{
    public class BenefitPackage
    {
        // Assume we have other members that represent
        // dental/health benefits, and so on.
        public double ComputePayDeduction()
        {
            return 125.0;
        }
    }
    ...
}
```

The nesting process can be as “deep” as you require. For example, assume you want to create an enumeration named `BenefitPackageLevel`, which documents the various benefit levels an employee may choose. To programmatically enforce the tight connection between `Employee`, `BenefitPackage`, and `BenefitPackageLevel`, you could nest the enumeration as follows:

```
// Employee nests BenefitPackage.
public partial class Employee
{
    // BenefitPackage nests BenefitPackageLevel.
    public class BenefitPackage
    {
        public enum BenefitPackageLevel
        {
            Standard, Gold, Platinum
        }
    }
}
```

```

    public double ComputePayDeduction()
    {
        return 125.0;
    }
}
...
}

```

Because of the nesting relationships, note how you are required to make use of this enumeration:

```

static void Main(string[] args)
{
    ...
    // Define my benefit level.
    Employee.BenefitPackage.BenefitPackageLevel myBenefitLevel =
        Employee.BenefitPackage.BenefitPackageLevel.Platinum;
    Console.ReadLine();
}

```

Excellent! At this point, you have been exposed to a number of keywords (and concepts) that allow you to build hierarchies of related types via classical inheritance, containment, and nested types. If the details aren't crystal clear right now, don't sweat it. You will be building a number of additional hierarchies over the remainder of this book. Next up, let's examine the final pillar of OOP: polymorphism.

The Third Pillar of OOP: C#'s Polymorphic Support

Recall that the `Employee` base class defined a method named `GiveBonus()`, which was originally implemented as follows:

```

public partial class Employee
{
    public void GiveBonus(float amount)
    {
        Pay += amount;
    }
}
...
}

```

Because this method has been defined with the `public` keyword, you can now give bonuses to salespeople and managers (as well as part-time salespeople).

```

static void Main(string[] args)
{
    Console.WriteLine("***** The Employee Class Hierarchy *****\n");

    // Give each employee a bonus?
    Manager chucky = new Manager("Chucky", 50, 92, 100000, "333-23-2322", 9000);
    chucky.GiveBonus(300);
    chucky.DisplayStats();
    Console.WriteLine();
}

```

```

SalesPerson fran = new SalesPerson("Fran", 43, 93, 3000, "932-32-3232", 31);
fran.GiveBonus(200);
fran.DisplayStats();
Console.ReadLine();
}

```

The problem with the current design is that the publicly inherited `GiveBonus()` method operates identically for all subclasses. Ideally, the bonus of a salesperson or part-time salesperson should take into account the number of sales. Perhaps managers should gain additional stock options in conjunction with a monetary bump in salary. Given this, you are suddenly faced with an interesting question: “How can related types respond differently to the same request?” Again, glad you asked!

The virtual and override Keywords

Polymorphism provides a way for a subclass to define its own version of a method defined by its base class, using the process termed *method overriding*. To retrofit your current design, you need to understand the meaning of the `virtual` and `override` keywords. If a base class wants to define a method that *may be* (but does not have to be) overridden by a subclass, it must mark the method with the `virtual` keyword.

```

partial class Employee
{
    // This method can now be "overridden" by a derived class.
    public virtual void GiveBonus(float amount)
    {
        Pay += amount;
    }
    ...
}

```

■ **Note** Methods that have been marked with the `virtual` keyword are (not surprisingly) termed *virtual methods*.

When a subclass wants to change the implementation details of a virtual method, it does so using the `override` keyword. For example, the `SalesPerson` and `Manager` could override `GiveBonus()` as follows (assume that `PTSalesPerson` will not override `GiveBonus()` and, therefore, simply inherits the version defined by `SalesPerson`):

```

class SalesPerson : Employee
{
    ...
    // A salesperson's bonus is influenced by the number of sales.
    public override void GiveBonus(float amount)
    {
        int salesBonus = 0;
        if (SalesNumber >= 0 && SalesNumber <= 100)
            salesBonus = 10;
    }
}

```

```

    else
    {
        if (SalesNumber >= 101 && SalesNumber <= 200)
            salesBonus = 15;
        else
            salesBonus = 20;
    }
    base.GiveBonus(amount * salesBonus);
}
}

class Manager : Employee
{
    ...
    public override void GiveBonus(float amount)
    {
        base.GiveBonus(amount);
        Random r = new Random();
        StockOptions += r.Next(500);
    }
}

```

Notice how each overridden method is free to leverage the default behavior using the base keyword.

In this way, you have no need to completely reimplement the logic behind GiveBonus() but can reuse (and possibly extend) the default behavior of the parent class.

Also assume that the current DisplayStats() method of the Employee class has been declared virtually.

```

public virtual void DisplayStats()
{
    Console.WriteLine("Name: {0}", Name);
    Console.WriteLine("ID: {0}", ID);
    Console.WriteLine("Age: {0}", Age);
    Console.WriteLine("Pay: {0}", Pay);
    Console.WriteLine("SSN: {0}", SocialSecurityNumber);
}

```

By doing so, each subclass can override this method to account for displaying the number of sales (for salespeople) and current stock options (for managers). For example, consider the Manager's version of the DisplayStats() method (the SalesPerson class would implement DisplayStats() in a similar manner to show the number of sales).

```

public override void DisplayStats()
{
    base.DisplayStats();
    Console.WriteLine("Number of Stock Options: {0}", StockOptions);
}

```

Now that each subclass can interpret what these virtual methods mean for itself, each object instance behaves as a more independent entity.

```
static void Main(string[] args)
{
    Console.WriteLine("***** The Employee Class Hierarchy *****\n");

    // A better bonus system!
    Manager chucky = new Manager("Chucky", 50, 92, 100000, "333-23-2322", 9000);
    chucky.GiveBonus(300);
    chucky.DisplayStats();
    Console.WriteLine();

    SalesPerson fran = new SalesPerson("Fran", 43, 93, 3000, "932-32-3232", 31);
    fran.GiveBonus(200);
    fran.DisplayStats();
    Console.ReadLine();
}
```

The following output shows a possible test run of your application thus far:

```
***** The Employee Class Hierarchy *****

Name: Chucky
ID: 92
Age: 50
Pay: 100300
SSN: 333-23-2322
Number of Stock Options: 9337

Name: Fran
ID: 93
Age: 43
Pay: 5000
SSN: 932-32-3232
Number of Sales: 31
```

Overriding Virtual Members Using the Visual Studio IDE

As you might have already noticed, when you are overriding a member, you must recall the type of every parameter—not to mention the method name and parameter passing conventions (*ref*, *out*, and *params*). Visual Studio has a helpful feature that you can make use of when overriding a virtual member. If you type the word *override* within the scope of a class type (then hit the spacebar), IntelliSense will automatically display a list of all the overridable members defined in your parent classes, as you see in Figure 6-5.

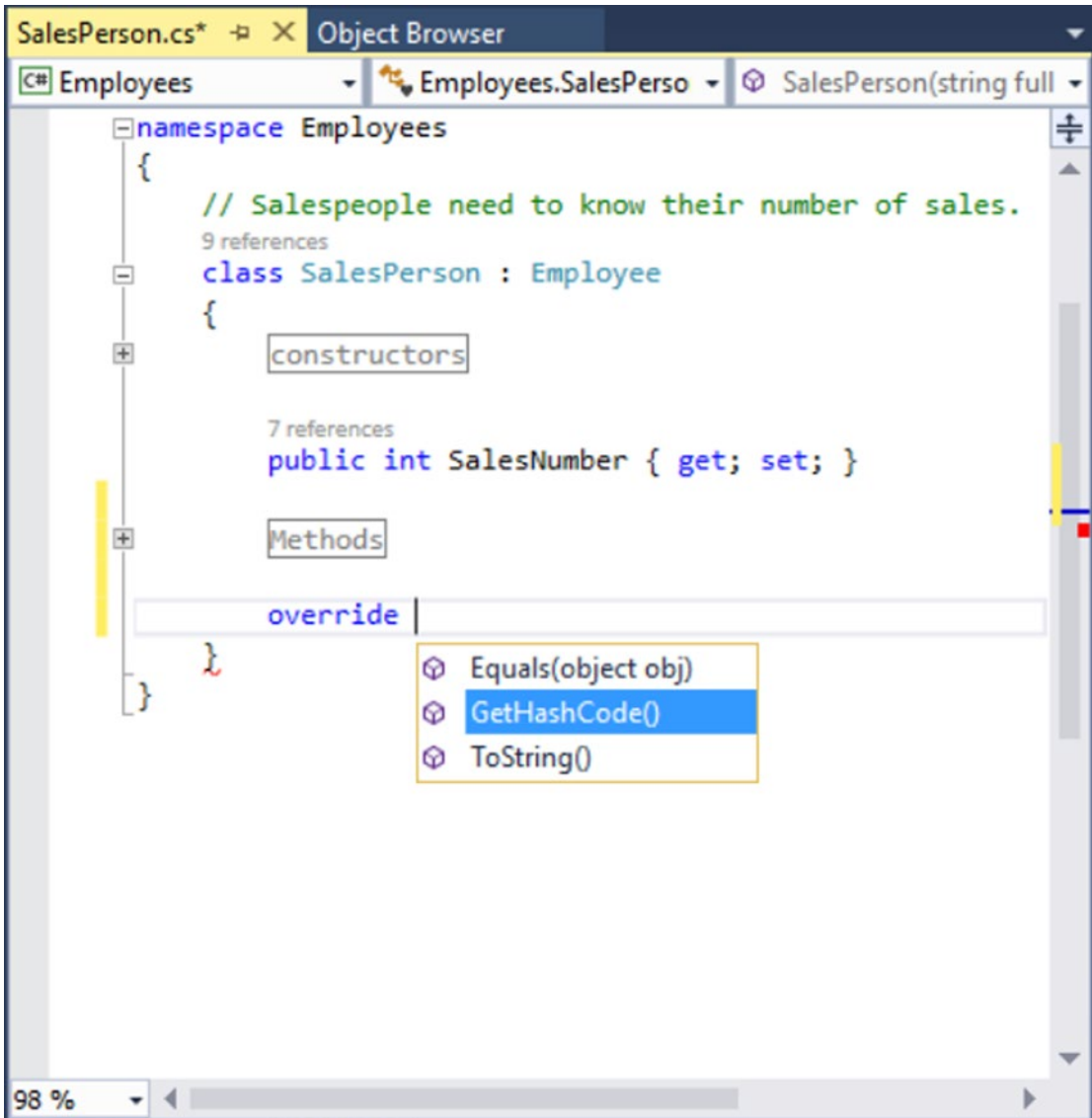

Figure 6-5. Quickly viewing overridable methods à la Visual Studio

When you select a member and hit the Enter key, the IDE responds by automatically filling in the method stub on your behalf. Note that you also receive a code statement that calls your parent’s version of the virtual member (you are free to delete this line if it is not required). For example, if you used this technique when overriding the `DisplayStats()` method, you might find the following autogenerated code:

```

public override void DisplayStats()
{
    base.DisplayStats();
}
    
```

Sealing Virtual Members

Recall that the sealed keyword can be applied to a class type to prevent other types from extending its behavior via inheritance. As you might remember, you sealed `PTSalesPerson` because you assumed it made no sense for other developers to extend this line of inheritance any further.

On a related note, sometimes you might not want to seal an entire class but simply want to prevent derived types from overriding particular virtual methods. For example, assume you do not want part-time salespeople to obtain customized bonuses. To prevent the `PTSalesPerson` class from overriding the virtual `GiveBonus()` method, you could effectively seal this method in the `SalesPerson` class as follows:

```
// SalesPerson has sealed the GiveBonus() method!
class SalesPerson : Employee
{
    ...
    public override sealed void GiveBonus(float amount)
    {
        ...
    }
}
```

Here, `SalesPerson` has indeed overridden the virtual `GiveBonus()` method defined in the `Employee` class; however, it has explicitly marked it as sealed. Thus, if you attempted to override this method in the `PTSalesPerson` class, you would receive compile-time errors, as shown in the following code:

```
sealed class PTSalesPerson : SalesPerson
{
    public PTSalesPerson(string fullName, int age, int empID,
        float currPay, string ssn, int numbofSales)
        :base (fullName, age, empID, currPay, ssn, numbofSales)
    {
    }

    // Compiler error! Can't override this method
    // in the PTSalesPerson class, as it was sealed.
    public override void GiveBonus(float amount)
    {
    }
}
```

Understanding Abstract Classes

Currently, the `Employee` base class has been designed to supply various data members for its descendants, as well as supply two virtual methods (`GiveBonus()` and `DisplayStats()`) that may be overridden by a given descendant. While this is all well and good, there is a rather odd byproduct of the current design; you can directly create instances of the `Employee` base class.

```
// What exactly does this mean?
Employee X = new Employee();
```

In this example, the only real purpose of the `Employee` base class is to define common members for all subclasses. In all likelihood, you did not intend anyone to create a direct instance of this class, reason being that the `Employee` type itself is too general of a concept. For example, if I were to walk up to you and say, “I’m an employee!” I would bet your first question to me would be, “What *kind* of employee are you?” Are you a consultant, trainer, admin assistant, copyeditor, or White House aide?

Given that many base classes tend to be rather nebulous entities, a far better design for this example is to prevent the ability to directly create a new `Employee` object in code. In C#, you can enforce this programmatically by using the `abstract` keyword in the class definition, thus creating an *abstract base class*.

```
// Update the Employee class as abstract
// to prevent direct instantiation.
abstract partial class Employee
{
    ...
}
```

With this, if you now attempt to create an instance of the `Employee` class, you are issued a compile-time error.

```
// Error! Cannot create an instance of an abstract class!
Employee X = new Employee();
```

At first glance, it might seem strange to define a class that you cannot directly create an instance of. Recall, however, that base classes (abstract or not) are useful, in that they contain all the common data and functionality of derived types. Using this form of abstraction, you are able to model that the “idea” of an employee is completely valid; it is just not a concrete entity. Also understand that although you cannot *directly* create an instance of an abstract class, it is still assembled in memory when derived classes are created. Thus, it is perfectly fine (and common) for abstract classes to define any number of constructors that are called *indirectly* when derived classes are allocated.

At this point, you have constructed a fairly interesting employee hierarchy. You will add a bit more functionality to this application later in this chapter when examining C# casting rules. Until then, Figure 6-6 illustrates the crux of your current design.

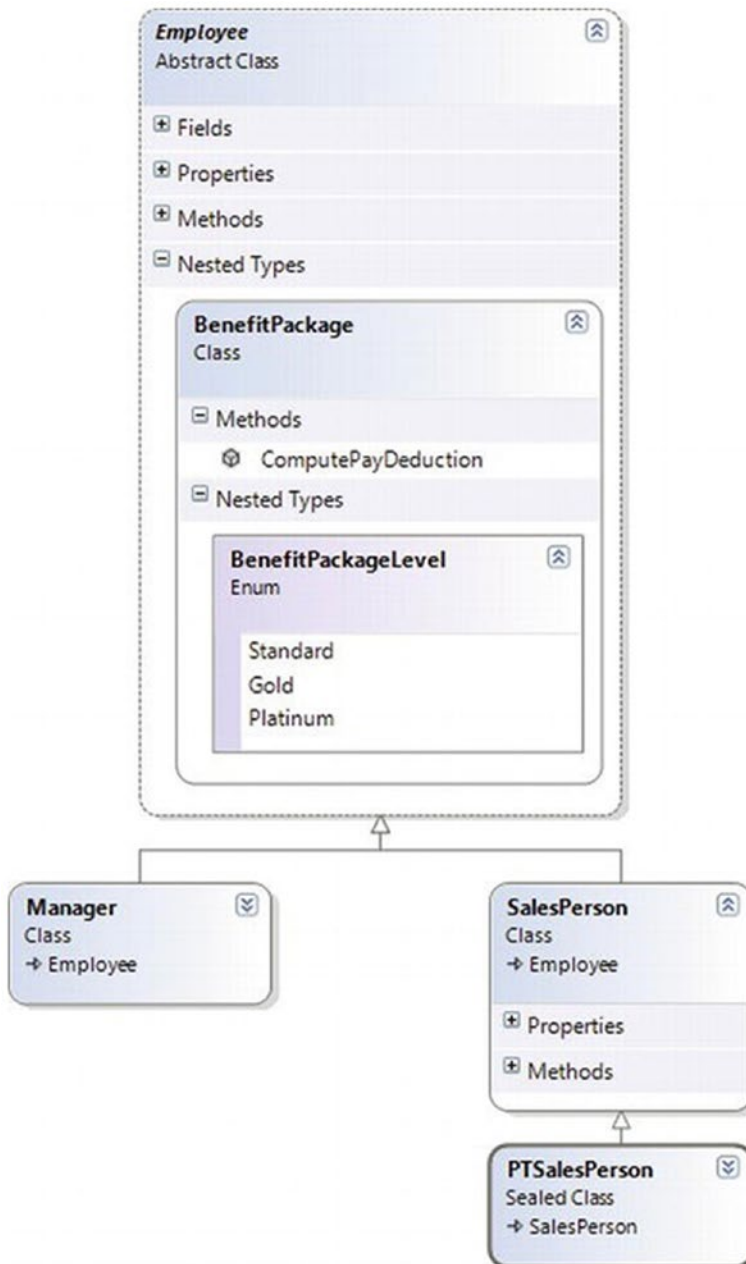

Figure 6-6. The Employee hierarchy

■ **Source Code** The Employees project is included in the Chapter 6 subdirectory.

Understanding the Polymorphic Interface

When a class has been defined as an abstract base class (via the `abstract` keyword), it may define any number of *abstract members*. Abstract members can be used whenever you want to define a member that does *not* supply a default implementation but *must* be accounted for by each derived class. By doing so, you enforce a *polymorphic interface* on each descendant, leaving them to contend with the task of providing the details behind your abstract methods.

Simply put, an abstract base class's polymorphic interface simply refers to its set of virtual and abstract methods. This is much more interesting than first meets the eye because this trait of OOP allows you to build easily extendable and flexible software applications. To illustrate, you will be implementing (and slightly modifying) the hierarchy of shapes briefly examined in Chapter 5 during the overview of the pillars of OOP. To begin, create a new C# Console Application project named Shapes.

In Figure 6-7, notice that the `Hexagon` and `Circle` types each extend the `Shape` base class. Like any base class, `Shape` defines a number of members (a `PetName` property and `Draw()` method, in this case) that are common to all descendants.

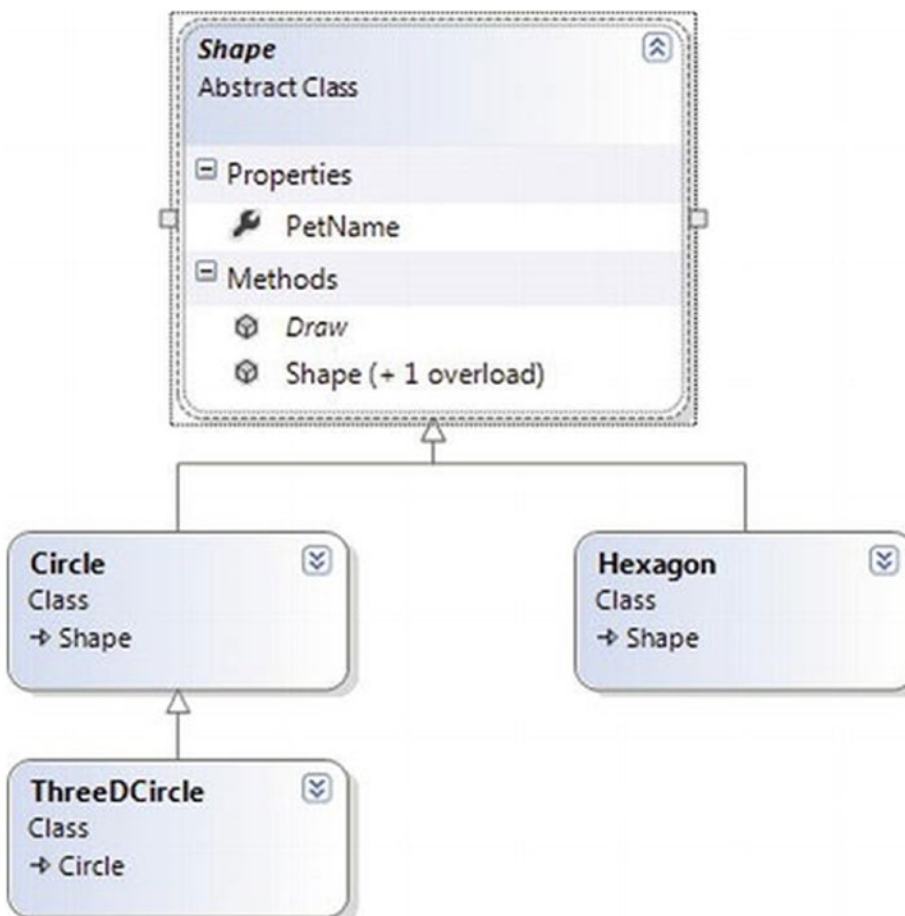

Figure 6-7. The shapes hierarchy

Much like the employee hierarchy, you should be able to tell that you don't want to allow the object user to create an instance of `Shape` directly, as it is too abstract of a concept. Again, to prevent the direct creation of the `Shape` type, you could define it as an abstract class. As well, given that you want the derived types to respond uniquely to the `Draw()` method, let's mark it as `virtual` and define a default implementation.

```
// The abstract base class of the hierarchy.
abstract class Shape
{
    public Shape(string name = "NoName")
    { PetName = name; }

    public string PetName { get; set; }

    // A single virtual method.
    public virtual void Draw()
    {
        Console.WriteLine("Inside Shape.Draw()");
    }
}
```

Notice that the virtual `Draw()` method provides a default implementation that simply prints out a message that informs you that you are calling the `Draw()` method within the `Shape` base class. Now recall that when a method is marked with the `virtual` keyword, the method provides a default implementation that all derived types automatically inherit. If a child class so chooses, it *may* override the method but does not *have* to. Given this, consider the following implementation of the `Circle` and `Hexagon` types:

```
// Circle DOES NOT override Draw().
class Circle : Shape
{
    public Circle() {}
    public Circle(string name) : base(name){}
}

// Hexagon DOES override Draw().
class Hexagon : Shape
{
    public Hexagon() {}
    public Hexagon(string name) : base(name){}
    public override void Draw()
    {
        Console.WriteLine("Drawing {0} the Hexagon", PetName);
    }
}
```

The usefulness of abstract methods becomes crystal clear when you once again remember that subclasses are *never required* to override virtual methods (as in the case of `Circle`). Therefore, if you create an instance of the `Hexagon` and `Circle` types, you'd find that the `Hexagon` understands how to “draw” itself correctly or at least print out an appropriate message to the console. The `Circle`, however, is more than a bit confused.

```
static void Main(string[] args)
{
    Console.WriteLine("***** Fun with Polymorphism *****\n");

    Hexagon hex = new Hexagon("Beth");
    hex.Draw();
    Circle cir = new Circle("Cindy");
    // Calls base class implementation!
    cir.Draw();
    Console.ReadLine();
}
```

Now consider the following output of the previous `Main()` method:

```
***** Fun with Polymorphism *****

Drawing Beth the Hexagon
Inside Shape.Draw()
```

Clearly, this is not an intelligent design for the current hierarchy. To force each child class to override the `Draw()` method, you can define `Draw()` as an abstract method of the `Shape` class, which by definition means you provide no default implementation whatsoever. To mark a method as abstract in C#, you use the `abstract` keyword. Notice that abstract members do not provide any implementation whatsoever.

```
abstract class Shape
{
    // Force all child classes to define how to be rendered.
    public abstract void Draw();
    ...
}
```

■ **Note** Abstract methods can be defined only in abstract classes. If you attempt to do otherwise, you will be issued a compiler error.

Methods marked with `abstract` are pure protocol. They simply define the name, return type (if any), and parameter set (if required). Here, the abstract `Shape` class informs the derived types that “I have a method named `Draw()` that takes no arguments and returns nothing. If you derive from me, you figure out the details.”

Given this, you are now obligated to override the `Draw()` method in the `Circle` class. If you do not, `Circle` is also assumed to be a noncreatable abstract type that must be adorned with the `abstract` keyword (which is obviously not useful in this example). Here is the code update:

```
// If we did not implement the abstract Draw() method, Circle would also be
// considered abstract, and would have to be marked abstract!
class Circle : Shape
{
    public Circle() {}
    public Circle(string name) : base(name) {}
    public override void Draw()
    {
        Console.WriteLine("Drawing {0} the Circle", PetName);
    }
}
```

The short answer is that you can now assume that anything deriving from `Shape` does indeed have a unique version of the `Draw()` method. To illustrate the full story of polymorphism, consider the following code:

```
static void Main(string[] args)
{
    Console.WriteLine("***** Fun with Polymorphism *****\n");

    // Make an array of Shape-compatible objects.
    Shape[] myShapes = {new Hexagon(), new Circle(), new Hexagon("Mick"),
        new Circle("Beth"), new Hexagon("Linda")};

    // Loop over each item and interact with the
    // polymorphic interface.
    foreach (Shape s in myShapes)
    {
        s.Draw();
    }
    Console.ReadLine();
}
```

Here is the output from the modified `Main()` method:

```
***** Fun with Polymorphism *****

Drawing NoName the Hexagon
Drawing NoName the Circle
Drawing Mick the Hexagon
Drawing Beth the Circle
Drawing Linda the Hexagon
```

This `Main()` method illustrates polymorphism at its finest. Although it is not possible to *directly* create an instance of an abstract base class (the `Shape`), you are able to freely store references to any subclass with an abstract base variable. Therefore, when you are creating an array of `Shapes`, the array can hold any object deriving from the `Shape` base class (if you attempt to place `Shape`-incompatible objects into the array, you receive a compiler error).

Given that all items in the `myShapes` array do indeed derive from `Shape`, you know they all support the same “polymorphic interface” (or said more plainly, they all have a `Draw()` method). As you iterate over the array of `Shape` references, it is at runtime that the underlying type is determined. At this point, the correct version of the `Draw()` method is invoked in memory.

This technique also makes it simple to safely extend the current hierarchy. For example, assume you derived more classes from the abstract `Shape` base class (`Triangle`, `Square`, etc.). Because of the polymorphic interface, the code within your `foreach` loop would not have to change in the slightest, as the compiler enforces that only `Shape`-compatible types are placed within the `myShapes` array.

Understanding Member Shadowing

C# provides a facility that is the logical opposite of method overriding, termed *shadowing*. Formally speaking, if a derived class defines a member that is identical to a member defined in a base class, the derived class has shadowed the parent’s version. In the real world, the possibility of this occurring is the greatest when you are subclassing from a class you (or your team) did not create yourself (such as when you purchase a third-party .NET software package).

For the sake of illustration, assume you receive a class named `ThreeDCircle` from a co-worker (or classmate) that defines a subroutine named `Draw()` taking no arguments.

```
class ThreeDCircle
{
    public void Draw()
    {
        Console.WriteLine("Drawing a 3D Circle");
    }
}
```

You figure that a `ThreeDCircle` “is-a” `Circle`, so you derive from your existing `Circle` type.

```
class ThreeDCircle : Circle
{
    public void Draw()
    {
        Console.WriteLine("Drawing a 3D Circle");
    }
}
```

After you recompile, you find the following warning:

```
'ThreeDCircle.Draw()' hides inherited member 'Circle.Draw()'. To make the
current member override that implementation, add the override keyword. Otherwise add the
new keyword.
```

The problem is that you have a derived class (`ThreeDCircle`) that contains a method that is identical to an inherited method. To address this issue, you have a few options. You could simply update the parent’s version of `Draw()` using the `override` keyword (as suggested by the compiler). With this approach, the `ThreeDCircle` type is able to extend the parent’s default behavior as required. However, if you don’t have access to the code defining the base class (again, as would be the case in many third-party libraries), you would be unable to modify the `Draw()` method as a virtual member, as you don’t have access to the code file!

As an alternative, you can include the new keyword to the offending `Draw()` member of the derived type (`ThreeDCircle`, in this example). Doing so explicitly states that the derived type's implementation is intentionally designed to effectively ignore the parent's version (again, in the real world, this can be helpful if external .NET software somehow conflicts with your current software).

```
// This class extends Circle and hides the inherited Draw() method.
class ThreeDCircle : Circle
{
    // Hide any Draw() implementation above me.
    public new void Draw()
    {
        Console.WriteLine("Drawing a 3D Circle");
    }
}
```

You can also apply the new keyword to any member type inherited from a base class (field, constant, static member, or property). As a further example, assume that `ThreeDCircle` wants to hide the inherited `PetName` property.

```
class ThreeDCircle : Circle
{
    // Hide the PetName property above me.
    public new string PetName { get; set; }

    // Hide any Draw() implementation above me.
    public new void Draw()
    {
        Console.WriteLine("Drawing a 3D Circle");
    }
}
```

Finally, be aware that it is still possible to trigger the base class implementation of a shadowed member using an explicit cast, as described in the next section. For example, the following code shows:

```
static void Main(string[] args)
{
    ...
    // This calls the Draw() method of the ThreeDCircle.
    ThreeDCircle o = new ThreeDCircle();
    o.Draw();

    // This calls the Draw() method of the parent!
    ((Circle)o).Draw();
    Console.ReadLine();
}
```

■ **Source Code** The Shapes project can be found in the Chapter 6 subdirectory.

Understanding Base Class/Derived Class Casting Rules

Now that you can build a family of related class types, you need to learn the rules of class *casting operations*. To do so, let's return to the Employees hierarchy created earlier in this chapter and add some new methods to the Program class (if you are following along, open the Employee project in Visual Studio). As described in the final section of this chapter, the ultimate base class in the system is System.Object. Therefore, everything "is-an" Object and can be treated as such. Given this fact, it is legal to store an instance of any type within an object variable.

```
static void CastingExamples()
{
    // A Manager "is-a" System.Object, so we can
    // store a Manager reference in an object variable just fine.
    object frank = new Manager("Frank Zappa", 9, 3000, 40000, "111-11-1111", 5);
}
```

In the Employees example, Managers, SalesPerson, and PTSalesPerson types all extend Employee, so you can store any of these objects in a valid base class reference. Therefore, the following statements are also legal:

```
static void CastingExamples()
{
    // A Manager "is-a" System.Object, so we can
    // store a Manager reference in an object variable just fine.
    object frank = new Manager("Frank Zappa", 9, 3000, 40000, "111-11-1111", 5);

    // A Manager "is-an" Employee too.
    Employee moonUnit = new Manager("MoonUnit Zappa", 2, 3001, 20000, "101-11-1321", 1);

    // A PTSalesPerson "is-a" SalesPerson.
    SalesPerson jill = new PTSalesPerson("Jill", 834, 3002, 100000, "111-12-1119", 90);
}
```

The first law of casting between class types is that when two classes are related by an "is-a" relationship, it is always safe to store a derived object within a base class reference. Formally, this is called an *implicit cast*, as "it just works" given the laws of inheritance. This leads to some powerful programming constructs. For example, assume you have defined a new method within your current Program class.

```
static void GivePromotion(Employee emp)
{
    // Increase pay...
    // Give new parking space in company garage...

    Console.WriteLine("{0} was promoted!", emp.Name);
}
```

Because this method takes a single parameter of type Employee, you can effectively pass any descendant from the Employee class into this method directly, given the "is-a" relationship.

```

static void CastingExamples()
{
    // A Manager "is-a" System.Object, so we can
    // store a Manager reference in an object variable just fine.
    object frank = new Manager("Frank Zappa", 9, 3000, 40000, "111-11-1111", 5);

    // A Manager "is-an" Employee too.
    Employee moonUnit = new Manager("MoonUnit Zappa", 2, 3001, 20000, "101-11-1321", 1);
    GivePromotion(moonUnit);

    // A PTSalesPerson "is-a" SalesPerson.
    SalesPerson jill = new PTSalesPerson("Jill", 834, 3002, 100000, "111-12-1119", 90);
    GivePromotion(jill);
}

```

The previous code compiles given the implicit cast from the base class type (`Employee`) to the derived type. However, what if you also wanted to fire Frank Zappa (currently stored in a general `System.Object` reference)? If you pass the `frank` object directly into this method, you will find a compiler error as follows:

```

object frank = new Manager("Frank Zappa", 9, 3000, 40000, "111-11-1111", 5);
// Error!
GivePromotion(frank);

```

The problem is that you are attempting to pass in a variable that is not declared as an `Employee` but a more general `System.Object`. Given that object is higher up the inheritance chain than `Employee`, the compiler will not allow for an implicit cast, in an effort to keep your code as type-safe as possible.

Even though you can figure out that the object reference is pointing to an `Employee`-compatible class in memory, the compiler cannot, as that will not be known until runtime. You can satisfy the compiler by performing an *explicit cast*. This is the second law of casting: you can, in such cases, explicitly downcast using the C# casting operator. The basic template to follow when performing an explicit cast looks something like the following:

```
(ClassIWantToCastTo)referenceIHave
```

Thus, to pass the object variable into the `GivePromotion()` method, you could author the following code:

```

// OK!
GivePromotion((Manager)frank);

```

The C# as Keyword

Be aware that explicit casting is evaluated at *runtime*, not compile time. For the sake of argument, assume your `Employees` project had a copy of the `Hexagon` class created earlier in this chapter. For simplicity, you could add the following class to the current project:

```

class Hexagon
{
    public void Draw() { Console.WriteLine("Drawing a hexagon!"); }
}

```

Although casting the employee object to a shape object makes absolutely no sense, code such as the following could compile without error:

```
// Ack! You can't cast frank to a Hexagon, but this compiles fine!
object frank = new Manager();
Hexagon hex = (Hexagon)frank;
```

However, you would receive a runtime error, or, more formally, a *runtime exception*. Chapter 7 will examine the full details of structured exception handling; however, it is worth pointing out, for the time being, that when you are performing an explicit cast, you can trap the possibility of an invalid cast using the try and catch keywords (again, see Chapter 7 for full details).

```
// Catch a possible invalid cast.
object frank = new Manager();
Hexagon hex;
try
{
    hex = (Hexagon)frank;
}
catch (InvalidCastException ex)
{
    Console.WriteLine(ex.Message);
}
```

Obviously this is a contrived example; you would never bother casting between these types in this situation. However, assume you have an array of `System.Object` types, only a few of which contain `Employee`-compatible objects. In this case, you would like to determine whether an item in an array is compatible to begin with and, if so, perform the cast.

C# provides the `as` keyword to quickly determine at runtime whether a given type is compatible with another. When you use the `as` keyword, you are able to determine compatibility by checking against a `null` return value. Consider the following:

```
// Use "as" to test compatibility.
object[] things = new object[4];
things[0] = new Hexagon();
things[1] = false;
things[2] = new Manager();
things[3] = "Last thing";

foreach (object item in things)
{
    Hexagon h = item as Hexagon;
    if (h == null)
        Console.WriteLine("Item is not a hexagon");
    else
    {
        h.Draw();
    }
}
```

Here you loop over each item in the array of objects, checking each one for compatibility with the Hexagon class. If (and only if!) you find a Hexagon-compatible object, you invoke the Draw() method. Otherwise, you simply report the items are not compatible.

The C# is Keyword

In addition to the as keyword, the C# language provides the is keyword to determine whether two items are compatible. Unlike the as keyword, however, the is keyword returns false, rather than a null reference if the types are incompatible. In other words, the is keyword does not perform any sort of cast; it just checks compatibility. If things are compatible, you can then perform a safe cast.

Currently, the GivePromotion() method has been designed to take any possible type derived from Employee. Consider the following update, which now checks to see exactly which “type of employee” you have been passed:

```
static void GivePromotion(Employee emp)
{
    Console.WriteLine("{0} was promoted!", emp.Name);

    if (emp is SalesPerson)
    {
        Console.WriteLine("{0} made {1} sale(s)!", emp.Name,
            ((SalesPerson)emp).SalesNumber);
        Console.WriteLine();
    }
    if (emp is Manager)
    {
        Console.WriteLine("{0} had {1} stock options...", emp.Name,
            ((Manager)emp).StockOptions);
        Console.WriteLine();
    }
}
```

Here, you are performing a runtime check to determine what the incoming base class reference is actually pointing to in memory. After you determine whether you received a SalesPerson or Manager type, you are able to perform an explicit cast to gain access to the specialized members of the class. Also notice that you are not required to wrap your casting operations within a try/catch construct, as you know that the cast is safe if you enter either if scope, given your conditional check.

The Master Parent Class: System.Object

To wrap up this chapter, I'd like to examine the details of the master parent class in the .NET platform: Object. As you were reading the previous section, you might have noticed that the base classes in your hierarchies (Car, Shape, Employee) never explicitly specify their parent classes.

```
// Who is the parent of Car?
class Car
{...}
```

In the .NET universe, every type ultimately derives from a base class named `System.Object`, which can be represented by the C# object keyword (lowercase *o*). The `Object` class defines a set of common members for every type in the framework. In fact, when you do build a class that does not explicitly define its parent, the compiler automatically derives your type from `Object`. If you want to be clear in your intentions, you are free to define classes that derive from `Object` as follows (however again, there is no need to do so):

```
// Here we are explicitly deriving from System.Object.
class Car : object
{...}
```

Like any class, `System.Object` defines a set of members. In the following formal C# definition, note that some of these items are declared `virtual`, which specifies that a given member may be overridden by a subclass, while others are marked with `static` (and are therefore called at the class level):

```
public class Object
{
    // Virtual members.
    public virtual bool Equals(object obj);
    protected virtual void Finalize();
    public virtual int GetHashCode();
    public virtual string ToString();

    // Instance-level, nonvirtual members.
    public Type GetType();
    protected object MemberwiseClone();

    // Static members.
    public static bool Equals(object objA, object objB);
    public static bool ReferenceEquals(object objA, object objB);
}
```

Table 6-1 offers a rundown of the functionality provided by some of the methods you're most likely to use.

Table 6-1. Core Members of `System.Object`

| Instance Method of Object Class | Meaning in Life |
|---------------------------------|---|
| <code>Equals()</code> | <p>By default, this method returns <code>true</code> only if the items being compared refer to the same item in memory. Thus, <code>Equals()</code> is used to compare object references, not the state of the object. Typically, this method is overridden to return <code>true</code> only if the objects being compared have the same internal state values (that is, value-based semantics).</p> <p>Be aware that if you override <code>Equals()</code>, you should also override <code>GetHashCode()</code>, as these methods are used internally by <code>Hashtable</code> types to retrieve subobjects from the container.</p> <p>Also recall from Chapter 4, that the <code>ValueType</code> class overrides this method for all structures, so they work with value-based comparisons.</p> |

(continued)

Table 6-1. (continued)

| Instance Method of Object Class | Meaning in Life |
|---------------------------------|---|
| Finalize() | For the time being, you can understand this method (when overridden) is called to free any allocated resources before the object is destroyed. I talk more about the CLR garbage collection services in Chapter 9. |
| GetHashCode() | This method returns an <code>int</code> that identifies a specific object instance. |
| ToString() | This method returns a string representation of this object, using the <code><namespace>. <type name></code> format (termed the <i>fully qualified name</i>). This method will often be overridden by a subclass to return a tokenized string of name/value pairs that represent the object's internal state, rather than its fully qualified name. |
| GetType() | This method returns a <code>Type</code> object that fully describes the object you are currently referencing. In short, this is a Runtime Type Identification (RTTI) method available to all objects (discussed in greater detail in Chapter 15). |
| MemberwiseClone() | This method exists to return a member-by-member copy of the current object, which is often used when cloning an object (see Chapter 8). |

To illustrate some of the default behavior provided by the `Object` base class, create a final C# Console Application project named `ObjectOverrides`. Insert a new C# class type that contains the following empty class definition for a type named `Person`:

```
// Remember! Person extends Object.
class Person { }
```

Now, update your `Main()` method to interact with the inherited members of `System.Object` as follows:

```
class Program
{
    static void Main(string[] args)
    {
        Console.WriteLine("***** Fun with System.Object *****\n");
        Person p1 = new Person();

        // Use inherited members of System.Object.
        Console.WriteLine("ToString: {0}", p1.ToString());
        Console.WriteLine("Hash code: {0}", p1.GetHashCode());
        Console.WriteLine("Type: {0}", p1.GetType());

        // Make some other references to p1.
        Person p2 = p1;
        object o = p2;
        // Are the references pointing to the same object in memory?
        if (o.Equals(p1) && p2.Equals(o))
        {
            Console.WriteLine("Same instance!");
        }
        Console.ReadLine();
    }
}
```

Here is the output of the current `Main()` method:

```
***** Fun with System.Object *****
```

```
ToString: ObjectOverrides.Person
Hash code: 46104728
Type: ObjectOverrides.Person
Same instance!
```

First, notice how the default implementation of `ToString()` returns the fully qualified name of the current type (`ObjectOverrides.Person`). As you will see later during the examination of building custom namespaces in Chapter 14, every C# project defines a “root namespace,” which has the same name of the project itself. Here, you created a project named `ObjectOverrides`; thus, the `Person` type and the `Program` class have both been placed within the `ObjectOverrides` namespace.

The default behavior of `Equals()` is to test whether two variables are pointing to the same object in memory. Here, you create a new `Person` variable named `p1`. At this point, a new `Person` object is placed on the managed heap. `p2` is also of type `Person`. However, you are not creating a *new* instance but rather assigning this variable to reference `p1`. Therefore, `p1` and `p2` are both pointing to the same object in memory, as is the variable `o` (of type `object`, which was thrown in for good measure). Given that `p1`, `p2`, and `o` all point to the same memory location, the equality test succeeds.

Although the canned behavior of `System.Object` can fit the bill in a number of cases, it is quite common for your custom types to override some of these inherited methods. To illustrate, update the `Person` class to support some properties representing an individual’s first name, last name, and age, each of which can be set by a custom constructor.

```
// Remember! Person extends Object.
class Person
{
    public string FirstName { get; set; } = "";
    public string LastName { get; set; } = "";
    public int Age { get; set; }

    public Person(string fName, string lName, int personAge)
    {
        FirstName = fName;
        LastName = lName;
        Age = personAge;
    }
    public Person(){}
}
```

Overriding `System.Object.ToString()`

Many classes (and structures) that you create can benefit from overriding `ToString()` in order to return a string textual representation of the type’s current state. This can be quite helpful for purposes of debugging (among other reasons). How you choose to construct this string is a matter of personal choice; however, a recommended approach is to separate each name-value pair with semicolons and wrap the entire string

within square brackets (many types in the .NET base class libraries follow this approach). Consider the following overridden `ToString()` for your `Person` class:

```
public override string ToString()
{
    string myState;
    myState = string.Format("[First Name: {0}; Last Name: {1}; Age: {2}]",
        FirstName, LastName, Age);
    return myState;
}
```

This implementation of `ToString()` is quite straightforward, given that the `Person` class has only three pieces of state data. However, always remember that a proper `ToString()` override should also account for any data defined *up the chain of inheritance*.

When you override `ToString()` for a class extending a custom base class, the first order of business is to obtain the `ToString()` value from your parent using the `base` keyword. After you have obtained your parent's string data, you can append the derived class's custom information.

Overriding `System.Object.Equals()`

Let's also override the behavior of `Object.Equals()` to work with value-based semantics. Recall that by default, `Equals()` returns `true` only if the two objects being compared reference the same object instance in memory. For the `Person` class, it may be helpful to implement `Equals()` to return `true` if the two variables being compared contain the same state values (e.g., first name, last name, and age).

First, notice that the incoming argument of the `Equals()` method is a general `System.Object`. Given this, your first order of business is to ensure the caller has indeed passed in a `Person` object and, as an extra safeguard, to make sure the incoming parameter is not a `null` reference.

After you have established the caller has passed you an allocated `Person`, one approach to implement `Equals()` is to perform a field-by-field comparison against the data of the incoming object to the data of the current object.

```
public override bool Equals(object obj)
{
    if (obj is Person && obj != null)
    {
        Person temp;
        temp = (Person)obj;
        if (temp.FirstName == this.FirstName
            && temp.LastName == this.LastName
            && temp.Age == this.Age)
        {
            return true;
        }
        else
        {
            return false;
        }
    }
    return false;
}
```

Here, you are examining the values of the incoming object against the values of your internal values (note the use of the `this` keyword). If the name and age of each are identical, you have two objects with the same state data and, therefore, return `true`. Any other possibility results in returning `false`.

While this approach does indeed work, you can certainly imagine how labor intensive it would be to implement a custom `Equals()` method for nontrivial types that may contain dozens of data fields. One common shortcut is to leverage your own implementation of `ToString()`. If a class has a prim-and- proper implementation of `ToString()` that accounts for all field data up the chain of inheritance, you can simply perform a comparison of the object's string data.

```
public override bool Equals(object obj)
{
    // No need to cast "obj" to a Person anymore,
    // as everything has a ToString() method.
    return obj.ToString() == this.ToString();
}
```

Notice in this case that you no longer need to check whether the incoming argument is of the correct type (a `Person`, in this example), as everything in .NET supports a `ToString()` method. Even better, you no longer need to perform a property-by-property equality check, as you are not simply testing the value returned from `ToString()`.

Overriding `System.Object.GetHashCode()`

When a class overrides the `Equals()` method, you should also override the default implementation of `GetHashCode()`. Simply put, a *hash code* is a numerical value that represents an object as a particular state. For example, if you create two `string` variables that hold the value `Hello`, you would obtain the same hash code. However, if one of the `string` objects were in all lowercase (`hello`), you would obtain different hash codes.

By default, `System.Object.GetHashCode()` uses your object's current location in memory to yield the hash value. However, if you are building a custom type that you intend to store in a `Hashtable` type (within the `System.Collections` namespace), you should always override this member, as the `Hashtable` will be internally invoking `Equals()` and `GetHashCode()` to retrieve the correct object.

■ **Note** To be more specific, the `System.Collections.Hashtable` class calls `GetHashCode()` internally to gain a general idea where the object is located, but a subsequent (internal) call to `Equals()` determines the exact match.

Although you are not going to place your `Person` into a `System.Collections.Hashtable`, for completion let's override `GetHashCode()`. There are many algorithms that can be used to create a hash code—some fancy, others not so fancy. Most of the time, you are able to generate a hash code value by leveraging the `System.String`'s `GetHashCode()` implementation.

Given that the `String` class already has a solid hash code algorithm that is using the character data of the `String` to compute a hash value, if you can identify a piece of field data on your class that should be unique for all instances (such as a Social Security number), simply call `GetHashCode()` on that point of field data. Thus, if the `Person` class defined an `SSN` property, you could author the following code:

```
// Assume we have an SSN property as so.
class Person
{
    public string SSN {get; set;} = "";

    // Return a hash code based on a point of unique string data.
    public override int GetHashCode()
    {
        return SSN.GetHashCode();
    }
}
```

If you cannot find a single point of unique string data but you have overridden `ToString()`, call `GetHashCode()` on your own string representation:

```
// Return a hash code based on the person's ToString() value.
public override int GetHashCode()
{
    return this.ToString().GetHashCode();
}
```

Testing Your Modified Person Class

Now that you have overridden the virtual members of `Object`, update `Main()` to test your updates.

```
static void Main(string[] args)
{
    Console.WriteLine("***** Fun with System.Object *****\n");

    // NOTE: We want these to be identical to test
    // the Equals() and GetHashCode() methods.
    Person p1 = new Person("Homer", "Simpson", 50);
    Person p2 = new Person("Homer", "Simpson", 50);

    // Get stringified version of objects.
    Console.WriteLine("p1.ToString() = {0}", p1.ToString());
    Console.WriteLine("p2.ToString() = {0}", p2.ToString());

    // Test overridden Equals().
    Console.WriteLine("p1 = p2?: {0}", p1.Equals(p2));

    // Test hash codes.
    Console.WriteLine("Same hash codes?: {0}", p1.GetHashCode() == p2.GetHashCode());
    Console.WriteLine();
}
```

```

// Change age of p2 and test again.
p2.Age = 45;
Console.WriteLine("p1.ToString() = {0}", p1.ToString());
Console.WriteLine("p2.ToString() = {0}", p2.ToString());
Console.WriteLine("p1 = p2?: {0}", p1.Equals(p2));
Console.WriteLine("Same hash codes?: {0}", p1.GetHashCode() == p2.GetHashCode());
Console.ReadLine();
}

```

The output is shown here:

```

***** Fun with System.Object *****

```

```

p1.ToString() = [First Name: Homer; Last Name: Simpson; Age: 50]
p2.ToString() = [First Name: Homer; Last Name: Simpson; Age: 50]
p1 = p2?: True
Same hash codes?: True

```

```

p1.ToString() = [First Name: Homer; Last Name: Simpson; Age: 50]
p2.ToString() = [First Name: Homer; Last Name: Simpson; Age: 45]
p1 = p2?: False
Same hash codes?: False

```

The Static Members of System.Object

In addition to the instance-level members you have just examined, `System.Object` does define two (very helpful) static members that also test for value-based or reference-based equality. Consider the following code:

```

static void StaticMembersOfObject()
{
    // Static members of System.Object.
    Person p3 = new Person("Sally", "Jones", 4);
    Person p4 = new Person("Sally", "Jones", 4);
    Console.WriteLine("P3 and P4 have same state: {0}", object.Equals(p3, p4));
    Console.WriteLine("P3 and P4 are pointing to same object: {0}",
        object.ReferenceEquals(p3, p4));
}

```

Here, you are able to simply send in two objects (of any type) and allow the `System.Object` class to determine the details automatically.

■ **Source Code** The `ObjectOverrides` project is located in the Chapter 6 subdirectory.

Summary

This chapter explored the role and details of inheritance and polymorphism. Over these pages you were introduced to numerous new keywords and tokens to support each of these techniques. For example, recall that the colon token is used to establish the parent class of a given type. Parent types are able to define any number of virtual and/or abstract members to establish a polymorphic interface. Derived types override such members using the `override` keyword.

In addition to building numerous class hierarchies, this chapter also examined how to explicitly cast between base and derived types and wrapped up by diving into the details of the cosmic parent class in the .NET base class libraries: `System.Object`.

CHAPTER 7



Understanding Structured Exception Handling

In this chapter, you will learn how to handle runtime anomalies in your C# code through the use of *structured exception handling*. Not only will you examine the C# keywords that allow you to handle such matters (`try`, `catch`, `throw`, `finally`, `when`), but you will also come to understand the distinction between application-level and system-level exceptions, as well as the role of the `System.Exception` base class. This discussion will lead into the topic of building custom exceptions and, finally, to a quick look at some exception-centric debugging tools of Visual Studio.

Ode to Errors, Bugs, and Exceptions

Despite what our (sometimes inflated) egos may tell us, no programmer is perfect. Writing software is a complex undertaking, and given this complexity, it is quite common for even the best software to ship with various *problems*. Sometimes the problem is caused by bad code (such as overflowing the bounds of an array). Other times, a problem is caused by bogus user input that has not been accounted for in the application's code base (e.g., a phone number input field assigned to the value `Chucky`). Now, regardless of the cause of the problem, the end result is that the application does not work as expected. To help frame the upcoming discussion of structured exception handling, allow me to provide definitions for three commonly used anomaly-centric terms.

- *Bugs*: These are, simply put, errors made by the programmer. For example, suppose you are programming with unmanaged C++. If you fail to delete dynamically allocated memory, resulting in a memory leak, you have a bug.
- *User errors*: User errors, on the other hand, are typically caused by the individual running your application, rather than by those who created it. For example, an end user who enters a malformed string into a text box could very well generate an error if you fail to handle this faulty input in your code base.
- *Exceptions*: Exceptions are typically regarded as runtime anomalies that are difficult, if not impossible, to account for while programming your application. Possible exceptions include attempting to connect to a database that no longer exists, opening a corrupted XML file, or trying to contact a machine that is currently offline. In each of these cases, the programmer (or end user) has little control over these “exceptional” circumstances.

Given these definitions, it should be clear that .NET structured *exception* handling is a technique for dealing with runtime *exceptions*. However, even for the bugs and user errors that have escaped your view, the CLR will often generate a corresponding exception that identifies the problem at hand. By way of a few examples, the .NET base class libraries define numerous exceptions, such as `FormatException`, `IndexOutOfRangeException`, `FileNotFoundException`, `ArgumentOutOfRangeException`, and so forth.

Within the .NET nomenclature, an *exception* accounts for bugs, bogus user input, and runtime errors, even though programmers may view each of these as a distinct issue. However, before I get too far ahead of myself, let's formalize the role of structured exception handling and check out how it differs from traditional error-handling techniques.

■ **Note** To make the code examples used in this book as clean as possible, I will not catch every possible exception that may be thrown by a given method in the base class libraries. In your production-level projects, you should, of course, make liberal use of the techniques presented in this chapter.

The Role of .NET Exception Handling

Prior to .NET, error handling under the Windows operating system was a confused mishmash of techniques. Many programmers rolled their own error-handling logic within the context of a given application. For example, a development team could define a set of numerical constants that represented known error conditions and make use of them as method return values. By way of an example, consider the following partial C code:

```
/* A very C-style error trapping mechanism. */
#define E_FILENOTFOUND 1000

int UseFileSystem()
{
    // Assume something happens in this function
    // that causes the following return value.
    return E_FILENOTFOUND;
}

void main()
{
    int retVal = UseFileSystem();
    if(retVal == E_FILENOTFOUND)
        printf("Cannot find file...");
}
```

This approach is less than ideal, given the fact that the constant `E_FILENOTFOUND` is little more than a numerical value and is far from being a helpful agent regarding how to deal with the problem. Ideally, you would like to wrap the error's name, a descriptive message, and other helpful information about this error condition into a single, well-defined package (which is exactly what happens under structured exception handling). In addition to a developer's ad hoc techniques, the Windows API defines hundreds of error codes that come by way of `#defines`, `HRESULTS`, and far too many variations on the simple Boolean (`bool`, `BOOL`, `VARIANT_BOOL`, and so on).

The obvious problem with these older techniques is the tremendous lack of symmetry. Each approach is more or less tailored to a given technology, a given language, and perhaps even a given project. To put an end to this madness, the .NET platform provides a standard technique to send and trap runtime errors: structured exception handling. The beauty of this approach is that developers now have a unified approach to error handling, which is common to all languages targeting the .NET platform. Therefore, the way in which a C# programmer handles errors is syntactically similar to that of a VB programmer, or a C++ programmer using C++/CLI.

As an added bonus, the syntax used to throw and catch exceptions across assemblies and machine boundaries is identical. For example, if you use C# to build a Windows Communication Foundation (WCF) service, you can throw a SOAP fault to a remote caller, using the same keywords that allow you to throw an exception between methods in the same application.

Another bonus of .NET exceptions is that rather than receiving a cryptic numerical value, exceptions are objects that contain a human-readable description of the problem, as well as a detailed snapshot of the call stack that triggered the exception in the first place. Furthermore, you are able to give the end user help-link information that points the user to a URL that provides details about the error, as well as custom programmer-defined data.

The Building Blocks of .NET Exception Handling

Programming with structured exception handling involves the use of four interrelated entities.

- A class type that represents the details of the exception
- A member that *throws* an instance of the exception class to the caller under the correct circumstances
- A block of code on the caller's side that invokes the exception-prone member
- A block of code on the caller's side that will process (or *catch*) the exception, should it occur

The C# programming language offers five keywords (*try*, *catch*, *throw*, *finally*, and *when*) that allow you to throw and handle exceptions. The object that represents the problem at hand is a class extending `System.Exception` (or a descendent thereof). Given this fact, let's check out the role of this exception-centric base class.

The System.Exception Base Class

All exceptions ultimately derive from the `System.Exception` base class, which in turn derives from `System.Object`. Here is the crux of this class (note that some of these members are virtual and may thus be overridden by derived classes):

```
public class Exception : ISerializable, _Exception
{
    // Public constructors
    public Exception(string message, Exception innerException);
    public Exception(string message);
    public Exception();
    ...

    // Methods
    public virtual Exception GetBaseException();
    public virtual void GetObjectData(SerializationInfo info,
        StreamingContext context);
}
```

```
// Properties
public virtual IDictionary Data { get; }
public virtual string HelpLink { get; set; }
public Exception InnerException { get; }
public virtual string Message { get; }
public virtual string Source { get; set; }
public virtual string StackTrace { get; }
public MethodBase TargetSite { get; }
...
}
```

As you can see, many of the properties defined by `System.Exception` are read-only in nature. This is because derived types will typically supply default values for each property. For example, the default message of the `IndexOutOfRangeException` type is “Index was outside the bounds of the array.”

■ **Note** The `Exception` class implements two .NET interfaces. Although you have yet to examine interfaces (see Chapter 8), just understand that the `_Exception` interface allows a .NET exception to be processed by an unmanaged code base (such as a COM application), while the `ISerializable` interface allows an exception object to be persisted across boundaries (such as a machine boundary).

Table 7-1 describes the most important members of `System.Exception`.

Table 7-1. Core Members of the `System.Exception` Type

| System.Exception Property | Meaning in Life |
|---------------------------|--|
| Data | This read-only property retrieves a collection of key/value pairs (represented by an object implementing <code>IDictionary</code>) that provide additional, programmer-defined information about the exception. By default, this collection is empty. |
| HelpLink | This property gets or sets a URL to a help file or web site describing the error in full detail. |
| InnerException | This read-only property can be used to obtain information about the previous exception(s) that caused the current exception to occur. The previous exception(s) are recorded by passing them into the constructor of the most current exception. |
| Message | This read-only property returns the textual description of a given error. The error message itself is set as a constructor parameter. |
| Source | This property gets or sets the name of the assembly, or the object, that threw the current exception. |
| StackTrace | This read-only property contains a string that identifies the sequence of calls that triggered the exception. As you might guess, this property is useful during debugging or if you want to dump the error to an external error log. |
| TargetSite | This read-only property returns a <code>MethodBase</code> object, which describes numerous details about the method that threw the exception (invoking <code>ToString()</code> will identify the method by name). |

The Simplest Possible Example

To illustrate the usefulness of structured exception handling, you need to create a class that will throw an exception under the correct (or one might say *exceptional*) circumstances. Assume you have created a new C# Console Application project (named SimpleException) that defines two class types (Car and Radio) associated by the “has-a” relationship. The Radio type defines a single method that turns the radio’s power on or off.

```
class Radio
{
    public void TurnOn(bool on)
    {
        if(on)
            Console.WriteLine("Jamming...");
        else
            Console.WriteLine("Quiet time...");
    }
}
```

In addition to leveraging the Radio class via containment/delegation, the Car class (shown next) is defined in such a way that if the user accelerates a Car object beyond a predefined maximum speed (specified using a constant member variable named MaxSpeed), its engine explodes, rendering the Car unusable (captured by a private bool member variable named carIsDead).

Beyond these points, the Car type has a few properties to represent the current speed and a user supplied “pet name,” as well as various constructors to set the state of a new Car object. Here is the complete definition (with code comments):

```
class Car
{
    // Constant for maximum speed.
    public const int MaxSpeed = 100;

    // Car properties.
    public int CurrentSpeed {get; set;} = 0;
    public string PetName {get; set;} = "";

    // Is the car still operational?
    private bool carIsDead;

    // A car has-a radio.
    private Radio theMusicBox = new Radio();

    // Constructors.
    public Car() {}
    public Car(string name, int speed)
    {
        CurrentSpeed = speed;
        PetName = name;
    }
}
```

```

public void CrankTunes(bool state)
{
    // Delegate request to inner object.
    theMusicBox.TurnOn(state);
}

// See if Car has overheated.
public void Accelerate(int delta)
{
    if (carIsDead)
        Console.WriteLine("{0} is out of order...", PetName);
    else
    {
        CurrentSpeed += delta;
        if (CurrentSpeed > MaxSpeed)
        {
            Console.WriteLine("{0} has overheated!", PetName);
            CurrentSpeed = 0;
            carIsDead = true;
        }
        else
            Console.WriteLine("=> CurrentSpeed = {0}", CurrentSpeed);
    }
}
}

```

Now, if you implement a `Main()` method that forces a `Car` object to exceed the predefined maximum speed (set to 100, in the `Car` class) as shown here:

```

static void Main(string[] args)
{
    Console.WriteLine("***** Simple Exception Example *****");
    Console.WriteLine("=> Creating a car and stepping on it!");
    Car myCar = new Car("Zippy", 20);
    myCar.CrankTunes(true);

    for (int i = 0; i < 10; i++)
        myCar.Accelerate(10);
    Console.ReadLine();
}

```

you would see the following output:

```

***** Simple Exception Example *****
=> Creating a car and stepping on it!
Jamming...
=> CurrentSpeed = 30
=> CurrentSpeed = 40
=> CurrentSpeed = 50
=> CurrentSpeed = 60
=> CurrentSpeed = 70

```

```
=> CurrentSpeed = 80
=> CurrentSpeed = 90
=> CurrentSpeed = 100
Zippy has overheated!
Zippy is out of order...
```

Throwing a General Exception

Now that you have a functional `Car` class, I'll demonstrate the simplest way to throw an exception. The current implementation of `Accelerate()` simply displays an error message if the caller attempts to speed up the `Car` beyond its upper limit.

To retrofit this method to throw an exception if the user attempts to speed up the automobile after it has met its maker, you want to create and configure a new instance of the `System.Exception` class, setting the value of the read-only `Message` property via the class constructor. When you want to send the exception object back to the caller, use the C# `throw` keyword. Here is the relevant code update to the `Accelerate()` method:

```
// This time, throw an exception if the user speeds up beyond MaxSpeed.
public void Accelerate(int delta)
{
    if (carIsDead)
        Console.WriteLine("{0} is out of order...", PetName);
    else
    {
        CurrentSpeed += delta;
        if (CurrentSpeed >= MaxSpeed)
        {
            carIsDead = true;
            CurrentSpeed = 0;

            // Use the "throw" keyword to raise an exception.
            throw new Exception(string.Format("{0} has overheated!", PetName));
        }
        else
            Console.WriteLine("=> CurrentSpeed = {0}", CurrentSpeed);
    }
}
```

Before examining how a caller would catch this exception, let's look at a few points of interest. First, when you are throwing an exception, it is always up to you to decide exactly what constitutes the error in question and when an exception should be thrown. Here, you are making the assumption that if the program attempts to increase the speed of a `Car` object beyond the maximum, a `System.Exception` object should be thrown to indicate the `Accelerate()` method cannot continue (which may or may not be a valid assumption; this will be a judgment call on your part based on the application you are creating).

Alternatively, you could implement `Accelerate()` to recover automatically without needing to throw an exception in the first place. By and large, exceptions should be thrown only when a more terminal condition has been met (for example, not finding a necessary file, failing to connect to a database, and the like). Deciding exactly what justifies throwing an exception is a design issue you must always contend with. For the current purposes, assume that asking a doomed automobile to increase its speed is cause to throw an exception.

In any case, if you were to rerun the application at this point using the previous logic in `Main()`, the exception will eventually be thrown. As shown in the following output, the result of not handling this error is less than ideal, given you receive a verbose error dump followed by the program's termination:

```
***** Simple Exception Example *****
=> Creating a car and stepping on it!
Jamming...
=> CurrentSpeed = 30
=> CurrentSpeed = 40
=> CurrentSpeed = 50
=> CurrentSpeed = 60
=> CurrentSpeed = 70
=> CurrentSpeed = 80
=> CurrentSpeed = 90
```

```
Unhandled Exception: System.Exception: Zippy has overheated!
   at SimpleException.Car.Accelerate(Int32 delta) in C:\MyBooks\C# Book (7th ed)
\Code\Chapter_7\SimpleException\Car.cs:line 62
   at SimpleException.Program.Main(String[] args) in C:\MyBooks\C# Book (7th ed)
\Code\Chapter_7\SimpleException\Program.cs:line 20
Press any key to continue . . .
```

Catching Exceptions

■ **Note** For those coming to .NET from a Java background, understand that type members are not prototyped with the set of exceptions they may throw (in other words, .NET does not support checked exceptions). For better or for worse, you are not required to handle every exception thrown from a given member.

Because the `Accelerate()` method now throws an exception, the caller needs to be ready to handle the exception, should it occur. When you are invoking a method that may throw an exception, you make use of a try/catch block. After you have caught the exception object, you are able to invoke the members of the exception object to extract the details of the problem.

What you do with this data is largely up to you. You might want to log this information to a report file, write the data to the Windows event log, e-mail a system administrator, or display the problem to the end user. Here, you will simply dump the contents to the console window:

```
// Handle the thrown exception.
static void Main(string[] args)
{
    Console.WriteLine("***** Simple Exception Example *****");
    Console.WriteLine("=> Creating a car and stepping on it!");
    Car myCar = new Car("Zippy", 20);
    myCar.CrankTunes(true);
}
```

```

// Speed up past the car's max speed to
// trigger the exception.
try
{
    for(int i = 0; i < 10; i++)
        myCar. Accelerate(10);
}
catch(Exception e)
{
    Console.WriteLine("\n*** Error! ***");
    Console.WriteLine("Method: {0}", e.TargetSite);
    Console.WriteLine("Message: {0}", e.Message);
    Console.WriteLine("Source: {0}", e.Source);
}

// The error has been handled, processing continues with the next statement.
Console.WriteLine("\n***** Out of exception logic *****");
Console.ReadLine();
}

```

In essence, a try block is a section of statements that may throw an exception during execution. If an exception is detected, the flow of program execution is sent to the appropriate catch block. On the other hand, if the code within a try block does not trigger an exception, the catch block is skipped entirely, and all is right with the world. The following output shows a test run of this program:

```

***** Simple Exception Example *****
=> Creating a car and stepping on it!
Jamming...
=> CurrentSpeed = 30
=> CurrentSpeed = 40
=> CurrentSpeed = 50
=> CurrentSpeed = 60
=> CurrentSpeed = 70
=> CurrentSpeed = 80
=> CurrentSpeed = 90

*** Error! ***
Method: Void Accelerate(Int32)
Message: Zippy has overheated!
Source: SimpleException

***** Out of exception logic *****

```

As you can see, after an exception has been handled, the application is free to continue on from the point after the catch block. In some circumstances, a given exception could be critical enough to warrant the termination of the application. However, in a good number of cases, the logic within the exception handler will ensure the application can continue on its merry way (although it could be slightly less functional, such as not being able to connect to a remote data source).

Configuring the State of an Exception

Currently, the `System.Exception` object configured within the `Accelerate()` method simply establishes a value exposed to the `Message` property (via a constructor parameter). As shown previously in Table 7-1, however, the `Exception` class also supplies a number of additional members (`TargetSite`, `StackTrace`, `HelpLink`, and `Data`) that can be useful in further qualifying the nature of the problem. To spruce up the current example, let's examine further details of these members on a case-by-case basis.

The `TargetSite` Property

The `System.Exception.TargetSite` property allows you to determine various details about the method that threw a given exception. As shown in the previous `Main()` method, printing the value of `TargetSite` will display the return type, name, and parameter types of the method that threw the exception. However, `TargetSite` does not return just a vanilla-flavored string but rather a strongly typed `System.Reflection.MethodBase` object. This type can be used to gather numerous details regarding the offending method, as well as the class that defines the offending method. To illustrate, assume the previous catch logic has been updated as follows:

```
static void Main(string[] args)
{
    ...
    // TargetSite actually returns a MethodBase object.
    catch(Exception e)
    {
        Console.WriteLine("\n*** Error! ***");
        Console.WriteLine("Member name: {0}", e.TargetSite);
        Console.WriteLine("Class defining member: {0}",
            e.TargetSite.DeclaringType);
        Console.WriteLine("Member type: {0}", e.TargetSite.MemberType);
        Console.WriteLine("Message: {0}", e.Message);
        Console.WriteLine("Source: {0}", e.Source);
    }
    Console.WriteLine("\n***** Out of exception logic *****");
    Console.ReadLine();
}
```

This time, you make use of the `MethodBase.DeclaringType` property to determine the fully qualified name of the class that threw the error (`SimpleException.Car`, in this case) as well as the `MemberType` property of the `MethodBase` object to identify the type of member (such as a property versus a method) where this exception originated. In this case, the catch logic would display the following:

```
*** Error! ***
Member name: Void Accelerate(Int32)
Class defining member: SimpleException.Car
Member type: Method
Message: Zippy has overheated!
Source: SimpleException
```

The StackTrace Property

The `System.Exception.StackTrace` property allows you to identify the series of calls that resulted in the exception. Be aware that you never set the value of `StackTrace`, as it is established automatically at the time the exception is created. To illustrate, assume you have once again updated your catch logic.

```
catch(Exception e)
{
    ...
    Console.WriteLine("Stack: {0}", e.StackTrace);
}
```

If you were to run the program, you would find the following stack trace is printed to the console (your line numbers and file paths may differ, of course):

```
Stack: at SimpleException.Car.Accelerate(Int32 delta)
in c:\MyApps\SimpleException\car.cs:line 65 at SimpleException.Program.Main()
in c:\MyApps\SimpleException\Program.cs:line 21
```

The string returned from `StackTrace` documents the sequence of calls that resulted in the throwing of this exception. Notice how the bottommost line number of this string identifies the first call in the sequence, while the topmost line number identifies the exact location of the offending member. Clearly, this information can be quite helpful during the debugging or logging of a given application, as you are able to “follow the flow” of the error’s origin.

The HelpLink Property

While the `TargetSite` and `StackTrace` properties allow programmers to gain an understanding of a given exception, this information is of little use to the end user. As you have already seen, the `System.Exception.Message` property can be used to obtain human-readable information that can be displayed to the current user. In addition, the `HelpLink` property can be set to point the user to a specific URL or standard Windows help file that contains more detailed information.

By default, the value managed by the `HelpLink` property is an empty string. If you want to fill this property with a more interesting value, you need to do so before throwing the `System.Exception` object. Here are the relevant updates to the `Car.Accelerate()` method:

```
public void Accelerate(int delta)
{
    if (carIsDead)
        Console.WriteLine("{0} is out of order...", PetName);
    else
    {
        CurrentSpeed += delta;
        if (CurrentSpeed >= MaxSpeed)
        {
            carIsDead = true;
            CurrentSpeed = 0;
        }
    }
}
```

```

    // We need to call the HelpLink property, thus we need to
    // create a local variable before throwing the Exception object.
    Exception ex =
        new Exception(string.Format("{0} has overheated!", PetName));
    ex.HelpLink = "http://www.CarsRUs.com";
    throw ex;
}
else
    Console.WriteLine("=> CurrentSpeed = {0}", CurrentSpeed);
}
}

```

The catch logic could now be updated to print this help link information as follows:

```

catch(Exception e)
{
    ...
    Console.WriteLine("Help Link: {0}", e.HelpLink);
}

```

The Data Property

The Data property of `System.Exception` allows you to fill an exception object with relevant auxiliary information (such as a timestamp). The Data property returns an object implementing an interface named `IDictionary`, defined in the `System.Collections` namespace. Chapter 8 examines the role of interface-based programming, as well as the `System.Collections` namespace. For the time being, just understand that dictionary collections allow you to create a set of values that are retrieved using a specific key. Observe the next update to the `Car.Accelerate()` method:

```

public void Accelerate(int delta)
{
    if (carIsDead)
        Console.WriteLine("{0} is out of order...", PetName);
    else
    {
        CurrentSpeed += delta;
        if (CurrentSpeed >= MaxSpeed)
        {
            carIsDead = true;
            CurrentSpeed = 0;

            // We need to call the HelpLink property, thus we need
            // to create a local variable before throwing the Exception object.
            Exception ex =
                new Exception(string.Format("{0} has overheated!", PetName));
            ex.HelpLink = "http://www.CarsRUs.com";

```



```

    // Stuff in custom data regarding the error.
    ex.Data.Add("TimeStamp",
        string.Format("The car exploded at {0}", DateTime.Now));
    ex.Data.Add("Cause", "You have a lead foot.");
    throw ex;
}
else
    Console.WriteLine("=> CurrentSpeed = {0}", CurrentSpeed);
}
}

```

To successfully enumerate over the key-value pairs, you must first make sure to specify a `using` directive for the `System.Collections` namespace, since you will use a `DictionaryEntry` type in the file containing the class implementing your `Main()` method.

```
using System.Collections;
```

Next, you need to update the catch logic to test that the value returned from the `Data` property is not null (the default value). After that, you use the `Key` and `Value` properties of the `DictionaryEntry` type to print the custom data to the console.

```

catch (Exception e)
{
    ...
    Console.WriteLine("\n-> Custom Data:");
    foreach (DictionaryEntry de in e.Data)
        Console.WriteLine("-> {0}: {1}", de.Key, de.Value);
}

```

With this, here's the final output you'd see:

```

***** Simple Exception Example *****
=> Creating a car and stepping on it!
Jamming...
=> CurrentSpeed = 30
=> CurrentSpeed = 40
=> CurrentSpeed = 50
=> CurrentSpeed = 60
=> CurrentSpeed = 70
=> CurrentSpeed = 80
=> CurrentSpeed = 90

*** Error! ***
Member name: Void Accelerate(Int32)
Class defining member: SimpleException.Car
Member type: Method
Message: Zippy has overheated!
Source: SimpleException
Stack: at SimpleException.Car.Accelerate(Int32 delta)
       at SimpleException.Program.Main(String[] args)
Help Link: http://www.CarsRUs.com

```

```
-> Custom Data:
-> TimeStamp: The car exploded at 9/12/2015 9:02:12 PM
-> Cause: You have a lead foot.
```

```
***** Out of exception logic *****
```

The Data property is useful in that it allows you to pack in custom information regarding the error at hand, without requiring the building of a new class type to extend the `Exception` base class. As helpful as the Data property may be, however, it is still common for .NET developers to build strongly typed exception classes, which handle custom data using strongly typed properties.

This approach allows the caller to catch a specific exception-derived type, rather than having to dig into a data collection to obtain additional details. To understand how to do this, you need to examine the distinction between system-level and application-level exceptions.

■ **Source Code** The `SimpleException` project is included in the Chapter 7 subdirectory.

System-Level Exceptions (System.SystemException)

The .NET base class libraries define many classes that ultimately derive from `System.Exception`. For example, the `System` namespace defines core exception objects such as `ArgumentOutOfRangeException`, `IndexOutOfRangeException`, `StackOverflowException`, and so forth. Other namespaces define exceptions that reflect the behavior of that namespace. For example, `System.Drawing.Printing` defines printing exceptions, `System.IO` defines input/output-based exceptions, `System.Data` defines database-centric exceptions, and so forth.

Exceptions that are thrown by the .NET platform are (appropriately) called *system exceptions*. These exceptions are generally regarded as nonrecoverable, fatal errors. System exceptions derive directly from a base class named `System.SystemException`, which in turn derives from `System.Exception` (which derives from `System.Object`).

```
public class SystemException : Exception
{
    // Various constructors.
}
```

Given that the `System.SystemException` type does not add any additional functionality beyond a set of custom constructors, you might wonder why `SystemException` exists in the first place. Simply put, when an exception type derives from `System.SystemException`, you are able to determine that the .NET runtime is the entity that has thrown the exception, rather than the code base of the executing application. You can verify this quite simply using the `is` keyword.

```
// True! NullReferenceException is-a SystemException.
NullReferenceException nullRefEx = new NullReferenceException();
Console.WriteLine("NullReferenceException is-a SystemException? : {0}",
    nullRefEx is SystemException);
```

Application-Level Exceptions (System.ApplicationException)

Given that all .NET exceptions are class types, you are free to create your own application-specific exceptions. However, because the `System.SystemException` base class represents exceptions thrown from the CLR, you might naturally assume that you should derive your custom exceptions from the `System.Exception` type. You could do this, but you could instead derive from the `System.ApplicationException` class.

```
public class ApplicationException : Exception
{
    // Various constructors.
}
```

Like `SystemException`, `ApplicationException` does not define any additional members beyond a set of constructors. Functionally, the only purpose of `System.ApplicationException` is to identify the source of the error. When you handle an exception deriving from `System.ApplicationException`, you can assume the exception was raised by the code base of the executing application, rather than by the .NET base class libraries or .NET runtime engine.

■ **Note** In practice, few .NET developers build custom exceptions that extend `ApplicationException`. Rather, it is more common to simply subclass `System.Exception`; however, either approach is technically valid.

Building Custom Exceptions, Take 1

While you can always throw instances of `System.Exception` to signal a runtime error (as shown in the first example), it is sometimes advantageous to build a *strongly typed exception* that represents the unique details of your current problem. For example, assume you want to build a custom exception (named `CarIsDeadException`) to represent the error of speeding up a doomed automobile. The first step is to derive a new class from `System.Exception/System.ApplicationException` (by convention, all exception classes end with the `Exception` suffix; in fact, this is a .NET best practice).

■ **Note** As a rule, all custom exception classes should be defined as public classes (recall, the default access modifier of a non-nested type is `internal`). The reason is that exceptions are often passed outside of assembly boundaries and should therefore be accessible to the calling code base.

Create a new Console Application project named `CustomException`, and copy the previous `Car.cs` and `Radio.cs` files into your new project using the Project Add Existing Item menu option (for clarity, be sure to change the namespace that defines the `Car` and `Radio` types from `SimpleException` to `CustomException`). Next, add the following class definition:

```
// This custom exception describes the details of the car-is-dead condition.
// (Remember, you can also simply extend Exception.)
public class CarIsDeadException : ApplicationException
{ }
```

As with any class, you are free to include any number of custom members that can be called within the catch block of the calling logic. You are also free to override any virtual members defined by your parent classes. For example, you could implement the `CarIsDeadException` by overriding the virtual `Message` property.

As well, rather than populating a data dictionary (via the `Data` property) when throwing the exception, the constructor allows the sender to pass in a timestamp and reason for the error. Finally, the time stamp data and cause of the error can be obtained using strongly typed properties.

```
public class CarIsDeadException : ApplicationException
{
    private string messageDetails = String.Empty;
    public DateTime ErrorTimeStamp {get; set;}
    public string CauseOfError {get; set;}

    public CarIsDeadException(){}
    public CarIsDeadException(string message,
        string cause, DateTime time)
    {
        messageDetails = message;
        CauseOfError = cause;
        ErrorTimeStamp = time;
    }

    // Override the Exception.Message property.
    public override string Message
    {
        get
        {
            return string.Format("Car Error Message: {0}", messageDetails);
        }
    }
}
```

Here, the `CarIsDeadException` class maintains a private field (`messageDetails`) that represents data regarding the current exception, which can be set using a custom constructor. Throwing this exception from the `Accelerate()` method is straightforward. Simply allocate, configure, and throw a `CarIsDeadException` type rather than a `System.Exception` (notice that in this case, you no longer need to fill the data collection manually).

```
// Throw the custom CarIsDeadException.
public void Accelerate(int delta)
{
    ...
    CarIsDeadException ex =
        new CarIsDeadException (string.Format("{0} has overheated!", PetName),
            "You have a lead foot", DateTime.Now);
    ex.HelpLink = "http://www.CarsRUs.com";
    throw ex;
    ...
}
```

To catch this incoming exception, your catch scope can now be updated to catch a specific `CarIsDeadException` type (however, given that `CarIsDeadException` “is-a” `System.Exception`, it is still permissible to catch a `System.Exception` as well).

```
static void Main(string[] args)
{
    Console.WriteLine("***** Fun with Custom Exceptions *****\n");
    Car myCar = new Car("Rusty", 90);

    try
    {
        // Trip exception.
        myCar.Accelerate(50);
    }
    catch (CarIsDeadException e)
    {
        Console.WriteLine(e.Message);
        Console.WriteLine(e.ErrorTimeStamp);
        Console.WriteLine(e.CauseOfError);
    }
    Console.ReadLine();
}
```

So, now that you understand the basic process of building a custom exception, you might wonder when you are required to do so. Typically, you only need to create custom exceptions when the error is tightly bound to the class issuing the error (for example, a custom file-centric class that throws a number of file-related errors, a `Car` class that throws a number of car-related errors, a data access object that throws errors regarding a particular database table, and so forth). In doing so, you provide the caller with the ability to handle numerous exceptions on a descriptive error-by-error basis.

Building Custom Exceptions, Take 2

The current `CarIsDeadException` type has overridden the virtual `System.Exception.Message` property in order to configure a custom error message and has supplied two custom properties to account for additional bits of data. In reality, however, you are not required to override the virtual `Message` property, as you could simply pass the incoming message to the parent’s constructor as follows:

```
public class CarIsDeadException : ApplicationException
{
    public DateTime ErrorTimeStamp { get; set; }
    public string CauseOfError { get; set; }

    public CarIsDeadException() { }

    // Feed message to parent constructor.
    public CarIsDeadException(string message, string cause, DateTime time)
        :base(message)
    {
        CauseOfError = cause;
        ErrorTimeStamp = time;
    }
}
```

Notice that this time you have *not* defined a string variable to represent the message and have *not* overridden the `Message` property. Rather, you are simply passing the parameter to your base class constructor. With this design, a custom exception class is little more than a uniquely named class deriving from `System.ApplicationException` (with additional properties if appropriate), devoid of any base class overrides.

Don't be surprised if most (if not all) of your custom exception classes follow this simple pattern. Many times, the role of a custom exception is not necessarily to provide additional functionality beyond what is inherited from the base classes but to supply a *strongly named type* that clearly identifies the nature of the error, so the client can provide different handler-logic for different types of exceptions.

Building Custom Exceptions, Take 3

If you want to build a truly prim-and-proper custom exception class, you would want to make sure your type adheres to .NET best practices. Specifically, this requires that your custom exception does the following:

- Derives from `Exception/ApplicationException`
- Is marked with the `[System.Serializable]` attribute
- Defines a default constructor
- Defines a constructor that sets the inherited `Message` property
- Defines a constructor to handle “inner exceptions”
- Defines a constructor to handle the serialization of your type

Now, based on your current background with .NET, you might have no experience regarding the role of attributes or object serialization, which is just fine. I'll address these topics later (see Chapter 15 for information on attributes and Chapter 20 for details on serialization services). However, to complete your examination of building custom exceptions, here is the final iteration of `CarIsDeadException`, which accounts for each of these special constructors (the other custom properties and constructors would be as shown in the example in “Building Custom Exceptions, Take 2”):

```
[Serializable]
public class CarIsDeadException : ApplicationException
{
    public CarIsDeadException() { }
    public CarIsDeadException(string message) : base( message ) { }
    public CarIsDeadException(string message,
                               System.Exception inner)
        : base( message, inner ) { }
    protected CarIsDeadException(
        System.Runtime.Serialization.SerializationInfo info,
        System.Runtime.Serialization.StreamingContext context)
        : base( info, context ) { }
    // Any additional custom properties, constructors and data members...
}
```

Given that building custom exceptions that adhere to .NET best practices really differ by only their name, you will be happy to know that Visual Studio provides a code snippet template named `Exception` (see Figure 7-1) that will autogenerate a new exception class that adheres to .NET best practices. (Recall from Chapter 2 that a code snippet can be activated by typing its name, which is `exception` in this case, and pressing the `Tab` key twice.)

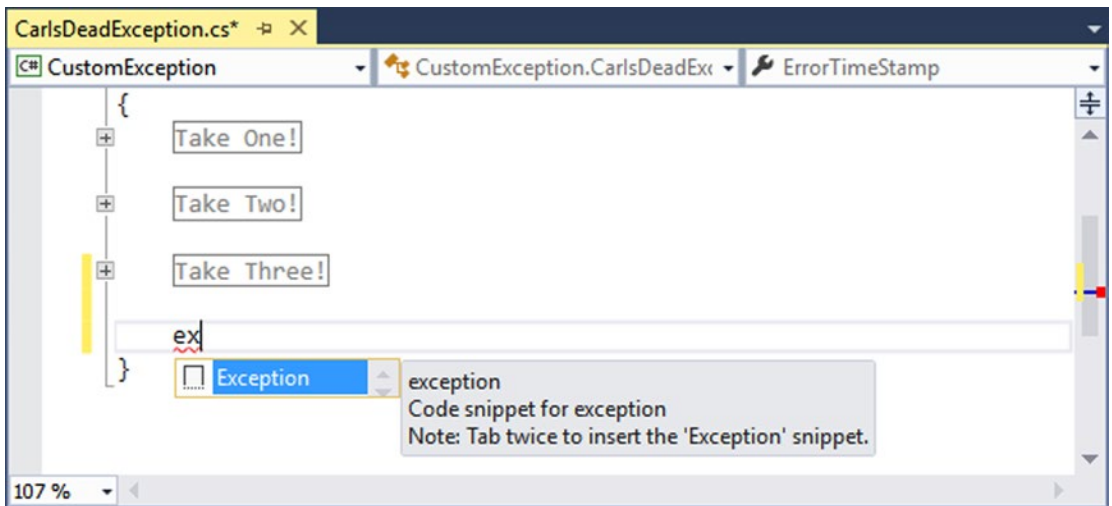

Figure 7-1. The *Exception* code snippet template

■ **Source Code** The CustomException project is included in the Chapter 7 subdirectory.

Processing Multiple Exceptions

In its simplest form, a try block has a single catch block. In reality, though, you often run into situations where the statements within a try block could trigger *numerous* possible exceptions. Create a new C# Console Application project named *ProcessMultipleExceptions*; add the *Car.cs*, *Radio.cs*, and *CarIsDeadException.cs* files from the previous CustomException example into the new project (via Project ► Add Existing Item); and update your namespace names accordingly.

Now, update the Car's *Accelerate()* method to also throw a predefined base class library *ArgumentOutOfRangeException* if you pass an invalid parameter (which you can assume is any value less than zero). Note the constructor of this exception class takes the name of the offending argument as the first string, followed by a message describing the error.

```
// Test for invalid argument before proceeding.
public void Accelerate(int delta)
{
    if(delta < 0)
        throw new
            ArgumentOutOfRangeException("delta", "Speed must be greater than zero!");
    ...
}
```

The catch logic could now specifically respond to each type of exception.

```
static void Main(string[] args)
{
    Console.WriteLine("***** Handling Multiple Exceptions *****\n");
    Car myCar = new Car("Rusty", 90);
    try
    {
        // Trip Arg out of range exception.
        myCar.Accelerate(-10);
    }
    catch (CarIsDeadException e)
    {
        Console.WriteLine(e.Message);
    }
    catch (ArgumentOutOfRangeException e)
    {
        Console.WriteLine(e.Message);
    }
    Console.ReadLine();
}
```

When you are authoring multiple catch blocks, you must be aware that when an exception is thrown, it will be processed by the first appropriate catch. To illustrate exactly what the “first appropriate” catch means, assume you retrofitted the previous logic with an additional catch scope that attempts to handle all exceptions beyond `CarIsDeadException` and `ArgumentOutOfRangeException` by catching a general `System.Exception` as follows:

```
// This code will not compile!
static void Main(string[] args)
{
    Console.WriteLine("***** Handling Multiple Exceptions *****\n");
    Car myCar = new Car("Rusty", 90);

    try
    {
        // Trigger an argument out of range exception.
        myCar.Accelerate(-10);
    }
    catch(Exception e)
    {
        // Process all other exceptions?
        Console.WriteLine(e.Message);
    }
    catch (CarIsDeadException e)
    {
        Console.WriteLine(e.Message);
    }
}
```



```

catch (ArgumentOutOfRangeException e)
{
    Console.WriteLine(e.Message);
}
Console.ReadLine();
}

```

This exception-handling logic generates compile-time errors. The problem is because the first catch block can handle *anything* derived from `System.Exception` (given the “is-a” relationship), including the `CarIsDeadException` and `ArgumentOutOfRangeException` types. Therefore, the final two catch blocks are unreachable!

The rule of thumb to keep in mind is to make sure your catch blocks are structured such that the first catch is the most specific exception (i.e., the most derived type in an exception-type inheritance chain), leaving the final catch for the most general (i.e., the base class of a given exception inheritance chain, in this case `System.Exception`).

Thus, if you want to define a catch block that will handle any errors beyond `CarIsDeadException` and `ArgumentOutOfRangeException`, you could write the following:

```

// This code compiles just fine.
static void Main(string[] args)
{
    Console.WriteLine("***** Handling Multiple Exceptions *****\n");
    Car myCar = new Car("Rusty", 90);
    try
    {
        // Trigger an argument out of range exception.
        myCar.Accelerate(-10);
    }
    catch (CarIsDeadException e)
    {
        Console.WriteLine(e.Message);
    }
    catch (ArgumentOutOfRangeException e)
    {
        Console.WriteLine(e.Message);
    }
    // This will catch any other exception
    // beyond CarIsDeadException or
    // ArgumentOutOfRangeException.
    catch (Exception e)
    {
        Console.WriteLine(e.Message);
    }
    Console.ReadLine();
}

```

■ **Note** Where at all possible, always favor catching specific exception classes, rather than a general `System.Exception`. Though it might appear to make life simple in the short term (you may think, “Ah! This catches all the other things I don’t care about.”), in the long term you could end up with strange runtime crashes, as a more serious error was not directly dealt with in your code. Remember, a final catch block that deals with `System.Exception` tends to be very general indeed.

General catch Statements

C# also supports a “general” catch scope that does not explicitly receive the exception object thrown by a given member.

```
// A generic catch.
static void Main(string[] args)
{
    Console.WriteLine("***** Handling Multiple Exceptions *****\n");
    Car myCar = new Car("Rusty", 90);
    try
    {
        myCar.Accelerate(90);
    }
    catch
    {
        Console.WriteLine("Something bad happened...");
    }
    Console.ReadLine();
}
```

Obviously, this is not the most informative way to handle exceptions since you have no way to obtain meaningful data about the error that occurred (such as the method name, call stack, or custom message). Nevertheless, C# does allow for such a construct, which can be helpful when you want to handle all errors in a general fashion.

Rethrowing Exceptions

When you catch an exception, it is permissible for the logic in a `try` block to *rethrow* the exception up the call stack to the previous caller. To do so, simply use the `throw` keyword within a `catch` block. This passes the exception up the chain of calling logic, which can be helpful if your catch block is only able to partially handle the error at hand.

```
// Passing the buck.
static void Main(string[] args)
{
    ...
    try
    {
        // Speed up car logic...
    }
}
```

```

catch(CarIsDeadException e)
{
    // Do any partial processing of this error and pass the buck.
    throw;
}
...
}

```

Be aware that in this example code, the ultimate receiver of `CarIsDeadException` is the CLR because it is the `Main()` method rethrowing the exception. Because of this, your end user is presented with a system-supplied error dialog box. Typically, you would only rethrow a partial handled exception to a caller that has the ability to handle the incoming exception more gracefully.

Notice as well that you are not explicitly rethrowing the `CarIsDeadException` object but rather making use of the `throw` keyword with no argument. You're not creating a new exception object; you're just rethrowing the original exception object (with all its original information). Doing so preserves the context of the original target.

Inner Exceptions

As you might suspect, it is entirely possible to trigger an exception at the time you are handling another exception. For example, assume you are handling a `CarIsDeadException` within a particular `catch` scope and during the process you attempt to record the stack trace to a file on your C: drive named `carErrors.txt` (you must specify you are using the `System.IO` namespace to gain access to these I/O-centric types).

```

catch(CarIsDeadException e)
{
    // Attempt to open a file named carErrors.txt on the C drive.
    FileStream fs = File.Open(@"C:\carErrors.txt", FileMode.Open);
    ...
}

```

Now, if the specified file is not located on your C: drive, the call to `File.Open()` results in a `FileNotFoundException`! Later in this book, you will learn all about the `System.IO` namespace where you'll discover how to programmatically determine whether a file exists on the hard drive before attempting to open the file in the first place (thereby avoiding the exception altogether). However, to stay focused on the topic of exceptions, assume the exception has been raised.

When you encounter an exception while processing another exception, best practice states that you should record the new exception object as an "inner exception" within a new object of the same type as the initial exception. (That was a mouthful!) The reason you need to allocate a new object of the exception being handled is that the only way to document an inner exception is via a constructor parameter. Consider the following code:

```

catch (CarIsDeadException e)
{
    try
    {
        FileStream fs = File.Open(@"C:\carErrors.txt", FileMode.Open);
        ...
    }
}

```

```

catch (Exception e2)
{
    // Throw an exception that records the new exception,
    // as well as the message of the first exception.
    throw new CarIsDeadException(e.Message, e2);
}
}

```

Notice, in this case, I have passed in the `FileNotFoundException` object as the second parameter to the `CarIsDeadException` constructor. After you have configured this new object, you throw it up the call stack to the next caller, which in this case would be the `Main()` method.

Given that there is no “next caller” after `Main()` to catch the exception, you would be again presented with an error dialog box. Much like the act of rethrowing an exception, recording inner exceptions is usually useful only when the caller has the ability to gracefully catch the exception in the first place. If this is the case, the caller’s catch logic can use the `InnerException` property to extract the details of the inner exception object.

The finally Block

A try/catch scope may also define an optional finally block. The purpose of a finally block is to ensure that a set of code statements will *always* execute, exception (of any type) or not. To illustrate, assume you want to always power down the car’s radio before exiting `Main()`, regardless of any handled exception.

```

static void Main(string[] args)
{
    Console.WriteLine("***** Handling Multiple Exceptions *****\n");
    Car myCar = new Car("Rusty", 90);
    myCar.CrankTunes(true);
    try
    {
        // Speed up car logic.
    }
    catch(CarIsDeadException e)
    {
        // Process CarIsDeadException.
    }
    catch(ArgumentOutOfRangeException e)
    {
        // Process ArgumentOutOfRangeException.
    }
    catch(Exception e)
    {
        // Process any other Exception.
    }
    finally
    {
        // This will always occur. Exception or not.
        myCar.CrankTunes(false);
    }
    Console.ReadLine();
}

```

If you did not include a `finally` block, the radio would not be turned off if an exception were encountered (which might or might not be problematic). In a more real-world scenario, when you need to dispose of objects, close a file, or detach from a database (or whatever), a `finally` block ensures a location for proper cleanup.

Exception Filters

The current release of C# introduces a new (and completely optional) clause that can be placed on a catch scope, via the `when` keyword. When you add this clause, you have the ability to ensure that the statements within a catch block are executed only if some condition in your code holds true. This expression must evaluate to a Boolean (true or false) and can be obtained by using a simple code statement in the `when` definition itself or by calling an additional method in your code. In a nutshell, this approach allows you to add “filters” to your exception logic.

First, assume you have added a few custom properties to your `CarIsDeadException`.

```
public class CarIsDeadException : ApplicationException
{
    ...
    // Custom members for our exception.
    public DateTime ErrorTimeStamp { get; set; }
    public string CauseOfError { get; set; }

    public CarIsDeadException(string message,
        string cause, DateTime time)
        : base(message)
    {
        CauseOfError = cause;
        ErrorTimeStamp = time;
    }
}
```

Also assume the `Accelerate()` method uses this new constructor when throwing the error.

```
CarIsDeadException ex =
    new CarIsDeadException(string.Format("{0} has overheated!", PetName),
        "You have a lead foot", DateTime.Now);
```

Now, consider the following modified exception logic. Here, I have added a *when clause* to the `CarIsDeadException` handler to ensure the catch block is never executed on a Friday (a contrived example, but who wants their automobile to break down on the weekend?). Notice that the single Boolean statement in the `when` clause must be wrapped in parentheses (also note you are now printing out a new message in this scope, which will output only when the `when` condition is true).

```
catch (CarIsDeadException e) when (e.ErrorTimeStamp.DayOfWeek != DayOfWeek.Friday)
{
    // This new line will only print if the when clause evaluates to true.
    Console.WriteLine("Catching car is dead!");

    Console.WriteLine(e.Message);
}
```

While the chances are you will simply have a catch clause for a given error under any condition, as you can see, the `new` when keyword allows you to get much more granular when responding to runtime errors.

Debugging Unhandled Exceptions Using Visual Studio

Do be aware that Visual Studio supplies a number of tools that help you debug unhandled custom exceptions. Again, assume you have increased the speed of a `Car` object beyond the maximum but this time did not bother to wrap your call within a `try` block.

```
Car myCar = new Car("Rusty", 90);
myCar.Accelerate(2000);
```

If you start a debugging session within Visual Studio (using the `Debug ▶ Start Debugging` menu selection), Visual Studio automatically breaks at the time the uncaught exception is thrown. Better yet, you are presented with a window (see Figure 7-2) displaying the value of the `Message` property.

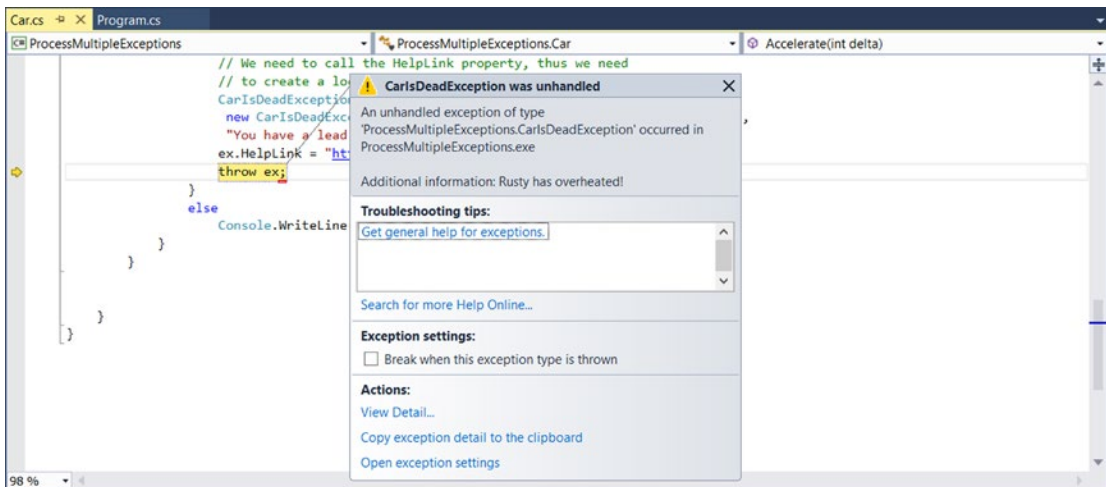

Figure 7-2. Debugging unhandled custom exceptions with Visual Studio

■ **Note** If you fail to handle an exception thrown by a method in the .NET base class libraries, the Visual Studio debugger breaks at the statement that called the offending method.

If you click the `View Detail` link, you will find the details regarding the state of the object (see Figure 7-3).

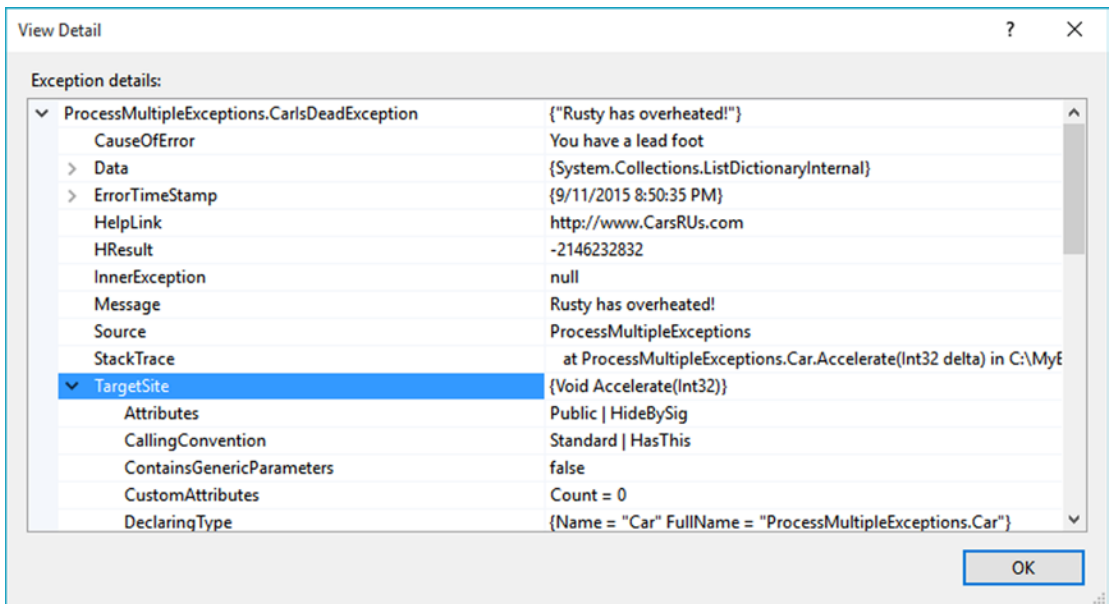

Figure 7-3. Viewing exception details

■ **Source Code** The ProcessMultipleExceptions project is included in the Chapter 7 subdirectory.

Summary

In this chapter, you examined the role of structured exception handling. When a method needs to send an error object to the caller, it will allocate, configure, and throw a specific `System.Exception`-derived type via the C# `throw` keyword. The caller is able to handle any possible incoming exceptions using the C# `catch` keyword and an optional `finally` scope. As shown, C# 6.0 now supports the ability to create exception filters using the optional `when` keyword.

When you are creating your own custom exceptions, you ultimately create a class type deriving from `System.ApplicationException`, which denotes an exception thrown from the currently executing application. In contrast, error objects deriving from `System.SystemException` represent critical (and fatal) errors thrown by the CLR. Last but not least, this chapter illustrated various tools within Visual Studio that can be used to create custom exceptions (according to .NET best practices) as well as debug exceptions.

CHAPTER 8



Working with Interfaces

This chapter builds upon your current understanding of object-oriented development by examining the topic of interface-based programming. Here you'll learn how to define and implement interfaces and come to understand the benefits of building types that support multiple behaviors. Along the way, you will also examine a number of related topics, such as obtaining interface references, explicit interface implementation, and the construction of interface hierarchies. You'll also examine a number of standard interfaces defined within the .NET base class libraries. As you will see, your custom classes and structures are free to implement these predefined interfaces to support a number of useful behaviors, such as object cloning, object enumeration, and object sorting.

Understanding Interface Types

To begin this chapter, allow me to provide a formal definition of the *interface type*. An interface is nothing more than a named set of *abstract members*. Recall from Chapter 6 that abstract methods are pure protocol in that they do not provide a default implementation. The specific members defined by an interface depend on the exact behavior it is modeling. Said another way, an interface expresses a *behavior* that a given class or structure may choose to support. Furthermore, as you will see in this chapter, a class or structure can support as many interfaces as necessary, thereby supporting (in essence) multiple behaviors.

As you might guess, the .NET base class libraries ship with numerous predefined interface types that are implemented by various classes and structures. For example, as you will see in Chapter 21, ADO.NET ships with multiple data providers that allow you to communicate with a particular database management system. Thus, under ADO.NET, you have numerous connection objects to choose from (`SqlConnection`, `OleDbConnection`, `OdbcConnection`, etc.). In addition, third-party database vendors (as well as numerous open source projects) provide .NET libraries to communicate with a wide number of other databases (MySQL, Oracle, etc.), all of which contain objects implementing these interfaces.

Regardless of the fact that each connection class has a unique name, is defined within a different namespace, and (in some cases) is bundled within a different assembly, all connection classes implement a common interface named `IDbConnection`.

```
// The IDbConnection interface defines a common
// set of members supported by all connection objects.
public interface IDbConnection : IDisposable
{
    // Methods
    IDbTransaction BeginTransaction();
    IDbTransaction BeginTransaction(IsolationLevel il);
    void ChangeDatabase(string databaseName);
    void Close();
}
```



```

    IDbCommand CreateCommand();
    void Open();
    // Properties
    string ConnectionString { get; set;}
    int ConnectionTimeout { get; }
    string Database { get; }
    ConnectionState State { get; }
}

```

■ **Note** By convention, .NET interfaces are prefixed with a capital letter *I*. When you are creating your own custom interfaces, it is considered a best practice to do the same.

Don't concern yourself with the details of what these members actually do at this point. Simply understand that the `IDbConnection` interface defines a set of members that are common to all ADO.NET connection classes. Given this, you are guaranteed that every connection object supports members such as `Open()`, `Close()`, `CreateCommand()`, and so forth. Furthermore, given that interface members are always abstract, each connection object is free to implement these methods in its own unique manner.

As you work through the remainder of this book, you'll be exposed to dozens of interfaces that ship with the .NET base class libraries. As you will see, these interfaces can be implemented on your own custom classes and structures to define types that integrate tightly within the framework. As well, once you understand the usefulness of the interface type, you will certainly find reasons to build your own.

Interface Types vs. Abstract Base Classes

Given your work in Chapter 6, the interface type might seem somewhat similar to an abstract base class. Recall that when a class is marked as abstract, it *may* define any number of abstract members to provide a polymorphic interface to all derived types. However, even when a class does define a set of abstract members, it is also free to define any number of constructors, field data, nonabstract members (with implementation), and so on. Interfaces, on the other hand, contain *only* member definitions.

The polymorphic interface established by an abstract parent class suffers from one major limitation in that *only derived types* support the members defined by the abstract parent. However, in larger software systems, it is common to develop multiple class hierarchies that have no common parent beyond `System.Object`. Given that abstract members in an abstract base class apply only to derived types, you have no way to configure types in different hierarchies to support the same polymorphic interface. By way of example, assume you have defined the following abstract class:

```

public abstract class CloneableType
{
    // Only derived types can support this
    // "polymorphic interface." Classes in other
    // hierarchies have no access to this abstract
    // member.
    public abstract object Clone();
}

```

Given this definition, only members that extend `CloneableType` are able to support the `Clone()` method. If you create a new set of classes that do not extend this base class, you can't gain this polymorphic interface. Also, you might recall that C# does not support multiple inheritance for classes. Therefore, if you wanted to create a `MiniVan` that is-a `Car` and is-a `CloneableType`, you are unable to do so.

```
// Nope! Multiple inheritance is not possible in C#
// for classes.
public class MiniVan : Car, CloneableType
{
}
```

As you might guess, interface types come to the rescue. After an interface has been defined, it can be implemented by any class or structure, in any hierarchy, and within any namespace or any assembly (written in any .NET programming language). As you can see, interfaces are *highly* polymorphic. Consider the standard .NET interface named `ICloneable`, defined in the `System` namespace. This interface defines a single method named `Clone()`:

```
public interface ICloneable
{
    object Clone();
}
```

If you examine the .NET Framework 4.6 SDK documentation, you'll find that a large number of seemingly unrelated types (`System.Array`, `System.Data.SqlClient.SqlConnection`, `System.OperatingSystem`, `System.String`, etc.) all implement this interface. Although these types have no common parent (other than `System.Object`), you can treat them polymorphically via the `ICloneable` interface type.

For example, if you had a method named `CloneMe()` that took an `ICloneable` interface parameter, you could pass this method any object that implements said interface. Consider the following simple `Program` class defined within a Console Application project named `ICloneableExample`:

```
class Program
{
    static void Main(string[] args)
    {
        Console.WriteLine("***** A First Look at Interfaces *****\n");

        // All of these classes support the ICloneable interface.
        string myStr = "Hello";
        OperatingSystem unixOS = new OperatingSystem(PlatformID.Unix, new Version());
        System.Data.SqlClient.SqlConnection sqlCnn =
            new System.Data.SqlClient.SqlConnection();

        // Therefore, they can all be passed into a method taking ICloneable.
        CloneMe(myStr);
        CloneMe(unixOS);
        CloneMe(sqlCnn);
        Console.ReadLine();
    }
}
```

```
private static void CloneMe(ICloneable c)
{
    // Clone whatever we get and print out the name.
    object theClone = c.Clone();
    Console.WriteLine("Your clone is a: {0}",
        theClone.GetType().Name);
}
}
```

When you run this application, the class name of each class prints to the console via the `GetType()` method you inherit from `System.Object`. As explained in Chapter 15, this method (and .NET reflection services) allow you to understand the composition of any type at runtime. In any case, the output of the previous program is shown next:

```
***** A First Look at Interfaces *****
```

```
Your clone is a: String
Your clone is a: OperatingSystem
Your clone is a: SqlConnection
```

■ **Source Code** The `ICloneableExample` project is located in the Chapter 8 subdirectory.

Another limitation of abstract base classes is that *each derived type* must contend with the set of abstract members and provide an implementation. To see this problem, recall the shapes hierarchy you defined in Chapter 6. Assume you defined a new abstract method in the `Shape` base class named `GetNumberOfPoints()`, which allows derived types to return the number of points required to render the shape.

```
abstract class Shape
{
    ...
    // Every derived class must now support this method!
    public abstract byte GetNumberOfPoints();
}
```

Clearly, the only class that has any points in the first place is `Hexagon`. However, with this update, *every* derived class (`Circle`, `Hexagon`, and `ThreeDCircle`) must now provide a concrete implementation of this function, even if it makes no sense to do so. Again, the interface type provides a solution. If you define an interface that represents the behavior of “having points,” you can simply plug it into the `Hexagon` type, leaving `Circle` and `ThreeDCircle` untouched.

Defining Custom Interfaces

Now that you better understand the overall role of interface types, let’s see an example of defining and implementing custom interfaces. To begin, create a new Console Application project named `CustomInterface`. Using the Project ► Add Existing Item menu option, insert the file (or files) containing

your shape type definitions (Shapes.cs in the book's solution code) created in Chapter 6 during the Shapes example. After you have done so, rename the namespace that defines your shape-centric types to CustomInterface (simply to avoid having to import namespace definitions in your new project).

```
namespace CustomInterface
{
    // Your shape types defined here...
}
```

Now, insert a new interface into your project named IPointy using the Project ► Add New Item menu option, as shown in Figure 8-1.

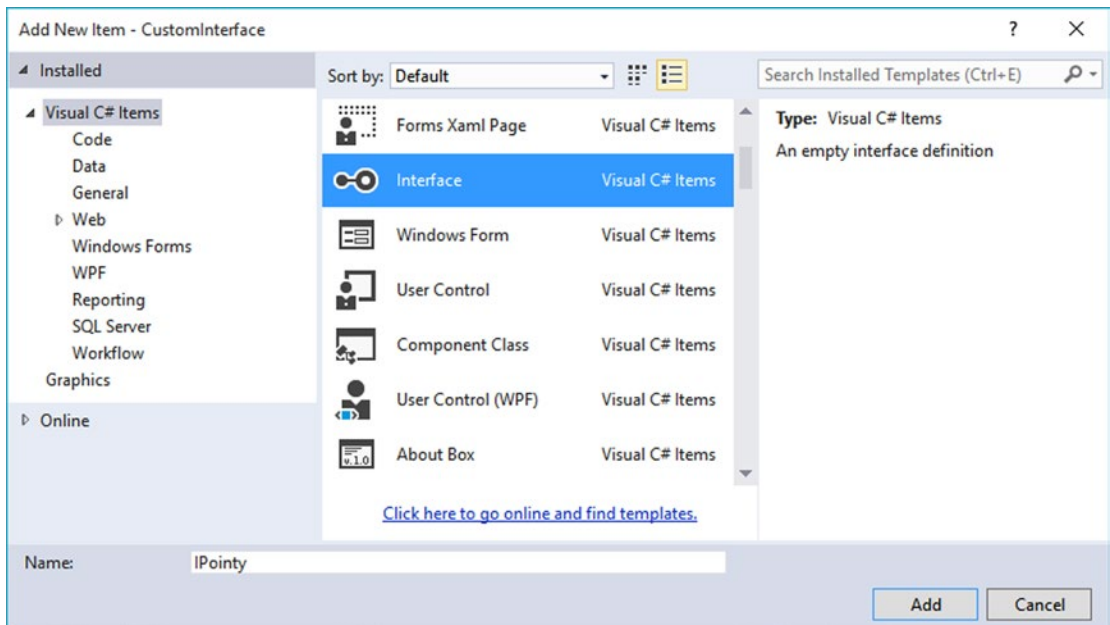

Figure 8-1. Interfaces, like classes, can be defined in any *.cs file

At a syntactic level, an interface is defined using the C# interface keyword. Unlike a class, interfaces never specify a base class (not even System.Object; however, as you will see later in this chapter, an interface can specify base interfaces). Moreover, the members of an interface never specify an access modifier (as all interface members are implicitly public and abstract). To get the ball rolling, here is a custom interface defined in C#:

```
// This interface defines the behavior of "having points."
public interface IPointy
{
    // Implicitly public and abstract.
    byte GetNumberOfPoints();
}
```

Remember that when you define interface members, you do not define an implementation scope for the members in question. Interfaces are pure protocol and, therefore, never define an implementation (that is up to the supporting class or structure). Hence, the following version of `IPointy` would result in various compiler errors:

// Ack! Errors abound!

```
public interface IPointy
{
    // Error! Interfaces cannot have data fields!
    public int numbOfPoints;

    // Error! Interfaces do not have constructors!
    public IPointy() { numbOfPoints = 0;}

    // Error! Interfaces don't provide an implementation of members!
    byte GetNumberOfPoints() { return numbOfPoints; }
}
```

In any case, this initial `IPointy` interface defines a single method. However, .NET interface types are also able to define any number of property prototypes. For example, let's update the `IPointy` interface to use a read-only property rather than a traditional accessor method.

```
// The pointy behavior as a read-only property.
public interface IPointy
{
    // A read-write property in an interface would look like:
    // retType PropName { get; set; }
    //
    // while a write-only property in an interface would be:
    // retType PropName { set; }

    byte Points { get; }
}
```

■ **Note** Interface types can also contain event (see Chapter 10) and indexer (see Chapter 11) definitions.

Interface types are quite useless on their own, as they are nothing more than a named collection of abstract members. For example, you can't allocate interface types as you would a class or structure.

```
// Ack! Illegal to allocate interface types.
static void Main(string[] args)
{
    IPointy p = new IPointy(); // Compiler error!
}
```

Interfaces do not bring much to the table until they are implemented by a class or structure. Here, `IPointy` is an interface that expresses the behavior of "having points." The idea is simple: some classes in the shapes hierarchy have points (such as the `Hexagon`), while others (such as the `Circle`) do not.

Implementing an Interface

When a class (or structure) chooses to extend its functionality by supporting interfaces, it does so using a comma-delimited list in the type definition. Be aware that the direct base class must be the first item listed after the colon operator. When your class type derives directly from `System.Object`, you are free to simply list the interface (or interfaces) supported by the class, as the `C#` compiler will extend your types from `System.Object` if you do not say otherwise. On a related note, given that structures always derive from `System.ValueType` (see Chapter 4), simply list each interface directly after the structure definition. Ponder the following examples:

```
// This class derives from System.Object and
// implements a single interface.
public class Pencil : IPointy
{...}

// This class also derives from System.Object
// and implements a single interface.
public class SwitchBlade : object, IPointy
{...}

// This class derives from a custom base class
// and implements a single interface.
public class Fork : Utensil, IPointy
{...}

// This struct implicitly derives from System.ValueType and
// implements two interfaces.
public struct PitchFork : ICloneable, IPointy
{...}
```

Understand that implementing an interface is an all-or-nothing proposition. The supporting type is not able to selectively choose which members it will implement. Given that the `IPointy` interface defines a single read-only property, this is not too much of a burden. However, if you are implementing an interface that defines ten members (such as the `IDbConnection` interface shown earlier), the type is now responsible for fleshing out the details of all ten abstract members.

For this example, insert a new class type named `Triangle` that is-a `Shape` and supports `IPointy`. Note that the implementation of the read-only `Points` property simply returns the correct number of points (3).

```
// New Shape derived class named Triangle.
class Triangle : Shape, IPointy
{
    public Triangle() { }
    public Triangle(string name) : base(name) { }
    public override void Draw()
    { Console.WriteLine("Drawing {0} the Triangle", PetName); }

    // IPointy implementation.
    public byte Points
    {
        get { return 3; }
    }
}
```

Now, update your existing Hexagon type to also support the IPointy interface type.

```
// Hexagon now implements IPointy.
class Hexagon : Shape, IPointy
{
    public Hexagon(){ }
    public Hexagon(string name) : base(name){ }
    public override void Draw()
    { Console.WriteLine("Drawing {0} the Hexagon", PetName); }

    // IPointy implementation.
    public byte Points
    {
        get { return 6; }
    }
}
```

To sum up the story so far, the Visual Studio class diagram shown in Figure 8-2 illustrates IPointy-compatible classes using the popular “lollipop” notation. Notice again that Circle and ThreeDCircle do not implement IPointy, as this behavior makes no sense for these particular classes.

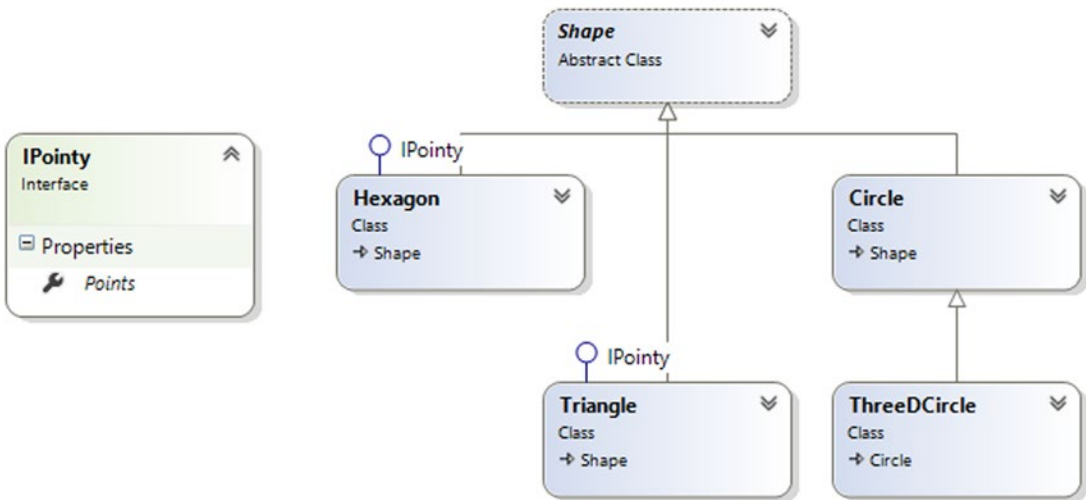

Figure 8-2. The shapes hierarchy, now with interfaces

Note To display or hide interface names in the class designer, right-click the interface icon and select the Collapse or Expand option.

Invoking Interface Members at the Object Level

Now that you have some classes that support the `IPointy` interface, the next question is how you interact with the new functionality. The most straightforward way to interact with functionality supplied by a given interface is to invoke the members directly from the object level (provided the interface members are not implemented explicitly; you can find more details later in the section “Explicit Interface Implementation”). For example, consider the following `Main()` method:

```
static void Main(string[] args)
{
    Console.WriteLine("***** Fun with Interfaces *****\n");
    // Call Points property defined by IPointy.
    Hexagon hex = new Hexagon();
    Console.WriteLine("Points: {0}", hex.Points);
    Console.ReadLine();
}
```

This approach works fine in this particular case, given that you are well aware that the `Hexagon` type has implemented the interface in question and, therefore, has a `Points` property. Other times, however, you might not be able to determine which interfaces are supported by a given type. For example, suppose you have an array containing 50 `Shape`-compatible types, only some of which support `IPointy`. Obviously, if you attempt to invoke the `Points` property on a type that has not implemented `IPointy`, you would receive an error. So, how can you dynamically determine whether a class or structure supports the correct interface?

One way to determine at runtime whether a type supports a specific interface is to use an explicit cast. If the type does not support the requested interface, you receive an `InvalidCastException`. To handle this possibility gracefully, use structured exception handling as in the following example:

```
static void Main(string[] args)
{
    ...
    // Catch a possible InvalidCastException.
    Circle c = new Circle("Lisa");
    IPointy itfPt = null;
    try
    {
        itfPt = (IPointy)c;
        Console.WriteLine(itfPt.Points);
    }
    catch (InvalidCastException e)
    {
        Console.WriteLine(e.Message);
    }
    Console.ReadLine();
}
```

While you could use `try/catch` logic and hope for the best, it would be ideal to determine which interfaces are supported before invoking the interface members in the first place. Let’s see two ways of doing so.

Obtaining Interface References: The as Keyword

You can determine whether a given type supports an interface by using the `as` keyword, introduced in Chapter 6. If the object can be treated as the specified interface, you are returned a reference to the interface in question. If not, you receive a null reference. Therefore, be sure to check against a null value before proceeding.

```
static void Main(string[] args)
{
    ...
    // Can we treat hex2 as IPointy?
    Hexagon hex2 = new Hexagon("Peter");
    IPointy itfPt2 = hex2 as IPointy;

    if(itfPt2 != null)
        Console.WriteLine("Points: {0}", itfPt2.Points);
    else
        Console.WriteLine("OOPS! Not pointy...");
    Console.ReadLine();
}
```

Notice that when you use the `as` keyword, you have no need to use `try/catch` logic, given that if the reference is not null, you know you are calling on a valid interface reference.

Obtaining Interface References: The is Keyword

You may also check for an implemented interface using the `is` keyword (also first discussed in Chapter 6). If the object in question is not compatible with the specified interface, you are returned the value `false`. On the other hand, if the type is compatible with the interface in question, you can safely call the members without needing to use `try/catch` logic.

To illustrate, assume you have an array of `Shape` types containing some members that implement `IPointy`. Notice how you are able to determine which items in the array support this interface using the `is` keyword, as shown in this retrofitted `Main()` method:

```
static void Main(string[] args)
{
    Console.WriteLine("***** Fun with Interfaces *****\n");

    // Make an array of Shapes.
    Shape[] myShapes = { new Hexagon(), new Circle(),
                        new Triangle("Joe"), new Circle("JoJo") } ;

    for(int i = 0; i < myShapes.Length; i++)
    {
        // Recall the Shape base class defines an abstract Draw()
        // member, so all shapes know how to draw themselves.
        myShapes[i].Draw();
    }
}
```

```

// Who's pointy?
if(myShapes[i] is IPointy)
    Console.WriteLine("-> Points: {0}", ((IPointy) myShapes[i]).Points);
else
    Console.WriteLine("-> {0}\s not pointy!", myShapes[i].PetName);
    Console.WriteLine();
}
Console.ReadLine();
}

```

The output is as follows:

```

***** Fun with Interfaces *****

```

```

Drawing NoName the Hexagon
-> Points: 6

```

```

Drawing NoName the Circle
-> NoName's not pointy!

```

```

Drawing Joe the Triangle
-> Points: 3

```

```

Drawing JoJo the Circle
-> JoJo's not pointy!

```

Interfaces As Parameters

Given that interfaces are valid .NET types, you may construct methods that take interfaces as parameters, as illustrated by the CloneMe() method earlier in this chapter. For the current example, assume you have defined another interface named IDraw3D.

```

// Models the ability to render a type in stunning 3D.
public interface IDraw3D
{
    void Draw3D();
}

```

Next, assume that two of your three shapes (ThreeDCircle and Hexagon) have been configured to support this new behavior.

```

// Circle supports IDraw3D.
class ThreeDCircle : Circle, IDraw3D
{
    ...
    public void Draw3D()
    { Console.WriteLine("Drawing Circle in 3D!"); }
}

```

```
// Hexagon supports IPointy and IDraw3D.
class Hexagon : Shape, IPointy, IDraw3D
{
...
    public void Draw3D()
    { Console.WriteLine("Drawing Hexagon in 3D!"); }
}
```

Figure 8-3 presents the updated Visual Studio class diagram.

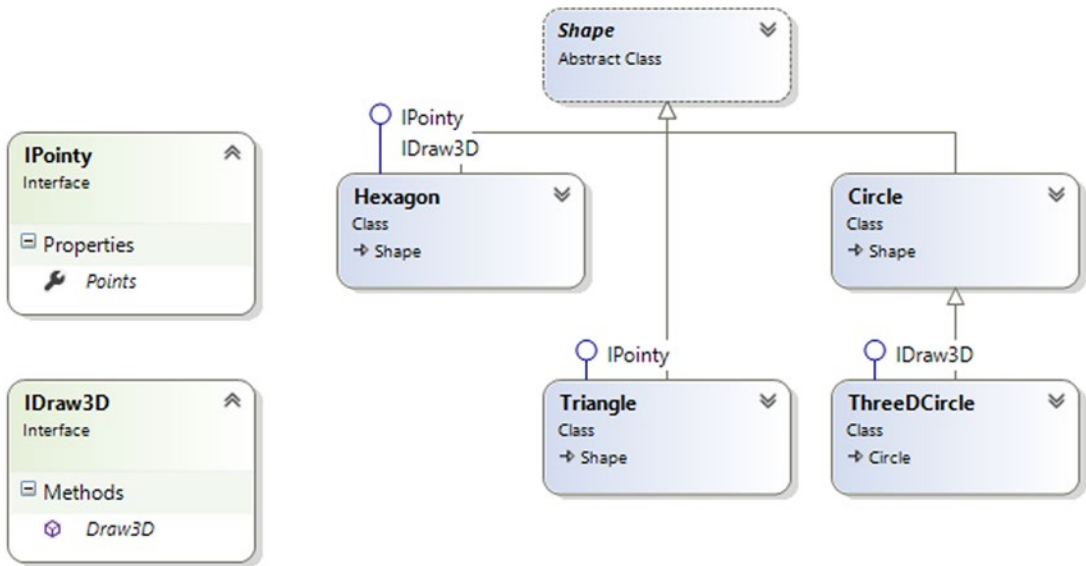

Figure 8-3. The updated shapes hierarchy

If you now define a method taking an **IDraw3D** interface as a parameter, you can effectively send in any object implementing **IDraw3D**. (If you attempt to pass in a type not supporting the necessary interface, you receive a compile-time error.) Consider the following method defined within your **Program** class:

```
// I'll draw anyone supporting IDraw3D.
static void DrawIn3D(IDraw3D itf3d)
{
    Console.WriteLine("-> Drawing IDraw3D compatible type");
    itf3d.Draw3D();
}
```

You could now test whether an item in the **Shape** array supports this new interface and, if so, pass it into the **DrawIn3D()** method for processing.

```

static void Main(string[] args)
{
    Console.WriteLine("***** Fun with Interfaces *****\n");
    Shape[] myShapes = { new Hexagon(), new Circle(),
                        new Triangle("Joe"), new Circle("JoJo") };
    for(int i = 0; i < myShapes.Length; i++)
    {
        ...
        // Can I draw you in 3D?
        if(myShapes[i] is IDraw3D)
            DrawIn3D((IDraw3D)myShapes[i]);
    }
}

```

Here is the output of the updated application. Notice that only the Hexagon object prints out in 3D, as the other members of the Shape array do not implement the IDraw3D interface.

```

***** Fun with Interfaces *****

Drawing NoName the Hexagon
-> Points: 6
-> Drawing IDraw3D compatible type
Drawing Hexagon in 3D!

Drawing NoName the Circle
-> NoName's not pointy!

Drawing Joe the Triangle
-> Points: 3

Drawing JoJo the Circle
-> JoJo's not pointy!

```

Interfaces As Return Values

Interfaces can also be used as method return values. For example, you could write a method that takes an array of Shape objects and returns a reference to the first item that supports IPointy.

```

// This method returns the first object in the
// array that implements IPointy.
static IPointy FindFirstPointyShape(Shape[] shapes)
{
    foreach (Shape s in shapes)
    {
        if (s is IPointy)
            return s as IPointy;
    }
    return null;
}

```

You could interact with this method as follows:

```
static void Main(string[] args)
{
    Console.WriteLine("***** Fun with Interfaces *****\n");
    // Make an array of Shapes.
    Shape[] myShapes = { new Hexagon(), new Circle(),
                        new Triangle("Joe"), new Circle("JoJo")};

    // Get first pointy item.
    // To be safe, you'd want to check firstPointyItem for null before proceeding.
    IPointy firstPointyItem = FindFirstPointyShape(myShapes);
    Console.WriteLine("The item has {0} points", firstPointyItem.Points);
    ...
}
```

Arrays of Interface Types

Recall that the same interface can be implemented by numerous types, even if they are not within the same class hierarchy and do not have a common parent class beyond `System.Object`. This can yield some powerful programming constructs. For example, assume you have developed three new class types within your current project that model kitchen utensils (via `Knife` and `Fork` classes) and another modeling gardening equipment (à la `PitchFork`). Consider Figure 8-4.

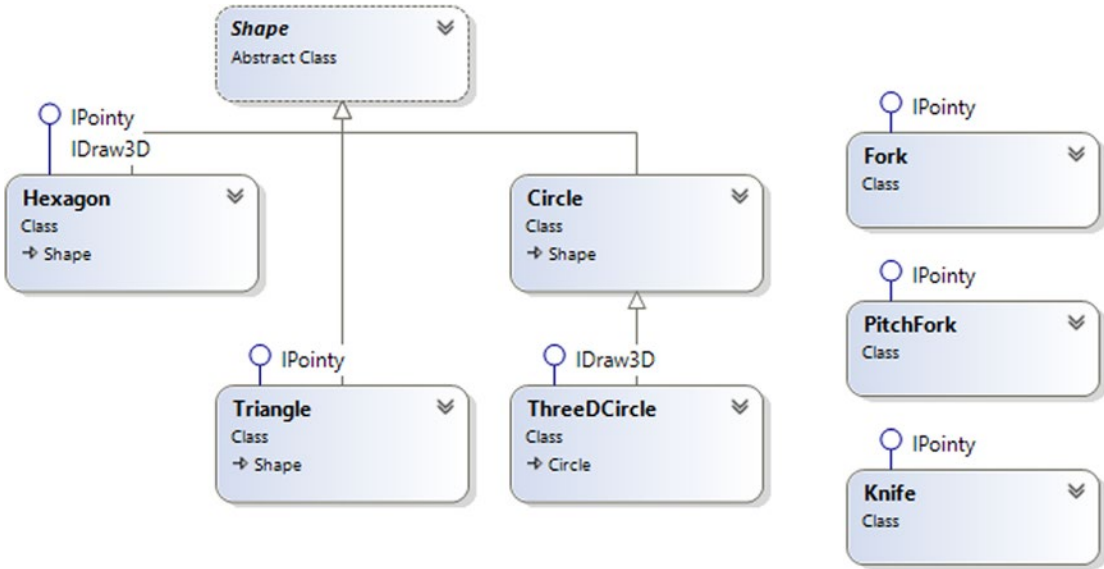

Figure 8-4. Recall that interfaces can be “plugged into” any type in any part of a class hierarchy

If you defined the `PitchFork`, `Fork`, and `Knife` types, you could now define an array of `IPointy`-compatible objects. Given that these members all support the same interface, you can iterate through the array and treat each item as an `IPointy`-compatible object, regardless of the overall diversity of the class hierarchies.

```
static void Main(string[] args)
{
    ...
    // This array can only contain types that
    // implement the IPointy interface.
    IPointy[] myPointyObjects = {new Hexagon(), new Knife(),
        new Triangle(), new Fork(), new PitchFork()};

    foreach(IPointy i in myPointyObjects)
        Console.WriteLine("Object has {0} points.", i.Points);
    Console.ReadLine();
}
```

Just to highlight the importance of this example, remember this: when you have an array of a given interface, the array can contain any class or structure that implements that interface.

■ **Source Code** The `CustomInterface` project is located in the `Chapter 8` subdirectory.

Implementing Interfaces Using Visual Studio

Although interface-based programming is a powerful technique, implementing interfaces may entail a healthy amount of typing. Given that interfaces are a named set of abstract members, you are required to type in the definition and implementation for *each* interface method on *each* type that supports the behavior. Therefore, if you want to support an interface that defines a total of five methods and three properties, you need to account for all eight members (or else you will receive compiler errors).

As you would hope, Visual Studio supports various tools that make the task of implementing interfaces less burdensome. By way of a simple test, insert a final class into your current project named `PointyTestClass`. When you add an interface such as `IPointy` (or any interface for that matter) to a class type, you might have noticed that when you complete typing the interface's name (or when you position the mouse cursor on the interface name in the code window), the first letter is underlined (formally termed a *smart tag*). When you click the smart tag, you will be presented with a drop-down list that allows you to implement the interface (see Figure 8-5).

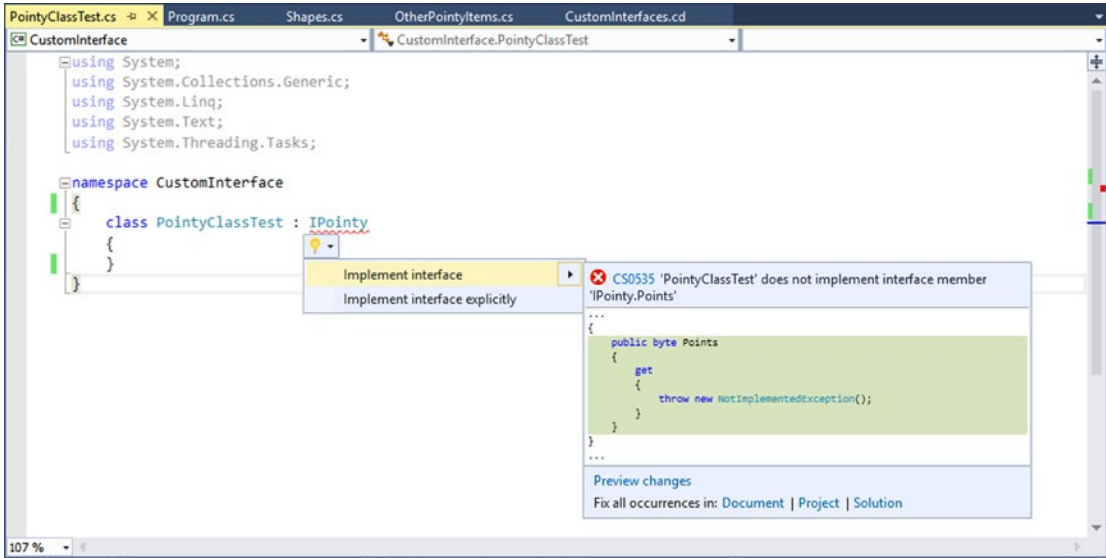

Figure 8-5. Implementing interfaces using Visual Studio

Notice you are presented with two options, the second of which (explicit interface implementation) will be examined in the next section. For the time being, select the first option and you'll see that Visual Studio has generated stub code for you to update (note that the default implementation throws a `System.NotImplementedException`, which can obviously be deleted).

```
namespace CustomInterface
{
    class PointyTestClass : IPointy
    {
        public byte Points
        {
            get { throw new NotImplementedException(); }
        }
    }
}
```

■ **Note** Visual Studio also supports extract interface refactoring, available from the Extract Interface option of the Quick Actions menu. This allows you to pull out a new interface definition from an existing class definition. For example, you might be halfway through writing a class when it dawns on you that you can generalize the behavior into an interface (and thereby open up the possibility of alternative implementations).

Explicit Interface Implementation

As shown earlier in this chapter, a class or structure can implement any number of interfaces. Given this, there is always the possibility you might implement interfaces that contain identical members and, therefore, have a name clash to contend with. To illustrate various manners in which you can resolve this issue, create a new Console Application project named `InterfaceNameClash`. Now design three interfaces that represent various locations to which an implementing type could render its output.

```
// Draw image to a form.
public interface IDrawToForm
{
    void Draw();
}

// Draw to buffer in memory.
public interface IDrawToMemory
{
    void Draw();
}

// Render to the printer.
public interface IDrawToPrinter
{
    void Draw();
}
```

Notice that each interface defines a method named `Draw()`, with the identical signature (which happen to be no arguments). If you now want to support each of these interfaces on a single class type named `Octagon`, the compiler would allow the following definition:

```
class Octagon : IDrawToForm, IDrawToMemory, IDrawToPrinter
{
    public void Draw()
    {
        // Shared drawing logic.
        Console.WriteLine("Drawing the Octagon...");
    }
}
```

Although the code compiles cleanly, you do have a possible problem. Simply put, providing a single implementation of the `Draw()` method does not allow you to take unique courses of action based on which interface is obtained from an `Octagon` object. For example, the following code will invoke the same `Draw()` method, regardless of which interface you obtain:

```
static void Main(string[] args)
{
    Console.WriteLine("***** Fun with Interface Name Clashes *****\n");
    // All of these invocations call the
    // same Draw() method!
    Octagon oct = new Octagon();
```



```

IDrawToForm itfForm = (IDrawToForm)oct;
itfForm.Draw();

IDrawToPrinter itfPriner = (IDrawToPrinter)oct;
itfPriner.Draw();

IDrawToMemory itfMemory = (IDrawToMemory)oct;
itfMemory.Draw();

Console.ReadLine();
}

```

Clearly, the sort of code required to render the image to a window is quite different from the code needed to render the image to a networked printer or a region of memory. When you implement several interfaces that have identical members, you can resolve this sort of name clash using *explicit interface implementation* syntax. Consider the following update to the Octagon type:

```

class Octagon : IDrawToForm, IDrawToMemory, IDrawToPrinter
{
    // Explicitly bind Draw() implementations
    // to a given interface.
    void IDrawToForm.Draw()
    {
        Console.WriteLine("Drawing to form...");
    }
    void IDrawToMemory.Draw()
    {
        Console.WriteLine("Drawing to memory...");
    }
    void IDrawToPrinter.Draw()
    {
        Console.WriteLine("Drawing to a printer...");
    }
}

```

As you can see, when explicitly implementing an interface member, the general pattern breaks down to this:

```
returnType InterfaceName.MethodName(params){}
```

Note that when using this syntax, you do not supply an access modifier; explicitly implemented members are automatically private. For example, the following is illegal syntax:

```

// Error! No access modifier!
public void IDrawToForm.Draw()
{
    Console.WriteLine("Drawing to form...");
}

```

Because explicitly implemented members are always implicitly private, these members are no longer available from the object level. In fact, if you were to apply the dot operator to an `Octagon` type, you would find that IntelliSense does not show you any of the `Draw()` members. As expected, you must use explicit casting to access the required functionality. Here's an example:

```
static void Main(string[] args)
{
    Console.WriteLine("***** Fun with Interface Name Clashes *****\n");
    Octagon oct = new Octagon();

    // We now must use casting to access the Draw()
    // members.
    IDrawToForm itfForm = (IDrawToForm)oct;
    itfForm.Draw();

    // Shorthand notation if you don't need
    // the interface variable for later use.
    ((IDrawToPrinter)oct).Draw();

    // Could also use the "is" keyword.
    if(oct is IDrawToMemory)
        ((IDrawToMemory)oct).Draw();

    Console.ReadLine();
}
```

While this syntax is quite helpful when you need to resolve name clashes, you can use explicit interface implementation simply to hide more “advanced” members from the object level. In this way, when the object user applies the dot operator, the user will see only a subset of the type’s overall functionality. However, those who require the more advanced behaviors can extract the desired interface via an explicit cast.

■ **Source Code** The `InterfaceNameClash` project is located in the [Chapter 8](#) subdirectory.

Designing Interface Hierarchies

Interfaces can be arranged in an interface hierarchy. Like a class hierarchy, when an interface extends an existing interface, it inherits the abstract members defined by the parent (or parents). Of course, unlike class-based inheritance, derived interfaces never inherit true implementation. Rather, a derived interface simply extends its own definition with additional abstract members.

Interface hierarchies can be useful when you want to extend the functionality of an existing interface without breaking existing code bases. To illustrate, create a new Console Application project named `InterfaceHierarchy`. Now, let’s design a new set of rendering-centric interfaces such that `IDrawable` is the root of the family tree.

```
public interface IDrawable
{
    void Draw();
}
```

Given that `IDrawable` defines a basic drawing behavior, you could now create a derived interface that extends this interface with the ability to render in modified formats. Here's an example:

```
public interface IAdvancedDraw : IDrawable
{
    void DrawInBoundingBox(int top, int left, int bottom, int right);
    void DrawUpsideDown();
}
```

Given this design, if a class were to implement `IAdvancedDraw`, it would now be required to implement every member defined up the chain of inheritance (specifically, the `Draw()`, `DrawInBoundingBox()`, and `DrawUpsideDown()` methods).

```
public class BitmapImage : IAdvancedDraw
{
    public void Draw()
    {
        Console.WriteLine("Drawing...");
    }

    public void DrawInBoundingBox(int top, int left, int bottom, int right)
    {
        Console.WriteLine("Drawing in a box...");
    }

    public void DrawUpsideDown()
    {
        Console.WriteLine("Drawing upside down!");
    }
}
```

Now, when you use the `BitmapImage`, you are able to invoke each method at the object level (as they are all public), as well as extract a reference to each supported interface explicitly via casting.

```
static void Main(string[] args)
{
    Console.WriteLine("***** Simple Interface Hierarchy *****");

    // Call from object level.
    BitmapImage myBitmap = new BitmapImage();
    myBitmap.Draw();
    myBitmap.DrawInBoundingBox(10, 10, 100, 150);
    myBitmap.DrawUpsideDown();

    // Get IAdvancedDraw explicitly.
    IAdvancedDraw iAdvDraw = myBitmap as IAdvancedDraw;
    if(iAdvDraw != null)
        iAdvDraw.DrawUpsideDown();
    Console.ReadLine();
}
```

■ **Source Code** The InterfaceHierarchy project is located in the Chapter 8 subdirectory.

Multiple Inheritance with Interface Types

Unlike class types, an interface can extend multiple base interfaces, allowing you to design some powerful and flexible abstractions. Create a new Console Application project named `MIInterfaceHierarchy`. Here is another collection of interfaces that model various rendering and shape abstractions. Notice that the `IShape` interface is extending both `IDrawable` and `IPrintable`.

```
// Multiple inheritance for interface types is a-okay.
interface IDrawable
{
    void Draw();
}

interface IPrintable
{
    void Print();
    void Draw(); // <-- Note possible name clash here!
}

// Multiple interface inheritance. OK!
interface IShape : IDrawable, IPrintable
{
    int GetNumberOfSides();
}
```

Figure 8-6 illustrates the current interface hierarchy.



Figure 8-6. Unlike classes, interfaces can extend multiple interface types

At this point, the million dollar question is, if you have a class supporting `IShape`, how many methods will it be required to implement? The answer: it depends. If you want to provide a simple implementation of the `Draw()` method, you need provide only three members, as shown in the following `Rectangle` type:

```
class Rectangle : IShape
{
    public int GetNumberOfSides()
    { return 4; }

    public void Draw()
    { Console.WriteLine("Drawing..."); }

    public void Print()
    { Console.WriteLine("Printing..."); }
}
```

If you'd rather have specific implementations for each `Draw()` method (which in this case would make the most sense), you can resolve the name clash using explicit interface implementation, as shown in the following `Square` type:

```
class Square : IShape
{
    // Using explicit implementation to handle member name clash.
    void IPrintable.Draw()
    {
        // Draw to printer ...
    }
    void IDrawable.Draw()
    {
        // Draw to screen ...
    }
    public void Print()
    {
        // Print ...
    }

    public int GetNumberOfSides()
    { return 4; }
}
```

Ideally, at this point you feel more comfortable with the process of defining and implementing custom interfaces using the `C#` syntax. To be honest, interface-based programming can take a while to get comfortable with, so if you are in fact still scratching your head just a bit, this is a perfectly normal reaction.

Do be aware, however, that interfaces are a fundamental aspect of the `.NET` Framework. Regardless of the type of application you are developing (web-based, desktop GUIs, data-access libraries, etc.), working with interfaces will be part of the process. To summarize the story thus far, remember that interfaces can be extremely useful when

- You have a single hierarchy where only a subset of the derived types supports a common behavior.
- You need to model a common behavior that is found across multiple hierarchies with no common parent class beyond `System.Object`.

Now that you have drilled into the specifics of building and implementing custom interfaces, the remainder of this chapter examines a number of predefined interfaces contained within the .NET base class libraries. As you will see, you can implement standard .NET interfaces on your custom types to ensure they integrate into the framework seamlessly.

■ **Source Code** The `MIInterfaceHierarchy` project is located in the Chapter 8 subdirectory.

The IEnumerable and IEnumerator Interfaces

To begin examining the process of implementing existing .NET interfaces, let's first look at the role of `IEnumerable` and `IEnumerator`. Recall that C# supports a keyword named `foreach` that allows you to iterate over the contents of any array type.

```
// Iterate over an array of items.
int[] myArrayOfInts = {10, 20, 30, 40};

foreach(int i in myArrayOfInts)
{
    Console.WriteLine(i);
}
```

While it might seem that only array types can use this construct, the truth of the matter is any type supporting a method named `GetEnumerator()` can be evaluated by the `foreach` construct. To illustrate, begin by creating a new Console Application project named `CustomEnumerator`. Next, add the `Car.cs` and `Radio.cs` files defined in the `SimpleException` example of Chapter 7 (via the Project ► Add Existing Item menu option).

■ **Note** You might want to rename the namespace containing the `Car` and `Radio` types to `CustomEnumerator` to avoid having to import the `CustomException` namespace within this new project.

Now, insert a new class named `Garage` that stores a set of `Car` objects within a `System.Array`.

```
// Garage contains a set of Car objects.
public class Garage
{
    private Car[] carArray = new Car[4];

    // Fill with some Car objects upon startup.
    public Garage()
    {
        carArray[0] = new Car("Rusty", 30);
        carArray[1] = new Car("Clunker", 55);
        carArray[2] = new Car("Zippy", 30);
        carArray[3] = new Car("Fred", 30);
    }
}
```

Ideally, it would be convenient to iterate over the `Garage` object's subitems using the `foreach` construct, just like an array of data values.

```
// This seems reasonable ...
public class Program
{
    static void Main(string[] args)
    {
        Console.WriteLine("***** Fun with IEnumerable / IEnumerator *****\n");
        Garage carLot = new Garage();

        // Hand over each car in the collection?
        foreach (Car c in carLot)
        {
            Console.WriteLine("{0} is going {1} MPH",
                c.PetName, c.CurrentSpeed);
        }
        Console.ReadLine();
    }
}
```

Sadly, the compiler informs you that the `Garage` class does not implement a method named `GetEnumerator()`. This method is formalized by the `IEnumerable` interface, which is found lurking within the `System.Collections` namespace.

■ **Note** In Chapter 9, you will learn about the role of generics and the `System.Collections.Generic` namespace. As you will see, this namespace contains generic versions of `IEnumerable/IEnumerator` that provide a more type-safe way to iterate over items.

Classes or structures that support this behavior advertise that they are able to expose contained items to the caller (in this example, the `foreach` keyword itself). Here is the definition of this standard .NET interface:

```
// This interface informs the caller
// that the object's items can be enumerated.
public interface IEnumerable
{
    IEnumerator GetEnumerator();
}
```

As you can see, the `GetEnumerator()` method returns a reference to yet another interface named `System.Collections.IEnumerator`. This interface provides the infrastructure to allow the caller to traverse the internal objects contained by the `IEnumerable`-compatible container.

```
// This interface allows the caller to
// obtain a container's items.
public interface IEnumerator
```

```

{
    bool MoveNext ();           // Advance the internal position of the cursor.
    object Current { get; }    // Get the current item (read-only property).
    void Reset ();             // Reset the cursor before the first member.
}

```

If you want to update the `Garage` type to support these interfaces, you could take the long road and implement each method manually. While you are certainly free to provide customized versions of `GetEnumerator()`, `MoveNext()`, `Current`, and `Reset()`, there is a simpler way. As the `System.Array` type (as well as many other collection classes) already implements `IEnumerable` and `IEnumerator`, you can simply delegate the request to the `System.Array` as follows (note you will need to import the `System.Collections` namespace into your code file):

```

using System.Collections;
...
public class Garage : IEnumerable
{
    // System.Array already implements IEnumerator!
    private Car[] carArray = new Car[4];

    public Garage()
    {
        carArray[0] = new Car("FeeFee", 200);
        carArray[1] = new Car("Clunker", 90);
        carArray[2] = new Car("Zippy", 30);
        carArray[3] = new Car("Fred", 30);
    }

    public IEnumerator GetEnumerator()
    {
        // Return the array object's IEnumerator.
        return carArray.GetEnumerator();
    }
}

```

After you have updated your `Garage` type, you can safely use the type within the C# `foreach` construct. Furthermore, given that the `GetEnumerator()` method has been defined publicly, the object user could also interact with the `IEnumerator` type.

```

// Manually work with IEnumerator.
IEnumerator i = carLot.GetEnumerator();
i.MoveNext();
Car myCar = (Car)i.Current;
Console.WriteLine("{0} is going {1} MPH", myCar.PetName, myCar.CurrentSpeed);

```

However, if you prefer to hide the functionality of `IEnumerable` from the object level, simply make use of explicit interface implementation.

```

IEnumerator IEnumerable.GetEnumerator()
{
    // Return the array object's IEnumerator.
    return carArray.GetEnumerator();
}

```

By doing so, the casual object user will not find the `Garage`'s `GetEnumerator()` method, while the `foreach` construct will obtain the interface in the background when necessary.

■ **Source Code** The `CustomEnumerator` project is located in the Chapter 8 subdirectory.

Building Iterator Methods with the `yield` Keyword

There's an alternative way to build types that work with the `foreach` loop via *iterators*. Simply put, an *iterator* is a member that specifies how a container's internal items should be returned when processed by `foreach`. To illustrate, create a new Console Application project named `CustomEnumeratorWithYield` and insert the `Car`, `Radio`, and `Garage` types from the previous example (again, renaming your namespace definitions to the current project if you like). Now, retrofit the current `Garage` type as follows:

```
public class Garage : IEnumerable
{
    private Car[] carArray = new Car[4];
    ...
    // Iterator method.

    public IEnumerator GetEnumerator()
    {
        foreach (Car c in carArray)
        {
            yield return c;
        }
    }
}
```

Notice that this implementation of `GetEnumerator()` iterates over the subitems using internal `foreach` logic and returns each `Car` to the caller using the `yield return` syntax. The `yield` keyword is used to specify the value (or values) to be returned to the caller's `foreach` construct. When the `yield return` statement is reached, the current location in the container is stored, and execution is restarted from this location the next time the iterator is called.

Iterator methods are not required to use the `foreach` keyword to return its contents. It is also permissible to define this iterator method as follows:

```
public IEnumerator GetEnumerator()
{
    yield return carArray[0];
    yield return carArray[1];
    yield return carArray[2];
    yield return carArray[3];
}
```

In this implementation, notice that the `GetEnumerator()` method is explicitly returning a new value to the caller with each pass through. Doing so for this example makes little sense, given that if you were to add more objects to the `carArray` member variable, your `GetEnumerator()` method would now be out of sync. Nevertheless, this syntax can be useful when you want to return local data from a method for processing by the `foreach` syntax.

Building a Named Iterator

It is also interesting to note that the `yield` keyword can technically be used within any method, regardless of its name. These methods (which are technically called *named iterators*) are also unique in that they can take any number of arguments. When building a named iterator, be aware that the method will return the `IEnumerable` interface, rather than the expected `IEnumerator`-compatible type. To illustrate, you could add the following method to the `Garage` type:

```
public IEnumerable GetTheCars(bool ReturnReversed)
{
    // Return the items in reverse.
    if (ReturnReversed)
    {
        for (int i = carArray.Length; i != 0; i--)
        {
            yield return carArray[i-1];
        }
    }
    else
    {
        // Return the items as placed in the array.
        foreach (Car c in carArray)
        {
            yield return c;
        }
    }
}
```

Notice that the new method allows the caller to obtain the subitems in sequential order, as well as in reverse order, if the incoming parameter has the value `true`. You could now interact with your new method as follows:

```
static void Main(string[] args)
{
    Console.WriteLine("***** Fun with the Yield Keyword *****\n");
    Garage carLot = new Garage();

    // Get items using GetEnumerator().
    foreach (Car c in carLot)
    {
        Console.WriteLine("{0} is going {1} MPH",
            c.PetName, c.CurrentSpeed);
    }

    Console.WriteLine();

    // Get items (in reverse!) using named iterator.
    foreach (Car c in carLot.GetTheCars(true))
    {
        Console.WriteLine("{0} is going {1} MPH",
            c.PetName, c.CurrentSpeed);
    }
    Console.ReadLine();
}
```

As you might agree, named iterators are helpful constructs, in that a single custom container can define multiple ways to request the returned set.

So, to wrap up your look at building enumerable objects, remember that for your custom types to work with the C# `foreach` keyword, the container must define a method named `GetEnumerator()`, which has been formalized by the `IEnumerable` interface type. The implementation of this method is typically achieved by simply delegating it to the internal member that is holding onto the subobjects; however, it is also possible to use the `yield return` syntax to provide multiple “named iterator” methods.

■ **Source Code** The `CustomEnumeratorWithYield` project is located in the [Chapter 8](#) subdirectory.

The `ICloneable` Interface

As you might recall from [Chapter 6](#), `System.Object` defines a method named `MemberwiseClone()`. This method is used to obtain a *shallow copy* of the current object. Object users do not call this method directly, as it is protected. However, a given object may call this method itself during the *cloning* process. To illustrate, create a new Console Application project named `CloneablePoint` that defines a class named `Point`.

```
// A class named Point.
public class Point
{
    public int X {get; set;}
    public int Y {get; set;}

    public Point(int xPos, int yPos) { X = xPos; Y = yPos;}
    public Point(){ }

    // Override Object.ToString().
    public override string ToString()
    { return string.Format("X = {0}; Y = {1}", X, Y ); }
}
```

Given what you already know about reference types and value types (see [Chapter 4](#)), you are aware that if you assign one reference variable to another, you have two references pointing to the same object in memory. Thus, the following assignment operation results in two references to the same `Point` object on the heap; modifications using either reference affect the same object on the heap:

```
static void Main(string[] args)
{
    Console.WriteLine("***** Fun with Object Cloning *****\n");
    // Two references to same object!
    Point p1 = new Point(50, 50);
    Point p2 = p1;
    p2.X = 0;
    Console.WriteLine(p1);
    Console.WriteLine(p2);
    Console.ReadLine();
}
```

When you want to give your custom type the ability to return an identical copy of itself to the caller, you may implement the standard `ICloneable` interface. As shown at the start of this chapter, this type defines a single method named `Clone()`.

```
public interface ICloneable
{
    object Clone();
}
```

Obviously, the implementation of the `Clone()` method varies among your classes. However, the basic functionality tends to be the same: copy the values of your member variables into a new object instance of the same type and return it to the user. To illustrate, ponder the following update to the `Point` class:

```
// The Point now supports "clone-ability."
public class Point : ICloneable
{
    public int X { get; set; }
    public int Y { get; set; }

    public Point(int xPos, int yPos) { X = xPos; Y = yPos; }
    public Point() { }

    // Override Object.ToString().
    public override string ToString()
    { return string.Format("X = {0}; Y = {1}", X, Y); }

    // Return a copy of the current object.
    public object Clone()
    { return new Point(this.X, this.Y); }
}
```

In this way, you can create exact stand-alone copies of the `Point` type, as illustrated by the following code:

```
static void Main(string[] args)
{
    Console.WriteLine("***** Fun with Object Cloning *****\n");
    // Notice Clone() returns a plain object type.
    // You must perform an explicit cast to obtain the derived type.
    Point p3 = new Point(100, 100);
    Point p4 = (Point)p3.Clone();

    // Change p4.X (which will not change p3.X).
    p4.X = 0;

    // Print each object.
    Console.WriteLine(p3);
    Console.WriteLine(p4);
    Console.ReadLine();
}
```

While the current implementation of `Point` fits the bill, you can streamline things just a bit. Because the `Point` type does not contain any internal reference type variables, you could simplify the implementation of the `Clone()` method as follows:

```
public object Clone()
{
    // Copy each field of the Point member by member.
    return this.MemberwiseClone();
}
```

Be aware, however, that if the `Point` did contain any reference type member variables, `MemberwiseClone()` would copy the references to those objects (i.e., a *shallow copy*). If you want to support a true *deep copy*, you will need to create a new instance of any reference type variables during the cloning process. Let's see an example next.

A More Elaborate Cloning Example

Now assume the `Point` class contains a reference type member variable of type `PointDescription`. This class maintains a point's friendly name as well as an identification number expressed as a `System.Guid` (a globally unique identifier [GUID] is a statistically unique 128-bit number). Here is the implementation:

```
// This class describes a point.
public class PointDescription
{
    public string PetName {get; set;}
    public Guid PointID {get; set;}

    public PointDescription()
    {
        PetName = "No-name";
        PointID = Guid.NewGuid();
    }
}
```

The initial updates to the `Point` class itself included modifying `ToString()` to account for these new bits of state data, as well as defining and creating the `PointDescription` reference type. To allow the outside world to establish a pet name for the `Point`, you also update the arguments passed into the overloaded constructor.

```
public class Point : ICloneable
{
    public int X { get; set; }
    public int Y { get; set; }
    public PointDescription desc = new PointDescription();

    public Point(int xPos, int yPos, string petName)
    {
        X = xPos; Y = yPos;
        desc.PetName = petName;
    }
}
```

```

public Point(int xPos, int yPos)
{
    X = xPos; Y = yPos;
}
public Point() { }

// Override Object.ToString().
public override string ToString()
{
    return string.Format("X = {0}; Y = {1}; Name = {2};\nID = {3}\n",
        X, Y, desc.PetName, desc.PointID);
}

// Return a copy of the current object.
public object Clone()
{ return this.MemberwiseClone(); }
}

```

Notice that you did not yet update your `Clone()` method. Therefore, when the object user asks for a clone using the current implementation, a shallow (member-by-member) copy is achieved. To illustrate, assume you have updated `Main()` as follows:

```

static void Main(string[] args)
{
    Console.WriteLine("***** Fun with Object Cloning *****\n");
    Console.WriteLine("Cloned p3 and stored new Point in p4");
    Point p3 = new Point(100, 100, "Jane");
    Point p4 = (Point)p3.Clone();

    Console.WriteLine("Before modification:");
    Console.WriteLine("p3: {0}", p3);
    Console.WriteLine("p4: {0}", p4);
    p4.desc.PetName = "My new Point";
    p4.X = 9;

    Console.WriteLine("\nChanged p4.desc.petName and p4.X");
    Console.WriteLine("After modification:");
    Console.WriteLine("p3: {0}", p3);
    Console.WriteLine("p4: {0}", p4);
    Console.ReadLine();
}

```

Notice in the following output that while the value types have indeed been changed, the internal reference types maintain the same values, as they are “pointing” to the same objects in memory (specifically, note that the pet name for both objects is now “My new Point”).

```
***** Fun with Object Cloning *****

Cloned p3 and stored new Point in p4
Before modification:
p3: X = 100; Y = 100; Name = Jane;
ID = 133d66a7-0837-4bd7-95c6-b22ab0434509

p4: X = 100; Y = 100; Name = Jane;
ID = 133d66a7-0837-4bd7-95c6-b22ab0434509

Changed p4.desc.petName and p4.X
After modification:
p3: X = 100; Y = 100; Name = My new Point;
ID = 133d66a7-0837-4bd7-95c6-b22ab0434509

p4: X = 9; Y = 100; Name = My new Point;
ID = 133d66a7-0837-4bd7-95c6-b22ab0434509
```

To have your Clone() method make a complete deep copy of the internal reference types, you need to configure the object returned by MemberwiseClone() to account for the current point’s name (the System.Guid type is in fact a structure, so the numerical data is indeed copied). Here is one possible implementation:

```
// Now we need to adjust for the PointDescription member.
public object Clone()
{
    // First get a shallow copy.
    Point newPoint = (Point)this.MemberwiseClone();

    // Then fill in the gaps.
    PointDescription currentDesc = new PointDescription();
    currentDesc.PetName = this.desc.PetName;
    newPoint.desc = currentDesc;
    return newPoint;
}
```

If you rerun the application once again and view the output (shown next), you see that the Point returned from Clone() does copy its internal reference type member variables (note the pet name is now unique for both p3 and p4).

```
***** Fun with Object Cloning *****

Cloned p3 and stored new Point in p4
Before modification:
p3: X = 100; Y = 100; Name = Jane;
ID = 51f64f25-4b0e-47ac-ba35-37d263496406
```

```
p4: X = 100; Y = 100; Name = Jane;
ID = 0d3776b3-b159-490d-b022-7f3f60788e8a
```

Changed `p4.desc.petName` and `p4.X`

After modification:

```
p3: X = 100; Y = 100; Name = Jane;
ID = 51f64f25-4b0e-47ac-ba35-37d263496406
```

```
p4: X = 9; Y = 100; Name = My new Point;
ID = 0d3776b3-b159-490d-b022-7f3f60788e8a
```

To summarize the cloning process, if you have a class or structure that contains nothing but value types, implement your `Clone()` method using `MemberwiseClone()`. However, if you have a custom type that maintains other reference types, you might want to create a new object that takes into account each reference type member variable in order to get a “deep copy.”

■ **Source Code** The `CloneablePoint` project is located in the Chapter 8 subdirectory.

The IComparable Interface

The `System.IComparable` interface specifies a behavior that allows an object to be sorted based on some specified key. Here is the formal definition:

```
// This interface allows an object to specify its
// relationship between other like objects.
public interface IComparable
{
    int CompareTo(object o);
}
```

■ **Note** The generic version of this interface (`IComparable<T>`) provides a more type-safe manner to handle comparisons between objects. You’ll examine generics in Chapter 9.

Let’s assume you have a new Console Application project named `ComparableCar` that updates the `Car` class from Chapter 7 as so (notice that you have basically just added a new property to represent a unique ID for each car and a modified constructor):

```
public class Car
{
    ...
    public int CarID {get; set;}
    public Car(string name, int currSp, int id)
    {
        CurrentSpeed = currSp;
    }
}
```



```

        PetName = name;
        CarID = id;
    }
    ...
}

```

Now assume you have an array of Car objects as follows:

```

static void Main(string[] args)
{
    Console.WriteLine("***** Fun with Object Sorting *****\n");

    // Make an array of Car objects.
    Car[] myAutos = new Car[5];
    myAutos[0] = new Car("Rusty", 80, 1);
    myAutos[1] = new Car("Mary", 40, 234);
    myAutos[2] = new Car("Viper", 40, 34);
    myAutos[3] = new Car("Mel", 40, 4);
    myAutos[4] = new Car("Chucky", 40, 5);

    Console.ReadLine();
}

```

The `System.Array` class defines a static method named `Sort()`. When you invoke this method on an array of intrinsic types (`int`, `short`, `string`, etc.), you are able to sort the items in the array in numeric/alphabetic order, as these intrinsic data types implement `IComparable`. However, what if you were to send an array of `Car` types into the `Sort()` method as follows?

```

// Sort my cars? Not yet!
Array.Sort(myAutos);

```

If you run this test, you would get a runtime exception, as the `Car` class does not support the necessary interface. When you build custom types, you can implement `IComparable` to allow arrays of your types to be sorted. When you flesh out the details of `CompareTo()`, it will be up to you to decide what the baseline of the ordering operation will be. For the `Car` type, the internal `CarID` seems to be the logical candidate.

```

// The iteration of the Car can be ordered
// based on the CarID.
public class Car : IComparable
{
    ...
    // IComparable implementation.
    int IComparable.CompareTo(object obj)
    {
        Car temp = obj as Car;
        if (temp != null)
        {
            if (this.CarID > temp.CarID)
                return 1;
            if (this.CarID < temp.CarID)
                return -1;
        }
    }
}

```

```

        else
            return 0;
    }
    else
        throw new ArgumentException("Parameter is not a Car!");
    }
}

```

As you can see, the logic behind `CompareTo()` is to test the incoming object against the current instance based on a specific point of data. The return value of `CompareTo()` is used to discover whether this type is less than, greater than, or equal to the object it is being compared with (see Table 8-1).

Table 8-1. *CompareTo() Return Values*

| CompareTo() Return Value | Description |
|---------------------------------|--|
| Any number less than zero | This instance comes before the specified object in the sort order. |
| Zero | This instance is equal to the specified object. |
| Any number greater than zero | This instance comes after the specified object in the sort order. |

You can streamline the previous implementation of `CompareTo()` given that the C# `int` data type (which is just a shorthand notation for the CLR `System.Int32`) implements `IComparable`. You could implement the `Car`'s `CompareTo()` as follows:

```

int IComparable.CompareTo(object obj)
{
    Car temp = obj as Car;
    if (temp != null)
        return this.CarID.CompareTo(temp.CarID);
    else
        throw new ArgumentException("Parameter is not a Car!");
}

```

In either case, so that your `Car` type understands how to compare itself to like objects, you can write the following user code:

```

// Exercise the IComparable interface.
static void Main(string[] args)
{
    // Make an array of Car objects.
    ...
    // Display current array.
    Console.WriteLine("Here is the unordered set of cars:");
    foreach(Car c in myAutos)
        Console.WriteLine("{0} {1}", c.CarID, c.PetName);

    // Now, sort them using IComparable!
    Array.Sort(myAutos);
    Console.WriteLine();
}

```

```
// Display sorted array.
Console.WriteLine("Here is the ordered set of cars:");
foreach(Car c in myAutos)
    Console.WriteLine("{0} {1}", c.CarID, c.PetName);
Console.ReadLine();
}
```

Here is the output from the previous `Main()` method:

```
***** Fun with Object Sorting *****
```

Here is the unordered set of cars:

```
1 Rusty
234 Mary
34 Viper
4 Mel
5 Chucky
```

Here is the ordered set of cars:

```
1 Rusty
4 Mel
5 Chucky
34 Viper
234 Mary
```

Specifying Multiple Sort Orders with `IComparer`

In this version of the `Car` type, you used the car's ID as the base for the sort order. Another design might have used the pet name of the car as the basis for the sorting algorithm (to list cars alphabetically). Now, what if you wanted to build a `Car` that could be sorted by ID *as well as* by pet name? If this is the type of behavior you are interested in, you need to make friends with another standard interface named `IComparer`, defined within the `System.Collections` namespace as follows:

```
// A general way to compare two objects.
interface IComparer
{
    int Compare(object o1, object o2);
}
```

■ **Note** The generic version of this interface (`IComparer<T>`) provides a more type-safe manner to handle comparisons between objects. You'll examine generics in Chapter 9.

Unlike the `IComparable` interface, `IComparer` is typically *not* implemented on the type you are trying to sort (i.e., the `Car`). Rather, you implement this interface on any number of helper classes, one for each sort order (pet name, car ID, etc.). Currently, the `Car` type already knows how to compare itself against other cars based on the internal car ID. Therefore, allowing the object user to sort an array of `Car` objects by pet name

will require an additional helper class that implements `IComparer`. Here's the code (be sure to import the `System.Collections` namespace in the code file):

```
// This helper class is used to sort an array of Cars by pet name.
public class PetNameComparer : IComparer
{
    // Test the pet name of each object.
    int IComparer.Compare(object o1, object o2)
    {

        Car t1 = o1 as Car;
        Car t2 = o2 as Car;
        if(t1 != null && t2 != null)
            return String.Compare(t1.PetName, t2.PetName);
        else
            throw new ArgumentException("Parameter is not a Car!");
    }
}
```

The object user code is able to use this helper class. `System.Array` has a number of overloaded `Sort()` methods, one that just happens to take an object implementing `IComparer`.

```
static void Main(string[] args)
{
    ...
    // Now sort by pet name.
    Array.Sort(myAutos, new PetNameComparer());

    // Dump sorted array.
    Console.WriteLine("Ordering by pet name:");
    foreach(Car c in myAutos)
        Console.WriteLine("{0} {1}", c.CarID, c.PetName);
    ...
}
```

Custom Properties and Custom Sort Types

It is worth pointing out that you can use a custom static property to help the object user along when sorting your `Car` types by a specific data point. Assume the `Car` class has added a static read-only property named `SortByPetName` that returns an instance of an object implementing the `IComparer` interface (`PetNameComparer`, in this case; be sure to import `System.Collections`).

```
// We now support a custom property to return
// the correct IComparer interface.
public class Car : IComparable
{
    ...
    // Property to return the PetNameComparer.
    public static IComparer SortByPetName
    { get { return (IComparer)new PetNameComparer(); } }
}
```

The object user code can now sort by pet name using a strongly associated property, rather than just “having to know” to use the stand-alone `PetNameComparer` class type.

```
// Sorting by pet name made a bit cleaner.  
Array.Sort(myAutos, Car.SortByPetName);
```

■ **Source Code** The `ComparableCar` project is located in the [Chapter 8](#) subdirectory.

Ideally, at this point you not only understand how to define and implement your own interfaces but also understand their usefulness. To be sure, interfaces are found within every major .NET namespace, and you will continue working with various standard interfaces in the remainder of this book.

Summary

An interface can be defined as a named collection of *abstract members*. Because an interface does not provide any implementation details, it is common to regard an interface as a behavior that may be supported by a given type. When two or more classes implement the same interface, you can treat each type the same way (interface-based polymorphism) even if the types are defined within unique class hierarchies.

C# provides the `interface` keyword to allow you to define a new interface. As you have seen, a type can support as many interfaces as necessary using a comma-delimited list. Furthermore, it is permissible to build interfaces that derive from multiple base interfaces.

In addition to building your custom interfaces, the .NET libraries define a number of standard (i.e., framework-supplied) interfaces. As you have seen, you are free to build custom types that implement these predefined interfaces to gain a number of desirable traits such as cloning, sorting, and enumerating.

PART IV



Advanced C# Programming

CHAPTER 9



Collections and Generics

Any application you create with the .NET platform will need to contend with the issue of maintaining and manipulating a set of data points in memory. These data points can come from any variety of locations including a relational database, a local text file, an XML document, a web service call, or perhaps via user-provided input.

When the .NET platform was first released, programmers frequently used the classes of the `System.Collections` namespace to store and interact with bits of data used within an application. In .NET 2.0, the C# programming language was enhanced to support a feature termed *generics*; and with this change, a brand new namespace was introduced in the base class libraries: `System.Collections.Generic`.

This chapter will provide you with an overview of the various collection (generic and nongeneric) namespaces and types found within the .NET base class libraries. As you will see, generic containers are often favored over their nongeneric counterparts because they typically provide greater type safety and performance benefits. After you've learned how to create and manipulate the generic items found in the framework, the remainder of this chapter will examine how to build your own generic methods and generic types. As you do this, you will learn about the role of *constraints* (and the corresponding C# `where` keyword), which allow you to build extremely type-safe classes.

The Motivation for Collection Classes

The most primitive container you could use to hold application data is undoubtedly the array. As you saw in Chapter 4, C# arrays allow you to define a set of identically typed items (including an array of `System.Objects`, which essentially represents an array of any type of data) of a fixed upper limit. Also recall from Chapter 4 that all C# array variables gather a good deal of functionality from the `System.Array` class. By way of a quick review, consider the following `Main()` method, which creates an array of textual data and manipulates its contents in various ways:

```
static void Main(string[] args)
{
    // Make an array of string data.
    string[] strArray = {"First", "Second", "Third" };

    // Show number of items in array using Length property.
    Console.WriteLine("This array has {0} items.", strArray.Length);
    Console.WriteLine();

    // Display contents using enumerator.
    foreach (string s in strArray)
```

```

{
    Console.WriteLine("Array Entry: {0}", s);
}
Console.WriteLine();

// Reverse the array and print again.
Array.Reverse(strArray);
foreach (string s in strArray)
{
    Console.WriteLine("Array Entry: {0}", s);
}

Console.ReadLine();
}

```

While basic arrays can be useful to manage small amounts of fixed-size data, there are many other times where you require a more flexible data structure, such as a dynamically growing and shrinking container or a container that can hold objects that meet only a specific criteria (e.g., only objects deriving from a specific base class or only objects implementing a particular interface). When you make use of a simple array, always remember they are “fixed size.” If you make an array of three items, you get only three items; therefore, the following code would result in a runtime exception (an `IndexOutOfRangeException`, to be exact):

```

static void Main(string[] args)
{
    // Make an array of string data.
    string[] strArray = { "First", "Second", "Third" };

    // Try to add a new item at the end?? Runtime error!
    strArray[3] = "new item?";
    ...
}

```

■ **Note** It is actually possible to change the size of an array using the generic `Resize(<T>)` method. However, this will result in a copy of the data into a new array object and could be inefficient.

To help overcome the limitations of a simple array, the .NET base class libraries ship with a number of namespaces containing *collection classes*. Unlike a simple C# array, collection classes are built to dynamically resize themselves on the fly as you insert or remove items. Moreover, many of the collection classes offer increased type safety and are highly optimized to process the contained data in a memory-efficient manner. As you read over this chapter, you will quickly notice that a collection class can belong to one of two broad categories.

- Nongeneric collections (primarily found in the `System.Collections` namespace)
- Generic collections (primarily found in the `System.Collections.Generic` namespace)

Nongeneric collections are typically designed to operate on `System.Object` types and are, therefore, loosely typed containers (however, some nongeneric collections do operate only on a specific type of data, such as `string` objects). In contrast, generic collections are much more type safe, given that you must specify the “type of type” they contain upon creation. As you will see, the telltale sign of any generic item is the “type parameter” marked with angled brackets (for example, `List<T>`). You will examine the details of generics (including the many benefits they provide) a bit later in this chapter. For now, let’s examine some of the key nongeneric collection types in the `System.Collections` and `System.Collections.Specialized` namespaces.

The System.Collections Namespace

When the .NET platform was first released, programmers frequently used the nongeneric collection classes found within the `System.Collections` namespace, which contains a set of classes used to manage and organize large amounts of in-memory data. Table 9-1 documents some of the more commonly used collection classes of this namespace and the core interfaces they implement.

Table 9-1. *Useful Types of System.Collections*

| System.Collections Class | Meaning in Life | Key Implemented Interfaces |
|---------------------------------|--|---|
| ArrayList | Represents a dynamically sized collection of objects listed in sequential order | IList, ICollection, IEnumerable, and ICloneable |
| BitArray | Manages a compact array of bit values, which are represented as Booleans, where true indicates that the bit is on (1) and false indicates the bit is off (0) | ICollection, IEnumerable, and ICloneable |
| Hashtable | Represents a collection of key-value pairs that are organized based on the hash code of the key | IDictionary, ICollection, IEnumerable, and ICloneable |
| Queue | Represents a standard first-in, first-out (FIFO) collection of objects | ICollection, IEnumerable, and ICloneable |
| SortedList | Represents a collection of key-value pairs that are sorted by the keys and are accessible by key and by index | IDictionary, ICollection, IEnumerable, and ICloneable |
| Stack | A last-in, first-out (LIFO) stack providing push and pop (and peek) functionality | ICollection, IEnumerable, and ICloneable |

The interfaces implemented by these collection classes provide huge insights into their overall functionality. Table 9-2 documents the overall nature of these key interfaces, some of which you worked with firsthand in Chapter 8.

Table 9-2. *Key Interfaces Supported by Classes of System.Collections*

| System.Collections Interface | Meaning in Life |
|-------------------------------------|--|
| ICollection | Defines general characteristics (e.g., size, enumeration, and thread safety) for all nongeneric collection types |
| ICloneable | Allows the implementing object to return a copy of itself to the caller |
| IDictionary | Allows a nongeneric collection object to represent its contents using key-value pairs |
| IEnumerable | Returns an object implementing the IEnumerator interface (see next table entry) |
| IEnumerator | Enables foreach style iteration of collection items |
| IList | Provides behavior to add, remove, and index items in a sequential list of objects |

An Illustrative Example: Working with the ArrayList

Based on your experience, you might have some firsthand experience using (or implementing) some of these classic data structures such as stacks, queues, and lists. If this is not the case, I'll provide some further details on their differences when you examine their generic counterparts a bit later in this chapter. Until then, here is a `Main()` method making use of an `ArrayList` object. Notice that you can add (or remove) items on the fly and the container automatically resizes itself accordingly.

```
// You must import System.Collections to access the ArrayList.
static void Main(string[] args)
{
    ArrayList strArray = new ArrayList();
    strArray.AddRange(new string[] { "First", "Second", "Third" });

    // Show number of items in ArrayList.
    Console.WriteLine("This collection has {0} items.", strArray.Count);
    Console.WriteLine();

    // Add a new item and display current count.
    strArray.Add("Fourth!");
    Console.WriteLine("This collection has {0} items.", strArray.Count);

    // Display contents.
    foreach (string s in strArray)
    {
        Console.WriteLine("Entry: {0}", s);
    }
    Console.WriteLine();
}
```

As you would guess, the `ArrayList` class has many useful members beyond the `Count` property and `AddRange()` and `Add()` methods, so be sure you consult the .NET Framework documentation for full details. On a related note, the other classes of `System.Collections` (`Stack`, `Queue`, and so on) are also fully documented in the .NET help system.

However, it is important to point out that a majority of your .NET projects will most likely *not* make use of the collection classes in the `System.Collections` namespace! To be sure, these days it is far more common to make use of the generic counterpart classes found in the `System.Collections.Generic` namespace. Given this point, I won't comment on (or provide code examples for) the remaining nongeneric classes found in `System.Collections`.

A Survey of System.Collections.Specialized Namespace

`System.Collections` is not the only .NET namespace that contains nongeneric collection classes. The `System.Collections.Specialized` namespace defines a number of (pardon the redundancy) specialized collection types. Table 9-3 documents some of the more useful types in this particular collection-centric namespace, all of which are nongeneric.

Table 9-3. *Useful Classes of System.Collections.Specialized*

| System.Collections.Specialized Type | Meaning in Life |
|--|--|
| HybridDictionary | This class implements IDictionary by using a ListDictionary while the collection is small and then switching to a Hashtable when the collection gets large. |
| ListDictionary | This class is useful when you need to manage a small number of items (ten or so) that can change over time. This class makes use of a singly linked list to maintain its data. |
| StringCollection | This class provides an optimal way to manage large collections of string data. |
| BitVector32 | This class provides a simple structure that stores Boolean values and small integers in 32 bits of memory. |

Beyond these concrete class types, this namespace also contains many additional interfaces and abstract base classes that you can use as a starting point for creating custom collection classes. While these “specialized” types might be just what your projects require in some situations, I won’t comment on their usage here. Again, in many cases, you will likely find that the `System.Collections.Generic` namespace provides classes with similar functionality and additional benefits.

■ **Note** There are two additional collection-centric namespaces (`System.Collections.ObjectModel` and `System.Collections.Concurrent`) in the .NET base class libraries. You will examine the former namespace later in this chapter, after you are comfortable with the topic of generics. `System.Collections.Concurrent` provides collection classes well-suited to a multithreaded environment (see Chapter 19 for information on multithreading).

The Problems of Nongeneric Collections

While it is true that many successful .NET applications have been built over the years using these nongeneric collection classes (and interfaces), history has shown that use of these types can result in a number of issues.

The first issue is that using the `System.Collections` and `System.Collections.Specialized` classes can result in some poorly performing code, especially when you are manipulating numerical data (e.g., value types). As you’ll see momentarily, the CLR must perform a number of memory transfer operations when you store structures in any nongeneric collection class prototyped to operate on `System.Objects`, which can hurt runtime execution speed.

The second issue is that most of the nongeneric collection classes are not type safe because (again) they were developed to operate on `System.Objects`, and they could therefore contain anything at all. If a .NET developer needed to create a highly type-safe collection (e.g., a container that can hold objects implementing only a certain interface), the only real choice was to create a new collection class by hand. Doing so was not too labor intensive, but it was a tad on the tedious side.

Before you look at how to use generics in your programs, you'll find it helpful to examine the issues of nongeneric collection classes a bit closer; this will help you better understand the problems generics intend to solve in the first place. If you want to follow along, create a new Console Application project named `IssuesWithNonGenericCollections`. Next, make sure you import the `System.Collections` namespace to the top of your C# code file.

```
using System.Collections;
```

The Issue of Performance

As you might recall from Chapter 4, the .NET platform supports two broad categories of data: value types and reference types. Given that .NET defines two major categories of types, you might occasionally need to represent a variable of one category as a variable of the other category. To do so, C# provides a simple mechanism, termed *boxing*, to store the data in a value type within a reference variable. Assume that you have created a local variable of type `int` in a method called `SimpleBoxUnboxOperation()`. If, during the course of your application, you were to represent this value type as a reference type, you would *box* the value, as follows:

```
static void SimpleBoxUnboxOperation()
{
    // Make a ValueType (int) variable.
    int myInt = 25;

    // Box the int into an object reference.
    object boxedInt = myInt;
}
```

Boxing can be formally defined as the process of explicitly assigning a value type to a `System.Object` variable. When you box a value, the CLR allocates a new object on the heap and copies the value type's value (25, in this case) into that instance. What is returned to you is a reference to the newly allocated heap-based object.

The opposite operation is also permitted through *unboxing*. Unboxing is the process of converting the value held in the object reference back into a corresponding value type on the stack. Syntactically speaking, an unboxing operation looks like a normal casting operation. However, the semantics are quite different. The CLR begins by verifying that the receiving data type is equivalent to the boxed type, and if so, it copies the value back into a local stack-based variable. For example, the following unboxing operations work successfully, given that the underlying type of the `boxedInt` is indeed an `int`:

```
static void SimpleBoxUnboxOperation()
{
    // Make a ValueType (int) variable.
    int myInt = 25;

    // Box the int into an object reference.
    object boxedInt = myInt;

    // Unbox the reference back into a corresponding int.
    int unboxedInt = (int)boxedInt;
}
```

When the C# compiler encounters boxing/unboxing syntax, it emits CIL code that contains the `box/unbox` op codes. If you were to examine your compiled assembly using `ildasm.exe`, you would find the following:

```
.method private hidebysig static void SimpleBoxUnboxOperation() cil managed
{
    // Code size 19 (0x13)
    .maxstack 1
    .locals init ([0] int32 myInt, [1] object boxedInt, [2] int32 unboxedInt)
    IL_0000: nop
    IL_0001: ldc.i4.s 25
    IL_0003: stloc.0
    IL_0004: ldloc.0
    IL_0005: box [mscorlib]System.Int32
    IL_000a: stloc.1
    IL_000b: ldloc.1
    IL_000c: unbox.any [mscorlib]System.Int32
    IL_0011: stloc.2
    IL_0012: ret
} // end of method Program::SimpleBoxUnboxOperation
```

Remember that unlike when performing a typical cast, you *must* unbox into an appropriate data type. If you attempt to unbox a piece of data into the incorrect data type, an `InvalidCastException` exception will be thrown. To be perfectly safe, you should wrap each unboxing operation in `try/catch` logic; however, this would be quite labor intensive to do for every unboxing operation. Consider the following code update, which will throw an error because you're attempting to unbox the boxed `int` into a `long`:

```
static void SimpleBoxUnboxOperation()
{
    // Make a ValueType (int) variable.
    int myInt = 25;

    // Box the int into an object reference.
    object boxedInt = myInt;

    // Unbox in the wrong data type to trigger
    // runtime exception.
    try
    {
        long unboxedInt = (long)boxedInt;
    }
    catch (InvalidCastException ex)
    {
        Console.WriteLine(ex.Message);
    }
}
```

At first glance, boxing/unboxing might seem like a rather uneventful language feature that is more academic than practical. After all, you will seldom need to store a local value type in a local object variable, as shown here. However, it turns out that the boxing/unboxing process is quite helpful because it allows you to assume everything can be treated as a `System.Object`, while the CLR takes care of the memory-related details on your behalf.

Let's look at a practical use of these techniques. Assume you have created a nongeneric `System.Collections.ArrayList` to hold onto a batch of numeric (stack-allocated) data. If you were to examine the members of `ArrayList`, you would find they are prototyped to operate on `System.Object` data. Now consider the `Add()`, `Insert()`, and `Remove()` methods, as well as the class indexer.

```
public class ArrayList : object,
    IList, ICollection, IEnumerable, ICloneable
{
    ...
    public virtual int Add(object value);
    public virtual void Insert(int index, object value);
    public virtual void Remove(object obj);
    public virtual object this[int index] {get; set; }
}
```

`ArrayList` has been built to operate on objects, which represent data allocated on the heap, so it might seem strange that the following code compiles and executes without throwing an error:

```
static void WorkWithArrayList()
{
    // Value types are automatically boxed when
    // passed to a method requesting an object.
    ArrayList myInts = new ArrayList();
    myInts.Add(10);
    myInts.Add(20);
    myInts.Add(35);
}
```

Although you pass in numerical data directly into methods requiring an object, the runtime automatically boxes the stack-based data on your behalf. Later, if you want to retrieve an item from the `ArrayList` using the type indexer, you must unbox the heap-allocated object into a stack-allocated integer using a casting operation. Remember that the indexer of the `ArrayList` is returning `System.Objects`, not `System.Int32s`.

```
static void WorkWithArrayList()
{
    // Value types are automatically boxed when
    // passed to a member requesting an object.
    ArrayList myInts = new ArrayList();
    myInts.Add(10);
    myInts.Add(20);
    myInts.Add(35);

    // Unboxing occurs when an object is converted back to
    // stack-based data.
    int i = (int)myInts[0];

    // Now it is reboxed, as WriteLine() requires object types!
    Console.WriteLine("Value of your int: {0}", i);
}
```

Again, note that the stack-allocated `System.Int32` is boxed prior to the call to `ArrayList.Add()`, so it can be passed in the required `System.Object`. Also note that the `System.Object` is unboxed back into a `System.Int32` once it is retrieved from the `ArrayList` via the casting operation, only to be boxed *again* when it is passed to the `Console.WriteLine()` method, as this method is operating on `System.Object` variables.

Boxing and unboxing are convenient from a programmer's viewpoint, but this simplified approach to stack/heap memory transfer comes with the baggage of performance issues (in both speed of execution and code size) and a lack of type safety. To understand the performance issues, ponder the steps that must occur to box and unbox a simple integer.

1. A new object must be allocated on the managed heap.
2. The value of the stack-based data must be transferred into that memory location.
3. When unboxed, the value stored on the heap-based object must be transferred back to the stack.
4. The now unused object on the heap will (eventually) be garbage collected.

Although this particular `WorkWithArrayList()` method won't cause a major bottleneck in terms of performance, you could certainly feel the impact if an `ArrayList` contained thousands of integers that your program manipulates on a somewhat regular basis. In an ideal world, you could manipulate stack-based data in a container without any performance issues. Ideally, it would be nice if you did not have to have to bother plucking data from this container using `try/catch` scopes (this is exactly what generics let you achieve).

The Issue of Type Safety

I touched on the issue of type safety when covering unboxing operations. Recall that you must unbox your data into the same data type it was declared as before boxing. However, there is another aspect of type safety you must keep in mind in a generic-free world: the fact that a majority of the classes of `System.Collections` can typically hold anything whatsoever because their members are prototyped to operate on `System.Objects`. For example, this method builds an `ArrayList` of random bits of unrelated data:

```
static void ArrayListOfRandomObjects()
{
    // The ArrayList can hold anything at all.
    ArrayList allMyObjects = new ArrayList();
    allMyObjects.Add(true);
    allMyObjects.Add(new OperatingSystem(PlatformID.MacOSX, new Version(10, 0)));
    allMyObjects.Add(66);
    allMyObjects.Add(3.14);
}
```

In some cases, you will require an extremely flexible container that can hold literally anything (as shown here). However, most of the time you desire a *type-safe* container that can operate only on a particular type of data point. For example, you might need a container that can hold only database connections, bitmaps, or `IPointy-compatible` objects.

Prior to generics, the only way you could address this issue of type safety was to create a custom (strongly typed) collection class manually. Assume you want to create a custom collection that can contain only objects of type `Person`.

```
public class Person
{
    public int Age {get; set;}
    public string FirstName {get; set;}
    public string LastName {get; set;}

    public Person(){}
    public Person(string firstName, string lastName, int age)
    {
        Age = age;
        FirstName = firstName;
        LastName = lastName;
    }

    public override string ToString()
    {
        return string.Format("Name: {0} {1}, Age: {2}",
            FirstName, LastName, Age);
    }
}
```

To build a collection that can hold only `Person` objects, you could define a `System.Collections.ArrayList` member variable within a class named `PersonCollection` and configure all members to operate on strongly typed `Person` objects, rather than on `System.Object` types. Here is a simple example (a production-level custom collection could support many additional members and might extend an abstract base class from the `System.Collections` or `System.Collections.Specialized` namespace):

```
public class PersonCollection : IEnumerable
{
    private ArrayList arPeople = new ArrayList();

    // Cast for caller.
    public Person GetPerson(int pos)
    { return (Person)arPeople[pos]; }

    // Insert only Person objects.
    public void AddPerson(Person p)
    { arPeople.Add(p); }

    public void ClearPeople()
    { arPeople.Clear(); }

    public int Count
    { get { return arPeople.Count; } }

    // Foreach enumeration support.
    IEnumerator IEnumerable.GetEnumerator()
    { return arPeople.GetEnumerator(); }
}
```

Notice that the `PersonCollection` class implements the `IEnumerable` interface, which allows a `foreach`-like iteration over each contained item. Also notice that your `GetPerson()` and `AddPerson()` methods have been prototyped to operate only on `Person` objects, not bitmaps, strings, database connections, or other items. With these types defined, you are now assured of type safety, given that the C# compiler will be able to determine any attempt to insert an incompatible data type.

```
static void UsePersonCollection()
{
    Console.WriteLine("***** Custom Person Collection *****\n");
    PersonCollection myPeople = new PersonCollection();
    myPeople.AddPerson(new Person("Homer", "Simpson", 40));
    myPeople.AddPerson(new Person("Marge", "Simpson", 38));
    myPeople.AddPerson(new Person("Lisa", "Simpson", 9));
    myPeople.AddPerson(new Person("Bart", "Simpson", 7));
    myPeople.AddPerson(new Person("Maggie", "Simpson", 2));

    // This would be a compile-time error!
    // myPeople.AddPerson(new Car());

    foreach (Person p in myPeople)
        Console.WriteLine(p);
}
```

While custom collections do ensure type safety, this approach leaves you in a position where you must create an (almost identical) custom collection for each unique data type you want to contain. Thus, if you need a custom collection that can operate only on classes deriving from the `Car` base class, you need to build a highly similar collection class.

```
public class CarCollection : IEnumerable
{
    private ArrayList arCars = new ArrayList();

    // Cast for caller.
    public Car GetCar(int pos)
    { return (Car) arCars[pos]; }

    // Insert only Car objects.
    public void AddCar(Car c)
    { arCars.Add(c); }

    public void ClearCars()
    { arCars.Clear(); }

    public int Count
    { get { return arCars.Count; } }

    // Foreach enumeration support.
    IEnumerator IEnumerable.GetEnumerator()
    { return arCars.GetEnumerator(); }
}
```

However, a custom collection class does nothing to solve the issue of boxing/unboxing penalties. Even if you were to create a custom collection named `IntCollection` that you designed to operate only on `System.Int32` items, you would have to allocate some type of object to hold the data (e.g., `System.Array` and `ArrayList`).

```
public class IntCollection : IEnumerable
{
    private ArrayList arInts = new ArrayList();

    // Get an int (performs unboxing!).
    public int GetInt(int pos)
    { return (int)arInts[pos]; }

    // Insert an int (performs boxing)!
    public void AddInt(int i)
    { arInts.Add(i); }

    public void ClearInts()
    { arInts.Clear(); }

    public int Count
    { get { return arInts.Count; } }

    IEnumerator IEnumerable.GetEnumerator()
    { return arInts.GetEnumerator(); }
}
```

Regardless of which type you might choose to hold the integers, you cannot escape the boxing dilemma using nongeneric containers.

A First Look at Generic Collections

When you use generic collection classes, you rectify all the previous issues, including boxing/unboxing penalties and a lack of type safety. Also, the need to build a custom (generic) collection class becomes quite rare. Rather than having to build unique classes that can contain people, cars, and integers, you can use a generic collection class and specify the type of type.

Consider the following method, which uses the generic `List<T>` class (in the `System.Collections.Generic` namespace) to contain various types of data in a strongly typed manner (don't fret the details of generic syntax at this time):

```
static void UseGenericList()
{
    Console.WriteLine("***** Fun with Generics *****\n");

    // This List<> can hold only Person objects.
    List<Person> morePeople = new List<Person>();
    morePeople.Add(new Person ("Frank", "Black", 50));
    Console.WriteLine(morePeople[0]);
}
```

```

// This List<T> can hold only integers.
List<int> moreInts = new List<int>();
moreInts.Add(10);
moreInts.Add(2);
int sum = moreInts[0] + moreInts[1];

// Compile-time error! Can't add Person object
// to a list of ints!
// moreInts.Add(new Person());
}

```

The first `List<T>` object can contain only `Person` objects. Therefore, you do not need to perform a cast when plucking the items from the container, which makes this approach more type safe. The second `List<T>` can contain only integers, all of which are allocated on the stack; in other words, there is no hidden boxing or unboxing as you found with the nongeneric `ArrayList`. Here is a short list of the benefits generic containers provide over their nongeneric counterparts:

- Generics provide better performance because they do not result in boxing or unboxing penalties when storing value types.
- Generics are type safe because they can contain only the type of type you specify.
- Generics greatly reduce the need to build custom collection types because you specify the “type of type” when creating the generic container.

■ **Source Code** You can find the `IssuesWithNonGenericCollections` project in the `Chapter 9` subdirectory.

The Role of Generic Type Parameters

You can find generic classes, interfaces, structures, and delegates throughout the .NET base class libraries, and these might be part of any .NET namespace. Also be aware that generics have far more uses than simply defining a collection class. To be sure, you will see many different generics used in the remainder of this book for various reasons.

■ **Note** Only classes, structures, interfaces, and delegates can be written generically; enum types cannot.

When you see a generic item listed in the .NET Framework documentation or the Visual Studio object browser, you will notice a pair of angled brackets with a letter or other token sandwiched within. Figure 9-1 shows the Visual Studio object browser displaying a number of generic items located within the `System.Collections.Generic` namespace, including the highlighted `List<T>` class.

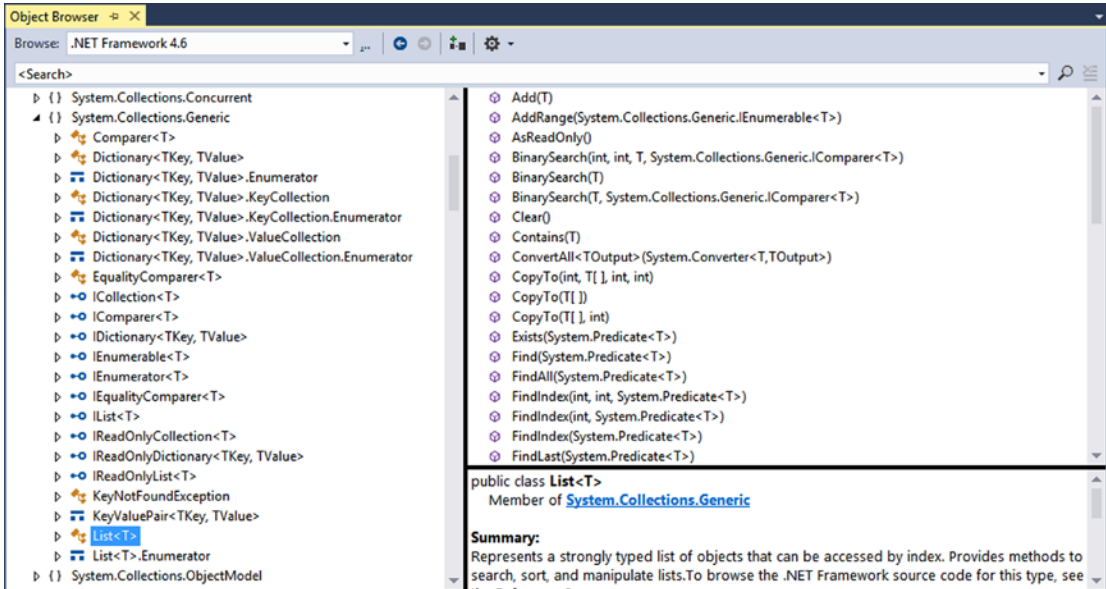

Figure 9-1. Generic items supporting type parameters

Formally speaking, you call these tokens *type parameters*; however, in more user-friendly terms, you can simply call them *placeholders*. You can read the symbol <T> as “of T.” Thus, you can read IEnumerable<T> “as IEnumerable of T” or, to say it another way, “IEnumerable of type T.”

■ Note The name of a type parameter (placeholder) is irrelevant, and it is up to the developer who created the generic item. However, typically *T* is used to represent types, *TKey* or *K* is used for keys, and *TValue* or *V* is used for values.

When you create a generic object, implement a generic interface, or invoke a generic member, it is up to you to supply a value to the type parameter. You’ll see many examples in this chapter and throughout the remainder of the text. However, to set the stage, let’s see the basics of interacting with generic types and members.

Specifying Type Parameters for Generic Classes/Structures

When you create an instance of a generic class or structure, you specify the type parameter when you declare the variable and when you invoke the constructor. As you saw in the preceding code example, `UseGenericList()` defined two `List<T>` objects.

```
// This List<> can hold only Person objects.
List<Person> morePeople = new List<Person>();
```

You can read the preceding snippet as “a List<> of T, where T is of type Person.” Or, more simply, you can read it as “a list of person objects.” After you specify the type parameter of a generic item, it cannot be changed (remember, generics are all about type safety). When you specify a type parameter for a generic class or structure, all occurrences of the placeholder(s) are now replaced with your supplied value.

If you were to view the full declaration of the generic List<T> class using the Visual Studio object browser, you would see that the placeholder T is used throughout the definition of the List<T> type. Here is a partial listing (note the items in **bold**):

```
// A partial listing of the List<T> class.
namespace System.Collections.Generic
{
    public class List<T> :
        IList<T>, ICollection<T>, IEnumerable<T>, IReadOnlyList<T>
        IList, ICollection, IEnumerable
    {
        ...
        public void Add(T item);
        public ReadOnlyCollection<T> AsReadOnly();
        public int BinarySearch(T item);
        public bool Contains(T item);
        public void CopyTo(T array);
        public int FindIndex(System.Predicate<T> match);
        public T FindLast(System.Predicate<T> match);
        public bool Remove(T item);
        public int RemoveAll(System.Predicate<T> match);
        public T[] ToArray();
        public bool TrueForAll(System.Predicate<T> match);
        public T this[int index] { get; set; }
    }
}
```

When you create a List<T> specifying Person objects, it is as if the List<T> type were defined as follows:

```
namespace System.Collections.Generic
{
    public class List<Person> :
        IList<Person>, ICollection<Person>, IEnumerable<Person>, IReadOnlyList<Person>
        IList, ICollection, IEnumerable
    {
        ...
        public void Add(Person item);
        public ReadOnlyCollection<Person> AsReadOnly();
        public int BinarySearch(Person item);
        public bool Contains(Person item);
        public void CopyTo(Person array);
        public int FindIndex(System.Predicate<Person> match);
        public Person FindLast(System.Predicate<Person> match);
        public bool Remove(Person item);
        public int RemoveAll(System.Predicate<Person> match);
        public Person[] ToArray();
    }
}
```

```

    public bool TrueForAll(System.Predicate<Person> match);
    public Person this[int index] { get; set; }
}
}

```

Of course, when you create a generic `List<T>` variable, the compiler does not literally create a new implementation of the `List<T>` class. Rather, it will address only the members of the generic type you actually invoke.

Specifying Type Parameters for Generic Members

It is fine for a nongeneric class or structure to support a handful of generic members (e.g., methods and properties). In these cases, you would also need to specify the placeholder value at the time you invoke the method. For example, `System.Array` supports a several generic methods. Specifically, the nongeneric static `Sort()` method now has a generic counterpart named `Sort<T>()`. Consider the following code snippet, where `T` is of type `int`:

```

int[] myInts = { 10, 4, 2, 33, 93 };

// Specify the placeholder to the generic
// Sort<>() method.
Array.Sort<int>(myInts);

foreach (int i in myInts)
{
    Console.WriteLine(i);
}

```

Specifying Type Parameters for Generic Interfaces

It is common to implement generic interfaces when you build classes or structures that need to support various framework behaviors (e.g., cloning, sorting, and enumeration). In Chapter 8, you learned about a number of nongeneric interfaces, such as `IComparable`, `IEnumerable`, `IEnumerator`, and `IComparer`. Recall that the nongeneric `IComparable` interface was defined like this:

```

public interface IComparable
{
    int CompareTo(object obj);
}

```

In Chapter 8, you also implemented this interface on your `Car` class to enable sorting in a standard array. However, the code required several runtime checks and casting operations because the parameter was a general `System.Object`.

```

public class Car : IComparable
{
    ...
    // IComparable implementation.
    int IComparable.CompareTo(object obj)

```

```

{
    Car temp = obj as Car;
    if (temp != null)
    {
        if (this.CarID > temp.CarID)
            return 1;
        if (this.CarID < temp.CarID)
            return -1;
        else
            return 0;
    }
    else
        throw new ArgumentException("Parameter is not a Car!");
}
}

```

Now assume you use the generic counterpart of this interface.

```

public interface IComparable<T>
{
    int CompareTo(T obj);
}

```

In this case, your implementation code will be cleaned up considerably.

```

public class Car : IComparable<Car>
{
    ...
    // IComparable<T> implementation.
    int IComparable<Car>.CompareTo(Car obj)
    {
        if (this.CarID > obj.CarID)
            return 1;
        if (this.CarID < obj.CarID)
            return -1;
        else
            return 0;
    }
}

```

Here, you do not need to check whether the incoming parameter is a *Car* because it can *only* be a *Car*! If someone were to pass in an incompatible data type, you would get a compile-time error. Now that you have a better handle on how to interact with generic items, as well as the role of type parameters (a.k.a. placeholders), you're ready to examine the classes and interfaces of the `System.Collections.Generic` namespace.

The System.Collections.Generic Namespace

When you are building a .NET application and need a way to manage in-memory data, the classes of `System.Collections.Generic` will most likely fit the bill. At the opening of this chapter, I briefly mentioned some of the core nongeneric interfaces implemented by the nongeneric collection classes. Not too surprisingly, the `System.Collections.Generic` namespace defines generic replacements for many of them.

In fact, you can find a number of the generic interfaces that extend their nongeneric counterparts. This might seem odd; however, by doing so, implementing classes will also support the legacy functionality found in their nongeneric siblings. For example, `IEnumerable<T>` extends `IEnumerable`. Table 9-4 documents the core generic interfaces you'll encounter when working with the generic collection classes.

Table 9-4. Key Interfaces Supported by Classes of *System.Collections.Generic*

| System.Collections.Generic Interface | Meaning in Life |
|--|---|
| <code>ICollection<T></code> | Defines general characteristics (e.g., size, enumeration, and thread safety) for all generic collection types |
| <code>IComparer<T></code> | Defines a way to compare to objects |
| <code>IDictionary<TKey, TValue></code> | Allows a generic collection object to represent its contents using key-value pairs |
| <code>IEnumerable<T></code> | Returns the <code>IEnumerator<T></code> interface for a given object |
| <code>IEnumerator<T></code> | Enables foreach-style iteration over a generic collection |
| <code>ICollection<T></code> | Provides behavior to add, remove, and index items in a sequential list of objects |
| <code>ISet<T></code> | Provides the base interface for the abstraction of sets |

The `System.Collections.Generic` namespace also defines several classes that implement many of these key interfaces. Table 9-5 describes some commonly used classes of this namespace, the interfaces they implement, and their basic functionality.

Table 9-5. Classes of *System.Collections.Generic*

| Generic Class | Supported Key Interfaces | Meaning in Life |
|---|---|---|
| <code>Dictionary<TKey, TValue></code> | <code>ICollection<T></code> , <code>IDictionary<TKey, TValue></code> , <code>IEnumerable<T></code> | This represents a generic collection of keys and values. |
| <code>LinkedList<T></code> | <code>ICollection<T></code> , <code>IEnumerable<T></code> | This represents a doubly linked list. |
| <code>List<T></code> | <code>ICollection<T></code> , <code>IEnumerable<T></code> , <code>ICollection<T></code> | This is a dynamically resizable sequential list of items. |
| <code>Queue<T></code> | <code>ICollection</code> (Not a typo! This is the nongeneric collection interface), <code>IEnumerable<T></code> | This is a generic implementation of a first-in, first-out (FIFO) list. |
| <code>SortedDictionary<TKey, TValue></code> | <code>ICollection<T></code> , <code>IDictionary<TKey, TValue></code> , <code>IEnumerable<T></code> | This is a generic implementation of a sorted set of key-value pairs. |
| <code>SortedSet<T></code> | <code>ICollection<T></code> , <code>IEnumerable<T></code> , <code>ISet<T></code> | This represents a collection of objects that is maintained in sorted order with no duplication. |
| <code>Stack<T></code> | <code>ICollection</code> (Not a typo! This is the nongeneric collection interface), <code>IEnumerable<T></code> | This is a generic implementation of a last-in, first-out (LIFO) list. |

The `System.Collections.Generic` namespace also defines many auxiliary classes and structures that work in conjunction with a specific container. For example, the `LinkedListNode<T>` type represents a node within a generic `LinkedList<T>`, the `KeyNotFoundException` exception is raised when attempting to grab an item from a container using a nonexistent key, and so forth.

It is also worth pointing out that `mscorlib.dll` and `System.dll` are not the only assemblies that add new types to the `System.Collections.Generic` namespace. For example, `System.Core.dll` adds the `HashSet<T>` class to the mix. Be sure to consult the .NET Framework documentation for full details of the `System.Collections.Generic` namespace.

In any case, your next task is to learn how to use some of these generic collection classes. Before you do, however, allow me to illustrate a C# language feature (first introduced in .NET 3.5) that simplifies the way you populate generic (and nongeneric) collection containers with data.

Understanding Collection Initialization Syntax

In Chapter 4, you learned about *object initialization syntax*, which allows you to set properties on a new variable at the time of construction. Closely related to this is *collection initialization syntax*. This C# language feature makes it possible to populate many containers (such as `ArrayList` or `List<T>`) with items by using syntax similar to what you use to populate a basic array.

■ **Note** You can apply collection initialization syntax only to classes that support an `Add()` method, which is formalized by the `ICollection<T>/ICollection` interfaces.

Consider the following examples:

```
// Init a standard array.
int[] myArrayOfInts = { 0, 1, 2, 3, 4, 5, 6, 7, 8, 9 };

// Init a generic List<> of ints.
List<int> myGenericList = new List<int> { 0, 1, 2, 3, 4, 5, 6, 7, 8, 9 };

// Init an ArrayList with numerical data.
ArrayList myList = new ArrayList { 0, 1, 2, 3, 4, 5, 6, 7, 8, 9 };
```

If your container is managing a collection of classes or a structure, you can blend object initialization syntax with collection initialization syntax to yield some functional code. You might recall the `Point` class from Chapter 5, which defined two properties named `X` and `Y`. If you wanted to build a generic `List<T>` of `Point` objects, you could write the following:

```
List<Point> myListOfPoints = new List<Point>
{
    new Point { X = 2, Y = 2 },
    new Point { X = 3, Y = 3 },
    new Point(PointColor.BloodRed){ X = 4, Y = 4 }
};

foreach (var pt in myListOfPoints)
{
    Console.WriteLine(pt);
}
```

Again, the benefit of this syntax is that you save yourself numerous keystrokes. While the nested curly brackets can become difficult to read if you don't mind your formatting, imagine the amount of code that would be required to fill the following `List<T>` of `Rectangle`s if you did not have collection initialization syntax (you might recall from Chapter 4 that you created a `Rectangle` class that contained two properties encapsulating `Point` objects).

```
List<Rectangle> myListOfRects = new List<Rectangle>
{
    new Rectangle {TopLeft = new Point { X = 10, Y = 10 },
                  BottomRight = new Point { X = 200, Y = 200}},
    new Rectangle {TopLeft = new Point { X = 2, Y = 2 },
                  BottomRight = new Point { X = 100, Y = 100}},
    new Rectangle {TopLeft = new Point { X = 5, Y = 5 },
                  BottomRight = new Point { X = 90, Y = 75}}
};

foreach (var r in myListOfRects)
{
    Console.WriteLine(r);
}
```

Working with the `List<T>` Class

Create a new Console Application project named `FunWithGenericCollections`. Note that your initial C# code file already imports the `System.Collections.Generic` namespace.

The first generic class you will examine is `List<T>`, which you've already seen once or twice in this chapter. The `List<T>` class is bound to be your most frequently used type in the `System.Collections.Generic` namespace because it allows you to resize the contents of the container dynamically. To illustrate the basics of this type, ponder the following method in your `Program` class, which leverages `List<T>` to manipulate the set of `Person` objects shown earlier in this chapter; you might recall that these `Person` objects defined three properties (`Age`, `FirstName`, and `LastName`) and a custom `ToString()` implementation:

```
static void UseGenericList()
{
    // Make a List of Person objects, filled with
    // collection/object init syntax.
    List<Person> people = new List<Person>()
    {
        new Person {FirstName= "Homer", LastName="Simpson", Age=47},
        new Person {FirstName= "Marge", LastName="Simpson", Age=45},
        new Person {FirstName= "Lisa", LastName="Simpson", Age=9},
        new Person {FirstName= "Bart", LastName="Simpson", Age=8}
    };

    // Print out # of items in List.
    Console.WriteLine("Items in list: {0}", people.Count);

    // Enumerate over list.
    foreach (Person p in people)
        Console.WriteLine(p);
}
```

```

// Insert a new person.
Console.WriteLine("\n->Inserting new person.");
people.Insert(2, new Person { FirstName = "Maggie", LastName = "Simpson", Age = 2 });
Console.WriteLine("Items in list: {0}", people.Count);

// Copy data into a new array.
Person[] arrayOfPeople = people.ToArray();
for (int i = 0; i < arrayOfPeople.Length; i++)
{
    Console.WriteLine("First Names: {0}", arrayOfPeople[i].FirstName);
}
}

```

Here, you use initialization syntax to populate your `List<T>` with objects, as a shorthand notation for calling `Add()` *multiple* times. After you print out the number of items in the collection (as well as enumerate over each item), you invoke `Insert()`. As you can see, `Insert()` allows you to plug a new item into the `List<T>` at a specified index.

Finally, notice the call to the `ToArray()` method, which returns an array of `Person` objects based on the contents of the original `List<T>`. From this array, you loop over the items again using the array's indexer syntax. If you call this method from within `Main()`, you get the following output:

```
***** Fun with Generic Collections *****
```

```

Items in list: 4
Name: Homer Simpson, Age: 47
Name: Marge Simpson, Age: 45
Name: Lisa Simpson, Age: 9
Name: Bart Simpson, Age: 8

```

```

->Inserting new person.
Items in list: 5
First Names: Homer
First Names: Marge
First Names: Maggie
First Names: Lisa
First Names: Bart

```

The `List<T>` class defines many additional members of interest, so be sure to consult the .NET Framework documentation for more information. Next, let's look at a few more generic collections, specifically `Stack<T>`, `Queue<T>`, and `SortedSet<T>`. This should get you in a great position to understand your basic choices regarding how to hold your custom application data.

Working with the Stack<T> Class

The Stack<T> class represents a collection that maintains items using a last-in, first-out manner. As you might expect, Stack<T> defines members named Push() and Pop() to place items onto or remove items from the stack. The following method creates a stack of Person objects:

```
static void UseGenericStack()
{
    Stack<Person> stackOfPeople = new Stack<Person>();
    stackOfPeople.Push(new Person
        { FirstName = "Homer", LastName = "Simpson", Age = 47 });
    stackOfPeople.Push(new Person
        { FirstName = "Marge", LastName = "Simpson", Age = 45 });
    stackOfPeople.Push(new Person
        { FirstName = "Lisa", LastName = "Simpson", Age = 9 });

    // Now look at the top item, pop it, and look again.
    Console.WriteLine("First person is: {0}", stackOfPeople.Peek());
    Console.WriteLine("Popped off {0}", stackOfPeople.Pop());
    Console.WriteLine("\nFirst person is: {0}", stackOfPeople.Peek());
    Console.WriteLine("Popped off {0}", stackOfPeople.Pop());
    Console.WriteLine("\nFirst person item is: {0}", stackOfPeople.Peek());
    Console.WriteLine("Popped off {0}", stackOfPeople.Pop());

    try
    {
        Console.WriteLine("\n\nFirst person is: {0}", stackOfPeople.Peek());
        Console.WriteLine("Popped off {0}", stackOfPeople.Pop());
    }
    catch (InvalidOperationException ex)
    {
        Console.WriteLine("\nError! {0}", ex.Message);
    }
}
```

Here, you build a stack that contains three people, added in the order of their first names: Homer, Marge, and Lisa. As you peek into the stack, you will always see the object at the top first; therefore, the first call to Peek() reveals the third Person object. After a series of Pop() and Peek() calls, the stack eventually empties, at which time additional Peek() and Pop() calls raise a system exception. You can see the output for this here:

```
***** Fun with Generic Collections *****
First person is: Name: Lisa Simpson, Age: 9
Popped off Name: Lisa Simpson, Age: 9

First person is: Name: Marge Simpson, Age: 45
Popped off Name: Marge Simpson, Age: 45

First person item is: Name: Homer Simpson, Age: 47
Popped off Name: Homer Simpson, Age: 47

Error! Stack empty.
```

Working with the Queue<T> Class

Queues are containers that ensure items are accessed in a first-in, first-out manner. Sadly, we humans are subject to queues all day long: lines at the bank, lines at the movie theater, and lines at the morning coffeehouse. When you need to model a scenario in which items are handled on a first-come, first-served basis, you will find the `Queue<T>` class fits the bill. In addition to the functionality provided by the supported interfaces, `Queue` defines the key members shown in Table 9-6.

Table 9-6. *Members of the Queue<T> Type*

| Select Member of Queue<T> | Meaning in Life |
|---------------------------|--|
| <code>Dequeue()</code> | Removes and returns the object at the beginning of the <code>Queue<T></code> |
| <code>Enqueue()</code> | Adds an object to the end of the <code>Queue<T></code> |
| <code>Peek()</code> | Returns the object at the beginning of the <code>Queue<T></code> without removing it |

Now let's put these methods to work. You can begin by leveraging your `Person` class again and building a `Queue<T>` object that simulates a line of people waiting to order coffee. First, assume you have the following static helper method:

```
static void GetCoffee(Person p)
{
    Console.WriteLine("{0} got coffee!", p.FirstName);
}
```

Now assume you have this additional helper method, which calls `GetCoffee()` internally:

```
static void UseGenericQueue()
{
    // Make a Q with three people.
    Queue<Person> peopleQ = new Queue<Person>();
    peopleQ.Enqueue(new Person {FirstName= "Homer",
        LastName="Simpson", Age=47});
    peopleQ.Enqueue(new Person {FirstName= "Marge",
        LastName="Simpson", Age=45});
    peopleQ.Enqueue(new Person {FirstName= "Lisa",
        LastName="Simpson", Age=9});

    // Peek at first person in Q.
    Console.WriteLine("{0} is first in line!", peopleQ.Peek().FirstName);

    // Remove each person from Q.
    GetCoffee(peopleQ.Dequeue());
    GetCoffee(peopleQ.Dequeue());
    GetCoffee(peopleQ.Dequeue());
}
```

```

// Try to de-Q again?
try
{
    GetCoffee(peopleQ.Dequeue());
}
catch(InvalidOperationException e)
{
    Console.WriteLine("Error! {0}", e.Message);
}
}

```

Here, you insert three items into the `Queue<T>` class using its `Enqueue()` method. The call to `Peek()` allows you to view (but not remove) the first item currently in the `Queue`. Finally, the call to `Dequeue()` removes the item from the line and sends it into the `GetCoffee()` helper function for processing. Note that if you attempt to remove items from an empty queue, a runtime exception is thrown. Here is the output you receive when calling this method:

```
***** Fun with Generic Collections *****
```

```

Homer is first in line!
Homer got coffee!
Marge got coffee!
Lisa got coffee!
Error! Queue empty.

```

Working with the `SortedSet<T>` Class

The `SortedSet<T>` class is useful because it automatically ensures that the items in the set are sorted when you insert or remove items. However, you do need to inform the `SortedSet<T>` class exactly *how* you want it to sort the objects, by passing in as a constructor argument an object that implements the generic `IComparer<T>` interface.

Begin by creating a new class named `SortPeopleByAge`, which implements `IComparer<T>`, where `T` is of type `Person`. Recall that this interface defines a single method named `Compare()`, where you can author whatever logic you require for the comparison. Here is a simple implementation of this class:

```

class SortPeopleByAge : IComparer<Person>
{
    public int Compare(Person firstPerson, Person secondPerson)
    {
        if (firstPerson.Age > secondPerson.Age)
            return 1;
        if (firstPerson.Age < secondPerson.Age)
            return -1;
        else
            return 0;
    }
}

```

Now update your Program class with the following new method, which I assume you will call from Main():

```
static void UseSortedSet()
{
    // Make some people with different ages.
    SortedSet<Person> setOfPeople = new SortedSet<Person>(new SortPeopleByAge())
    {
        new Person {FirstName= "Homer", LastName="Simpson", Age=47},
        new Person {FirstName= "Marge", LastName="Simpson", Age=45},
        new Person {FirstName= "Lisa", LastName="Simpson", Age=9},
        new Person {FirstName= "Bart", LastName="Simpson", Age=8}
    };

    // Note the items are sorted by age!
    foreach (Person p in setOfPeople)
    {
        Console.WriteLine(p);
    }
    Console.WriteLine();

    // Add a few new people, with various ages.
    setOfPeople.Add(new Person { FirstName = "Saku", LastName = "Jones", Age = 1 });
    setOfPeople.Add(new Person { FirstName = "Mikko", LastName = "Jones", Age = 32 });

    // Still sorted by age!
    foreach (Person p in setOfPeople)
    {
        Console.WriteLine(p);
    }
}
```

When you run your application, the listing of objects is now always ordered based on the value of the Age property, regardless of the order you inserted or removed objects.

***** Fun with Generic Collections *****

```
Name: Bart Simpson, Age: 8
Name: Lisa Simpson, Age: 9
Name: Marge Simpson, Age: 45
Name: Homer Simpson, Age: 47
```

```
Name: Saku Jones, Age: 1
Name: Bart Simpson, Age: 8
Name: Lisa Simpson, Age: 9
Name: Mikko Jones, Age: 32
Name: Marge Simpson, Age: 45
Name: Homer Simpson, Age: 47
```

Working with the Dictionary<TKey, TValue> Class

Another handy generic collection is the Dictionary<TKey, TValue> type, which allows you to hold any number of objects that may be referred to via a unique key. Thus, rather than obtaining an item from a List<T> using a numerical identifier (for example, “Give me the second object”), you could use the unique text key (for example, “Give me the object I keyed as Homer”).

Like other collection objects, you can populate a Dictionary<TKey, TValue> by calling the generic Add() method manually. However, you can also fill a Dictionary<TKey, TValue> using collection initialization syntax. Do be aware that when you are populating this collection object, key names must be unique. If you mistakenly specify the same key multiple times, you will receive a runtime exception.

Consider the following method that fills a Dictionary<K, V> with various objects. Notice when you create the Dictionary<TKey, TValue> object, you specify the key type (TKey) and underlying object type (TValue) as constructor arguments. Here, you are using a string data type as the key (although this is not required; the key can be any type) and a Person type as the value.

```
private static void UseDictionary()
{
    // Populate using Add() method
    Dictionary<string, Person> peopleA = new Dictionary<string, Person>();
    peopleA.Add("Homer", new Person { FirstName = "Homer", LastName = "Simpson", Age = 47 });
    peopleA.Add("Marge", new Person { FirstName = "Marge", LastName = "Simpson", Age = 45 });
    peopleA.Add("Lisa", new Person { FirstName = "Lisa", LastName = "Simpson", Age = 9 });

    // Get Homer.
    Person homer = peopleA["Homer"];
    Console.WriteLine(homer);

    // Populate with initialization syntax.
    Dictionary<string, Person> peopleB = new Dictionary<string, Person>()
    {
        { "Homer", new Person { FirstName = "Homer", LastName = "Simpson", Age = 47 } },
        { "Marge", new Person { FirstName = "Marge", LastName = "Simpson", Age = 45 } },
        { "Lisa", new Person { FirstName = "Lisa", LastName = "Simpson", Age = 9 } }
    };

    // Get Lisa.
    Person lisa = peopleB["Lisa"];
    Console.WriteLine(lisa);
}
```

It is also possible to populate a Dictionary<TKey, TValue> using a related initialization syntax introduced with the current version of .NET that is specific to this type of container (not surprisingly termed *dictionary initialization*). Similar to the syntax used to populate the personB object in the previous code example, you still define an initialization scope for the collection object; however, you can use the indexer to specify the key and assign this to a new object as so:

```
// Populate with dictionary initialization syntax.
Dictionary<string, Person> peopleC = new Dictionary<string, Person>()
```



```

{
    ["Homer"] = new Person { FirstName = "Homer", LastName = "Simpson", Age = 47 },
    ["Marge"] = new Person { FirstName = "Marge", LastName = "Simpson", Age = 45 },
    ["Lisa"] = new Person { FirstName = "Lisa", LastName = "Simpson", Age = 9 }
};

```

■ **Note** You can find the `FunWithGenericCollections` project in the Chapter 9 subdirectory.

The System.Collections.ObjectModel Namespace

Now that you understand how to work with the major generic classes, you can briefly examine an additional collection-centric namespace, `System.Collections.ObjectModel`. This is a relatively small namespace, which contains a handful of classes. Table 9-7 documents the two classes that you should most certainly be aware of.

Table 9-7. Useful Members of `System.Collections.ObjectModel`

| <code>System.Collections.ObjectModel</code> Type | Meaning in Life |
|--|---|
| <code>ObservableCollection<T></code> | Represents a dynamic data collection that provides notifications when items get added, removed, or when the whole list is refreshed |
| <code>ReadOnlyObservableCollection<T></code> | Represents a read-only version of <code>ObservableCollection<T></code> |

The `ObservableCollection<T>` class is useful in that it has the ability to inform external objects when its contents have changed in some way (as you might guess, working with `ReadOnlyObservableCollection<T>` is similar but read-only in nature).

Working with `ObservableCollection<T>`

Create a new Console Application project named `FunWithObservableCollection` and import the `System.Collections.ObjectModel` namespace into your initial C# code file. In many ways, working with `ObservableCollection<T>` is identical to working with `List<T>`, given that both of these classes implement the same core interfaces. What makes the `ObservableCollection<T>` class unique is that this class supports an event named `CollectionChanged`. This event will fire whenever a new item is inserted, a current item is removed (or relocated), or the entire collection is modified.

Like any event, `CollectionChanged` is defined in terms of a delegate, which in this case is `NotifyCollectionChangedEventArgs`. This delegate can call any method that takes an object as the first parameter and takes a `NotifyCollectionChangedEventArgs` as the second. Consider the following `Main()` method, which populates an observable collection containing `Person` objects and wires up the `CollectionChanged` event:

```

class Program
{
    static void Main(string[] args)

```

```

{
    // Make a collection to observe and add a few Person objects.
    ObservableCollection<Person> people = new ObservableCollection<Person>()
    {
        new Person{ FirstName = "Peter", LastName = "Murphy", Age = 52 },
        new Person{ FirstName = "Kevin", LastName = "Key", Age = 48 },
    };

    // Wire up the CollectionChanged event.
    people.CollectionChanged += people_CollectionChanged;
}

static void people_CollectionChanged(object sender,
    System.Collections.Specialized.NotifyCollectionChangedEventArgs e)
{
    throw new NotImplementedException();
}
}

```

The incoming `NotifyCollectionChangedEventArgs` parameter defines two important properties, `OldItems` and `NewItems`, which will give you a list of items that were currently in the collection before the event fired and the new items that were involved in the change. However, you will want to examine these lists only under the correct circumstances. Recall that the `CollectionChanged` event can fire when items are added, removed, relocated, or reset. To discover which of these actions triggered the event, you can use the `Action` property of `NotifyCollectionChangedEventArgs`. The `Action` property can be tested against any of the following members of the `NotifyCollectionChangedAction` enumeration:

```

public enum NotifyCollectionChangedAction
{
    Add = 0,
    Remove = 1,
    Replace = 2,
    Move = 3,
    Reset = 4,
}

```

Here is an implementation of the `CollectionChanged` event handler that will traverse the old and new sets when an item has been inserted or removed to the collection at hand:

```

static void people_CollectionChanged(object sender,
    System.Collections.Specialized.NotifyCollectionChangedEventArgs e)
{
    // What was the action that caused the event?
    Console.WriteLine("Action for this event: {0}", e.Action);

    // They removed something.
    if (e.Action == System.Collections.Specialized.NotifyCollectionChangedAction.Remove)
    {
        Console.WriteLine("Here are the OLD items:");
        foreach (Person p in e.OldItems)

```

```

    {
        Console.WriteLine(p.ToString());
    }
    Console.WriteLine();
}

// They added something.
if (e.Action == System.Collections.Specialized.NotifyCollectionChangedAction.Add)
{
    // Now show the NEW items that were inserted.
    Console.WriteLine("Here are the NEW items:");
    foreach (Person p in e.NewItems)
    {
        Console.WriteLine(p.ToString());
    }
}
}
}

```

Now, assuming you have updated your `Main()` method to add and remove an item, you will see output similar to the following:

```

Action for this event: Add
Here are the NEW items:
Name: Fred Smith, Age: 32

```

```

Action for this event: Remove
Here are the OLD items:
Name: Peter Murphy, Age: 52

```

That wraps up the examination of the various collection-centric namespaces in the .NET base class libraries. To conclude the chapter, you will now examine how you can build your own custom generic methods and custom generic types.

■ **Source Code** You can find the `FunWithObservableCollection` project in the [Chapter 9](#) subdirectory.

Creating Custom Generic Methods

While most developers typically use the existing generic types within the base class libraries, it is also possible to build your own generic members and custom generic types. Let's look at how to incorporate custom generics into your own projects. The first step is to build a generic swap method. Begin by creating a new console application named `CustomGenericMethods`.

When you build custom generic methods, you achieve a supercharged version of traditional method overloading. In [Chapter 2](#), you learned that overloading is the act of defining multiple versions of a single method, which differ by the number of, or type of, parameters.

While overloading is a useful feature in an object-oriented language, one problem is that you can easily end up with a ton of methods that essentially do the same thing. For example, assume you need to build some methods that can switch two pieces of data using a simple swap routine. You might begin by authoring a new method that can operate on integers, like this:

```
// Swap two integers.
static void Swap(ref int a, ref int b)
{
    int temp;
    temp = a;
    a = b;
    b = temp;
}
```

So far, so good. But now assume you also need to swap two `Person` objects; this would require authoring a new version of `Swap()`.

```
// Swap two Person objects.
static void Swap(ref Person a, ref Person b)
{
    Person temp;
    temp = a;
    a = b;
    b = temp;
}
```

No doubt, you can see where this is going. If you also needed to swap floating-point numbers, bitmaps, cars, buttons, and whatnot, you would have to build even more methods, which would become a maintenance nightmare. You could build a single (nongeneric) method that operated on object parameters, but then you face all the issues you examined earlier in this chapter, including boxing, unboxing, a lack of type safety, explicit casting, and so on.

Whenever you have a group of overloaded methods that differ only by incoming arguments, this is your clue that generics could make your life easier. Consider the following generic `Swap<T>` method that can swap any two `T`s:

```
// This method will swap any two items.
// as specified by the type parameter <T>.
static void Swap<T>(ref T a, ref T b)
{
    Console.WriteLine("You sent the Swap() method a {0}",
        typeof(T));
    T temp;
    temp = a;
    a = b;
    b = temp;
}
```

Notice how a generic method is defined by specifying the type parameters after the method name but before the parameter list. Here, you state that the `Swap<T>()` method can operate on any two parameters of type `<T>`. To spice things up a bit, you also print out the type name of the supplied placeholder to the console using C#'s `typeof()` operator. Now consider the following `Main()` method, which swaps integers and strings:

```
static void Main(string[] args)
{
    Console.WriteLine("***** Fun with Custom Generic Methods *****\n");

    // Swap 2 ints.
    int a = 10, b = 90;
    Console.WriteLine("Before swap: {0}, {1}", a, b);
    Swap<int>(ref a, ref b);
    Console.WriteLine("After swap: {0}, {1}", a, b);
    Console.WriteLine();

    // Swap 2 strings.
    string s1 = "Hello", s2 = "There";
    Console.WriteLine("Before swap: {0} {1}!", s1, s2);
    Swap<string>(ref s1, ref s2);
    Console.WriteLine("After swap: {0} {1}!", s1, s2);

    Console.ReadLine();
}
```

The output looks like this:

```
***** Fun with Custom Generic Methods *****

Before swap: 10, 90
You sent the Swap() method a System.Int32
After swap: 90, 10

Before swap: Hello There!
You sent the Swap() method a System.String
After swap: There Hello!
```

The major benefit of this approach is that you have only one version of `Swap<T>()` to maintain, yet it can operate on any two items of a given type in a type-safe manner. Better yet, stack-based items stay on the stack, while heap-based items stay on the heap!

Inference of Type Parameters

When you invoke generic methods such as `Swap<T>`, you can optionally omit the type parameter if (and only if) the generic method requires arguments because the compiler can infer the type parameter based on the member parameters. For example, you could swap two `System.Boolean` values by adding the following code to `Main()`:

```
// Compiler will infer System.Boolean.
bool b1 = true, b2 = false;
Console.WriteLine("Before swap: {0}, {1}", b1, b2);
Swap(ref b1, ref b2);
Console.WriteLine("After swap: {0}, {1}", b1, b2);
```

Even though the compiler is able to discover the correct type parameter based on the data type used to declare `b1` and `b2`, you should get in the habit of always specifying the type parameter explicitly.

```
Swap<string>(ref b1, ref b2);
```

This makes it clear to your fellow programmers that this method is indeed generic. Moreover, inference of type parameters works only if the generic method has at least one parameter. For example, assume you have the following generic method in your `Program` class:

```
static void DisplayBaseClass<T>()
{
    // BaseType is a method used in reflection,
    // which will be examined in Chapter 15
    Console.WriteLine("Base class of {0} is: {1}.",
        typeof(T), typeof(T).BaseType);
}
```

In this case, you must supply the type parameter upon invocation.

```
static void Main(string[] args)
{
    ...
    // Must supply type parameter if
    // the method does not take params.
    DisplayBaseClass<int>();
    DisplayBaseClass<string>();

    // Compiler error! No params? Must supply placeholder!
    // DisplayBaseClass();
    Console.ReadLine();
}
```

Currently, the generic `Swap<T>` and `DisplayBaseClass<T>` methods are defined within the application's `Program` class. Of course, as with any method, you are free to define these members in a separate class type (`MyGenericMethods`) if you would prefer to do it that way.

```

public static class MyGenericMethods
{
    public static void Swap<T>(ref T a, ref T b)
    {
        Console.WriteLine("You sent the Swap() method a {0}",
            typeof(T));
        T temp;
        temp = a;
        a = b;
        b = temp;
    }

    public static void DisplayBaseClass<T>()
    {
        Console.WriteLine("Base class of {0} is: {1}.",
            typeof(T), typeof(T).BaseType);
    }
}

```

The static `Swap<T>` and `DisplayBaseClass<T>` methods have been scoped within a new static class type, so you need to specify the type's name when invoking either member, as in this example:

```
MyGenericMethods.Swap<int>(ref a, ref b);
```

Of course, generic methods do not need to be static. If `Swap<T>` and `DisplayBaseClass<T>` were instance level (and defined in a nonstatic class), you would simply make an instance of `MyGenericMethods` and invoke them using the object variable.

```
MyGenericMethods c = new MyGenericMethods();
c.Swap<int>(ref a, ref b);
```

■ **Source Code** You can find the `CustomGenericMethods` project in the [Chapter 9](#) subdirectory.

Creating Custom Generic Structures and Classes

Now that you understand how to define and invoke generic methods, it's time to turn your attention to the construction of a generic structure (the process of building a generic class is identical) within a new Console Application project named `GenericPoint`. Assume you have built a generic `Point` structure that supports a single type parameter that represents the underlying storage for the (x, y) coordinates. The caller can then create `Point<T>` types as follows:

```

// Point using ints.
Point<int> p = new Point<int>(10, 10);

// Point using double.
Point<double> p2 = new Point<double>(5.4, 3.3);

```

Here is the complete definition of `Point<T>`, with some analysis to follow:

```
// A generic Point structure.
public struct Point<T>
{
    // Generic state data.
    private T xPos;
    private T yPos;

    // Generic constructor.
    public Point(T xVal, T yVal)
    {
        xPos = xVal;
        yPos = yVal;
    }

    // Generic properties.
    public T X
    {
        get { return xPos; }
        set { xPos = value; }
    }

    public T Y
    {
        get { return yPos; }
        set { yPos = value; }
    }

    public override string ToString()
    {
        return string.Format("[{0}, {1}]", xPos, yPos);
    }

    // Reset fields to the default value of the
    // type parameter.
    public void ResetPoint()
    {
        xPos = default(T);
        yPos = default(T);
    }
}
```

The default Keyword in Generic Code

As you can see, `Point<T>` leverages its type parameter in the definition of the field data, constructor arguments, and property definitions. Notice that, in addition to overriding `ToString()`, `Point<T>` defines a method named `ResetPoint()` that uses some new syntax you have not yet seen.

```
// The "default" keyword is overloaded in C#.
// When used with generics, it represents the default
// value of a type parameter.
public void ResetPoint()
{
    X = default(T);
    Y = default(T);
}
```

With the introduction of generics, the C# `default` keyword has been given a dual identity. In addition to its use within a `switch` construct, it can also be used to set a type parameter to its default value. This is helpful because a generic type does not know the actual placeholders up front, which means it cannot safely assume what the default value will be. The defaults for a type parameter are as follows:

- Numeric values have a default value of 0.
- Reference types have a default value of `null`.
- Fields of a structure are set to 0 (for value types) or `null` (for reference types).

For `Point<T>`, you can set the `X` and `Y` values to 0 directly because it is safe to assume the caller will supply only numerical data. However, you can also increase the overall flexibility of the generic type by using the `default(T)` syntax. In any case, you can now exercise the methods of `Point<T>`.

```
static void Main(string[] args)
{
    Console.WriteLine("***** Fun with Generic Structures *****\n");

    // Point using ints.
    Point<int> p = new Point<int>(10, 10);
    Console.WriteLine("p.ToString()={0}", p.ToString());
    p.ResetPoint();
    Console.WriteLine("p.ToString()={0}", p.ToString());
    Console.WriteLine();

    // Point using double.
    Point<double> p2 = new Point<double>(5.4, 3.3);
    Console.WriteLine("p2.ToString()={0}", p2.ToString());
    p2.ResetPoint();
    Console.WriteLine("p2.ToString()={0}", p2.ToString());
    Console.ReadLine();
}
```

Here is the output:

```
***** Fun with Generic Structures *****

p.ToString()=[10, 10]
p.ToString()=[0, 0]

p2.ToString()=[5.4, 3.3]
p2.ToString()=[0, 0]
```

■ **Source Code** You can find the `GenericPoint` project in the Chapter 9 subdirectory.

Constraining Type Parameters

As this chapter illustrates, any generic item has at least one type parameter that you need to specify at the time you interact with the generic type or member. This alone allows you to build some type-safe code; however, the .NET platform allows you to use the `where` keyword to get extremely specific about what a given type parameter must look like.

Using this keyword, you can add a set of constraints to a given type parameter, which the C# compiler will check at compile time. Specifically, you can constrain a type parameter as described in Table 9-8.

Table 9-8. Possible Constraints for Generic Type Parameters

| Generic Constraint | Meaning in Life |
|--|---|
| <code>where T : struct</code> | The type parameter <code><T></code> must have <code>System.ValueType</code> in its chain of inheritance (i.e., <code><T></code> must be a structure). |
| <code>where T : class</code> | The type parameter <code><T></code> must not have <code>System.ValueType</code> in its chain of inheritance (i.e., <code><T></code> must be a reference type). |
| <code>where T : new()</code> | The type parameter <code><T></code> must have a default constructor. This is helpful if your generic type must create an instance of the type parameter because you cannot assume you know the format of custom constructors. Note that this constraint must be listed last on a multiconstrained type. |
| <code>where T : NameOfBaseClass</code> | The type parameter <code><T></code> must be derived from the class specified by <code>NameOfBaseClass</code> . |
| <code>where T : NameOfInterface</code> | The type parameter <code><T></code> must implement the interface specified by <code>NameOfInterface</code> . You can separate multiple interfaces as a comma-delimited list. |

Unless you need to build some extremely type-safe custom collections, you might never need to use the `where` keyword in your C# projects. Regardless, the following handful of (partial) code examples illustrate how to work with the `where` keyword.

Examples Using the where Keyword

Begin by assuming that you have created a custom generic class, and you want to ensure that the type parameter has a default constructor. This could be useful when the custom generic class needs to create instances of the T because the default constructor is the only constructor that is potentially common to all types. Also, constraining T in this way lets you get compile-time checking; if T is a reference type, the programmer remembered to redefine the default in the class definition (you might recall that the default constructor is removed in classes when you define your own).

```
// MyGenericClass derives from object, while
// contained items must have a default ctor.
public class MyGenericClass<T> where T : new()
{
    ...
}
```

Notice that the where clause specifies which type parameter is being constrained, followed by a colon operator. After the colon operator, you list each possible constraint (in this case, a default constructor). Here is another example:

```
// MyGenericClass derives from object, while
// contained items must be a class implementing IDrawable
// and must support a default ctor.
public class MyGenericClass<T> where T : class, IDrawable, new()
{
    ...
}
```

In this case, T has three requirements. It must be a reference type (not a structure), as marked with the class token. Second, T must implement the IDrawable interface. Third, it must also have a default constructor. Multiple constraints are listed in a comma-delimited list; however, you should be aware that the new() constraint must always be listed last! Thus, the following code will not compile:

```
// Error! new() constraint must be listed last!
public class MyGenericClass<T> where T : new(), class, IDrawable
{
    ...
}
```

If you ever create a custom generic collection class that specifies multiple type parameters, you can specify a unique set of constraints for each, using separate where clauses.

```
// <K> must extend SomeBaseClass and have a default ctor,
// while <T> must be a structure and implement the
// generic IComparable interface.
public class MyGenericClass<K, T> where K : SomeBaseClass, new()
    where T : struct, IComparable<T>
{
    ...
}
```

You will rarely encounter cases where you need to build a complete custom generic collection class; however, you can use the `where` keyword on generic methods, as well. For example, if you want to specify that your generic `Swap<T>()` method can operate only on structures, you would update the method like this:

```
// This method will swap any structure, but not classes.
static void Swap<T>(ref T a, ref T b) where T : struct
{
    ...
}
```

Note that if you were to constrain the `Swap()` method in this manner, you would no longer be able to swap `string` objects (as is shown in the sample code) because `string` is a reference type.

The Lack of Operator Constraints

I want to make one more comment about generic methods and constraints as this chapter draws to a close. It might come as a surprise to you to find out that when creating generic methods, you will get a compiler error if you apply any C# operators (`+`, `-`, `*`, `==`, etc.) on the type parameters. For example, imagine the usefulness of a class that can add, subtract, multiply, and divide generic types.

```
// Compiler error! Cannot apply
// operators to type parameters!
public class BasicMath<T>
{
    public T Add(T arg1, T arg2)
    { return arg1 + arg2; }
    public T Subtract(T arg1, T arg2)
    { return arg1 - arg2; }
    public T Multiply(T arg1, T arg2)
    { return arg1 * arg2; }
    public T Divide(T arg1, T arg2)
    { return arg1 / arg2; }
}
```

Unfortunately, the preceding `BasicMath` class will not compile. While this might seem like a major restriction, you need to remember that generics are generic. Of course, the numerical data can work just fine with the binary operators of C#. However, for the sake of argument, if `<T>` were a custom class or structure type, the compiler could assume the class supports the `+`, `-`, `*`, and `/` operators. Ideally, C# would allow a generic type to be constrained by supported operators, as in this example:

```
// Illustrative code only!
public class BasicMath<T> where T : operator +, operator -,
    operator *, operator /
{
    public T Add(T arg1, T arg2)
    { return arg1 + arg2; }
    public T Subtract(T arg1, T arg2)
    { return arg1 - arg2; }
    public T Multiply(T arg1, T arg2)
```

```
{ return arg1 * arg2; }  
public T Divide(T arg1, T arg2)  
{ return arg1 / arg2; }  
}
```

Alas, operator constraints are not supported under the current version of C#. However, it is possible (albeit it requires a bit more work) to achieve the desired effect by defining an interface that supports these operators (C# interfaces can define operators!) and then specifying an interface constraint of the generic class. In any case, this wraps up this book's initial look at building custom generic types. In Chapter 10, I will pick up the topic of generics once again in the course of examining the .NET delegate type.

Summary

This chapter began by examining the nongeneric collection types of `System.Collections` and `System.Collections.Specialized`, including the various issues associated with many nongeneric containers, including a lack of type safety and the runtime overhead of boxing and unboxing operations. As mentioned, for these very reasons, modern-day .NET programs will typically make use of the generic collection classes found in `System.Collections.Generic` and `System.Collections.ObjectModel`.

As you have seen, a generic item allows you to specify placeholders (type parameters) that you specify at the time of object creation (or invocation, in the case of generic methods). While you will most often simply use the generic types provided in the .NET base class libraries, you will also be able to create your own generic types (and generic methods). When you do so, you have the option of specifying any number of constraints (using the `where` keyword) to increase the level of type safety and ensure that you perform operations on types of a *known quantity* that are guaranteed to exhibit certain basic capabilities.

As a final note, remember that generics are found in numerous locations within the .NET base class libraries. Here, you focused specifically on generic collections. However, as you work through the remainder of this book (and when you dive into the platform on your own terms), you will certainly find generic classes, structures, and delegates located in a given namespace. As well, be on the lookout for generic members of a nongeneric class!



Delegates, Events, and Lambda Expressions

Up to this point in the text, most of the applications you developed added various bits of code to `Main()`, which, in some way or another, sent requests *to* a given object. However, many applications require that an object be able to communicate *back to* the entity that created it using a callback mechanism. While callback mechanisms can be used in any application, they are especially critical for graphical user interfaces in that controls (such as a button) need to invoke external methods under the correct circumstances (when the button is clicked, when the mouse enters the button surface, and so forth).

Under the .NET platform, the *delegate* type is the preferred means of defining and responding to callbacks within applications. Essentially, the .NET delegate type is a type-safe object that “points to” a method or a list of methods that can be invoked at a later time. Unlike a traditional C++ function pointer, however, .NET delegates are classes that have built-in support for multicasting and asynchronous method invocation.

In this chapter, you will learn how to create and manipulate delegate types, and then you’ll investigate the C# event keyword, which streamlines the process of working with delegate types. Along the way, you will also examine several delegate- and event-centric language features of C#, including anonymous methods and method group conversions.

I wrap up this chapter by examining *lambda expressions*. Using the C# lambda operator (`=>`), you can specify a block of code statements (and the parameters to pass to those code statements) wherever a strongly typed delegate is required. As you will see, a lambda expression is little more than an anonymous method in disguise and provides a simplified approach to working with delegates. In addition, this same operation (as of .NET 4.6) can be used to implement a single-statement method or property using a concise syntax.

Understanding the .NET Delegate Type

Before formally defining .NET delegates, let’s gain a bit of perspective. Historically, the Windows API made frequent use of C-style function pointers to create entities termed *callback functions*, or simply *callbacks*. Using callbacks, programmers were able to configure one function to report back to (call back) another function in the application. With this approach, Windows developers were able to handle button clicking, mouse moving, menu selecting, and general bidirectional communications between two entities in memory.

In the .NET Framework, callbacks are accomplished in a type-safe and object-oriented manner using *delegates*. In essence, a delegate is a type-safe object that points to another method (or possibly a list of methods) in the application, which can be invoked at a later time. Specifically, a delegate maintains three important pieces of information.

- The *address* of the method on which it makes calls
- The *parameters* (if any) of this method
- The *return type* (if any) of this method

■ **Note** .NET delegates can point to either static or instance methods.

After a delegate object has been created and given the necessary information, it may dynamically invoke the method(s) it points to at runtime. Every delegate in the .NET Framework (including your custom delegates) is automatically endowed with the ability to call its methods *synchronously* or *asynchronously*. This fact greatly simplifies programming tasks, given that you can call a method on a secondary thread of execution without manually creating and managing a Thread object.

■ **Note** You will examine the asynchronous behavior of delegate types during your investigation of threading and asynchronous calls in Chapter 19. In this chapter, you are concerned only with the synchronous aspects of the delegate type.

Defining a Delegate Type in C#

When you want to create a delegate type in C#, you use the `delegate` keyword. The name of your delegate type can be whatever you desire. However, you must define the delegate to match the signature of the method(s) it will point to. For example, the following delegate type (named `BinaryOp`) can point to any method that returns an integer and takes two integers as input parameters (you will build and use this delegate yourself a bit later in this chapter, so hang tight for now):

```
// This delegate can point to any method,  
// taking two integers and returning an integer.  
public delegate int BinaryOp(int x, int y);
```

When the C# compiler processes delegate types, it automatically generates a sealed class deriving from `System.MulticastDelegate`. This class (in conjunction with its base class, `System.Delegate`) provides the necessary infrastructure for the delegate to hold onto a list of methods to be invoked at a later time. For example, if you were to examine the `BinaryOp` delegate using `ildasm.exe`, you would find the class shown in Figure 10-1 (you will build this full example in just a moment if you want to check for yourself).

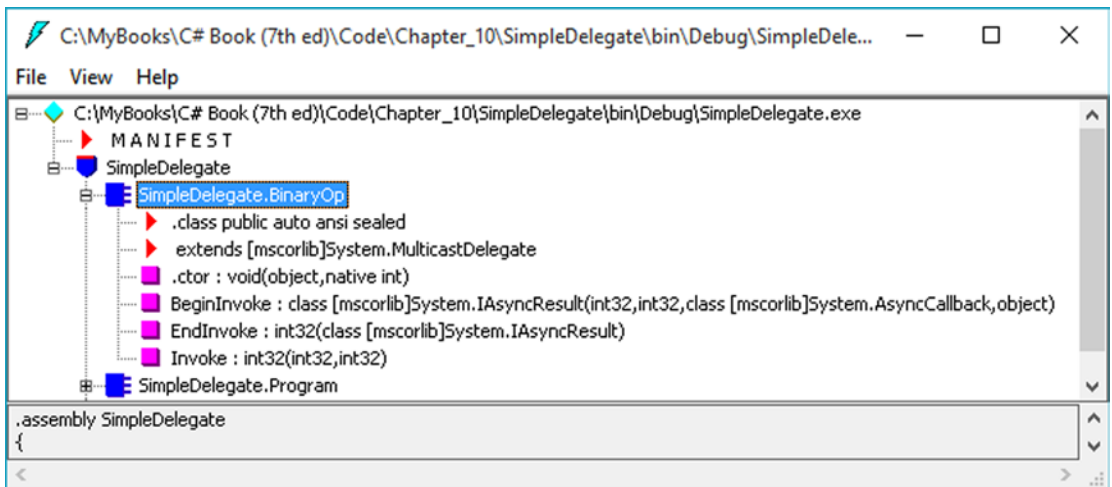

Figure 10-1. The C# delegate keyword represents a sealed class deriving from *System.MulticastDelegate*

As you can see, the compiler-generated `BinaryOp` class defines three public methods. `Invoke()` is perhaps the key method, as it is used to invoke each method maintained by the delegate object in a *synchronous* manner, meaning the caller must wait for the call to complete before continuing on its way. Strangely enough, the synchronous `Invoke()` method may not need to be called explicitly from your C# code. As you will see in just a bit, `Invoke()` is called behind the scenes when you use the appropriate C# syntax.

`BeginInvoke()` and `EndInvoke()` provide the ability to call the current method *asynchronously* on a separate thread of execution. If you have a background in multithreading, you know that one of the most common reasons developers create secondary threads of execution is to invoke methods that require time to complete. Although the .NET base class libraries supply several namespaces devoted to multithreaded and parallel programming, delegates provide this functionality out of the box.

Now, how exactly does the compiler know how to define the `Invoke()`, `BeginInvoke()`, and `EndInvoke()` methods? To understand the process, here is the crux of the compiler-generated `BinaryOp` class type (bold italic marks the items specified by the defined delegate type):

```
sealed class BinaryOp : System.MulticastDelegate
{
    public int Invoke(int x, int y);
    public IAsyncResult BeginInvoke(int x, int y,
        AsyncCallback cb, object state);
    public int EndInvoke(IAsyncResult result);
}
```

First, notice that the parameters and return type defined for the `Invoke()` method exactly match the definition of the `BinaryOp` delegate. The initial parameters to `BeginInvoke()` members (two integers, in this case) are also based on the `BinaryOp` delegate; however, `BeginInvoke()` will always provide two final parameters (of type `AsyncCallback` and `object`) that are used to facilitate asynchronous method invocations. Finally, the return type of `EndInvoke()` is identical to the original delegate declaration and will always take as a sole parameter an object implementing the `IAsyncResult` interface.

Let's see another example. Assume you have defined a delegate type that can point to any method returning a string and receiving three `System.Boolean` input parameters.

```
public delegate string MyDelegate(bool a, bool b, bool c);
```

This time, the compiler-generated class breaks down as follows:

```
sealed class MyDelegate : System.MulticastDelegate
{
    public string Invoke(bool a, bool b, bool c);
    public IAsyncResult BeginInvoke(bool a, bool b, bool c,
        AsyncCallback cb, object state);
    public string EndInvoke(IAsyncResult result);
}
```

Delegates can also “point to” methods that contain any number of out or ref parameters (as well as array parameters marked with the `params` keyword). For example, assume the following delegate type:

```
public delegate string MyOtherDelegate(out bool a, ref bool b, int c);
```

The signatures of the `Invoke()` and `BeginInvoke()` methods look as you would expect; however, check out the following `EndInvoke()` method, which now includes the set of all out/ref arguments defined by the delegate type:

```
public sealed class MyOtherDelegate : System.MulticastDelegate
{
    public string Invoke(out bool a, ref bool b, int c);
    public IAsyncResult BeginInvoke(out bool a, ref bool b, int c,
        AsyncCallback cb, object state);
    public string EndInvoke(out bool a, ref bool b, IAsyncResult result);
}
```

To summarize, a C# delegate type definition results in a sealed class with three compiler-generated methods whose parameter and return types are based on the delegate's declaration. The following pseudocode approximates the basic pattern:

```
// This is only pseudo-code!
public sealed class DelegateName : System.MulticastDelegate
{
    public delegateReturnValue Invoke(allDelegateInputRefAndOutParams);

    public IAsyncResult BeginInvoke(allDelegateInputRefAndOutParams,
        AsyncCallback cb, object state);

    public delegateReturnValue EndInvoke(allDelegateRefAndOutParams,
        IAsyncResult result);
}
```

The System.MulticastDelegate and System.Delegate Base Classes

So, when you build a type using the C# `delegate` keyword, you are indirectly declaring a class type that derives from `System.MulticastDelegate`. This class provides descendants with access to a list that contains the addresses of the methods maintained by the delegate object, as well as several additional methods (and a few overloaded operators) to interact with the invocation list. Here are some select members of `System.MulticastDelegate`:

```
public abstract class MulticastDelegate : Delegate
{
    // Returns the list of methods "pointed to."
    public sealed override Delegate[] GetInvocationList();

    // Overloaded operators.
    public static bool operator ==(MulticastDelegate d1, MulticastDelegate d2);
    public static bool operator !=(MulticastDelegate d1, MulticastDelegate d2);

    // Used internally to manage the list of methods maintained by the delegate.
    private IntPtr _invocationCount;
    private object _invocationList;
}
```

`System.MulticastDelegate` obtains additional functionality from its parent class, `System.Delegate`. Here is a partial snapshot of the class definition:

```
public abstract class Delegate : ICloneable, ISerializable
{
    // Methods to interact with the list of functions.
    public static Delegate Combine(params Delegate[] delegates);
    public static Delegate Combine(Delegate a, Delegate b);
    public static Delegate Remove(Delegate source, Delegate value);
    public static Delegate RemoveAll(Delegate source, Delegate value);

    // Overloaded operators.
    public static bool operator ==(Delegate d1, Delegate d2);
    public static bool operator !=(Delegate d1, Delegate d2);

    // Properties that expose the delegate target.
    public MethodInfo Method { get; }
    public object Target { get; }
}
```

Now, understand that you can never directly derive from these base classes in your code (it is a compiler error to do so). Nevertheless, when you use the `delegate` keyword, you have indirectly created a class that “is-a” `MulticastDelegate`. Table 10-1 documents the core members common to all delegate types.

Table 10-1. *Select Members of System.MulticastDelegate/System.Delegate*

| Member | Meaning in Life |
|--|---|
| Method | This property returns a <code>System.Reflection.MethodInfo</code> object that represents details of a static method maintained by the delegate. |
| Target | If the method to be called is defined at the object level (rather than a static method), <code>Target</code> returns an object that represents the method maintained by the delegate. If the value returned from <code>Target</code> equals <code>null</code> , the method to be called is a static member. |
| <code>Combine()</code> | This static method adds a method to the list maintained by the delegate. In C#, you trigger this method using the overloaded <code>+=</code> operator as a shorthand notation. |
| <code>GetInvocationList()</code> | This method returns an array of <code>System.Delegate</code> objects, each representing a particular method that may be invoked. |
| <code>Remove()</code> <code>RemoveAll()</code> | These static methods remove a method (or all methods) from the delegate's invocation list. In C#, the <code>Remove()</code> method can be called indirectly using the overloaded <code>-=</code> operator. |

The Simplest Possible Delegate Example

To be sure, delegates can cause some confusion when encountered for the first time. Thus, to get the ball rolling, let's take a look at a simple Console Application program (named `SimpleDelegate`) that makes use of the `BinaryOp` delegate type you've seen previously. Here is the complete code, with analysis to follow:

```
namespace SimpleDelegate
{
    // This delegate can point to any method,
    // taking two integers and returning an integer.
    public delegate int BinaryOp(int x, int y);

    // This class contains methods BinaryOp will
    // point to.
    public class SimpleMath
    {
        public static int Add(int x, int y)
        { return x + y; }
        public static int Subtract(int x, int y)
        { return x - y; }
    }

    class Program
    {
        static void Main(string[] args)
        {
            Console.WriteLine("***** Simple Delegate Example *****\n");

            // Create a BinaryOp delegate object that
            // "points to" SimpleMath.Add().
            BinaryOp b = new BinaryOp(SimpleMath.Add);
        }
    }
}
```

```

// Invoke Add() method indirectly using delegate object.
Console.WriteLine("10 + 10 is {0}", b(10, 10));
Console.ReadLine();
    }
}
}

```

Again, notice the format of the `BinaryOp` delegate type declaration; it specifies that `BinaryOp` delegate objects can point to any method taking two integers and returning an integer (the actual name of the method pointed to is irrelevant). Here, you have created a class named `SimpleMath`, which defines two static methods that match the pattern defined by the `BinaryOp` delegate.

When you want to assign the target method to a given delegate object, simply pass in the name of the method to the delegate's constructor.

```

// Create a BinaryOp delegate object that
// "points to" SimpleMath.Add().
BinaryOp b = new BinaryOp(SimpleMath.Add);

```

At this point, you are able to invoke the member pointed to using a syntax that looks like a direct function invocation.

```

// Invoke() is really called here!
Console.WriteLine("10 + 10 is {0}", b(10, 10));

```

Under the hood, the runtime actually calls the compiler-generated `Invoke()` method on your `MulticastDelegate` derived class. You can verify this for yourself if you open your assembly in `ildasm.exe` and examine the CIL code within the `Main()` method.

```

.method private hidebysig static void Main(string[] args) cil managed
{
...
    callvirt instance int32 SimpleDelegate.BinaryOp::Invoke(int32, int32)
}

```

C# does not require you to explicitly call `Invoke()` within your code base. Because `BinaryOp` can point to methods that take two arguments, the following code statement is also permissible:

```

Console.WriteLine("10 + 10 is {0}", b.Invoke(10, 10));

```

Recall that .NET delegates are *type safe*. Therefore, if you attempt to create a delegate object pointing to a method that does not match the pattern, you receive a compile-time error. To illustrate, assume the `SimpleMath` class now defines an additional method named `SquareNumber()`, which takes a single integer as input.

```

public class SimpleMath
{
...
    public static int SquareNumber(int a)
    { return a * a; }
}

```

Given that the `BinaryOp` delegate can point *only* to methods that take two integers and return an integer, the following code is illegal and will not compile:

```
// Compiler error! Method does not match delegate pattern!
BinaryOp b2 = new BinaryOp(SimpleMath.SquareNumber);
```

Investigating a Delegate Object

Let's spice up the current example by creating a static method (named `DisplayDelegateInfo()`) within the `Program` class. This method will print out the names of the methods maintained by a delegate object, as well as the name of the class defining the method. To do this, you will iterate over the `System.Delegate` array returned by `GetInvocationList()`, invoking each object's `Target` and `Method` properties.

```
static void DisplayDelegateInfo(Delegate delObj)
{
    // Print the names of each member in the
    // delegate's invocation list.
    foreach (Delegate d in delObj.GetInvocationList())
    {
        Console.WriteLine("Method Name: {0}", d.Method);
        Console.WriteLine("Type Name: {0}", d.Target);
    }
}
```

Assuming you have updated your `Main()` method to actually call this new helper method, as shown here:

```
BinaryOp b = new BinaryOp(SimpleMath.Add);
DisplayDelegateInfo(b);
```

you would find the output shown next:

```
***** Simple Delegate Example *****
```

```
Method Name: Int32 Add(Int32, Int32)
Type Name:
10 + 10 is 20
```

Notice that the name of the target class (`SimpleMath`) is currently *not* displayed when calling the `Target` property. The reason has to do with the fact that your `BinaryOp` delegate is pointing to a *static method* and, therefore, there is no object to reference! However, if you update the `Add()` and `Subtract()` methods to be nonstatic (simply by deleting the `static` keywords), you could create an instance of the `SimpleMath` class and specify the methods to invoke using the object reference.

```

static void Main(string[] args)
{
    Console.WriteLine("***** Simple Delegate Example *****\n");

    // .NET delegates can also point to instance methods as well.
    SimpleMath m = new SimpleMath();
    BinaryOp b = new BinaryOp(m.Add);

    // Show information about this object.
    DisplayDelegateInfo(b);

    Console.WriteLine("10 + 10 is {0}", b(10, 10));
    Console.ReadLine();
}

```

In this case, you would find the output shown here:

```

***** Simple Delegate Example *****

Method Name: Int32 Add(Int32, Int32)
Type Name: SimpleDelegate.SimpleMath
10 + 10 is 20

```

■ **Note** The SimpleDelegate project is located in the [Chapter 10](#) subdirectory.

Sending Object State Notifications Using Delegates

Clearly, the previous SimpleDelegate example was intended to be purely illustrative in nature, given that there would be no compelling reason to define a delegate simply to add two numbers. To provide a more realistic use of delegate types, let's use delegates to define a Car class that has the ability to inform external entities about its current engine state. To do so, you will take the following steps:

1. Define a new delegate type that will be used to send notifications to the caller.
2. Declare a member variable of this delegate in the Car class.
3. Create a helper function on the Car that allows the caller to specify the method to call back on.
4. Implement the Accelerate() method to invoke the delegate's invocation list under the correct circumstances.

To begin, create a new Console Application project named CarDelegate. Now, define a new Car class that looks initially like this:

```
public class Car
{
    // Internal state data.
    public int CurrentSpeed { get; set; }
    public int MaxSpeed { get; set; } = 100;
    public string PetName { get; set; }

    // Is the car alive or dead?
    private bool carIsDead;

    // Class constructors.
    public Car() {}
    public Car(string name, int maxSp, int currSp)
    {
        CurrentSpeed = currSp;
        MaxSpeed = maxSp;
        PetName = name;
    }
}
```

Now, consider the following updates, which address the first three points:

```
public class Car
{
    ...
    // 1) Define a delegate type.
    public delegate void CarEngineHandler(string msgForCaller);

    // 2) Define a member variable of this delegate.
    private CarEngineHandler listOfHandlers;

    // 3) Add registration function for the caller.
    public void RegisterWithCarEngine(CarEngineHandler methodToCall)
    {
        listOfHandlers = methodToCall;
    }
}
```

Notice in this example that you define the delegate types directly within the scope of the Car class, which is certainly not necessary but does help enforce the idea that the delegate works naturally with this particular class. The delegate type, CarEngineHandler, can point to any method taking a single string as input and void as a return value.

Next, note that you declare a private member variable of your delegate type (named listOfHandlers) and a helper function (named RegisterWithCarEngine()) that allows the caller to assign a method to the delegate's invocation list.

■ **Note** Strictly speaking, you could have defined your delegate member variable as public, therefore avoiding the need to create additional registration methods. However, by defining the delegate member variable as private, you are enforcing encapsulation services and providing a more type-safe solution. You'll revisit the risk of public delegate member variables later in this chapter when you look at the C# event keyword.

At this point, you need to create the `Accelerate()` method. Recall, the point here is to allow a `Car` object to send engine-related messages to any subscribed listener. Here is the update:

// 4) Implement the Accelerate() method to invoke the delegate's invocation list under the correct circumstances.

```
public void Accelerate(int delta)
{
    // If this car is "dead," send dead message.
    if (carIsDead)
    {
        if (listOfHandlers != null)
            listOfHandlers("Sorry, this car is dead...");
    }
    else
    {
        CurrentSpeed += delta;

        // Is this car "almost dead"?
        if (10 == (MaxSpeed - CurrentSpeed)
            && listOfHandlers != null)
        {
            listOfHandlers("Careful buddy! Gonna blow!");
        }
        if (CurrentSpeed >= MaxSpeed)
            carIsDead = true;
        else
            Console.WriteLine("CurrentSpeed = {0}", CurrentSpeed);
    }
}
```

Notice that before you invoke the methods maintained by the `listOfHandlers` member variable, you are checking it against a null value. The reason is that it will be the job of the caller to allocate these objects by calling the `RegisterWithCarEngine()` helper method. If the caller does not call this method and you attempt to invoke the delegate's invocation list, you will trigger a `NullReferenceException` at runtime. Now that you have the delegate infrastructure in place, observe the updates to the `Program` class:

```
class Program
{
    static void Main(string[] args)
    {
        Console.WriteLine("***** Delegates as event enablers *****\n");

        // First, make a Car object.
        Car c1 = new Car("SlugBug", 100, 10);
```



```

// Now, tell the car which method to call
// when it wants to send us messages.
c1.RegisterWithCarEngine(new Car.CarEngineHandler(OnCarEngineEvent));

// Speed up (this will trigger the events).
Console.WriteLine("***** Speeding up *****");
for (int i = 0; i < 6; i++)
    c1.Accelerate(20);
Console.ReadLine();
}

// This is the target for incoming events.
public static void OnCarEngineEvent(string msg)
{
    Console.WriteLine("\n***** Message From Car Object *****");
    Console.WriteLine("=> {0}", msg);
    Console.WriteLine("*****\n");
}
}

```

The `Main()` method begins by simply making a new `Car` object. Since you are interested in hearing about the engine events, the next step is to call your custom registration function, `RegisterWithCarEngine()`. Recall that this method expects to be passed an instance of the nested `CarEngineHandler` delegate, and as with any delegate, you specify a “method to point to” as a constructor parameter. The trick in this example is that the method in question is located back in the `Program` class! Again, notice that the `OnCarEngineEvent()` method is a dead-on match to the related delegate in that it takes a string as input and returns `void`. Consider the output of the current example:

```

***** Delegates as event enablers *****
***** Speeding up *****
CurrentSpeed = 30
CurrentSpeed = 50
CurrentSpeed = 70

***** Message From Car Object *****
=> Careful buddy! Gonna blow!
*****
CurrentSpeed = 90
***** Message From Car Object *****
=> Sorry, this car is dead..
*****

```

Enabling Multicasting

Recall that .NET delegates have the built-in ability to *multicast*. In other words, a delegate object can maintain a list of methods to call, rather than just a single method. When you want to add multiple methods to a delegate object, you simply use the overloaded `+=` operator, rather than a direct assignment. To enable multicasting on the `Car` class, you could update the `RegisterWithCarEngine()` method, like so:

```

public class Car
{
    // Now with multicasting support!
    // Note we are now using the += operator, not
    // the assignment operator (=).
    public void RegisterWithCarEngine(CarEngineHandler methodToCall)
    {
        listOfHandlers += methodToCall;
    }
    ...
}

```

When you use the += operator on a delegate object, the compiler resolves this to a call on the static `Delegate.Combine()` method. In fact, you could call `Delegate.Combine()` directly; however, the += operator offers a simpler alternative. There is no need to modify your current `RegisterWithCarEngine()` method, but here is an example if using `Delegate.Combine()` rather than the += operator:

```

public void RegisterWithCarEngine( CarEngineHandler methodToCall )
{
    if (listOfHandlers == null)
        listOfHandlers = methodToCall;
    else
        Delegate.Combine(listOfHandlers, methodToCall);
}

```

In any case, the caller can now register multiple targets for the same callback notification. Here, the second handler prints the incoming message in uppercase, just for display purposes:

```

class Program
{
    static void Main(string[] args)
    {
        Console.WriteLine("***** Delegates as event enablers *****\n");

        // First, make a Car object.
        Car c1 = new Car("SlugBug", 100, 10);

        // Register multiple targets for the notifications.
        c1.RegisterWithCarEngine(new Car.CarEngineHandler(OnCarEngineEvent));
        c1.RegisterWithCarEngine(new Car.CarEngineHandler(OnCarEngineEvent2));

        // Speed up (this will trigger the events).
        Console.WriteLine("***** Speeding up *****");
        for (int i = 0; i < 6; i++)
            c1.Accelerate(20);
        Console.ReadLine();
    }
}

```

```

// We now have TWO methods that will be called by the Car
// when sending notifications.
public static void OnCarEngineEvent(string msg)
{
    Console.WriteLine("\n***** Message From Car Object *****");
    Console.WriteLine("=> {0}", msg);
    Console.WriteLine("*****\n");
}

public static void OnCarEngineEvent2(string msg)
{
    Console.WriteLine("=> {0}", msg.ToUpper());
}
}

```

Removing Targets from a Delegate's Invocation List

The Delegate class also defines a static Remove() method that allows a caller to dynamically remove a method from a delegate object's invocation list. This makes it simple to allow the caller to “unsubscribe” from a given notification at runtime. While you could call Delegate.Remove() directly in code, C# developers can use the -= operator as a convenient shorthand notation. Let's add a new method to the Car class that allows a caller to remove a method from the invocation list.

```

public class Car
{
    ...
    public void UnRegisterWithCarEngine(CarEngineHandler methodToCall)
    {
        listOfHandlers -= methodToCall;
    }
}

```

With the current updates to the Car class, you could stop receiving the engine notification on the second handler by updating Main() as follows:

```

static void Main(string[] args)
{
    Console.WriteLine("***** Delegates as event enablers *****\n");

    // First, make a Car object.
    Car c1 = new Car("SlugBug", 100, 10);
    c1.RegisterWithCarEngine(new Car.CarEngineHandler(OnCarEngineEvent));

    // This time, hold onto the delegate object,
    // so we can unregister later.
    Car.CarEngineHandler handler2 = new Car.CarEngineHandler(OnCarEngineEvent2);
    c1.RegisterWithCarEngine(handler2);
}

```

```

// Speed up (this will trigger the events).
Console.WriteLine("***** Speeding up *****");
for (int i = 0; i < 6; i++)
    c1.Accelerate(20);

// Unregister from the second handler.
c1.UnRegisterWithCarEngine(handler2);

// We won't see the "uppercase" message anymore!
Console.WriteLine("***** Speeding up *****");
for (int i = 0; i < 6; i++)
    c1.Accelerate(20);

Console.ReadLine();
}

```

One difference in `Main()` is that this time you are creating a `Car.CarEngineHandler` object and storing it in a local variable so you can use this object to unregister with the notification later. Thus, the second time you speed up the `Car` object, you no longer see the uppercase version of the incoming message data, as you have removed this target from the delegate's invocation list.

■ **Source Code** The `CarDelegate` project is located in the Chapter 10 subdirectory.

Method Group Conversion Syntax

In the previous `CarDelegate` example, you explicitly created instances of the `Car.CarEngineHandler` delegate object to register and unregister with the engine notifications.

```

static void Main(string[] args)
{
    Console.WriteLine("***** Delegates as event enablers *****\n");

    Car c1 = new Car("SlugBug", 100, 10);
    c1.RegisterWithCarEngine(new Car.CarEngineHandler(OnCarEngineEvent));

    Car.CarEngineHandler handler2 =
    new Car.CarEngineHandler(OnCarEngineEvent2);
    c1.RegisterWithCarEngine(handler2);
    ...
}

```

To be sure, if you need to call any of the inherited members of `MulticastDelegate` or `Delegate`, manually creating a delegate variable is the most straightforward way of doing so. However, in most cases, you don't really need to hang onto the delegate object. Rather, you typically need to use the delegate object only to pass in the method name as a constructor parameter.

As a simplification, `C#` provides a shortcut termed *method group conversion*. This feature allows you to supply a direct method name, rather than a delegate object, when calling methods that take delegates as arguments.

■ **Note** As you will see later in this chapter, you can also use method group conversion syntax to simplify how you register with a C# event.

To illustrate, create a new Console Application project named `CarDelegateMethodGroupConversion` and insert the file containing the `Car` class you defined in the `CarDelegate` project (and update the namespace name in the `Car.cs` file to match your new namespace name). Now, consider the following Program class, which uses method group conversion to register and unregister from the engine notifications:

```
class Program
{
    static void Main(string[] args)
    {
        Console.WriteLine("***** Method Group Conversion *****\n");
        Car c1 = new Car();

        // Register the simple method name.
        c1.RegisterWithCarEngine(CallMeHere);

        Console.WriteLine("***** Speeding up *****");
        for (int i = 0; i < 6; i++)
            c1.Accelerate(20);

        // Unregister the simple method name.
        c1.UnRegisterWithCarEngine(CallMeHere);

        // No more notifications!
        for (int i = 0; i < 6; i++)
            c1.Accelerate(20);

        Console.ReadLine();
    }

    static void CallMeHere(string msg)
    {
        Console.WriteLine("=> Message from Car: {0}", msg);
    }
}
```

Notice that you are not directly allocating the associated delegate object but rather simply specifying a method that matches the delegate's expected signature (a method returning `void` and taking a single `string`, in this case). Understand that the C# compiler is still ensuring type safety. Thus, if the `CallMeHere()` method did not take a `string` and return `void`, you would be issued a compiler error.

■ **Source Code** The `CarDelegateMethodGroupConversion` project is located in the [Chapter 10](#) subdirectory.

Understanding Generic Delegates

In the previous chapter, I mentioned that C# allows you to define generic delegate types. For example, assume you want to define a delegate type that can call any method returning `void` and receiving a single parameter. If the argument in question may differ, you could model this using a type parameter. To illustrate, consider the following code within a new Console Application project named `GenericDelegate`:

```
namespace GenericDelegate
{
    // This generic delegate can represent any method
    // returning void and taking a single parameter of type T.
    public delegate void MyGenericDelegate<T>(T arg);

    class Program
    {
        static void Main(string[] args)
        {
            Console.WriteLine("***** Generic Delegates *****\n");

            // Register targets.
            MyGenericDelegate<string> strTarget =
                new MyGenericDelegate<string>(StringTarget);
            strTarget("Some string data");

            MyGenericDelegate<int> intTarget =
                new MyGenericDelegate<int>(IntTarget);
            intTarget(9);
            Console.ReadLine();
        }

        static void StringTarget(string arg)
        {
            Console.WriteLine("arg in uppercase is: {0}", arg.ToUpper());
        }

        static void IntTarget(int arg)
        {
            Console.WriteLine("++arg is: {0}", ++arg);
        }
    }
}
```

Notice that `MyGenericDelegate<T>` defines a single type parameter that represents the argument to pass to the delegate target. When creating an instance of this type, you are required to specify the value of the type parameter, as well as the name of the method the delegate will invoke. Thus, if you specified a string type, you send a string value to the target method.

```
// Create an instance of MyGenericDelegate<T>
// with string as the type parameter.
MyGenericDelegate<string> strTarget =
    new MyGenericDelegate<string>(StringTarget);
strTarget("Some string data");
```

Given the format of the `strTarget` object, the `StringTarget()` method must now take a single string as a parameter.

```
static void StringTarget(string arg)
{
    Console.WriteLine("arg in uppercase is: {0}", arg.ToUpper());
}
```

■ **Source Code** The `GenericDelegate` project is located in the [Chapter 10](#) subdirectory.

The Generic `Action<>` and `Func<>` Delegates

Over the course of this chapter, you have seen that when you want to use delegates to enable callbacks in your applications, you typically follow the steps shown here:

- Define a custom delegate that matches the format of the method being pointed to.
- Create an instance of your custom delegate, passing in a method name as a constructor argument.
- Invoke the method indirectly, via a call to `Invoke()` on the delegate object.

When you take this approach, you typically end up with a number of custom delegates that might never be used beyond the current task at hand (e.g., `MyGenericDelegate<T>`, `CarEngineHandler`, and so forth). While it may certainly be the case that you do indeed need to have a custom, uniquely named delegate type for your project, other times the exact *name* of the delegate type is irrelevant. In many cases, you simply want “some delegate” that takes a set of arguments and possibly has a return value other than `void`. In these cases, you can use the framework’s built-in `Action<>` and `Func<>` delegate types. To illustrate their usefulness, create a new Console Application project named `ActionAndFuncDelegates`.

The generic `Action<>` delegate is defined in the `System` namespaces of `microsoft.dll` and `System.Core.dll` assemblies. You can use this generic delegate to “point to” a method that takes up to *16 arguments* (that ought to be enough!) and returns `void`. Now recall, because `Action<>` is a generic delegate, you will need to specify the underlying types of each parameter as well.

Update your `Program` class to define a new static method that takes three (or so) unique parameters. Here’s an example:

```
// This is a target for the Action<> delegate.
static void DisplayMessage(string msg, ConsoleColor txtColor, int printCount)
{
    // Set color of console text.
    ConsoleColor previous = Console.ForegroundColor;
    Console.ForegroundColor = txtColor;

    for (int i = 0; i < printCount; i++)
    {
        Console.WriteLine(msg);
    }

    // Restore color.
    Console.ForegroundColor = previous;
}
```

Now, rather than building a custom delegate manually to pass the program's flow to the `DisplayMessage()` method, you can use the out-of-the-box `Action<>` delegate, as so:

```
static void Main(string[] args)
{
    Console.WriteLine("***** Fun with Action and Func *****");

    // Use the Action<> delegate to point to DisplayMessage.
    Action<string, ConsoleColor, int> actionTarget =
        new Action<string, ConsoleColor, int>(DisplayMessage);
    actionTarget("Action Message!", ConsoleColor.Yellow, 5);

    Console.ReadLine();
}
```

As you can see, using the `Action<>` delegate saves you the bother of defining a custom delegate type. However, recall that the `Action<>` delegate type can point only to methods that take a void return value. If you want to point to a method that does have a return value (and don't want to bother writing the custom delegate yourself), you can use `Func<>`.

The generic `Func<>` delegate can point to methods that (like `Action<>`) take up to 16 parameters and a custom return value. To illustrate, add the following new method to the `Program` class:

```
// Target for the Func<> delegate.
static int Add(int x, int y)
{
    return x + y;
}
```

Earlier in the chapter, I had you build a custom `BinaryOp` delegate to “point to” addition and subtraction methods. However, you can simplify your efforts using a version of `Func<>` that takes a total of three type parameters. Be aware that the *final* type parameter of `Func<>` is *always* the return value of the method. Just to solidify that point, assume the `Program` class also defines the following method:

```
static string SumToString(int x, int y)
{
    return (x + y).ToString();
}
```

Now, the `Main()` method can call each of these methods, as so:

```
Func<int, int, int> funcTarget = new Func<int, int, int>(Add);
int result = funcTarget.Invoke(40, 40);
Console.WriteLine("40 + 40 = {0}", result);

Func<int, int, string> funcTarget2 = new Func<int, int, string>(SumToString);
string sum = funcTarget2(90, 300);
Console.WriteLine(sum);
```

Also recall method group conversion syntax would allow you to simplify the previous code to the following:

```
Func<int, int, int> funcTarget = Add;
int result = funcTarget.Invoke(40, 40);
Console.WriteLine("40 + 40 = {0}", result);

Func<int, int, string> funcTarget2 = SumToString;
string sum = funcTarget2(90, 300);
Console.WriteLine(sum);
```

In any case, given that `Action<>` and `Func<>` can save you the step of manually defining a custom delegate, you might be wondering if you should use them all the time. The answer, like so many aspects of programming, is “it depends.” In many cases, `Action<>` and `Func<>` will be the preferred course of action (no pun intended). However, if you need a delegate that has a custom name that you feel helps better capture your problem domain, building a custom delegate is as simple as a single code statement. You’ll see both approaches as you work over the remainder of this text.

■ **Note** Many important .NET APIs make considerable use of `Action<>` and `Func<>` delegates, including the parallel programming framework and LINQ (among others).

That wraps up our initial look at the .NET delegate type. You will look at some additional details of working with delegates at the conclusion of this chapter and again in Chapter 19 during your examination of multithreading and asynchronous calls. Next, let’s move on to the related topic of the C# event keyword.

■ **Source Code** The `ActionAndFuncDelegates` project is located in the Chapter 10 subdirectory.

Understanding C# Events

Delegates are fairly interesting constructs in that they enable objects in memory to engage in a two-way conversation. However, working with delegates in the raw can entail the creation of some boilerplate code (defining the delegate, declaring necessary member variables, and creating custom registration and unregistration methods to preserve encapsulation, etc.).

Moreover, when you use delegates in the raw as your application’s callback mechanism, if you do not define a class’s delegate member variables as private, the caller will have direct access to the delegate objects. In this case, the caller could reassign the variable to a new delegate object (effectively deleting the current list of functions to call), and, worse yet, the caller would be able to directly invoke the delegate’s invocation list. To illustrate this problem, consider the following reworking (and simplification) of the `Car` class from the previous `CarDelegate` example:

```
public class Car
{
    public delegate void CarEngineHandler(string msgForCaller);

    // Now a public member!
    public CarEngineHandler listOfHandlers;
```

```

// Just fire out the Exploded notification.
public void Accelerate(int delta)
{
    if (listOfHandlers != null)
        listOfHandlers("Sorry, this car is dead...");
}
}

```

Notice that you no longer have private delegate member variables encapsulated with custom registration methods. Because these members are indeed public, the caller can directly access the `listOfHandlers` member variable and reassign this type to new `CarEngineHandler` objects and invoke the delegate whenever it so chooses.

```

class Program
{
    static void Main(string[] args)
    {
        Console.WriteLine("***** Agh! No Encapsulation! *****\n");
        // Make a Car.
        Car myCar = new Car();
        // We have direct access to the delegate!
        myCar.listOfHandlers = new Car.CarEngineHandler(CallWhenExploded);
        myCar.Accelerate(10);

        // We can now assign to a whole new object...
        // confusing at best.
        myCar.listOfHandlers = new Car.CarEngineHandler(CallHereToo);
        myCar.Accelerate(10);

        // The caller can also directly invoke the delegate!
        myCar.listOfHandlers.Invoke("hee, hee, hee...");
        Console.ReadLine();
    }

    static void CallWhenExploded(string msg)
    { Console.WriteLine(msg); }

    static void CallHereToo(string msg)
    { Console.WriteLine(msg); }
}

```

Exposing public delegate members breaks encapsulation, which not only can lead to code that is hard to maintain (and debug) but could also open your application to possible security risks! Here is the output of the current example:

```
***** Agh! No Encapsulation! *****
```

```

Sorry, this car is dead...
Sorry, this car is dead...
hee, hee, hee...

```

Obviously, you would not want to give other applications the power to change what a delegate is pointing to or to invoke the members without your permission. Given this, it is common practice to declare private delegate member variables.

■ **Source Code** The `PublicDelegateProblem` project is located in the [Chapter 10](#) subdirectory.

The C# event Keyword

As a shortcut, so you don't have to build custom methods to add or remove methods to a delegate's invocation list, C# provides the event keyword. When the compiler processes the event keyword, you are automatically provided with registration and unregistration methods, as well as any necessary member variables for your delegate types. These delegate member variables are *always* declared private, and, therefore, they are not directly exposed from the object firing the event. To be sure, the event keyword can be used to simplify how a custom class sends out notifications to external objects.

Defining an event is a two-step process. First, you need to define a delegate type (or reuse an existing one) that will hold the list of methods to be called when the event is fired. Next, you declare an event (using the C# event keyword) in terms of the related delegate type.

To illustrate the event keyword, create a new Console Application named `CarEvents`. In this iteration of the `Car` class, you will define two events named `AboutToBlow` and `Exploded`. These events are associated to a single delegate type named `CarEngineHandler`. Here are the initial updates to the `Car` class:

```
public class Car
{
    // This delegate works in conjunction with the
    // Car's events.
    public delegate void CarEngineHandler(string msg);

    // This car can send these events.
    public event CarEngineHandler Exploded;
    public event CarEngineHandler AboutToBlow;
    ...
}
```

Sending an event to the caller is as simple as specifying the event by name, along with any required parameters as defined by the associated delegate. To ensure that the caller has indeed registered with the event, you will want to check the event against a null value before invoking the delegate's method set. With these points in mind, here is the new iteration of the `Car`'s `Accelerate()` method:

```
public void Accelerate(int delta)
{
    // If the car is dead, fire Exploded event.
    if (carIsDead)
    {
        if (Exploded != null)
            Exploded("Sorry, this car is dead...");
    }
    else
    {
        CurrentSpeed += delta;
    }
}
```

```

// Almost dead?
if (10 == MaxSpeed - CurrentSpeed
    && AboutToBlow != null)
{
    AboutToBlow("Careful buddy! Gonna blow!");
}

// Still OK!
if (CurrentSpeed >= MaxSpeed)
    carIsDead = true;
else
    Console.WriteLine("CurrentSpeed = {0}", CurrentSpeed);
}
}

```

With this, you have configured the car to send two custom events without having to define custom registration functions or declare delegate member variables. You will see the usage of this new automobile in just a moment, but first let's check the event architecture in a bit more detail.

Events Under the Hood

When the compiler processes the C# event keyword, it generates two hidden methods, one having an `add_` prefix and the other having a `remove_` prefix. Each prefix is followed by the name of the C# event. For example, the `Exploded` event results in two hidden methods named `add_Exploded()` and `remove_Exploded()`. If you were to check out the CIL instructions behind `add_AboutToBlow()`, you would find a call to the `Delegate.Combine()` method. Consider the partial CIL code:

```

.method public hidebysig specialname instance void
add_AboutToBlow(class CarEvents.Car/CarEngineHandler 'value') cil managed
{
    ...
    call class [mscorlib]System.Delegate
    [mscorlib]System.Delegate::Combine(
        class [mscorlib]System.Delegate, class [mscorlib]System.Delegate)
    ...
}

```

As you would expect, `remove_AboutToBlow()` will call `Delegate.Remove()` on your behalf.

```

.method public hidebysig specialname instance void
remove_AboutToBlow(class CarEvents.Car/CarEngineHandler 'value')
    cil managed
{
    ...
    call class [mscorlib]System.Delegate
    [mscorlib]System.Delegate::Remove(
        class [mscorlib]System.Delegate, class [mscorlib]System.Delegate)
    ...
}

```

Finally, the CIL code representing the event itself makes use of the `.addon` and `.removeon` directives to map the names of the correct `add_XXX()` and `remove_XXX()` methods to invoke.

```
.event CarEvents.Car/EngineHandler AboutToBlow
{
    .addon instance void CarEvents.Car::add_AboutToBlow
        (class CarEvents.Car/CarEngineHandler)

    .removeon instance void CarEvents.Car::remove_AboutToBlow
        (class CarEvents.Car/CarEngineHandler)
}
```

Now that you understand how to build a class that can send C# events (and are aware that events are little more than a typing time-saver), the next big question is how to listen to the incoming events on the caller's side.

Listening to Incoming Events

C# events also simplify the act of registering the caller-side event handlers. Rather than having to specify custom helper methods, the caller simply uses the `+=` and `-=` operators directly (which triggers the correct `add_XXX()` or `remove_XXX()` method in the background). When you want to register with an event, follow the pattern shown here:

```
// NameOfObject.NameOfEvent += new RelatedDelegate(functionToCall);
//
Car.CarEngineHandler d = new Car.CarEngineHandler(CarExplodedEventHandler);
myCar.Exploded += d;
```

When you want to detach from a source of events, use the `-=` operator, using the following pattern:

```
// NameOfObject.NameOfEvent -= new RelatedDelegate(functionToCall);
//
myCar.Exploded -= d;
```

Given these very predictable patterns, here is the refactored `Main()` method, now using the C# event registration syntax:

```
class Program
{
    static void Main(string[] args)
    {
        Console.WriteLine("***** Fun with Events *****\n");
        Car c1 = new Car("SlugBug", 100, 10);

        // Register event handlers.
        c1.AboutToBlow += new Car.CarEngineHandler(CarIsAlmostDoomed);
        c1.AboutToBlow += new Car.CarEngineHandler(CarAboutToBlow);

        Car.CarEngineHandler d = new Car.CarEngineHandler(CarExploded);
        c1.Exploded += d;
```

```

Console.WriteLine("***** Speeding up *****");
for (int i = 0; i < 6; i++)
    c1.Accelerate(20);

// Remove CarExploded method
// from invocation list.
c1.Exploded -= d;

Console.WriteLine("\n***** Speeding up *****");
for (int i = 0; i < 6; i++)
    c1.Accelerate(20);
Console.ReadLine();
}

public static void CarAboutToBlow(string msg)
{ Console.WriteLine(msg); }

public static void CarIsAlmostDoomed(string msg)
{ Console.WriteLine("=> Critical Message from Car: {0}", msg); }

public static void CarExploded(string msg)
{ Console.WriteLine(msg); }
}

```

To even further simplify event registration, you can use method group conversion. Consider the following iteration of `Main()`:

```

static void Main(string[] args)
{
    Console.WriteLine("***** Fun with Events *****\n");
    Car c1 = new Car("SlugBug", 100, 10);
    // Register event handlers.
    c1.AboutToBlow += CarIsAlmostDoomed;
    c1.AboutToBlow += CarAboutToBlow;
    c1.Exploded += CarExploded;

    Console.WriteLine("***** Speeding up *****");
    for (int i = 0; i < 6; i++)
        c1.Accelerate(20);

    c1.Exploded -= CarExploded;

    Console.WriteLine("\n***** Speeding up *****");
    for (int i = 0; i < 6; i++)
        c1.Accelerate(20);

    Console.ReadLine();
}

```

Simplifying Event Registration Using Visual Studio

Visual Studio offers assistance with the process of registering event handlers. When you apply the += syntax during event registration, you will find an IntelliSense window displayed, inviting you to hit the Tab key to autocomplete the associated delegate instance (see Figure 10-2), which is captured using *method group conversion syntax*.

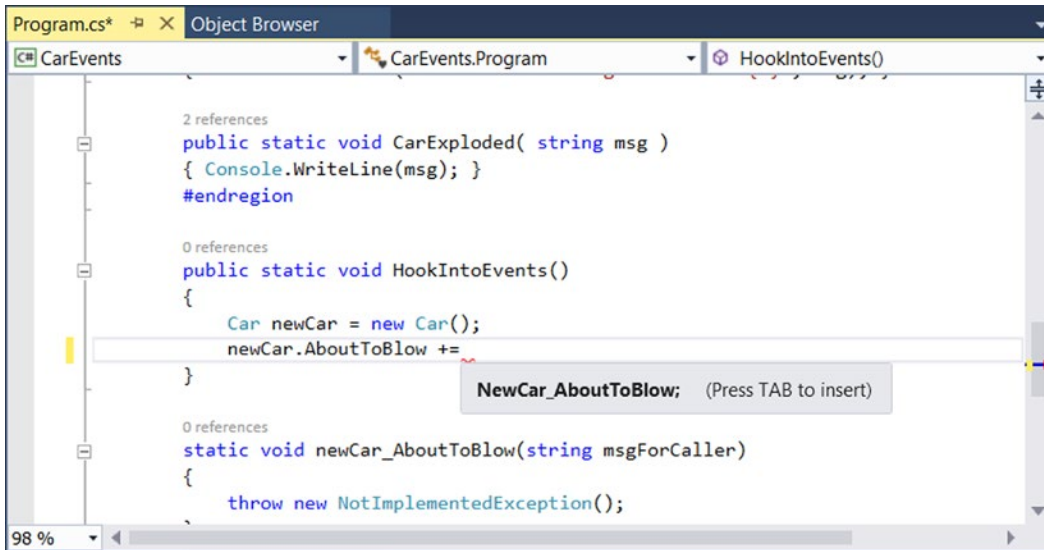

Figure 10-2. Delegate selection IntelliSense

After you hit the Tab key, the IDE will generate the new method automatically, as shown in Figure 10-3.

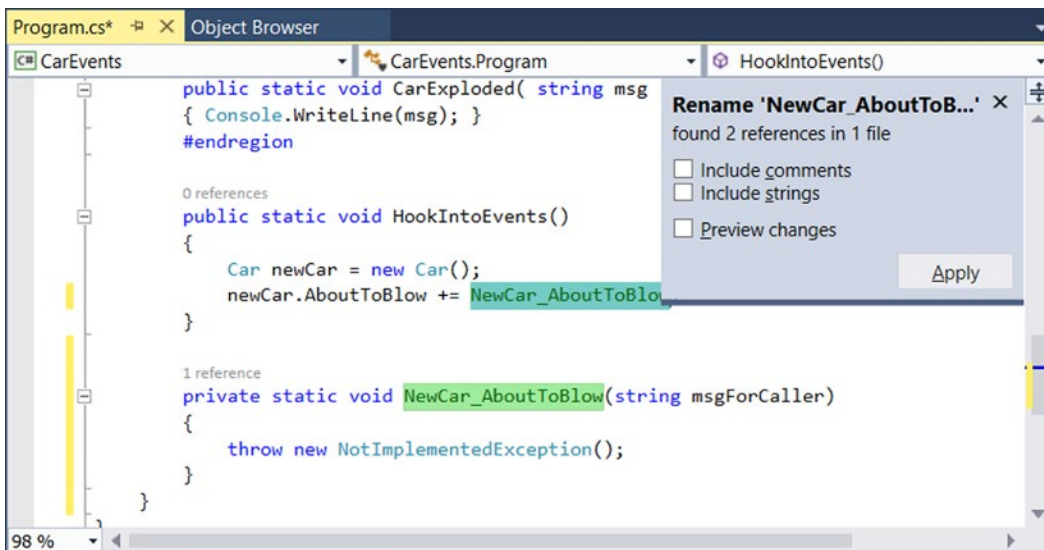

Figure 10-3. Delegate target format IntelliSense

Note the stub code is in the correct format of the delegate target (note that this method has been declared static because the event was registered within a static method).

```
static void NewCar_AboutToBlow(string msg)
{
    // Delete the following line and add your code!
    throw new NotImplementedException();
}
```

IntelliSense is available to all .NET events in the base class libraries. This IDE feature is a massive time-saver, given that it saves you from having to search the .NET help system to figure out both the correct delegate to use with a particular event and the format of the delegate target method.

Cleaning Up Event Invocation Using the C# 6.0 Null-Conditional Operator

In the current example, you most likely noticed that before you fired an event to any listener, you made sure to check for null. This is important given that if nobody is listening for your event but you fire it anyway, you will receive a null reference exception at runtime. While important, you might agree it is a bit clunky to make numerous conditional checks against null.

Thankfully, with the current release of C#, you can leverage the null conditional operator (?) which essentially performs this sort of check automatically. Be aware, when using this new simplified syntax, you must manually call the `Invoke()` method of the underlying delegate. For example, rather than saying this:

```
// If the car is dead, fire Exploded event.
if (carIsDead)
{
    if (Exploded != null)
        Exploded("Sorry, this car is dead...");
}
```

We can now simply say the following:

```
// If the car is dead, fire Exploded event.
if (carIsDead)
{
    Exploded?.Invoke("Sorry, this car is dead...");
}
```

you could also update the code that fires the `AboutToBlow` event in a similar manner (note here I moved the check for null out of the original if statement):

```
// Almost dead?
if (10 == MaxSpeed - CurrentSpeed)
{
    AboutToBlow?.Invoke("Careful buddy! Gonna blow!");
}
```

Because of the simplified syntax, you are likely to favor the null conditional operator when firing events. However, it is still perfectly acceptable to manually check for null when necessary.

■ **Source Code** The CarEvents project is located in the Chapter 10 subdirectory.

Creating Custom Event Arguments

Truth be told, there is one final enhancement you could make to the current iteration of the Car class that mirrors Microsoft's recommended event pattern. As you begin to explore the events sent by a given type in the base class libraries, you will find that the first parameter of the underlying delegate is a `System.Object`, while the second parameter is a descendant of `System.EventArgs`.

The `System.Object` argument represents a reference to the object that sent the event (such as the Car), while the second parameter represents information regarding the event at hand. The `System.EventArgs` base class represents an event that is not sending any custom information.

```
public class EventArgs
{
    public static readonly EventArgs Empty;
    public EventArgs();
}
```

For simple events, you can pass an instance of `EventArgs` directly. However, when you want to pass along custom data, you should build a suitable class deriving from `EventArgs`. For this example, assume you have a class named `CarEventArgs`, which maintains a string representing the message sent to the receiver.

```
public class CarEventArgs : EventArgs
{
    public readonly string msg;
    public CarEventArgs(string message)
    {
        msg = message;
    }
}
```

With this, you would now update the `CarEngineHandler` delegate type definition as follows (the events would be unchanged):

```
public class Car
{
    public delegate void CarEngineHandler(object sender, CarEventArgs e);
    ...
}
```

Here, when firing the events from within the `Accelerate()` method, you would now need to supply a reference to the current `Car` (via the `this` keyword) and an instance of the `CarEventArgs` type. For example, consider the following partial update:

```
public void Accelerate(int delta)
{
    // If the car is dead, fire Exploded event.
    if (carIsDead)
    {
        Exploded?.Invoke(this, new CarEventArgs("Sorry, this car is dead..."));
    }
    ...
}
```

On the caller's side, all you would need to do is update your event handlers to receive the incoming parameters and obtain the message via the read-only field. Here's an example:

```
public static void CarAboutToBlow(object sender, CarEventArgs e)
{
    Console.WriteLine("{0} says: {1}", sender, e.msg);
}
```

If the receiver wants to interact with the object that sent the event, you can explicitly cast the `System.Object`. From this reference, you can make use of any public member of the object that sent the event notification.

```
public static void CarAboutToBlow(object sender, CarEventArgs e)
{
    // Just to be safe, perform a
    // runtime check before casting.
    if (sender is Car)
    {
        Car c = (Car)sender;
        Console.WriteLine("Critical Message from {0}: {1}", c.PetName, e.msg);
    }
}
```

■ **Source Code** The `CarEventArgs` project is located in the Chapter 10 subdirectory.

The Generic EventHandler<T> Delegate

Given that so many custom delegates take an object as the first parameter and an EventArgs descendant as the second, you could further streamline the previous example by using the generic EventHandler<T> type, where T is your custom EventArgs type. Consider the following update to the Car type (notice how you no longer need to define a custom delegate type at all):

```
public class Car
{
    public event EventHandler<CarEventArgs> Exploded;
    public event EventHandler<CarEventArgs> AboutToBlow;
    ...
}
```

The Main() method could then use EventHandler<CarEventArgs> anywhere you previously specified CarEventHandler (or, once again, use method group conversion).

```
static void Main(string[] args)
{
    Console.WriteLine("***** Prim and Proper Events *****\n");

    // Make a car as usual.
    Car c1 = new Car("SlugBug", 100, 10);

    // Register event handlers.
    c1.AboutToBlow += CarIsAlmostDoomed;
    c1.AboutToBlow += CarAboutToBlow;

    EventHandler<CarEventArgs> d = new EventHandler<CarEventArgs>(CarExploded);
    c1.Exploded += d;
    ...
}
```

Great! At this point, you have seen the core aspects of working with delegates and events in the C# language. While you could use this information for just about all your callback needs, you will wrap up this chapter with a look at some final simplifications, specifically anonymous methods and lambda expressions.

■ **Source Code** The GenericCarEventArgs project is located in the Chapter 10 subdirectory.

Understanding C# Anonymous Methods

As you have seen, when a caller wants to listen to incoming events, it must define a custom method in a class (or structure) that matches the signature of the associated delegate. Here's an example:

```
class Program
{
    static void Main(string[] args)
    {
        SomeType t = new SomeType();

        // Assume "SomeDelegate" can point to methods taking no
        // args and returning void.
        t.SomeEvent += new SomeDelegate(MyEventHandler);
    }

    // Typically only called by the SomeDelegate object.
    public static void MyEventHandler()
    {
        // Do something when event is fired.
    }
}
```

When you think about it, however, methods such as `MyEventHandler()` are seldom intended to be called by any part of the program other than the invoking delegate. As far as productivity is concerned, it is a bit of a bother (though in no way a showstopper) to manually define a separate method to be called by the delegate object.

To address this point, it is possible to associate an event directly to a block of code statements at the time of event registration. Formally, such code is termed an *anonymous method*. To illustrate the syntax, check out the following `Main()` method, which handles the events sent from the `Car` class using anonymous methods, rather than specifically named event handlers:

```
class Program
{
    static void Main(string[] args)
    {
        Console.WriteLine("***** Anonymous Methods *****\n");
        Car c1 = new Car("SlugBug", 100, 10);

        // Register event handlers as anonymous methods.
        c1.AboutToBlow += delegate
        {
            Console.WriteLine("Eek! Going too fast!");
        };

        c1.AboutToBlow += delegate(object sender, CarEventArgs e)
        {
            Console.WriteLine("Message from Car: {0}", e.msg);
        };
    }
}
```

```

    c1.Exploded += delegate(object sender, CarEventArgs e)
    {
        Console.WriteLine("Fatal Message from Car: {0}", e.msg);
    };

    // This will eventually trigger the events.
    for (int i = 0; i < 6; i++)
        c1.Accelerate(20);

    Console.ReadLine();
}
}

```

■ **Note** The final curly bracket of an anonymous method must be terminated by a semicolon. If you fail to do so, you are issued a compilation error.

Again, notice that the `Program` type no longer defines specific static event handlers such as `CarAboutToBlow()` or `CarExploded()`. Rather, the unnamed (aka anonymous) methods are defined inline at the time the caller is handling the event using the `+=` syntax. The basic syntax of an anonymous method matches the following pseudocode:

```

class Program
{
    static void Main(string[] args)
    {
        SomeType t = new SomeType();
        t.SomeEvent += delegate (optionallySpecifiedDelegateArgs)
        { /* statements */ };
    }
}

```

When handling the first `AboutToBlow` event within the previous `Main()` method, notice that you are not specifying the arguments passed from the delegate.

```

c1.AboutToBlow += delegate
{
    Console.WriteLine("Eek! Going too fast!");
};

```

Strictly speaking, you are not required to receive the incoming arguments sent by a specific event. However, if you want to make use of the possible incoming arguments, you will need to specify the parameters prototyped by the delegate type (as shown in the second handling of the `AboutToBlow` and `Exploded` events). Here's an example:

```

c1.AboutToBlow += delegate(object sender, CarEventArgs e)
{
    Console.WriteLine("Critical Message from Car: {0}", e.msg);
};

```

Accessing Local Variables

Anonymous methods are interesting in that they are able to access the local variables of the method that defines them. Formally speaking, such variables are termed *outer variables* of the anonymous method. A few important points about the interaction between an anonymous method scope and the scope of the defining method should be mentioned.

- An anonymous method cannot access `ref` or `out` parameters of the defining method.
- An anonymous method cannot have a local variable with the same name as a local variable in the outer method.
- An anonymous method can access instance variables (or static variables, as appropriate) in the outer class scope.
- An anonymous method can declare local variables with the same name as outer class member variables (the local variables have a distinct scope and hide the outer class member variables).

Assume your `Main()` method defined a local integer named `aboutToBlowCounter`. Within the anonymous methods that handle the `AboutToBlow` event, you will increment this counter by one and print out the tally before `Main()` completes.

```
static void Main(string[] args)
{
    Console.WriteLine("***** Anonymous Methods *****\n");
    int aboutToBlowCounter = 0;

    // Make a car as usual.
    Car c1 = new Car("SlugBug", 100, 10);

    // Register event handlers as anonymous methods.
    c1.AboutToBlow += delegate
    {
        aboutToBlowCounter++;
        Console.WriteLine("Eek! Going too fast!");
    };

    c1.AboutToBlow += delegate(object sender, CarEventArgs e)
    {
        aboutToBlowCounter++;
        Console.WriteLine("Critical Message from Car: {0}", e.msg);
    };

    // This will eventually trigger the events.
    for (int i = 0; i < 6; i++)
        c1.Accelerate(20);

    Console.WriteLine("AboutToBlow event was fired {0} times.",
        aboutToBlowCounter);
    Console.ReadLine();
}
```

After you run this updated `Main()` method, you will find the final `Console.WriteLine()` reports the `AboutToBlow` event was fired twice.

■ **Source Code** The `AnonymousMethods` project is located in the [Chapter 10](#) subdirectory.

Understanding Lambda Expressions

To conclude your look at the .NET event architecture, you will examine C# *lambda expressions*. As just explained, C# supports the ability to handle events “inline” by assigning a block of code statements directly to an event using anonymous methods, rather than building a stand-alone method to be called by the underlying delegate. Lambda expressions are nothing more than a concise way to author anonymous methods and ultimately simplify how you work with the .NET delegate type.

To set the stage for your examination of lambda expressions, create a new Console Application project named `SimpleLambdaExpressions`. To begin, consider the `FindAll()` method of the generic `List<T>` class. This method can be called when you need to extract a subset of items from the collection and is prototyped like so:

```
// Method of the System.Collections.Generic.List<T> class.
public List<T> FindAll(Predicate<T> match)
```

As you can see, this method returns a new `List<T>` that represents the subset of data. Also notice that the sole parameter to `FindAll()` is a generic delegate of type `System.Predicate<T>`. This delegate type can point to any method returning a `bool` and takes a single type parameter as the only input parameter.

```
// This delegate is used by FindAll() method
// to extract out the subset.
public delegate bool Predicate<T>(T obj);
```

When you call `FindAll()`, each item in the `List<T>` is passed to the method pointed to by the `Predicate<T>` object. The implementation of said method will perform some calculations to see whether the incoming data matches the necessary criteria and will return `true` or `false`. If this method returns `true`, the item will be added to the new `List<T>` that represents the subset (got all that?).

Before you see how lambda expressions can simplify working with `FindAll()`, let’s work the problem out in longhand notation, using the delegate objects directly. Add a method (named `TraditionalDelegateSyntax()`) within your `Program` type that interacts with the `System.Predicate<T>` type to discover the even numbers in a `List<T>` of integers.

```
class Program
{
    static void Main(string[] args)
    {
        Console.WriteLine("***** Fun with Lambdas *****\n");
        TraditionalDelegateSyntax();
        Console.ReadLine();
    }
}
```

```

static void TraditionalDelegateSyntax()
{
    // Make a list of integers.
    List<int> list = new List<int>();
    list.AddRange(new int[] { 20, 1, 4, 8, 9, 44 });

    // Call FindAll() using traditional delegate syntax.
    Predicate<int> callback = IsEvenNumber;
    List<int> evenNumbers = list.FindAll(callback);

    Console.WriteLine("Here are your even numbers:");
    foreach (int evenNumber in evenNumbers)
    {
        Console.Write("{0}\t", evenNumber);
    }
    Console.WriteLine();
}

// Target for the Predicate<> delegate.
static bool IsEvenNumber(int i)
{
    // Is it an even number?
    return (i % 2) == 0;
}
}

```

Here, you have a method (`IsEvenNumber()`) that is in charge of testing the incoming integer parameter to see whether it is even or odd via the C# modulo operator, `%`. If you execute your application, you will find the numbers 20, 4, 8, and 44 print to the console.

While this traditional approach to working with delegates behaves as expected, the `IsEvenNumber()` method is invoked only in limited circumstances—specifically when you call `FindAll()`, which leaves you with the baggage of a full method definition. If you were to instead use an anonymous method, your code would clean up considerably. Consider the following new method of the `Program` class:

```

static void AnonymousMethodSyntax()
{
    // Make a list of integers.
    List<int> list = new List<int>();
    list.AddRange(new int[] { 20, 1, 4, 8, 9, 44 });

    // Now, use an anonymous method.
    List<int> evenNumbers = list.FindAll(delegate(int i)
        { return (i % 2) == 0; });

    Console.WriteLine("Here are your even numbers:");
    foreach (int evenNumber in evenNumbers)
    {
        Console.Write("{0}\t", evenNumber);
    }
    Console.WriteLine();
}

```

In this case, rather than directly creating a `Predicate<T>` delegate object and then authoring a stand-alone method, you are able to inline a method anonymously. While this is a step in the right direction, you are still required to use the `delegate` keyword (or a strongly typed `Predicate<T>`), and you must ensure that the parameter list is a dead-on match.

```
List<int> evenNumbers = list.FindAll(
    delegate(int i)
    {
        return (i % 2) == 0;
    }
);
```

Lambda expressions can be used to simplify the call to `FindAll()` even more. When you use lambda syntax, there is no trace of the underlying delegate object whatsoever. Consider the following new method to the `Program` class:

```
static void LambdaExpressionSyntax()
{
    // Make a list of integers.
    List<int> list = new List<int>();
    list.AddRange(new int[] { 20, 1, 4, 8, 9, 44 });

    // Now, use a C# lambda expression.
    List<int> evenNumbers = list.FindAll(i => (i % 2) == 0);

    Console.WriteLine("Here are your even numbers:");
    foreach (int evenNumber in evenNumbers)
    {
        Console.WriteLine("{0}\t", evenNumber);
    }
    Console.WriteLine();
}
```

In this case, notice the rather strange statement of code passed into the `FindAll()` method, which is in fact a lambda expression. In this iteration of the example, there is no trace whatsoever of the `Predicate<T>` delegate (or the `delegate` keyword, for that matter). All you have specified is the lambda expression.

```
i => (i % 2) == 0
```

Before I break this syntax down, first understand that lambda expressions can be used anywhere you would have used an anonymous method or a strongly typed delegate (typically with far fewer keystrokes). Under the hood, the C# compiler translates the expression into a standard anonymous method making use of the `Predicate<T>` delegate type (which can be verified using `ildasm.exe` or `reflector.exe`). Specifically, the following code statement:

```
// This lambda expression...
List<int> evenNumbers = list.FindAll(i => (i % 2) == 0);
```

is compiled into the following approximate C# code:

```
// ...becomes this anonymous method.
List<int> evenNumbers = list.FindAll(delegate (int i)
{
    return (i % 2) == 0;
});
```

Dissecting a Lambda Expression

A lambda expression is written by first defining a parameter list, followed by the => token (C#'s token for the lambda operator found in the *lambda calculus*), followed by a set of statements (or a single statement) that will process these arguments. From a high level, a lambda expression can be understood as follows:

ArgumentsToProcess => StatementsToProcessThem

Within the `LambdaExpressionSyntax()` method, things break down like so:

```
// "i" is our parameter list.
// "(i % 2) == 0" is our statement set to process "i".
List<int> evenNumbers = list.FindAll(i => (i % 2) == 0);
```

The parameters of a lambda expression can be explicitly or implicitly typed. Currently, the underlying data type representing the `i` parameter (an integer) is determined implicitly. The compiler is able to figure out that `i` is an integer based on the context of the overall lambda expression and the underlying delegate. However, it is also possible to explicitly define the type of each parameter in the expression, by wrapping the data type and variable name in a pair of parentheses, as follows:

```
// Now, explicitly state the parameter type.
List<int> evenNumbers = list.FindAll((int i) => (i % 2) == 0);
```

As you have seen, if a lambda expression has a single, implicitly typed parameter, the parentheses may be omitted from the parameter list. If you want to be consistent regarding your use of lambda parameters, you can *always* wrap the parameter list within parentheses, leaving you with this expression:

```
List<int> evenNumbers = list.FindAll((i) => (i % 2) == 0);
```

Finally, notice that currently the expression has not been wrapped in parentheses (you have of course wrapped the modulo statement to ensure it is executed first before the test for equality). Lambda expressions do allow for the statement to be wrapped as follows:

```
// Now, wrap the expression as well.
List<int> evenNumbers = list.FindAll((i) => ((i % 2) == 0));
```

Now that you have seen the various ways to build a lambda expression, how can you read this lambda statement in human-friendly terms? Leaving the raw mathematics behind, the following explanation fits the bill:

```
// My list of parameters (in this case, a single integer named i)
// will be processed by the expression (i % 2) == 0.
List<int> evenNumbers = list.FindAll((i) => ((i % 2) == 0));
```

Processing Arguments Within Multiple Statements

The first lambda expression was a single statement that ultimately evaluated to a Boolean. However, as you know, many delegate targets must perform a number of code statements. For this reason, C# allows you to build lambda expressions using multiple statement blocks. When your expression must process the parameters using multiple lines of code, you can do so by denoting a scope for these statements using the expected curly brackets. Consider the following example update to the `LambdaExpressionSyntax()` method:

```
static void LambdaExpressionSyntax()
{
    // Make a list of integers.
    List<int> list = new List<int>();
    list.AddRange(new int[] { 20, 1, 4, 8, 9, 44 });

    // Now process each argument within a group of
    // code statements.
    List<int> evenNumbers = list.FindAll((i) =>
    {
        Console.WriteLine("value of i is currently: {0}", i);
        bool isEven = ((i % 2) == 0);
        return isEven;
    });

    Console.WriteLine("Here are your even numbers:");
    foreach (int evenNumber in evenNumbers)
    {
        Console.WriteLine("{0}\t", evenNumber);
    }
    Console.WriteLine();
}
```

In this case, the parameter `list` (again, a single integer named `i`) is being processed by a set of code statements. Beyond the calls to `Console.WriteLine()`, the modulo statement has been broken into two code statements for increased readability. Assuming each of the methods you've looked at in this section are called from within `Main()`:

```
static void Main(string[] args)
{
    Console.WriteLine("***** Fun with Lambdas *****\n");
    TraditionalDelegateSyntax();
    AnonymousMethodSyntax();
    Console.WriteLine();
    LambdaExpressionSyntax();
    Console.ReadLine();
}
```

you will find the following output:

```

***** Fun with Lambdas *****
Here are your even numbers:
20    4    8    44
Here are your even numbers:
20    4    8    44
value of i is currently: 20
value of i is currently: 1
value of i is currently: 4
value of i is currently: 8
value of i is currently: 9
value of i is currently: 44
Here are your even numbers:
20    4    8    44

```

■ **Source Code** The SimpleLambdaExpressions project can be found in the [Chapter 10](#) subdirectory.

Lambda Expressions with Multiple (or Zero) Parameters

The lambda expressions you have seen here processed a single parameter. This is not a requirement, however, as a lambda expression may process multiple arguments (or none). To illustrate the first scenario, create a Console Application project named LambdaExpressionsMultipleParams. Next, assume the following incarnation of the SimpleMath type:

```

public class SimpleMath
{
    public delegate void MathMessage(string msg, int result);
    private MathMessage mmDelegate;

    public void SetMathHandler(MathMessage target)
    {mmDelegate = target; }

    public void Add(int x, int y)
    {
        mmDelegate?.Invoke("Adding has completed!", x + y);
    }
}

```

Notice that the `MathMessage` delegate type is expecting two parameters. To represent them as a lambda expression, the `Main()` method might be written as follows:

```
static void Main(string[] args)
{
    // Register with delegate as a lambda expression.
    SimpleMath m = new SimpleMath();
    m.SetMathHandler((msg, result) =>
        {Console.WriteLine("Message: {0}, Result: {1}", msg, result)});

    // This will execute the lambda expression.
    m.Add(10, 10);
    Console.ReadLine();
}
```

Here, you are leveraging type inference, as the two parameters have not been strongly typed for simplicity. However, you could call `SetMathHandler()`, as follows:

```
m.SetMathHandler((string msg, int result) =>
    {Console.WriteLine("Message: {0}, Result: {1}", msg, result)});
```

Finally, if you are using a lambda expression to interact with a delegate taking no parameters at all, you may do so by supplying a pair of empty parentheses as the parameter. Thus, assuming you have defined the following delegate type:

```
public delegate string VerySimpleDelegate();
```

you could handle the result of the invocation as follows:

```
// Prints "Enjoy your string!" to the console.
VerySimpleDelegate d = new VerySimpleDelegate( () => {return "Enjoy your string!";} );
Console.WriteLine(d());
```

■ **Source Code** The `LambdaExpressionsMultipleParams` project can be found in the [Chapter 10](#) subdirectory.

Retrofitting the CarEvents Example Using Lambda Expressions

Given that the whole reason for lambda expressions is to provide a clean, concise manner to define an anonymous method (and therefore indirectly a manner to simplify working with delegates), let's retrofit the CarEventArgs project created earlier in this chapter. Here is a simplified version of that project's Program class, which makes use of lambda expression syntax (rather than the raw delegates) to hook into each event sent from the Car object:

```
static void Main(string[] args)
{
    Console.WriteLine("***** More Fun with Lambdas *****\n");

    // Make a car as usual.
    Car c1 = new Car("SlugBug", 100, 10);

    // Hook into events with lambdas!
    c1.AboutToBlow += (sender, e) => { Console.WriteLine(e.msg);};
    c1.Exploded += (sender, e) => { Console.WriteLine(e.msg); };

    // Speed up (this will generate the events).
    Console.WriteLine("\n***** Speeding up *****");
    for (int i = 0; i < 6; i++)
        c1.Accelerate(20);

    Console.ReadLine();
}
```

Lambdas and Single Statement Member Implementations

The final point to be made about the C# lambda operator is that, as of .NET 4.6, it is now permissible to use the => operator to simplify some (but not all) member implementations. Specifically, if you have a method or property (in addition to a custom operator or conversion routine; see Chapter 11) that consists of exactly a single line of code in the implementation, you are not required to define a scope via curly bracket. You can instead leverage the lambda operator.

Consider the previous code example where you wired in code to handle the AboutToBlow and Exploded events. Note how you defined a curly-bracket scope to capture the Console.WriteLine() method calls. If you like, you could now simply write the following:

```
c1.AboutToBlow += (sender, e) => Console.WriteLine(e.msg);
c1.Exploded += (sender, e) => Console.WriteLine(e.msg);
```

Be aware, however, this new shortened syntax can be use anywhere at all, even when your code has nothing to do with delegates or events. So for example, if you were to build a trivial class to add two numbers, you might write the following:

```
class SimpleMath
{
    public int Add(int x, int y)
    {
        return x + y;
    }

    public void PrintSum(int x, int y)
    {
        Console.WriteLine(x + y);
    }
}
```

Alternatively, you could now write code like the following:

```
class SimpleMath
{
    public int Add(int x, int y) => x + y;
    public void PrintSum(int x, int y) => Console.WriteLine(x + y);
}
```

Ideally, at this point you can see the overall role of lambda expressions and understand how they provide a “functional manner” to work with anonymous methods and delegate types. Although the lambda operator (`=>`) might take a bit to get used to, always remember a lambda expression can be broken down to the following simple equation:

ArgumentsToProcess => StatementsToProcessThem

Or, if using the `=>` operator to implement a single line type member, it would be like this:

TypeMember => SingleCodeStatement

It is worth pointing out that the LINQ programming model also makes substantial use of lambda expressions to help simplify your coding efforts. You will examine LINQ beginning in Chapter 12.

■ **Source Code** The CarEventsWithLambdas project can be found in the Chapter 10 subdirectory.

Summary

In this chapter, you examined a number of ways in which multiple objects can partake in a bidirectional conversation. First, you looked at the C# `delegate` keyword, which is used to indirectly construct a class derived from `System.MulticastDelegate`. As you saw, a delegate object maintains a list of methods to call when told to do so. These invocations may be made synchronously (using the `Invoke()` method) or asynchronously (via the `BeginInvoke()` and `EndInvoke()` methods). Again, the asynchronous nature of .NET delegate types will be examined in Chapter 19.

You then examined the C# `event` keyword, which, when used in conjunction with a delegate type, can simplify the process of sending your event notifications to waiting callers. As shown via the resulting CIL, the .NET event model maps to hidden calls on the `System.Delegate/System.MulticastDelegate` types. In this light, the C# `event` keyword is purely optional in that it simply saves you some typing time. As well, you have seen that the C# 6.0 null conditional operator simplifies how you safely fire events to any interested party.

This chapter also explored a C# language feature termed *anonymous methods*. Using this syntactic construct, you are able to directly associate a block of code statements to a given event. As you have seen, anonymous methods are free to ignore the parameters sent by the event and have access to the “outer variables” of the defining method. You also examined a simplified way to register events using *method group conversion*.

Finally, you wrapped things up by looking at the C# *lambda operator*, `=>`. As shown, this syntax is a great shorthand notation for authoring anonymous methods, where a stack of arguments can be passed into a group of statements for processing. Any method in the .NET platform that takes a delegate object as an argument can be substituted with a related lambda expression, which will typically simplify your code base quite a bit.

CHAPTER 11



Advanced C# Language Features

In this chapter, you'll deepen your understanding of the C# programming language by examining a number of more advanced topics. To begin, you'll learn how to implement and use an *indexer method*. This C# mechanism enables you to build custom types that provide access to internal subitems using an array-like syntax. After you learn how to build an indexer method, you'll see how to overload various operators (+, -, <, >, and so forth) and how to create custom explicit and implicit conversion routines for your types (and you'll learn why you might want to do this).

Next, you'll examine topics that are particularly useful when working with LINQ-centric APIs (though you can use them outside of the context of LINQ)—specifically extension methods and anonymous types.

To wrap things up, you'll learn how to create an “unsafe” code context to directly manipulate unmanaged pointers. While it is certainly true that using pointers in C# applications is a fairly infrequent activity, understanding how to do so can be helpful in some circumstances that involve complex interoperability scenarios.

Understanding Indexer Methods

As a programmer, you are certainly familiar with the process of accessing individual items contained within a simple array using the index operator ([]). Here's an example:

```
static void Main(string[] args)
{
    // Loop over incoming command-line arguments
    // using index operator.
    for(int i = 0; i < args.Length; i++)
        Console.WriteLine("Args: {0}", args[i]);

    // Declare an array of local integers.
    int[] myInts = { 10, 9, 100, 432, 9874};

    // Use the index operator to access each element.
    for(int j = 0; j < myInts.Length; j++)
        Console.WriteLine("Index {0} = {1} ", j, myInts[j]);
    Console.ReadLine();
}
```

This code is by no means a major news flash. However, the C# language provides the capability to design custom classes and structures that may be indexed just like a standard array, by defining an *indexer method*. This particular feature is most useful when you are creating custom collection classes (generic or nongeneric).

Before examining how to implement a custom indexer, let's begin by seeing one in action. Assume you have added support for an indexer method to the custom `PersonCollection` type developed in Chapter 9 (specifically, the `IssuesWithNonGenericCollections` project). While you have not yet added the indexer, observe the following usage within a new Console Application project named `SimpleIndexer`:

```
// Indexers allow you to access items in an array-like fashion.
class Program
{
    static void Main(string[] args)
    {
        Console.WriteLine("***** Fun with Indexers *****\n");

        PersonCollection myPeople = new PersonCollection();

        // Add objects with indexer syntax.
        myPeople[0] = new Person("Homer", "Simpson", 40);
        myPeople[1] = new Person("Marge", "Simpson", 38);
        myPeople[2] = new Person("Lisa", "Simpson", 9);
        myPeople[3] = new Person("Bart", "Simpson", 7);
        myPeople[4] = new Person("Maggie", "Simpson", 2);

        // Now obtain and display each item using indexer.
        for (int i = 0; i < myPeople.Count; i++)
        {
            Console.WriteLine("Person number: {0}", i);
            Console.WriteLine("Name: {0} {1}",
                myPeople[i].FirstName, myPeople[i].LastName);
            Console.WriteLine("Age: {0}", myPeople[i].Age);
            Console.WriteLine();
        }
    }
}
```

As you can see, indexers allow you to manipulate the internal collection of subobjects just like a standard array. Now for the big question: how do you configure the `PersonCollection` class (or any custom class or structure) to support this functionality? An indexer is represented as a slightly modified C# property definition. In its simplest form, an indexer is created using the `this[]` syntax. Here is the required update for the `PersonCollection` class:

```
// Add the indexer to the existing class definition.
public class PersonCollection : IEnumerable
{
    private ArrayList arPeople = new ArrayList();

    // Custom indexer for this class.
    public Person this[int index]
    {
        get { return (Person)arPeople[index]; }
        set { arPeople.Insert(index, value); }
    }
    ...
}
```

Apart from using the `this` keyword, the indexer looks just like any other C# property declaration. For example, the role of the `get` scope is to return the correct object to the caller. Here, you are doing so by delegating the request to the indexer of the `ArrayList` object, as this class also supports an indexer. The `set` scope is in charge of adding new `Person` objects; this is achieved by calling the `Insert()` method of the `ArrayList`.

Indexers are yet another form of syntactic sugar, given that this functionality can also be achieved using “normal” public methods such as `AddPerson()` or `GetPerson()`. Nevertheless, when you support indexer methods on your custom collection types, they integrate well into the fabric of the .NET base class libraries.

While creating indexer methods is quite commonplace when you are building custom collections, do remember that generic types give you this functionality out of the box. Consider the following method, which uses a generic `List<T>` of `Person` objects. Note that you can simply use the indexer of `List<T>` directly. Here’s an example:

```
static void UseGenericListOfPeople()
{
    List<Person> myPeople = new List<Person>();
    myPeople.Add(new Person("Lisa", "Simpson", 9));
    myPeople.Add(new Person("Bart", "Simpson", 7));

    // Change first person with indexer.
    myPeople[0] = new Person("Maggie", "Simpson", 2);

    // Now obtain and display each item using indexer.
    for (int i = 0; i < myPeople.Count; i++)
    {
        Console.WriteLine("Person number: {0}", i);
        Console.WriteLine("Name: {0} {1}", myPeople[i].FirstName,
            myPeople[i].LastName);
        Console.WriteLine("Age: {0}", myPeople[i].Age);
        Console.WriteLine();
    }
}
```

■ **Source Code** The `SimpleIndexer` project is located in the [Chapter 11](#) subdirectory.

Indexing Data Using String Values

The current `PersonCollection` class defined an indexer that allowed the caller to identify subitems using a numerical value. Understand, however, that this is not a requirement of an indexer method. Suppose you’d prefer to contain the `Person` objects using a `System.Collections.Generic.Dictionary<TKey, TValue>` rather than an `ArrayList`. Given that `Dictionary` types allow access to the contained types using a key (such as a person’s first name), you could define an indexer as follows:

```
public class PersonCollection : IEnumerable
{
    private Dictionary<string, Person> listPeople =
        new Dictionary<string, Person>();
```

```

// This indexer returns a person based on a string index.
public Person this[string name]
{
    get { return (Person)listPeople[name]; }
    set { listPeople[name] = value; }
}
public void ClearPeople()
{ listPeople.Clear(); }

public int Count
{ get { return listPeople.Count; } }

IEnumerator IEnumerable.GetEnumerator()
{ return listPeople.GetEnumerator(); }
}

```

The caller would now be able to interact with the contained `Person` objects as shown here:

```

static void Main(string[] args)
{
    Console.WriteLine("***** Fun with Indexers *****\n");

    PersonCollection myPeople = new PersonCollection();

    myPeople["Homer"] = new Person("Homer", "Simpson", 40);
    myPeople["Marge"] = new Person("Marge", "Simpson", 38);

    // Get "Homer" and print data.
    Person homer = myPeople["Homer"];
    Console.WriteLine(homer.ToString());

    Console.ReadLine();
}

```

Again, if you were to use the generic `Dictionary<TKey, TValue>` type directly, you'd gain the indexer method functionality out of the box, without building a custom, nongeneric class supporting a string indexer. Nevertheless, do understand that the data type of any indexer will be based on how the supporting collection type allows the caller to retrieve subitems.

■ **Source Code** The `StringIndexer` project is located under the [Chapter 11](#) subdirectory.

Overloading Indexer Methods

Understand that indexer methods may be overloaded on a single class or structure. Thus, if it makes sense to allow the caller to access subitems using a numerical index *or* a string value, you might define multiple indexers for a single type. By way of example, in ADO.NET (.NET's native database-access API), the `DataSet` class supports a property named `Tables`, which returns to you a strongly typed `DataTableCollection` type.

As it turns out, `DataTableCollection` defines *three* indexers to get and set `DataTable` objects—one by ordinal position and the others by a friendly string moniker and optional containing namespace, as shown here:

```
public sealed class DataTableCollection : InternalDataCollectionBase
{
    ...
    // Overloaded indexers!
    public DataTable this[int index] { get; }
    public DataTable this[string name] { get; }
    public DataTable this[string name, string tableName] { get; }
}
```

It is common for types in the base class libraries to support indexer methods. So be aware, even if your current project does not require you to build custom indexers for your classes and structures, that many types already support this syntax.

Indexers with Multiple Dimensions

You can also create an indexer method that takes multiple parameters. Assume you have a custom collection that stores subitems in a 2D array. If this is the case, you may define an indexer method as follows:

```
public class SomeContainer
{
    private int[,] my2DintArray = new int[10, 10];

    public int this[int row, int column]
    { /* get or set value from 2D array */ }
}
```

Again, unless you are building a highly stylized custom collection class, you won't have much need to build a multidimensional indexer. Still, once again ADO.NET showcases how useful this construct can be. The ADO.NET `DataTable` is essentially a collection of rows and columns, much like a piece of graph paper or the general structure of a Microsoft Excel spreadsheet.

While `DataTable` objects are typically populated on your behalf using a related “data adapter,” the following code illustrates how to manually create an in-memory `DataTable` containing three columns (for the first name, last name, and age of each record). Notice how once you have added a single row to the `DataTable`, you use a multidimensional indexer to drill into each column of the first (and only) row. (If you are following along, you'll need to import the `System.Data` namespace into your code file.)

```
static void MultiIndexerWithDataTable()
{
    // Make a simple DataTable with 3 columns.
    DataTable myTable = new DataTable();
    myTable.Columns.Add(new DataColumn("FirstName"));
    myTable.Columns.Add(new DataColumn("LastName"));
    myTable.Columns.Add(new DataColumn("Age"));

    // Now add a row to the table.
    myTable.Rows.Add("Mel", "Appleby", 60);
}
```

```
// Use multidimension indexer to get details of first row.
Console.WriteLine("First Name: {0}", myTable.Rows[0][0]);
Console.WriteLine("Last Name: {0}", myTable.Rows[0][1]);
Console.WriteLine("Age : {0}", myTable.Rows[0][2]);
}
```

Do be aware that you'll take a rather deep dive into ADO.NET beginning with Chapter 21, so if some of the previous code seems unfamiliar, fear not. The main point of this example is that indexer methods can support multiple dimensions and, if used correctly, can simplify the way you interact with contained subobjects in custom collections.

Indexer Definitions on Interface Types

Indexers can be defined on a given .NET interface type to allow supporting types to provide a custom implementation. Here is a simple example of an interface that defines a protocol for obtaining string objects using a numerical indexer:

```
public interface IStringContainer
{
    string this[int index] { get; set; }
}
```

With this interface definition, any class or structure that implements this interface must now support a read-write indexer that manipulates subitems using a numerical value. Here is a partial implementation of such as class:

```
class SomeClass : IStringContainer
{
    private List<string> myStrings = new List<string>();

    public string this[int index]
    {
        get { return myStrings[index]; }
        set { myStrings.Insert(index, value); }
    }
}
```

That wraps up the first major topic of this chapter. Now let's examine a language feature that lets you build custom classes or structures that respond uniquely to the intrinsic operators of C#. Next, allow me to introduce the concept of *operator overloading*.

Understanding Operator Overloading

C#, like any programming language, has a canned set of tokens that are used to perform basic operations on intrinsic types. For example, you know that the + operator can be applied to two integers to yield a larger integer.

```
// The + operator with ints.
int a = 100;
int b = 240;
int c = a + b; // c is now 340
```

Once again, this is no major news flash, but have you ever stopped and noticed how the same + operator can be applied to most intrinsic C# data types? For example, consider this code:

```
// + operator with strings.
string s1 = "Hello";
string s2 = " world!";
string s3 = s1 + s2; // s3 is now "Hello world!"
```

In essence, the + operator functions in specific ways based on the supplied data types (strings or integers, in this case). When the + operator is applied to numerical types, the result is the summation of the operands. However, when the + operator is applied to string types, the result is string concatenation.

The C# language gives you the capability to build custom classes and structures that also respond uniquely to the same set of basic tokens (such as the + operator). While not every possible C# operator can be overloaded, many can, as shown in Table 11-1.

Table 11-1. *Overloadability of C# Operators*

| C# Operator | Overloadability |
|---|---|
| + , - , ! , ~ , ++ , -- , true , false | These unary operators can be overloaded. |
| + , - , * , / , % , & , , ^ , << , >> | These binary operators can be overloaded. |
| == , != , < , > , <= , >= | These comparison operators can be overloaded. C# demands that “like” operators (i.e., < and > , <= and >= , == and !=) are overloaded together. |
| [] | The [] operator cannot be overloaded. As you saw earlier in this chapter, however, the indexer construct provides the same functionality. |
| () | The () operator cannot be overloaded. As you will see later in this chapter, however, custom conversion methods provide the same functionality. |
| + = , - = , * = , / = , % = , & = , = , ^ = , << = , >> = | Shorthand assignment operators cannot be overloaded; however, you receive them as a freebie when you overload the related binary operator. |

Overloading Binary Operators

To illustrate the process of overloading binary operators, assume the following simple Point class is defined in a new Console Application project named OverloadedOps:

```
// Just a simple, everyday C# class.
public class Point
{
    public int X {get; set;}
    public int Y {get; set;}

    public Point(int xPos, int yPos)
    {
        X = xPos;
        Y = yPos;
    }
}
```

```

public override string ToString()
{
    return string.Format("[{0}, {1}]", this.X, this.Y);
}
}

```

Now, logically speaking, it makes sense to “add” Points together. For example, if you added together two Point variables, you should receive a new Point that is the summation of the X and Y values. Of course, it might also be helpful to subtract one Point from another. Ideally, you would like to be able to author the following code:

```

// Adding and subtracting two points?
static void Main(string[] args)
{
    Console.WriteLine("***** Fun with Overloaded Operators *****\n");

    // Make two points.
    Point ptOne = new Point(100, 100);
    Point ptTwo = new Point(40, 40);
    Console.WriteLine("ptOne = {0}", ptOne);
    Console.WriteLine("ptTwo = {0}", ptTwo);

    // Add the points to make a bigger point?
    Console.WriteLine("ptOne + ptTwo: {0} ", ptOne + ptTwo);

    // Subtract the points to make a smaller point?
    Console.WriteLine("ptOne - ptTwo: {0} ", ptOne - ptTwo);
    Console.ReadLine();
}

```

However, as your Point now stands, you will receive compile-time errors, as the Point type does not know how to respond to the + or - operators. To equip a custom type to respond uniquely to intrinsic operators, C# provides the operator keyword, which you can use only in conjunction with the static keyword. When you overload a binary operator (such as + and -), you will most often pass in two arguments that are the same type as the defining class (a Point in this example), as illustrated in the following code update:

```

// A more intelligent Point type.
public class Point
{
    ...
    // Overloaded operator +.
    public static Point operator + (Point p1, Point p2)
    {
        return new Point(p1.X + p2.X, p1.Y + p2.Y);
    }

    // Overloaded operator -.
    public static Point operator - (Point p1, Point p2)
    {
        return new Point(p1.X - p2.X, p1.Y - p2.Y);
    }
}

```

The logic behind operator + is simply to return a new Point object based on the summation of the fields of the incoming Point parameters. Thus, when you write `pt1 + pt2`, under the hood you can envision the following hidden call to the static operator + method.

```
// Pseudo-code: Point p3 = Point.operator+ (p1, p2)
Point p3 = p1 + p2;
```

Likewise, `p1 - p2` maps to the following:

```
// Pseudo-code: Point p4 = Point.operator- (p1, p2)
Point p4 = p1 - p2;
```

With this update, your program now compiles, and you find you are able to add and subtract Point objects, as shown in the following output:

```
ptOne = [100, 100]
ptTwo = [40, 40]
ptOne + ptTwo: [140, 140]
ptOne - ptTwo: [60, 60]
```

When you are overloading a binary operator, you are not required to pass in two parameters of the same type. If it makes sense to do so, one of the arguments can differ. For example, here is an overloaded operator + that allows the caller to obtain a new Point that is based on a numerical adjustment:

```
public class Point
{
    ...
    public static Point operator + (Point p1, int change)
    {
        return new Point(p1.X + change, p1.Y + change);
    }

    public static Point operator + (int change, Point p1)
    {
        return new Point(p1.X + change, p1.Y + change);
    }
}
```

Notice that you need *both* versions of the method if you want the arguments to be passed in either order (i.e., you can't just define one of the methods and expect the compiler to automatically support the other one). You are now able to use these new versions of operator + as follows:

```
// Prints [110, 110].
Point biggerPoint = ptOne + 10;
Console.WriteLine("ptOne + 10 = {0}", biggerPoint);

// Prints [120, 120].
Console.WriteLine("10 + biggerPoint = {0}", 10 + biggerPoint);
Console.WriteLine();
```

And What of the += and -= Operators?

If you are coming to C# from a C++ background, you might lament the loss of overloading the shorthand assignment operators (+, -=, and so forth). Don't despair. In terms of C#, the shorthand assignment operators are automatically simulated if a type overloads the related binary operator. Thus, given that the Point structure has already overloaded the + and - operators, you can write the following:

```
// Overloading binary operators results in a freebie shorthand operator.
static void Main(string[] args)
{
    ...
    // Freebie +=
    Point ptThree = new Point(90, 5);
    Console.WriteLine("ptThree = {0}", ptThree);
    Console.WriteLine("ptThree += ptTwo: {0}", ptThree += ptTwo);

    // Freebie -=
    Point ptFour = new Point(0, 500);
    Console.WriteLine("ptFour = {0}", ptFour);
    Console.WriteLine("ptFour -= ptThree: {0}", ptFour -= ptThree);
    Console.ReadLine();
}
```

Overloading Unary Operators

C# also allows you to overload various unary operators, such as ++ and --. When you overload a unary operator, you also must use the static keyword with the operator keyword; however, in this case you simply pass in a single parameter that is the same type as the defining class/structure. For example, if you were to update the Point with the following overloaded operators:

```
public class Point
{
    ...
    // Add 1 to the X/Y values for the incoming Point.
    public static Point operator ++(Point p1)
    {
        return new Point(p1.X+1, p1.Y+1);
    }

    // Subtract 1 from the X/Y values for the incoming Point.
    public static Point operator --(Point p1)
    {
        return new Point(p1.X-1, p1.Y-1);
    }
}
```

you could increment and decrement Point's x and y values like this:

```
static void Main(string[] args)
{
    ...
    // Applying the ++ and -- unary operators to a Point.
    Point ptFive = new Point(1, 1);
    Console.WriteLine("++ptFive = {0}", ++ptFive); // [2, 2]
    Console.WriteLine("--ptFive = {0}", --ptFive); // [1, 1]

    // Apply same operators as postincrement/decrement.
    Point ptSix = new Point(20, 20);
    Console.WriteLine("ptSix++ = {0}", ptSix++); // [20, 20]
    Console.WriteLine("ptSix-- = {0}", ptSix--); // [21, 21]
    Console.ReadLine();
}
```

Notice in the preceding code example you are applying the custom ++ and -- operators in two different manners. In C++, it is possible to overload pre- and postincrement/decrement operators separately. This is not possible in C#. However, the return value of the increment/decrement is automatically handled “correctly” free of charge (i.e., for an overloaded ++ operator, pt++ has the value of the unmodified object as its value within an expression, while ++pt has the new value applied before use in the expression).

Overloading Equality Operators

As you might recall from Chapter 6, `System.Object.Equals()` can be overridden to perform value-based (rather than referenced-based) comparisons between reference types. If you choose to override `Equals()` (and the often related `System.Object.GetHashCode()` method), it is trivial to overload the equality operators (`==` and `!=`). To illustrate, here is the updated Point type:

```
// This incarnation of Point also overloads the == and != operators.
public class Point
{
    ...
    public override bool Equals(object o)
    {
        return o.ToString() == this.ToString();
    }

    public override int GetHashCode()
    {
        return this.ToString().GetHashCode();
    }

    // Now let's overload the == and != operators.
    public static bool operator ==(Point p1, Point p2)
    {
        return p1.Equals(p2);
    }
}
```

```

public static bool operator !=(Point p1, Point p2)
{
    return !p1.Equals(p2);
}
}

```

Notice how the implementation of operator == and operator != simply makes a call to the overridden Equals() method to get the bulk of the work done. Given this, you can now exercise your Point class as follows:

```

// Make use of the overloaded equality operators.
static void Main(string[] args)
{
    ...
    Console.WriteLine("ptOne == ptTwo : {0}", ptOne == ptTwo);
    Console.WriteLine("ptOne != ptTwo : {0}", ptOne != ptTwo);
    Console.ReadLine();
}

```

As you can see, it is quite intuitive to compare two objects using the well-known == and != operators, rather than making a call to Object.Equals(). If you do overload the equality operators for a given class, keep in mind that C# demands that if you override the == operator, you *must* also override the != operator (if you forget, the compiler will let you know).

Overloading Comparison Operators

In Chapter 8, you learned how to implement the IComparable interface to compare the relationship between two like objects. You can, in fact, also overload the comparison operators (<, >, <=, and >=) for the same class. As with the equality operators, C# demands that if you overload <, you must also overload >. The same holds true for the <= and >= operators. If the Point type overloaded these comparison operators, the object user could now compare Points, as follows:

```

// Using the overloaded < and > operators.
static void Main(string[] args)
{
    ...
    Console.WriteLine("ptOne < ptTwo : {0}", ptOne < ptTwo);
    Console.WriteLine("ptOne > ptTwo : {0}", ptOne > ptTwo);
    Console.ReadLine();
}

```

Assuming you have implemented the IComparable interface (or better yet, the generic equivalent), overloading the comparison operators is trivial. Here is the updated class definition:

```

// Point is also comparable using the comparison operators.
public class Point : IComparable<Point>
{
    ...
    public int CompareTo(Point other)
    {
        if (this.X > other.X && this.Y > other.Y)
            return 1;
    }
}

```

```

    if (this.X < other.X && this.Y < other.Y)
        return -1;
    else
        return 0;
}

public static bool operator <(Point p1, Point p2)
{ return (p1.CompareTo(p2) < 0); }

public static bool operator >(Point p1, Point p2)
{ return (p1.CompareTo(p2) > 0); }

public static bool operator <=(Point p1, Point p2)
{ return (p1.CompareTo(p2) <= 0); }

public static bool operator >=(Point p1, Point p2)
{ return (p1.CompareTo(p2) >= 0); }
}

```

Final Thoughts Regarding Operator Overloading

As you have seen, *C#* provides the capability to build types that can respond uniquely to various intrinsic, well-known operators. Now, before you go and retrofit all your classes to support such behavior, you must be sure that the operators you are about to overload make some sort of logical sense in the world at large.

For example, let's say you overloaded the multiplication operator for the *MiniVan* class. What exactly would it mean to multiply two *MiniVan* objects? Not much. In fact, it would be confusing for teammates to see the following use of *MiniVan* objects:

```
// Huh?! This is far from intuitive...
MiniVan newVan = myVan * yourVan;
```

Overloading operators is generally useful only when you're building atomic data types. Text, points, rectangles, fractions, and hexagons make good candidates for operator overloading. People, managers, cars, database connections, and web pages do not. As a rule of thumb, if an overloaded operator makes it *harder* for the user to understand a type's functionality, don't do it. Use this feature wisely.

■ **Source Code** The *OverloadedOps* project is located in the [Chapter 11](#) subdirectory.

Understanding Custom Type Conversions

Let's now examine a topic closely related to operator overloading: custom type conversions. To set the stage for the discussion, let's quickly review the notion of explicit and implicit conversions between numerical data and related class types.

Recall: Numerical Conversions

In terms of the intrinsic numerical types (sbyte, int, float, etc.), an *explicit conversion* is required when you attempt to store a larger value in a smaller container, as this could result in a loss of data. Basically, this is your way to tell the compiler, “Leave me alone, I know what I am trying to do.” Conversely, an *implicit conversion* happens automatically when you attempt to place a smaller type in a destination type that will not result in a loss of data.

```
static void Main()
{
    int a = 123;
    long b = a;        // Implicit conversion from int to long.
    int c = (int) b;   // Explicit conversion from long to int.
}
```

Recall: Conversions Among Related Class Types

As shown in Chapter 6, class types may be related by classical inheritance (the “is-a” relationship). In this case, the C# conversion process allows you to cast up and down the class hierarchy. For example, a derived class can always be implicitly cast to a base type. However, if you want to store a base class type in a derived variable, you must perform an explicit cast, like so:

```
// Two related class types.
class Base{}
class Derived : Base{}

class Program
{
    static void Main(string[] args)
    {
        // Implicit cast between derived to base.
        Base myBaseType;
        myBaseType = new Derived();

        // Must explicitly cast to store base reference
        // in derived type.
        Derived myDerivedType = (Derived)myBaseType;
    }
}
```

This explicit cast works because the Base and Derived classes are related by classical inheritance. However, what if you have two class types in *different hierarchies* with no common parent (other than System.Object) that require conversions? Given that they are not related by classical inheritance, typical casting operations offer no help (and you would get a compiler error to boot!).

On a related note, consider value types (structures). Assume you have two .NET structures named Square and Rectangle. Given that structures cannot leverage classic inheritance (as they are always sealed), you have no natural way to cast between these seemingly related types.

While you could create helper methods in the structures (such as `Rectangle.ToSquare()`), C# lets you build custom conversion routines that allow your types to respond to the `()` casting operator. Therefore, if you configured the structures correctly, you would be able to use the following syntax to explicitly convert between them as follows:

```
// Convert a Rectangle to a Square!
Rectangle rect;
rect.Width = 3;
rect.Height = 10;
Square sq = (Square)rect;
```

Creating Custom Conversion Routines

Begin by creating a new Console Application project named `CustomConversions`. C# provides two keywords, `explicit` and `implicit`, that you can use to control how your types respond during an attempted conversion. Assume you have the following structure definitions:

```
public struct Rectangle
{
    public int Width {get; set;}
    public int Height {get; set;}

    public Rectangle(int w, int h) : this()
    {
        Width = w; Height = h;
    }

    public void Draw()
    {
        for (int i = 0; i < Height; i++)
        {
            for (int j = 0; j < Width; j++)
            {
                Console.Write("*");
            }
            Console.WriteLine();
        }
    }

    public override string ToString()
    {
        return string.Format("[Width = {0}; Height = {1}]",
            Width, Height);
    }
}
```

```

public struct Square
{
    public int Length {get; set;}
    public Square(int l) : this()
    {
        Length = l;
    }

    public void Draw()
    {
        for (int i = 0; i < Length; i++)
        {
            for (int j = 0; j < Length; j++)
            {
                Console.Write("*");
            }
            Console.WriteLine();
        }
    }

    public override string ToString()
    { return string.Format("[Length = {0}]", Length); }

    // Rectangles can be explicitly converted
    // into Squares.
    public static explicit operator Square(Rectangle r)
    {
        Square s = new Square();
        s.Length = r.Height;
        return s;
    }
}

```

■ **Note** You'll notice in the `Square` and `Rectangle` constructors, I am explicitly chaining to the default constructor. The reason is that if you have a structure, which makes use of automatic property syntax (as you do here), the default constructor must be explicitly called (from all custom constructors) to initialize the private backing fields (for example, if the structures had any additional fields/properties, this default constructor would initialize these fields to default values). Yes, this is a quirky rule of C#, but after all, this is an advanced topics chapter.

Notice that this iteration of the `Square` type defines an explicit conversion operator. Like the process of overloading an operator, conversion routines make use of the C# `operator` keyword, in conjunction with the `explicit` or `implicit` keyword, and must be defined as `static`. The incoming parameter is the entity you are converting *from*, while the operator type is the entity you are converting *to*.

In this case, the assumption is that a square (being a geometric pattern in which all sides are of equal length) can be obtained from the height of a rectangle. Thus, you are free to convert a `Rectangle` into a `Square`, as follows:

```
static void Main(string[] args)
{
    Console.WriteLine("***** Fun with Conversions *****\n");
    // Make a Rectangle.
    Rectangle r = new Rectangle(15, 4);
    Console.WriteLine(r.ToString());
    r.Draw();

    Console.WriteLine();

    // Convert r into a Square,
    // based on the height of the Rectangle.
    Square s = (Square)r;
    Console.WriteLine(s.ToString());
    s.Draw();
    Console.ReadLine();
}
```

You can see the output here:

```
***** Fun with Conversions *****

[Width = 15; Height = 4]

*****
*****
*****
*****

[Length = 4]
****
****
****
****
```

While it may not be all that helpful to convert a `Rectangle` into a `Square` within the same scope, assume you have a function that has been designed to take `Square` parameters.

```
// This method requires a Square type.
static void DrawSquare(Square sq)
{
    Console.WriteLine(sq.ToString());
    sq.Draw();
}
```

Using your explicit conversion operation on the Square type, you can now pass in Rectangle types for processing using an explicit cast, like so:

```
static void Main(string[] args)
{
    ...
    // Convert Rectangle to Square to invoke method.
    Rectangle rect = new Rectangle(10, 5);
    DrawSquare((Square)rect);
    Console.ReadLine();
}
```

Additional Explicit Conversions for the Square Type

Now that you can explicitly convert Rectangles into Squares, let's examine a few additional explicit conversions. Given that a square is symmetrical on all sides, it might be helpful to provide an explicit conversion routine that allows the caller to cast from an integer type into a Square (which, of course, will have a side length equal to the incoming integer). Likewise, what if you were to update Square such that the caller can cast *from* a Square into an int? Here is the calling logic:

```
static void Main(string[] args)
{
    ...
    // Converting an int to a Square.
    Square sq2 = (Square)90;
    Console.WriteLine("sq2 = {0}", sq2);

    // Converting a Square to an int.
    int side = (int)sq2;
    Console.WriteLine("Side length of sq2 = {0}", side);
    Console.ReadLine();
}
```

and here is the update to the Square class:

```
public struct Square
{
    ...
    public static explicit operator Square(int sideLength)
    {
        Square newSq = new Square();
        newSq.Length = sideLength;
        return newSq;
    }

    public static explicit operator int (Square s)
    {return s.Length;}
}
```

To be honest, converting from a Square into an integer may not be the most intuitive (or useful) operation (after all, chances are you could just pass such values to a constructor). However, it does point out an important fact regarding custom conversion routines: the compiler does not care what you convert to or from, as long as you have written syntactically correct code.

Thus, as with overloading operators, just because you *can* create an explicit cast operation for a given type does not mean you *should*. Typically, this technique will be most helpful when you're creating .NET structure types, given that they are unable to participate in classical inheritance (where casting comes for free).

Defining Implicit Conversion Routines

So far, you have created various custom *explicit* conversion operations. However, what about the following *implicit* conversion?

```
static void Main(string[] args)
{
    ...
    Square s3 = new Square();
    s3.Length = 83;

    // Attempt to make an implicit cast?
    Rectangle rect2 = s3;

    Console.ReadLine();
}
```

This code will not compile, given that you have not provided an implicit conversion routine for the Rectangle type. Now here is the catch: it is illegal to define explicit and implicit conversion functions on the same type if they do not differ by their return type or parameter set. This might seem like a limitation; however, the second catch is that when a type defines an *implicit* conversion routine, it is legal for the caller to make use of the *explicit* cast syntax!

Confused? To clear things up, let's add an implicit conversion routine to the Rectangle structure using the C# `implicit` keyword (note that the following code assumes the width of the resulting Rectangle is computed by multiplying the side of the Square by 2):

```
public struct Rectangle
{
    ...
    public static implicit operator Rectangle(Square s)
    {
        Rectangle r = new Rectangle();
        r.Height = s.Length;

        // Assume the length of the new Rectangle with
        // (Length x 2).
        r.Width = s.Length * 2;
        return r;
    }
}
```

With this update, you are now able to convert between types, as follows:

```
static void Main(string[] args)
{
    ...
    // Implicit cast OK!
    Square s3 = new Square();
    s3.Length = 7;

    Rectangle rect2 = s3;
    Console.WriteLine("rect2 = {0}", rect2);

    // Explicit cast syntax still OK!
    Square s4 = new Square();
    s4.Length = 3;
    Rectangle rect3 = (Rectangle)s4;

    Console.WriteLine("rect3 = {0}", rect3);
    Console.ReadLine();
}
```

That wraps up your look at defining custom conversion routines. As with overloaded operators, remember that this bit of syntax is simply a shorthand notation for “normal” member functions, and in this light it is always optional. When used correctly, however, custom structures can be used more naturally, as they can be treated as true class types related by inheritance.

■ **Source Code** The CustomConversions project is located in the Chapter 11 subdirectory.

Understanding Extension Methods

.NET 3.5 introduced the concept of *extension methods*, which allow you to add new methods or properties to a class or structure, without modifying the original type in any direct manner. So, where might this be helpful? Consider the following possibilities.

First, say you have a given class that is in production. It becomes clear over time that this class should support a handful of new members. If you modify the current class definition directly, you risk the possibility of breaking backward compatibility with older code bases making use of it, as they might not have been compiled with the latest and greatest class definition. One way to ensure backward compatibility is to create a new derived class from the existing parent; however, now you have two classes to maintain. As we all know, code maintenance is the least glamorous part of a software engineer’s job description.

Now consider this situation. Let’s say you have a structure (or maybe a sealed class) and want to add new members so that it behaves polymorphically in your system. Since structures and sealed classes cannot be extended, your only choice is to add the members to the type, once again risking backward compatibility!

Using extension methods, you are able to modify types without subclassing and without modifying the type directly. To be sure, this technique is essentially a smoke-and-mirror show. The new functionality is offered to a type only if the extension methods have been referenced for use in your current project.

Defining Extension Methods

When you define extension methods, the first restriction is that they must be defined within a static class (see Chapter 5) and, therefore, each extension method must be declared with the `static` keyword. The second point is that all extension methods are marked as such by using the `this` keyword as a modifier on the first (and only the first) parameter of the method in question. The “this qualified” parameter represents the item being extended.

To illustrate, create a new Console Application project named `ExtensionMethods`. Now, assume you are authoring a class named `MyExtensions` that defines two extension methods. The first method allows any object to use a new method named `DisplayDefiningAssembly()` that makes use of types in the `System.Reflection` namespace to display the name of the assembly containing the type in question.

■ **Note** You will formally examine the reflection API in Chapter 15. If you are new to the topic, simply understand that reflection allows you to discover the structure of assemblies, types, and type members at runtime.

The second extension method, named `ReverseDigits()`, allows any `int` to obtain a new version of itself where the value is reversed digit by digit. For example, if an integer with the value 1234 called `ReverseDigits()`, the integer returned is set to the value 4321. Consider the following class implementation (be sure to import the `System.Reflection` namespace if you are following along):

```
static class MyExtensions
{
    // This method allows any object to display the assembly
    // it is defined in.
    public static void DisplayDefiningAssembly(this object obj)
    {
        Console.WriteLine("{0} lives here: => {1}\n", obj.GetType().Name,
            Assembly.GetAssembly(obj.GetType()).GetName().Name);
    }

    // This method allows any integer to reverse its digits.
    // For example, 56 would return 65.
    public static int ReverseDigits(this int i)
    {
        // Translate int into a string, and then
        // get all the characters.
        char[] digits = i.ToString().ToCharArray();

        // Now reverse items in the array.
        Array.Reverse(digits);

        // Put back into string.
        string newDigits = new string(digits);

        // Finally, return the modified string back as an int.
        return int.Parse(newDigits);
    }
}
```

Again, note how the first parameter of each extension method has been qualified with the `this` keyword, before defining the parameter type. It is always the case that the first parameter of an extension method represents the type being extended. Given that `DisplayDefiningAssembly()` has been prototyped to extend `System.Object`, every type now has this new member, as `Object` is the parent to all types in the .NET platform. However, `ReverseDigits()` has been prototyped to extend only integer types; therefore, if anything other than an integer attempts to invoke this method, you will receive a compile-time error.

■ **Note** Understand that a given extension method can have multiple parameters, but *only* the first parameter can be qualified with `this`. The additional parameters would be treated as normal incoming parameters for use by the method.

Invoking Extension Methods

Now that you have these extension methods in place, consider the following `Main()` method that applies the extension method to various types in the base class libraries:

```
static void Main(string[] args)
{
    Console.WriteLine("***** Fun with Extension Methods *****\n");

    // The int has assumed a new identity!
    int myInt = 12345678;
    myInt.DisplayDefiningAssembly();

    // So has the DataSet!
    System.Data.DataSet d = new System.Data.DataSet();
    d.DisplayDefiningAssembly();

    // And the SoundPlayer!
    System.Media.SoundPlayer sp = new System.Media.SoundPlayer();
    sp.DisplayDefiningAssembly();

    // Use new integer functionality.
    Console.WriteLine("Value of myInt: {0}", myInt);
    Console.WriteLine("Reversed digits of myInt: {0}", myInt.ReverseDigits());

    Console.ReadLine();
}
```

Here is the output:

```
***** Fun with Extension Methods *****

Int32 lives here: => mscorlib

DataSet lives here: => System.Data

SoundPlayer lives here: => System

Value of myInt: 12345678
Reversed digits of myInt: 87654321
```

Importing Extension Methods

When you define a class containing extension methods, it will no doubt be defined within a .NET namespace. If this namespace is different from the namespace using the extension methods, you will need to make use of the expected C# `using` keyword. When you do, your code file has access to all extension methods for the type being extended. This is important to remember, because if you do not explicitly import the correct namespace, the extension methods are not available for that C# code file.

In effect, although it can appear on the surface that extension methods are global in nature, they are in fact limited to the namespaces that define them or the namespaces that import them. Thus, if you wrap the `MyExtensions` class into a namespace named `MyExtensionMethods`, as follows:

```
namespace MyExtensionMethods
{
    static class MyExtensions
    {
        ...
    }
}
```

other namespaces in the project would need to explicitly import the `MyExtensionMethods` namespace to gain the extension methods defined by your class.

■ **Note** It is common practice to not only isolate extension methods into a dedicated .NET namespace but into a dedicated class library. In this way, new applications can “opt in” to extensions by explicitly referencing the correct library and importing the namespace. Chapter 14 will examine the details of building and using custom .NET class libraries.

The IntelliSense of Extension Methods

Given that extension methods are not literally defined on the type being extended, it is certainly possible to become confused when examining an existing code base. For example, assume you have imported a namespace that defined some number of extension methods authored by a teammate. As you are authoring your code, you might create a variable of the extended type, apply the dot operator, and find dozens of new methods that are not members of the original class definition!

Thankfully, Visual Studio's IntelliSense mechanism marks all extension methods as shown in Figure 11-1.

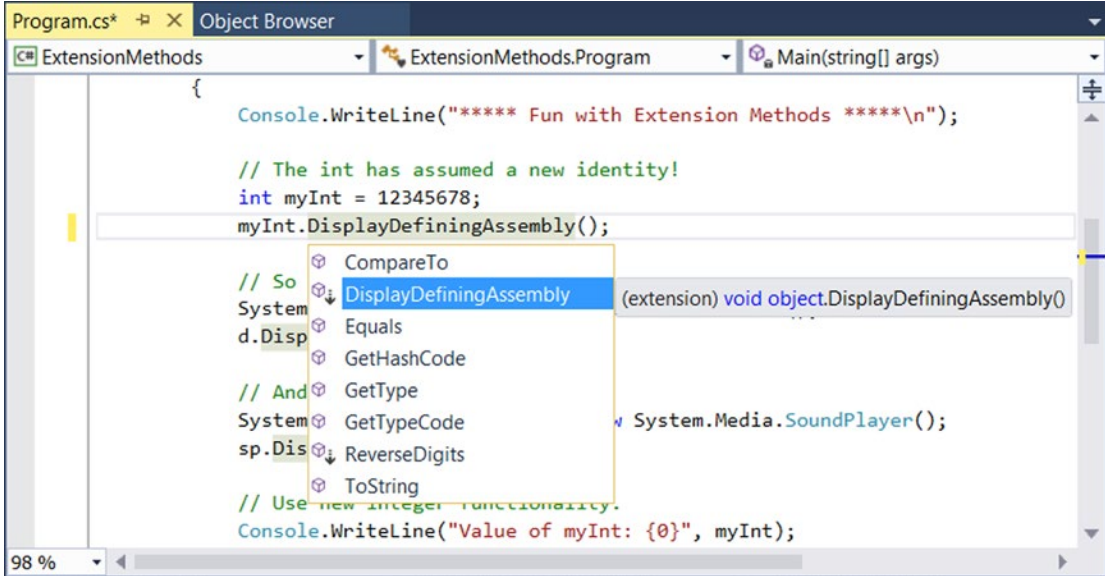

Figure 11-1. The IntelliSense of extension methods

Any method marked as such is a friendly reminder that the method is defined outside of the original class definition via an extension method.

■ **Source Code** The ExtensionMethods project can be found in the Chapter 11 subdirectory.

Extending Types Implementing Specific Interfaces

At this point, you have seen how to extend classes (and, indirectly, structures that follow the same syntax) with new functionality via extension methods. It is also possible to define an extension method that can only extend a class or structure that implements the correct interface. For example, you could say something to the effect of “If a class or structure implements IEnumerable<T>, then that type gets the following new members.” Of course, it is possible to demand that a type support any interface at all, including your own custom interfaces.

To illustrate, create a new Console Application project named `InterfaceExtensions`. The goal here is to add a new method to any type that implements `IEnumerable`, which would include any array and many nongeneric collection classes (recall from Chapter 8 that the generic `IEnumerable<T>` interface extends the nongeneric `IEnumerable` interface). Add the following extension class to your new project:

```
static class AnnoyingExtensions
{
    public static void PrintDataAndBeep(this System.Collections.IEnumerable iterator)
    {
        foreach (var item in iterator)
        {
            Console.WriteLine(item);
            Console.Beep();
        }
    }
}
```

Given that the `PrintDataAndBeep()` method can be used by any class or structure that implements `IEnumerable`, you could test via the following `Main()` method:

```
static void Main( string[] args )
{
    Console.WriteLine("***** Extending Interface Compatible Types *****\n");

    // System.Array implements IEnumerable!
    string[] data = { "Wow", "this", "is", "sort", "of", "annoying",
                    "but", "in", "a", "weird", "way", "fun!" };
    data.PrintDataAndBeep();

    Console.WriteLine();

    // List<T> implements IEnumerable!
    List<int> myInts = new List<int>() {10, 15, 20};
    myInts.PrintDataAndBeep();

    Console.ReadLine();
}
```

That wraps up your examination of C# extension methods. Remember that this particular language feature can be useful whenever you want to extend the functionality of a type but do not want to subclass (or cannot subclass if the type is sealed), for the purposes of polymorphism. As you will see later in the text, extension methods play a key role for LINQ APIs. In fact, you will see that under the LINQ APIs, one of the most common items being extended is a class or structure implementing (surprise!) the generic version of `IEnumerable`.

■ **Source Code** The `InterfaceExtension` project can be found in the Chapter 11 subdirectory.

Understanding Anonymous Types

As an object-oriented programmer, you know the benefits of defining classes to represent the state and functionality of a given item you are attempting to model. To be sure, whenever you need to define a class that is intended to be reused across projects and that provides numerous bits of functionality through a set of methods, events, properties, and custom constructors, creating a new C# class is common practice.

However, there are other times when you would like to define a class simply to model a set of encapsulated (and somehow related) data points without any associated methods, events, or other specialized functionality. Furthermore, what if this type is to be used only by a handful of methods in your program? It would be rather a bother to define a full class definition as shown next when you know full well this class will be used in only a handful of places. To accentuate this point, here is the rough outline of what you might need to do when you need to create a “simple” data type that follows typical value-based semantics:

```
class SomeClass
{
    // Define a set of private member variables...

    // Make a property for each member variable...

    // Override ToString() to account for key member variables...

    // Override GetHashCode() and Equals() to work with value-based equality...
}
```

As you can see, it is not necessarily so simple. Not only do you need to author a fair amount of code, but you have another class to maintain in your system. For temporary data such as this, it would be useful to whip up a custom data type on the fly. For example, let’s say you need to build a custom method that receives a set of incoming parameters. You would like to take these parameters and use them to create a new data type for use in this method scope. Further, you would like to quickly print out this data using the typical `ToString()` method and perhaps use other members of `System.Object`. You can do this very thing using anonymous type syntax.

Defining an Anonymous Type

When you define an anonymous type, you do so by using the `var` keyword (see Chapter 3) in conjunction with object initialization syntax (see Chapter 5). You must use the `var` keyword because the compiler will automatically generate a new class definition at compile time (and you never see the name of this class in your C# code). The initialization syntax is used to tell the compiler to create private backing fields and (read-only) properties for the newly created type.

To illustrate, create a new Console Application project named `AnonymousTypes`. Now, add the following method to your `Program` class, which composes a new type, on the fly, using the incoming parameter data:

```
static void BuildAnonType( string make, string color, int currSp )
{
    // Build anon type using incoming args.
    var car = new { Make = make, Color = color, Speed = currSp };
}
```

```
// Note you can now use this type to get the property data!
Console.WriteLine("You have a {0} {1} going {2} MPH",
    car.Color, car.Make, car.Speed);

// Anon types have custom implementations of each virtual
// method of System.Object. For example:
Console.WriteLine("ToString() == {0}", car.ToString());
}
```

You can call this method from `Main()`, as expected. However, do note that an anonymous type can also be created using hard-coded values, as shown here:

```
static void Main(string[] args)
{
    Console.WriteLine("***** Fun with Anonymous Types *****\n");

    // Make an anonymous type representing a car.
    var myCar = new { Color = "Bright Pink", Make = "Saab", CurrentSpeed = 55 };

    // Now show the color and make.
    Console.WriteLine("My car is a {0} {1}.", myCar.Color, myCar.Make);

    // Now call our helper method to build anonymous type via args.
    BuildAnonType("BMW", "Black", 90);

    Console.ReadLine();
}
```

So, at this point, simply understand that anonymous types allow you to quickly model the “shape” of data with very little overhead. This technique is little more than a way to whip up a new data type on the fly, which supports bare-bones encapsulation via properties and acts according to value-based semantics. To understand that last point, let’s see how the C# compiler builds out anonymous types at compile time and, specifically, how it overrides the members of `System.Object`.

The Internal Representation of Anonymous Types

All anonymous types are automatically derived from `System.Object` and, therefore, support each of the members provided by this base class. Given this, you could invoke `ToString()`, `GetHashCode()`, `Equals()`, or `GetType()` on the implicitly typed `myCar` object. Assume your `Program` class defines the following static helper function:

```
static void ReflectOverAnonymousType(object obj)
{
    Console.WriteLine("obj is an instance of: {0}", obj.GetType().Name);
    Console.WriteLine("Base class of {0} is {1}",
        obj.GetType().Name,
        obj.GetType().BaseType);
    Console.WriteLine("obj.ToString() == {0}", obj.ToString());
    Console.WriteLine("obj.GetHashCode() == {0}", obj.GetHashCode());
    Console.WriteLine();
}
```

Now assume you invoke this method from `Main()`, passing in the `myCar` object as the parameter, like so:

```
static void Main(string[] args)
{
    Console.WriteLine("***** Fun with Anonymous Types *****\n");

    // Make an anonymous type representing a car.
    var myCar = new {Color = "Bright Pink", Make = "Saab", CurrentSpeed = 55};

    // Reflect over what the compiler generated.
    ReflectOverAnonymousType(myCar);
    ...

    Console.ReadLine();
}
```

The output will look similar to the following:

```
***** Fun with Anonymous Types *****

obj is an instance of: <>f__AnonymousType0`3
Base class of <>f__AnonymousType0`3 is System.Object
obj.ToString() = { Color = Bright Pink, Make = Saab, CurrentSpeed = 55 }
obj.GetHashCode() = -439083487
```

First, notice that, in this example, the `myCar` object is of type `<>f__AnonymousType0`3` (your name may differ). Remember that the assigned type name is completely determined by the compiler and is not directly accessible in your C# code base.

Perhaps most important, notice that each name-value pair defined using the object initialization syntax is mapped to an identically named read-only property and a corresponding private read-only backing field. The following C# code approximates the compiler-generated class used to represent the `myCar` object (which again can be verified using `ildasm.exe`):

```
internal sealed class <>f__AnonymousType0<<Color>j__TPar,
    <Make>j__TPar, <CurrentSpeed>j__TPar>
{
    // Read-only fields.
    private readonly <Color>j__TPar <Color>i__Field;
    private readonly <CurrentSpeed>j__TPar <CurrentSpeed>i__Field;
    private readonly <Make>j__TPar <Make>i__Field;

    // Default constructor.
    public <>f__AnonymousType0(<Color>j__TPar Color,
        <Make>j__TPar Make, <CurrentSpeed>j__TPar CurrentSpeed);
    // Overridden methods.
    public override bool Equals(object value);
    public override int GetHashCode();
    public override string ToString();
}
```

```

// Read-only properties.
public <Color>j_TPar Color { get; }
public <CurrentSpeed>j_TPar CurrentSpeed { get; }
public <Make>j_TPar Make { get; }
}

```

The Implementation of ToString() and GetHashCode()

All anonymous types automatically derive from `System.Object` and are provided with an overridden version of `Equals()`, `GetHashCode()`, and `ToString()`. The `ToString()` implementation simply builds a string from each name-value pair. Here's an example:

```

public override string ToString()
{
    StringBuilder builder = new StringBuilder();
    builder.Append("{ Color = ");
    builder.Append(this.<Color>i__Field);
    builder.Append(", Make = ");
    builder.Append(this.<Make>i__Field);
    builder.Append(", CurrentSpeed = ");
    builder.Append(this.<CurrentSpeed>i__Field);
    builder.Append(" }");
    return builder.ToString();
}

```

The `GetHashCode()` implementation computes a hash value using each anonymous type's member variables as input to the `System.Collections.Generic.EqualityComparer<T>` type. Using this implementation of `GetHashCode()`, two anonymous types will yield the same hash value if (and only if) they have the same set of properties that have been assigned the same values. Given this implementation, anonymous types are well-suited to be contained within a `Hashtable` container.

The Semantics of Equality for Anonymous Types

While the implementation of the overridden `ToString()` and `GetHashCode()` methods is fairly straightforward, you might be wondering how the `Equals()` method has been implemented. For example, if you were to define two "anonymous cars" variables that specify the same name-value pairs, would these two variables be considered equal? To see the results firsthand, update your `Program` type with the following new method:

```

static void EqualityTest()
{
    // Make 2 anonymous classes with identical name/value pairs.
    var firstCar = new { Color = "Bright Pink", Make = "Saab", CurrentSpeed = 55 };
    var secondCar = new { Color = "Bright Pink", Make = "Saab", CurrentSpeed = 55 };

    // Are they considered equal when using Equals()?
    if (firstCar.Equals(secondCar))
        Console.WriteLine("Same anonymous object!");
    else
        Console.WriteLine("Not the same anonymous object!");
}

```

```

// Are they considered equal when using ==?
if (firstCar == secondCar)
    Console.WriteLine("Same anonymous object!");
else
    Console.WriteLine("Not the same anonymous object!");

// Are these objects the same underlying type?
if (firstCar.GetType().Name == secondCar.GetType().Name)
    Console.WriteLine("We are both the same type!");
else
    Console.WriteLine("We are different types!");

// Show all the details.
Console.WriteLine();
ReflectOverAnonymousType(firstCar);
ReflectOverAnonymousType(secondCar);
}

```

Assuming you have called this method from within `Main()`, here is the (somewhat surprising) output:

```

My car is a Bright Pink Saab.
You have a Black BMW going 90 MPH
ToString() == { Make = BMW, Color = Black, Speed = 90 }

```

```

Same anonymous object!
Not the same anonymous object!
We are both the same type!

```

```

obj is an instance of: <>f__AnonymousType0`3
Base class of <>f__AnonymousType0`3 is System.Object
obj.ToString() == { Color = Bright Pink, Make = Saab, CurrentSpeed = 55 }
obj.GetHashCode() == -439083487

```

```

obj is an instance of: <>f__AnonymousType0`3
Base class of <>f__AnonymousType0`3 is System.Object
obj.ToString() == { Color = Bright Pink, Make = Saab, CurrentSpeed = 55 }
obj.GetHashCode() == -439083487

```

When you run this test code, you will see that the first conditional test where you call `Equals()` returns true and, therefore, the message “Same anonymous object!” prints out to the screen. This is because the compiler-generated `Equals()` method uses value-based semantics when testing for equality (e.g., checking the value of each field of the objects being compared).

However, the second conditional test, which makes use of the C# equality operator (`==`), prints out “Not the same anonymous object!” This might seem at first glance to be a bit counterintuitive. This result is because anonymous types do *not* receive overloaded versions of the C# equality operators (`==` and `!=`). Given this, when you test for equality of anonymous types using the C# equality operators (rather than the `Equals()` method), the *references*, not the values maintained by the objects, are being tested for equality.

Last but not least, in the final conditional test (where you examine the underlying type name), you find that the anonymous types are instances of the same compiler-generated class type (in this example, `<>f__AnonymousType0`3`) because `firstCar` and `secondCar` have the same properties (`Color`, `Make`, and `CurrentSpeed`).

This illustrates an important but subtle point: the compiler will generate a new class definition only when an anonymous type contains *unique* names of the anonymous type. Thus, if you declare identical anonymous types (again, meaning the same names) within the same assembly, the compiler generates only a single anonymous type definition.

Anonymous Types Containing Anonymous Types

It is possible to create an anonymous type that is composed of other anonymous types. For example, assume you want to model a purchase order that consists of a timestamp, a price point, and the automobile purchased. Here is a new (slightly more sophisticated) anonymous type representing such an entity:

```
// Make an anonymous type that is composed of another.
var purchaseItem = new {
    TimeBought = DateTime.Now,
    ItemBought = new {Color = "Red", Make = "Saab", CurrentSpeed = 55},
    Price = 34.000};

ReflectOverAnonymousType(purchaseItem);
```

At this point, you should understand the syntax used to define anonymous types, but you might still be wondering exactly where (and when) to use this new language feature. To be blunt, anonymous type declarations should be used sparingly, typically only when making use of the LINQ technology set (see Chapter 12). You would never want to abandon the use of strongly typed classes/structures simply for the sake of doing so, given anonymous types' numerous limitations, which include the following:

- You don't control the name of the anonymous type.
- Anonymous types always extend `System.Object`.
- The fields and properties of an anonymous type are always read-only.
- Anonymous types cannot support events, custom methods, custom operators, or custom overrides.
- Anonymous types are always implicitly sealed.
- Anonymous types are always created using the default constructor.

However, when programming with the LINQ technology set, you will find that in many cases this syntax can be helpful when you want to quickly model the overall *shape* of an entity rather than its functionality.

■ **Source Code** The `AnonymousTypes` project can be found in the Chapter 11 subdirectory.

Working with Pointer Types

And now for the final topic of the chapter, which most likely will be the least used of all C# features for the vast majority of your .NET projects.

■ **Note** In the examples that follow, I'm assuming you have some background in C++ pointer manipulation. If this is not true, feel free to skip this topic entirely. Using pointers will not be a common task for the vast majority of C# applications.

In Chapter 4, you learned that the .NET platform defines two major categories of data: value types and reference types. Truth be told, however, there is a third category: *pointer types*. To work with pointer types, you get specific operators and keywords that allow you to bypass the CLR's memory-management scheme and take matters into your own hands (see Table 11-2).

Table 11-2. *Pointer-Centric C# Operators and Keywords*

| Operator/Keyword | Meaning in Life |
|----------------------|---|
| * | This operator is used to create a pointer variable (i.e., a variable that represents a direct location in memory). As in C++, this same operator is used for pointer indirection. |
| & | This operator is used to obtain the address of a variable in memory. |
| -> | This operator is used to access fields of a type that is represented by a pointer (the unsafe version of the C# dot operator). |
| [] | This operator (in an unsafe context) allows you to index the slot pointed to by a pointer variable (if you're a C++ programmer, you will recall the interplay between a pointer variable and the [] operator). |
| ++, -- | In an unsafe context, the increment and decrement operators can be applied to pointer types. |
| +, - | In an unsafe context, the addition and subtraction operators can be applied to pointer types. |
| ==, !=, <, >, <=, => | In an unsafe context, the comparison and equality operators can be applied to pointer types. |
| stackalloc | In an unsafe context, the <code>stackalloc</code> keyword can be used to allocate C# arrays directly on the stack. |
| fixed | In an unsafe context, the <code>fixed</code> keyword can be used to temporarily fix a variable so that its address can be found. |

Now, before digging into the details, let me again point out that you will *seldom if ever* need to make use of pointer types. Although C# does allow you to drop down to the level of pointer manipulations, understand that the .NET runtime has absolutely no clue of your intentions. Thus, if you mismanage a pointer, you are the one in charge of dealing with the consequences. Given these warnings, when exactly would you need to work with pointer types? There are two common situations:

- You are looking to optimize select parts of your application by directly manipulating memory outside the management of the CLR.
- You are calling methods of a C-based .dll or COM server that demand pointer types as parameters. Even in this case, you can often bypass pointer types in favor of the `System.IntPtr` type and members of the `System.Runtime.InteropServices.Marshal` type.

In the event that you do decide to make use of this C# language feature, you are required to inform the C# compiler (`csc.exe`) of your intentions by enabling your project to support “unsafe code.” To do so at the command line, simply supply the following `/unsafe` flag as an argument:

```
csc /unsafe *.cs
```

From Visual Studio, you will need to access your project’s Properties page and check the Allow Unsafe Code box on the Build tab (see Figure 11-2). To experiment with pointer types, create a new Console Application project named `UnsafeCode` and enable unsafe code, and make sure you enable this setting.

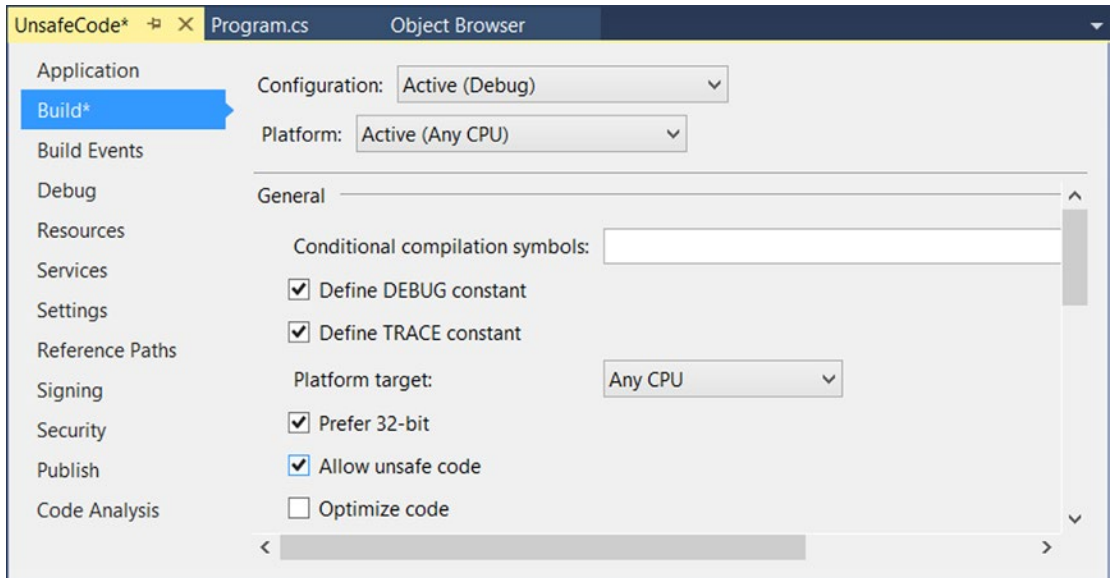

Figure 11-2. Enabling unsafe code using Visual Studio

The unsafe Keyword

When you want to work with pointers in C#, you must specifically declare a block of “unsafe code” using the `unsafe` keyword (any code that is not marked with the `unsafe` keyword is considered “safe” automatically). For example, the following `Program` class declares a scope of unsafe code within the `Main()` method:

```
class Program
{
    static void Main(string[] args)
    {
        unsafe
        {
            // Work with pointer types here!
        }

        // Can't work with pointers here!
    }
}
```

In addition to declaring a scope of unsafe code within a method, you can build structures, classes, type members, and parameters that are “unsafe.” Here are a few examples to gnaw on (no need to define the Node or Node2 types in your current project):

```
// This entire structure is "unsafe" and can
// be used only in an unsafe context.
unsafe struct Node
{
    public int Value;
    public Node* Left;
    public Node* Right;
}

// This struct is safe, but the Node2* members
// are not. Technically, you may access "Value" from
// outside an unsafe context, but not "Left" and "Right".
public struct Node2
{
    public int Value;

    // These can be accessed only in an unsafe context!
    public unsafe Node2* Left;
    public unsafe Node2* Right;
}
```

Methods (static or instance level) may be marked as unsafe as well. For example, assume you know that a particular static method will make use of pointer logic. To ensure that this method can be called only from an unsafe context, you could define the method as follows:

```
unsafe static void SquareIntPtr(int* myIntPtr)
{
    // Square the value just for a test.
    *myIntPtr *= *myIntPtr;
}
```

The configuration of your method demands that the caller invoke SquareIntPtr() as follows:

```
static void Main(string[] args)
{
    unsafe
    {
        int myInt = 10;

        // OK, because we are in an unsafe context.
        SquareIntPtr(&myInt);
        Console.WriteLine("myInt: {0}", myInt);
    }

    int myInt2 = 5;
```

```
// Compiler error! Must be in unsafe context!
SquareIntPtr(&myInt2);
Console.WriteLine("myInt: {0}", myInt2);
}
```

If you would rather not force the caller to wrap the invocation within an unsafe context, you could update `Main()` with the `unsafe` keyword. In this case, the following code would compile:

```
unsafe static void Main(string[] args)
{
    int myInt2 = 5;
    SquareIntPtr(&myInt2);
    Console.WriteLine("myInt: {0}", myInt2);
}
```

If you run this `Main()` method, you will see the following output:

```
myInt: 25
```

Working with the * and & Operators

After you have established an unsafe context, you are then free to build pointers to data types using the `*` operator and obtain the address of what is being pointed to using the `&` operator. Unlike in C or C++, in C# the `*` operator is applied to the underlying type only, not as a prefix to each pointer variable name. For example, consider the following code, which illustrates both the correct and incorrect ways to declare pointers to integer variables:

```
// No! This is incorrect under C#!
int *pi, *pj;

// Yes! This is the way of C#.
int* pi, pj;
```

Consider the following unsafe method:

```
unsafe static void PrintValueAndAddress()
{
    int myInt;

    // Define an int pointer, and
    // assign it the address of myInt.
    int* ptrToMyInt = &myInt;

    // Assign value of myInt using pointer indirection.
    *ptrToMyInt = 123;

    // Print some stats.
    Console.WriteLine("Value of myInt {0}", myInt);
    Console.WriteLine("Address of myInt {0:X}", (int)&ptrToMyInt);
}
```

An Unsafe (and Safe) Swap Function

Of course, declaring pointers to local variables simply to assign their value (as in the previous example) is never required and not altogether useful. To illustrate a more practical example of unsafe code, assume you want to build a swap function using pointer arithmetic.

```
unsafe public static void UnsafeSwap(int* i, int* j)
{
    int temp = *i;
    *i = *j;
    *j = temp;
}
```

Very C-like, don't you think? However, given your work previously, you should be aware that you could write the following safe version of your swap algorithm using the C# `ref` keyword:

```
public static void SafeSwap(ref int i, ref int j)
{
    int temp = i;
    i = j;
    j = temp;
}
```

The functionality of each method is identical, thus reinforcing the point that direct pointer manipulation is not a mandatory task under C#. Here is the calling logic using a safe `Main()`, with an unsafe context:

```
static void Main(string[] args)
{
    Console.WriteLine("***** Calling method with unsafe code *****");

    // Values for swap.
    int i = 10, j = 20;

    // Swap values "safely."
    Console.WriteLine("\n***** Safe swap *****");
    Console.WriteLine("Values before safe swap: i = {0}, j = {1}", i, j);
    SafeSwap(ref i, ref j);
    Console.WriteLine("Values after safe swap: i = {0}, j = {1}", i, j);

    // Swap values "unsafely."
    Console.WriteLine("\n***** Unsafe swap *****");
    Console.WriteLine("Values before unsafe swap: i = {0}, j = {1}", i, j);
    unsafe { UnsafeSwap(&i, &j); }

    Console.WriteLine("Values after unsafe swap: i = {0}, j = {1}", i, j);
    Console.ReadLine();
}
```

Field Access via Pointers (the -> Operator)

Now assume you have defined a simple, safe `Point` structure, as follows:

```
struct Point
{
    public int x;
    public int y;

    public override string ToString()
    {
        return string.Format("{0}, {1}", x, y);
    }
}
```

If you declare a pointer to a `Point` type, you will need to make use of the pointer field-access operator (represented by `->`) to access its public members. As shown in Table 11-2, this is the unsafe version of the standard (safe) dot operator (`.`). In fact, using the pointer indirection operator (`*`), it is possible to dereference a pointer to (once again) apply the dot operator notation. Check out the unsafe method:

```
unsafe static void UsePointerToPoint()
{
    // Access members via pointer.
    Point point;
    Point* p = &point;
    p->x = 100;
    p->y = 200;
    Console.WriteLine(p->ToString());

    // Access members via pointer indirection.
    Point point2;
    Point* p2 = &point2;
    (*p2).x = 100;
    (*p2).y = 200;
    Console.WriteLine((*p2).ToString());
}
```

The `stackalloc` Keyword

In an unsafe context, you may need to declare a local variable that allocates memory directly from the call stack (and is, therefore, not subject to .NET garbage collection). To do so, C# provides the `stackalloc` keyword, which is the C# equivalent to the `_alloca` function of the C runtime library. Here is a simple example:

```
unsafe static void UnsafeStackAlloc()
{
    char* p = stackalloc char[256];
    for (int k = 0; k < 256; k++)
        p[k] = (char)k;
}
```

Pinning a Type via the fixed Keyword

As you saw in the previous example, allocating a chunk of memory within an unsafe context may be facilitated via the `stackalloc` keyword. By the very nature of this operation, the allocated memory is cleaned up as soon as the allocating method has returned (as the memory is acquired from the stack). However, assume a more complex example. During our examination of the `->` operator, you created a value type named `Point`. Like all value types, the allocated memory is popped off the stack once the executing scope has terminated. For the sake of argument, assume `Point` was instead defined as a *reference* type, like so:

```
class PointRef // <= Renamed and retyped.
{
    public int x;
    public int y;
    public override string ToString()
    {
        return string.Format("{0}, {1}", x, y);
    }
}
```

As you are aware, if the caller declares a variable of type `Point`, the memory is allocated on the garbage-collected heap. The burning question then becomes, “What if an unsafe context wants to interact with this object (or any object on the heap)?” Given that garbage collection can occur at any moment, imagine the problems encountered when accessing the members of `Point` at the very point in time such a sweep of the heap is underway. Theoretically, it is possible that the unsafe context is attempting to interact with a member that is no longer accessible or has been repositioned on the heap after surviving a generational sweep (which is an obvious problem).

To lock a reference type variable in memory from an unsafe context, C# provides the `fixed` keyword. The `fixed` statement sets a pointer to a managed type and “pins” that variable during the execution of the code. Without `fixed`, pointers to managed variables would be of little use, since garbage collection could relocate the variables unpredictably. (In fact, the C# compiler will not allow you to set a pointer to a managed variable except in a `fixed` statement.)

Thus, if you create a `PointRef` object and want to interact with its members, you must write the following code (or receive a compiler error):

```
unsafe public static void UseAndPinPoint()
{
    PointRef pt = new PointRef ();
    pt.x = 5;
    pt.y = 6;

    // Pin pt in place so it will not
    // be moved or GC-ed.
    fixed (int* p = &pt.x)
    {
        // Use int* variable here!
    }

    // pt is now unpinned, and ready to be GC-ed once
    // the method completes.
    Console.WriteLine ("Point is: {0}", pt);
}
```

In a nutshell, the `fixed` keyword allows you to build a statement that locks a reference variable in memory, such that its address remains constant for the duration of the statement (or scope block). Any time you interact with a reference type from within the context of unsafe code, pinning the reference is a must.

The sizeof Keyword

The final unsafe-centric C# keyword to consider is `sizeof`. As in C++, the C# `sizeof` keyword is used to obtain the size in bytes of an *intrinsic data type*, but not a custom type, unless within an unsafe context. For example, the following method does not need to be declared “unsafe” as all arguments to the `sizeof` keyword are intrinsic types:

```
static void UseSizeOfOperator()
{
    Console.WriteLine("The size of short is {0}.", sizeof(short));
    Console.WriteLine("The size of int is {0}.", sizeof(int));
    Console.WriteLine("The size of long is {0}.", sizeof(long));
}
```

However, if you want to get the size of your custom `Point` structure, you need to update this method as so (note the `unsafe` keyword has been added):

```
unsafe static void UseSizeOfOperator()
{
    ...
    Console.WriteLine("The size of Point is {0}.", sizeof(Point));
}
```

■ **Source Code** The `UnsafeCode` project can be found in the Chapter 11 subdirectory.

That wraps up the look at some of the more advanced features of the C# programming language. To make sure we are all on the same page here, I again must say that a majority of your .NET projects might never need to directly use these features (especially pointers). Nevertheless, as you will see in later chapters, some topics are quite useful, if not required, when working with the LINQ APIs, most notably extension methods and anonymous types.

Summary

The purpose of this chapter was to deepen your understanding of the C# programming language. First, you investigated various advanced type construction techniques (indexer methods, overloaded operators, and custom conversion routines).

Next, you examined the role of extension methods and anonymous types. As you’ll see in some detail in the next chapter, these features are useful when working with LINQ-centric APIs (though you can use them anywhere in your code, should they be useful). Recall that anonymous methods allow you to quickly model the “shape” of a type, while extension methods allow you to tack on new functionality to types, without the need to subclass.

You spent the remainder of this chapter examining a small set of lesser-known keywords (`sizeof`, `unsafe`, and so forth) and during the process learned how to work with raw pointer types. As stated throughout the examination of pointer types, the vast majority of your C# applications will never need to use them.

CHAPTER 12



LINQ to Objects

Regardless of the type of application you are creating using the .NET platform, your program will certainly need to access some form of data as it executes. To be sure, data can be found in numerous locations, including XML files, relational databases, in-memory collections, and primitive arrays. Historically speaking, based on the location of said data, programmers needed to make use of different and unrelated APIs. The Language Integrated Query (LINQ) technology set, introduced initially in .NET 3.5, provides a concise, symmetrical, and strongly typed manner to access a wide variety of data stores. In this chapter, you will begin your investigation of LINQ by focusing on LINQ to Objects.

Before you dive into LINQ to Objects proper, the first part of this chapter quickly reviews the key C# programming constructs that enable LINQ. As you work through this chapter, you will find that implicitly typed local variables, object initialization syntax, lambda expressions, extension methods, and anonymous types will be quite useful (if not occasionally mandatory).

After this supporting infrastructure is reviewed, the remainder of the chapter will introduce you to the LINQ programming model and its role in the .NET platform. Here, you will come to learn the role of query operators and query expressions, which allow you to define statements that will interrogate a data source to yield the requested result set. Along the way, you will build numerous LINQ examples that interact with data contained within arrays as well as various collection types (both generic and nongeneric) and understand the assemblies, namespaces, and types that represent the LINQ to Objects API.

■ **Note** The information in this chapter is the foundation for future chapters of the book that examine additional LINQ technologies, including LINQ to XML (Chapter 24), Parallel LINQ (Chapter 19), and LINQ to Entities (Chapter 23).

LINQ-Specific Programming Constructs

From a high level, LINQ can be understood as a strongly typed query language, embedded directly into the grammar of C#. Using LINQ, you can build any number of expressions that have a look and feel similar to that of a database SQL query. However, a LINQ query can be applied to any number of data stores, including stores that have nothing to do with a literal relational database.

■ **Note** Although LINQ queries look similar to SQL queries, the syntax is *not* identical. In fact, many LINQ queries seem to be the exact opposite format of a similar database query! If you attempt to map LINQ directly to SQL, you will surely become frustrated. To keep your sanity, I recommend you try your best to regard LINQ queries as unique statements, which just “happen to look” similar to SQL.

When LINQ was first introduced to the .NET platform in version 3.5, the C# and VB languages were each expanded with a large number of new programming constructs used to support the LINQ technology set. Specifically, the C# language uses the following core LINQ-centric features:

- Implicitly typed local variables
- Object/collection initialization syntax
- Lambda expressions
- Extension methods
- Anonymous types

These features have already been explored in detail within various chapters of the text. However, to get the ball rolling, let's quickly review each feature in turn, just to make sure we are all in the proper mind-set.

■ **Note** Because the following sections are reviews of material covered elsewhere in the book, I have not included a C# code project for this content.

Implicit Typing of Local Variables

In Chapter 3, you learned about the `var` keyword of C#. This keyword allows you to define a local variable without explicitly specifying the underlying data type. The variable, however, is strongly typed, as the compiler will determine the correct data type based on the initial assignment. Recall the following code example from Chapter 3:

```
static void DeclareImplicitVars()
{
    // Implicitly typed local variables.
    var myInt = 0;
    var myBool = true;
    var myString = "Time, marches on...";

    // Print out the underlying type.
    Console.WriteLine("myInt is a: {0}", myInt.GetType().Name);
    Console.WriteLine("myBool is a: {0}", myBool.GetType().Name);
    Console.WriteLine("myString is a: {0}", myString.GetType().Name);
}
```

This language feature is helpful, and often mandatory, when using LINQ. As you will see during this chapter, many LINQ queries will return a sequence of data types, which are not known until compile time. Given that the underlying data type is not known until the application is compiled, you obviously can't declare a variable explicitly!

Object and Collection Initialization Syntax

Chapter 5 explored the role of object initialization syntax, which allows you to create a class or structure variable and to set any number of its public properties in one fell swoop. The end result is a compact (yet still easy on the eyes) syntax that can be used to get your objects ready for use. Also recall from Chapter 9,

the C# language allows you to use a similar syntax to initialize collections of objects. Consider the following code snippet, which uses collection initialization syntax to fill a `List<T>` of `Rectangle` objects, each of which maintains two `Point` objects to represent an (x,y) position:

```
List<Rectangle> myListOfRects = new List<Rectangle>
{
    new Rectangle {TopLeft = new Point { X = 10, Y = 10 },
                  BottomRight = new Point { X = 200, Y = 200}},
    new Rectangle {TopLeft = new Point { X = 2, Y = 2 },
                  BottomRight = new Point { X = 100, Y = 100}},
    new Rectangle {TopLeft = new Point { X = 5, Y = 5 },
                  BottomRight = new Point { X = 90, Y = 75}}
};
```

While you are never required to use collection/object initialization syntax, doing so results in a more compact code base. Furthermore, this syntax, when combined with implicit typing of local variables, allows you to declare an anonymous type, which is useful when creating a LINQ projection. You'll learn about LINQ projections later in this chapter.

Lambda Expressions

The C# lambda operator (`=>`) was fully explored in Chapter 10. Recall that this operator allows you to build a lambda expression, which can be used any time you invoke a method that requires a strongly typed delegate as an argument. Lambdas greatly simplify how you work with .NET delegates, in that they reduce the amount of code you have to author by hand. Recall that a lambda expression can be broken down into the following usage:

```
( ArgumentsToProcess ) => { StatementsToProcessThem }
```

In Chapter 10, I walked you through how to interact with the `FindAll()` method of the generic `List<T>` class using three different approaches. After working with the raw `Predicate<T>` delegate and a C# anonymous method, you eventually arrived with the following (extremely concise) iteration that used the following lambda expression:

```
static void LambdaExpressionSyntax()
{
    // Make a list of integers.
    List<int> list = new List<int>();
    list.AddRange(new int[] { 20, 1, 4, 8, 9, 44 });

    // C# lambda expression.
    List<int> evenNumbers = list.FindAll(i => (i % 2) == 0);

    Console.WriteLine("Here are your even numbers:");
    foreach (int evenNumber in evenNumbers)
    {
        Console.WriteLine("{0}\t", evenNumber);
    }
    Console.WriteLine();
}
```

Lambdas will be useful when working with the underlying object model of LINQ. As you will soon find out, the C# LINQ query operators are simply a shorthand notation for calling true-blue methods on a class named `System.Linq.Enumerable`. These methods typically always require delegates (the `Func<>` delegate in particular) as parameters, which are used to process your data to yield the correct result set. Using lambdas, you can streamline your code and allow the compiler to infer the underlying delegate.

Extension Methods

C# extension methods allow you to tack on new functionality to existing classes without the need to subclass. As well, extension methods allow you to add new functionality to sealed classes and structures, which could never be subclassed in the first place. Recall from Chapter 11, when you author an extension method, the first parameter is qualified with the `this` keyword and marks the type being extended. Also recall that extension methods must always be defined within a static class and must, therefore, also be declared using the `static` keyword. Here's an example:

```
namespace MyExtensions
{
    static class ObjectExtensions
    {
        // Define an extension method to System.Object.
        public static void DisplayDefiningAssembly(this object obj)
        {
            Console.WriteLine("{0} lives here:\n\t->{1}\n", obj.GetType().Name,
                Assembly.GetAssembly(obj.GetType()));
        }
    }
}
```

To use this extension, an application must import the namespace defining the extension (and possibly add a reference to the external assembly). At this point, simply import the defining namespace and code away.

```
static void Main(string[] args)
{
    // Since everything extends System.Object, all classes and structures
    // can use this extension.
    int myInt = 12345678;
    myInt.DisplayDefiningAssembly();

    System.Data.DataSet d = new System.Data.DataSet();
    d.DisplayDefiningAssembly();
    Console.ReadLine();
}
```

When you are working with LINQ, you will seldom, if ever, be required to manually build your own extension methods. However, as you create LINQ query expressions, you will actually be making use of numerous extension methods already defined by Microsoft. In fact, each C# LINQ query operator is a shorthand notation for making a manual call on an underlying extension method, typically defined by the `System.Linq.Enumerable` utility class.

Anonymous Types

The final C# language feature I'd like to quickly review is that of anonymous types, which was explored in Chapter 11. This feature can be used to quickly model the “shape” of data by allowing the compiler to generate a new class definition at compile time, based on a supplied set of name-value pairs. Recall that this type will be composed using value-based semantics, and each virtual method of `System.Object` will be overridden accordingly. To define an anonymous type, declare an implicitly typed variable and specify the data's shape using object initialization syntax.

```
// Make an anonymous type that is composed of another.
var purchaseItem = new {
    TimeBought = DateTime.Now,
    ItemBought = new {Color = "Red", Make = "Saab", CurrentSpeed = 55},
    Price = 34.000};
```

LINQ makes frequent use of anonymous types when you want to project new forms of data on the fly. For example, assume you have a collection of `Person` objects and want to use LINQ to obtain information on the age and Social Security number of each. Using a LINQ projection, you can allow the compiler to generate a new anonymous type that contains your information.

Understanding the Role of LINQ

That wraps up the quick review of the C# language features that allow LINQ to work its magic. However, why have LINQ in the first place? Well, as software developers, it is hard to deny that the vast majority of our programming time is spent obtaining and manipulating data. When speaking of “data,” it is easy to immediately envision information contained within relational databases. However, another popular location for data is within XML documents or simple text files.

Data can be found in numerous places beyond these two common homes for information. For instance, say you have an array or generic `List<T>` type containing 300 integers and you want to obtain a subset that meets a given criterion (e.g., only the odd or even members in the container, only prime numbers, only nonrepeating numbers greater than 50). Or perhaps you are making use of the reflection APIs and need to obtain only metadata descriptions for each class deriving from a particular parent class within an array of `Types`. Indeed, data is *everywhere*.

Prior to .NET 3.5, interacting with a particular flavor of data required programmers to use very diverse APIs. Consider, for example, Table 12-1, which illustrates several common APIs used to access various types of data (I'm sure you can think of many other examples).

Table 12-1. Ways to Manipulate Various Types of Data

| The Data You Want | How to Obtain It |
|------------------------|---|
| Relational data | <code>System.Data.dll</code> , <code>System.Data.SqlClient.dll</code> , and so on |
| XML document data | <code>System.Xml.dll</code> |
| Metadata tables | The <code>System.Reflection</code> namespace |
| Collections of objects | <code>System.Array</code> and the <code>System.Collections/System.Collections.Generic</code> namespaces |

Of course, nothing is wrong with these approaches to data manipulation. In fact, you can (and will) certainly make direct use of ADO.NET, the XML namespaces, reflection services, and the various collection types. However, the basic problem is that each of these APIs is an island unto itself, which offers little in the way of integration. True, it is possible (for example) to save an ADO.NET DataSet as XML and then manipulate it via the `System.Xml` namespaces, but nonetheless, data manipulation remains rather asymmetrical.

The LINQ API is an attempt to provide a consistent, symmetrical manner in which programmers can obtain and manipulate “data” in the broad sense of the term. Using LINQ, you are able to create directly within the C# programming language constructs called *query expressions*. These query expressions are based on numerous query operators that have been intentionally designed to look and feel similar (but not quite identical) to a SQL expression.

The twist, however, is that a query expression can be used to interact with numerous types of data—even data that has nothing to do with a relational database. Strictly speaking, “LINQ” is the term used to describe this overall approach to data access. However, based on where you are applying your LINQ queries, you will encounter various terms, such as the following:

- *LINQ to Objects*: This term refers to the act of applying LINQ queries to arrays and collections.
- *LINQ to XML*: This term refers to the act of using LINQ to manipulate and query XML documents.
- *LINQ to DataSet*: This term refers to the act of applying LINQ queries to ADO.NET DataSet objects.
- *LINQ to Entities*: This aspect of LINQ allows you to make use of LINQ queries within the ADO.NET Entity Framework (EF) API.
- *Parallel LINQ* (aka *PLINQ*): This allows for parallel processing of data returned from a LINQ query.

Today, LINQ is an integral part of the .NET base class libraries, managed languages, and Visual Studio itself.

LINQ Expressions Are Strongly Typed

It is also important to point out that a LINQ query expression (unlike a traditional SQL statement) is *strongly typed*. Therefore, the C# compiler will keep you honest and make sure that these expressions are syntactically well-formed. Tools such as Visual Studio can use metadata for useful features such as IntelliSense, autocompletion, and so forth.

The Core LINQ Assemblies

As mentioned in Chapter 2, the New Project dialog of Visual Studio has the option of selecting which version of the .NET platform you want to compile against. When you opt to compile against .NET 3.5 or higher, each of the project templates will automatically reference the key LINQ assemblies, which can be viewed using the Solution Explorer. Table 12-2 documents the role of the key LINQ assemblies. However, you will encounter additional LINQ libraries over the remainder of this book.

Table 12-2. Core LINQ-Centric Assemblies

| Assembly | Meaning in Life |
|-----------------------------------|--|
| System.Core.dll | Defines the types that represent the core LINQ API. This is the one assembly you must have access to if you want to use any LINQ API, including LINQ to Objects. |
| System.Data.DataSetExtensions.dll | Defines a handful of types to integrate ADO.NET types into the LINQ programming paradigm (LINQ to DataSet). |
| System.Xml.Linq.dll | Provides functionality for using LINQ with XML document data (LINQ to XML). |

To work with LINQ to Objects, you must make sure that every C# code file that contains LINQ queries imports the `System.Linq` namespace (primarily defined within `System.Core.dll`). If you do not do so, you will run into a number of problems. As a good rule of thumb, if you see a compiler error looking similar to this:

```
Error 1 Could not find an implementation of the query pattern for source type 'int[]'.
'Where' not found. Are you missing a reference to 'System.Core.dll' or a using directive
for 'System.Linq'?
```

the chances are extremely good that your C# file does not have the following using directive:

```
using System.Linq;
```

Applying LINQ Queries to Primitive Arrays

To begin examining LINQ to Objects, let's build an application that will apply LINQ queries to various array objects. Create a Console Application project named `LinqOverArray`, and define a static helper method within the `Program` class named `QueryOverStrings()`. In this method, create a `string` array containing six or so items of your liking (here I listed a batch of video games in my library). Make sure to have at least two entries that contain numerical values and a few that have embedded spaces.

```
static void QueryOverStrings()
{
    // Assume we have an array of strings.
    string[] currentVideoGames = {"Morrowind", "Uncharted 2",
                                  "Fallout 3", "Daxter", "System Shock 2"};
}
```

Now, update `Main()` to invoke `QueryOverStrings()`.

```
static void Main(string[] args)
{
    Console.WriteLine("***** Fun with LINQ to Objects *****\n");
    QueryOverStrings();
    Console.ReadLine();
}
```

When you have any array of data, it is common to extract a subset of items based on a given requirement. Maybe you want to obtain only the subitems that contain a number (e.g., System Shock 2, Uncharted 2, and Fallout 3), have more or less than some number of characters, or don't contain embedded spaces (e.g., Morrowind or Dexter). While you could certainly perform such tasks using members of the `System.Array` type and a bit of elbow grease, LINQ query expressions can greatly simplify the process.

Going on the assumption that you want to obtain from the array only items that contain an embedded blank space and you want these items listed in alphabetical order, you could build the following LINQ query expression:

```
static void QueryOverStrings()
{
    // Assume we have an array of strings.
    string[] currentVideoGames = {"Morrowind", "Uncharted 2",
        "Fallout 3", "Daxter", "System Shock 2"};

    // Build a query expression to find the items in the array
    // that have an embedded space.
    IEnumerable<string> subset = from g in currentVideoGames
        where g.Contains(" ") orderby g select g;

    // Print out the results.
    foreach (string s in subset)
        Console.WriteLine("Item: {0}", s);
}
```

Notice that the query expression created here makes use of the `from`, `in`, `where`, `orderby`, and `select` LINQ query operators. You will dig into the formalities of query expression syntax later in this chapter. However, even now you should be able to read this statement roughly as “Give me the items inside of `currentVideoGames` that contain a space, ordered alphabetically.”

Here, each item that matches the search criteria has been given the name `g` (as in “game”); however, any valid C# variable name would do:

```
IEnumerable<string> subset = from game in currentVideoGames
    where game.Contains(" ") orderby
    game select game;
```

Notice that the returned sequence is held in a variable named `subset`, typed as a type that implements the generic version of `IEnumerable<T>`, where `T` is of type `System.String` (after all, you are querying an array of strings). After you obtain the result set, you then simply print out each item using a standard `foreach` construct. If you run your application, you will find the following output:

```
***** Fun with LINQ to Objects *****
```

```
Item: Fallout 3
Item: System Shock 2
Item: Uncharted 2
```

Once Again, Without LINQ

To be sure, LINQ is never mandatory. If you so choose, you could have found the same result set by forgoing LINQ altogether and making use of programming primitives such as `if` statements and `for` loops. Here is a method that yields the same result as the `QueryOverStrings()` method but in a much more verbose manner:

```
static void QueryOverStringsLongHand()
{
    // Assume we have an array of strings.
    string[] currentVideoGames = {"Morrowind", "Uncharted 2",
        "Fallout 3", "Daxter", "System Shock 2"};

    string[] gamesWithSpaces = new string[5];

    for (int i = 0; i < currentVideoGames.Length; i++)
    {
        if (currentVideoGames[i].Contains(" "))
            gamesWithSpaces[i] = currentVideoGames[i];
    }

    // Now sort them.
    Array.Sort(gamesWithSpaces);

    // Print out the results.
    foreach (string s in gamesWithSpaces)
    {
        if (s != null)
            Console.WriteLine("Item: {0}", s);
    }
    Console.WriteLine();
}
```

While I am sure you can think of ways to tweak the previous method, the fact remains that LINQ queries can be used to radically simplify the process of extracting new subsets of data from a source. Rather than building nested loops, complex `if/else` logic, temporary data types, and so on, the C# compiler will perform the dirty work on your behalf, once you create a fitting LINQ query.

Reflecting over a LINQ Result Set

Now, assume the `Program` class defines an additional helper function named `ReflectOverQueryResults()` that will print out various details of the LINQ result set (note the parameter is a `System.Object`, to account for multiple types of result sets).

```
static void ReflectOverQueryResults(object resultSet)
{
    Console.WriteLine("***** Info about your query *****");
    Console.WriteLine("resultSet is of type: {0}", resultSet.GetType().Name);
    Console.WriteLine("resultSet location: {0}",
        resultSet.GetType().Assembly.GetName().Name);
}
```

Assuming you have called this method within `QueryOverStrings()` directly after printing out the obtained subset, if you run the application, you will see the subset is really an instance of the generic `OrderedEnumerable<TElement, TKey>` type (represented in terms of CIL code as `OrderedEnumerable`2`), which is an internal abstract type residing in the `System.Core.dll` assembly.

```
***** Info about your query *****
resultSet is of type: OrderedEnumerable`2
resultSet location: System.Core
```

■ **Note** Many of the types that represent a LINQ result are hidden by the Visual Studio object browser. These are low-level types not intended for direct use in your applications.

LINQ and Implicitly Typed Local Variables

While the current sample program makes it relatively easy to determine that the result set can be captured as an enumeration of string object (e.g., `IEnumerable<string>`), I would guess that it is *not* clear that subset is really of type `OrderedEnumerable<TElement, TKey>`.

Given that LINQ result sets can be represented using a good number of types in various LINQ-centric namespaces, it would be tedious to define the proper type to hold a result set, because in many cases the underlying type may not be obvious or even directly accessible from your code base (and as you will see, in some cases the type is generated at compile time).

To further accentuate this point, consider the following additional helper method defined within the `Program` class (which I assume you will invoke from within the `Main()` method):

```
static void QueryOverInts()
{
    int[] numbers = {10, 20, 30, 40, 1, 2, 3, 8};

    // Print only items less than 10.
    IEnumerable<int> subset = from i in numbers where i < 10 select i;

    foreach (int i in subset)
        Console.WriteLine("Item: {0}", i);
    ReflectOverQueryResults(subset);
}
```

In this case, the `subset` variable is a completely different underlying type. This time, the type implementing the `IEnumerable<int>` interface is a low-level class named `WhereArrayIterator<T>`.

```
Item: 1
Item: 2
Item: 3
Item: 8

***** Info about your query *****
resultSet is of type: WhereArrayIterator`1
resultSet location: System.Core
```

Given that the exact underlying type of a LINQ query is certainly not obvious, these first examples have represented the query results as an `IEnumerable<T>` variable, where `T` is the type of data in the returned sequence (string, int, etc.). However, this is still rather cumbersome. To add insult to injury, given that `IEnumerable<T>` extends the nongeneric `IEnumerable` interface, it would also be permissible to capture the result of a LINQ query as follows:

```
System.Collections.IEnumerable subset =
    from i in numbers where i < 10 select i;
```

Thankfully, implicit typing cleans things up considerably when working with LINQ queries.

```
static void QueryOverInts()
{
    int[] numbers = {10, 20, 30, 40, 1, 2, 3, 8};

    // Use implicit typing here...
    var subset = from i in numbers where i < 10 select i;

    // ...and here.
    foreach (var i in subset)
        Console.WriteLine("Item: {0} ", i);
    ReflectOverQueryResults(subset);
}
```

As a rule of thumb, you will always want to make use of implicit typing when capturing the results of a LINQ query. Just remember, however, that (in a vast majority of cases) the *real* return value is a type implementing the generic `IEnumerable<T>` interface.

Exactly what this type is under the covers (`OrderedEnumerable<TElement, TKey>`, `WhereArrayIterator<T>`, etc.) is irrelevant and not necessary to discover. As seen in the previous code example, you can simply use the `var` keyword within a `foreach` construct to iterate over the fetched data.

LINQ and Extension Methods

Although the current example does not have you author any extension methods directly, you are in fact using them seamlessly in the background. LINQ query expressions can be used to iterate over data containers that implement the generic `IEnumerable<T>` interface. However, the .NET `System.Array` class type (used to represent the array of strings and array of integers) does *not* implement this contract.

```
// The System.Array type does not seem to implement the correct
// infrastructure for query expressions!
public abstract class Array : ICloneable, IList, ICollection,
    IEnumerable, IStructuralComparable, IStructuralEquatable
{
    ...
}
```

While `System.Array` does not directly implement the `IEnumerable<T>` interface, it indirectly gains the required functionality of this type (as well as many other LINQ-centric members) via the static `System.Linq.Enumerable` class type.

This utility class defines a good number of generic extension methods (such as `Aggregate<T>()`, `First<T>()`, `Max<T>()`, etc.), which `System.Array` (and other types) acquire in the background. Thus, if you apply the dot operator on the `currentVideoGames` local variable, you will find a good number of members *not* found within the formal definition of `System.Array` (see Figure 12-1).

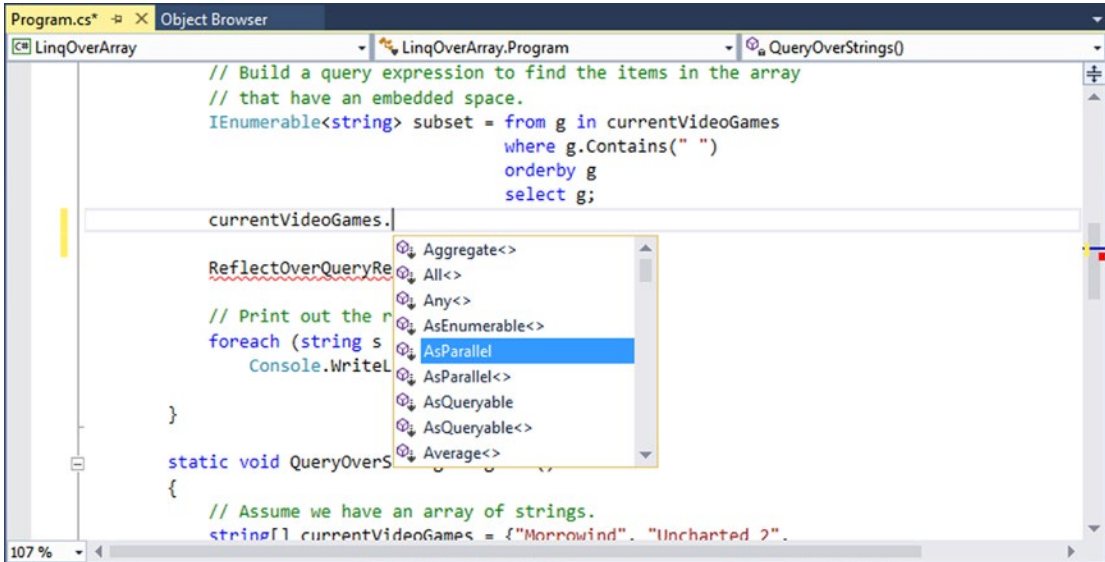

Figure 12-1. The `System.Array` type has been extended with members of `System.Linq.Enumerable`

The Role of Deferred Execution

Another important point regarding LINQ query expressions is that they are not actually evaluated until you iterate over the sequence. Formally speaking, this is termed *deferred execution*. The benefit of this approach is that you are able to apply the same LINQ query multiple times to the same container and rest assured you are obtaining the latest and greatest results. Consider the following update to the `QueryOverInts()` method:

```

static void QueryOverInts()
{
    int[] numbers = { 10, 20, 30, 40, 1, 2, 3, 8 };

    // Get numbers less than ten.
    var subset = from i in numbers where i < 10 select i;

    // LINQ statement evaluated here!
    foreach (var i in subset)
        Console.WriteLine("{0} < 10", i);
    Console.WriteLine();
    // Change some data in the array.
    numbers[0] = 4;
}

```

```

// Evaluated again!
foreach (var j in subset)
    Console.WriteLine("{0} < 10", j);

Console.WriteLine();
ReflectOverQueryResults(subset);
}

```

If you were to execute the program yet again, you would find the following output. Notice that the second time you iterate over the requested sequence, you find an additional member, as you set the first item in the array to be a value less than ten.

```

1 < 10
2 < 10
3 < 10
8 < 10

4 < 10
1 < 10
2 < 10
3 < 10
8 < 10

```

One useful aspect of Visual Studio is that if you set a breakpoint before the evaluation of a LINQ query, you are able to view the contents during a debugging session. Simply locate your mouse cursor above the LINQ result set variable (subset in Figure 12-2). When you do, you will be given the option of evaluating the query at that time by expanding the Results View option.

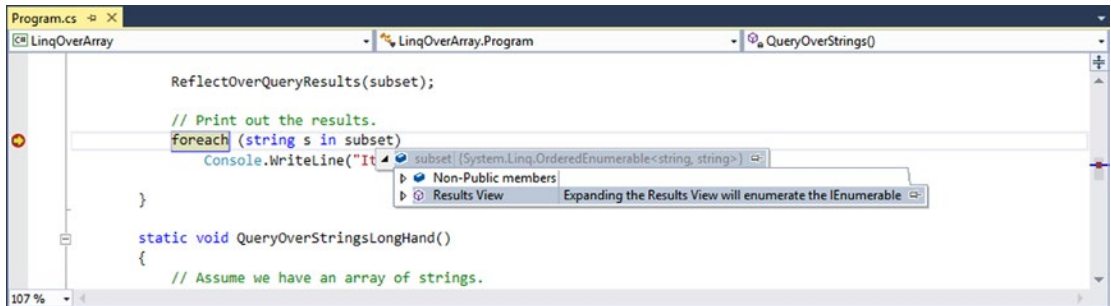

Figure 12-2. Debugging LINQ expressions

The Role of Immediate Execution

When you need to evaluate a LINQ expression from outside the confines of `foreach` logic, you are able to call any number of extension methods defined by the `Enumerable` type such as `ToArray<T>()`, `ToDictionary<TSource, TKey>()`, and `ToList<T>()`. These methods will cause a LINQ query to execute at the exact moment you call them, to obtain a snapshot of the data. After you have done so, the snapshot of data may be independently manipulated.

```

static void ImmediateExecution()
{
    int[] numbers = { 10, 20, 30, 40, 1, 2, 3, 8 };

    // Get data RIGHT NOW as int[].
    int[] subsetAsIntArray =
        (from i in numbers where i < 10 select i).ToArray<int>();

    // Get data RIGHT NOW as List<int>.
    List<int> subsetAsListOfInts =
        (from i in numbers where i < 10 select i).ToList<int>();
}

```

Notice that the entire LINQ expression is wrapped within parentheses to cast it into the correct underlying type (whatever that might be) in order to call the extension methods of `Enumerable`.

Also recall from Chapter 9 that when the C# compiler can unambiguously determine the type parameter of a generic, you are not required to specify the type parameter. Thus, you could also call `ToArray<T>()` (or `ToList<T>()` for that matter) as follows:

```

int[] subsetAsIntArray =
    (from i in numbers where i < 10 select i).ToArray();

```

The usefulness of immediate execution is obvious when you need to return the results of a LINQ query to an external caller. And, as luck would have it, this happens to be the next topic of this chapter.

■ **Source Code** The `LinqOverArray` project can be found in the Chapter 12 subdirectory.

Returning the Result of a LINQ Query

It is possible to define a field within a class (or structure) whose value is the result of a LINQ query. To do so, however, you cannot make use of implicit typing (as the `var` keyword cannot be used for fields), and the target of the LINQ query cannot be instance-level data; therefore, it must be static. Given these limitations, you will seldom need to author code like the following:

```

class LINQBasedFieldsAreClunky
{
    private static string[] currentVideoGames = {"Morrowind", "Uncharted 2",
        "Fallout 3", "Daxter", "System Shock 2"};

    // Can't use implicit typing here! Must know type of subset!
    private IEnumerable<string> subset = from g in currentVideoGames
        where g.Contains(" ") orderby g select g;

    public void PrintGames()
    {
        foreach (var item in subset)
        {
            Console.WriteLine(item);
        }
    }
}

```

More often than not, LINQ queries are defined within the scope of a method or property. Moreover, to simplify your programming, the variable used to hold the result set will be stored in an implicitly typed local variable using the `var` keyword. Now, recall from Chapter 3 that implicitly typed variables cannot be used to define parameters, return values, or fields of a class or structure.

Given this point, you might wonder exactly how you could return a query result to an external caller. The answer is, it depends. If you have a result set consisting of strongly typed data, such as an array of strings or a `List<T>` of Cars, you could abandon the use of the `var` keyword and use a proper `IEnumerable<T>` or `IEnumerable` type (again, as `IEnumerable<T>` extends `IEnumerable`). Consider the following example for a new Console Application named `LinqRetVal`:

```
class Program
{
    static void Main(string[] args)
    {
        Console.WriteLine("***** LINQ Return Values *****\n");
        IEnumerable<string> subset = GetStringSubset();

        foreach (string item in subset)
        {
            Console.WriteLine(item);
        }

        Console.ReadLine();
    }
    static IEnumerable<string> GetStringSubset()
    {
        string[] colors = {"Light Red", "Green",
            "Yellow", "Dark Red", "Red", "Purple"};

        // Note subset is an IEnumerable<string>-compatible object.
        IEnumerable<string> theRedColors = from c in colors
            where c.Contains("Red") select c;

        return theRedColors;
    }
}
```

The results are as expected:

```
Light Red
Dark Red
Red
```

Returning LINQ Results via Immediate Execution

This example works as expected, only because the return value of the `GetStringSubset()` and the LINQ query within this method has been strongly typed. If you used the `var` keyword to define the `subset` variable, it would be permissible to return the value *only* if the method is still prototyped to return `IEnumerable<string>` (and if the implicitly typed local variable is in fact compatible with the specified return type).

Because it is a bit inconvenient to operate on `IEnumerable<T>`, you could make use of immediate execution. For example, rather than returning `IEnumerable<string>`, you could simply return a `string[]`, provided that you transform the sequence to a strongly typed array. Consider this new method of the `Program` class, which does this very thing:

```
static string[] GetStringSubsetAsArray()
{
    string[] colors = {"Light Red", "Green",
        "Yellow", "Dark Red", "Red", "Purple"};

    var theRedColors = from c in colors
        where c.Contains("Red") select c;

    // Map results into an array.
    return theRedColors.ToArray();
}
```

With this, the caller can be blissfully unaware that their result came from a LINQ query and simply work with the array of strings as expected. Here's an example:

```
foreach (string item in GetStringSubsetAsArray())
{
    Console.WriteLine(item);
}
```

Immediate execution is also critical when attempting to return to the caller the results of a LINQ projection. You'll examine this topic a bit later in the chapter. Next up, let's look at how to apply LINQ queries to generic and nongeneric collection objects.

■ **Source Code** The `LinqRetValValues` project can be found in the [Chapter 12](#) subdirectory.

Applying LINQ Queries to Collection Objects

Beyond pulling results from a simple array of data, LINQ query expressions can also manipulate data within members of the `System.Collections.Generic` namespace, such as the `List<T>` type. Create a new Console Application project named `LinqOverCollections`, and define a basic `Car` class that maintains a current speed, color, make, and pet name, as shown in the following code:

```
class Car
{
    public string PetName {get; set;} = "";
    public string Color {get; set;} = "";
    public int Speed {get; set;}
    public string Make {get; set;} = "";
}
```

Now, within your `Main()` method, define a local `List<T>` variable of type `Car`, and make use of object initialization syntax to fill the list with a handful of new `Car` objects.

```
static void Main(string[] args)
{
    Console.WriteLine("***** LINQ over Generic Collections *****\n");

    // Make a List<> of Car objects.
    List<Car> myCars = new List<Car>() {
        new Car{ PetName = "Henry", Color = "Silver", Speed = 100, Make = "BMW"},
        new Car{ PetName = "Daisy", Color = "Tan", Speed = 90, Make = "BMW"},
        new Car{ PetName = "Mary", Color = "Black", Speed = 55, Make = "VW"},
        new Car{ PetName = "Clunker", Color = "Rust", Speed = 5, Make = "Yugo"},
        new Car{ PetName = "Melvin", Color = "White", Speed = 43, Make = "Ford"}
    };

    Console.ReadLine();
}
```

Accessing Contained Subobjects

Applying a LINQ query to a generic container is no different from doing so with a simple array, as LINQ to Objects can be used on any type implementing `IEnumerable<T>`. This time, your goal is to build a query expression to select only the `Car` objects within the `myCars` list, where the speed is greater than 55.

After you get the subset, you will print out the name of each `Car` object by calling the `PetName` property. Assume you have the following helper method (taking a `List<Car>` parameter), which is called from within `Main()`:

```
static void GetFastCars(List<Car> myCars)
{
    // Find all Car objects in the List<>, where the Speed is
    // greater than 55.
    var fastCars = from c in myCars where c.Speed > 55 select c;

    foreach (var car in fastCars)
    {
        Console.WriteLine("{0} is going too fast!", car.PetName);
    }
}
```

Notice that your query expression is grabbing only those items from the `List<T>` where the `Speed` property is greater than 55. If you run the application, you will find that `Henry` and `Daisy` are the only two items that match the search criteria.

If you want to build a more complex query, you might want to find only the `BMW`s that have a `Speed` value above 90. To do so, simply build a compound Boolean statement using the C# `&&` operator.

```

static void GetFastBMWs(List<Car> myCars)
{
    // Find the fast BMWs!
    var fastCars = from c in myCars where c.Speed > 90 && c.Make == "BMW" select c;
    foreach (var car in fastCars)
    {
        Console.WriteLine("{0} is going too fast!", car.PetName);
    }
}

```

In this case, the only pet name printed out is Henry.

Applying LINQ Queries to Nongeneric Collections

Recall that the query operators of LINQ are designed to work with any type implementing `IEnumerable<T>` (either directly or via extension methods). Given that `System.Array` has been provided with such necessary infrastructure, it might surprise you that the legacy (nongeneric) containers within `System.Collections` have not. Thankfully, it is still possible to iterate over data contained within nongeneric collections using the generic `Enumerable.Of<T>()` extension method.

When calling `Of<T>()` from a nongeneric collection object (such as the `ArrayList`), simply specify the type of item within the container to extract a compatible `IEnumerable<T>` object. In code, you can store this data point using an implicitly typed variable.

Consider the following new method, which fills an `ArrayList` with a set of `Car` objects (be sure to import the `System.Collections` namespace into your `Program.cs` file):

```

static void LINQOverArrayList()
{
    Console.WriteLine("***** LINQ over ArrayList *****");

    // Here is a nongeneric collection of cars.
    ArrayList myCars = new ArrayList() {
        new Car{ PetName = "Henry", Color = "Silver", Speed = 100, Make = "BMW"},
        new Car{ PetName = "Daisy", Color = "Tan", Speed = 90, Make = "BMW"},
        new Car{ PetName = "Mary", Color = "Black", Speed = 55, Make = "VW"},
        new Car{ PetName = "Clunker", Color = "Rust", Speed = 5, Make = "Yugo"},
        new Car{ PetName = "Melvin", Color = "White", Speed = 43, Make = "Ford"}
    };

    // Transform ArrayList into an IEnumerable<T>-compatible type.
    var myCarsEnum = myCars.Of<Car>();

    // Create a query expression targeting the compatible type.
    var fastCars = from c in myCarsEnum where c.Speed > 55 select c;

    foreach (var car in fastCars)
    {
        Console.WriteLine("{0} is going too fast!", car.PetName);
    }
}

```

Similar to the previous examples, this method, when called from `Main()`, will display only the names Henry and Daisy, based on the format of the LINQ query.

Filtering Data Using `OfType<T>()`

As you know, nongeneric types are capable of containing any combination of items, as the members of these containers (again, such as the `ArrayList`) are prototyped to receive `System.Objects`. For example, assume an `ArrayList` contains a variety of items, only a subset of which are numerical. If you want to obtain a subset that contains only numerical data, you can do so using `OfType<T>()` since it filters out each element whose type is different from the given type during the iterations.

```
static void OfTypeAsFilterer()
{
    // Extract the ints from the ArrayList.
    ArrayList myStuff = new ArrayList();
    myStuff.AddRange(new object[] { 10, 400, 8, false, new Car(), "string data" });
    var myInts = myStuff.OfType<int>();

    // Prints out 10, 400, and 8.
    foreach (int i in myInts)
    {
        Console.WriteLine("Int value: {0}", i);
    }
}
```

At this point, you have had a chance to apply LINQ queries to arrays, generic collections, and nongeneric collections. These containers held both C# primitive types (integers, string data) as well as custom classes. The next task is to learn about many additional LINQ operators that can be used to build more complex and useful queries.

■ **Source Code** The `LinqOverCollections` project can be found in the [Chapter 12](#) subdirectory.

Investigating the C# LINQ Query Operators

C# defines a good number of query operators out of the box. [Table 12-3](#) documents some of the more commonly used query operators.

■ **Note** The .NET Framework SDK documentation provides full details regarding each of the C# LINQ operators. Look up the topic “LINQ General Programming Guide” for more information.

In addition to the partial list of operators shown in [Table 12-3](#), the `System.Linq.Enumerable` class provides a set of methods that do not have a direct C# query operator shorthand notation but are instead exposed as extension methods. These generic methods can be called to transform a result set in various manners (`Reverse<>()`, `ToArray<>()`, `ToList<>()`, etc.). Some are used to extract singletons from a result set, others perform various set operations (`Distinct<>()`, `Union<>()`, `Intersect<>()`, etc.), and still others aggregate results (`Count<>()`, `Sum<>()`, `Min<>()`, `Max<>()`, etc.).

Table 12-3. Common LINQ Query Operators

| Query Operators | Meaning in Life |
|--------------------------------|---|
| from, in | Used to define the backbone for any LINQ expression, which allows you to extract a subset of data from a fitting container. |
| where | Used to define a restriction for which items to extract from a container. |
| select | Used to select a sequence from the container. |
| join, on, equals, into | Performs joins based on specified key. Remember, these “joins” do not need to have anything to do with data in a relational database. |
| orderby, ascending, descending | Allows the resulting subset to be ordered in ascending or descending order. |
| group, by | Yields a subset with data grouped by a specified value. |

To begin digging into more intricate LINQ queries, create a new Console Application project named `FunWithLinqExpressions`. Next, you need to define an array or collection of some sample data. For this project, you will make an array of `ProductInfo` objects, defined in the following code:

```
class ProductInfo
{
    public string Name {get; set;} = "";
    public string Description {get; set;} = "";
    public int NumberInStock {get; set;} = 0;

    public override string ToString()
    {
        return string.Format("Name={0}, Description={1}, Number in Stock={2}",
            Name, Description, NumberInStock);
    }
}
```

Now populate an array with a batch of `ProductInfo` objects within your `Main()` method.

```
static void Main(string[] args)
{
    Console.WriteLine("***** Fun with Query Expressions *****\n");

    // This array will be the basis of our testing...
    ProductInfo[] itemsInStock = new[] {
        new ProductInfo{ Name = "Mac's Coffee",
            Description = "Coffee with TEETH",
            NumberInStock = 24},
        new ProductInfo{ Name = "Milk Maid Milk",
            Description = "Milk cow's love",
            NumberInStock = 100},
        new ProductInfo{ Name = "Pure Silk Tofu",
            Description = "Bland as Possible",
            NumberInStock = 120},
    }
```

```

new ProductInfo{ Name = "Cruchy Pops",
                Description = "Cheezy, peppery goodness",
                NumberInStock = 2},
new ProductInfo{ Name = "RipOff Water",
                Description = "From the tap to your wallet",
                NumberInStock = 100},
new ProductInfo{ Name = "Classic Valpo Pizza",
                Description = "Everyone loves pizza!",
                NumberInStock = 73}
};

// We will call various methods here!
Console.ReadLine();
}

```

Basic Selection Syntax

Because the syntactical correctness of a LINQ query expression is validated at compile time, you need to remember that the ordering of these operators is critical. In the simplest terms, every LINQ query expression is built using the `from`, `in`, and `select` operators. Here is the general template to follow:

```
var result = from matchingItem in container select matchingItem;
```

The item after the `from` operator represents an item that matches the LINQ query criteria, which can be named anything you choose. The item after the `in` operator represents the data container to search (an array, collection, XML document, etc.).

Here is a simple query, doing nothing more than selecting every item in the container (similar in behavior to a database `Select * SQL` statement). Consider the following:

```

static void SelectEverything(ProductInfo[] products)
{
    // Get everything!
    Console.WriteLine("All product details:");
    var allProducts = from p in products select p;

    foreach (var prod in allProducts)
    {
        Console.WriteLine(prod.ToString());
    }
}

```

To be honest, this query expression is not entirely useful, given that your subset is identical to that of the data in the incoming parameter. If you want, you could extract only the `Name` values of each car using the following selection syntax:

```

static void ListProductNames(ProductInfo[] products)
{
    // Now get only the names of the products.
    Console.WriteLine("Only product names:");
    var names = from p in products select p.Name;
}

```

```

foreach (var n in names)
{
    Console.WriteLine("Name: {0}", n);
}
}

```

Obtaining Subsets of Data

To obtain a specific subset from a container, you can use the where operator. When doing so, the general template now becomes the following code:

```
var result = from item in container where BooleanExpression select item;
```

Notice that the where operator expects an expression that resolves to a Boolean. For example, to extract from the `ProductInfo[]` argument only the items that have more than 25 items on hand, you could author the following code:

```

static void GetOverstock(ProductInfo[] products)
{
    Console.WriteLine("The overstock items!");

    // Get only the items where we have more than
    // 25 in stock.
    var overstock = from p in products where p.NumberInStock > 25 select p;

    foreach (ProductInfo c in overstock)
    {
        Console.WriteLine(c.ToString());
    }
}

```

As shown earlier in this chapter, when you are building a where clause, it is permissible to make use of any valid C# operators to build complex expressions. For example, recall the query that extracts out only the BMWs going at least 100 mph:

```

// Get BMWs going at least 100 mph.
var onlyFastBMWs = from c in myCars
                  where c.Make == "BMW" && c.Speed >= 100 select c;
foreach (Car c in onlyFastBMWs)
{
    Console.WriteLine("{0} is going {1} MPH", c.PetName, c.Speed);
}

```

Projecting New Data Types

It is also possible to project new forms of data from an existing data source. Let's assume you want to take the incoming `ProductInfo[]` parameter and obtain a result set that accounts only for the name and description of each item. To do so, you can define a select statement that dynamically yields a new anonymous type.

```

static void GetNamesAndDescriptions(ProductInfo[] products)
{
    Console.WriteLine("Names and Descriptions:");
    var nameDesc = from p in products select new { p.Name, p.Description };

    foreach (var item in nameDesc)
    {
        // Could also use Name and Description properties directly.
        Console.WriteLine(item.ToString());
    }
}

```

Always remember that when you have a LINQ query that makes use of a projection, you have no way of knowing the underlying data type, as this is determined at compile time. In these cases, the `var` keyword is mandatory. As well, recall that you cannot create methods with implicitly typed return values. Therefore, the following method would not compile:

```

static var GetProjectedSubset(ProductInfo[] products)
{
    var nameDesc = from p in products select new { p.Name, p.Description };
    return nameDesc; // Nope!
}

```

When you need to return projected data to a caller, one approach is to transform the query result into a `.NET System.Array` object using the `ToArray()` extension method. Thus, if you were to update your query expression as follows:

```

// Return value is now an Array.
static Array GetProjectedSubset(ProductInfo[] products)
{
    var nameDesc = from p in products select new { p.Name, p.Description };

    // Map set of anonymous objects to an Array object.
    return nameDesc.ToArray();
}

```

you could invoke and process the data from `Main()` as follows:

```

Array objs = GetProjectedSubset(itemsInStock);
foreach (object o in objs)
{
    Console.WriteLine(o); // Calls ToString() on each anonymous object.
}

```

Note that you must use a literal `System.Array` object and cannot make use of the C# array declaration syntax, given that you don't know the underlying type of type because you are operating on a compiler-generated anonymous class! Also note that you are not specifying the type parameter to the generic `ToArray<T>()` method, as you once again don't know the underlying data type until compile time, which is too late for your purposes.

The obvious problem is that you lose any strong typing, as each item in the `Array` object is assumed to be of type `Object`. Nevertheless, when you need to return a LINQ result set that is the result of a projection operation, transforming the data into an `Array` type (or another suitable container via other members of the `Enumerable` type) is mandatory.

Obtaining Counts Using Enumerable

When you are projecting new batches of data, you may need to discover exactly how many items have been returned into the sequence. Any time you need to determine the number of items returned from a LINQ query expression, simply use the `Count()` extension method of the `Enumerable` class. For example, the following method will find all `string` objects in a local array that have a length greater than six characters:

```
static void GetCountFromQuery()
{
    string[] currentVideoGames = {"Morrowind", "Uncharted 2",
                                   "Fallout 3", "Daxter", "System Shock 2"};

    // Get count from the query.
    int numb =
        (from g in currentVideoGames where g.Length > 6 select g).Count();

    // Print out the number of items.
    Console.WriteLine("{0} items honor the LINQ query.", numb);
}
```

Reversing Result Sets

You can reverse the items within a result set quite simply using the `Reverse<>()` extension method of the `Enumerable` class. For example, the following method selects all items from the incoming `ProductInfo[]` parameter, in reverse:

```
static void ReverseEverything(ProductInfo[] products)
{
    Console.WriteLine("Product in reverse:");
    var allProducts = from p in products select p;
    foreach (var prod in allProducts.Reverse())
    {
        Console.WriteLine(prod.ToString());
    }
}
```

Sorting Expressions

As you have seen over this chapter's initial examples, a query expression can take an `orderby` operator to sort items in the subset by a specific value. By default, the order will be ascending; thus, ordering by a string would be alphabetical, ordering by numerical data would be lowest to highest, and so forth. If you need to view the results in a descending order, simply include the descending operator. Ponder the following method:

```
static void AlphabetizeProductNames(ProductInfo[] products)
{
    // Get names of products, alphabetized.
    var subset = from p in products orderby p.Name select p;

    Console.WriteLine("Ordered by Name:");
    foreach (var p in subset)
    {
        Console.WriteLine(p.ToString());
    }
}
```

Although ascending order is the default, you are able to make your intentions clear by using the ascending operator.

```
var subset = from p in products orderby p.Name ascending select p;
```

If you want to get the items in descending order, you can do so via the descending operator.

```
var subset = from p in products orderby p.Name descending select p;
```

LINQ As a Better Venn Diagramming Tool

The `Enumerable` class supports a set of extension methods that allows you to use two (or more) LINQ queries as the basis to find unions, differences, concatenations, and intersections of data. First, consider the `Except()` extension method, which will return a LINQ result set that contains the differences between two containers, which in this case, is the value Yugo:

```
static void DisplayDiff()
{
    List<string> myCars = new List<String> {"Yugo", "Aztec", "BMW"};
    List<string> yourCars = new List<String> {"BMW", "Saab", "Aztec" };

    var carDiff =(from c in myCars select c)
        .Except(from c2 in yourCars select c2);

    Console.WriteLine("Here is what you don't have, but I do:");
    foreach (string s in carDiff)
        Console.WriteLine(s); // Prints Yugo.
}
```

The `Intersect()` method will return a result set that contains the common data items in a set of containers. For example, the following method returns the sequence Aztec and BMW:

```
static void DisplayIntersection()
{
    List<string> myCars = new List<String> { "Yugo", "Aztec", "BMW" };
    List<string> yourCars = new List<String> { "BMW", "Saab", "Aztec" };

    // Get the common members.
    var carIntersect = (from c in myCars select c)
        .Intersect(from c2 in yourCars select c2);

    Console.WriteLine("Here is what we have in common:");
    foreach (string s in carIntersect)
        Console.WriteLine(s); // Prints Aztec and BMW.
}
```

The `Union()` method, as you would guess, returns a result set that includes all members of a batch of LINQ queries. Like any proper union, you will not find repeating values if a common member appears more than once. Therefore, the following method will print out the values Yugo, Aztec, BMW, and Saab:

```
static void DisplayUnion()
{
    List<string> myCars = new List<String> { "Yugo", "Aztec", "BMW" };
    List<string> yourCars = new List<String> { "BMW", "Saab", "Aztec" };

    // Get the union of these containers.
    var carUnion = (from c in myCars select c)
        .Union(from c2 in yourCars select c2);

    Console.WriteLine("Here is everything:");
    foreach (string s in carUnion)
        Console.WriteLine(s); // Prints all common members.
}
```

Finally, the `Concat()` extension method returns a result set that is a direct concatenation of LINQ result sets. For example, the following method prints out the results Yugo, Aztec, BMW, BMW, Saab, and Aztec:

```
static void DisplayConcat()
{
    List<string> myCars = new List<String> { "Yugo", "Aztec", "BMW" };
    List<string> yourCars = new List<String> { "BMW", "Saab", "Aztec" };

    var carConcat = (from c in myCars select c)
        .Concat(from c2 in yourCars select c2);

    // Prints:
    // Yugo Aztec BMW BMW Saab Aztec.
    foreach (string s in carConcat)
        Console.WriteLine(s);
}
```

Removing Duplicates

When you call the `Concat()` extension method, you could very well end up with redundant entries in the fetched result, which could be exactly what you want in some cases. However, in other cases, you might want to remove duplicate entries in your data. To do so, simply call the `Distinct()` extension method, as shown here:

```
static void DisplayConcatNoDups()
{
    List<string> myCars = new List<String> { "Yugo", "Aztec", "BMW" };
    List<string> yourCars = new List<String> { "BMW", "Saab", "Aztec" };

    var carConcat = (from c in myCars select c)
        .Concat(from c2 in yourCars select c2);

    // Prints:
    // Yugo Aztec BMW Saab Aztec.
    foreach (string s in carConcat.Distinct())
        Console.WriteLine(s);
}
```

LINQ Aggregation Operations

LINQ queries can also be designed to perform various aggregation operations on the result set. The `Count()` extension method is one such aggregation example. Other possibilities include obtaining an average, maximum, minimum, or sum of values using the `Max()`, `Min()`, `Average()`, or `Sum()` members of the `Enumerable` class. Here is a simple example:

```
static void AggregateOps()
{
    double[] winterTemps = { 2.0, -21.3, 8, -4, 0, 8.2 };

    // Various aggregation examples.
    Console.WriteLine("Max temp: {0}",
        (from t in winterTemps select t).Max());

    Console.WriteLine("Min temp: {0}",
        (from t in winterTemps select t).Min());

    Console.WriteLine("Average temp: {0}",
        (from t in winterTemps select t).Average());

    Console.WriteLine("Sum of all temps: {0}",
        (from t in winterTemps select t).Sum());
}
```

These examples should give you enough knowledge to feel comfortable with the process of building LINQ query expressions. While there are additional operators you have not yet examined, you will see further examples later in this text when you learn about related LINQ technologies. To wrap up your first look at LINQ, the remainder of this chapter will dive into the details between the C# LINQ query operators and the underlying object model.

■ **Source Code** The `FunWithLinqExpressions` project can be found in the [Chapter 12](#) subdirectory.

The Internal Representation of LINQ Query Statements

At this point, you have been introduced to the process of building query expressions using various C# query operators (such as `from`, `in`, `where`, `orderby`, and `select`). Also, you discovered that some functionality of the LINQ to Objects API can be accessed only when calling extension methods of the `Enumerable` class. The truth of the matter, however, is that when compiled, the C# compiler actually translates all C# LINQ operators into calls on methods of the `Enumerable` class.

A great many of the methods of `Enumerable` have been prototyped to take delegates as arguments. In particular, many methods require a generic delegate named `Func<>`, which was introduced to you during your examination of generic delegates in [Chapter 9](#). Consider the `Where()` method of `Enumerable`, which is called on your behalf when you use the C# `where` LINQ query operator.

// Overloaded versions of the `Enumerable.Where<T>()` method.

// Note the second parameter is of type `System.Func<>`.

```
public static IEnumerable<TSource> Where<TSource>(this IEnumerable<TSource> source,
    System.Func<TSource,int,bool> predicate)
```

```
public static IEnumerable<TSource> Where<TSource>(this IEnumerable<TSource> source,
    System.Func<TSource,bool> predicate)
```

The `Func<>` delegate (as the name implies) represents a pattern for a given function with a set of up to 16 arguments and a return value. If you were to examine this type using the Visual Studio object browser, you would notice various forms of the `Func<>` delegate. Here's an example:

// The various formats of the `Func<>` delegate.

```
public delegate TResult Func<T1,T2,T3,T4,TResult>(T1 arg1, T2 arg2, T3 arg3, T4 arg4)
```

```
public delegate TResult Func<T1,T2,T3,TResult>(T1 arg1, T2 arg2, T3 arg3)
```

```
public delegate TResult Func<T1,T2,TResult>(T1 arg1, T2 arg2)
```

```
public delegate TResult Func<T1,TResult>(T1 arg1)
```

```
public delegate TResult Func<TResult>()
```

Given that many members of `System.Linq.Enumerable` demand a delegate as input, when invoking them, you can either manually create a new delegate type and author the necessary target methods, make use of a C# anonymous method, or define a proper lambda expression. Regardless of which approach you take, the end result is identical.

While it is true that making use of C# LINQ query operators is far and away the simplest way to build a LINQ query expression, let's walk through each of these possible approaches, just so you can see the connection between the C# query operators and the underlying `Enumerable` type.

Building Query Expressions with Query Operators (Revisited)

To begin, create a new Console Application project named `LinqUsingEnumerable`. The `Program` class will define a series of static helper methods (each of which is called within the `Main()` method) to illustrate the various manners in which you can build LINQ query expressions.

The first method, `QueryStringsWithOperators()`, offers the most straightforward way to build a query expression and is identical to the code shown in the `LinqOverArray` example earlier in this chapter.

```
static void QueryStringWithOperators()
{
    Console.WriteLine("***** Using Query Operators *****");

    string[] currentVideoGames = {"Morrowind", "Uncharted 2",
        "Fallout 3", "Daxter", "System Shock 2"};

    var subset = from game in currentVideoGames
        where game.Contains(" ") orderby game select game;

    foreach (string s in subset)
        Console.WriteLine("Item: {0}", s);
}
```

The obvious benefit of using C# query operators to build query expressions is that the `Func<>` delegates and calls on the `Enumerable` type are out of sight and out of mind, as it is the job of the C# compiler to perform this translation. To be sure, building LINQ expressions using various query operators (`from`, `in`, `where`, or `orderby`) is the most common and straightforward approach.

Building Query Expressions Using the Enumerable Type and Lambda Expressions

Keep in mind that the LINQ query operators used here are simply shorthand versions for calling various extension methods defined by the `Enumerable` type. Consider the following `QueryStringsWithEnumerableAndLambdas()` method, which is processing the local string array now making direct use of the `Enumerable` extension methods:

```
static void QueryStringsWithEnumerableAndLambdas()
{
    Console.WriteLine("***** Using Enumerable / Lambda Expressions *****");

    string[] currentVideoGames = {"Morrowind", "Uncharted 2",
        "Fallout 3", "Daxter", "System Shock 2"};

    // Build a query expression using extension methods
    // granted to the Array via the Enumerable type.
    var subset = currentVideoGames.Where(game => game.Contains(" "))
        .OrderBy(game => game).Select(game => game);
}
```

```

    // Print out the results.
    foreach (var game in subset)
        Console.WriteLine("Item: {0}", game);
    Console.WriteLine();
}

```

Here, you begin by calling the `Where()` extension method on the `currentVideoGames` string array. Recall that the `Array` class receives this via an extension method granted by `Enumerable`. The `Enumerable.Where()` method requires a `System.Func<T1, TResult>` delegate parameter. The first type parameter of this delegate represents the `IEnumerable<T>` compatible data to process (an array of strings in this case), while the second type parameter represents the method result data, which is obtained from a single statement fed into the lambda expression.

The return value of the `Where()` method is hidden from view in this code example, but under the covers you are operating on an `OrderedEnumerable` type. From this object, you call the generic `OrderBy()` method, which also requires a `Func<>` delegate parameter. This time, you are simply passing each item in turn via a fitting lambda expression. The end result of calling `OrderBy()` is a new ordered sequence of the initial data.

Last but not least, you call the `Select()` method off the sequence returned from `OrderBy()`, which results in the final set of data that is stored in an implicitly typed variable named `subset`.

To be sure, this “longhand” LINQ query is a bit more complex to tease apart than the previous C# LINQ query operator example. Part of the complexity is, no doubt, due to the chaining together of calls using the dot operator. Here is the same query, with each step broken into discrete chunks (as you might guess, you could break down the overall query in various manners):

```

static void QueryStringsIEnumerableAndLambdas2()
{
    Console.WriteLine("***** Using Enumerable / Lambda Expressions *****");

    string[] currentVideoGames = {"Morrowind", "Uncharted 2",
        "Fallout 3", "Daxter", "System Shock 2"};

    // Break it down!
    var gamesWithSpaces = currentVideoGames.Where(game => game.Contains(" "));
    var orderedGames = gamesWithSpaces.OrderBy(game => game);
    var subset = orderedGames.Select(game => game);

    foreach (var game in subset)
        Console.WriteLine("Item: {0}", game);
    Console.WriteLine();
}

```

As you might agree, building a LINQ query expression using the methods of the `Enumerable` class directly is much more verbose than making use of the C# query operators. As well, given that the methods of `Enumerable` require delegates as parameters, you will typically need to author lambda expressions to allow the input data to be processed by the underlying delegate target.

Building Query Expressions Using the Enumerable Type and Anonymous Methods

Given that C# lambda expressions are simply shorthand notations for working with anonymous methods, consider the third query expression created within the `QueryStringsWithAnonymousMethods()` helper function:

```
static void QueryStringsWithAnonymousMethods()
{
    Console.WriteLine("***** Using Anonymous Methods *****");

    string[] currentVideoGames = {"Morrowind", "Uncharted 2",
        "Fallout 3", "Daxter", "System Shock 2"};

    // Build the necessary Func<> delegates using anonymous methods.
    Func<string, bool> searchFilter =
        delegate(string game) { return game.Contains(" "); };
    Func<string, string> itemToProcess = delegate(string s) { return s; };

    // Pass the delegates into the methods of Enumerable.
    var subset = currentVideoGames.Where(searchFilter)
        .OrderBy(itemToProcess).Select(itemToProcess);

    // Print out the results.
    foreach (var game in subset)
        Console.WriteLine("Item: {0}", game);
    Console.WriteLine();
}
```

This iteration of the query expression is even more verbose, because you are manually creating the `Func<>` delegates used by the `Where()`, `OrderBy()`, and `Select()` methods of the `Enumerable` class. On the plus side, the anonymous method syntax does keep all the delegate processing contained within a single method definition. Nevertheless, this method is functionally equivalent to the `QueryStringsWithEnumerableAndLambdas()` and `QueryStringsWithOperators()` methods created in the previous sections.

Building Query Expressions Using the Enumerable Type and Raw Delegates

Finally, if you want to build a query expression using the *really verbose approach*, you could avoid the use of lambdas/anonymous method syntax and directly create delegate targets for each `Func<>` type. Here is the final iteration of your query expression, modeled within a new class type named `VeryComplexQueryExpression`:

```
class VeryComplexQueryExpression
{
    public static void QueryStringsWithRawDelegates()
    {
        Console.WriteLine("***** Using Raw Delegates *****");
    }
}
```

```

string[] currentVideoGames = {"Morrowind", "Uncharted 2",
    "Fallout 3", "Daxter", "System Shock 2"};

// Build the necessary Func<> delegates.
Func<string, bool> searchFilter = new Func<string, bool>(Filter);
Func<string, string> itemToProcess = new Func<string,string>(ProcessItem);

// Pass the delegates into the methods of Enumerable.
var subset = currentVideoGames
    .Where(searchFilter).OrderBy(itemToProcess).Select(itemToProcess);

// Print out the results.
foreach (var game in subset)
    Console.WriteLine("Item: {0}", game);
Console.WriteLine();
}

// Delegate targets.
public static bool Filter(string game) {return game.Contains(" ");}
public static string ProcessItem(string game) { return game; }
}

```

You can test this iteration of your string processing logic by calling this method within the `Main()` method of the `Program` class, as follows:

```
VeryComplexQueryExpression.QueryStringsRawDelegates();
```

If you were to now run the application to test each possible approach, it should not be too surprising that the output is identical, regardless of the path taken. Keep the following points in mind regarding how LINQ query expressions are represented under the covers:

- Query expressions are created using various C# query operators.
- Query operators are simply shorthand notations for invoking extension methods defined by the `System.Linq.Enumerable` type.
- Many methods of `Enumerable` require delegates (`Func<>` in particular) as parameters.
- Any method requiring a delegate parameter can instead be passed a lambda expression.
- Lambda expressions are simply anonymous methods in disguise (which greatly improve readability).
- Anonymous methods are shorthand notations for allocating a raw delegate and manually building a delegate target method.

Whew! That might have been a bit deeper under the hood than you wanted to have gone, but I hope this discussion has helped you understand what the user-friendly C# query operators are actually doing behind the scenes.

■ **Note** The `LinqUsingEnumerable` project can be found in the [Chapter 12](#) subdirectory.

Summary

LINQ is a set of related technologies that attempts to provide a single, symmetrical manner to interact with diverse forms of data. As explained over the course of this chapter, LINQ can interact with any type implementing the `IEnumerable<T>` interface, including simple arrays as well as generic and nongeneric collections of data.

As you have seen, working with LINQ technologies is accomplished using several C# language features. For example, given that LINQ query expressions can return any number of result sets, it is common to make use of the `var` keyword to represent the underlying data type. As well, lambda expressions, object initialization syntax, and anonymous types can all be used to build functional and compact LINQ queries.

More importantly, you have seen how the C# LINQ query operators are simply shorthand notations for making calls on static members of the `System.Linq.Enumerable` type. As shown, most members of `Enumerable` operate on `Func<T>` delegate types, which can take literal method addresses, anonymous methods, or lambda expressions as input to evaluate the query.

CHAPTER 13



Understanding Object Lifetime

At this point in the book, you have learned a great deal about how to build custom class types using C#. Now you will see how the CLR manages allocated class instances (aka objects) via *garbage collection*. C# programmers never directly deallocate a managed object from memory (recall there is no `delete` keyword in the C# language). Rather, .NET objects are allocated to a region of memory termed the *managed heap*, where they will be automatically destroyed by the garbage collector “sometime in the future.”

After you have looked at the core details of the collection process, you’ll learn how to programmatically interact with the garbage collector using the `System.GC` class type (which is something you will typically not be required to do for a majority of your .NET projects). Next, you’ll examine how the virtual `System.Object.Finalize()` method and `IDisposable` interface can be used to build classes that release internal *unmanaged resources* in a predictable and timely manner.

You will also delve into some functionality of the garbage collector introduced in .NET 4.0, including background garbage collections and lazy instantiation using the generic `System.Lazy<>` class. By the time you have completed this chapter, you will have a solid understanding of how .NET objects are managed by the CLR.

Classes, Objects, and References

To frame the topics covered in this chapter, it is important to further clarify the distinction between classes, objects, and reference variables. Recall that a class is nothing more than a blueprint that describes how an instance of this type will look and feel in memory. Classes, of course, are defined within a code file (which in C# takes a *.cs extension by convention). Consider the following simple `Car` class defined within a new C# Console Application project named `SimpleGC`:

```
// Car.cs
public class Car
{
    public int CurrentSpeed {get; set;}
    public string PetName {get; set;}

    public Car(){ }
    public Car(string name, int speed)
    {
        PetName = name;
        CurrentSpeed = speed;
    }
}
```

```

public override string ToString()
{
    return string.Format("{0} is going {1} MPH",
        PetName, CurrentSpeed);
}
}

```

After a class has been defined, you may allocate any number of objects using the C# `new` keyword. Understand, however, that the `new` keyword returns a *reference* to the object on the heap, not the actual object. If you declare the reference variable as a local variable in a method scope, it is stored on the stack for further use in your application. When you want to invoke members on the object, apply the C# dot operator to the stored reference, like so:

```

class Program
{
    static void Main(string[] args)
    {
        Console.WriteLine("***** GC Basics *****");

        // Create a new Car object on
        // the managed heap. We are
        // returned a reference to this
        // object ("refToMyCar").
        Car refToMyCar = new Car("Zippy", 50);

        // The C# dot operator (.) is used
        // to invoke members on the object
        // using our reference variable.
        Console.WriteLine(refToMyCar.ToString());
        Console.ReadLine();
    }
}

```

Figure 13-1 illustrates the class, object, and reference relationship.

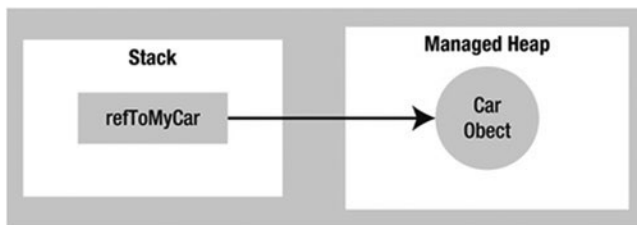

Figure 13-1. References to objects on the managed heap

■ **Note** Recall from Chapter 4 that structures are *value types* that are always allocated directly on the stack and are never placed on the .NET managed heap. Heap allocation occurs only when you are creating instances of classes.

The Basics of Object Lifetime

When you are building your C# applications, you are correct to assume that the .NET runtime environment (aka the CLR) will take care of the managed heap without your direct intervention. In fact, the golden rule of .NET memory management is simple.

■ **Rule** Allocate a class instance onto the managed heap using the `new` keyword and forget about it.

Once instantiated, the garbage collector will destroy an object when it is no longer needed. The next obvious question, of course, is, “How does the garbage collector determine when an object is no longer needed?” The short (i.e., incomplete) answer is that the garbage collector removes an object from the heap only if it is *unreachable* by any part of your code base. Assume you have a method in your `Program` class that allocates a local `Car` object as follows:

```
static void MakeACar()
{
    // If myCar is the only reference to the Car object,
    // it *may* be destroyed when this method returns.
    Car myCar = new Car();
}
```

Notice that this `Car` reference (`myCar`) has been created directly within the `MakeACar()` method and has not been passed outside of the defining scope (via a return value or `ref/out` parameters). Thus, once this method call completes, the `myCar` reference is no longer reachable, and the associated `Car` object is now a candidate for garbage collection. Understand, however, that you can’t guarantee that this object will be reclaimed from memory immediately after `MakeACar()` has completed. All you can assume at this point is that when the CLR performs the next garbage collection, the `myCar` object could be safely destroyed.

As you will most certainly discover, programming in a garbage-collected environment greatly simplifies your application development. In stark contrast, C++ programmers are painfully aware that if they fail to manually delete heap-allocated objects, memory leaks are never far behind. In fact, tracking down memory leaks is one of the most time-consuming (and tedious) aspects of programming in unmanaged environments. By allowing the garbage collector to take charge of destroying objects, the burden of memory management has been lifted from your shoulders and placed onto those of the CLR.

The CIL of `new`

When the C# compiler encounters the `new` keyword, it emits a CIL `newobj` instruction into the method implementation. If you compile the current example code and investigate the resulting assembly using `ildasm.exe`, you’d find the following CIL statements within the `MakeACar()` method:

```
.method private hidebysig static void MakeACar() cil managed
{
    // Code size 8 (0x8)
    .maxstack 1
    .locals init ([0] class SimpleGC.Car myCar)
    IL_0000: nop
    IL_0001: newobj instance void SimpleGC.Car::.ctor()
    IL_0006: stloc.0
    IL_0007: ret
} // end of method Program::MakeACar
```

Before you examine the exact rules that determine when an object is removed from the managed heap, let's check out the role of the CIL `newobj` instruction in a bit more detail. First, understand that the managed heap is more than just a random chunk of memory accessed by the CLR. The .NET garbage collector is quite a tidy housekeeper of the heap, given that it will compact empty blocks of memory (when necessary) for the purposes of optimization.

To aid in this endeavor, the managed heap maintains a pointer (commonly referred to as the *next object pointer* or *new object pointer*) that identifies exactly where the next object will be located. That said, the `newobj` instruction tells the CLR to perform the following core operations:

1. Calculate the total amount of memory required for the object to be allocated (including the memory required by the data members and the base classes).
2. Examine the managed heap to ensure that there is indeed enough room to host the object to be allocated. If there is, the specified constructor is called, and the caller is ultimately returned a reference to the new object in memory, whose address just happens to be identical to the last position of the next object pointer.
3. Finally, before returning the reference to the caller, advance the next object pointer to point to the next available slot on the managed heap.

Figure 13-2 illustrates the basic process.

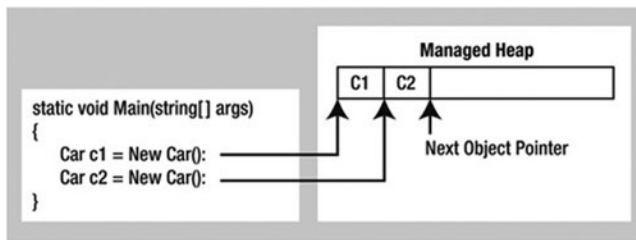

Figure 13-2. The details of allocating objects onto the managed heap

As your application is busy allocating objects, the space on the managed heap may eventually become full. When processing the `newobj` instruction, if the CLR determines that the managed heap does not have sufficient memory to allocate the requested type, it will perform a garbage collection in an attempt to free up memory. Thus, the next rule of garbage collection is also quite simple.

■ **Rule** If the managed heap does not have sufficient memory to allocate a requested object, a garbage collection will occur.

Exactly *how* this garbage collection occurs, however, depends on which version of the .NET platform your application is running under. You'll look at the differences a bit later in this chapter.

Setting Object References to null

C/C++ programmers often set pointer variables to null to ensure they are no longer referencing unmanaged memory. Given this, you might wonder what the end result is of assigning object references to null under C#. For example, assume the `MakeACar()` subroutine has now been updated as follows:

```
static void MakeACar()
{
    Car myCar = new Car();
    myCar = null;
}
```

When you assign object references to null, the compiler generates CIL code that ensures the reference (`myCar`, in this example) no longer points to any object. If you once again made use of `ildasm.exe` to view the CIL code of the modified `MakeACar()`, you would find the `ldnull` opcode (which pushes a null value on the virtual execution stack) followed by a `stloc.0` opcode (which sets the null reference on the variable).

```
.method private hidebysig static void MakeACar() cil managed
{
    // Code size 10 (0xa)
    .maxstack 1
    .locals init ([0] class SimpleGC.Car myCar)
    IL_0000: nop
    IL_0001: newobj instance void SimpleGC.Car::.ctor()
    IL_0006: stloc.0
    IL_0007: ldnull
    IL_0008: stloc.0
    IL_0009: ret
} // end of method Program::MakeACar
```

What you must understand, however, is that assigning a reference to null does not in any way force the garbage collector to fire up at that exact moment and remove the object from the heap. The only thing you have accomplished is explicitly clipping the connection between the reference and the object it previously pointed to. Given this point, setting references to null under C# is far less consequential than doing so in other C-based languages; however, doing so will certainly not cause any harm.

The Role of Application Roots

Now, back to the topic of how the garbage collector determines when an object is no longer needed. To understand the details, you need to be aware of the notion of *application roots*. Simply put, a *root* is a storage location containing a reference to an object on the managed heap. Strictly speaking, a root can fall into any of the following categories:

- References to global objects (though these are not allowed in C#, CIL code does permit allocation of global objects)
- References to any static objects/static fields
- References to local objects within an application's code base
- References to object parameters passed into a method
- References to objects waiting to be *finalized* (described later in this chapter)
- Any CPU register that references an object

During a garbage collection process, the runtime will investigate objects on the managed heap to determine whether they are still reachable (i.e., rooted) by the application. To do so, the CLR will build an *object graph*, which represents each reachable object on the heap. Object graphs are explained in some detail during the discussion of object serialization in Chapter 20. For now, just understand that object graphs are used to document all reachable objects. As well, be aware that the garbage collector will never graph the same object twice, thus avoiding the nasty circular reference count found in COM programming.

Assume the managed heap contains a set of objects named A, B, C, D, E, F, and G. During a garbage collection, these objects (as well as any internal object references they may contain) are examined for active roots. After the graph has been constructed, unreachable objects (which you can assume are objects C and F) are marked as garbage. Figure 13-3 diagrams a possible object graph for the scenario just described (you can read the directional arrows using the phrase *depends on* or *requires*; for example, E depends on G and B, A depends on nothing, and so on).

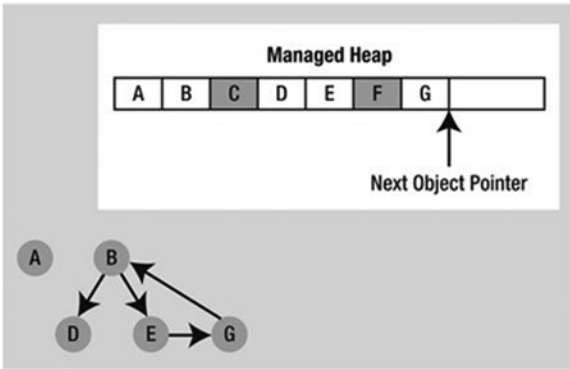

Figure 13-3. Object graphs are constructed to determine which objects are reachable by application roots

After objects have been marked for termination (C and F in this case—as they are not accounted for in the object graph), they are swept from memory. At this point, the remaining space on the heap is compacted, which in turn causes the CLR to modify the set of active application roots (and the underlying pointers) to refer to the correct memory location (this is done automatically and transparently). Last but not least, the next object pointer is readjusted to point to the next available slot. Figure 13-4 illustrates the resulting readjustment.

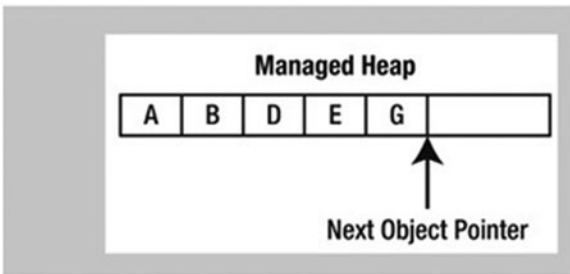

Figure 13-4. A clean and compacted heap

■ **Note** Strictly speaking, the garbage collector uses two distinct heaps, one of which is specifically used to store large objects. This heap is less frequently consulted during the collection cycle, given possible performance penalties involved with relocating large objects. Regardless, it is safe to consider the managed heap as a single region of memory.

Understanding Object Generations

When the CLR is attempting to locate unreachable objects, it does not literally examine every object placed on the managed heap. Doing so, obviously, would involve considerable time, especially in larger (i.e., real-world) applications.

To help optimize the process, each object on the heap is assigned to a specific “generation.” The idea behind generations is simple: the longer an object has existed on the heap, the more likely it is to stay there. For example, the class that defined the main window of a desktop application will be in memory until the program terminates. Conversely, objects that have only recently been placed on the heap (such as an object allocated within a method scope) are likely to be unreachable rather quickly. Given these assumptions, each object on the heap belongs to one of the following generations:

- *Generation 0*: Identifies a newly allocated object that has never been marked for collection
- *Generation 1*: Identifies an object that has survived a garbage collection (i.e., it was marked for collection but was not removed because the sufficient heap space was acquired)
- *Generation 2*: Identifies an object that has survived more than one sweep of the garbage collector

■ **Note** Generations 0 and 1 are termed *ephemeral generations*. As explained in the next section, you will see that the garbage collection process does treat ephemeral generations differently.

The garbage collector will investigate all generation 0 objects first. If marking and sweeping (or said more plainly, getting rid of) these objects results in the required amount of free memory, any surviving objects are promoted to generation 1. To see how an object’s generation affects the collection process, ponder Figure 13-5, which diagrams how a set of surviving generation 0 objects (A, B, and E) are promoted once the required memory has been reclaimed.

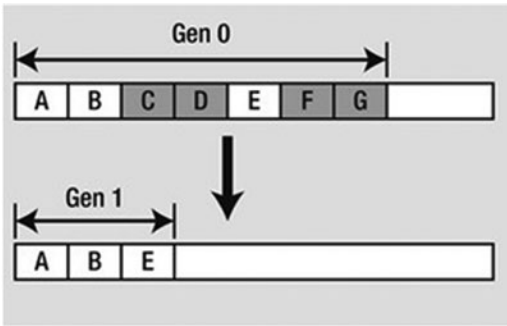

Figure 13-5. Generation 0 objects that survive a garbage collection are promoted to generation 1

If all generation 0 objects have been evaluated but additional memory is still required, generation 1 objects are then investigated for reachability and collected accordingly. Surviving generation 1 objects are then promoted to generation 2. If the garbage collector *still* requires additional memory, generation 2 objects are evaluated. At this point, if a generation 2 object survives a garbage collection, it remains a generation 2 object, given the predefined upper limit of object generations.

The bottom line is that by assigning a generational value to objects on the heap, newer objects (such as local variables) will be removed quickly, while older objects (such as a program's main window) are not “bothered” as often.

Concurrent Garbage Collection Prior to .NET 4.0

Prior to .NET 4.0, the runtime would clean up unused objects using a technique termed *concurrent garbage collection*. Under this model, when a collection takes place for any generation 0 or generation 1 objects (recall these are *ephemeral generations*), the garbage collector temporarily suspends all active *threads* within the current process to ensure that the application does not access the managed heap during the collection process.

You will examine the topic of threads in Chapter 19; for the time being, simply regard a thread as a path of execution within a running executable. After the garbage collection cycle has completed, the suspended threads are permitted to carry on their work. Thankfully, the .NET 3.5 (and earlier) garbage collector was highly optimized; you seldom (if ever) noticed this brief interruption in your application.

As an optimization, concurrent garbage collection allowed objects that were not located in one of the ephemeral generations to be cleaned up on a dedicated thread. This decreased (but didn't eliminate) the need for the .NET runtime to suspect active threads. Moreover, concurrent garbage collection allowed your program to continue allocating objects on the heap during the collection of nonephemeral generations.

Background Garbage Collection Under .NET 4.0 and Beyond

Beginning with .NET 4.0, the garbage collector is able to deal with thread suspension when it cleans up objects on the managed heap, using *background garbage collection*. Despite its name, this does not mean that all garbage collection now takes place on additional background threads of execution. Rather, if a background garbage collection is taking place for objects living in a nonephemeral generation, the .NET runtime is now able to collect objects on the ephemeral generations using a dedicated background thread.

On a related note, the .NET 4.0 and higher garbage collection has been improved to further reduce the amount of time a given thread involved with garbage collection details must be suspended. The end result of these changes is that the process of cleaning up unused objects living in generation 0 or generation 1 has been optimized and can result in better runtime performance of your programs (which is really important for real-time systems that require small, and predictable, GC stop time).

Do understand, however, that the introduction of this new garbage collection model has no effect on how you build your .NET applications. For all practical purposes, you can simply allow the .NET garbage collector to perform its work without your direct intervention (and be happy that the folks at Microsoft are improving the collection process in a transparent manner).

The System.GC Type

The `mscorlib.dll` assembly provides a class type named `System.GC` that allows you to programmatically interact with the garbage collector using a set of static members. Now, do be aware that you will seldom (if ever) need to make use of this class directly in your code. Typically, the only time you will use the members of `System.GC` is when you are creating classes that make internal use of *unmanaged resources*. This could be the case if you are building a class that makes calls into the Windows C-based API using the .NET platform invocation protocol or perhaps because of some very low-level and complicated COM interop logic. Table 13-1 provides a rundown of some of the more interesting members (consult the .NET Framework SDK documentation for complete details).

Table 13-1. Select Members of the `System.GC` Type

| System.GC Member | Description |
|---|---|
| <code>AddMemoryPressure()</code> <code>RemoveMemoryPressure()</code> | Allows you to specify a numerical value that represents the calling object's "urgency level" regarding the garbage collection process. Be aware that these methods should alter pressure <i>in tandem</i> and, thus, never remove more pressure than the total amount you have added. |
| <code>Collect()</code> | Forces the GC to perform a garbage collection. This method has been overloaded to specify a generation to collect, as well as the mode of collection (via the <code>GC.CollectionMode</code> enumeration). |
| <code>CollectionCount()</code> | Returns a numerical value representing how many times a given generation has been swept. |
| <code>GetGeneration()</code> | Returns the generation to which an object currently belongs. |
| <code>GetTotalMemory()</code> | Returns the estimated amount of memory (in bytes) currently allocated on the managed heap. A Boolean parameter specifies whether the call should wait for garbage collection to occur before returning. |
| <code>MaxGeneration</code> | Returns the maximum number of generations supported on the target system. Under Microsoft's .NET 4.0, there are three possible generations: 0, 1, and 2. |
| <code>SuppressFinalize()</code> | Sets a flag indicating that the specified object should not have its <code>Finalize()</code> method called. |
| <code>WaitForPendingFinalizers()</code> | Suspends the current thread until all finalizable objects have been finalized. This method is typically called directly after invoking <code>GC.Collect()</code> . |

To illustrate how the `System.GC` type can be used to obtain various garbage collection–centric details, consider the following `Main()` method, which makes use of several members of `GC`:

```
static void Main(string[] args)
{
    Console.WriteLine("***** Fun with System.GC *****");

    // Print out estimated number of bytes on heap.
    Console.WriteLine("Estimated bytes on heap: {0}",
        GC.GetTotalMemory(false));

    // MaxGeneration is zero based, so add 1 for display purposes.
    Console.WriteLine("This OS has {0} object generations.\n",
        (GC.MaxGeneration + 1));

    Car refToMyCar = new Car("Zippy", 100);
    Console.WriteLine(refToMyCar.ToString());

    // Print out generation of refToMyCar object.
    Console.WriteLine("Generation of refToMyCar is: {0}",
        GC.GetGeneration(refToMyCar));
    Console.ReadLine();
}
```

Forcing a Garbage Collection

Again, the whole purpose of the .NET garbage collector is to manage memory on your behalf. However, in some rare circumstances, it may be beneficial to programmatically force a garbage collection using `GC.Collect()`.

Here are two common situations where you might consider interacting with the collection process:

- Your application is about to enter into a block of code that you don't want interrupted by a possible garbage collection.
- Your application has just finished allocating an extremely large number of objects and you want to remove as much of the acquired memory as soon as possible.

If you determine it could be beneficial to have the garbage collector check for unreachable objects, you could explicitly trigger a garbage collection, as follows:

```
static void Main(string[] args)
{
    ...
    // Force a garbage collection and wait for
    // each object to be finalized.
    GC.Collect();
    GC.WaitForPendingFinalizers();
    ...
}
```

When you manually force a garbage collection, you should always make a call to `GC.WaitForPendingFinalizers()`. With this approach, you can rest assured that all *finalizable objects* (described in the next section) have had a chance to perform any necessary cleanup before your program continues. Under the hood, `GC.WaitForPendingFinalizers()` will suspend the calling thread during the collection process. This is a good thing, as it ensures your code does not invoke methods on an object currently being destroyed!

The `GC.Collect()` method can also be supplied a numerical value that identifies the oldest generation on which a garbage collection will be performed. For example, to instruct the CLR to investigate only generation 0 objects, you would write the following:

```
static void Main(string[] args)
{
    ...
    // Only investigate generation 0 objects.
    GC.Collect(0);
    GC.WaitForPendingFinalizers();
    ...
}
```

As well, the `Collect()` method can also be passed in a value of the `GC.CollectionMode` enumeration as a second parameter, to fine-tune exactly how the runtime should force the garbage collection. This enum defines the following values:

```
public enum GC.CollectionMode
{
    Default, // Forced is the current default.
    Forced, // Tells the runtime to collect immediately!
    Optimized // Allows the runtime to determine
              // whether the current time is optimal to reclaim objects.
}
```

As with any garbage collection, calling `GC.Collect()` promotes surviving generations. To illustrate, assume that your `Main()` method has been updated as follows:

```
static void Main(string[] args)
{
    Console.WriteLine("***** Fun with System.GC *****");

    // Print out estimated number of bytes on heap.
    Console.WriteLine("Estimated bytes on heap: {0}",
        GC.GetTotalMemory(false));

    // MaxGeneration is zero based.
    Console.WriteLine("This OS has {0} object generations.\n",
        (GC.MaxGeneration + 1));
    Car refToMyCar = new Car("Zippy", 100);
    Console.WriteLine(refToMyCar.ToString());

    // Print out generation of refToMyCar.
    Console.WriteLine("\nGeneration of refToMyCar is: {0}",
        GC.GetGeneration(refToMyCar));
}
```

```

// Make a ton of objects for testing purposes.
object[] tonsOfObjects = new object[50000];
for (int i = 0; i < 50000; i++)
    tonsOfObjects[i] = new object();

// Collect only gen 0 objects.
GC.Collect(0, GCCollectionMode.Forced);
GC.WaitForPendingFinalizers();

// Print out generation of refToMyCar.
Console.WriteLine("Generation of refToMyCar is: {0}",
    GC.GetGeneration(refToMyCar));

// See if tonsOfObjects[9000] is still alive.
if (tonsOfObjects[9000] != null)
{
    Console.WriteLine("Generation of tonsOfObjects[9000] is: {0}",
        GC.GetGeneration(tonsOfObjects[9000]));
}
else
    Console.WriteLine("tonsOfObjects[9000] is no longer alive.");

// Print out how many times a generation has been swept.
Console.WriteLine("\nGen 0 has been swept {0} times",
    GC.CollectionCount(0));
Console.WriteLine("Gen 1 has been swept {0} times",
    GC.CollectionCount(1));
Console.WriteLine("Gen 2 has been swept {0} times",
    GC.CollectionCount(2));
Console.ReadLine();
}

```

Here, I have purposely created a large array of object types (50,000 to be exact) for testing purposes. As you can see from the output that follows, even though this `Main()` method made only one explicit request for a garbage collection (via the `GC.Collect()` method), the CLR performed a number of them in the background.

```

***** Fun with System.GC *****
Estimated bytes on heap: 70240
This OS has 3 object generations.

Zippy is going 100 MPH

Generation of refToMyCar is: 0
Generation of refToMyCar is: 1
Generation of tonsOfObjects[9000] is: 1

Gen 0 has been swept 1 times
Gen 1 has been swept 0 times
Gen 2 has been swept 0 times

```

At this point, I hope you feel more comfortable regarding the details of object lifetime. In the next section, you'll examine the garbage collection process a bit further by addressing how you can build *finalizable objects*, as well as *disposable objects*. Be aware that the following techniques are typically necessary only if you are building C# classes that maintain internal unmanaged resources.

■ **Source Code** The SimpleGC project is included in the Chapter 13 subdirectory.

Building Finalizable Objects

In Chapter 6, you learned that the supreme base class of .NET, `System.Object`, defines a virtual method named `Finalize()`. The default implementation of this method does nothing whatsoever.

```
// System.Object
public class Object
{
    ...
    protected virtual void Finalize() {}
}
```

When you override `Finalize()` for your custom classes, you establish a specific location to perform any necessary cleanup logic for your type. Given that this member is defined as `protected`, it is not possible to directly call an object's `Finalize()` method from a class instance via the dot operator. Rather, the *garbage collector* will call an object's `Finalize()` method (if supported) before removing the object from memory.

■ **Note** It is illegal to override `Finalize()` on structure types. This makes perfect sense given that structures are value types, which are never allocated on the heap to begin with and, therefore, are not garbage collected! However, if you create a structure that contains unmanaged resources that need to be cleaned up, you can implement the `IDisposable` interface (described shortly).

Of course, a call to `Finalize()` will (eventually) occur during a “natural” garbage collection or possibly when you programmatically force a collection via `GC.Collect()`. In addition, a type's finalizer method will automatically be called when the application domain hosting your application is unloaded from memory. Depending on your background in .NET, you may know that application domains (or simply `AppDomains`) are used to host an executable assembly and any necessary external code libraries. If you are not familiar with this .NET concept, you will be by the time you've finished Chapter 17. For now, note that when your `AppDomain` is unloaded from memory, the CLR automatically invokes finalizers for every finalizable object created during its lifetime.

Now, despite what your developer instincts may tell you, the vast majority of your C# classes will not require any explicit cleanup logic or a custom finalizer. The reason is simple: if your classes are just making use of other managed objects, everything will eventually be garbage-collected. The only time you would need to design a class that can clean up after itself is when you are using *unmanaged resources* (such as raw OS file handles, raw unmanaged database connections, chunks of unmanaged memory, or other unmanaged resources). Under the .NET platform, unmanaged resources are obtained by directly calling into the API of the operating system using Platform Invocation Services (PInvoke) or as a result of some elaborate COM interoperability scenarios. Given this, consider the next rule of garbage collection.

■ **Rule** The only compelling reason to override `Finalize()` is if your C# class is using unmanaged resources via `PInvoke` or complex COM interoperability tasks (typically via various members defined by the `System.Runtime.InteropServices.Marshal` type). The reason is that under these scenarios you are manipulating memory that the CLR cannot manage.

Overriding `System.Object.Finalize()`

In the rare case that you do build a C# class that uses unmanaged resources, you will obviously want to ensure that the underlying memory is released in a predictable manner. Suppose you have created a new C# Console Application project named `SimpleFinalize` and inserted a class named `MyResourceWrapper` that uses an unmanaged resource (whatever that might be) and you want to override `Finalize()`. The odd thing about doing so in C# is that you can't do it using the expected `override` keyword.

```
class MyResourceWrapper
{
    // Compile-time error!
    protected override void Finalize(){ }
}
```

Rather, when you want to configure your custom C# class types to override the `Finalize()` method, you make use of a (C++-like) destructor syntax to achieve the same effect. The reason for this alternative form of overriding a virtual method is that when the C# compiler processes the finalizer syntax, it automatically adds a good deal of required infrastructure within the implicitly overridden `Finalize()` method (shown in just a moment).

C# finalizers look similar to constructors in that they are named identically to the class they are defined within. In addition, finalizers are prefixed with a tilde symbol (`~`). Unlike a constructor, however, a finalizer never takes an access modifier (they are implicitly protected), never takes parameters, and can't be overloaded (only one finalizer per class).

The following is a custom finalizer for `MyResourceWrapper` that will issue a system beep when invoked. Obviously, this example is only for instructional purposes. A real-world finalizer would do nothing more than free any unmanaged resources and would *not* interact with other managed objects, even those referenced by the current object, as you can't assume they are still alive at the point the garbage collector invokes your `Finalize()` method.

```
// Override System.Object.Finalize() via finalizer syntax.
class MyResourceWrapper
{
    ~MyResourceWrapper()
    {
        // Clean up unmanaged resources here.

        // Beep when destroyed (testing purposes only!)
        Console.Beep();
    }
}
```

If you were to examine this C# destructor using `ildasm.exe`, you would see that the compiler inserts some necessary error-checking code. First, the code statements within the scope of your `Finalize()` method are placed within a try block (see Chapter 7). The related `finally` block ensures that your base classes' `Finalize()` method will always execute, regardless of any exceptions encountered within the try scope.

```
.method family hidebysig virtual instance void
  Finalize() cil managed
{
  // Code size      13 (0xd)
  .maxstack 1
  .try
  {
    IL_0000: ldc.i4 0x4e20
    IL_0005: ldc.i4 0x3e8
    IL_000a: call
      void [mscorlib]System.Console::Beep(int32, int32)
    IL_000f: nop
    IL_0010: nop
    IL_0011: leave.s IL_001b
  } // end .try
  finally
  {
    IL_0013: ldarg.0
    IL_0014:
      call instance void [mscorlib]System.Object::Finalize()
    IL_0019: nop
    IL_001a: endfinally
  } // end handler
  IL_001b: nop
  IL_001c: ret
} // end of method MyResourceWrapper::Finalize
```

If you then tested the `MyResourceWrapper` type, you would find that a system beep occurs when the application terminates, given that the CLR will automatically invoke finalizers upon `AppDomain` shutdown.

```
static void Main(string[] args)
{
  Console.WriteLine("***** Fun with Finalizers *****\n");
  Console.WriteLine("Hit the return key to shut down this app");
  Console.WriteLine("and force the GC to invoke Finalize()");
  Console.WriteLine("for finalizable objects created in this AppDomain.");
  Console.ReadLine();
  MyResourceWrapper rw = new MyResourceWrapper();
}
```

■ **Source Code** The `SimpleFinalize` project is included in the Chapter 13 subdirectory.

Detailing the Finalization Process

Not to beat a dead horse, but always remember that the role of the `Finalize()` method is to ensure that a .NET object can clean up unmanaged resources when it is garbage-collected. Thus, if you are building a class that does not make use of unmanaged memory (by far the most common case), finalization is of little use. In fact, if at all possible, you should design your types to avoid supporting a `Finalize()` method for the simple reason that finalization takes time.

When you allocate an object onto the managed heap, the runtime automatically determines whether your object supports a custom `Finalize()` method. If so, the object is marked as *finalizable*, and a pointer to this object is stored on an internal queue named the *finalization queue*. The finalization queue is a table maintained by the garbage collector that points to every object that must be finalized before it is removed from the heap.

When the garbage collector determines it is time to free an object from memory, it examines each entry on the finalization queue and copies the object off the heap to yet another managed structure termed the *finalization reachable table* (often abbreviated as *freachable* and pronounced “eff- reachable”). At this point, a separate thread is spawned to invoke the `Finalize()` method for each object on the freachable table *at the next garbage collection*. Given this, it will take, at the least, two garbage collections to truly finalize an object.

The bottom line is that while finalization of an object does ensure an object can clean up unmanaged resources, it is still nondeterministic in nature and, because of the extra behind-the-curtains processing, considerably slower.

Building Disposable Objects

As you have seen, finalizers can be used to release unmanaged resources when the garbage collector kicks in. However, given that many unmanaged objects are “precious items” (such as raw database or file handles), it could be valuable to release them as soon as possible instead of relying on a garbage collection to occur. As an alternative to overriding `Finalize()`, your class could implement the `IDisposable` interface, which defines a single method named `Dispose()` as follows:

```
public interface IDisposable
{
    void Dispose();
}
```

When you do implement the `IDisposable` interface, the assumption is that when the *object user* is finished using the object, the object user manually calls `Dispose()` before allowing the object reference to drop out of scope. In this way, an object can perform any necessary cleanup of unmanaged resources without incurring the hit of being placed on the finalization queue and without waiting for the garbage collector to trigger the class’s finalization logic.

■ **Note** Structures and class types can both implement `IDisposable` (unlike overriding `Finalize()`, which is reserved for class types), as the object user (not the garbage collector) invokes the `Dispose()` method.

To illustrate the use of this interface, create a new C# Console Application project named SimpleDispose. Here is an updated MyResourceWrapper class that now implements IDisposable, rather than overriding System.Object.Finalize():

```
// Implementing IDisposable.
class MyResourceWrapper : IDisposable
{
    // The object user should call this method
    // when they finish with the object.
    public void Dispose()
    {
        // Clean up unmanaged resources...

        // Dispose other contained disposable objects...

        // Just for a test.
        Console.WriteLine("***** In Dispose! *****");
    }
}
```

Notice that a Dispose() method not only is responsible for releasing the type's unmanaged resources but can also call Dispose() on any other contained disposable methods. Unlike with Finalize(), it is perfectly safe to communicate with other managed objects within a Dispose() method. The reason is simple: the garbage collector has no clue about the IDisposable interface and will never call Dispose(). Therefore, when the object user calls this method, the object is still living a productive life on the managed heap and has access to all other heap-allocated objects. The calling logic, shown here, is straightforward:

```
class Program
{
    static void Main(string[] args)
    {
        Console.WriteLine("***** Fun with Dispose *****\n");
        // Create a disposable object and call Dispose()
        // to free any internal resources.
        MyResourceWrapper rw = new MyResourceWrapper();
        rw.Dispose();
        Console.ReadLine();
    }
}
```

Of course, before you attempt to call Dispose() on an object, you will want to ensure the type supports the IDisposable interface. While you will typically know which base class library types implement IDisposable by consulting the .NET Framework 4.5 SDK documentation, a programmatic check can be accomplished using the is or as keywords discussed in Chapter 6.

```
class Program
{
    static void Main(string[] args)
    {
        Console.WriteLine("***** Fun with Dispose *****\n");
        MyResourceWrapper rw = new MyResourceWrapper();
    }
}
```

```

    if (rw is IDisposable)
        rw.Dispose();
    Console.ReadLine();
}
}

```

This example exposes yet another rule regarding memory management.

■ **Rule** It is a good idea to call `Dispose()` on any object you directly create if the object supports `IDisposable`. The assumption you should make is that if the class designer chose to support the `Dispose()` method, the type has some cleanup to perform. If you forget, memory will eventually be cleaned up (so don't panic), but it could take longer than necessary.

There is one caveat to the previous rule. A number of types in the base class libraries that do implement the `IDisposable` interface provide a (somewhat confusing) alias to the `Dispose()` method, in an attempt to make the disposal-centric method sound more natural for the defining type. By way of an example, while the `System.IO.FileStream` class implements `IDisposable` (and therefore supports a `Dispose()` method), it also defines the following `Close()` method that is used for the same purpose:

```

// Assume you have imported
// the System.IO namespace...
static void DisposeFileStream()
{
    FileStream fs = new FileStream("myFile.txt", FileMode.OpenOrCreate);

    // Confusing, to say the least!
    // These method calls do the same thing!
    fs.Close();
    fs.Dispose();
}

```

While it does feel more natural to “close” a file rather than “dispose” of one, this doubling up of cleanup methods can be confusing. For the few types that do provide an alias, just remember that if a type implements `IDisposable`, calling `Dispose()` is always a safe course of action.

Reusing the C# using Keyword

When you are handling a managed object that implements `IDisposable`, it is quite common to make use of structured exception handling to ensure the type's `Dispose()` method is called in the event of a runtime exception, like so:

```

static void Main(string[] args)
{
    Console.WriteLine("***** Fun with Dispose *****\n");
    MyResourceWrapper rw = new MyResourceWrapper ();
    try
    {
        // Use the members of rw.
    }
}

```

```

finally
{
    // Always call Dispose(), error or not.
    rw.Dispose();
}
}

```

While this is a fine example of defensive programming, the truth of the matter is that few developers are thrilled by the prospects of wrapping every disposable type within a try/finally block just to ensure the `Dispose()` method is called. To achieve the same result in a much less obtrusive manner, C# supports a special bit of syntax that looks like this:

```

static void Main(string[] args)
{
    Console.WriteLine("***** Fun with Dispose *****\n");
    // Dispose() is called automatically when the
    // using scope exits.
    using(MyResourceWrapper rw = new MyResourceWrapper())
    {
        // Use rw object.
    }
}

```

If you looked at the following CIL code of the `Main()` method using `ildasm.exe`, you would find the using syntax does indeed expand to try/finally logic, with the expected call to `Dispose()`:

```

.method private hidebysig static void Main(string[] args) cil managed
{
    ...
    .try
    {
        ...
    } // end .try
    finally
    {
        ...
        IL_0012: callvirt instance void
            SimpleFinalize.MyResourceWrapper::Dispose()
        } // end handler
    ...
} // end of method Program::Main

```

■ **Note** If you attempt to “use” an object that does not implement `IDisposable`, you will receive a compiler error.

While this syntax does remove the need to manually wrap disposable objects within try/finally logic, the C# using keyword unfortunately now has a double meaning (importing namespaces and invoking a `Dispose()` method). Nevertheless, when you are working with .NET types that support the `IDisposable` interface, this syntactical construct will ensure that the object “being used” will automatically have its `Dispose()` method called once the using block has exited.

Also, be aware that it is possible to declare multiple objects *of the same type* within a using scope. As you would expect, the compiler will inject code to call `Dispose()` on each declared object.

```
static void Main(string[] args)
{
    Console.WriteLine("***** Fun with Dispose *****\n");

    // Use a comma-delimited list to declare multiple objects to dispose.
    using(MyResourceWrapper rw = new MyResourceWrapper(),
          rw2 = new MyResourceWrapper())
    {
        // Use rw and rw2 objects.
    }
}
```

■ **Source Code** The SimpleDispose project is included in the Chapter 13 subdirectory.

Building Finalizable and Disposable Types

At this point, you have seen two different approaches to constructing a class that cleans up internal unmanaged resources. On the one hand, you can use a finalizer. Using this technique, you have the peace of mind that comes with knowing the object cleans itself up when garbage-collected (whenever that may be) without the need for user interaction. On the other hand, you can implement `IDisposable` to provide a way for the object user to clean up the object as soon as it is finished. However, if the caller forgets to call `Dispose()`, the unmanaged resources may be held in memory indefinitely.

As you might suspect, it is possible to blend both techniques into a single class definition. By doing so, you gain the best of both models. If the object user does remember to call `Dispose()`, you can inform the garbage collector to bypass the finalization process by calling `GC.SuppressFinalize()`. If the object user forgets to call `Dispose()`, the object will eventually be finalized and have a chance to free up the internal resources. The good news is that the object's internal unmanaged resources will be freed one way or another.

Here is the next iteration of `MyResourceWrapper`, which is now finalizable and disposable, defined in a C# Console Application project named `FinalizableDisposableClass`:

```
// A sophisticated resource wrapper.
public class MyResourceWrapper : IDisposable
{
    // The garbage collector will call this method if the
    // object user forgets to call Dispose().
    ~MyResourceWrapper()
    {
        // Clean up any internal unmanaged resources.
        // Do not call Dispose() on any managed objects.
    }
    // The object user will call this method to clean up
    // resources ASAP.
}
```

```

public void Dispose()
{
    // Clean up unmanaged resources here.
    // Call Dispose() on other contained disposable objects.
    // No need to finalize if user called Dispose(),
    // so suppress finalization.
    GC.SuppressFinalize(this);
}
}

```

Notice that this `Dispose()` method has been updated to call `GC.SuppressFinalize()`, which informs the CLR that it is no longer necessary to call the destructor when this object is garbage-collected, given that the unmanaged resources have already been freed via the `Dispose()` logic.

A Formalized Disposal Pattern

The current implementation of `MyResourceWrapper` does work fairly well; however, you are left with a few minor drawbacks. First, the `Finalize()` and `Dispose()` methods each have to clean up the same unmanaged resources. This could result in duplicate code, which can easily become a nightmare to maintain. Ideally, you would define a private helper function that is called by either method.

Next, you'd like to make sure that the `Finalize()` method does not attempt to dispose of any managed objects, while the `Dispose()` method should do so. Finally, you'd also like to be certain the object user can safely call `Dispose()` multiple times without error. Currently, the `Dispose()` method has no such safeguards.

To address these design issues, Microsoft defined a formal, prim-and-proper disposal pattern that strikes a balance between robustness, maintainability, and performance. Here is the final (and annotated) version of `MyResourceWrapper`, which makes use of this official pattern:

```

class MyResourceWrapper : IDisposable
{
    // Used to determine if Dispose()
    // has already been called.
    private bool disposed = false;

    public void Dispose()
    {
        // Call our helper method.
        // Specifying "true" signifies that
        // the object user triggered the cleanup.
        Cleanup(true);

        // Now suppress finalization.
        GC.SuppressFinalize(this);
    }

    private void Cleanup(bool disposing)
    {
        // Be sure we have not already been disposed!
        if (!this.disposed)
        {

```

```

        // If disposing equals true, dispose all
        // managed resources.
        if (disposing)
        {
            // Dispose managed resources.
        }
        // Clean up unmanaged resources here.
    }
    disposed = true;
}
~MyResourceWrapper()
{
    // Call our helper method.
    // Specifying "false" signifies that
    // the GC triggered the cleanup.
    Cleanup(false);
}
}

```

Notice that `MyResourceWrapper` now defines a private helper method named `Cleanup()`. By specifying `true` as an argument, you indicate that the object user has initiated the cleanup, so you should clean up all managed *and* unmanaged resources. However, when the garbage collector initiates the cleanup, you specify `false` when calling `Cleanup()` to ensure that internal disposable objects are *not* disposed (as you can't assume they are still in memory!). Last but not least, the `bool` member variable (`disposed`) is set to `true` before exiting `Cleanup()` to ensure that `Dispose()` can be called numerous times without error.

■ **Note** After an object has been “disposed,” it's still possible for the client to invoke members on it, as it is still in memory. Therefore, a robust resource wrapper class would also need to update each member of the class with additional coding logic that says, in effect, “If I am disposed, do nothing and return from the member.”

To test the final iteration of `MyResourceWrapper`, add a call to `Console.Beep()` within the scope of your finalizer, like so:

```

~MyResourceWrapper()
{
    Console.Beep();
    // Call our helper method.
    // Specifying "false" signifies that
    // the GC triggered the cleanup.
    Cleanup(false);
}

```

Next, update `Main()` as follows:

```

static void Main(string[] args)
{
    Console.WriteLine("***** Dispose() / Destructor Combo Platter *****");
}

```

```

// Call Dispose() manually. This will not call the finalizer.
MyResourceWrapper rw = new MyResourceWrapper();
rw.Dispose();

// Don't call Dispose(). This will trigger the finalizer
// and cause a beep.
MyResourceWrapper rw2 = new MyResourceWrapper();
}

```

Notice that you are explicitly calling `Dispose()` on the `rw` object, so the destructor call is suppressed. However, you have “forgotten” to call `Dispose()` on the `rw2` object, and therefore, when the application terminates, you hear a single beep. If you were to comment out the call to `Dispose()` on the `rw` object, you would hear two beeps.

■ **Source Code** The `FinalizableDisposableClass` project is included in the Chapter 13 subdirectory.

That concludes your investigation of how the CLR manages your objects via garbage collection. While there are additional (somewhat esoteric) details regarding the collection process I haven’t covered here (such as weak references and object resurrection), you are now in a perfect position for further exploration on your own. To wrap this chapter up, you will examine a programming feature called *lazy instantiation* of objects.

Understanding Lazy Object Instantiation

When you are creating classes, you might occasionally need to account for a particular member variable in code, which might never actually be needed, in that the object user might not call the method (or property) that makes use of it. Fair enough. However, this can be problematic if the member variable in question requires a large amount of memory to be instantiated.

For example, assume you are writing a class that encapsulates the operations of a digital music player. In addition to the expected methods, such as `Play()`, `Pause()`, and `Stop()`, you also want to provide the ability to return a collection of `Song` objects (via a class named `AllTracks`), which represents every single digital music file on the device.

If you’d like to follow along, create a new Console Application project named `LazyObjectInstantiation`, and define the following class types:

```

// Represents a single song.
class Song
{
    public string Artist { get; set; }
    public string TrackName { get; set; }
    public double TrackLength { get; set; }
}

// Represents all songs on a player.
class AllTracks
{
    // Our media player can have a maximum
    // of 10,000 songs.
    private Song[] allSongs = new Song[10000];
}

```

```

public AllTracks()
{
    // Assume we fill up the array
    // of Song objects here.
    Console.WriteLine("Filling up the songs!");
}
}

```

// The MediaPlayer has-an AllTracks object.

```

class MediaPlayer
{
    // Assume these methods do something useful.
    public void Play() { /* Play a song */ }
    public void Pause() { /* Pause the song */ }
    public void Stop() { /* Stop playback */ }
    private AllTracks allSongs = new AllTracks();

    public AllTracks GetAllTracks()
    {
        // Return all of the songs.
        return allSongs;
    }
}

```

The current implementation of `MediaPlayer` assumes that the object user will want to obtain a list of songs via the `GetAllTracks()` method. Well, what if the object user does *not* need to obtain this list? In the current implementation, the `AllTracks` member variable will still be allocated, thereby creating 10,000 `Song` objects in memory, as follows:

```

static void Main(string[] args)
{
    Console.WriteLine("***** Fun with Lazy Instantiation *****\n");

    // This caller does not care about getting all songs,
    // but indirectly created 10,000 objects!
    MediaPlayer myPlayer = new MediaPlayer();
    myPlayer.Play();

    Console.ReadLine();
}

```

Clearly, you would rather not create 10,000 objects that nobody will use, as that will add a good deal of stress to the .NET garbage collector. While you could manually add some code to ensure the `allSongs` object is created only if used (perhaps using the factory method design pattern), there is an easier way.

The base class libraries provide a useful generic class named `Lazy<>`, defined in the `System` namespace of `mscorlib.dll`. This class allows you to define data that will *not* be created unless your code base actually uses it. As this is a generic class, you must specify the type of item to be created on first use, which can be any type with the .NET base class libraries or a custom type you have authored yourself. To enable lazy instantiation of the `AllTracks` member variable, you can simply replace this:

```
// The MediaPlayer has-an AllTracks object.
class MediaPlayer
{
    ...
    private AllTracks allSongs = new AllTracks();

    public AllTracks GetAllTracks()
    {
        // Return all of the songs.
        return allSongs;
    }
}
```

with this:

```
// The MediaPlayer has-an Lazy<AllTracks> object.
class MediaPlayer
{
    ...
    private Lazy<AllTracks> allSongs = new Lazy<AllTracks>();
    public AllTracks GetAllTracks()
    {
        // Return all of the songs.
        return allSongs.Value;
    }
}
```

Beyond the fact that you are now representing the `AllTracks` member variable as a `Lazy<>` type, notice that the implementation of the previous `GetAllTracks()` method has also been updated. Specifically, you must use the read-only `Value` property of the `Lazy<>` class to obtain the actual stored data (in this case, the `AllTracks` object that is maintaining the 10,000 `Song` objects).

With this simple update, notice how the following updated `Main()` method will indirectly allocate the `Song` objects only if `GetAllTracks()` is indeed called:

```
static void Main(string[] args)
{
    Console.WriteLine("***** Fun with Lazy Instantiation *****\n");

    // No allocation of AllTracks object here!
    MediaPlayer myPlayer = new MediaPlayer();
    myPlayer.Play();

    // Allocation of AllTracks happens when you call GetAllTracks().
    MediaPlayer yourPlayer = new MediaPlayer();
    AllTracks yourMusic = yourPlayer.GetAllTracks();

    Console.ReadLine();
}
```

■ **Note** Lazy object instantiation is useful not only to decrease allocation of unnecessary objects. You can also use this technique if a given member has expensive creation code, such as invoking a remote method, communication with a relational database, or what not.

Customizing the Creation of the Lazy Data

When you declare a `Lazy<>` variable, the actual internal data type is created using the default constructor, like so:

```
// Default constructor of AllTracks is called when the Lazy<>
// variable is used.
private Lazy<AllTracks> allSongs = new Lazy<AllTracks>();
```

While this might be fine in some cases, what if the `AllTracks` class had some additional constructors and you want to ensure the correct one is called? Furthermore, what if you have some extra work to do (beyond simply creating the `AllTracks` object) when the `Lazy<>` variable is made? As luck would have it, the `Lazy<>` class allows you to specify a generic delegate as an optional parameter, which will specify a method to call during the creation of the wrapped type.

The generic delegate in question is of type `System.Func<>`, which can point to a method that returns the same data type being created by the related `Lazy<>` variable and can take up to 16 arguments (which are typed using generic type parameters). In most cases, you will not need to specify any parameters to pass to the method pointed to by `Func<>`. Furthermore, to greatly simplify the use of the required `Func<>`, I recommend using a lambda expression (see Chapter 10 to review the delegate/lambda relationship).

With this in mind, the following is a final version of `MediaPlayer` that adds a bit of custom code when the wrapped `AllTracks` object is created. Remember, this method must return a new instance of the type wrapped by `Lazy<>` before exiting, and you can use any constructor you choose (here, you are still invoking the default constructor of `AllTracks`).

```
class MediaPlayer
{
    ...
    // Use a lambda expression to add additional code
    // when the AllTracks object is made.
    private Lazy<AllTracks> allSongs = new Lazy<AllTracks>( () =>
        {
            Console.WriteLine("Creating AllTracks object!");
            return new AllTracks();
        }
    );

    public AllTracks GetAllTracks()
    {
        // Return all of the songs.
        return allSongs.Value;
    }
}
```

Sweet! I hope you can see the usefulness of the `Lazy<>` class. Essentially, this generic class allows you to ensure expensive objects are allocated only when the object user requires them. If you find this topic useful for your projects, you might also want to look up the `System.Lazy<>` class in the .NET Framework 4.5 SDK documentation for further examples of how to program for lazy instantiation.

■ **Source Code** The `LazyObjectInstantiation` project is included in the Chapter 13 subdirectory.

Summary

The point of this chapter was to demystify the garbage collection process. As you saw, the garbage collector will run only when it is unable to acquire the necessary memory from the managed heap (or when a given `AppDomain` unloads from memory). When a collection does occur, you can rest assured that Microsoft's collection algorithm has been optimized by the use of object generations, secondary threads for the purpose of object finalization, and a managed heap dedicated to hosting large objects.

This chapter also illustrated how to programmatically interact with the garbage collector using the `System.GC` class type. As mentioned, the only time you will really need to do so is when you are building finalizable or disposable class types that operate on unmanaged resources.

Recall that finalizable types are classes that have provided a destructor (effectively overriding the `Finalize()` method) to clean up unmanaged resources at the time of garbage collection. Disposable objects, on the other hand, are classes (or structures) that implement the `IDisposable` interface, which should be called by the object user when it is finished using said objects. Finally, you learned about an official "disposal" pattern that blends both approaches.

This chapter wrapped up with a look at a generic class named `Lazy<>`. As you saw, you can use this class to delay the creation of an expensive (in terms of memory consumption) object until the caller actually requires it. By doing so, you can help reduce the number of objects stored on the managed heap and also ensure expensive objects are created only when actually required by the caller.

PART V



Programming with .NET Assemblies

CHAPTER 14



Building and Configuring Class Libraries

During the first four parts of this book, you have created a number of “stand-alone” executable applications, in which all the programming logic was packaged within a single executable file (*.exe). These executable assemblies were using little more than the primary .NET class library, `mscorlib.dll`. While some simple .NET programs may be constructed using nothing more than the .NET base class libraries, chances are it will be commonplace for you (or your teammates) to isolate reusable programming logic into *custom* class libraries (*.dll files) that can be shared among applications.

In this chapter, you will learn about various ways to package your types into custom libraries of code. To begin, you’ll learn the details of partitioning types into .NET namespaces. After this, you will examine the class library project templates of Visual Studio and learn the distinction between private and shared assemblies.

Next, you’ll explore exactly how the .NET runtime resolves the location of an assembly, and you’ll come to understand the global assembly cache, XML application configuration files (*.config files), publisher policy assemblies, and the `System.Configuration` namespace.

Defining Custom Namespaces

Before diving into the aspects of library deployment and configuration, the first task is to learn the details of packaging your custom types into .NET namespaces. Up to this point in the text, you’ve been building small test programs that leverage existing namespaces in the .NET universe (`System`, in particular). However, when you build larger applications with many types, it can be helpful to group your related types into custom namespaces. In C#, this is accomplished using the `namespace` keyword. Explicitly defining custom namespaces is even more important when creating .NET *.dll assemblies, as other developers will need to reference the library and import your custom namespaces to use your types.

To investigate the issues firsthand, begin by creating a new Console Application project named `CustomNamespaces`. Now, assume you are developing a collection of geometric classes named `Square`, `Circle`, and `Hexagon`. Given their similarities, you would like to group them together into a unique namespace called `MyShapes` within the `CustomNamespaces.exe` assembly. You have two basic approaches. First, you can choose to define all classes in a single C# file (`ShapesLib.cs`) as follows:

```
// ShapesLib.cs
using System;

namespace MyShapes
{
    // Circle class
    public class Circle { /* Interesting members... */ }
```

```
// Hexagon class
public class Hexagon { /* More interesting members... */ }

// Square class
public class Square { /* Even more interesting members... */ }
}
```

While the C# compiler has no problems with a single C# code file containing multiple types, this could be cumbersome when you want to reuse class definitions in new projects. For example, say you are building a new project and only need to use the `Circle` class. If all types are defined in a single code file, you are more or less stuck with the entire set. Therefore, as an alternative, you can split a single namespace across multiple C# files. To ensure each type is packaged into the same logical group, simply wrap the given class definitions in the same namespace scope, like so:

// Circle.cs

```
using System;

namespace MyShapes
{
    // Circle class
    public class Circle { /* Interesting methods... */ }
}
```

// Hexagon.cs

```
using System;

namespace MyShapes
{
    // Hexagon class
    public class Hexagon { /* More interesting methods... */ }
}
```

// Square.cs

```
using System;

namespace MyShapes
{
    // Square class
    public class Square { /* Even more interesting methods... */ }
}
```

In both cases, notice how the `MyShapes` namespace acts as the conceptual “container” of these classes. When another namespace (such as `CustomNamespaces`) wants to use types in a separate namespace, you use the `using` keyword, just as you would when using namespaces of the .NET base class libraries, as follows:

```
// Bring in a namespace from the base class libraries.
using System;
```

```
// Make use of types defined the MyShapes namespace.
using MyShapes;
```

```

namespace CustomNamespaces
{
    public class Program
    {
        static void Main(string[] args)
        {
            Hexagon h = new Hexagon();
            Circle c = new Circle();
            Square s = new Square();
        }
    }
}

```

For this particular example, the assumption is that the C# file (or files) that defines the `MyShapes` namespace is part of the same Console Application project that contains the file defining the `CustomNamespaces` namespace; in other words, all the files are used to compile a single .NET executable assembly. If you defined the `MyShapes` namespace within an external assembly, you would also need to add a reference to that library before you could compile successfully. You'll learn all the details of building applications that use external libraries during the course of this chapter.

Resolving Name Clashes with Fully Qualified Names

Technically speaking, you are not required to use the C# `using` keyword when referring to types defined in external namespaces. You could use the *fully qualified name* of the type, which, as you may recall from Chapter 1, is the type's name prefixed with the defining namespace. Here's an example:

```

// Note we are not importing MyShapes anymore!
using System;

namespace CustomNamespaces
{
    public class Program
    {
        static void Main(string[] args)
        {
            MyShapes.Hexagon h = new MyShapes.Hexagon();
            MyShapes.Circle c = new MyShapes.Circle();
            MyShapes.Square s = new MyShapes.Square();
        }
    }
}

```

Typically, there is no need to use a fully qualified name. Not only does it require a greater number of keystrokes, it also makes no difference whatsoever in terms of code size or execution speed. In fact, in CIL code, types are *always* defined with the fully qualified name. In this light, the C# `using` keyword is simply a typing time-saver.

However, fully qualified names can be helpful (and sometimes necessary) to avoid potential name clashes when using multiple namespaces that contain identically named types. Assume you have a new namespace termed `My3DShapes`, which defines the following three classes, capable of rendering a shape in stunning 3D:

```
// Another shape-centric namespace.
using System;
namespace My3DShapes
{
    // 3D Circle class.
    public class Circle { }

    // 3D Hexagon class.
    public class Hexagon { }

    // 3D Square class.
    public class Square { }
}
```

If you update the `Program` class as shown next, you are issued a number of compile-time errors, because both namespaces define identically named classes:

```
// Ambiguities abound!
using System;
using MyShapes;
using My3DShapes;

namespace CustomNamespaces
{
    public class Program
    {
        static void Main(string[] args)
        {
            // Which namespace do I reference?
            Hexagon h = new Hexagon(); // Compiler error!
            Circle c = new Circle();   // Compiler error!
            Square s = new Square();    // Compiler error!
        }
    }
}
```

The ambiguity can be resolved using the type's fully qualified name, like so:

```
// We have now resolved the ambiguity.
static void Main(string[] args)
{
    My3DShapes.Hexagon h = new My3DShapes.Hexagon();
    My3DShapes.Circle c = new My3DShapes.Circle();
    MyShapes.Square s = new MyShapes.Square();
}
```

Resolving Name Clashes with Aliases

The C# `using` keyword also lets you create an alias for a type's fully qualified name. When you do so, you define a token that is substituted for the type's full name at compile time. Defining aliases provides a second way to resolve name clashes. Here's an example:

```
using System;
using MyShapes;
using My3DShapes;

// Resolve the ambiguity using a custom alias.
using The3DHexagon = My3DShapes.Hexagon;

namespace CustomNamespaces
{
    class Program
    {
        static void Main(string[] args)
        {
            // This is really creating a My3DShapes.Hexagon class.
            The3DHexagon h2 = new The3DHexagon();
            ...
        }
    }
}
```

This alternative `using` syntax also lets you create an alias for a lengthy namespace. One of the longer namespaces in the base class library is `System.Runtime.Serialization.Formatters.Binary`, which contains a member named `BinaryFormatter`. If you want, you can create an instance of the `BinaryFormatter` as follows:

```
using bfHome = System.Runtime.Serialization.Formatters.Binary;

namespace MyApp
{
    class ShapeTester
    {
        static void Main(string[] args)
        {
            bfHome.BinaryFormatter b = new bfHome.BinaryFormatter();
            ...
        }
    }
}
```

as well as with a traditional using directive:

```
using System.Runtime.Serialization.Formatters.Binary;

namespace MyApp
{
    class ShapeTester
    {
        static void Main(string[] args)
        {
            BinaryFormatter b = new BinaryFormatter();
            ...
        }
    }
}
```

At this point in the game, there is no need to concern yourself with what the `BinaryFormatter` class is used for (you'll examine this class in [Chapter 20](#)). For now, simply remember that the C# `using` keyword can be used to define aliases for lengthy fully qualified names or, more commonly, to resolve name clashes that can arise when importing multiple namespaces that define identically named types.

■ **Note** Be aware that overuse of C# aliases can result in a confusing code base. If other programmers on your team are unaware of your custom aliases, they could assume the aliases refer to types in the .NET base class libraries and become quite confused when they can't find these tokens in the .NET Framework SDK documentation!

Creating Nested Namespaces

When organizing your types, you are free to define namespaces within other namespaces. The .NET base class libraries do so in numerous places to provide deeper levels of type organization. For example, the `IO` namespace is nested within `System` to yield `System.IO`. If you want to create a root namespace containing the existing `My3DShapes` namespace, you can update your code as follows:

```
// Nesting a namespace.
namespace Chapter14
{
    namespace My3DShapes
    {
        // 3D Circle class.
        public class Circle{ }

        // 3D Hexagon class.
        public class Hexagon{ }

        // 3D Square class.
        public class Square{ }
    }
}
```

In many cases, the role of a root namespace is simply to provide a further level of scope; therefore, it may not define any types directly within its scope (as in the case of the `Chapter14` namespace). If this is the case, a nested namespace can be defined using the following compact form:

```
// Nesting a namespace (take two).
namespace Chapter14.My3DShapes
{
    // 3D Circle class.
    public class Circle{ }

    // 3D Hexagon class.
    public class Hexagon{ }

    // 3D Square class.
    public class Square{ }
}
```

Given that you have now nested the `My3DShapes` namespace within the `Chapter14` root namespace, you need to update any existing `using` directives and type aliases, like so:

```
using Chapter14.My3DShapes;
using The3DHexagon = Chapter14.My3DShapes.Hexagon;
```

The Default Namespace of Visual Studio

On a final namespace-related note, it is worth pointing out that, by default, when you create a new C# project using Visual Studio, the name of your application's default namespace will be identical to the project name. From this point on, when you insert new code files using the `Project ► Add New Item` menu selection, types will automatically be wrapped within the default namespace. If you want to change the name of the default namespace, simply access the `Default namespace` option using the `Application` tab of the project's `Properties` window (see [Figure 14-1](#)).

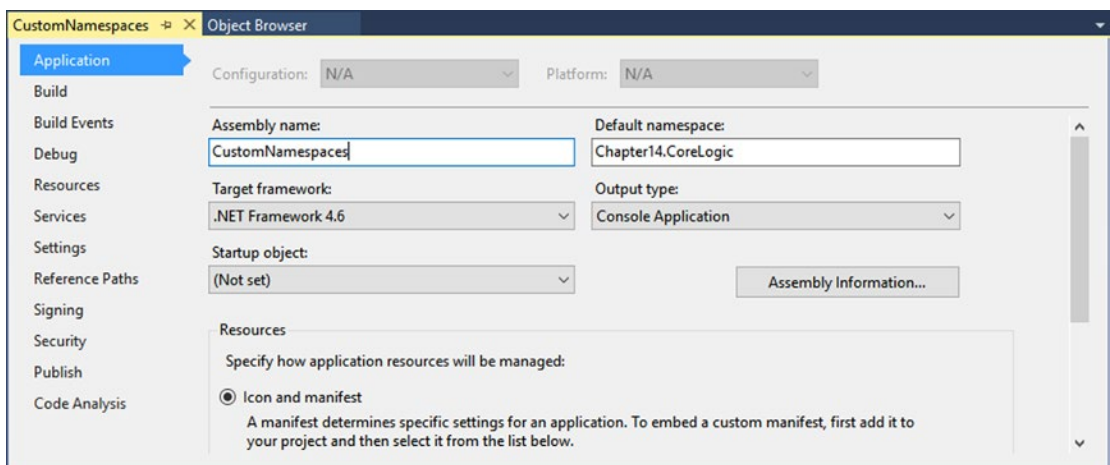

Figure 14-1. Configuring the default namespace

With this update, any new item inserted into the project will be wrapped within the `Chapter14.CoreLogic` namespace (and, obviously, if another namespace wants to use these types, the correct using directive must be applied).

So far, so good. Now that you have seen some details regarding how to package your custom types into well-organized namespaces, let's quickly review the benefits and format of the .NET assembly. After this, you will delve into the details of creating, deploying, and configuring your custom class libraries.

■ **Source Code** The `CustomNamespaces` project is located in the [Chapter 14](#) subdirectory.

The Role of .NET Assemblies

.NET applications are constructed by piecing together any number of *assemblies*. Simply put, an assembly is a versioned, self-describing binary file hosted by the CLR. Now, despite that .NET assemblies have the same file extensions (*.exe or *.dll) as previous Windows binaries, they have little in common with those files under the hood. Thus, to set the stage for the information to come, let's consider some of the benefits provided by the assembly format.

Assemblies Promote Code Reuse

As you have built your Console Application projects over the previous chapters, it might have seemed that *all* the applications' functionality was contained within the executable assembly you were constructing. In reality, your applications were leveraging numerous types contained within the always-accessible .NET code library, `microsoft.dll` (recall that the C# compiler references `microsoft.dll` automatically), and in the case of some examples, `System.Core.dll`.

As you might know, a *code library* (also termed a *class library*) is a *.dll that contains types intended to be used by external applications. When you are creating executable assemblies, you will no doubt be leveraging numerous system-supplied and custom code libraries as you create your application. Do be aware, however, that a code library need not take a *.dll file extension. It is perfectly possible (although certainly not common) for an executable assembly to use types defined within an external executable file. In this light, a referenced *.exe can also be considered a code library.

Regardless of how a code library is packaged, the .NET platform allows you to reuse types in a language-independent manner. For example, you could create a code library in C# and reuse that library in any other .NET programming language. It is possible not only to allocate types across languages but also to derive from them. A base class defined in C# could be extended by a class authored in Visual Basic. Interfaces defined in F# can be implemented by structures defined in C#, and so forth. The point is that when you begin to break apart a single monolithic executable into numerous .NET assemblies, you achieve a *language-neutral* form of code reuse.

Assemblies Establish a Type Boundary

Recall that a type's *fully qualified name* is composed by prefixing the type's namespace (e.g., `System`) to its name (e.g., `Console`). Strictly speaking, however, the assembly in which a type resides further establishes a type's identity. For example, if you have two uniquely named assemblies (say, `MyCars.dll` and `YourCars.dll`) that both define a namespace (`CarLibrary`) containing a class named `SportsCar`, they are considered unique types in the .NET universe.

Assemblies are Versionable Units

.NET assemblies are assigned a four-part numerical version number of the form `<major>.<minor>.<build>.<revision>`. (If you do not explicitly provide a version number, the assembly is automatically assigned a version of 1.0.0.0, given the default Visual Studio project settings.) This number, in conjunction with an optional *public key value*, allows multiple versions of the same assembly to coexist in harmony on a single machine. Formally speaking, assemblies that provide public key information are termed *strongly named*. As you will see in this chapter, by using a strong name, the CLR is able to ensure that the correct version of an assembly is loaded on behalf of the calling client.

Assemblies are Self-Describing

Assemblies are regarded as *self-describing*, in part because they record every external assembly they must have access to in order to function correctly. Thus, if your assembly requires `System.Windows.Forms.dll` and `System.Core.dll`, this will be documented in the assembly's *manifest*. Recall from Chapter 1 that a manifest is a blob of metadata that describes the assembly itself (name, version, required external assemblies, etc.).

In addition to manifest data, an assembly contains metadata that describes the composition (member names, implemented interfaces, base classes, constructors, and so forth) of every contained type. Because an assembly is documented in such detail, the CLR does *not* consult the Windows system registry to resolve its location (quite the radical departure from Microsoft's legacy COM programming model). As you will discover during this chapter, the CLR makes use of an entirely new scheme to resolve the location of external code libraries.

Assemblies are Configurable

Assemblies can be deployed as “private” or “shared.” Private assemblies reside in the same directory (or possibly a subdirectory) as the client application that uses them. Shared assemblies, on the other hand, are libraries intended to be consumed by numerous applications on a single machine and are deployed to a specific directory termed the *global assembly cache*, or *GAC*.

Regardless of how you deploy your assemblies, you are free to author XML-based configuration files. Using these configuration files, you can instruct the CLR to “probe” for assemblies at a specific location, load a specific version of a referenced assembly for a particular client, or consult an arbitrary directory on your local machine, your network location, or a web-based URL. You'll learn a good deal more about XML configuration files throughout this chapter.

Understanding the Format of a .NET Assembly

Now that you've learned about several benefits provided by the .NET assembly, let's shift gears and get a better idea of how an assembly is composed under the hood. Structurally speaking, a .NET assembly (*.dll or *.exe) consists of the following elements:

- A Windows file header
- A CLR file header
- CIL code
- Type metadata
- An assembly manifest
- Optional embedded resources

While the first two elements (the Windows and CLR headers) are blocks of data you can typically always ignore, they do deserve some brief consideration. Here's an overview of each element.

The Windows File Header

The Windows file header establishes the fact that the assembly can be loaded and manipulated by the Windows family of operating systems. This header data also identifies the kind of application (console-based, GUI-based, or *.dll code library) to be hosted by Windows. If you open a .NET assembly using the `dumpbin.exe` utility (via a Windows Command Prompt) and specify the `/headers` flag as so:

```
dumpbin /headers CarLibrary.dll
```

you can view an assembly's Windows header information. Here is the (partial) Windows header information for the `CarLibrary.dll` assembly you will build a bit later in this chapter (if you would like to run `dumpbin.exe` yourself right now, you can specify the name of any *.dll or *.exe you wrote during this book in place of `CarLibrary.dll`):

```
Dump of file CarLibrary.dll
```

```
PE signature found
File Type: DLL
```

FILE HEADER VALUES

```
14C machine (x86)
  3 number of sections
4B37DCD8 time date stamp Sun Dec 27 16:16:56 2011
  0 file pointer to symbol table
  0 number of symbols
  E0 size of optional header
2102 characteristics
      Executable
      32 bit word machine
      DLL
```

OPTIONAL HEADER VALUES

```
10B magic # (PE32)
8.00 linker version
E00 size of code
600 size of initialized data
  0 size of uninitialized data
2CDE entry point (00402CDE)
2000 base of code
4000 base of data
400000 image base (00400000 to 00407FFF)
2000 section alignment
  200 file alignment
4.00 operating system version
0.00 image version
4.00 subsystem version
  0 Win32 version
8000 size of image
  200 size of headers
  0 checksum
  3 subsystem (Windows CUI)
```

```
...
```

Now, remember that the vast majority of .NET programmers will never need to concern themselves with the format of the header data embedded in a .NET assembly. Unless you happen to be building a new .NET language compiler (where you *would* care about such information), you are free to remain blissfully unaware of the grimy details of the header data. Do be aware, however, that this information is used under the covers when Windows loads the binary image into memory.

The CLR File Header

The CLR header is a block of data that all .NET assemblies must support (and do support, courtesy of the C# compiler) to be hosted by the CLR. In a nutshell, this header defines numerous flags that enable the runtime to understand the layout of the managed file. For example, flags exist that identify the location of the metadata and resources within the file, the version of the runtime the assembly was built against, the value of the (optional) public key, and so forth. If you supply the `/clrheader` flag to `dumpbin.exe` like so:

```
dumpbin /clrheader CarLibrary.dll
```

you are presented with the internal CLR header information for a given .NET assembly, as shown here:

```
Dump of file CarLibrary.dll
```

```
File Type: DLL
```

```
clr Header:
```

```

    48 cb
    2.05 runtime version
    2164 [    A74] RVA [size] of MetaData Directory
    1 flags
        IL Only
    0 entry point token
    0 [    0] RVA [size] of Resources Directory
    0 [    0] RVA [size] of StrongNameSignature Directory
    0 [    0] RVA [size] of CodeManagerTable Directory
    0 [    0] RVA [size] of VTableFixups Directory
    0 [    0] RVA [size] of ExportAddressTableJumps Directory
    0 [    0] RVA [size] of ManagedNativeHeader Directory
```

```
Summary
```

```

    2000 .reloc
    2000 .rsrc
    2000 .text
```

Again, as a .NET developer, you will not need to concern yourself with the gory details of an assembly's CLR header information. Just understand that every .NET assembly contains this data, which is used behind the scenes by the .NET runtime as the image data loads into memory. Now turn your attention to some information that is much more useful in your day-to-day programming tasks.

CIL Code, Type Metadata, and the Assembly Manifest

At its core, an assembly contains CIL code, which, as you recall, is a platform- and CPU-agnostic intermediate language. At runtime, the internal CIL is compiled on the fly using a just-in-time (JIT) compiler, according to platform- and CPU-specific instructions. Given this design, .NET assemblies can indeed execute on a variety of architectures, devices, and operating systems. (Although you can live a happy and productive life without understanding the details of the CIL programming language, Chapter 18 offers an introduction to the syntax and semantics of CIL.)

An assembly also contains metadata that completely describes the format of the contained types, as well as the format of external types referenced by this assembly. The .NET runtime uses this metadata to resolve the location of types (and their members) within the binary, lay out types in memory, and facilitate remote method invocations. You'll check out the details of the .NET metadata format in Chapter 15 during your examination of reflection services.

An assembly must also contain an associated *manifest* (also referred to as *assembly metadata*). The manifest documents each *module* within the assembly, establishes the version of the assembly, and also documents any *external* assemblies referenced by the current assembly. As you will see over the course of this chapter, the CLR makes extensive use of an assembly's manifest during the process of locating external assembly references.

Optional Assembly Resources

Finally, a .NET assembly may contain any number of embedded resources, such as application icons, image files, sound clips, or string tables. In fact, the .NET platform supports *satellite assemblies* that contain nothing but localized resources. This can be useful if you want to partition your resources based on a specific culture (English, German, etc.) for the purposes of building international software. The topic of building satellite assemblies is outside the scope of this text; consult the .NET 4.6 Framework documentation for information on satellite assemblies if you are interested.

Building and Consuming Custom Class Library

To begin exploring the world of .NET class libraries, you'll first create a *.dll assembly (named CarLibrary) that contains a small set of public types. To build a code library using Visual Studio, select the Class Library project workspace via the File ► New Project menu option (see Figure 14-2).

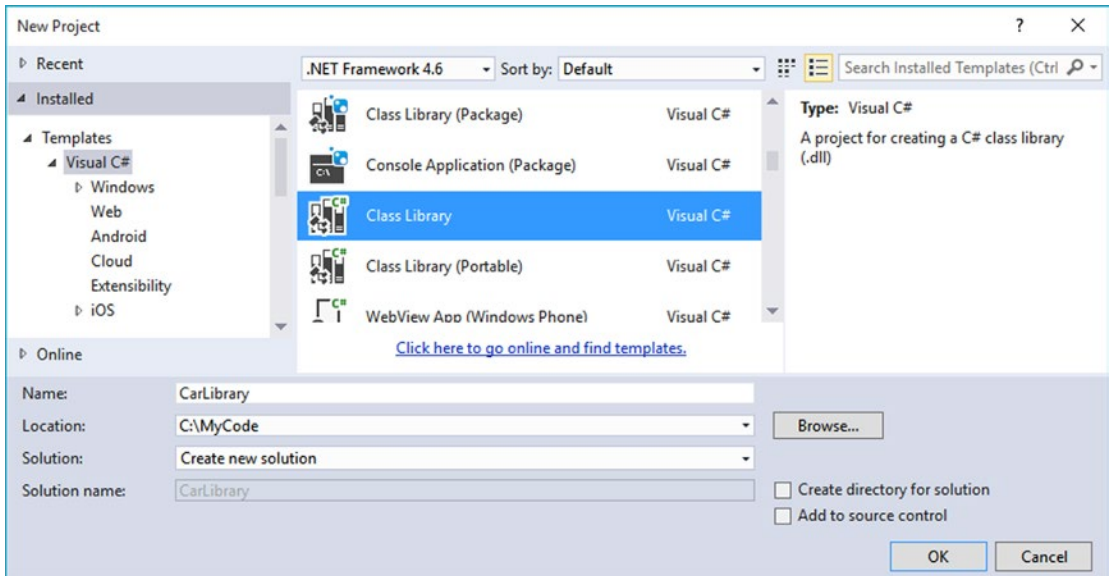

Figure 14-2. Creating a C# class library

The design of your automobile library begins with an abstract base class named `Car` that defines various state data via automatic property syntax. This class also has a single abstract method named `TurboBoost()`, which uses a custom enumeration (`EngineState`) representing the current condition of the car's engine, as shown here:

```
using System;
using System.Collections.Generic;
using System.Linq;
using System.Text;
using System.Threading.Tasks;

namespace CarLibrary
{
    // Represents the state of the engine.
    public enum EngineState
    { engineAlive, engineDead }

    // The abstract base class in the hierarchy.
    public abstract class Car
    {
        public string PetName {get; set;}
        public int CurrentSpeed {get; set;}
        public int MaxSpeed {get; set;}

        protected EngineState egnState = EngineState.engineAlive;
        public EngineState EngineState
        {
            get { return egnState; }
        }
        public abstract void TurboBoost();
    }
}
```

```

public Car(){ }
public Car(string name, int maxSp, int currSp)
{
    PetName = name; MaxSpeed = maxSp; CurrentSpeed = currSp;
}
}
}

```

Now assume you have two direct descendants of the `Car` type named `MiniVan` and `SportsCar`. Each overrides the abstract `TurboBoost()` method by displaying an appropriate message via a Windows Forms message box. Insert a new C# class file into your project, named `DerivedCars.cs`, which contains the following code:

```

using System;
using System.Collections.Generic;
using System.Linq;
using System.Text;
using System.Threading.Tasks;

// Keep reading! This won't compile until you reference a .NET library.
using System.Windows.Forms;

namespace CarLibrary
{
    public class SportsCar : Car
    {
        public SportsCar(){ }
        public SportsCar(string name, int maxSp, int currSp)
            : base (name, maxSp, currSp){ }

        public override void TurboBoost()
        {
            MessageBox.Show("Ramming speed!", "Faster is better...");
        }
    }

    public class MiniVan : Car
    {
        public MiniVan(){ }
        public MiniVan(string name, int maxSp, int currSp)
            : base (name, maxSp, currSp){ }

        public override void TurboBoost()
        {
            // Minivans have poor turbo capabilities!
            engineState = EngineState.engineDead;
            MessageBox.Show("Eek!", "Your engine block exploded!");
        }
    }
}

```

Notice how each subclass implements `TurboBoost()` using the Windows Form's `MessageBox` class, which is defined in the `System.Windows.Forms.dll` assembly. For your assembly to use the types defined within this external assembly, the `CarLibrary` project must add a reference to this assembly via the Add Reference dialog box (see Figure 14-3), which you can access through the Visual Studio Project ► Add Reference menu selection.

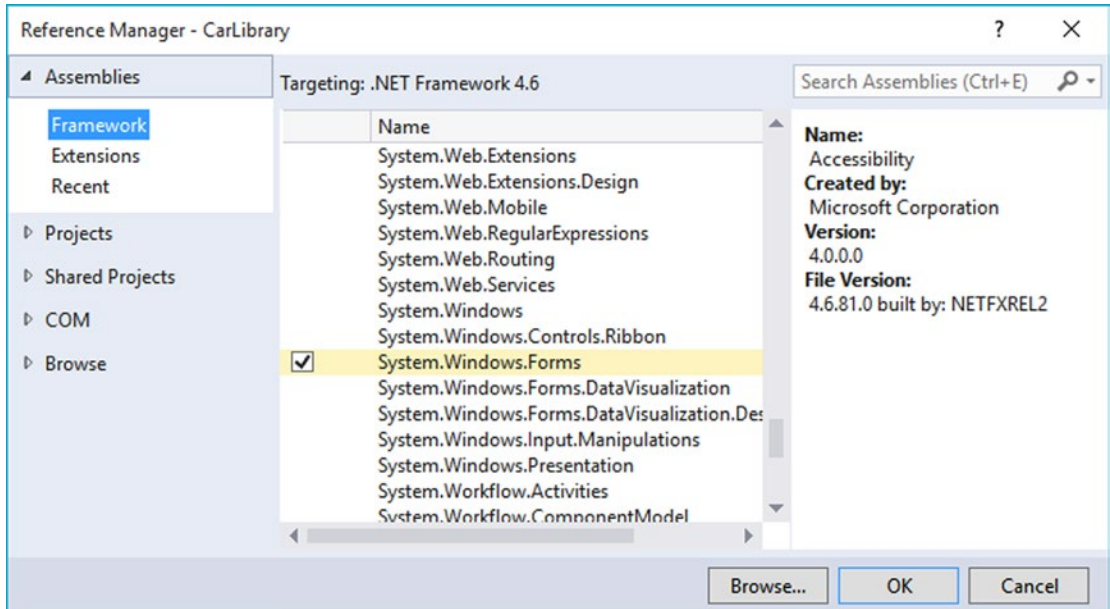

Figure 14-3. Referencing external .NET assemblies using the Add Reference dialog box

It is *really* important to understand that the assemblies displayed in the Framework area of the Add Reference dialog box do not represent every assembly on your machine. The Add Reference dialog box will *not* display your custom libraries, and it does *not* display all libraries located in the GAC (more details later in the chapter). Rather, this dialog box simply presents a list of common assemblies that Visual Studio is preprogrammed to display. When you are building applications that require the use of an assembly not listed within the Add Reference dialog box, you need to click the Browse node to manually navigate to the *.dll or *.exe in question.

■ **Note** Be aware that the Recent section of the Add Reference dialog box keeps a running list of previously referenced assemblies. This can be handy, as many .NET projects tend to use the same core set of external libraries.

Exploring the Manifest

Before using `CarLibrary.dll` from a client application, let's check out how the code library is composed under the hood. Assuming you have compiled this project, load `CarLibrary.dll` into `ildasm.exe` via the File ► Open menu, and navigate to the `\bin\Debug` subdirectory of your `CarLibrary` project. When you are done, you should see your library displayed in the IL disassembler tool (see Figure 14-4).

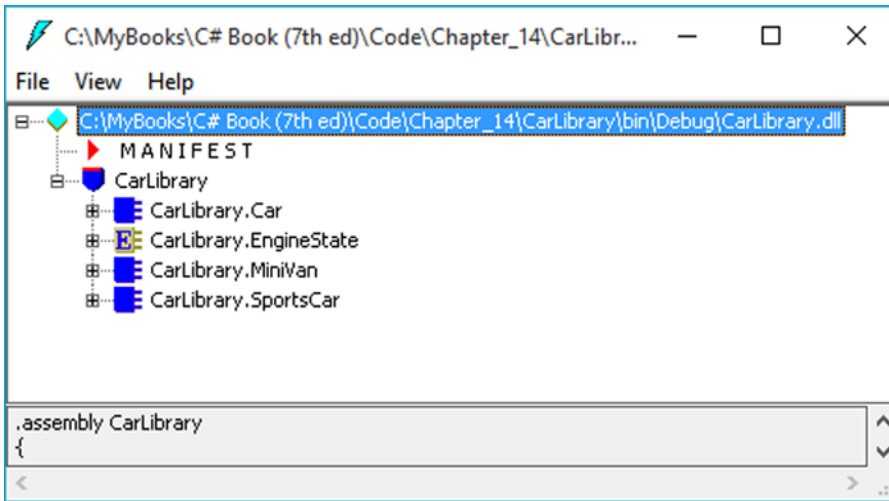

Figure 14-4. *CarLibrary.dll* loaded into *ildasm.exe*

Now, open the manifest of *CarLibrary.dll* by double-clicking the MANIFEST icon. The first code block in a manifest specifies all external assemblies required by the current assembly to function correctly. As you recall, *CarLibrary.dll* made use of types within *mscorlib.dll* and *System.Windows.Forms.dll*, both of which are listed in the manifest using the `.assembly extern` token, as shown here:

```
.assembly extern mscorlib
{
    .publickeytoken = (B7 7A 5C 56 19 34 E0 89 )
    .ver 4:0:0:0
}
.assembly extern System.Windows.Forms
{
    .publickeytoken = (B7 7A 5C 56 19 34 E0 89 )
    .ver 4:0:0:0
}
```

Here, each `.assembly extern` block is qualified by the `.publickeytoken` and `.ver` directives. The `.publickeytoken` instruction is present only if the assembly has been configured with a *strong name* (more details on strong names in the section “Understanding Strong Names,” later in this chapter). The `.ver` token defines (of course) the numerical version identifier of the referenced assembly.

After the external references, you will find a number of `.custom` tokens that identify assembly-level attributes (copyright information, company name, assembly version, etc.). Here is a (very) partial listing of this particular chunk of manifest data:

```
.assembly CarLibrary
{
    .custom instance void ...AssemblyDescriptionAttribute...
    .custom instance void ...AssemblyConfigurationAttribute...
    .custom instance void ...RuntimeCompatibilityAttribute...
    .custom instance void ...TargetFrameworkAttribute...
    .custom instance void ...AssemblyTitleAttribute...
```

```

.custom instance void ...AssemblyTrademarkAttribute...
.custom instance void ...AssemblyCompanyAttribute...
.custom instance void ...AssemblyProductAttribute...
.custom instance void ...AssemblyCopyrightAttribute...
...
.ver 1:0:0:0
}
.module CarLibrary.dll

```

Typically, these settings are established visually using the Properties editor of your current project. Now, switching back to Visual Studio, if you click the Properties icon within the Solution Explorer, you can click the Assembly Information button located on the (automatically selected) Application tab. This will bring up the GUI editor shown in Figure 14-5.

Figure 14-5. Editing assembly information using Visual Studio's Properties editor

When you save your changes, the GUI editor updates your project's `AssemblyInfo.cs` file, which is maintained by Visual Studio and can be viewed by expanding the Properties node of the Solution Explorer (see Figure 14-6).

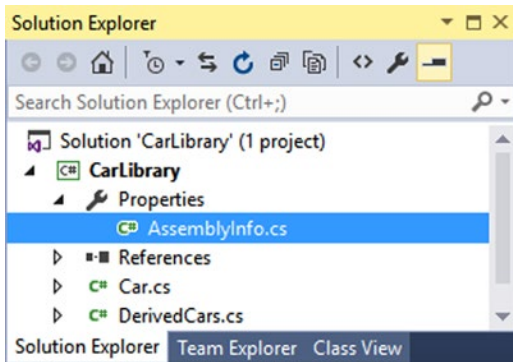

Figure 14-6. The *AssemblyInfo.cs* file is updated as you use the GUI Properties editor

If you view the contents of this C# file, you'll see a number of .NET *attributes* sandwiched between square brackets. Here's an example:

```
[assembly: AssemblyTitle("CarLibrary")]
[assembly: AssemblyDescription("")]
[assembly: AssemblyConfiguration("")]
[assembly: AssemblyCompany("")]
[assembly: AssemblyProduct("CarLibrary")]
[assembly: AssemblyCopyright("Copyright © 2015")]
[assembly: AssemblyTrademark("")]
[assembly: AssemblyCulture("")]
```

Chapter 15 examines the role of attributes in depth, so don't sweat the details at this point. For now, just be aware that a majority of the attributes in *AssemblyInfo.cs* will be used to update the *.custom* token values within an assembly manifest.

Exploring the CIL

Recall that an assembly does not contain platform-specific instructions; rather, it contains platform-agnostic common intermediate language (CIL) instructions. When the .NET runtime loads an assembly into memory, the underlying CIL is compiled (using the JIT compiler) into instructions that can be understood by the target platform. For example, back in *ildasm.exe*, if you double-click the *TurboBoost()* method of the *SportsCar* class, *ildasm.exe* will open a new window showing the CIL tokens that implement this method.

```
.method public hidebysig virtual instance void
  TurboBoost() cil managed
{
  // Code size      18 (0x12)
  .maxstack 8
  IL_0000: nop
  IL_0001: ldstr  "Ramming speed!"
  IL_0006: ldstr  "Faster is better..."
  IL_000b: call  valuetype [System.Windows.Forms]System.Windows.Forms.DialogResult
    [System.Windows.Forms]System.Windows.Forms.MessageBox::Show(string, string)
```

```

IL_0010: pop
IL_0011: ret
} // end of method SportsCar::TurboBoost

```

Again, while most .NET developers don't need to be deeply concerned with the details of CIL on a daily basis, Chapter 18 provides more details on its syntax and semantics. Believe it or not, understanding the grammar of CIL can be helpful when you are building more complex applications that require advanced services, such as runtime construction of assemblies (again, see Chapter 18).

Exploring the Type Metadata

Before you build some applications that use your custom .NET library, if you press the Ctrl+M keystroke combination in `ildasm.exe`, you can see the metadata for each type within the `CarLibrary.dll` assembly (see Figure 14-7).

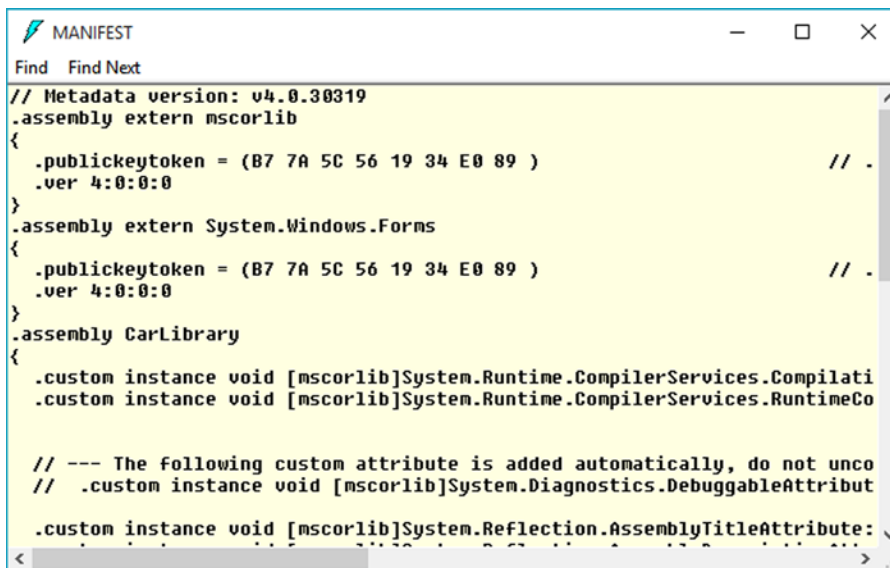

```

MANIFEST
Find Find Next
// Metadata version: v4.0.30319
.assembly extern mscorlib
{
  .publickeytoken = (B7 7A 5C 56 19 34 E0 89 ) // .
  .ver 4:0:0:0
}
.assembly extern System.Windows.Forms
{
  .publickeytoken = (B7 7A 5C 56 19 34 E0 89 ) // .
  .ver 4:0:0:0
}
.assembly CarLibrary
{
  .custom instance void [mscorlib]System.Runtime.CompilerServices.Compilati
  .custom instance void [mscorlib]System.Runtime.CompilerServices.RuntimeCo

  // --- The following custom attribute is added automatically, do not unco
  // .custom instance void [mscorlib]System.Diagnostics.DebuggableAttribut

  .custom instance void [mscorlib]System.Reflection.AssemblyTitleAttribute:

```

Figure 14-7. Type metadata for the types within `CarLibrary.dll`

As explained in the next chapter, an assembly's metadata is an important element of the .NET platform and serves as the backbone for numerous technologies (object serialization, late binding, extendable applications, etc.). In any case, now that you have looked inside the `CarLibrary.dll` assembly, you can build some client applications that use your types.

■ **Source Code** The `CarLibrary` project is located in the Chapter 14 subdirectory.

Building a C# Client Application

Because each of the `CarLibrary` types has been declared using the `public` keyword, other .NET applications are able to use them as well. Recall that you may also define types using the C# `internal` keyword (in fact, this is the default C# access mode). Internal types can be used only by the assembly in which they are defined. External clients can neither see nor create types marked with the `internal` keyword.

To use your library's functionality, create a new C# Console Application project named `CSharpCarClient`. After you have done so, set a reference to `CarLibrary.dll` using the Browse node of the Add Reference dialog box (if you compiled `CarLibrary.dll` using Visual Studio, your assembly is located in the `\bin\Debug` subdirectory of the `CarLibrary` project folder). At this point, you can build your client application to use the external types. Update your initial C# file as follows:

```
using System;
using System.Collections.Generic;
using System.Linq;
using System.Text;
using System.Threading.Tasks;

// Don't forget to import the CarLibrary namespace!
using CarLibrary;

namespace CSharpCarClient
{
    public class Program
    {
        static void Main(string[] args)
        {
            Console.WriteLine("***** C# CarLibrary Client App *****");
            // Make a sports car.
            SportsCar viper = new SportsCar("Viper", 240, 40);
            viper.TurboBoost();

            // Make a minivan.
            MiniVan mv = new MiniVan();
            mv.TurboBoost();

            Console.WriteLine("Done. Press any key to terminate");
            Console.ReadLine();
        }
    }
}
```

This code looks just like the code of the other applications developed thus far in the book. The only point of interest is that the C# client application is now using types defined within a separate custom library. Go ahead and run your program and verify that you see the display of various message boxes.

You might be wondering exactly what happened when you referenced `CarLibrary.dll` using the Add Reference dialog box. If you click the Show All Files button of the Solution Explorer, you will notice that Visual Studio added a copy of the original `CarLibrary.dll` into the `\bin\Debug` folder of the `CSharpCarClient` project folder (see Figure 14-8).

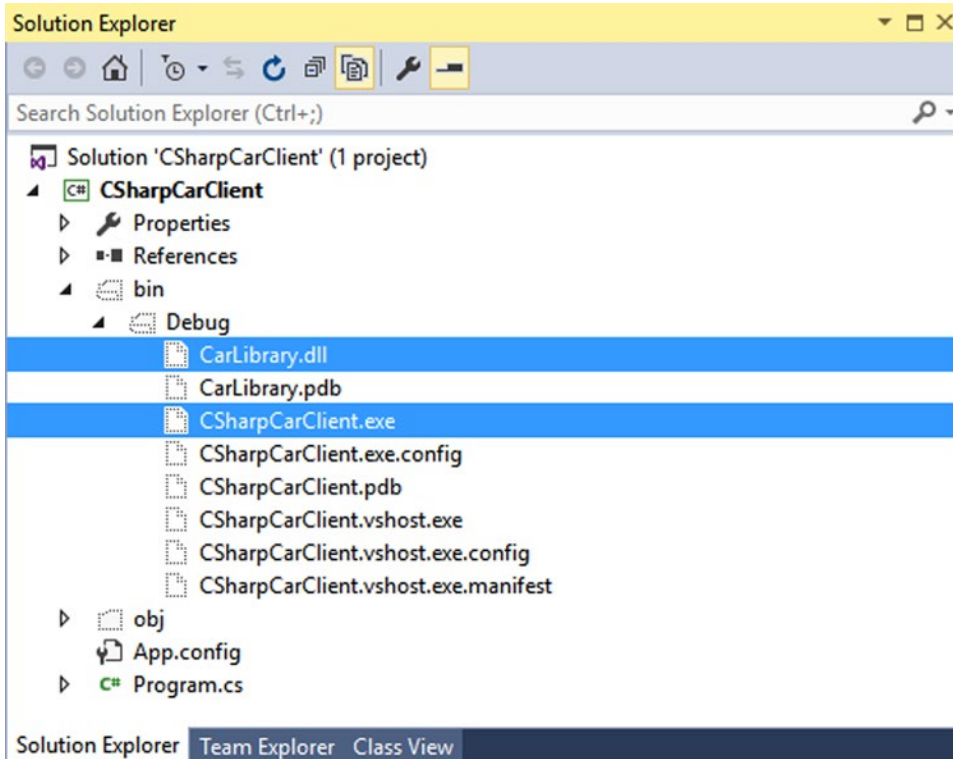

Figure 14-8. Visual Studio copies private assemblies to the client's directory

As explained shortly, `CarLibrary.dll` has been configured as a “private” assembly (which is the automatic behavior for all Visual Studio Class Library projects). When you reference private assemblies in new applications (such as `CSharpCarClient.exe`), the IDE responds by placing a copy of the library in the client application's output directory.

■ **Source Code** The `CSharpCarClient` project is located in the Chapter 14 subdirectory.

Building a Visual Basic Client Application

Recall that the .NET platform allows developers to share compiled code across programming languages. To illustrate the language-agnostic attitude of the .NET platform, let's create another Console Application (`VisualBasicCarClient`), this time using Visual Basic (see Figure 14-9). Once you have created the project, set a reference to `CarLibrary.dll` using the Add Reference dialog box, which can be activated by the Project ► Add Reference menu option.

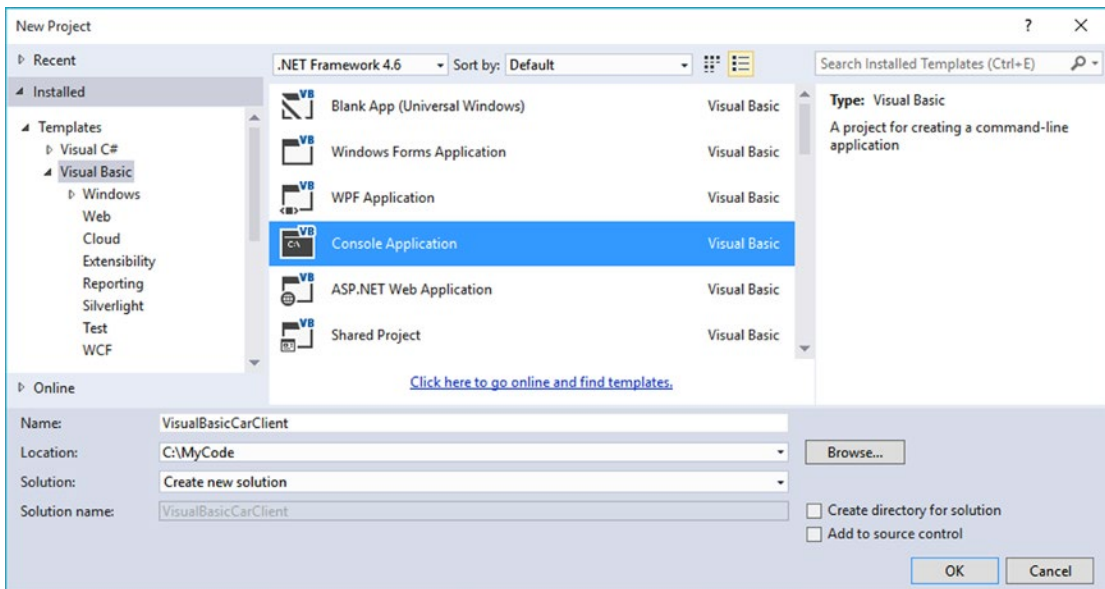

Figure 14-9. Creating a Visual Basic Console Application project

Like C#, Visual Basic allows you to list each namespace used within the current file. However, Visual Basic offers the `Imports` keyword rather than the C# `using` keyword, so add the following `Imports` statement within the `Module1.vb` code file:

```
Imports CarLibrary

Module Module1
    Sub Main()
    End Sub
End Module
```

Notice that the `Main()` method is defined within a Visual Basic module type. In a nutshell, modules are a Visual Basic notation for defining a class that can contain only static methods (much like a C# static class). In any case, to exercise the `MiniVan` and `SportsCar` types using the syntax of Visual Basic, update your `Main()` method as follows:

```
Sub Main()
    Console.WriteLine("***** VB CarLibrary Client App *****")
    ' Local variables are declared using the Dim keyword.
    Dim myMiniVan As New MiniVan()
    myMiniVan.TurboBoost()

    Dim mySportsCar As New SportsCar()
    mySportsCar.TurboBoost()
    Console.ReadLine()
End Sub
```

When you compile and run your application, you will once again find a series of message boxes displayed. Furthermore, this new client application has its own local copy of `CarLibrary.dll` located under the `bin\Debug` folder.

Cross-Language Inheritance in Action

An enticing aspect of .NET development is the notion of *cross-language inheritance*. To illustrate, let's create a new Visual Basic class that derives from `SportsCar` (which was authored using C#). First, add a new class file to your current Visual Basic application (by selecting the Project ► Add Class menu option) named `PerformanceCar.vb`. Update the initial class definition by deriving from the `SportsCar` type using the `Inherits` keyword. Then, override the abstract `TurboBoost()` method using the `Overrides` keyword, like so:

```
Imports CarLibrary

' This VB class is deriving from the C# SportsCar.
Public Class PerformanceCar
    Inherits SportsCar

    Public Overrides Sub TurboBoost()
        Console.WriteLine("Zero to 60 in a cool 4.8 seconds...")
    End Sub
End Class
```

To test this new class type, update the module's `Main()` method as follows:

```
Sub Main()
    ...
    Dim dreamCar As New PerformanceCar()

    ' Use Inherited property.
    dreamCar.PetName = "Hank"
    dreamCar.TurboBoost()
    Console.ReadLine()
End Sub
```

Notice that the `dreamCar` object is able to invoke any public member (such as the `PetName` property) found up the chain of inheritance, regardless of the fact that the base class was defined in a completely different language and in a completely different assembly! The ability to extend classes across assembly boundaries in a language-independent manner is a natural aspect of the .NET development cycle. This makes it easy to use compiled code written by individuals who would rather not build their shared code with C#.

■ **Source Code** The `VisualBasicCarClient` project is located in the [Chapter 14](#) subdirectory.

Understanding Private Assemblies

Technically speaking, the class libraries you've created thus far in this chapter have been deployed as *private assemblies*. Private assemblies must be located within the same directory as the client application that's using them (the *application directory*) or a subdirectory thereof. Recall that when you add a reference to `CarLibrary.dll` while building the `CSharpCarClient.exe` and `VisualBasicCarClient.exe` applications, Visual Studio responded by placing a copy of `CarLibrary.dll` within the client's application directory (at least, after the first compilation).

When a client program uses the types defined within this external assembly, the CLR simply loads the local copy of `CarLibrary.dll`. Because the .NET runtime does not consult the system registry when searching for referenced assemblies, you can relocate the `CSharpCarClient.exe` (or `VisualBasicCarClient.exe`) and `CarLibrary.dll` assemblies to a new location on your machine and run the application (this is often termed *Xcopy deployment*).

Uninstalling (or replicating) an application that makes exclusive use of private assemblies is a no-brainer: simply delete (or copy) the application folder. More important, you do not need to worry that the removal of private assemblies will break any other applications on the machine.

The Identity of a Private Assembly

The full identity of a private assembly consists of the friendly name and numerical version, both of which are recorded in the assembly manifest. The *friendly name* is simply the name of the module that contains the assembly's manifest minus the file extension. For example, if you examine the manifest of the `CarLibrary.dll` assembly, you find the following:

```
.assembly CarLibrary
{
...
.ver 1:0:0:0
}
```

Given the isolated nature of a private assembly, it should make sense that the CLR does not bother to use the version number when resolving its location. The assumption is that private assemblies do not need to have any elaborate version checking, as the client application is the only entity that “knows” of its existence. Because of this, it is possible for a single machine to have multiple copies of the same private assembly in various application directories.

Understanding the Probing Process

The .NET runtime resolves the location of a private assembly using a technique called *probing*, which is much less invasive than it sounds. Probing is the process of mapping an external assembly request to the location of the requested binary file. Strictly speaking, a request to load an assembly may be either *implicit* or *explicit*. An implicit load request occurs when the CLR consults the manifest to resolve the location of an assembly defined using the `.assembly extern` tokens. Here's an example:

```
// An implicit load request.
.assembly extern CarLibrary
{ ... }
```

An explicit load request occurs programmatically using the `Load()` or `LoadFrom()` method of the `System.Reflection.Assembly` class type, typically for the purposes of late binding and dynamic invocation of type members. You'll examine these topics further in Chapter 15, but for now you can see an example of an explicit load request in the following code:

```
// An explicit load request based on a friendly name.
Assembly asm = Assembly.Load("CarLibrary");
```

In either case, the CLR extracts the friendly name of the assembly and begins probing the client's application directory for a file named `CarLibrary.dll`. If this file cannot be located, an attempt is made to locate an executable assembly based on the same friendly name (for example, `CarLibrary.exe`). If neither file can be located in the application directory, the runtime gives up and throws a `FileNotFoundException` exception at runtime.

■ **Note** Technically speaking, if a copy of the requested assembly cannot be found within the client's application directory, the CLR will also attempt to locate a client subdirectory with the same name as the assembly's friendly name (e.g., `C:\MyClient\CarLibrary`). If the requested assembly resides within this subdirectory, the CLR will load the assembly into memory.

Configuring Private Assemblies

While it is possible to deploy a .NET application by simply copying all required assemblies to a single folder on the user's hard drive, you will most likely want to define a number of subdirectories to group related content. For example, assume you have an application directory named `C:\MyApp` that contains `CSharpCarClient.exe`. Under this folder might be a subfolder named `MyLibraries` that contains `CarLibrary.dll`.

Regardless of the intended relationship between these two directories, the CLR will *not* probe the `MyLibraries` subdirectory unless you supply a configuration file. Configuration files contain various XML elements that allow you to influence the probing process. Configuration files must have the same name as the launching application and take a `*.config` file extension, and they must be deployed in the client's application directory. Thus, if you want to create a configuration file for `CSharpCarClient.exe`, it must be named `CSharpCarClient.exe.config` and be located (for this example) in the `C:\MyApp` directory.

To illustrate the process, create a new directory on your `C:` drive named `MyApp` using Windows Explorer. Next, copy `CSharpCarClient.exe` and `CarLibrary.dll` to this new folder, and run the program by double-clicking the executable. Your program should run successfully at this point.

Now, create a new subdirectory in `C:\MyApp` named `MyLibraries` (see Figure 14-10) and move `CarLibrary.dll` to this location.

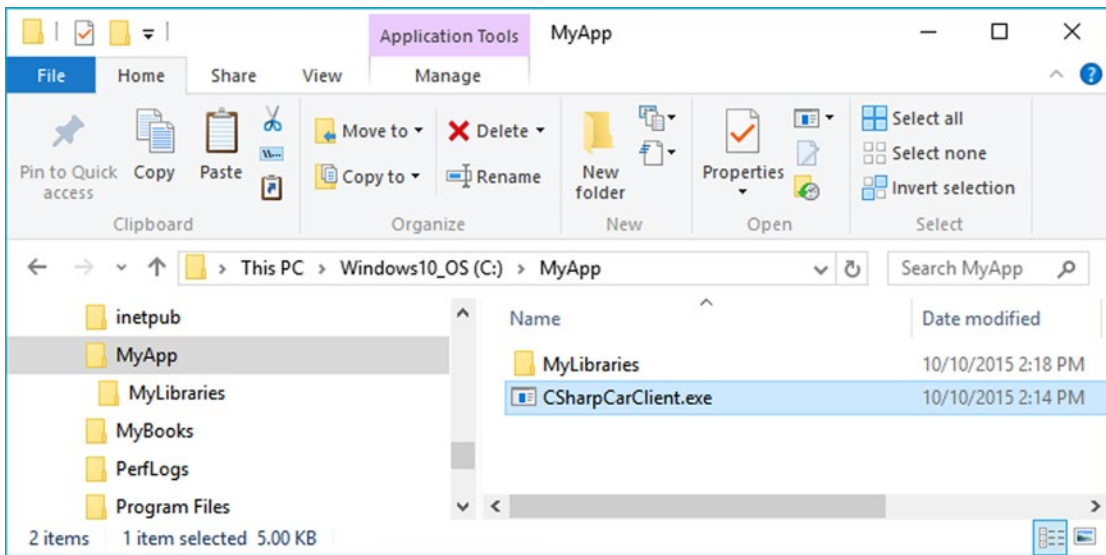

Figure 14-10. *CarLibrary.dll* now resides under the *MyLibraries* subdirectory

Try to run your client program again by double-clicking the executable. Because the CLR could not locate an assembly named *CarLibrary* directly within the application directory, you are presented with a rather nasty unhandled *FileNotFoundException* exception.

To instruct the CLR to probe under the *MyLibraries* subdirectory, create a new configuration file named *CSharpCarClient.exe.config* using any text editor, and save the file in the folder containing the *CSharpCarClient.exe* application, which in this example is *C:\MyApp*. Open this file and enter the following content exactly as shown (be aware that XML is case sensitive!):

```
<configuration>
  <runtime>
    <assemblyBinding xmlns="urn:schemas-microsoft-com:asm.v1">
      <probing privatePath="MyLibraries"/>
    </assemblyBinding>
  </runtime>
</configuration>
```

.NET *.config files always open with a root element named `<configuration>`. The nested `<runtime>` element may specify an `<assemblyBinding>` element, which nests a further element named `<probing>`. The `privatePath` attribute is the key point in this example, as it is used to specify the subdirectories relative to the application directory where the CLR should probe.

Once you've finished creating *CSharpCarClient.exe.config*, run the client by double-clicking the executable in Windows Explorer. You should find that *CSharpCarClient.exe* executes without a hitch (if this is not the case, double-check your *.config file for typos).

Do note that the `<probing>` element does not specify *which* assembly is located under a given subdirectory. In other words, you cannot say, "CarLibrary is located under the MyLibraries subdirectory, but MathLibrary is located under the OtherStuff subdirectory." The `<probing>` element simply instructs the CLR to investigate all specified subdirectories for the requested assembly until the first match is encountered.

■ **Note** Be very aware that the `privatePath` attribute cannot be used to specify an absolute (`C:\SomeFolder\SomeSubFolder`) or relative (`..\SomeFolder\AnotherFolder`) path! If you need to specify a directory outside the client's application directory, you will need to use a completely different XML element named `<codeBase>` (more details on this element later in the chapter).

Multiple subdirectories can be assigned to the `privatePath` attribute using a semicolon-delimited list. You have no need to do so at this time, but here is an example that informs the CLR to consult the `MyLibraries` and `MyLibraries\Tests` client subdirectories:

```
<probing privatePath="MyLibraries;MyLibraries\Tests"/>
```

Next, for testing purposes, change the name of your configuration file (in one way or another) and attempt to run the program once again. The client application should now fail. Remember that `*.config` files must be prefixed with the same name as the related client application. By way of a final test, open your configuration file for editing and capitalize any of the XML elements. Once the file is saved, your client should fail to run once again (as XML is case sensitive).

■ **Note** Understand that the CLR will load the first assembly it finds during the probing process. For example, if the `C:\MyApp` folder did contain a copy of `CarLibrary.dll`, it will be loaded into memory, while the copy in `MyLibraries` is effectively ignored.

The Role of the App.Config File

While you are always able to create XML configuration files by hand using your text editor of choice, Visual Studio allows you to create a configuration file during the development of the client program. By default a new Visual Studio project will contain a configuration file for editing. If you ever need to add one manually, you may do so via the Project ► Add New Item menu option. Notice in Figure 14-11, you have left the name of this file as the suggested `App.config`.

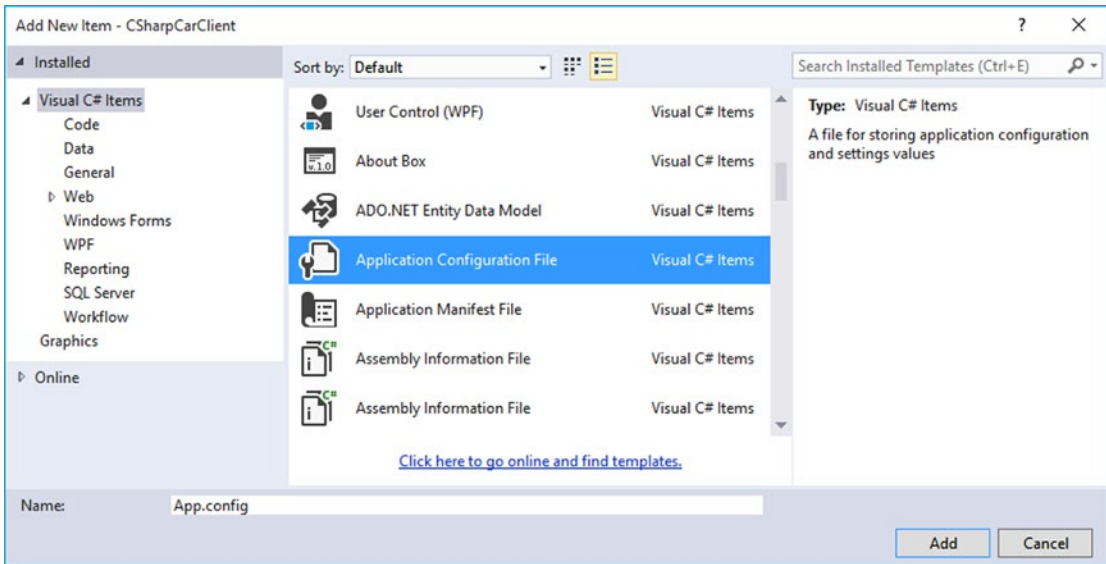

Figure 14-11. Inserting a new XML configuration file

If you open this file for viewing, you'll see a minimal set of instructions, to which you will add additional elements.

```
<?xml version="1.0" encoding="utf-8" ?>
<configuration>
  <startup>
    <supportedRuntime version="v4.0" sku=".NETFramework,Version=v4.6" />
  </startup>
</configuration>
```

Now, here is the cool thing. Each time you compile your project, Visual Studio will automatically copy the data in App.config to a new file in the \bin\Debug directory using the proper naming convention (such as CSharpCarClient.exe.config). However, this behavior will happen only if your configuration file is indeed named App.config; see Figure 14-12.

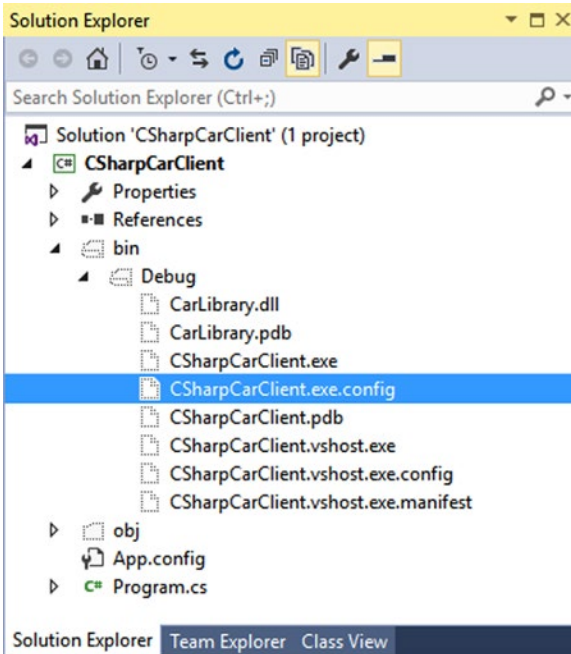

Figure 14-12. The contents of `App.config` will be copied to a correctly named `*.config` in your output directory

Using this approach, all you need to do is maintain `App.config`, and Visual Studio will ensure your application directory contains the latest and greatest configuration data (even if you happen to rename your project).

Understanding Shared Assemblies

Now that you understand how to deploy and configure a private assembly, you can begin to examine the role of a *shared assembly*. Like a private assembly, a shared assembly is a collection of types intended for reuse among projects. The most obvious difference between shared and private assemblies is that a single copy of a shared assembly can be used by several applications on the same machine.

Consider the fact that all the applications created in this text that required access to `mscorlib.dll`. If you were to look in the application directory of each of these clients, you would *not* find a private copy of this .NET assembly. The reason is that `mscorlib.dll` has been deployed as a shared assembly. Clearly, if you need to create a machine-wide class library, this is the way to go.

■ **Note** Deciding whether a code library should be deployed as a private or shared library is yet another design issue to contend with, and this will be based on many project-specific details. As a rule of thumb, when you are building libraries that need to be used by a wide variety of applications, shared assemblies can be quite helpful in that they can be updated to new versions easily (as you will see).

The Global Assembly Cache

As suggested in the previous paragraph, a shared assembly is not deployed within the same directory as the application that uses it. Rather, shared assemblies are installed into the GAC. However, the exact location of the GAC will depend on which versions of the .NET platform you installed on the target computer.

Machines that have not installed .NET 4.0 or higher will find the GAC is located in a subdirectory of your Windows directory named Assembly (e.g., C:\Windows\assembly). These days, you might consider this the “historical GAC,” as it can only contain .NET libraries compiled on versions 1.0, 2.0, 3.0, or 3.5. See Figure 14-13.

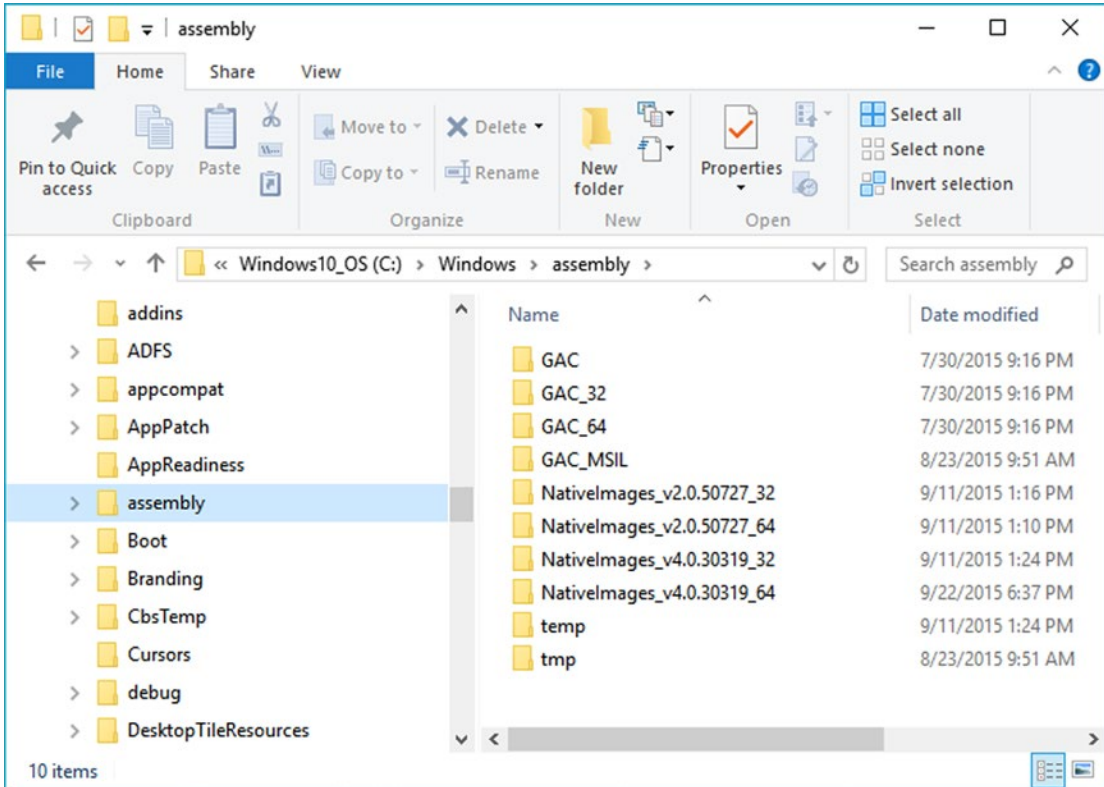

Figure 14-13. The “historical” global assembly cache

■ **Note** You cannot install executable assemblies (*.exe) into the GAC. Only assemblies that take the *.dll file extension can be deployed as a shared assembly.

With the release of .NET 4.0, Microsoft decided to isolate .NET 4.0 and higher libraries to a separate location, specifically C:\Windows\Microsoft.NET\assembly\GAC_MSIL (Figure 14-14).

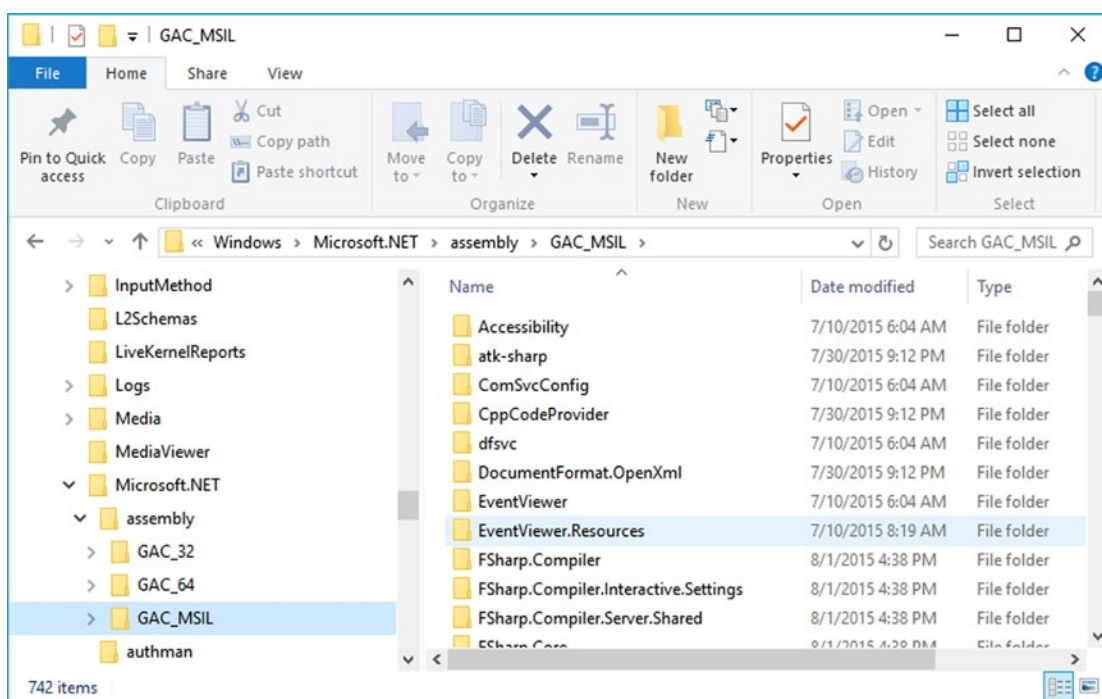

Figure 14-14. The .NET 4.0 and higher global assembly cache

Under this new folder, you will find a set of subdirectories, each of which is named identically to the friendly name of a particular code library (for example, `\System.Windows.Forms`, `\System.Core`, and so on). Beneath a given friendly name folder, you'll find yet another subdirectory that always takes the following naming convention:

```
v4.0_major.minor.build.revision_publicKeyTokenValue
```

The “v4.0” prefix denotes that the library compiled under .NET version 4.0 or higher. That prefix is followed by a single underscore and then the version of the library in question (for example, 1.0.0.0). After a pair of underscores, you'll see another number termed the *publickeytoken value*. As you will see in the next section, the public key value is part of the assembly's “strong name.” Finally, under this folder, you will find a copy of the *.dll in question.

In this book, I am assuming you are building applications using .NET 4.6; therefore, if you install a library to the GAC, it will be installed under `C:\Windows\Microsoft.NET\assembly\GAC_MSIL`. However, be aware that if you were to configure a Class Library project to be compiled using version 3.5 or earlier, you would find shared libraries installed under `C:\Windows\assembly`.

Understanding Strong Names

Before you can deploy an assembly to the GAC, you must assign it a *strong name*, which is used to uniquely identify the publisher of a given .NET binary. Understand that a “publisher” can be an individual programmer (such as yourself), a department within a given company, or an entire company itself.

In some ways, a strong name is the modern-day .NET equivalent of the COM globally unique identifier (GUID) identification scheme. If you have a COM background, you might recall that AppIDs are GUIDs that identify a particular COM application. Unlike COM GUID values (which are nothing more than 128-bit numbers), strong names are based (in part) on two cryptographically related keys (*public keys* and *private keys*), which are much more unique and resistant to tampering than a simple GUID.

Formally, a strong name is composed of a set of related data, much of which is specified using the following assembly-level attributes:

- The friendly name of the assembly (which, you recall, is the name of the assembly minus the file extension)
- The version number of the assembly (assigned using the [AssemblyVersion] attribute)
- The public key value (assigned using the [AssemblyKeyFile] attribute)
- An optional culture identity value for localization purposes (assigned using the [AssemblyCulture] attribute)
- An embedded *digital signature*, created using a hash of the assembly's contents and the private key value

To provide a strong name for an assembly, your first step is to generate public/private key data using the .NET Framework sn.exe utility (which you'll do in a moment). The sn.exe utility generates a file (typically ending with the *.snk [Strong Name Key] file extension) that contains data for two distinct but mathematically related keys, the public key and the private key. Once the C# compiler is made aware of the location of your *.snk file, it will record the full public key value in the assembly manifest using the .publickey token at the time of compilation.

The C# compiler will also generate a hash code based on the contents of the entire assembly (CIL code, metadata, and so forth). As you recall from Chapter 6, a *hash code* is a numerical value that is statistically unique for a fixed input. Thus, if you modify any aspect of a .NET assembly (even a single character in a string literal), the compiler yields a different hash code. This hash code is combined with the private key data within the *.snk file to yield a digital signature embedded within the assembly's CLR header data. Figure 14-15 illustrates the process of strongly naming an assembly.

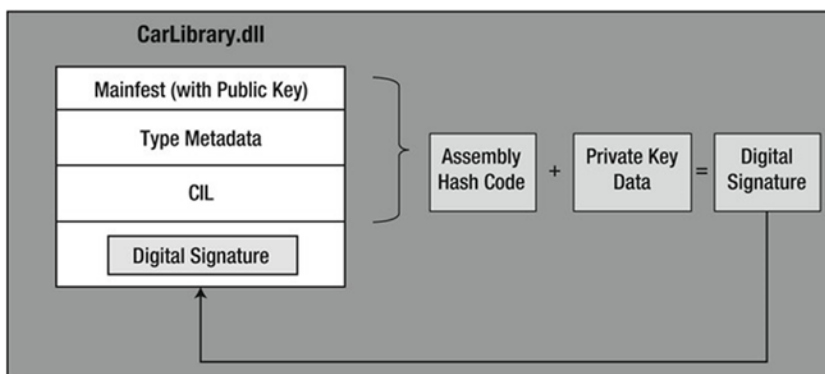

Figure 14-15. At compile time, a digital signature is generated and embedded into the assembly based, in part, on public and private key data

Understand that the actual private key data is not listed anywhere within the manifest but is used only to digitally sign the contents of the assembly (in conjunction with the generated hash code). Again, the whole idea of using public/private key data is to ensure that no two companies, departments, or individuals have the same identity in the .NET universe. In any case, once the process of assigning a strong name is complete, the assembly may be installed into the GAC.

■ **Note** Strong names also provide a level of protection against potential evildoers tampering with your assembly's contents. Given this point, it is considered a .NET best practice to strongly name every assembly (including *.exe assemblies), regardless of whether it is deployed to the GAC.

Generating Strong Names at the Command Line

Let's walk through the process of assigning a strong name to the `CarLibrary` assembly created earlier in this chapter. These days, you will most likely generate the required *.snk file using Visual Studio. However, in the bad old days (circa 2003), the only option for strongly signing an assembly was to do so at the command line. Let's see how to do this.

The first order of business is to generate the required key data using the `sn.exe` utility. Although this tool has numerous command-line options, all you need to concern yourself with for the moment is the `-k` flag, which instructs the tool to generate a new file containing the public/private key information.

Create a new folder on your C drive named `MyTestKeyPair` and change to that directory using the developer command prompt. Next, issue the following command to generate a file named `MyTestKeyPair.snk`:

```
sn -k MyTestKeyPair.snk
```

Now that you have your key data, you need to inform the C# compiler exactly where `MyTestKeyPair.snk` is located. Recall from earlier in this chapter, when you create any new C# project workspace using Visual Studio, one of the initial project files (located under the Properties node of the Solution Explorer) is named `AssemblyInfo.cs`. This file contains a number of attributes that describe the assembly itself. The `[AssemblyKeyFile]` assembly-level attribute can be added to your `AssemblyInfo.cs` file to inform the compiler of the location of a valid *.snk file. Simply specify the path as a string parameter. Here's an example:

```
[assembly: AssemblyKeyFile(@"C:\MyTestKeyPair\MyTestKeyPair.snk")]
```

■ **Note** When you manually specify the `[AssemblyKeyFile]` attribute, Visual Studio will generate a warning informing you to use the `/keyfile` option of `csc.exe` or to establish the key file via the Visual Studio Properties window. You'll use the IDE to do so in just a moment (so feel free to ignore the generated warning).

Because the version of a shared assembly is one aspect of a strong name, selecting a version number for `CarLibrary.dll` is a necessary detail. In the `AssemblyInfo.cs` file, you will find another attribute named `[AssemblyVersion]`. Initially, the value is set to `1.0.0.0`.

```
[assembly: AssemblyVersion("1.0.0.0")]
```

A .NET version number is composed of the four parts (*<major>.<minor>.<build>.<revision>*). While specifying a version number is entirely up to you, you can instruct Visual Studio to automatically increment the build and revision numbers as part of each compilation using the wildcard token, rather than with a specific build and revision value. You have no need to do so for this example; however, consider the following:

```
// Format: <Major number>.<Minor number>.<Build number>.<Revision number>
// Valid values for each part of the version number are between 0 and 65535.
[assembly: AssemblyVersion("1.0.*")]
```

At this point, the C# compiler has all the information needed to generate strong name data (as you are not specifying a unique culture value via the `[AssemblyCulture]` attribute, you “inherit” the culture of your current machine, which in my case would be U.S. English).

Compile your `CarLibrary` code library, open your assembly into `ildasm.exe`, and check the manifest. You will now see that a new `.publickey` tag is used to document the full public key information, while the `.ver` token records the version specified via the `[AssemblyVersion]` attribute (see Figure 14-16).

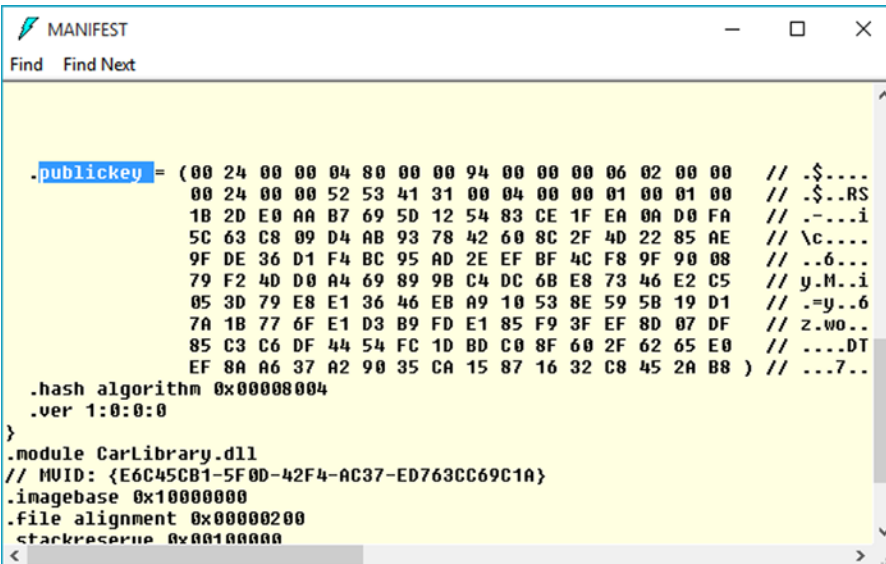

```
MANIFEST
Find Find Next

.publickey = (00 24 00 00 04 80 00 00 94 00 00 00 06 02 00 00 // .$....
             00 24 00 00 52 53 41 31 00 04 00 00 01 00 01 00 // .$..RS
             1B 2D E0 AA B7 69 5D 12 54 83 CE 1F EA 0A D0 FA // -....i
             5C 63 C8 09 D4 AB 93 78 42 60 8C 2F 4D 22 85 AE // \c....
             9F DE 36 D1 F4 BC 95 AD 2E EF BF 4C F8 9F 90 08 // ..6...
             79 F2 4D D0 A4 69 89 9B C4 DC 6B E8 73 46 E2 C5 // y.M..i
             05 3D 79 E8 E1 36 46 EB A9 10 53 8E 59 5B 19 D1 // =y..6
             7A 1B 77 6F E1 D3 B9 FD E1 85 F9 3F EF 8D 07 DF // z.wo..
             85 C3 C6 DF 44 54 FC 1D BD C0 8F 60 2F 62 65 E0 // ...DT
             EF 8A A6 37 A2 90 35 CA 15 87 16 32 C8 45 2A B8 ) // ...7..

.hash algorithm 0x00008004
.ver 1:0:0:0
}
.module CarLibrary.dll
// MVID: {E6C45CB1-5F0D-42F4-AC37-ED763CC69C1A}
.imagebase 0x10000000
.file alignment 0x00000200
.stackreserve 0x00100000
```

Figure 14-16. A strongly named assembly records the public key in the manifest

Great! At this point, you could deploy your shared `CarLibrary.dll` assembly to the GAC. However, remember that these days, .NET developers can use Visual Studio to create strongly named assemblies using a friendly user interface rather than the cryptic `sn.exe` command-line tool. Before seeing how to do so, be sure you delete (or comment out) the following line of code from your `AssemblyInfo.cs` file (assuming you manually added this line during this section of the text):

```
// [assembly: AssemblyKeyFile(@"C:\MyTestKeyPair\MyTestKeyPair.snk")]
```

Generating Strong Names Using Visual Studio

Visual Studio allows you to specify the location of an existing *.snk file using the project's Properties page, as well as generate a new *.snk file. To make a new *.snk file for the CarLibrary project, first double-click the Properties icon of the Solution Explorer and select the Signing tab. Next, select the "Sign the assembly" check box, and choose the <New...> option from the drop-down list (see Figure 14-17).

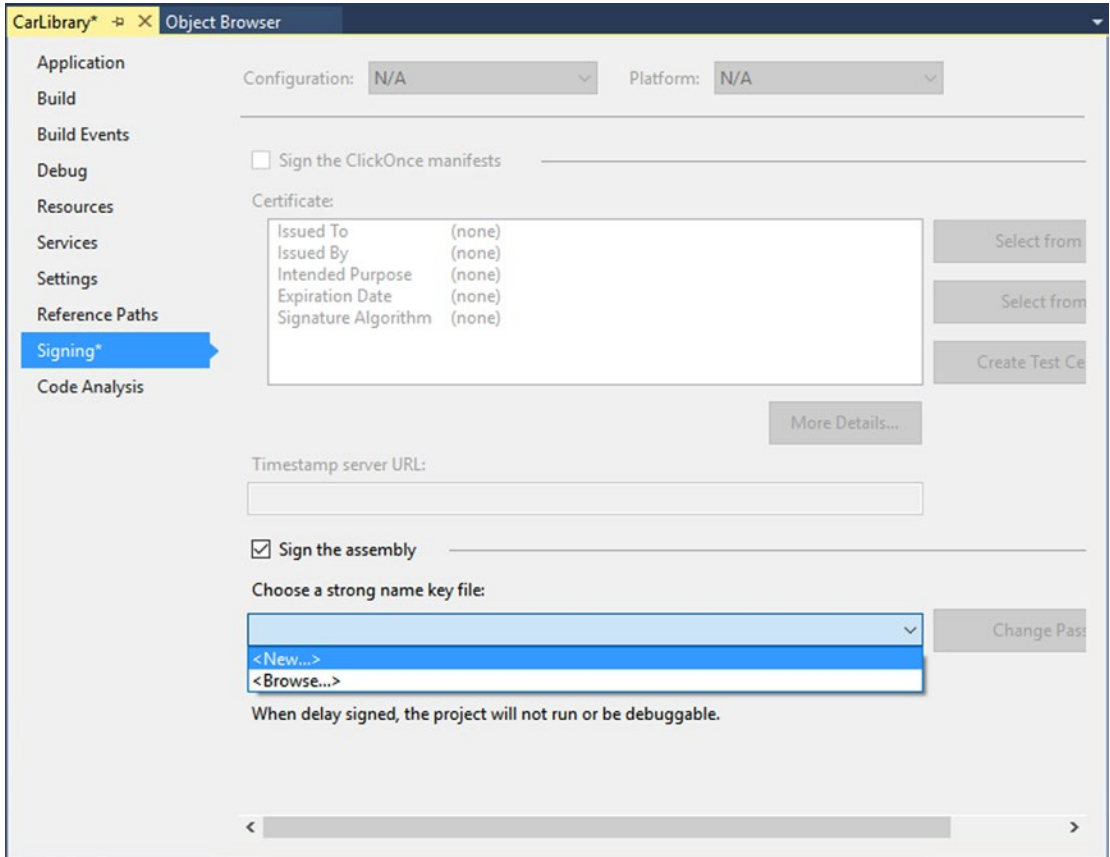

Figure 14-17. Creating a new *.snk file using Visual Studio

After you have done so, you will be asked to provide a name for your new *.snk file (such as myKeyPair.snk), and you'll have the option to password-protect your file (which is not required for this example); see Figure 14-18.

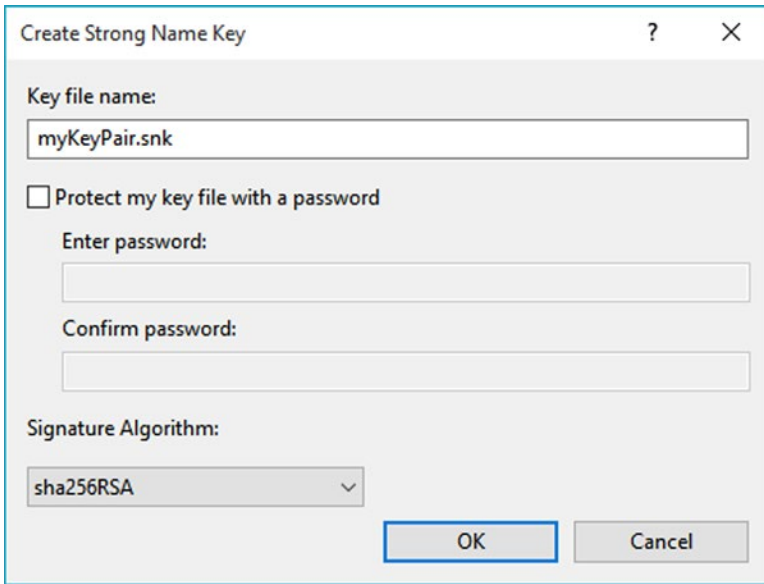

Figure 14-18. Naming the new *.snk file using Visual Studio

At this point, you will see your *.snk file within the Solution Explorer (Figure 14-19). Every time you build your application, this data will be used to assign a proper strong name to the assembly.

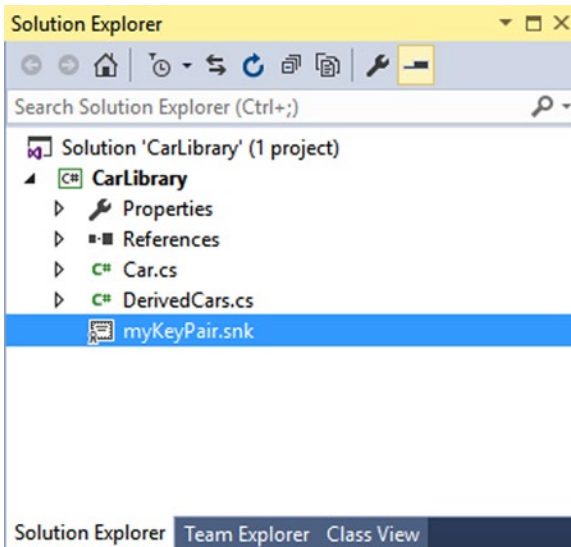

Figure 14-19. Visual Studio will now strongly sign your assembly with each compilation

■ **Note** Recall that the Application tab of the Properties editor provides a button named Assembly Information. When clicked, the button displays a dialog box that allows you to establish numerous assembly-level attributes, including the version number, copyright information, and so forth.

Installing Strongly Named Assemblies to the GAC

The final step is to install the (now strongly named) `CarLibrary.dll` into the GAC. While the preferred way to deploy assemblies to the GAC in a production setting is to create an installer package (using a commercial installer program such as InstallShield), the .NET Framework SDK ships with a command-line tool named `gacutil.exe`, which can be useful for quick tests.

■ **Note** You must have administrator rights to interact with the GAC on your machine. Be sure to run your command window *As Administrator*.

Table 14-1 documents some relevant options of `gacutil.exe` (specify the `/?` flag when you run the program to see each option).

Table 14-1. Various Options of `gacutil.exe`

| Option | Meaning in Life |
|--------|---|
| -i | Installs a strongly named assembly into the GAC |
| -u | Uninstalls an assembly from the GAC |
| -l | Displays the assemblies (or a specific assembly) in the GAC |

To install a strongly named assembly using `gacutil.exe`, first open a command prompt, and then change to the directory containing `CarLibrary.dll`. Here's an example (your path may differ):

```
cd C:\MyCode\CarLibrary\bin\Debug
```

Next, install the library using the `-i` command, like so:

```
gacutil /i CarLibrary.dll
```

After you have done so, you can verify that the library has been deployed by specifying the `-l` command as follows (note that you omit the file extension when using the `-l` command):

```
gacutil /l CarLibrary
```

If all is well, you should see the following output to the Console window (you will find a unique `PublicKeyToken` value, as expected):

The Global Assembly Cache contains the following assemblies:

```
CarLibrary, Version=1.0.0.0, Culture=neutral, PublicKeyToken=33a2bc294331e8b9,
processorArchitecture=MSIL
```

Number of items = 1

Furthermore, if you were to navigate to `C:\Windows\Microsoft.NET\assembly\GAC_MSIL`, you would find a new `CarLibrary` folder with the correct subdirectory structure (see Figure 14-20).

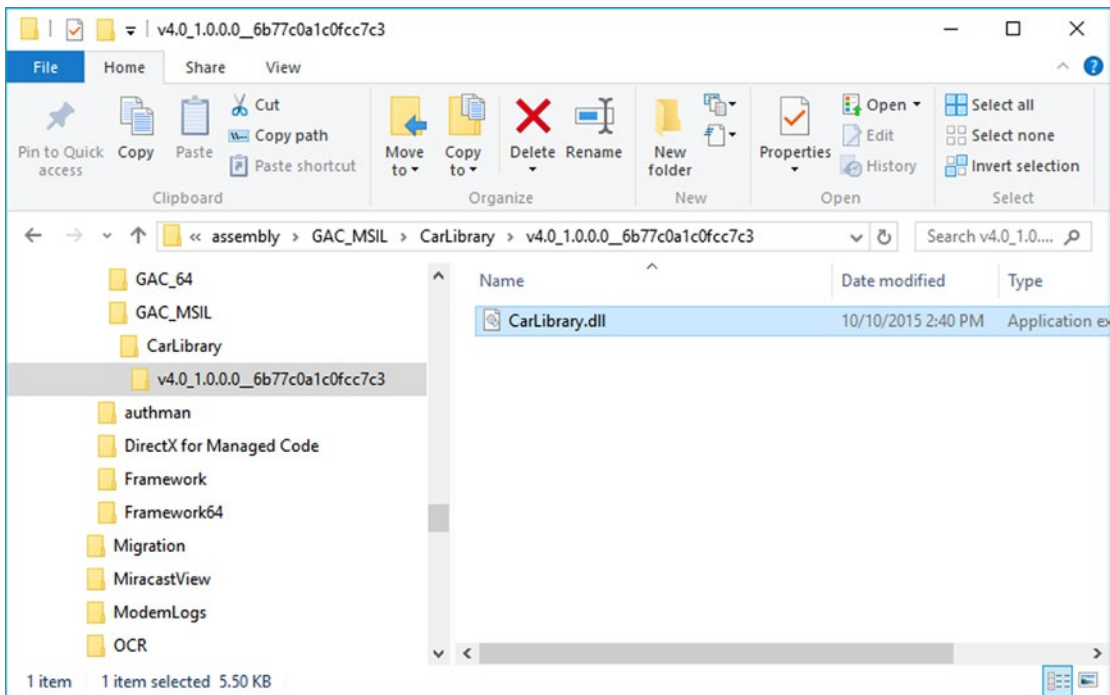

Figure 14-20. The shared `CarLibrary` assembly in the GAC

Consuming a Shared Assembly

When you are building applications that use a shared assembly, the only difference from consuming a private assembly is in how you reference the library using Visual Studio. In reality, there is no difference as far as the tool is concerned—you still use the Add Reference dialog box.

When you need to reference a private assembly, you could use the Browse button to navigate to the correct subdirectory of the GAC. However, you can also simply navigate to the location of the strongly named assembly (such as the `/bin/debug` folder of a class library project) and reference the copy. When Visual Studio finds a strongly named library, it will not copy the library to the output folder of the client application. In any case, Figure 14-21 shows the referenced library.

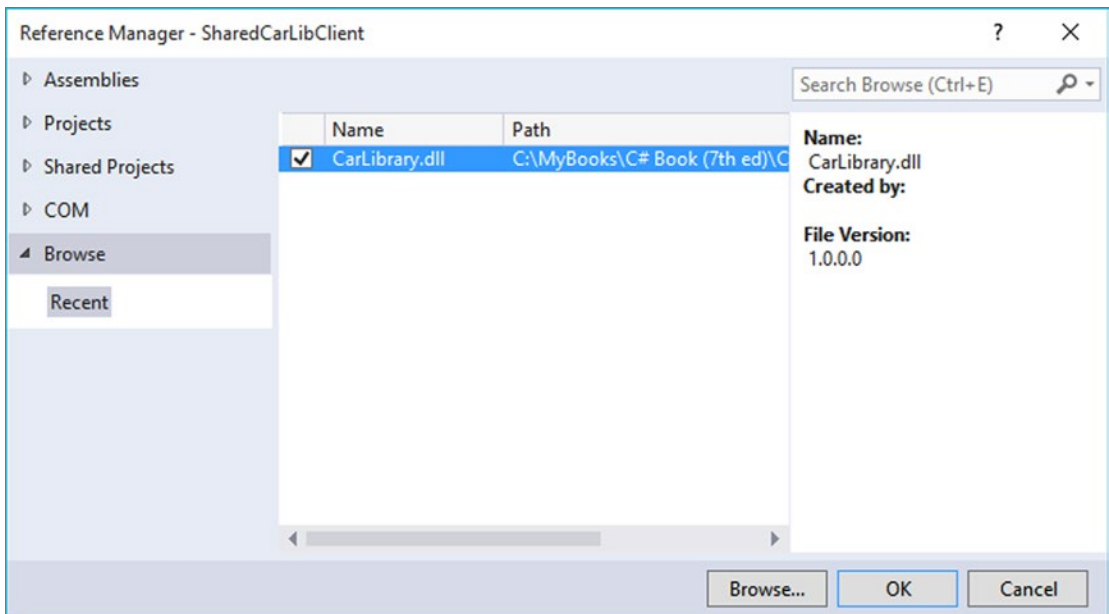

Figure 14-21. Referencing the strongly named, shared *CarLibrary* (version 1.0.0.0) using Visual Studio

To illustrate, create a new C# Console Application project named *SharedCarLibClient* and reference your *CarLibrary.dll* assembly as just described. As you would hope, you can now see an icon in your Solution Explorer's Reference folder. If you select this icon and then view the Properties window (accessible from the Visual Studio View menu), you'll notice that the Copy Local property of the selected *CarLibrary* is now set to False. In any case, author the following test code in your new client application:

```
using System;
using System.Collections.Generic;
using System.Linq;
using System.Text;
using System.Threading.Tasks;

using CarLibrary;

namespace SharedCarLibClient
{
    class Program
    {
        static void Main(string[] args)
        {
            Console.WriteLine("***** Shared Assembly Client *****");
            SportsCar c = new SportsCar();
            c.TurboBoost();
            Console.ReadLine();
        }
    }
}
```

After you have compiled your client application, navigate to the directory that contains `SharedCarLibClient.exe` using Windows Explorer and notice that Visual Studio has *not* copied `CarLibrary.dll` to the client's application directory. When you reference an assembly whose manifest contains a `.publickey` value, Visual Studio assumes the strongly named assembly will be deployed to the GAC and, therefore, does not bother to copy the binary.

Exploring the Manifest of SharedCarLibClient

Recall that when you generate a strong name for an assembly, the entire public key is recorded in the assembly manifest. On a related note, when a client references a strongly named assembly, its manifest records a condensed hash value of the full public key, denoted by the `.publickeytoken` tag. If you open the manifest of `SharedCarLibClient.exe` using `ildasm.exe`, you would find the following (your public key token value will of course differ, as it is computed based on the public key value):

```
.assembly extern CarLibrary
{
  .publickeytoken = (33 A2 BC 29 43 31 E8 B9 )
  .ver 1:0:0:0
}
```

If you compare the value of the public key token recorded in the client manifest with the public key token value shown in the GAC, you will find a dead-on match. Recall that a public key represents one aspect of the strongly named assembly's identity. Given this, the CLR will load only version 1.0.0.0 of an assembly named `CarLibrary` that has a public key that can be hashed down to the value 33A2BC294331E8B9. If the CLR does not find an assembly meeting this description in the GAC (and did not find a private assembly named `CarLibrary` in the client's directory), a `FileNotFoundException` exception is thrown.

■ **Source Code** You can find the `SharedCarLibClient` application in the [Chapter 14](#) subdirectory.

Configuring Shared Assemblies

Like private assemblies, shared assemblies can be configured using a client `*.config` file. Of course, because shared assemblies are deployed to a well-known location (the GAC), you don't use the `<privatePath>` element as you did for private assemblies (although if the client is using both shared and private assemblies, the `<privatePath>` element may still exist in the `*.config` file).

You can use application configuration files in conjunction with shared assemblies whenever you want to instruct the CLR to bind to a *different* version of a specific assembly, effectively bypassing the value recorded in the client's manifest. This can be useful for a number of reasons. For example, imagine that you have shipped version 1.0.0.0 of an assembly and later discover a major bug. One corrective action would be to rebuild the client application to reference the correct version of the bug-free assembly (say, 1.1.0.0) and redistribute the updated client and new library to every target machine.

Another option is to ship the new code library and a `*.config` file that automatically instructs the runtime to bind to the new (bug-free) version. As long as the new version has been installed into the GAC, the original client runs without recompilation, redistribution, or fear of having to update your resume.

Here's another example: you have shipped the first version of a bug-free assembly (1.0.0.0), and after a month or two, you add new functionality to the assembly to yield version 2.0.0.0. Obviously, existing client applications that were compiled against version 1.0.0.0 have no clue about these new types, given that their code base makes no reference to them.

New client applications, however, want to make reference to the new functionality in version 2.0.0.0. Under .NET, you are free to ship version 2.0.0.0 to the target machines and have version 2.0.0.0 run alongside the older version 1.0.0.0. If necessary, existing clients can be dynamically redirected to load version 2.0.0.0 (to gain access to the implementation refinements), using an application configuration file without needing to recompile and redeploy the client application.

Freezing the Current Shared Assembly

To illustrate how to dynamically bind to a specific version of a shared assembly, open Windows Explorer and copy the current version of the compiled `CarLibrary.dll` assembly (1.0.0.0) into a distinct subdirectory (I called mine `CarLibrary Version 1.0.0.0`) to symbolize the freezing of this version (see Figure 14-22).

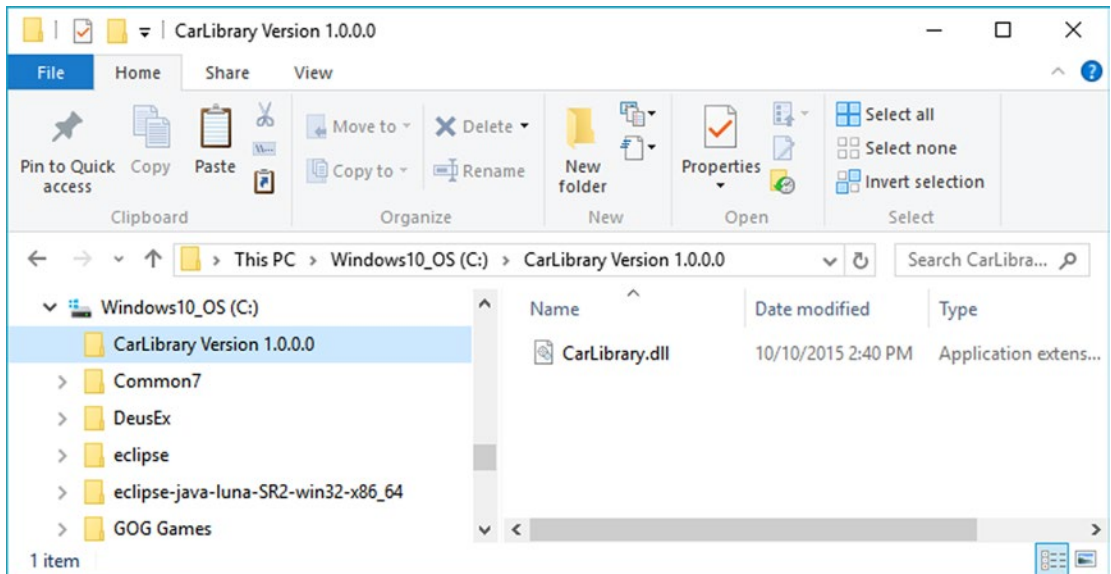

Figure 14-22. Freezing the current version of `CarLibrary.dll`

Building a Shared Assembly Version 2.0.0.0

Now, open your existing `CarLibrary` project and update your code base with a new enum type named `MusicMedia` that defines the following four possible musical devices.

```
// Which type of music player does this car have?
public enum MusicMedia
{
    musicCd,
    musicTape,
    musicRadio,
    musicMp3
}
```

As well, add a new public method to the `Car` type that allows the caller to turn on one of the given media players (be sure to import the `System.Windows.Forms` namespace if necessary), like so:

```
public abstract class Car
{
...
    public void TurnOnRadio(bool musicOn, MusicMedia mm)
    {
        if(musicOn)
            MessageBox.Show(string.Format("Jamming {0}", mm));
        else
            MessageBox.Show("Quiet time...");
    }
}
```

Update the constructors of the `Car` class to display a `MessageBox` that verifies you are indeed using `CarLibrary 2.0.0.0` as follows:

```
public abstract class Car
{
...
    public Car()
    {
        MessageBox.Show("CarLibrary Version 2.0!");
    }
    public Car(string name, int maxSp, int currSp)
    {
        MessageBox.Show("CarLibrary Version 2.0!");
        PetName = name; MaxSpeed = maxSp; CurrentSpeed = currSp;
    }
...
}
```

Last but not least, before you recompile your new library, update the version to be `2.0.0.0`. Recall you can do so in a visual manner by double-clicking the Properties icon of the Solution Explorer and clicking the Assembly Information button on the Application tab. After you do, simply update the Assembly Version number (see Figure 14-23).

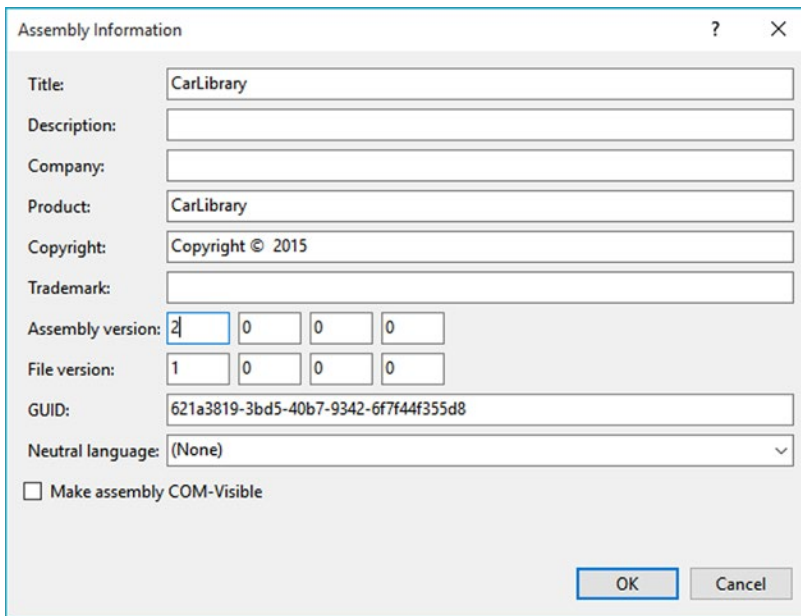

Figure 14-23. Setting the version number of *CarLibrary.dll* to 2.0.0.0

If you look in your project's `\bin\Debug` folder, you'll see that you have a new version of this assembly (2.0.0.0), while version 1.0.0.0 is safe in storage in the `CarLibrary Version 1.0.0.0` directory. Install this new assembly into the 4.0 GAC using `gacutil.exe`, as described earlier in this chapter. Notice that you now have two versions of the same assembly (see Figure 14-24).

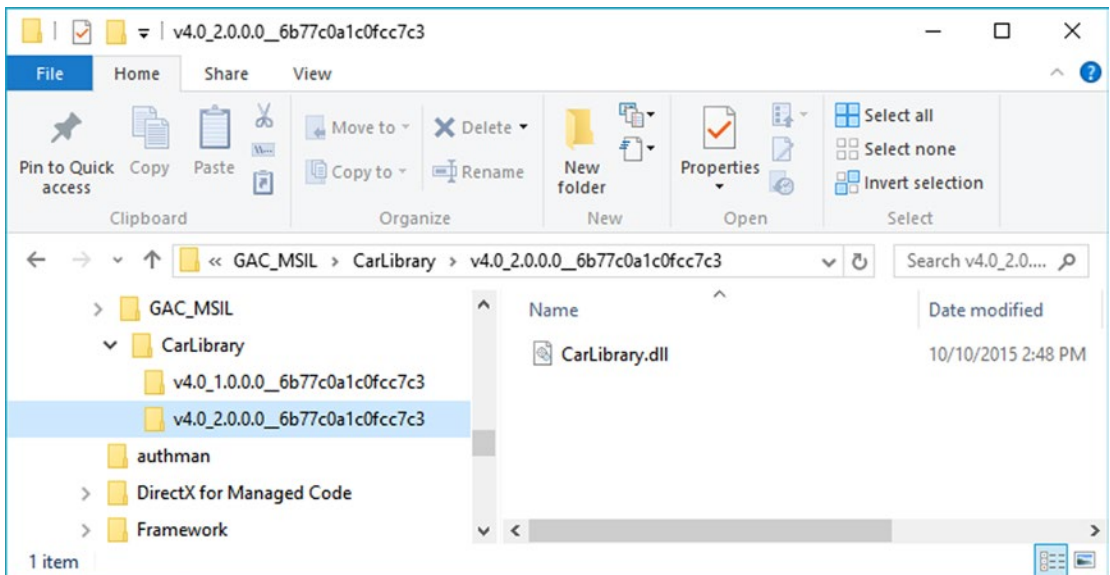

Figure 14-24. Side-by-side execution of a shared assembly

If you run the current `SharedCarLibClient.exe` program by double-clicking the icon in Windows Explorer, you should *not* see the “CarLibrary Version 2.0!” message box appear, as the manifest is specifically requesting version 1.0.0.0. How then can you instruct the CLR to bind to version 2.0.0.0? Glad you asked!

■ **Note** Visual Studio will automatically reset references when you compile your applications! Therefore, if you run your `SharedCarLibClient.exe` application within Visual Studio, it will grab `CarLibrary.dll` version 2.0.0.0! If you accidentally ran your application in this way, simply delete the current `CarLibrary.dll` reference and select version 1.0.0.0 (which I suggested you place in a folder named `CarLibrary Version 1.0.0.0`).

Dynamically Redirecting to Specific Versions of a Shared Assembly

When you want to tell the CLR to load a version of a shared assembly other than the version listed in the manifest, you can build a `*.config` file that contains a `<dependentAssembly>` element. When doing so, you will need to create an `<assemblyIdentity>` subelement that specifies the friendly name of the assembly listed in the client manifest (`CarLibrary`, for this example) and an optional culture attribute (which can be assigned an empty string or omitted altogether if you want to use the default culture for the machine). Moreover, the `<dependentAssembly>` element will define a `<bindingRedirect>` subelement to define the version *currently* in the manifest (via the `oldVersion` attribute) and the version in the GAC to load instead (via the `newVersion` attribute).

Update the current configuration file in the application directory of `SharedCarLibClient` named `SharedCarLibClient.exe.config` that contains the following XML data.

■ **Note** The value of your public key token will be different from what you see in the following markup. To find your public key token value, recall you can open the client into `ildasm.exe`, double-click the MANIFEST icon, and copy the value to your clipboard (just be sure to remove the blank spaces!).

```
<?xml version="1.0" encoding="utf-8" ?>
<configuration>
  <!--Runtime binding info -->
  <runtime>
    <assemblyBinding xmlns="urn:schemas-microsoft-com:asm.v1">
      <dependentAssembly>
        <assemblyIdentity name="CarLibrary"
          publicKeyToken="64ee9364749d8328"
          culture="neutral"/>
        <bindingRedirect oldVersion="1.0.0.0"
          newVersion="2.0.0.0"/>
      </dependentAssembly>
    </assemblyBinding>
  </runtime>
</configuration>
```

Now run the `SharedCarLibClient.exe` program by double-clicking the executable from Windows Explorer. You should see the message that version 2.0.0.0 has loaded.

Multiple `<dependentAssembly>` elements can appear within a client's configuration file. Although there's no need for this example, assume that the manifest of `SharedCarLibClient.exe` also references version 2.5.0.0 of an assembly named `MathLibrary`. If you wanted to redirect to version 3.0.0.0 of `MathLibrary` (in addition to version 2.0.0.0 of `CarLibrary`), the `SharedCarLibClient.exe.config` file would look like the following:

```
<configuration>
  <runtime>
    <assemblyBinding xmlns="urn:schemas-microsoft-com:asm.v1">
      <!-- Controls Binding to CarLibrary -->
      <dependentAssembly>
        <assemblyIdentity name="CarLibrary"
          publicKeyToken="64ee9364749d8328"
          culture=""/>
        <bindingRedirect oldVersion="1.0.0.0" newVersion="2.0.0.0"/>
      </dependentAssembly>

      <!-- Controls Binding to MathLibrary -->
      <dependentAssembly>
        <assemblyIdentity name="MathLibrary"
          publicKeyToken="64ee9364749d8328"
          culture=""/>
        <bindingRedirect oldVersion="2.5.0.0" newVersion="3.0.0.0"/>
      </dependentAssembly>
    </assemblyBinding>
  </runtime>
</configuration>
```

■ **Note** It is possible to specify a range of old version numbers via the `oldVersion` attribute; for example, `<bindingRedirect oldVersion="1.0.0.0-1.2.0.0" newVersion="2.0.0.0"/>` informs the CLR to use version 2.0.0.0 for any older version within the range of 1.0.0.0 to 1.2.0.0.

Understanding Publisher Policy Assemblies

The next configuration issue you'll examine is the role of *publisher policy assemblies*. As you've just seen, `*.config` files can be constructed to bind to a specific version of a shared assembly, thereby bypassing the version recorded in the client manifest. While this is all well and good, imagine you're an administrator who now needs to reconfigure *all* client applications on a given machine to rebind to version 2.0.0.0 of the `CarLibrary.dll` assembly. Given the strict naming convention of a configuration file, you would need to duplicate the same XML content in numerous locations (assuming you are, in fact, aware of the locations of the executables using `CarLibrary!`). Clearly this would be a maintenance nightmare.

Publisher policy allows the publisher of a given assembly (you, your department, your company, or what have you) to ship a binary version of a `*.config` file that is installed into the GAC along with the newest version of the associated assembly. The benefit of this approach is that client application directories do *not* need to contain specific `*.config` files. Rather, the CLR will read the current manifest and attempt to find the requested version in the GAC. However, if the CLR finds a publisher policy assembly, it will read the embedded XML data and perform the requested redirection *at the level of the GAC*.

Publisher policy assemblies are created at the command line using a .NET utility named `al.exe` (the assembly linker). Though this tool provides many options, building a publisher policy assembly requires passing in only the following input parameters:

- The location of the *.config or *.xml file containing the redirecting instructions
- The name of the resulting publisher policy assembly
- The location of the *.snk file used to sign the publisher policy assembly
- The version numbers to assign the publisher policy assembly being constructed

If you wanted to build a publisher policy assembly that controls `CarLibrary.dll`, the command set would be as follows (which must be entered on a single line within the command window):

```
al /link:CarLibraryPolicy.xml /out:policy.1.0.CarLibrary.dll
/keyf:C:\MyKey\myKey.snk /v:1.0.0.0
```

Here, the XML content is contained within a file named `CarLibraryPolicy.xml`. The name of the output file (which must be in the format `policy.<major>.<minor>.assemblyToConfigure`) is specified using the obvious `/out` flag. In addition, note that the name of the file containing the public/private key pair will also need to be supplied via the `/keyf` option. Remember, publisher policy files are shared and, therefore, must have strong names!

Once the `al.exe` tool has executed, the result is a new assembly that can be placed into the GAC to force all clients to bind to version 2.0.0.0 of `CarLibrary.dll`, without the use of a specific client application configuration file. Using this technique, you can design a machine-wide redirection for all applications using a specific version (or range of versions) of an existing assembly.

Disabling Publisher Policy

Now, assume you (as a system administrator) have deployed a publisher policy assembly (and the latest version of the related assembly) to the GAC of a client machine. As luck would have it, nine of the ten affected applications rebind to version 2.0.0.0 without error. However, the remaining client application (for whatever reason) blows up when accessing `CarLibrary.dll 2.0.0.0`. (As we all know, it is next to impossible to build backward-compatible software that works 100 percent of the time.)

In such a case, it is possible to build a configuration file for a specific troubled client that instructs the CLR to *ignore* the presence of any publisher policy files installed in the GAC. The remaining client applications that are happy to consume the newest .NET assembly will simply be redirected via the installed publisher policy assembly. To disable publisher policy on a client-by-client basis, author a (properly named) *.config file that uses the `<publisherPolicy>` element and set the `apply` attribute to `no`. When you do so, the CLR will load the version of the assembly originally listed in the client's manifest.

```
<configuration>
  <runtime>
    <assemblyBinding xmlns="urn:schemas-microsoft-com:asm.v1">
      <publisherPolicy apply="no" />
    </assemblyBinding>
  </runtime>
</configuration>
```

Understanding the <codeBase> Element

Application configuration files can also specify *code bases*. The <codeBase> element can be used to instruct the CLR to probe for dependent assemblies located at arbitrary locations (such as network end points or an arbitrary machine path outside a client's application directory).

If the value assigned to a <codeBase> element is located on a remote machine, the assembly will be downloaded on demand to a specific directory in the GAC termed the *download cache*. Given what you have learned about deploying assemblies to the GAC, it should make sense that assemblies loaded from a <codeBase> element will need to be assigned a strong name (after all, how else could the CLR install remote assemblies to the GAC?). If you are interested, you can view the content of your machine's download cache by supplying the /ldl option to gacutil.exe, like so:

```
gacutil /ldl
```

■ **Note** Technically speaking, the <codeBase> element can be used to probe for assemblies that do not have strong names. However, the assembly's location must be relative to the client's application directory (and, thus, is little more than an alternative to the <privatePath> element).

To see the <codeBase> element in action, create a Console Application project named CodeBaseClient, set a reference to CarLibrary.dll version 2.0.0.0, and update the initial file as follows:

```
using System;
using System.Collections.Generic;
using System.Linq;
using System.Text;
using System.Threading.Tasks;

using CarLibrary;

namespace CodeBaseClient
{
    class Program
    {
        static void Main(string[] args)
        {
            Console.WriteLine("***** Fun with CodeBases *****");
            SportsCar c = new SportsCar();
            Console.WriteLine("Sports car has been allocated.");
            Console.ReadLine();
        }
    }
}
```

Given that CarLibrary.dll has been deployed to the GAC, you are able to run the program as is. However, to illustrate the use of the <codeBase> element, create a new folder under your C: drive (perhaps C:\MyAsms) and place a copy of CarLibrary.dll version 2.0.0.0 into this directory.

Now, add an App.config file (or edit an existing App.config) to the CodeBaseClient project (as explained earlier in this chapter) and author the following XML content (remember that your .publickeytoken value will differ; consult your GAC as required):

```
<configuration>
...
  <runtime>
    <assemblyBinding xmlns="urn:schemas-microsoft-com:asm.v1">
      <dependentAssembly>
        <assemblyIdentity name="CarLibrary" publicKeyToken="33A2BC294331E8B9"
          culture="neutral"/>
        <codeBase version="2.0.0.0" href="file:///C:/MyAsms/CarLibrary.dll" />
      </dependentAssembly>
    </assemblyBinding>
  </runtime>
</configuration>
```

As you can see, the <codeBase> element is nested within the <assemblyIdentity> element, which makes use of the name and publicKeyToken attributes to specify the friendly name and associated publicKeyToken values. The <codeBase> element itself specifies the version and location (via the href property) of the assembly to load. If you were to delete version 2.0.0.0 of CarLibrary.dll from the GAC, this client would still run successfully, as the CLR is able to locate the external assembly under C:\MyAsms.

■ **Note** If you place assemblies at random locations on your development machine, you are in effect re-creating the system registry (and the related DLL hell), given that if you move or rename the folder containing your binaries, the current bind will fail. With that in mind, use <codeBase> with caution.

The <codeBase> element can also be helpful when referencing assemblies located on a remote networked machine. Assume you have permission to access a folder located at <http://www.MySite.com>. To download the remote *.dll to the GAC's download cache on your local machine, you could update the <codeBase> element as follows:

```
<codeBase version="2.0.0.0"
  href="http://www.MySite.com/Assemblies/CarLibrary.dll" />
```

■ **Source Code** You can find the CodeBaseClient application in the Chapter 14 subdirectory.

The System.Configuration Namespace

Currently, all of the *.config files shown in this chapter have made use of well-known XML elements that are read by the CLR to resolve the location of external assemblies. In addition to these recognized elements, it is perfectly permissible for a client configuration file to contain application-specific data that has nothing to do with binding heuristics. Given this, it should come as no surprise that the .NET Framework provides a namespace that allows you to programmatically read the data within a client configuration file.

The `System.Configuration` namespace provides a small set of types you can use to read custom data from a client's `*.config` file. These custom settings must be contained within the scope of an `<appSettings>` element. The `<appSettings>` element contains any number of `<add>` elements that define key-value pairs to be obtained programmatically.

For example, assume you have an `App.config` file for a Console Application project named `AppConfigReaderApp` that defines two application specific values, listed like so:

```
<?xml version="1.0" encoding="utf-8" ?>
<configuration>
  <startup>
    <supportedRuntime version="v4.0" sku=".NETFramework,Version=v4.6" />
  </startup>

  <!-- Custom App settings -->
  <appSettings>
    <add key="TextColor" value="Green" />
    <add key="RepeatCount" value="8" />
  </appSettings>
</configuration>
```

Reading these values for use by the client application is as simple as calling the instance-level `GetValue()` method of the `System.Configuration.AppSettingsReader` type. As shown in the following code, the first parameter to `GetValue()` is the name of the key in the `*.config` file, whereas the second parameter is the underlying type of the key (obtained via the C# `typeof` operator):

```
using System;
using System.Collections.Generic;
using System.Linq;
using System.Text;
using System.Threading.Tasks;

using System.Configuration;

namespace AppConfigReaderApp
{
  class Program
  {
    static void Main(string[] args)
    {
      Console.WriteLine("***** Reading <appSettings> Data *****\n");

      // Get our custom data from the *.config file.
      AppSettingsReader ar = new AppSettingsReader();
      int numBOfTimes = (int)ar.GetValue("RepeatCount", typeof(int));
      string textColor = (string)ar.GetValue("TextColor", typeof(string));

      Console.ForegroundColor =
        (ConsoleColor)Enum.Parse(typeof(ConsoleColor), textColor);
    }
  }
}
```

```
// Now print a message correctly.
for (int i = 0; i < numBOfTimes; i++)
    Console.WriteLine("Howdy!");
Console.ReadLine();
}
}
```

■ **Source Code** You can find the `AppConfigReaderApp` application in the [Chapter 14](#) subdirectory.

The Configuration File Schema Documentation

In this chapter, you were introduced to the role of XML configuration files. Here, you focused on a few settings you can add to the `<runtime>` element that control how the CLR will attempt to locate externally required libraries. As you work on upcoming chapters of this book (and as you move beyond this book and begin to build larger-scale software), you will quickly notice that use of XML configuration files is commonplace.

To be sure, the .NET platform uses `*.config` files in numerous APIs. For example, in [Chapter 25](#), you will see that Windows Communication Foundation (WCF) uses configuration files to establish complex network settings. Later in this text when you examine web development via ASP.NET, you'll quickly note that the `web.config` file contains the same type of instructions as a desktop `App.config` file.

Because a given .NET configuration file can contain a large number of instructions, you should be aware that the entire schema of this XML file is documented in the .NET help system. Specifically, if you do a search for the topic *Configuration File Schema for the .NET Framework* in the help system, you will be given a detailed explanation of each element (see [Figure 14-25](#)).

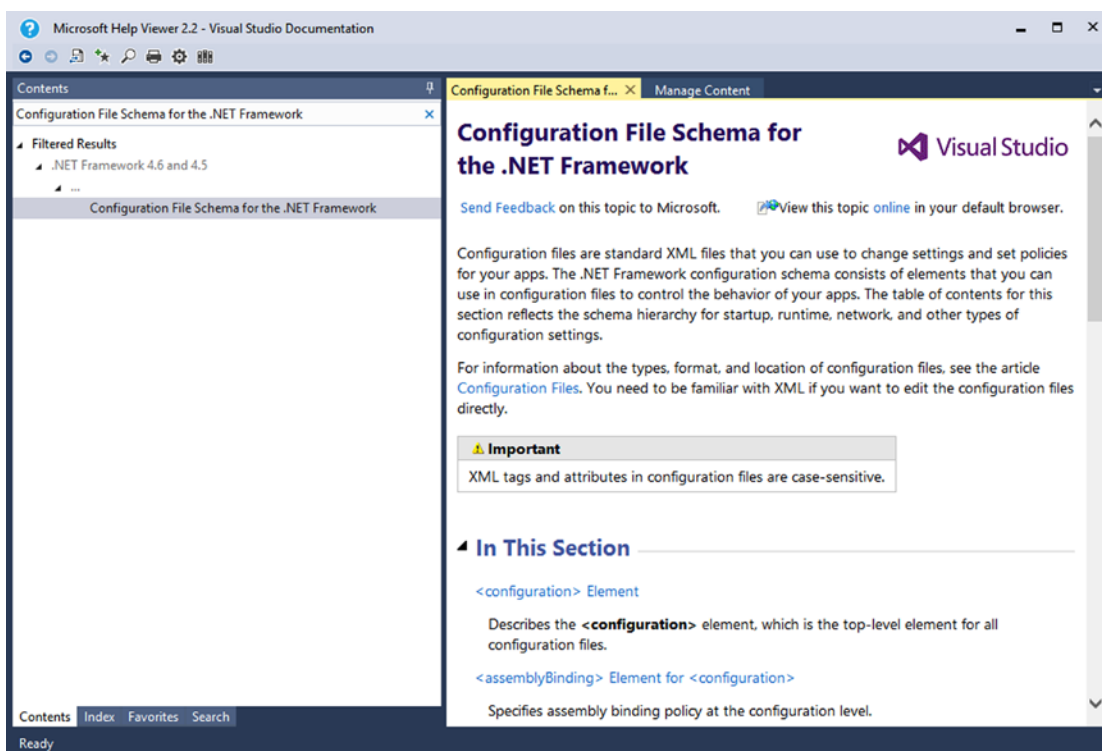

Figure 14-25. XML configuration files are fully documented in the .NET help system

Summary

This chapter examined the role of .NET class libraries (aka .NET *.dlls). As you have seen, class libraries are .NET binaries that contain logic intended to be reused across a variety of projects. Recall that libraries can be deployed in two primary ways, specifically privately or shared. Private assemblies are deployed to the client folder or a subdirectory thereof, provided you have a proper XML configuration file. Shared assemblies are libraries that can be used by any application on the machine and can also be influenced by the settings in a client-side configuration file.

You learned how shared assemblies are marked with a “strong name,” which essentially establishes a unique identify for a library in the eyes of the CLR. As well, you learned about various command-line tools (sn.exe and gacutil.exe) that are used during the development and deployment of shared libraries.

The chapter wrapped up by examining the role of publisher policies and the process of storing and retrieving custom settings using the System.Configuration namespace.

CHAPTER 15



Type Reflection, Late Binding, and Attribute-Based Programming

As shown in Chapter 14, assemblies are the basic unit of deployment in the .NET universe. Using the integrated object browsers of Visual Studio (and numerous other IDEs), you are able to examine the types within a project's referenced set of assemblies. Furthermore, external tools such as `ildasm.exe` allow you to peek into the underlying CIL code, type metadata, and assembly manifest for a given .NET binary. In addition to this design-time investigation of .NET assemblies, you are also able to *programmatically* obtain this same information using the `System.Reflection` namespace. To this end, the first task of this chapter is to define the role of reflection and the necessity of .NET metadata.

The remainder of the chapter examines a number of closely related topics, all of which hinge upon reflection services. For example, you'll learn how a .NET client may employ dynamic loading and late binding to activate types it has no compile-time knowledge of. You'll also learn how to insert custom metadata into your .NET assemblies through the use of system-supplied and custom attributes. To put all of these (seemingly esoteric) topics into perspective, the chapter closes by demonstrating how to build several "snap-in objects" that you can plug into an extendable desktop GUI application.

The Necessity of Type Metadata

The ability to fully describe types (classes, interfaces, structures, enumerations, and delegates) using metadata is a key element of the .NET platform. Numerous .NET technologies, such as Windows Communication Foundation (WCF), and object serialization require the ability to discover the format of types at runtime. Furthermore, cross-language interoperability, numerous compiler services, and an IDE's IntelliSense capabilities all rely on a concrete description of *type*.

Recall that the `ildasm.exe` utility allows you to view an assembly's type metadata using the `Ctrl+M` keyboard option (see Chapter 1). Thus, if you were to open any of the *.dll or *.exe assemblies created over the course of this book (such as the `CarLibrary.dll` created in the Chapter 14) using `ildasm.exe` and press `Ctrl+M`, you would find the relevant type metadata (see Figure 15-1).

```

=====
ScopeName : CarLibrary.dll
GUID      : {ACB1DA4A-82B1-4C6A-A66E-6A36495139A8}
=====
Global Functions
-----
Global Fields
-----
Global MemberRefs
-----
TypeDef #1 (02000002)
-----
  TypeDefName: CarLibrary.EngineState (02000002)
  Flags      : [Public] [AutoLayout] [Class] [Sealed] [AnsiClass] (0000)
  Extends   : 01000010 [TypeRef] System.Enum
  Field #1 (04000001)
  -----
    Field Name: value_ (04000001)
  
```

Figure 15-1. Viewing an assembly's metadata using *ildasm.exe*

As you can see, *ildasm.exe*'s display of .NET type metadata is verbose (the actual binary format is much more compact). In fact, if I were to list the entire metadata description representing the *CarLibrary.dll* assembly, it would span several pages. Given that this act would be a woeful waste of paper, let's just glimpse into some key metadata descriptions of the *CarLibrary.dll* assembly.

■ **Note** Don't be too concerned with the exact syntax of every piece of .NET metadata in the next few sections. The bigger point to absorb is that .NET metadata is very descriptive and lists each internally defined (and externally referenced) type found within a given code base.

Viewing (Partial) Metadata for the EngineState Enumeration

Each type defined within the current assembly is documented using a *TypeDef #n* token (where *TypeDef* is short for *type definition*). If the type being described uses a type defined within a separate .NET assembly, the referenced type is documented using a *TypeRef #n* token (where *TypeRef* is short for *type reference*). A *TypeRef* token is a pointer (if you will) to the referenced type's full metadata definition in an external assembly. In a nutshell, .NET metadata is a set of tables that clearly mark all type definitions (*TypeDefs*) and referenced types (*TypeRefs*), all of which can be viewed using *ildasm.exe*'s metadata window.

As far as *CarLibrary.dll* goes, one *TypeDef* is the metadata description of the *CarLibrary.EngineState* enumeration (your number may differ; *TypeDef* numbering is based on the order in which the C# compiler processes the file).

```
TypeDef #2 (02000003)
```

```
-----
TypDefName: CarLibrary.EngineState (02000003)
Flags      : [Public] [AutoLayout] [Class] [Sealed] [AnsiClass] (00000101)
Extends    : 01000001 [TypeRef] System.Enum
Field #1   (04000006)
```

```
-----
Field Name: value__ (04000006)
Flags      : [Public] [SpecialName] [RTSpecialName] (00000606)
CallCnvtn: [FIELD]
Field type: I4
```

```
Field #2 (04000007)
```

```
-----
Field Name: engineAlive (04000007)
Flags      : [Public] [Static] [Literal] [HasDefault] (00008056)
DefltValue: (I4) 0
CallCnvtn: [FIELD]
Field type: ValueClass CarLibrary.EngineState
```

```
...
```

Here, the `TypDefName` token is used to establish the name of the given type, which in this case is the custom `CarLibrary.EngineState` enum. The `Extends` metadata token is used to document the base type of a given .NET type (in this case, the referenced type, `System.Enum`). Each field of an enumeration is marked using the `Field #n` token. For brevity, I have simply listed the metadata for `CarLibrary.EngineState.engineAlive`.

Viewing (Partial) Metadata for the Car Type

Here is a partial dump of the `Car` class that illustrates the following:

- How fields are defined in terms of .NET metadata
- How methods are documented via .NET metadata
- How an automatic property is represented in .NET metadata

```
TypeDef #3 (02000004)
```

```
-----
TypDefName: CarLibrary.Car (02000004)
Flags : [Public] [AutoLayout] [Class] [Abstract]
       [AnsiClass] [BeforeFieldInit] (00100081)
Extends : 01000002 [TypeRef] System.Object
```

```
...
```

```
Field #2 (0400000a)
```

```
-----
Field Name: <PetName>k__BackingField (0400000a)
Flags      : [Private] (00000001)
CallCnvtn: [FIELD]
Field type: String
```

```
...
```

Method #1 (06000001)

```
-----
MethodName: get_PetName (06000001)
Flags      : [Public] [HideBySig] [ReuseSlot] [SpecialName] (00000886)
RVA       : 0x000020d0
ImplFlags  : [IL] [Managed] (00000000)
CallCnvtn : [DEFAULT]
hasThis
ReturnType: String
No arguments.
```

...

Method #2 (06000002)

```
-----
MethodName: set_PetName (06000002)
Flags      : [Public] [HideBySig] [ReuseSlot] [SpecialName] (00000886)
RVA       : 0x000020e7
ImplFlags  : [IL] [Managed] (00000000)
CallCnvtn : [DEFAULT]
hasThis
ReturnType: Void
1 Arguments
  Argument #1: String
1 Parameters
  (1) ParamToken : (08000001) Name : value flags: [none] (00000000)
```

...

Property #1 (17000001)

```
-----
Prop.Name : PetName (17000001)
Flags     : [none] (00000000)
CallCnvtn : [PROPERTY]
hasThis
ReturnType: String
No arguments.
DefltValue:
Setter   : (06000002) set_PetName
Getter   : (06000001) get_PetName
0 Others
```

...

First, note that the `Car` class metadata marks the type's base class (`System.Object`) and includes various flags that describe how this type was constructed (e.g., `[Public]`, `[Abstract]`, and whatnot). Methods (such as the `Car`'s constructor) are described in regard to their parameters, return value, and name.

Note how an automatic property results in a compiler-generated private backing field (which was named `<PetName>kBackingField`) and two compiler-generated methods (in the case of a read-write property) named, in this example, `get_PetName()` and `set_PetName()`. Finally, the actual property is mapped to the internal get/set methods using the .NET metadata `Getter/Setter` tokens.

Examining a TypeRef

Recall that an assembly's metadata will describe not only the set of internal types (Car, EngineState, etc.) but also any external types the internal types reference. For example, given that CarLibrary.dll has defined two enumerations, you find a TypeRef block for the System.Enum type, as follows:

```
TypeRef #1 (01000001)
```

```
-----
Token:           0x01000001
ResolutionScope: 0x23000001
TypeRefName:     System.Enum
```

Documenting the Defining Assembly

The ildasm.exe metadata window also allows you to view the .NET metadata that describes the assembly itself using the Assembly token. As you can see from the following (partial) listing, information documented within the Assembly table is (surprise, surprise!) the same information that can be viewable via the MANIFEST icon. The following is a partial dump of the manifest of CarLibrary.dll (version 2.0.0.0):

```
Assembly
```

```
-----
Token: 0x20000001
Name : CarLibrary
Public Key : 00 24 00 00 04 80 00 00 // Etc...

Hash Algorithm : 0x00008004
Major Version: 0x00000002
Minor Version: 0x00000000
Build Number: 0x00000000
Revision Number: 0x00000000
Locale: <null>
Flags : [PublicKey] ...
```

Documenting Referenced Assemblies

In addition to the Assembly token and the set of TypeDef and TypeRef blocks, .NET metadata also makes use of AssemblyRef #n tokens to document each external assembly. Given that the CarLibrary.dll makes use of the System.Windows.Forms.MessageBox class, you find an AssemblyRef for the System.Windows.Forms assembly, as shown in the following code:

```
AssemblyRef #2 (23000002)
```

```
-----
Token: 0x23000002
Public Key or Token: b7 7a 5c 56 19 34 e0 89
Name: System.Windows.Forms
Version: 4.0.0.0
Major Version: 0x00000004
```

```

Minor Version: 0x00000000
Build Number: 0x00000000
Revision Number: 0x00000000
Locale: <null>
HashValue Blob:
Flags: [none] (00000000)

```

Documenting String Literals

The final point of interest regarding .NET metadata is the fact that every string literal in your code base is documented under the `User Strings` token.

User Strings

```

-----
70000001 : (11) L"Jamming {0}"
70000019 : (13) L"Quiet time..."
70000035 : (23) L"CarLibrary Version 2.0!"
70000065 : (14) L"Ramming speed!"
70000083 : (19) L"Faster is better..."
700000ab : ( 4) L"Eek!"
700000cd : (27) L"Your engine block exploded!"

```

■ **Note** As illustrated in this last metadata listing, always be aware that all strings are clearly documented in the assembly metadata. This could have huge security consequences if you were to use string literals to capture passwords, credit card numbers, or other sensitive information.

The next question on your mind may be (in the best-case scenario) “How can I leverage this information in my applications?” or (in the worst-case scenario) “Why should I care about metadata?” To address both points of view, allow me to introduce .NET reflection services. Be aware that the usefulness of the topics presented over the pages that follow may be a bit of a head-scratcher until this chapter’s endgame. So hang tight.

■ **Note** You will also find a number of `CustomAttribute` tokens displayed by the `MetaInfo` window, which documents the attributes applied within the code base. You’ll learn about the role of .NET attributes later in this chapter.

Understanding Reflection

In the .NET universe, *reflection* is the process of runtime type discovery. Using reflection services, you are able to programmatically obtain the same metadata information displayed by `ildasm.exe` using a friendly object model. For example, through reflection, you can obtain a list of all types contained within a given `*.dll` or `*.exe` assembly, including the methods, fields, properties, and events defined by a given type. You can also dynamically discover the set of interfaces supported by a given type, the parameters of a method, and other related details (base classes, namespace information, manifest data, and so forth).

Like any namespace, `System.Reflection` (which is defined in `mscorlib.dll`) contains a number of related types. Table 15-1 lists some of the core items you should be familiar with.

Table 15-1. A Sampling of Members of the `System.Reflection` Namespace

| Type | Meaning in Life |
|---------------|--|
| Assembly | This abstract class contains a number of members that allow you to load, investigate, and manipulate an assembly. |
| AssemblyName | This class allows you to discover numerous details behind an assembly's identity (version information, culture information, and so forth). |
| EventInfo | This abstract class holds information for a given event. |
| FieldInfo | This abstract class holds information for a given field. |
| MemberInfo | This is the abstract base class that defines common behaviors for the <code>EventInfo</code> , <code>FieldInfo</code> , <code>MethodInfo</code> , and <code>PropertyInfo</code> types. |
| MethodInfo | This abstract class contains information for a given method. |
| Module | This abstract class allows you to access a given module within a multifile assembly. |
| ParameterInfo | This class holds information for a given parameter. |
| PropertyInfo | This abstract class holds information for a given property. |

To understand how to leverage the `System.Reflection` namespace to programmatically read .NET metadata, you need to first come to terms with the `System.Type` class.

The `System.Type` Class

The `System.Type` class defines a number of members that can be used to examine a type's metadata, a great number of which return types from the `System.Reflection` namespace. For example, `Type.GetMethods()` returns an array of `MethodInfo` objects, `Type.GetFields()` returns an array of `FieldInfo` objects, and so on. The complete set of members exposed by `System.Type` is quite expansive; however, Table 15-2 offers a partial snapshot of the members supported by `System.Type` (see the .NET Framework 4.6 SDK documentation for full details).

Table 15-2. *Select Members of System.Type*

| Member | Meaning in Life |
|-------------------------|--|
| IsAbstract | These properties (among others) allow you to discover a number of basic traits about the <code>Type</code> you are referring to (e.g., if it is an abstract entity, an array, a nested class, and so forth). |
| IsArray | |
| IsClass | |
| IsCOMObject | |
| IsEnum | |
| IsGenericTypeDefinition | |
| IsGenericParameter | |
| IsInterface | |
| IsPrimitive | |
| IsNestedPrivate | |
| IsNestedPublic | |
| IsSealed | |
| IsValueType | |
| GetConstructors() | |
| GetEvents() | |
| GetFields() | |
| GetInterfaces() | |
| GetMembers() | |
| GetMethods() | |
| GetNestedTypes() | |
| GetProperties() | |
| FindMembers() | This method returns a <code>MemberInfo</code> array based on search criteria. |
| GetType() | This static method returns a <code>Type</code> instance given a string name. |
| InvokeMember() | This method allows “late binding” for a given item. You’ll learn about late binding later in this chapter. |

Obtaining a Type Reference Using `System.Object.GetType()`

You can obtain an instance of the `Type` class in a variety of ways. However, the one thing you cannot do is directly create a `Type` object using the `new` keyword, as `Type` is an abstract class. Regarding your first choice, recall that `System.Object` defines a method named `GetType()`, which returns an instance of the `Type` class that represents the metadata for the current object.

```
// Obtain type information using a SportsCar instance.
SportsCar sc = new SportsCar();
Type t = sc.GetType();
```

Obviously, this approach will work only if you have compile-time knowledge of the type you want to reflect over (`SportsCar` in this case) and currently have an instance of the type in memory. Given this restriction, it should make sense that tools such as `ildasm.exe` do not obtain type information by directly calling `System.Object.GetType()` for each type, given the `ildasm.exe` was not compiled against your custom assemblies.

Obtaining a Type Reference Using typeof()

The next way to obtain type information is using the C# `typeof` operator, like so:

```
// Get the type using typeof.
Type t = typeof(SportsCar);
```

Unlike `System.Object.GetType()`, the `typeof` operator is helpful in that you do not need to first create an object instance to extract type information. However, your code base must still have compile-time knowledge of the type you are interested in examining, as `typeof` expects the strongly typed name of the type.

Obtaining a Type Reference Using System.Type.GetType()

To obtain type information in a more flexible manner, you may call the static `GetType()` member of the `System.Type` class and specify the fully qualified string name of the type you are interested in examining. Using this approach, you do *not* need to have compile-time knowledge of the type you are extracting metadata from, given that `Type.GetType()` takes an instance of the omnipresent `System.String`.

■ **Note** When I say you do not need compile-time knowledge when calling `Type.GetType()`, I am referring to the fact that this method can take any string value whatsoever (rather than a strongly typed variable). Of course, you would still need to know the name of the type in a “stringified” format!

The `Type.GetType()` method has been overloaded to allow you to specify two Boolean parameters, one of which controls whether an exception should be thrown if the type cannot be found, and the other of which establishes the case sensitivity of the string. To illustrate, ponder the following:

```
// Obtain type information using the static Type.GetType() method
// (don't throw an exception if SportsCar cannot be found and ignore case).
Type t = Type.GetType("CarLibrary.SportsCar", false, true);
```

In the previous example, notice that the string you are passing into `GetType()` makes no mention of the assembly containing the type. In this case, the assumption is that the type is defined within the currently executing assembly. However, when you want to obtain metadata for a type within an external private assembly, the string parameter is formatted using the type’s fully qualified name, followed by a comma, followed by the friendly name of the assembly containing the type, like so:

```
// Obtain type information for a type within an external assembly.
Type t = Type.GetType("CarLibrary.SportsCar, CarLibrary");
```

As well, do know that the string passed into `Type.GetType()` may specify a plus token (+) to denote a *nested type*. Assume you want to obtain type information for an enumeration (`SpyOptions`) nested within a class named `JamesBondCar`. To do so, you would write the following:

```
// Obtain type information for a nested enumeration
// within the current assembly.
Type t = Type.GetType("CarLibrary.JamesBondCar+SpyOptions");
```

Building a Custom Metadata Viewer

To illustrate the basic process of reflection (and the usefulness of `System.Type`), let's create a Console Application project named `MyTypeViewer`. This program will display details of the methods, properties, fields, and supported interfaces (in addition to some other points of interest) for any type within `mscorlib.dll` (recall all .NET applications have automatic access to this core framework class library) or a type within `MyTypeViewer` itself. Once the application has been created, be sure to import the `System.Reflection` namespace.

```
// Need to import this namespace to do any reflection!
using System.Reflection;
```

Reflecting on Methods

The `Program` class will be updated to define a number of static methods, each of which takes a single `System.Type` parameter and returns `void`. First you have `ListMethods()`, which (as you might guess) prints the name of each method defined by the incoming type. Notice how `Type.GetMethods()` returns an array of `System.Reflection.MethodInfo` objects, which can be enumerated over using a standard `foreach` loop, as follows:

```
// Display method names of type.
static void ListMethods(Type t)
{
    Console.WriteLine("***** Methods *****");
    MethodInfo[] mi = t.GetMethods();
    foreach(MethodInfo m in mi)
        Console.WriteLine("->{0}", m.Name);
    Console.WriteLine();
}
```

Here, you are simply printing the name of the method using the `MethodInfo.Name` property. As you might guess, `MethodInfo` has many additional members that allow you to determine whether the method is static, virtual, generic, or abstract. As well, the `MethodInfo` type allows you to obtain the method's return value and parameter set. You'll spruce up the implementation of `ListMethods()` in just a bit.

If you wanted, you could also build a fitting LINQ query to enumerate the names of each method. Recall from Chapter 12, LINQ to Objects allows you to build strongly typed queries that can be applied to in-memory object collections. As a good rule of thumb, whenever you find blocks of looping or decision programming logic, you could make use of a related LINQ query. For example, you could rewrite the previous method as so:

```
static void ListMethods(Type t)
{
    Console.WriteLine("***** Methods *****");
    var methodNames = from n in t.GetMethods() select n.Name;
    foreach (var name in methodNames)
        Console.WriteLine("->{0}", name);
    Console.WriteLine();
}
```

Reflecting on Fields and Properties

The implementation of `ListFields()` is similar. The only notable difference is the call to `Type.GetFields()` and the resulting `FieldInfo` array. Again, to keep things simple, you are printing out only the name of each field using a LINQ query.

```
// Display field names of type.
static void ListFields(Type t)
{
    Console.WriteLine("***** Fields *****");
    var fieldNames = from f in t.GetFields() select f.Name;
    foreach (var name in fieldNames)
        Console.WriteLine("->{0}", name);
    Console.WriteLine();
}
```

The logic to display a type's properties is similar.

```
// Display property names of type.
static void ListProps(Type t)
{
    Console.WriteLine("***** Properties *****");
    var propNames = from p in t.GetProperties() select p.Name;
    foreach (var name in propNames)
        Console.WriteLine("->{0}", name);
    Console.WriteLine();
}
```

Reflecting on Implemented Interfaces

Next, you will author a method named `ListInterfaces()` that will print the names of any interfaces supported on the incoming type. The only point of interest here is that the call to `GetInterfaces()` returns an array of `System.Type`! This should make sense given that interfaces are, indeed, types.

```
// Display implemented interfaces.
static void ListInterfaces(Type t)
{
    Console.WriteLine("***** Interfaces *****");
    var ifaces = from i in t.GetInterfaces() select i;
    foreach (Type i in ifaces)
        Console.WriteLine("->{0}", i.Name);
}
```

■ **Note** Be aware that a majority of the “get” methods of `System.Type` (`GetMethods()`, `GetInterfaces()`, etc.) have been overloaded to allow you to specify values from the `BindingFlags` enumeration. This provides a greater level of control on exactly what should be searched for (e.g., only static members, only public members, include private members, etc.). Consult the .NET Framework 4.6 SDK documentation for details.

Displaying Various Odds and Ends

Last but not least, you have one final helper method that will simply display various statistics (indicating whether the type is generic, what the base class is, whether the type is sealed, and so forth) regarding the incoming type.

```
// Just for good measure.
static void ListVariousStats(Type t)
{
    Console.WriteLine("***** Various Statistics *****");
    Console.WriteLine("Base class is: {0}", t.BaseType);
    Console.WriteLine("Is type abstract? {0}", t.IsAbstract);
    Console.WriteLine("Is type sealed? {0}", t.IsSealed);
    Console.WriteLine("Is type generic? {0}", t.IsGenericTypeDefinition);
    Console.WriteLine("Is type a class type? {0}", t.IsClass);
    Console.WriteLine();
}
```

Implementing Main()

The `Main()` method of the `Program` class prompts the user for the fully qualified name of a type. Once you obtain this string data, you pass it into the `Type.GetType()` method and send the extracted `System.Type` into each of your helper methods. This process repeats until the user enters **Q** to terminate the application.

```
static void Main(string[] args)
{
    Console.WriteLine("***** Welcome to MyTypeViewer *****");
    string typeName = "";

    do
    {
        Console.WriteLine("\nEnter a type name to evaluate");
        Console.Write("or enter Q to quit: ");

        // Get name of type.
        typeName = Console.ReadLine();

        // Does user want to quit?
        if (typeName.ToUpper() == "Q")
        {
            break;
        }

        // Try to display type.
        try
        {
            Type t = Type.GetType(typeName);
            Console.WriteLine("");
            ListVariousStats(t);
            ListFields(t);
            ListProps(t);
        }
    }
}
```

```

        ListMethods(t);
        ListInterfaces(t);
    }
    catch
    {
        Console.WriteLine("Sorry, can't find type");
    }
} while (true);
}

```

At this point, `MyTypeViewer.exe` is ready to take for a test-drive. For example, run your application and enter the following fully qualified names (be aware that the manner in which you invoked `Type.GetType()` requires case-sensitive string names):

- `System.Int32`
- `System.Collections.ArrayList`
- `System.Threading.Thread`
- `System.Void`
- `System.IO.BinaryWriter`
- `System.Math`
- `System.Console`
- `MyTypeViewer.Program`

For example, here is some partial output when specifying `System.Math`:

```
***** Welcome to MyTypeViewer *****
```

```
Enter a type name to evaluate
or enter Q to quit: System.Math
```

```
***** Various Statistics *****
```

```
Base class is: System.Object
Is type abstract? True
Is type sealed? True
Is type generic? False
Is type a class type? True
```

```
***** Fields *****
```

```
->PI
->E
```

```
***** Properties *****
```

```
***** Methods *****
```

```
->Acos
->Asin
->Atan
```

```
->Atan2
->Ceiling
->Ceiling
->Cos
...
```

Reflecting on Generic Types

When you call `Type.GetType()` to obtain metadata descriptions of generic types, you must make use of a special syntax involving a “back tick” character (```) followed by a numerical value that represents the number of type parameters the type supports. For example, if you want to print out the metadata description of `System.Collections.Generic.List<T>`, you would need to pass the following string into your application:

```
System.Collections.Generic.List`1
```

Here, you are using the numerical value of `1`, given that `List<T>` has only one type parameter. However, if you want to reflect over `Dictionary<TKey, TValue>`, you would supply the value `2`, like so:

```
System.Collections.Generic.Dictionary`2
```

Reflecting on Method Parameters and Return Values

So far, so good! Let’s make a minor enhancement to the current application. Specifically, you will update the `ListMethods()` helper function to list not only the name of a given method but also the return type and incoming parameter types. The `MethodInfo` type provides the `ReturnType` property and `GetParameters()` method for these tasks. In the following modified code, notice that you are building a string that contains the type and name of each parameter using a nested `foreach` loop (without the use of LINQ):

```
static void ListMethods(Type t)
{
    Console.WriteLine("***** Methods *****");
    MethodInfo[] mi = t.GetMethods();
    foreach (MethodInfo m in mi)
    {
        // Get return type.
        string retVal = m.ReturnType.FullName;
        string paramInfo = "( ";
        // Get params.
        foreach (ParameterInfo pi in m.GetParameters())
        {
            paramInfo += string.Format("{0} {1} ", pi.ParameterType, pi.Name);
        }
        paramInfo += " )";

        // Now display the basic method sig.
        Console.WriteLine("->{0} {1} {2}", retVal, m.Name, paramInfo);
    }
    Console.WriteLine();
}
```

If you now run this updated application, you will find that the methods of a given type are much more detailed. If you enter your good friend `System.Object` as input to the program, the following methods will display:

```
***** Methods *****
->System.String ToString ( )
->System.Boolean Equals ( System.Object obj )
->System.Boolean Equals ( System.Object objA System.Object objB )
->System.Boolean ReferenceEquals ( System.Object objA System.Object objB )
->System.Int32 GetHashCode ( )
->System.Type GetType ( )
```

The current implementation of `ListMethods()` is helpful, in that you can directly investigate each parameter and method return type using the `System.Reflection` object model. As an extreme shortcut, be aware that all of the `XXXInfo` types (`MethodInfo`, `PropertyInfo`, `EventInfo`, etc.) have overridden `ToString()` to display the signature of the item requested. Thus, you could also implement `ListMethods()` as follows (once again using LINQ, where you simply select all `MethodInfo` objects, rather than only the `Name` values):

```
static void ListMethods(Type t)
{
    Console.WriteLine("***** Methods *****");
    var methodNames = from n in t.GetMethods() select n;
    foreach (var name in methodNames)
        Console.WriteLine("->{0}", name);
    Console.WriteLine();
}
```

Interesting stuff, huh? Clearly the `System.Reflection` namespace and `System.Type` class allow you to reflect over many other aspects of a type beyond what `MyTypeViewer` is currently displaying. As you would hope, you can obtain a type's events, get the list of any generic parameters for a given member, and glean dozens of other details.

Nevertheless, at this point you have created a (somewhat capable) object browser. The major limitation, of course, is that you have no way to reflect beyond the current assembly (`MyTypeViewer`) or the always-accessible `mscorlib.dll`. This begs the question, "How can I build applications that can load (and reflect over) assemblies not referenced at compile time?" Glad you asked.

■ **Source Code** You can find the `MyTypeViewer` project in the Chapter 15 subdirectory.

Dynamically Loading Assemblies

In Chapter 14, you learned all about how the CLR consults the assembly manifest when probing for an externally referenced assembly. However, there will be many times when you need to load assemblies on the fly programmatically, even if there is no record of said assembly in the manifest. Formally speaking, the act of loading external assemblies on demand is known as a *dynamic load*.

`System.Reflection` defines a class named `Assembly`. Using this class, you are able to dynamically load an assembly, as well as discover properties about the assembly itself. Using the `Assembly` type, you are able to dynamically load private or shared assemblies, as well as load an assembly located at an arbitrary location. In essence, the `Assembly` class provides methods (`Load()` and `LoadFrom()`, in particular) that allow you to programmatically supply the same sort of information found in a client-side*.`config` file.

To illustrate dynamic loading, create a new Console Application project named `ExternalAssemblyReflector`. Your task is to construct a `Main()` method that prompts for the friendly name of an assembly to load dynamically. You will pass the `Assembly` reference into a helper method named `DisplayTypes()`, which will simply print the names of each class, interface, structure, enumeration, and delegate it contains. The code is refreshingly simple.

```
using System;
using System.Collections.Generic;
using System.Linq;
using System.Text;

using System.Reflection;
using System.IO; // For FileNotFoundException definition.

namespace ExternalAssemblyReflector
{
    class Program
    {
        static void DisplayTypesInAsm(Assembly asm)
        {
            Console.WriteLine("\n***** Types in Assembly *****");
            Console.WriteLine("->{0}", asm.FullName);
            Type[] types = asm.GetTypes();
            foreach (Type t in types)
                Console.WriteLine("Type: {0}", t);
            Console.WriteLine("");
        }

        static void Main(string[] args)
        {
            Console.WriteLine("***** External Assembly Viewer *****");

            string asmName = "";
            Assembly asm = null;

            do
            {
                Console.WriteLine("\nEnter an assembly to evaluate");
                Console.Write("or enter Q to quit: ");

                // Get name of assembly.
                asmName = Console.ReadLine();

                // Does user want to quit?
                if (asmName.ToUpper() == "Q")
                {
                    break;
                }
            }
        }
    }
}
```

```

// Try to load assembly.
try
{
    asm = Assembly.Load(asmName);
    DisplayTypesInAsm(asm);
}
catch
{
    Console.WriteLine("Sorry, can't find assembly.");
}
} while (true);
}
}
}

```

Notice that the static `Assembly.Load()` method has been passed only the friendly name of the assembly you are interested in loading into memory. Thus, if you want to reflect over `CarLibrary.dll`, you will need to copy the `CarLibrary.dll` binary to the `\bin\Debug` directory of the `ExternalAssemblyReflector` application to run this program. Once you do, you will find output similar to the following:

```

**** External Assembly Viewer ****

Enter an assembly to evaluate
or enter Q to quit: CarLibrary

**** Types in Assembly ****
->CarLibrary, Version=2.0.0.0, Culture=neutral, PublicKeyToken=33a2bc294331e8b9
Type: CarLibrary.MusicMedia
Type: CarLibrary.EngineState
Type: CarLibrary.Car
Type: CarLibrary.SportsCar
Type: CarLibrary.Minivan

```

If you want to make `ExternalAssemblyReflector` more flexible, you can update your code to load the external assembly using `Assembly.LoadFrom()` rather than `Assembly.Load()`, like so:

```

try
{
    asm = Assembly.LoadFrom(asmName);
    DisplayTypesInAsm(asm);
}
}

```

By doing so, you can enter an absolute path to the assembly you want to view (e.g., `C:\MyApp\MyAsm.dll`). Essentially, `Assembly.LoadFrom()` allows you to programmatically supply a `<codeBase>` value. With this adjustment, you can now pass in a full path to your Console Application project. Thus, if `CarLibrary.dll` was located under `C:\MyCode`, you could enter the following:

```
***** External Assembly Viewer *****
```

```
Enter an assembly to evaluate
or enter Q to quit: C:\MyCode\CarLibrary.dll
```

```
***** Types in Assembly *****
```

```
->CarLibrary, Version=2.0.0.0, Culture=neutral, PublicKeyToken=33a2bc294331e8b9
Type: CarLibrary.EngineState
Type: CarLibrary.Car
Type: CarLibrary.SportsCar
Type: CarLibrary.Minivan
```

■ **Source Code** The `ExternalAssemblyReflector` project is in the [Chapter 15](#) subdirectory.

Reflecting on Shared Assemblies

The `Assembly.Load()` method has been overloaded a number of times. One variation allows you to specify a culture value (for localized assemblies), as well as a version number and public key token value (for shared assemblies). Collectively speaking, the set of items identifying an assembly is termed the *display name*.

The format of a display name is a comma-delimited string of name-value pairs that begins with the friendly name of the assembly, followed by optional qualifiers (that may appear in any order). Here is the template to follow (optional items appear in parentheses):

```
Name (,Version = major.minor.build.revision) (,Culture = culture token)
(,PublicKeyToken= public key token)
```

When you're crafting a display name, the convention `PublicKeyToken=null` indicates that binding and matching against a nonstrongly named assembly is required. Additionally, `Culture=""` indicates matching against the default culture of the target machine, for example:

```
// Load version 1.0.0.0 of CarLibrary using the default culture.
Assembly a =
    Assembly.Load(@"CarLibrary, Version=1.0.0.0, PublicKeyToken=null, Culture="");
```

Also be aware that the `System.Reflection` namespace supplies the `AssemblyName` type, which allows you to represent the preceding string information in a handy object variable. Typically, this class is used in conjunction with `System.Version`, which is an OO wrapper around an assembly's version number. Once you have established the display name, it can then be passed into the overloaded `Assembly.Load()` method, like so:

```
// Make use of AssemblyName to define the display name.
AssemblyName asmName;
asmName = new AssemblyName();
asmName.Name = "CarLibrary";
```

```
Version v = new Version("1.0.0.0");
asmName.Version = v;
Assembly a = Assembly.Load(asmName);
```

To load a shared assembly from the GAC, the `Assembly.Load()` parameter must specify a `PublicKeyToken` value. For example, assume you have a new Console Application project named `SharedAsmReflector` and want to load version 4.0.0.0 of the `System.Windows.Forms.dll` assembly provided by the .NET base class libraries. Given that the number of types in this assembly is quite large, the following application prints out only the names of public enums, using a simple LINQ query:

```
using System;
using System.Collections.Generic;
using System.Linq;
using System.Text;

using System.Reflection;
using System.IO;

namespace SharedAsmReflector
{
    public class SharedAsmReflector
    {
        private static void DisplayInfo(Assembly a)
        {
            Console.WriteLine("***** Info about Assembly *****");
            Console.WriteLine("Loaded from GAC? {0}", a.GlobalAssemblyCache);
            Console.WriteLine("Asm Name: {0}", a.GetName().Name);
            Console.WriteLine("Asm Version: {0}", a.GetName().Version);
            Console.WriteLine("Asm Culture: {0}",
                a.GetName().CultureInfo.DisplayName);
            Console.WriteLine("\nHere are the public enums:");

            // Use a LINQ query to find the public enums.
            Type[] types = a.GetTypes();
            var publicEnums = from pe in types where pe.IsEnum &&
                pe.IsPublic select pe;

            foreach (var pe in publicEnums)
            {
                Console.WriteLine(pe);
            }
        }

        static void Main(string[] args)
        {
            Console.WriteLine("***** The Shared Asm Reflector App *****\n");

            // Load System.Windows.Forms.dll from GAC.
            string displayName = null;
            displayName = "System.Windows.Forms," +
                "Version=4.0.0.0," +
```

```

        "PublicKeyToken=b77a5c561934e089," +
        @"Culture=""");
    Assembly asm = Assembly.Load(displayName);
    DisplayInfo(asm);
    Console.WriteLine("Done!");
    Console.ReadLine();
    }
}
}

```

■ **Source Code** The SharedAsmReflector project is in the Chapter 15 subdirectory.

At this point, you should understand how to use some of the core members of the `System.Reflection` namespace to discover metadata at runtime. Of course, I realize despite the “cool factor,” you likely will not need to build custom object browsers at your place of employment too often. Do recall, however, that reflection services are the foundation for a number of common programming activities, including late binding.

Understanding Late Binding

Simply put, *late binding* is a technique in which you are able to create an instance of a given type and invoke its members at runtime without having hard-coded compile-time knowledge of its existence. When you are building an application that binds late to a type in an external assembly, you have no reason to set a reference to the assembly; therefore, the caller’s manifest has no direct listing of the assembly.

At first glance, it is not easy to see the value of late binding. It is true that if you can “bind early” to an object (e.g., add an assembly reference and allocate the type using the C# `new` keyword), you should opt to do so. For one reason, early binding allows you to determine errors at compile time, rather than at runtime. Nevertheless, late binding does have a critical role in any extendable application you may be building. You will have a chance to build such an “extendable” program at the end of this chapter, in the section “Building an Extendable Application.” Until then, let’s examine the role of the `Activator` class.

The `System.Activator` Class

The `System.Activator` class (defined in `mscorlib.dll`) is the key to the .NET late-binding process. For the current example, you are interested only in the `Activator.CreateInstance()` method, which is used to create an instance of a type à la late binding. This method has been overloaded numerous times to provide a good deal of flexibility. The simplest variation of the `CreateInstance()` member takes a valid `Type` object that describes the entity you want to allocate into memory on the fly.

Create a new Console Application project named `LateBindingApp` and import the `System.IO` and `System.Reflection` namespaces via the C# `using` keyword. Now, update the `Program` class as follows:

```

// This program will load an external library,
// and create an object using late binding.
public class Program
{
    static void Main(string[] args)
    {
        Console.WriteLine("***** Fun with Late Binding *****");
    }
}

```

```

// Try to load a local copy of CarLibrary.
Assembly a = null;
try
{
    a = Assembly.Load("CarLibrary");
}
catch(FileNotFoundException ex)
{
    Console.WriteLine(ex.Message);
    return;
}
if(a != null)
    CreateUsingLateBinding(a);

Console.ReadLine();
}

static void CreateUsingLateBinding(Assembly asm)
{
    try
    {
        // Get metadata for the Minivan type.
        Type miniVan = asm.GetType("CarLibrary.Minivan");

        // Create a Minivan instance on the fly.
        object obj = Activator.CreateInstance(miniVan);
        Console.WriteLine("Created a {0} using late binding!", obj);
    }
    catch(Exception ex)
    {
        Console.WriteLine(ex.Message);
    }
}
}

```

Now, before you run this application, you will need to manually place a copy of `CarLibrary.dll` into the `bin\Debug` folder of this new application using Windows Explorer. The reason is that you are calling `Assembly.Load()` and, therefore, the CLR will probe only in the client folder (if you want, you could enter a path to the assembly using `Assembly.LoadFrom()`; however, there is no need to do so).

■ **Note** Don't add a reference to `CarLibrary.dll` using Visual Studio for this example! That will record this library in the client's manifest. The whole point of late binding is that you are trying to create an object that is not known at compile time.

Notice that the `Activator.CreateInstance()` method returns a `System.Object` rather than a strongly typed `MiniVan`. Therefore, if you apply the dot operator on the `obj` variable, you will fail to see any members of the `MiniVan` class. At first glance, you might assume you can remedy this problem with an explicit cast, like so:

```
// Cast to get access to the members of MiniVan?
// Nope! Compiler error!
object obj = (MiniVan)Activator.CreateInstance(minivan);
```

However, because your program has not added a reference to `CarLibrary.dll`, you cannot use the `C#` `using` keyword to import the `CarLibrary` namespace and, therefore, you can't use a `MiniVan` during the casting operation! Remember that the whole point of late binding is to create instances of objects for which there is no compile-time knowledge. Given this, how can you invoke the underlying methods of the `MiniVan` object stored in the `System.Object` reference? The answer, of course, is by using reflection.

Invoking Methods with No Parameters

Assume you want to invoke the `TurboBoost()` method of the `MiniVan`. As you recall, this method will set the state of the engine to “dead” and display an informational message box. The first step is to obtain a `MethodInfo` object for the `TurboBoost()` method using `Type.GetMethod()`. From the resulting `MethodInfo`, you are then able to call `MiniVan.TurboBoost` using `Invoke()`. `MethodInfo.Invoke()` requires you to send in all parameters that are to be given to the method represented by `MethodInfo`. These parameters are represented by an array of `System.Object` types (as the parameters for a given method could be any number of various entities).

Given that `TurboBoost()` does not require any parameters, you can simply pass `null` (meaning “this method has no parameters”). Update your `CreateUsingLateBinding()` method as follows:

```
static void CreateUsingLateBinding(Assembly asm)
{
    try
    {
        // Get metadata for the Minivan type.
        Type miniVan = asm.GetType("CarLibrary.Minivan");

        // Create the Minivan on the fly.
        object obj = Activator.CreateInstance(miniVan);
        Console.WriteLine("Created a {0} using late binding!", obj);

        // Get info for TurboBoost.
        MethodInfo mi = miniVan.GetMethod("TurboBoost");

        // Invoke method ('null' for no parameters).
        mi.Invoke(obj, null);
    }
    catch(Exception ex)
    {
        Console.WriteLine(ex.Message);
    }
}
```

At this point, you will see the message box shown in [Figure 15-2](#), once the `TurboBoost()` method is invoked.

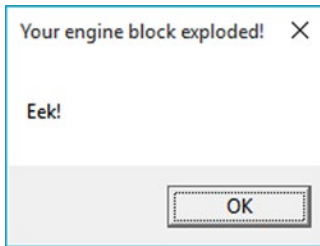

Figure 15-2. Late-bound method invocation

Invoking Methods with Parameters

When you want to use late binding to invoke a method requiring parameters, you should package up the arguments as a loosely typed array of objects. Recall that version 2.0.0.0 of `CarLibrary.dll` defined the following method in the `Car` class:

```
public void TurnOnRadio(bool musicOn, MusicMedia mm)
{
    if (musicOn)
        MessageBox.Show(string.Format("Jamming {0}", mm));
    else
        MessageBox.Show("Quiet time...");
}
```

This method takes two parameters: a Boolean representing if the automobile’s music system should be turned on or off and an enum that represents the type of music player. Recall this enum was structured as so:

```
public enum MusicMedia
{
    musicCd, // 0
    musicTape, // 1
    musicRadio, // 2
    musicMp3 // 3
}
```

Here is a new method of the `Program` class, which invokes `TurnOnRadio()`. Notice that you are using the underlying numerical values of the `MusicMedia` enumeration to specify a “radio” media player.

```
static void InvokeMethodWithArgsUsingLateBinding(Assembly asm)
{
    try
    {
        // First, get a metadata description of the sports car.
        Type sport = asm.GetType("CarLibrary.SportsCar");

        // Now, create the sports car.
        object obj = Activator.CreateInstance(sport);

        // Invoke TurnOnRadio() with arguments.
        MethodInfo mi = sport.GetMethod("TurnOnRadio");
        mi.Invoke(obj, new object[] { true, 2 });
    }
}
```

```

catch (Exception ex)
{
    Console.WriteLine(ex.Message);
}
}

```

Ideally, at this point, you can see the relationships among reflection, dynamic loading, and late binding. To be sure, the reflection API provides many additional features beyond what has been covered here, but you should be in good shape to dig into more details if you are interested.

Again, you still might wonder exactly *when* you should use these techniques in your own applications. The conclusion of this chapter should shed light on this issue; however, the next topic under investigation is the role of .NET attributes.

■ **Source Code** The `LateBindingApp` project is in the Chapter 15 subdirectory.

Understanding the Role of .NET Attributes

As illustrated at beginning of this chapter, one role of a .NET compiler is to generate metadata descriptions for all defined and referenced types. In addition to this standard metadata contained within any assembly, the .NET platform provides a way for programmers to embed additional metadata into an assembly using *attributes*. In a nutshell, attributes are nothing more than code annotations that can be applied to a given type (class, interface, structure, etc.), member (property, method, etc.), assembly, or module.

.NET attributes are class types that extend the abstract `System.Attribute` base class. As you explore the .NET namespaces, you will find many predefined attributes that you are able to use in your applications. Furthermore, you are free to build custom attributes to further qualify the behavior of your types by creating a new type deriving from `Attribute`.

The .NET base class library provides a number of attributes in various namespaces. Table 15-3 gives a snapshot of some—but by *absolutely* no means all—predefined attributes.

Table 15-3. *A Tiny Sampling of Predefined Attributes*

| Attribute | Meaning in Life |
|-------------------|--|
| [CLSCompliant] | Enforces the annotated item to conform to the rules of the Common Language Specification (CLS). Recall that CLS-compliant types are guaranteed to be used seamlessly across all .NET programming languages. |
| [DllImport] | Allows .NET code to make calls to any unmanaged C- or C++-based code library, including the API of the underlying operating system. Do note that [DllImport] is not used when communicating with COM-based software. |
| [Obsolete] | Marks a deprecated type or member. If other programmers attempt to use such an item, they will receive a compiler warning describing the error of their ways. |
| [Serializable] | Marks a class or structure as being “serializable,” meaning it is able to persist its current state into a stream. |
| [NonSerialized] | Specifies that a given field in a class or structure should not be persisted during the serialization process. |
| [ServiceContract] | Marks a method as a contract implemented by a WCF service. |

Understand that when you apply attributes in your code, the embedded metadata is essentially useless until another piece of software explicitly reflects over the information. If this is not the case, the blurb of metadata embedded within the assembly is ignored and completely harmless.

Attribute Consumers

As you would guess, the .NET 4.6 Framework SDK ships with numerous utilities that are indeed on the lookout for various attributes. The C# compiler (`csc.exe`) itself has been preprogrammed to discover the presence of various attributes during the compilation cycle. For example, if the C# compiler encounters the `[CLSCompliant]` attribute, it will automatically check the attributed item to ensure it is exposing only CLS-compliant constructs. By way of another example, if the C# compiler discovers an item attributed with the `[Obsolete]` attribute, it will display a compiler warning in the Visual Studio Error List window.

In addition to development tools, numerous methods in the .NET base class libraries are preprogrammed to reflect over specific attributes. For example, if you want to persist the state of an object to file, all you are required to do is annotate your class or structure with the `[Serializable]` attribute. If the `Serialize()` method of the `BinaryFormatter` class encounters this attribute, the object is automatically persisted to file in a compact binary format.

Finally, you are free to build applications that are programmed to reflect over your own custom attributes, as well as any attribute in the .NET base class libraries. By doing so, you are essentially able to create a set of “keywords” that are understood by a specific set of assemblies.

Applying Attributes in C#

To illustrate the process of applying attributes in C#, create a new Console Application project named `ApplyingAttributes`. Assume you want to build a class named `Motorcycle` that can be persisted in a binary format. To do so, simply apply the `[Serializable]` attribute to the class definition. If you have a field that should not be persisted, you may apply the `[NonSerialized]` attribute.

```
// This class can be saved to disk.
[Serializable]
public class Motorcycle
{
    // However, this field will not be persisted.
    [NonSerialized]
    float weightOfCurrentPassengers;
    // These fields are still serializable.
    bool hasRadioSystem;
    bool hasHeadSet;
    bool hasSissyBar;
}
```

■ **Note** An attribute applies to the “very next” item. For example, the only nonserialized field of the `Motorcycle` class is `weightOfCurrentPassengers`. The remaining fields are serializable given that the entire class has been annotated with `[Serializable]`.

At this point, don’t concern yourself with the actual process of object serialization (Chapter 20 examines the details). Just notice that when you want to apply an attribute, the name of the attribute is sandwiched between square brackets.

Once this class has been compiled, you can view the extra metadata using `ildasm.exe`. Notice that these attributes are recorded using the `serializable` token (see the red triangle immediately inside the `Motorcycle` class) and the `notserialized` token (on the `weightOfCurrentPassengers` field; see Figure 15-3).

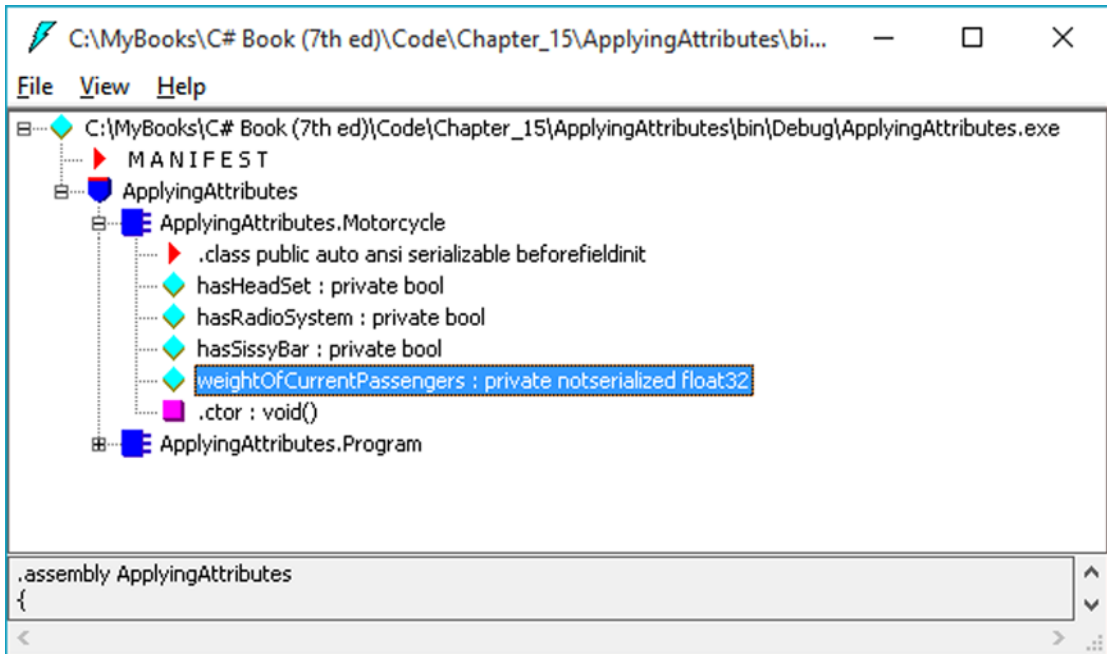

Figure 15-3. Attributes shown in `ildasm.exe`

As you might guess, a single item can be attributed with multiple attributes. Assume you have a legacy C# class type (`HorseAndBuggy`) that was marked as `serializable` but is now considered obsolete for current development. Rather than deleting the class definition from your code base (and risk breaking existing software), you can mark the class with the `[Obsolete]` attribute. To apply multiple attributes to a single item, simply use a comma-delimited list, like so:

```
[Serializable, Obsolete("Use another vehicle!")]
public class HorseAndBuggy
{
    // ...
}
```

As an alternative, you can also apply multiple attributes on a single item by stacking each attribute as follows (the end result is identical):

```
[Serializable]
[Obsolete("Use another vehicle!")]
public class HorseAndBuggy
{
    // ...
}
```

C# Attribute Shorthand Notation

If you were consulting the .NET Framework 4.6 SDK documentation, you might have noticed that the actual class name of the [Obsolete] attribute is `ObsoleteAttribute`, not `Obsolete`. As a naming convention, all .NET attributes (including custom attributes you may create yourself) are suffixed with the `Attribute` token. However, to simplify the process of applying attributes, the C# language does not require you to type in the `Attribute` suffix. Given this, the following iteration of the `HorseAndBuggy` type is identical to the previous (it just involves a few more keystrokes):

```
[SerializableAttribute]
[ObsoleteAttribute("Use another vehicle!")]
public class HorseAndBuggy
{
    // ...
}
```

Be aware that this is a courtesy provided by C#. Not all .NET-enabled languages support this shorthand attribute syntax.

Specifying Constructor Parameters for Attributes

Notice that the [Obsolete] attribute is able to accept what appears to be a constructor parameter. If you view the formal definition of the [Obsolete] attribute by right-clicking the item in the code editor and selecting the Go To Definition menu option, you will find that this class indeed provides a constructor receiving a `System.String`.

```
public sealed class ObsoleteAttribute : Attribute
{
    public ObsoleteAttribute(string message, bool error);
    public ObsoleteAttribute(string message);
    public ObsoleteAttribute();
    public bool IsError { get; }
    public string Message { get; }
}
```

Understand that when you supply constructor parameters to an attribute, the attribute is *not* allocated into memory until the parameters are reflected upon by another type or an external tool. The string data defined at the attribute level is simply stored within the assembly as a blurb of metadata.

The Obsolete Attribute in Action

Now that `HorseAndBuggy` has been marked as obsolete, if you were to allocate an instance of this type:

```
static void Main(string[] args)
{
    HorseAndBuggy mule = new HorseAndBuggy();
}
```

you would find that the supplied string data is extracted and displayed within the Error List window of Visual Studio, as well as on the offending line of code when you hover your mouse cursor above the obsolete type (see Figure 15-4).

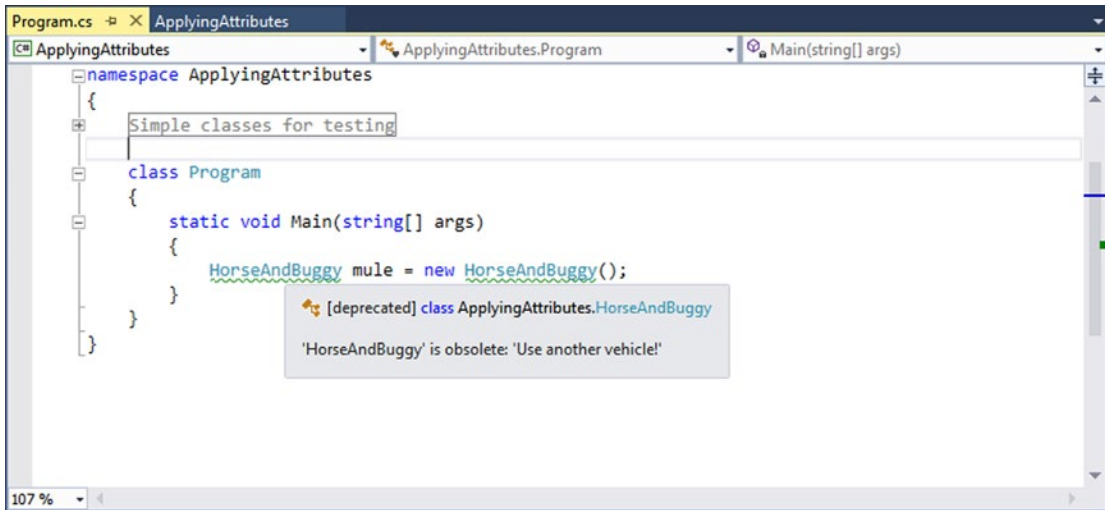

Figure 15-4. Attributes in action

In this case, the “other piece of software” that is reflecting on the [Obsolete] attribute is the C# compiler. Ideally, at this point, you should understand the following key points regarding .NET attributes:

- Attributes are classes that derive from `System.Attribute`.
- Attributes result in embedded metadata.
- Attributes are basically useless until another agent reflects upon them.
- Attributes are applied in C# using square brackets.

Next up, let’s examine how you can build your own custom attributes and a piece of custom software that reflects over the embedded metadata.

■ **Source Code** The `ApplyingAttributes` project is in the Chapter 15 subdirectory.

Building Custom Attributes

The first step in building a custom attribute is to create a new class deriving from `System.Attribute`. Keeping in step with the automobile theme used throughout this book, assume you have created a new C# Class Library project named `AttributedCarLibrary`. This assembly will define a handful of vehicles, each of which is described using a custom attribute named `VehicleDescriptionAttribute`, as follows:

```
// A custom attribute.
public sealed class VehicleDescriptionAttribute : System.Attribute
{
    public string Description { get; set; }
}
```

```

public VehicleDescriptionAttribute(string vehicalDescription)
{
    Description = vehicalDescription;
}
public VehicleDescriptionAttribute(){ }
}

```

As you can see, `VehicleDescriptionAttribute` maintains a piece of string data manipulated using an automatic property (`Description`). Beyond the fact that this class derived from `System.Attribute`, there is nothing unique to this class definition.

■ **Note** For security reasons, it is considered a .NET best practice to design all custom attributes as sealed. In fact, Visual Studio provides a code snippet named `Attribute` that will dump out a new `System.Attribute`-derived class into your code window. See Chapter 2 for full explication of using code snippets; however, recall you can expand any snippet by typing its name and pressing the Tab key twice.

Applying Custom Attributes

Given that `VehicleDescriptionAttribute` is derived from `System.Attribute`, you are now able to annotate your vehicles as you see fit. For testing purposes, add the following class definitions to your new class library:

```

// Assign description using a "named property."
[Serializable]
[VehicleDescription(Description = "My rocking Harley")]
public class Motorcycle
{
}

[Serializable]
[Obsolete ("Use another vehicle!")]
[VehicleDescription("The old gray mare, she ain't what she used to be...")]
public class HorseAndBuggy
{
}

[VehicleDescription("A very long, slow, but feature-rich auto")]
public class Winnebago
{
}

```

Named Property Syntax

Notice that the description of the `Motorcycle` is assigned a description using a new bit of attribute-centric syntax termed a *named property*. In the constructor of the first `[VehicleDescription]` attribute, you set the underlying string data by using the `Description` property. If this attribute is reflected upon by an external agent, the value is fed into the `Description` property (named property syntax is legal only if the attribute supplies a writable .NET property).

In contrast, the `HorseAndBuggy` and `Winnebago` types are not using named property syntax and are simply passing the string data via the custom constructor. In any case, once you compile the `AttributedCarLibrary` assembly, you can use `ildasm.exe` to view the injected metadata descriptions for your type. For example, Figure 15-5 shows an embedded description of the `Winnebago` class, specifically the data within the `beforefieldinit` item in `ildasm.exe`.

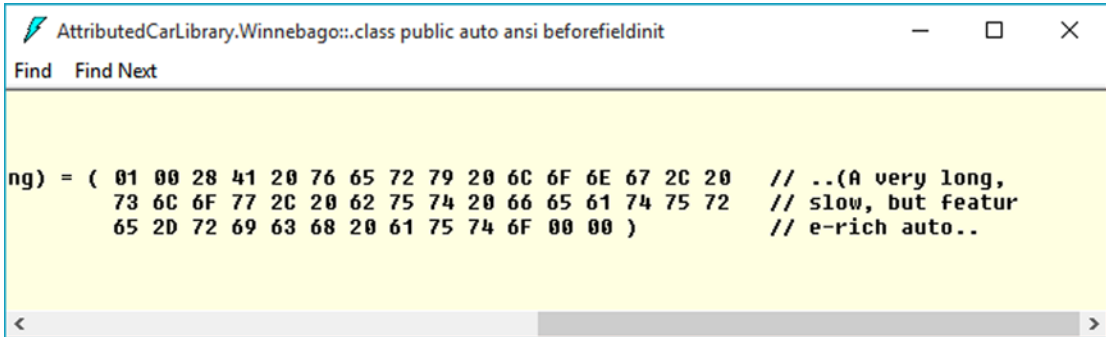

Figure 15-5. Embedded vehicle description data

Restricting Attribute Usage

By default, custom attributes can be applied to just about any aspect of your code (methods, classes, properties, and so on). Thus, if it made sense to do so, you could use `VehicleDescription` to qualify methods, properties, or fields (among other things).

```
[VehicleDescription("A very long, slow, but feature-rich auto")]
public class Winnebago
{
    [VehicleDescription("My rocking CD player")]
    public void PlayMusic(bool On)
    {
        ...
    }
}
```

In some cases, this is exactly the behavior you require. Other times, however, you may want to build a custom attribute that can be applied only to select code elements. If you want to constrain the scope of a custom attribute, you will need to apply the `[AttributeUsage]` attribute on the definition of your custom attribute. The `[AttributeUsage]` attribute allows you to supply any combination of values (via an OR operation) from the `AttributeTargets` enumeration, like so:

```
// This enumeration defines the possible targets of an attribute.
public enum AttributeTargets
{
    All, Assembly, Class, Constructor,
    Delegate, Enum, Event, Field, GenericParameter,
    Interface, Method, Module, Parameter,
    Property, ReturnValue, Struct
}
```

Furthermore, `[AttributeUsage]` also allows you to optionally set a named property (`AllowMultiple`) that specifies whether the attribute can be applied more than once on the same item (the default is `false`). As well, `[AttributeUsage]` allows you to establish whether the attribute should be inherited by derived classes using the `Inherited` named property (the default is `true`).

To establish that the `[VehicleDescription]` attribute can be applied only once on a class or structure, you can update the `VehicleDescriptionAttribute` definition as follows:

```
// This time, we are using the AttributeUsage attribute
// to annotate our custom attribute.
[AttributeUsage(AttributeTargets.Class | AttributeTargets.Struct,
                Inherited = false)]
public sealed class VehicleDescriptionAttribute : System.Attribute
{
    ...
}
```

With this, if a developer attempted to apply the `[VehicleDescription]` attribute on anything other than a class or structure, he or she is issued a compile-time error.

Assembly-Level Attributes

It is also possible to apply attributes on all types within a given assembly using the `[assembly:]` tag. For example, assume you want to ensure that every public member of every public type defined within your assembly is CLS compliant.

■ **Note** Chapter 1 mentioned the role of CLS-compliant assemblies. Recall that a CLS-compliant assembly can be used by all .NET programming languages out of the box. If you create public members of public types, which expose non-CLS-compliant programming constructs (such as unsigned data or pointer parameters), other .NET languages may not be able to use your functionality. Therefore, if you are building C# code libraries that need to be used by a wide variety of .NET languages, checking for CLS compliance is a must.

To do so, simply add the following assembly-level attribute at the top of any C# source code file. Be aware that all assembly- or module-level attributes must be listed outside the scope of any namespace scope! If you add assembly- or module-level attributes to your project, here is a recommended file layout to follow:

```
// List "using" statements first.
using System;
using System.Collections.Generic;
using System.Linq;
using System.Text;

// Now list any assembly- or module-level attributes.
// Enforce CLS compliance for all public types in this assembly.
[assembly: CLSCompliant(true)]
```

```
// Now, your namespace(s) and types.
namespace AttributedCarLibrary
{
    // Types...
}
```

If you now add a bit of code that falls outside the CLS specification (such as an exposed point of unsigned data):

```
// Ulong types don't jibe with the CLS.
public class Winnebago
{
    public ulong notCompliant;
}
```

you are issued a compiler warning.

The Visual Studio AssemblyInfo.cs File

By default, Visual Studio projects receive a file named `AssemblyInfo.cs`, which can be viewed by expanding the Properties icon of the Solution Explorer (see Figure 15-6).

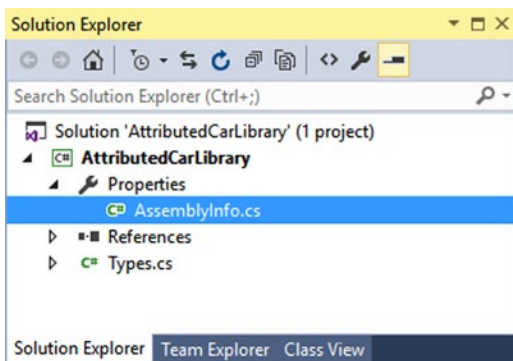

Figure 15-6. The *AssemblyInfo.cs* file

This file is a handy place to put attributes that are to be applied at the assembly level. You might recall from Chapter 14, during the examination of .NET assemblies, that the manifest contains assembly-level metadata, much of which comes from the assembly-level attributes shown in Table 15-4.

Table 15-4. *Select Assembly-Level Attributes*

| Attribute | Meaning in Life |
|-----------------------|--|
| [AssemblyCompany] | Holds basic company information |
| [AssemblyCopyright] | Holds any copyright information for the product or assembly |
| [AssemblyCulture] | Provides information on what cultures or languages the assembly supports |
| [AssemblyDescription] | Holds a friendly description of the product or modules that make up the assembly |
| [AssemblyKeyFile] | Specifies the name of the file containing the key pair used to sign the assembly (i.e., establish a strong name) |
| [AssemblyProduct] | Provides product information |
| [AssemblyTrademark] | Provides trademark information |
| [AssemblyVersion] | Specifies the assembly's version information, in the format <major.minor.build.revision> |

■ **Source Code** The `AttributedCarLibrary` project is included in the Chapter 15 subdirectory.

Reflecting on Attributes Using Early Binding

Remember that an attribute is quite useless until another piece of software reflects over its values. Once a given attribute has been discovered, that piece of software can take whatever course of action necessary. Now, like any application, this “other piece of software” could discover the presence of a custom attribute using either early binding or late binding. If you want to make use of early binding, you’ll require the client application to have a compile-time definition of the attribute in question (`VehicleDescriptionAttribute`, in this case). Given that the `AttributedCarLibrary` assembly has defined this custom attribute as a public class, early binding is the best option.

To illustrate the process of reflecting on custom attributes, create a new C# Console Application project named `VehicleDescriptionAttributeReader`. Next, add a reference to the `AttributedCarLibrary` assembly. Finally, update your initial `*.cs` file with the following code:

```
// Reflecting on attributes using early binding.
using System;
using System.Collections.Generic;
using System.Linq;
using System.Text;

using AttributedCarLibrary;

namespace VehicleDescriptionAttributeReader
{
    class Program
    {
```



```

static void Main(string[] args)
{
    Console.WriteLine("***** Value of VehicleDescriptionAttribute *****\n");
    ReflectOnAttributesUsingEarlyBinding();
    Console.ReadLine();
}

private static void ReflectOnAttributesUsingEarlyBinding()
{
    // Get a Type representing the Winnebago.
    Type t = typeof(Winnebago);

    // Get all attributes on the Winnebago.
    object[] customAtts = t.GetCustomAttributes(false);

    // Print the description.
    foreach (VehicleDescriptionAttribute v in customAtts)
        Console.WriteLine("-> {0}\n", v.Description);
}
}
}

```

The `Type.GetCustomAttributes()` method returns an object array that represents all the attributes applied to the member represented by the `Type` (the `Boolean` parameter controls whether the search should extend up the inheritance chain). Once you have obtained the list of attributes, iterate over each `VehicleDescriptionAttribute` class and print out the value obtained by the `Description` property.

■ **Source Code** The `VehicleDescriptionAttributeReader` project is included in the [Chapter 15](#) subdirectory.

Reflecting on Attributes Using Late Binding

The previous example used early binding to print out the vehicle description data for the `Winnebago` type. This was possible because the `VehicleDescriptionAttribute` class type was defined as a public member in the `AttributedCarLibrary` assembly. It is also possible to make use of dynamic loading and late binding to reflect over attributes.

Create a new project called `VehicleDescriptionAttributeReaderLateBinding` and copy `AttributedCarLibrary.dll` to the project's `\bin\Debug` directory. Now, update your `Program` class as follows:

```

using System;
using System.Collections.Generic;
using System.Linq;
using System.Text;

using System.Reflection;

namespace VehicleDescriptionAttributeReaderLateBinding
{

```

```

class Program
{
    static void Main(string[] args)
    {
        Console.WriteLine("***** Value of VehicleDescriptionAttribute *****\n");
        ReflectAttributesUsingLateBinding();
        Console.ReadLine();
    }

    private static void ReflectAttributesUsingLateBinding()
    {
        try
        {
            // Load the local copy of AttributedCarLibrary.
            Assembly asm = Assembly.Load("AttributedCarLibrary");

            // Get type info of VehicleDescriptionAttribute.
            Type vehicleDesc =
                asm.GetType("AttributedCarLibrary.VehicleDescriptionAttribute");

            // Get type info of the Description property.
            PropertyInfo propDesc = vehicleDesc.GetProperty("Description");

            // Get all types in the assembly.
            Type[] types = asm.GetTypes();

            // Iterate over each type and obtain any VehicleDescriptionAttributes.
            foreach (Type t in types)
            {
                object[] objs = t.GetCustomAttributes(vehicleDesc, false);

                // Iterate over each VehicleDescriptionAttribute and print
                // the description using late binding.
                foreach (object o in objs)
                {
                    Console.WriteLine("-> {0}: {1}\n",
                        t.Name, propDesc.GetValue(o, null));
                }
            }
        }
        catch (Exception ex)
        {
            Console.WriteLine(ex.Message);
        }
    }
}

```

If you were able to follow along with the examples in this chapter, this code should be (more or less) self-explanatory. The only point of interest is the use of the `PropertyInfo.GetValue()` method, which is used to trigger the property's accessor. Here is the output of the current example:

```
***** Value of VehicleDescriptionAttribute *****
-> Motorcycle: My rocking Harley
-> HorseAndBuggy: The old gray mare, she ain't what she used to be...
-> Winnebago: A very long, slow, but feature-rich auto
```

■ **Source Code** The `VehicleDescriptionAttributeReaderLateBinding` project is included in the Chapter 15 subdirectory.

Putting Reflection, Late Binding, and Custom Attributes in Perspective

Even though you have seen numerous examples of these techniques in action, you may still be wondering when to make use of reflection, dynamic loading, late binding, and custom attributes in your programs. To be sure, these topics can seem a bit on the academic side of programming (which may or may not be a bad thing, depending on your point of view). To help map these topics to a real-world situation, you need a solid example. Assume for the moment that you are on a programming team that is building an application with the following requirement:

- The product must be extendable by the use of additional third-party tools.

What exactly is meant by *extendable*? Well, consider the Visual Studio IDE. When this application was developed, various “hooks” were inserted into the code base to allow other software vendors to “snap” (or plug in) custom modules into the IDE. Obviously, the Visual Studio development team had no way to set references to external .NET assemblies it had not developed yet (thus, no early binding), so how exactly would an application provide the required hooks? Here is one possible way to solve this problem:

1. First, an extendable application must provide some input mechanism to allow the user to specify the module to plug in (such as a dialog box or command-line flag). This requires *dynamic loading*.
2. Second, an extendable application must be able to determine whether the module supports the correct functionality (such as a set of required interfaces) to be plugged into the environment. This requires *reflection*.
3. Finally, an extendable application must obtain a reference to the required infrastructure (such as a set of interface types) and invoke the members to trigger the underlying functionality. This may require *late binding*.

Simply put, if the extendable application has been preprogrammed to query for specific interfaces, it is able to determine at runtime whether the type can be activated. Once this verification test has been passed, the type in question may support additional interfaces that provide a polymorphic fabric to their functionality. This is the exact approach taken by the Visual Studio team and, despite what you might be thinking, is not at all difficult!

Building an Extendable Application

In the sections that follow, I will take you through a complete example that illustrates the process of building an extendable Windows Forms application that can be augmented by the functionality of external assemblies. If you do not have some experience building GUIs with the Windows Forms API, you might want to load up the provided solution code and follow along.

■ **Note** Windows Forms was the initial desktop API of the .NET platform. However, since the release of .NET 3.0, the Windows Presentation Foundation (WPF) API has become an often preferred GUI framework. While this is true, I will use Windows Forms for a number of client GUI examples in this text, as the related code is a bit more intuitive than the corresponding WPF code.

If you are not familiar with the process of building Windows Forms applications, feel free to simply open up the supplied sample code and follow along. To serve as a road map, the extendable application entails the following assemblies:

- `CommonSnappableTypes.dll`: This assembly contains type definitions that will be used by each snap-in object and will be directly referenced by the Windows Forms application.
- `CSharpSnapIn.dll`: A snap-in written in C#, which leverages the types of `CommonSnappableTypes.dll`.
- `VbSnapIn.dll`: A snap-in written in Visual Basic, which leverages the types of `CommonSnappableTypes.dll`.
- `MyExtendableApp.exe`: This Windows Forms application will be the executable application that may be extended by the functionality of each snap-in.

Again, this application will use dynamic loading, reflection, and late binding to dynamically gain the functionality of assemblies it has no prior knowledge of.

Building CommonSnappableTypes.dll

The first order of business is to create an assembly that contains the types that a given snap-in must leverage to be plugged into the expandable Windows Forms application. The `CommonSnappableTypes` Class Library project defines two types:

```
namespace CommonSnappableTypes
{
    public interface IAppFunctionality
    {
        void DoIt();
    }
    [AttributeUsage(AttributeTargets.Class)]
    public sealed class CompanyInfoAttribute : System.Attribute
    {
        public string CompanyName { get; set; }
        public string CompanyUrl { get; set; }
    }
}
```

The `IAppFunctionality` interface provides a polymorphic interface for all snap-ins that can be consumed by the extendable Windows Forms application. Given that this example is purely illustrative, you supply a single method named `DoIt()`. A more realistic interface (or a set of interfaces) might allow the object to generate scripting code, render an image onto the application's toolbox, or integrate into the main menu of the hosting application.

The `CompanyInfoAttribute` type is a custom attribute that can be applied on any class type that wants to be snapped into the container. As you can tell by the definition of this class, `[CompanyInfo]` allows the developer of the snap-in to provide some basic details about the component's point of origin.

Building the C# Snap-In

Next up, you need to create a type that implements the `IAppFunctionality` interface. Again, to focus on the overall design of an extendable application, a trivial type is in order. Assume a new C# Class Library project named `CSharpSnapIn` defines a class type named `CSharpModule`. Given that this class must make use of the types defined in `CommonSnappableTypes`, be sure to add a reference to the `CommonSnappableTypes` assembly (as well as `System.Windows.Forms.dll` to display a noteworthy message). This being said, here is the code:

```
using System;
using System.Collections.Generic;
using System.Linq;
using System.Text;

using CommonSnappableTypes;
using System.Windows.Forms;

namespace CSharpSnapIn
{
    [CompanyInfo(CompanyName = "FooBar",
        CompanyUrl = "www.FooBar.com")]
    public class CSharpModule : IAppFunctionality
    {
        void IAppFunctionality.DoIt()
        {
            MessageBox.Show("You have just used the C# snap-in!");
        }
    }
}
```

Notice that I chose to make use of explicit interface implementation (see [Chapter 9](#)) when supporting the `IAppFunctionality` interface. This is not required; however, the idea is that the only part of the system that needs to directly interact with this interface type is the hosting Windows application. By explicitly implementing this interface, the `DoIt()` method is not directly exposed from the `CSharpModule` type.

Building the Visual Basic Snap-In

Now, to simulate the role of a third-party vendor who prefers Visual Basic over C#, create a new Visual Basic Class Library (VbSnapIn) that references the same external assemblies as the previous CSharpSnapIn project.

■ **Note** By default, a Visual Basic project will not display the References folder within the Solution Explorer. To add references in a VB project, use the Project ► Add Reference menu option of Visual Studio.

The code is (again) intentionally simple.

```
Imports System.Windows.Forms
Imports CommonSnappableTypes

<CompanyInfo(CompanyName:="Chucky's Software", CompanyUrl:="www.ChuckySoft.com")>
Public Class VbSnapIn
    Implements IAppFunctionality

    Public Sub DoIt() Implements CommonSnappableTypes.IAppFunctionality.DoIt
        MessageBox.Show("You have just used the VB snap in!")
    End Sub
End Class
```

Notice that applying attributes in the syntax of Visual Basic requires angle brackets (< >) rather than square brackets ([]). Also notice that the Implements keyword is used to implement interface types on a given class or structure.

Building an Extendable Windows Forms Application

The final step is to create a new C# Windows Forms application (MyExtendableApp) that allows the user to select a snap-in using a standard Windows Open dialog box. If you have not created a Windows Forms application before, you might want to simply open the completed code sample supplied with the book's source code. However, if you do want to build the GUI yourself, begin this final project of the chapter by selecting a Windows Forms Application project from the New Project dialog box of Visual Studio (see Figure 15-7).

■ **Note** Appendix A provides an overview of the Windows Forms API.

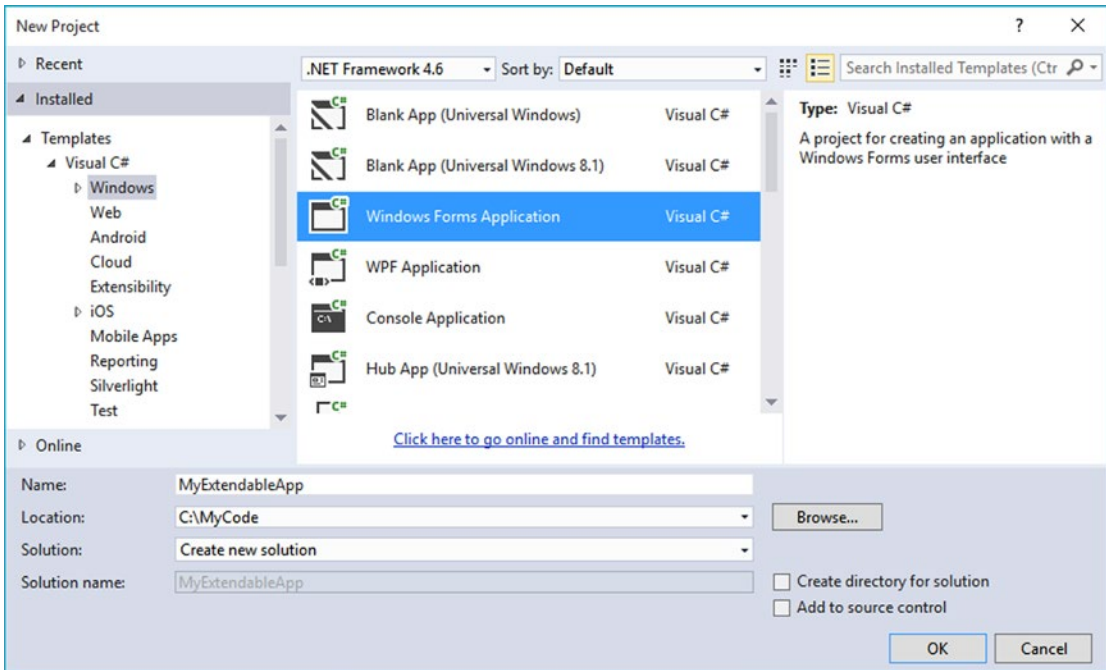

Figure 15-7. Creating a new Windows Forms project with Visual Studio

Now, add a reference to the `CommonSnappableTypes.dll` assembly but *not* the `CSharpSnapIn.dll` or `VbSnapIn.dll` code libraries. As well, import the `System.Reflection` and `CommonSnappableTypes` namespaces into your form’s primary code file (which you can open by right-clicking the form designer and selecting View Code). Remember that the whole goal of this application is to use late binding and reflection to determine the “snapability” of independent binaries created by third-party vendors.

Again, I won’t bother to examine all the details of Windows Forms development at this time. However, the GUI consists of a `MenuStrip` component placed onto the form designer; the component defines a single topmost menu item named `File` that provides a single submenu named `Snap In Module`. As well, the main window will contain a `ListBox` type (which I renamed as `lstLoadedSnapIns`) that will be used to display the names of each snap-in loaded by the user. Figure 15-8 shows the final GUI.

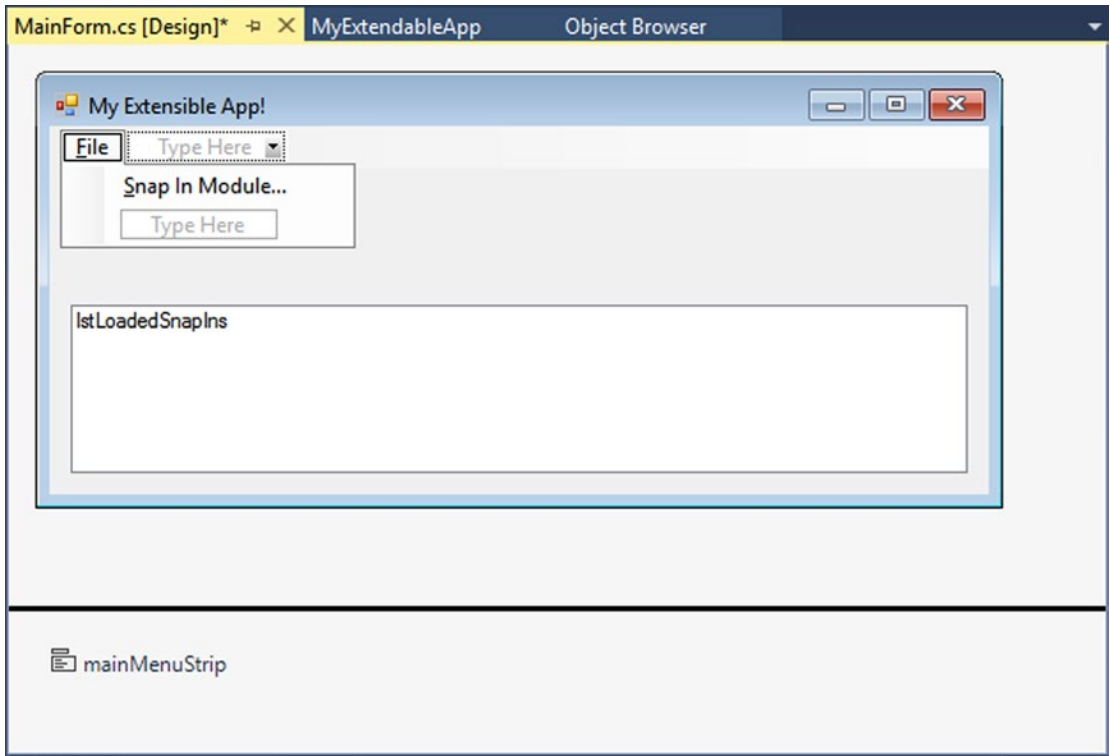

Figure 15-8. GUI for *MyExtensibleApp*

The code that handles the Click event for the File Snap In Module menu item (which may be created simply by double-clicking the menu item from the design-time editor) displays a File Open dialog box and extracts the path to the selected file. Assuming the user did not select the `CommonSnappableTypes.dll` assembly (as this is purely infrastructure), the path is then sent into a helper function named `LoadExternalModule()` for processing (implemented next). This method will return `false` if it is unable to find a class implementing `IAppFunctionality`.

```
private void snapInModuleToolStripMenuItem_Click(object sender,
    EventArgs e)
{
    // Allow user to select an assembly to load.
    OpenFileDialog dlg = new OpenFileDialog();
    if (dlg.ShowDialog() == DialogResult.OK)
    {
        if(dlg.FileName.Contains("CommonSnappableTypes"))
            MessageBox.Show("CommonSnappableTypes has no snap-ins!");
        else if(!LoadExternalModule(dlg.FileName))
            MessageBox.Show("Nothing implements IAppFunctionality!");
    }
}
```

The `LoadExternalModule()` method performs the following tasks:

- Dynamically loads the selected assembly into memory
- Determines whether the assembly contains any types implementing `IAppFunctionality`
- Creates the type using late binding

If a type implementing `IAppFunctionality` is found, the `DoIt()` method is called, and the fully qualified name of the type is added to the `ListBox` (note that the `foreach` loop will iterate over all types in the assembly to account for the possibility that a single assembly has multiple snap-ins).

```
private bool LoadExternalModule(string path)
{
    bool foundSnapIn = false;
    Assembly theSnapInAsm = null;
    try
    {
        // Dynamically load the selected assembly.
        theSnapInAsm = Assembly.LoadFrom(path);
    }
    catch(Exception ex)
    {
        MessageBox.Show(ex.Message);
        return foundSnapIn;
    }
    // Get all IAppFunctionality-compatible classes in assembly.
    var theClassTypes = from t in theSnapInAsm.GetTypes()
                        where t.IsClass &&
                           (t.GetInterface("IAppFunctionality") != null)
                        select t;
    // Now, create the object and call DoIt() method.
    foreach (Type t in theClassTypes)
    {
        foundSnapIn = true;
        // Use late binding to create the type.
        IAppFunctionality itfApp =
            (IAppFunctionality)theSnapInAsm.CreateInstance(t.FullName, true);
        itfApp.DoIt();
        lstLoadedSnapIns.Items.Add(t.FullName);
    }
    return foundSnapIn;
}
```

At this point, you can run your application. When you select the `CSharpSnapIn.dll` or `VbSnapIn.dll` assemblies, you should see the correct message displayed. The final task is to display the metadata provided by the `[CompanyInfo]` attribute. To do so, update `LoadExternalModule()` to call a new helper function named `DisplayCompanyData()` before exiting the `foreach` scope. Notice this method takes a single `System.Type` parameter.

```
private bool LoadExternalModule(string path)
{
    ...
    foreach (Type t in theClassTypes)
    {
        ...
        // Show company info.
        DisplayCompanyData(t);
    }
    return foundSnapIn;
}
```

Using the incoming type, simply reflect over the [CompanyInfo] attribute, like so:

```
private void DisplayCompanyData(Type t)
{
    // Get [CompanyInfo] data.
    var compInfo = from ci in t.GetCustomAttributes(false) where
                    (ci.GetType() == typeof(CompanyInfoAttribute))
                    select ci;

    // Show data.
    foreach (CompanyInfoAttribute c in compInfo)
    {
        MessageBox.Show(c.CompanyUrl,
            string.Format("More info about {0} can be found at", c.CompanyName));
    }
}
```

Figure 15-9 shows one possible run.

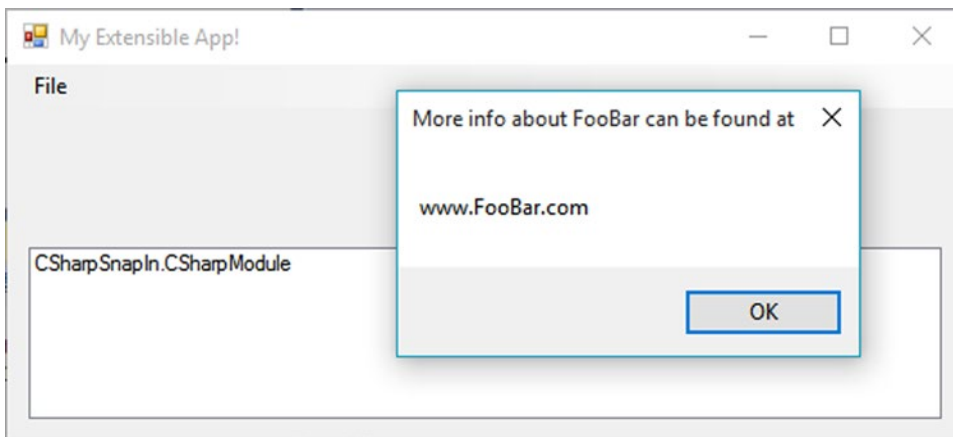

Figure 15-9. Snapping in external assemblies

Excellent! That wraps up the example application. I hope you can see that the topics presented in this chapter can be quite helpful in the real world and are not limited to the tool builders of the world.

■ **Source Code** The `ExtendableApp` folder in the Chapter 15 subdirectory contains the `CommonSnappableTypes`, `CSharpSnapIn`, `VbSnapIn`, and `MyExtendableApp` projects.

Summary

Reflection is an interesting aspect of a robust OO environment. In the world of .NET, the keys to reflection services revolve around the `System.Type` class and the `System.Reflection` namespace. As you have seen, reflection is the process of placing a type under the magnifying glass at runtime to understand the who, what, where, when, why, and how of a given item.

Late binding is the process of creating an instance of a type and invoking its members without prior knowledge of the specific names of said members. Late binding is often a direct result of *dynamic loading*, which allows you to load a .NET assembly into memory programmatically. As shown during this chapter's extendable application example, this is a powerful technique used by tool builders as well as tool consumers.

This chapter also examined the role of attribute-based programming. When you adorn your types with attributes, the result is the augmentation of the underlying assembly metadata.

CHAPTER 16



Dynamic Types and the Dynamic Language Runtime

NET 4.0 introduced a new keyword to the C# language, specifically, `dynamic`. This keyword allows you to incorporate scripting-like behaviors into the strongly typed world of type safety, semicolons, and curly brackets. Using this loose typing, you can greatly simplify some complex coding tasks and also gain the ability to interoperate with a number of dynamic languages (such as IronRuby or IronPython), which are .NET savvy.

In this chapter, you will be introduced to the C# `dynamic` keyword and understand how loosely typed calls are mapped to the correct in-memory object using the Dynamic Language Runtime (DLR). After you understand the services provided by the DLR, you will see examples of using dynamic types to streamline how you can perform late-bound method calls (via reflection services) and to easily communicate with legacy COM libraries.

■ **Note** Don't confuse the C# `dynamic` keyword with the concept of a *dynamic assembly* (see Chapter 18). While you could use the `dynamic` keyword when building a dynamic assembly, these are ultimately two independent concepts.

The Role of the C# `dynamic` Keyword

Back in Chapter 3, you learned about the `var` keyword, which allows you to define local variables in such a way that the underlying data type is determined at compile time, based on the initial assignment (recall that this is termed *implicit typing*). Once this initial assignment has been made, you have a strongly typed variable, and any attempt to assign an incompatible value will result in a compiler error.

To begin your investigation into the C# `dynamic` keyword, create a new Console Application project named `DynamicKeyword`. Now, author the following method in your `Program` class, and verify that the final code statement will indeed trigger a compile time error if uncommented:

```
static void ImplicitlyTypedVariable()
{
    // a is of type List<int>.
    var a = new List<int>();
    a.Add(90);
    // This would be a compile-time error!
    // a = "Hello";
}
```

Using implicit typing simply for the sake of doing so is considered by some to be bad style (if you know you need a `List<int>`, just declare a `List<int>`). However, as you have seen in Chapter 12, implicit typing is useful with LINQ, as many LINQ queries return enumerations of anonymous classes (via projections) that you cannot directly declare in your C# code. However, even in such cases, the implicitly typed variable is, in fact, strongly typed.

On a related note, as you learned in Chapter 6, `System.Object` is the topmost parent class in the .NET Framework and can represent anything at all. Again, if you declare a variable of type `object`, you have a strongly typed piece of data; however, what it points to in memory can differ based on your assignment of the reference. To gain access to the members the object reference is pointing to in memory, you need to perform an explicit cast.

Assume you have a simple class named `Person` that defines two automatic properties (`FirstName` and `LastName`) both encapsulating a `string`. Now, observe the following code:

```
static void UseObjectVariable()
{
    // Assume we have a class named Person.
    object o = new Person() { FirstName = "Mike", LastName = "Larson" };

    // Must cast object as Person to gain access
    // to the Person properties.
    Console.WriteLine("Person's first name is {0}", ((Person)o).FirstName);
}
```

Since the release of .NET 4.0, the C# language introduced a keyword named `dynamic`. From a high level, you can consider the `dynamic` keyword a specialized form of `System.Object`, in that any value can be assigned to a `dynamic` data type. At first glance, this can appear horribly confusing, as it appears you now have three ways to define data whose underlying type is not directly indicated in your code base. For example, this method:

```
static void PrintThreeStrings()
{
    var s1 = "Greetings";
    object s2 = "From";
    dynamic s3 = "Minneapolis";

    Console.WriteLine("s1 is of type: {0}", s1.GetType());
    Console.WriteLine("s2 is of type: {0}", s2.GetType());
    Console.WriteLine("s3 is of type: {0}", s3.GetType());
}
```

would print out the following if invoked from `Main()`:

```
s1 is of type: System.String
s2 is of type: System.String
s3 is of type: System.String
```

What makes a dynamic variable much (much) different from a variable declared implicitly or via a `System.Object` reference is that it is *not strongly typed*. Said another way, dynamic data is not *statically typed*. As far as the C# compiler is concerned, a data point declared with the `dynamic` keyword can be assigned any initial value at all and can be reassigned to any new (and possibly unrelated) value during its lifetime. Consider the following method and the resulting output:

```
static void ChangeDynamicDataType()
{
    // Declare a single dynamic data point
    // named "t".
    dynamic t = "Hello!";
    Console.WriteLine("t is of type: {0}", t.GetType());

    t = false;
    Console.WriteLine("t is of type: {0}", t.GetType());

    t = new List<int>();
    Console.WriteLine("t is of type: {0}", t.GetType());
}
```

```
t is of type: System.String
t is of type: System.Boolean
t is of type: System.Collections.Generic.List`1[System.Int32]
```

At this point in your investigation, do be aware that the previous code would compile and execute identically if you were to declare the `t` variable as a `System.Object`. However, as you will soon see, the `dynamic` keyword offers many additional features.

Calling Members on Dynamically Declared Data

Given that a dynamic variable can take on the identity of any type on the fly (just like a variable of type `System.Object`), the next question on your mind might be about calling members on the dynamic variable (properties, methods, indexers, register with events, etc.). Well, syntactically speaking, it will again look no different. Just apply the dot operator to the dynamic data variable, specify a public member, and supply any arguments (if required).

However (and this is a very big “however”), the validity of the members you specify will not be checked by the compiler! Remember, unlike a variable defined as a `System.Object`, dynamic data is not statically typed. It is not until runtime that you will know whether the dynamic data you invoked supports a specified member, whether you passed in the correct parameters, spelled the member correctly, and so on. Thus, as strange as it might seem, the following method compiles perfectly:

```
static void InvokeMembersOnDynamicData()
{
    dynamic testData1 = "Hello";
    Console.WriteLine(textData1.ToUpper());

    // You would expect compiler errors here!
    // But they compile just fine.
    Console.WriteLine(textData1.toupper());
    Console.WriteLine(textData1.Foo(10, "ee", DateTime.Now));
}
```

Notice the second call to `WriteLine()` attempts to call a method named `toupper()` on the dynamic data point (note the incorrect casing—it should be `ToUpper()`). As you can see, `textData1` is of type `string`, and therefore, you know it does not have a method of this name in all lowercase letters. Furthermore, `string` certainly does not have a method named `Foo()` that takes an `int`, `string`, and `DateTime` object!

Nevertheless, the C# compiler is satisfied. However, if you invoke this method from within `Main()`, you will get runtime errors similar to the following output:

```
Unhandled Exception: Microsoft.CSharp.RuntimeBinder.RuntimeBinderException:
'string' does not contain a definition for 'toupper'
```

Another obvious distinction between calling members on dynamic data and strongly typed data is that when you apply the dot operator to a piece of dynamic data, you will *not* see the expected Visual Studio IntelliSense. The IDE will allow you to enter any member name you could dream up.

It should make sense that IntelliSense is not possible with dynamic data. However, remember that this means you need to be extremely careful when you are typing C# code on such data points. Any misspelling or incorrect capitalization of a member will throw a runtime error, specifically an instance of the `RuntimeBinderException` class.

The Role of the Microsoft.CSharp.dll Assembly

When you create a new Visual Studio C# project, you will automatically have a reference set to an assembly named `Microsoft.CSharp.dll` (you can see this for yourself by looking in the References folder of the Solution Explorer). This library is small and defines only a single namespace (`Microsoft.CSharp.RuntimeBinder`) with two classes (see Figure 16-1).

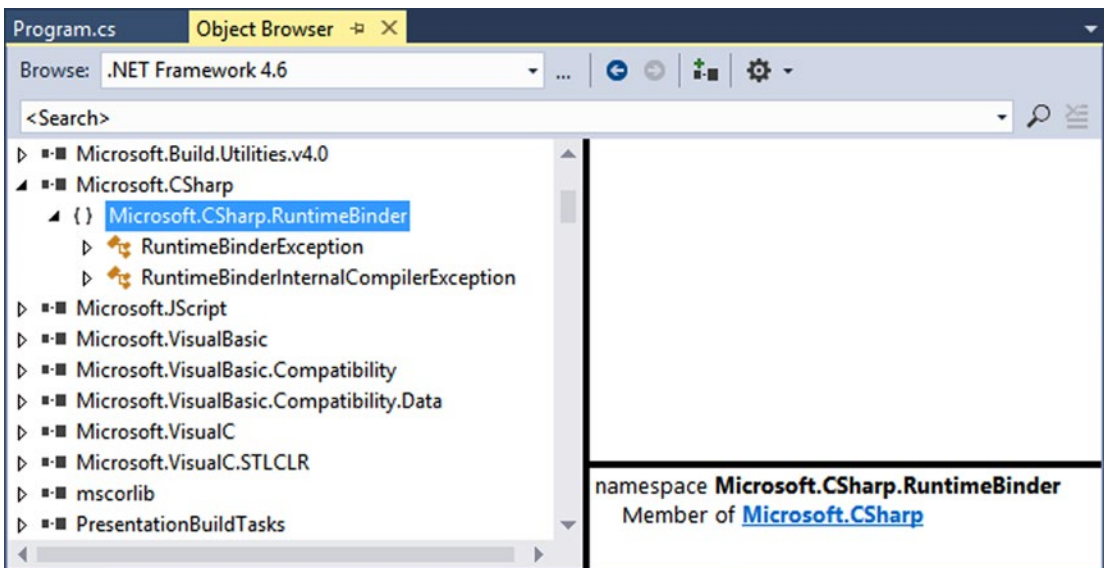

Figure 16-1. The `Microsoft.CSharp.dll` assembly

As you can tell by their names, both of these classes are strongly typed exceptions. The most common class, `RuntimeBinderException`, represents an error that will be thrown if you attempt to invoke a member on a dynamic data type, which does not actually exist (as in the case of the `toupper()` and `Foo()` methods). This same error will be raised if you specify the wrong parameter data to a member that does exist.

Because dynamic data is so volatile, whenever you are invoking members on a variable declared with the `C#dynamic` keyword, you could wrap the calls within a proper `try/catch` block and handle the error in a graceful manner, like so:

```
static void InvokeMembersOnDynamicData()
{
    dynamic textData1 = "Hello";

    try
    {
        Console.WriteLine(textData1.ToUpper());
        Console.WriteLine(textData1.toupper());
        Console.WriteLine(textData1.Foo(10, "ee", DateTime.Now));
    }
    catch (Microsoft.CSharp.RuntimeBinder.RuntimeBinderException ex)
    {
        Console.WriteLine(ex.Message);
    }
}
```

If you call this method again, you will find the call to `ToUpper()` (note the capital *T* and *U*) works correctly; however, you then find the error data displayed to the console.

```
HELLO
'string' does not contain a definition for 'toupper'
```

Of course, the process of wrapping all dynamic method invocations in a `try/catch` block is rather tedious. As long as you watch your spelling and parameter passing, this is not required. However, catching exceptions is handy when you might not know in advance if a member will be present on the target type.

The Scope of the dynamic Keyword

Recall that implicitly typed data (declared with the `var` keyword) is possible only for local variables in a member scope. The `var` keyword can never be used as a return value, a parameter, or a member of a class/structure. This is not the case with the `dynamic` keyword, however. Consider the following class definition:

```
class VeryDynamicClass
{
    // A dynamic field.
    private static dynamic myDynamicField;

    // A dynamic property.
    public dynamic DynamicProperty { get; set; }
}
```



```

// A dynamic return type and a dynamic parameter type.
public dynamic DynamicMethod(dynamic dynamicParam)
{
    // A dynamic local variable.
    dynamic dynamicLocalVar = "Local variable";

    int myInt = 10;

    if (dynamicParam is int)
    {
        return dynamicLocalVar;
    }
    else
    {
        return myInt;
    }
}
}

```

You could now invoke the public members as expected; however, as you are operating on dynamic methods and properties, you cannot be completely sure what the data type will be! To be sure, the `VeryDynamicClass` definition might not be useful in a real-world application, but it does illustrate the scope of where you can apply this C# keyword.

Limitations of the dynamic Keyword

While a great many things can be defined using the `dynamic` keyword, there are some limitations regarding its usage. While they are not showstoppers, do know that a dynamic data item cannot make use of lambda expressions or C# anonymous methods when calling a method. For example, the following code will always result in errors, even if the target method does indeed take a delegate parameter that takes a string value and returns void:

```

dynamic a = GetDynamicObject();

// Error! Methods on dynamic data can't use lambdas!
a.Method(arg => Console.WriteLine(arg));

```

To circumvent this restriction, you will need to work with the underlying delegate directly, using the techniques described in Chapter 10. Another limitation is that a dynamic point of data cannot understand any extension methods (see Chapter 11). Unfortunately, this would also include any of the extension methods that come from the LINQ APIs. Therefore, a variable declared with the `dynamic` keyword has limited use within LINQ to Objects and other LINQ technologies.

```

dynamic a = GetDynamicObject();

// Error! Dynamic data can't find the Select() extension method!
var data = from d in a select d;

```

Practical Uses of the dynamic Keyword

Given that dynamic data is not strongly typed, not checked at compile time, has no ability to trigger IntelliSense, and cannot be the target of a LINQ query, you are absolutely correct to assume that using the dynamic keyword just for the sake of doing so is a poor programming practice.

However, in a few circumstances, the dynamic keyword can radically reduce the amount of code you need to author by hand. Specifically, if you are building a .NET application that makes heavy use of late binding (via reflection), the dynamic keyword can save you typing time. As well, if you are building a .NET application that needs to communicate with legacy COM libraries (such as Microsoft Office products), you can greatly simplify your code base via the dynamic keyword. By way of a final example, web sites built using the MVC design pattern frequently use the ViewBag type, which can also be accessed in a simplified manner using the dynamic keyword.

Like any “shortcut,” you need to weigh the pros and cons. The use of the dynamic keyword is a trade-off between brevity of code and type safety. While C# is a strongly typed language at its core, you can opt in (or opt out) of dynamic behaviors on a call-by-call basis. Always remember that you never need to use the dynamic keyword. You could always get to the same end result by authoring alternative code by hand (and typically much more of it).

■ **Source Code** The DynamicKeyword project is located in the Chapter 16 subdirectory.

The Role of the Dynamic Language Runtime

Now that you better understand what “dynamic data” is all about, let’s learn how it is processed. Since the release of .NET 4.0, the Common Language Runtime (CLR) was supplemented with a complementary runtime environment named the Dynamic Language Runtime. The concept of a “dynamic runtime” is certainly not new. In fact, many programming languages such as JavaScript, LISP, Ruby, and Python have used it for years. In a nutshell, a dynamic runtime allows a dynamic language the ability to discover types completely at runtime with no compile-time checks.

If you have a background in strongly typed languages (including C#, without dynamic types), the notion of such a runtime might seem undesirable. After all, you typically want to receive compile-time errors, not runtime errors, wherever possible. Nevertheless, dynamic languages/runtimes do provide some interesting features, including the following:

- An extremely flexible code base. You can refactor code without making numerous changes to data types.
- A simple way to interoperate with diverse object types built in different platforms and programming languages.
- A way to add or remove members to a type, in memory, at runtime.

One role of the DLR is to enable various dynamic languages to run with the .NET runtime and give them a way to interoperate with other .NET code. Two popular dynamic languages that make use of the DLR are IronPython and IronRuby. These languages live in a dynamic universe, where type is discovered solely at runtime. And yet, these languages have access to the richness of the .NET base class libraries. Even better, their code bases can interoperate with C# (or vice versa), thanks to the inclusion of the dynamic keyword.

■ **Note** This chapter will not address how the DLR can be used to integrate with dynamic languages. However, you can find details at the IronPython (<http://ironpython.codeplex.com>) and IronRuby (<http://rubyforge.org/projects/ironruby>) web sites.

The Role of Expression Trees

The DLR makes use of *expression trees* to capture the meaning of a dynamic call in neutral terms. For example, when the DLR encounters some C# code, such as the following:

```
dynamic d = GetSomeData();
d.SuperMethod(12);
```

it will automatically build an expression tree that says, in effect, “Call the method named `SuperMethod` on object `d`, passing in the number 12 as an argument.” This information (formally termed the *payload*) is then passed to the correct runtime binder, which again could be the C# dynamic binder, the IronPython dynamic binder, or even (as explained shortly) legacy COM objects.

From here, the request is mapped into the required call structure for the target object. The nice thing about these expression trees (beyond that you don’t need to manually create them) is that this allows you to write a fixed C# code statement and not worry about what the underlying target actually is (COM object, IronPython, IronRuby code base, etc.). Figure 16-2 illustrates the concept of expression trees from a high level.

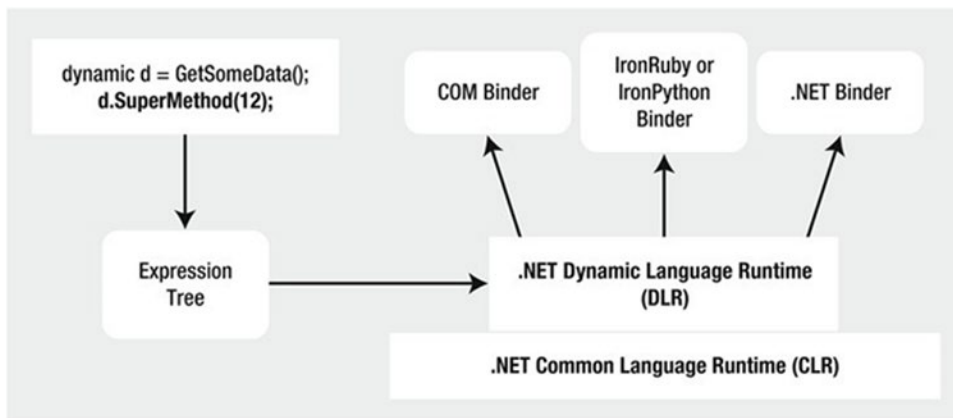

Figure 16-2. Expression trees capture dynamic calls in neutral terms and are processed by binders

The Role of the System.Dynamic Namespace

The `System.Core.dll` assembly includes a namespace named `System.Dynamic`. Truth be told, the chances are quite high that you will never need to use the types located here. However, if you were a language vendor, who wanted to enable their dynamic languages to interact with the DLR, you could make use of the `System.Dynamic` namespace to build a custom runtime binder.

Again, you won’t need to directly dig into the types of `System.Dynamic` in this book; however, feel free to check it out using the .NET Framework 4.6 SDK documentation if you are interested. For practical purposes, simply know that this namespace provides the necessary infrastructure to make a dynamic language “NET aware.”

Dynamic Runtime Lookup of Expression Trees

As explained, the DLR will pass the expression trees to a target object; however, this dispatching will be influenced by a few factors. If the dynamic data type is pointing in memory to a COM object, the expression tree is sent to a low-level COM interface named `IDispatch`. As you might know, this interface was COM's way of incorporating its own set of dynamic services. COM objects, however, can be used in a .NET application without the use of the DLR or C# dynamic keyword. Doing so, however (as you will see), tends to result in much more complex C# coding.

If the dynamic data is not pointing to a COM object, the expression tree may be passed to an object implementing the `IDynamicObject` interface. This interface is used behind the scenes to allow a language, such as IronRuby, to take a DLR expression tree and map it to Ruby specifics.

Finally, if the dynamic data is pointing to an object that is *not* a COM object and does *not* implement `IDynamicObject`, the object is a normal, everyday .NET object. In this case, the expression tree is dispatched to the C# runtime binder for processing. The process of mapping the expression tree to .NET specifics involves reflection services.

After the expression tree has been processed by a given binder, the dynamic data will be resolved to the real in-memory data type, after which the correct method is called with any necessary parameters. Now, let's see a few practical uses of the DLR, beginning with the simplification of late-bound .NET calls.

Simplifying Late-Bound Calls Using Dynamic Types

One instance where you might decide to use the `dynamic` keyword is when you are working with reflection services, specifically when making late-bound method calls. In Chapter 15, you saw a few examples of when this type of method call can be useful, most commonly when you are building some type of extensible application. At that time, you learned how to use the `Activator.CreateInstance()` method to create an object, for which you have no compile-time knowledge of (beyond its display name). You can then make use of the types of the `System.Reflection` namespace to invoke members via late binding. Recall the following example from Chapter 15:

```
static void CreateUsingLateBinding(Assembly asm)
{
    try
    {
        // Get metadata for the Minivan type.
        Type miniVan = asm.GetType("CarLibrary.Minivan");

        // Create the Minivan on the fly.
        object obj = Activator.CreateInstance(miniVan);

        // Get info for TurboBoost.
        MethodInfo mi = miniVan.GetMethod("TurboBoost");

        // Invoke method ("null" for no parameters).
        mi.Invoke(obj, null);
    }
    catch (Exception ex)
    {
        Console.WriteLine(ex.Message);
    }
}
```

While this code works as expected, you might agree it is a bit clunky. Here, you have to manually make use of the `MethodInfo` class, manually query the metadata, and so forth. The following is a version of this same method, now using the C# dynamic keyword and the DLR:

```
static void InvokeMethodWithDynamicKeyword(Assembly asm)
{
    try
    {
        // Get metadata for the Minivan type.
        Type miniVan = asm.GetType("CarLibrary.Minivan");

        // Create the Minivan on the fly and call method!
        dynamic obj = Activator.CreateInstance(miniVan);
        obj.TurboBoost();
    }
    catch (Exception ex)
    {
        Console.WriteLine(ex.Message);
    }
}
```

By declaring the `obj` variable using the dynamic keyword, the heavy lifting of reflection is done on your behalf, courtesy of the DRL.

Leveraging the dynamic Keyword to Pass Arguments

The usefulness of the DLR becomes even more obvious when you need to make late-bound calls on methods that take parameters. When you use “longhand” reflection calls, arguments need to be packaged up as an array of objects, which are passed to the `Invoke()` method of `MethodInfo`.

To illustrate using a fresh example, begin by creating a new C# Console Application project named `LateBindingWithDynamic`. Next, add a Class Library project to the current solution (using the File ► Add ► New Project menu option) named `MathLibrary`. Rename the initial `Class1.cs` file of the `MathLibrary` project to `SimpleMath.cs`, and implement the class like so:

```
public class SimpleMath
{
    public int Add(int x, int y)
    {
        return x + y;
    }
}
```

After you have compiled your `MathLibrary.dll` assembly, place a copy of this library in the `\bin\Debug` folder of the `LateBindingWithDynamic` project. (If you click the Show All Files button for each project of the Solution Explorer, you can simply drag and drop the file between projects.) At this point, your Solution Explorer should look something like Figure 16-3.

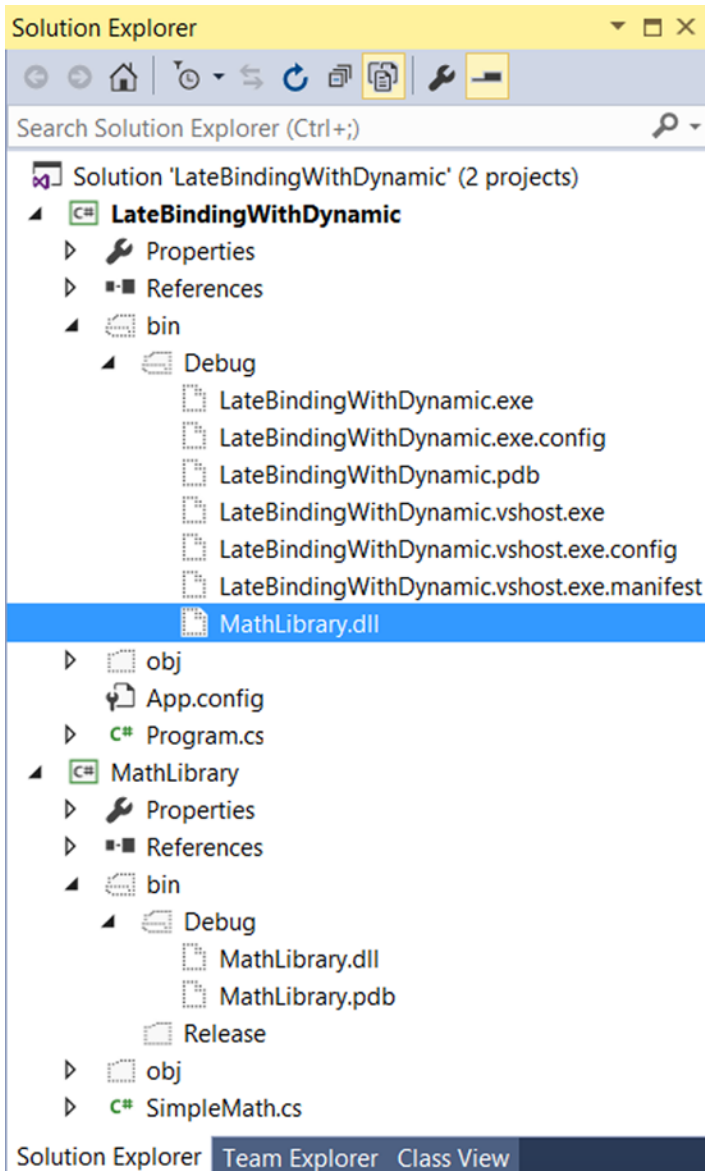

Figure 16-3. The *LateBindingWithDynamic* project has a private copy of *MathLibrary.dll*

■ **Note** Remember, the whole point of late binding is to allow an application to create an object for which it has no record of in the manifest. This is why you manually copied *MathLibrary.dll* into the output folder of the Console project, rather than reference the assembly using Visual Studio.

Now, import the `System.Reflection` namespace into the `Program.cs` file of your Console Application project. Next, add the following method to the `Program` class, which invokes the `Add()` method using typical reflection API calls:

```
private static void AddWithReflection()
{
    Assembly asm = Assembly.Load("MathLibrary");
    try
    {
        // Get metadata for the SimpleMath type.
        Type math = asm.GetType("MathLibrary.SimpleMath");

        // Create a SimpleMath on the fly.
        object obj = Activator.CreateInstance(math);

        // Get info for Add.
        MethodInfo mi = math.GetMethod("Add");

        // Invoke method (with parameters).
        object[] args = { 10, 70 };
        Console.WriteLine("Result is: {0}", mi.Invoke(obj, args));
    }
    catch (Exception ex)
    {
        Console.WriteLine(ex.Message);
    }
}
```

Now, consider the simplification of the previous logic with the dynamic keyword, via the following new method:

```
private static void AddWithDynamic()
{
    Assembly asm = Assembly.Load("MathLibrary");

    try
    {
        // Get metadata for the SimpleMath type.
        Type math = asm.GetType("MathLibrary.SimpleMath");

        // Create a SimpleMath on the fly.
        dynamic obj = Activator.CreateInstance(math);

        // Note how easily we can now call Add().
        Console.WriteLine("Result is: {0}", obj.Add(10, 70));
    }
    catch (Microsoft.CSharp.RuntimeBinder.RuntimeBinderException ex)
    {
        Console.WriteLine(ex.Message);
    }
}
```

Not too shabby! If you call both methods from the `Main()` method, you'll see identical output. However, when using the `dynamic` keyword, you saved yourself quite a bit of work. With dynamically defined data, you no longer need to manually package up arguments as an array of objects, query the assembly metadata, or other such details. If you are building an application that makes heavy use of dynamic loading/late binding, I am sure you can see how these code savings would add up over time.

■ **Source Code** The `LateBindingWithDynamic` project is included in the Chapter 16 subdirectory.

Simplifying COM Interoperability Using Dynamic Data

Let's see another useful case for the `dynamic` keyword within the context of a COM interoperability project. Now, if you don't have much background in COM development, do be aware for this next example that a compiled COM library contains metadata, just like a .NET library; however, the format is completely different. Because of this, if a .NET program needs to communicate with a COM object, the first order of business is to generate what is known as an *interop assembly* (described in the following paragraphs). Doing so is quite straightforward. Just activate the Add Reference dialog box, select the COM tab, and find the COM library you want to use (see Figure 16-4).

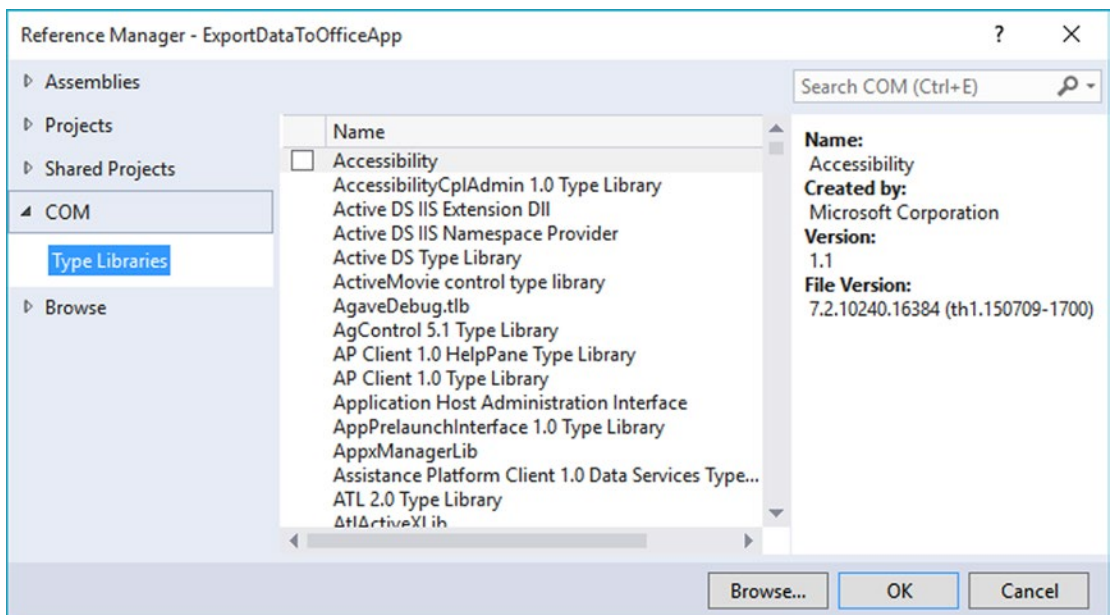

Figure 16-4. The COM tab of the Add Reference dialog box will show you all registered COM libraries on your machine

■ **Note** Be aware that several important Microsoft object models (including Office products) are currently accessible only through COM interoperability. Thus, even if you do not have direct experience building COM applications, you might need to consume them from a .NET program.

Once you select a COM library, the IDE will respond by generating a new assembly that contains .NET descriptions of COM metadata. Formally speaking, these are termed *interop assemblies* (or simply, *interop assemblies*). Interop assemblies do not contain any implementation code, except for a small amount that helps translate COM events to .NET events. However, these interop assemblies are useful in that they shield your .NET code base from the complex underbelly of COM internals.

In your C# code, you can directly program against the interop assembly, allowing the CLR (and if you use the `dynamic` keyword, the DLR) to automatically map .NET data types into COM types, and vice versa. Behind the scenes, data is marshaled between the .NET and COM applications using a Runtime Callable Wrapper (RCW), which is basically a dynamically generated proxy. This RCW proxy will marshal and transform .NET data types into COM types and map any COM return values into .NET equivalents.

Figure 16-5 shows the big picture of .NET to COM interoperability.

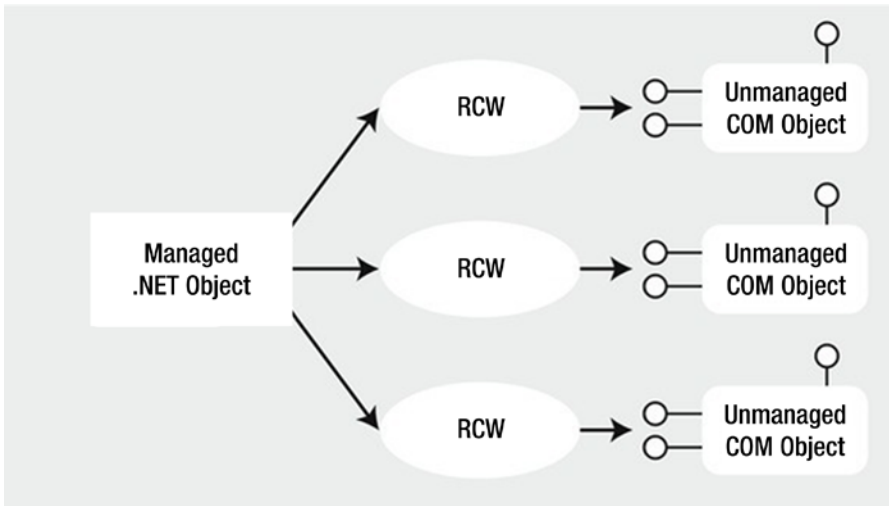

Figure 16-5. .NET programs communicate with COM objects using a proxy termed the RCW

The Role of Primary Interop Assemblies

Many COM libraries created by COM library vendors (such as the Microsoft COM libraries that allow access to the object model of Microsoft Office products) provide an “official” interoperability assembly termed a *primary interop assembly* (PIA). PIAs are optimized interop assemblies, which clean up (and possibly extend) the code typically generated when referencing a COM library using the Add Reference dialog box.

PIAs are typically listed in the Assemblies section of the Add Reference dialog box (under the Extensions subarea). In fact, if you reference a COM library from the COM tab of the Add Reference dialog box, Visual Studio will not generate a new interoperability library as it would normally do but would use the provided PIA instead. Figure 16-6 shows the PIA of the Microsoft Office Excel object model, which you will be using in the next example.

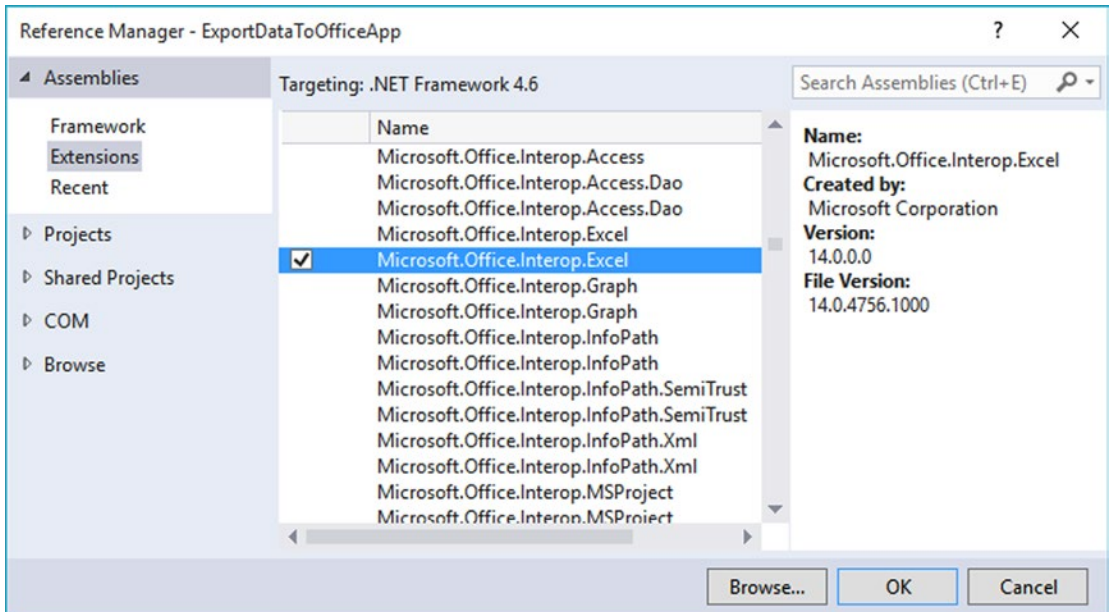

Figure 16-6. PIAs are listed on the .NET tab of the Add Reference dialog box

Embedding Interop Metadata

Before the release of .NET 4.0, when a C# application made use of a COM library (PIA or not), you needed to ensure the client machine had a copy of the interop assembly on their computer. Not only did this increase the size of your application installer package, but the install script had to check that the PIA assemblies were indeed present and, if not, install a copy to the GAC.

However, under .NET 4.0 and higher, you can now elect to embed the interoperability data directly within your compiled .NET application. When you do so, you are no longer required to ship a copy of the interoperability assembly along with your .NET application, as the necessary interoperability metadata is hard-coded in the .NET program.

By default, when you select a COM library (PIA or not) using the Add References dialog, the IDE will automatically set the Embed Interop Types property of the library to True. You can see this setting first hand by selecting a referenced interop library in the References folder of the Solution Explorer and then investigating the Properties window (see Figure 16-7).

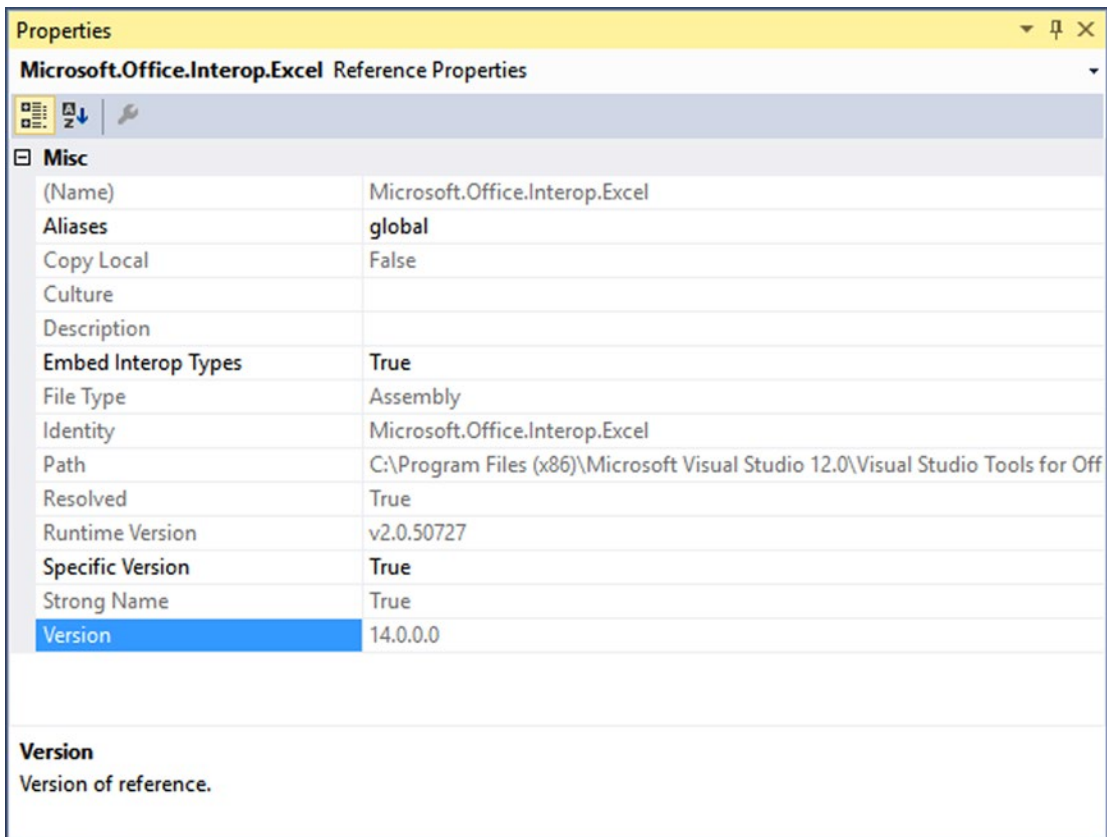

Figure 16-7. Interop assembly logic can be embedded directly into your .NET application

The C# compiler will include only the parts of the interop library you are actually using. Thus, if the real interop library has .NET descriptions of hundreds of COM objects, you will bring in only the definitions of the subset you are really using in your C# code. Beyond reducing the size of the application you need to ship to the client, you also have an easier installation path, as you don't need to install any missing PIAs on the target machine.

Common COM Interop Pain Points

Let's cover one more preliminary topic before the next example. Before the release of the DLR, when you authored C# code that used a COM library (via the interop assembly), you were sure to face a number of challenges. For example, many COM libraries defined methods that took optional arguments, which were not supported in C# until .NET 3.5. This required you to specify the value `Type.Missing` for every occurrence of the optional argument. For example, if a COM method took five arguments, all of which were optional, you would need to write the following C# code in order to accept the default values:

```
myComObj.SomeMethod(Type.Missing, Type.Missing, Type.Missing, Type.Missing, Type.Missing);
```

Thankfully, you are now able to author the following simplified code, given that the `Type.Missing` values will be inserted at compile time if you don't specify a specific value:

```
myComObj.SomeMethod();
```

On a related note, many COM methods provided support for named arguments, which as you recall from Chapter 4, allows you to pass values to members in any order you require. Given that C# supports this same feature, it is simply to “skip” over a set of optional arguments you don't care about and set only the few you do.

Another common COM interop pain point has to do with the fact that many COM methods were designed to take and return a particular data type, termed the `Variant`. Much like the C# `dynamic` keyword, a `Variant` data type could be assigned to any type of COM data on the fly (strings, interface references, numerical values, etc.). Before you had the `dynamic` keyword, passing or receiving `Variant` data points required some hoop jumping, typically by way of numerous casting operations.

When you set the `Embed Interop Types` property to `True`, all COM `Variant` types are automatically mapped to dynamic data. This will not only reduce the need to extraneous casting operations when working with underlying COM `Variant` data types but will also further hide some COM complexities, such as working with COM indexers.

To showcase how C# optional arguments, named arguments, and the `dynamic` keyword all work together to simplify COM interop, you will now build an application that uses the Microsoft Office object model. As you work through the example, you will get a chance to use the new features, as well as forgo them, and then compare and contrast the workload.

■ **Note** If you do not have a background in Windows Forms, you might want to simply load the completed solution into Visual Studio and experiment with the code, rather than build this application by hand.

COM Interop Using C# Dynamic Data

Assume you have a Windows Forms GUI application (named `ExportDataToOfficeApp`), whose main window hosts a `DataGridView` control named `dataGridCars`. This same window has two `Button` controls, the first of which will bring up a custom dialog box to insert a new row of data to the grid, and the other of which will export the grid's data to an Excel spreadsheet. Figure 16-8 shows the completed GUI.

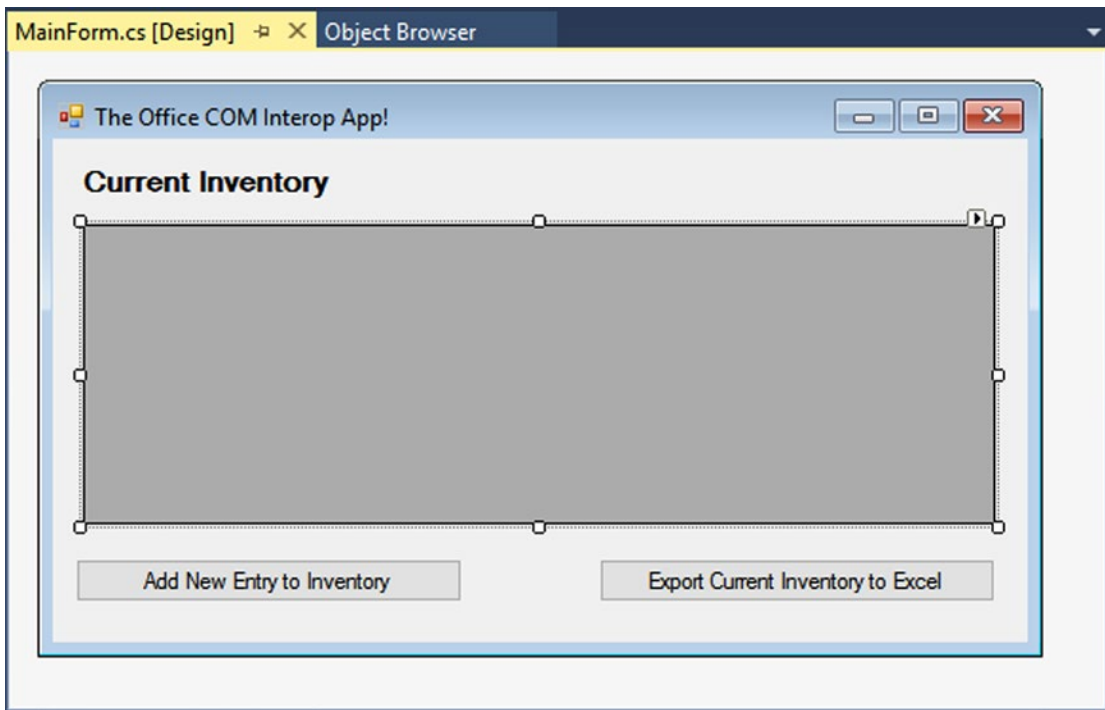

Figure 16-8. The GUI of the COM interop example

The DataGridView control is filled with some initial data by handling the form's Load event as so (the Car class used as the type parameter for the generic List<T> is a simple class in the project with Color, Make, and PetName properties):

```
public partial class MainForm : Form
{
    List<Car> carsInStock = null;

    public MainForm()
    {
        InitializeComponent();
    }

    private void MainForm_Load(object sender, EventArgs e)
    {
        carsInStock = new List<Car>
        {
            new Car {Color="Green", Make="VW", PetName="Mary"},
            new Car {Color="Red", Make="Saab", PetName="Mel"},
            new Car {Color="Black", Make="Ford", PetName="Hank"},
            new Car {Color="Yellow", Make="BMW", PetName="Davie"}
        };
    }
}
```

```

        UpdateGrid();
    }

    private void UpdateGrid()
    {
        // Reset the source of data.
        dataGridCars.DataSource = null;
        dataGridCars.DataSource = carsInStock;
    }
}

```

The Click event for the Add New Entry to Inventory button will launch a custom dialog box to allow the user to enter new data for a Car object, and if the user clicks the OK button, the data is added to the grid (I won't bother to show the code behind the dialog box here, so please see the provided solution for details). If you are following along, however, include the `NewCarDialog.cs`, `NewCarDialog.designer.cs`, and `NewCarDialog.resx` files into your project (all of which are part of the code download for this text). After you have done so, implement the Add button click handler on the main window, as so:

```

private void btnAddNewCar_Click(object sender, EventArgs e)
{
    NewCarDialog d = new NewCarDialog();
    if (d.ShowDialog() == DialogResult.OK)
    {
        // Add new car to list.
        carsInStock.Add(d.theCar);
        UpdateGrid();
    }
}

```

The Click event handler for the Export Current Inventory to Excel button is the heart of this example. Using the Add Reference dialog box, add a reference to the `Microsoft.Office.Interop.Excel.dll` primary interop assembly (as shown previously in Figure 16-7). Add the following namespace alias to the form's primary code file. Be aware that this is not mandatory to define an alias when interacting with COM libraries. However, by doing so, you have a handy qualifier for all the imported COM objects, which is handy if some of these COM objects have names that would clash with your .NET types.

```

// Create an alias to the Excel object model.
using Excel = Microsoft.Office.Interop.Excel;

```

Implement this button Click event handler to call a private helper function named `ExportToExcel()`, like so:

```

private void btnExportToExcel_Click(object sender, EventArgs e)
{
    ExportToExcel(carsInStock);
}

```

Because you imported the COM library using Visual Studio, the PIA has been automatically configured so that the used metadata will be embedded into the .NET application (recall the role of the Embed Interop Types property). Therefore, all COM Variants are realized as dynamic data types. Furthermore, you can use C# optional arguments and named arguments. This being said, consider the following implementation of `ExportToExcel()`:

```
static void ExportToExcel(List<Car> carsInStock)
{
    // Load up Excel, then make a new empty workbook.
    Excel.Application excelApp = new Excel.Application();
    excelApp.Workbooks.Add();

    // This example uses a single workSheet.
    Excel._Worksheet workSheet = excelApp.ActiveSheet;

    // Establish column headings in cells.
    workSheet.Cells[1, "A"] = "Make";
    workSheet.Cells[1, "B"] = "Color";
    workSheet.Cells[1, "C"] = "Pet Name";

    // Now, map all data in List<Car> to the cells of the spreadsheet.
    int row = 1;
    foreach (Car c in carsInStock)
    {
        row++;
        workSheet.Cells[row, "A"] = c.Make;
        workSheet.Cells[row, "B"] = c.Color;
        workSheet.Cells[row, "C"] = c.PetName;
    }

    // Give our table data a nice look and feel.
    workSheet.Range["A1"].AutoFormat(
        Excel.XlRangeAutoFormat.xlRangeAutoFormatClassic2);

    // Save the file, quit Excel, and display message to user.
    workSheet.SaveAs(string.Format(@"{0}\Inventory.xlsx", Environment.CurrentDirectory));
    excelApp.Quit();
    MessageBox.Show("The Inventory.xlsx file has been saved to your app folder",
        "Export complete!");
}
```

This method begins by loading Excel into memory; however, you won't see it visible on your computer desktop. For this application, you are interested only in using the internal Excel object model. However, if you do want to actually display the UI of Excel, update your method with this additional line of code:

```
static void ExportToExcel(List<Car> carsInStock)
{
    // Load up Excel, then make a new empty workbook.
    Excel.Application excelApp = new Excel.Application();

    // Go ahead and make Excel visible on the computer.
    excelApp.Visible = true;
    ...
}
```

After you create an empty worksheet, you add three columns that are named similar to the properties of the Car class. Then, you fill the cells with the data of the `List<Car>` and save your file under the (hard-coded) name `Inventory.xlsx`.

At this point, if you run your application, add a few new records, and export your data to Excel, you will then be able to open the `Inventory.xlsx` file, which will be saved to the `\bin\Debug` folder of your Windows Forms application. Figure 16-9 shows a possible export.

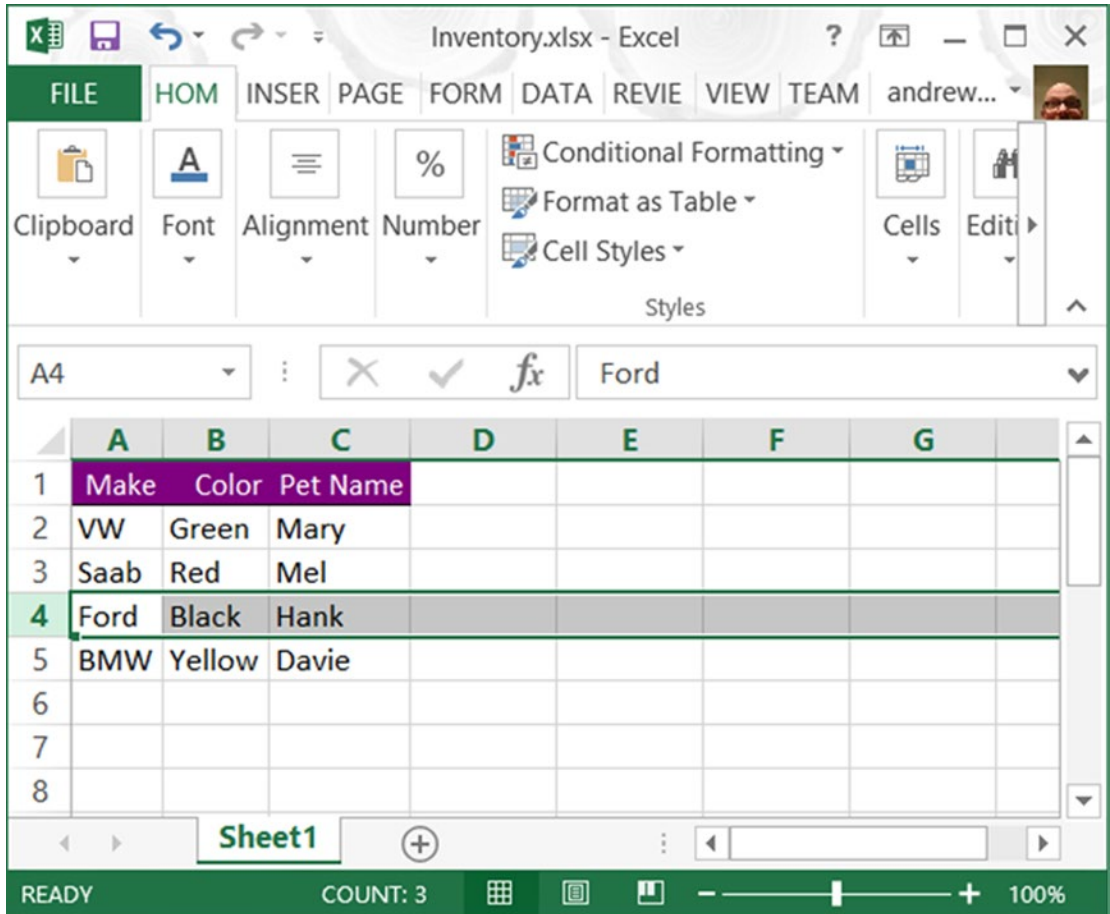

Figure 16-9. Exporting your data to an Excel file

COM interop Without C# Dynamic Data

Now, if you were to select the `Microsoft.Office.Interop.Excel.dll` assembly (in Solution Explorer) and set its `Embed Interop Type` property to `False`, you would have new compiler errors, as the COM Variant data is no longer realized as dynamic data but as `System.Object` variables. This will require you to update `ExportToExcel()` with a number of explicit casting operations.

As well, if this project were compiled under .NET 3.5 or earlier, you would no longer have the benefit of optional/named parameters and would have to explicitly mark all missing arguments. Here is a version of the `ExportToExcel()` method that would be required in earlier versions of C# (do note the increased complexity in code):

```
static void ExportToExcel2008(List<Car> carsInStock)
{
    Excel.Application excelApp = new Excel.Application();

    // Must mark missing params!
    excelApp.Workbooks.Add(Type.Missing);

    // Must cast Object as _Worksheet!
    Excel._Worksheet workSheet = (Excel._Worksheet)excelApp.ActiveSheet;

    // Must cast each Object as Range object then
    // call low-level Value2 property!
    ((Excel.Range)excelApp.Cells[1, "A"]).Value2 = "Make";
    ((Excel.Range)excelApp.Cells[1, "B"]).Value2 = "Color";
    ((Excel.Range)excelApp.Cells[1, "C"]).Value2 = "Pet Name";

    int row = 1;
    foreach (Car c in carsInStock)
    {
        row++;
        // Must cast each Object as Range and call low-level Value2 prop!
        ((Excel.Range)workSheet.Cells[row, "A"]).Value2 = c.Make;
        ((Excel.Range)workSheet.Cells[row, "B"]).Value2 = c.Color;
        ((Excel.Range)workSheet.Cells[row, "C"]).Value2 = c.PetName;
    }

    // Must call get_Range method and then specify all missing args!
    excelApp.get_Range("A1", Type.Missing).AutoFormat(
        Excel.XlRangeAutoFormat.xlRangeAutoFormatClassic2,
        Type.Missing, Type.Missing, Type.Missing,
        Type.Missing, Type.Missing, Type.Missing);

    // Must specify all missing optional args!
    workSheet.SaveAs(string.Format(@"{0}\Inventory.xlsx", Environment.CurrentDirectory),
        Type.Missing, Type.Missing, Type.Missing, Type.Missing, Type.Missing, Type.Missing,
        Type.Missing, Type.Missing, Type.Missing);

    excelApp.Quit();
    MessageBox.Show("The Inventory.xlsx file has been saved to your app folder",
        "Export complete!");
}
```

Although the end result of running this program is identical, this version of the method is much more verbose, as I am sure you agree. That wraps up your look at the C# `dynamic` keyword and the DLR. I hope you can see how these features can simplify complex programming tasks and (perhaps more importantly) understand the trade-offs. When you opt into dynamic data, you do lose a good amount of type safety, and your code base is prone to many more runtime errors.

While there is certainly more to say about the DLR, this chapter has tried to focus on topics that are practical and useful in your day-to-day programming. If you want to learn more about advanced features of the Dynamic Language Runtime, such as integrating with scripting languages, be sure to consult the .NET Framework 4.6 SDK documentation (look up the topic “Dynamic Language Runtime Overview” to get started).

■ **Source Code** The `ExportDataToOfficeApp` project is included in the [Chapter 16](#) subdirectory.

Summary

The `dynamic` keyword introduced in C# 4.0 allows you to define data whose true identity is not known until runtime. When processed by the new Dynamic Language Runtime, the automatically created “expression tree” will be passed to the correct dynamic language binder, where the payload will be unpackaged and sent to the correct object member.

Using dynamic data and the DLR, a number of complex C# programming tasks can be radically simplified, especially the act of incorporating COM libraries into your .NET applications. As you have also seen in this chapter, .NET 4.0 and higher provides a number of further simplifications to COM interop (which have nothing to do with dynamic data), such as embedding COM interop data into your applications, optional arguments, and named arguments.

While these features can certainly simplify your code, always remember that dynamic data makes your C# code much less type safe and open to runtime errors. Be sure you weigh the pros and cons of using dynamic data in your C# projects, and test accordingly!

CHAPTER 17



Processes, AppDomains, and Object Contexts

In Chapters 14 and 15, you examined the steps taken by the CLR to resolve the location of a referenced external assembly, as well as the role of .NET metadata. In this chapter, you'll drill deeper into the details of how an assembly is hosted by the CLR and come to understand the relationship between processes, application domains, and object contexts.

In a nutshell, *application domains* (or simply *AppDomains*) are logical subdivisions within a given process that host a set of related .NET assemblies. As you will see, an AppDomain is further subdivided into *contextual boundaries*, which are used to group like-minded .NET objects. Using the notion of context, the CLR is able to ensure that objects with special runtime requirements are handled appropriately.

While it is true that many of your day-to-day programming tasks might not involve directly working with processes, AppDomains, or object contexts, understanding these topics is important when working with numerous .NET APIs, including Windows Communication Foundation (WCF), multithreading and parallel processing, and object serialization.

The Role of a Windows Process

The concept of a “process” existed within Windows-based operating systems well before the release of the .NET platform. In simple terms, a *process* is a running program. However, formally speaking, a process is an operating system–level concept used to describe a set of resources (such as external code libraries and the primary thread) and the necessary memory allocations used by a running application. For each *.exe loaded into memory, the OS creates a separate and isolated process for use during its lifetime.

Using this approach to application isolation, the result is a much more robust and stable runtime environment, given that the failure of one process does not affect the functioning of another. Furthermore, data in one process cannot be directly accessed by another process, unless you make use of a distributed computing programming API such as Windows Communication Foundation. Given these points, you can regard the process as a fixed, safe boundary for a running application.

Now, every Windows process is assigned a unique process identifier (PID) and may be independently loaded and unloaded by the OS as necessary (as well as programmatically). As you might be aware, the Processes tab of the Windows Task Manager utility (activated via the Ctrl+Shift+Esc keystroke combination) allows you to view various statistics regarding the processes running on a given machine. The Details tab allows you to view the assigned PID and image name (see Figure 17-1).

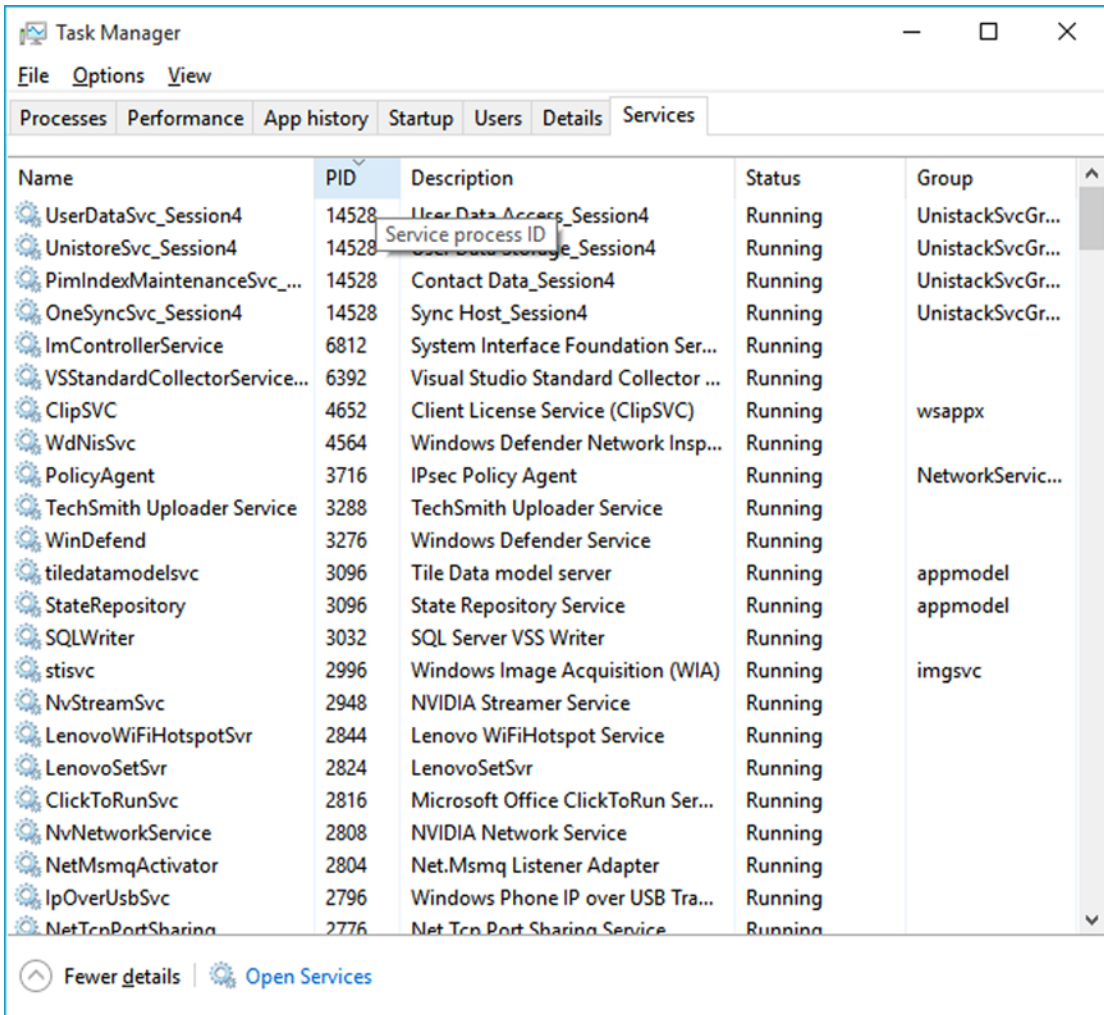

Figure 17-1. The Windows Task Manager

■ **Note** In Windows 10, you can view the PID of a process on the Services tab.

The Role of Threads

Every Windows process contains an initial “thread” that functions as the entry point for the application. Chapter 19 examines the details of building multithreaded applications under the .NET platform; however, to facilitate the topics presented here, you need a few working definitions. First, a *thread* is a path of execution within a process. Formally speaking, the first thread created by a process’s entry point is termed the *primary thread*. Any .NET executable program (Console Application, Windows service, WPF application, etc.) marks its entry point with the `Main()` method. When this method is invoked, the primary thread is created automatically.

Processes that contain a single primary thread of execution are intrinsically *thread safe*, given the fact that there is only one thread that can access the data in the application at a given time. However, a single-threaded process (especially one that is GUI-based) will often appear a bit unresponsive to the user if this single thread is performing a complex operation (such as printing out a lengthy text file, performing a mathematically intensive calculation, or attempting to connect to a remote server located thousands of miles away).

Given this potential drawback of single-threaded applications, the Windows API (as well as the .NET platform) makes it possible for the primary thread to spawn additional secondary threads (also termed *worker threads*) using a handful of Windows API functions such as `CreateThread()`. Each thread (primary or secondary) becomes a unique path of execution in the process and has concurrent access to all shared points of data within the process.

As you might have guessed, developers typically create additional threads to help improve the program's overall responsiveness. Multithreaded processes provide the illusion that numerous activities are happening at more or less the same time. For example, an application may spawn a worker thread to perform a labor-intensive unit of work (again, such as printing a large text file). As this secondary thread is churning away, the main thread is still responsive to user input, which gives the entire process the potential of delivering greater performance. However, this may not actually be the case: using too many threads in a single process can actually *degrade* performance, as the CPU must switch between the active threads in the process (which takes time).

On some machines, multithreading is most commonly an illusion provided by the OS. Machines that host a single (non-hyperthreaded) CPU do not have the ability to literally handle multiple threads at the same time. Rather, a single CPU will execute one thread for a unit of time (called a *time slice*) based in part on the thread's priority level. When a thread's time slice is up, the existing thread is suspended to allow another thread to perform its business. For a thread to remember what was happening before it was kicked out of the way, each thread is given the ability to write to Thread Local Storage (TLS) and is provided with a separate call stack, as illustrated in Figure 17-2.

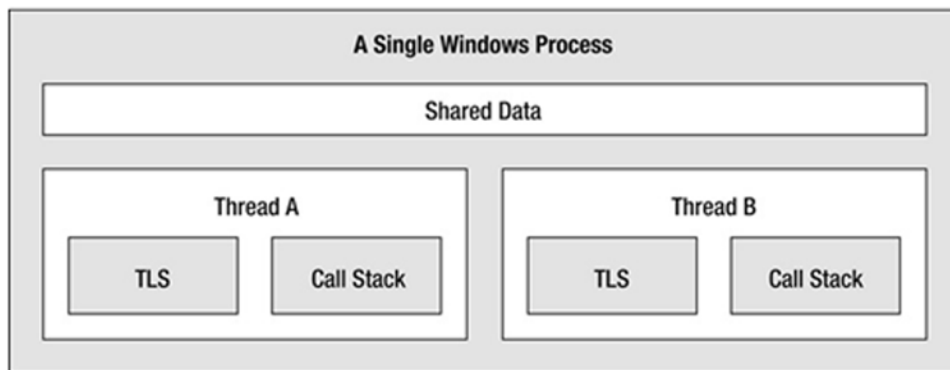

Figure 17-2. The Windows process/thread relationship

If the subject of threads is new to you, don't sweat the details. At this point, just remember that a thread is a unique path of execution within a Windows process. Every process has a primary thread (created via the executable's entry point) and may contain additional threads that have been programmatically created.

Interacting with Processes Under the .NET Platform

Although processes and threads are nothing new, the manner in which you interact with these primitives under the .NET platform has changed quite a bit (for the better). To pave the way to understanding the world of building multithreaded assemblies (see Chapter 19), let's begin by checking out how to interact with processes using the .NET base class libraries.

The `System.Diagnostics` namespace defines a number of types that allow you to programmatically interact with processes and various diagnostic-related types such as the system event log and performance counters. In this chapter, you are concerned with only the process-centric types defined in Table 17-1.

Table 17-1. *Select Members of the System.Diagnostics Namespace*

| Process-Centric Types of the System.Diagnostics Namespace | Meaning in Life |
|---|--|
| <code>Process</code> | The <code>Process</code> class provides access to local and remote processes and also allows you to programmatically start and stop processes. |
| <code>ProcessModule</code> | This type represents a module (*.dll or *.exe) that is loaded into a particular process. Understand that the <code>ProcessModule</code> type can represent <i>any</i> module—COM-based, .NET-based, or traditional C-based binaries. |
| <code>ProcessModuleCollection</code> | This provides a strongly typed collection of <code>ProcessModule</code> objects. |
| <code>ProcessStartInfo</code> | This specifies a set of values used when starting a process via the <code>Process.Start()</code> method. |
| <code>ProcessThread</code> | This type represents a thread within a given process. Be aware that <code>ProcessThread</code> is a type used to diagnose a process's thread set and is not used to spawn new threads of execution within a process. |
| <code>ProcessThreadCollection</code> | This provides a strongly typed collection of <code>ProcessThread</code> objects. |

The `System.Diagnostics.Process` class allows you to analyze the processes running on a given machine (local or remote). The `Process` class also provides members that allow you to programmatically start and terminate processes, view (or modify) a process's priority level, and obtain a list of active threads and/or loaded modules within a given process. Table 17-2 lists some of the key properties of `System.Diagnostics.Process`.

Table 17-2. *Select Properties of the Process Type*

| Property | Meaning in Life |
|-----------------|---|
| ExitTime | This property gets the timestamp associated with the process that has terminated (represented with a <code>DateTime</code> type). |
| Handle | This property returns the handle (represented by an <code>IntPtr</code>) associated to the process by the OS. This can be useful when building .NET applications that need to communicate with unmanaged code. |
| Id | This property gets the PID for the associated process. |
| MachineName | This property gets the name of the computer the associated process is running on. |
| MainWindowTitle | <code>MainWindowTitle</code> gets the caption of the main window of the process (if the process does not have a main window, you receive an empty string). |
| Modules | This property provides access to the strongly typed <code>ProcessModuleCollection</code> type, which represents the set of modules (*.dll or *.exe) loaded within the current process. |
| ProcessName | This property gets the name of the process (which, as you would assume, is the name of the application itself). |
| Responding | This property gets a value indicating whether the user interface of the process is responding to user input (or is currently “hung”). |
| StartTime | This property gets the time that the associated process was started (via a <code>DateTime</code> type). |
| Threads | This property gets the set of threads that are running in the associated process (represented via a collection of <code>ProcessThread</code> objects). |

In addition to the properties just examined, `System.Diagnostics.Process` also defines a few useful methods (see Table 17-3).

Table 17-3. *Select Methods of the Process Type*

| Method | Meaning in Life |
|----------------------------------|--|
| <code>CloseMainWindow()</code> | This method closes a process that has a user interface by sending a close message to its main window. |
| <code>GetCurrentProcess()</code> | This static method returns a new <code>Process</code> object that represents the currently active process. |
| <code>GetProcesses()</code> | This static method returns an array of new <code>Process</code> objects running on a given machine. |
| <code>Kill()</code> | This method immediately stops the associated process. |
| <code>Start()</code> | This method starts a process. |

Enumerating Running Processes

To illustrate the process of manipulating `Process` objects (pardon the redundancy), create a C# Console Application project named `ProcessManipulator` that defines the following static helper method within the `Program` class (be sure you import the `System.Diagnostics` namespace in your code file):

```
static void ListAllRunningProcesses()
{
    // Get all the processes on the local machine, ordered by
    // PID.
    var runningProcs =
        from proc in Process.GetProcesses(".") orderby proc.Id select proc;

    // Print out PID and name of each process.
    foreach(var p in runningProcs)
    {
        string info = string.Format("-> PID: {0}\tName: {1}",
            p.Id, p.ProcessName);
        Console.WriteLine(info);
    }
    Console.WriteLine("*****\n");
}
```

The static `Process.GetProcesses()` method returns an array of `Process` objects that represent the running processes on the target machine (the dot notation shown here represents the local computer). After you have obtained the array of `Process` objects, you are able to invoke any of the members listed in Tables 17-2 and 17-3. Here, you are simply displaying the PID and the name of each process, ordered by PID. Assuming the `Main()` method has been updated to call `ListAllRunningProcesses()` as follows:

```
static void Main(string[] args)
{
    Console.WriteLine("***** Fun with Processes *****\n");
    ListAllRunningProcesses();
    Console.ReadLine();
}
```

you will see the names and PIDs for all processes on your local computer. Here is some partial output from my current machine (your output will most likely be different):

```
***** Fun with Processes *****
-> PID: 0      Name: Idle
-> PID: 4      Name: System
-> PID: 108    Name: iexplore
-> PID: 268    Name: smss
-> PID: 432    Name: csrss
-> PID: 448    Name: svchost
-> PID: 472    Name: wininit
-> PID: 504    Name: csrss
-> PID: 536    Name: winlogon
-> PID: 560    Name: services
```



```

-> PID: 584      Name: lsass
-> PID: 592      Name: lsm
-> PID: 660      Name: devenv
-> PID: 684      Name: svchost
-> PID: 760      Name: svchost
-> PID: 832      Name: svchost
-> PID: 844      Name: svchost
-> PID: 856      Name: svchost
-> PID: 900      Name: svchost
-> PID: 924      Name: svchost
-> PID: 956      Name: VMwareService
-> PID: 1116     Name: spoolsv
-> PID: 1136     Name: ProcessManipulator.vshost
*****

```

Investigating a Specific Process

In addition to obtaining a complete list of all running processes on a given machine, the static `Process.GetProcessById()` method allows you to obtain a single `Process` object via the associated PID. If you request access to a nonexistent PID, an `ArgumentException` exception is thrown. For example, if you were interested in obtaining a `Process` object representing a process with the PID of 987, you could write the following code:

```

// If there is no process with the PID of 987, a
// runtime exception will be thrown.
static void GetSpecificProcess()
{
    Process theProc = null;
    try
    {
        theProc = Process.GetProcessById(987);
    }
    catch(ArgumentException ex)
    {
        Console.WriteLine(ex.Message);
    }
}

```

At this point, you have learned how to get a list of all processes, as well as a specific process on a machine via a PID lookup. While it is somewhat useful to discover PIDs and process names, the `Process` class also allows you to discover the set of current threads and libraries used within a given process. Let's see how to do so.

Investigating a Process's Thread Set

The set of threads is represented by the strongly typed `ProcessThreadCollection` collection, which contains some number of individual `ProcessThread` objects. To illustrate, assume the following additional static helper function has been added to your current application:

```
static void EnumThreadsForPid(int pID)
{
    Process theProc = null;
    try
    {
        theProc = Process.GetProcessById(pID);
    }
    catch(ArgumentException ex)
    {
        Console.WriteLine(ex.Message);
        return;
    }

    // List out stats for each thread in the specified process.
    Console.WriteLine("Here are the threads used by: {0}",
        theProc.ProcessName);
    ProcessThreadCollection theThreads = theProc.Threads;

    foreach(ProcessThread pt in theThreads)
    {
        string info =
            string.Format("-> Thread ID: {0}\tStart Time: {1}\tPriority: {2}",
                pt.Id , pt.StartTime.ToShortTimeString(), pt.PriorityLevel);
        Console.WriteLine(info);
    }
    Console.WriteLine("*****\n");
}
```

As you can see, the `Threads` property of the `System.Diagnostics.Process` type provides access to the `ProcessThreadCollection` class. Here, you are printing the assigned thread ID, start time, and priority level of each thread in the process specified by the client. Now, update your program's `Main()` method to prompt the user for a PID to investigate, as follows:

```
static void Main(string[] args)
{
    ...
    // Prompt user for a PID and print out the set of active threads.
    Console.WriteLine("**** Enter PID of process to investigate ****");
    Console.Write("PID: ");
    string pID = Console.ReadLine();
    int theProcID = int.Parse(pID);

    EnumThreadsForPid(theProcID);
    Console.ReadLine();
}
```

When you run your program, you can now enter the PID of any process on your machine and see the threads used in the process. The following output shows the threads used by PID 108 on my machine, which happens to be hosting Microsoft Internet Explorer:

```

***** Enter PID of process to investigate *****
PID: 108
Here are the threads used by: iexplore
-> Thread ID: 680      Start Time: 9:05 AM      Priority: Normal
-> Thread ID: 2040     Start Time: 9:05 AM      Priority: Normal
-> Thread ID: 880      Start Time: 9:05 AM      Priority: Normal
-> Thread ID: 3380     Start Time: 9:05 AM      Priority: Normal
-> Thread ID: 3376     Start Time: 9:05 AM      Priority: Normal
-> Thread ID: 3448     Start Time: 9:05 AM      Priority: Normal
-> Thread ID: 3476     Start Time: 9:05 AM      Priority: Normal
-> Thread ID: 2264     Start Time: 9:05 AM      Priority: Normal
-> Thread ID: 2380     Start Time: 9:05 AM      Priority: Normal
-> Thread ID: 2384     Start Time: 9:05 AM      Priority: Normal
-> Thread ID: 2308     Start Time: 9:05 AM      Priority: Normal
-> Thread ID: 3096     Start Time: 9:07 AM      Priority: Highest
-> Thread ID: 3600     Start Time: 9:45 AM      Priority: Normal
-> Thread ID: 1412     Start Time: 10:02 AM     Priority: Normal

```

The `ProcessThread` type has additional members of interest beyond `Id`, `StartTime`, and `PriorityLevel`. Table 17-4 documents some members of interest.

Table 17-4. Select Members of the `ProcessThread` Type

| Member | Meaning in Life |
|---------------------------------|---|
| <code>CurrentPriority</code> | Gets the current priority of the thread |
| <code>Id</code> | Gets the unique identifier of the thread |
| <code>IdealProcessor</code> | Sets the preferred processor for this thread to run on |
| <code>PriorityLevel</code> | Gets or sets the priority level of the thread |
| <code>ProcessorAffinity</code> | Sets the processors on which the associated thread can run |
| <code>StartAddress</code> | Gets the memory address of the function that the operating system called that started this thread |
| <code>StartTime</code> | Gets the time that the operating system started the thread |
| <code>ThreadState</code> | Gets the current state of this thread |
| <code>TotalProcessorTime</code> | Gets the total amount of time that this thread has spent using the processor |
| <code>WaitReason</code> | Gets the reason that the thread is waiting |

Before you read any further, be aware that the `ProcessThread` type is *not* the entity used to create, suspend, or kill threads under the .NET platform. Rather, `ProcessThread` is a vehicle used to obtain diagnostic information for the active Windows threads within a running process. Again, you will investigate how to build multithreaded applications using the `System.Threading` namespace in Chapter 19.

Investigating a Process's Module Set

Next up, let's check out how to iterate over the number of loaded modules that are hosted within a given process. When talking about processes, a *module* is a general term used to describe a given *.dll (or the *.exe itself) that is hosted by a specific process. When you access the `ProcessModuleCollection` via the `Process.Modules` property, you are able to enumerate over *all modules* hosted within a process: .NET-based, COM-based, or traditional C-based libraries. Ponder the following additional helper function that will enumerate the modules in a specific process based on the PID:

```
static void EnumModsForPid(int pID)
{
    Process theProc = null;
    try
    {
        theProc = Process.GetProcessById(pID);
    }
    catch(ArgumentException ex)
    {
        Console.WriteLine(ex.Message);
        return;
    }

    Console.WriteLine("Here are the loaded modules for: {0}",
        theProc.ProcessName);
    ProcessModuleCollection theMods = theProc.Modules;
    foreach(ProcessModule pm in theMods)
    {
        string info = string.Format("-> Mod Name: {0}", pm.ModuleName);
        Console.WriteLine(info);
    }
    Console.WriteLine("*****\n");
}
```

To see some possible output, let's check out the loaded modules for the process hosting the current example program (`ProcessManipulator`). To do so, run the application, identify the PID assigned to `ProcessManipulator.exe` (via the Task Manager), and pass this value to the `EnumModsForPid()` method (be sure to update your `Main()` method accordingly). Once you do, you might be surprised to see the list of *.dlls used for a simple Console Application project (`GDI32.dll`, `USER32.dll`, `ole32.dll`, and so forth). Consider the following output:

```
Here are the loaded modules for: ProcessManipulator
-> Mod Name: ProcessManipulator.exe
-> Mod Name: ntdll.dll
-> Mod Name: MSCOREEE.DLL
-> Mod Name: KERNEL32.dll
-> Mod Name: KERNELBASE.dll
-> Mod Name: ADVAPI32.dll
-> Mod Name: msvcrt.dll
-> Mod Name: sechost.dll
-> Mod Name: RPCRT4.dll
-> Mod Name: SspiCli.dll
```

```

-> Mod Name: CRYPTBASE.dll
-> Mod Name: mscoreei.dll
-> Mod Name: SHLWAPI.dll
-> Mod Name: GDI32.dll
-> Mod Name: USER32.dll
-> Mod Name: LPK.dll
-> Mod Name: USP10.dll
-> Mod Name: IMM32.DLL
-> Mod Name: MSCTF.dll
-> Mod Name: clr.dll
-> Mod Name: MSVCR100_CLR0400.dll
-> Mod Name: mscorlib.ni.dll
-> Mod Name: nlsorting.dll
-> Mod Name: ole32.dll
-> Mod Name: clrjit.dll
-> Mod Name: System.ni.dll
-> Mod Name: System.Core.ni.dll
-> Mod Name: psapi.dll
-> Mod Name: shfolder.dll
-> Mod Name: SHELL32.dll
*****

```

Starting and Stopping Processes Programmatically

The final aspects of the `System.Diagnostics.Process` class examined here are the `Start()` and `Kill()` methods. As you can gather by their names, these members provide a way to programmatically launch and terminate a process, respectively. For example, consider the following static `StartAndKillProcess()` helper method:

■ **Note** You must be running Visual Studio with Administrator rights to start new processes. If this is not the case, you will receive a runtime error.

```

static void StartAndKillProcess()
{
    Process ieProc = null;

    // Launch Internet Explorer, and go to facebook!
    try
    {
        ieProc = Process.Start("IExplore.exe", "www.facebook.com");
    }
    catch (InvalidOperationException ex)
    {
        Console.WriteLine(ex.Message);
    }
}

```

```

Console.WriteLine("--> Hit enter to kill {0}...", ieProc.ProcessName);
Console.ReadLine();

// Kill the iexplore.exe process.
try
{
    ieProc.Kill();
}
catch (InvalidOperationException ex)
{
    Console.WriteLine(ex.Message);
}
}

```

The static `Process.Start()` method has been overloaded a few times. At a minimum, you will need to specify the friendly name of the process you want to launch (such as Microsoft Internet Explorer, `iexplore.exe`). This example uses a variation of the `Start()` method that allows you to specify any additional arguments to pass into the program's entry point (i.e., the `Main()` method).

After you call the `Start()` method, you are returned a reference to the newly activated process. When you want to terminate the process, simply call the instance-level `Kill()` method. Here, you are wrapping the calls to `Start()` and `Kill()` within a `try/catch` block and handling any `InvalidOperationException` errors. This is especially important when calling the `Kill()` method, as this error will be raised if the process has already been terminated prior to calling `Kill()`.

Controlling Process Startup Using the `ProcessStartInfo` Class

The `Start()` method also allows you to pass in a `System.Diagnostics.ProcessStartInfo` type to specify additional bits of information regarding how a given process should come to life. Here is a partial definition of `ProcessStartInfo` (see the .NET Framework 4.5 SDK documentation for full details):

```

public sealed class ProcessStartInfo : object
{
    public ProcessStartInfo();
    public ProcessStartInfo(string fileName);
    public ProcessStartInfo(string fileName, string arguments);
    public string Arguments { get; set; }
    public bool CreateNoWindow { get; set; }
    public StringDictionary EnvironmentVariables { get; }
    public bool ErrorDialog { get; set; }
    public IntPtr ErrorDialogParentHandle { get; set; }
    public string FileName { get; set; }
    public bool LoadUserProfile { get; set; }
    public SecureString Password { get; set; }
    public bool RedirectStandardError { get; set; }
    public bool RedirectStandardInput { get; set; }
    public bool RedirectStandardOutput { get; set; }
    public Encoding StandardErrorEncoding { get; set; }
    public Encoding StandardOutputEncoding { get; set; }
    public bool UseShellExecute { get; set; }
    public string Verb { get; set; }
}

```

```

public string[] Verbs { get; }
public ProcessWindowStyle WindowStyle { get; set; }
public string WorkingDirectory { get; set; }
}

```

To illustrate how to fine-tune your process startup, here is a modified version of `StartAndKillProcess()`, which will load Microsoft Internet Explorer, navigate to www.facebook.com, and show the window in a maximized state:

```

static void StartAndKillProcess()
{
    Process ieProc = null;

    // Launch Internet Explorer, and go to facebook,
    // with maximized window.
    try
    {
        ProcessStartInfo startInfo = new
            ProcessStartInfo("IExplore.exe", "www.facebook.com");
        startInfo.WindowStyle = ProcessWindowStyle.Maximized;

        ieProc = Process.Start(startInfo);
    }
    catch (InvalidOperationException ex)
    {
        Console.WriteLine(ex.Message);
    }
    ...
}

```

Great! Now that you understand the role of Windows processes and how to interact with them from C# code, you are ready to investigate the concept of a .NET application domain.

■ **Source Code** The `ProcessManipulator` project is included in the Chapter 17 subdirectory.

Understanding .NET Application Domains

Under the .NET platform, executables are not hosted directly within a Windows process, as is the case in traditional unmanaged applications. Rather, a .NET executable is hosted by a logical partition within a process termed an *application domain*. As you will see, a single process may contain multiple application domains, each of which is hosting a .NET executable. This additional subdivision of a traditional Windows process offers several benefits, some of which are as follows:

- AppDomains are a key aspect of the OS-neutral nature of the .NET platform, given that this logical division abstracts away the differences in how an underlying OS represents a loaded executable.

- AppDomains are far less expensive in terms of processing power and memory than a full-blown process. Thus, the CLR is able to load and unload application domains much quicker than a formal process and can drastically improve scalability of server applications.
- AppDomains provide a deeper level of isolation for hosting a loaded application. If one AppDomain within a process fails, the remaining AppDomains remain functional.

As mentioned, a single process can host any number of AppDomains, each of which is fully and completely isolated from other AppDomains within this process (or any other process). Given this fact, be aware that an application running in one AppDomain is unable to obtain data of any kind (global variables or static fields) within another AppDomain, unless they use a distributed programming protocol (such as Windows Communication Foundation).

While a single process *may* host multiple AppDomains, this is not typically the case. At the least, an OS process will host what is termed the *default application domain*. This specific application domain is automatically created by the CLR at the time the process launches. After this point, the CLR creates additional application domains on an as-needed basis.

The System.AppDomain Class

The .NET platform allows you to programmatically monitor AppDomains, create new AppDomains (or unload them) at runtime, load assemblies into AppDomains, and perform a whole slew of additional tasks, using the AppDomain class in the System namespace of mscorlib.dll. Table 17-5 documents some useful methods of the AppDomain class (consult the .NET Framework 4.6 SDK documentation for full details).

Table 17-5. Select Methods of AppDomain

| Method | Meaning in Life |
|----------------------|---|
| CreateDomain() | This static method allows you to create a new AppDomain in the current process. |
| CreateInstance() | This creates an instance of a type in an external assembly, after loading said assembly into the calling application domain. |
| ExecuteAssembly() | This method executes an *.exe assembly within an application domain, given its file name. |
| GetAssemblies() | This method gets the set of .NET assemblies that have been loaded into this application domain (COM-based or C-based binaries are ignored). |
| GetCurrentThreadId() | This static method returns the ID of the active thread in the current application domain. |
| Load() | This method is used to dynamically load an assembly into the current application domain. |
| Unload() | This is another static method that allows you to unload a specified AppDomain within a given process. |

■ **Note** The .NET platform does not allow you to unload a specific assembly from memory. The only way to programmatically unload libraries is to tear down the hosting application domain via the `Unload()` method.

In addition, the `AppDomain` class defines a set of properties that can be useful when you want to monitor activity of a given application domain. Table 17-6 documents some core properties of interest.

Table 17-6. *Select Properties of AppDomain*

| Property | Meaning in Life |
|----------------------------------|--|
| <code>BaseDirectory</code> | This gets the directory path that the assembly resolver uses to probe for assemblies. |
| <code>CurrentDomain</code> | This static property gets the application domain for the currently executing thread. |
| <code>FriendlyName</code> | This gets the friendly name of the current application domain. |
| <code>MonitoringIsEnabled</code> | This gets or sets a value that indicates whether CPU and memory monitoring of application domains is enabled for the current process. Once monitoring is enabled for a process, it cannot be disabled. |
| <code>SetupInformation</code> | This gets the configuration details for a given application domain, represented by an <code>AppDomainSetup</code> object. |

Last but not least, the `AppDomain` class supports a set of events that correspond to various aspects of an application domain's life cycle. Table 17-7 shows some of the more useful events you can hook into.

Table 17-7. *Select Events of the AppDomain Type*

| Event | Meaning in Life |
|-----------------------------------|--|
| <code>AssemblyLoad</code> | This occurs when an assembly is loaded into memory. |
| <code>AssemblyResolve</code> | This event will fire when the assembly resolver cannot find the location of a required assembly. |
| <code>DomainUnload</code> | This occurs when an <code>AppDomain</code> is about to be unloaded from the hosting process. |
| <code>FirstChanceException</code> | This event allows you to be notified that an exception has been thrown from the application domain, before the CLR will begin looking for a fitting catch statement. |
| <code>ProcessExit</code> | This occurs on the default application domain when the default application domain's parent process exits. |
| <code>UnhandledException</code> | This occurs when an exception is not caught by an exception handler. |

Interacting with the Default Application Domain

Recall that when a .NET executable starts, the CLR will automatically place it into the default AppDomain of the hosting process. This is done automatically and transparently, and you never have to author any specific code to do so. However, it is possible for your application to gain access to this default application domain using the static `AppDomain.CurrentDomain` property. After you have this access point, you are able to hook into any events of interest or use the methods and properties of `AppDomain` to perform some runtime diagnostics.

To learn how to interact with the default application domain, begin by creating a new Console Application project named `DefaultAppDomainApp`. Now, update your program with the following logic, which will simply display some details about the default application domain, using a number of members of the `AppDomain` class:

```
class Program
{
    static void Main(string[] args)
    {
        Console.WriteLine("***** Fun with the default AppDomain *****\n");
        DisplayDADStats();
        Console.ReadLine();
    }

    private static void DisplayDADStats()
    {
        // Get access to the AppDomain for the current thread.
        AppDomain defaultAD = AppDomain.CurrentDomain;

        // Print out various stats about this domain.
        Console.WriteLine("Name of this domain: {0}", defaultAD.FriendlyName);
        Console.WriteLine("ID of domain in this process: {0}", defaultAD.Id);
        Console.WriteLine("Is this the default domain?: {0}",
            defaultAD.IsDefaultAppDomain());
        Console.WriteLine("Base directory of this domain: {0}", defaultAD.BaseDirectory);
    }
}
```

The output of this example is shown here:

```
***** Fun with the default AppDomain *****

Name of this domain: DefaultAppDomainApp.exe
ID of domain in this process: 1
Is this the default domain?: True
Base directory of this domain: E:\MyCode\DefaultAppDomainApp\bin\Debug\
```

Notice that the name of the default application domain will be identical to the name of the executable that is contained within it (`DefaultAppDomainApp.exe`, in this example). Also notice that the base directory value, which will be used to probe for externally required private assemblies, maps to the current location of the deployed executable.

Enumerating Loaded Assemblies

It is also possible to discover all the loaded .NET assemblies within a given application domain using the instance-level `GetAssemblies()` method. This method will return to you an array of `Assembly` objects, which, as you recall from the Chapter 15, is a member of the `System.Reflection` namespace (so don't forget to import this namespace into your C# code file).

To illustrate, define a new method named `ListAllAssembliesInAppDomain()` within the `Program` class. This helper method will obtain all loaded assemblies and print the friendly name and version of each.

```
static void ListAllAssembliesInAppDomain()
{
    // Get access to the AppDomain for the current thread.
    AppDomain defaultAD = AppDomain.CurrentDomain;

    // Now get all loaded assemblies in the default AppDomain.
    Assembly[] loadedAssemblies = defaultAD.GetAssemblies();
    Console.WriteLine("***** Here are the assemblies loaded in {0} *****\n",
        defaultAD.FriendlyName);
    foreach(Assembly a in loadedAssemblies)
    {
        Console.WriteLine("-> Name: {0}", a.GetName().Name);
        Console.WriteLine("-> Version: {0}\n", a.GetName().Version);
    }
}
```

Assuming you have updated your `Main()` method to call this new member, you will see that the application domain hosting your executable is currently making use of the following .NET libraries:

```
***** Here are the assemblies loaded in DefaultAppDomainApp.exe *****

-> Name: mscorlib
-> Version: 4.0.0.0

-> Name: DefaultAppDomainApp
-> Version: 1.0.0.0
```

Now understand that the list of loaded assemblies can change at any time as you author new C# code. For example, assume you have updated your `ListAllAssembliesInAppDomain()` method to make use of a LINQ query, which will order the loaded assemblies by name, as follows:

```
static void ListAllAssembliesInAppDomain()
{
    // Get access to the AppDomain for the current thread.
    AppDomain defaultAD = AppDomain.CurrentDomain;

    // Now get all loaded assemblies in the default AppDomain.
    var loadedAssemblies = from a in defaultAD.GetAssemblies()
        orderby a.GetName().Name select a;
```

```

Console.WriteLine("***** Here are the assemblies loaded in {0} *****\n",
    defaultAD.FriendlyName);
foreach (var a in loadedAssemblies)
{
    Console.WriteLine("-> Name: {0}", a.GetName().Name);
    Console.WriteLine("-> Version: {0}\n", a.GetName().Version);
}
}

```

If you were to run the program once again, you would see that `System.Core.dll` and `System.dll` have also been loaded into memory, as they are required for the LINQ to Objects API.

```
***** Here are the assemblies loaded in DefaultAppDomainApp.exe *****
```

```
-> Name: DefaultAppDomainApp
-> Version: 1.0.0.0
```

```
-> Name: mscorlib
-> Version: 4.0.0.0
```

```
-> Name: System
-> Version: 4.0.0.0
```

```
-> Name: System.Core
-> Version: 4.0.0.0
```

Receiving Assembly Load Notifications

If you want to be informed by the CLR when a new assembly has been loaded into a given application domain, you may handle the `AssemblyLoad` event. This event is typed against the `AssemblyLoadEventHandler` delegate, which can point to any method taking a `System.Object` as the first parameter and an `AssemblyLoadEventArgs` as the second.

Let's add one final method to the current `Program` class called `InitDAD()`. As the name suggests, this method will initialize the default application domain, specifically by handling the `AssemblyLoad` event via a fitting lambda expression.

```

private static void InitDAD()
{
    // This logic will print out the name of any assembly
    // loaded into the applicaion domain, after it has been
    // created.
    AppDomain defaultAD = AppDomain.CurrentDomain;
    defaultAD.AssemblyLoad += (o, s) =>
    {
        Console.WriteLine("{0} has been loaded!", s.LoadedAssembly.GetName().Name);
    };
}

```

As you would expect, when you run the modified application, you will be notified when a new assembly has been loaded. Here, you are simply printing the friendly name of the assembly, using the `LoadedAssembly` property of the incoming `AssemblyLoadedEventArgs` parameter.

■ **Source Code** The `DefaultAppDomainApp` project is included in the Chapter 17 subdirectory.

Creating New Application Domains

Recall that a single process is capable of hosting multiple application domains via the static `AppDomain.CreateDomain()` method. While creating new AppDomains on the fly is a rather infrequent task for most .NET applications, it is important to understand the basics of doing so. For example, as you will see later in this text, when you build *dynamic assemblies* (see Chapter 18), you will need to install them into a custom AppDomain. As well, several .NET security APIs require you to understand how to construct new AppDomains to isolate assemblies based on supplied security credentials.

To investigate how to create new application domains on the fly (and how to load new assemblies into these custom homes), create a new Console Application project named `CustomAppDomains`. The `AppDomain.CreateDomain()` method has been overloaded a number of times. At minimum, you will specify the friendly name of the new application domain to be constructed. Update your `Program` class with the following code. Here, you are leveraging the `ListAllAssembliesInAppDomain()` method from the previous example; however, this time you are passing in the `AppDomain` object to analyze as an incoming argument.

```
class Program
{
    static void Main(string[] args)
    {
        Console.WriteLine("***** Fun with Custom AppDomains *****\n");

        // Show all loaded assemblies in default AppDomain.
        AppDomain defaultAD = AppDomain.CurrentDomain;
        ListAllAssembliesInAppDomain(defaultAD);
        // Make a new AppDomain.
        MakeNewAppDomain();
        Console.ReadLine();
    }

    private static void MakeNewAppDomain()
    {
        // Make a new AppDomain in the current process and
        // list loaded assemblies.
        AppDomain newAD = AppDomain.CreateDomain("SecondAppDomain");
        ListAllAssembliesInAppDomain(newAD);
    }

    static void ListAllAssembliesInAppDomain(AppDomain ad)
    {
        // Now get all loaded assemblies in the default AppDomain.
        var loadedAssemblies = from a in ad.GetAssemblies()
                               orderby a.GetName().Name select a;
    }
}
```

```

    Console.WriteLine("***** Here are the assemblies loaded in {0} *****\n",
        ad.FriendlyName);
    foreach (var a in loadedAssemblies)
    {
        Console.WriteLine("-> Name: {0}", a.GetName().Name);
        Console.WriteLine("-> Version: {0}\n", a.GetName().Version);
    }
}
}
}

```

If you run the current example, you will see that the default application domain (`CustomAppDomains.exe`) has loaded `mscorlib.dll`, `System.dll`, `System.Core.dll`, and `CustomAppDomains.exe`, given the C# code base of the current project. However, the new application domain contains only `mscorlib.dll`, which, as you recall, is the one .NET assembly that is always loaded by the CLR for every application domain.

```

***** Fun with Custom AppDomains *****

***** Here are the assemblies loaded in CustomAppDomains.exe *****

-> Name: CustomAppDomains
-> Version: 1.0.0.0

-> Name: mscorlib
-> Version: 4.0.0.0

-> Name: System
-> Version: 4.0.0.0

-> Name: System.Core
-> Version: 4.0.0.0

***** Here are the assemblies loaded in SecondAppDomain *****

-> Name: mscorlib
-> Version: 4.0.0.0

```

■ **Note** If you debug this project (via F5), you will find many additional assemblies are loaded into each AppDomain, which are used by the Visual Studio debugging process. Running this project (via Ctrl+F5) will display only the assemblies directly within each AppDomain.

This might seem counterintuitive if you have a background in traditional Windows. (As you might suspect, both application domains have access to the same assembly set.) Recall, however, that an assembly loads into an *application domain*, not directly into the process itself.

Loading Assemblies into Custom Application Domains

The CLR will always load assemblies into the default application domain when required. However, if you do ever manually create new AppDomains, you can load assemblies into said AppDomain using the `AppDomain.Load()` method. Also, be aware that the `AppDomain.ExecuteAssembly()` method can be called to load an *.exe assembly and execute the `Main()` method.

Assume that you want to load `CarLibrary.dll` into your new secondary AppDomain. Provided you have copied this library to the `\bin\Debug` folder of the current application, you could update the `MakeNewAppDomain()` method as so (be sure to import the `System.IO` namespace, to gain access to the `FileNotFoundException` class):

```
private static void MakeNewAppDomain()
{
    // Make a new AppDomain in the current process.
    AppDomain newAD = AppDomain.CreateDomain("SecondAppDomain");

    try
    {
        // Now load CarLibrary.dll into this new domain.
        newAD.Load("CarLibrary");
    }
    catch (FileNotFoundException ex)
    {
        Console.WriteLine(ex.Message);
    }

    // List all assemblies.
    ListAllAssembliesInAppDomain(newAD);
}
```

This time, the output of the program would appear as so (note the presence of `CarLibrary.dll`):

```
***** Fun with Custom AppDomains *****
```

```
***** Here are the assemblies loaded in CustomAppDomains.exe *****
```

```
-> Name: CustomAppDomains
```

```
-> Version: 1.0.0.0
```

```
-> Name: mscorlib
```

```
-> Version: 4.0.0.0
```

```
-> Name: System
```

```
-> Version: 4.0.0.0
```

```
-> Name: System.Core
```

```
-> Version: 4.0.0.0
```

***** Here are the assemblies loaded in SecondAppDomain *****

```
-> Name: CarLibrary
-> Version: 2.0.0.0

-> Name: mscorlib
-> Version: 4.0.0.0
```

■ **Note** Remember, if you debug this application, you will see many additional libraries loaded into each application domain.

Programmatically Unloading AppDomains

It is important to point out that the CLR does not permit unloading individual .NET assemblies. However, using the `AppDomain.Unload()` method, you are able to selectively unload a given application domain from its hosting process. When you do so, the application domain will unload each assembly in turn.

Recall that the `AppDomain` type defines the `DomainUnload` event, which is fired when a custom application domain is unloaded from the containing process. Another event of interest is the `ProcessExit` event, which is fired when the default application domain is unloaded from the process (which obviously entails the termination of the process itself).

If you want to programmatically unload `newAD` from the hosting process and be notified when the associated application domain is torn down, you could update `MakeNewAppDomain()` with the following additional logic:

```
private static void MakeNewAppDomain()
{
    // Make a new AppDomain in the current process.
    AppDomain newAD = AppDomain.CreateDomain("SecondAppDomain");
    newAD.DomainUnload += (o, s) =>
    {
        Console.WriteLine("The second AppDomain has been unloaded!");
    };

    try
    {
        // Now load CarLibrary.dll into this new domain.
        newAD.Load("CarLibrary");
    }
    catch (FileNotFoundException ex)
    {
        Console.WriteLine(ex.Message);
    }

    // List all assemblies.
    ListAllAssembliesInAppDomain(newAD);
}
```



```
// Now tear down this AppDomain.
AppDomain.Unload(newAD);
}
```

If you want to be notified when the default application domain is unloaded, modify your `Main()` method to handle the `ProcessEvent` event of the default application domain, like so:

```
static void Main(string[] args)
{
    Console.WriteLine("***** Fun with Custom AppDomains *****\n");

    // Show all loaded assemblies in default AppDomain.
    AppDomain defaultAD = AppDomain.CurrentDomain;
    defaultAD.ProcessExit += (o, s) =>
    {
        Console.WriteLine("Default AD unloaded!");
    };

    ListAllAssembliesInAppDomain(defaultAD);

    MakeNewAppDomain();
    Console.ReadLine();
}
```

That wraps up your look at the .NET application domain. To conclude this chapter, let's look at one further level of partitioning, which is used to group objects into contextual boundaries.

■ **Source Code** The `CustomAppDomains` project is included in the [Chapter 17](#) subdirectory.

Understanding Object Context Boundaries

As you have just seen, `AppDomains` are logical partitions within a process used to host .NET assemblies. On a related note, a given application domain may be further subdivided into numerous context boundaries. In a nutshell, a .NET context provides a way for a single `AppDomain` to establish a “specific home” for a given object.

■ **Note** Friendly FYI: While understanding processes and application domains is quite important, most .NET applications will never demand that you work with object contexts. I've included this overview material just to paint a more complete picture.

Using context, the CLR is able to ensure that objects that have special runtime requirements are handled in an appropriate and consistent manner by intercepting method invocations into and out of a given context. This layer of interception allows the CLR to adjust the current method invocation to conform to the contextual settings of a given object. For example, if you define a C# class type that requires automatic thread safety (using the `[Synchronization]` attribute), the CLR will create a “synchronized context” during allocation.

Just as a process defines a default AppDomain, every application domain has a default context. This default context (sometimes referred to as *context 0*, given that it is always the first context created within an application domain) is used to group together .NET objects that have no specific or unique contextual needs. As you might expect, a vast majority of .NET objects are loaded into context 0. If the CLR determines a newly created object has special needs, a new context boundary is created within the hosting application domain. Figure 17-3 illustrates the process/AppDomain/context relationship.

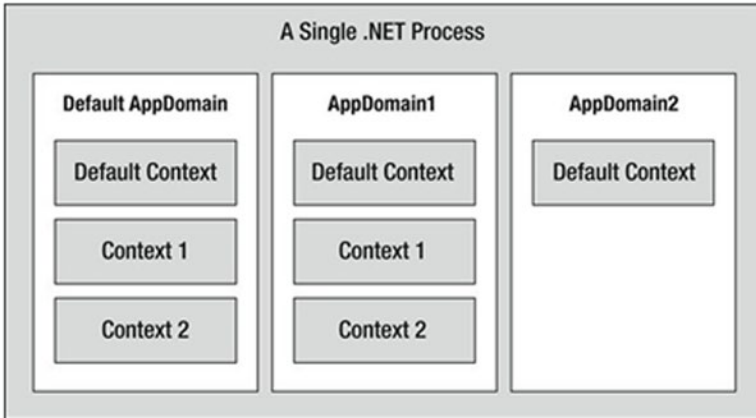

Figure 17-3. Processes, application domains, and context boundaries

Context-Agile and Context-Bound Types

.NET objects that do not demand any special contextual treatment are termed *context-agile objects*. These objects can be accessed from anywhere within the hosting AppDomain without interfering with the object's runtime requirements. Building context-agile objects is easy, given that you simply do nothing (specifically, you do not adorn the type with any contextual attributes and do not derive from the `System.ContextBoundObject` base class). Here's an example:

```
// A context-agile object is loaded into context zero.
class SportsCar{}
```

On the other hand, objects that do demand contextual allocation are termed *context-bound objects*, and they *must* derive from the `System.ContextBoundObject` base class. This base class solidifies the fact that the object in question can function appropriately only within the context in which it was created. Given the role of .NET context, it should stand to reason that if a context-bound object were to somehow end up in an incompatible context, bad things would be guaranteed to occur at the most inopportune times.

In addition to deriving from `System.ContextBoundObject`, a context-sensitive type will also be adorned by a special category of .NET attributes termed (not surprisingly) *context attributes*. All context attributes derive from the `ContextAttribute` base class. Let's see an example.

Defining a Context-Bound Object

Assume that you want to define a class (`SportsCarTS`) that is automatically thread safe in nature, even though you have not hard-coded thread synchronization logic within the member implementations. To do so, derive from `ContextBoundObject` and apply the `[Synchronization]` attribute as follows:

```
using System.Runtime.Remoting.Contexts;

// This context-bound type will only be loaded into a
// synchronized (hence thread-safe) context.
[Synchronization]
class SportsCarTS : ContextBoundObject
{}
```

Types that are attributed with the `[Synchronization]` attribute are loaded into a thread-safe context. Given the special contextual needs of the `SportsCarTS` class type, imagine the problems that would occur if an allocated object were moved from a synchronized context into a nonsynchronized context. The object is suddenly no longer thread safe and, thus, becomes a candidate for massive data corruption, as numerous threads are attempting to interact with the (now thread-volatile) reference object. To ensure the CLR does not move `SportsCarTS` objects outside a synchronized context, simply derive from `ContextBoundObject`.

Inspecting an Object's Context

Although few of the applications you will write will need to programmatically interact with context, here is an illustrative example. Create a new Console Application project named `ObjectContextApp`. This application defines one context-agile class (`SportsCar`) and a single context-bound type (`SportsCarTS`) as follows:

```
using System;
using System.Runtime.Remoting.Contexts; // For Context type.
using System.Threading; // For Thread type.

// SportsCar has no special contextual
// needs and will be loaded into the
// default context of the AppDomain.
class SportsCar
{
    public SportsCar()
    {
        // Get context information and print out context ID.
        Context ctx = Thread.CurrentContext;
        Console.WriteLine("{0} object in context {1}",
            this.ToString(), ctx.ContextID);
        foreach(IContextProperty itfCtxProp in ctx.ContextProperties)
            Console.WriteLine("-> Ctx Prop: {0}", itfCtxProp.Name);
    }
}
```

```
// SportsCarTS demands to be loaded in
// a synchronization context.
[Synchronization]
class SportsCarTS : ContextBoundObject
{
    public SportsCarTS()
    {
        // Get context information and print out context ID.
        Context ctx = Thread.CurrentContext;
        Console.WriteLine("{0} object in context {1}",
            this.ToString(), ctx.ContextID);
        foreach(IContextProperty itfCtxProp in ctx.ContextProperties)
            Console.WriteLine("-> Ctx Prop: {0}", itfCtxProp.Name);
    }
}
```

Notice that each constructor obtains a Context object from the current thread of execution, via the static `Thread.CurrentContext` property. Using the Context object, you are able to print statistics about the contextual boundary, such as its assigned ID, as well as a set of descriptors obtained via `Context.ContextProperties`. This property returns an array of objects implementing the `IContextProperty` interface, which exposes each descriptor through the `Name` property. Now, update `Main()` to allocate an instance of each class type, like so:

```
static void Main(string[] args)
{
    Console.WriteLine("***** Fun with Object Context *****\n");

    // Objects will display contextual info upon creation.
    SportsCar sport = new SportsCar();
    Console.WriteLine();

    SportsCar sport2 = new SportsCar();
    Console.WriteLine();

    SportsCarTS synchroSport = new SportsCarTS();
    Console.ReadLine();
}
```

As the objects come to life, the class constructors will dump out various bits of context-centric information (the “lease life time service property” printout is a low-level aspect of the .NET remoting layer and can be ignored).

```
***** Fun with Object Context *****

ObjectContextApp.SportsCar object in context 0
-> Ctx Prop: LeaseLifeTimeServiceProperty

ObjectContextApp.SportsCar object in context 0
-> Ctx Prop: LeaseLifeTimeServiceProperty

ObjectContextApp.SportsCarTS object in context 1
-> Ctx Prop: LeaseLifeTimeServiceProperty
-> Ctx Prop: Synchronization
```

Given that the `SportsCar` class has not been qualified with a context attribute, the CLR has allocated `sport` and `sport2` into context 0 (i.e., the default context). However, the `SportsCarTS` object is loaded into a unique contextual boundary (which has been assigned a context ID of 1), given that this context-bound type was adorned with the `[Synchronization]` attribute.

■ **Source Code** The `ObjectContextApp` project is included in the [Chapter 17](#) subdirectory.

Summarizing Processes, AppDomains, and Context

At this point, you should have a much better idea about how a .NET assembly is hosted by the CLR. These are the key points:

- A .NET process hosts one to many application domains. Each `AppDomain` is able to host any number of related .NET assemblies. `AppDomains` may be independently loaded and unloaded by the CLR (or programmatically via the `System.AppDomain` type).
- A given `AppDomain` consists of one to many contexts. Using a context, the CLR is able to place a “special needs” object into a logical container to ensure that its runtime requirements are honored.

If the previous pages have seemed to be a bit too low level for your liking, fear not. For the most part, the CLR automatically deals with the details of processes, application domains, and contexts on your behalf. The good news, however, is that this information provides a solid foundation for understanding multithreaded programming under the .NET platform.

Summary

The point of this chapter was to examine exactly how a .NET-executable image is hosted by the .NET platform. As you have seen, the long-standing notion of a Windows process has been altered under the hood to accommodate the needs of the CLR. A single process (which can be programmatically manipulated via the `System.Diagnostics.Process` type) is now composed of one or more application domains, which represent isolated and independent boundaries within a process.

As you have seen, a single process can host multiple application domains, each of which is capable of hosting and executing any number of related assemblies. Furthermore, a single application domain can contain any number of contextual boundaries. Using this additional level of type isolation, the CLR can ensure that special-need objects are handled correctly.

CHAPTER 18



Understanding CIL and the Role of Dynamic Assemblies

When you are building a full-scale .NET application, you will most certainly use C# (or a similar managed language such as Visual Basic), given its inherent productivity and ease of use. However, as you learned in the first chapter, the role of a managed compiler is to translate *.cs code files into terms of CIL code, type metadata, and an assembly manifest. As it turns out, CIL is a full-fledged .NET programming language, with its own syntax, semantics, and compiler (ilasm.exe).

In this chapter, you will be given a tour of .NET's mother tongue. Here you will understand the distinction between a CIL *directive*, CIL *attribute*, and CIL *opcode*. You will then learn about the role of round-trip engineering of a .NET assembly and various CIL programming tools. The remainder of the chapter will then walk you through the basics of defining namespaces, types, and members using the grammar of CIL. The chapter will wrap up with an examination of the role of the `System.Reflection.Emit` namespace and examine how it is possible to construct an assembly (with CIL instructions) dynamically at runtime.

Of course, few programmers will ever need to work with raw CIL code on a day-to-day basis. Therefore, I will start up this chapter by examining a few reasons why getting to know the syntax and semantics of this low-level .NET language might be worth your while.

Motivations for Learning the Grammar of CIL

CIL is the true mother tongue of the .NET platform. When you build a .NET assembly using your managed language of choice (C#, VB, F#, etc.), the associated compiler translates your source code into terms of CIL. Like any programming language, CIL provides numerous structural and implementation-centric tokens. Given that CIL is just another .NET programming language, it should come as no surprise that it is possible to build your .NET assemblies directly using CIL and the CIL compiler (ilasm.exe) that ships with the .NET Framework SDK.

Now while it is true that few (if any!) programmers would choose to build an entire .NET application directly with CIL, CIL is still an extremely interesting intellectual pursuit. Simply put, the more you understand the grammar of CIL, the better able you are to move into the realm of advanced .NET development. By way of some concrete examples, individuals who possess an understanding of CIL are capable of the following:

- Disassembling an existing .NET assembly, editing the CIL code, and recompiling the updated code base into a modified .NET binary. For example, there are some scenarios where you might need to modify CIL to interoperate with some advanced COM features.
- Building dynamic assemblies using the `System.Reflection.Emit` namespace. This API allows you to generate an in-memory .NET assembly, which can optionally be persisted to disk. This is a useful technique for the tool builders of the world who need to generate assemblies on the fly.
- Understanding aspects of the CTS that are not supported by higher-level managed languages but do exist at the level of CIL. To be sure, CIL is the only .NET language that allows you to access every aspect of the CTS. For example, using raw CIL, you are able to define global-level members and fields (which are not permissible in C#).

Again, to be perfectly clear, if you choose *not* to concern yourself with the details of CIL code, you are still absolutely able to gain mastery of C# and the .NET base class libraries. In many ways, knowledge of CIL is analogous to a C(++) programmer's understanding of assembly language. Those who know the ins and outs of the low-level "goo" are able to create rather advanced solutions for the task at hand and gain a deeper understanding of the underlying programming (and runtime) environment. So, if you are up for the challenge, let's begin to examine the details of CIL.

■ **Note** Understand that this chapter is not intended to be a comprehensive treatment of the syntax and semantics of CIL. If you require a full examination of the topic, I recommend downloading the official ECMA specification (ecma-335.pdf) from the ECMA International web site (www.ecma-international.org).

Examining CIL Directives, Attributes, and Opcodes

When you begin to investigate low-level languages such as CIL, you are guaranteed to find new (and often intimidating-sounding) names for familiar concepts. For example, at this point in the text, if you were shown the following set of items

```
{new, public, this, base, get, set, explicit, unsafe, enum, operator, partial}
```

you would most certainly understand them to be keywords of the C# language (which is correct). However, if you look more closely at the members of this set, you might be able to see that while each item is indeed a C# keyword, it has radically different semantics. For example, the `enum` keyword defines a `System.Enum`-derived type, while the `this` and `base` keywords allow you to reference the current object or the object's parent class, respectively. The `unsafe` keyword is used to establish a block of code that cannot be directly monitored by the CLR, while the `operator` keyword allows you to build a hidden (specially named) method that will be called when you apply a specific C# operator (such as the plus sign).

In stark contrast to a higher-level language such as C#, CIL does not just simply define a general set of keywords per se. Rather, the token set understood by the CIL compiler is subdivided into the following three broad categories based on semantics:

- CIL directives
- CIL attributes
- CIL operation codes (opcodes)

Each category of CIL token is expressed using a particular syntax, and the tokens are combined to build a valid .NET assembly.

The Role of CIL Directives

First up, there is a set of well-known CIL tokens that are used to describe the overall structure of a .NET assembly. These tokens are called *directives*. CIL directives are used to inform the CIL compiler how to define the namespace(s), type(s), and member(s) that will populate an assembly.

Directives are represented syntactically using a single dot (.) prefix (e.g., `.namespace`, `.class`, `.publickeytoken`, `.method`, `.assembly`, etc.). Thus, if your *.il file (the conventional extension for a file containing CIL code) has a single `.namespace` directive and three `.class` directives, the CIL compiler will generate an assembly that defines a single .NET namespace containing three .NET class types.

The Role of CIL Attributes

In many cases, CIL directives in and of themselves are not descriptive enough to fully express the definition of a given .NET type or type member. Given this fact, many CIL directives can be further specified with various CIL *attributes* to qualify how a directive should be processed. For example, the `.class` directive can be adorned with the `public` attribute (to establish the type visibility), the `extends` attribute (to explicitly specify the type's base class), and the `implements` attribute (to list the set of interfaces supported by the type).

■ **Note** Don't confuse a .NET attribute (see Chapter 15) with that of a CIL attribute, which are two very different concepts.

The Role of CIL Opcodes

Once a .NET assembly, namespace, and type set have been defined in terms of CIL using various directives and related attributes, the final remaining task is to provide the type's implementation logic. This is a job for *operation codes*, or simply *opcodes*. In the tradition of other low-level languages, many CIL opcodes tend to be cryptic and completely unpronounceable by us mere humans. For example, if you need to load a string variable into memory, you don't use a friendly opcode named `LoadString` but rather `ldstr`.

Now, to be fair, some CIL opcodes do map quite naturally to their C# counterparts (e.g., `box`, `unbox`, `throw`, and `sizeof`). As you will see, the opcodes of CIL are always used within the scope of a member's implementation, and unlike CIL directives, they are never written with a dot prefix.

The CIL Opcode/CIL Mnemonic Distinction

As just explained, opcodes such as `ldstr` are used to implement the members of a given type. In reality, however, tokens such as `ldstr` are *CIL mnemonics* for the actual *binary CIL opcodes*. To clarify the distinction, assume you have authored the following method in C#:

```
static int Add(int x, int y)
{
    return x + y;
}
```

The act of adding two numbers is expressed in terms of the CIL opcode `0X58`. In a similar vein, subtracting two numbers is expressed using the opcode `0X59`, and the act of allocating a new object on the managed heap is achieved using the `0X73` opcode. Given this reality, understand that the “CIL code” processed by a JIT compiler is actually nothing more than blobs of binary data.

Thankfully, for each binary opcode of CIL, there is a corresponding mnemonic. For example, the `add` mnemonic can be used rather than `0X58`, `sub` rather than `0X59`, and `newobj` rather than `0X73`. Given this opcode/mnemonic distinction, realize that CIL decompilers such as `ildasm.exe` translate an assembly’s binary opcodes into their corresponding CIL mnemonics. For example, here would be the CIL presented by `ildasm.exe` for the previous C# `Add()` method (your exact output may differ based on your version of .NET):

```
.method private hidebysig static int32 Add(int32 x,
    int32 y) cil managed
{
    // Code size 9 (0x9)
    .maxstack 2
    .locals init ([0] int32 CS$1$0000)
    IL_0000: nop
    IL_0001: ldarg.0
    IL_0002: ldarg.1
    IL_0003: add
    IL_0004: stloc.0
    IL_0005: br.s IL_0007
    IL_0007: ldloc.0
    IL_0008: ret
}
```

Unless you’re building some extremely low-level .NET software (such as a custom managed compiler), you’ll never need to concern yourself with the literal numeric binary opcodes of CIL. For all practical purposes, when .NET programmers speak about “CIL opcodes,” they’re referring to the set of friendly string token mnemonics (as I’ve done within this text and will do for the remainder of this chapter) rather than the underlying numerical values.

Pushing and Popping: The Stack-Based Nature of CIL

Higher-level .NET languages (such as C#) attempt to hide low-level CIL grunge from view as much as possible. One aspect of .NET development that is particularly well hidden is that CIL is a stack-based programming language. Recall from the examination of the collection namespaces (see Chapter 9) that the `Stack<T>` class can be used to push a value onto a stack as well as pop the topmost value off of the stack for use. Of course, CIL developers do not use an object of type `Stack<T>` to load and unload the values to be evaluated; however, the same pushing and popping mind-set still applies.

Formally speaking, the entity used to hold a set of values to be evaluated is termed the *virtual execution stack*. As you will see, CIL provides a number of opcodes that are used to push a value onto the stack; this process is termed *loading*. As well, CIL defines a number of additional opcodes that transfer the topmost value on the stack into memory (such as a local variable) using a process termed *storing*.

In the world of CIL, it is impossible to access a point of data directly, including locally defined variables, incoming method arguments, or field data of a type. Rather, you are required to explicitly load the item onto the stack, only to then pop it off for later use (keep this point in mind, as it will help explain why a given block of CIL code can look a bit redundant).

■ **Note** Recall that CIL is not directly executed but compiled on demand. During the compilation of CIL code, many of these implementation redundancies are optimized away. Furthermore, if you enable the code optimization option for your current project (using the Build tab of the Visual Studio Project Properties window), the compiler will also remove various CIL redundancies.

To understand how CIL leverages a stack-based processing model, consider a simple C# method, `PrintMessage()`, which takes no arguments and returns `void`. Within the implementation of this method, you will simply print the value of a local string variable to the standard output stream, like so:

```
public void PrintMessage()
{
    string myMessage = "Hello.";
    Console.WriteLine(myMessage);
}
```

If you were to examine how the C# compiler translates this method in terms of CIL, you would first find that the `PrintMessage()` method defines a storage slot for a local variable using the `.locals` directive. The local string is then loaded and stored in this local variable using the `ldstr` (load string) and `stloc.0` opcodes (which can be read as “store the current value in a local variable at storage slot zero”).

The value (again, at index 0) is then loaded into memory using the `ldloc.0` (“load the local argument at index 0”) opcode for use by the `System.Console.WriteLine()` method invocation (specified using the `call` opcode). Finally, the function returns via the `ret` opcode. Here is the (annotated) CIL code for the `PrintMessage()` method (note that I’ve removed the `nop` opcodes from this listing, for brevity):

```
.method public hidebysig instance void PrintMessage() cil managed
{
    .maxstack 1
    // Define a local string variable (at index 0).
    .locals init ([0] string myMessage)

    // Load a string onto the stack with the value "Hello."
    ldstr " Hello."

    // Store string value on the stack in the local variable.
    stloc.0

    // Load the value at index 0.
    ldloc.0
```

```
// Call method with current value.
call void [mscorlib]System.Console::WriteLine(string)
ret
}
```

■ **Note** As you can see, CIL supports code comments using the double-slash syntax (as well as the `/*...*/` syntax, for that matter). As in C#, code comments are completely ignored by the CIL compiler.

Now that you have the basics of CIL directives, attributes, and opcodes, let's see a practical use of CIL programming, beginning with the topic of round-trip engineering.

Understanding Round-Trip Engineering

You are aware of how to use `ildasm.exe` to view the CIL code generated by the C# compiler (see Chapter 1). What you might not know, however, is that `ildasm.exe` allows you to dump the CIL contained within an assembly loaded into `ildasm.exe` to an external file. Once you have the CIL code at your disposal, you are free to edit and recompile the code base using the CIL compiler, `ilasm.exe`.

Formally speaking, this technique is termed *round-trip engineering*, and it can be useful under select circumstances, such as the following:

- You need to modify an assembly for which you no longer have the source code.
- You are working with a less-than-perfect .NET language compiler that has emitted ineffective (or flat-out incorrect) CIL code, and you want to modify the code base.
- You are constructing a COM interoperability library and want to account for some COM IDL attributes that have been lost during the conversion process (such as the COM `[helpstring]` attribute).

To illustrate the process of round-tripping, begin by creating a new C# code file (`HelloProgram.cs`) using a simple text editor such as Notepad, and define the following class type (you are free to create a new Console Application project using Visual Studio if you want. However, be sure to delete the `AssemblyInfo.cs` file to decrease the amount of generated CIL code).

```
// A simple C# console app.
using System;

// Note that we are not wrapping our class in a namespace,
// to help simplify the generated CIL code.
class Program
{
    static void Main(string[] args)
    {
        Console.WriteLine("Hello CIL code!");
        Console.ReadLine();
    }
}
```

Save your file to a convenient location (for example, C:\RoundTrip) and compile your program using `csc.exe`, like so:

```
csc HelloProgram.cs
```

Now, open `HelloProgram.exe` with `ildasm.exe` and, using the File ► Dump menu option, save the raw CIL code to a new `*.il` file (`HelloProgram.il`) in the same folder containing your compiled assembly (all the default values of the resulting dialog box are fine as is).

■ **Note** `ildasm.exe` will also generate a `*.res` file when dumping the contents of an assembly to file. These resource files can be ignored (and deleted) throughout this chapter, as you will not be using them. This file contains some low-level CLR security information (among other things).

Now you are able to view `HelloProgram.il` using your text editor of choice. Here is the (slightly reformatted and annotated) result:

// Referenced assemblies.

```
.assembly extern mscorlib
{
    .publickeytoken = (B7 7A 5C 56 19 34 E0 89 )
    .ver 4:0:0:0
}
```

// Our assembly.

```
.assembly HelloProgram
{
    /**** TargetFrameworkAttribute data removed for clarity! ****/

    .hash algorithm 0x00008004
    .ver 0:0:0:0
}
.module HelloProgram.exe
.imagebase 0x00400000
.file alignment 0x00000200
.stackreserve 0x00100000
.subsystem 0x0003
.corflags 0x00000003
```

// Definition of Program class.

```
.class private auto ansi beforefieldinit Program
    extends [mscorlib]System.Object
{
    .method private hidebysig static void Main(string[] args) cil managed
    {
        // Marks this method as the entry point of the
        // executable.
        .entrypoint
        .maxstack 8
        IL_0000: nop
    }
}
```

```

    IL_0001: ldstr "Hello CIL code!"
    IL_0006: call void [mscorlib]System.Console::WriteLine(string)
    IL_000b: nop
    IL_000c: call string [mscorlib]System.Console::ReadLine()
    IL_0011: pop
    IL_0012: ret
}

// The default constructor.
.method public hidebysig specialname
    instance void .ctor() cil managed
{
    .maxstack 8
    IL_0000: ldarg.0
    IL_0001: call instance void [mscorlib]System.Object::.ctor()
    IL_0006: ret
}
}

```

First, notice that the *.il file opens by declaring each externally referenced assembly the current assembly is compiled against. Here, you can see a single `.assembly extern` token set for the always present `mscorlib.dll`. Of course, if your class library used types within other referenced assemblies, you would find additional `.assembly extern` directives.

Next, you find the formal definition of your `HelloProgram.exe` assembly, which has been assigned a default version of `0.0.0.0` (given that you did not specify a value using the `[AssemblyVersion]` attribute). The assembly is further described using various CIL directives (such as `.module`, `.imagebase`, and so forth).

After documenting the externally referenced assemblies and defining the current assembly, you find a definition of the `Program` type. Note that the `.class` directive has various attributes (many of which are actually optional) such as `extends`, shown here, which marks the base class of the type:

```

.class private auto ansi beforefieldinit Program
    extends [mscorlib]System.Object
{ ... }

```

The bulk of the CIL code represents the implementation of the class's default constructor and the `Main()` method, both of which are defined (in part) with the `.method` directive. Once the members have been defined using the correct directives and attributes, they are implemented using various opcodes.

It is critical to understand that when interacting with .NET types (such as `System.Console`) in CIL, you will *always* need to use the type's fully qualified name. Furthermore, the type's fully qualified name must *always* be prefixed with the friendly name of the defining assembly (in square brackets). Consider the following CIL implementation of `Main()`:

```

.method private hidebysig static void Main(string[] args) cil managed
{
    .entrypoint
    .maxstack 8
    IL_0000: nop
    IL_0001: ldstr "Hello CIL code!"
    IL_0006: call void [mscorlib]System.Console::WriteLine(string)
    IL_000b: nop
}

```

```

IL_000c: call string [mscorlib]System.Console::ReadLine()
IL_0011: pop
IL_0012: ret
}

```

The implementation of the default constructor in terms of CIL code makes use of yet another “load-centric” instruction (`ldarg.0`). In this case, the value loaded onto the stack is not a custom variable specified by you but the current object reference (more details on this later). Also note that the default constructor explicitly makes a call to the base class constructor, as follows (which, in this case, is your good friend `System.Object`):

```

.method public hidebysig specialname rtspecialname
  instance void .ctor() cil managed
{
  .maxstack 8
  IL_0000: ldarg.0
  IL_0001: call instance void [mscorlib]System.Object::.ctor()
  IL_0006: ret
}

```

The Role of CIL Code Labels

One thing you certainly have noticed is that each line of implementation code is prefixed with a token of the form `IL_XXX:` (e.g., `IL_0000:`, `IL_0001:`, and so on). These tokens are called *code labels* and may be named in any manner you choose (provided they are not duplicated within the same member scope). When you dump an assembly to file using `ildasm.exe`, it will automatically generate code labels that follow an `IL_XXX:` naming convention. However, you may change them to reflect a more descriptive marker. Here’s an example:

```

.method private hidebysig static void Main(string[] args) cil managed
{
  .entrypoint
  .maxstack 8
  Nothing_1: nop
  Load_String: ldstr "Hello CIL code!"
  PrintToConsole: call void [mscorlib]System.Console::WriteLine(string)
  Nothing_2: nop
  WaitFor_KeyPress: call string [mscorlib]System.Console::ReadLine()
  RemoveValueFromStack: pop
  Leave_Function: ret
}

```

The truth of the matter is that most code labels are completely optional. The only time code labels are truly mandatory is when you are authoring CIL code that makes use of various branching or looping constructs, as you can specify where to direct the flow of logic via these code labels. For the current example, you can remove these autogenerated labels altogether with no ill effect, like so:

```

.method private hidebysig static void Main(string[] args) cil managed
{
  .entrypoint
  .maxstack 8

```

```

nop
ldstr "Hello CIL code!"
call void [mscorlib]System.Console::WriteLine(string)
nop
call string [mscorlib]System.Console::ReadLine()
pop
ret
}

```

Interacting with CIL: Modifying an *.il File

Now that you have a better understanding of how a basic CIL file is composed, let's complete the round-tripping experiment. The goal here is to update the CIL within the existing *.il file as follows:

1. Add a reference to the `System.Windows.Forms.dll` assembly.
2. Load a local string within `Main()`.
3. Call the `System.Windows.Forms.MessageBox.Show()` method using the local string variable as an argument.

The first step is to add a new `.assembly` directive (qualified with the `extern` attribute) that specifies your assembly requires the `System.Windows.Forms.dll` assembly. To do so, update the *.il file with the following logic after the external reference to `mscorlib`:

```

.assembly extern System.Windows.Forms
{
    .publickeytoken = (B7 7A 5C 56 19 34 E0 89)
    .ver 4:0:0:0
}

```

Be aware that the value assigned to the `.ver` directive may differ depending on which version of the .NET platform you have installed on your development machine. Here, you see that `System.Windows.Forms.dll` version 4.0.0.0 is used and has the public key token of `B77A5C561934E089`. If you open the GAC (see Chapter 14) and locate your version of the `System.Windows.Forms.dll` assembly, you can simply copy the correct version and public key token value.

Next, you need to alter the current implementation of the `Main()` method. Locate this method within the *.il file and remove the current implementation code (the `.maxstack` and `.entrypoint` directives should remain intact), like so:

```

.method private hidebysig static void Main(string[] args) cil managed
{
    .entrypoint
    .maxstack 8
    // ToDo: Write new CIL code!
}

```

Again, the goal here is to push a new string onto the stack and call the `MessageBox.Show()` method (rather than the `Console.WriteLine()` method). Recall that when you specify the name of an external type, you must use the type's fully qualified name (in conjunction with the friendly name of the assembly). Also notice that in terms of CIL, every method call documents the fully qualified return type. Keeping these things in mind, update the `Main()` method as follows:

```
.method private hidebysig static void Main(string[] args) cil managed
{
    .entrypoint
    .maxstack 8

    ldstr "CIL is way cool"
    call valuetype [System.Windows.Forms]
        System.Windows.Forms.DialogResult
        [System.Windows.Forms]
        System.Windows.Forms.MessageBox::Show(string)
    pop
    ret
}
```

In effect, you have just updated the CIL code to correspond to the following C# class definition:

```
class Program
{
    static void Main(string[] args)
    {
        System.Windows.Forms.MessageBox.Show("CIL is way cool");
    }
}
```

Compiling CIL Code Using `ilasm.exe`

Assuming you have saved this modified `*.il` file, you can compile a new .NET assembly using the `ilasm.exe` (CIL compiler) utility. While the CIL compiler has numerous command-line options (all of which can be seen by specifying the `-?` option), Table 18-1 shows the core flags of interest.

Table 18-1. Common `ilasm.exe` Command-Line Flags

| Flag | Meaning in Life |
|----------------------|---|
| <code>/debug</code> | Includes debug information (such as local variable and argument names, as well as line numbers). |
| <code>/dll</code> | Produces a <code>*.dll</code> file as output. |
| <code>/exe</code> | Produces an <code>*.exe</code> file as output. This is the default setting and may be omitted. |
| <code>/key</code> | Compiles the assembly with a strong name using a given <code>*.snk</code> file. |
| <code>/output</code> | Specifies the output file name and extension. If you do not use the <code>/output</code> flag, the resulting file name (minus the file extension) is the same as the name of the first source file. |

To compile your updated `HelloProgram.il` file into a new `.NET *.exe`, you can issue the following command within a Developer Command prompt:

```
ilasm /exe HelloProgram.il /output=NewAssembly.exe
```

Assuming things have worked successfully, you will see the report shown here:

```
Microsoft (R) .NET Framework IL Assembler. Version 4.0.30319.33440
Copyright (c) Microsoft Corporation. All rights reserved.
Assembling 'HelloProgram.il' to EXE --> 'NewAssembly.exe'
Source file is UTF-8

Assembled method Program::Main
Assembled method Program::.ctor
Creating PE file

Emitting classes:
Class 1: Program

Emitting fields and methods:
Global
Class 1 Methods: 2;

Emitting events and properties:
Global
Class 1
Writing PE file
Operation completed successfully
```

At this point, you can run your new application. Sure enough, rather than showing a message within the console window, you will now see a message box displaying your message. While the output of this simple example is not all that spectacular, it does illustrate one practical use of programming in CIL round-tripping.

The Role of `peverify.exe`

When you are building or modifying assemblies using CIL code, it is always advisable to verify that the compiled binary image is a well-formed `.NET` image using the `peverify.exe` command-line tool, like so:

```
peverify NewAssembly.exe
```

This tool will examine all opcodes within the specified assembly for valid CIL code. For example, in terms of CIL code, the evaluation stack must always be empty before exiting a function. If you forget to pop off any remaining values, the `ilasm.exe` compiler will still generate a compiled assembly (given that compilers are concerned only with *syntax*). `peverify.exe`, on the other hand, is concerned with *semantics*. If you did forget to clear the stack before exiting a given function, `peverify.exe` will let you know before you try running your code base.

■ **Source Code** The RoundTrip example is included in the Chapter 18 subdirectory.

Understanding CIL Directives and Attributes

Now that you have seen how `ildasm.exe` and `ilasm.exe` can be used to perform a round-trip, you can get down to the business of checking out the syntax and semantics of CIL itself. The next sections will walk you through the process of authoring a custom namespace containing a set of types. However, to keep things simple, these types will not contain any implementation logic for their members (yet). After you understand how to create empty types, you can then turn your attention to the process of defining “real” members using CIL opcodes.

Specifying Externally Referenced Assemblies in CIL

Create a new file named `CILTypes.il` using your editor of choice. The first task a CIL project will require is to list the set of external assemblies used by the current assembly. For this example, you will only use types found within `mscorlib.dll`. To do so, the `.assembly` directive will be qualified using the external attribute. When you are referencing a strongly named assembly, such as `mscorlib.dll`, you’ll want to specify the `.publickeytoken` and `.ver` directives as well, like so:

```
.assembly extern mscorlib
{
  .publickeytoken = (B7 7A 5C 56 19 34 E0 89 )
  .ver 4:0:0:0
}
```

■ **Note** Strictly speaking, you are not required to explicitly reference `mscorlib.dll` as an external reference, as `ilasm.exe` will do so automatically. However, for each external .NET library your CIL project requires, you will need to author a similar `.assembly extern` directive.

Defining the Current Assembly in CIL

The next order of business is to define the assembly you are interested in building using the `.assembly` directive. At the simplest level, an assembly can be defined by specifying the friendly name of the binary, like so:

```
// Our assembly.
.assembly CILTypes { }
```

While this indeed defines a new .NET assembly, you will typically place additional directives within the scope of the assembly declaration. For this example, update your assembly definition to include a version number of 1.0.0.0 using the `.ver` directive (note that each numerical identifier is separated by *colons*, not the C#-centric dot notation), as follows:

```
// Our assembly.
.assembly CILTypes
{
  .ver 1:0:0:0
}
```

Given that the `CILTypes` assembly is a single-file assembly (see Chapter 14), you will finish up the assembly definition using the following single `.module` directive, which marks the official name of your .NET binary, `CILTypes.dll`:

```
.assembly CILTypes
{
  .ver 1:0:0:0
}
// The module of our single-file assembly.
.module CILTypes.dll
```

In addition to `.assembly` and `.module` are CIL directives that further qualify the overall structure of the .NET binary you are composing. Table 18-2 lists a few of the more common assembly-level directives.

Table 18-2. *Additional Assembly-Centric Directives*

| Directive | Meaning in Life |
|--------------------------|--|
| <code>.mresources</code> | If your assembly uses internal resources (such as bitmaps or string tables), this directive is used to identify the name of the file that contains the resources to be embedded. |
| <code>.subsystem</code> | This CIL directive is used to establish the preferred UI that the assembly want to execute within. For example, a value of 2 signifies that the assembly should run within a GUI application, whereas a value of 3 denotes a console executable. |

Defining Namespaces in CIL

Now that you have defined the look and feel of your assembly (and the required external references), you can create a .NET namespace (`MyNamespace`) using the `.namespace` directive, like so:

```
// Our assembly has a single namespace.
.namespace MyNamespace {}
```

Like C#, CIL namespace definitions can be nested within further namespaces. There is no need to define a root namespace here; however, for the sake of argument, assume you want to create the following root namespace named `MyCompany`:

```
.namespace MyCompany
{
  .namespace MyNamespace {}
}
```

Like C#, CIL allows you to define a nested namespace as follows:

```
// Defining a nested namespace.
.namespace MyCompany.MyNamespace {}
```

Defining Class Types in CIL

Empty namespaces are not very interesting, so let's now check out the process of defining a class type using CIL. Not surprisingly, the `.class` directive is used to define a new class. However, this simple directive can be adorned with numerous additional attributes, to further qualify the nature of the type. To illustrate, add a public class to your namespace named `MyBaseClass`. As in C#, if you do not specify an explicit base class, your type will automatically be derived from `System.Object`.

```
.namespace MyNamespace
{
  // System.Object base class assumed.
  .class public MyBaseClass {}
}
```

When you are building a class type that derives from any class other than `System.Object`, you use the `extends` attribute. Whenever you need to reference a type defined within the same assembly, CIL demands that you also use the fully qualified name (however, if the base type is within the same assembly, you can omit the assembly's friendly name prefix). Therefore, the following attempt to extend `MyBaseClass` results in a compiler error:

```
// This will not compile!
.namespace MyNamespace
{
  .class public MyBaseClass {}

  .class public MyDerivedClass
    extends MyBaseClass {}
}
```

To correctly define the parent class of `MyDerivedClass`, you must specify the full name of `MyBaseClass` as follows:

```
// Better!
.namespace MyNamespace
{
  .class public MyBaseClass {}

  .class public MyDerivedClass
    extends MyNamespace.MyBaseClass {}
}
```

In addition to the `public` and `extends` attributes, a CIL class definition may take numerous additional qualifiers that control the type's visibility, field layout, and so on. Table 18-3 illustrates some (but not all) of the attributes that may be used in conjunction with the `.class` directive.

Table 18-3. Various Attributes Used in Conjunction with the `.class` Directive

| Attributes | Meaning in Life |
|---|--|
| public, private, nested assembly, nested famandassem, nested family, nested famorassem, nested public, nested private | CIL defines various attributes that are used to specify the visibility of a given type. As you can see, raw CIL offers numerous possibilities other than those offered by C#. Refer to ECMA 335 for details if you are interested. |
| abstract, sealed | These two attributes may be tacked onto a <code>.class</code> directive to define an abstract class or sealed class, respectively. |
| auto, sequential, explicit | These attributes are used to instruct the CLR how to lay out field data in memory. For class types, the default layout flag (<code>auto</code>) is appropriate. Changing this default can be helpful if you need to use <code>P/Invoke</code> to call into unmanaged C code. |
| extends, implements | These attributes allow you to define the base class of a type (via <code>extends</code>) or implement an interface on a type (via <code>implements</code>). |

Defining and Implementing Interfaces in CIL

As odd as it might seem, interface types are defined in CIL using the `.class` directive. However, when the `.class` directive is adorned with the `interface` attribute, the type is realized as a CTS interface type. Once an interface has been defined, it may be bound to a class or structure type using the CIL `implements` attribute, like so:

```
.namespace MyNamespace
{
    // An interface definition.
    .class public interface IMyInterface {}

    // A simple base class.
    .class public MyBaseClass {}

    // MyDerivedClass now implements IMyInterface,
    // and extends MyBaseClass.
    .class public MyDerivedClass
        extends MyNamespace.MyBaseClass
        implements MyNamespace.IMyInterface {}
}
```

■ **Note** The `extends` clause must precede the `implements` clause. As well, the `implements` clause can incorporate a comma-separated list of interfaces.

As you recall from Chapter 9, interfaces can function as the base interface to other interface types in order to build interface hierarchies. However, contrary to what you might be thinking, the `extends` attribute cannot be used to derive interface A from interface B. The `extends` attribute is used only to qualify a type's base class. When you want to extend an interface, you will use the `implements` attribute yet again. Here's an example:

// Extending interfaces in terms of CIL.

```
.class public interface IMyInterface {}

.class public interface IMyOtherInterface
    implements MyNamespace.IMyInterface {}
```

Defining Structures in CIL

The `.class` directive can be used to define a CTS structure if the type extends `System.ValueType`. As well, the `.class` directive must be qualified with the `sealed` attribute (given that structures can never be a base structure to other value types). If you attempt to do otherwise, `ilasm.exe` will issue a compiler error.

// A structure definition is always sealed.

```
.class public sealed MyStruct
    extends [mscorlib]System.ValueType{}
```

Do be aware that CIL provides a shorthand notation to define a structure type. If you use the `value` attribute, the new type will derive the type from `[mscorlib]System.ValueType` automatically. Therefore, you could define `MyStruct` as follows:

// Shorthand notation for declaring a structure.

```
.class public sealed value MyStruct{}
```

Defining Enums in CIL

.NET enumerations (as you recall) derive from `System.Enum`, which is a `System.ValueType` (and therefore must also be sealed). When you want to define an enum in terms of CIL, simply extend `[mscorlib]System.Enum`, like so:

// An enum.

```
.class public sealed MyEnum
    extends [mscorlib]System.Enum{}
```

Like a structure definition, enumerations can be defined with a shorthand notation using the `enum` attribute. Here's an example:

// Enum shorthand.

```
.class public sealed enum MyEnum{}
```

You'll see how to specify the name-value pairs of an enumeration in just a moment.

■ **Note** The other fundamental .NET type, the delegate, also has a specific CIL representation. See Chapter 10 for details.

Defining Generics in CIL

Generic types also have a specific representation in the syntax of CIL. Recall from Chapter 9 that a given generic type or generic member may have one or more type parameters. For example, the `List<T>` type has a single type parameter, while `Dictionary<TKey, TValue>` has two. In terms of CIL, the number of type parameters is specified using a backward-leaning single tick (```), followed by a numerical value representing the number of type parameters. Like C#, the actual value of the type parameters is encased within angled brackets.

■ **Note** On most keyboards, you can find the ``` character on the key above the Tab key (and to the left of the 1 key).

For example, assume you want to create a `List<T>` variable, where `T` is of type `System.Int32`. In C#, you would type the following:

```
void SomeMethod()
{
    List<int> myInts = new List<int>();
}
```

In CIL, you would author the following (which could appear in any CIL method scope):

```
// In C#: List<int> myInts = new List<int>();
newobj instance void class [mscorlib]
    System.Collections.Generic.List`1<int32>::.ctor()
```

Notice that this generic class is defined as `List`1<int32>`, as `List<T>` has a single type parameter. However, if you needed to define a `Dictionary<string, int>` type, you would do so as follows:

```
// In C#: Dictionary<string, int> d = new Dictionary<string, int>();
newobj instance void class [mscorlib]
    System.Collections.Generic.Dictionary`2<string,int32>::.ctor()
```

As another example, if you have a generic type that uses another generic type as a type parameter, you would author CIL code such as the following:

```
// In C#: List<List<int>> myInts = new List<List<int>>();
newobj instance void class [mscorlib]
    System.Collections.Generic.List`1<class
    [mscorlib]System.Collections.Generic.List`1<int32>>::.ctor()
```

Compiling the CILTypes.il file

Even though you have not yet added any members or implementation code to the types you have defined, you are able to compile this `*.il` file into a .NET DLL assembly (which you must do, as you have not specified a `Main()` method). Open a command prompt and enter the following command to `ilasm.exe`:

```
ilasm /dll CilTypes.il
```

After you have done so, can now open your compiled assembly into `ildasm.exe` to verify the creation of each type. After you have confirmed the contents of your assembly, run `peverify.exe` against it, like so:

```
peverify CilTypes.dll
```

Notice that you are issued errors, given that all your types are completely empty. Here is some partial output:

```
Microsoft (R) .NET Framework PE Verifier. Version 4.0.30319.33440
Copyright (c) Microsoft Corporation. All rights reserved.

[MD]: Error: Value class has neither fields nor size parameter. [token:0x02000005]
[MD]: Error: Enum has no instance field. [token:0x02000006]
...
```

To understand how to populate a type with content, you first need to examine the fundamental data types of CIL.

.NET Base Class Library, C#, and CIL Data Type Mappings

Table 18-4 illustrates how a .NET base class type maps to the corresponding C# keyword and how each C# keyword maps into raw CIL. As well, Table 18-4 documents the shorthand constant notations used for each CIL type. As you will see in just a moment, these constants are often referenced by numerous CIL opcodes.

Table 18-4. Mapping .NET Base Class Types to C# Keywords, and C# Keywords to CIL

| .NET Base Class Type | C# Keyword | CIL Representation | CIL Constant Notation |
|----------------------|------------|--------------------|-----------------------|
| System.SByte | sbyte | int8 | I1 |
| System.Byte | byte | unsigned int8 | U1 |
| System.Int16 | short | int16 | I2 |
| System.UInt16 | ushort | unsigned int16 | U2 |
| System.Int32 | int | int32 | I4 |
| System.UInt32 | uint | unsigned int32 | U4 |
| System.Int64 | long | int64 | I8 |
| System.UInt64 | ulong | unsigned int64 | U8 |
| System.Char | char | char | CHAR |
| System.Single | float | float32 | R4 |
| System.Double | double | float64 | R8 |
| System.Boolean | bool | bool | BOOLEAN |
| System.String | string | string | N/A |
| System.Object | object | object | N/A |
| System.Void | void | void | VOID |

■ **Note** The `System.IntPtr` and `System.UIntPtr` types map to native `int` and native unsigned `int` (this is good to know, as many of COM interoperability and `P/Invoke` scenarios use these extensively).

Defining Type Members in CIL

As you are already aware, .NET types may support various members. Enumerations have some set of name-value pairs. Structures and classes may have constructors, fields, methods, properties, static members, and so on. Over the course of this book's first 17 chapters, you have already seen partial CIL definitions for the items previously mentioned, but nevertheless, here is a quick recap of how various members map to CIL primitives.

Defining Field Data in CIL

Enumerations, structures, and classes can all support field data. In each case, the `.field` directive will be used. For example, let's breathe some life into the skeleton `MyEnum` enumeration and define the following three name-value pairs (note the values are specified within parentheses):

```
.class public sealed enum MyEnum
{
    .field public static literal valuetype
        MyNamespace.MyEnum A = int32(0)
    .field public static literal valuetype
        MyNamespace.MyEnum B = int32(1)
    .field public static literal valuetype
        MyNamespace.MyEnum C = int32(2)
}
```

Fields that reside within the scope of a .NET `System.Enum`-derived type are qualified using the `static` and `literal` attributes. As you would guess, these attributes set up the field data to be a fixed value accessible from the type itself (e.g., `MyEnum.A`).

■ **Note** The values assigned to an enum value may also be in hexadecimal with a `0x` prefix.

Of course, when you want to define a point of field data within a class or structure, you are not limited to a point of public static literal data. For example, you could update `MyBaseClass` to support two points of private, instance-level field data, set to default values:

```
.class public MyBaseClass
{
    .field private string stringField = "hello!"
    .field private int32 intField = int32(42)
}
```

As in C#, class field data will automatically be initialized to an appropriate default value. If you want to allow the object user to supply custom values at the time of creation for each of these points of private field data, you (of course) need to create custom constructors.

Defining Type Constructors in CIL

The CTS supports both instance-level and class-level (static) constructors. In terms of CIL, instance-level constructors are represented using the `.ctor` token, while a static-level constructor is expressed via `.cctor` (class constructor). Both of these CIL tokens must be qualified using the `rtspecialname` (return type special name) and `specialname` attributes. Simply put, these attributes are used to identify a specific CIL token that can be treated in unique ways by a given .NET language. For example, in C#, constructors do not define a return type; however, in terms of CIL, the return value of a constructor is indeed `void`.

```
.class public MyBaseClass
{
    .field private string stringField
    .field private int32 intField

    .method public hidebysig specialname rtspecialname
        instance void .ctor(string s, int32 i) cil managed
    {
        // TODO: Add implementation code...
    }
}
```

Note that the `.ctor` directive has been qualified with the `instance` attribute (as it is not a static constructor). The `cil managed` attributes denote that the scope of this method contains CIL code, rather than unmanaged code, which may be used during platform invocation requests.

Defining Properties in CIL

Properties and methods also have specific CIL representations. By way of an example, if `MyBaseClass` were updated to support a public property named `TheString`, you would author the following CIL (note again the use of the `specialname` attribute):

```
.class public MyBaseClass
{
    ...
    .method public hidebysig specialname
        instance string get_TheString() cil managed
    {
        // TODO: Add implementation code...
    }

    .method public hidebysig specialname
        instance void set_TheString(string 'value') cil managed
    {
        // TODO: Add implementation code...
    }

    .property instance string TheString()
    {
        .get instance string
            MyNamespace.MyBaseClass::get_TheString()
    }
}
```

```

    .set instance void
      MyNamespace.MyBaseClass::set_TheString(string)
  }
}

```

In terms of CIL, a property maps to a pair of methods that take `get_` and `set_` prefixes. The `.property` directive makes use of the related `.get` and `.set` directives to map property syntax to the correct “specially named” methods.

■ **Note** Notice that the incoming parameter to the `set` method of a property is placed in single quotation marks, which represents the name of the token to use on the right side of the assignment operator within the method scope.

Defining Member Parameters

In a nutshell, specifying arguments in CIL is (more or less) identical to doing so in C#. For example, each argument is defined by specifying its data type, followed by the parameter name. Furthermore, like C#, CIL provides a way to define input, output, and pass-by-reference parameters. As well, CIL allows you to define a parameter array argument (aka the C# `params` keyword), as well as optional parameters.

To illustrate the process of defining parameters in raw CIL, assume you want to build a method that takes an `int32` (by value), an `int32` (by reference), a `[mscorlib]System.Collections.ArrayList`, and a single output parameter (of type `int32`). In terms of C#, this method would look something like the following:

```

public static void MyMethod(int inputInt,
    ref int refInt, ArrayList ar, out int outputInt)
{
    outputInt = 0; // Just to satisfy the C# compiler...
}

```

If you were to map this method into CIL terms, you would find that C# reference parameters are marked with an ampersand (&) suffixed to the parameter’s underlying data type (`int32&`).

Output parameters also use the & suffix, but they are further qualified using the CIL `[out]` token. Also notice that if the parameter is a reference type (in this case, the `[mscorlib]System.Collections.ArrayList` type), the class token is prefixed to the data type (not to be confused with the `.class` directive!).

```

.method public hidebysig static void MyMethod(int32 inputInt,
    int32& refInt,
    class [mscorlib]System.Collections.ArrayList ar,
    [out] int32& outputInt) cil managed
{
    ...
}

```

Examining CIL Opcodes

The final aspect of CIL code you'll examine in this chapter has to do with the role of various operational codes (opcodes). Recall that an opcode is simply a CIL token used to build the implementation logic for a given member. The complete set of CIL opcodes (which is fairly large) can be grouped into the following broad categories:

- Opcodes that control program flow
- Opcodes that evaluate expressions
- Opcodes that access values in memory (via parameters, local variables, etc.)

To provide some insight to the world of member implementation via CIL, Table 18-5 defines some of the more useful opcodes that are directly related to member implementation logic, grouped by related functionality.

Table 18-5. *Various Implementation-Specific CIL Opcodes*

| Opcodes | Meaning in Life |
|----------------------------|--|
| add, sub, mul, div, rem | These CIL opcodes allow you to add, subtract, multiply, and divide two values (rem returns the remainder of a division operation). |
| and, or, not, xor | These CIL opcodes allow you to perform bit-wise operations on two values. |
| ceq, cgt, clt | These CIL opcodes allow you to compare two values on the stack in various manners. Here's an example: ceq: Compare for equality cgt: Compare for greater than clt: Compare for less than |
| box, unbox | These CIL opcodes are used to convert between reference types and value types. |
| ret | This CIL opcode is used to exit a method and return a value to the caller (if necessary). |
| beq, bgt, ble, blt, switch | These CIL opcodes (in addition to many other related opcodes) are used to control branching logic within a method. Here's an example: beq: Break to code label if equal bgt: Break to code label if greater than ble: Break to code label if less than or equal to blt: Break to code label if less than All the branch-centric opcodes require that you specify a CIL code label to jump to if the result of the test is true. |
| call | This CIL opcode is used to call a member on a given type. |
| newarr, newobj | These CIL opcodes allow you to allocate a new array or new object type into memory (respectively). |

The next broad category of CIL opcodes (a subset of which is shown in Table 18-6) is used to load (push) arguments onto the virtual execution stack. Note how these load-specific opcodes take an `ld` (load) prefix.

Table 18-6. *The Primary Stack-Centric Opcodes of CIL*

| Opcode | Meaning in Life |
|---|---|
| <code>ldarg</code> (with numerous variations) | <p>Loads a method's argument onto the stack. In addition to the general <code>ldarg</code> (which works in conjunction with a given index that identifies the argument), there are numerous other variations.</p> <p>For example, <code>ldarg</code> opcodes that have a numerical suffix (<code>ldarg_0</code>) hard-code which argument to load. As well, variations of the <code>ldarg</code> opcode allow you to hard-code the data type using the CIL constant notation shown in Table 18-4 (<code>ldarg_I4</code>, for an <code>int32</code>), as well as the data type and value (<code>ldarg_I4_5</code>, to load an <code>int32</code> with the value of 5).</p> |
| <code>ldc</code> (with numerous variations) | Loads a constant value onto the stack. |
| <code>ldfld</code> (with numerous variations) | Loads the value of an instance-level field onto the stack. |
| <code>ldloc</code> (with numerous variations) | Loads the value of a local variable onto the stack. |
| <code>ldobj</code> | Obtains all the values gathered by a heap-based object and places them on the stack. |
| <code>ldstr</code> | Loads a string value onto the stack. |

In addition to the set of load-specific opcodes, CIL provides numerous opcodes that *explicitly* pop the topmost value off the stack. As shown over the first few examples in this chapter, popping a value off the stack typically involves storing the value into temporary local storage for further use (such as a parameter for an upcoming method invocation). Given this, note how many opcodes that pop the current value off the virtual execution stack take an `st` (store) prefix. Table 18-7 hits the highlights.

Table 18-7. *Various Pop-Centric Opcodes*

| Opcode | Meaning in Life |
|---|---|
| <code>pop</code> | Removes the value currently on top of the evaluation stack but does not bother to store the value |
| <code>starg</code> | Stores the value on top of the stack into the method argument at a specified index |
| <code>stloc</code> (with numerous variations) | Pops the current value from the top of the evaluation stack and stores it in a local variable list at a specified index |
| <code>stobj</code> | Copies a value of a specified type from the evaluation stack into a supplied memory address |
| <code>stsfld</code> | Replaces the value of a static field with a value from the evaluation stack |

Do be aware that various CIL opcodes will *implicitly* pop values off the stack to perform the task at hand. For example, if you are attempting to subtract two numbers using the `sub` opcode, it should be clear that `sub` will have to pop off the next two available values before it can perform the calculation. Once the calculation is complete, the result of the value (surprise, surprise) is pushed onto the stack once again.

The `.maxstack` Directive

When you write method implementations using raw CIL, you need to be mindful of a special directive named `.maxstack`. As its name suggests, `.maxstack` establishes the maximum number of variables that may be pushed onto the stack at any given time during the execution of the method. The good news is that the `.maxstack` directive has a default value (8), which should be safe for a vast majority of methods you might be authoring. However, if you want to be explicit, you are able to manually calculate the number of local variables on the stack and define this value explicitly, like so:

```
.method public hidebysig instance void
    Speak() cil managed
{
    // During the scope of this method, exactly
    // 1 value (the string literal) is on the stack.
    .maxstack 1
    ldstr "Hello there..."
    call void [mscorlib]System.Console::WriteLine(string)
    ret
}
```

Declaring Local Variables in CIL

Let's first check out how to declare a local variable. Assume you want to build a method in CIL named `MyLocalVariables()` that takes no arguments and returns `void`. Within the method, you want to define three local variables of type `System.String`, `System.Int32`, and `System.Object`. In C#, this member would appear as follows (recall that locally scoped variables do not receive a default value and should be set to an initial state before further use):

```
public static void MyLocalVariables()
{
    string myStr = "CIL code is fun!";
    int myInt = 33;
    object myObj = new object();
}
```

If you were to construct `MyLocalVariables()` directly in CIL, you could author the following:

```
.method public hidebysig static void
    MyLocalVariables() cil managed
{
    .maxstack 8
    // Define three local variables.
    .locals init ([0] string myStr, [1] int32 myInt, [2] object myObj)
```

```

// Load a string onto the virtual execution stack.
ldstr "CIL code is fun!"
// Pop off current value and store in local variable [0].
stloc.0

// Load a constant of type "i4"
// (shorthand for int32) set to the value 33.
ldc.i4 33
// Pop off current value and store in local variable [1].
stloc.1

// Create a new object and place on stack.
newobj instance void [mscorlib]System.Object::.ctor()
// Pop off current value and store in local variable [2].
stloc.2
ret
}

```

As you can see, the first step taken to allocate local variables in raw CIL is to use the `.locals` directive, which is paired with the `init` attribute. Within the scope of the related parentheses, your goal is to associate a given numerical index to each variable (seen here as `[0]`, `[1]`, and `[2]`). As you can see, each index is identified by its data type and an optional variable name. After the local variables have been defined, you load a value onto the stack (using the various load-centric opcodes) and store the value within the local variable (using the various storage-centric opcodes).

Mapping Parameters to Local Variables in CIL

You have already seen how to declare local variables in raw CIL using the `.locals init` directive; however, you have yet to see exactly how to map incoming parameters to local methods. Consider the following static C# method:

```

public static int Add(int a, int b)
{
    return a + b;
}

```

This innocent-looking method has a lot to say in terms of CIL. First, the incoming arguments (`a` and `b`) must be pushed onto the virtual execution stack using the `ldarg` (load argument) opcode. Next, the `add` opcode will be used to pop the next two values off the stack and find the summation and store the value on the stack yet again. Finally, this sum is popped off the stack and returned to the caller via the `ret` opcode. If you were to disassemble this C# method using `ildasm.exe`, you would find numerous additional tokens injected by `csc.exe`, but the crux of the CIL code is quite simple.

```

.method public hidebysig static int32 Add(int32 a,
    int32 b) cil managed
{
    .maxstack 2
    ldarg.0 // Load "a" onto the stack.
    ldarg.1 // Load "b" onto the stack.
    add     // Add both values.
    ret
}

```

The Hidden this Reference

Notice that the two incoming arguments (a and b) are referenced within the CIL code using their indexed position (index 0 and index 1), given that the virtual execution stack begins indexing at position 0.

One thing to be mindful of when you are examining or authoring CIL code is that every nonstatic method that takes incoming arguments automatically receives an implicit additional parameter, which is a reference to the current object (think the C# `this` keyword). Given this, if the `Add()` method were defined as *nonstatic*, like so:

```
// No longer static!
public int Add(int a, int b)
{
    return a + b;
}
```

the incoming a and b arguments are loaded using `ldarg.1` and `ldarg.2` (rather than the expected `ldarg.0` and `ldarg.1` opcodes). Again, the reason is that slot 0 actually contains the implicit `this` reference. Consider the following pseudocode:

```
// This is JUST pseudo-code!
.method public hidebysig static int32 AddTwoIntParams(
    MyClass_HiddenThisPointer this, int32 a, int32 b) cil managed
{
    ldarg.0 // Load MyClass_HiddenThisPointer onto the stack.
    ldarg.1 // Load "a" onto the stack.
    ldarg.2 // Load "b" onto the stack.
    ...
}
```

Representing Iteration Constructs in CIL

Iteration constructs in the C# programming language are represented using the `for`, `foreach`, `while`, and `do` keywords, each of which has a specific representation in CIL. Consider the following classic `for` loop:

```
public static void CountToTen()
{
    for(int i = 0; i < 10; i++)
        ;
}
```

Now, as you may recall, the `br` opcodes (`br`, `blt`, and so on) are used to control a break in flow when some condition has been met. In this example, you have set up a condition in which the `for` loop should break out of its cycle when the local variable `i` is equal to or greater than the value of 10. With each pass, the value of 1 is added to `i`, at which point the test condition is yet again evaluated.

Also recall that when you use any of the CIL branching opcodes, you will need to define a specific code label (or two) that marks the location to jump to when the condition is indeed true. Given these points, ponder the following (augmented) CIL code generated via `ildasm.exe` (including the autogenerated code labels):

```
.method public hidebysig static void CountToTen() cil managed
{
    .maxstack 2
    .locals init ([0] int32 i) // Init the local integer "i".
    IL_0000: ldc.i4.0           // Load this value onto the stack.
    IL_0001: stloc.0           // Store this value at index "0".
    IL_0002: br.s IL_0008      // Jump to IL_0008.
    IL_0004: ldloc.0           // Load value of variable at index 0.
    IL_0005: ldc.i4.1         // Load the value "1" on the stack.
    IL_0006: add              // Add current value on the stack at index 0.
    IL_0007: stloc.0         // Store the result back to the stack.
    IL_0008: ldloc.0         // Load value at index "0".
    IL_0009: ldc.i4.s 10      // Load value of "10" onto the stack.
    IL_000b: blt.s IL_0004    // Less than? If so, jump back to IL_0004
    IL_000d: ret
}
```

In a nutshell, this CIL code begins by defining the local `int32` and loading it onto the stack. At this point, you jump back and forth between code label `IL_0008` and `IL_0004`, each time bumping the value of `i` by 1 and testing to see whether `i` is still less than the value 10. If so, you exit the method.

■ **Source Code** The `CilTypes` example is included in the Chapter 18 subdirectory.

Building a .NET Assembly with CIL

Now that you've taken a tour of the syntax and semantics of raw CIL, it's time to solidify your current understanding by building a .NET application using nothing but `ilasm.exe` and your text editor of choice. Specifically, your application will consist of a privately deployed, single-file *.dll that contains two class type definitions, and a console-based *.exe that interacts with these types.

Building CILCars.dll

The first order of business is to build the *.dll to be consumed by the client. Open a text editor and create a new *.il file named `CILCars.il`. This single-file assembly will use two external .NET assemblies. Begin by updating your code file as follows:

```
// Reference mscorlib.dll and
// System.Windows.Forms.dll.
.assembly extern mscorlib
{
    .publickeytoken = (B7 7A 5C 56 19 34 E0 89 )
    .ver 4:0:0:0
}
```

```
.assembly extern System.Windows.Forms
{
  .publickeytoken = (B7 7A 5C 56 19 34 E0 89 )
  .ver 4:0:0:0
}
```

// Define the single-file assembly.

```
.assembly CILCars
{
  .hash algorithm 0x00008004
  .ver 1:0:0:0
}
.module CILCars.dll
```

This assembly will contain two class types. The first type, `CILCar`, defines two points of field data (public for simplicity in this example) and a custom constructor. The second type, `CILCarInfo`, defines a single static method named `Display()`, which takes `CILCar` as a parameter and returns `void`. Both types are in the `CILCars` namespace. In terms of CIL, `CILCar` can be implemented as follows:

```
// Implementation of CILCars.CILCar type.
.namespace CILCars
{
  .class public auto ansi beforefieldinit CILCar
  extends [mscorlib]System.Object
  {
    // The field data of the CILCar.
    .field public string petName
    .field public int32 currSpeed

    // The custom constructor simply allows the caller
    // to assign the field data.
    .method public hidebysig specialname rtspecialname
    instance void .ctor(int32 c, string p) cil managed
    {
      .maxstack 8

      // Load first arg onto the stack and call base class ctor.
      ldarg.0 // "this" object, not the int32!
      call instance void [mscorlib]System.Object::.ctor()

      // Now load first and second args onto the stack.
      ldarg.0 // "this" object
      ldarg.1 // int32 arg

      // Store topmost stack (int 32) member in currSpeed field.
      stfld int32 CILCars.CILCar::currSpeed
    }
  }
}
```

```

// Load string arg and store in petName field.
ldarg.0 // "this" object
ldarg.2 // string arg
stfld string CILCars.CILCar::petName
ret
}
}
}

```

Keeping in mind that the real first argument for any nonstatic member is the current object reference, the first block of CIL simply loads the object reference and calls the base class constructor. Next, you push the incoming constructor arguments onto the stack and store them into the type's field data using the `stfld` (store in field) opcode.

Now let's implement the second type in this namespace: `CILCarInfo`. The meat of the type is found within the static `Display()` method. In a nutshell, the role of this method is to take the incoming `CILCar` parameter, extract the values of its field data, and display it in a Windows Forms message box. Here is the complete implementation of `CILCarInfo` (which should be defined within the `CILCars` namespace) with analysis to follow:

```

.class public auto ansi beforefieldinit CILCarInfo
extends [mscorlib]System.Object
{
.method public hidebysig static void
Display(class CILCars.CILCar c) cil managed
{
.maxstack 8

// We need a local string variable.
.locals init ([0] string caption)

// Load string and the incoming CILCar onto the stack.
ldstr "{0}'s speed is:"
ldarg.0

// Now place the value of the CILCar's petName on the
// stack and call the static String.Format() method.
ldfld string CILCars.CILCar::petName
call string [mscorlib]System.String::Format(string, object)
stloc.0

// Now load the value of the currSpeed field and get its string
// representation (note call to ToString()).
ldarg.0
ldflda int32 CILCars.CILCar::currSpeed
call instance string [mscorlib]System.Int32::ToString()
ldloc.0

```

```

// Now call the MessageBox.Show() method with loaded values.
call valuetype [System.Windows.Forms]
    System.Windows.Forms.DialogResult
    [System.Windows.Forms]
    System.Windows.Forms.MessageBox::Show(string, string)
pop
ret
}
}

```

Although the amount of CIL code is a bit more than you see in the implementation of `CILCar`, things are still rather straightforward. First, given that you are defining a static method, you don't have to be concerned with the hidden object reference (thus, the `ldarg.0` opcode really does load the incoming `CILCar` argument).

The method begins by loading a string ("`{0}'s speed is`") onto the stack, followed by the `CILCar` argument. After these two values are in place, you load the value of the `petName` field and call the static `System.String.Format()` method to substitute the curly bracket placeholder with the `CILCar`'s pet name.

The same general procedure takes place when processing the `currSpeed` field, but note that you use the `ldflda` opcode, which loads the argument address onto the stack. At this point, you call `System.Int32.ToString()` to transform the value at said address into a string type. Finally, after both strings have been formatted as necessary, you call the `MessageBox.Show()` method.

At this point, you are able to compile your new `*.dll` using `ilasm.exe` with the following command:

```
ilasm /dll CILCars.il
```

and verify the contained CIL using `peverify.exe`, as follows:

```
peverify CILCars.dll
```

Building CILCarClient.exe

Now you can build a simple `*.exe` assembly with a `Main()` method that will do the following:

- Make a `CILCar` object
- Pass the object into the static `CILCarInfo.Display()` method

Create a new file named `CarClient.il` and define external references to `mscorlib.dll` and `CILCars.dll` (don't forget to place a copy of this .NET assembly in the client's application directory!). Next, define a single type (Program) that manipulates the `CILCars.dll` assembly. Here's the complete code:

```

// External assembly refs.
.assembly extern mscorlib
{
    .publickeytoken = (B7 7A 5C 56 19 34 E0 89)
    .ver 4:0:0:0
}
.assembly extern CILCars
{
    .ver 1:0:0:0
}

```

// Our executable assembly.

```
.assembly CarClient
{
    .hash algorithm 0x00008004
    .ver 1:0:0:0
}
.module CarClient.exe
```

// Implementation of Program type.

```
.namespace CarClient
{
    .class private auto ansi beforefieldinit Program
    extends [mscorlib]System.Object
    {
        .method private hidebysig static void
        Main(string[] args) cil managed
        {
            // Marks the entry point of the *.exe.
            .entrypoint
            .maxstack 8

            // Declare a local CilCar variable and push
            // values onto the stack for ctor call.
            .locals init ([0] class
            [CILCars]CILCars.CilCar myCilCar)
            ldc.i4 55
            ldstr "Junior"

            // Make new CilCar; store and load reference.
            newobj instance void
            [CILCars]CILCars.CilCar::.ctor(int32, string)
            stloc.0
            ldloc.0

            // Call Display() and pass in topmost value on stack.
            call void [CILCars]
            CILCars.CilCarInfo::Display(
            class [CILCars]CILCars.CilCar)
            ret
        }
    }
}
```

The one opcode that is important to point out is `.entrypoint`. Recall from the discussion earlier in this chapter that this opcode is used to mark which method of an `*.exe` functions as the entry point of the module. In fact, given that `.entrypoint` is how the CLR identifies the initial method to execute, this method can be called anything, although here you are using the standard method name of `Main()`. The remainder of the CIL code found in the `Main()` method is your basic pushing and popping of stack-based values.

Do note, however, that the creation of a `CilCar` object involves the use of the `newobj` opcode. On a related note, recall that when you want to invoke a member of a type using raw CIL, you use the double-colon syntax and, as always, use the fully qualified name of the type. With this, you can compile your new file

with `ilasm.exe`, verify your assembly with `peverify.exe`, and execute your program. Issue the following commands within your command prompt:

```
ilasm CarClient.il
peverify CarClient.exe
CarClient.exe
```

■ **Source Code** The `CilCars` example is included in the Chapter 18 subdirectory.

Understanding Dynamic Assemblies

To be sure, the process of building a complex .NET application in CIL would be quite the labor of love. On the one hand, CIL is an extremely expressive programming language that allows you to interact with all the programming constructs allowed by the CTS. On the other hand, authoring raw CIL is tedious, error-prone, and painful. While it is true that knowledge is power, you might indeed wonder just how important it is to commit the laws of CIL syntax to memory. The answer is, “It depends.” To be sure, most of your .NET programming endeavors will not require you to view, edit, or author CIL code. However, with the CIL primer behind you, you are now ready to investigate the world of dynamic assemblies (as opposed to static assemblies) and the role of the `System.Reflection.Emit` namespace.

The first question you may have is, “What exactly is the difference between static and dynamic assemblies?” By definition, *static assemblies* are .NET binaries loaded directly from disk storage, meaning they are located somewhere on your hard drive in a physical file (or possibly a set of files in the case of a multifile assembly) at the time the CLR requests them. As you might guess, every time you compile your C# source code, you end up with a static assembly.

A *dynamic assembly*, on the other hand, is created in memory, on the fly, using the types provided by the `System.Reflection.Emit` namespace. The `System.Reflection.Emit` namespace makes it possible to create an assembly and its modules, type definitions, and CIL implementation logic at *runtime*. After you have done so, you are then free to save your in-memory binary to disk. This, of course, results in a new static assembly. To be sure, the process of building a dynamic assembly using the `System.Reflection.Emit` namespace does require some level of understanding regarding the nature of CIL opcodes.

Although creating dynamic assemblies is a fairly advanced (and uncommon) programming task, they can be useful under various circumstances. Here’s an example:

- You are building a .NET programming tool that needs to generate assemblies on demand based on user input.
- You are building a program that needs to generate proxies to remote types on the fly, based on the obtained metadata.
- You want to load a static assembly and dynamically insert new types into the binary image.

This being said, let’s check out the types within `System.Reflection.Emit`.

Exploring the System.Reflection.Emit Namespace

Creating a dynamic assembly requires you to have some familiarity with CIL opcodes, but the types of the `System.Reflection.Emit` namespace hide the complexity of CIL as much as possible. For example, rather than directly specifying the necessary CIL directives and attributes to define a class type, you can simply use the `TypeBuilder` class. Likewise, if you want to define a new instance-level constructor, you have no need

to emit the `specialname`, `rtspecialname`, or `.ctor` token; rather, you can use the `ConstructorBuilder`. Table 18-8 documents the key members of the `System.Reflection.Emit` namespace.

Table 18-8. *Select Members of the System.Reflection.Emit Namespace*

| Members | Meaning in Life |
|---|--|
| <code>AssemblyBuilder</code> | Used to create an assembly (*.dll or *.exe) at runtime. *.exes must call the <code>ModuleBuilder.SetEntryPoint()</code> method to set the method that is the entry point to the module. If no entry point is specified, a *.dll will be generated. |
| <code>ModuleBuilder</code> | Used to define the set of modules within the current assembly. |
| <code>EnumBuilder</code> | Used to create a .NET enumeration type. |
| <code>TypeBuilder</code> | May be used to create classes, interfaces, structures, and delegates within a module at runtime. |
| <code>MethodBuilder</code> <code>LocalBuilder</code> <code>PropertyBuilder</code> <code>FieldBuilder</code> <code>ConstructorBuilder</code> <code>CustomAttributeBuilder</code> <code>ParameterBuilder</code> <code>EventBuilder</code> | Used to create type members (such as methods, local variables, properties, constructors, and attributes) at runtime. |
| <code>ILGenerator</code> | Emits CIL opcodes into a given type member. |
| <code>OpCodes</code> | Provides numerous fields that map to CIL opcodes. This type is used in conjunction with the various members of <code>System.Reflection.Emit.ILGenerator</code> . |

In general, the types of the `System.Reflection.Emit` namespace allow you to represent raw CIL tokens programmatically during the construction of your dynamic assembly. You will see many of these members in the example that follows; however, the `ILGenerator` type is worth checking out straightaway.

The Role of the System.Reflection.Emit.ILGenerator

As its name implies, the `ILGenerator` type's role is to inject CIL opcodes into a given type member. However, you cannot directly create `ILGenerator` objects, as this type has no public constructors; rather, you receive an `ILGenerator` type by calling specific methods of the builder-centric types (such as the `MethodBuilder` and `ConstructorBuilder` types). Here's an example:

```
// Obtain an ILGenerator from a ConstructorBuilder
// object named "myCtorBuilder".
ConstructorBuilder myCtorBuilder =
    new ConstructorBuilder(/* ...various args... */);

ILGenerator myCILGen = myCtorBuilder.GetILGenerator();
```

Once you have an `ILGenerator` in your hands, you are then able to emit the raw CIL opcodes using any number of methods. Table 18-9 documents some (but not all) methods of `ILGenerator`.

Table 18-9. Various Methods of *ILGenerator*

| Method | Meaning in Life |
|------------------------------------|--|
| <code>BeginCatchBlock()</code> | Begins a catch block |
| <code>BeginExceptionBlock()</code> | Begins an exception scope for an exception |
| <code>BeginFinallyBlock()</code> | Begins a finally block |
| <code>BeginScope()</code> | Begins a lexical scope |
| <code>DeclareLocal()</code> | Declares a local variable |
| <code>DefineLabel()</code> | Declares a new label |
| <code>Emit()</code> | Is overloaded numerous times to allow you to emit CIL opcodes |
| <code>EmitCall()</code> | Pushes a call or callvirt opcode into the CIL stream |
| <code>EmitWriteLine()</code> | Emits a call to <code>Console.WriteLine()</code> with different types of values |
| <code>EndExceptionBlock()</code> | Ends an exception block |
| <code>EndScope()</code> | Ends a lexical scope |
| <code>ThrowException()</code> | Emits an instruction to throw an exception |
| <code>UsingNamespace()</code> | Specifies the namespace to be used in evaluating locals and watches for the current active lexical scope |

The key method of *ILGenerator* is `Emit()`, which works in conjunction with the `System.Reflection.Emit.OpCodes` class type. As mentioned earlier in this chapter, this type exposes a good number of read-only fields that map to raw CIL opcodes. The full set of these members are all documented within online help, and you will see various examples in the pages that follow.

Emitting a Dynamic Assembly

To illustrate the process of defining a .NET assembly at runtime, let's walk through the process of creating a single-file dynamic assembly named `MyAssembly.dll`. Within this module is a class named `HelloWorld`. The `HelloWorld` class supports a default constructor and a custom constructor that is used to assign the value of a private member variable (`theMessage`) of type `string`. In addition, `HelloWorld` supports a public instance method named `SayHello()`, which prints a greeting to the standard I/O stream, and another instance method named `GetMsg()`, which returns the internal private string. In effect, you are going to programmatically generate the following class type:

```
// This class will be created at runtime
// using System.Reflection.Emit.
public class HelloWorld
{
    private string theMessage;
    HelloWorld() {}
    HelloWorld(string s) {theMessage = s;}

    public string GetMsg() {return theMessage;}
    public void SayHello()
    {
        System.Console.WriteLine("Hello from the HelloWorld class!");
    }
}
```

Assume you have created a new Visual Studio Console Application project named `DynamicAsmBuilder` and you import the `System.Reflection`, `System.Reflection.Emit`, and `System.Threading` namespaces. Define a static method named `CreateMyAsm()` in the `Program` class. This single method is in charge of the following:

- Defining the characteristics of the dynamic assembly (name, version, etc.)
- Implementing the `HelloClass` type
- Saving the in-memory assembly to a physical file

Also note that the `CreateMyAsm()` method takes as a single parameter a `System.AppDomain` type, which will be used to obtain access to the `AssemblyBuilder` type associated with the current application domain (see Chapter 17 for a discussion of .NET application domains). Here is the complete code, with analysis to follow:

// The caller sends in an AppDomain type.

```
public static void CreateMyAsm(AppDomain curAppDomain)
{
    // Establish general assembly characteristics.
    AssemblyName assemblyName = new AssemblyName();
    assemblyName.Name = "MyAssembly";
    assemblyName.Version = new Version("1.0.0.0");

    // Create new assembly within the current AppDomain.
    AssemblyBuilder assembly =
        curAppDomain.DefineDynamicAssembly(assemblyName,
            AssemblyBuilderAccess.Save);

    // Given that we are building a single-file
// assembly, the name of the module is the same as the assembly.
    ModuleBuilder module =
        assembly.DefineDynamicModule("MyAssembly", "MyAssembly.dll");

    // Define a public class named "HelloWorld".
    TypeBuilder helloWorldClass = module.DefineType("MyAssembly.HelloWorld",
        TypeAttributes.Public);

    // Define a private String member variable named "theMessage".
    FieldBuilder msgField =
        helloWorldClass.DefineField("theMessage", Type.GetType("System.String"),
            FieldAttributes.Private);

    // Create the custom ctor.
    Type[] constructorArgs = new Type[1];
    constructorArgs[0] = typeof(string);
    ConstructorBuilder constructor =
        helloWorldClass.DefineConstructor(MethodAttributes.Public,
            CallingConventions.Standard,
            constructorArgs);
    ILGenerator constructorIL = constructor.GetILGenerator();
    constructorIL.Emit(OpCodes.Ldarg_0);
    Type objectClass = typeof(object);
```

```

ConstructorInfo superConstructor =
    objectClass.GetConstructor(new Type[0]);
constructorIL.Emit(OpCodes.Call, superConstructor);
constructorIL.Emit(OpCodes.Ldarg_0);
constructorIL.Emit(OpCodes.Ldarg_1);
constructorIL.Emit(OpCodes.Stfld, msgField);
constructorIL.Emit(OpCodes.Ret);

// Create the default ctor.
helloWorldClass.DefineDefaultConstructor(MethodAttributes.Public);
// Now create the GetMsg() method.
MethodBuilder getMsgMethod =
    helloWorldClass.DefineMethod("GetMsg", MethodAttributes.Public,
        typeof(string), null);
ILGenerator methodIL = getMsgMethod.GetILGenerator();
methodIL.Emit(OpCodes.Ldarg_0);
methodIL.Emit(OpCodes.Ldfld, msgField);
methodIL.Emit(OpCodes.Ret);

// Create the SayHello method.
MethodBuilder sayHiMethod =
    helloWorldClass.DefineMethod("SayHello",
        MethodAttributes.Public, null, null);
methodIL = sayHiMethod.GetILGenerator();
methodIL.EmitWriteLine("Hello from the HelloWorld class!");
methodIL.Emit(OpCodes.Ret);

// "Bake" the class HelloWorld.
// (Baking is the formal term for emitting the type.)
helloWorldClass.CreateType();

// (Optionally) save the assembly to file.
assembly.Save("MyAssembly.dll");
}

```

Emitting the Assembly and Module Set

The method body begins by establishing the minimal set of characteristics about your assembly, using the `AssemblyName` and `Version` types (defined in the `System.Reflection` namespace). Next, you obtain an `AssemblyBuilder` type via the instance-level `AppDomain.DefineDynamicAssembly()` method (recall the caller will pass an `AppDomain` reference into the `CreateMyAsm()` method), like so:

```

// Establish general assembly characteristics
// and gain access to the AssemblyBuilder type.
public static void CreateMyAsm(AppDomain curAppDomain)
{
    AssemblyName assemblyName = new AssemblyName();
    assemblyName.Name = "MyAssembly";
    assemblyName.Version = new Version("1.0.0.0");
}

```

```
// Create new assembly within the current AppDomain.
AssemblyBuilder assembly =
    curAppDomain.DefineDynamicAssembly(assemblyName,
    AssemblyBuilderAccess.Save);
...
}
```

As you can see, when calling `AppDomain.DefineDynamicAssembly()`, you must specify the access mode of the assembly you want to define, the most common values of which are shown in Table 18-10.

Table 18-10. *Common Values of the AssemblyBuilderAccess Enumeration*

| Value | Meaning in Life |
|----------------|--|
| ReflectionOnly | Represents that a dynamic assembly can only be reflected over |
| Run | Represents that a dynamic assembly can be executed in memory but not saved to disk |
| RunAndSave | Represents that a dynamic assembly can be executed in memory and saved to disk |
| Save | Represents that a dynamic assembly can be saved to disk but not executed in memory |

The next task is to define the module set for your new assembly. Given that the assembly is a single-file unit, you need to define only a single module. If you were to build a multifile assembly using the `DefineDynamicModule()` method, you would specify an optional second parameter that represents the name of a given module (e.g., `myMod.dotnetmodule`). However, when creating a single-file assembly, the name of the module will be identical to the name of the assembly itself. In any case, once the `DefineDynamicModule()` method has returned, you are provided with a reference to a valid `ModuleBuilder` type.

```
// The single-file assembly.
ModuleBuilder module =
    assembly.DefineDynamicModule("MyAssembly", "MyAssembly.dll");
```

The Role of the ModuleBuilder Type

`ModuleBuilder` is the key type used during the development of dynamic assemblies. As you would expect, `ModuleBuilder` supports a number of members that allow you to define the set of types contained within a given module (classes, interfaces, structures, etc.) as well as the set of embedded resources (string tables, images, etc.) contained within. Table 18-11 describes a few of the creation-centric methods. (Do note that each method will return to you a related type that represents the type you want to construct.)

Table 18-11. *Select Members of the ModuleBuilder Type*

| Method | Meaning in Life |
|-------------------------------|---|
| <code>DefineEnum()</code> | Used to emit a .NET enum definition |
| <code>DefineResource()</code> | Defines a managed embedded resource to be stored in this module |
| <code>DefineType()</code> | Constructs a <code>TypeBuilder</code> , which allows you to define value types, interfaces, and class types (including delegates) |

The key member of the `ModuleBuilder` class to be aware of is `DefineType()`. In addition to specifying the name of the type (via a simple string), you will also use the `System.Reflection.TypeAttributes` enum to describe the format of the type itself. Table 18-12 lists some (but not all) of the key members of the `TypeAttributes` enumeration.

Table 18-12. *Select Members of the TypeAttributes Enumeration*

| Member | Meaning in Life |
|-------------------|--|
| Abstract | Specifies that the type is abstract |
| Class | Specifies that the type is a class |
| Interface | Specifies that the type is an interface |
| NestedAssembly | Specifies that the class is nested with assembly visibility and is thus accessible only by methods within its assembly |
| NestedFamANDAssem | Specifies that the class is nested with assembly and family visibility and is thus accessible only by methods lying in the intersection of its family and assembly |
| NestedFamily | Specifies that the class is nested with family visibility and is thus accessible only by methods within its own type and any subtypes |
| NestedFamORAssem | Specifies that the class is nested with family or assembly visibility and is thus accessible only by methods lying in the union of its family and assembly |
| NestedPrivate | Specifies that the class is nested with private visibility |
| NestedPublic | Specifies that the class is nested with public visibility |
| NotPublic | Specifies that the class is not public |
| Public | Specifies that the class is public |
| Sealed | Specifies that the class is concrete and cannot be extended |
| Serializable | Specifies that the class can be serialized |

Emitting the HelloWorld Type and the String Member Variable

Now that you have a better understanding of the role of the `ModuleBuilder.CreateType()` method, let's examine how you can emit the public `HelloWorld` class type and the private string variable.

```
// Define a public class named "MyAssembly.HelloWorld".
TypeBuilder helloWorldClass = module.DefineType("MyAssembly.HelloWorld",
    TypeAttributes.Public);

// Define a private String member variable named "theMessage".
FieldBuilder msgField =
    helloWorldClass.DefineField("theMessage",
        Type.GetType("System.String"),
        FieldAttributes.Private);
```

Notice how the `TypeBuilder.DefineField()` method provides access to a `FieldBuilder` type. The `TypeBuilder` class also defines other methods that provide access to other “builder” types. For example, `DefineConstructor()` returns a `ConstructorBuilder`, `DefineProperty()` returns a `PropertyBuilder`, and so forth.

Emitting the Constructors

As mentioned earlier, the `TypeBuilder.DefineConstructor()` method can be used to define a constructor for the current type. However, when it comes to implementing the constructor of `HelloClass`, you need to inject raw CIL code into the constructor body, which is responsible for assigning the incoming parameter to the internal private string. To obtain an `ILGenerator` type, you call the `GetILGenerator()` method from the respective “builder” type you have reference to (in this case, the `ConstructorBuilder` type).

The `Emit()` method of the `ILGenerator` class is the entity in charge of placing CIL into a member implementation. `Emit()` itself makes frequent use of the `OpCodes` class type, which exposes the opcode set of CIL using read-only fields. For example, `OpCodes.Ret` signals the return of a method call, `OpCodes.Stfld` makes an assignment to a member variable, and `OpCodes.Call` is used to call a given method (in this case, the base class constructor). That said, ponder the following constructor logic:

```
// Create the custom constructor taking
// a single System.String argument.
Type[] constructorArgs = new Type[1];
constructorArgs[0] = typeof(string);
ConstructorBuilder constructor =
    helloWorldClass.DefineConstructor(MethodAttributes.Public,
        CallingConventions.Standard, constructorArgs);

// Now emit the necessary CIL into the ctor.
ILGenerator constructorIL = constructor.GetILGenerator();
constructorIL.Emit(OpCodes.Ldarg_0);
Type objectClass = typeof(object);
ConstructorInfo superConstructor = objectClass.GetConstructor(new Type[0]);
constructorIL.Emit(OpCodes.Call, superConstructor); // Call base class ctor.

// Load the object's "this" pointer on the stack.
constructorIL.Emit(OpCodes.Ldarg_0);

// Load incoming argument on virtual stack and store in msgField.
constructorIL.Emit(OpCodes.Ldarg_1);
constructorIL.Emit(OpCodes.Stfld, msgField); // Assign msgField.
constructorIL.Emit(OpCodes.Ret);           // Return.
```

Now, as you are well aware, as soon as you define a custom constructor for a type, the default constructor is silently removed. To redefine the no-argument constructor, simply call the `DefineDefaultConstructor()` method of the `TypeBuilder` type as follows:

```
// Reinsert the default ctor.
helloWorldClass.DefineDefaultConstructor(MethodAttributes.Public);
```

This single call emits the standard CIL code used to define a default constructor.

```
.method public hidebysig specialname rtspecialname
    instance void .ctor() cil managed
{
    .maxstack 1
    ldarg.0
    call instance void [mscorlib]System.Object::.ctor()
    ret
}
```

Emitting the SayHello() Method

Last but not least, let's examine the process of emitting the SayHello() method. The first task is to obtain a MethodBuilder type from the helloWorldClass variable. After you do this, you define the method and obtain the underlying ILGenerator to inject the CIL instructions, like so:

```
// Create the SayHello method.
MethodBuilder sayHiMethod =
    helloWorldClass.DefineMethod("SayHello",
        MethodAttributes.Public, null, null);
methodIL = sayHiMethod.GetILGenerator();

// Write a line to the Console.
methodIL.EmitWriteLine("Hello from the HelloWorld class!");
methodIL.Emit(OpCodes.Ret);
```

Here you have established a public method (MethodAttributes.Public) that takes no parameters and returns nothing (marked by the null entries contained in the DefineMethod() call). Also note the EmitWriteLine() call. This helper member of the ILGenerator class automatically writes a line to the standard output with minimal fuss and bother.

Using the Dynamically Generated Assembly

Now that you have the logic in place to create and save your assembly, all that's needed is a class to trigger the logic. To come full circle, assume your current project defines a second class named AsmReader. The logic in Main() obtains the current AppDomain via the Thread.GetDomain() method that will be used to host the assembly you will dynamically create. Once you have a reference, you are able to call the CreateMyAsm() method.

To make things a bit more interesting, after the call to CreateMyAsm() returns, you will exercise some late binding (see Chapter 15) to load your newly created assembly into memory and interact with the members of the HelloWorld class. Update your Main() method as follows:

```
static void Main(string[] args)
{
    Console.WriteLine("***** The Amazing Dynamic Assembly Builder App *****");
    // Get the application domain for the current thread.
    AppDomain curAppDomain = Thread.GetDomain();

    // Create the dynamic assembly using our helper f(x).
    CreateMyAsm(curAppDomain);
    Console.WriteLine("-> Finished creating MyAssembly.dll.");

    // Now load the new assembly from file.
    Console.WriteLine("-> Loading MyAssembly.dll from file.");
    Assembly a = Assembly.Load("MyAssembly");

    // Get the HelloWorld type.
    Type hello = a.GetType("MyAssembly.HelloWorld");
```

```

// Create HelloWorld object and call the correct ctor.
Console.WriteLine("-> Enter message to pass HelloWorld class: ");
string msg = Console.ReadLine();
object[] ctorArgs = new object[1];
ctorArgs[0] = msg;
object obj = Activator.CreateInstance(hello, ctorArgs);

// Call SayHello and show returned string.
Console.WriteLine("-> Calling SayHello() via late binding.");
MethodInfo mi = hello.GetMethod("SayHello");
mi.Invoke(obj, null);

// Invoke method.
mi = hello.GetMethod("GetMsg");
Console.WriteLine(mi.Invoke(obj, null));
}

```

In effect, you have just created a .NET assembly that is able to create and execute .NET assemblies at runtime! That wraps up the examination of CIL and the role of dynamic assemblies. I hope this chapter has deepened your understanding of the .NET type system, the syntax and semantics of CIL, and how the C# compiler processes your code at compile time.

■ **Source Code** The `DynamicAsmBuilder` project is included in the Chapter 18 subdirectory.

Summary

This chapter provided an overview of the syntax and semantics of CIL. Unlike higher-level managed languages such as C#, CIL does not simply define a set of keywords but provides directives (used to define the structure of an assembly and its types), attributes (which further qualify a given directive), and opcodes (which are used to implement type members).

You were introduced to a few CIL-centric programming tools and learned how to alter the contents of a .NET assembly with new CIL instructions using round-trip engineering. After this point, you spent time learning how to establish the current (and referenced) assembly, namespaces, types, and members. I wrapped up with a simple example of building a .NET code library and executable using little more than CIL, command-line tools, and a bit of elbow grease.

Finally, you took an introductory look at the process of creating a *dynamic assembly*. Using the `System.Reflection.Emit` namespace, it is possible to define a .NET assembly in memory at runtime. As you have seen firsthand, using this particular API requires you to know the semantics of CIL code in some detail. While the need to build dynamic assemblies is certainly not a common task for most .NET applications, it can be useful for those of you who need to build support tools and other programming utilities.

PART VI



Introducing the .NET Base Class Libraries

CHAPTER 19



Multithreaded, Parallel, and Async Programming

Nobody enjoys working with an application that is sluggish during its execution. Moreover, nobody enjoys starting a task in an application (perhaps initiated by clicking a toolbar item) that prevents other parts of the program from being as responsive as possible. Before the release of .NET, building applications that had the ability to perform multiple tasks typically required authoring complex C++ code that used the Windows threading APIs. Thankfully, the .NET platform provides a number of ways for you to build software that can perform complex operations on unique paths of execution, with far fewer pain points.

This chapter begins by defining the overall nature of a “multithreaded application.” Next, you will revisit the .NET delegate type to investigate its intrinsic support for *asynchronous method invocations*. As you’ll see, this technique allows you to invoke a method on a secondary thread of execution without needing to manually create or configure the thread itself.

Next, you’ll be introduced to the original threading namespace that has shipped since .NET 1.0, specifically `System.Threading`. Here you’ll examine numerous types (`Thread`, `ThreadStart`, etc.) that allow you to explicitly create additional threads of execution and synchronize your shared resources, which helps ensure that multiple threads can share data in a nonvolatile manner.

The remaining parts of this chapter will examine three more recent techniques .NET developers can use to build multithreaded software, specifically the Task Parallel Library (TPL), Parallel LINQ (PLINQ), and the new intrinsic asynchronous keywords of C# (`async` and `await`). As you will see, these features can dramatically simplify how you can build responsive multithreaded software applications.

The Process/AppDomain/Context/Thread Relationship

In Chapter 17, a *thread* was defined as a path of execution within an executable application. While many .NET applications can live happy and productive single-threaded lives, an assembly’s primary thread (spawned by the CLR when `Main()` executes) may create secondary threads of execution at any time to perform additional units of work. By creating additional threads, you can build more responsive (but not necessarily faster executing on single-core machines) applications.

The `System.Threading` namespace was released with .NET 1.0 and offers one approach to build multithreaded applications. The `Thread` class is perhaps the core type, as it represents a given thread. If you want to programmatically obtain a reference to the thread currently executing a given member, simply call the static `Thread.CurrentThread` property, like so:

```
static void ExtractExecutingThread()
{
    // Get the thread currently
    // executing this method.
    Thread currThread = Thread.CurrentThread;
}
```

Under the .NET platform, there is *not* a direct one-to-one correspondence between application domains and threads. In fact, a given `AppDomain` can have numerous threads executing within it at any given time. Furthermore, a particular thread is not confined to a single application domain during its lifetime. Threads are free to cross application domain boundaries as the Windows OS thread scheduler and the .NET CLR see fit.

Although active threads can be moved between `AppDomain` boundaries, a given thread can execute within only a single application domain at any point in time (in other words, it is impossible for a single thread to be doing work in more than one `AppDomain` at once). When you want to programmatically gain access to the `AppDomain` that is hosting the current thread, call the static `Thread.GetDomain()` method, like so:

```
static void ExtractAppDomainHostingThread()
{
    // Obtain the AppDomain hosting the current thread.
    AppDomain ad = Thread.GetDomain();
}
```

A single thread may also be moved into a particular context at any given time, and it may be relocated within a new context at the whim of the CLR. When you want to obtain the current context a thread happens to be executing in, use the static `Thread.CurrentContext` property (which returns a `System.Runtime.Remoting.Contexts.Context` object), like so:

```
static void ExtractCurrentThreadContext()
{
    // Obtain the context under which the
    // current thread is operating.
    Context ctx = Thread.CurrentContext;
}
```

Again, the CLR is the entity that is in charge of moving threads into (and out of) application domains and contexts. As a .NET developer, you can usually remain blissfully unaware where a given thread ends up (or exactly when it is placed into its new boundary). Nevertheless, you should be aware of the various ways of obtaining the underlying primitives.

The Problem of Concurrency

One of the many “joys” (read: painful aspects) of multithreaded programming is that you have little control over how the underlying operating system or the CLR uses its threads. For example, if you craft a block of code that creates a new thread of execution, you cannot guarantee that the thread executes immediately.

Rather, such code only instructs the OS/CLR to execute the thread as soon as possible (which is typically when the thread scheduler gets around to it).

Furthermore, given that threads can be moved between application and contextual boundaries as required by the CLR, you must be mindful of which aspects of your application are *thread-volatile* (e.g., subject to multithreaded access) and which operations are *atomic* (thread-volatile operations are the dangerous ones!).

To illustrate the problem, assume a thread is invoking a method of a specific object. Now assume that this thread is instructed by the thread scheduler to suspend its activity to allow another thread to access the same method of the same object.

If the original thread was not completely finished with its operation, the second incoming thread may be viewing an object in a partially modified state. At this point, the second thread is basically reading bogus data, which is sure to give way to extremely odd (and hard to find) bugs, which are even harder to replicate and debug.

Atomic operations, on the other hand, are always safe in a multithreaded environment. Sadly, there are few operations in the .NET base class libraries that are guaranteed to be atomic. Even the act of assigning a value to a member variable is not atomic! Unless the .NET Framework 4.6 SDK documentation specifically says an operation is atomic, you must assume it is thread-volatile and take precautions.

The Role of Thread Synchronization

At this point, it should be clear that multithreaded programs are in themselves quite volatile, as numerous threads can operate on the shared resources at (more or less) the same time. To protect an application's resources from possible corruption, .NET developers must use any number of threading primitives (such as locks, monitors, and the [Synchronization] attribute or language keyword support) to control access among the executing threads.

Although the .NET platform cannot make the difficulties of building robust multithreaded applications completely disappear, the process has been simplified considerably. Using types defined within the System.Threading namespace, the Task Parallel Library (TPL), and the C# `async` and `await` language keywords, you are able to work with multiple threads with minimal fuss and bother.

Before diving into the System.Threading namespace, the TPL, and the C# `async` and `await` keywords, you will begin by examining how the .NET delegate type can be used to invoke a method in an asynchronous manner. While it is most certainly true that since .NET 4.6, the new C# `async` and `await` keywords offer a simpler alternative to asynchronous delegates, it is still important that you know how to interact with code using this approach (trust me; there is a ton of code in production that uses asynchronous delegates).

A Brief Review of the .NET Delegate

Recall that a .NET delegate is essentially a type-safe, object-oriented, function pointer. When you define a .NET delegate type, the C# compiler responds by building a sealed class that derives from System.MulticastDelegate (which in turn derives from System.Delegate). These base classes provide every delegate with the ability to maintain a list of method addresses, all of which may be invoked at a later time. Consider the following BinaryOp delegate, first defined in Chapter 10:

```
// A C# delegate type.
public delegate int BinaryOp(int x, int y);
```

Based on its definition, `BinaryOp` can point to any method taking two integers (by value) as arguments and returning an integer. Once compiled, the defining assembly now contains a full-blown class definition that is dynamically generated when you build your project, based on the delegate declaration. In the case of `BinaryOp`, this class looks more or less like the following (shown in pseudocode):

```
public sealed class BinaryOp : System.MulticastDelegate
{
    public BinaryOp(object target, uint functionAddress);
    public int Invoke(int x, int y);
    public IAsyncResult BeginInvoke(int x, int y,
        AsyncCallback cb, object state);
    public int EndInvoke(IAsyncResult result);
}
```

Recall that the generated `Invoke()` method is used to invoke the methods maintained by a delegate object in a *synchronous manner*. Therefore, the calling thread (such as the primary thread of the application) is forced to wait until the delegate invocation completes. Also recall that in C# the `Invoke()` method does not need to be directly called in code but can be triggered indirectly, under the hood, when applying “normal” method invocation syntax.

Consider the following Console Application program (`SyncDelegateReview`), which invokes the static `Add()` method in a synchronous (aka blocking) manner (be sure to import the `System.Threading` namespace into your C# code file, as you will be calling the `Thread.Sleep()` method):

```
namespace SyncDelegateReview
{
    public delegate int BinaryOp(int x, int y);

    class Program
    {
        static void Main(string[] args)
        {
            Console.WriteLine("***** Synch Delegate Review *****");

            // Print out the ID of the executing thread.
            Console.WriteLine("Main() invoked on thread {0}.",
                Thread.CurrentThread.ManagedThreadId);

            // Invoke Add() in a synchronous manner.
            BinaryOp b = new BinaryOp(Add);

            // Could also write b.Invoke(10, 10);
            int answer = b(10, 10);

            // These lines will not execute until
            // the Add() method has completed.
            Console.WriteLine("Doing more work in Main(!");
            Console.WriteLine("10 + 10 is {0}.", answer);
            Console.ReadLine();
        }
    }
}
```

```

static int Add(int x, int y)
{
    // Print out the ID of the executing thread.
    Console.WriteLine("Add() invoked on thread {0}.",
        Thread.CurrentThread.ManagedThreadId);

    // Pause to simulate a lengthy operation.
    Thread.Sleep(5000);
    return x + y;
}
}
}

```

Within the `Add()` method, you are invoking the static `Thread.Sleep()` method to suspend the calling thread for approximately five seconds to simulate a lengthy task. Given that you are invoking the `Add()` method in a *synchronous* manner, the `Main()` method will not print out the result of the operation until the `Add()` method has completed.

Next, note that the `Main()` method is obtaining access to the current thread (via `Thread.CurrentThread`) and printing the ID of the thread via the `ManagedThreadId` property. This same logic is repeated in the static `Add()` method. As you might suspect, given that all the work in this application is performed exclusively by the primary thread, you find the same ID value displayed to the console.

```

***** Synch Delegate Review *****
Main() invoked on thread 1.
Add() invoked on thread 1.
Doing more work in Main()!
10 + 10 is 20.

Press any key to continue . . .

```

When you run this program, you should notice that a five-second delay takes place before you see the final `Console.WriteLine()` logic in `Main()` execute. Although many (if not most) methods may be called synchronously without ill effect, .NET delegates can be instructed to call their methods asynchronously if necessary.

■ **Source Code** The `SyncDelegateReview` project is located in the Chapter 19 subdirectory.

The Asynchronous Nature of Delegates

If you are new to the topic of multithreading, you might wonder what exactly an *asynchronous* method invocation is all about. As you are no doubt fully aware, some programming operations take time. Although the previous `Add()` was purely illustrative in nature, imagine that you built a single-threaded application that is invoking a method on a remote web service operation, calling a method performing a long-running database query, downloading a large document, or writing 500 lines of text to an external file. While performing these operations, the application could appear to hang for some amount of time. Until the task at hand has been processed, all other aspects of this program (such as menu activation, toolbar clicking, or console output) are suspended (which can aggravate users).

Therefore, the question is, how can you tell a delegate to invoke a method on a separate thread of execution to simulate numerous tasks performing “at the same time”? The good news is that every .NET delegate type is automatically equipped with this capability. The even better news is that you are *not* required to directly dive into the details of the `System.Threading` namespace to do so (although these entities can quite naturally work hand in hand).

The BeginInvoke() and EndInvoke() Methods

When the C# compiler processes the `delegate` keyword, the dynamically generated class defines two methods named `BeginInvoke()` and `EndInvoke()`. Given the definition of the `BinaryOp` delegate, these methods are prototyped as follows:

```
public sealed class BinaryOp : System.MulticastDelegate
{
    ...
    // Used to invoke a method asynchronously.
    public IAsyncResult BeginInvoke(int x, int y,
        AsyncCallback cb, object state);

    // Used to fetch the return value
    // of the invoked method.
    public int EndInvoke(IAsyncResult result);
}
```

The first set of parameters passed into `BeginInvoke()` will be based on the format of the C# delegate (two integers, in the case of `BinaryOp`). The final two arguments will always be `System.AsyncCallback` and `System.Object`. You’ll examine the role of these parameters shortly; for the time being, though, I’ll supply `null` for each. Also note that the return value of `EndInvoke()` is an integer, based on the return type of `BinaryOp`, while the single parameter of this method is always of type `IAsyncResult`.

The System.IAsyncResult Interface

The `BeginInvoke()` method always returns an object implementing the `IAsyncResult` interface, while `EndInvoke()` requires an `IAsyncResult`-compatible type as its sole parameter. The `IAsyncResult`-compatible object returned from `BeginInvoke()` is basically a coupling mechanism that allows the calling thread to obtain the result of the asynchronous method invocation at a later time via `EndInvoke()`. The `IAsyncResult` interface (defined in the `System` namespace) is defined as follows:

```
public interface IAsyncResult
{
    object AsyncState { get; }
    WaitHandle AsyncWaitHandle { get; }
    bool CompletedSynchronously { get; }
    bool IsCompleted { get; }
}
```

In the simplest case, you are able to avoid directly invoking these members. All you have to do is cache the `IAsyncResult`-compatible object returned by `BeginInvoke()` and pass it to `EndInvoke()` when you are ready to obtain the result of the method invocation. As you will see, you are able to invoke the members of an `IAsyncResult`-compatible object when you want to become “more involved” with the process of fetching the method’s return value.

■ **Note** If you asynchronously invoke a method that provides a `void` return value, you can simply “fire and forget.” In such cases, you will never need to cache the `IAAsyncResult`-compatible object or call `EndInvoke()` in the first place (as there is no return value to retrieve).

Invoking a Method Asynchronously

To instruct the `BinaryOp` delegate to invoke `Add()` asynchronously, you will modify the logic in the previous project (feel free to add code to the existing project; however, in your lab downloads, you will find a new Console Application project named `AsyncDelegate`). Update the previous `Main()` method as follows:

```
static void Main(string[] args)
{
    Console.WriteLine("***** Async Delegate Invocation *****");

    // Print out the ID of the executing thread.
    Console.WriteLine("Main() invoked on thread {0}.",
        Thread.CurrentThread.ManagedThreadId);

    // Invoke Add() on a secondary thread.
    BinaryOp b = new BinaryOp(Add);
    IAsyncResult iftAR = b.BeginInvoke(10, 10, null, null);

    // Do other work on primary thread...
    Console.WriteLine("Doing more work in Main()!");

    // Obtain the result of the Add()
    // method when ready.
    int answer = b.EndInvoke(iftAR);
    Console.WriteLine("10 + 10 is {0}.", answer);
    Console.ReadLine();
}
```

If you run this application, you will find that two unique thread IDs are displayed, given that there are in fact multiple threads working within the current `AppDomain`:

```
***** Async Delegate Invocation *****
Main() invoked on thread 1.
Doing more work in Main()!
Add() invoked on thread 3.
10 + 10 is 20.
```

In addition to the unique ID values, you will also notice upon running the application that the `Doing more work in Main()!` message displays immediately, while the secondary thread is occupied attending to its business.

Synchronizing the Calling Thread

If you think carefully about the current implementation of `Main()`, you might realize that the timespan between calling `BeginInvoke()` and `EndInvoke()` is clearly less than five seconds. Therefore, once `Doing more work in Main()!` prints to the console, the calling thread is now blocked and waiting for the secondary thread to complete before being able to obtain the result of the `Add()` method. Therefore, you are effectively making yet another *synchronous call*.

```
static void Main(string[] args)
{
    ...
    BinaryOp b = new BinaryOp(Add);

    // Once the next statement is processed,
    // the calling thread is now blocked until
    // BeginInvoke() completes.
    IAsyncResult iftAR = b.BeginInvoke(10, 10, null, null);

    // This call takes far less than five seconds!
    Console.WriteLine("Doing more work in Main()!");

    // Now we are waiting again for other thread to complete!
    int answer = b.EndInvoke(iftAR);
    ...
}
```

Obviously, asynchronous delegates would lose their appeal if the calling thread had the potential of being blocked under various circumstances. To allow the calling thread to discover whether the asynchronously invoked method has completed its work, the `IAsyncResult` interface provides the `IsCompleted` property. Using this member, the calling thread is able to determine whether the asynchronous call has indeed completed before calling `EndInvoke()`.

If the method has not completed, `IsCompleted` returns `false`, and the calling thread is free to carry on its work. If `IsCompleted` returns `true`, the calling thread is able to obtain the result in the “least blocking manner” possible. Ponder the following update to the `Main()` method:

```
static void Main(string[] args)
{
    ...
    BinaryOp b = new BinaryOp(Add);
    IAsyncResult iftAR = b.BeginInvoke(10, 10, null, null);

    // This message will keep printing until
    // the Add() method is finished.
    while(!iftAR.IsCompleted)
    {
        Console.WriteLine("Doing more work in Main()!");
        Thread.Sleep(1000);
    }
    // Now we know the Add() method is complete.
    int answer = b.EndInvoke(iftAR);
    ...
}
```

Here, you enter a loop that will continue processing the `Console.WriteLine()` statement until the secondary thread has completed. After this has occurred, you can obtain the result of the `Add()` method, knowing full well the method has indeed completed. The call to `Thread.Sleep(1000)` is not necessary for this particular application to function correctly; however, by forcing the primary thread to wait for approximately one second during each iteration, it prevents the same message from printing hundreds of times. Here is the output (your output might differ slightly, based on the speed of your machine and when threads come to life):

```
***** Async Delegate Invocation *****
Main() invoked on thread 1.
Doing more work in Main()!
Add() invoked on thread 3.
Doing more work in Main()!
Doing more work in Main()!
Doing more work in Main()!
Doing more work in Main()!
Doing more work in Main()!
Doing more work in Main()!
10 + 10 is 20.
```

In addition to the `IsCompleted` property, the `IAsyncResult` interface provides the `AsyncWaitHandle` property for more flexible waiting logic. This property returns an instance of the `WaitHandle` type, which exposes a method named `WaitOne()`. The benefit of `WaitHandle.WaitOne()` is that you can specify the maximum wait time. If the specified amount of time is exceeded, `WaitOne()` returns `false`. Ponder the following updated `while` loop, which no longer uses a call to `Thread.Sleep()`:

```
while (!iftAR.AsyncWaitHandle.WaitOne(1000, true))
{
    Console.WriteLine("Doing more work in Main()!");
}
```

While these properties of `IAsyncResult` do provide a way to synchronize the calling thread, they are not the most efficient approach. In many ways, the `IsCompleted` property is much like a really annoying manager (or classmate) who is constantly asking, “Are you done yet?” Thankfully, delegates provide a number of additional (and more elegant) techniques to obtain the result of a method that has been called asynchronously.

■ **Source Code** The `AsyncDelegate` project is located in the Chapter 19 subdirectory.

The Role of the `AsyncCallback` Delegate

Rather than polling a delegate to determine whether an asynchronously invoked method has completed, it would be more efficient to have the secondary thread inform the calling thread when the task is finished. When you want to enable this behavior, you will need to supply an instance of the `System.AsyncCallback` delegate as a parameter to `BeginInvoke()`, which up until this point has been `null`. However, when you do supply an `AsyncCallback` object, the delegate will call the specified method automatically when the asynchronous call has completed.

■ **Note** The callback method will be called on the secondary thread, not the primary thread. This has important implications when using threads within a graphical user interface (WPF or Windows Forms) as controls have thread-affinity, meaning they can be manipulated only by the thread that created them. You'll see some examples of working the threads from a GUI later in this chapter, during the examination of the Task Parallel Library (TPL) and the C# `async` and `await` keywords.

Like any delegate, `AsyncCallback` can invoke methods that match only a specific pattern, which in this case is a method taking `IAsyncResult` as the sole parameter and returning nothing.

```
// Targets of AsyncCallback must match the following pattern.
void MyAsyncCallbackMethod(IAsyncResult itfAR)
```

Assume you have another Console Application project (`AsyncCallbackDelegate`) making use of the `BinaryOp` delegate. This time, however, you will not poll the delegate to determine whether the `Add()` method has completed. Rather, you will define a static method named `AddComplete()` to receive the notification that the asynchronous invocation is finished. Also, this example uses a class-level static `bool` field, which will be used to keep the primary thread in `Main()` running a task until the secondary thread is finished.

■ **Note** The use of this Boolean variable in this example is, strictly speaking, not thread safe, as there are two different threads that have access to its value. This will be permissible for the current example; however, as a *very* good rule of thumb, you must ensure data that can be shared among multiple threads is locked down. You'll see how to do so later in this chapter.

```
namespace AsyncCallbackDelegate
{
    public delegate int BinaryOp(int x, int y);

    class Program
    {
        private static bool isDone = false;

        static void Main(string[] args)
        {
            Console.WriteLine("***** AsyncCallbackDelegate Example *****");
            Console.WriteLine("Main() invoked on thread {0}.",
                Thread.CurrentThread.ManagedThreadId);

            BinaryOp b = new BinaryOp(Add);
            IAsyncResult iftAR = b.BeginInvoke(10, 10,
                new AsyncCallback(AddComplete), null);
```

```

    // Assume other work is performed here...
    while (!isDone)
    {
        Thread.Sleep(1000);
        Console.WriteLine("Working...");
    }
    Console.ReadLine();
}

static int Add(int x, int y)
{
    Console.WriteLine("Add() invoked on thread {0}.",
        Thread.CurrentThread.ManagedThreadId);
    Thread.Sleep(5000);
    return x + y;
}

static void AddComplete(IAsyncResult itfAR)
{
    Console.WriteLine("AddComplete() invoked on thread {0}.",
        Thread.CurrentThread.ManagedThreadId);
    Console.WriteLine("Your addition is complete");
    isDone = true;
}
}
}

```

Again, the static `AddComplete()` method will be invoked by the `AsyncCallback` delegate when the `Add()` method has completed. If you run this program, you can confirm that the secondary thread is the thread invoking the `AddComplete()` callback.

```

***** AsyncCallbackDelegate Example *****
Main() invoked on thread 1.
Add() invoked on thread 3.
Working....
Working....
Working....
Working....
Working....
AddComplete() invoked on thread 3.
Your addition is complete

```

Like other examples in this chapter, your output might be slightly different. In fact, you might see one final “Working..” printout occur after the addition is complete. This is just a by-product of the forced one-second delay in `Main()`.

The Role of the AsyncResult Class

Currently, the `AddComplete()` method is not printing the actual result of the operation (adding two numbers). The reason is that the target of the `AsyncCallback` delegate (`AddComplete()`, in this example) does not have access to the original `BinaryOp` delegate created in the scope of `Main()` and, therefore, you can't call `EndInvoke()` from within `AddComplete()`!

While you could simply declare the `BinaryOp` variable as a static member variable in the class to allow both methods to access the same object, a more elegant solution is to use the incoming `IAAsyncResult` parameter.

The incoming `IAAsyncResult` parameter passed into the target of the `AsyncCallback` delegate is actually an instance of the `AsyncResult` class (note the lack of an `I` prefix) defined in the `System.Runtime.Remoting.Messaging` namespace. The `AsyncDelegate` property returns a reference to the original asynchronous delegate that was created elsewhere.

Therefore, if you want to obtain a reference to the `BinaryOp` delegate object allocated within `Main()`, simply cast the `System.Object` returned by the `AsyncDelegate` property into type `BinaryOp`. At this point, you can trigger `EndInvoke()` as expected.

```
// Don't forget to import
// System.Runtime.Remoting.Messaging!
static void AddComplete(IAAsyncResult itfAR)
{
    Console.WriteLine("AddComplete() invoked on thread {0}.",
        Thread.CurrentThread.ManagedThreadId);
    Console.WriteLine("Your addition is complete");

    // Now get the result.
    AsyncResult ar = (AsyncResult)itfAR;
    BinaryOp b = (BinaryOp)ar.AsyncDelegate;
    Console.WriteLine("10 + 10 is {0}.", b.EndInvoke(itfAR));
    isDone = true;
}
```

Passing and Receiving Custom State Data

The final aspect of asynchronous delegates you need to address is the final argument to the `BeginInvoke()` method (which has been null up to this point). This parameter allows you to pass additional state information to the callback method from the primary thread. Because this argument is prototyped as a `System.Object`, you can pass in any type of data whatsoever, as long as the callback method knows what to expect. Assume for the sake of demonstration that the primary thread wants to pass in a custom text message to the `AddComplete()` method, like so:

```
static void Main(string[] args)
{
    ...
    IAsyncResult iftAR = b.BeginInvoke(10, 10,
        new AsyncCallback(AddComplete),
        "Main() thanks you for adding these numbers.");
    ...
}
```

To obtain this data within the scope of `AddComplete()`, use the `AsyncState` property of the incoming `IAsyncResult` parameter. Notice that an explicit cast will be required; therefore, the primary and secondary threads must agree on the underlying type returned from `AsyncState`.

```
static void AddComplete(IAsyncResult itfAR)
{
    ...
    // Retrieve the informational object and cast it to string.
    string msg = (string)itfAR.AsyncState;
    Console.WriteLine(msg);
    isDone = true;
}
```

Here is the output of the final iteration:

```
***** AsyncCallbackDelegate Example *****
Main() invoked on thread 1.
Add() invoked on thread 3.
Working...
Working...
Working...
Working...
Working...
AddComplete() invoked on thread 3.
Your addition is complete
10 + 10 is 20.
Main() thanks you for adding these numbers.
```

Now that you understand how a .NET delegate can be used to automatically spin off a secondary thread of execution to handle an asynchronous method invocation, you can turn your attention to directly interacting with threads using the `System.Threading` namespace. Recall that this namespace was the original .NET threading API that shipped since version 1.0.

■ **Source Code** The `AsyncCallbackDelegate` project is located in the [Chapter 19](#) subdirectory.

The System.Threading Namespace

Under the .NET platform, the `System.Threading` namespace provides a number of types that enable the direct construction of multithreaded applications. In addition to providing types that allow you to interact with a particular CLR thread, this namespace defines types that allow access to the CLR-maintained thread pool, a simple (non-GUI-based) `Timer` class, and numerous types used to provide synchronized access to shared resources. [Table 19-1](#) lists some of the important members of this namespace. (Be sure to consult the .NET Framework 4.6 SDK documentation for full details.)

Table 19-1. Core Types of the System.Threading Namespace

| Type | Meaning in Life |
|--------------------------|---|
| Interlocked | This type provides atomic operations for variables that are shared by multiple threads. |
| Monitor | This type provides the synchronization of threading objects using locks and wait/signals. The C# lock keyword uses a Monitor object under the hood. |
| Mutex | This synchronization primitive can be used for synchronization between application domain boundaries. |
| ParameterizedThreadStart | This delegate allows a thread to call methods that take any number of arguments. |
| Semaphore | This type allows you to limit the number of threads that can access a resource, or a particular type of resource, concurrently. |
| Thread | This type represents a thread that executes within the CLR. Using this type, you are able to spawn additional threads in the originating AppDomain. |
| ThreadPool | This type allows you to interact with the CLR-maintained thread pool within a given process. |
| ThreadPriority | This enum represents a thread's priority level (Highest, Normal, etc.). |
| ThreadStart | This delegate is used to specify the method to call for a given thread. Unlike the ParameterizedThreadStart delegate, targets of ThreadStart must always have the same prototype. |
| ThreadState | This enum specifies the valid states a thread may take (Running, Aborted, etc.). |
| Timer | This type provides a mechanism for executing a method at specified intervals. |
| TimerCallback | This delegate type is used in conjunction with Timer types. |

The System.Threading.Thread Class

The most primitive of all types in the System.Threading namespace is Thread. This class represents an object-oriented wrapper around a given path of execution within a particular AppDomain. This type also defines a number of methods (both static and instance level) that allow you to create new threads within the current AppDomain, as well as to suspend, stop, and destroy a particular thread. Consider the list of core static members in Table 19-2.

Table 19-2. Key Static Members of the Thread Type

| Static Member | Meaning in Life |
|------------------------------|---|
| CurrentContext | This read-only property returns the context in which the thread is currently running. |
| CurrentThread | This read-only property returns a reference to the currently running thread. |
| GetDomain() GetDomainID() | These methods return a reference to the current AppDomain or the ID of the domain in which the current thread is running. |
| Sleep() | This method suspends the current thread for a specified time. |

The Thread class also supports several instance-level members, some of which are shown in Table 19-3.

Table 19-3. Select Instance-Level Members of the Thread Type

| Instance-Level Member | Meaning in Life |
|-----------------------|--|
| IsAlive | Returns a Boolean that indicates whether this thread has been started (and has not yet terminated or aborted). |
| IsBackground | Gets or sets a value indicating whether this thread is a “background thread” (more details in just a moment). |
| Name | Allows you to establish a friendly text name of the thread. |
| Priority | Gets or sets the priority of a thread, which may be assigned a value from the ThreadPriority enumeration. |
| ThreadState | Gets the state of this thread, which may be assigned a value from the ThreadState enumeration. |
| Abort() | Instructs the CLR to terminate the thread as soon as possible. |
| Interrupt() | Interrupts (e.g., wakes) the current thread from a suitable wait period. |
| Join() | Blocks the calling thread until the specified thread (the one on which Join() is called) exits. |
| Resume() | Resumes a thread that has been previously suspended. |
| Start() | Instructs the CLR to execute the thread ASAP. |
| Suspend() | Suspends the thread. If the thread is already suspended, a call to Suspend() has no effect. |

■ **Note** Aborting or suspending an active thread is generally considered a bad idea. When you do so, there is a chance (however small) that a thread could “leak” its workload when disturbed or terminated.

Obtaining Statistics About the Current Thread of Execution

Recall that the entry point of an executable assembly (i.e., the Main() method) runs on the primary thread of execution. To illustrate the basic use of the Thread type, assume you have a new Console Application project named ThreadStats. As you know, the static Thread.CurrentThread property retrieves a Thread object that represents the currently executing thread. Once you have obtained the current thread, you are able to print out various statistics, like so:

```
// Be sure to import the System.Threading namespace.
static void Main(string[] args)
{
    Console.WriteLine("***** Primary Thread stats *****\n");

    // Obtain and name the current thread.
    Thread primaryThread = Thread.CurrentThread;
    primaryThread.Name = "ThePrimaryThread";
}
```

```
// Show details of hosting AppDomain/Context.
Console.WriteLine("Name of current AppDomain: {0}",
    Thread.GetDomain().FriendlyName);
Console.WriteLine("ID of current Context: {0}",
    Thread.CurrentContext.ContextID);

// Print out some stats about this thread.
Console.WriteLine("Thread Name: {0}",
    primaryThread.Name);
Console.WriteLine("Has thread started?: {0}",
    primaryThread.IsAlive);
Console.WriteLine("Priority Level: {0}",
    primaryThread.Priority);
Console.WriteLine("Thread State: {0}",
    primaryThread.ThreadState);
Console.ReadLine();
}
```

Here is the current output:

```
***** Primary Thread stats *****
Name of current AppDomain: ThreadStats.exe
ID of current Context: 0
Thread Name: ThePrimaryThread
Has thread started?: True
Priority Level: Normal
Thread State: Running
```

The Name Property

While this code is more or less self-explanatory, do notice that the `Thread` class supports a property called `Name`. If you do not set this value, `Name` will return an empty string. However, once you assign a friendly string moniker to a given `Thread` object, you can greatly simplify your debugging endeavors. If you are using Visual Studio, you may access the `Threads` window during a debugging session (select `Debug` ► `Windows` ► `Threads`). As you can see from [Figure 19-1](#), you can quickly identify the thread you want to diagnose.

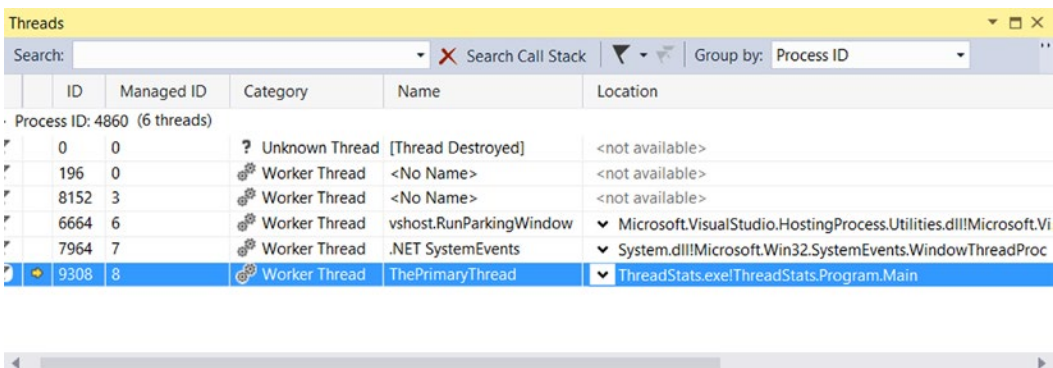

Figure 19-1. Debugging a thread with Visual Studio

The Priority Property

Next, notice that the `Thread` type defines a property named `Priority`. By default, all threads have a priority level of `Normal`. However, you can change this at any point in the thread's lifetime using the `ThreadPriority` property and the related `System.Threading.ThreadPriority` enumeration, like so:

```
public enum ThreadPriority
{
    Lowest,
    BelowNormal,
    Normal, // Default value.
    AboveNormal,
    Highest
}
```

If you were to assign a thread's priority level to a value other than the default (`ThreadPriority.Normal`), understand that you would have no direct control over when the thread scheduler switches between threads. In reality, a thread's priority level offers a hint to the CLR regarding the importance of the thread's activity. Thus, a thread with the value `ThreadPriority.Highest` is not necessarily guaranteed to be given the highest precedence.

Again, if the thread scheduler is preoccupied with a given task (e.g., synchronizing an object, switching threads, or moving threads), the priority level will most likely be altered accordingly. However, all things being equal, the CLR will read these values and instruct the thread scheduler how to best allocate time slices. Threads with an identical thread priority should each receive the same amount of time to perform their work.

In most cases, you will seldom (if ever) need to directly alter a thread's priority level. In theory, it is possible to jack up the priority level on a set of threads, thereby preventing lower-priority threads from executing at their required levels (so use caution).

■ **Source Code** The `ThreadStats` project is in the [Chapter 19](#) subdirectory.

Manually Creating Secondary Threads

When you want to programmatically create additional threads to carry on some unit of work, follow this predictable process when using the types of the `System.Threading` namespace:

1. Create a method to be the entry point for the new thread.
2. Create a new `ParameterizedThreadStart` (or `ThreadStart`) delegate, passing the address of the method defined in step 1 to the constructor.
3. Create a `Thread` object, passing the `ParameterizedThreadStart/ThreadStart` delegate as a constructor argument.
4. Establish any initial thread characteristics (name, priority, etc.).
5. Call the `Thread.Start()` method. This starts the thread at the method referenced by the delegate created in step 2 as soon as possible.

As stated in step 2, you may use two distinct delegate types to “point to” the method that the secondary thread will execute. The `ThreadStart` delegate can point to any method that takes no arguments and returns nothing. This delegate can be helpful when the method is designed to simply run in the background without further interaction.

The obvious limitation of `ThreadStart` is that you are unable to pass in parameters for processing. However, the `ParameterizedThreadStart` delegate type allows a single parameter of type `System.Object`. Given that anything can be represented as a `System.Object`, you can pass in any number of parameters via a custom class or structure. Do note, however, that the `ParameterizedThreadStart` delegate can only point to methods that return `void`.

Working with the ThreadStart Delegate

To illustrate the process of building a multithreaded application (as well as to demonstrate the usefulness of doing so), assume you have a Console Application project (`SimpleMultiThreadApp`) that allows the end user to choose whether the application will perform its duties using the single primary thread or split its workload using two separate threads of execution.

Assuming you have imported the `System.Threading` namespace, your first step is to define a method to perform the work of the (possible) secondary thread. To keep focused on the mechanics of building multithreaded programs, this method will simply print out a sequence of numbers to the console window, pausing for approximately two seconds with each pass. Here is the full definition of the `Printer` class:

```
public class Printer
{
    public void PrintNumbers()
    {
        // Display Thread info.
        Console.WriteLine("-> {0} is executing PrintNumbers()",
            Thread.CurrentThread.Name);

        // Print out numbers.
        Console.Write("Your numbers: ");
        for(int i = 0; i < 10; i++)
        {
            Console.Write("{0}, ", i);
            Thread.Sleep(2000);
        }
        Console.WriteLine();
    }
}
```

Now, within `Main()`, you will first prompt the user to determine whether one or two threads will be used to perform the application’s work. If the user requests a single thread, you will simply invoke the `PrintNumbers()` method within the primary thread. However, if the user specifies two threads, you will create a `ThreadStart` delegate that points to `PrintNumbers()`, pass this delegate object into the constructor of a new `Thread` object, and call `Start()` to inform the CLR this thread is ready for processing.

To begin, set a reference to the `System.Windows.Forms.dll` assembly (and import the `System.Windows.Forms` namespace) and display a message within `Main()` using `MessageBox.Show()` (you'll see the point of doing so after you run the program). Here is the complete implementation of `Main()`:

```
static void Main(string[] args)
{
    Console.WriteLine("***** The Amazing Thread App *****\n");
    Console.Write("Do you want [1] or [2] threads? ");
    string threadCount = Console.ReadLine();

    // Name the current thread.
    Thread primaryThread = Thread.CurrentThread;
    primaryThread.Name = "Primary";

    // Display Thread info.
    Console.WriteLine("-> {0} is executing Main()",
        Thread.CurrentThread.Name);

    // Make worker class.
    Printer p = new Printer();

    switch(threadCount)
    {
        case "2":
            // Now make the thread.
            Thread backgroundThread =
                new Thread(new ThreadStart(p.PrintNumbers));
            backgroundThread.Name = "Secondary";
            backgroundThread.Start();
            break;
        case "1":
            p.PrintNumbers();
            break;
        default:
            Console.WriteLine("I don't know what you want...you get 1 thread.");
            goto case "1";
    }
    // Do some additional work.
    MessageBox.Show("I'm busy!", "Work on main thread...");
    Console.ReadLine();
}
```

Now, if you run this program with a single thread, you will find that the final message box will not display the message until the entire sequence of numbers has printed to the console. As you are explicitly pausing for approximately two seconds after each number is printed, this will result in a less-than-stellar end-user experience. However, if you select two threads, the message box displays instantly, given that a unique `Thread` object is responsible for printing the numbers to the console.

■ **Source Code** The `SimpleMultiThreadApp` project is included in the [Chapter 19](#) subdirectory.

Working with the ParameterizedThreadStart Delegate

Recall that the `ThreadStart` delegate can point only to methods that return `void` and take no arguments. While this might fit the bill in some cases, if you want to pass data to the method executing on the secondary thread, you will need to use the `ParameterizedThreadStart` delegate type. To illustrate, let's re-create the logic of the `AsyncCallbackDelegate` project created earlier in this chapter, this time using the `ParameterizedThreadStart` delegate type.

To begin, create a new Console Application project named `AddWithThreads` and import the `System.Threading` namespace. Now, given that `ParameterizedThreadStart` can point to any method taking a `System.Object` parameter, you will create a custom type containing the numbers to be added, like so:

```
class AddParams
{
    public int a, b;

    public AddParams(int numb1, int numb2)
    {
        a = numb1;
        b = numb2;
    }
}
```

Next, create a static method in the `Program` class that will take an `AddParams` parameter and print the sum of the two numbers involved, as follows:

```
static void Add(object data)
{
    if (data is AddParams)
    {
        Console.WriteLine("ID of thread in Add(): {0}",
            Thread.CurrentThread.ManagedThreadId);

        AddParams ap = (AddParams)data;
        Console.WriteLine("{0} + {1} is {2}",
            ap.a, ap.b, ap.a + ap.b);
    }
}
```

The code within `Main()` is straightforward. Simply use `ParameterizedThreadStart` rather than `ThreadStart`, like so:

```
static void Main(string[] args)
{
    Console.WriteLine("***** Adding with Thread objects *****");
    Console.WriteLine("ID of thread in Main(): {0}",
        Thread.CurrentThread.ManagedThreadId);

    // Make an AddParams object to pass to the secondary thread.
    AddParams ap = new AddParams(10, 10);
    Thread t = new Thread(new ParameterizedThreadStart(Add));
    t.Start(ap);
}
```

```
// Force a wait to let other thread finish.
Thread.Sleep(5);

Console.ReadLine();
}
```

The AutoResetEvent Class

In these first few examples, you have used a few crude ways to inform the primary thread to wait until the secondary thread has completed. During your examination of asynchronous delegates, you used a simple `bool` variable as a toggle; however, this is not a recommended solution, as both threads can access the same point of data, and this can lead to data corruption. A safer but still undesirable alternative is to call `Thread.Sleep()` for a fixed amount of time. The problem here is that you don't want to wait longer than necessary.

One simple, and thread-safe, way to force a thread to wait until another is completed is to use the `AutoResetEvent` class. In the thread that needs to wait (such as a `Main()` method), create an instance of this class and pass in `false` to the constructor to signify you have not yet been notified. Then, at the point at which you are willing to wait, call the `WaitOne()` method. Here is the update to the `Program` class, which will do this very thing using a static-level `AutoResetEvent` member variable:

```
class Program
{
    private static AutoResetEvent waitHandle = new AutoResetEvent(false);

    static void Main(string[] args)
    {
        Console.WriteLine("***** Adding with Thread objects *****");
        Console.WriteLine("ID of thread in Main(): {0}",
            Thread.CurrentThread.ManagedThreadId);
        AddParams ap = new AddParams(10, 10);
        Thread t = new Thread(new ParameterizedThreadStart(Add));
        t.Start(ap);

        // Wait here until you are notified!
        waitHandle.WaitOne();
        Console.WriteLine("Other thread is done!");

        Console.ReadLine();
    }
    ...
}
```

When the other thread is completed with its workload, it will call the `Set()` method on the same instance of the `AutoResetEvent` type.

```
static void Add(object data)
{
    if (data is AddParams)
    {
        Console.WriteLine("ID of thread in Add(): {0}",
            Thread.CurrentThread.ManagedThreadId);
    }
}
```

```

AddParams ap = (AddParams)data;
Console.WriteLine("{0} + {1} is {2}",
    ap.a, ap.b, ap.a + ap.b);

// Tell other thread we are done.
waitHandle.Set();
}
}

```

■ **Source Code** The AddWithThreads project is included in the Chapter 19 subdirectory.

Foreground Threads and Background Threads

Now that you have seen how to programmatically create new threads of execution using the `System.Threading` namespace, let's formalize the distinction between *foreground threads* and *background threads*.

- *Foreground threads* have the ability to prevent the current application from terminating. The CLR will not shut down an application (which is to say, unload the hosting `AppDomain`) until all foreground threads have ended.
- *Background threads* (sometimes called *daemon threads*) are viewed by the CLR as expendable paths of execution that can be ignored at any point in time (even if they are currently laboring over some unit of work). Thus, if all foreground threads have terminated, any and all background threads are automatically killed when the application domain unloads.

It is important to note that foreground and background threads are *not* synonymous with primary and worker threads. By default, every thread you create via the `Thread.Start()` method is automatically a foreground thread. Again, this means that the `AppDomain` will not unload until all threads of execution have completed their units of work. In most cases, this is exactly the behavior you require.

For the sake of argument, however, assume that you want to invoke `Printer.PrintNumbers()` on a secondary thread that should behave as a background thread. Again, this means that the method pointed to by the `Thread` type (via the `ThreadStart` or `ParameterizedThreadStart` delegate) should be able to halt safely as soon as all foreground threads are done with their work. Configuring such a thread is as simple as setting the `IsBackground` property to `true`, like so:

```

static void Main(string[] args)
{
    Console.WriteLine("***** Background Threads *****\n");
    Printer p = new Printer();
    Thread bgroundThread =
        new Thread(new ThreadStart(p.PrintNumbers));

    // This is now a background thread.
    bgroundThread.IsBackground = true;
    bgroundThread.Start();
}

```

Notice that this `Main()` method is *not* making a call to `Console.ReadLine()` to force the console to remain visible until you press the Enter key. Thus, when you run the application, it will shut down immediately because the `Thread` object has been configured as a background thread. Given that the `Main()` method triggers the creation of the primary *foreground* thread, as soon as the logic in `Main()` completes, the `AppDomain` unloads before the secondary thread is able to complete its work.

However, if you comment out the line that sets the `IsBackground` property, you will find that each number prints to the console, as all foreground threads must finish their work before the `AppDomain` is unloaded from the hosting process.

For the most part, configuring a thread to run as a background type can be helpful when the worker thread in question is performing a noncritical task that is no longer needed when the main task of the program is finished. For example, you could build an application that pings an e-mail server every few minutes for new e-mails, updates current weather conditions, or performs some other noncritical task.

The Issue of Concurrency

When you build multithreaded applications, your program needs to ensure that any piece of shared data is protected against the possibility of numerous threads changing its value. Given that all threads in an `AppDomain` have concurrent access to the shared data of the application, imagine what might happen if multiple threads were accessing the same point of data. As the thread scheduler will force threads to suspend their work at random, what if thread A is kicked out of the way before it has fully completed its work? Thread B is now reading unstable data.

To illustrate the problem of concurrency, let's build another Console Application project named `MultiThreadedPrinting`. This application will once again use the `Printer` class created previously, but this time the `PrintNumbers()` method will force the current thread to pause for a randomly generated amount of time.

```
public class Printer
{
    public void PrintNumbers()
    {
        ...
        for (int i = 0; i < 10; i++)
        {
            // Put thread to sleep for a random amount of time.
            Random r = new Random();
            Thread.Sleep(1000 * r.Next(5));
            Console.Write("{0}, ", i);
        }
        Console.WriteLine();
    }
}
```

The `Main()` method is responsible for creating an array of ten (uniquely named) `Thread` objects, each of which is making calls on the *same instance* of the `Printer` object as follows:

```
class Program
{
    static void Main(string[] args)
    {
        Console.WriteLine("*****Synchronizing Threads *****\n");
    }
}
```

```

Printer p = new Printer();

// Make 10 threads that are all pointing to the same
// method on the same object.
Thread[] threads = new Thread[10];
for (int i = 0; i < 10; i++)
{
    threads[i] =
        new Thread(new ThreadStart(p.PrintNumbers));
    threads[i].Name = string.Format("Worker thread #{0}", i);
}
// Now start each one.
foreach (Thread t in threads)
    t.Start();
Console.ReadLine();
}
}

```

Before looking at some test runs, let's recap the problem. The primary thread within this AppDomain begins life by spawning ten secondary worker threads. Each worker thread is told to make calls on the `PrintNumbers()` method on the *same* `Printer` instance. Given that you have taken no precautions to lock down this object's shared resources (the console), there is a good chance that the current thread will be kicked out of the way before the `PrintNumbers()` method is able to print the complete results. Because you don't know exactly when (or if) this might happen, you are bound to get unpredictable results. For example, you might find the output shown here:

*****Synchronizing Threads *****

```

-> Worker thread #1 is executing PrintNumbers()
Your numbers: -> Worker thread #0 is executing PrintNumbers()
-> Worker thread #2 is executing PrintNumbers()
Your numbers: -> Worker thread #3 is executing PrintNumbers()
Your numbers: -> Worker thread #4 is executing PrintNumbers()
Your numbers: -> Worker thread #6 is executing PrintNumbers()
Your numbers: -> Worker thread #7 is executing PrintNumbers()
Your numbers: -> Worker thread #8 is executing PrintNumbers()
Your numbers: -> Worker thread #9 is executing PrintNumbers()
Your numbers: Your numbers: -> Worker thread #5 is executing PrintNumbers()
Your numbers: 0, 0, 0, 0, 1, 0, 0, 1, 1, 1, 2, 2, 2, 3, 3, 3, 2, 1, 0, 0, 4, 3,
4, 1, 2, 4, 5, 5, 5, 6, 6, 6, 2, 7, 7, 7, 3, 4, 0, 8, 4, 5, 1, 5, 8, 8, 9,
2, 6, 1, 0, 9, 1,
6, 2, 7, 9,
2, 1, 7, 8, 3, 2, 3, 3, 9,
8, 4, 4, 5, 9,
4, 3, 5, 5, 6, 3, 6, 7, 4, 7, 6, 8, 7, 4, 8, 5, 5, 6, 6, 8, 7, 7, 9,
8, 9,
8, 9,
9,
9,

```

Now run the application a few more times. Here is another possibility (your results will certainly differ):

```

*****Synchronizing Threads *****
-> Worker thread #0 is executing PrintNumbers()
-> Worker thread #1 is executing PrintNumbers()
-> Worker thread #2 is executing PrintNumbers()
Your numbers: -> Worker thread #4 is executing PrintNumbers()
Your numbers: -> Worker thread #5 is executing PrintNumbers()
Your numbers: Your numbers: -> Worker thread #6 is executing PrintNumbers()
Your numbers: -> Worker thread #7 is executing PrintNumbers()
Your numbers: Your numbers: -> Worker thread #8 is executing PrintNumbers()
Your numbers: -> Worker thread #9 is executing PrintNumbers()
Your numbers: -> Worker thread #3 is executing PrintNumbers()
Your numbers: 0, 0, 0, 0, 0, 0, 0, 0, 0, 0, 1, 1, 1, 1, 1, 1, 1, 1, 1, 1, 2, 2,
2, 2, 2, 2, 2, 2, 2, 2, 3, 3, 3, 3, 3, 3, 3, 3, 3, 3, 4, 4, 4, 4, 4, 4, 4, 4, 4,
4, 5, 5, 5, 5, 5, 5, 5, 5, 5, 5, 6, 6, 6, 6, 6, 6, 6, 6, 6, 6, 7, 7, 7, 7, 7, 7
, 7, 7, 7, 7, 8, 8, 8, 8, 8, 8, 8, 8, 8, 8, 9,
9,
9,
9,
9,
9,
9,
9,
9,
9,
9,
9,

```

■ **Note** If you are unable to generate unpredictable outputs, increase the number of threads from 10 to 100 (for example) or introduce another call to `Thread.Sleep()` within your program. Eventually, you will encounter the concurrency issue.

There are clearly some problems here. As each thread is telling the `Printer` to print the numerical data, the thread scheduler is happily swapping threads in the background. The result is inconsistent output. What you need is a way to programmatically enforce synchronized access to the shared resources. As you would guess, the `System.Threading` namespace provides a number of synchronization-centric types. The C# programming language also provides a particular keyword for the very task of synchronizing shared data in multithreaded applications.

Synchronization Using the C# `lock` Keyword

The first technique you can use to synchronize access to shared resources is the C# `lock` keyword. This keyword allows you to define a scope of statements that must be synchronized between threads. By doing so, incoming threads cannot interrupt the current thread, thus preventing it from finishing its work. The `lock` keyword requires you to specify a *token* (an object reference) that must be acquired by a thread to

enter within the lock scope. When you are attempting to lock down a *private* instance-level method, you can simply pass in a reference to the current type, as follows:

```
private void SomePrivateMethod()
{
    // Use the current object as the thread token.
    lock(this)
    {
        // All code within this scope is thread safe.
    }
}
```

However, if you are locking down a region of code within a *public* member, it is safer (and a best practice) to declare a private object member variable to serve as the lock token, like so:

```
public class Printer
{
    // Lock token.
    private object threadLock = new object();

    public void PrintNumbers()
    {
        // Use the lock token.
        lock (threadLock)
        {
            ...
        }
    }
}
```

In any case, if you examine the `PrintNumbers()` method, you can see that the shared resource the threads are competing to gain access to is the console window. Therefore, if you scope all interactions with the `Console` type within a lock scope, as follows:

```
public void PrintNumbers()
{
    // Use the private object lock token.
    lock (threadLock)
    {
        // Display Thread info.
        Console.WriteLine("-> {0} is executing PrintNumbers()",
            Thread.CurrentThread.Name);
        // Print out numbers.
        Console.Write("Your numbers: ");
        for (int i = 0; i < 10; i++)
        {
            Random r = new Random();
            Thread.Sleep(1000 * r.Next(5));
            Console.Write("{0}, ", i);
        }
        Console.WriteLine();
    }
}
```

you have effectively designed a method that will allow the current thread to complete its task. Once a thread enters into a lock scope, the lock token (in this case, a reference to the current object) is inaccessible by other threads until the lock is released after the lock scope has exited. Thus, if thread A has obtained the lock token, other threads are unable to enter any scope that uses the same lock token until thread A relinquishes the lock token.

■ **Note** If you are attempting to lock down code in a static method, simply declare a private static object member variable to serve as the lock token.

If you now run the application, you can see that each thread has ample opportunity to finish its business.

```
*****Synchronizing Threads *****
-> Worker thread #0 is executing PrintNumbers()
Your numbers: 0, 1, 2, 3, 4, 5, 6, 7, 8, 9,
-> Worker thread #1 is executing PrintNumbers()
Your numbers: 0, 1, 2, 3, 4, 5, 6, 7, 8, 9,
-> Worker thread #3 is executing PrintNumbers()
Your numbers: 0, 1, 2, 3, 4, 5, 6, 7, 8, 9,
-> Worker thread #2 is executing PrintNumbers()
Your numbers: 0, 1, 2, 3, 4, 5, 6, 7, 8, 9,
-> Worker thread #4 is executing PrintNumbers()
Your numbers: 0, 1, 2, 3, 4, 5, 6, 7, 8, 9,
-> Worker thread #5 is executing PrintNumbers()
Your numbers: 0, 1, 2, 3, 4, 5, 6, 7, 8, 9,
-> Worker thread #7 is executing PrintNumbers()
Your numbers: 0, 1, 2, 3, 4, 5, 6, 7, 8, 9,
-> Worker thread #6 is executing PrintNumbers()
Your numbers: 0, 1, 2, 3, 4, 5, 6, 7, 8, 9,
-> Worker thread #8 is executing PrintNumbers()
Your numbers: 0, 1, 2, 3, 4, 5, 6, 7, 8, 9,
-> Worker thread #9 is executing PrintNumbers()
Your numbers: 0, 1, 2, 3, 4, 5, 6, 7, 8, 9,
```

■ **Source Code** The MultiThreadedPrinting project is included in the Chapter 19 subdirectory.

Synchronization Using the System.Threading.Monitor Type

The C# lock statement is really just a shorthand notation for working with the `System.Threading.Monitor` class. Once processed by the C# compiler, a lock scope actually resolves to the following (which you can verify using `ildasm.exe`):

```
public void PrintNumbers()
{
    Monitor.Enter(threadLock);
    try
    {
        // Display Thread info.
        Console.WriteLine("-> {0} is executing PrintNumbers()",
            Thread.CurrentThread.Name);

        // Print out numbers.
        Console.Write("Your numbers: ");
        for (int i = 0; i < 10; i++)
        {
            Random r = new Random();
            Thread.Sleep(1000 * r.Next(5));
            Console.Write("{0}, ", i);
        }
        Console.WriteLine();
    }
    finally
    {
        Monitor.Exit(threadLock);
    }
}
```

First, notice that the `Monitor.Enter()` method is the ultimate recipient of the thread token you specified as the argument to the lock keyword. Next, all code within a lock scope is wrapped within a try block. The corresponding finally clause ensures that the thread token is released (via the `Monitor.Exit()` method), regardless of any possible runtime exception. If you were to modify the `MultiThreadPrinting` program to make direct use of the `Monitor` type (as just shown), you would find the output is identical.

Now, given that the lock keyword seems to require less code than making explicit use of the `System.Threading.Monitor` type, you might wonder about the benefits of using the `Monitor` type directly. The short answer is control. If you use the `Monitor` type, you are able to instruct the active thread to wait for some duration of time (via the static `Monitor.Wait()` method), inform waiting threads when the current thread is completed (via the static `Monitor.Pulse()` and `Monitor.PulseAll()` methods), and so on.

As you would expect, in a great number of cases, the C# lock keyword will fit the bill. However, if you are interested in checking out additional members of the `Monitor` class, consult the .NET Framework 4.6 SDK documentation.

Synchronization Using the System.Threading.Interlocked Type

Although it always is hard to believe until you look at the underlying CIL code, assignments and simple arithmetic operations are *not atomic*. For this reason, the `System.Threading` namespace provides a type that allows you to operate on a single point of data atomically with less overhead than with the `Monitor` type. The `Interlocked` class defines the following key static members shown in Table 19-4.

Table 19-4. Select Static Members of the *System.Threading.Interlocked* Type

| Member | Meaning in Life |
|--------------------------------|--|
| <code>CompareExchange()</code> | Safely tests two values for equality and, if equal, exchanges one of the values with a third |
| <code>Decrement()</code> | Safely decrements a value by 1 |
| <code>Exchange()</code> | Safely swaps two values |
| <code>Increment()</code> | Safely increments a value by 1 |

Although it might not seem like it from the onset, the process of atomically altering a single value is quite common in a multithreaded environment. Assume you have a method named `AddOne()` that increments an integer member variable named `intVal`. Rather than writing synchronization code such as the following:

```
public void AddOne()
{
    lock(myLockToken)
    {
        intVal++;
    }
}
```

you can simplify your code via the static `Interlocked.Increment()` method. Simply pass in the variable to increment by reference. Do note that the `Increment()` method not only adjusts the value of the incoming parameter but also returns the new value.

```
public void AddOne()
{
    int newVal = Interlocked.Increment(ref intVal);
}
```

In addition to `Increment()` and `Decrement()`, the `Interlocked` type allows you to atomically assign numerical and object data. For example, if you want to assign the value of a member variable to the value 83, you can avoid the need to use an explicit lock statement (or explicit `Monitor` logic) and use the `Interlocked.Exchange()` method, like so:

```
public void SafeAssignment()
{
    Interlocked.Exchange(ref myInt, 83);
}
```

Finally, if you want to test two values for equality and change the point of comparison in a thread- safe manner, you are able to leverage the `Interlocked.CompareExchange()` method as follows:

```
public void CompareAndExchange()
{
    // If the value of i is currently 83, change i to 99.
    Interlocked.CompareExchange(ref i, 99, 83);
}
```

Synchronization Using the [Synchronization] Attribute

The final synchronization primitive examined here is the [Synchronization] attribute, which is a member of the `System.Runtime.Remoting.Contexts` namespace. In essence, this class-level attribute effectively locks down *all* instance member code of the object for thread safety. When the CLR allocates objects attributed with [Synchronization], it will place the object within a synchronized context. As you might recall from Chapter 17, objects that should not be removed from a contextual boundary should derive from `ContextBoundObject`. Therefore, if you want to make the `Printer` class type thread safe (without explicitly writing thread-safe code within the class members), you could update the definition as follows:

```
using System.Runtime.Remoting.Contexts;
...

// All methods of Printer are now thread safe!
[Synchronization]
public class Printer : ContextBoundObject
{
    public void PrintNumbers()
    {
        ...
    }
}
```

In some ways, this approach can be seen as the lazy way to write thread-safe code, given that you are not required to dive into the details about which aspects of the type are truly manipulating thread-sensitive data. The major downfall of this approach, however, is that even if a given method is not making use of thread-sensitive data, the CLR will *still* lock invocations to the method. Obviously, this could degrade the overall functionality of the type, so use this technique with care.

Programming with Timer Callbacks

Many applications have the need to call a specific method during regular intervals of time. For example, you might have an application that needs to display the current time on a status bar via a given helper function. As another example, you might want to have your application call a helper function every so often to perform noncritical background tasks such as checking for new e-mail messages. For situations such as these, you can use the `System.Threading.Timer` type in conjunction with a related delegate named `TimerCallback`.

To illustrate, assume you have a Console Application project (`TimerApp`) that will print the current time every second until the user presses a key to terminate the application. The first obvious step is to write the method that will be called by the `Timer` type (be sure to import `System.Threading` into your code file).

```
class Program
{
    static void PrintTime(object state)
    {
        Console.WriteLine("Time is: {0}",
            DateTime.Now.ToLongTimeString());
    }

    static void Main(string[] args)
    {
    }
}
```

Notice the `PrintTime()` method has a single parameter of type `System.Object` and returns `void`. This is not optional, given that the `TimerCallback` delegate can only call methods that match this signature. The value passed into the target of your `TimerCallback` delegate can be any type of object (in the case of the e-mail example, this parameter might represent the name of the Microsoft Exchange server to interact with during the process). Also note that given that this parameter is indeed a `System.Object`, you are able to pass in multiple arguments using a `System.Array` or custom class/structure.

The next step is to configure an instance of the `TimerCallback` delegate and pass it into the `Timer` object. In addition to configuring a `TimerCallback` delegate, the `Timer` constructor allows you to specify the optional parameter information to pass into the delegate target (defined as a `System.Object`), the interval to poll the method, and the amount of time to wait (in milliseconds) before making the first call. Here's an example:

```
static void Main(string[] args)
{
    Console.WriteLine("***** Working with Timer type *****\n");

    // Create the delegate for the Timer type.
    TimerCallback timeCB = new TimerCallback(PrintTime);

    // Establish timer settings.
    Timer t = new Timer(
        timeCB,      // The TimerCallback delegate object.
        null,        // Any info to pass into the called method (null for no info).
        0,           // Amount of time to wait before starting (in milliseconds).
        1000);       // Interval of time between calls (in milliseconds).

    Console.WriteLine("Hit key to terminate...");
    Console.ReadLine();
}
```

In this case, the `PrintTime()` method will be called roughly every second and will pass in no additional information to said method. Here is the output:

```
***** Working with Timer type *****

Hit key to terminate...
Time is: 6:51:48 PM
Time is: 6:51:49 PM
Time is: 6:51:50 PM
Time is: 6:51:51 PM
Time is: 6:51:52 PM
Press any key to continue . . .
```

If you did want to send in some information for use by the delegate target, simply substitute the `null` value of the second constructor parameter with the appropriate information, like so:

```
// Establish timer settings.
Timer t = new Timer(timeCB, "Hello From Main", 0, 1000);
```

You can then obtain the incoming data as follows:

```
static void PrintTime(object state)
{
    Console.WriteLine("Time is: {0}, Param is: {1}",
        DateTime.Now.ToLongTimeString(), state.ToString());
}
```

■ **Source Code** The TimerApp project is included in the Chapter 19 subdirectory.

Understanding the CLR ThreadPool

The next thread-centric topic you will examine in this chapter is the role of the CLR thread pool. When you invoke a method asynchronously using delegate types (via the `BeginInvoke()` method), the CLR does not literally create a new thread. For purposes of efficiency, a delegate's `BeginInvoke()` method leverages a pool of worker threads that is maintained by the runtime. To allow you to interact with this pool of waiting threads, the `System.Threading` namespace provides the `ThreadPool` class type.

If you want to queue a method call for processing by a worker thread in the pool, you can use the `ThreadPool.QueueUserWorkItem()` method. This method has been overloaded to allow you to specify an optional `System.Object` for custom state data in addition to an instance of the `WaitCallback` delegate.

```
public static class ThreadPool
{
    ...
    public static bool QueueUserWorkItem(WaitCallback callBack);
    public static bool QueueUserWorkItem(WaitCallback callBack,
        object state);
}
```

The `WaitCallback` delegate can point to any method that takes a `System.Object` as its sole parameter (which represents the optional state data) and returns nothing. Do note that if you do not provide a `System.Object` when calling `QueueUserWorkItem()`, the CLR automatically passes a null value. To illustrate queuing methods for use by the CLR thread pool, ponder the following program, which uses the `Printer` type once again. In this case, however, you are not manually creating an array of `Thread` objects; rather, you are assigning members of the pool to the `PrintNumbers()` method.

```
class Program
{
    static void Main(string[] args)
    {
        Console.WriteLine("***** Fun with the CLR Thread Pool *****\n");

        Console.WriteLine("Main thread started. ThreadID = {0}",
            Thread.CurrentThread.ManagedThreadId);

        Printer p = new Printer();

        WaitCallback workItem = new WaitCallback(PrintTheNumbers);
    }
}
```



```

// Queue the method ten times.
for (int i = 0; i < 10; i++)
{
    ThreadPool.QueueUserWorkItem(workItem, p);
}
Console.WriteLine("All tasks queued");
Console.ReadLine();
}
static void PrintTheNumbers(object state)
{
    Printer task = (Printer)state;
    task.PrintNumbers();
}
}

```

At this point, you might be wondering if it would be advantageous to use the CLR- maintained thread pool rather than explicitly creating `Thread` objects. Consider these benefits of leveraging the thread pool:

- The thread pool manages threads efficiently by minimizing the number of threads that must be created, started, and stopped.
- By using the thread pool, you can focus on your business problem rather than the application's threading infrastructure.

However, using manual thread management is preferred in some cases. Here's an example:

- If you require foreground threads or must set the thread priority. Pooled threads are *always* background threads with default priority (`ThreadPriority.Normal`).
- If you require a thread with a fixed identity in order to abort it, suspend it, or discover it by name.

■ **Source Code** The `ThreadPoolApp` project is included in the Chapter 19 subdirectory.

That wraps up your investigation of the `System.Threading` namespace. To be sure, understanding the topics presented thus far in the chapter (especially during your examination of concurrency issues) will be extremely valuable when creating a multithreaded application. Given this foundation, you will now turn your attention to a number of new thread-centric topics that are available only with .NET 4.0 and higher. To begin, you will examine the role of an alternative threading model, termed the TPL.

Parallel Programming Using the Task Parallel Library

At this point in the chapter, you have examined two programming techniques (using asynchronous delegates and via the members of `System.Threading`) that allow you to build multithreaded software. Recall that both of these approaches will work under any version of the .NET platform.

Beginning with the release of .NET 4.0, Microsoft introduced a new approach to multithreaded application development using a parallel programming library termed the *Task Parallel Library* (TPL). Using the types of `System.Threading.Tasks`, you can build fine-grained, scalable parallel code without having to work directly with threads or the thread pool.

This is not to say, however, that you will not use the types of `System.Threading` when you use the TPL. In reality, these two threading toolkits can work together quite naturally. This is especially true in that the `System.Threading` namespace still provides a majority of the synchronization primitives you examined previously (`Monitor`, `Interlocked`, and so forth). This being said, you will quite likely find that you will favor working with the TPL rather than the original `System.Threading` namespace, given that the same set of tasks can be performed in a more straightforward manner.

■ **Note** On a related note, be aware that the C# `async` and `await` keywords use various members of the `System.Threading.Tasks` namespace.

The System.Threading.Tasks Namespace

Collectively speaking, the types of `System.Threading.Tasks` are referred to as the *Task Parallel Library*. The TPL will automatically distribute your application's workload across available CPUs dynamically, using the CLR thread pool. The TPL handles the partitioning of the work, thread scheduling, state management, and other low-level details. The end result is that you can maximize the performance of your .NET applications, while being shielded from many of complexities of directly working with threads (see Figure 19-2).

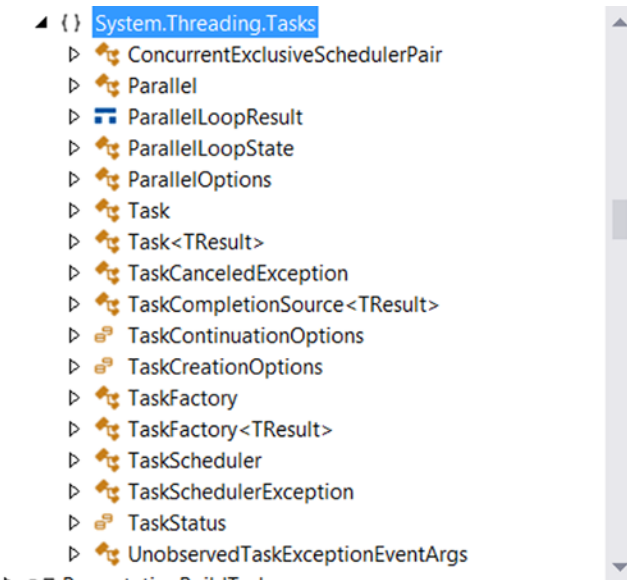

Figure 19-2. Members of the `System.Threading.Tasks` namespace

The Role of the Parallel Class

A key class of the TPL is `System.Threading.Tasks.Parallel`. This class supports a number of methods that allow you to iterate over a collection of data (specifically, an object implementing `IEnumerable<T>`) in a parallel fashion. If you were to look up the `Parallel` class in the .NET Framework 4.6 SDK documentation, you would see that this class supports two primary static methods, `Parallel.For()` and `Parallel.ForEach()`, each of which defines numerous overloaded versions.

These methods allow you to author a body of code statements that will be processed in a parallel manner. In concept, these statements are the same sort of logic you would write in a normal looping construct (via the `for` or `foreach` C# keywords). The benefit is that the `Parallel` class will pluck threads from the thread pool (and manage concurrency) on your behalf.

Both of these methods require you to specify an `IEnumerable-` or `IEnumerable<T>-`compatible container that holds the data you need to process in a parallel manner. The container could be a simple array, a nongeneric collection (such as `ArrayList`), a generic collection (such as `List<T>`), or the results of a LINQ query.

In addition, you will need to use the `System.Func<T>` and `System.Action<T>` delegates to specify the target method that will be called to process the data. You've already encountered the `Func<T>` delegate in Chapter 12, during your investigation of LINQ to Objects. Recall that `Func<T>` represents a method that can have a given return value and a varied number of arguments. The `Action<T>` delegate is similar to `Func<T>`, in that it allows you to point to a method taking some number of parameters. However, `Action<T>` specifies a method that can only return `void`.

While you could call the `Parallel.For()` and `Parallel.ForEach()` methods and pass a strongly typed `Func<T>` or `Action<T>` delegate object, you can simplify your programming by using a fitting C# anonymous method or lambda expression.

Data Parallelism with the Parallel Class

The first way to use the TPL is to perform *data parallelism*. Simply put, this term refers to the task of iterating over an array or collection in a parallel manner using the `Parallel.For()` or `Parallel.ForEach()` method. Assume you need to perform some labor-intensive file I/O operations. Specifically, you need to load a large number of *.jpg files into memory, flip them upside down, and save the modified image data to a new location.

The .NET Framework 4.6 SDK documentation provides a console-based example of this very situation; however, you will see how to perform the same overall task using a graphical user interface so you can examine the use of “anonymous delegates” to allow secondary threads to update the primary user interface thread (aka the UI thread).

■ **Note** When you are building a multithreaded graphical user interface (GUI) application, secondary threads can never directly access user interface controls. The reason is that controls (buttons, text boxes, labels, progress bars, etc.) have thread affinity with the thread that created them. In the following example, I'll illustrate one way to allow secondary threads to access UI items in a thread-safe manner. You'll see a more simplified approach when you examine the C# `async` and `await` keywords.

To illustrate, create a Windows Forms application named `DataParallelismWithForEach`, and use the Solution Explorer to rename `Form1.cs` to `MainForm.cs`. After you do so, import the following namespaces in your primary code file:

```
// Be sure you have these namespaces!
using System.Threading.Tasks;
using System.Threading;
using System.IO;
```

The GUI of the application consists of a multiline `TextBox` and a single `Button` (named `btnProcessImages`). The purpose of the text area is to allow you to enter data while the work is being performed in the background, thus illustrating the nonblocking nature of the parallel task. The `Click` event of this `Button` will eventually use the TPL, but for now, author the following blocking code.

■ **Note** You should update the string passed into the following `Directory.GetFiles()` method call to point to a path on your computer that has some image files (such as a personal folder of family pictures). I've included some sample images (that ship with the Windows operating system) in the `Solution` directory for your convenience.

```
public partial class MainForm : Form
{
    public MainForm()
    {
        InitializeComponent();
    }

    private void btnProcessImages_Click(object sender, EventArgs e)
    {
        ProcessFiles();
    }

    private void ProcessFiles()
    {
        // Load up all *.jpg files, and make a new folder for the modified data.
        string[] files = Directory.GetFiles
            (@":C:\TestPictures", "*.jpg",
            SearchOption.AllDirectories);
        string newDir = @":C:\ModifiedPictures";
        Directory.CreateDirectory(newDir);

        // Process the image data in a blocking manner.
        foreach (string currentFile in files)
        {
            string filename = Path.GetFileName(currentFile);

            using (Bitmap bitmap = new Bitmap(currentFile))
            {
                bitmap.RotateFlip(RotateFlipType.Rotate180FlipNone);
                bitmap.Save(Path.Combine(newDir, filename));

                // Print out the ID of the thread processing the current image.
                this.Text = string.Format("Processing {0} on thread {1}", filename,
                    Thread.CurrentThread.ManagedThreadId);
            }
        }
    }
}
```

Notice that the `ProcessFiles()` method will rotate each *.jpg file under the specified directory, which currently contains 37 files (again, be sure to update the path sent into `Directory.GetFiles()` as necessary). Currently, all the work is happening on the primary thread of the executable. Therefore, if the button is clicked, the program will appear to hang. Furthermore, the caption of the window will also report that the same primary thread is processing the file, as we have only a single thread of execution.

To process the files on as many CPUs as possible, you can rewrite the current `foreach` loop to use `Parallel.ForEach()`. Recall that this method has been overloaded numerous times; however, in the simplest form, you must specify the `IEnumerable<T>`-compatible object that contains the items to process (that would be the files string array) and an `Action<T>` delegate that points to the method that will perform the work.

Here is the relevant update, using the C# lambda operator in place of a literal `Action<T>` delegate object. Notice that you are currently *commenting out* the line of code that displayed the ID of the thread executing the current image file. See the next section to find out the reason why.

```
// Process the image data in a parallel manner!
Parallel.ForEach(files, currentFile =>
{
    string filename = Path.GetFileName(currentFile);

    using (Bitmap bitmap = new Bitmap(currentFile))
    {
        bitmap.RotateFlip(RotateFlipType.Rotate180FlipNone);
        bitmap.Save(Path.Combine(newDir, filename));

        // This code statement is now a problem! See next section.
        // this.Text = string.Format("Processing {0} on thread {1}", filename,
        // Thread.CurrentThread.ManagedThreadId);
    }
}
);
```

Accessing UI Elements on Secondary Threads

You'll notice that I've commented out the previous line of code that updated the caption of the main window with the ID of the currently executing thread. As noted previously, GUI controls have "thread affinity" with the thread that created it. If secondary threads attempt to access a control they did not directly create, you are bound to run into runtime errors when debugging your software. On the flip side, if you were to *run* the application (via `Ctrl+F5`), you might not ever find any problems whatsoever with the original code.

■ **Note** Let me reiterate the previous point: when you debug (F5) a multithreaded application, Visual Studio is often able to catch errors that arise when a secondary thread is "touching" a control created on the primary thread. However, oftentimes when you run (`Ctrl+F5`) the application, the application could appear to run correctly (or it might error straightaway). Until you take precautions (examined next), your application has the potential of raising a runtime error under such circumstances.

One approach that you can use to allow these secondary threads to access the controls in a thread-safe manner is yet another delegate-centric technique, specifically an *anonymous delegate*. The `Control` parent class of the Windows Forms API defines a method named `Invoke()`, which takes a `System.Delegate` as input. You can call this method when you are in a coding context involving secondary threads to provide a thread-safe manner to update the UI of the given control. Now, while you could write all of the required delegate code directly, most developers use anonymous delegates as a simple alternative. Here is the relevant update to content with the previously commented-out code statement:

```
using (Bitmap bitmap = new Bitmap(currentFile))
{
    bitmap.RotateFlip(RotateFlipType.Rotate180FlipNone);
    bitmap.Save(Path.Combine(newDir, filename));

    // Eek! This will not work anymore!
    //this.Text = string.Format("Processing {0} on thread {1}", filename,
    // Thread.CurrentThread.ManagedThreadId);

    // Invoke on the Form object, to allow secondary threads to access controls
    // in a thread-safe manner.
    this.Invoke((Action)delegate
        {
            this.Text = string.Format("Processing {0} on thread {1}", filename,
                Thread.CurrentThread.ManagedThreadId);
        }
    );
}
```

■ **Note** The `this.Invoke()` method is unique to the Windows Forms API. When you are building a WPF application, you would write `this.Dispatcher.Invoke()` for the same purpose.

Now, if you run program, the TPL will indeed distribute the workload to multiple threads from the thread pool, using as many CPUs as possible. However, you will not see the window's caption display the name of each unique thread, and you won't see anything if you type in the text box until all the images have been processed! The reason is that the primary UI thread is still blocked, waiting for all the other threads to finish up their business.

The Task Class

The `Task` class allows you to easily invoke a method on a secondary thread and can be used as a simple alternative to working with asynchronous delegates. Update the `Click` handler of your `Button` control as so:

```
private void btnProcessImages_Click(object sender, EventArgs e)
{
    // Start a new "task" to process the files.
    Task.Factory.StartNew(() =>
    {
        ProcessFiles();
    });
}
```

The `Factory` property of `Task` returns a `TaskFactory` object. When you call its `StartNew()` method, you pass in an `Action<T>` delegate (here, hidden away with a fitting lambda expression) that points to the method to invoke in an asynchronous manner. With this small update, you will now find that the window's title will show which thread from the thread pool is processing a given file, and better yet, the text area is able to receive input, as the UI thread is no longer blocked.

Handling Cancellation Request

One improvement you can make to the current example is to provide a way for the user to stop the processing of the image data, via a second (aptly named) Cancel button. Thankfully, the `Parallel.For()` and `Parallel.ForEach()` methods both support cancellation through the use of *cancellation tokens*. When you invoke methods on `Parallel`, you can pass in a `ParallelOptions` object, which in turn contains a `CancellationTokenSource` object.

First, define the following new private member variable in your Form-derived class of type `CancellationTokenSource` named `cancelToken`:

```
public partial class MainForm : Form
{
    // New Form-level variable.
    private CancellationTokenSource cancelToken =
        new CancellationTokenSource();
    ...
}
```

Now, assuming you have added a new Button (named `btnCancel`) on your designer, handle the Click event and implement the handler as so:

```
private void btnCancel_Click(object sender, EventArgs e)
{
    // This will be used to tell all the worker threads to stop!
    cancelToken.Cancel();
}
```

Now, the real modifications need to occur within the `ProcessFiles()` method. Consider the final implementation:

```
private void ProcessFiles()
{
    // Use ParallelOptions instance to store the CancellationToken.
    ParallelOptions parOpts = new ParallelOptions();
    parOpts.CancellationToken = cancelToken.Token;
    parOpts.MaxDegreeOfParallelism = System.Environment.ProcessorCount;

    // Load up all *.jpg files, and make a new folder for the modified data.
    string[] files = Directory.GetFiles
        (@":C:\Users\Public\Pictures\Sample Pictures", "*.jpg",
         SearchOption.AllDirectories);
    string newDir = @"C:\ModifiedPictures";
    Directory.CreateDirectory(newDir);
}
```

```

try
{
    // Process the image data in a parallel manner!
    Parallel.ForEach(files, parOpts, currentFile =>
    {
        parOpts.CancellationToken.ThrowIfCancellationRequested();

        string filename = Path.GetFileName(currentFile);
        using (Bitmap bitmap = new Bitmap(currentFile))
        {
            bitmap.RotateFlip(RotateFlipType.Rotate180FlipNone);
            bitmap.Save(Path.Combine(newDir, filename));
            this.Invoke((Action)delegate
            {
                this.Text = string.Format("Processing {0} on thread {1}", filename,
                    Thread.CurrentThread.ManagedThreadId);
            }
            );
        }
    }
);
this.Invoke((Action)delegate
{
    this.Text = "Done!";
});
}
catch (OperationCanceledException ex)
{
    this.Invoke((Action)delegate
    {
        this.Text = ex.Message;
    });
}
}

```

Notice that you begin the method by configuring a `ParallelOptions` object, setting the `CancellationToken` property to use the `CancellationTokenSource` token. Also note that when you call the `Parallel.ForEach()` method, you pass in the `ParallelOptions` object as the second parameter.

Within the scope of the looping logic, you make a call to `ThrowIfCancellationRequested()` on the token, which will ensure if the user clicks the Cancel button, all threads will stop, and you will be notified via a runtime exception. When you catch the `OperationCanceledException` error, you will set the text of the main window to the error message.

■ **Source Code** The `DataParallelismWithForEach` project is included in the Chapter 19 subdirectory.

Task Parallelism Using the Parallel Class

In addition to data parallelism, the TPL can also be used to easily fire off any number of asynchronous tasks using the `Parallel.Invoke()` method. This approach is a bit more straightforward than using delegates or members from `System.Threading`; however, if you require more control over the way tasks are executed, you could forgo use of `Parallel.Invoke()` and use the `Task` class directly, as you did in the previous example.

To illustrate task parallelism, create a new Windows Forms application called `MyEBookReader` and be sure the `System.Threading.Tasks` and `System.Net` namespaces are imported. This example is a modification of a useful example in the .NET Framework 4.6 SDK documentation. Here, you will fetch a publically available e-book from Project Gutenberg (www.gutenberg.org) and then perform a set of lengthy tasks in parallel.

The GUI consists of a multiline `TextBox` control (named `txtBook`) and two `Button` controls (`btnDownload` and `btnGetStats`). Once you have designed the UI, handle the `Click` event for each `Button`, and in the form's code file, declare a class-level string variable named `theEBook`. Implement the `Click` handler for the `btnDownload` as so:

```
private void btnDownload_Click(object sender, EventArgs e)
{
    WebClient wc = new WebClient();
    wc.DownloadStringCompleted += (s, eArgs) =>
    {
        theEBook = eArgs.Result;
        txtBook.Text = theEBook;
    };
}

// The Project Gutenberg eBook of A Tale of Two Cities, by Charles Dickens
wc.DownloadStringAsync(new Uri("http://www.gutenberg.org/files/98/98-8.txt"));
}
```

The `WebClient` class is a member of `System.Net`. This class provides a number of methods for sending data to and receiving data from a resource identified by a URI. As it turns out, many of these methods have an asynchronous version, such as `DownloadStringAsync()`. This method will spin up a new thread from the CLR thread pool automatically. When the `WebClient` is done obtaining the data, it will fire the `DownloadStringCompleted` event, which you are handling here using a C# lambda expression. If you were to call the synchronous version of this method (`DownloadString()`), the form would appear unresponsive for quite some time.

The `Click` event handler for the `btnGetStats` `Button` control is implemented to extract the individual words contained in the `theEBook` variable and then pass the string array to a few helper functions for processing as follows:

```
private void btnGetStats_Click(object sender, EventArgs e)
{
    // Get the words from the e-book.
    string[] words = theEBook.Split(new char[]
    { ' ', '\u000A', ',', '.', ';', ':', '-', '?', '/' },
    StringSplitOptions.RemoveEmptyEntries);

    // Now, find the ten most common words.
    string[] tenMostCommon = FindTenMostCommon(words);
}
```

```

// Get the longest word.
string longestWord = FindLongestWord(words);

// Now that all tasks are complete, build a string to show all
// stats in a message box.
StringBuilder bookStats = new StringBuilder("Ten Most Common Words are:\n");
foreach (string s in tenMostCommon)
{
    bookStats.AppendLine(s);
}

bookStats.AppendFormat("Longest word is: {0}", longestWord);
bookStats.AppendLine();
MessageBox.Show(bookStats.ToString(), "Book info");
}

```

The `FindTenMostCommon()` method uses a LINQ query to obtain a list of string objects that occur most often in the string array, while `FindLongestWord()` locates, well, the longest word.

```

private string[] FindTenMostCommon(string[] words)
{
    var frequencyOrder = from word in words
                          where word.Length > 6
                          group word by word into g
                          orderby g.Count() descending
                          select g.Key;
    string[] commonWords = (frequencyOrder.Take(10)).ToArray();
    return commonWords;
}
private string FindLongestWord(string[] words)
{
    return (from w in words orderby w.Length descending select w).FirstOrDefault();
}

```

If you were to run this project, the amount of time to perform all tasks could take a goodly amount of time, based on the CPU count of your machine and overall processor speed. Eventually, you should see the output shown in Figure 19-3.

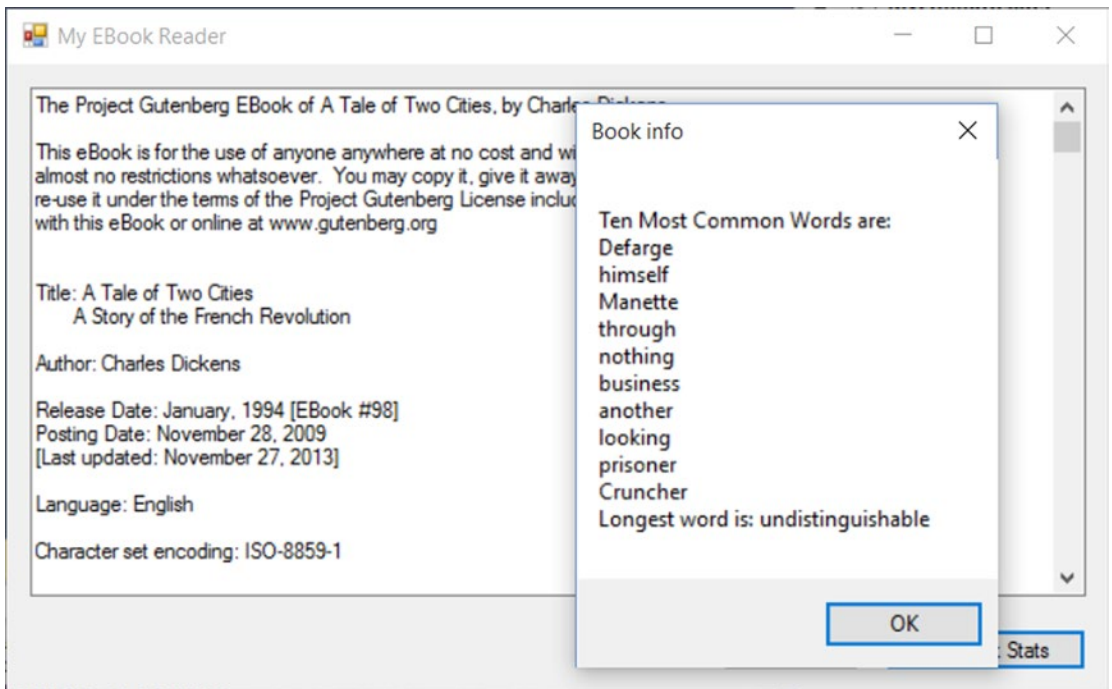

Figure 19-3. Stats about the downloaded e-book

You can help ensure that your application uses all available CPUs on the host machine by invoking the `FindTenMostCommon()` and `FindLongestWord()` methods in parallel. To do so, modify your `btnGetStats_Click()` method as so:

```
private void btnGetStats_Click(object sender, EventArgs e)
{
    // Get the words from the e-book.
    string[] words = theEBook.Split(
        new char[] { ' ', '\u000A', ',', '.', ';', ':', '-', '?', '/' },
        StringSplitOptions.RemoveEmptyEntries);
    string[] tenMostCommon = null;
    string longestWord = string.Empty;

    Parallel.Invoke(
        () =>
        {
            // Now, find the ten most common words.
            tenMostCommon = FindTenMostCommon(words);
        },
        () =>
        {
            // Get the longest word.
            longestWord = FindLongestWord(words);
        });
};
```

```
// Now that all tasks are complete, build a string to show all
// stats in a message box.
...
}
```

The `Parallel.Invoke()` method expects a parameter array of `Action<>` delegates, which you have supplied indirectly using lambda expressions. Again, while the output is identical, the benefit is that the TPL will now use all possible processors on the machine to invoke each method in parallel if possible.

■ **Source Code** The `MyEBookReader` project is included in the [Chapter 19](#) subdirectory.

Parallel LINQ Queries (PLINQ)

To wrap up your look at the TPL, be aware that there is another way you can incorporate parallel tasks into your .NET applications. If you choose, you can use a set of extension methods, which allow you to construct a LINQ query that will perform its workload in parallel (if possible). Fittingly, LINQ queries that are designed to run in parallel are termed *PLINQ queries*.

Like parallel code authored using the `Parallel` class, PLINQ has the option of ignoring your request to process the collection in parallel if need be. The PLINQ framework has been optimized in numerous ways, which includes determining whether a query would, in fact, perform faster in a synchronous manner.

At runtime, PLINQ analyzes the overall structure of the query, and if the query is likely to benefit from parallelization, it will run concurrently. However, if parallelizing a query would hurt performance, PLINQ just runs the query sequentially. If PLINQ has a choice between a potentially expensive parallel algorithm or an inexpensive sequential algorithm, it chooses the sequential algorithm by default.

The necessary extension methods are found within the `ParallelEnumerable` class of the `System.Linq` namespace. [Table 19-5](#) documents some useful PLINQ extensions.

Table 19-5. *Select Members of the `ParallelEnumerable` Class*

| Member | Meaning in Life |
|--|--|
| <code>AsParallel()</code> | Specifies that the rest of the query should be parallelized, if possible. |
| <code>WithCancellation()</code> | Specifies that PLINQ should periodically monitor the state of the provided cancellation token and cancel execution if it is requested. |
| <code>WithDegreeOfParallelism()</code> | Specifies the maximum number of processors that PLINQ should use to parallelize the query. |
| <code>ForAll()</code> | Enables results to be processed in parallel without first merging back to the consumer thread, as would be the case when enumerating a LINQ result using the <code>foreach</code> keyword. |

To see PLINQ in action, create a final Windows Forms application named `PLINQDataProcessingWithCancellation` and import the `System.Threading` namespace. This simple form will need only two `Button` controls named `btnExecute` and `btnCancel`. Then the `Execute` button is clicked, and you will fire off a new `Task`, which executes a LINQ query that investigates a large array of integers, looking for only the items where `x % 3 == 0` is true. Here is a *nonparallel* version of the query:

```
public partial class MainForm : Form
{
    ...
    private void btnExecute_Click(object sender, EventArgs e)
    {
        // Start a new "task" to process the ints.
        Task.Factory.StartNew(() =>
        {
            ProcessIntData();
        });
    }

    private void ProcessIntData()
    {
        // Get a very large array of integers.
        int[] source = Enumerable.Range(1, 10000000).ToArray();

        // Find the numbers where num % 3 == 0 is true, returned
        // in descending order.
        int[] modThreeIsZero = (from num in source where num % 3 == 0
                               orderby num descending select num).ToArray();

        MessageBox.Show(string.Format("Found {0} numbers that match query!",
                                     modThreeIsZero.Count()));
    }
}
```

Opting in to a PLINQ Query

If you want to inform the TPL to execute this query in parallel (if possible), you will want to use the `AsParallel()` extension method as so:

```
int[] modThreeIsZero = (from num in source.AsParallel() where num % 3 == 0
                       orderby num descending select num).ToArray();
```

Notice how the overall format of the LINQ query is identical to what you saw in previous chapters. However, by including a call to `AsParallel()`, the TPL will attempt to pass the workload off to an available CPU.

Cancelling a PLINQ Query

It is also possible to use a `CancellationTokenSource` object to inform a PLINQ query to stop processing under the correct conditions (typically because of user intervention). Declare a form-level `CancellationTokenSource` object named `cancelToken` and implement the `Click` handler of the `btnCancel` to call the `Cancel()` method on this object. Here is the relevant code update:

```
public partial class MainForm : Form
{
    private CancellationTokenSource cancelToken = new CancellationTokenSource();

    private void btnCancel_Click(object sender, EventArgs e)
    {
        cancelToken.Cancel();
    }
    ...
}
```

Now, inform the PLINQ query that it should be on the lookout for an incoming cancellation request by chaining on the `WithCancellation()` extension method and passing in the token. In addition, you will want to wrap this PLINQ query in a proper `try/catch` scope and deal with the possible exception. Here is the final version of the `ProcessIntData()` method:

```
private void ProcessIntData()
{
    // Get a very large array of integers.
    int[] source = Enumerable.Range(1, 10000000).ToArray();

    // Find the numbers where num % 3 == 0 is true, returned
    // in descending order.
    int[] modThreeIsZero = null;
    try
    {
        modThreeIsZero = (from num in
            source.AsParallel().WithCancellation(cancelToken.Token)
            where num % 3 == 0 orderby num descending
            select num).ToArray();
        MessageBox.Show(string.Format("Found {0} numbers that match query!",
            modThreeIsZero.Count()));
    }
    catch (OperationCanceledException ex)
    {
        this.Invoke((Action)delegate
        {
            this.Text = ex.Message;
        });
    }
}
```

■ **Source Code** The `PLINQDataProcessingWithCancellation` project is in the [Chapter 19](#) subdirectory.

Asynchronous Calls with the `async` Keyword

I have covered a lot of terse material in this (rather lengthy) chapter. To be sure, building, debugging, and understanding complex multithreaded applications is a challenge in any framework. While the TPL, PLINQ, and the delegate type can simplify matters to some extent (especially when compared to other platforms and languages), developers are still required to be fairly savvy with the ins and outs of various advanced techniques.

Since the release of .NET 4.5, the C# programming language (and for that matter, the VB programming language) has been updated with two new keywords that further simplify the process of authoring asynchronous code. In contrast to all the examples in this chapter, when you use the new `async` and `await` keywords, the compiler will generate a good deal of threading code on your behalf, using numerous members of the `System.Threading` and `System.Threading.Tasks` namespaces.

A First Look at the C# `async` and `await` Keywords

The `async` keyword of C# is used to qualify that a method, lambda expression, or anonymous method should be called in an asynchronous manner *automatically*. Yes, it's true. Simply by marking a method with the `async` modifier, the CLR will create a new thread of execution to handle the task at hand. Furthermore, when you are calling an `async` method, the `await` keyword will *automatically* pause the current thread from any further activity until the task is complete, leaving the calling thread free to continue on its merry way.

To illustrate, create a new Windows Forms application named `FunWithCSharpAsync` and import the `System.Threading` namespace into the initial form's primary code file (I renamed my initial form to be `MainForm`). After you have done so, place a single `Button` control (named `btnCallMethod`) and a single `TextBox` control (named `txtInput`) on the designer surface, and configure any basic UI properties (colors, fonts, text) you want. Now, handle the `Click` event of the `Button` control, and within the event handler, call a private helper method named `DoWork()`, which forces the calling thread to wait for ten seconds. Here is the story thus far:

```
public partial class MainForm : Form
{
    public MainForm()
    {
        InitializeComponent();
    }

    private void btnCallMethod_Click(object sender, EventArgs e)
    {
        this.Text = DoWork();
    }

    private string DoWork()
    {
        Thread.Sleep(10000);
        return "Done with work!";
    }
}
```

Now, given your work in this chapter, you know that if you were to run the program and click this button, you would need to wait 10 seconds before the text box control could receive keyboard input. Furthermore, you will not see the title of the main window update with the message "Done with work!" for ten seconds as well.

If you were to use any of the previous techniques shown in this chapter to make your program more responsive, you would have a good deal of work ahead of you. However, since .NET 4.5, you can author the following C# code base:

```
public partial class MainForm : Form
{
    public MainForm()
    {
        InitializeComponent();
    }

    private async void btnCallMethod_Click(object sender, EventArgs e)
    {
        this.Text = await DoWork();
    }

    // See below for code walkthrough...
    private Task<string> DoWork()
    {
        return Task.Run(() =>
        {
            Thread.Sleep(10000);
            return "Done with work!";
        });
    }
}
```

First, notice that the button's Click event handler has been marked with the `async` keyword. This marks the method as a member to be called in a nonblocking manner. Also notice that the implementation of the event handler uses the `await` keyword *before* naming the method that will be called. This is important: if you decorate a method with the `async` keyword but do not have at least one internal `await`-centric method call, you have essentially built a blocking, synchronous method call (in fact, you will be given a compiler warning to this effect).

Now, notice that you are required to use the `Task` class from the `System.Threading.Tasks` namespace to refactor our `DoWork()` method to work as expected. Basically, rather than returning a specific return value straightaway (a `string` object in the current example), you return a `Task<T>` object, where the generic type parameter `T` is the underlying, actual return value (with me so far?).

The implementation of `DoWork()` now directly returns a `Task<T>` object, which is the return value of `Task.Run()`. The `Run()` method takes a `Func<>` or `Action<>` delegate, and as you know by this point in the text, you can simplify your life by using a lambda expression. Basically, your new version of `DoWork()` is essentially saying the following:

When you call me, I will run a new task. This task will cause the calling thread to sleep for 10 seconds, and when it is done, it gives me a string return value. I'll put this string in a new `Task<string>` object and return it to the caller.

Having translated this new implementation of `DoWork()` into more natural (poetic) language, you gain some insight into the real role of the `await` token. This keyword will always modify a method that returns a `Task` object. When the flow of logic reaches the `await` token, the calling thread is suspended until the call completes. If you were to run this version of the application, you would find that you could click the button and happily type within the text area immediately. Ten seconds later, your window's title would update with the completed message notification.

Naming Conventions for Async Methods

Now, let's say that the new version of `DoWork()` is exactly as currently shown; however, the button's `Click` event handler has been implemented as so:

```
private async void btnCallMethod_Click(object sender, EventArgs e)
{
    // Oops! No await keyword here!
    this.Text = DoWork();
}
```

Notice you did indeed mark the method with the `async` keyword, but you neglected to use the `await` keyword as a decorator before the `DoWork()` method call. At this point, you will have compiler errors, as the return value of `DoWork()` is a `Task` object, which you are attempting to assign directly to the `Text` property (which takes a `string` data type). Remember, the `await` token is in charge of extracting out the internal return value contained in the `Task` object. Since you have not used this token, you have a type mismatch.

■ **Note** An “awaitable” method is simply a method that returns a `Task<T>`.

Given that methods that return `Task` objects can now be called in a nonblocking manner via the `async` and `await` tokens, Microsoft recommends (as a best practice) that any method returning a `Task` be marked with an `Async` suffix. In this way, developers who know the naming convention receive a visual reminder that the `await` keyword is required, if they intend to invoke the method within an asynchronous context.

■ **Note** Event handlers for GUI controls (such as your button `Click` handler) that use the `async` /`await` keywords do not follow this naming convention (by convention—pardon the redundancy!).

Furthermore, the `DoWork()` method could also be decorated with the `async` and `await` tokens (although this is not strictly required for the current example). Given these points, here is the final update to the current example, which conforms to the recommending naming conventions:

```
public partial class MainForm : Form
{
    public MainForm()
    {
        InitializeComponent();
    }
    private async void btnCallMethod_Click(object sender, EventArgs e)
    {
        this.Text = await DoWorkAsync();
    }
}
```

```
private async Task<string> DoWorkAsync()
{
    return await Task.Run(() =>
    {
        Thread.Sleep(10000);
        return "Done with work!";
    });
}
```

Async Methods Returning Void

Currently, your `DoWork()` method is returning a `Task`, which contains “real data” for the caller that will be obtained transparently via the `await` keyword. However, what if you want to build an asynchronous method that returns `void`? In this case, you use the nongeneric `Task` class and omit any return statement, like so:

```
private async Task MethodReturningVoidAsync()
{
    await Task.Run(() => { /* Do some work here... */
        Thread.Sleep(4000);
    });
}
```

The caller of this method, such as a second button `Click` event handler, would then use the `await` and `async` keywords as so:

```
private async void btnVoidMethodCall_Click(object sender, EventArgs e)
{
    await MethodReturningVoidAsync();
    MessageBox.Show("Done!");
}
```

Async Methods with Multiple Awaits

It is completely permissible for a single `async` method to have multiple `await` contexts within its implementation. Assume your application now has a third button `Click` event handler that has been marked with the `async` keyword. In the previous parts of this example, the `Click` handlers purposely called some external method that runs the underlying `Task`; however, you could inline this logic via a set of lambda expressions as so:

```
private async void btnMutliAwaits_Click(object sender, EventArgs e)
{
    await Task.Run(() => { Thread.Sleep(2000); });
    MessageBox.Show("Done with first task!");

    await Task.Run(() => { Thread.Sleep(2000); });
    MessageBox.Show("Done with second task!");

    await Task.Run(() => { Thread.Sleep(2000); });
    MessageBox.Show("Done with third task!");
}
```

Again, here each task is not doing much more than suspending the current thread for a spell; however, any unit of work could be represented by these tasks (calling a web service, reading a database, or what have you). In any case, let's summarize the key points of this example, as follows:

- Methods (as well as lambda expressions or anonymous methods) can be marked with the `async` keyword to enable the method to do work in a nonblocking manner.
- Methods (as well as lambda expressions or anonymous methods) marked with the `async` keyword will run in a *blocking* manner until the `await` keyword is encountered.
- A single `async` method can have multiple `await` contexts.
- When the `await` expression is encountered, the calling thread is suspended until the awaited task is complete. In the meantime, control is returned to the caller of the method.
- The `await` keyword will hide the returned `Task` object from view, appearing to directly return the underlying return value. Methods with no return value simply return `void`.
- As a naming convention, methods that are to be called asynchronously should be marked with the `Async` suffix.

■ **Source Code** The `FunWithCSharpAsync` project is in the [Chapter 19](#) subdirectory.

Retrofitting the `AddWithThreads` Example Using `Async/Await`

Much earlier in this chapter, you built an example named `AddWithThreads` using the original threading API of the .NET platform, `System.Threading`. Now, let's retrofit this example to use the C# `async` and `await` keywords to showcase just how much cleaner the application logic can become. First, let me remind you of the basics of how the `AddWithThreads` project worked initially.

- You created a custom class named `AddParams`, which represented the data to be summed.
- You used the `Thread` class and `ParameterizedThreadStart` delegate to point to an `Add()` method receiving an `AddParams` object.
- You used the `AutoResetEvent` class to ensure the calling thread waited for the secondary thread to complete.

All in all, it was a good deal of effort to simply compute the addition of two numbers on a secondary thread of execution! Here is the same project, now refactored using the techniques under examination (I did not reprint the `AddParams` class here, but recall it simply had two fields, `a` and `b`, to represent the data to sum):

```
class Program
{
    static void Main(string[] args)
    {
        AddAsync();
        Console.ReadLine();
    }
}
```

```

private static async Task AddAsync()
{
    Console.WriteLine("***** Adding with Thread objects *****");
    Console.WriteLine("ID of thread in Main(): {0}",
        Thread.CurrentThread.ManagedThreadId);

    AddParams ap = new AddParams(10, 10);
    await Sum(ap);

    Console.WriteLine("Other thread is done!");
}

static async Task Sum(object data)
{
    await Task.Run(() =>
    {
        if (data is AddParams)
        {
            Console.WriteLine("ID of thread in Add(): {0}",
                Thread.CurrentThread.ManagedThreadId);

            AddParams ap = (AddParams)data;
            Console.WriteLine("{0} + {1} is {2}",
                ap.a, ap.b, ap.a + ap.b);
        }
    });
}
}

```

The first thing I'd like to point out is that the code that was initially in `Main()` has been moved into a new method named `AddAsync()`. The reason was not only to conform to the expected naming convention, but this brings up an important point.

■ **Note** The `Main()` method of an executable cannot be marked with the `async` keyword.

Note that `AddAsync()` is marked with the `async` token and has defined an `await` context. As well, the `Sum()` method is spinning off a new `Task` to perform the unit of work. In any case, lo and behold, when you run the program, you find that 10 plus 10 is still indeed 20. Note, however, that you do have two unique thread IDs.

```

***** Adding with Thread objects *****
ID of thread in Main(): 1
ID of thread in Add(): 3
10 + 10 is 20
Other thread is done!

```

■ **Source Code** The `AddWithThreadsAsync` project is in the Chapter 19 subdirectory.

So, as you can see, the `async` and `await` keywords can simplify the process of invoking methods on a secondary thread of execution. While you have worked through only a few examples of what can be done with this aspect of the C# language, you are in a good position for further exploration.

Summary

This chapter began by examining how .NET delegate types can be configured to execute a method in an asynchronous manner. As you have seen, the `BeginInvoke()` and `EndInvoke()` methods allow you to indirectly manipulate a secondary thread with minimum fuss and bother. During this discussion, you were also introduced to the `IAsyncResult` interface and `AsyncResult` class type. As you learned, these types provide various ways to synchronize the calling thread and obtain possible method return values.

The next part of this chapter examined the role of the `System.Threading` namespace. As you learned, when an application creates additional threads of execution, the result is that the program in question is able to carry out numerous tasks at (what appears to be) the same time. You also examined several manners in which you can protect thread-sensitive blocks of code to ensure that shared resources do not become unusable units of bogus data.

This chapter then examined some new models for working with multithreaded development introduced with .NET 4.0, specifically the Task Parallel Library and PLINQ. I wrapped things up by covering the role of the `async` and `await` keywords. As you have seen, these keywords are using many types of the TPL framework in the background; however, the compiler does a majority of the work to create the complex threading and synchronization code on your behalf.

CHAPTER 20



File I/O and Object Serialization

When you create desktop applications, the ability to save information between user sessions is commonplace. This chapter examines a number of I/O-related topics as seen through the eyes of the .NET Framework. The first order of business is to explore the core types defined in the `System.IO` namespace and learn how to modify a machine's directory and file structure programmatically. The next task is to explore various ways to read from and write to character-based, binary-based, string-based, and memory-based data stores.

After you learn how to manipulate files and directories using the core I/O types, you will examine the related topic of *object serialization*. You can use object serialization to persist and retrieve the state of an object to (or from) any `System.IO.Stream`-derived type. The ability to serialize objects is critical when you want to copy an object to a remote machine using various remoting technologies such as Windows Communication Foundation. However, serialization is quite useful in its own right and will likely play a role in many of your .NET applications (distributed or not).

■ **Note** To ensure you can run each of the examples in this chapter, start Visual Studio with administrative rights (just right-click the VS icon and select Run as Administrator). If you do not do so, you may encounter runtime security exceptions when accessing the computer file system.

Exploring the System.IO Namespace

In the framework of .NET, the `System.IO` namespace is the region of the base class libraries devoted to file-based (and memory-based) input and output (I/O) services. Like any namespace, `System.IO` defines a set of classes, interfaces, enumerations, structures, and delegates, most of which you can find in `mscorlib.dll`. In addition to the types contained within `mscorlib.dll`, the `System.dll` assembly defines additional members of the `System.IO` namespace. Note that all Visual Studio projects automatically set a reference to both assemblies.

Many of the types within the `System.IO` namespace focus on the programmatic manipulation of physical directories and files. However, additional types provide support to read data from and write data to string buffers, as well as raw memory locations. Table 20-1 outlines the core (nonabstract) classes, providing a road map of the functionality in `System.IO`.

Table 20-1. Key Members of the *System.IO* Namespace

| Nonabstract I/O Class Type | Meaning in Life |
|------------------------------|---|
| BinaryReader BinaryWriter | These classes allow you to store and retrieve primitive data types (integers, Booleans, strings, and whatnot) as a binary value. |
| BufferedStream | This class provides temporary storage for a stream of bytes that you can commit to storage at a later time. |
| Directory DirectoryInfo | You use these classes to manipulate a machine's directory structure. The <code>Directory</code> type exposes functionality using <i>static members</i> , while the <code>DirectoryInfo</code> type exposes similar functionality from a valid <i>object reference</i> . |
| DriveInfo | This class provides detailed information regarding the drives that a given machine uses. |
| File FileInfo | You use these classes to manipulate a machine's set of files. The <code>File</code> type exposes functionality using <i>static members</i> , while the <code>FileInfo</code> type exposes similar functionality from a valid <i>object reference</i> . |
| FileStream | This class gives you random file access (e.g., seeking capabilities) with data represented as a stream of bytes. |
| FileSystemWatcher | This class allows you to monitor the modification of external files in a specified directory. |
| MemoryStream | This class provides random access to streamed data stored in memory rather than in a physical file. |
| Path | This class performs operations on <code>System.String</code> types that contain file or directory path information in a platform-neutral manner. |
| StreamWriter StreamReader | You use these classes to store (and retrieve) textual information to (or from) a file. These types do not support random file access. |
| StringWriter StringReader | Like the <code>StreamReader/StreamWriter</code> classes, these classes also work with textual information. However, the underlying storage is a string buffer rather than a physical file. |

In addition to these concrete class types, `System.IO` defines a number of enumerations, as well as a set of abstract classes (e.g., `Stream`, `TextReader`, and `TextWriter`), that define a shared polymorphic interface to all descendants. You will read about many of these types in this chapter.

The Directory(Info) and File(Info) Types

`System.IO` provides four classes that allow you to manipulate individual files, as well as interact with a machine's directory structure. The first two types, `Directory` and `File`, expose creation, deletion, copying, and moving operations using various static members. The closely related `FileInfo` and `DirectoryInfo` types expose similar functionality as instance-level methods (therefore, you must allocate them with the new keyword). In Figure 20-1, the `Directory` and `File` classes directly extend `System.Object`, while `DirectoryInfo` and `FileInfo` derive from the abstract `FileSystemInfo` type.

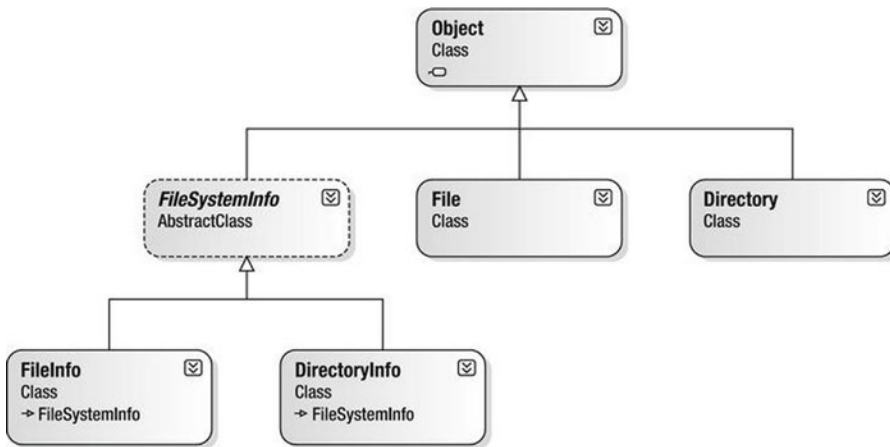

Figure 20-1. The File- and Directory-centric types

FileInfo and DirectoryInfo typically serve as better choices for obtaining full details of a file or directory (e.g., time created or read/write capabilities) because their members tend to return strongly typed objects. In contrast, the Directory and File class members tend to return simple string values rather than strongly typed objects. This is only a guideline, however; in many cases, you can get the same work done using File/FileInfo or Directory/DirectoryInfo.

The Abstract FileSystemInfo Base Class

The DirectoryInfo and FileInfo types receive many behaviors from the abstract FileSystemInfo base class. For the most part, you use the members of the FileSystemInfo class to discover general characteristics (such as time of creation, various attributes, and so forth) about a given file or directory. Table 20-2 lists some core properties of interest.

Table 20-2. FileSystemInfo Properties

| Property | Meaning in Life |
|----------------|--|
| Attributes | Gets or sets the attributes associated with the current file that are represented by the FileAttributes enumeration (e.g., is the file or directory read-only, encrypted, hidden, or compressed?). |
| CreationTime | Gets or sets the time of creation for the current file or directory. |
| Exists | Determines whether a given file or directory exists. |
| Extension | Retrieves a file's extension. |
| FullName | Gets the full path of the directory or file. |
| LastAccessTime | Gets or sets the time the current file or directory was last accessed. |
| LastWriteTime | Gets or sets the time when the current file or directory was last written to. |
| Name | Obtains the name of the current file or directory. |

`FileSystemInfo` also defines the `Delete()` method. This is implemented by derived types to delete a given file or directory from the hard drive. Also, you can call `Refresh()` prior to obtaining attribute information to ensure that the statistics regarding the current file (or directory) are not outdated.

Working with the `DirectoryInfo` Type

The first creatable I/O-centric type you will examine is the `DirectoryInfo` class. This class contains a set of members used for creating, moving, deleting, and enumerating over directories and subdirectories. In addition to the functionality provided by its base class (`FileSystemInfo`), `DirectoryInfo` offers the key members detailed in Table 20-3.

Table 20-3. Key Members of the `DirectoryInfo` Type

| Member | Meaning in Life |
|-----------------------------------|---|
| <code>Create()</code> | Create a directory (or set of subdirectories) when given a path name |
| <code>CreateSubdirectory()</code> | |
| <code>Delete()</code> | Deletes a directory and all its contents |
| <code>GetDirectories()</code> | Returns an array of <code>DirectoryInfo</code> objects that represent all subdirectories in the current directory |
| <code>GetFiles()</code> | Retrieves an array of <code>FileInfo</code> objects that represent a set of files in the given directory |
| <code>MoveTo()</code> | Moves a directory and its contents to a new path |
| <code>Parent</code> | Retrieves the parent directory of this directory |
| <code>Root</code> | Gets the root portion of a path |

You begin working with the `DirectoryInfo` type by specifying a particular directory path as a constructor parameter. Use the dot (`.`) notation if you want to obtain access to the current working directory (the directory of the executing application). Here are some examples:

```
// Bind to the current working directory.
DirectoryInfo dir1 = new DirectoryInfo(".");
// Bind to C:\Windows,
// using a verbatim string.
DirectoryInfo dir2 = new DirectoryInfo(@"C:\Windows");
```

In the second example, you assume that the path passed into the constructor (`C:\Windows`) already exists on the physical machine. However, if you attempt to interact with a nonexistent directory, a `System.IO.DirectoryNotFoundException` is thrown. Thus, if you specify a directory that is not yet created, you need to call the `Create()` method before proceeding, like so:

```
// Bind to a nonexistent directory, then create it.
DirectoryInfo dir3 = new DirectoryInfo(@"C:\MyCode\Testing");
dir3.Create();
```

After you create a `DirectoryInfo` object, you can investigate the underlying directory contents using any of the properties inherited from `FileSystemInfo`. To see this in action, create a new Console Application project named `DirectoryApp` and update your C# file to import `System.IO`. Update your `Program` class with the following new static method that creates a new `DirectoryInfo` object mapped to `C:\Windows` (adjust your path if need be), which displays a number of interesting statistics:

```
class Program
{
    static void Main(string[] args)
    {
        Console.WriteLine("***** Fun with Directory(Info) *****\n");
        ShowWindowsDirectoryInfo();
        Console.ReadLine();
    }

    static void ShowWindowsDirectoryInfo()
    {
        // Dump directory information.
        DirectoryInfo dir = new DirectoryInfo(@"C:\Windows");
        Console.WriteLine("***** Directory Info *****");
        Console.WriteLine("FullName: {0}", dir.FullName);
        Console.WriteLine("Name: {0}", dir.Name);
        Console.WriteLine("Parent: {0}", dir.Parent);
        Console.WriteLine("Creation: {0}", dir.CreationTime);
        Console.WriteLine("Attributes: {0}", dir.Attributes);
        Console.WriteLine("Root: {0}", dir.Root);
        Console.WriteLine("*****\n");
    }
}
```

While your output might differ, you should see something similar to the following:

```
***** Fun with Directory(Info) *****

***** Directory Info *****
FullName: C:\Windows
Name: Windows
Parent:
Creation: 10/10/2015 10:22:32 PM
Attributes: Directory
Root: C:\
*****
```

Enumerating Files with the `DirectoryInfo` Type

In addition to obtaining basic details of an existing directory, you can extend the current example to use some methods of the `DirectoryInfo` type. First, you can leverage the `GetFiles()` method to obtain information about all `*.jpg` files located in the `C:\Windows\Web\Wallpaper` directory.

■ **Note** If your machine does not have a C:\Windows\Web\Wallpaper directory, retrofit this code to read files of a directory on your machine (e.g., to read all *.bmp files from the C:\Windows directory).

The `GetFiles()` method returns an array of `FileInfo` objects, each of which exposes details of a particular file (you will learn the full details of the `FileInfo` type later in this chapter). Assume that you have the following static method of the `Program` class, which you call from `Main()`:

```
static void DisplayImageFiles()
{
    DirectoryInfo dir = new DirectoryInfo(@"C:\Windows\Web\Wallpaper");
    // Get all files with a *.jpg extension.
    FileInfo[] imageFiles = dir.GetFiles("*.jpg", SearchOption.AllDirectories);

    // How many were found?
    Console.WriteLine("Found {0} *.jpg files\n", imageFiles.Length);

    // Now print out info for each file.
    foreach (FileInfo f in imageFiles)
    {
        Console.WriteLine("*****");
        Console.WriteLine("File name: {0}", f.Name);
        Console.WriteLine("File size: {0}", f.Length);
        Console.WriteLine("Creation: {0}", f.CreationTime);
        Console.WriteLine("Attributes: {0}", f.Attributes);
        Console.WriteLine("*****\n");
    }
}
```

Notice that you specify a search option when you call `GetFiles()`; you do this to look within all subdirectories of the root. After you run the application, you will see a listing of all files that match the search pattern.

Creating Subdirectories with the `DirectoryInfo` Type

You can programmatically extend a directory structure using the `DirectoryInfo.CreateSubdirectory()` method. This method can create a single subdirectory, as well as multiple nested subdirectories, in a single function call. This method illustrates how to do so, extending the directory structure of the C: drive with some custom subdirectories:

```
static void ModifyAppDirectory()
{
    DirectoryInfo dir = new DirectoryInfo(@"C:\");

    // Create \MyFolder off application directory.
    dir.CreateSubdirectory("MyFolder");

    // Create \MyFolder2\Data off application directory.
    dir.CreateSubdirectory(@"MyFolder2\Data");
}
```

You are not required to capture the return value of the `CreateSubdirectory()` method, but you should be aware that a `DirectoryInfo` object representing the newly created item is passed back on successful execution. Consider the following update to the previous method. Note the dot notation in the constructor of `DirectoryInfo`, which gives you access to the application's installation point.

```
static void ModifyAppDirectory()
{
    DirectoryInfo dir = new DirectoryInfo(".");

    // Create \MyFolder off initial directory.
    dir.CreateSubdirectory("MyFolder");

    // Capture returned DirectoryInfo object.
    DirectoryInfo myDataFolder = dir.CreateSubdirectory(@"MyFolder2\Data");

    // Prints path to ..\MyFolder2\Data.
    Console.WriteLine("New Folder is: {0}", myDataFolder);
}
```

If you call this method from within `Main()` and examine your Windows directory using Windows Explorer, you will see that the new subdirectories are present and accounted for (see Figure 20-2).

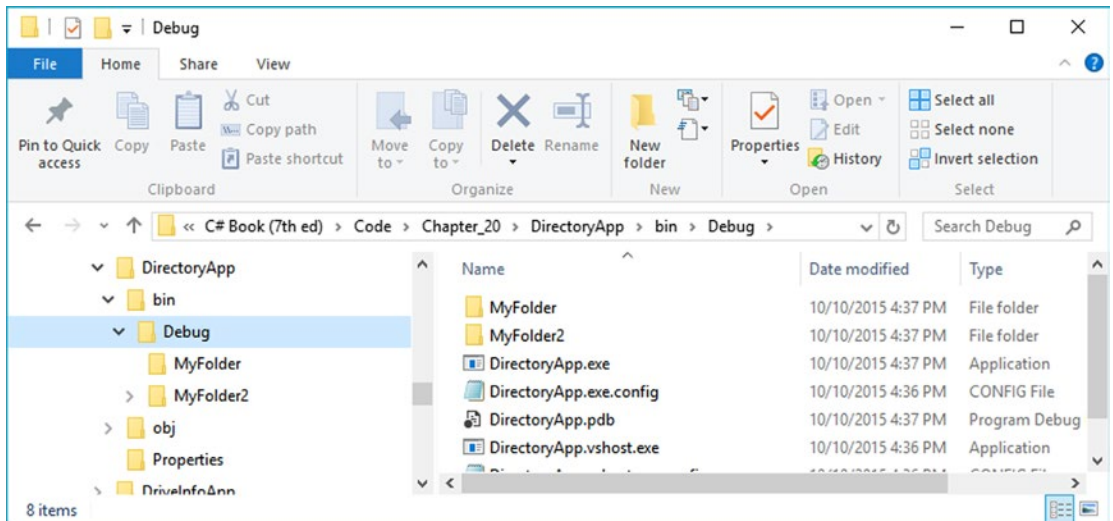

Figure 20-2. Creating subdirectories

Working with the Directory Type

You have seen the `DirectoryInfo` type in action; now you're ready to learn about the `Directory` type. For the most part, the static members of `Directory` mimic the functionality provided by the instance-level members defined by `DirectoryInfo`. Recall, however, that the members of `Directory` typically return string data rather than strongly typed `FileInfo/DirectoryInfo` objects.

Now let's look at some functionality of the `Directory` type; this final helper function displays the names of all drives mapped to the current computer (using the `Directory.GetLogicalDrives()` method) and uses the static `Directory.Delete()` method to remove the `\MyFolder` and `\MyFolder2\Data` subdirectories created previously.

```
static void FunWithDirectoryType()
{
    // List all drives on current computer.
    string[] drives = Directory.GetLogicalDrives();
    Console.WriteLine("Here are your drives:");
    foreach (string s in drives)
        Console.WriteLine("--> {0} ", s);

    // Delete what was created.
    Console.WriteLine("Press Enter to delete directories");
    Console.ReadLine();
    try
    {
        Directory.Delete(@"C:\MyFolder");

        // The second parameter specifies whether you
        // wish to destroy any subdirectories.
        Directory.Delete(@"C:\MyFolder2", true);
    }
    catch (IOException e)
    {
        Console.WriteLine(e.Message);
    }
}
```

■ **Source Code** You can find the `DirectoryApp` project in the [Chapter 20](#) subdirectory.

Working with the DriveInfo Class Type

The `System.IO` namespace provides a class named `DriveInfo`. Like `Directory.GetLogicalDrives()`, the static `DriveInfo.GetDrives()` method allows you to discover the names of a machine's drives. Unlike `Directory.GetLogicalDrives()`, however, `DriveInfo` provides numerous other details (e.g., the drive type, available free space, and volume label). Consider the following `Program` class defined within a new Console Application project named `DriveInfoApp` (don't forget to import `System.IO`):

```
class Program
{
    static void Main(string[] args)
    {
        Console.WriteLine("***** Fun with DriveInfo *****\n");

        // Get info regarding all drives.
        DriveInfo[] myDrives = DriveInfo.GetDrives();
        // Now print drive stats.
        foreach(DriveInfo d in myDrives)
        {
            Console.WriteLine("Name: {0}", d.Name);
            Console.WriteLine("Type: {0}", d.DriveType);

            // Check to see whether the drive is mounted.
            if(d.IsReady)
            {
                Console.WriteLine("Free space: {0}", d.TotalFreeSpace);
                Console.WriteLine("Format: {0}", d.DriveFormat);
                Console.WriteLine("Label: {0}", d.VolumeLabel);
            }
            Console.WriteLine();
        }
        Console.ReadLine();
    }
}
```

Here is some possible output:

```
***** Fun with DriveInfo *****

Name: C:\
Type: Fixed
Free space: 791699763200
Format: NTFS
Label: Windows10_05

Name: D:\
Type: Fixed
Free space: 23804067840
Format: NTFS
Label: LENOVO

Press any key to continue . . .
```

At this point, you have investigated some core behaviors of the `Directory`, `DirectoryInfo`, and `DriveInfo` classes. Next, you'll learn how to create, open, close, and destroy the files that populate a given directory.

■ **Source Code** You can find the `DriveInfoApp` project in the [Chapter 20](#) subdirectory.

Working with the `FileInfo` Class

As shown in the previous `DirectoryApp` example, the `FileInfo` class allows you to obtain details regarding existing files on your hard drive (e.g., time created, size, and file attributes) and aids in the creation, copying, moving, and destruction of files. In addition to the set of functionality inherited by `FileSystemInfo`, you can find some core members unique to the `FileInfo` class, which you can see described in [Table 20-4](#).

Table 20-4. *FileInfo Core Members*

| Member | Meaning in Life |
|----------------------------|---|
| <code>AppendText()</code> | Creates a <code>StreamWriter</code> object (described later) that appends text to a file |
| <code>CopyTo()</code> | Copies an existing file to a new file |
| <code>Create()</code> | Creates a new file and returns a <code>FileStream</code> object (described later) to interact with the newly created file |
| <code>CreateText()</code> | Creates a <code>StreamWriter</code> object that writes a new text file |
| <code>Delete()</code> | Deletes the file to which a <code>FileInfo</code> instance is bound |
| <code>Directory</code> | Gets an instance of the parent directory |
| <code>DirectoryName</code> | Gets the full path to the parent directory |
| <code>Length</code> | Gets the size of the current file |
| <code>MoveTo()</code> | Moves a specified file to a new location, providing the option to specify a new file name |
| <code>Name</code> | Gets the name of the file |
| <code>Open()</code> | Opens a file with various read/write and sharing privileges |
| <code>OpenRead()</code> | Creates a read-only <code>FileStream</code> object |
| <code>OpenText()</code> | Creates a <code>StreamReader</code> object (described later) that reads from an existing text file |
| <code>OpenWrite()</code> | Creates a write-only <code>FileStream</code> object |

Note that a majority of the methods of the `FileInfo` class return a specific I/O-centric object (e.g., `FileStream` and `StreamWriter`) that allows you to begin reading and writing data to (or reading from) the associated file in a variety of formats. You will check out these types in just a moment; however, before you see a working example, you'll find it helpful to examine various ways to obtain a file handle using the `FileInfo` class type.

The FileInfo.Create() Method

One way you can create a file handle is to use the `FileInfo.Create()` method, like so:

```
static void Main(string[] args)
{
    // Make a new file on the C drive.
    FileInfo f = new FileInfo(@"C:\Test.dat");
    FileStream fs = f.Create();

    // Use the FileStream object...

    // Close down file stream.
    fs.Close();
}
```

Notice that the `FileInfo.Create()` method returns a `FileStream` object, which exposes synchronous and asynchronous write/read operations to/from the underlying file (more details in a moment). Be aware that the `FileStream` object returned by `FileInfo.Create()` grants full read/write access to all users.

Also notice that after you finish with the current `FileStream` object, you must ensure you close down the handle to release the underlying unmanaged stream resources. Given that `FileStream` implements `IDisposable`, you can use the C# using scope to allow the compiler to generate the teardown logic (see Chapter 8 for details), like so:

```
static void Main(string[] args)
{
    // Defining a using scope for file I/O
    // types is ideal.
    FileInfo f = new FileInfo(@"C:\Test.dat");
    using (FileStream fs = f.Create())
    {
        // Use the FileStream object...
    }
}
```

The FileInfo.Open() Method

You can use the `FileInfo.Open()` method to open existing files, as well as to create new files with far more precision than you can with `FileInfo.Create()`. This works because `Open()` typically takes several parameters to qualify exactly how to iterate the file you want to manipulate. Once the call to `Open()` completes, you are returned a `FileStream` object. Consider the following logic:

```
static void Main(string[] args)
{
    // Make a new file via FileInfo.Open().
    FileInfo f2 = new FileInfo(@"C:\Test2.dat");
    using (FileStream fs2 = f2.Open(FileMode.OpenOrCreate,
        FileAccess.ReadWrite, FileShare.None))
    {
        // Use the FileStream object...
    }
}
```

This version of the overloaded `Open()` method requires three parameters. The first parameter of the `Open()` method specifies the general flavor of the I/O request (e.g., make a new file, open an existing file, and append to a file), which you specify using the `FileMode` enumeration (see Table 20-5 for details), like so:

```
public enum FileMode
{
    CreateNew,
    Create,
    Open,
    OpenOrCreate,
    Truncate,
    Append
}
```

Table 20-5. *Members of the FileMode Enumeration*

| Member | Meaning in Life |
|--------------|---|
| CreateNew | Informs the OS to make a new file. If it already exists, an <code>IOException</code> is thrown. |
| Create | Informs the OS to make a new file. If it already exists, it will be overwritten. |
| Open | Opens an existing file. If the file does not exist, a <code>FileNotFoundException</code> is thrown. |
| OpenOrCreate | Opens the file if it exists; otherwise, a new file is created. |
| Truncate | Opens an existing file and truncates the file to 0 bytes in size. |
| Append | Opens a file, moves to the end of the file, and begins write operations (you can use this flag only with a write-only stream). If the file does not exist, a new file is created. |

You use the second parameter of the `Open()` method, a value from the `FileAccess` enumeration, to determine the read/write behavior of the underlying stream, as follows:

```
public enum FileAccess
{
    Read,
    Write,
    ReadWrite
}
```

Finally, the third parameter of the `Open()` method, `FileShare`, specifies how to share the file among other file handlers. Here are the core names:

```
public enum FileShare
{
    Delete,
    Inheritable,
    None,
    Read,
    ReadWrite,
    Write
}
```

The FileInfo.OpenRead() and FileInfo.OpenWrite() Methods

The `FileInfo.Open()` method allows you to obtain a file handle in a flexible manner, but the `FileInfo` class also provides members named `OpenRead()` and `OpenWrite()`. As you might imagine, these methods return a properly configured read-only or write-only `FileStream` object, without the need to supply various enumeration values. Like `FileInfo.Create()` and `FileInfo.Open()`, `OpenRead()` and `OpenWrite()` return a `FileStream` object (note that the following code assumes you have files named `Test3.dat` and `Test4.dat` on your C: drive):

```
static void Main(string[] args)
{
    // Get a FileStream object with read-only permissions.
    FileInfo f3 = new FileInfo(@"C:\Test3.dat");
    using(FileStream readOnlyStream = f3.OpenRead())
    {
        // Use the FileStream object...
    }

    // Now get a FileStream object with write-only permissions.
    FileInfo f4 = new FileInfo(@"C:\Test4.dat");
    using(FileStream writeOnlyStream = f4.OpenWrite())
    {
        // Use the FileStream object...
    }
}
```

The FileInfo.OpenText() Method

Another open-centric member of the `FileInfo` type is `OpenText()`. Unlike `Create()`, `Open()`, `OpenRead()`, or `OpenWrite()`, the `OpenText()` method returns an instance of the `StreamReader` type, rather than a `FileStream` type. Assuming you have a file named `boot.ini` on your C: drive, the following snippet gives you access to its contents:

```
static void Main(string[] args)
{
    // Get a StreamReader object.
    FileInfo f5 = new FileInfo(@"C:\boot.ini");
    using(StreamReader sreader = f5.OpenText())
    {
        // Use the StreamReader object...
    }
}
```

As you will see shortly, the `StreamReader` type provides a way to read character data from the underlying file.

The FileInfo.CreateText() and FileInfo.AppendText() Methods

The final two `FileInfo` methods of interest at this point are `CreateText()` and `AppendText()`. Both return a `StreamWriter` object, as shown here:

```
static void Main(string[] args)
{
    FileInfo f6 = new FileInfo(@"C:\Test6.txt");
    using(StreamWriter swriter = f6.CreateText())
    {
        // Use the StreamWriter object...
    }

    FileInfo f7 = new FileInfo(@"C:\FinalTest.txt");
    using(StreamWriter swriterAppend = f7.AppendText())
    {
        // Use the StreamWriter object...
    }
}
```

As you might guess, the `StreamWriter` type provides a way to write character data to the underlying file.

Working with the File Type

The `File` type uses several static members to provide functionality almost identical to that of the `FileInfo` type. Like `FileInfo`, `File` supplies `AppendText()`, `Create()`, `CreateText()`, `Open()`, `OpenRead()`, `OpenWrite()`, and `OpenText()` methods. In many cases, you can use the `File` and `FileInfo` types interchangeably. To see this in action, you can simplify each of the previous `FileStream` examples by using the `File` type instead, like so:

```
static void Main(string[] args)
{
    // Obtain FileStream object via File.Create().
    using(FileStream fs = File.Create(@"C:\Test.dat"))
    {}

    // Obtain FileStream object via File.Open().
    using(FileStream fs2 = File.Open(@"C:\Test2.dat",
        FileMode.OpenOrCreate,
        FileAccess.ReadWrite, FileShare.None))
    {}

    // Get a FileStream object with read-only permissions.
    using(FileStream readOnlyStream = File.OpenRead(@"Test3.dat"))
    {}

    // Get a FileStream object with write-only permissions.
    using(FileStream writeOnlyStream = File.OpenWrite(@"Test4.dat"))
    {}
}
```

```

// Get a StreamReader object.
using(StreamReader sreader = File.OpenText(@"C:\boot.ini"))
{}

// Get some StreamWriters.
using(StreamWriter swriter = File.CreateText(@"C:\Test6.txt"))
{}

using(StreamWriter swriterAppend = File.AppendText(@"C:\FinalTest.txt"))
{}
}

```

Additional File-Centric Members

The File type also supports a few members, shown in Table 20-6, which can greatly simplify the processes of reading and writing textual data.

Table 20-6. *Methods of the File Type*

| Method | Meaning in Life |
|-----------------|---|
| ReadAllBytes() | Opens the specified file, returns the binary data as an array of bytes, and then closes the file |
| ReadAllLines() | Opens a specified file, returns the character data as an array of strings, and then closes the file |
| ReadAllText() | Opens a specified file, returns the character data as a System.String, and then closes the file |
| WriteAllBytes() | Opens the specified file, writes out the byte array, and then closes the file |
| WriteAllLines() | Opens a specified file, writes out an array of strings, and then closes the file |
| WriteAllText() | Opens a specified file, writes the character data from a specified string, and then closes the file |

You can use these methods of the File type to read and write batches of data in only a few lines of code. Even better, each of these members automatically closes down the underlying file handle. For example, the following console program (named SimpleFileIO) persists the string data into a new file on the C: drive (and reads it into memory) with minimal fuss (this example assumes you have imported System.IO):

```

class Program
{
    static void Main(string[] args)
    {
        Console.WriteLine("***** Simple I/O with the File Type *****\n");
        string[] myTasks = {
            "Fix bathroom sink", "Call Dave",
            "Call Mom and Dad", "Play Xbox One"};
    }
}

```

```

// Write out all data to file on C drive.
File.WriteAllLines(@"C:\tasks.txt", myTasks);

// Read it all back and print out.
foreach (string task in File.ReadAllLines(@"C:\tasks.txt"))
{
    Console.WriteLine("TODO: {0}", task);
}
Console.ReadLine();
}
}

```

The lesson here is that when you want to obtain a file handle quickly, the `File` type will save you some keystrokes. However, one benefit of creating a `FileInfo` object first is that you can investigate the file using the members of the abstract `FileSystemInfo` base class.

■ **Source Code** You can find the `SimpleFileIO` project in the [Chapter 20](#) subdirectory.

The Abstract Stream Class

At this point, you have seen many ways to obtain `FileStream`, `StreamReader`, and `StreamWriter` objects, but you have yet to read data from or write data to a file using these types. To understand how to do this, you'll need to familiarize yourself with the concept of a *stream*. In the world of I/O manipulation, a *stream* represents a chunk of data flowing between a source and a destination. Streams provide a common way to interact with *a sequence of bytes*, regardless of what kind of device (e.g., file, network connection, or printer) stores or displays the bytes in question.

The abstract `System.IO.Stream` class defines several members that provide support for synchronous and asynchronous interactions with the storage medium (e.g., an underlying file or memory location).

■ **Note** The concept of a stream is not limited to file I/O. To be sure, the .NET libraries provide stream access to networks, memory locations, and other stream-centric abstractions.

Again, `Stream` descendants represent data as a raw stream of bytes; therefore, working directly with raw streams can be quite cryptic. Some `Stream`-derived types support *seeking*, which refers to the process of obtaining and adjusting the current position in the stream. [Table 20-7](#) helps you understand the functionality provided by the `Stream` class by describing its core members.

Table 20-7. *Abstract Stream Members*

| Member | Meaning in Life |
|--|---|
| CanRead CanWrite CanSeek | Determines whether the current stream supports reading, seeking, and/or writing. |
| Close() | Closes the current stream and releases any resources (such as sockets and file handles) associated with the current stream. Internally, this method is aliased to the <code>Dispose()</code> method; therefore, <i>closing a stream</i> is functionally equivalent to <i>disposing a stream</i> . |
| Flush() | Updates the underlying data source or repository with the current state of the buffer and then clears the buffer. If a stream does not implement a buffer, this method does nothing. |
| Length | Returns the length of the stream in bytes. |
| Position | Determines the position in the current stream. |
| Read() ReadByte() ReadAsync() | Reads a sequence of bytes (or a single byte) from the current stream and advances the current position in the stream by the number of bytes read. |
| Seek() | Sets the position in the current stream. |
| SetLength() | Sets the length of the current stream. |
| Write() WriteByte() WriteAsync() | Writes a sequence of bytes (or a single byte) to the current stream and advances the current position in this stream by the number of bytes written. |

Working with FileStreams

The `FileStream` class provides an implementation for the abstract `Stream` members in a manner appropriate for file-based streaming. It is a fairly primitive stream; it can read or write only a single byte or an array of bytes. However, you will not often need to interact directly with the members of the `FileStream` type. Instead, you will probably use various *stream wrappers*, which make it easier to work with textual data or .NET types. Nevertheless, you will find it helpful to experiment with the synchronous read/write capabilities of the `FileStream` type.

Assume you have a new Console Application project named `FileStreamApp` (and verify that `System.IO` and `System.Text` are imported into your initial C# code file). Your goal is to write a simple text message to a new file named `myMessage.dat`. However, given that `FileStream` can operate only on raw bytes, you will be required to encode the `System.String` type into a corresponding byte array. Fortunately, the `System.Text` namespace defines a type named `Encoding` that provides members that encode and decode strings to (or from) an array of bytes (check out the .NET Framework SDK documentation for more details about the `Encoding` type).

Once encoded, the byte array is persisted to file with the `FileStream.Write()` method. To read the bytes back into memory, you must reset the internal position of the stream (using the `Position` property) and call the `ReadByte()` method. Finally, you display the raw byte array and the decoded string to the console. Here is the complete `Main()` method:

```
// Don't forget to import the System.Text and System.IO namespaces.
static void Main(string[] args)
{
    Console.WriteLine("***** Fun with FileStreams *****\n");

    // Obtain a FileStream object.
    using(FileStream fStream = File.Open(@"C:\myMessage.dat",
        FileMode.Create))
    {
        // Encode a string as an array of bytes.
        string msg = "Hello!";
        byte[] msgAsByteArray = Encoding.Default.GetBytes(msg);

        // Write byte[] to file.
        fStream.Write(msgAsByteArray, 0, msgAsByteArray.Length);

        // Reset internal position of stream.
        fStream.Position = 0;

        // Read the bytes from file and display to console.
        Console.WriteLine("Your message as an array of bytes: ");
        byte[] bytesFromFile = new byte[msgAsByteArray.Length];
        for (int i = 0; i < msgAsByteArray.Length; i++)
        {
            bytesFromFile[i] = (byte)fStream.ReadByte();
            Console.WriteLine(bytesFromFile[i]);
        }

        // Display decoded messages.
        Console.WriteLine("\nDecoded Message: ");
        Console.WriteLine(Encoding.Default.GetString(bytesFromFile));
    }
    Console.ReadLine();
}
```

This example populates the file with data, but it also punctuates the major downfall of working directly with the `FileStream` type: it demands to operate on raw bytes. Other `Stream`-derived types operate in a similar manner. For example, if you want to write a sequence of bytes to a region of memory, you can allocate a `MemoryStream`. Likewise, if you want to push an array of bytes through a network connection, you can use the `NetworkStream` class (in the `System.Net.Sockets` namespace).

As mentioned previously, the `System.IO` namespace provides several *reader* and *writer* types that encapsulate the details of working with `Stream`-derived types.

■ **Source Code** You can find the `FileStreamApp` project in the Chapter 20 subdirectory.

Working with StreamWriters and StreamReaders

The `StreamWriter` and `StreamReader` classes are useful whenever you need to read or write character-based data (e.g., strings). Both of these types work by default with Unicode characters; however, you can change this by supplying a properly configured `System.Text.Encoding` object reference. To keep things simple, assume that the default Unicode encoding fits the bill.

`StreamReader` derives from an abstract type named `TextReader`, as does the related `StringReader` type (discussed later in this chapter). The `TextReader` base class provides a limited set of functionality to each of these descendants; specifically, it provides the ability to read and peek into a character stream.

The `StreamWriter` type (as well as `StringWriter`, which you will examine later in this chapter) derives from an abstract base class named `TextWriter`. This class defines members that allow derived types to write textual data to a given character stream.

To aid in your understanding of the core writing capabilities of the `StreamWriter` and `StringWriter` classes, Table 20-8 describes the core members of the abstract `TextWriter` base class.

Table 20-8. Core Members of `TextWriter`

| Member | Meaning in Life |
|---|---|
| <code>Close()</code> | This method closes the writer and frees any associated resources. In the process, the buffer is automatically flushed (again, this member is functionally equivalent to calling the <code>Dispose()</code> method). |
| <code>Flush()</code> | This method clears all buffers for the current writer and causes any buffered data to be written to the underlying device; however, it does not close the writer. |
| <code>NewLine</code> | This property indicates the newline constant for the derived writer class. The default line terminator for the Windows OS is a carriage return, followed by a line feed (<code>\r\n</code>). |
| <code>Write()</code> <code>WriteAsync()</code> | This overloaded method writes data to the text stream without a newline constant. |
| <code>WriteLine()</code> <code>WriteLineAsync()</code> | This overloaded method writes data to the text stream with a newline constant. |

■ **Note** The last two members of the `TextWriter` class probably look familiar to you. If you recall, the `System.Console` type has `Write()` and `WriteLine()` members that push textual data to the standard output device. In fact, the `Console.In` property wraps a `TextReader`, and the `Console.Out` property wraps a `TextWriter`.

The derived `StreamWriter` class provides an appropriate implementation for the `Write()`, `Close()`, and `Flush()` methods, and it defines the additional `AutoFlush` property. When set to `true`, this property forces `StreamWriter` to flush all data every time you perform a write operation. Be aware that you can gain better performance by setting `AutoFlush` to `false`, provided you always call `Close()` when you finish writing with a `StreamWriter`.

Writing to a Text File

To see the `StreamWriter` type in action, create a new Console Application project named `StreamWriterReaderApp` and import `System.IO`. The following `Main()` method creates a new file named `reminders.txt` in the current execution folder, using the `File.CreateText()` method. Using the obtained `StreamWriter` object, you can add some textual data to the new file.

```
static void Main(string[] args)
{
    Console.WriteLine("***** Fun with StreamWriter / StreamReader *****\n");

    // Get a StreamWriter and write string data.
    using(StreamWriter writer = File.CreateText("reminders.txt"))
    {
        writer.WriteLine("Don't forget Mother's Day this year...");
        writer.WriteLine("Don't forget Father's Day this year...");
        writer.WriteLine("Don't forget these numbers:");
        for(int i = 0; i < 10; i++)
            writer.Write(i + " ");

        // Insert a new line.
        writer.Write(writer.NewLine);
    }

    Console.WriteLine("Created file and wrote some thoughts...");
    Console.ReadLine();
}
```

After you run this program, you can examine the contents of this new file (see Figure 20-3). You will find this file under the `bin\Debug` folder of your current application because you did not specify an absolute path at the time you called `CreateText()`.

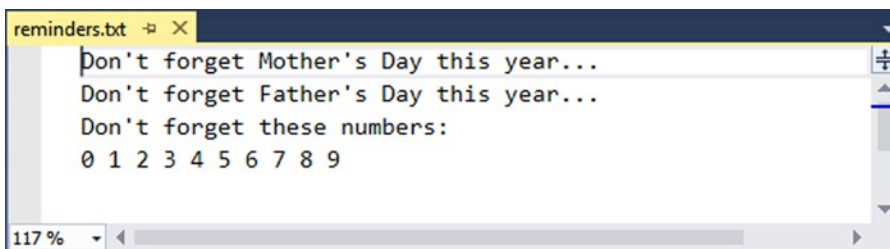

Figure 20-3. The contents of your *.txt file

Reading from a Text File

Next, you will learn to read data from a file programmatically by using the corresponding `StreamReader` type. Recall that this class derives from the abstract `TextReader`, which offers the functionality described in Table 20-9.

Table 20-9. *TextReader Core Members*

| Member | Meaning in Life |
|---|--|
| <code>Peek()</code> | Returns the next available character (expressed as an integer) without actually changing the position of the reader. A value of -1 indicates you are at the end of the stream. |
| <code>Read()</code> <code>ReadAsync()</code> | Reads data from an input stream. |
| <code>ReadBlock()</code> <code>ReadBlockAsync()</code> | Reads a specified maximum number of characters from the current stream and writes the data to a buffer, beginning at a specified index. |
| <code>ReadLine()</code> <code>ReadLineAsync()</code> | Reads a line of characters from the current stream and returns the data as a string (a null string indicates EOF). |
| <code>ReadToEnd()</code> <code>ReadToEndAsync()</code> | Reads all characters from the current position to the end of the stream and returns them as a single string. |

If you now extend the current sample application to use a `StreamReader`, you can read in the textual data from the `reminders.txt` file, as shown here:

```
static void Main(string[] args)
{
    Console.WriteLine("***** Fun with StreamWriter / StreamReader *****\n");
    ...
    // Now read data from file.
    Console.WriteLine("Here are your thoughts:\n");
    using(StreamReader sr = File.OpenText("reminders.txt"))
    {
        string input = null;
        while ((input = sr.ReadLine()) != null)
        {
            Console.WriteLine (input);
        }
    }
    Console.ReadLine();
}
```

After you run the program, you will see the character data in `reminders.txt` displayed to the console.

Directly Creating StreamWriter/StreamReader Types

One of the confusing aspects of working with the types within `System.IO` is that you can often achieve an identical result using different approaches. For example, you have already seen that you can use the `CreateText()` method to obtain a `StreamWriter` with the `File` or `FileInfo` type. It so happens that you can work with `StreamWriters` and `StreamReaders` another way: by creating them directly. For example, you could retrofit the current application as follows:

```
static void Main(string[] args)
{
    Console.WriteLine("***** Fun with StreamWriter / StreamReader *****\n");

    // Get a StreamWriter and write string data.
    using(StreamWriter writer = new StreamWriter("reminders.txt"))
    {
        ...
    }

    // Now read data from file.
    using(StreamReader sr = new StreamReader("reminders.txt"))
    {
        ...
    }
}
```

Although it can be a bit confusing to see so many seemingly identical approaches to file I/O, keep in mind that the end result is greater flexibility. In any case, you are now ready to examine the role of the `StringWriter` and `StringReader` classes, given that you have seen how to move character data to and from a given file using the `StreamWriter` and `StreamReader` types.

■ **Source Code** You can find the `StreamWriterReaderApp` project in the [Chapter 20](#) subdirectory.

Working with StringWriters and StringReaders

You can use the `StringWriter` and `StringReader` types to treat textual information as a stream of in-memory characters. This can prove helpful when you would like to append character-based information to an underlying buffer. The following Console Application project (named `StringReaderWriterApp`) illustrates this by writing a block of string data to a `StringWriter` object, rather than to a file on the local hard drive (don't forget to import `System.IO`):

```
static void Main(string[] args)
{
    Console.WriteLine("***** Fun with StringWriter / StringReader *****\n");

    // Create a StringWriter and emit character data to memory.
    using(StringWriter strWriter = new StringWriter())
    {
        strWriter.WriteLine("Don't forget Mother's Day this year...");
    }
}
```

```

// Get a copy of the contents (stored in a string) and dump
// to console.
    Console.WriteLine("Contents of StringWriter:\n{0}", strWriter);
}
Console.ReadLine();
}

```

StringWriter and StreamWriter both derive from the same base class (TextWriter), so the writing logic is more or less identical. However, given the nature of StringWriter, you should also be aware that this class allows you to use the following GetStringBuilder() method to extract a System.Text.StringBuilder object:

```

using (StringWriter strWriter = new StringWriter())
{
    strWriter.WriteLine("Don't forget Mother's Day this year...");
    Console.WriteLine("Contents of StringWriter:\n{0}", strWriter);

    // Get the internal StringBuilder.
    StringBuilder sb = strWriter.GetStringBuilder();
    sb.Insert(0, "Hey!! ");
    Console.WriteLine("-> {0}", sb.ToString());
    sb.Remove(0, "Hey!! ".Length);
    Console.WriteLine("-> {0}", sb.ToString());
}

```

When you want to read from a stream of character data, you can use the corresponding StringReader type, which (as you would expect) functions identically to the related StreamReader class. In fact, the StringReader class does nothing more than override the inherited members to read from a block of character data, rather than from a file, as shown here:

```

using (StringWriter strWriter = new StringWriter())
{
    strWriter.WriteLine("Don't forget Mother's Day this year...");
    Console.WriteLine("Contents of StringWriter:\n{0}", strWriter);

    // Read data from the StringWriter.
    using (StringReader strReader = new StringReader(strWriter.ToString()))
    {
        string input = null;
        while ((input = strReader.ReadLine()) != null)
        {
            Console.WriteLine(input);
        }
    }
}

```

■ **Source Code** You can find the StringReaderWriterApp in the Chapter 20 subdirectory.

Working with BinaryWriters and BinaryReaders

The final writer/reader sets you will examine in this section are `BinaryReader` and `BinaryWriter`. Both derive directly from `System.Object`. These types allow you to read and write discrete data types to an underlying stream in a compact binary format. The `BinaryWriter` class defines a highly overloaded `Write()` method to place a data type in the underlying stream. In addition to the `Write()` member, `BinaryWriter` provides additional members that allow you to get or set the `Stream`-derived type; it also offers support for random access to the data (see Table 20-10).

Table 20-10. *BinaryWriter Core Members*

| Member | Meaning in Life |
|-------------------------|--|
| <code>BaseStream</code> | This read-only property provides access to the underlying stream used with the <code>BinaryWriter</code> object. |
| <code>Close()</code> | This method closes the binary stream. |
| <code>Flush()</code> | This method flushes the binary stream. |
| <code>Seek()</code> | This method sets the position in the current stream. |
| <code>Write()</code> | This method writes a value to the current stream. |

The `BinaryReader` class complements the functionality offered by `BinaryWriter` with the members described in Table 20-11.

Table 20-11. *BinaryReader Core Members*

| Member | Meaning in Life |
|-------------------------|---|
| <code>BaseStream</code> | This read-only property provides access to the underlying stream used with the <code>BinaryReader</code> object. |
| <code>Close()</code> | This method closes the binary reader. |
| <code>PeekChar()</code> | This method returns the next available character without advancing the position in the stream. |
| <code>Read()</code> | This method reads a given set of bytes or characters and stores them in the incoming array. |
| <code>ReadXXXX()</code> | The <code>BinaryReader</code> class defines numerous read methods that grab the next type from the stream (e.g., <code>ReadBoolean()</code> , <code>ReadByte()</code> , and <code>ReadInt32()</code>). |

The following example (a Console Application project named `BinaryWriterReader`) writes a number of data types to a new `*.dat` file:

```
static void Main(string[] args)
{
    Console.WriteLine("***** Fun with Binary Writers / Readers *****\n");

    // Open a binary writer for a file.
    FileInfo f = new FileInfo("BinFile.dat");
    using(BinaryWriter bw = new BinaryWriter(f.OpenWrite()))
```

```

{
    // Print out the type of BaseStream.
    // (System.IO.FileStream in this case).
    Console.WriteLine("Base stream is: {0}", bw.BaseStream);

    // Create some data to save in the file.
    double aDouble = 1234.67;
    int anInt = 34567;
    string aString = "A, B, C";

    // Write the data.
    bw.Write(aDouble);
    bw.Write(anInt);
    bw.Write(aString);
}
Console.WriteLine("Done!");
Console.ReadLine();
}

```

Notice how the `FileStream` object returned from `FileInfo.OpenWrite()` is passed to the constructor of the `BinaryWriter` type. Using this technique makes it easy to *layer in* a stream before writing out the data. Note that the constructor of `BinaryWriter` takes any `Stream`-derived type (e.g., `FileStream`, `MemoryStream`, or `BufferedStream`). Thus, writing binary data to memory instead is as simple as supplying a valid `MemoryStream` object.

To read the data out of the `BinFile.dat` file, the `BinaryReader` type provides a number of options. Here, you call various read-centric members to pluck each chunk of data from the file stream:

```

static void Main(string[] args)
{
    ...
    FileInfo f = new FileInfo("BinFile.dat");
    ...
    // Read the binary data from the stream.
    using(BinaryReader br = new BinaryReader(f.OpenRead()))
    {
        Console.WriteLine(br.ReadDouble());
        Console.WriteLine(br.ReadInt32());
        Console.WriteLine(br.ReadString());
    }
    Console.ReadLine();
}

```

■ **Source Code** You can find the `BinaryWriterReader` application in the Chapter 20 subdirectory.

Watching Files Programmatically

Now that you have a better handle on the use of various readers and writers, you'll look at the role of the `FileSystemWatcher` class. This type can be quite helpful when you want to monitor (or “watch”) files on your system programmatically. Specifically, you can instruct the `FileSystemWatcher` type to monitor files for any of the actions specified by the `System.IO.NotifyFilters` enumeration (many of these members are self-explanatory, but you should still check the .NET Framework 4.6 SDK documentation for more details).

```
public enum NotifyFilters
{
    Attributes, CreationTime,
    DirectoryName, FileName,
    LastAccess, LastWrite,
    Security, Size
}
```

To begin working with the `FileSystemWatcher` type, you need to set the `Path` property to specify the name (and location) of the directory that contains the files you want to monitor, as well as the `Filter` property that defines the file extensions of the files you want to monitor.

At this point, you may choose to handle the `Changed`, `Created`, and `Deleted` events, all of which work in conjunction with the `FileSystemEventHandler` delegate. This delegate can call any method matching the following pattern:

```
// The FileSystemEventHandler delegate must point  
// to methods matching the following signature.  
void MyNotificationHandler(object source, FileSystemEventArgs e)
```

You can also handle the `Renamed` event using the `RenamedEventHandler` delegate type, which can call methods that match the following signature:

```
// The RenamedEventHandler delegate must point  
// to methods matching the following signature.  
void MyRenamedHandler(object source, RenamedEventArgs e)
```

While you could use the traditional delegate/event syntax to handle each event, you can certainly make use of lambda expression syntax as well (the downloadable code for this project uses lambda syntax, if you are interested).

Next, let's look at the process of watching a file. Assume you have created a new directory on your C: drive named `MyFolder` that contains various `*.txt` files (named whatever you like). The following Console Application project (named `MyDirectoryWatcher`) monitors the `*.txt` files in the `MyFolder` directory and prints messages when files are created, deleted, modified, or renamed:

```
static void Main(string[] args)
{
    Console.WriteLine("***** The Amazing File Watcher App *****\n");
    // Establish the path to the directory to watch.
    FileSystemWatcher watcher = new FileSystemWatcher();
    try
```

```

{
    watcher.Path = @"C:\MyFolder";
}
catch (ArgumentException ex)
{
    Console.WriteLine(ex.Message);
    return;
}
// Set up the things to be on the lookout for.
watcher.NotifyFilter = NotifyFilters.LastAccess
    | NotifyFilters.LastWrite
    | NotifyFilters.FileName
    | NotifyFilters.DirectoryName;

// Only watch text files.
watcher.Filter = "*.txt";

// Add event handlers.
watcher.Changed += new FileSystemEventHandler(OnChanged);
watcher.Created += new FileSystemEventHandler(OnChanged);
watcher.Deleted += new FileSystemEventHandler(OnChanged);
watcher.Renamed += new RenamedEventHandler(OnRenamed);

// Begin watching the directory.
watcher.EnableRaisingEvents = true;

// Wait for the user to quit the program.
Console.WriteLine(@"Press 'q' to quit app.");
while (Console.Read() != 'q')
;
}

```

The following two event handlers simply print the current file modification:

```

static void OnChanged(object source, FileSystemEventArgs e)
{
    // Specify what is done when a file is changed, created, or deleted.
    Console.WriteLine("File: {0} {1}!", e.FullPath, e.ChangeType);
}

static void OnRenamed(object source, RenamedEventArgs e)
{
    // Specify what is done when a file is renamed.
    Console.WriteLine("File: {0} renamed to {1}", e.OldFullPath, e.FullPath);
}

```

To test this program, run the application and open Windows Explorer. Try renaming your files, creating a *.txt file, deleting a *.txt file, and so forth. You will see various bits of information generated about the state of the text files within your MyFolder, as in this example:

```
***** The Amazing File Watcher App *****

Press 'q' to quit app.
File: C:\MyFolder\New Text Document.txt Created!
File: C:\MyFolder\New Text Document.txt renamed to C:\MyFolder\Hello.txt
File: C:\MyFolder\Hello.txt Changed!
File: C:\MyFolder\Hello.txt Changed!
File: C:\MyFolder\Hello.txt Deleted!
```

■ **Source Code** You can find the MyDirectoryWatcher application in the [Chapter 20](#) subdirectory.

That wraps up this chapter's look at fundamental I/O operations within the .NET platform. While you will certainly use these techniques in many of your applications, you might also find that *object serialization* services can greatly simplify how you persist large amounts of data.

Understanding Object Serialization

The term *serialization* describes the process of persisting (and possibly transferring) the state of an object into a stream (e.g., file stream and memory stream). The persisted data sequence contains all the necessary information you need to reconstruct (or *deserialize*) the state of the object for use later. Using this technology makes it trivial to save vast amounts of data (in various formats). In many cases, saving application data using serialization services results in less code than using the readers/writers you find in the `System.IO` namespace.

For example, assume you want to create a GUI-based desktop application that provides a way for end users to save their preferences (e.g., window color and font size). To do this, you might define a class named `UserPrefs` that encapsulates 20 or so pieces of field data. Now, if you were to use a `System.IO.BinaryWriter` type, you would need to save each field of the `UserPrefs` object *manually*. Likewise, if you were to load the data from a file back into memory, you would need to use a `System.IO.BinaryReader` and (once again) *manually* read in each value to reconfigure a new `UserPrefs` object.

This is all doable, but you can save yourself a good amount of time by marking the `UserPrefs` class with the `[Serializable]` attribute, like so:

```
[Serializable]
public class UserPrefs
{
    public string WindowColor;
    public int FontSize;
}
```

Doing this means that you can persist entire state of the object with only a few lines of code. Without getting hung up on the details for the time being, consider the following `Main()` method:

```
static void Main(string[] args)
{
    UserPrefs userData= new UserPrefs();
    userData.WindowColor = "Yellow";
    userData.FontSize = 50;

    // The BinaryFormatter persists state data in a binary format.
    // You would need to import System.Runtime.Serialization.Formatters.Binary
    // to gain access to BinaryFormatter.
    BinaryFormatter binFormat = new BinaryFormatter();

    // Store object in a local file.
    using(Stream fStream = new FileStream("user.dat",
        FileMode.Create, FileAccess.Write, FileShare.None))
    {
        binFormat.Serialize(fStream, userData);
    }
    Console.ReadLine();
}
```

.NET object serialization makes it easy to persist objects; however, the processes used behind the scenes are quite sophisticated. For example, when an object is persisted to a stream, all associated data (e.g., base class data and contained objects) are automatically serialized, as well. Therefore, if you attempt to persist a derived class, all data up the chain of inheritance comes along for the ride. As you will see, you use an object graph to represent a set of interrelated objects.

.NET serialization services also allow you to persist an object graph in a variety of formats. The previous code example uses the `BinaryFormatter` type; therefore, the state of the `UserPrefs` object is persisted as a compact binary format. You can also persist an object graph into SOAP or XML format using other types. These formats can be quite helpful when you need to ensure that your persisted objects travel well across operating systems, languages, and architectures.

■ **Note** WCF prefers a slightly different mechanism for serializing objects to/from WCF service operations; it uses the `[DataContract]` and `[DataMember]` attributes. You'll learn more about this in [Chapter 25](#).

Finally, understand that you can persist an object graph into *any* `System.IO.Stream`-derived type. In the previous example, you used the `FileStream` type to persist a `UserPrefs` object into a local file. However, if you would rather store an object to a specific region of memory, you could use a `MemoryStream` type instead. All that matters is that the sequence of data correctly represents the state of objects within the graph.

The Role of Object Graphs

As mentioned previously, the CLR will account for all related objects to ensure that data is persisted correctly when an object is serialized. This set of related objects is referred to as an *object graph*. Object graphs provide a simple way to document how a set of items refer to each other. Be aware that object graphs are *not* denoting OOP is-a or has-a relationships. Rather, you can read the arrows in an object diagram as “requires” or “depends on.”

Each object in an object graph is assigned a unique numerical value. Keep in mind that the numbers assigned to the members in an object graph are arbitrary and have no real meaning to the outside world.

Once you assign all objects a numerical value, the object graph can record each object’s set of dependencies.

For example, assume you have created a set of classes that model some automobiles (of course). You have a base class named `Car`, which *has-a* `Radio`. Another class named `JamesBondCar` extends the `Car` base type. Figure 20-4 shows a possible object graph that models these relationships.

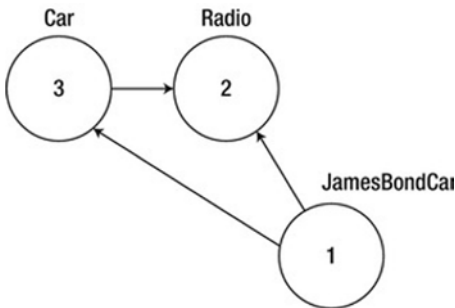

Figure 20-4. A simple object graph

When reading object graphs, you can use the phrase *depends on* or *refers to* when connecting the arrows. Thus, in Figure 20-4, you can see that the `Car` refers to the `Radio` class (given the *has-a* relationship). `JamesBondCar` refers to `Car` (given the is-a relationship), as well as to `Radio` (it inherits this protected member variable).

Of course, the CLR does not paint pictures in memory to represent a graph of related objects. Rather, the relationship documented in Figure 20-4 is represented by a mathematical formula that looks something like this:

```
[Car 3, ref 2], [Radio 2], [JamesBondCar 1, ref 3, ref 2]
```

If you parse this formula, you can see that object 3 (the `Car`) has a dependency on object 2 (the `Radio`). Object 2, the `Radio`, is a lone wolf and requires nobody. Finally, object 1 (the `JamesBondCar`) has a dependency on object 3, as well as object 2. In any case, when you serialize or deserialize an instance of `JamesBondCar`, the object graph ensures that the `Radio` and `Car` types also participate in the process.

The beautiful thing about the serialization process is that the graph representing the relationships among your objects is established automatically behind the scenes. As you will see later in this chapter, however, you can become more involved in the construction of a given object graph by customizing the serialization process using attributes and interfaces.

■ **Note** Strictly speaking, the `XmlSerializer` type (described later in this chapter) does not persist state using object graphs; however, this type still serializes and deserializes related objects in a predictable manner.

Configuring Objects for Serialization

To make an object available to .NET serialization services, all you need to do is decorate each related class (or structure) with the `[Serializable]` attribute. If you determine that a given type has some member data that should not (or perhaps cannot) participate in the serialization scheme, you can mark such fields with the `[NonSerialized]` attribute. This can be helpful if you would like to reduce the size of the persisted data and you have member variables in a serializable class that do not need to be remembered (e.g., fixed values, random values, and transient data).

Defining Serializable Types

To get the ball rolling, create a new Console Application project named `SimpleSerialize`. Insert a new class named `Radio`, which has been marked `[Serializable]`, excluding a single member variable (`radioID`) that has been marked `[NonSerialized]` and will, therefore, not be persisted into the specified data stream.

```
[Serializable]
public class Radio
{
    public bool hasTweeters;
    public bool hasSubWoofers;
    public double[] stationPresets;

    [NonSerialized]
    public string radioID = "XF-552RR6";
}
```

Next, insert two additional class types to represent the `JamesBondCar` and `Car` classes, both of which are also marked `[Serializable]` and define the following pieces of field data:

```
[Serializable]
public class Car
{
    public Radio theRadio = new Radio();
    public bool isHatchBack;
}

[Serializable]
public class JamesBondCar : Car
{
    public bool canFly;
    public bool canSubmerge;
}
```

Be aware that you cannot inherit the `[Serializable]` attribute from a parent class. Therefore, if you derive a class from a type marked `[Serializable]`, the child class must be marked `[Serializable]` as well, or it cannot be persisted. In fact, all objects in an object graph must be marked with the `[Serializable]` attribute. If you attempt to serialize a nonserializable object using the `BinaryFormatter` or `SoapFormatter`, you will receive a `SerializationException` at runtime.

Public Fields, Private Fields, and Public Properties

Notice that in each of these classes you define the field data as public; this helps keep the example simple. Of course, private data exposed using public properties would be preferable from an OO point of view. Also, for the sake of simplicity, this example does not define any custom constructors on these types; therefore, all unassigned field data will receive the expected default values.

OO design principles aside, you might wonder how the various formatters expect a type's field data to be defined in order to be serialized into a stream. The answer is that it depends. If you persist an object's state using the `BinaryFormatter` or `SoapFormatter`, it makes absolutely no difference. These types are programmed to serialize *all* serializable fields of a type, regardless of whether they are public fields, private fields, or private fields exposed through public properties. Recall, however, that if you have points of data that you do not want to be persisted into the object graph, you can selectively mark public or private fields as `[NonSerialized]`, as you do with the string field of the `Radio` type.

The situation is quite different if you use the `XmlSerializer` type, however. This type will *only* serialize public data fields or private data exposed by public properties. Private data not exposed from properties will be ignored. For example, consider the following serializable `Person` type:

```
[Serializable]
public class Person
{
    // A public field.
    public bool isAlive = true;

    // A private field.
    private int personAge = 21;

    // Public property/private data.
    private string fName = string.Empty;
    public string FirstName
    {
        get { return fName; }
        set { fName = value; }
    }
}
```

If you processed the preceding with `BinaryFormatter` or `SoapFormatter`, you would find that the `isAlive`, `personAge`, and `fName` fields are saved into the selected stream. However, the `XmlSerializer` would *not* save the value of `personAge` because this piece of private data is not encapsulated by a public type property. If you wanted to persist the age of the person with the `XmlSerializer`, you would need to define the field publicly or encapsulate the private member using a public property.

Choosing a Serialization Formatter

After you configure your types to participate in the .NET serialization scheme by applying the necessary attributes, your next step is to choose which format (binary, SOAP, or XML) you should use when persisting your object's state. Each possibility is represented by the following classes:

- `BinaryFormatter`
- `SoapFormatter`
- `XmlSerializer`

The `BinaryFormatter` type serializes your object's state to a stream using a compact binary format. This type is defined within the `System.Runtime.Serialization.Formatters.Binary` namespace that is part of `mscorlib.dll`. If you want to gain access to this type, you can specify the following C# using directive:

```
// Gain access to the BinaryFormatter in mscorlib.dll.
using System.Runtime.Serialization.Formatters.Binary;
```

The `SoapFormatter` type persists an object's state as a SOAP message (the standard XML format for passing messages to/from a SOAP-based web service). This type is defined within the `System.Runtime.Serialization.Formatters.Soap` namespace, which is defined in a *separate assembly*. Thus, to format your object graph into a SOAP message, you must first set a reference to `System.Runtime.Serialization.Formatters.Soap.dll` using the Visual Studio Add Reference dialog box and then specify the following C# using directive:

```
// Must reference System.Runtime.Serialization.Formatters.Soap.dll.
using System.Runtime.Serialization.Formatters.Soap;
```

Finally, if you want to persist a tree of objects as an XML document, you can use the `XmlSerializer` type. To use this type, you need to specify that you are using the `System.Xml.Serialization` namespace and set a reference to the assembly `System.Xml.dll`. As luck would have it, all Visual Studio project templates automatically reference `System.Xml.dll`; therefore, all you need to do is use the following namespace:

```
// Defined within System.Xml.dll.
using System.Xml.Serialization;
```

The IFormatter and IRemotingFormatter Interfaces

Regardless of which formatter you choose to use, be aware that all of them derive directly from `System.Object`, so they do *not* share a common set of members from a serialization-centric base class. However, the `BinaryFormatter` and `SoapFormatter` types do support common members through the implementation of the `IFormatter` and `IRemotingFormatter` interfaces (strange as it might seem, the `XmlSerializer` implements neither).

`System.Runtime.Serialization.IFormatter` defines the core `Serialize()` and `Deserialize()` methods, which do the grunt work to move your object graphs into and out of a specific stream. Beyond these members, `IFormatter` defines the following few properties that the implementing type uses behind the scenes:

```
public interface IFormatter
{
    SerializationBinder Binder { get; set; }
    StreamingContext Context { get; set; }
    ISurrogateSelector SurrogateSelector { get; set; }
    object Deserialize(Stream serializationStream);
    void Serialize(Stream serializationStream, object graph);
}
```

The `System.Runtime.Remoting.Messaging.IRemotingFormatter` interface (which is leveraged internally by the .NET remoting layer) overloads the `Serialize()` and `Deserialize()` members into a manner more appropriate for distributed persistence. Note that `IRemotingFormatter` derives from the more general `IFormatter` interface.

```
public interface IRemotingFormatter : IFormatter
{
    object Deserialize(Stream serializationStream, HeaderHandler handler);
    void Serialize(Stream serializationStream, object graph, Header[] headers);
}
```

Although you might not need to interact directly with these interfaces for most of your serialization endeavors, recall that interface-based polymorphism allows you to hold an instance of `BinaryFormatter` or `SoapFormatter` using an `IFormatter` reference. Therefore, if you want to build a method that can serialize an object graph using either of these classes, you could write the following:

```
static void SerializeObjectGraph(IFormatter itfFormat,
                                Stream destStream, object graph)
{
    itfFormat.Serialize(destStream, graph);
}
```

Type Fidelity Among the Formatters

The most obvious difference among the three formatters is how the object graph is persisted to the stream (binary, SOAP, or XML). You should also be aware of a few more subtle points of distinction, specifically, how the formatters contend with *type fidelity*. When you use the `BinaryFormatter` type, it will persist not only the field data of the objects in the object graph but also each type's fully qualified name and the full name of the defining assembly (name, version, public key token, and culture). These extra points of data make the `BinaryFormatter` an ideal choice when you want to transport objects by value (e.g., as a full copy) across machine boundaries for .NET-centric applications.

The `SoapFormatter` persists traces of the assembly of origin through the use of an XML namespace. For example, recall the `Person` type earlier in this chapter. If this type were persisted as a SOAP message, you would find that the opening element of `Person` is qualified by the generated `xmlns`. Consider this partial definition, paying special attention to the `a1` XML namespace:

```
<a1:Person id="ref-1" xmlns:a1=
  "http://schemas.microsoft.com/clr/nsassem/SimpleSerialize/MyApp%2C%20
  Version%3D1.0.0.0%2C%20Culture%3Dneutral%2C%20PublicKeyToken%3Dnull">
  <isAlive>true</isAlive>
  <personAge>21</personAge>
  <fName id="ref-3">Mel</fName>
</a1:Person>
```

However, the `XmlSerializer` does *not* attempt to preserve full type fidelity; therefore, it does not record the type's fully qualified name or assembly of origin. This might seem like a limitation at first glance, but XML serialization is used by classic .NET web services, which can be called from clients on any platform (not just .NET). This means that there is no point serializing full .NET type metadata. Here is a possible XML representation of the `Person` type:

```
<?xml version="1.0"?>
<Person xmlns:xsi="http://www.w3.org/2001/XMLSchema-instance"
  xmlns:xsd="http://www.w3.org/2001/XMLSchema">
  <isAlive>true</isAlive>
  <PersonAge>21</PersonAge>
  <FirstName>Frank</FirstName>
</Person>
```

If you want to persist an object's state in a manner that can be used by any operating system (e.g., Windows, Mac OS X, and various Linux distributions), application framework (e.g., .NET, Java Enterprise Edition, and COM), or programming language, you do not want to maintain full type fidelity because you cannot assume all possible recipients can understand .NET-specific data types. Given this, `SoapFormatter` and `XmlSerializer` are ideal choices when you need to ensure as broad a reach as possible for the persisted tree of objects.

Serializing Objects Using the `BinaryFormatter`

You can use the `BinaryFormatter` type to illustrate how easy it is to persist an instance of the `JamesBondCar` to a physical file. Again, the two key methods of the `BinaryFormatter` type to be aware of are `Serialize()` and `Deserialize()`.

- `Serialize()`: Persists an object graph to a specified stream as a sequence of bytes
- `Deserialize()`: Converts a persisted sequence of bytes to an object graph

Assume you have created an instance of `JamesBondCar`, modified some state data, and want to persist your spy mobile into a `*.dat` file. Begin by creating the `*.dat` file itself. You can achieve this by creating an instance of the `System.IO.FileStream` type. At this point, you can create an instance of the `BinaryFormatter` and pass in the `FileStream` and object graph to persist. Consider the following `Main()` method:

```
// Be sure to import the System.Runtime.Serialization.Formatters.Binary
// and System.IO namespaces.
static void Main(string[] args)
{
    Console.WriteLine("***** Fun with Object Serialization *****\n");

    // Make a JamesBondCar and set state.
    JamesBondCar jbc = new JamesBondCar();
    jbc.canFly = true;
    jbc.canSubmerge = false;
    jbc.theRadio.stationPresets = new double[]{89.3, 105.1, 97.1};
    jbc.theRadio.hasTweeters = true;

    // Now save the car to a specific file in a binary format.
    SaveAsBinaryFormat(jbc, "CarData.dat");
    Console.ReadLine();
}
```

You implement the `SaveAsBinaryFormat()` method like this:

```
static void SaveAsBinaryFormat(object objGraph, string fileName)
{
    // Save object to a file named CarData.dat in binary.
    BinaryFormatter binFormat = new BinaryFormatter();

    using(Stream fStream = new FileStream(fileName,
        FileMode.Create, FileAccess.Write, FileShare.None))
    {
        binFormat.Serialize(fStream, objGraph);
    }
    Console.WriteLine("=> Saved car in binary format!");
}
```

The `BinaryFormatter.Serialize()` method is the member responsible for composing the object graph and moving the byte sequence to some `Stream`-derived type. In this case, the stream happens to be a physical file. You could also serialize your object types to any `Stream`-derived type, such as a memory location or network stream.

After you run your program, you can view the contents of the `CarData.dat` file that represents this instance of the `JamesBondCar` by navigating to the `\bin\Debug` folder of the current project. Figure 20-5 shows this file opened within Visual Studio.

| CarData.dat | CarCollection.xml | CarData.soap | |
|-------------|-------------------------|-------------------------|-------------------|
| 00000000 | 00 01 00 00 00 FF FF FF | FF 01 00 00 00 00 00 00 | |
| 00000010 | 00 0C 02 00 00 00 46 53 | 69 6D 70 6C 65 53 65 72 |FSimpleSer |
| 00000020 | 69 61 6C 69 7A 65 2C 20 | 56 65 72 73 69 6F 6E 3D | ialize, Version= |
| 00000030 | 31 2E 30 2E 30 2E 30 2C | 20 43 75 6C 74 75 72 65 | 1.0.0.0, Culture |
| 00000040 | 3D 6E 65 75 74 72 61 6C | 2C 20 50 75 62 6C 69 63 | =neutral, Public |
| 00000050 | 48 65 79 54 6F 68 65 6E | 3D 6E 75 6C 6C 05 01 00 | KeyToken=null... |
| 00000060 | 00 00 1C 53 69 6D 70 6C | 65 53 65 72 69 61 6C 69 | ...SimpleSeriali |
| 00000070 | 7A 65 2E 4A 61 6D 65 73 | 42 6F 6E 64 43 61 72 04 | ze.JamesBondCar. |
| 00000080 | 00 00 00 06 63 61 6E 46 | 6C 79 0B 63 61 6E 53 75 | ...canFly.canSu |
| 00000090 | 62 6D 65 72 67 65 08 74 | 68 65 52 61 64 69 6F 0B | bmerge.theRadio. |
| 000000a0 | 69 73 48 61 74 63 68 42 | 61 63 68 00 00 04 00 01 | isHatchBack..... |
| 000000b0 | 01 15 53 69 6D 70 6C 65 | 53 65 72 69 61 6C 69 7A | ..SimpleSerializ |
| 000000c0 | 65 2E 52 61 64 69 6F 02 | 00 00 00 01 02 00 00 00 | e.Radio..... |
| 000000d0 | 01 00 09 03 00 00 00 00 | 05 03 00 00 00 15 53 69 |Si |
| 000000e0 | 6D 70 6C 65 53 65 72 69 | 61 6C 69 7A 65 2E 52 61 | mpleSerialize.Ra |
| 000000f0 | 64 69 6F 03 00 00 00 0B | 68 61 73 54 77 65 65 74 | dio.....hasTweet |
| 00000100 | 65 72 73 0D 68 61 73 53 | 75 62 57 6F 6F 66 65 72 | ers.hasSubWoofers |
| 00000110 | 73 0E 73 74 61 74 69 6F | 6E 50 72 65 73 65 74 73 | s.stationPresets |
| 00000120 | 00 00 07 01 01 06 02 00 | 00 00 01 00 09 04 00 00 | |
| 00000130 | 00 0F 04 00 00 00 03 00 | 00 00 06 33 33 33 33 33 |33333 |
| 00000140 | 53 56 40 66 66 66 66 66 | 46 5A 40 66 66 66 66 66 | SV@fffffFZ@fffff |
| 00000150 | 46 58 40 0B | | FX@. |

Figure 20-5. JamesBondCar serialized using a BinaryFormatter

Deserializing Objects Using the BinaryFormatter

Now suppose you want to read the persisted JamesBondCar from the binary file back into an object variable. After you open CarData.dat programmatically (with the File.OpenRead() method), you can call the Deserialize() method of the BinaryFormatter. Be aware that Deserialize() returns a general System.Object type, so you need to impose an explicit cast, as shown here:

```
static void LoadFromBinaryFile(string fileName)
{
    BinaryFormatter binFormat = new BinaryFormatter();

    // Read the JamesBondCar from the binary file.
    using(Stream fStream = File.OpenRead(fileName))
    {
        JamesBondCar carFromDisk =
            (JamesBondCar)binFormat.Deserialize(fStream);
        Console.WriteLine("Can this car fly? : {0}", carFromDisk.canFly);
    }
}
```

Notice that when you call `Deserialize()`, you pass the `Stream`-derived type that represents the location of the persisted object graph. Once you cast the object back into the correct type, you will find the state data has been retained from the point at which you saved the object.

Serializing Objects Using the SoapFormatter

Your next choice of formatter is the `SoapFormatter` type, which serializes data in a proper SOAP envelope. In a nutshell, the Simple Object Access Protocol (SOAP) defines a standard process in which you can invoke methods in a platform- and OS-neutral manner.

Assuming you have added a reference to the `System.Runtime.Serialization.Formatters.Soap.dll` assembly (and imported the `System.Runtime.Serialization.Formatters.Soap` namespace), you can persist and retrieve a `JamesBondCar` as a SOAP message simply by replacing each occurrence of `BinaryFormatter` with `SoapFormatter`. Consider the following new method of the `Program` class, which serializes an object to a local file in a SOAP format:

```
// Be sure to import System.Runtime.Serialization.Formatters.Soap
// and reference System.Runtime.Serialization.Formatters.Soap.dll.
static void SaveAsSoapFormat (object objGraph, string fileName)
{
    // Save object to a file named CarData.soap in SOAP format.
    SoapFormatter soapFormat = new SoapFormatter();

    using(Stream fStream = new FileStream(fileName,
        FileMode.Create, FileAccess.Write, FileShare.None))
    {
        soapFormat.Serialize(fStream, objGraph);
    }
    Console.WriteLine("=> Saved car in SOAP format!");
}
```

As before, you use `Serialize()` and `Deserialize()` to move the object graph into and out of the stream. If you call this method from `Main()` and run the application, you can open the resulting `*.soap` file. Here you can locate the XML elements that mark the stateful values of the current `JamesBondCar`, as well as the relationship between the objects in the graph by using the `#ref` tokens (see Figure 20-6).

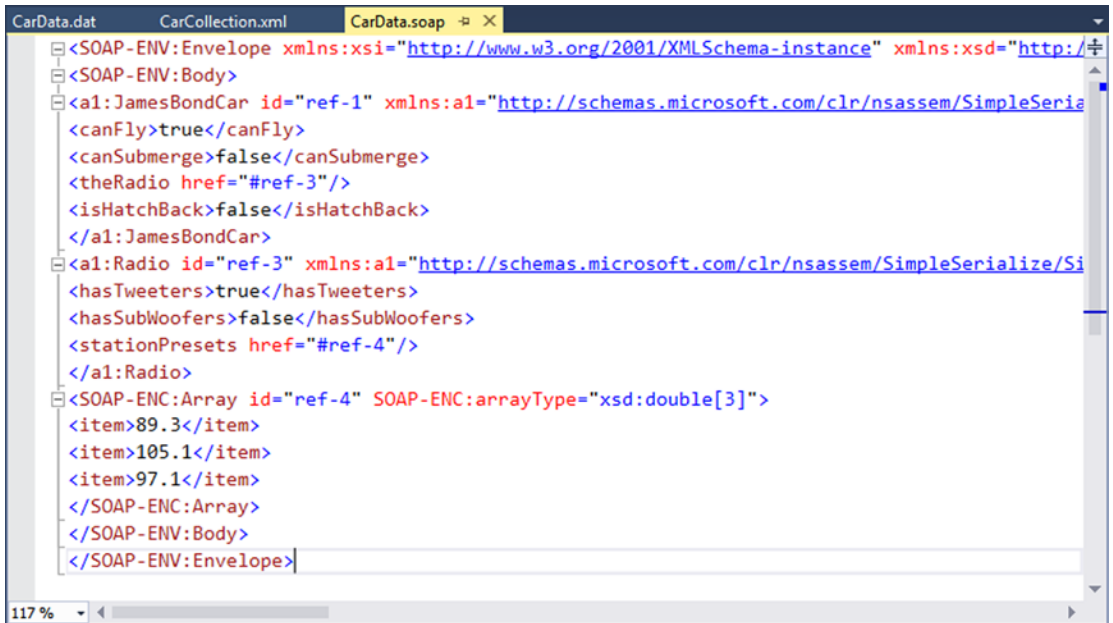

Figure 20-6. JamesBondCar serialized using a SoapFormatter

Serializing Objects Using the XmlSerializer

In addition to the SOAP and binary formatters, the System.Xml.dll assembly provides a third formatter, System.Xml.Serialization.XmlSerializer. You can use this formatter to persist the *public* state of a given object as pure XML, as opposed to XML data wrapped within a SOAP message. Working with this type is a bit different from working with the SoapFormatter or BinaryFormatter type. Consider the following code, which assumes you have imported the System.Xml.Serialization namespace:

```
static void SaveAsXmlFormat(object objGraph, string fileName)
{
    // Save object to a file named CarData.xml in XML format.
    XmlSerializer xmlFormat = new XmlSerializer(typeof(JamesBondCar));

    using(Stream fStream = new FileStream(fileName,
        FileMode.Create, FileAccess.Write, FileShare.None))
    {
        xmlFormat.Serialize(fStream, objGraph);
    }
    Console.WriteLine("=> Saved car in XML format!");
}
```

The key difference is that the `XmlSerializer` type requires you to specify type information that represents the class you want to serialize. If you were to look within the newly generated XML file (assuming you call this new method from within `Main()`), you would find the XML data shown here:

```
<?xml version="1.0"?>
<JamesBondCar xmlns:xsi="http://www.w3.org/2001/XMLSchema-instance"
xmlns:xsd="http://www.w3.org/2001/XMLSchema">
  <theRadio>
    <hasTweeters>true</hasTweeters>
    <hasSubWoofers>false</hasSubWoofers>
    <stationPresets>
      <double>89.3</double>
      <double>105.1</double>
      <double>97.1</double>
    </stationPresets>
    <radioID>XF-552RR6</radioID>
  </theRadio>
  <isHatchBack>false</isHatchBack>
  <canFly>true</canFly>
  <canSubmerge>false</canSubmerge>
</JamesBondCar>
```

■ **Note** The `XmlSerializer` demands that all serialized types in the object graph support a default constructor (so be sure to add it back if you define custom constructors). If this is not the case, you will receive an `InvalidOperationException` at runtime.

Controlling the Generated XML Data

If you have a background in XML technologies, you know that it is often critical to ensure the data within an XML document conforms to a set of rules that establish the *validity* of the data. Understand that a *valid* XML document does not have anything to do with the syntactic well-being of the XML elements (e.g., all opening elements must have a closing element). Rather, valid documents conform to agreed-upon formatting rules (e.g., field X must be expressed as an attribute and not a subelement), which are typically defined by an XML schema or document-type definition (DTD) file.

By default, `XmlSerializer` serializes all public fields/properties as XML elements, rather than as XML attributes. If you want to control how the `XmlSerializer` generates the resulting XML document, you can decorate types with any number of additional .NET attributes from the `System.Xml.Serialization` namespace. Table 20-12 documents some (but not all) of the .NET attributes that influence how XML data is encoded to a stream.

Table 20-12. *Select Attributes of the System.Xml.Serialization Namespace*

| .NET Attribute | Meaning in Life |
|----------------|---|
| [XmlAttribute] | You can use this .NET attribute on a public field or property in a class to tell XmlSerializer to serialize the data as an XML attribute (rather than as a subelement). |
| [XmlElement] | The field or property will be serialized as an XML element named as you so choose. |
| [XmlAttribute] | This attribute provides the element name of an enumeration member. |
| [XmlRoot] | This attribute controls how the root element will be constructed (namespace and element name). |
| [XmlText] | The property or field will be serialized as XML text (i.e., the content between the start tag and the end tag of the root element). |
| [XmlType] | This attribute provides the name and namespace of the XML type. |

This simple example illustrates how the field data of JamesBondCar is currently persisted as XML:

```
<?xml version="1.0" encoding="utf-8"?>
<JamesBondCar xmlns:xsi="http://www.w3.org/2001/XMLSchema-instance"
              xmlns:xsd="http://www.w3.org/2001/XMLSchema">
...
  <canFly>true</canFly>
  <canSubmerge>>false</canSubmerge>
</JamesBondCar>
```

If you want to specify a custom XML namespace that qualifies the JamesBondCar and encodes the canFly and canSubmerge values as XML attributes, you can do so by modifying the C# definition of JamesBondCar, like so:

```
[Serializable, XmlRoot(Namespace = "http://www.MyCompany.com")]
public class JamesBondCar : Car
{
  [XmlAttribute]
  public bool canFly;
  [XmlAttribute]
  public bool canSubmerge;
}
```

This yields the following XML document (note the opening <JamesBondCar> element):

```
<?xml version="1.0" ""?>
<JamesBondCar xmlns:xsi="http://www.w3.org/2001/XMLSchema-instance"
              xmlns:xsd="http://www.w3.org/2001/XMLSchema"
              canFly="true" canSubmerge="false"
              xmlns="http://www.MyCompany.com">
...
</JamesBondCar>
```

Of course, you can use many other .NET attributes to control how the XmlSerializer generates the resulting XML document. For full details, look up the System.Xml.Serialization namespace in the .NET Framework 4.6 SDK documentation.

Serializing Collections of Objects

Now that you have seen how to persist a single object to a stream, you're ready to examine how to save a set of objects. As you might have noticed, the `Serialize()` method of the `IFormatter` interface does not provide a way to specify an arbitrary number of objects as input (only a single `System.Object`). On a related note, the return value of `Deserialize()` is, again, a single `System.Object` (the same basic limitation holds true for `XmlSerializer`).

```
public interface IFormatter
{
    ...
    object Deserialize(Stream serializationStream);
    void Serialize(Stream serializationStream, object graph);
}
```

Recall that the `System.Object` represents a complete tree of objects. Given this, if you pass in an object that has been marked as `[Serializable]` and contains other `[Serializable]` objects, the entire set of objects is persisted in a single method call. As luck would have it, most of the types you find in the `System.Collections` and `System.Collections.Generic` namespaces have already been marked as `[Serializable]`. Therefore, if you would like to persist a set of objects, simply add the desired set to the container (such as a normal array, an `ArrayList` or a `List<T>`) and serialize the object to your stream of choice.

Now assume that you want to update the `JamesBondCar` class with a two-argument constructor so you can set a few pieces of state data (note that you add back the default constructor as required by the `XmlSerializer`).

```
[Serializable,
 XmlRoot(Namespace = "http://www.MyCompany.com")]
public class JamesBondCar : Car
{
    public JamesBondCar(bool skyWorthy, bool seaWorthy)
    {
        canFly = skyWorthy;
        canSubmerge = seaWorthy;
    }
    // The XmlSerializer demands a default constructor!
    public JamesBondCar(){}
    ...
}
```

With this, you can now persist any number of `JamesBondCars`.

```
static void SaveListOfCars()
{
    // Now persist a List<T> of JamesBondCars.
    List<JamesBondCar> myCars = new List<JamesBondCar>();
    myCars.Add(new JamesBondCar(true, true));
    myCars.Add(new JamesBondCar(true, false));
    myCars.Add(new JamesBondCar(false, true));
    myCars.Add(new JamesBondCar(false, false));
}
```

```

using(Stream fStream = new FileStream("CarCollection.xml",
    FileMode.Create, FileAccess.Write, FileShare.None))
{
    XmlSerializer xmlFormat = new XmlSerializer(typeof(List<JamesBondCar>));
    xmlFormat.Serialize(fStream, myCars);
}
Console.WriteLine("=> Saved list of cars!");
}

```

You use `XmlSerializer` here, so you are required to specify type information for each of the subobjects within the root object (`List<JamesBondCar>`, in this case). However, the logic would be even more straightforward if you were to use the `BinaryFormatter` or `SoapFormatter` type instead, as shown here:

```

static void SaveListOfCarsAsBinary()
{
    // Save ArrayList object (myCars) as binary.
    List<JamesBondCar> myCars = new List<JamesBondCar>();

    BinaryFormatter binFormat = new BinaryFormatter();
    using(Stream fStream = new FileStream("AllMyCars.dat",
        FileMode.Create, FileAccess.Write, FileShare.None))
    {
        binFormat.Serialize(fStream, myCars);
    }
    Console.WriteLine("=> Saved list of cars in binary!");
}

```

■ **Source Code** The `SimpleSerialize` application is included in the [Chapter 20](#) subdirectory.

Customizing the Soap/Binary Serialization Process

In a majority of cases, the default serialization scheme provided by the .NET platform will be exactly what you require. Simply apply the `[Serializable]` attribute to your related types and pass the tree of objects to your formatter of choice for processing. In some cases, however, you might want to become more involved with how a tree is constructed and handled during the serialization process. For example, perhaps you have a business rule that says all field data must be persisted using a particular format, or perhaps you need to add additional bits of data to the stream that do not map directly to fields in the object being persisted (e.g., timestamps and unique identifiers).

When you want to become more involved with the process of object serialization, the `System.Runtime.Serialization` namespace provides several types that allow you to do so. [Table 20-13](#) describes some of the core types you should be aware of.

Table 20-13. *System.Runtime.Serialization Namespace Core Types*

| Type | Meaning in Life |
|---------------------|---|
| ISerializable | You can implement this interface on a [Serializable] type to control its serialization and deserialization. |
| ObjectIDGenerator | This type generates IDs for members in an object graph. |
| [OnDeserialized] | This attribute allows you to specify a method that will be called immediately after the object has been deserialized. |
| [OnDeserializing] | This attribute allows you to specify a method that will be called before the deserialization process. |
| [OnSerialized] | This attribute allows you to specify a method that will be called immediately after the object has been serialized. |
| [OnSerializing] | This attribute allows you to specify a method that will be called before the serialization process. |
| [OptionalField] | This attribute allows you to define a field on a type that can be missing from the specified stream. |
| [SerializationInfo] | In essence, this class is a <i>property bag</i> that maintains name-value pairs representing the state of an object during the serialization process. |

A Deeper Look at Object Serialization

Before you examine various ways that you can customize the serialization process, you will find it helpful to take a deeper look at what takes place behind the scenes. When the `BinaryFormatter` serializes an object graph, it is in charge of transmitting the following information into the specified stream:

- The fully qualified name of the objects in the graph (e.g., `MyApp.JamesBondCar`)
- The name of the assembly defining the object graph (e.g., `MyApp.exe`)
- An instance of the `SerializationInfo` class that contains all stateful data maintained by the members in the object graph

During the deserialization process, the `BinaryFormatter` uses this same information to build an identical copy of the object, using the information extracted from the underlying stream. `SoapFormatter` uses a quite similar process.

■ **Note** Recall that the `XmlSerializer` does not persist a type's fully qualified name or the name of the defining assembly; this behavior helps keep the state of the object as mobile as possible. This type is concerned only with persisting exposed public data.

Beyond moving the required data into and out of a stream, formatters also analyze the members in the object graph for the following pieces of infrastructure:

- A check is made to determine whether the object is marked with the `[Serializable]` attribute. If the object is not, a `SerializationException` is thrown.
- If the object is marked `[Serializable]`, a check is made to determine whether the object implements the `ISerializable` interface. If this is the case, `GetObjectData()` is called on the object.
- If the object does not implement `ISerializable`, the default serialization process is used, serializing all fields not marked as `[NonSerialized]`.

In addition to determining whether the type supports `ISerializable`, formatters are also responsible for discovering whether the types in question support members that have been adorned with the `[OnSerializing]`, `[OnSerialized]`, `[OnDeserializing]`, or `[OnDeserialized]` attributes. You'll examine the role of these attributes in momentarily, but first you need to look at the role of `ISerializable`.

Customizing Serialization Using `ISerializable`

Objects that are marked `[Serializable]` have the option of implementing the `ISerializable` interface. Doing so lets you get “involved” with the serialization process and perform any pre- or post-data formatting.

The `ISerializable` interface is quite simple, given that it defines only a single method, `GetObjectData()`.

```
// When you wish to tweak the serialization process,  
// implement ISerializable.  
public interface ISerializable  
{  
    void GetObjectData(SerializationInfo info,  
        StreamingContext context);  
}
```

The `GetObjectData()` method is called automatically by a given formatter during the serialization process. The implementation of this method populates the incoming `SerializationInfo` parameter with a series of name-value pairs that (typically) map to the field data of the object being persisted. `SerializationInfo` defines numerous variations on the overloaded `AddValue()` method, as well as a small set of properties that allow the type to get and set the type's name, defining assembly, and member count. Here is a partial snapshot:

```
public sealed class SerializationInfo  
{  
    public SerializationInfo(Type type, IFormatterConverter converter);  
    public string AssemblyName { get; set; }  
    public string FullTypeName { get; set; }  
    public int MemberCount { get; }  
    public void AddValue(string name, short value);  
    public void AddValue(string name, ushort value);  
    public void AddValue(string name, int value);  
    ...  
}
```

Types that implement the `ISerializable` interface must also define a special constructor that takes the following signature:

```
// You must supply a custom constructor with this signature
// to allow the runtime engine to set the state of your object.
[Serializable]
class SomeClass : ISerializable
{
    protected SomeClass (SerializationInfo si, StreamingContext ctx) {...}
    ...
}
```

Notice that the visibility of this constructor is set as *protected*. This is permissible because the formatter will have access to this member, regardless of its visibility. These special constructors tend to be marked as *protected* (or *private* for that matter) to ensure that the casual object user can never create an object in this manner. The first parameter of this constructor is an instance of the `SerializationInfo` type (which you've seen previously).

The second parameter of this special constructor is a `StreamingContext` type, which contains information regarding the source of the bits. The most informative member of `StreamingContext` is the `State` property, which represents a value from the `StreamingContextStates` enumeration. The values of this enumeration represent the basic composition of the current stream.

Unless you intend to implement some low-level custom remoting services, you will seldom need to deal with this enumeration directly. Nevertheless, here are the possible names of the `StreamingContextStates` enum (consult the .NET Framework 4.6 SDK documentation for full details):

```
public enum StreamingContextStates
{
    CrossProcess,
    CrossMachine,
    File,
    Persistence,
    Remoting,
    Other,
    Clone,
    CrossAppDomain,
    All
}
```

Now let's look at how to customize the serialization process using `ISerializable`. Assume you have a new Console Application project (named `CustomSerialization`) that defines a class type containing two points of string data. Also assume that you must ensure that the string objects are serialized to the stream in all uppercase and deserialized from the stream in lowercase. To account for such rules, you could implement `ISerializable` like this (be sure to import the `System.Runtime.Serialization` namespace):

```
[Serializable]
class StringData : ISerializable
{
    private string dataItemOne = "First data block";
    private string dataItemTwo= "More data";
```

```

public StringData(){
protected StringData(SerializationInfo si, StreamingContext ctx)
{
    // Rehydrate member variables from stream.
    dataItemOne = si.GetString("First_Item").ToLower();
    dataItemTwo = si.GetString("dataItemTwo").ToLower();
}

void ISerializable.GetObjectData(SerializationInfo info, StreamingContext ctx)
{
    // Fill up the SerializationInfo object with the formatted data.
    info.AddValue("First_Item", dataItemOne.ToUpper());
    info.AddValue("dataItemTwo", dataItemTwo.ToUpper());
}
}

```

Notice that when you fill the `SerializationInfo` type with the `GetObjectData()` method, you are *not* required to name the data points identically to the type's internal member variables. This can obviously be helpful if you need to further decouple the type's data from the persisted format. Be aware, however, that you will need to obtain the values from the special, protected constructor using the same names assigned within `GetObjectData()`.

To test your customization, assume that you want to persist an instance of `MyStringData` using a `SoapFormatter` (so update your assembly references and imports accordingly), as follows:

```

static void Main(string[] args)
{
    Console.WriteLine("***** Fun with Custom Serialization *****");

    // Recall that this type implements ISerializable.
    StringData myData = new StringData();

    // Save to a local file in SOAP format.
    SoapFormatter soapFormat = new SoapFormatter();
    using(Stream fStream = new FileStream("MyData.soap",
        FileMode.Create, FileAccess.Write, FileShare.None))
    {
        soapFormat.Serialize(fStream, myData);
    }
    Console.ReadLine();
}

```

When you view the resulting `*.soap` file, you will see that the string fields have been persisted in uppercase, as so:

```

<SOAP-ENV:Envelope xmlns:xsi="http://www.w3.org/2001/XMLSchema-instance"
  xmlns:xsd="http://www.w3.org/2001/XMLSchema"
  xmlns:SOAP-ENC="http://schemas.xmlsoap.org/soap/encoding/"
  xmlns:SOAP-ENV="http://schemas.xmlsoap.org/soap/envelope/"
  xmlns:clr="http://schemas.microsoft.com/soap/encoding clr/1.0"
  SOAP-ENV:encodingStyle="http://schemas.xmlsoap.org/soap/encoding/">
<SOAP-ENV:Body>

```

```

<a1:StringData id="ref-1" ...>
  <First_Item id="ref-3">FIRST DATA BLOCK</First_Item>
  <dataItemTwo id="ref-4">MORE DATA</dataItemTwo>
</a1:StringData>
</SOAP-ENV:Body>

</SOAP-ENV:Envelope>

```

Customizing Serialization Using Attributes

Although implementing the `ISerializable` interface is one way to customize the serialization process, the preferred way to customize the serialization process is to define methods that are attributed with any of the new serialization-centric attributes: `[OnSerializing]`, `[OnSerialized]`, `[OnDeserializing]`, or `[OnDeserialized]`. Using these attributes is less cumbersome than implementing `ISerializable` because you do not need to interact manually with an incoming `SerializationInfo` parameter. Instead, you can modify your state data directly, while the formatter operates on the type.

■ **Note** You can find these serialization attributes defined in the `System.Runtime.Serialization` namespace.

When you define method decorated with these attributes, you must define the methods so they receive a `StreamingContext` parameter and return nothing (otherwise, you will receive a runtime exception). Note that you are not required to account for each of the serialization-centric attributes, and you can simply contend with the stages of serialization you want to intercept. The following snippet illustrates this. Here, a new `[Serializable]` type has the same requirements as `StringData`, but this time you account for using the `[OnSerializing]` and `[OnDeserialized]` attributes:

[Serializable]

```

class MoreData
{
  private string dataItemOne = "First data block";
  private string dataItemTwo = "More data";

```

[OnSerializing]

```

private void OnSerializing(StreamingContext context)
{
  // Called during the serialization process.
  dataItemOne = dataItemOne.ToUpper();
  dataItemTwo = dataItemTwo.ToUpper();
}

```

[OnDeserialized]

```

private void OnDeserialized(StreamingContext context)
{
  // Called when the deserialization process is complete.
  dataItemOne = dataItemOne.ToLower();
  dataItemTwo = dataItemTwo.ToLower();
}
}

```

If you were to serialize this new type, you would again find that the data has been persisted as uppercase and deserialized as lowercase.

■ **Source Code** You can find the CustomSerialization project in the Chapter 20 subdirectory.

With this example behind you, your exploration of the core details of object serialization services, including various ways to customize the process, is complete. As you have seen, the serialization and deserialization process makes it easy to persist large amounts of data, and it can be less labor-intensive than working with the various reader/writer classes of the `System.IO` namespace.

Summary

You began this chapter by examining the use of the `Directory(Info)` and `File(Info)` types. As you learned, these classes allow you to manipulate a physical file or directory on your hard drive. Next, you examined a number of classes derived from the abstract `Stream` class. Given that `Stream`-derived types operate on a raw stream of bytes, the `System.IO` namespace provides numerous reader/writer types (e.g., `StreamWriter`, `StringWriter`, and `BinaryWriter`) that simplify the process. Along the way, you also checked out the functionality provided by `DriveType`, learned how to monitor files using the `FileSystemWatcher` type, and saw how to interact with streams in an asynchronous manner.

This chapter also introduced you to the topic of object serialization services. As you have seen, the .NET platform uses an object graph to account for the full set of related objects that you want to persist to a stream. As long as each member in the object graph has been marked with the `[Serializable]` attribute, the data is persisted using your format of choice (binary or SOAP).

You also learned that it is possible to customize the out-of-the-box serialization process using two possible approaches. First, you learned how to implement the `ISerializable` interface (and support a special private constructor), which enables you to become more involved with how formatters persist the supplied data. Second, you learned about a set of .NET attributes that simplify the process of custom serialization. All you need to do is apply the `[OnSerializing]`, `[OnSerialized]`, `[OnDeserializing]`, or `[OnDeserialized]` attribute on members that take a `StreamingContext` parameter, and the formatters will invoke them accordingly.

CHAPTER 21



ADO.NET Part I: The Connected Layer

The .NET platform defines a number of namespaces that allow you to interact with relational database systems. Collectively speaking, these namespaces are known as *ADO.NET*. In this chapter, you'll learn about the overall role of ADO.NET and the core types and namespaces, and then you'll move on to the topic of ADO.NET data providers. The .NET platform supports numerous data providers (both provided as part of the .NET Framework and available from third-party sources), each of which is optimized to communicate with a specific database management system (e.g., Microsoft SQL Server, Oracle, and MySQL).

After you understand the common functionality provided by various data providers, you will then look at the data provider factory pattern. As you will see, using types within the `System.Data.Common` namespace (and a related `App.config` file), you can build a single code base that can dynamically pick and choose the underlying data provider without the need to recompile or redeploy the application's code base.

Perhaps most importantly, this chapter will give you the chance to build a custom data access library assembly (`AutoLotDAL.dll`) that encapsulates various database operations performed on a custom database named `AutoLot`. Finally, you will wrap things up by examining the topic of database transactions.

■ **Note** You will expand the capabilities of this library in Chapter 22 and then create it from scratch using Entity Framework (EF) in Chapter 23. Why create it twice? Even though object-relational mapping frameworks (ORMs) like Entity Framework make it much simpler (and faster) to create data access code, ORMs still use ADO.NET as the core data access technology. A solid understanding of how ADO.NET works is vital when troubleshooting an issue with your data access, especially when it was created by a framework and not written by you. Also, you will encounter scenarios that aren't solved by EF (such as executing a `SQL BulkCopy`), and you will need to know ADO.NET to solve those issues.

A High-Level Definition of ADO.NET

If you have a background in Microsoft's previous COM-based data access model (Active Data Objects [ADO]) and are just starting to work with the .NET platform, you need to understand that ADO.NET has little to do with ADO beyond the letters *A*, *D*, and *O*. While it is true that there is some relationship between the two systems (e.g., each has the concept of connection and command objects), some familiar ADO types (e.g., the Recordset) no longer exist. Furthermore, you can find many new ADO.NET types that have no direct equivalent under classic ADO (e.g., the data adapter).

ADO.NET was built with the disconnected world in mind. Prior to the wider adoption of ORMs, this was typically accomplished using DataSets. DataSets represent a local copy of any number of related data tables, each of which contains a collection of rows and column. Using a DataSet, the calling assembly (such as a web page or desktop executable) is able to manipulate and update a DataSet's contents while disconnected from the data source and send any modified data back for processing using a related *data adapter*.

■ **Note** ORMs don't use DataSets but rather lists of plain old C# objects (also called POCOs). This chapter and the next detail how ADO.NET works. This foundation is important, even if you plan on moving straight to an ORM such as Entity Framework. EF, NHibernate, and the other ORMs in the .NET world are built in top of ADO.NET, so if you need to work through an issue where your code doesn't seem to be working the way you expect it to, knowing how ADO.NET works is a significant plus. The subsequent chapters use a data access library developed using EF.

From a programmatic point of view, the bulk of ADO.NET is represented by a core assembly named System.Data.dll. Within this binary, you find a good number of namespaces (see Figure 21-1), many of which represent the types of a particular ADO.NET data provider (defined momentarily).

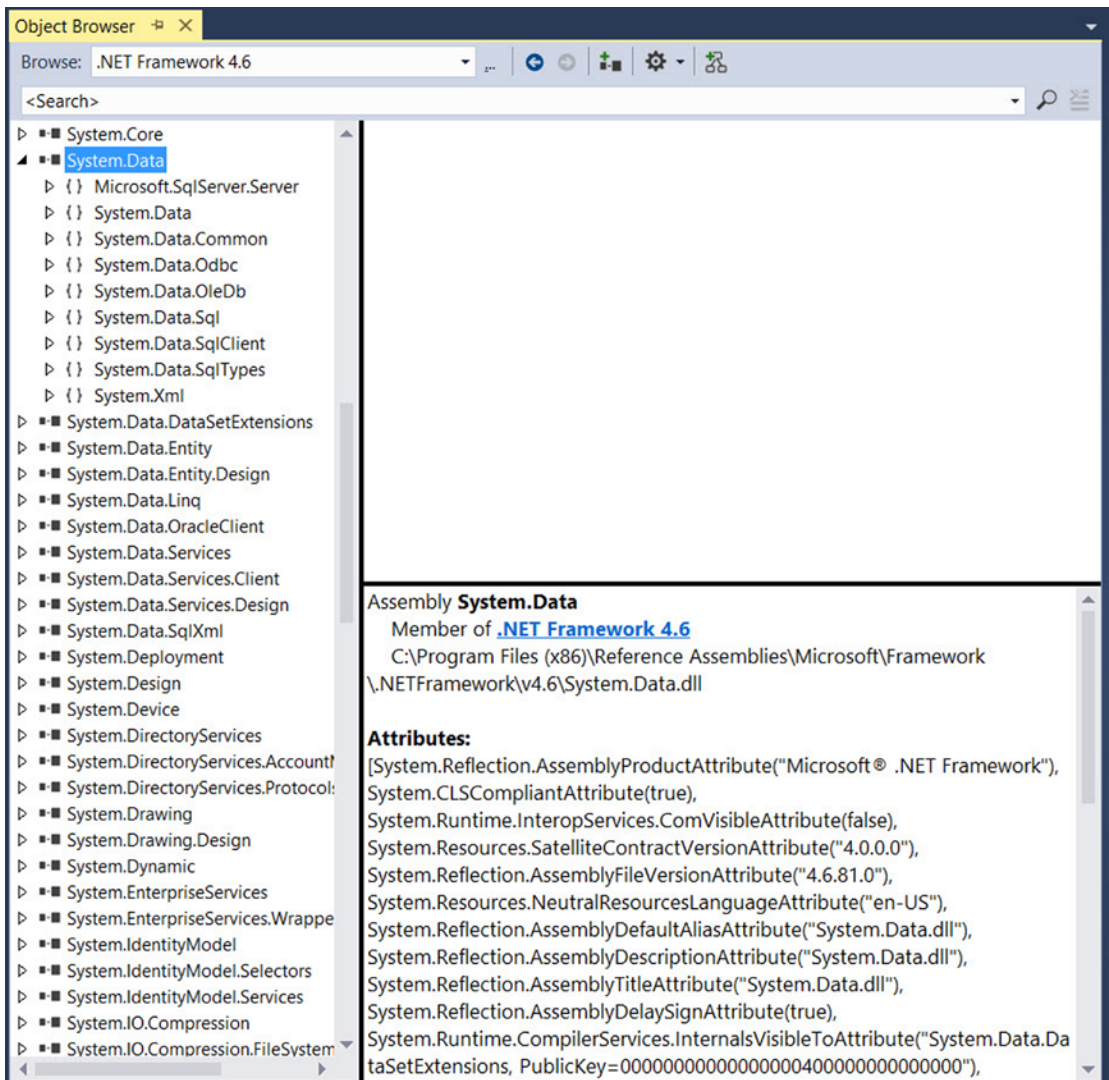

Figure 21-1. *System.Data.dll* is the core ADO.NET assembly

It turns out most Visual Studio project templates automatically reference this key data access assembly. You should also understand that there are other ADO.NET-centric assemblies beyond *System.Data.dll*, which you might need to reference manually in your current project using the Add Reference dialog box.

The Three Faces of ADO.NET

You can use the ADO.NET libraries in three conceptually unique manners: connected, disconnected, or through an ORM, such as Entity Framework. When you use the *connected layer* (the subject of this chapter), your code base explicitly connects to and disconnects from the underlying data store. When you use ADO.NET in this manner, you typically interact with the data store using connection objects, command objects, and data reader objects.

The *disconnected layer* (you will learn more about this in Chapter 22) allows you to manipulate a set of `DataTable` objects (contained within a `DataSet`) that functions as a client-side copy of the external data. When you obtain a `DataSet` using a related data adapter object, the connection is automatically opened and closed on your behalf. As you would guess, this approach helps free up connections for other callers quickly and goes a long way toward increasing the scalability of your systems.

After a caller receives a `DataSet`, it is able to traverse and manipulate the contents without incurring the cost of network traffic. Also, if the caller wants to submit the changes back to the data store, the data adapter (in conjunction with a set of SQL statements) is used to update the data source; at this point the connection is reopened for the database updates to occur and then closed again immediately.

Finally, in Chapter 23, you will be introduced to a data access API termed the *Entity Framework* (EF). Using EF, you are able to interact with a relational database using client-side objects that encapsulate a number of low-level database specifics from view. As well, the EF programming model allows you to interact with relational databases using strongly typed LINQ queries, using the grammar of LINQ to Entities.

Understanding ADO.NET Data Providers

ADO.NET does not provide a single set of objects that communicate with multiple database management systems (DBMSs). Rather, ADO.NET supports multiple *data providers*, each of which is optimized to interact with a specific DBMS. The first benefit of this approach is that you can program a specific data provider to access any unique features of a particular DBMS. The second benefit is that a specific data provider can connect directly to the underlying engine of the DBMS in question without an intermediate mapping layer standing between the tiers.

Simply put, a data provider is a set of types defined in a given namespace that understand how to communicate with a specific type of data source. Regardless of which data provider you use, each defines a set of class types that provide core functionality. Table 21-1 documents some of the core common types, their base class (all defined in the `System.Data.Common` namespace), and the key interfaces (each is defined in the `System.Data` namespace) they implement.

Table 21-1. *The Core Objects of an ADO.NET Data Provider*

| Type of Object | Base Class | Relevant Interfaces | Meaning in Life |
|--------------------------|----------------------------|--|--|
| Connection | <code>DbConnection</code> | <code>IDbConnection</code> | Provides the ability to connect to and disconnect from the data store. Connection objects also provide access to a related transaction object. |
| Command | <code>DbCommand</code> | <code>IDbCommand</code> | Represents a SQL query or a stored procedure. Command objects also provide access to the provider's data reader object. |
| <code>DataReader</code> | <code>DbDataReader</code> | <code>IDataReader</code> , <code>IDataRecord</code> | Provides forward-only, read-only access to data using a server-side cursor. |
| <code>DataAdapter</code> | <code>DbDataAdapter</code> | <code>IDataAdapter</code> , <code>IDbDataAdapter</code> | Transfers <code>DataSets</code> between the caller and the data store. Data adapters contain a connection and a set of four internal command objects used to select, insert, update, and delete information from the data store. |
| Parameter | <code>DbParameter</code> | <code>IDataParameter</code> , <code>IDbDataParameter</code> | Represents a named parameter within a parameterized query. |
| Transaction | <code>DbTransaction</code> | <code>IDbTransaction</code> | Encapsulates a database transaction. |

Although the specific names of these core classes will differ among data providers (e.g., `SqlConnection` versus `OdbcConnection`), each class derives from the same base class (`DbConnection`, in the case of connection objects) that implements identical interfaces (e.g., `IDbConnection`). Given this, you would be correct to assume that after you learn how to work with one data provider, the remaining providers prove quite straightforward.

■ **Note** When you refer to a connection object under ADO.NET, you're actually referring to a specific `DbConnection`-derived type; there is no class literally named *Connection*. The same idea holds true for a *command object*, *data adapter object*, and so forth. As a naming convention, the objects in a specific data provider are prefixed with the name of the related DBMS (e.g., `SqlConnection`, `SqlConnection`, and `SqlDataReader`).

Figure 21-2 shows the big picture behind ADO.NET data providers. Note how the diagram illustrates that the *Client Assembly* can literally be any type of .NET application: console program, Windows Forms application, WPF application, ASP.NET web page, WCF service, Web API service, .NET code library, and so on.

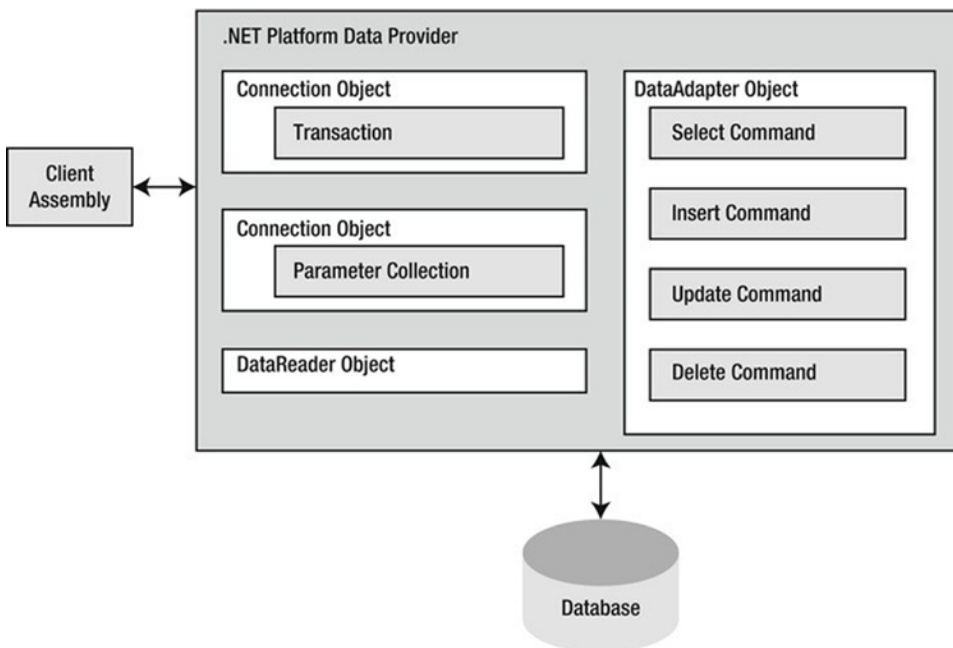

Figure 21-2. ADO.NET data providers provide access to a given DBMS

A data provider will supply you with other types beyond the objects shown in Figure 21-2; however, these core objects define a common baseline across all data providers.

The Microsoft-Supplied ADO.NET Data Providers

Microsoft's .NET distribution ships with numerous data providers, including a provider for Oracle, SQL Server, and OLE DB/ODBC-style connectivity. Table 21-2 documents the namespace and containing assembly for each Microsoft ADO.NET data provider.

Table 21-2. *Microsoft ADO.NET Data Providers*

| Data Provider | Namespace | Assembly |
|------------------------------|-----------------------|-----------------|
| OLE DB | System.Data.OleDb | System.Data.dll |
| Microsoft SQL Server LocalDb | System.Data.SqlClient | System.Data.dll |
| ODBC | System.Data.Odbc | System.Data.dll |

■ **Note** While an Oracle provider is still being shipped with the .NET Framework, the recommendation is to use the Oracle-supplied Oracle Developer Tools for Visual Studio. In fact, if you open Server Explorer and select New Connection and then Oracle Database, Visual Studio will tell you to use the Oracle Data Tools and provide a link where they can be downloaded.

There is no specific data provider that maps directly to the Jet engine (and, therefore, Microsoft Access). If you want to interact with an Access data file, you can do so using the OLE DB or ODBC data provider.

The OLE DB data provider, which is composed of the types defined in the `System.Data.OleDb` namespace, allows you to access data located in any data store that supports the classic COM-based OLE DB protocol. You can use this provider to communicate with any OLE DB-compliant database simply by tweaking the Provider segment of your connection string.

However, the OLE DB provider interacts with various COM objects behind the scenes, which can affect the performance of your application. By and large, the OLE DB data provider is useful only if you interact with a DBMS that does not define a specific .NET data provider. However, given that these days any DBMS worth its salt should have a custom ADO.NET data provider for download, you should consider `System.Data.OleDb` a legacy namespace that has little use in the .NET 4.6 world. (This is even more the case with the advent of the data provider factory model introduced under .NET 2.0, which you will learn about shortly.)

■ **Note** There is one case in which using the types of `System.Data.OleDb` is necessary: when you need to communicate with Microsoft SQL Server version 6.5 or earlier. The `System.Data.SqlClient` namespace can communicate only with Microsoft SQL Server version 7.0 or higher.

The Microsoft SQL Server data provider offers direct access to Microsoft SQL Server data stores— and *only* SQL Server data stores (version 7.0 and greater). The `System.Data.SqlClient` namespace contains the types used by the SQL Server provider and offers the same basic functionality as the OLE DB provider. The key difference is that the SQL Server provider bypasses the OLE DB layer and gives numerous performance benefits. The Microsoft SQL Server data provider also allows you to gain access to the unique features of this particular DBMS.

The remaining Microsoft-supplied provider (`System.Data.Odbc`) provides access to ODBC connections. The ODBC types defined within the `System.Data.Odbc` namespace are typically useful only if you need to communicate with a given DBMS for which there is no custom .NET data provider. This is true because ODBC is a widespread model that provides access to a number of data stores.

A Word Regarding `System.Data.OracleClient.dll`

Earlier versions of the .NET platform shipped with an assembly named `System.Data.OracleClient.dll`, which, as the name suggests, offered a data provider to communicate with Oracle databases. As of .NET 4.0, however, this assembly has been marked as obsolete and will eventually be deprecated. The Oracle client is still included in .NET 4.6, but it would be wise to not expect it to be included forever.

At first glance, this might cause you to fear that ADO.NET is slowly becoming focused squarely on Microsoft-centric data stores; however, this is not the case. Oracle provides its own custom .NET assembly, which follows the same overall design guidelines as the data providers provided by Microsoft. If you need to obtain this .NET assembly, you can visit following web site:

<http://www.oracle.com/technetwork/topics/dotnet/index-085163.html>

Obtaining Third-Party ADO.NET Data Providers

In addition to the data providers that ship from Microsoft (as well as Oracle's custom .NET library), numerous third-party data providers exist for various open source and commercial databases. While you will most likely be able to obtain an ADO.NET data provider directly from the database vendor, you should be aware of the following site:

<https://msdn.microsoft.com/en-us/library/dd363565.aspx>

This web site is one of many sites that document each known ADO.NET data provider and provide links for more information and downloads. Here, you will find numerous ADO.NET providers, including SQLite, IBM DB2, MySQL, Postgres, Sybase, and many others.

Given the large number of ADO.NET data providers, the examples in this book will use the Microsoft SQL Server data provider (`System.Data.SqlClient.dll`). Recall that this provider allows you to communicate with Microsoft SQL Server version 7.0 and higher, including SQL Server Express Edition and LocalDb. If you intend to use ADO.NET to interact with another DBMS, you should have no problem doing so once you understand the material presented in the pages that follow.

Additional ADO.NET Namespaces

In addition to the .NET namespaces that define the types of a specific data provider, the .NET base class libraries provide a number of additional ADO.NET-centric namespaces, some of which you can see in Table 21-3 (again, Chapter 23 will address the assemblies and namespaces specific to Entity Framework).

Table 21-3. *Select Additional ADO.NET-Centric Namespaces*

| Namespace | Meaning in Life |
|----------------------------|--|
| Microsoft.SqlServer.Server | This namespace provides types that facilitate CLR and SQL Server 2005 and later integration services. |
| System.Data | This namespace defines the core ADO.NET types used by all data providers, including common interfaces and numerous types that represent the disconnected layer (e.g., DataSet and DataTable). |
| System.Data.Common | This namespace contains types shared between all ADO.NET data providers, including the common abstract base classes. |
| System.Data.Sql | This namespace contains types that allow you to discover Microsoft SQL Server instances installed on the current local network. |
| System.Data.SqlTypes | This namespace contains native data types used by Microsoft SQL Server. You can always use the corresponding CLR data types, but the SqlTypes are optimized to work with SQL Server (e.g., if your SQL Server database contains an integer value, you can represent it using either int or SqlTypes.SqlInt32). |

Note that this chapter does not examine every type within every ADO.NET namespace (that task would require a large book all by itself); however, it is quite important that you understand the types within the System.Data namespace.

The Types of the System.Data Namespace

Of all the ADO.NET namespaces, System.Data is the lowest common denominator. You cannot build ADO.NET applications without specifying this namespace in your data access applications. This namespace contains types that are shared among all ADO.NET data providers, regardless of the underlying data store. In addition to a number of database-centric exceptions (e.g., `NotNullAllowedException`, `RowNotInTableException`, and `MissingPrimaryKeyException`), System.Data contains types that represent various database primitives (e.g., tables, rows, columns, and constraints), as well as the common interfaces implemented by data provider objects. Table 21-4 lists some of the core types you should be aware of.

Table 21-4. Core Members of the System.Data Namespace

| Type | Meaning in Life |
|-----------------|--|
| Constraint | Represents a constraint for a given DataColumn object |
| DataColumn | Represents a single column within a DataTable object |
| DataRelation | Represents a parent-child relationship between two DataTable objects |
| DataRow | Represents a single row within a DataTable object |
| DataSet | Represents an in-memory cache of data consisting of any number of interrelated DataTable objects |
| DataTable | Represents a tabular block of in-memory data |
| DataTableReader | Allows you to treat a DataTable as a fire-hose cursor (forward only, read-only data access) |
| DataView | Represents a customized view of a DataTable for sorting, filtering, searching, editing, and navigation |
| IDataAdapter | Defines the core behavior of a data adapter object |
| IDataParameter | Defines the core behavior of a parameter object |
| IDataReader | Defines the core behavior of a data reader object |
| SqlCommand | Defines the core behavior of a command object |
| SqlDataAdapter | Extends IDataAdapter to provide additional functionality of a data adapter object |
| SqlTransaction | Defines the core behavior of a transaction object |

You use the vast majority of the classes within System.Data when programming against the disconnected layer of ADO.NET. In the next chapter, you will get to know the details of the DataSet and its related cohorts (e.g., DataTable, DataRelation, and DataRow) and how to use them (and a related data adapter) to represent and manipulate client-side copies of remote data.

However, your next task is to examine the core interfaces of System.Data at a high level; this can help you understand the common functionality offered by any data provider. You will also learn specific details throughout this chapter; however, for now it's best to focus on the overall behavior of each interface type.

The Role of the IDbConnection Interface

The IDbConnection type is implemented by a data provider's *connection object*. This interface defines a set of members used to configure a connection to a specific data store. It also allows you to obtain the data provider's transaction object. Here is the formal definition of IDbConnection:

```
public interface IDbConnection : IDisposable
{
    string ConnectionString { get; set; }
    int ConnectionTimeout { get; }
    string Database { get; }
    ConnectionState State { get; }

    IDbTransaction BeginTransaction();
    IDbTransaction BeginTransaction(IsolationLevel il);
}
```

```

void ChangeDatabase(string databaseName);
void Close();
IDbCommand CreateCommand();
void Open();
}

```

■ **Note** Like many other types in the .NET base class libraries, the `Close()` method is functionally equivalent to calling the `Dispose()` method directly or indirectly within C# by using scope (see Chapter 13).

The Role of the IDbTransaction Interface

The overloaded `BeginTransaction()` method defined by `IDbConnection` provides access to the provider's *transaction object*. You can use the members defined by `IDbTransaction` to interact programmatically with a transactional session and the underlying data store.

```

public interface IDbTransaction : IDisposable
{
    IDbConnection Connection { get; }
    IsolationLevel IsolationLevel { get; }

    void Commit();
    void Rollback();
}

```

The Role of the IDbCommand Interface

Next up is the `IDbCommand` interface, which will be implemented by a data provider's *command object*. Like other data access object models, command objects allow programmatic manipulation of SQL statements, stored procedures, and parameterized queries. Command objects also provide access to the data provider's data reader type through the overloaded `ExecuteReader()` method.

```

public interface IDbCommand : IDisposable
{
    IDbConnection Connection { get; set; }
    IDbTransaction Transaction { get; set; }
    string CommandText { get; set; }
    int CommandTimeout { get; set; }
    CommandType CommandType { get; set; }
    IDataParameterCollection Parameters { get; }
    UpdateRowSource UpdatedRowSource { get; set; }

    void Prepare();
    void Cancel();
    IDbDataParameter CreateParameter();
}

```



```

int ExecuteNonQuery();
IDataReader ExecuteReader();
IDataReader ExecuteReader(CommandBehavior behavior);
object ExecuteScalar();
}

```

The Role of the IDbDataParameter and IDataParameter Interfaces

Notice that the `Parameters` property of `IDbCommand` returns a strongly typed collection that implements `IDataParameterCollection`. This interface provides access to a set of `IDbDataParameter`-compliant class types (e.g., parameter objects).

```

public interface IDbDataParameter : IDataParameter
{
    byte Precision { get; set; }
    byte Scale { get; set; }
    int Size { get; set; }
}

```

`IDbDataParameter` extends the `IDataParameter` interface to obtain the following additional behaviors:

```

public interface IDataParameter
{
    DbType DbType { get; set; }
    ParameterDirection Direction { get; set; }
    bool IsNullable { get; }
    string ParameterName { get; set; }
    string SourceColumn { get; set; }
    DataRowVersion SourceVersion { get; set; }
    object Value { get; set; }
}

```

As you will see, the functionality of the `IDbDataParameter` and `IDataParameter` interfaces allows you to represent parameters within a SQL command (including stored procedures) through specific ADO.NET parameter objects, rather than through hard-coded string literals.

The Role of the IDbDataAdapter and IDataAdapter Interfaces

You use *data adapters* to push and pull `DataSets` to and from a given data store. The `IDbDataAdapter` interface defines the following set of properties that you can use to maintain the SQL statements for the related select, insert, update, and delete operations:

```

public interface IDbDataAdapter : IDataAdapter
{
    IDbCommand SelectCommand { get; set; }
    IDbCommand InsertCommand { get; set; }
    IDbCommand UpdateCommand { get; set; }
    IDbCommand DeleteCommand { get; set; }
}

```

In addition to these four properties, an ADO.NET data adapter also picks up the behavior defined in the base interface, `IDataAdapter`. This interface defines the key function of a data adapter type: the ability to transfer `DataSets` between the caller and underlying data store using the `Fill()` and `Update()` methods. The `IDataAdapter` interface also allows you to map database column names to more user-friendly display names with the `TableMappings` property.

```
public interface IDataAdapter
{
    MissingMappingAction MissingMappingAction { get; set; }
    MissingSchemaAction MissingSchemaAction { get; set; }
    ITableMappingCollection TableMappings { get; }

    DataTable[] FillSchema(DataSet dataSet, SchemaType schemaType);
    int Fill(DataSet dataSet);
    IDataParameter[] GetFillParameters();
    int Update(DataSet dataSet);
}
```

The Role of the `IDataReader` and `IDataRecord` Interfaces

The next key interface to be aware of is `IDataReader`, which represents the common behaviors supported by a given data reader object. When you obtain an `IDataReader`-compatible type from an ADO.NET data provider, you can iterate over the result set in a forward-only, read-only manner.

```
public interface IDataReader : IDisposable, IDataRecord
{
    int Depth { get; }
    bool IsClosed { get; }
    int RecordsAffected { get; }

    void Close();
    DataTable GetSchemaTable();
    bool NextResult();
    bool Read();
}
```

Finally, `IDataReader` extends `IDataRecord`, which defines many members that allow you to extract a strongly typed value from the stream, rather than casting the generic `System.Object` retrieved from the data reader's overloaded indexer method. Here is the `IDataRecord` interface definition:

```
public interface IDataRecord
{
    int FieldCount { get; }
    object this[ int i ] { get; }
    object this[ string name ] { get; }
    string GetName(int i);
    string GetDataTypeName(int i);
    Type GetFieldType(int i);
    object GetValue(int i);
    int GetValues(object[] values);
}
```

```

int GetOrdinal(string name);
bool GetBoolean(int i);
byte GetByte(int i);
long GetBytes(int i, long fieldOffset, byte[] buffer, int bufferoffset, int length);
char GetChar(int i);
long GetChars(int i, long fieldoffset, char[] buffer, int bufferoffset, int length);
Guid GetGuid(int i);
short GetInt16(int i);
int GetInt32(int i);
long GetInt64(int i);
float GetFloat(int i);
double GetDouble(int i);
string GetString(int i);
Decimal GetDecimal(int i);
DateTime GetDateTime(int i);
IDataReader GetData(int i);
bool IsDBNull(int i);
}

```

■ **Note** You can use the `IDataReader.IsDBNull()` method to discover programmatically whether a specified field is set to null before obtaining a value from the data reader (to avoid triggering a runtime exception). Also recall that C# supports nullable data types (see Chapter 4), which are ideal for interacting with data columns that could be null in the database table.

Abstracting Data Providers Using Interfaces

At this point, you should have a better idea of the common functionality found among all .NET data providers. Recall that even though the exact names of the implementing types will differ among data providers, you can program against these types in a similar manner—that’s the beauty of interface-based polymorphism. For example, if you define a method that takes an `IDbConnection` parameter, you can pass in any ADO.NET connection object, like so:

```

public static void OpenConnection(IDbConnection cn)
{
    // Open the incoming connection for the caller.
    connection.Open();
}

```

■ **Note** Interfaces are not strictly required; you can achieve the same level of abstraction using abstract base classes (such as `DbConnection`) as parameters or return values.

The same holds true for member return values. For example, consider the following simple C# Console Application project (named MyConnectionFactory), which allows you to obtain a specific connection object based on the value of a custom enumeration. For diagnostic purposes, you simply print the underlying connection object using reflection services and then enter the following code:

```
using System;
using static System.Console;
// Need these to get definitions of common interfaces,
// and various connection objects for our test.
using System.Data;
using System.Data.SqlClient;
using System.Data.Odbc;
using System.Data.OleDb;

namespace MyConnectionFactory
{
    // A list of possible providers.
    enum DataProvider
    { SqlServer, OleDb, Odbc, None }

    class Program
    {

        static void Main(string[] args)
        {
            WriteLine("**** Very Simple Connection Factory ****\n");
            // Get a specific connection.
            IDbConnection myConnection = GetConnection(DataProvider.SqlServer);
            WriteLine($"Your connection is a {myConnection.GetType().Name}");
            // Open, use and close connection...
            ReadLine();
        }

        // This method returns a specific connection object
        // based on the value of a DataProvider enum.
        static IDbConnection GetConnection(DataProvider dataProvider)
        {
            IDbConnection connection = null;
            switch (dataProvider)
            {
                case DataProvider.SqlServer:
                    connection = new SqlConnection();
                    break;
                case DataProvider.OleDb:
                    connection = new OleDbConnection();
                    break;
                case DataProvider.Odbc:
                    connection = new OdbcConnection();
                    break;
            }
        }
    }
}
```

```

        return connection;
    }
}
}

```

■ **Note** Visual Studio 2015 introduces `using static`. By adding `using static System.Console;` to your other `using` statements, you can simply write `WriteLine("some text")` instead of `Console.WriteLine("some text")`. For all the console projects in this and subsequent chapters, I will be using the shorter version by adding `using static System.Console;` to the top of my files.

The benefit of working with the general interfaces of `System.Data` (or, for that matter, the abstract base classes of `System.Data.Common`) is that you have a much better chance of building a flexible code base that can evolve over time. For example, today you might be building an application that targets Microsoft SQL Server; however, it's possible your company could switch to a different database months down the road. If you build a solution that hard-codes the Microsoft SQL Server-specific types of `System.Data.SqlClient`, you would obviously need to edit, recompile, and redeploy the assembly should the back-end database management system change.

Increasing Flexibility Using Application Configuration Files

To increase the flexibility of your ADO.NET applications, you could incorporate a client-side `*.config` file that uses custom key-value pairs within the `<appSettings>` element. Recall from Chapter 14 that you can obtain the custom data stored within a `*.config` file programmatically by using types within the `System.Configuration` namespace. For example, assume you have specified a data provider value within a configuration file, as in this example:

```

<configuration>
  <appSettings>
    <!-- This key value maps to one of our enum values. -->
    <add key="provider" value="SqlServer"/>
  </appSettings>
  <startup>
    <supportedRuntime version="v4.0" sku=".NETFramework,Version=v4.6"/>
  </startup>
</configuration>

```

With this, you could update `Main()` to obtain the underlying data provider programmatically. Doing this essentially builds a *connection object factory* that allows you to change the provider but without requiring you to recompile your code base (you simply change the `*.config` file). Here are the relevant updates to `Main()`:

```

static void Main(string[] args)
{
    WriteLine("**** Very Simple Connection Factory ****\n");
    // Read the provider key.
    string dataProviderString = ConfigurationManager.AppSettings["provider"];
    // Transform string to enum.

```

```

DataProvider dataProvider = DataProvider.None;
if (Enum.IsDefined(typeof (DataProvider), dataProviderString))
{
    dataProvider = (DataProvider) Enum.Parse(typeof (DataProvider), dataProviderString);
}
else
{
    WriteLine("Sorry, no provider exists!");
    ReadLine();
    return;
}
// Get a specific connection.
IDbConnection myConnection = GetConnection(dataProvider);
WriteLine($"Your connection is a {myConnection?.GetType().Name ?? "unrecognized type"}");
// Open, use and close connection...
ReadLine();
}

```

■ **Note** To use the `ConfigurationManager` type, be sure to set a reference to the `System.Configuration.dll` assembly and import the `System.Configuration` namespace.

At this point, you have authored some ADO.NET code that allows you to specify the underlying connection dynamically. One obvious problem, however, is that this abstraction is used only within the `MyConnectionFactory.exe` application. If you were to rework this example within a .NET code library (e.g., `MyConnectionFactory.dll`), you would be able to build any number of clients that could obtain various connection objects using layers of abstraction.

However, obtaining a connection object is only one aspect of working with ADO.NET. To make a worthwhile data provider factory library, you would also have to account for command objects, data readers, data adapters, transaction objects, and other data-centric types. Building such a code library would not necessarily be difficult, but it would require a considerable amount of code and time.

Since the release of .NET 2.0, the kind folks in Redmond have built this exact functionality directly into the .NET base class libraries. You will examine this formal API in just a moment; however, first you need to create a custom database to use throughout this chapter (and for many chapters to come).

■ **Source Code** You can find the `MyConnectionFactory` project in the Chapter 21 subdirectory.

Creating the AutoLot Database

As you work through this chapter, you will execute queries against a simple SQL Server test database named `AutoLot`. In keeping with the automotive theme used throughout this book, this database will contain three interrelated tables (`Inventory`, `Orders`, and `Customers`) that contain various bits of data representing order information for a fictional automobile sales company.

The assumption in this book is that you have a copy of Microsoft SQL Server (7.0 or higher) or a copy of Microsoft SQL Server Express Edition. The examples in this book will be using SQL Server 2014 Express. If you do not have either of these, please go here to download a copy:

<http://www.microsoft.com/en-us/server-cloud/products/sql-server-editions/overview.aspx>

This lightweight database server is perfect for your needs in this book: it is free, it provides a GUI front end (the SQL Server Management Tool) to create and administer your databases, and it integrates with Visual Studio/Visual Community Edition. To illustrate the last point, the remainder of this section will walk you through the construction of the AutoLot database using Visual Studio.

■ **Note** You will use the AutoLot database throughout the rest of this book.

Creating the Inventory Table

To begin building your testing database, launch Visual Studio and open the Server Explorer using the View menu of the IDE. Next, right-click the Data Connections node and select the Create New SQL Server Database menu option (see Figure 21-3).

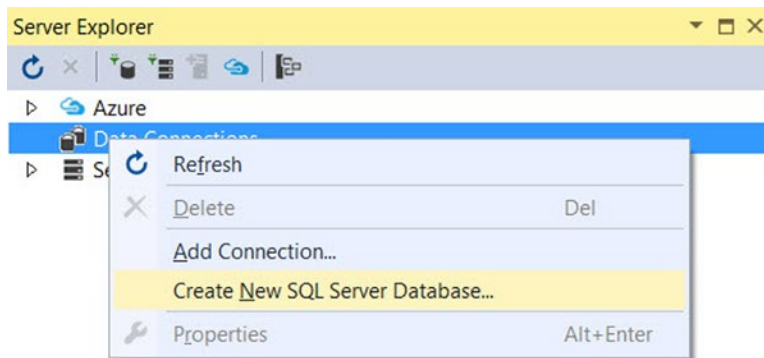

Figure 21-3. Creating a new SQL Server database within Visual Studio

In the resulting dialog box, you will need to enter a value into the “Server name” text area, which represents the machine where the database will be created. The server name consists of the machine identifier and the instance name. If you have installed Microsoft SQL Server (either the full version or Express) on your machine, enter (local)—including the parentheses—or a period followed by a backslash and the instance name (or blank if using the default instance). For example, on my machine, I need to enter .\SQLEXPRESS2014.

Name your new database AutoLot (Windows Authentication should be fine; see Figure 21-4).

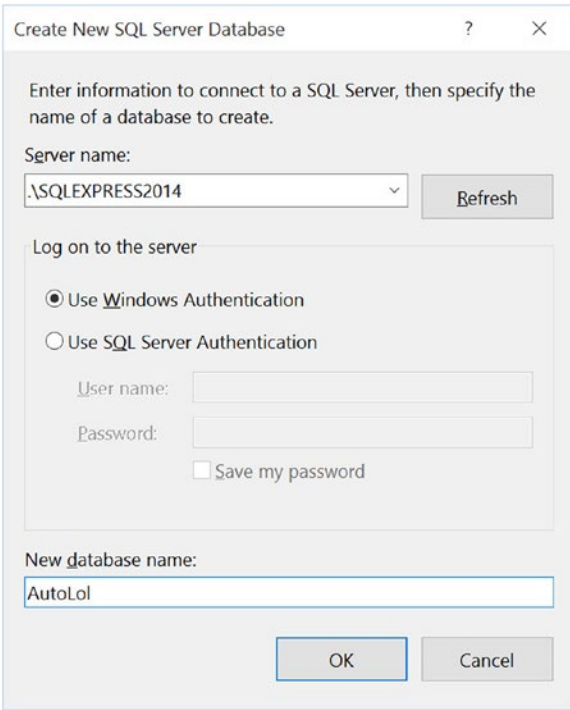

Figure 21-4. Creating a new SQL Server Express database with Visual Studio

At this point, the AutoLot database is empty of any database objects (e.g., tables, stored procedures, and so on). To insert a new database table, right-click the Tables node and select Add New Table (see Figure 21-5).

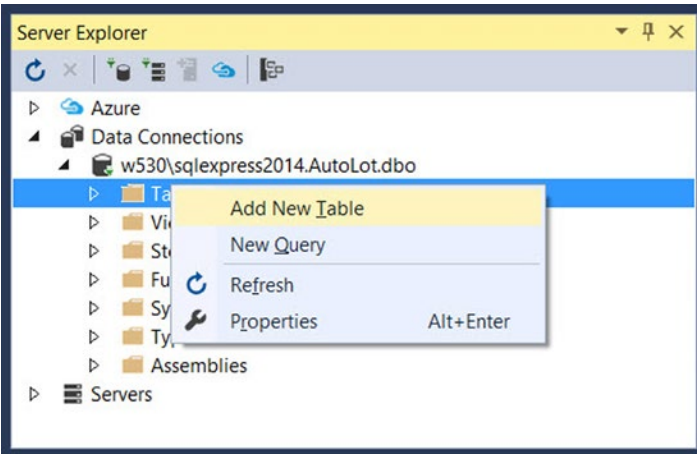

Figure 21-5. Adding the Inventory table

Use the table editor to add four columns (CarId, Make, Color, and PetName). Set CarId as type int and the other properties as type nvarchar(50). Ensure that the CarId column has been set to the primary key (do this by right-clicking the CarId row and selecting Set Primary Key) and as an identity specification (changed in the Properties tab by adding IDENTITY to the SQL or by adding the Identity column into the table designer, as shown in Figure 21-6). Also, notice that all columns but CarId can be assigned null values. Figure 21-6 shows the final table settings.

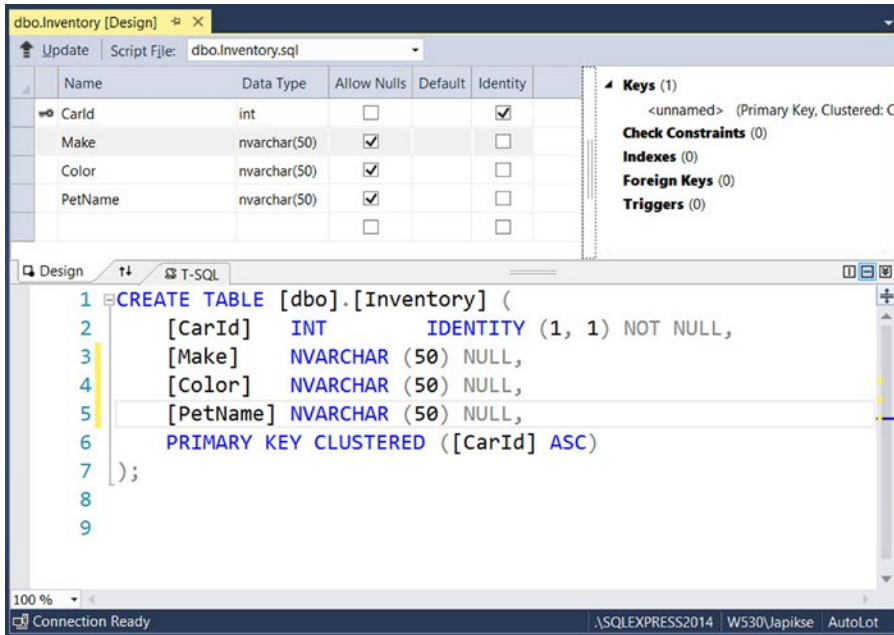

Figure 21-6. Designing the Inventory table

After you have created the table schema, name the table Inventory in the T-SQL window then save your work by clicking the Update button (as shown in Figure 21-6). On the next screen (Figure 21-7), click Update Database to commit the action.

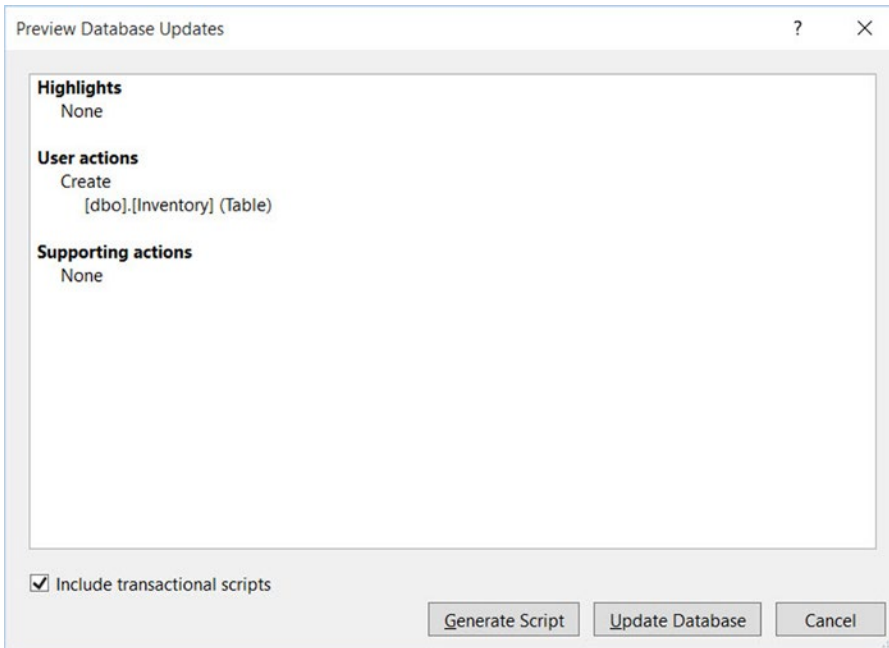

Figure 21-7. Committing the Inventory table to the database

Adding Test Records to the Inventory Table

To add records to your first table, right-click the Inventory table icon and select Show Table Data. Note: If you don't see the Inventory table, right-click the Tables folder and click Refresh. Enter a handful of new automobiles of your choosing (to make it interesting, be sure to include some cars that have identical colors and makes). Remember that the CarId field is an identity column, so the database takes care of creating a unique value for you. Figure 21-8 shows one possible list of inventory.

| | CarId | Make | Color | PetName |
|---|-------|------|--------|---------|
| ▶ | 1 | VW | Black | Zippy |
| | 2 | Ford | Rust | Rusty |
| | 3 | Saab | Black | Mel |
| | 4 | Yugo | Yellow | Clunker |
| | 5 | BMW | Black | Bimmer |
| | 6 | BMW | Green | Hank |
| | 7 | BMW | Pink | Pinky |
| * | NULL | NULL | NULL | NULL |

Figure 21-8. Populating the Inventory table

Authoring the GetPetName() Stored Procedure

Later in this chapter, you will learn how to use ADO.NET to invoke stored procedures. As you might already know, stored procedures are routines stored within a particular database that operate often on table data to yield a return value. You will add a single stored procedure that will return an automobile's pet name, based on the supplied CarId value. To do so, right-click the Stored Procedures node of the AutoLot database within the Server Explorer and select Add New Stored Procedure. Enter the following in the editor that pops up:

```
CREATE PROCEDURE GetPetName
@carID int,
@petName char(10) output
AS
SELECT @petName = PetName from Inventory where CarId = @carID
```

■ **Note** Stored procedures do not have to return data using output parameters, as shown here; however, doing things this way sets the stage for talking about the `Direction` property of the `SqlParameter`, which I will cover later in this chapter.

When you click Update to save your procedure, it will automatically be named `GetPetName`, based on your `CREATE PROCEDURE` statement. After you do this, you should see your new stored procedure within the Server Explorer (see Figure 21-9).

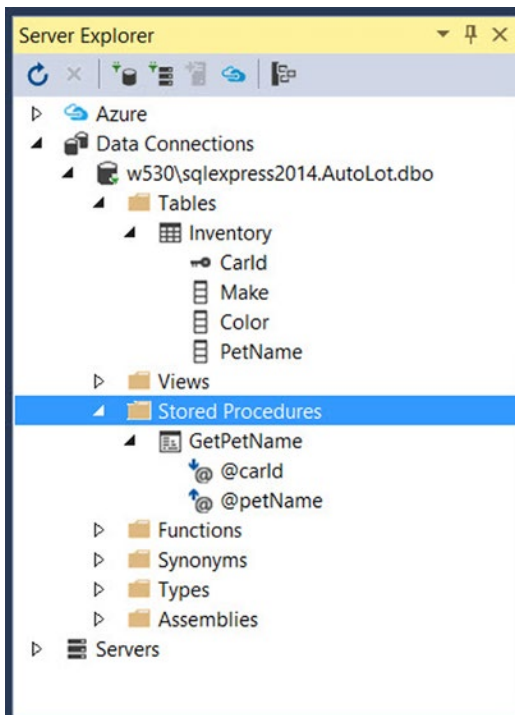

Figure 21-9. The `GetPetName` stored procedure

Creating the Customers and Orders Tables

The AutoLot database will have two additional tables: Customers and Orders. The Customers table (as the name suggests) will contain a list of customers and will be represented by three columns: CustId (which should be set as the primary key), FirstName, and LastName. You can create the Customers table by following the same steps you used to create the Inventory table; be sure to create the Customers table using the schema shown in Figure 21-10.

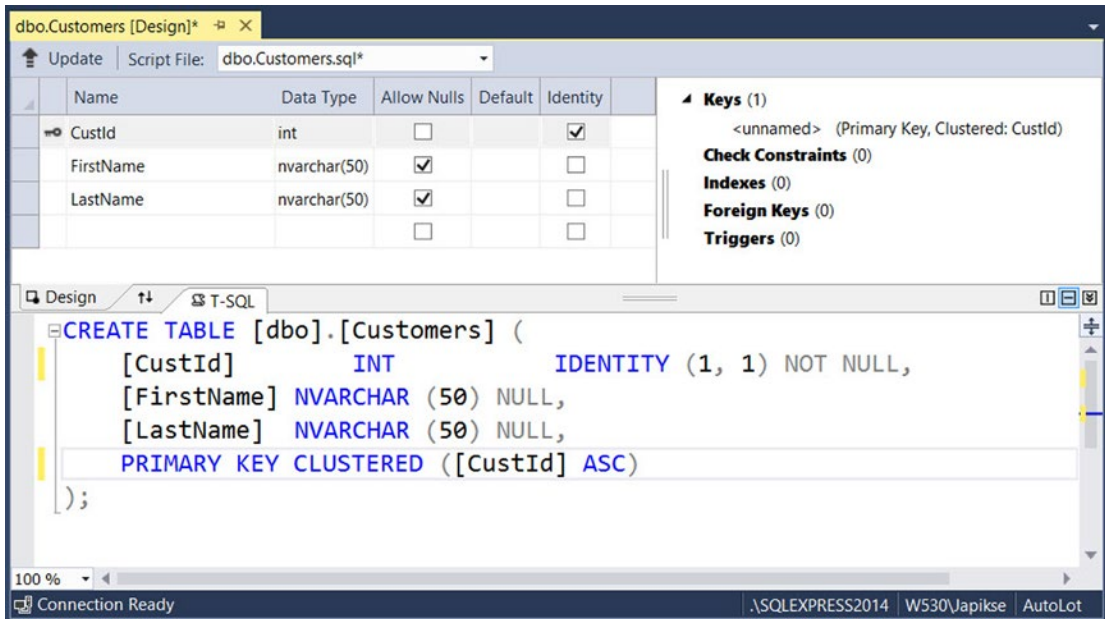

Figure 21-10. Designing the Customers table

After you save and name your table, add a handful of customer records (see Figure 21-11).

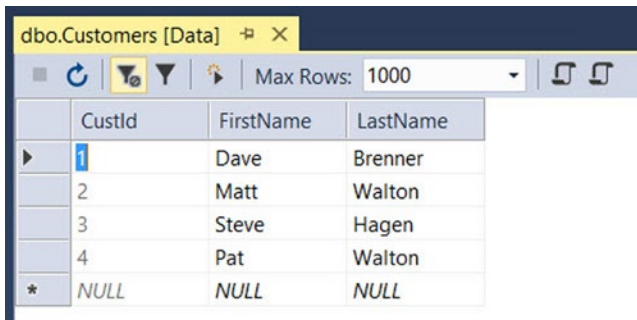

Figure 21-11. Populating the Customers table

You will use your final table, `Orders`, to represent the automobile a given customer is interested in purchasing. Do this by mapping `OrderId` values to `CarId/CustId` values. Figure 21-12 shows the structure of your final table (again, note that `OrderId` is the primary key).

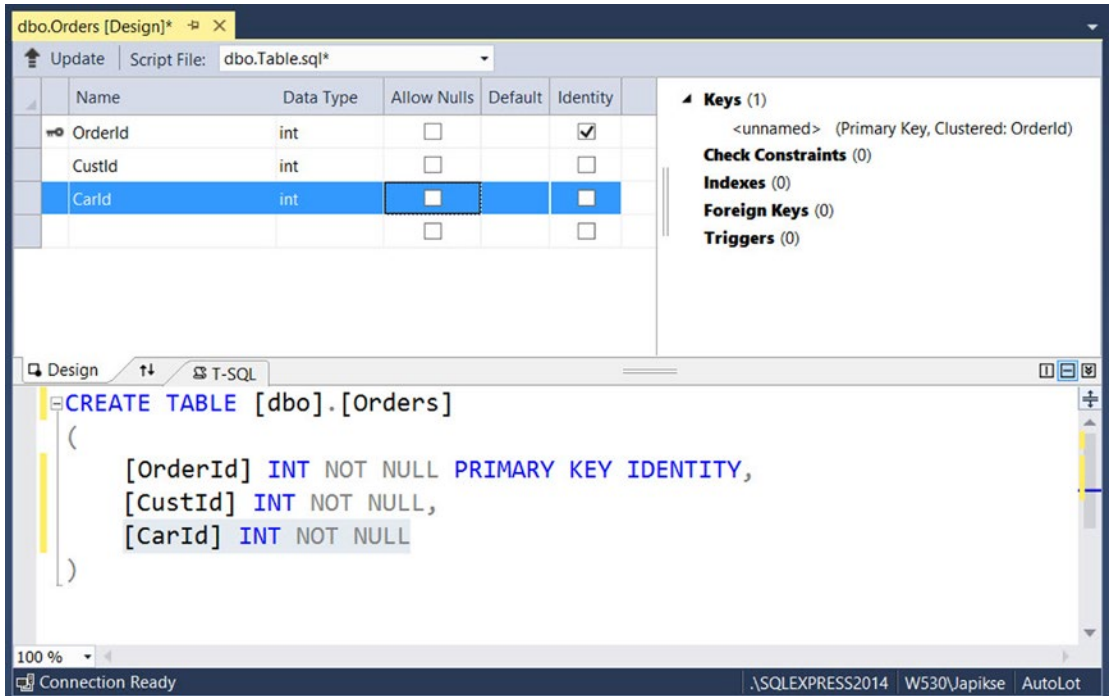

Figure 21-12. Designing the `Orders` table

Now add data to your `Orders` table. You haven't created any table relationships yet, so you will have to manually make sure that you enter values that exist in each table. Select a unique `CarId` for each `CustId` value (see Figure 21-13 for entries based on the previously shown sample data).

| OrderId | CustId | CarId |
|---------|--------|-------|
| 2 | 1 | 5 |
| 3 | 2 | 1 |
| 4 | 3 | 4 |
| 5 | 4 | 7 |
| * NULL | NULL | NULL |

Figure 21-13. Populating the `Orders` table

For example, the entries used in this text indicate that Dave Brenner (CustId = 1) is interested in the black BMW (CarId = 5), while Pat Walton (CustId = 4) has her eye on the pink BMW (CarId = 7).

Creating Table Relationships in Visual Studio

The final task is to establish parent-child table relationships between the Customers, Orders, and Inventory tables. Right-click the Orders table and select Open Table Definition. To the right of the columns grid, right-click Foreign Keys and select Add New Foreign Key, as in Figure 21-14.

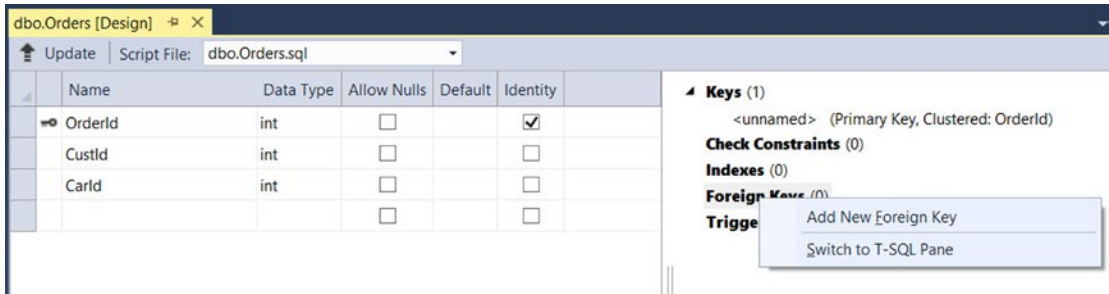

Figure 21-14. Creating a new foreign key

The default name for the foreign key is FK_<CurrentTable>_ToTable. In this case, it enters FK_Orders_ToTable. Replace ToTable with Inventory. At the time of this writing, there is an issue with the Properties grid for foreign keys, so you have to update the SQL manually. In the T-SQL Editor Window, update the following line:

```
CONSTRAINT [FK_Orders_Inventory] FOREIGN KEY ([Column]) REFERENCES [ToTable]
([ToTableColumn])
```

to the following:

```
CONSTRAINT [FK_Orders_Inventory] FOREIGN KEY ([CarId]) REFERENCES [Inventory]([CarId]),
```

Copy the Constraint to a new line in the T-SQL Editor window, and update it to match the following (make sure the inventory constraint is followed by a comma):

```
CONSTRAINT [FK_Orders_Customers] FOREIGN KEY ([CustId]) REFERENCES [dbo].[Customers]
([CustId]),
```

The complete SQL for the table looks like should look like this (there might be some minor differences based on the version of SQL Server that you are using):

```
CREATE TABLE [dbo].[Orders] (
    [OrderId] INT IDENTITY (1, 1) NOT NULL,
    [CustId] INT NOT NULL,
    [CarId] INT NOT NULL,
    PRIMARY KEY CLUSTERED ([OrderId] ASC),
```

```

CONSTRAINT [FK_Orders_Inventory] FOREIGN KEY ([CarId])
REFERENCES [Inventory]([CarId]),
CONSTRAINT [FK_Orders_Customers] FOREIGN KEY ([CustId])
REFERENCES [Customers]([CustId]),
);

```

Click Update in the designer and then Update in the following dialog, and the relationships are added to the AutoLot database. If you encounter an error while updating the database, it means that the data you entered into the orders table isn't correct. For example, you entered a CustId into Orders that doesn't exist in the Customers table. Correct the data and update the database again.

With this, the AutoLot database is complete! Of course, this is a far cry from a real-world corporate database, but it will serve your needs over the remainder of this book. Now that you have a database to test with, you can dive into the details of the ADO.NET data provider factory model.

The ADO.NET Data Provider Factory Model

The .NET data provider factory pattern allows you to build a single code base using generalized data access types. Furthermore, using application configuration files (and the <connectionStrings> subelement), you can obtain providers and connection strings declaratively, without the need to recompile or redeploy the assembly that uses the ADO.NET APIs.

To understand the data provider factory implementation, recall from Table 21-1 that the classes within a data provider each derive from the same base classes defined within the System.Data.Common namespace.

- DbCommand: The abstract base class for all command classes
- DbConnection: The abstract base class for all connection classes
- DbDataAdapter: The abstract base class for all data adapter classes
- DbDataReader: The abstract base class for all data reader classes
- DbParameter: The abstract base class for all parameter classes
- DbTransaction: The abstract base class for all transaction classes

Each of the Microsoft-supplied data providers contains a class type that derives from System.Data.Common.DbProviderFactory. This base class defines several methods that retrieve provider-specific data objects. Here are the members of DbProviderFactory:

```

public abstract class DbProviderFactory
{
    ..public virtual bool CanCreateDataSourceEnumerator { get;};
    public virtual DbCommand CreateCommand();
    public virtual DbCommandBuilder CreateCommandBuilder();
    public virtual DbConnection CreateConnection();
    public virtual DbConnectionStringBuilder CreateConnectionStringBuilder();
    public virtual DbDataAdapter CreateDataAdapter();
    public virtual DbParameter CreateParameter();
    public virtual CodeAccessPermission CreatePermission(PermissionState state);
    public virtual DbDataSourceEnumerator CreateDataSourceEnumerator();
}

```

To obtain the `DbProviderFactory`-derived type for your data provider, the `System.Data.Common` namespace provides a class type named `DbProviderFactories` (note the plural in this type's name). You can use the static `GetFactory()` method to obtain the specific `DbProviderFactory` object of the specified data provider; do this by specifying a string name that represents the .NET namespace containing the provider's functionality, like so:

```
static void Main(string[] args)
{
    // Get the factory for the SQL data provider.
    DbProviderFactory sqlFactory =
        DbProviderFactories.GetFactory("System.Data.SqlClient");
    ...
}
```

Of course, rather than obtaining a factory using a hard-coded string literal, you could instead read in this information from a client-side `*.config` file (much like the earlier `MyConnectionFactory` example). You will learn how to do this shortly; for the moment, you can obtain the associated provider-specific data objects (e.g., connections, commands, and data readers) once you have obtained the factory for your data provider.

■ **Note** For all practical purposes, you can regard the argument sent to `DbProviderFactories.GetFactory()` as the name of the data provider's .NET namespace. In reality, the `machine.config` value uses this string value to load the correct library dynamically from the Global Assembly Cache.

A Complete Data Provider Factory Example

For a complete example, you can create a new C# Console Application (named `DataProviderFactory`) that prints out the automobile inventory of the `AutoLot` database. For this initial example, you will hard-code the data access logic directly within the `DataProviderFactory.exe` assembly (to keep things simple for the time being). However, when you begin to dig into the details of the ADO.NET programming model, you will isolate your data logic to a specific .NET code library that you will use for the remainder of this book.

Begin by adding a reference to the `System.Configuration.dll` assembly and importing the `System.Configuration` namespace. Next, update the `App.config` file to include an empty `<appSettings>` element. Add a new key-named provider that maps to the namespace name of the data provider you want to obtain (`System.Data.SqlClient`). Also, define a connection string that represents a connection to the `AutoLot` database (on the local instance of SQL Server Express).

```
<?xml version="1.0" encoding="utf-8" ?>
<configuration>
  <appSettings>
    <!-- Which provider? -->
    <add key="provider" value="System.Data.SqlClient" />

    <!-- Which connection string? -->
    <add key="connectionString" value="Data Source=(local)\SQLEXPRESS2014;
      Initial Catalog=AutoLot;Integrated Security=True"/>
  </appSettings>
```



```
<startup>
  <supportedRuntime version="v4.0" sku=".NETFramework,Version=v4.6"/>
</startup>
</configuration>
```

■ **Note** You will learn about connection strings in more detail momentarily; however, if you select your AutoLot database icon within the Server Explorer, you can copy and paste the correct connection string from the Connection String property of the Visual Studio Properties window.

Now that you have a proper *.config file, you can read in the provider and connectionString values using the ConfigurationManager.AppSettings indexer. The provider value will be passed to DbProviderFactories.GetFactory() to obtain the data provider-specific factory type. You will use the connectionString value to set the ConnectionString property of the DbConnection-derived type.

Assuming you have imported the System.Data, System.Data.Common, and static System.Console namespaces, you can update your Main() method like this:

```
static void Main(string[] args)
{
    WriteLine("***** Fun with Data Provider Factories *****\n");
    // Get Connection string/provider from *.config.
    string dataProvider =
        ConfigurationManager.AppSettings["provider"];
    string connectionString =
        ConfigurationManager.AppSettings["connectionString"];

    // Get the factory provider.
    DbProviderFactory factory = DbProviderFactories.GetFactory(dataProvider);

    // Now get the connection object.
    using (DbConnection connection = factory.CreateConnection())
    {
        if (connection == null)
        {
            ShowError("Connection");
            return;
        }
        WriteLine($"Your connection object is a: {connection.GetType().Name}");
        connection.ConnectionString = connectionString;
        connection.Open();

        // Make command object.
        DbCommand command = factory.CreateCommand();
        if (command == null)
        {
            ShowError("Command");
            return;
        }
    }
}
```

```

WriteLine($"Your command object is a: {command.GetType().Name}");
command.Connection = connection;
command.CommandText = "Select * From Inventory";

// Print out data with data reader.
using (DbDataReader dataReader = command.ExecuteReader())
{
    WriteLine($"Your data reader object is a: {dataReader.GetType().Name}");

    WriteLine("\n***** Current Inventory *****");
    while (dataReader.Read())
        WriteLine($"-> Car #{dataReader["CarId"]} is a {dataReader["Make"]}.");
}
}
ReadLine();
}

private static void ShowError(string objectName)
{
    WriteLine($"There was an issue creating the {objectName}");
    ReadLine();
}
}

```

Notice that, for diagnostic purposes, you use reflection services to print the name of the underlying connection, command, and data reader. If you run this application, you will find the following current data in the Inventory table of the AutoLot database printed to the console:

```

***** Fun with Data Provider Factories *****

Your connection object is a: SqlConnection
Your command object is a: SqlCommand
Your data reader object is a: SqlDataReader

***** Current Inventory *****
-> Car #1 is a VW.
-> Car #2 is a Ford.
-> Car #3 is a Saab.
-> Car #4 is a Yugo.
-> Car #5 is a BMW.
-> Car #6 is a BMW.
-> Car #7 is a BMW.

```

Now change the *.config file to specify System.Data.OleDb as the data provider (and update your connection string with a Provider segment and change the Integrated Security value from true to SSPI), like so:

```

<configuration>
  <appSettings>
    <!-- Which provider? -->
    <add key="provider" value="System.Data.OleDb" />
    <!-- Which connection string? -->
    <add key="cnStr" value=

```

```

    "Provider=SQLOLEDB;Data Source=(local)\SQLEXPRESS2014;
      Integrated Security=SSPI;Initial Catalog=AutoLot"/>
</appSettings>
<startup>
  <supportedRuntime version="v4.0" sku=".NETFramework,Version=v4.6"/>
</startup>
</configuration>

```

Doing this indicates that the `System.Data.OleDb` types are used behind the scenes and gives the following output:

```
***** Fun with Data Provider Factories *****
```

```

Your connection object is a: OleDbConnection
Your command object is a: OleDbCommand
Your data reader object is a: OleDbDataReader

```

```
***** Current Inventory *****
```

```

-> Car #1 is a VW.
-> Car #2 is a Ford.
-> Car #3 is a Saab.
-> Car #4 is a Yugo.
-> Car #5 is a BMW.
-> Car #6 is a BMW.
-> Car #7 is a BMW.

```

Of course, based on your experience with ADO.NET, you might be a bit unsure exactly what the connection, command, and data reader objects actually *do*. Don't sweat the details for the time being (quite a few pages remain in this chapter, after all!). At this point, it's enough to know that you can use the ADO.NET data provider factory model to build a single code base that can consume various data providers in a declarative manner.

A Potential Drawback with the Data Provider Factory Model

Although this is a powerful model, you must make sure that the code base uses only types and methods common to all providers through the members of the abstract base classes. Therefore, when authoring your code base, you are limited to the members exposed by `DbConnection`, `DbCommand`, and the other types of the `System.Data.Common` namespace.

Given this, you might find that this generalized approach prevents you from directly accessing some of the bells and whistles of a particular DBMS. If you must be able to invoke specific members of the underlying provider (e.g., `SqlConnection`), you can do so using an explicit cast, as in this example:

```

using (DbConnection connection = factory.CreateConnection())
{
    if (connection == null)
    {
        ShowError("Connection");
        return;
    }
}

```

```

WriteLine($"Your connection object is a: {connection.GetType().Name}");
connection.ConnectionString = connectionString;
connection.Open();

var sqlConnection = connection as SqlConnection;
if (sqlConnection != null)
{
    // Print out which version of SQL Server is used.
    WriteLine(sqlConnection.ServerVersion);
}
//Remainder removed for brevity
}

```

When doing this, however, your code base becomes a bit harder to maintain (and less flexible) because you must add a number of runtime checks. Nevertheless, if you need to build data access libraries in the most flexible way possible, the data provider factory model provides a great mechanism for doing so.

The <connectionStrings> Element

Currently, your connection string data is in the <appSettings> element of your *.config file. Application configuration files can define an element named <connectionStrings>. Within this element, you can define any number of name-value pairs that can be programmatically read into memory using the `ConfigurationManager.ConnectionStrings` indexer. One advantage of this approach (as opposed to using the <appSettings> element and the `ConfigurationManager.AppSettings` indexer) is that you can define multiple connection strings for a single application in a consistent manner.

To see this in action, update your current `App.config` file as follows (note that each connection string is documented using the name and `connectionString` attributes rather than the key and value attributes you find in <appSettings>):

```

<configuration>
  <appSettings>
    <!-- Which provider? -->
    <add key="provider" value="System.Data.SqlClient" />
  </appSettings>

  <!-- Here are the connection strings. -->
  <connectionStrings>
    <add name="AutoLotSqlProvider" connectionString =
      "Data Source=(local)\SQLEXPRESS2014;
      Integrated Security=SSPI;Initial Catalog=AutoLot"/>

    <add name="AutoLotOleDbProvider" connectionString =
      "Provider=SQLOLEDB;Data Source=(local)\SQLEXPRESS2014;
      Integrated Security=SSPI;Initial Catalog=AutoLot"/>
  </connectionStrings>
  <startup>
    <supportedRuntime version="v4.0" sku=".NETFramework,Version=v4.6"/>
  </startup>
</configuration>

```

You can now update your `Main()` method as follows:

```
static void Main(string[] args)
{
    WriteLine("***** Fun with Data Provider Factories *****\n");
    string dataProvider =
        ConfigurationManager.AppSettings["provider"];
    string connectionString =
        ConfigurationManager.ConnectionStrings["AutoLotSqlProvider"].ConnectionString;
    ...
}
```

At this point, you have an application that can display the results of the `Inventory` table of the `AutoLot` database using a neutral code base. Offloading the provider name and connection string to an external `*.config` file means that the data provider factory model can dynamically load the correct provider in the background. With this first example behind you, you can now dive into the details of working with the connected layer of ADO.NET.

■ **Note** Now that you understand the role of ADO.NET data provider factories, the remaining examples in this book will focus on the task at hand by explicitly using the types within the `System.Data.SqlClient` namespace. If you use a different database management system (such as Oracle), you would need to update your code base accordingly.

■ **Source Code** You can find the `DataProviderFactory` project in the [Chapter 21](#) subdirectory.

Understanding the Connected Layer of ADO.NET

Recall that the *connected layer* of ADO.NET allows you to interact with a database using the connection, command, and data reader objects of your data provider. You have already used these objects in the previous `DataProviderFactory` application, and now you'll walk through the process again, this time using an expanded example. You need to perform the following steps when you want to connect to a database and read the records using a data reader object:

1. Allocate, configure, and open your connection object.
2. Allocate and configure a command object, specifying the connection object as a constructor argument or with the `Connection` property.
3. Call `ExecuteReader()` on the configured command class.
4. Process each record using the `Read()` method of the data reader.

To get the ball rolling, create a new Console Application project named `AutoLotDataReader` and import the `System.Data` and `System.Data.SqlClient` namespaces. Here is the complete code within `Main()` (analysis will follow):

```
class Program
{
    static void Main(string[] args)
    {
        WriteLine("***** Fun with Data Readers *****\n");

        // Create and open a connection.
        using (SqlConnection connection = new SqlConnection())
        {
            connection.ConnectionString =
                @"Data Source=(local)\SQLEXPRESS2014;Integrated Security=SSPI;" +
                "Initial Catalog=AutoLot";
            connection.Open();

            // Create a SQL command object.
            string sql = "Select * From Inventory";
            SqlCommand myCommand = new SqlCommand(sql, connection);

            // Obtain a data reader a la ExecuteReader().
            using (SqlDataReader myDataReader = myCommand.ExecuteReader())
            {
                // Loop over the results.
                while (myDataReader.Read())
                {
                    WriteLine($"-> Make: {myDataReader["Make"]}, PetName: {myDataReader["PetName"]},
                        Color: {myDataReader["Color"]}");
                }
            }
        }
        ReadLine();
    }
}
```

Working with Connection Objects

The first step to take when working with a data provider is to establish a session with the data source using the connection object (which, as you recall, derives from `DbConnection`). .NET connection objects are provided with a formatted *connection string*; this string contains a number of name-value pairs, separated by semicolons. You use this information to identify the name of the machine you want to connect to, required security settings, the name of the database on that machine, and other data provider-specific information.

As you can infer from the preceding code, the `Initial Catalog` name refers to the database you want to establish a session with. The `Data Source` name identifies the name of the machine that maintains the database. Here, `(local)` allows you to define a single token to specify the current local machine (regardless of the literal name of said machine), while the `\SQLEXPRESS2014` token informs the SQL Server provider that you are connecting to a SQL Server Express edition with the named instance of `SQLEXPRESS2014`. If you created `AutoLot` on a Microsoft SQL Server set up as the default instance on your local computer, specify `Data Source=(local)`.

■ **Note** There is another mechanism that uses (LocalDb) for the server name. This stores the database with the project/solution. You can still access the database through Server Explorer by using (LocalDb)\MSSQLLocalDB as the server name (or (LocalDb)\v11.0, depending on your version of the starter templates with Visual Studio).

Beyond this, you can supply any number of tokens that represent security credentials. Here, you set the Integrated Security to SSPI (equivalent to true for SQL Server connection strings), which uses the current Windows account credentials for user authentication.

■ **Note** Look up the ConnectionString property of your data provider's connection object in the .NET Framework 4.6 SDK documentation to learn more about each name-value pair for your specific DBMS.

After you establish your connection string, you can use a call to `Open()` to establish a connection with the DBMS. In addition to the `ConnectionString`, `Open()`, and `Close()` members, a connection object provides a number of members that let you configure additional settings regarding your connection, such as timeout settings and transactional information. Table 21-5 lists some (but not all) members of the `DbConnection` base class.

Table 21-5. *Members of the DbConnection Type*

| Member | Meaning in Life |
|---------------------------------|--|
| <code>BeginTransaction()</code> | You use this method to begin a database transaction. |
| <code>ChangeDatabase()</code> | You use this method to change the database on an open connection. |
| <code>ConnectionTimeout</code> | This read-only property returns the amount of time to wait while establishing a connection before terminating and generating an error (the default value is 15 seconds). If you would like to change the default, specify a <code>Connect Timeout=30</code> segment in the connection string (e.g., <code>Connect Timeout=30</code>). |
| <code>Database</code> | This read-only property gets the name of the database maintained by the connection object. |
| <code>DataSource</code> | This read-only property gets the location of the database maintained by the connection object. |
| <code>GetSchema()</code> | This method returns a <code>DataTable</code> object that contains schema information from the data source. |
| <code>State</code> | This read-only property gets the current state of the connection, which is represented by the <code>ConnectionState</code> enumeration. |

The properties of the `DbConnection` type are typically read-only in nature and are useful only when you want to obtain the characteristics of a connection at runtime. When you need to override default settings, you must alter the construction string itself. For example, the following connection string sets the connection timeout setting from 15 seconds to 30 seconds:

```
static void Main(string[] args)
{
    WriteLine("***** Fun with Data Readers *****\n");

    using(SqlConnection connection = new SqlConnection())
    {
        connection.ConnectionString =
            @"Data Source=(local)\SQLEXPRESS2014;" +
            "Integrated Security=SSPI;Initial Catalog=AutoLot;Connect Timeout=30";
        connection.Open();

        // New helper function (see below).
        ShowConnectionStatus(connection);
    }
    ...
}
```

In the preceding code, you pass your connection object as a parameter to a new static helper method in the `Program` class named `ShowConnectionStatus()`, which you implement as follows:

```
static void ShowConnectionStatus(SqlConnection connection)
{
    // Show various stats about current connection object.
    WriteLine("***** Info about your connection *****");
    WriteLine($"Database location: {connection.DataSource}");
    WriteLine($"Database name: {connection.Database}");
    WriteLine($"Timeout: {connection.ConnectionTimeout}");
    WriteLine($"Connection state: {connection.State}\n");
}
```

While most of these properties are self-explanatory, the `State` property is worth special mention. You can assign this property any value of the `ConnectionState` enumeration, as shown here:

```
public enum ConnectionState
{
    Broken, Closed,
    Connecting, Executing,
    Fetching, Open
}
```

However, the only valid `ConnectionState` values are `ConnectionState.Open`, `ConnectionState.Connecting`, and `ConnectionState.Closed` (the remaining members of this enum are reserved for future use). Also, it is always safe to close a connection where connection state is currently `ConnectionState.Closed`.

Working with SqlConnectionStringBuilder Objects

Working with connection strings programmatically can be cumbersome because they are often represented as string literals, which are difficult to maintain and error-prone at best. The Microsoft-supplied ADO.NET data providers support *connection string builder objects*, which allow you to establish the name-value pairs using strongly typed properties. Consider the following update to the current `Main()` method:

```
static void Main(string[] args)
{
    WriteLine("***** Fun with Data Readers *****\n");

    // Create a connection string via the builder object.
    var cnStringBuilder = new SqlConnectionStringBuilder
    {
        InitialCatalog = "AutoLot",
        DataSource = @"(local)\SQLEXPRESS2014",
        ConnectTimeout = 30,
        IntegratedSecurity = true
    };

    using(SqlConnection connection = new SqlConnection())
    {
        connection.ConnectionString = cnStringBuilder.ConnectionString;
        connection.Open();
        ShowConnectionStatus(connection);
    }
    ...
}
ReadLine();
}
```

In this iteration, you create an instance of `SqlConnectionStringBuilder`, set the properties accordingly, and obtain the internal string using the `ConnectionString` property. Also note that you use the default constructor of the type. If you so choose, you can also create an instance of your data provider's connection string builder object by passing in an existing connection string as a starting point (this can be helpful when you read these values dynamically from an `App.config` file). Once you have hydrated the object with the initial string data, you can change specific name-value pairs using the related properties, as in this example:

```
static void Main(string[] args)
{
    WriteLine("***** Fun with Data Readers *****\n");

    // Assume you really obtained the connectionString value from a *.config file.
    string connectionString = @"Data Source=(local)\SQLEXPRESS;" +
        "Integrated Security=SSPI;Initial Catalog=AutoLot";

    SqlConnectionStringBuilder cnStringBuilder =
        new SqlConnectionStringBuilder(connectionString);

    // Change timeout value.
    cnStringBuilder.ConnectTimeout = 5;
    ...
}
```

Working with Command Objects

Now that you understand better the role of the connection object, the next order of business is to check out how to submit SQL queries to the database in question. The `SqlCommand` type (which derives from `DbCommand`) is an OO representation of a SQL query, table name, or stored procedure. You specify the type of command using the `CommandType` property, which can take any value from the `CommandType` enum, as shown here:

```
public enum CommandType
{
    StoredProcedure,
    TableDirect,
    Text // Default value.
}
```

When you create a command object, you can establish the SQL query as a constructor parameter or directly by using the `CommandText` property. Also when you create a command object, you need to specify the connection you want to use. Again, you can do so as a constructor parameter or by using the `Connection` property. Consider this code snippet:

```
// Create command object via ctor args.
string sql = "Select * From Inventory";
SqlCommand myCommand = new SqlCommand(sql, connection);
// Create another command object via properties.
SqlCommand testCommand = new SqlCommand();
testCommand.Connection = connection;
testCommand.CommandText = sql;
```

Realize that, at this point, you have not literally submitted the SQL query to the AutoLot database but instead prepared the state of the command object for future use. Table 21-6 highlights some additional members of the `DbCommand` type.

Table 21-6. *Members of the DbCommand Type*

| Member | Meaning in Life |
|--------------------------------|---|
| <code>CommandTimeout</code> | Gets or sets the time to wait while executing the command before terminating the attempt and generating an error. The default is 30 seconds. |
| <code>Connection</code> | Gets or sets the <code>DbConnection</code> used by this instance of the <code>DbCommand</code> . |
| <code>Parameters</code> | Gets the collection of <code>DbParameter</code> objects used for a parameterized query. |
| <code>Cancel()</code> | Cancels the execution of a command. |
| <code>ExecuteReader()</code> | Executes a SQL query and returns the data provider's <code>DbDataReader</code> object, which provides forward-only, read-only access for the result of the query. |
| <code>ExecuteNonQuery()</code> | Executes a SQL nonquery (e.g., an insert, update, delete, or create table). |
| <code>ExecuteScalar()</code> | A lightweight version of the <code>ExecuteReader()</code> method that was designed specifically for singleton queries (e.g., obtaining a record count). |
| <code>Prepare()</code> | Creates a prepared (or compiled) version of the command on the data source. As you might know, a <i>prepared query</i> executes slightly faster and is useful when you need to execute the same query multiple times (typically with different parameters each time). |

Working with Data Readers

After you establish the active connection and SQL command, the next step is to submit the query to the data source. As you might guess, you have a number of ways to do this. The `DbDataReader` type (which implements `IDataReader`) is the simplest and fastest way to obtain information from a data store. Recall that data readers represent a read-only, forward-only stream of data returned one record at a time. Given this, data readers are useful only when submitting SQL selection statements to the underlying data store.

Data readers are useful when you need to iterate over large amounts of data quickly and you do not need to maintain an in-memory representation. For example, if you request 20,000 records from a table to store in a text file, it would be rather memory-intensive to hold this information in a `DataSet` (because a `DataSet` holds the entire result of the query in memory at the same time).

A better approach is to create a data reader that spins over each record as rapidly as possible. Be aware, however, that data reader objects (unlike data adapter objects, which you'll examine later) maintain an open connection to their data source until you explicitly close the connection.

You obtain data reader objects from the command object using a call to `ExecuteReader()`. The data reader represents the current record it has read from the database. The data reader has an indexer method (e.g., `[]` syntax in C#) that allows you to access a column in the current record. You can access the column either by name or by zero-based integer.

The following use of the data reader leverages the `Read()` method to determine when you have reached the end of your records (using a `false` return value). For each incoming record that you read from the database, you use the type indexer to print out the make, pet name, and color of each automobile. Also note that you call `Close()` as soon as you finish processing the records, which frees up the connection object.

```
static void Main(string[] args)
{
    ...
    // Obtain a data reader via ExecuteReader().
    using(SqlDataReader myDataReader = myCommand.ExecuteReader())
    {
        // Loop over the results.
        while (myDataReader.Read())
        {
            WriteLine($"-> Make: { myDataReader["Make"]}, PetName: { myDataReader["PetName"]},
            Color: { myDataReader["Color"]}.");
        }
        ReadLine();
    }
}
```

In the preceding snippet, you overload the indexer of a data reader object to take either a `string` (representing the name of the column) or an `int` (representing the column's ordinal position). Thus, you can clean up the current reader logic (and avoid hard-coded string names) with the following update (note the use of the `FieldCount` property):

```
while (myDataReader.Read())
{
    WriteLine("***** Record *****");
    for (int i = 0; i < myDataReader.FieldCount; i++)
```

```

{
    WriteLine($"{myDataReader.GetName(i)} = { myDataReader.GetValue(i)} ");
}
WriteLine();
}

```

If you compile and run your project at this point, you should see a list of all automobiles in the Inventory table of the AutoLot database. The following output shows the initial few records from my own version of AutoLot:

```

***** Fun with Data Readers *****

***** Info about your connection *****
Database location: (local)\SQLEXPRESS2014
Database name: AutoLot
Timeout: 30
Connection state: Open

***** Record *****
CarId = 1
Make = VW
Color = Black
PetName = Zippy

***** Record *****
CarId = 2
Make = Ford
Color = Rust
PetName = Rusty

```

Obtaining Multiple Result Sets Using a Data Reader

Data reader objects can obtain multiple result sets using a single command object. For example, if you want to obtain all rows from the Inventory table, as well as all rows from the Customers table, you can specify both SQL Select statements using a semicolon delimiter, like so:

```
string sql = "Select * From Inventory;Select * from Customers";
```

After you obtain the data reader, you can iterate over each result set using the `NextResult()` method. Note that you are always returned the first result set automatically. Thus, if you want to read over the rows of each table, you can build the following iteration construct:

```

do
{
    while (myDataReader.Read())
    {
        WriteLine("***** Record *****");
        for (int i = 0; i < myDataReader.FieldCount; i++)

```

```

    {
        WriteLine($"{myDataReader.GetName(i)} = {myDataReader.GetValue(i)}");
    }
    WriteLine();
}
} while (myDataReader.NextResult());

```

At this point, you should be more aware of the functionality data reader objects bring to the table. Always remember that a data reader can process only SQL `Select` statements; you cannot use them to modify an existing database table using `Insert`, `Update`, or `Delete` requests. Modifying an existing database requires additional investigation of command objects.

■ **Source Code** You can find the `AutoLotDataReader` project in the Chapter 21 subdirectory.

Building a Reusable Data Access Library

The `ExecuteReader()` method extracts a data reader object that allows you to examine the results of a SQL `Select` statement using a forward-only, read-only flow of information. However, when you want to submit SQL statements that result in the modification of a given table (or any other nonquery SQL statement, such as creating tables or granting permissions), you call the `ExecuteNonQuery()` method of your command object. This single method performs inserts, updates, and deletes based on the format of your command text.

■ **Note** Technically speaking, a *nonquery* is a SQL statement that does not return a result set. Thus, `Select` statements are queries, while `Insert`, `Update`, and `Delete` statements are not. Given this, `ExecuteNonQuery()` returns an `int` that represents the number of rows affected, not a new set of records.

Next, you will learn how to modify an existing database using nothing more than a call to `ExecuteNonQuery()`; your next goal is to build a custom data access library that can encapsulate the process of operating upon the `AutoLot` database. In a production-level environment, your ADO.NET logic will almost always be isolated to a `.NET *.dll` assembly for one simple reason: code reuse! The first examples of this chapter have not done this, simply so you can keep focused on the task at hand; however, it would be a waste of time to author the *same* connection logic, the *same* data reading logic, and the *same* command logic for every application that needs to interact with the `AutoLot` database.

Isolating data access logic to a `.NET` code library means that multiple applications using any sort of front end (e.g., console based, desktop based, or web based) can reference the library at hand in a language-independent manner. Thus, if you author your data library using `C#`, other developers can build a UI in the `.NET` language of their choice.

In this chapter, your data library (`AutoLotDAL.dll`) will contain a single namespace (`AutoLotConnectedLayer`) that interacts with `AutoLot` using the connected types of ADO.NET. In the next chapter, you will add a new namespace (`AutoLotDisconnectionLayer`) to this same `*.dll` that contains types to communicate with `AutoLot` using the disconnected layer. In Chapter 23, you will create a complete data access layer using Entity Framework. Multiple applications will take advantage of this library throughout the remainder of this book.

Begin by creating a new C# Class Library project named *AutoLotDAL* (short for *AutoLot Data Access Layer*) and delete the default class file. Add a new folder using the Project ► New Folder menu option (make sure you have the Project selected in Solution Explorer), and name this folder *ConnectedLayer*. In this new folder, add a new class named *InventoryDAL.cs*, and change the class to *public*. This class will define various members to interact with the *Inventory* table of the *AutoLot* database. Finally, import the following .NET namespaces:

```
using System;

// You will use the SQL server
// provider; however, it would also be
// permissible to use the ADO.NET
// factory pattern for greater flexibility.
using System.Data;
using System.Data.SqlClient;
using System.Collections.Generic;

namespace AutoLotDAL.ConnectedLayer
{
    public class InventoryDAL
    {
    }
}
```

■ **Note** You might recall from Chapter 13 that when objects use types that manage raw resources (e.g., a database connection), it is a good practice to implement *IDisposable* and author a proper finalizer. In a production environment, classes such as *InventoryDAL* would do the same; however, you won't do that here, so you can stay focused on the particulars of ADO.NET.

Adding the Connection Logic

The first task you must attend to is to define some methods that allow the caller to connect to and disconnect from the data source using a valid connection string. You will hard-code your *AutoLotDAL.dll* assembly to use the types of *System.Data.SqlClient*, so you need to define a private member variable of *SqlConnection* that is allocated at the time the *InventoryDAL* object is created. Also, define a method named *OpenConnection()* and another named *CloseConnection()* to interact with this member variable.

```
public class InventoryDAL
{
    // This member will be used by all methods.
    private SqlConnection _sqlConnection = null;

    public void OpenConnection(string connectionString)
    {
        _sqlConnection = new SqlConnection {ConnectionString = connectionString};
        _sqlConnection.Open();
    }
}
```

```

public void CloseConnection()
{
    _sqlConnection.Close();
}
}

```

For the sake of brevity, your `InventoryDAL` type will not test for possible exceptions, nor will it throw custom exceptions under various circumstances (e.g., a malformed connection string). If you were to build an industrial-strength data access library, you would absolutely want to use structured exception handling techniques to account for any runtime anomalies.

Adding the Insertion Logic

Inserting a new record into the `Inventory` table is as simple as formatting the SQL `Insert` statement (based on user input) and calling the `ExecuteNonQuery()` using your command object. You can see this in action by adding a public method to your `InventoryDAL` type named `InsertAuto()` that takes four parameters that map to the four columns of the `Inventory` table (`CarId`, `Color`, `Make`, and `PetName`). You use these arguments to format a string type to insert the new record. Finally, use your `SqlConnection` object to execute the SQL statement.

```

public void InsertAuto(int id, string color, string make, string petName)
{
    // Format and execute SQL statement.
    string sql = "Insert Into Inventory" +
        $"(Make, Color, PetName) Values ('{make}', '{color}', '{petName}')";

    // Execute using our connection.
    using (SqlCommand command = new SqlCommand(sql, _sqlConnection))
    {
        command.ExecuteNonQuery();
    }
}

```

This method is syntactically fine, but you could supply an overloaded version that allows the caller to pass in a strongly typed class that represents the data for the new row. Add a new folder to your project named `Models`, and add a new public class named `NewCar`. Define the following new `NewCar` class, which represents a new row in the `Inventory` table:

```

public class NewCar
{
    public int CarId { get; set; }
    public string Color { get; set; }
    public string Make { get; set; }
    public string PetName { get; set; }
}

```

Now add the following version of `InsertAuto()` to your `InventoryDAL` class (add a `using` for `AutoLotDAL.Models` to the top of the class):

```
public void InsertAuto(NewCar car)
{
    // Format and execute SQL statement.
    string sql = "Insert Into Inventory" +
        "( Make, Color, PetName) Values" +
        $"('{car.Make}', '{car.Color}', '{car.PetName}')";

    // Execute using our connection.
    using (SqlCommand command = new SqlCommand(sql, _sqlConnection))
    {
        command.ExecuteNonQuery();
    }
}
```

Defining classes that represent records in a relational database is a common way to build a data access library. In fact, as you will see in Chapter 23, the ADO.NET Entity Framework can automatically generate strongly typed classes that allow you to interact with database data. On a related note, the *disconnected layer* of ADO.NET (see Chapter 22) generates strongly typed `DataSet` objects to represent data from a given table in a relational database.

■ **Note** As you might know, building a SQL statement using string concatenation can be risky from a security point of view (think: SQL injection attacks). The preferred way to build command text is to use a parameterized query, which you will learn about shortly.

Adding the Deletion Logic

Deleting an existing record is as simple as inserting a new record. Unlike when you created the code for `InsertAuto()`, this time you will learn about an important `try/catch` scope that handles the possibility of attempting to delete a car that is currently on order for an individual in the `Customers` table. Add the following method to the `InventoryDAL` class type:

```
public void DeleteCar(int id)
{
    // Delete the car with the specified CarId
    string sql = $"Delete from Inventory where CarId = '{id}'";
    using (SqlCommand command = new SqlCommand(sql, _sqlConnection))
    {
        try
        {
            command.ExecuteNonQuery();
        }
        catch (SqlException ex)
        {
            Exception error = new Exception("Sorry! That car is on order!", ex);
        }
    }
}
```



```

        throw error;
    }
}

```

Adding the Update Logic

When it comes to the act of updating an existing record in the `Inventory` table, the first thing you must decide is what you want to allow the caller to change, whether it's the car's color, the pet name, the make, or all of the above. One way to give the caller complete flexibility is to define a method that takes a string type to represent any sort of SQL statement, but that is risky at best.

Ideally, you want to have a set of methods that allow the caller to update a record in a variety of ways. However, for this simple data access library, you will define a single method that allows the caller to update the pet name of a given automobile, like so:

```

public void UpdateCarPetName(int id, string newPetName)
{
    // Update the PetName of the car with the specified CarId.
    string sql = $"Update Inventory Set PetName = '{newPetName}' Where CarId = '{id}'";
    using (SqlCommand command = new SqlCommand(sql, _sqlConnection))
    {
        command.ExecuteNonQuery();
    }
}

```

Adding the Selection Logic

Next, you need to add a selection method. As you saw earlier in this chapter, a data provider's data reader object allows for a selection of records using a read-only, forward-only server-side cursor. As you call the `Read()` method, you can process each record in a fitting manner. While this is all well and good, you need to contend with the issue of how to return these records to the calling tier of your application.

One approach would be to populate and return a multidimensional array (or other such return value, such as a generic `List<NewCar>` object) with the data obtained by the `Read()` method. Here is a second way to obtain data from the `Inventory` table that uses the latter approach:

```

public List<NewCar> GetAllInventoryAsList()
{
    // This will hold the records.
    List<NewCar> inv = new List<NewCar>();

    // Prep command object.
    string sql = "Select * From Inventory";
    using (SqlCommand command = new SqlCommand(sql, _sqlConnection))
    {
        SqlDataReader dataReader = command.ExecuteReader();
        while (dataReader.Read())
        {
            inv.Add(new NewCar
            {

```

```

        CarId = (int)dataReader["CarId"],
        Color = (string)dataReader["Color"],
        Make = (string)dataReader["Make"],
        PetName = (string)dataReader["PetName"]
    });
}
dataReader.Close();
}
return inv;
}

```

Still another approach is to return a `System.Data.DataTable` object, which is actually part of the disconnected layer of ADO.NET. You will find complete coverage of the disconnected layer in the next chapter; however, for the time being, you should understand that a `DataTable` is a class type that represents a tabular block of data (e.g., a grid on a spreadsheet).

Internally, the `DataTable` class represents data as a collection of rows and columns. While you can fill these collections programmatically, the `DataTable` type provides a method named `Load()` that automatically populates these collections using a data reader object! Consider the following methods, which return data from `Inventory` as a `DataTable`:

```

public DataTable GetAllInventoryAsDataTable()
{
    // This will hold the records.
    DataTable dataTable = new DataTable();

    // Prep command object.
    string sql = "Select * From Inventory";
    using (SqlCommand cmd = new SqlCommand(sql, _sqlConnection))
    {
        SqlDataReader dataReader = cmd.ExecuteReader();
        // Fill the DataTable with data from the reader and clean up.
        dataTable.Load(dataReader);
        dataReader.Close();
    }
    return dataTable;
}

```

Working with Parameterized Command Objects

Currently, the insert, update, and delete logic for the `InventoryDAL` type uses hard-coded string literals for each SQL query. As you might know, you can use a *parameterized query* to treat SQL parameters as objects, rather than as a simple blob of text. Treating SQL queries in a more object-oriented manner helps reduce the number of typos (given strongly typed properties); plus, parameterized queries typically execute much faster than a literal SQL string because they are parsed exactly once (rather than each time the SQL string is assigned to the `CommandText` property). Parameterized queries also help protect against SQL injection attacks (a well-known data access security issue).

To support parameterized queries, ADO.NET command objects maintain a collection of individual parameter objects. By default, this collection is empty, but you can insert any number of parameter objects that map to a *placeholder parameter* in the SQL query. When you want to associate a parameter within a SQL query to a member in the command object's `parameters` collection, you can prefix the SQL text parameter with the `@` symbol (at least when using Microsoft SQL Server; not all DBMSs support this notation).

Specifying Parameters Using the DbParameter Type

Before you build a parameterized query, you need to familiarize yourself with the `DbParameter` type (which is the base class to a provider's specific parameter object). This class maintains a number of properties that allow you to configure the name, size, and data type of the parameter, as well as other characteristics, including the parameter's direction of travel. Table 21-7 describes some key properties of the `DbParameter` type.

Table 21-7. Key Members of the `DbParameter` Type

| Property | Meaning in Life |
|----------------------------|---|
| <code>DbType</code> | Gets or sets the native data type of the parameter, represented as a CLR data type |
| <code>Direction</code> | Gets or sets whether the parameter is input-only, output-only, bidirectional, or a return value parameter |
| <code>IsNullable</code> | Gets or sets whether the parameter accepts null values |
| <code>ParameterName</code> | Gets or sets the name of the <code>DbParameter</code> |
| <code>Size</code> | Gets or sets the maximum parameter size of the data in bytes; this is useful only for textual data |
| <code>Value</code> | Gets or sets the value of the parameter |

Now let's look at how to populate a command object's collection of `DbParameter`-compatible objects by reworking the following version of the `InsertAuto()` method to leverage parameter objects (you could perform a similar reworking for your remaining methods; however, that's not necessary for this example):

```
public void InsertAuto(int id, string color, string make, string petName)
{
    // Note the "placeholders" in the SQL query.
    string sql = "Insert Into Inventory" +
        "(Make, Color, PetName) Values" +
        "(@Make, @Color, @PetName)";

    // This command will have internal parameters.
    using (SqlCommand command = new SqlCommand(sql, _sqlConnection))
    {
        // Fill params collection.
        SqlParameter parameter = new SqlParameter
        {
            ParameterName = "@Make",
            Value = make,
            SqlDbType = SqlDbType.Char,
            Size = 10
        };
        command.Parameters.Add(parameter);

        parameter = new SqlParameter
        {
            ParameterName = "@Color",
            Value = color,
            SqlDbType = SqlDbType.Char,
```

```

        Size = 10
    };
    command.Parameters.Add(parameter);

    parameter = new SqlParameter
    {
        ParameterName = "@PetName",
        Value = petName,
        SqlDbType = SqlDbType.Char,
        Size = 10
    };
    command.Parameters.Add(parameter);

    command.ExecuteNonQuery();
}
}

```

Again, notice that your SQL query consists of four embedded placeholder symbols, each of which is prefixed with the @ token. You can use the `SqlParameter` type to map each placeholder using the `ParameterName` property and specify various details (e.g., its value, data type, and size) in a strongly typed matter. After each parameter object is hydrated, it is added to the command object's collection through a call to `Add()`.

■ **Note** This example uses various properties to establish a parameter object. Note, however, that parameter objects support a number of overloaded constructors that allow you to set the values of various properties (which will result in a more compact code base). Also be aware that Visual Studio provides many graphical designers that will generate a good deal of this grungy parameter-centric code on your behalf (see Chapters 22 and 23).

While building a parameterized query often requires more code, the end result is a more convenient way to tweak SQL statements programmatically, as well as to achieve better overall performance. While you are free to use this technique whenever a SQL query is involved, parameterized queries prove most helpful when you want to trigger a stored procedure.

Executing a Stored Procedure

Recall that a *stored procedure* is a named block of SQL code stored in the database. You can construct stored procedures so they return a set of rows or scalar data types or do anything else that makes sense (e.g., insert, update, or delete); you can also have them take any number of optional parameters. The end result is a unit of work that behaves like a typical function, except that it is located on a data store rather than a binary business object. Currently, your `AutoLot` database defines a single stored procedure named `GetPetName`, which you formatted as follows:

```

GetPetName
@carID int,
@petName char(10) output
AS
SELECT @petName = PetName from Inventory where CarId = @carID

```

Now consider the following final method of the InventoryDAL type, which invokes your stored procedure:

```
public string LookUpPetName(int carID)
{
    string carPetName;

    // Establish name of stored proc.
    using (SqlCommand command = new SqlCommand("GetPetName", _sqlConnection))
    {
        command.CommandType = CommandType.StoredProcedure;

        // Input param.
        SqlParameter param = new SqlParameter
        {
            ParameterName = "@carID",
            SqlDbType = SqlDbType.Int,
            Value = carID,
            Direction = ParameterDirection.Input
        };
        command.Parameters.Add(param);

        // Output param.
        param = new SqlParameter
        {
            ParameterName = "@petName",
            SqlDbType = SqlDbType.Char,
            Size = 10,
            Direction = ParameterDirection.Output
        };
        command.Parameters.Add(param);

        // Execute the stored proc.
        command.ExecuteNonQuery();

        // Return output param.
        carPetName = (string)command.Parameters["@petName"].Value;
    }
    return carPetName;
}
```

One important aspect of invoking a stored procedure is to keep in mind that a command object can represent a SQL statement (the default) or the name of a stored procedure. When you want to inform a command object that it will be invoking a stored procedure, you pass in the name of the procedure (as a constructor argument or by using the `CommandText` property) and must set the `CommandType` property to the value `CommandType.StoredProcedure`. (If you fail to do this, you will receive a runtime exception because the command object is expecting a SQL statement by default.)

```
SqlCommand command = new SqlCommand("GetPetName", _sqlConnection);
command.CommandType = CommandType.StoredProcedure;
```

Next, notice that the `Direction` property of a parameter object allows you to specify the direction of travel for each parameter passed to the stored procedure (e.g., input parameter, output parameter, in/out parameter, or return value). As before, you add each parameter object to the command object's parameters collection.

```
// Input param.
SqlParameter param = new SqlParameter
{
    ParameterName = "@carID",
    SqlDbType = SqlDbType.Int,
    Value = carID,
    Direction = ParameterDirection.Input
};
command.Parameters.Add(param);
```

After the stored procedure completes with a call to `ExecuteNonQuery()`, you can obtain the value of the output parameter by investigating the command object's parameter collection and casting accordingly.

```
// Return output param.
carPetName = (string)command.Parameters["@petName"].Value;
```

At this point, your initial iteration of the `AutoLotDAL.dll` data access library is complete! You can use this assembly to build any sort of front end to display and edit your data (e.g., console based, desktop GUI, or an HTML-based web application). You have not yet examined how to build graphical user interfaces, so next you will test your data library from a new console application.

■ **Source Code** You can find the `AutoLotDAL` project in the [Chapter 21](#) subdirectory.

Creating a Console UI–Based Front End

Create a new Console Application project named `AutoLotCUIClient`. After you create your new project, be sure to add a reference to your `AutoLotDAL.dll` assembly, as well as `System.Configuration.dll`. If you are using the sample code supplied with the book, you can reference the `AutoLotDAL` project from the [Chapter 21](#) subdirectory. If you are creating new solutions for each sample, navigate to your `AutoLotDAL` solution, and locate the `AutoLotDAL.dll` file in the `build` directory. Next, add the following using statements to your C# code file:

```
using AutoLotDAL.ConnectedLayer;
using AutoLotDAL.Models;
using System.Configuration;
using System.Data;
using static System.Console;
```

Open the `App.config` file in your project (or add a new one if one doesn't already exist) and add the `<connectionStrings>` element, which you will use to connect to your instance of the AutoLot database, as in this example:

```
<configuration>
  <connectionStrings>
    <add name="AutoLotSqlProvider" connectionString =
      "Data Source=(local)\SQLEXPRESS2014;
      Integrated Security=SSPI;Initial Catalog=AutoLot"/>
  </connectionStrings>
  <startup>
    <supportedRuntime version="v4.0" sku=".NETFramework,Version=v4.6" />
  </startup>
</configuration>
```

Implementing the `Main()` Method

The `Main()` method is responsible for prompting the user for a specific course of action and executing that request using a `switch` statement. This program allows the user to enter the following commands:

- I: Inserts a new record into the Inventory table
- U: Updates an existing record in the Inventory table
- D: Deletes an existing record from the Inventory table
- L: Displays the current inventory using a data reader
- S: Shows these options to the user
- P: Looks up pet name from carID
- Q: Quits the program

Each possible option is handled by a unique static method within the `Program` class. The next snippet shows the complete implementation of `Main()`. Notice that each method invoked from the `do/while` loop (with the exception of the `ShowInstructions()` method) takes an `InventoryDAL` object as its sole parameter.

```
static void Main(string[] args)
{
    WriteLine("***** The AutoLot Console UI *****\n");

    // Get connection string from App.config.
    string connectionString =
        ConfigurationManager.ConnectionStrings["AutoLotSqlProvider"].ConnectionString;
    bool userDone = false;
    string userCommand = "";

    // Create our InventoryDAL object.
    InventoryDAL invDAL = new InventoryDAL();
    invDAL.OpenConnection(connectionString);
```

```
// Keep asking for input until user presses the Q key.
try
{
    ShowInstructions();
    do
    {
        Write("\nPlease enter your command: ");
        userCommand = ReadLine();
        WriteLine();
        switch (userCommand?.ToUpper()?? "")
        {
            case "I":
                InsertNewCar(invDAL);
                break;
            case "U":
                UpdateCarPetName(invDAL);
                break;
            case "D":
                DeleteCar(invDAL);
                break;
            case "L":
                ListInventory(invDAL);
                break;
            case "S":
                ShowInstructions();
                break;
            case "P":
                LookUpPetName(invDAL);
                break;
            case "Q":
                userDone = true;
                break;
            default:
                WriteLine("Bad data! Try again");
                break;
        }
    } while (!userDone);
}
catch (Exception ex)
{
    WriteLine(ex.Message);
}
finally
{
    invDAL.CloseConnection();
}
}
```

Implementing the ShowInstructions() Method

The ShowInstructions() method does what you would expect, as shown here:

```
private static void ShowInstructions()
{
    WriteLine("I: Inserts a new car.");
    WriteLine("U: Updates an existing car.");
    WriteLine("D: Deletes an existing car.");
    WriteLine("L: Lists current inventory.");
    WriteLine("S: Shows these instructions.");
    WriteLine("P: Looks up pet name.");
    WriteLine("Q: Quits program.");
}
```

Implementing the ListInventory() Method

You could implement the ListInventory() method in either of two ways, based on how you constructed your data access library. Recall that the GetAllInventoryAsDataTable() method of InventoryDAL returns a DataTable object. You could implement this approach like this:

```
private static void ListInventory(InventoryDAL invDAL)
{
    // Get the list of inventory.
    DataTable dt = invDAL.GetAllInventoryAsDataTable();
    // Pass DataTable to helper function to display.
    DisplayTable(dt);
}
```

The DisplayTable() helper method displays the table data using the Rows and Columns properties of the incoming DataTable (again, you will learn the full details of the DataTable object the next chapter, so don't fret over the details).

```
private static void DisplayTable(DataTable dt)
{
    // Print out the column names.
    for (int curCol = 0; curCol < dt.Columns.Count; curCol++)
    {
        Write($"{dt.Columns[curCol].ColumnName}\t");
    }
    WriteLine("\n-----");

    // Print the DataTable.
    for (int curRow = 0; curRow < dt.Rows.Count; curRow++)
    {
        for (int curCol = 0; curCol < dt.Columns.Count; curCol++)
        {
            Write($"{dt.Rows[curRow][curCol]}\t");
        }
        WriteLine();
    }
}
```

If you would prefer to call the `GetAllInventoryAsList()` method of `InventoryDAL`, you could implement a method named `ListInventoryViaList()`, like so (you will need to add a `using` for `AutoLotDAL.Models`):

```
private static void ListInventoryViaList(InventoryDAL invDAL)
{
    // Get the list of inventory.
    List<NewCar> record = invDAL.GetAllInventoryAsList();

    WriteLine("CarId:\tMake:\tColor:\tPetName:");
    foreach (NewCar c in record)
    {
        WriteLine($"{c.CarId}\t{c.Make}\t{c.Color}\t{c.PetName}");
    }
}
```

Implementing the `DeleteCar()` Method

Deleting an existing automobile is as simple as asking the user for the ID of the car and passing this to the `DeleteCar()` method of the `InventoryDAL` type, as shown here:

```
private static void DeleteCar(InventoryDAL invDAL)
{
    // Get ID of car to delete.
    Write("Enter ID of Car to delete: ");
    int id = int.Parse(ReadLine()??"0");

    // Just in case you have a referential integrity violation!
    try
    {
        invDAL.DeleteCar(id);
    }
    catch(Exception ex)
    {
        WriteLine(ex.Message);
    }
}
```

Implementing the `InsertNewCar()` Method

Inserting a new record into the `Inventory` table is a simple matter of asking the user for the new bits of data (using `ReadLine()` calls) and passing this data into the `InsertAuto()` method of `InventoryDAL`, like so:

```
private static void InsertNewCar(InventoryDAL invDAL)
{
    Write("Enter Car ID: ");
    var newCarId = int.Parse(ReadLine()??"0");
    Write("Enter Car Color: ");
    var newCarColor = ReadLine();
    Write("Enter Car Make: ");
    var newCarMake = ReadLine();
}
```

```

Write("Enter Pet Name: ");
var newCarPetName = ReadLine();

// Now pass to data access library.
invDAL.InsertAuto(newCarId, newCarColor, newCarMake, newCarPetName);
}

```

Recall that you overloaded `InsertAuto()` to take a `NewCar` object, rather than a set of independent arguments. Thus, you could have implemented `InsertNewCar()` like this:

```

private static void InsertNewCar(InventoryDAL invDAL)
{
    // First get the user data.
    ..//omitted for brevity
    // Now pass to data access library.
    var c = new NewCar
    {
        CarId = newCarId,
        Color = newCarColor,
        Make = newCarMake,
        PetName = newCarPetName
    };
    invDAL.InsertAuto(c);
}

```

Implementing the `UpdateCarPetName()` Method

The following implementation of `UpdateCarPetName()` looks similar:

```

private static void UpdateCarPetName(InventoryDAL invDAL)
{
    // First get the user data.
    Write("Enter Car ID: ");
    var carID = int.Parse(ReadLine()??"0");
    Write("Enter New Pet Name: ");
    var newCarPetName = ReadLine();

    // Now pass to data access library.
    invDAL.UpdateCarPetName(carID, newCarPetName);
}

```

Implementing `LookUpPetName()`

Obtaining the pet name of a given automobile works similarly to the previous methods; this is because the data access library encapsulates all the lower-level ADO.NET calls.

```

private static void LookUpPetName(InventoryDAL invDAL)
{
    // Get ID of car to look up.
    Write("Enter ID of Car to look up: ");
    int id = int.Parse(ReadLine()??"0");
    WriteLine($"Petname of {id} is {invDAL.LookUpPetName(id).TrimEnd()}.");
}

```

With this, your console-based front end is finished! It's time to run your program and test each method. Here is some partial output that tests the L, P, and Q commands:

```
***** The AutoLot Console UI *****
```

```
I: Inserts a new car.
U: Updates an existing car.
D: Deletes an existing car.
L: Lists current inventory.
S: Shows these instructions.
P: Looks up pet name.
Q: Quits program.
```

```
Please enter your command: L
```

```
CarId:  Make:   Color:  PetName:
1      VW      Black   Zippy
2      Ford     Rust    Rusty
3      Saab     Black   Mel
4      Yugo     Yellow  Clunker
5      BMW      Black   Bimmer
6      BMW      Green   Hank
7      BMW      Pink    Pinkey
```

```
Please enter your command: P
```

```
Enter ID of Car to look up: 6
Petname of 6 is Hank.
```

```
Please enter your command: Q
```

```
Press any key to continue . . .
```

■ **Source Code** You can find the AutoLotCUIClient application in the [Chapter 21](#) subdirectory.

Understanding Database Transactions

Let's wrap up this examination of the connected layer of ADO.NET by taking a look at the concept of a database transaction. Simply put, a *transaction* is a set of database operations that must either *all* work or *all* fail as a collective unit. As you might imagine, transactions are quite important to ensure that table data is safe, valid, and consistent.

Transactions are important when a database operation involves interacting with multiple tables or multiple stored procedures (or a combination of database atoms). The classic transaction example involves the process of transferring monetary funds between two bank accounts. For example, if you were to

transfer \$500 from your savings account into your checking account, the following steps should occur in a transactional manner:

1. The bank should remove \$500 from your savings account.
2. The bank should add \$500 to your checking account.

It would be an extremely bad thing if the money were removed from the savings account but not transferred to the checking account (because of some error on the bank's part) because then you would be out \$500! However, if these steps are wrapped up into a database transaction, the DBMS ensures that all related steps occur as a single unit. If any part of the transaction fails, the entire operation is *rolled back* to the original state. On the other hand, if all steps succeed, the transaction is *committed*.

■ **Note** You might be familiar with the acronym ACID from looking at transactional literature. This represents the four key properties of a prim-and-proper transaction: *Atomic* (all or nothing), *Consistent* (data remains stable throughout the transaction), *Isolated* (transactions do not step on each other's feet), and *Durable* (transactions are saved and logged).

It turns out that the .NET platform supports transactions in a variety of ways. This chapter will look at the transaction object of your ADO.NET data provider (`SqlTransaction`, in the case of `System.Data.SqlClient`). The .NET base class libraries also provide transactional support within numerous APIs, including the following:

- `System.EnterpriseServices`: This namespace (located in the `System.EnterpriseServices.dll` assembly) provides types that allow you to integrate with the COM+ runtime layer, including its support for distributed transactions.
- `System.Transactions`: This namespace (located in the `System.Transactions.dll` assembly) contains classes that allow you to write your own transactional applications and resource managers for a variety of services (e.g., MSMQ, ADO.NET, and COM+).
- *Windows Communication Foundation*: The WCF API provides services to facilitate transactions with various distributed binding classes.
- *Windows Workflow Foundations*: The WF API provides transactional support for workflow activities.

In addition to the baked-in transactional support within the .NET base class libraries, it is possible to use the SQL language of your database management system. For example, you could author a stored procedure that uses the `BEGIN TRANSACTION`, `ROLLBACK`, and `COMMIT` statements.

Key Members of an ADO.NET Transaction Object

While transactional-aware types exist throughout the base class libraries, you will focus on transaction objects found within an ADO.NET data provider, all of which derive from `DBTransaction` and implement the `IDbTransaction` interface. Recall from the beginning of this chapter that `IDbTransaction` defines a handful of members as follows:

```
public interface IDbTransaction : IDisposable
{
    IDbConnection Connection { get; }
    IsolationLevel IsolationLevel { get; }
```

```

void Commit();
void Rollback();
}

```

Notice the `Connection` property, which returns a reference to the connection object that initiated the current transaction (as you'll see, you obtain a transaction object from a given connection object). You call the `Commit()` method when each of your database operations have succeeded. Doing this causes each of the pending changes to be persisted in the data store. Conversely, you can call the `Rollback()` method in the event of a runtime exception, which informs the DMBS to disregard any pending changes, leaving the original data intact.

■ **Note** The `IsolationLevel` property of a transaction object allows you to specify how aggressively a transaction should be guarded against the activities of other parallel transactions. By default, transactions are isolated completely until committed. Consult the .NET Framework 4.6 SDK documentation for full details regarding the values of the `IsolationLevel` enumeration.

Beyond the members defined by the `IDbTransaction` interface, the `SqlTransaction` type defines an additional member named `Save()`, which allows you to define *save points*. This concept allows you to roll back a failed transaction up until a named point, rather than rolling back the entire transaction. Essentially, when you call `Save()` using a `SqlTransaction` object, you can specify a friendly string moniker. When you call `Rollback()`, you can specify this same moniker as an argument to perform an effective *partial rollback*. Calling `Rollback()` with no arguments causes all the pending changes to be rolled back.

Adding a CreditRisks Table to the AutoLot Database

Now let's look at how you use ADO.NET transactions. Begin by using the Server Explorer of Visual Studio to add a new table named `CreditRisks` to the AutoLot database, which has the same columns as the `Customers` table you created earlier in this chapter: `CustID`, which is the primary key; `FirstName`; and `LastName`. As its name suggests, `CreditRisks` is where you banish the undesirable customers who fail a credit check (see Figure 21-15).



Figure 21-15. The interconnected `Orders`, `Inventory`, and `Customers` tables

Like the earlier savings-to-checking money transfer example, this example, where you move a risky customer from the `Customers` table into the `CreditRisks` table, should occur under the watchful eye of a transactional scope (after all, you will want to remember the names of those who are not creditworthy). Specifically, you need to ensure that *either* that you successfully delete the current credit risks from the `Customers` table and add them to the `CreditRisks` table or that neither of these database operations occurs.

■ **Note** In a production environment, you would not need to build a whole new database table to capture high-risk customers; instead, you could add a Boolean column named `IsCreditRisk` to the existing `Customers` table. However, this new table lets you play with a simple transaction.

Adding a Transaction Method to InventoryDAL

Now let's look at how you work with ADO.NET transactions programmatically. Begin by opening the `AutoLotDAL` code library project you created earlier and add a new public method named `ProcessCreditRisk()` to the `InventoryDAL` class to deal with perceived a credit risks. (Note that this example avoids using a parameterized query to keep the implementation simple; however, you'd want use such a query for a production-level method.)

```
// A new member of the InventoryDAL class.
public void ProcessCreditRisk(bool throwEx, int custID)
{
    // First, look up current name based on customer ID.
    string fName;
    string lName;
    var cmdSelect =
        new SqlCommand($"Select * from Customers where CustId = {custID}",
            _sqlConnection);
    using (var dataReader = cmdSelect.ExecuteReader())
    {
        if (dataReader.HasRows)
        {
            dataReader.Read();
            fName = (string) dataReader["FirstName"];
            lName = (string) dataReader["LastName"];
        }
        else
        {
            return;
        }
    }

    // Create command objects that represent each step of the operation.
    var cmdRemove =
        new SqlCommand($"Delete from Customers where CustId = {custID}",
            _sqlConnection);
```

```

var cmdInsert =
    new SqlCommand("Insert Into CreditRisks" +
        $"{(FirstName, LastName) Values('{fName}', '{lName}')}",
        _sqlConnection);

// We will get this from the connection object.
SqlTransaction tx = null;
try
{
    tx = _sqlConnection.BeginTransaction();

    // Enlist the commands into this transaction.
    cmdInsert.Transaction = tx;
    cmdRemove.Transaction = tx;

    // Execute the commands.
    cmdInsert.ExecuteNonQuery();
    cmdRemove.ExecuteNonQuery();

    // Simulate error.
    if (throwEx)
    {
        throw new Exception("Sorry! Database error! Tx failed...");
    }

    // Commit it!
    tx.Commit();
}
catch (Exception ex)
{
    WriteLine(ex.Message);
    // Any error will roll back transaction.
    // Using the new conditional access operator to check for null.
    tx?.Rollback();
}
}

```

Here, you use an incoming `bool` parameter to represent whether you will throw an arbitrary exception when you attempt to process the offending customer. This allows you to simulate an unforeseen circumstance that will cause the database transaction to fail. Obviously, you do this here only for illustrative purposes; a true database transaction method would not want to allow the caller to force the logic to fail on a whim!

Note that you use two `SqlCommand` objects to represent each step in the transaction you will kick off. After you obtain the customer's first and last names based on the incoming `custID` parameter, you can obtain a valid `SqlTransaction` object from the connection object using `BeginTransaction()`. Next, and most importantly, you must *enlist each command object* by assigning the `Transaction` property to the transaction object you have just obtained. If you fail to do so, the `Insert/Delete` logic will not be under a transactional context.

After you call `ExecuteNonQuery()` on each command, you throw an exception if (and only if) the value of the `bool` parameter is `true`. In this case, all pending database operations are rolled back. If you do not throw an exception, both steps will be committed to the database tables once you call `Commit()`. Now compile your modified `AutoLotDAL` project to ensure you do not have any typos.

Testing Your Database Transaction

You could update your previous `AutoLotCUIClient` application with a new option to invoke the `ProcessCreditRisk()` method; instead, however, you will create a new Console Application project named `AdoNetTransaction` to accomplish this. Set a reference to your `AutoLotDAL.dll` assembly and import the `AutoLotDAL.ConnectedLayer`, `AutoLotDAL.Models`, and static `System.Console` namespaces.

Next, open your `Customers` table for data entry by right-clicking the table icon from the Server Explorer and selecting `Show Table Data`. Now add the following new customer who will be the victim of a low credit score (make a note of the assigned `Id` for the new record):

- `FirstName`: Homer
- `LastName`: Simpson

Finally, update your `Main()` method as follows:

```
static void Main(string[] args)
{
    WriteLine("***** Simple Transaction Example *****\n");

    // A simple way to allow the tx to succeed or not.
    bool throwEx = true;

    Write("Do you want to throw an exception (Y or N): ");
    var userAnswer = ReadLine();
    if (userAnswer?.ToLower() == "n")
    {
        throwEx = false;
    }

    var dal = new InventoryDAL();
    dal.OpenConnection(@"Data Source=(local)\SQLEXPRESS2014;Integrated Security=SSPI;" +
        "Initial Catalog=AutoLot");

    // Process customer 5 - enter the id for Homer Simpson in the next line.
    dal.ProcessCreditRisk(throwEx, 5);
    WriteLine("Check CreditRisk table for results");
    ReadLine();
}
```

If you were to run your program and elect to throw an exception, you would find that Homer is *not* removed from the `Customers` table because the entire transaction has been rolled back. However, if you did not throw an exception, you would find that Customer ID 5 is no longer in the `Customers` table and has been placed in the `CreditRisks` table instead.

■ **Source Code** You can find the `AdoNetTransaction` project in the Chapter 21 subdirectory.

Summary

ADO.NET is the native data access technology of the .NET platform, and you can use it in three distinct manners: connected, disconnected, or through the Entity Framework. In this chapter, you examined the connected layer and learned the role of data providers, which are essentially concrete implementations of several abstract base classes (in the `System.Data.Common` namespace) and interface types (in the `System.Data` namespace). You also saw that it is possible to build a provider-neutral code base using the ADO.NET data provider factory model.

You also learned that you can use connection objects, transaction objects, command objects, and data reader objects of the connected layer to select, update, insert, and delete records. Also, recall that command objects support an internal parameter collection, which you can use to add some type safety to your SQL queries; these also prove quite helpful when triggering stored procedures.

CHAPTER 22



ADO.NET Part II: The Disconnected Layer

The previous chapter gave you a chance to examine the connected layer and the foundational components of ADO.NET, which allow you to submit SQL statements to a database using the connection, command, and data reader objects of your data provider. In this chapter, you will learn about the *disconnected layer* of ADO.NET. Using this facet of ADO.NET lets you model database data in memory, within the calling tier, by leveraging numerous members of the `System.Data` namespace (most notably, `DataSet`, `DataTable`, `DataRow`, `DataColumn`, `DataView`, and `DataRelation`). By doing so, you can provide the illusion that the calling tier is continuously connected to an external data source; the reality is that the caller is operating on a local copy of relational data.

■ **Note** As mentioned in the introduction of the previous chapter, the Entity Framework (EF) is gaining momentum and is seeing increased adoption. I will cover EF in the next chapter, but it's still important to know how ADO.NET works at its core, since EF (and the other .NET object-relational mappers [ORMs]) are built on top of ADO.NET. While it is possible to use this *disconnected* aspect of ADO.NET without ever making a literal connection to a relational database, you will most often obtain populated `DataSet` objects using the data adapter object of your data provider. As you will see, data adapter objects function as a bridge between the client tier and a relational database. Using these objects, you can obtain `DataSet` objects, manipulate their contents, and send modified rows back for processing. The end result is a highly scalable data-centric .NET application.

This chapter will also illustrate some data-binding techniques, using the context of a Windows Forms GUI desktop application, and examine the role of a *strongly typed DataSet*. You will also update the `AutoLotDAL.dll` data library you created in Chapter 21 with a new namespace that uses the disconnected layer of ADO.NET. Last but not least, you will learn about the role of LINQ to `DataSet`, which allows you to apply LINQ queries to your in-memory data cache.

■ **Note** You will learn about various data-binding techniques for Windows Presentation Foundation and ASP.NET applications later in this book.

Understanding the Disconnected Layer of ADO.NET

As you saw in the previous chapter, working with the connected layer allows you to interact with a database using the primary connection, command, and data reader objects. You can use this handful of classes to select, insert, update, and delete records to your heart's content (as well as invoke stored procedures or perform other data operations [e.g., DDL to create table and DCL to grant permissions]). However, you have seen only part of the ADO.NET story. Recall that you can use the ADO.NET object model in a disconnected manner.

Using the disconnected layer, it is possible to model relational data using an in-memory object model. Far beyond simply modeling a tabular block of rows and columns, the types within `System.Data` allow you to represent table relationships, column constraints, primary keys, views, and other database primitives. After you model the data, you can apply filters, submit in-memory queries, and persist (or load) your data in XML and binary formats. You can do all of this without ever making a literal connection to a DBMS (which is why it's called a *disconnected layer*) by loading data from a local XML file or manually building a `DataSet` in code.

■ **Note** In Chapter 23, you will examine the ADO.NET Entity Framework, which builds upon the concepts found in the disconnected layer examined here.

You could use the disconnected types without ever connecting to a database, but you will typically still use connection and command objects. In addition, you will leverage a specific object, the *data adapter* (which extends the abstract `DbDataAdapter` class), to fetch and update data. Unlike the connected layer, data obtained with a data adapter is not processed using data reader objects. Rather, data adapter objects use `DataSet` objects (or more specifically, the `DataTable` objects in a `DataSet`) to move data between the caller and data source. The `DataSet` type is a container for any number of `DataTable` objects, each of which contains a collection of `DataRow` and `DataColumn` objects.

The data adapter object of your data provider handles the database connection automatically. In an effort to increase scalability, data adapters keep the connection open for the shortest amount of time possible. After the caller receives the `DataSet` object, the calling tier is completely disconnected from the database and left with a local copy of the remote data. The caller is free to insert, delete, or update rows from a given `DataTable`, but the physical database is not updated until the caller explicitly passes a `DataTable` in the `DataSet` to the data adapter for updating. In a nutshell, `DataSet`s allow the clients to pretend they are always connected; however, they actually operate on an in-memory database (see Figure 22-1).

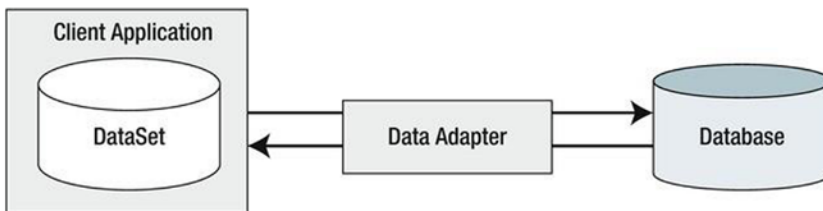

Figure 22-1. Data adapter objects move `DataSet`s to and from the client tier

Given that the centerpiece of the disconnected layer is the `DataSet` class, the first task of this chapter is to learn how to manipulate a `DataSet` manually. Once you can do this, you will have no problem manipulating the contents of a `DataSet` retrieved from a data adapter object.

Understanding the Role of the DataSet

As noted previously, a `DataSet` is an in-memory representation of relational data. More specifically, a `DataSet` is a class type that internally maintains three strongly typed collections (see Figure 22-2).

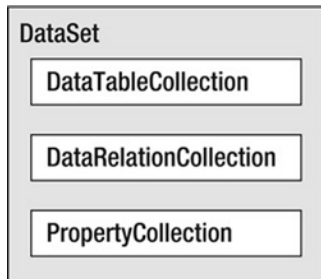

Figure 22-2. *The anatomy of a DataSet*

The `Tables` property of the `DataSet` allows you to access the `DataTableCollection` that contains the individual `DataTables`. Another important collection used by the `DataSet` is `DataRelationCollection`. Given that a `DataSet` is a disconnected version of a database schema, you can use it to represent the parent-child relationships programmatically between its tables. For example, you can create a relation between two tables to model a foreign key constraint using the `DataRelation` type. You can add this object to the `DataRelationCollection` with the `Relations` property. At this point, you can navigate between the related tables as you search for data. You will see how to do this later in the chapter.

The `ExtendedProperties` property provides access to the `PropertyCollection` object, which allows you to associate any extra information to the `DataSet` as name-value pairs. This information can be literally anything, even if it has no bearing on the database data itself. For example, you can associate your company's name to a `DataSet`, which can then function as in-memory metadata. Other examples of extended properties might include time stamps, an encrypted password that must be supplied to access the contents of the `DataSet`, a number representing a data refresh rate, and so forth.

■ **Note** The `DataTable` and `DataColumn` classes also support the `ExtendedProperties` property.

Key Properties of the DataSet

Before exploring too many other programmatic details, let's take a look at some core members of the `DataSet`. Table 22-1 describes some additional properties of interest beyond the `Tables`, `Relations`, and `ExtendedProperties` properties.

Table 22-1. *Properties of the DataSet*

| Property | Meaning in Life |
|--------------------|---|
| CaseSensitive | Indicates whether string comparisons in DataTable objects are case sensitive (or not). The default is false (string comparisons are not case sensitive by default). |
| DataSetName | Represents the friendly name of this DataSet. Typically, you establish this value as a constructor parameter. |
| EnforceConstraints | Gets or sets a value indicating whether constraint rules are followed when attempting any update operations (the default is true). |
| HasErrors | Gets a value indicating whether there are errors in any of the rows in any of the DataTables of the DataSet. |
| RemotingFormat | Allows you to define how the DataSet should serialize its content (binary or XML, which is the default). |

Key Methods of the DataSet

The methods of the DataSet work in conjunction with some of the functionality provided by the aforementioned properties. In addition to interacting with XML streams, the DataSet provides methods that allow you to copy the contents of your DataSet, navigate between the internal tables, and establish the beginning and ending points of a batch of updates. Table 22-2 describes some core methods.

Table 22-2. *Select Methods of the DataSet*

| Methods | Meaning in Life |
|-----------------|--|
| AcceptChanges() | Commits all the changes made to this DataSet since it was loaded or the last time AcceptChanges() was called. |
| Clear() | Completely clears the DataSet data by removing every row in each DataTable. |
| Clone() | Clones the structure, but not the data, of the DataSet, including all DataTables, as well as all relations and any constraints. |
| Copy() | Copies both the structure and data for this DataSet. |
| GetChanges() | Returns a copy of the DataSet containing all changes made to it since it was last loaded or since AcceptChanges() was called. This method is overloaded so that you can get just the new rows, just the modified rows, or just the deleted rows. |
| HasChanges() | Gets a value indicating whether the DataSet has changes, including new, deleted, or modified rows. |
| Merge() | Merges this DataSet with a specified DataSet. |
| ReadXml() | Allows you to define the structure of a DataSet object and populate it with data, based on XML schema and data read from a stream. |
| RejectChanges() | Rolls back all the changes made to this DataSet since it was created or since the last time AcceptChanges() was called. |
| WriteXml() | Allows you to write out the contents of a DataSet into a valid stream. |

Building a DataSet

Now that you have a better understanding of the role of the DataSet (and some idea of what you can do with one), create a new Console Application project named SimpleDataSet and import the System.Data namespace. Within the Main() method, define a new DataSet object that contains three extended properties that represent a time stamp, a unique identifier (represented as a System.Guid type), and your company's name, as follows (you also need to add using static System.Console;):

```
using static System.Console;
static void Main(string[] args)
{
    WriteLine("***** Fun with DataSets *****\n");

    // Create the DataSet object and add a few properties.
    var carsInventoryDS = new DataSet("Car Inventory");

    carsInventoryDS.ExtendedProperties["TimeStamp"] = DateTime.Now;
    carsInventoryDS.ExtendedProperties["DataSetID"] = Guid.NewGuid();
    carsInventoryDS.ExtendedProperties["Company"] =
        "Mikko's Hot Tub Super Store";

    FillDataSet(carsInventoryDS);
    PrintDataSet(carsInventoryDS);

    ReadLine();
}
```

■ **Note** A GUID (aka a globally unique identifier) is a statically unique 128-bit number.

A DataSet object is not terribly interesting until you insert any number of DataTables. Therefore, the next task is to examine the internal composition of the DataTable, beginning with the DataColumn type.

Working with DataColumnns

The DataColumn type represents a single column within a DataTable. Collectively speaking, the set of all DataColumn types bound to a given DataTable represents the foundation of a table's *schema* information. For example, if you were to model the Inventory table of the AutoLot database (see Chapter 21), you would create four DataColumnns, one for each column (CarID, Make, Color, and PetName). After you create your DataColumn objects, you typically add them into the columns collection of the DataTable type (using the Columns property).

Based on your background, you might know that you can assign a given column in a database table a set of constraints (e.g., configured as a primary key, assigned a default value, or configured to contain read-only information). Also, every column in a table must map to an underlying data type. For example, the Inventory table's schema requires that the CarID column map to an integer, while Make, Color, and PetName map to an array of characters. The DataColumn class has numerous properties that allow you to configure precisely these things. Table 22-3 provides a rundown of some core properties.

Table 22-3. *Properties of the DataColumn*

| Properties | Meaning in Life |
|-------------------|--|
| AllowDBNull | You use this property to indicate whether a row can specify null values in this column. The default value is true. |
| AutoIncrement | You use these properties to configure the autoincrement behavior for a given column. This can be helpful when you want to ensure unique values in a given DataColumn (such as a primary key). By default, a DataColumn does not support autoincrement behavior. |
| AutoIncrementSeed | |
| AutoIncrementStep | |
| Caption | This property gets or sets the caption you want to display for this column. This allows you to define a user-friendly version of a literal database column name. |
| ColumnMapping | This property determines how a DataColumn is represented when a DataSet is saved as an XML document using the DataSet.WriteXml() method. You can specify that the data column should be written out as an XML element, an XML attribute, simple text content, or ignored altogether. |
| ColumnName | This property gets or sets the name of the column in the Columns collection (meaning how it is represented internally by the DataTable). If you do not set the ColumnName explicitly, the default values are Column with (n+1) numerical suffixes (e.g., Column1, Column2, and Column3). |
| DataType | This property defines the data type (e.g., Boolean, string, or float) stored in the column. |
| DefaultValue | This property gets or sets the default value assigned to this column when you insert new rows. |
| Expression | This property gets or sets the expression used to filter rows, calculate a column's value, or create an aggregate column. |
| Ordinal | This property gets the numerical position of the column in the Columns collection maintained by the DataTable. |
| ReadOnly | This property determines whether this column is read-only, once a row has been added to the table. The default is false. |
| Table | This property gets the DataTable that contains this DataColumn. |
| Unique | This property gets or sets a value indicating whether the values in each row of the column must be unique or if repeating values are permissible. If you assign a column a primary key constraint, then you must set the Unique property to true. |

Building a DataColumn

To continue with the SimpleDataSet project (and illustrate the use of the DataColumn), assume you would like to model the columns of the Inventory table. Given that the CarID column will be the table's primary key, you will configure this DataColumn object as read-only, unique, and non-null (using the ReadOnly, Unique, and AllowDBNull properties). Next, update the Program class with a new method named FillDataSet(), which you use to build four DataColumn objects. Note this method takes a DataSet object as its only parameter.

```

static void FillDataSet(DataSet ds)
{
    // Create data columns that map to the
    // "real" columns in the Inventory table
    // of the AutoLot database.
    var carIDColumn = new DataColumn("CarID", typeof (int))
    {
        Caption = "Car ID",
        ReadOnly = true,
        AllowDBNull = false,
        Unique = true,
    };

    var carMakeColumn = new DataColumn("Make", typeof (string));
    var carColorColumn = new DataColumn("Color", typeof (string));
    var carPetNameColumn = new DataColumn("PetName", typeof (string))
    { Caption = "Pet Name"};
}

```

Notice that when you configure the `carIDColumn` object, you assign a value to the `Caption` property. This property is helpful because it allows you to define a string value for display purposes, which can be distinct from the literal database table column name (column names in a literal database table are typically better suited for programming purposes [e.g., `au_fname`] than display purposes [e.g., `Author First Name`]). Here, you set the caption for the `PetName` column for the same reason, because *Pet Name* looks nicer than *PetName* to the end user.

Enabling Autoincrementing Fields

One aspect of the `DataColumn` you can choose to configure is its ability to *autoincrement*. You use an autoincrementing column to ensure that when a new row is added to a given table, the value of this column is assigned automatically, based on the current step of the increase. This can be helpful when you want to ensure that a column has no repeating values (e.g., a primary key).

You control this behavior using the `AutoIncrement`, `AutoIncrementSeed`, and `AutoIncrementStep` properties. You use the seed value to mark the starting value of the column; you use the step value to identify the number to add to the seed when incrementing. Consider the following update to the construction of the `carIDColumn` `DataColumn`:

```

static void FillDataSet(DataSet ds)
{
    var carIDColumn = new DataColumn("CarID", typeof (int))
    {
        Caption = "Car ID",
        ReadOnly = true,
        AllowDBNull = false,
        Unique = true,
        AutoIncrement = true,
        AutoIncrementSeed = 1,
        AutoIncrementStep = 1
    };
}

```

Here, you configure the `carIDColumn` object to ensure that, as rows are added to the respective table, the value for this column is incremented by 1. You set the seed at 1, so this column would be numbered 1, 2, 3, 4, and so forth.

Adding DataColumn Objects to a DataTable

The `DataColumn` type does not typically exist as a stand-alone entity; however, you do typically insert it into a related `DataTable`. For example, create a new `DataTable` object (fully detailed in a moment) and insert each `DataColumn` object in the `Columns` collection using the `Columns` property, like so:

```
static void FillDataSet(DataSet ds):
{
...
// Now add DataColumnns to a DataTable.
var inventoryTable = new DataTable("Inventory");
inventoryTable.Columns.AddRange(new[]
{carIDColumn, carMakeColumn, carColorColumn, carPetNameColumn});
}
```

At this point, the `DataTable` object contains four `DataColumn` objects that represent the schema of the in-memory `Inventory` table. However, the table is currently devoid of data, and the table is currently outside of the table collection maintained by the `DataSet`. You will deal with both of these shortcomings, beginning by populating the table with data using `DataRow` objects.

Working with DataRows

As you have seen, a collection of `DataColumn` objects represents the schema of a `DataTable`. In contrast, a collection of `DataRow` objects represents the actual data in the table. Thus, if you have 20 rows in the `Inventory` table of the `AutoLot` database, you can represent these records using 20 `DataRow` objects.

Table 22-4 documents some (but not all) of the members of the `DataRow` type.

Table 22-4. Key Members of the DataRow Type

| Members | Meaning in Life |
|--|--|
| HasErrors GetColumnsInError() GetColumnError() ClearErrors() RowError | The HasErrors property returns a Boolean value indicating whether there are errors in a DataRow. If so, you can use the GetColumnsInError() method to obtain the offending columns and GetColumnError() to obtain the error description. Similarly, you can use the ClearErrors() method to remove each error listing for the row. The RowError property allows you to configure a textual description of the error for a given row. |
| ItemArray | This property gets or sets all the column values for this row using an array of objects. |
| RowState | You use this property to pinpoint the current <i>state</i> of the DataRow in the DataTable containing the DataRow, using values of the RowState enumeration (e.g., a row can be flagged as new, modified, unchanged, or deleted). |
| Table | You use this property to obtain a reference to the DataTable containing this DataRow. |
| AcceptChanges() RejectChanges() | These methods commit or reject all changes made to this row since the last time AcceptChanges() was called. |
| BeginEdit() EndEdit() CancelEdit() | These methods begin, end, or cancel an edit operation on a DataRow object. |
| Delete() | This method marks a row you want to remove when the AcceptChanges() method is called. |
| IsNull() | This method gets a value indicating whether the specified column contains a null value. |

Working with a DataRow is a bit different from working with a DataColumn; you cannot create a direct instance of this type because there is no public constructor.

```
// Error! No public constructor!
DataRow r = new DataRow();
```

Instead, you obtain a new DataRow object from a given DataTable. For example, assume you want to insert two rows in the Inventory table. The DataTable.NewRow() method allows you to obtain the next slot in the table, at which point you can fill each column with new data using the type indexer. When doing so, you can specify either the string name assigned to the DataColumn or its (zero-based) ordinal position.

```
static void FillDataSet(DataSet ds)
{
    ...
    // Now add some rows to the Inventory Table.
    DataRow carRow = inventoryTable.NewRow();
    carRow["Make"] = "BMW";
    carRow["Color"] = "Black";
    carRow["PetName"] = "Hamlet";
    inventoryTable.Rows.Add(carRow);
}
```

```

carRow = inventoryTable.NewRow();
// Column 0 is the autoincremented ID field,
// so start at 1.
carRow[1] = "Saab";
carRow[2] = "Red";
carRow[3] = "Sea Breeze";
inventoryTable.Rows.Add(carRow);
}

```

■ **Note** If you pass the `DataRow`'s indexer method an invalid column name or ordinal position, you will receive a runtime exception.

At this point, you have a single `DataTable` containing two rows. Of course, you can repeat this general process to create a number of `DataTables` to define the schema and data content. Before you insert the `inventoryTable` object into your `DataSet` object, you should check out the all-important `RowState` property.

Understanding the RowState Property

The `RowState` property is useful when you need to identify programmatically the set all rows in a table that have changed from their original value, have been newly inserted, and so forth. You can assign this property any value from the `DataRowState` enumeration, as shown in Table 22-5.

Table 22-5. Values of the `DataRowState` Enumeration

| Value | Meaning in Life |
|-----------|--|
| Added | The row has been added to a <code>DataRowCollection</code> , and <code>AcceptChanges()</code> has not been called. |
| Deleted | The row has been marked for deletion using the <code>Delete()</code> method of the <code>DataRow</code> , and <code>AcceptChanges()</code> has not been called. |
| Detached | The row has been created but is not part of any <code>DataRowCollection</code> . A <code>DataRow</code> is in this state immediately after it has been created, but before it is added to a collection. It is also in this state if it has been removed from a collection. |
| Modified | The row has been modified, and <code>AcceptChanges()</code> has not been called. |
| Unchanged | The row has not changed since <code>AcceptChanges()</code> was last called. |

When you manipulate the rows of a given `DataTable` programmatically, the `RowState` property is set automatically. For example, add a new method to your `Program` class, which operates on a local `DataRow` object, printing out its row state along the way, like so:

```

private static void ManipulateDataRowState()
{
    // Create a temp DataTable for testing.
    var temp = new DataTable("Temp");
    temp.Columns.Add(new DataColumn("TempColumn", typeof(int)));
}

```

```

// RowState = Detached.
var row = temp.NewRow();
WriteLine($"After calling NewRow(): {row.RowState}");

// RowState = Added.
temp.Rows.Add(row);
WriteLine($"After calling Rows.Add(): {row.RowState}");

// RowState = Added.
row["TempColumn"] = 10;
WriteLine($"After first assignment: {row.RowState}");

// RowState = Unchanged.
temp.AcceptChanges();
WriteLine($"After calling AcceptChanges: {row.RowState}");

// RowState = Modified.
row["TempColumn"] = 11;
WriteLine($"After first assignment: {row.RowState}");

// RowState = Deleted.
temp.Rows[0].Delete();
WriteLine($"After calling Delete: {row.RowState}");
}

```

■ **Note** Remember to add `using static System.Console;` to the top of your code file for this example (and all other examples where you are using the console).

The ADO.NET `DataRow` is smart enough to remember its current state of affairs. Given this, the owning `DataTable` is able to identify which rows have been added, updated, or deleted. This is a key feature of the `DataSet` because when it comes time to send updated information to the data store, only the modified data is submitted.

Understanding the `DataRowVersion` Property

Beyond maintaining the current state of a row with the `RowState` property, a `DataRow` object maintains three possible versions of the data it contains using the `DataRowVersion` property. When a `DataRow` object is first constructed, it contains only a single copy of data, represented as the current version. However, as you programmatically manipulate a `DataRow` object (using various method calls), additional versions of the data spring to life. Specifically, you can set the `DataRowVersion` to any value of the related `DataRowVersion` enumeration (see Table 22-6).

Table 22-6. *Values of the DataRowVersion Enumeration*

| Value | Meaning in Life |
|----------|--|
| Current | This represents the current value of a row, even after changes have been made. |
| Default | This is the default version of DataRowState. For a DataRowState value of Added, Modified, or Deleted, the default version is Current. For a DataRowState value of Detached, the version is Proposed. |
| Original | This represents the value first inserted into a DataRow or the value the last time AcceptChanges() was called. |
| Proposed | This is the value of a row currently being edited because of a call to BeginEdit(). |

As suggested in Table 22-6, the value of the `DataRowVersion` property is dependent on the value of the `DataRowState` property in many cases. As mentioned previously, the `DataRowVersion` property will be changed behind the scenes when you invoke various methods on the `DataRow` (or, in some cases, the `DataTable`) object. Here is a breakdown of the methods that can affect the value of a row's `DataRowVersion` property:

- If you call the `DataRow.BeginEdit()` method and change the row's value, the `Current` and `Proposed` values become available.
- If you call the `DataRow.CancelEdit()` method, the `Proposed` value is deleted.
- After you call `DataRow.EndEdit()`, the `Proposed` value becomes the `Current` value.
- After you call the `DataRow.AcceptChanges()` method, the `Original` value becomes identical to the `Current` value. The same transformation occurs when you call `DataTable.AcceptChanges()`.
- After you call `DataRow.RejectChanges()`, the `Proposed` value is discarded, and the version becomes `Current`.

Yes, this is a bit convoluted, not least because a `DataRow` might or might not have all versions at any given time (you'll receive runtime exceptions if you attempt to obtain a row version that is not currently tracked). Regardless of the complexity, given that the `DataRow` maintains three copies of data, it becomes simple to build a front end that allows an end user to alter values, change his or her mind and roll back values, or commit values permanently. You'll see various examples of manipulating these methods over the remainder of this chapter.

Working with DataTables

The `DataTable` type defines many members, many of which are identical in name and functionality to those of the `DataSet`. Table 22-7 describes some core members of the `DataTable` type beyond `Rows` and `Columns`.

Table 22-7. Key Members of the DataTable Type

| Member | Meaning in Life |
|-----------------|--|
| CaseSensitive | Indicates whether string comparisons within the table are case sensitive. The default value is false. |
| ChildRelations | Returns the collection of child relations for this DataTable (if any). |
| Constraints | Gets the collection of constraints maintained by the table. |
| Copy() | A method that copies the schema and data of a given DataTable into a new instance. |
| DataSet | Gets the DataSet that contains this table (if any). |
| DefaultView | Gets a customized view of the table that might include a filtered view or a cursor position. |
| ParentRelations | Gets the collection of parent relations for this DataTable. |
| PrimaryKey | Gets or sets an array of columns that function as primary keys for the data table. |
| TableName | Gets or sets the name of the table. This same property might also be specified as a constructor parameter. |

To continue with the current example, you can set the `PrimaryKey` property of the `DataTable` to the `carIDColumn` `DataColumn` object. Be aware that the `PrimaryKey` property is assigned a collection of `DataColumn` objects to account for a multicolumned key. In this case, however, you need to specify only the `CarID` column (being the first ordinal position in the table), like so:

```
static void FillDataSet(DataSet ds)
{
    ...
    // Mark the primary key of this table.
    inventoryTable.PrimaryKey = new [] { inventoryTable.Columns[0] };
}
```

Inserting DataTables into DataSets

At this point, your `DataTable` object is complete. The final step is to insert the `DataTable` into the `carsInventoryDS` `DataSet` object using the `Tables` collection, like this:

```
static void FillDataSet(DataSet ds)
{
    ...
    // Finally, add our table to the DataSet.
    ds.Tables.Add(inventoryTable);
}
```

Now update your `Main()` method to call `FillDataSet()`, passing in your local `DataSet` object as an argument. Next, pass the same object into a new (yet to be written) helper method named `PrintDataSet()`, as follows:

```
static void Main(string[] args)
{
    WriteLine("***** Fun with DataSets *****\n");
    ...
    FillDataSet(carsInventoryDS);
    PrintDataSet(carsInventoryDS);
    ReadLine();
}
```

Obtaining Data in a DataSet

The `PrintDataSet()` method simply iterates over the `DataSet` metadata (using the `ExtendedProperties` collection) and each `DataTable` in the `DataSet`, printing out the column names and row values using the type indexers. Add a `using` for `System.Collections` to the top of the file for the `DictionaryEntry` type.

```
static void PrintDataSet(DataSet ds)
{
    // Print out the DataSet name and any extended properties.
    WriteLine($"DataSet is named: {ds.DataSetName}");
    foreach (DictionaryEntry de in ds.ExtendedProperties)
    {
        WriteLine($"Key = {de.Key}, Value = {de.Value}");
    }
    WriteLine();
    // Print out each table using rows and columns.
    foreach (DataTable dt in ds.Tables)
    {
        WriteLine($"=> {dt.TableName} Table:");

        // Print out the column names.
        for (var curCol = 0; curCol < dt.Columns.Count; curCol++)
        {
            Write($"{dt.Columns[curCol].ColumnName}\t");
        }
        WriteLine("\n-----");

        // Print the DataTable.
        for (var curRow = 0; curRow < dt.Rows.Count; curRow++)
        {
            for (var curCol = 0; curCol < dt.Columns.Count; curCol++)
            {
                Write($"{dt.Rows[curRow][curCol]}\t");
            }
            WriteLine();
        }
    }
}
```

If you run your program now, you'll see the following output (your timestamp and GUID value will differ, of course):

```
***** Fun with DataSets *****

DataSet is named: Car Inventory
Key = TimeStamp, Value = 7/24/2015 6:41:09 AM
Key = DataSetID, Value = 11c533ed-d1aa-4c82-96d4-b0f88893ab21
Key = Company, Value = Mikko's Hot Tub Super Store

=> Inventory Table:
CarID   Make   Color  PetName
-----
1       BMW    Black  Hamlet
2       Saab   Red    Sea Breeze
```

Processing DataTable Data Using DataTableReader Objects

Given your work in Chapter 21, you should notice that the manner in which you process data using the connected layer (e.g., data reader objects) and the disconnected layer (e.g., DataSet objects) is quite different. Working with a data reader typically involves establishing a `while` loop, calling the `Read()` method, and using an indexer to pluck out the name-value pairs. On the other hand, DataSet processing typically involves a series of iteration constructs to drill into the data within the tables, rows, and columns (remember that DataReader requires an open database connection so that it can read the data from the actual database).

DataTables support a method named `CreateDataReader()`. This method allows you to obtain the data within a DataTable using a data reader-like navigation scheme (the data reader will now read data from the in-memory DataTable, not from the actual database, so there's no database connection involved here). The major benefit of this approach is that you now use a single model to process data, regardless of which layer of ADO.NET you use to obtain it. Assume you have authored a new method in your Program class named `PrintTable()`, as follows:

```
static void PrintTable(DataTable dt)
{
    // Get the DataTableReader type.
    DataTableReader dtReader = dt.CreateDataReader();

    // The DataTableReader works just like the DataReader.
    while (dtReader.Read())
    {
        for (var i = 0; i < dtReader.FieldCount; i++)
        {
            Write($"{dtReader.GetValue(i).ToString().Trim()}\t");
        }
        WriteLine();
    }
    dtReader.Close();
}
```

Notice that the `DataTableReader` works identically to the data reader object of your data provider. A `DataTableReader` can be an ideal choice when you need to pump out the data within a `DataTable` quickly, without needing to traverse the internal row and column collections. Now assume you have updated the previous `PrintDataSet()` method to invoke `PrintTable()`, rather than drilling into the `Rows` and `Columns` collections.

```
static void PrintDataSet(DataSet ds)
{
    // Print out any name and extended properties.
    WriteLine($"DataSet is named: {ds.DataSetName}");
    foreach (DictionaryEntry de in ds.ExtendedProperties)
    {
        WriteLine($"Key = {de.Key}, Value = {de.Value}");
    }
    WriteLine();

    //Print out each table using data reader
    foreach (DataTable dt in ds.Tables)
    {
        WriteLine($"=> {dt.TableName} Table:");

        // Print out the column names.
        for (int curCol = 0; curCol < dt.Columns.Count; curCol++)
        {
            Write($"{dt.Columns[curCol].ColumnName.Trim()}\t");
        }
        WriteLine("\n-----");

        // Call our new helper method.
        PrintTable(dt);
    }
}
```

When you run the application, the output is identical to that shown previously. The only difference is how you access the `DataTable`'s contents internally.

Serializing DataTable/DataSet Objects As XML

`DataSets` and `DataTables` both support the `WriteXml()` and `ReadXml()` methods. `WriteXml()` allows you to persist an object's content to a local file (as well as into any `System.IO.Stream`-derived type) as an XML document. `ReadXml()` allows you to hydrate the state of a `DataSet` (or `DataTable`) from a given XML document. In addition, `DataSets` and `DataTables` both support `WriteXmlSchema()` and `ReadXmlSchema()` for saving or loading an `*.xsd` file.

To test this for yourself, update your `Main()` method to call the following helper function (notice that you pass a `DataSet` as the sole parameter):

```
static void SaveAndLoadAsXml(DataSet carsInventoryDS)
{
    // Save this DataSet as XML.
    carsInventoryDS.WriteXml("carsDataSet.xml");
    carsInventoryDS.WriteXmlSchema("carsDataSet.xsd");

    // Clear out DataSet.
    carsInventoryDS.Clear();

    // Load DataSet from XML file.
    carsInventoryDS.ReadXml("carsDataSet.xml");
}
```

If you open the `carsDataSet.xml` file (which you will find under the `\bin\Debug` folder of your project), you will find that each column in the table has been encoded as an XML element.

```
<?xml version="1.0" standalone="yes"?>
<Car_x0020_Inventory>
  <Inventory>
    <CarID>1</CarID>
    <Make>BMW</Make>
    <Color>Black</Color>
    <PetName>Hamlet</PetName>
  </Inventory>
  <Inventory>
    <CarID>2</CarID>
    <Make>Saab</Make>
    <Color>Red</Color>
    <PetName>Sea Breeze</PetName>
  </Inventory>
</Car_x0020_Inventory>
```

If you were to double-click the generated `*.xsd` file (also found in your `\bin\Debug` folder) within Visual Studio, you will open the IDE's XML schema editor (see Figure 22-3).

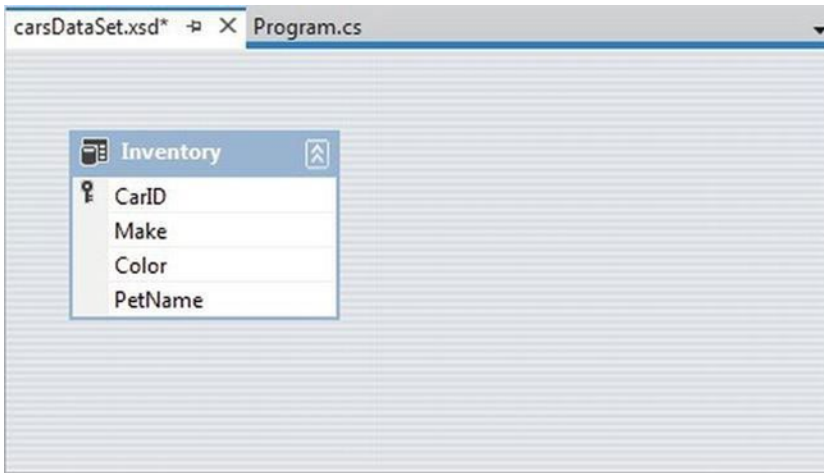

Figure 22-3. The XSD editor of Visual Studio

■ **Note** Chapter 24 will introduce you to the LINQ to XML API, which is the preferred manner for manipulating XML data in the .NET platform.

Serializing DataTable/DataSet Objects in a Binary Format

It is also possible to persist the contents of a DataSet (or an individual DataTable) as a compact binary format. This can be especially helpful when a DataSet object needs to be passed across a machine boundary (in the case of a distributed application). One drawback of XML data representation is that its descriptive nature can result in a good deal of overhead.

To persist DataTables or DataSets in a binary format, set the `RemotingFormat` property to `SerializationFormat.Binary`. At this point, you can use the `BinaryFormatter` type (see Chapter 20) as expected. Consider the following final method of the `SimpleDataSet` project (don't forget to import the `System.IO` and `System.Runtime.Serialization.Formatters.Binary` namespaces):

```
static void SaveAndLoadAsBinary(DataSet carsInventoryDS)
{
    // Set binary serialization flag.
    carsInventoryDS.RemotingFormat = SerializationFormat.Binary;

    // Save this DataSet as binary.
    var fs = new FileStream("BinaryCars.bin", FileMode.Create);
    var bFormat = new BinaryFormatter();
    bFormat.Serialize(fs, carsInventoryDS);
    fs.Close();

    // Clear out DataSet.
    carsInventoryDS.Clear();
}
```

```
// Load DataSet from binary file.
fs = new FileStream("BinaryCars.bin", FileMode.Open);
var data = (DataSet)bFormat.Deserialize(fs);
}
```

If you call this method from `Main()`, you can find the `*.bin` file in your `bin\Debug` folder. Figure 22-4 shows the contents of the `BinaryCars.bin` file.

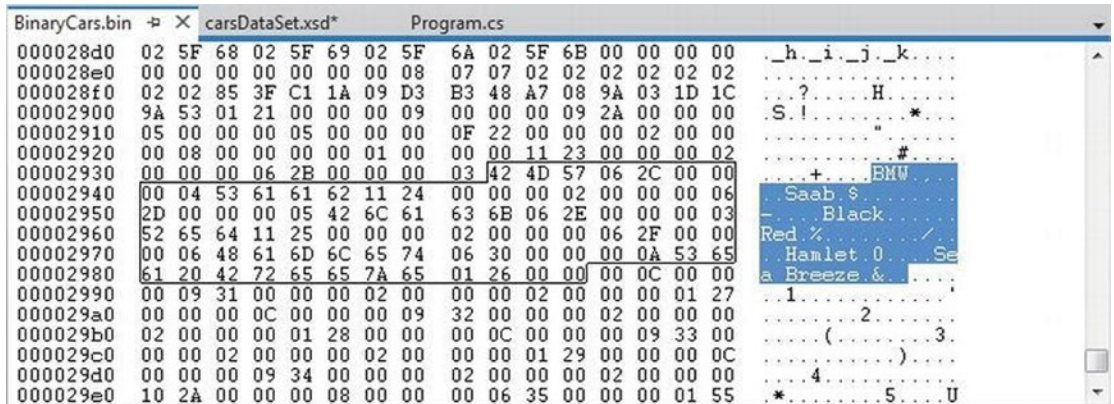

Figure 22-4. A `DataSet` saved to a binary format

■ **Source Code** You can find the `SimpleDataSet` application in the Chapter 22 subdirectory.

Binding `DataTable` Objects to Windows Forms GUIs

So far, you have examined how to create, hydrate, and iterate over the contents of a `DataSet` object manually using the inherit object model of ADO.NET. While understanding how to do so is quite important, the .NET platform ships with numerous APIs that have the ability to *bind* data to user interface elements automatically.

For example, the original GUI toolkit of .NET, Windows Forms, supplies a control named `DataGridView` that includes the built-in ability to display the contents of a `DataSet` or `DataTable` object using only a few lines of code. ASP.NET (.NET's web development API) and the Windows Presentation Foundation API also support the notion of data binding. You will learn to bind data to WPF and ASP.NET GUI elements later in this book; however, in this chapter, you will use Windows Forms because it is a fairly simple and straightforward programming model.

■ **Note** The next example assumes you have some experience using Windows Forms to build graphical user interfaces. If this is not the case, you might want to open the solution and follow along or return to this section after you have read Appendix A.

Your next task is to build a Windows Forms application that will display the contents of a `DataTable` object within its user interface. Along the way, you will also examine how to filter and change table data. You will also learn about the role of the `DataView` object.

Begin by creating a new Windows Forms project workspace named `WindowsFormsDataBinding`. Rename your initial `Form1.cs` file to the more fitting `MainForm.cs` using the Solution Explorer. Change the text of the form to `Windows Forms Data Binding` using the Properties window. Next, use the Visual Studio Toolbox to drag a `DataGridView` control located in the `Data` tab (renamed to `carInventoryGridView` using the `(Name)` property of the Properties window) onto the designer surface. You might notice that when you first add the `DataGridView` on the designer, you activate a context menu that allows you to connect to a physical data source. For the time being, ignore this aspect of the designer because you will be binding your `DataTable` object programmatically. Finally, add a descriptive `Label` to your designer for information purposes. Figure 22-5 shows one possible look and feel.

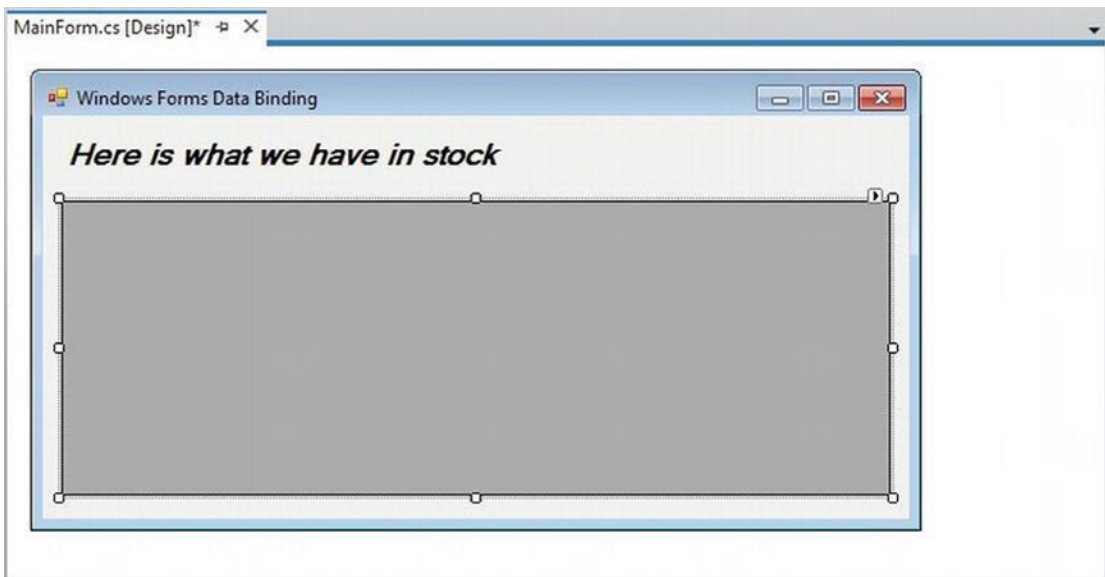

Figure 22-5. The initial GUI of your Windows Forms application

Hydrating a `DataTable` from a Generic `List<T>`

Similar to the previous `SimpleDataSet` example, the `WindowsFormsDataBinding` application will construct a `DataTable` that contains a set of `DataColumns` representing various columns and rows of data. This time, however, you will fill the rows using a generic `List<T>` member variable. First, insert a new `C#` class into your project (named `Car`), which you define as follows:

```
public class Car
{
    public int Id { get; set; }
    public string PetName { get; set; }
    public string Make { get; set; }
    public string Color { get; set; }
}
```

Within the default constructor of your main form, populate a `List<T>` member variable (named `listCars`) with a set of new `Car` objects, like so:

```
public partial class MainForm : Form
{
    // A collection of Car objects.
    List<Car> listCars = null;

    public MainForm()
    {
        InitializeComponent();

        // Fill the list with some cars.
        listCars = new List<Car>
        {
            new Car { Id = 1, PetName = "Chucky", Make = "BMW", Color = "Green" },
            new Car { Id = 2, PetName = "Tiny", Make = "Yugo", Color = "White" },},
            new Car { Id = 3, PetName = "Ami", Make = "Jeep", Color = "Tan" },
            new Car { Id = 4, PetName = "Pain Inducer", Make = "Caravan", Color = "Pink" },
            new Car { Id = 5, PetName = "Fred", Make = "BMW", Color = "Green" },
            new Car { Id = 6, PetName = "Sidd", Make = "BMW", Color = "Black" },
            new Car { Id = 7, PetName = "Mel", Make = "Firebird", Color = "Red" },
            new Car { Id = 8, PetName = "Sarah", Make = "Colt", Color = "Black" },
        };
    }
}
```

Next, add a new member variable named `inventoryTable` of type `DataTable` to your `MainForm` class type, like so:

```
public partial class MainForm : Form
{
    // A collection of Car objects.
    List<Car> listCars = null;

    // Inventory information.
    DataTable inventoryTable = new DataTable();
    ...
}
```

Now add a new helper function to your class named `CreateDataTable()` and call this method within the default constructor of the `MainForm` class.

```
void CreateDataTable()
{
    // Create table schema.
    var carIDColumn = new DataColumn("Id", typeof(int));
    var carMakeColumn = new DataColumn("Make", typeof(string));
    var carColorColumn = new DataColumn("Color", typeof(string));
    var carPetNameColumn = new DataColumn("PetName", typeof(string))
    { Caption = "Pet Name"};
    inventoryTable.Columns.AddRange(
        new[] { carIDColumn, carMakeColumn, carColorColumn, carPetNameColumn });
}
```

```

// Iterate over the array list to make rows.
foreach (var c in listCars)
{
    var newRow = inventoryTable.NewRow();
    newRow["Id"] = c.Id;
    newRow["Make"] = c.Make;
    newRow["Color"] = c.Color;
    newRow["PetName"] = c.PetName;
    inventoryTable.Rows.Add(newRow);
}

// Bind the DataTable to the carInventoryGridView.
carInventoryGridView.DataSource = inventoryTable;
}

```

The method implementation begins by creating the schema of the `DataTable` by creating four `DataColumn` objects (for the sake of simplicity, you don't need to bother auto-incrementing the ID field or set it as a primary key). After you do this, you can add them to the column collection of the `DataTable` member variable. You map the row data from your `List<Car>` collection into the `DataTable` using a `foreach` iteration construct and the native ADO.NET object model.

However, notice that the final code statement within the `CreateDataTable()` method assigns the `inventoryTable` to the `DataSource` property of the `DataGridView` object. This single property is all you need to set to bind a `DataTable` to a Windows Forms `DataGridView` object. Under the hood, this GUI control reads the row and column collections internally, much like what happens with the `PrintDataSet()` method of the `SimpleDataSet` example. At this point, you should be able to run your application and see the `DataTable` within the `DataGridView` control, as shown in Figure 22-6.

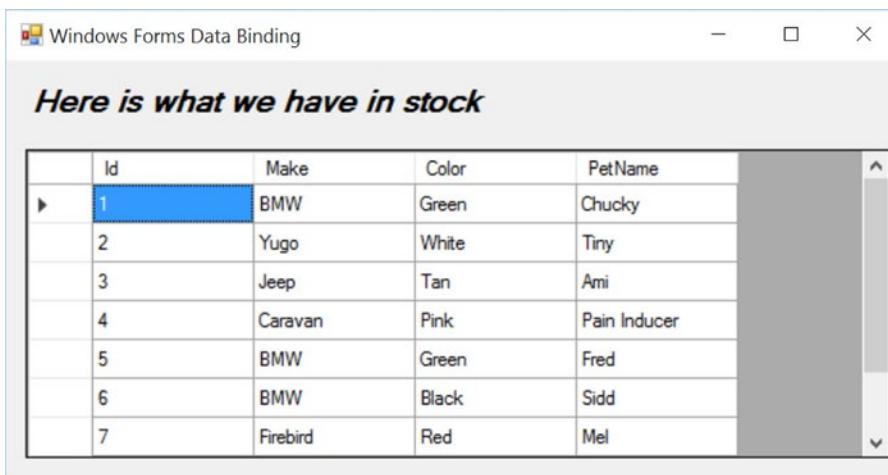

Figure 22-6. Binding a `DataTable` to a Windows Forms `DataGridView`

Deleting Rows from a DataTable

Now, assume you would like to update your graphical interface to allow the user to delete a row from the in-memory `DataTable` that is bound to the `DataGridView`. One approach is to call the `Delete()` method of the `DataRow` object that represents the row to terminate. In this case, you specify the index (or `DataRow` object) representing the row to remove. To allow the user to specify which row to delete, add a `TextBox` (named `txtCarToRemove`) and a `Button` control (named `btnRemoveCar`) to the current designer. Figure 22-7 shows one possible UI update (note this example wraps the two controls in a `GroupBox` control, illustrating how they are related).

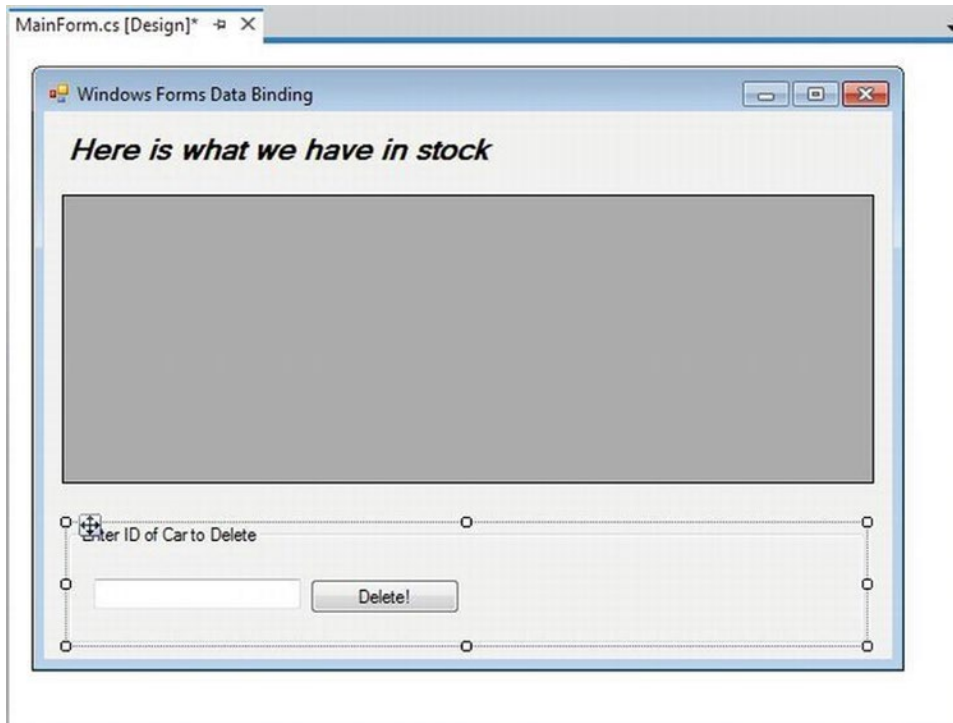

Figure 22-7. Updating the UI to enable removal of rows from the underlying `DataTable`

The following logic behind the new `Button`'s `Click` event handler removes the user-specified row, based on the ID of a car, from your in-memory `DataTable`. The `Select()` method of the `DataTable` class allows you to specify a search criteria, which is modeled after normal SQL syntax. The return value is an array of `DataRow` objects that matches the search criteria.

```
// Remove this row from the DataRowCollection.
private void btnRemoveCar_Click (object sender, EventArgs e)
{
    try
    {
        // Find the correct row to delete.
        DataRow[] rowToDelete = inventoryTable.Select($"Id={int.Parse(txtCarToRemove.Text)}");
```

```

// Delete it!
rowToDelete[0].Delete();
inventoryTable.AcceptChanges();
}
catch (Exception ex)
{
    MessageBox.Show(ex.Message);
}
}

```

You should now be able to run your application and specify a car ID to delete from the `DataTable`. As you remove `DataRow` objects from the `DataTable`, you will notice that the grid's UI is updated immediately; this occurs because it is bound to the state of the `DataTable` object.

Selecting Rows Based on Filter Criteria

Many data-centric applications require the need to view a small subset of a `DataTable`'s data, as specified by some sort of filtering criteria. For example, assume you want to see only a certain make of automobile from the in-memory `DataTable` (e.g., only BMWs). You've already seen how the `Select()` method of the `DataTable` class allows you to find a row to delete; however, you can also use this method to grab a subset of records for display purposes.

To see this in action, update your UI again, this time allowing users to specify a string that represents the make of the automobile they want to see (see Figure 22-8) using a new `TextBox` (named `txtMakeToView`) and a new `Button` (named `btnDisplayMakes`).

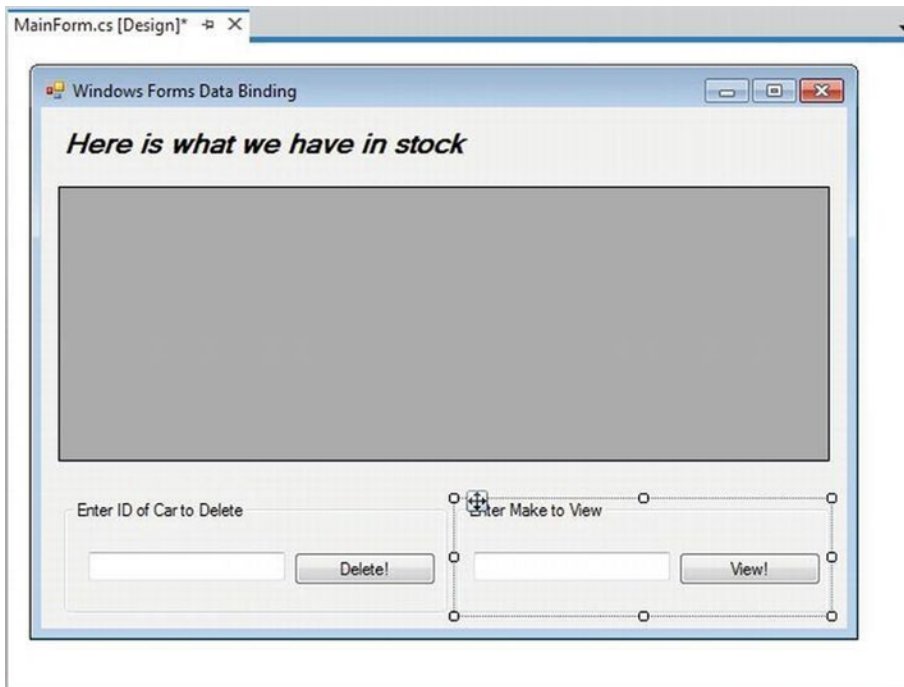

Figure 22-8. Updating the UI to enable row filtering

The `Select()` method has been overloaded a number of times to provide different selection semantics. At its most basic level, the parameter sent to `Select()` is a string that contains some conditional operation. To begin, observe the following logic for the Click event handler of your new button:

```
private void btnDisplayMakes_Click(object sender, EventArgs e)
{
    // Build a filter based on user input.
    string filterStr = $"Make='{txtMakeToView.Text}'";

    // Find all rows matching the filter.
    DataRow[] makes = inventoryTable.Select(filterStr);

    // Show what we got!
    if (makes.Length == 0)
        MessageBox.Show("Sorry, no cars...", "Selection error!");
    else
    {
        string strMake = null;
        for (var i = 0; i < makes.Length; i++)
        {
            strMake += makes[i]["PetName"] + "\n";
        }
        // Now show all matches in a message box.
        MessageBox.Show(strMake, $"We have {txtMakeToView.Text}s named:");
    }
}
```

Here, you begin by building a simple filter based on the value in the associated `TextBox`. If you specify `BMW` in the filter text box, it will create a filter equivalent to `Make = 'BMW'`. When you send this filter to the `Select()` method, you get back an array of `DataRow` types that represent each row that matches the filter (see Figure 22-9).

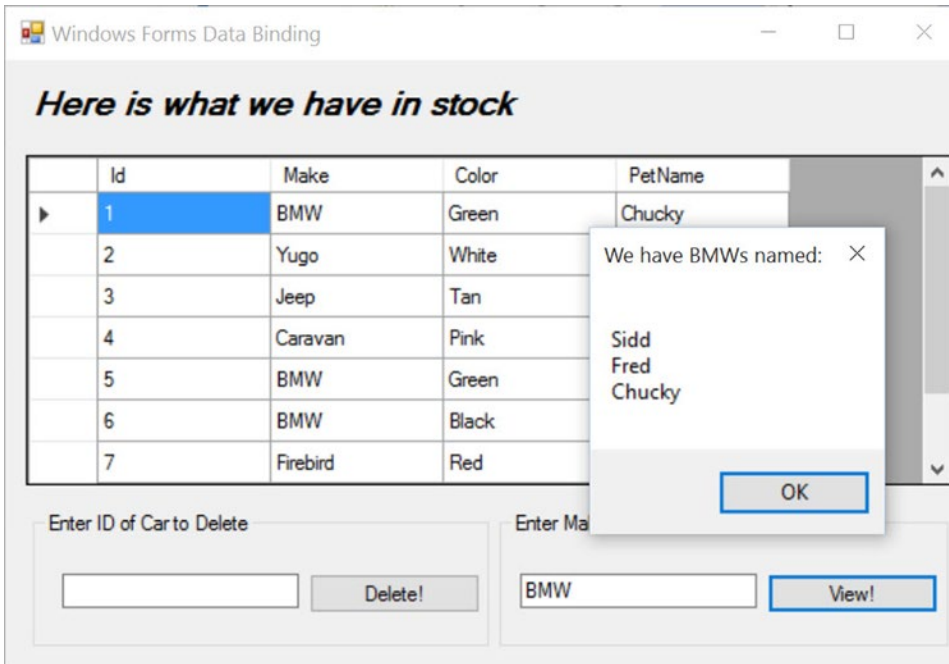

Figure 22-9. *Displaying filtered data*

Again, the filtering logic is based on standard SQL syntax. For example, assume you want to obtain the results of the previous `Select()` invocation alphabetically, based on the pet name. In terms of SQL, this translates into a sort based on the `PetName` column. Fortunately, the `Select()` method has been overloaded to send in a sort criterion.

```
// Sort by PetName.
makes = inventoryTable.Select(filterStr, "PetName");
```

Call `Select()`, as shown here, if you want the results in descending order:

```
// Return results in descending order.
makes = inventoryTable.Select(filterStr, "PetName DESC");
```

In general, the sort string contains the column name, followed by `ASC` (ascending, which is the default) or `DESC` (descending). If necessary, you can separate multiple columns by commas. Finally, understand that a filter string can be composed of any number of relational operators. For example, assume you want to find all cars with an ID greater than 5. This helper function lets you accomplish that:

```
private void ShowCarsWithIdGreaterThanFive()
{
    // Now show the pet names of all cars with ID greater than 5.
    DataRow[] properIDs;
    string newFilterStr = "ID > 5";
    properIDs = inventoryTable.Select(newFilterStr);
    string strIDs = null;
}
```

```

for(int i = 0; i < properIDs.Length; i++)
{
    DataRow temp = properIDs[i];
    strIDs += $"{temp["PetName"]} is ID {temp["ID"]}\n";
}
MessageBox.Show(strIDs, "Pet names of cars where ID > 5");
}

```

Updating Rows Within a DataTable

The final aspect of the `DataTable` you should be aware of is the process of updating an existing row with new values. One approach is to first obtain the row (or rows) that matches a given filter criterion using the `Select()` method. Once you obtain the `DataRow` (or `DataRows`) in question, modify them accordingly. For example, assume you have a new `Button` on your form named `btnChangeMakes` that (when clicked) searches the `DataTable` for all rows where `Make` is equal to `BMW`. Once you identify these items, you change the `Make` from `BMW` to `Yugo`, as so:

```

// Find the rows you want to edit with a filter.
private void btnChangeMakes_Click(object sender, EventArgs e)
{
    // Make sure user has not lost his or her mind.
    if (DialogResult.Yes !=
        MessageBox.Show("Are you sure?? BMWs are much nicer than Yugos!",
            "Please Confirm!", MessageBoxButtons.YesNo)) return;
    // Build a filter.
    string filterStr = "Make='BMW'";

    // Find all rows matching the filter.
    DataRow[] makes = inventoryTable.Select(filterStr);

    // Change all Beemers to Yugos!
    for (int i = 0; i < makes.Length; i++)
    {
        makes[i]["Make"] = "Yugo";
    }
}

```

Working with the DataView Type

A *view object* is an alternative representation of a table (or set of tables). For example, you can use Microsoft SQL Server to create a view for your `Inventory` table that returns a new table containing automobiles only of a given color. In ADO.NET, the `DataView` type allows you to extract a subset of data programmatically from the `DataTable` into a stand-alone object.

One great advantage of holding multiple views of the same table is that you can bind these views to various GUI widgets (such as the `DataGridView`). For example, one `DataGridView` might be bound to a `DataView` showing all automobiles in the `Inventory`, while another might be configured to display only green automobiles.

To see this in action, update the current UI with an additional `DataGridView` type named `dataGridYugosView` and a descriptive `Label`. Next, define a member variable named `yugosOnlyView` of type `DataView`.

```
public partial class MainForm : Form
{
    // View of the DataTable.
    DataView yugosOnlyView;
    ...
}
```

Now create a new helper function named `CreateDataView()` and call this method within the form's default constructor immediately after the `DataTable` has been fully constructed, as shown here:

```
public MainForm()
{
    ...
    // Make a data table.
    CreateDataTable();

    // Make a view.
    CreateDataView();
}
```

Here is the implementation of this new helper function. Notice that the constructor of the `DataView` has been passed the `DataTable` that you will use to build the custom set of data rows.

```
private void CreateDataView()()
{
    // Set the table that is used to construct this view.
    yugosOnlyView = new DataView(inventoryTable);

    // Now configure the views using a filter.
    yugosOnlyView.RowFilter = "Make = 'Yugo'";

    // Bind to the new grid.
    dataGridYugosView.DataSource = yugosOnlyView;
}
```

As you can see, the `DataView` class supports a property named `RowFilter`, which contains the string representing the filtering criteria used to extract matching rows. After you establish your view, set the grid's `DataSource` property accordingly. Figure 22-10 shows the completed Windows Forms data-binding application in action.

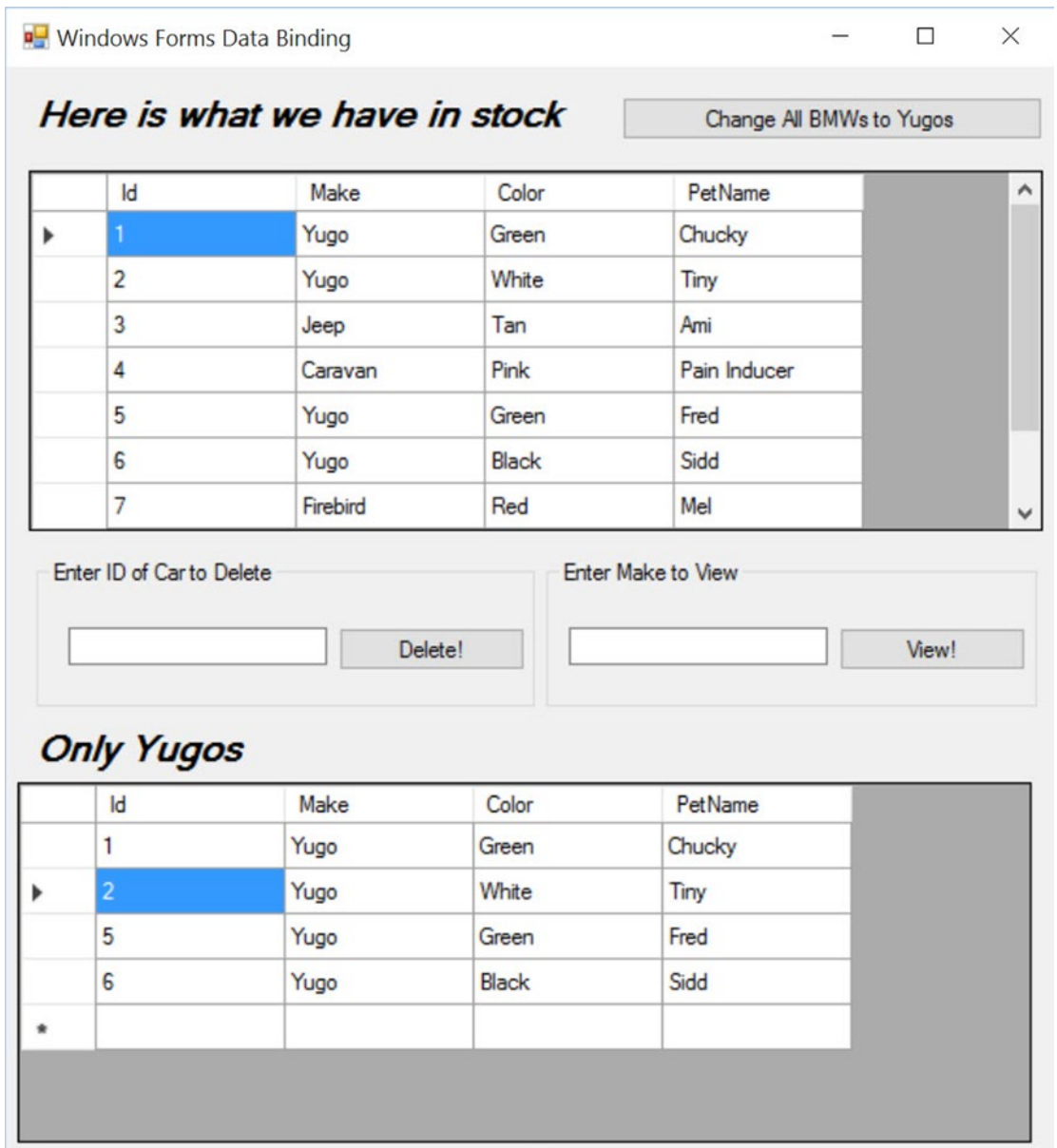

Figure 22-10. Displaying a unique view of your data

■ **Source Code** You can find the WindowsFormsDataBinding project in the Chapter 22 subdirectory.

Working with Data Adapters

Now that you understand the ins and outs of manipulating ADO.NET DataSets manually, it's time to turn your attention to the topic of *data adapter objects*. A data adapter is a class used to fill a DataSet with DataTable objects; this class can also send modified DataTables back to the database for processing. Table 22-8 documents the core members of the DbDataAdapter base class, the common parent to every data adapter object (e.g., SqlDataAdapter and OdbcDataAdapter).

Table 22-8. Core Members of the DbDataAdapter Class

| Members | Meaning in Life |
|--|---|
| Fill() | Executes a SQL SELECT command (as specified by the SelectCommand property) to query the database for data and loads the data into a DataTable. |
| SelectCommand InsertCommand UpdateCommand DeleteCommand | Establishes the SQL commands that you will issue to the data store when the Fill() and Update() methods are called. |
| Update() | Executes SQL INSERT, UPDATE, and DELETE commands (as specified by the InsertCommand, UpdateCommand, and DeleteCommand properties) to persist DataTable changes to the database. |

Notice that a data adapter defines four properties: SelectCommand, InsertCommand, UpdateCommand, and DeleteCommand. When you create the data adapter object for your particular data provider (e.g., SqlDataAdapter), you can pass in a string that represents the command text used by the SelectCommand's command object.

Assuming each of the four command objects has been properly configured, you can then call the Fill() method to obtain a DataSet (or a single DataTable, if you so choose). To do so, you have the data adapter execute the SQL SELECT statement specified by the SelectCommand property.

Similarly, if you want to persist a modified DataSet (or DataTable) object back to the database, you can call the Update() method, which will use any of the remaining command objects, based on the state of each row in the DataTable (you'll learn more about this in a bit).

One of the strangest aspects of working with a data adapter object is that you are never required to open or close a connection to the database. Rather, the underlying connection to the database is managed on your behalf. However, you will still need to supply the data adapter with a valid connection object or a connection string (which you will use to build a connection object internally) to inform the data adapter exactly which database you want to communicate with.

■ **Note** A data adapter is agnostic by nature. You can plug in different connection objects and command objects on the fly and fetch data from a diverse variety of databases. For example, a single DataSet could contain table data obtained from SQL Server, Oracle, and MySQL database providers.

A Simple Data Adapter Example

The next step is to add new functionality to the data access library assembly (AutoLotDAL.dll) you created in Chapter 21. You will begin by creating a simple example that fills a DataSet with a single table using an ADO.NET data adapter object.

Create a new Console Application project named `FillDataSetUsingSqlDataAdapter` and import the `System.Data`, `System.Data.SqlClient`, and `System.Collections` namespaces into your initial C# code file. Now update your `Main()` method as follows (you might need to change the connection string based on how you created the `AutoLot` database in Chapter 21):

```
static void Main(string[] args)
{
    WriteLine("***** Fun with Data Adapters *****\n");

    // Hard-coded connection string.
    string connectionString = "Integrated Security = SSPI;Initial Catalog=AutoLot;" +
        @"Data Source=(local)\SQLEXPRESS2014";

    // Caller creates the DataSet object.
    DataSet ds = new DataSet("AutoLot");

    // Inform adapter of the Select command text and connection.
    SqlDataAdapter adapter =
        new SqlDataAdapter("Select * From Inventory", connectionString);

    // Fill our DataSet with a new table, named Inventory.
    adapter.Fill(ds, "Inventory");

    // Display contents of DataSet.
    PrintDataSet(ds);
    ReadLine();
}
```

Notice that you construct the data adapter by specifying a string literal that will map to the SQL `SELECT` statement. You will use this value to build a command object internally, which you can obtain later using the `SelectCommand` property.

Next, notice that it is the job of the caller to create an instance of the `DataSet` type, which is passed into the `Fill()` method. Optionally, you can pass the `Fill()` method as a second argument a string name that you use to set the `TableName` property of the new `DataTable` (if you do not specify a table name, the data adapter will simply name the table, `Table`). In most cases, the name you assign a `DataTable` will be identical to the name of the physical table in the relational database; however, this is not required.

■ **Note** The `Fill()` method returns an integer that represents the number of rows returned by the SQL query.

Finally, notice that you do not explicitly open or close the connection to the database anywhere in the `Main()` method. You preprogram the `Fill()` method of a given data adapter to open and then close the underlying connection before returning from the `Fill()` method. Therefore, when you pass the `DataSet` to the `PrintDataSet()` method (implemented earlier in this chapter and included here for your reference), you are operating on a local copy of disconnected data, incurring no round-trips to fetch the data.

```

static void PrintDataSet(DataSet ds)
{
    // Print out any name and extended properties.
    WriteLine($"DataSet is named: {ds.DataSetName}");
    foreach (DictionaryEntry de in ds.ExtendedProperties)
    {
        WriteLine($"Key = {de.Key}, Value = {de.Value}");
    }
    WriteLine();
    foreach (DataTable dt in ds.Tables)
    {
        WriteLine($"=> {dt.TableName} Table:");
        // Print out the column names.
        for (int curCol = 0; curCol < dt.Columns.Count; curCol++)
        {
            Write(dt.Columns[curCol].ColumnName + "\t");
        }
        WriteLine("\n-----");
        // Print the DataTable.
        for (int curRow = 0; curRow < dt.Rows.Count; curRow++)
        {
            for (int curCol = 0; curCol < dt.Columns.Count; curCol++)
            {
                Write(dt.Rows[curRow][curCol].ToString().Trim() + "\t");
            }
            WriteLine();
        }
    }
}

```

Mapping Database Names to Friendly Names

As mentioned previously, database administrators tend to create table and column names that are less than friendly to end users (e.g., `au_id`, `au_fname`, or `au_lname`). The good news is that data adapter objects maintain an internal strongly typed collection (named `DataTableMappingCollection`) of `System.Data.Common.DataTableMapping` objects. You can access this collection using the `TableMappings` property of your data adapter object.

If you so choose, you can manipulate this collection to inform a `DataTable` which *display names* it should use when asked to print its contents. For example, assume you want to map the table name `Inventory` to `Current Inventory` for display purposes. For example, assume you want to display the `CarID`

column name as Car ID (note the extra space) and the PetName column name as Name of Car. To do so, add the following code before calling the Fill() method of your data adapter object (be sure to import the System.Data.Common namespace to gain the definition of the DataTableMapping type):

```
static void Main(string[] args)
{
    ...
    // Now map DB column names to user-friendly names.
    DataTableMapping tableMapping =
        adapter.TableMappings.Add("Inventory", "Current Inventory");
    tableMapping.ColumnMappings.Add("CarId", "Car Id");
    tableMapping.ColumnMappings.Add("PetName", "Name of Car");
    dAdapt.Fill(ds, "Inventory");
    ...
}
```

If you were to run this program again, you would find that the PrintDataSet() method now displays the friendly names of the DataTable and DataRow objects, rather than the names established by the database schema.

```
***** Fun with Data Adapters *****
```

```
DataSet is named: AutoLot
```

```
=> Current Inventory Table:
```

| Car ID | Make | Color | Name of Car |
|--------|------|--------|-------------|
| 1 | VW | Black | Zippy |
| 2 | Ford | Rust | Rusty |
| 3 | Saab | Black | Mel |
| 4 | Yugo | Yellow | Clunker |
| 5 | BMW | Black | Bimmer |
| 6 | BMW | Green | Hank |
| 7 | BMW | Pink | Pinkey |

■ **Source Code** You can find the FillDataSetUsingSqlDataAdapter project in the Chapter 22 subdirectory.

Adding Disconnected Functionality to AutoLotDAL.dll

To illustrate the process of using a data adapter to push changes in a DataTable back to the database for processing, you will now update the AutoLotDAL.dll assembly created in Chapter 21 to include a new namespace (named AutoLotDisconnectedLayer). This namespace contains a new class, InventoryDALDC, that uses a data adapter to interact with a DataTable. You can continue working in your AutoLotDAL project. In the downloaded code for the chapter, the next example is in AutoLotDAL (Version Two).

Defining the Initial Class Type

Add a new folder using the Project ► New Folder menu option. Name this folder `DisconnectedLayer`. In this new folder, insert a new class named `InventoryDALDC` (for **Dis**connected) using the Project ► Add Class menu option. Next, add `public` to the class type in your new code file. Import the `System.Data.SqlClient` namespaces.

Unlike the connection-centric `InventoryDAL` type, this new class doesn't need to provide custom open/close methods because the data adapter handles the details automatically.

Begin by adding a custom constructor that sets a private `string` variable representing the connection string. Also, define a private `SqlDataAdapter` member variable, which you configure by calling a (yet to be created) helper method called `ConfigureAdapter()`, which takes a `SqlDataAdapter` output parameter.

```
namespace AutoLotDAL2.DisconnectedLayer
{
    public class InventoryDALDC
    {
        // Field data.
        private string _connectionString;
        private SqlDataAdapter _adapter = null;

        public InventoryDALDC(string connectionString)
        {
            _connectionString = connectionString;

            // Configure the SqlDataAdapter.
            ConfigureAdapter(out _adapter);
        }
    }
}
```

Configuring the Data Adapter Using the SqlCommandBuilder

When you use a data adapter to modify tables in a `DataSet`, the first order of business is to assign the `UpdateCommand`, `DeleteCommand`, and `InsertCommand` properties with valid command objects (until you do so, these properties return null references).

Configuring the command objects manually for the `InsertCommand`, `UpdateCommand`, and `DeleteCommand` properties can entail a significant amount of code, especially if you use parameterized queries. Recall from Chapter 21 that a parameterized query allows you to build a SQL statement using a set of parameter objects. Thus, if you were to take the long road, you could implement `ConfigureAdapter()` to create three new `SqlCommand` objects manually, each of which contains a set of `SqlParameter` objects. At this point, you could set each object to the `UpdateCommand`, `DeleteCommand`, and `InsertCommand` properties of the adapter.

Visual Studio provides several designer tools to take care of this mundane and tedious code on your behalf. These designers differ a bit based on which API you use (e.g., Windows Forms, WPF, or ASP.NET), but their overall functionality is similar. You'll see examples of using these designers throughout this book, including some Windows Forms designers later in this chapter.

You won't need to author the numerous code statements to configure a data adapter fully at this time; instead, you can take a massive shortcut by implementing `ConfigureAdapter()` like this:

```
private void ConfigureAdapter(out SqlDataAdapter adapter)
{
    // Create the adapter and set up the SelectCommand.
    adapter = new SqlDataAdapter("Select * From Inventory", _connectionString);

    // Obtain the remaining command objects dynamically at runtime
    // using the SqlCommandBuilder.
    var builder = new SqlCommandBuilder(adapter);
}
```

To simplify the construction of data adapter objects, each of the Microsoft-supplied ADO.NET data providers provides a *command builder* type. The `SqlCommandBuilder` automatically generates the values contained within the `SqlDataAdapter`'s `InsertCommand`, `UpdateCommand`, and `DeleteCommand` properties, based on the initial `SelectCommand`. The benefit here is that you do not need to build all the `SqlCommand` and `SqlParameter` types by hand.

Here's an obvious question at this point: how is a command builder able to build these SQL command objects on the fly? The short answer is metadata. When you call the `Update()` method of a data adapter at runtime, the related command builder will read the database's schema data to autogenerate the underlying insert, delete, and update command objects.

Obviously, doing so requires additional round-trips to the remote database; this means it will hurt performance if you use the `SqlCommandBuilder` numerous times in a single application. Here, you minimize the negative effect by calling your `ConfigureAdapter()` method at the time the `InventoryDALDC` object is constructed, retaining the configured `SqlDataAdapter` for use throughout the object's lifetime.

In the previous code snippet, you did not use the command builder object (`SqlCommandBuilder`, in this case) beyond passing in the data adapter object as a constructor parameter. As odd as this might seem, this is all you must do (at a minimum). Under the hood, this type configures the data adapter with the remaining command objects.

While you might love the idea of getting something for nothing, you should understand that command builders come with some critical restrictions. Specifically, a command builder is able only to autogenerate SQL commands for use by a data adapter if all the following conditions are true:

- The SQL `SELECT` command interacts with only a single table (e.g., no joins).
- The single table has been attributed with a primary key.
- The table must have a column or columns representing the primary key that you include in your SQL `SELECT` statement.

Based on the way you constructed your `AutoLot` database, these restrictions pose no problem. However, in a more industrial-strength database, you will need to consider whether this type is at all useful (if not, remember that Visual Studio will autogenerate a good deal of the required code using various database designer tools, as you will see later).

Implementing GetAllInventory()

Now that your data adapter is ready to go, the first method of your new class type will use the `Fill()` method of the `SqlDataAdapter` object to fetch a `DataTable` representing all records in the `Inventory` table of the `AutoLot` database, like so:

```
public DataTable GetAllInventory()
{
    DataTable inv = new DataTable("Inventory");
    _adapter.Fill(inv);
    return inv;
}
```

Implementing UpdateInventory()

The `UpdateInventory()` method is simple, as shown here:

```
public void UpdateInventory(DataTable modifiedTable)
{
    _adapter.Update(modifiedTable);
}
```

Here, the data adapter object examines the `RowState` value of each row of the incoming `DataTable`. Based on this value (e.g., `RowState.Added`, `RowState.Deleted`, or `RowState.Modified`), the correct command object is leveraged behind the scenes.

Setting Your Version Number

Great! At this point, the logic of the second version of your data access library is complete. You are not required to do so, but set the version number of this library to 2.0.0.0, just for good housekeeping. As described in Chapter 14, you can change the version of a .NET assembly by double-clicking the Properties node of your Solution Explorer and then clicking the Assembly Information button located in the Application tab. In the resulting dialog box, set the Major number of the assembly version to the value of 2 (see Chapter 14 for more details). After you do this, recompile your application to update the assembly manifest.

■ **Source Code** You can find the `AutoLotDAL2` project in the Chapter 22 subdirectory.

Testing the Disconnected Functionality

At this point, you can build a front end to test your new `InventoryDALDC` class. Once again, you will use the Windows Forms API to display your data on a graphical user interface. Create a new Windows Forms application named `InventoryDALDisconnectedGUI`, change your initial `Form1.cs` file to `MainForm.cs` using the Solution Explorer, and set the `Text` property of the form to `Simple GUI Front End to the Inventory Table`. After you create the project, set a reference to your updated `AutoLotDAL.dll` assembly (be sure you pick version 2.0.0.0!) and import the following namespace:

```
using AutoLotDAL2.DisconnectedLayer;
```

The design of the form consists of a single Label, DataGridView (named `inventoryGrid`), and Button control (named `btnUpdateInventory`), which you configure to handle the Click event. Here is the definition of the form:

```
public partial class MainForm : Form
{
    InventoryDALDC _dal = null;

    public MainForm()
    {
        InitializeComponent();

        string cnStr =
            @"Data Source=(local)\SQLEXPRESS2014;Initial Catalog=AutoLot;" +
            "Integrated Security=True;Pooling=False";

        // Create our data access object.
        _dal = new InventoryDALDC(cnStr);

        // Fill up our grid!
        inventoryGrid.DataSource = _dal.GetAllInventory();
    }

    private void btnUpdateInventory_Click(object sender, EventArgs e)
    {
        // Get modified data from the grid.
        DataTable changedDT = (DataTable)inventoryGrid.DataSource;

        try
        {
            // Commit our changes.
            _dal.UpdateInventory(changedDT);
            inventoryGrid.DataSource = _dal.GetAllInventory();
        }
        catch(Exception ex)
        {
            MessageBox.Show(ex.Message);
        }
    }
}
```

After you create the `InventoryDALDC` object, you can bind the `DataTable` returned from `GetAllInventory()` to the `DataGridView` object. When the user clicks the Update button, you extract the modified `DataTable` from the grid (with the `DataSource` property) and pass it into your `UpdateInventory()` method.

That's it! After you run this application, add a set of new rows to the grid and update/delete a few others. Assuming you click the `Button` control, you will see your changes have persisted into the `AutoLot` database. Because of the way data binding works with Windows Forms, you need to reset the `DataSource` on the `Grid` for the changes to show up immediately. As you will see when you build applications with Windows Presentation Foundation (WPF), the `Observable` pattern fixes this behavior.

■ **Source Code** You can find the updated `InventoryDALDisconnectedGUI` project in the [Chapter 22](#) subdirectory.

Multitabled DataSet Objects and Data Relationships

So far, all of this chapter's examples have operated on a single `DataTable` object. However, the power of the disconnected layer shines through when a `DataSet` object contains numerous interrelated `DataTables`. In this case, you can define any number of `DataRelation` objects in the `DataSet`'s `DataRelation` collection to account for the interdependencies of the tables. The client tier can use these objects to navigate between the table data without incurring network round-trips.

■ **Note** Rather than updating `AutoLotDAL.dll` to account for the `Customers` and `Orders` tables, this example isolates all the data access logic within a new Windows Forms project. However, intermixing UI and data logic in a production-level application is not recommended. The final examples of this chapter leverage various database design tools to decouple the UI logic from the data logic code.

Begin this example by creating a new Windows Forms application named `MultitabledDataSetApp`. The GUI is simple enough (note I changed the name of my initial `Form1.cs` file to `MainForm.cs` and the text property to `AutoLot Database Manipulator`). In [Figure 22-11](#), you can see three `DataGridView` widgets (`dataGridViewInventory`, `dataGridViewCustomers`, and `dataGridViewOrders`) that hold the data retrieved from the `Inventory`, `Customers`, and `Orders` tables of the `AutoLot` database. In addition, the initial `Button` (named `btnUpdateDatabase`) submits all changes entered within the grids to the database for processing using data adapter objects.

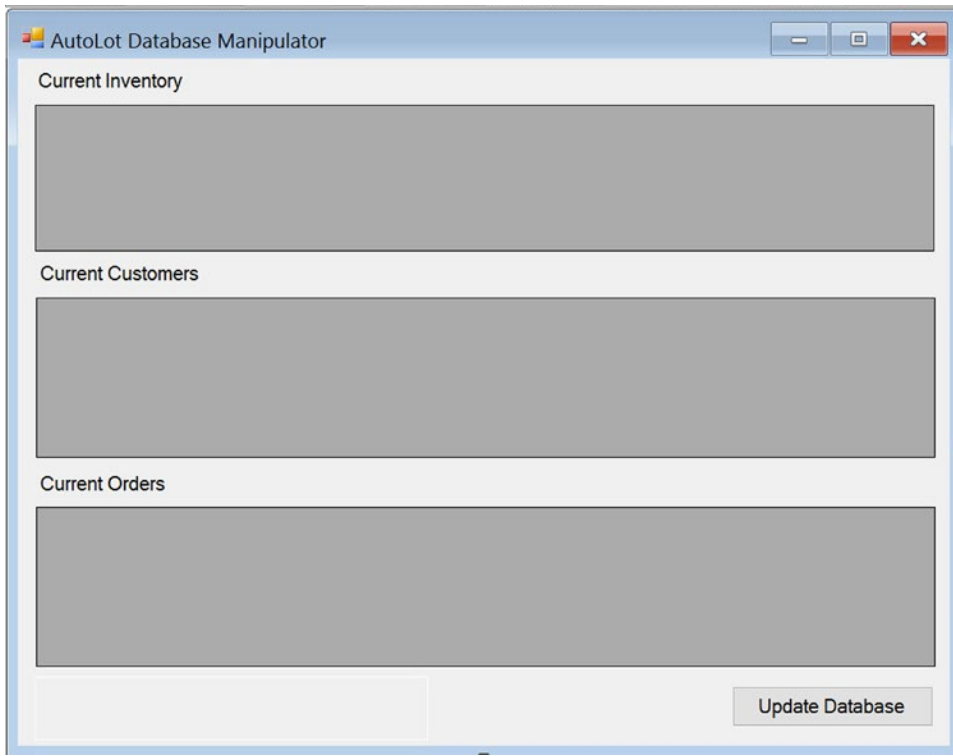

Figure 22-11. The initial UI will display data from each table of the AutoLot database

Prepping the Data Adapters

To keep the data access code as simple as possible, the `MainForm` will use command builder objects to autogenerate the SQL commands for each of the three `SqlDataAdapters` (one for each table). Here is the initial update to the Form-derived type (don't forget to import the `System.Data.SqlClient` namespace):

```
public partial class MainForm : Form
{
    // Form wide DataSet.
    private DataSet _autoLotDs = new DataSet("AutoLot");

    // Make use of command builders to simplify data adapter configuration.
    private SqlCommandBuilder _sqlCbInventory;
    private SqlCommandBuilder _sqlCbCustomers;
    private SqlCommandBuilder _sqlCbOrders;

    // Our data adapters (for each table).
    private SqlDataAdapter _invTableAdapter;
    private SqlDataAdapter _custTableAdapter;
    private SqlDataAdapter _ordersTableAdapter;

    // Form wide connection string.
    private string _connectionString;
    ...
}
```

The constructor does the grunt work of creating your data-centric member variables and filling the DataSet. This example assumes you have authored an App.config file that contains the correct connection string data (and that you have referenced System.Configuration.dll and imported the System.Configuration namespace), as in this example:

```
<configuration>
  <startup>
    <supportedRuntime version="v4.0" sku=".NETFramework,Version=v4.6" />
  </startup>
  <connectionStrings>
    <add name="AutoLotSqlProvider" connectionString =
      "Data Source=(local)\SQLEXPRESS2014;
        Integrated Security=SSPI;Initial Catalog=AutoLot"
    />
  </connectionStrings>
</configuration>
```

Also note that you include a call to a private helper function, BuildTableRelationship(), as follows:

```
public MainForm()
{
  InitializeComponent();

  // Get connection string.
  _connectionString =
    ConfigurationManager.ConnectionStrings["AutoLotSqlProvider"]
      .ConnectionString;

  // Create adapters.
  _invTableAdapter = new SqlDataAdapter(
    "Select * from Inventory", _connectionString);
  _custTableAdapter = new SqlDataAdapter(
    "Select * from Customers", _connectionString);
  _ordersTableAdapter = new SqlDataAdapter(
    "Select * from Orders", _connectionString);

  // Autogenerate commands.
  _sqlCbInventory = new SqlCommandBuilder(_invTableAdapter);
  _sqlCbOrders = new SqlCommandBuilder(_ordersTableAdapter);
  _sqlCbCustomers = new SqlCommandBuilder(_custTableAdapter);

  // Fill tables in DataSet.
  _invTableAdapter.Fill(_autoLotDs, "Inventory");
  _custTableAdapter.Fill(_autoLotDs, "Customers");
  _ordersTableAdapter.Fill(_autoLotDs, "Orders");

  // Build relations between tables.
  BuildTableRelationship();

  // Bind to grids
  dataGridViewInventory.DataSource = _autoLotDs.Tables["Inventory"];
  dataGridViewCustomers.DataSource = _autoLotDs.Tables["Customers"];
  dataGridViewOrders.DataSource = _autoLotDs.Tables["Orders"];
}
```

Building the Table Relationships

The `BuildTableRelationship()` helper function does the grunt work to add two `DataRelation` objects into the `autoLotDS` object. Recall from Chapter 21 that the `AutoLot` database expresses a number of parent-child relationships, which you can account for with the following code:

```
private void BuildTableRelationship()
{
    //Create CustomerOrder data relation object.
    DataRelation dr = new DataRelation("CustomerOrder",
        _autoLotDs.Tables["Customers"].Columns["CustID"],
        _autoLotDs.Tables["Orders"].Columns["CustID"]);
    _autoLotDs.Relations.Add(dr);

    // Create InventoryOrder data relation object.
    dr = new DataRelation("InventoryOrder",
        _autoLotDs.Tables["Inventory"].Columns["CarID"],
        _autoLotDs.Tables["Orders"].Columns["CarID"]);
    _autoLotDs.Relations.Add(dr);
}
```

Note that you establish a friendly string moniker with the first parameter when you create a `DataRelation` object (you'll see the usefulness of doing so in just a minute). You also establish the keys used to build the relationship itself. Notice that the parent table (the second constructor parameter) is specified before the child table (the third constructor parameter).

Updating the Database Tables

Now that the `DataSet` has been filled with data from the data source, you can manipulate each `DataTable` locally. To do so, run the application and insert, update, or delete values from any of the three `DataGridViews`. When you are ready to submit the data back for processing, click the Update button. You should find it easy to follow along with the code behind the related Click event at this point.

```
private void btnUpdateDatabase_Click(object sender, EventArgs e)
{
    try
    {
        _invTableAdapter.Update(_autoLotDs, "Inventory");
        _custTableAdapter.Update(_autoLotDs, "Customers");
        _ordersTableAdapter.Update(_autoLotDs, "Orders");
    }
    catch (Exception ex)
    {
        MessageBox.Show(ex.Message);
    }
}
```

Now run your application and perform various updates. When you rerun the application, you should find that your grids are populated with the recent changes.

Navigating Between Related Tables

Now let's look at how a `DataRelation` allows you to move between related tables programmatically. Extend your UI to include a new `Button` (named `btnGetOrderInfo`), a related `TextBox` (named `txtCustID`), and a descriptive `Label` (you can group these controls within a `GroupBox` for more visual appeal).

Figure 22-12 shows one possible UI of the application.

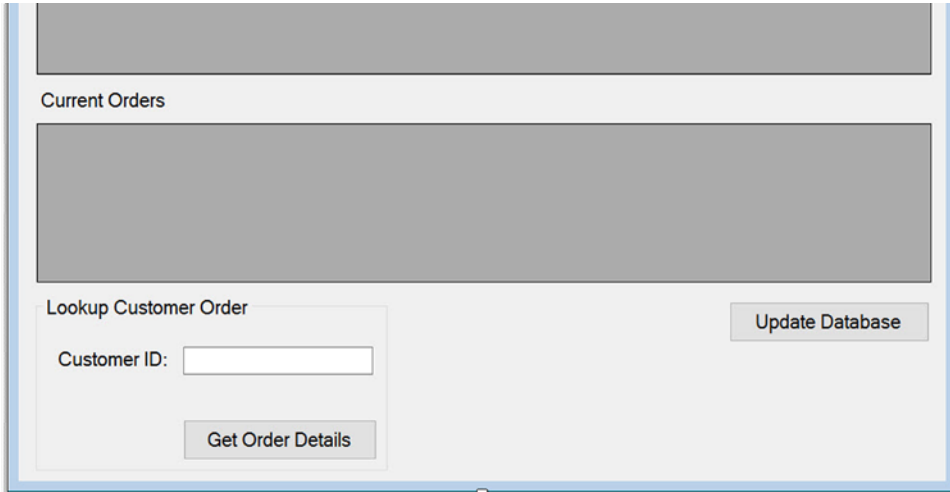

Figure 22-12. The updated UI allows the user to look up customer order information

This updated UI lets the user enter the ID of a customer and retrieve all the relevant information about that customer's order (e.g., name, order ID, and car order). This information will be formatted into a `string` type that is eventually displayed within a message box. Consider the following code behind the new `Button`'s `Click` event handler:

```
private void btnGetOrderInfo_Click(object sender, EventArgs e)
{
    string strOrderInfo = string.Empty;

    // Get the customer ID in the text box.
    int custID = int.Parse(txtCustID.Text);

    // Now based on custID, get the correct row in Customers table.
    var drsCust = _autoLotDs.Tables["Customers"].Select($"CustID = {custID}");
    strOrderInfo +=
        $"Customer {drsCust[0]["CustID"]}: {drsCust[0]["FirstName"].ToString().Trim()}
{drsCust[0]["LastName"].ToString().Trim()}\n";

    // Navigate from customer table to order table.
    var drsOrder = drsCust[0].GetChildRows(_autoLotDs.Relations["CustomerOrder"]);

    // Loop through all orders for this customer.
    foreach (DataRow order in drsOrder)
    {
        strOrderInfo += $"----\nOrder Number: {order["OrderID"]}\n";
    }
}
```

```

// Get the car referenced by this order.
DataRow[] drsInv = order.GetParentRows(_autoLotDs.Relations["InventoryOrder"]);

// Get info for (SINGLE) car info for this order.
DataRow car = drsInv[0];
strOrderInfo += $"Make: {car["Make"]}\n";
strOrderInfo += $"Color: {car["Color"]}\n";
strOrderInfo += $"Pet Name: {car["PetName"]}\n";
}

MessageBox.Show(strOrderInfo, "Order Details");
}

```

Figure 22-13 shows one possible output when specifying a customer ID with the value of 3 (your output may differ based on the data within your AutoLot database tables).

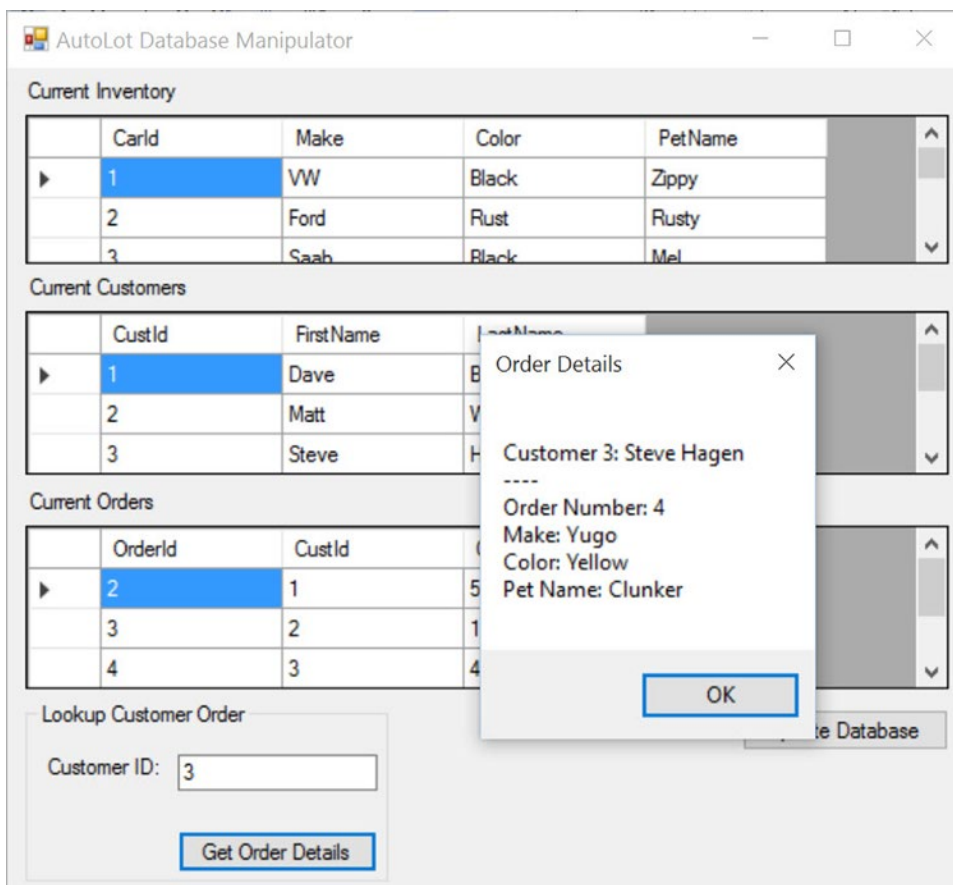

Figure 22-13. Navigating data relations

This previous example should probably convince you of the usefulness of the `DataSet` class. Given that a `DataSet` is completely disconnected from the underlying data source, you can work with an in-memory copy of data and navigate around each table to make any necessary updates, deletes, or inserts without incurring any round-trips to the database. After you finish this, you can submit your changes to the data store for processing. The end result is a scalable and robust application.

■ **Source Code** You can find the `MultitabledDataSetApp` project in the [Chapter 22](#) subdirectory.

The Windows Forms Database Designer Tools

All the examples thus far have involved a fair amount of elbow grease in the sense that you had to author all data access logic by hand. While you did offload a good amount of this code to a .NET code library (`AutoLotDAL.dll`) for reuse in later chapters of the book, you still had to create the various objects of your data provider manually before interacting with the relational database. The next task in this chapter is to look at how you use various Windows Forms database designer tools, which can produce a good deal of data access code on your behalf.

One way you can use these integrated tools is to use the designers supported by the Windows Forms `DataGridView` control. The problem with this approach is that the database designer tools will embed all the data access code directly into your GUI code base! Ideally, you want to isolate all this designer-generated code in a dedicated .NET code library, so you can easily reuse your database access logic across multiple projects.

Nevertheless, it might be helpful to begin with an examination of how you can use the `DataGridView` control to generate the required data access code, given that this approach does have some usefulness in small-scale projects and application prototypes. After this point, you will learn how to isolate the same designer-generated code into a third version of `AutoLotDAL.dll`.

Visually Designing the `DataGridView`

The `DataGridView` control has an associated wizard that can generate data access code on your behalf. Begin by creating a new Windows Forms application project named `DataGridViewDataDesigner`. Rename the initial form to `MainForm.cs` using the Solution Explorer, set `Text` to `Windows Forms Data Wizards`, and then add an instance of the `DataGridView` control (named `inventoryDataGridView`) to your initial form. When you select your `DataGridView` control, an inline editor should open to the right side of the control (if not, just click the small “triangle” button found on the upper right of the control). From the `Choose Data Source` drop-down box, select the `Add Project Data Source` link (see [Figure 22-14](#)).

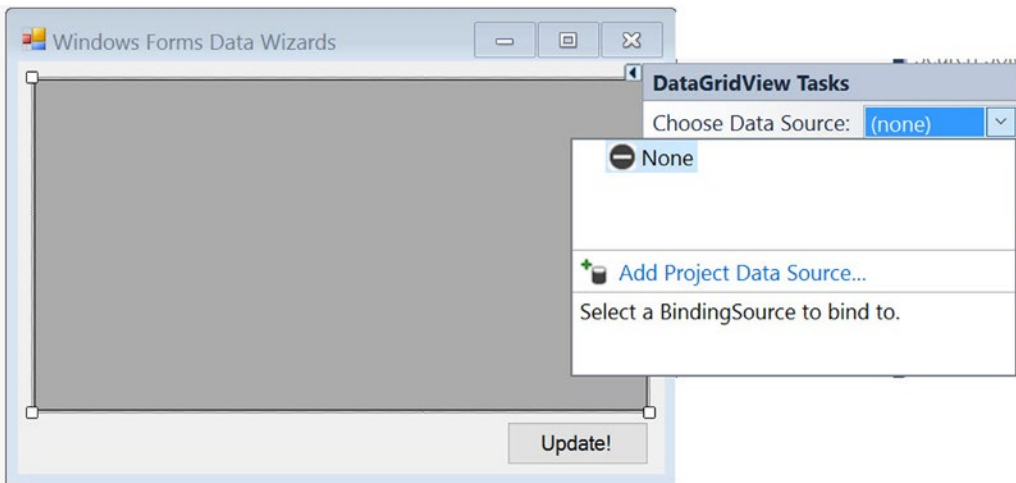

Figure 22-14. The DataGridView editor

This launches the Data Source Configuration Wizard. This tool guides you through a series of steps that allow you to select and configure a data source, which you can then bind to the DataGridView. The first step of the wizard asks you to identify the type of data source you want to interact with. Select Database (see Figure 22-15) and click the Next button.

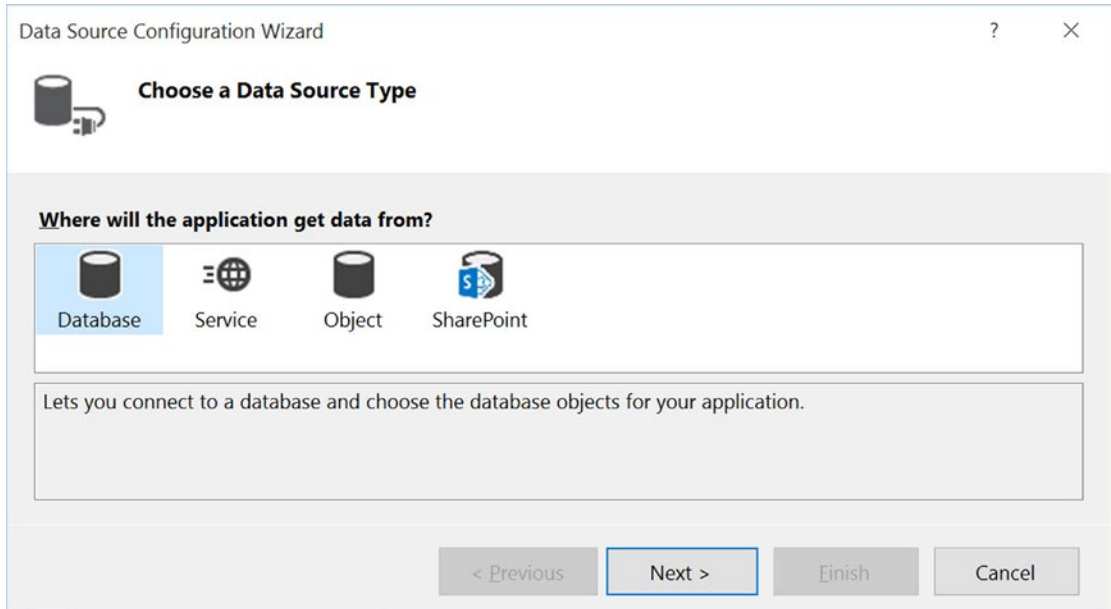

Figure 22-15. Selecting the type of data source

The next step (which will differ slightly based on your selection in step 1) asks what type of database model to use. You will see the Dataset database model only if you've added the Entity Framework to your project. Pick the Dataset database model (see Figure 22-16).

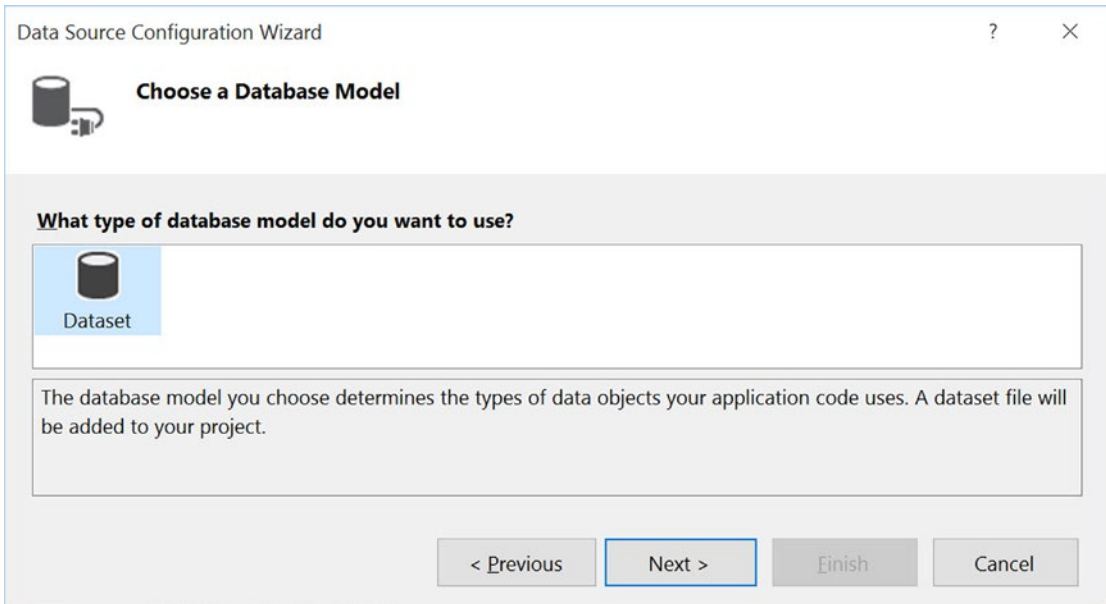

Figure 22-16. Choosing the database model

The next step allows you to configure your database connection. If you have a database currently added to Server Explorer, you should find it listed automatically in the drop-down list. If this is not the case (or if you ever need to connect to a database you have not previously added to Server Explorer), click the New Connection button. Figure 22-17 shows the result of selecting the local instance of AutoLot.

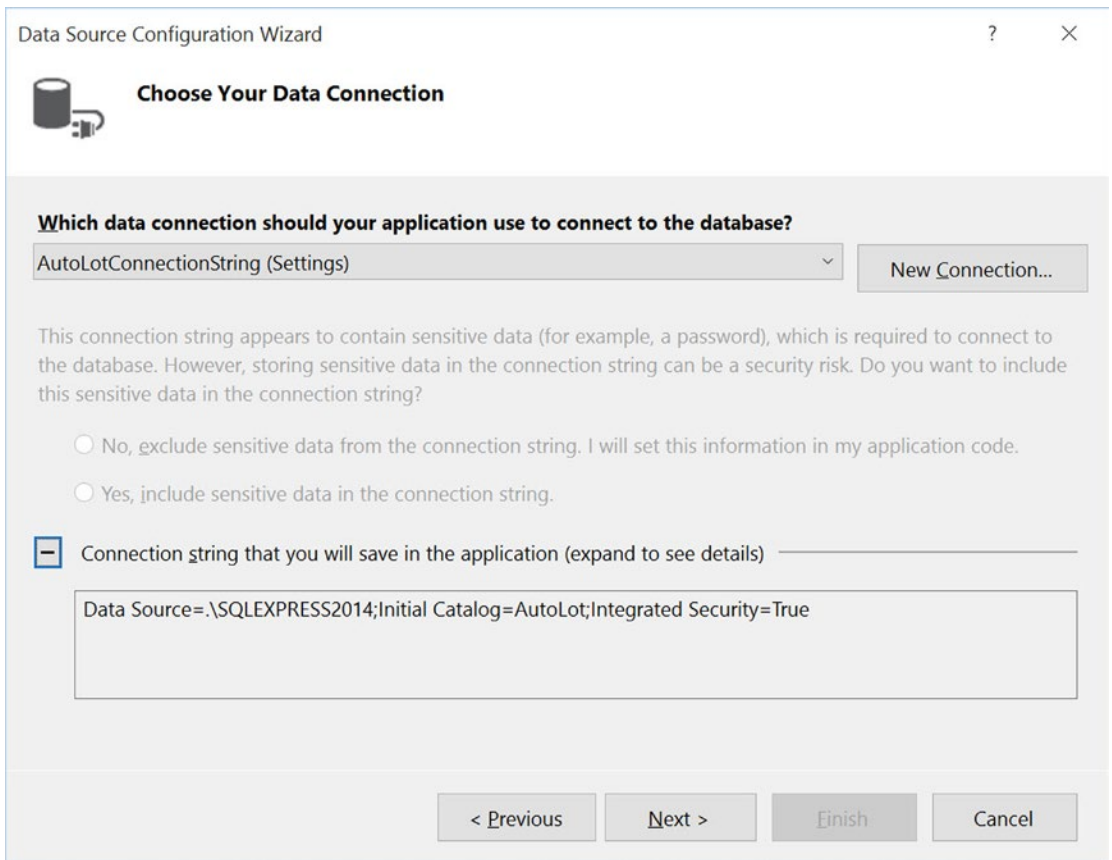

Figure 22-17. Choosing the database

In the wizard's next step, you will be asked if you would like to save the connection string in an application configuration file as in Figure 22-18. Elect to save your connection string and then click the Next button.

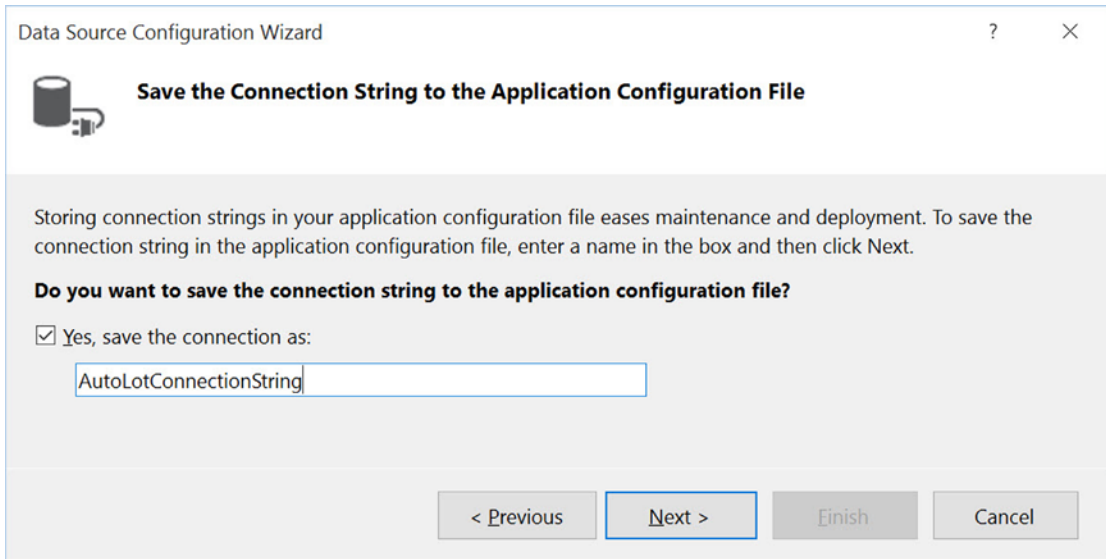

Figure 22-18. Saving the connection string in the `app.config` file

In the final step, you select the database objects that will be accounted for by the autogenerated DataSet and related data adapters. While you could select each of the data objects of the AutoLot database, here you concern yourself only with the Inventory table. Given this, change the suggested name of the DataSet to InventoryDataSet (see Figure 22-19), check the Inventory table, and click the Finish button.

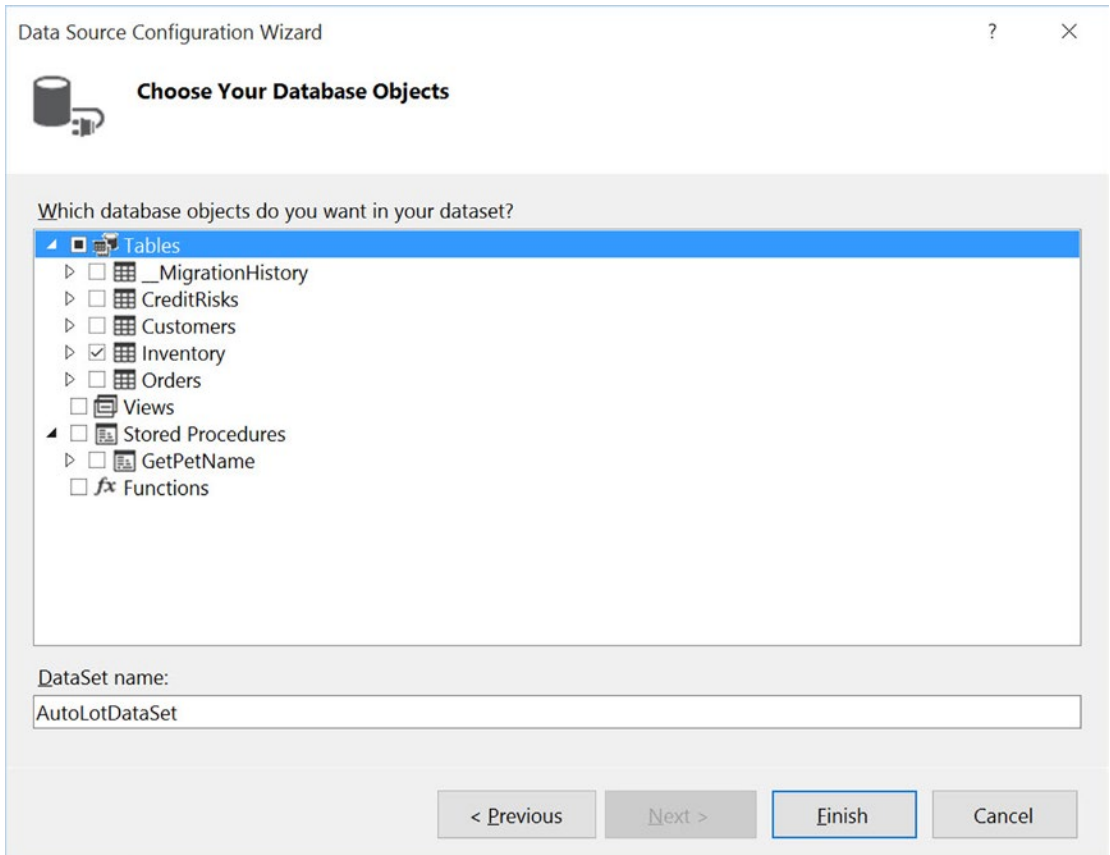

Figure 22-19. Selecting the Inventory table

After you do this, you will see that the visual designer has been updated in many ways. The most noticeable change is that the `DataGridView` displays the schema of the `Inventory` table, as illustrated by the column headers. Also, you will see three components on the bottom of the form designer (in a region dubbed the *component tray*): a `DataSet` component, a `BindingSource` component, and a `TableAdapter` component (see Figure 22-20).

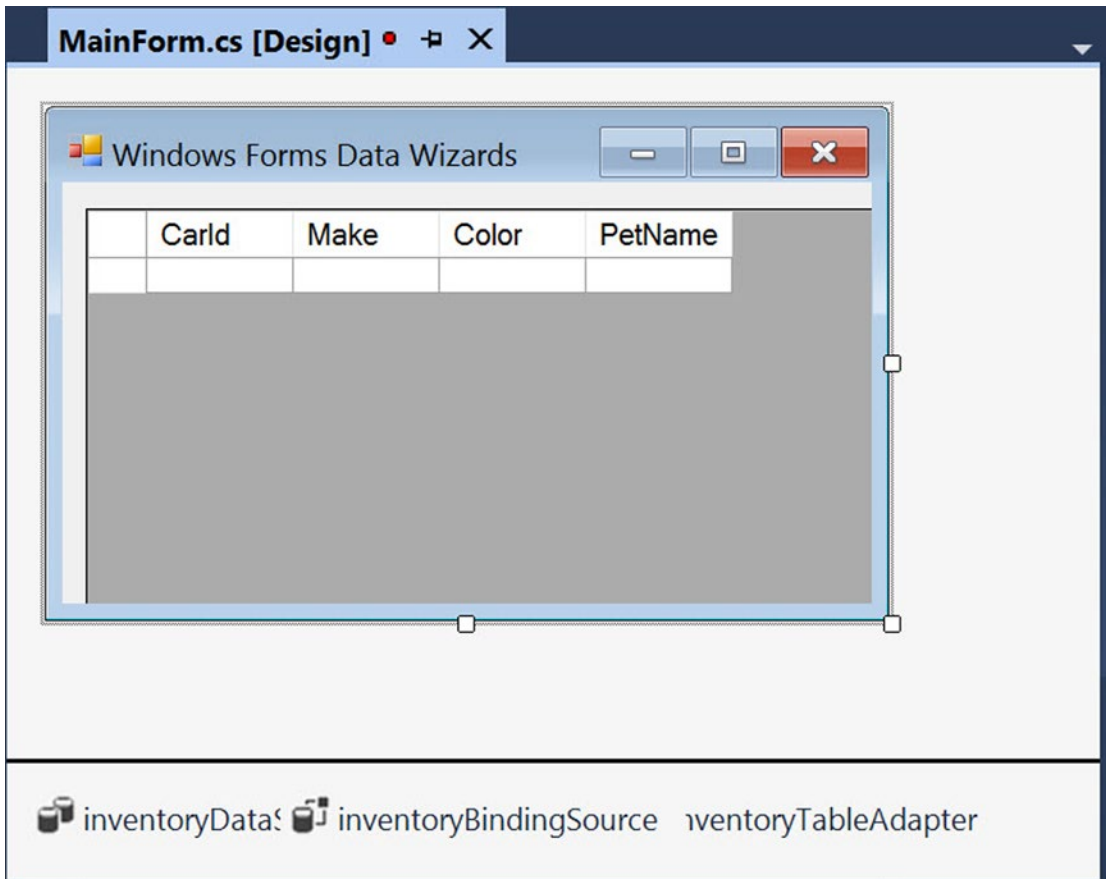

Figure 22-20. Your Windows Forms project, after running the Data Source Configuration Wizard

At this point, you can run your application, and lo and behold, the grid is filled with the records of the `Inventory` table! Of course, there is no magic to speak of in this case. The IDE has authored a good amount of code on your behalf and set up the grid control to use it. Let's dig into some of this autogenerated code.

The Generated App.config File

If you examine your Solution Explorer, you will find your project now contains an App.config file that contains a <connectionStrings> element that has been given a somewhat peculiar name, as shown here:

```
<?xml version="1.0" encoding="utf-8" ?>
<configuration>
  <configSections>
  </configSections>
  <connectionStrings>
    <add name="DataGridViewDataDesigner.Properties.Settings.AutoLotConnectionString"
        connectionString="Data Source=.\SQLEXPRESS2014;Initial Catalog=AutoLot;Integrated
        Security=True"
        providerName="System.Data.SqlClient" />
  </connectionStrings>
  <startup>
    <supportedRuntime version="v4.0" sku=".NETFramework,Version=v4.6" />
  </startup>
</configuration>
```

The autogenerated data adapter object (which you will learn more about momentarily) uses the lengthy value, "DataGridViewDataDesigner.Properties.Settings.AutoLotConnectionString".

Examining the Strongly Typed DataSet

In addition to your configuration file, the data wizard tools generated what is termed a *strongly typed DataSet*. This term describes a custom class that extends DataSet and exposes a number of members that allow you to interact with the database using a more intuitive object model. For example, strongly typed DataSet objects contain properties that map directly to the database table names. Thus, you can use the Inventory property to nab the rows and columns directly, rather than having to drill into the collection of tables using the Tables property.

If you insert a new class diagram file into your project, you'll notice that the wizard has created a class named InventoryDataSet. This class defines a handful of members, the most important of which is a property named Inventory (see Figure 22-21).



Figure 22-21. The Data Source Configuration Wizard created a strongly typed DataSet

If you double-click the `InventoryDataSet.xsd` file within Solution Explorer, you will load the Visual Studio Dataset Designer (you'll learn more details about this designer momentarily). If you right-click anywhere within this designer and select the View Code option, you will notice the following fairly empty partial class definition:

```
partial class InventoryDataSet {
}
```

If necessary, you can add custom members to this partial class definition; however, the real action takes place within the designer-maintained file, `InventoryDataSet.Designer.cs`. If you open this file using Solution Explorer, you will see that `InventoryDataSet` extends the `DataSet` parent class. Consider the following partial code, with comments added for clarity:

```
// This is all designer-generated code!
public partial class InventoryDataSet : global::System.Data.DataSet
{
    // A member variable of type InventoryDataTable.
    private InventoryDataTable tableInventory;

    // Each constructor calls a helper method named InitClass().
    public InventoryDataSet()
    {
        ...
        this.InitClass();
        ...
    }

    // InitClass() preps the DataSet and adds the InventoryDataTable
// to the Tables collection.
    private void InitClass()
    {
        this.DataSetName = "InventoryDataSet";
        this.Prefix = "";
        this.Namespace = "http://tempuri.org/InventoryDataSet.xsd";
        this.EnforceConstraints = true;
        this.SchemaSerializationMode =
            global::System.Data.SchemaSerializationMode.IncludeSchema;
        this.tableInventory = new InventoryDataTable();
        base.Tables.Add(this.tableInventory);
    }

    // The read-only Inventory property returns
// the InventoryDataTable member variable.
    public InventoryDataTable Inventory
    {
        get { return this.tableInventory; }
    }
}
```

Notice that your strongly typed `DataSet` has a member variable that is a *strongly typed DataTable*; in this case, the class is named `InventoryDataTable`. The constructor of the strongly typed `DataSet` class makes a call to a private initialization method named `InitClass()`, which adds an instance of this strongly typed `DataTable` to the `Tables` collection of the `DataSet`. Last but not least, notice that the implementation of the `Inventory` property returns the `InventoryDataTable` member variable.

Examining the Strongly Typed DataTable

Now return to the class diagram file and open up the Nested Types node on the InventoryDataSet icon. Here you will see the strongly typed DataTable class named InventoryDataTable and a *strongly typed* DataRow class named InventoryRow.

The InventoryDataTable class (which is the same type as the member variable of the strongly typed DataSet you examined) defines a set of properties that are based on the column names of the physical Inventory table (CarIDColumn, ColorColumn, MakeColumn, and PetNameColumn), as well as a custom indexer and a Count property to obtain the current number of records.

More interestingly, this strongly typed DataTable class defines a set of methods that allow you to insert, locate, and delete rows within the table using strongly typed members (an attractive alternative to navigating the Rows and Columns indexers manually). For example, AddInventoryRow() lets you add a new record row to the table in memory, FindByCarID() lets you do a lookup based on the primary key of the table, and RemoveInventoryRow() lets you remove a row from the strongly typed table (see Figure 22-22).

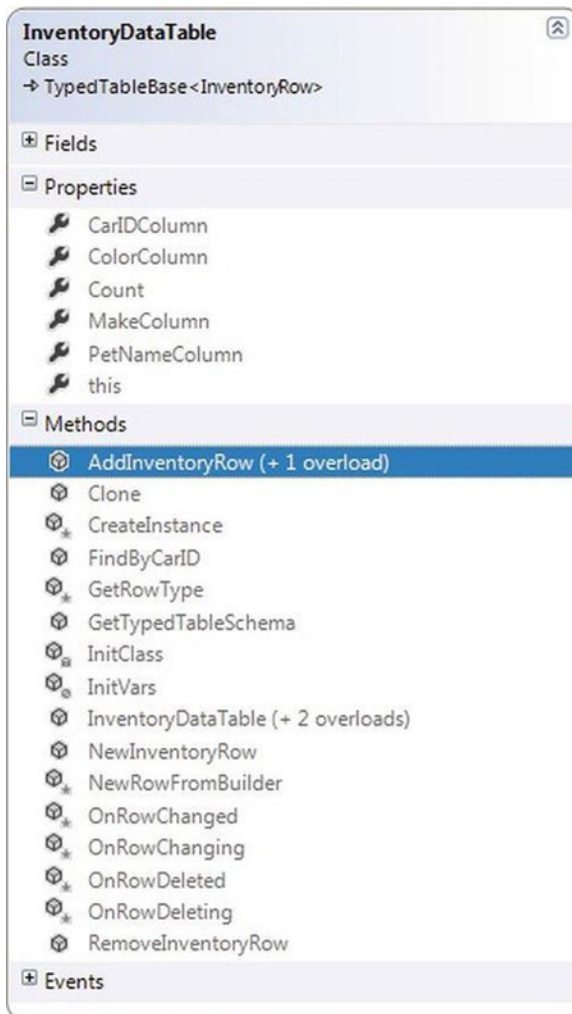

Figure 22-22. The strongly typed DataTable is nested in the strongly typed DataSet

Examining the Strongly Typed DataRow

The strongly typed DataRow class, which is also nested in the strongly typed DataSet, extends the DataRow class and exposes properties that map directly to the schema of the Inventory table. Also, the data designer tool has created a method (IsPetNameNull()) that will perform a check on whether this column has a value (see Figure 22-23).

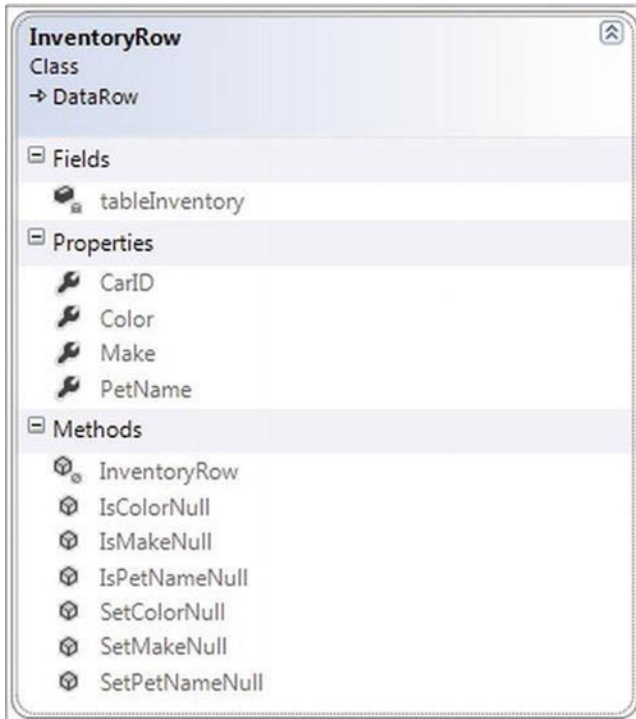

Figure 22-23. The strongly typed DataRow

Examining the Strongly Typed Data Adapter

Strong typing for your disconnected types is a solid benefit of using the Data Source Configuration Wizard, given that creating these classes by hand would be tedious (but entirely possible). This same wizard was kind enough to generate a custom data adapter object that can fill and update the `InventoryDataSet` and `InventoryDataTable` objects in a strongly typed manner. Locate the `InventoryTableAdapter` on the visual class designer and examine the generated members in Figure 22-24.



Figure 22-24. A customized data adapter that operates on the strongly typed `DataSet` and `DataTable`

The autogenerated `InventoryTableAdapter` type maintains a collection of `SqlCommand` objects (which you can access using the `CommandCollection` property), each of which has a fully populated set of `SqlParameter` objects. Furthermore, this custom data adapter provides a set of properties to extract the underlying connection, transaction, and data adapter objects, as well as a property to obtain an array representing each command type.

Completing the Windows Forms Application

If you examine the `Load` event handler of the form-derived type (in other words, if you view the code for `MainForm.cs` and locate the `MainForm_Load()` method), you will find that the `Fill()` method of the custom table adapter is called upon startup, passing in the custom `DataTable` maintained by the custom `DataSet`.

```
private void MainForm_Load(object sender, EventArgs e)
{
    this.inventoryTableAdapter.Fill(this.inventoryDataSet.Inventory);
}
```

You can use this same custom data adapter object to update changes to the grid. Update the UI of your form with a single `Button` control (named `btnUpdateInventory`). Next, handle the `Click` event and author the following code within the event handler:

```
private void btnUpdateInventory_Click(object sender, EventArgs e)
{
    try
    {
        // Save changes with the Inventory table back to the database.
        this.inventoryTableAdapter.Update(this.inventoryDataSet.Inventory);
    }
    catch(Exception ex)
    {
        MessageBox.Show(ex.Message);
    }

    // Get fresh copy for grid.
    this.inventoryTableAdapter.Fill(this.inventoryDataSet.Inventory);
}
```

Run your application again; add, delete, or update the records displayed in the grid; and click the `Update` button. When you run the program again, you will find your changes are present and accounted for.

Great! This example shows how helpful the `DataGridView` control designer can be. It lets you work with strongly typed data and generates a majority of the necessary database logic on your behalf. The obvious problem is that this code is tightly connected to the window that uses it. Ideally, this sort of code belongs in your `AutoLotDAL.dll` assembly (or some other data access library). However, you might wonder how to harvest the code generated using the `DataGridView`'s associated wizard in a `Class Library` project, given that there is no form designer by default.

■ **Source Code** You can find the `DataGridViewDataDesigner` project in the [Chapter 22](#) subdirectory.

Isolating Strongly Typed Database Code into a Class Library

Fortunately, you can activate the data design tools of Visual Studio from any sort of project (UI-based or otherwise) without the need to copy and paste massive amounts of code between projects. You can see this in action by adding more functionality to `AutoLotDAL.dll`. You can continue working with your existing project. In the downloaded code for the chapter, the code for the next section is in a separate project named `AutoLotDAL3.dll`.

Create a new folder named `DataSets` in the project, and insert a new strongly typed `DataSet` class (named `AutoLotDataSet.xsd`) into your new folder using the Project ► Add New Item menu option (to quickly find the `DataSet` project type, select the `Data` section of the New Item dialog; see Figure 22-25).

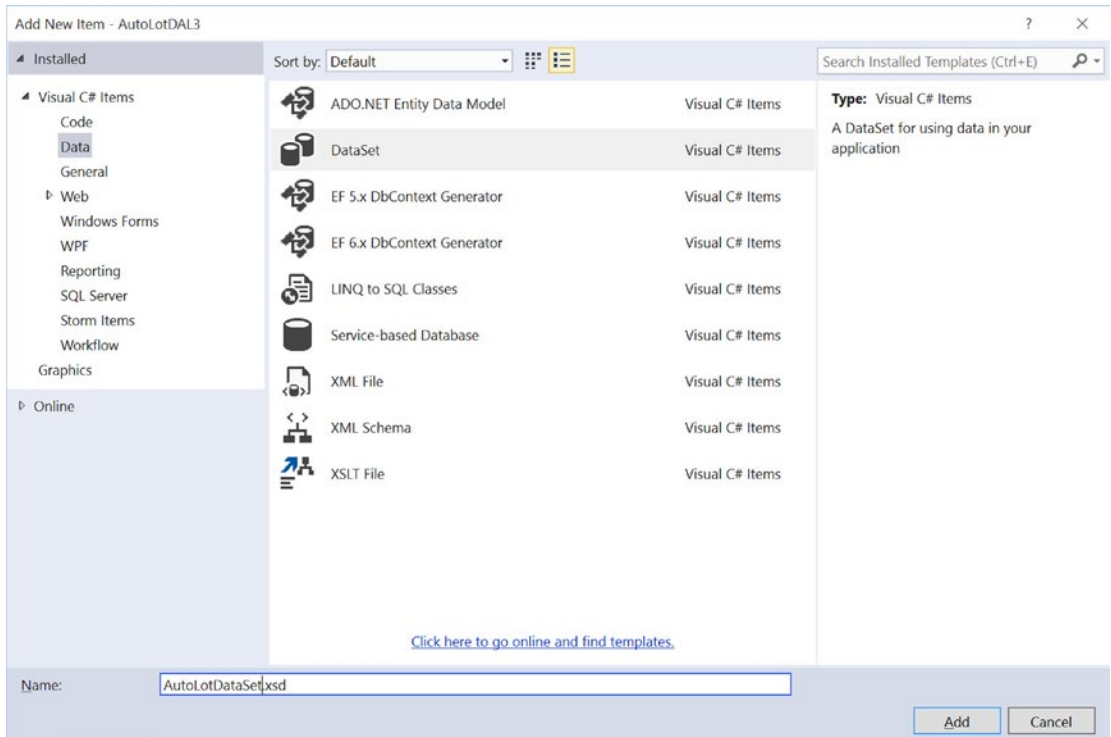

Figure 22-25. Inserting a new strongly typed `DataSet`

This opens a blank DataSet Designer surface. At this point, you can use the Server Explorer to connect to a given database (you should already have a connection to AutoLot) and then drag and drop each table and stored procedure you want in the DataSet onto the design surface. In Figure 22-26, you can see the custom aspects of AutoLot are accounted for, and their relationships are realized automatically (this example does not drag over the CreditRisk table).

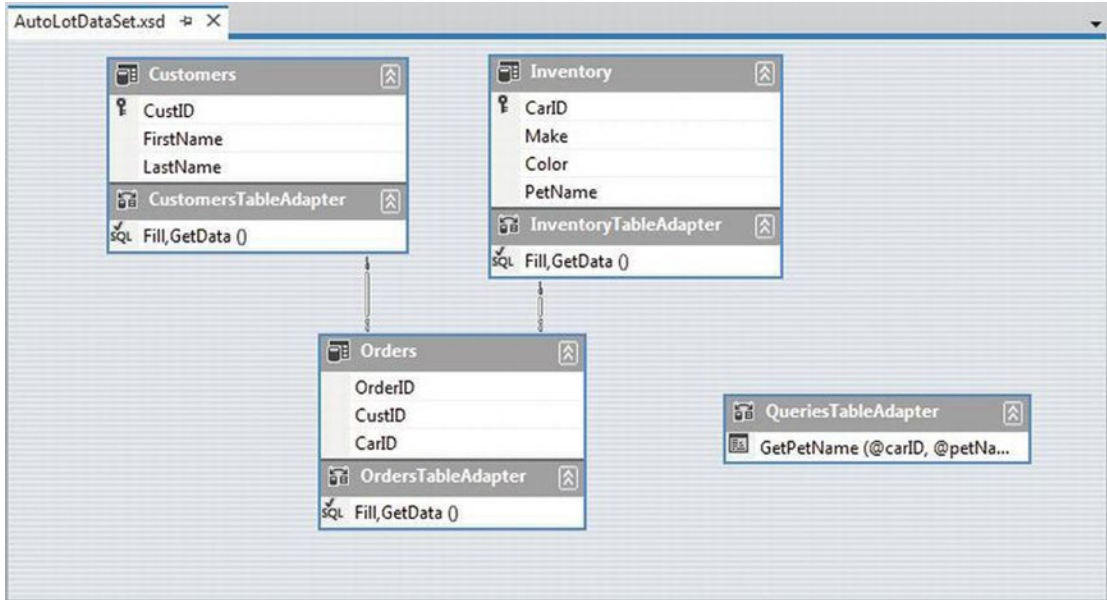

Figure 22-26. Your custom strongly typed types, this time within a Class Library project

Viewing the Generated Code

The DataSet designer created the same sort of code that the DataGridView wizard did in the previous Windows Forms example. However, this time you account for the Inventory, Customers, and Orders tables, as well as the GetPetName stored procedure, so you have many more generated classes. Basically, each database table you drag onto the designer surface gives you DataTable, DataRow, and data adapter classes contained in a strongly typed DataSet.

The strongly typed DataSet, DataTable, and DataRow classes will be placed into the root namespace of the project (AutoLotDAL). The custom table adapters will be placed within a nested namespace. You can view all the generated types most easily by using the Class View tool, which you open from the Visual Studio View menu (see Figure 22-27).

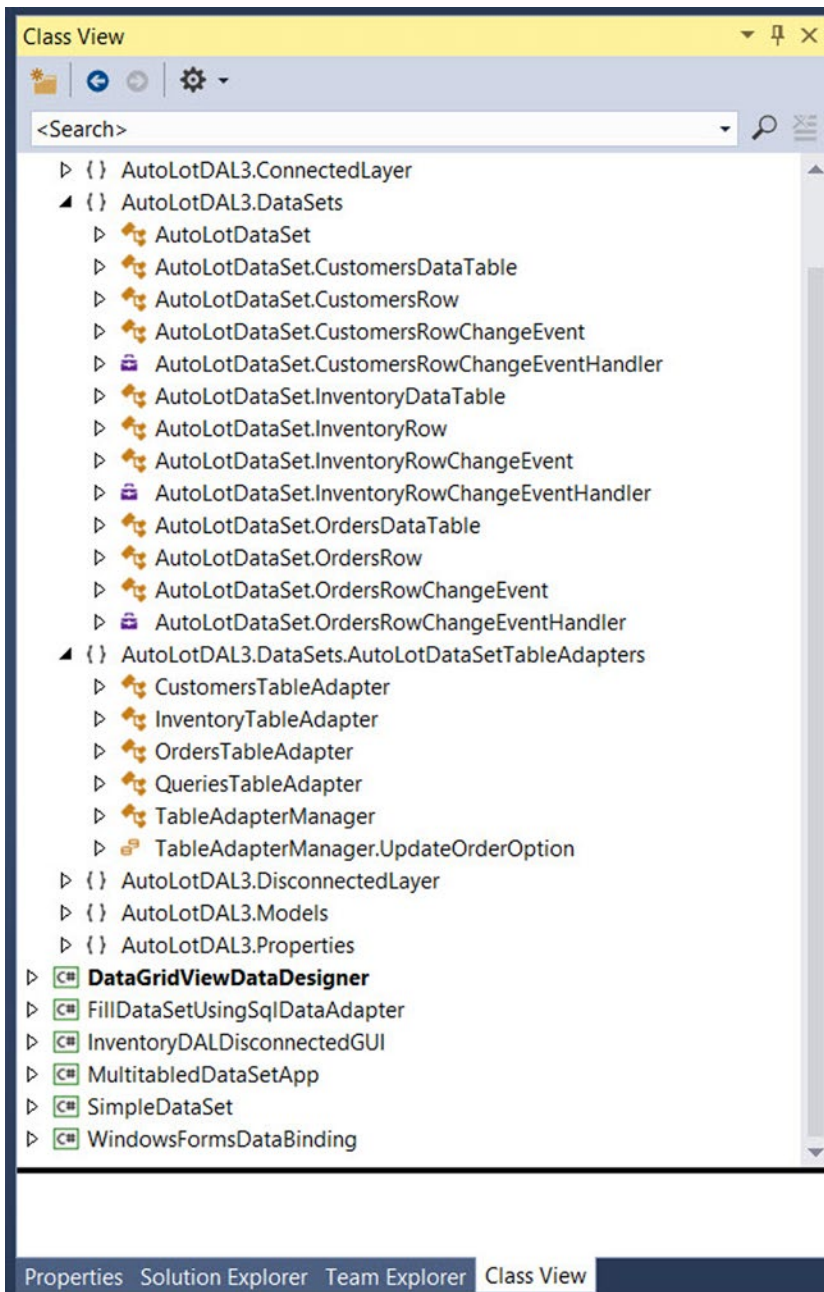

Figure 22-27. The autogenerated strongly typed data of the AutoLot database

For the sake of completion, you might want use the Visual Studio Properties editor (see Chapter 14 for details) to set the version of this latest incarnation of `AutoLotDAL.dll` to `3.0.0.0`.

■ **Source Code** You can find the `AutoLotDAL3` project in the Chapter 22 subdirectory.

Selecting Data with the Generated Code

At this point, you can use your strongly typed data within any .NET application that needs to communicate with the `AutoLot` database. To make sure you understand the basic mechanics, create a Console Application project named `StronglyTypedDataSetConsoleClient`. Next, add a reference to your latest-and-greatest version of `AutoLotDAL3.dll` and import the `AutoLotDAL3.DataSets`, `AutoLotDAL3.DataSets.AutoLotDataSetTableAdapters`, and static `System.Console` namespaces into your initial C# code file.

Here is a `Main()` method that uses the `InventoryTableAdapter` object to retrieve all data in the `Inventory` table. Notice that you do not need to specify a connection string because that information is now part of the strongly typed object model. After you fill the table, you print the results using a helper method named `PrintInventory()`. Note that you can manipulate the strongly typed `DataTable` just as you do a “normal” `DataTable` using the `Rows` and `Columns` collections.

```
class Program
{
    static void Main(string[] args)
    {
        Console.WriteLine("***** Fun with Strongly Typed DataSets *****\n");

        // Caller creates the DataSet object.
        var table = new AutoLotDataSet.InventoryDataTable();

        // Inform adapter of the Select command text and connection.
        var adapter = new InventoryTableAdapter();

        // Fill our DataSet with a new table, named Inventory.
        adapter.Fill(table);

        PrintInventory(table);    Console.ReadLine();
    }

    static void PrintInventory(AutoLotDataSet.InventoryDataTable dt)
    {
        // Print out the column names.
        for (int curCol = 0; curCol < dt.Columns.Count; curCol++)
        {
            Write(dt.Columns[curCol].ColumnName + "\t");
        }
        WriteLine("\n-----");
    }
}
```

```

// Print the DataTable.
for (int curRow = 0; curRow < dt.Rows.Count; curRow++)
{
    for (int curCol = 0; curCol < dt.Columns.Count; curCol++)
    {
        Write(dt.Rows[curRow][curCol] + "\t");
    }
    WriteLine();
}
}
}

```

Inserting Data with the Generated Code

Now assume you want to insert new records using this strongly typed object model. The following helper function adds two new rows to the current `InventoryDataTable` and then updates the database using the data adapter. You add the first row manually by configuring a strongly typed `DataRow`; you add the second row by passing in the needed column data, which allows the `DataRow` to be created in the background automatically.

```

public static void AddRecords(
    AutoLotDataSet.InventoryDataTable table,
    InventoryTableAdapter adapter)
{
    try
    {
        // Get a new strongly typed row from the table.
        AutoLotDataSet.InventoryRow newRow = table.NewInventoryRow();

        // Fill row with some sample data.
        newRow.Color = "Purple";
        newRow.Make = "BMW";
        newRow.PetName = "Saku";

        // Insert the new row.
        table.AddInventoryRow(newRow);

        // Add one more row, using overloaded Add method.
        table.AddInventoryRow("Yugo", "Green", "Zippy");

        // Update database.
        adapter.Update(table);
    }
    catch (Exception ex)
    {
        WriteLine(ex.Message);
    }
}

```

The `Main()` method can invoke this method; doing so updates the database table with these new records.

```
static void Main(string[] args)
{
    ...
    // Add rows, update, and reprint.
    AddRecords(table, adapter);
    table.Clear();
    adapter.Fill(table);
    PrintInventory(table);
    Console.ReadLine();
}
```

Deleting Data with the Generated Code

Deleting records with this strongly typed object model is also simple. The autogenerated `FindByXXXX()` method (where `XXXX` is the name of the primary key column) of the strongly typed `DataTable` returns the correct (strongly typed) `DataRow` using the primary key. Here is another helper method that deletes the two records you just created:

```
private static void RemoveRecords(
    AutoLotDataSet.InventoryDataTable table, InventoryTableAdapter adapter)
{
    try
    {
        AutoLotDataSet.InventoryRow rowToDelete = table.FindByCarId(1);
        adapter.Delete(rowToDelete.CarId, rowToDelete.Make, rowToDelete.Color,
            rowToDelete.PetName);
        rowToDelete = table.FindByCarId(2);
        adapter.Delete(rowToDelete.CarId, rowToDelete.Make, rowToDelete.Color,
            rowToDelete.PetName);
    }
    catch (Exception ex)
    {
        WriteLine(ex.Message);
    }
}
```

If you call this from your `Main()` method and reprint the table, you should find these two test records are no longer displayed.

■ Note If you want to make this example more flexible, you can gather data from the user using the `Console` class.

Invoking a Stored Procedure Using the Generated Code

Let's look at one more example of using the strongly typed object model. In this case, you create a final method that invokes the `GetPetName` stored procedure. When the data adapters for the `AutoLot` database were created, there was a special class created named `QueriesTableAdapter`, which, as the name implies, encapsulates the process of invoking stored procedures in the relational database. This final helper function displays the name of the specified car when called from `Main()`:

```
public static void CallStoredProc()
{
    try
    {
        var queriesTableAdapter = new QueriesTableAdapter();
        Write("Enter ID of car to look up: ");
        string carID = ReadLine() ?? "0";
        string carName = "";
        queriesTableAdapter.GetPetName(int.Parse(carID), ref carName);
        WriteLine($"CarID {carID} has the name of {carName}");
    }
    catch(Exception ex)
    {
        Console.WriteLine(ex.Message);
    }
}
```

At this point, you know how to use strongly typed database types and package them up into a dedicated class library. You can find more aspects of this object model to play around with, but you should be in a perfect position to dig deeper if that interests you. To wrap things up for this chapter, you will learn how to apply LINQ queries to an ADO.NET `DataSet` object.

■ **Source Code** You can find the `StronglyTypedDataSetConsoleClient` project in the [Chapter 22](#) subdirectory.

Programming with LINQ to DataSet

You have seen in this chapter that you can manipulate the data within a `DataSet` in three distinct manners:

- By using the `Tables`, `Rows`, and `Columns` collections
- By using data table readers
- By using strongly typed data classes

When you use the various indexers of the `DataSet` and `DataTable` type, you can interact with the contained data in a straightforward but loosely typed manner. Recall that this approach requires you to treat the data as a tabular block of cells, as in this example:

```
static void PrintDataWithIndexers(DataTable dt)
{
    // Print the DataTable.
    for (int curRow = 0; curRow < dt.Rows.Count; curRow++)
    {
        for (int curCol = 0; curCol < dt.Columns.Count; curCol++)
        {
            Write(dt.Rows[curRow][curCol] + "\t");
        }
        WriteLine();
    }
}
```

The `CreateDataReader()` method of the `DataTable` type offers a second approach, where you can treat the data in the `DataSet` as a linear set of rows to be processed in a sequential manner. This allows you to apply a connected data reader programming model to a disconnected `DataSet`.

```
static void PrintDataWithDataTableReader(DataTable dt)
{
    // Get the DataTableReader type.
    DataTableReader dtReader = dt.CreateDataReader();
    while (dtReader.Read())
    {
        for (int i = 0; i < dtReader.FieldCount; i++)
        {
            Write($"{dtReader.GetValue(i)}\t");
        }
        WriteLine();
    }
    dtReader.Close();
}
```

Finally, you can use a strongly typed `DataSet` to yield a code base that allows you to interact with data in the object using properties that map to the column names in the relational database. Using strongly typed objects allows you to author code such as the following:

```
static void AddRowWithTypedDataSet()
{
    InventoryTableAdapter invDA = new InventoryTableAdapter();
    AutoLotDataSet.InventoryDataTable inv = invDA.GetData();
    inv.AddInventoryRow("Ford", "Yellow", "Sal");
    invDA.Update(inv);
}
```

While all of these approaches have their place, the LINQ to `DataSet` API provides yet another option to manipulate `DataSet` data using LINQ query expressions.

■ **Note** You use the LINQ to DataSet API to apply LINQ queries only to DataSet objects returned by a data adapter, but this has nothing to do with applying LINQ queries directly to the database engine. Chapter 23 will introduce you to the ADO.NET Entity Framework, which provides a way to represent SQL queries as LINQ queries.

Out of the box, the ADO.NET DataSet (and related types such as DataTable and DataView) do not have the necessary infrastructure to be a direct target for a LINQ query. For example, the following method (which uses types in the `AutoLotDisconnectedLayer` namespace) results in a compile-time error:

```
static void LinqOverDataTable()
{
    // Get a DataTable of data.
    InventoryDALDC dal = new InventoryDALDC(
        @"Data Source=(local)\SQLEXPRESS2014;Initial Catalog=AutoLot;Integrated Security=True");
    DataTable data = dal.GetAllInventory();
    // Apply a LINQ query to the DataSet?
    var moreData = from c in data where (int)c["CarID"] > 5 select c;
}
```

If you were to compile the `LinqOverDataTable()` method, the compiler would inform you that the `DataTable` type provides a *query pattern implementation*. Similar to the process of applying LINQ queries to objects that do not implement `IEnumerable<T>`, ADO.NET objects must be transformed into a compatible type. Understanding how to do so requires examining the types of `System.Data.DataSetExtensions.dll`.

The Role of the DataSet Extensions Library

The `System.Data.DataSetExtensions.dll` assembly, which is referenced by default in all Visual Studio projects, augments the `System.Data` namespace with a handful of new types (see Figure 22-28).

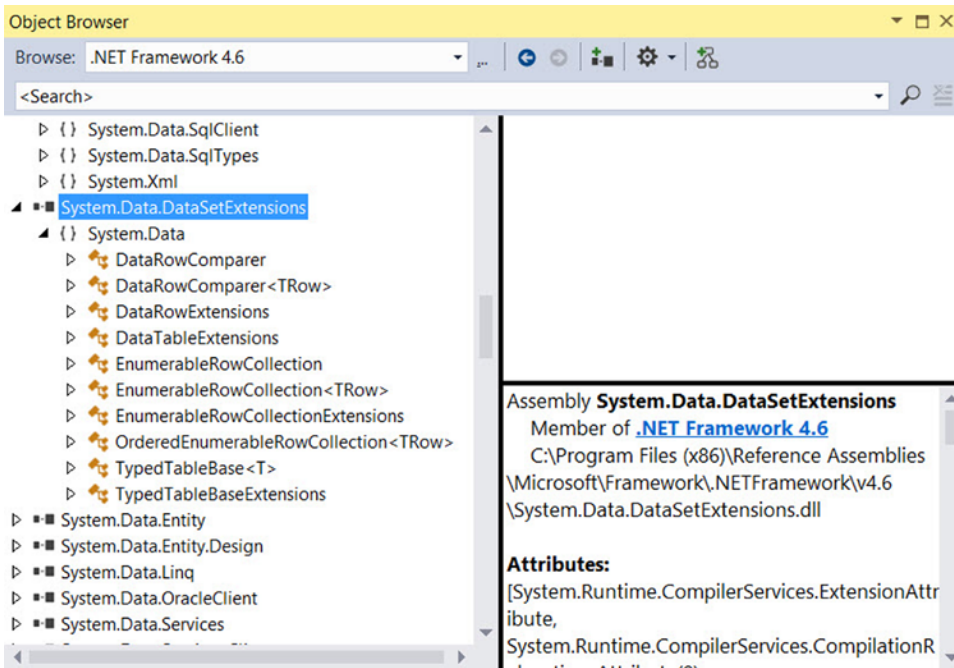

Figure 22-28. The *System.Data.DataSetExtensions.dll* assembly

The two most useful types by far are *DataTableExtensions* and *DataRowExtensions*. These classes extend the functionality of *DataTable* and *DataRow* by using a set of extension methods (see Chapter 12). The other key class is *TypedTableBaseExtensions*, which defines extension methods that you can apply to strongly typed *DataSet* objects to make the internal *DataTable* objects LINQ aware. All of the remaining members within the *System.Data.DataSetExtensions.dll* assembly are pure infrastructure, and they are not intended to be used directly in your code base.

Obtaining a LINQ-Compatible DataTable

Now let's look at how you use the *DataSet* extensions. Assume you have a new C# Console Application project named *LinqToDataSetApp*. Add a reference to the latest-and-greatest version (3.0.0.0) of the *AutoLotDAL.dll* assembly and update your initial code file with the following logic:

```
using System;
...

// Location of strongly typed data containers.
using AutoLotDAL3.DataSets;

// Location of strongly typed data adapters.
using AutoLotDAL3.DataSets.AutoLotDataSetTableAdapters;
using static System.Console;
```

```

namespace LinqToDataSetApp
{
    class Program
    {
        static void Main(string[] args)
        {
            WriteLine("***** LINQ over DataSet *****\n");

            // Get a strongly typed DataTable containing the current Inventory
            // of the AutoLot database.
            AutoLotDataSet dal = new AutoLotDataSet();
            InventoryTableAdapter tableAdapter = new InventoryTableAdapter();
            AutoLotDataSet.InventoryDataTable data = tableAdapter.GetData();

            // Invoke the methods that follow here!
            ReadLine();
        }
    }
}

```

When you want to transform an ADO.NET `DataTable` (including a strongly typed `DataTable`) into a LINQ-compatible object, you must call the `AsEnumerable()` extension method defined by the `DataTableExtensions` type. This returns an `EnumerableRowCollection` object that contains a collection of `DataRow`s.

You can then use the `EnumerableRowCollection` type to operate on each row using basic `DataRow` syntax (e.g., indexer syntax). Consider the following new method of your `Program` class, which takes a strongly typed `DataTable`, obtains an enumerable copy of the data, and prints out each `CarID` value:

```

static void PrintAllCarIDs(DataTable data)
{
    // Get enumerable version of DataTable.
    EnumerableRowCollection enumData = data.AsEnumerable();

    // Print the car ID values.
    foreach (DataRow r in enumData)
    {
        WriteLine($"Car ID = {r["CarID"]}");
    }
}

```

At this point, you have not applied a LINQ query; however, the point here is that the `enumData` object can now be the target of a LINQ query expression. Again, notice that the `EnumerableRowCollection` contains a collection of `DataRow` objects because you are applying a type indexer against each subobject to print out the value of the `CarID` column.

In most cases, you do not need to declare a variable of type `EnumerableRowCollection` to hold the return value of `AsEnumerable()`. Rather, you can invoke this method from within the query expression itself. Here is a more interesting method of the `Program` class, which obtains a projection of `CarID + Makes` from all entries in the `DataTable` where the color is black (if you don't have any black autos in your `Inventory` table, you update this LINQ query as necessary):

```
static void ShowRedCars(DataTable data)
{
    // Project a new result set containing
    // the ID/color for rows where Color = Red.
    var cars = from car in data.AsEnumerable()
               where
                   (string)car["Color"] == "Black"
               select new
               {
                   ID = (int)car["CarID"],
                   Make = (string)car["Make"]
               };
    WriteLine("Here are the red cars we have in stock:");
    foreach (var item in cars)
    {
        WriteLine($"-> CarID = {item.ID} is {item.Make}");
    }
}
```

The Role of the `DataRowExtensions.Field<T>()` Extension Method

One undesirable aspect of the current LINQ query expression is that you use numerous casting operations and `DataRow` indexers to gather the result set, which could result in runtime exceptions if you attempt to cast to an incompatible data type. To inject some strong typing into your query, you can use the `Field<T>()` extension method of the `DataRow` type. Doing so lets you increase the type safety of your query because the compatibility of data types is checked at compile time. Consider the following update:

```
var cars = from car in data.AsEnumerable()
           where
               car.Field<string>("Color") == "Black"
           select new
           {
               ID = car.Field<int>("CarID"),
               Make = car.Field<string>("Make")
           };
```

In this case, you can invoke `Field<T>()` and specify a type parameter to represent the underlying data type of the column. As an argument to this method, you pass in the column name itself. Given the additional compile-time checking, you should consider it a best practice to use `Field<T>()` (rather than the `DataRow` indexer) when you process the roles of a `EnumerableRowCollection`.

Beyond the fact that you call the `AsEnumerable()` method, the overall format of the LINQ query is identical to what you already saw in Chapter 13. Given this, there is no reason to repeat the details of the various LINQ operators here. If you would like to see additional examples, you can look up the topic “LINQ to DataSet Examples” in the .NET Framework 4.5 SDK documentation.

Hydrating New DataTables from LINQ Queries

It is also possible to populate the data of a new `DataTable` easily, based on the results of a LINQ query and provided that you are *not* using projections. When you have a result set where the underlying type can be represented as `IEnumerable<T>`, you can call the `CopyToDataTable<T>()` extension method on the result, as in this example:

```
static void BuildDataTableFromQuery(DataTable data)
{
    var cars = from car in data.AsEnumerable()
               where car.Field<int>("CarID") > 5
               select car;
    // Use this result set to build a new DataTable.
    DataTable newTable = cars.CopyToDataTable();

    // Print the DataTable.
    for (int curRow = 0; curRow < newTable.Rows.Count; curRow++)
    {
        for (int curCol = 0; curCol < newTable.Columns.Count; curCol++)
        {
            Write(newTable.Rows[curRow][curCol].ToString().Trim() + "\t");
        }
        WriteLine();
    }
}
```

■ **Note** It is also possible to transform a LINQ query to a `DataRowView` type by using the `AsDataRowView<T>()` extension method.

You might find this technique helpful when you want to use the result of a LINQ query as the source of a data-binding operation. Recall that the `DataGridView` of Windows Forms (as well as an ASP.NET or WPF grid control) supports a property named `DataSource`. You could bind a LINQ result to the grid as follows:

```
// Assume myDataGrid is a GUI-based grid object.
myDataGrid.DataSource = (from car in data.AsEnumerable()
                          where car.Field<int>("CarID") > 5
                          select car).CopyToDataTable();
```

This wraps up the examination of the disconnected layer of ADO.NET. Using this aspect of the API, you can fetch data from a relational database, munch on the data, and return it for processing while keeping the database connection open for the shortest possible amount of time.

■ **Source Code** You can find the `LinqToDataSetApp` example in the [Chapter 22](#) subdirectory.

Summary

This chapter dove into the details of the disconnected layer of ADO.NET. As you saw, the centerpiece of the disconnected layer is the `DataSet`. This type is an in-memory representation of any number of tables and any number of optional interrelationships, constraints, and expressions. The beauty of establishing relations on your local tables is that you can programmatically navigate between them while disconnected from the remote data store.

You also examined the role of the data adapter type in this chapter. Using this type (and the related `SelectCommand`, `InsertCommand`, `UpdateCommand`, and `DeleteCommand` properties), the adapter can resolve changes in the `DataSet` with the original data store. You also learned how to navigate the object model of a `DataSet` using the brute-force manual approach, as well as with strongly typed objects, which the Dataset Designer tools of Visual Studio typically generate.

You wrapped up by looking at one aspect of the LINQ technology set named LINQ to `DataSet`. This allows you to obtain a queryable copy of the `DataSet`, which can receive well-formatted LINQ queries.

CHAPTER 23



ADO.NET Part III: Entity Framework

The previous two chapters examined the fundamental ADO.NET programming models—the connected and disconnected layers, specifically. These approaches have enabled .NET programmers to work with relational data (in a relatively straightforward manner) since the initial release of the platform. However, Microsoft introduced a new component of the ADO.NET API called the *Entity Framework* (or simply, *EF*) in .NET 3.5 Service Pack 1.

■ **Note** While this first version was widely criticized, the EF team at Microsoft has been hard at work releasing new versions. Visual Studio 2015 currently (at the time of this writing) ships with version 6.1.3, which is packed full of features and performance enhancements over earlier versions. Entity Framework 7 is still in the early beta stages (again, at the time of this writing). I made the decision to focus on EF 6.x for this book since there are too many issues with EF 7.

The overarching goal of EF is to allow you to interact with data from relational databases using an object model that maps directly to the business objects (or domain objects) in your application. For example, rather than treating a batch of data as a collection of rows and columns, you can operate on a collection of strongly typed objects termed *entities*. These entities are also natively LINQ aware, and you can query against them using the same LINQ grammar you learned about in Chapter 12. The EF runtime engine translates your LINQ queries into proper SQL queries on your behalf.

This chapter will introduce you to data access using the Entity Framework. You will learn about creating a domain model, mapping model classes to the database, and the role of the `DbContext` class. You will also learn about navigation properties, transactions, and concurrency checking.

By the time you complete this chapter, you will have the final version of `AutoLotDAL.dll`. You will use this version of `AutoLotDAL.dll` later in this book when you learn about Windows Presentation Foundation (WPF), ASP.NET WebForms, and ASP.NET MVC.

■ **Note** All the versions of the Entity Framework (up to and including EF 6.x) support using an entity designer to create an entity data model XML (EDMX) file. Starting with version 4.1, EF added support for plain old CLR objects (POCO) using a technique referred to as Code First. EF 7 will support only the Code First paradigm, dropping all designer support. For this reason, this chapter will focus on Code First.

Understanding the Role of the Entity Framework

The connected and disconnected layers of ADO.NET discussed in Chapters 21 and 22 provide you with a fabric that lets you select, insert, update, and delete data with connections, commands, data readers, data adapters, and DataSet objects. While this is all well and good, these aspects of ADO.NET force you to treat the fetched data in a manner that is tightly coupled to the physical database schema. Recall, for example, that when you use the connected layer, you typically iterate over each record by specifying column names to a data reader. On the other hand, if you opt to use the disconnected layer, you find yourself traversing the rows and columns collections of a DataTable object within a DataSet container.

If you use the disconnected layer in conjunction with strongly typed DataSets/data adapters, you end up with a programming abstraction that provides some helpful benefits. First, the strongly typed DataSet class exposes a table data using class properties. Second, the strongly typed table adapter supports methods that encapsulate the construction of the underlying SQL statements. Recall the following AddRecords() method from Chapter 22:

```
public static void AddRecords(AutoLotDataSet.InventoryDataTable table,
                             InventoryTableAdapter adapter)
{
    // Get a new strongly typed row from the table.
    AutoLotDataSet.InventoryRow newRow = table.NewInventoryRow();

    // Fill row with some sample data.
    newRow.Color = "Purple";
    newRow.Make = "BMW";
    newRow.PetName = "Saku";

    // Insert the new row.
    table.AddInventoryRow(newRow);

    // Add one more row, using overloaded Add method.
    table .AddInventoryRow("Yugo", "Green", "Zippy");

    // Update database.
    adapter.Update(table);
}
```

Things got even better when you combined the disconnected layer with LINQ to DataSet. In the example, you applied LINQ queries to your in-memory data to obtain a new result set. You could then optionally map to a stand-alone object such as a new DataTable, a List<T>, a Dictionary<K,V>, or an array of data, as follows:

```
static void BuildDataTableFromQuery(DataTable data)
{
    var cars = from car in data.AsEnumerable()
               where car.Field<int>("CarID") > 5 select car;

    // Use this result set to build a new DataTable.
    DataTable newTable = cars.CopyToDataTable();

    // Work with DataTable...
}
```

While LINQ to DataSet is useful, you need to remember that the target of your LINQ query is the *data returned from the database*, not the database engine itself. This means you are pulling all the data from the database into the client and *then* using LINQ to get a subset or transform the data. Ideally, you could build a LINQ query that you send directly to the database engine for processing and get some strongly typed data in return (which is exactly what the ADO.NET Entity Framework lets you accomplish).

When you use either the connected or disconnected layer of ADO.NET, you must always be mindful of the physical structure of the back-end database. You must know the schema of each data table, author potentially complex SQL queries to interact with said data table, and so forth. This can force you to author some fairly verbose C# code because C# itself does not speak the language of database schema directly.

To make matters worse, the way in which a physical database is constructed (by your friendly DBA) is squarely focused on database constructs such as foreign keys, views, and stored procedures. The databases constructed by your friendly DBA can grow quite complex as the DBA endeavors to account for security and scalability. This also complicates the sort of C# code you must author to interact with the data store.

The ADO.NET Entity Framework (EF) is a programming model that attempts to lessen the gap between database constructs and object-oriented programming constructs. Using EF, you can interact with a relational database without ever seeing a line of SQL code (if you so choose). Rather, when you apply LINQ queries to your strongly typed classes, the EF runtime generates proper SQL statements on your behalf.

■ **Note** *LINQ to Entities* is the term that describes the act of applying LINQ queries to ADO.NET EF entity objects.

Another possible approach (rather than updating database data by finding a row, updating the row, and sending the row back for processing with a batch of SQL queries), you can simply change properties on an object and save its state. Again, the EF runtime updates the database automatically.

As far as Microsoft is concerned, the ADO.NET Entity Framework is simply another approach to the data-access APIs and is not intended to completely replace using ADO.NET directly from C# code. However, once you spend some time working with EF, you might quickly find yourself preferring this rich object model over the more primitive world of SQL queries and row/column collections.

Nevertheless, chances are you will find uses for all three approaches in your .NET projects; in some cases, the EF model might complicate your code base. For example, if you want to build an in-house application that needs to communicate with only a single database table, you might prefer to use the connected layer to call a batch of related stored procedures. Larger applications can particularly benefit from EF, especially if the development team is comfortable working with LINQ. As with any new technology, you will need to determine how (and when) ADO.NET EF is appropriate for the task at hand.

■ **Note** You might recall a database programming API introduced with .NET 3.5 called LINQ to SQL. This API is close in concept (and fairly close in terms of programming constructs) to ADO.NET EF. LINQ to SQL is in maintenance mode, meaning it will receive only critical bug fixes. If you have an application using LINQ to SQL, know that Microsoft's official policy is to support all software for at least ten years after its "end of life." So while it won't be removed from your machine by the software guardians, the official word from those kind folks in Redmond is that you should put your efforts into EF, not LINQ to SQL. They certainly are.

The Role of Entities

The strongly typed classes mentioned previously are called *entities*. Entities are a conceptual model of a physical database that maps to your business domain. Formally speaking, this model is termed an *entity data model (EDM)*. The EDM is a client-side set of classes that are mapped to a physical database by Entity Framework convention and configuration. You should understand that the entities need not map directly to the database schema insofar as naming conventions go. You are free to restructure your entity classes to fit your needs, and the EF runtime will map your unique names to the correct database schema.

■ **Note** In the Code First world, most people refer to the POCO classes as *models* and the collection of these classes as the *model*. When the model classes are instantiated with data from the data store, they are then referred to as *entities*. In reality, the terms are pretty much used interchangeably.

For example, you might recall that you created the simple Inventory table in the AutoLot database using the database schema shown in Figure 23-1.

| Name | Data Type | Allow Nulls | Default |
|---------|--------------|-------------------------------------|---------|
| CarId | int | <input type="checkbox"/> | |
| Make | nvarchar(50) | <input checked="" type="checkbox"/> | |
| Color | nvarchar(50) | <input checked="" type="checkbox"/> | |
| PetName | nvarchar(50) | <input checked="" type="checkbox"/> | |
| | | <input type="checkbox"/> | |

Figure 23-1. Structure of the Inventory table of the AutoLot database

If you were to create the model for the Inventory table of the AutoLot database (you'll see how to do so momentarily), the class would be called Inventory by default. However, you could rename this class to Car and define uniquely named properties of your choosing, which will be mapped to the columns of the Inventory table. This loose coupling means you can shape the entities so they closely model your business domain. Figure 23-2 shows such an entity class.

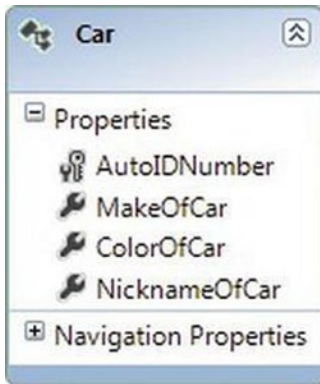

Figure 23-2. The Car model is a client-side reshaping of the Inventory schema

■ **Note** In many cases, the model classes will be identically named to the related database tables. However, remember that you can always reshape the model to match your business situation.

You will build a full example with EF in just a bit. However, for the time being, consider the following Program class, which uses the Car model class (and a related context class named `AutoLotEntities`) to add a new row to the Inventory table of AutoLot. The `AutoLotEntities` context class derives from `DbContext`. The job of this class is to communicate with the physical database on your behalf (you will learn more details soon).

```
class Program
{
    static void Main(string[] args)
    {
        // Connection string automatically read from config file.
        using (AutoLotEntities context = new AutoLotEntities())
        {
            // Add a new record to Inventory table, using our model.
            context.Cars.Add(new Car() { ColorOfCar = "Black",
                                        MakeOfCar = "Pinto",
                                        NicknameOfCar = "Pete" });

            context.SaveChanges();
        }
    }
}
```

It is up to the EF runtime to take the client-side representation of the Inventory table (here, a class named `Car`) and map it back to the correct columns of the Inventory table. Notice that you see no trace of any sort of SQL INSERT statement. You simply add a new `Car` object to the collection maintained by the aptly named `Cars` property of the context object and save your changes. Sure enough, if you view the table data using the Server Explorer of Visual Studio, you will see a new record (see Figure 23-3).

| | CarId | Make | Color | PetName |
|-----|-------|--------|---------|---------|
| ▶ 1 | VW | Black | Zippy | |
| 2 | Ford | Rust | Rusty | |
| 3 | Saab | Black | Mel | |
| 4 | Yugo | Yellow | Clunker | |
| 5 | BMW | Black | Bimmer | |
| 6 | BMW | Green | Hank | |
| 7 | BMW | Pink | Pinky | |
| 13 | Pinto | Black | Pete | |
| 55 | Yugo | Brown | Brownie | |
| * | NULL | NULL | NULL | NULL |

Figure 23-3. The result of saving the context

There is no magic in the preceding example. Under the covers, a connection to the database is made, a proper SQL statement is generated, and so forth. The benefit of EF is that these details are handled on your behalf. Now let's look at the core services of EF that make this possible.

The Building Blocks of the Entity Framework

The EF API sits on top of the existing ADO.NET infrastructure you have already examined in the previous two chapters. Like any ADO.NET interaction, the Entity Framework uses an ADO.NET data provider to communicate with the data store. However, the data provider must be updated so it supports a new set of services before it can interact with the EF API. As you might expect, the Microsoft SQL Server data provider has been updated with the necessary infrastructure, which is accounted for when using the `System.Data.Entity.dll` assembly.

■ **Note** Many third-party databases (e.g., Oracle and MySQL) provide EF-aware data providers. Consult your database vendor for details or log on to <https://msdn.microsoft.com/en-us/library/dd363565.aspx> for a list of known ADO.NET data providers. EF builds on top of the ADO.NET data provider model and will work with any datasource where a data provider is available.

In addition to adding the necessary bits to the Microsoft SQL Server data provider, the `System.Data.Entity.dll` assembly contains various namespaces that account for the EF services themselves. The two key pieces of the EF API to concentrate on (for the time being) are the `DbContext` class and the derived model-specific context.

The Role of the DbContext Class

The DbContext class represents a combination of the Unit of Work and Repository patterns that can be used to query from a database and group together changes that will be written back as a single unit of work. DbContext provides a number of core services to child classes, including the ability to save all changes (which results in a database update), tweak the connection string, delete objects, call stored procedures, and handle other fundamental details. Table 23-1 shows some of the more commonly used members of the DbContext.

Table 23-1. Common Members of DbContext

| Member of DbContext | Meaning in Life |
|---------------------------------|--|
| DbContext | Constructor used by default in the derived context class. The string parameter is either the database name or the connection string stored in the *.config file. |
| Entry Entry<TEntity> | Retrieves the System.Data.Entity.Infrastructure.DbEntityEntry object providing access to information and the ability to perform actions on the entity. |
| GetValidationErrors | Validates tracked entries and returns a collection of System.Data.Entity.Validation.DbEntityValidationResults. |
| SaveChanges SaveChangesAsync | Saves all changes made in this context to the database. Returns the number of affected entities. |
| Configuration | Provides access to the configuration properties of the context. |
| Database | Provides a mechanism for creation/deletion/existence checks for the underlying database, executes stored procedures and raw SQL statements against the underlying data store, and exposes transaction functionality. |

DbContext also implements IObjectContextAdapter, so any of the functionality available in theObjectContext class is also available. While DbContext takes care of most of your needs, there are two events that can be extremely helpful, as you will see later in the chapter. Table 23-2 lists the events.

Table 23-2. Events in DbContext

| Events of DbContext | Meaning in Life |
|---------------------|--|
| ObjectMaterialized | Fires when a new entity object is created from the data store as part of a query or load operation |
| SavingChanges | Occurs when changes are being saved to the data store but prior to the data being persisted |

The Role of the Derived Context Class

As mentioned, the `DbContext` class provides the core functionality when working with EF Code First. In your projects, you will create a class that derives from `DbContext` for your specific domain. In the constructor, you need to pass the name of the connection string for this context class to the base class, as shown here:

```
public class AutoLotEntities : DbContext
{
    public AutoLotEntities() base("name=AutoLotConnection")
    {
    }
    protected override void Dispose(bool disposing)
    {
    }
}
```

The Role of `DbSet<T>`

To add tables into your context, you add a `DbSet<T>` for each table in your object model. To enable lazy loading, the properties in the context need to be virtual, like this:

```
public virtual DbSet<CreditRisk> CreditRisks { get; set; }
public virtual DbSet<Customer> Customers { get; set; }
public virtual DbSet<Inventory> Inventory { get; set; }
public virtual DbSet<Order> Orders { get; set; }
```

Each `DbSet<T>` provides a number of core services to each collection, such as creating, deleting, and finding records in the represented table. Table 23-3 describes some of the core members of the `DbSet<T>` class.

Table 23-3. Common Members of `DbSet<T>`

| Member of <code>DbSet<T></code> | Meaning in Life |
|---------------------------------------|---|
| Add | Allows you to insert a new object (or range of objects) into the collection. |
| AddRange | They will be marked with the Added state and will be inserted into the database when <code>SaveChanges</code> (or <code>SaveChangesAsync</code>) is called on the <code>DbContext</code> . |
| Attach | Associates an object with the <code>DbContext</code> . This is commonly used in disconnected applications like ASP.NET/MVC. |
| Create | Creates a new instance of the specified entity type. |
| Create<T> | |
| Find | Finds a data row by the primary key and returns an object representing that row. |
| FindAsync | |
| Remove | Marks an object (or range of objects) for deletion. |
| RemoveRange | |
| SqlQuery | Creates a raw SQL query that will return entities in this set. |

Once you drill into the correct property of the object context, you can call any member of `DbSet<T>`. Consider again the sample code shown in the first few pages of this chapter:

```
using (AutoLotEntities context = new AutoLotEntities())
{
    // Add a new record to Inventory table, using our entity.
    context.Cars.Add(new Car() { ColorOfCar = "Black",
                                MakeOfCar = "Pinto",
                                NicknameOfCar = "Pete" });

    context.SaveChanges();
}
```

Here, `AutoLotEntities` is a derived `Context`. The `Cars` property gives you access to the `DbSet<Car>` variable. You use this reference to insert a new `Car` entity object and tell the `DbContext` to save all changes to the database.

`DbSet<T>` is typically the target of LINQ to Entity queries; as such, `DbSet<T>` supports the same extension methods you learned about in Chapter 12, such as `ForEach()`, `Select()`, and `All()`. Moreover, `DbSet<T>` gains a good deal of functionality from its direct parent class, `DbQuery<T>`, which is a class that represents a strongly typed LINQ (or Entity SQL) query.

Empty Code First Model or Code First from Database

Before you build your first Entity Framework example, there's one more point to discuss. You can build an Entity Framework data model from scratch or reverse engineer it from an existing database (just as you can using the Entity Framework Designer). You will examine both of these methods in the following sections.

Transaction Support

All versions of EF wrap each call to `SaveChanges/SaveChangesAsync` in a transaction. The isolation level of these automatic transactions is the same as the default isolation level for the database (which is `READ COMMITTED` for SQL Server). You can add more control to the transactional support in EF if you need it. For more information, see <https://msdn.microsoft.com/en-us/data/dn456843.aspx>.

■ **Note** Although not covered in this book, executing SQL statements using `ExecuteSqlCommand()` from the `DbContext` database object is now wrapped in an implicit transaction. This is new in EF version 6.

Entity State

The `DbContext` automatically tracks the state for any object within its context. In the previous examples, while inside the `using` statement, any changes to the data will be tracked and saved when `SaveChanges` is called on the `AutoLotEntities` class. Table 23-4 lists the possible values for the state of an object.

Table 23-4. *Entity State Enumeration Values*

| Value | Meaning in Life |
|-----------|--|
| Detached | The object exists but is not being tracked. An entity is in this state immediately after it has been created and before it is added to the object context. |
| Unchanged | The object has not been modified since it was attached to the context or since the last time that the <code>SaveChanges()</code> method was called. |
| Added | The object is new and has been added to the object context, and the <code>SaveChanges()</code> method has not been called. |
| Deleted | The object has been deleted from the object context but not yet removed from the data store. |
| Modified | One of the scalar properties on the object was modified, and the <code>SaveChanges()</code> method has not been called. |

If you need to check the state of an object, use the following code:

```
EntityState state = context.Entry(entity).State;
```

You usually don't need to worry about the state of your objects. However, in the case of deleting an object, you can set the state of an object to `EntityState.Deleted` and save a round-trip to the database. You will do this later in the chapter.

Code First from an Existing Database

Now that you have a better understanding of what the ADO.NET Entity Framework is and how it works from a high level, it's time to look at your first full example. You will build a simple console app that uses Code First from an existing database to create the model classes representing the existing `AutoLot` database you built in Chapters 21 and 22. You will write code in the console app that performs typical create, read, update, and delete (CRUD) operations, and then you will look at everything that was built for you.

Generating the Model

Begin by creating a new Console Application project named `AutoLotConsoleApp`. Add a folder to the project through the Project ► New Folder menu option and name it `EF`. Select the new `EF` folder and then select Project ► Add New Item (be sure to highlight the Data node) to insert a new ADO.NET Entity Data Model item named `AutoLotEntities` (as in Figure 23-4).

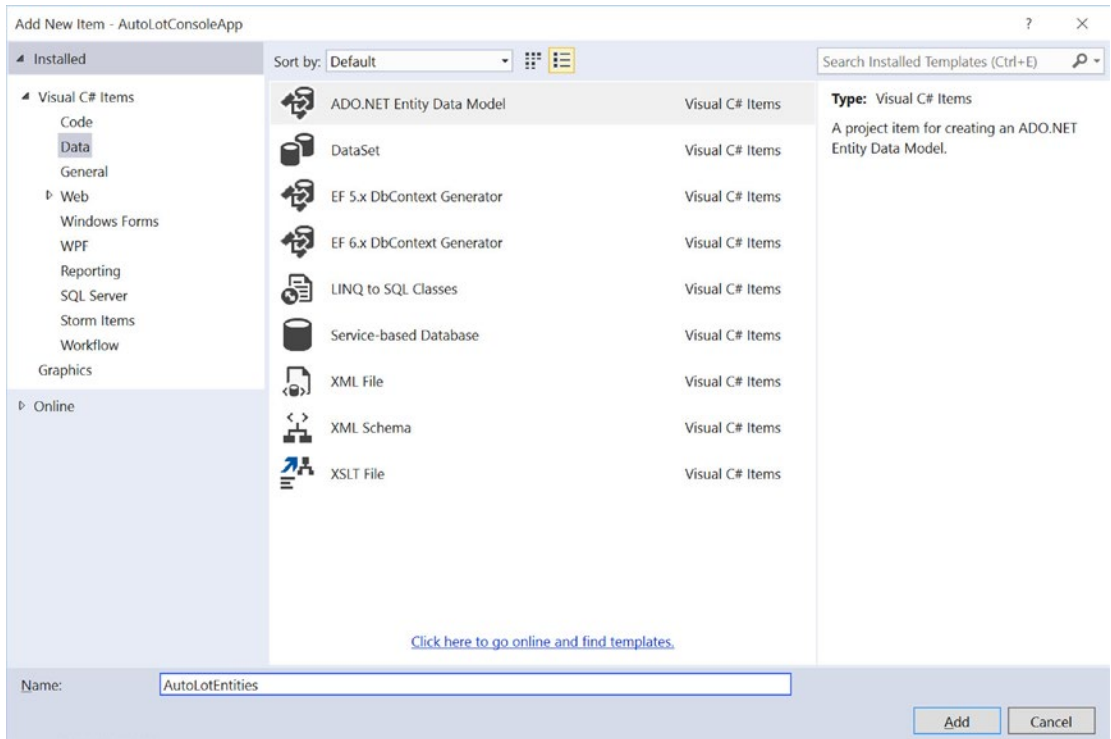

Figure 23-4. Inserting a new ADO.NET EDM project item

Clicking the Add button launches the Entity Model Data Wizard. The wizard's first step allows you to select the option to generate an EDM using the Entity Framework Designer (from an existing database or by creating an empty designer) or using Code First (from an existing database or by creating an empty DbContext). Select the "Code First from database" option and click the Next button (see Figure 23-5).

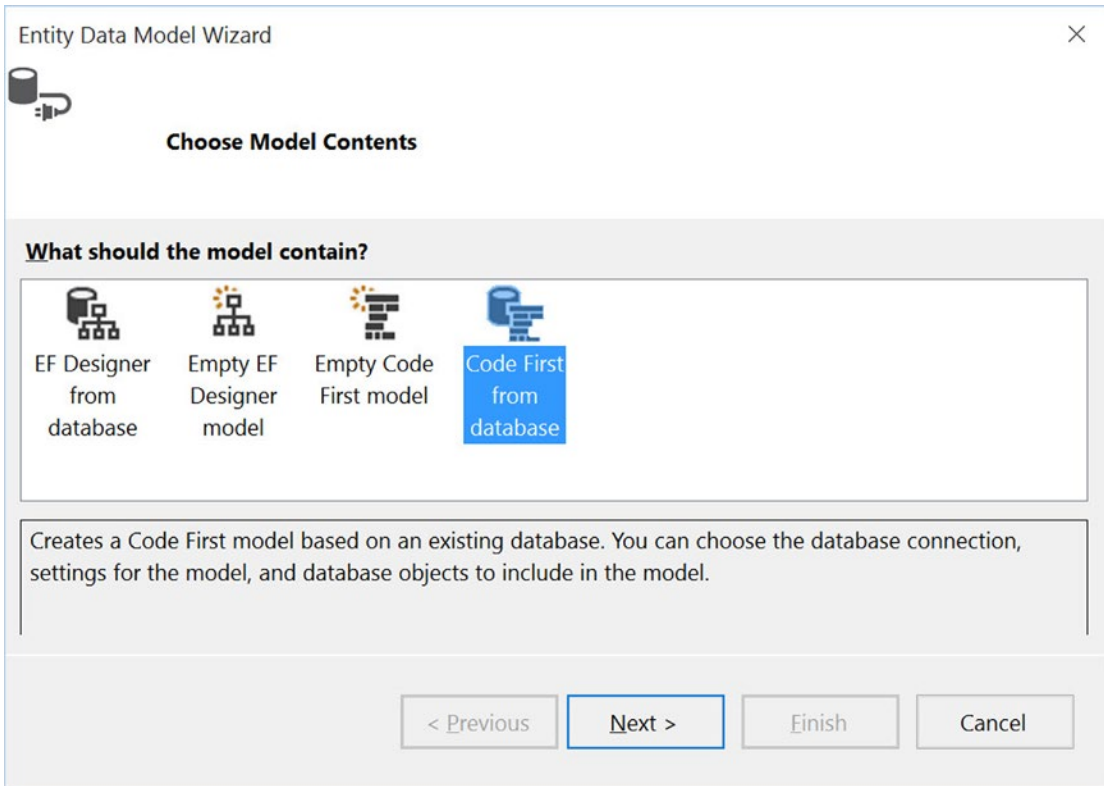

Figure 23-5. Generating an EDM from an existing database

You can select your database in the wizard's second step. If you already have a connection to a database within the Visual Studio Server Explorer, you will see it listed in the drop-down combo box. If this is not the case, you can click the New Connection button. Either way, pick your AutoLot database and then make certain you save the connection string data in the (autogenerated) App.config file (see Figure 23-6), changing the name to AutoLotConnection.

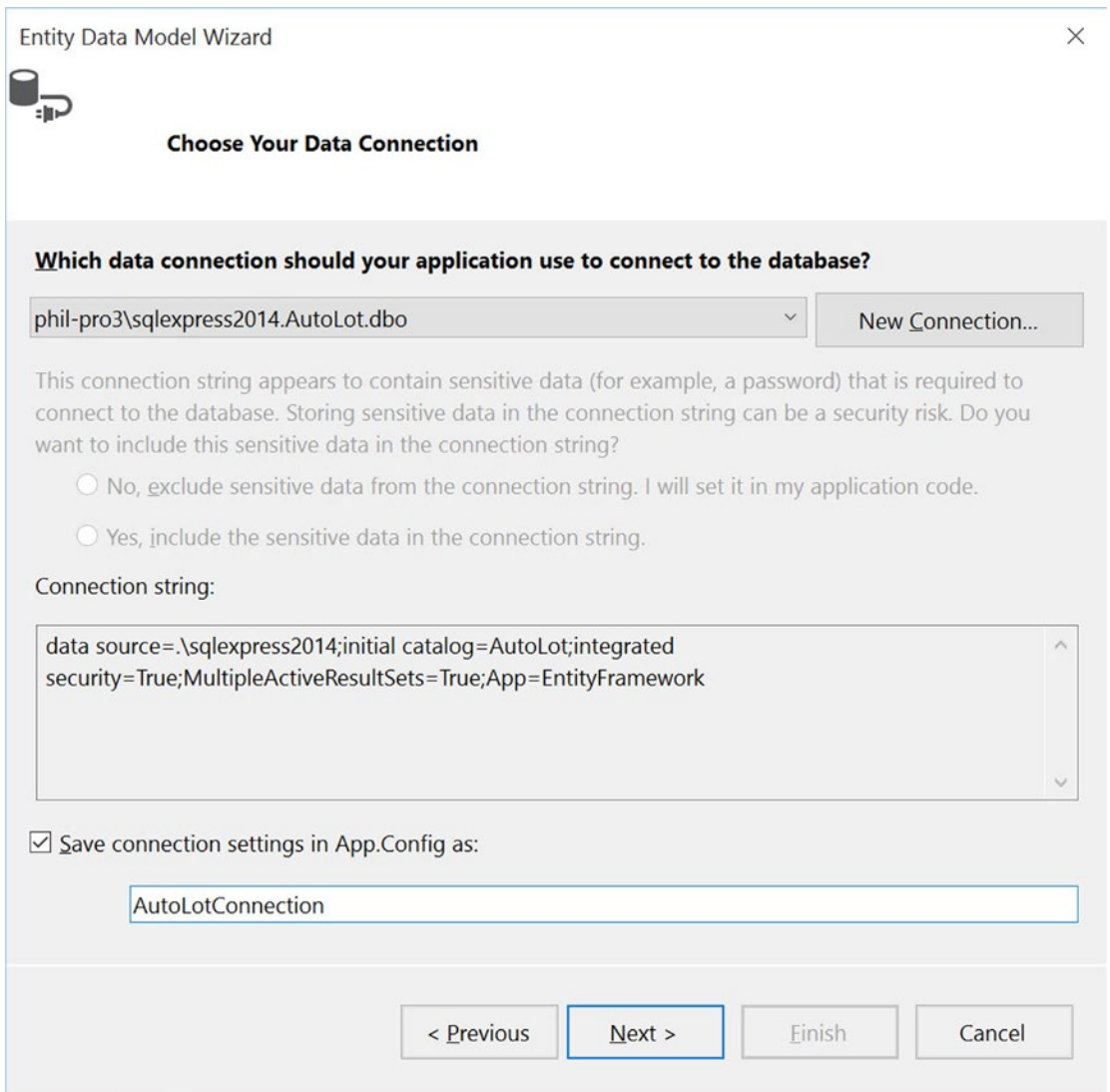

Figure 23-6. Selecting the database used to generate the model

Before you click the Next button, take a moment to examine the format of your connection string.

```
Data source= .\SQLEXPRESS2014;Initial Catalog=AutoLot;Integrated
Security=True;MultipleActiveResultSets=true;App=EntityFramework
```

This is extremely similar to what you used in Chapters 21 and 22, with the addition of the `App=EntityFramework` name-value pair. `App` is short for application name, which can be used when troubleshooting SQL Server issues.

In the wizard's final step, you can select the items from the database you want to use to generate the EDM. Select all the application tables, making sure you don't select `sysdiagrams` (if it exists in your database). The dialog will look something like Figure 23-7.

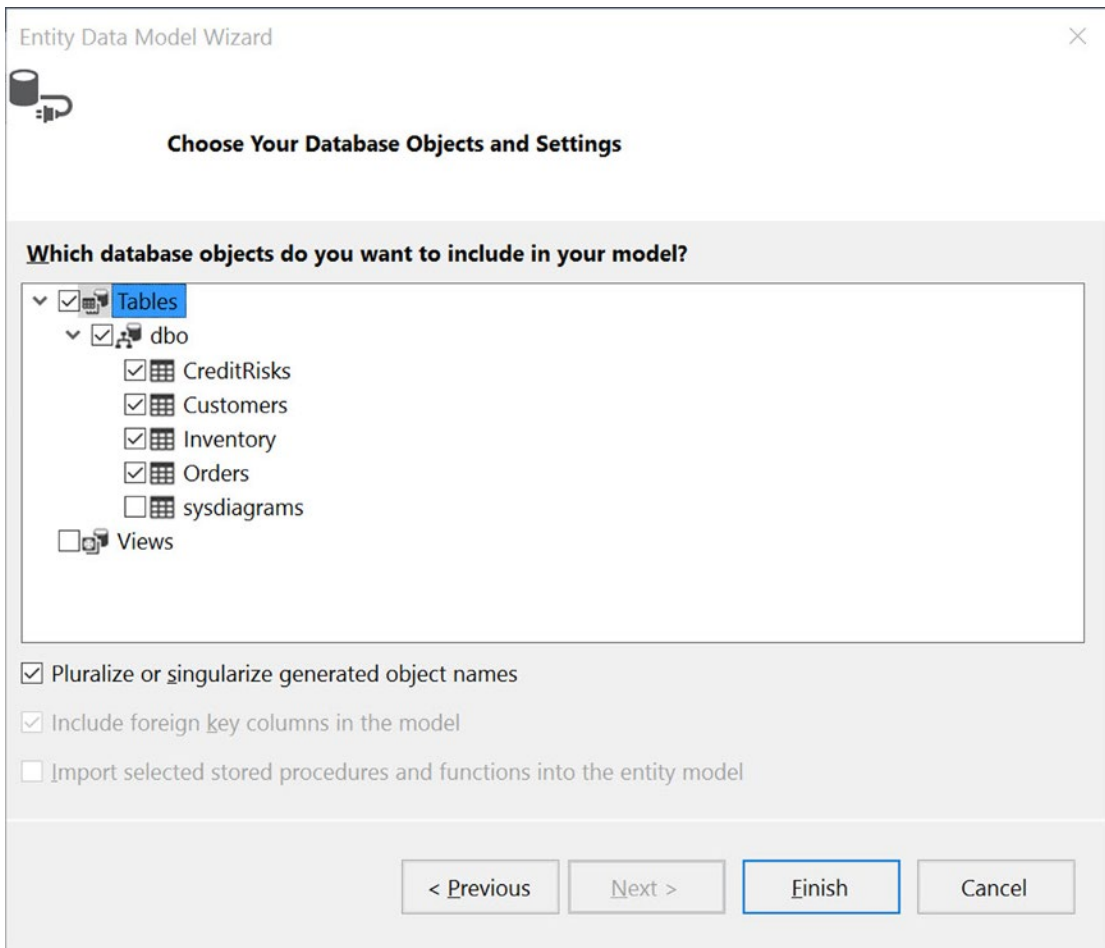

Figure 23-7. Selecting the database items

Now, click the Finish button to generate your EDM data.

What Did That Do?

After you complete the wizard, you will see several new classes in your project: one for each table that you selected in the wizard and another one named `AutoLotEntities` (the same name that you entered in the first step of the wizard). By default, the names of your entities will be based on the original database object names; however, recall that the names of entities in your conceptual model can be anything you choose. You can change the entity name, as well as property names of the entity, by using special .NET attributes referred to as *data annotations*. You will use data annotations to make some modifications to your model.

■ **Note** The Fluent API is another way to configure your model classes and properties to map them to the database. Everything you can do with data annotations, you can also do with code through the Fluent API. Because of space and time constraints, I focus on covering data annotations in this chapter with only a brief mention of the Fluent API.

Open the `Inventory` class. The first thing you will notice is a series of attributes decorating the class and properties in the class. These are called *data annotations*, and they instruct EF how to build your tables and properties when generating the database. They also instruct EF how to map the data from the database to your model classes. At the class level, the `Table` attribute specifies what table the class maps to. At the property level, there are two attributes in use. The first you see is the `Key` attribute. This specifies the primary key for the table. The other attribute in use is `StringLength`, which specifies the string length when generating the DDL for the field. This attribute is also used in validations, as you will see in later chapters.

■ **Note** There are also two `SuppressMessage` attributes. This instructs static analyzers such as `FXCop` and the new Roslyn code analyzers to turn off the specific rules listed in the constructor.

```
[Table("Inventory")]
public partial class Inventory
{
    [System.Diagnostics.CodeAnalysis.SuppressMessage("Microsoft.Usage",
        "CA2214:DoNotCallOverridableMethodsInConstructors")]
    public Inventory()
    {
        Orders = new HashSet<Order>();
    }

    [Key]
    public int CarId { get; set; }

    [StringLength(50)]
    public string Make { get; set; }

    [StringLength(50)]
    public string Color { get; set; }

    [StringLength(50)]
    public string PetName { get; set; }

    [System.Diagnostics.CodeAnalysis.SuppressMessage("Microsoft.Usage",
        "CA2227:CollectionPropertiesShouldBeReadOnly")]
    public virtual ICollection<Order> Orders { get; set; }
}
```

You can also see that the `Inventory` class has a collection of `Order` objects. This specifies a one-to-many relationship between `Inventory` and `Order`. At the other end of the relationship, the `Order` class specifies a `CarId` property and a `Car` property.

```

public partial class Order
{
    public int OrderId { get; set; }

    public int CustId { get; set; }

    public int CarId { get; set; }

    public virtual Customer Customer { get; set; }

    public virtual Inventory Inventory { get; set; }
}

```

Next, open the `AutoLotEntities` class. This class derives from `DbContext` and contains a `DbSet<TEntity>` property for each table that you specified in the wizard. It also overrides `OnModelCreating()` to use the `FluentAPI` to define the relationships between `Customer` and `Orders` and between `Orders` and `Inventory`.

```

public partial class AutoLotEntities : DbContext
{
    public AutoLotEntities()
        : base("name=AutoLotConnection")
    {
    }

    public virtual DbSet<CreditRisk> CreditRisks { get; set; }
    public virtual DbSet<Customer> Customers { get; set; }
    public virtual DbSet<Inventory> Inventories { get; set; }
    public virtual DbSet<Order> Orders { get; set; }

    protected override void OnModelCreating(DbModelBuilder modelBuilder)
    {
        modelBuilder.Entity<Customer>()
            .HasMany(e => e.Orders)
            .WithRequired(e => e.Customer)
            .WillCascadeOnDelete(false);

        modelBuilder.Entity<Inventory>()
            .HasMany(e => e.Orders)
            .WithRequired(e => e.Inventory)
            .WillCascadeOnDelete(false);
    }
}

```

Finally, open the `App.config` file. You will see a new `configSection` (named `entityFramework`), as well as the connection string generated by the wizard. Most of this you can ignore, but if you change the database, know that the only thing you might need to modify is the connection string values for the `AutoLotConnection` connection string (the same name you specified in the wizard).

```

<configuration>
  <configSections>
    <!-- For more information on Entity Framework configuration, visit
    http://go.microsoft.com/fwlink/?LinkID=237468 -->
    <section name="entityFramework" type="System.Data.Entity.Internal.ConfigFile.
    EntityFrameworkSection, EntityFramework, Version=6.0.0.0, Culture=neutral,
    PublicKeyToken=b77a5c561934e089" requirePermission="false" />
  </configSections>
  <startup>
    <supportedRuntime version="v4.0" sku=".NETFramework,Version=v4.6" />
  </startup>
  <entityFramework>
    <defaultConnectionFactory type="System.Data.Entity.Infrastructure.SqlConnectionFactory,
    EntityFramework" />
    <providers>
      <provider invariantName="System.Data.SqlClient" type="System.Data.Entity.SqlServer.
      SqlProviderServices, EntityFramework.SqlServer" />
    </providers>
  </entityFramework>
  <connectionStrings>
    <add name="AutoLotConnection" connectionString="data source=.\SQLEXPRESS2014;initial
    catalog=AutoLot;integrated security=True;MultipleActiveResultSets=True;App=Entity
    Framework" providerName="System.Data.SqlClient" />
  </connectionStrings>
</configuration>

```

Changing the Default Mappings

As discussed in the previous section, the `[Table("Inventory")]` attribute specifies that the class maps to the Inventory table. With this attribute in place, you can change the name of your class to anything you want. Change the class name (and the constructor) to `Car`. In addition to the `Table` attribute, EF also uses the `Column` attribute. By adding the `[Column("PetName")]` attribute to the `PetName` property, you can change the name of the property to `CarNickName`. The relevant code should look like this:

```

[Table("Inventory")]
public partial class Car
{
    public Car()
    {
        Orders = new HashSet<Order>();
    }

    [StringLength(50), Column("PetName")]
    public string CarNickName { get; set; }

    //remainder of the class not shown for brevity
}

```

If you changed the name and didn't use the Visual Studio refactoring capabilities, your application won't compile. If it doesn't compile, open the `Order` class and change the type and name of the `Inventory` property to `Car`. The relevant code is shown here:

```
public partial class Order
{
    public virtual Car Car { get; set; }

    //remainder of the class not shown for brevity
}
```

The last change to make is to the `AutoLotEntities` class (unless you used the automatic refactorings available to you in Visual Studio 2015). Open the file and change the two occurrences of `Inventory` to `Car` and the `DbSet<Car>` to `Cars`. The updated code is shown here:

```
public partial class AutoLotEntities : DbContext
{
    public AutoLotEntities()
        : base("name=AutoLotConnection")
    {
    }

    // Additional code removed for brevity

    public virtual DbSet<Car> Cars { get; set; }

    protected override void OnModelCreating(DbModelBuilder modelBuilder)
    {
        modelBuilder.Entity<Car>()
            .HasMany(e => e.Orders)
            .WithRequired(e => e.Car)
            .WillCascadeOnDelete(false);

        // Additional code removed for brevity
    }
}
```

■ **Note** The EF team has released a set of power tools (appropriately named Entity Framework Power Tools) for Visual Studio. These tools allow various ways to diagram your EDM and additional functionality. At the time of this writing, unfortunately they are not available for Visual Studio 2015. Keep an eye on <https://visualstudiogallery.msdn.microsoft.com/72a60b14-1581-4b9b-89f2-846072eff19d/> for an update.

Adding to the Generated Model Classes

All the designer-generated classes have been declared with the `partial` keyword, which, if you recall, allows you to implement a class across multiple C# code files. This is especially useful when working with the EF programming model because it means you can add additional methods to your entity classes that help you model your business domain better.

For example, you can override the `ToString()` method of the `Car` entity class to return the state of the entity with a well-formatted string. If you add this to the generated class, you risk losing that custom code each time you regenerate your model classes. Instead, define the following partial class declaration in a new file named `CarPartial.cs`. The new class is listed here:

```
public partial class Car
{
    public override string ToString()
    {
        // Since the PetName column could be empty, supply
        // the default name of **No Name**.
        return $"{this.CarNickName ?? "**No Name**"} is a {this.Color} {this.Make} with ID
        {this.CarId}.";
    }
}
```

Using the Model Classes in Code

Now that you have your model classes, you can author some code that interacts with them and therefore the database. Begin by adding using statements for `AutoLotConsoleApp.EF` and `static System.Console` to your `Program` class.

Inserting a Record

Add a helper method from `Main()` (named `AddNewRecord()`), which will insert a new record to the `Inventory` table.

```
private static int AddNewRecord()
{
    // Add record to the Inventory table of the AutoLot
    // database.
    using (var context = new AutoLotEntities())
    {
        try
        {
            // Hard-code data for a new record, for testing.
            var car = new Car() { Make = "Yugo", Color = "Brown", CarNickName="Brownie"};
            context.Cars.Add(car);
            context.SaveChanges();
            // On a successful save, EF populates the database generated identity field.
            return car.CarId;
        }
        catch(Exception ex)
        {
            WriteLine(ex.InnerException.Message);
            return 0;
        }
    }
}
```

This code uses the `Add()` method on the `DbSet<Car>` class. The `Add()` method takes an object of type `Car` and adds it to the `Cars` collection on the `AutoLotEntities` context class. By inserting a new `Car` object with the `Add()` method of `DbSet<Car>` and then calling `SaveChanges()` on the context, you have performed a SQL INSERT. When `SaveChanges` is called, all pending changes (in this case, only the one additional record) are saved to the database. If no errors occur, then the record is added, and the `Car` object gets updated with any database-generated values, in this case, the `CarId`.

To see this in action, update the `Main()` method like this:

```
static void Main(string[] args)
{
    WriteLine("***** Fun with ADO.NET EF *****\n");
    int carId = AddNewRecord();
    WriteLine(carId);
    ReadLine();
}
```

The output to the console is indeed the `CarId` of the new record. It's important to note that while you didn't have to do anything special to get the database generated IDs, EF executed a `SELECT` statement on your behalf to get the `CarId` value. This is not a big deal in most applications, but it's important to understand in case performance or scaling issues arise and you need to start trimming calls.

Selecting Records

There are several ways to get records out of the database using EF. The simplest is to iterate over the `DbSet<Car>` collection. To see this in action, add a new method named `PrintAllInventory()`. Add a `foreach` loop for the `Cars` property of the `DbContext` (which returns a `DbSet<Car>`) and print each car, as follows:

```
private static void PrintAllInventory()
{
    // Select all items from the Inventory table of AutoLot,
    // and print out the data using our custom ToString()
    // of the Car entity class.
    using (var context = new AutoLotEntities())
    {
        foreach (Car c in context.Cars)
        {
            WriteLine(c);
        }
    }
}
```

To see this in action, update your `Main()` method as follows:

```
class Program
{
    static void Main(string[] args)
    {
        WriteLine("***** Fun with ADO.NET EF *****\n");
    }
}
```

```

    //int carId = AddNewRecord();
    //WriteLine(carId);
    PrintAllInventory();
    ReadLine();
}

```

Enumerating each item exposed by the `Cars` property submits a SQL `SELECT` statement implicitly to the underlying ADO.NET data provider. It is important to note that underneath EF is creating a `DataReader` to load the records from the database and then transforms the records from the `DataReader` into `Car` types.

Querying with SQL

EF also supports filling `DbSets` with SQL (either inline or stored procedures). To test this, update the `PrintInventory()` method to the following:

```

private static void PrintAllInventory()
{
    // Select all items from the Inventory table of AutoLot,
    // and print out the data using our custom ToString()
    // of the Car entity class.
    using (var context = new AutoLotEntities())
    {
        //foreach (Car c in context.Cars)
        //{
        //    WriteLine(c);
        //}
        foreach (Car c in context.Cars.SqlQuery("Select CarId,Make,Color,PetName as CarNickName
        from Inventory where Make=@p0", "BMW"))
        {
            WriteLine(c);
        }
    }
}

```

The good news is that this fills the list with tracked entities, which means that any changes or deletions will get propagated to the database when `SaveChanges` is called. The bad news (as you can see from the SQL text) is that `SqlQuery` doesn't understand the mapping changes that you made earlier. Not only do you have to use the database table and field names, but any field name changes (such as the change to `PetName`) must be aliased from the database field name to the model property name.

Querying with LINQ

EF becomes much more powerful when you incorporate LINQ queries. Consider this update to the `PrintInventory()` method that uses LINQ to get the records from the database:

```

private static void PrintAllInventory()
{
    // Select all items from the Inventory table of AutoLot,
    // and print out the data using our custom ToString()
    // of the Car entity class.

```

```

using (var context = new AutoLotEntities())
{
    //foreach (Car c in context.Cars)
    //{
    //    WriteLine(c);
    //}
    //foreach (Car c in context.Cars.SqlQuery("Select CarId,Make,Color,PetName as
    //    CarNickName from Inventory where Make=@p0", "BMW"))
    //{
    //    WriteLine(c);
    //}
    foreach (Car c in context.Cars.Where(c => c.Make == "BMW"))
    {
        WriteLine(c);
    }
}

```

The LINQ statement is translated into a SQL query, which creates a `DataReader`, and then returns a collection of attached `Cars`. The generated query looks something like this (it might differ slightly on your machine):

```

SELECT
    [Extent1].[CarId] AS [CarId],
    [Extent1].[Make] AS [Make],
    [Extent1].[Color] AS [Color],
    [Extent1].[PetName] AS [PetName]
FROM [dbo].[Inventory] AS [Extent1]
WHERE N'BMW' = [Extent1].[Make]

```

Given that you have already worked with many LINQ expressions in [Chapter 13](#), a few more examples will suffice for the time being.

```

private static void FunWithLinqQueries()
{
    using (var context = new AutoLotEntities())
    {
        // Get a projection of new data.
        var colorsMakes = from item in context.Cars select new { item.Color, item.Make };
        foreach (var item in colorsMakes)
        {
            WriteLine(item);
        }

        // Get only items where Color == "Black"
        var blackCars = from item in context.Cars where item.Color == "Black" select item;
        foreach (var item in blackCars)
        {
            WriteLine(item);
        }
    }
}

```

While the syntax of these queries is simple enough, remember that you are hitting a database each time you apply a LINQ query to the object context! Recall that when you want to obtain an independent copy of data, which can be the target of new LINQ queries, you want to use immediate execution with the `ToList<T>()`, `ToArray<T>()`, or `ToDictionary<K,V>()` extension methods (among others). Here is an update of the previous method, which performs the equivalent of a `SELECT *`, caches the entities as an array, and manipulates the array data using LINQ to Objects:

```
using (var context = new AutoLotEntities())
{
    // Get all data from the Inventory table.
    // Could also write:
    // var allData = (from item in context.Cars select item).ToArray();
    var allData = context.Cars.ToArray();

    // Get a projection of new data.
    var colorsMakes = from item in allData select new { item.Color, item.Make };
    foreach (var item in colorsMakes)
    {
        WriteLine(item);
    }

    // Get only items where Color == "Black".
    var blackCars = from item in allData where item.Color== "Black" select item;
    foreach (var item in blackCars)
    {
        WriteLine(item);
    }
}
```

To run this, update the `Main()` method to this:

```
static void Main(string[] args)
{
    WriteLine("***** Fun with ADO.NET EF *****\n");
    //int carId = AddNewRecord();
    //WriteLine(carId);
    //PrintAllInventory();
    FunWithLinqQueries();
    ReadLine();
}
```

The Role of Navigation Properties

As the name suggests, *navigation properties* allow you to capture JOIN operations in the Entity Framework programming model (without the need to author complex SQL statements). To account for these foreign key relationships, each class in your model contains virtual properties that connect your classes together. For example, in the `Inventory.cs` class, the `Orders` property is defined as virtual `ICollection<Order>`.

```
public virtual ICollection<Order> Orders { get; set; }
```

This tells EF that each Inventory database record (renamed to the Car class for the C# code) can have zero-to-many Order records.

The Order model has zero-to-one Inventory (Car) records associated with it. The Order model navigates back to the Inventory model through another virtual property of type Inventory.

```
public virtual Car Car { get; set; }
```

Lazy, Eager, and Explicit Loading

There are three ways that EF loads data into models. Lazy and Eager fetching are based on settings on the context, and the third, Explicit, is developer controlled.

Lazy Loading

The virtual modified allows EF to *lazy load* the data. This means that EF loads the bare minimum for each object and then retrieves additional details when properties are asked for in code. For example, if you had the following code, EF would call one query to get all the Cars and then for each Car execute another query to get all the Orders:

```
using (var context = new AutoLotEntities())
{
    foreach (Car c in context.Cars)
    {
        foreach (Order o in c.Orders)
        {
            WriteLine(o.OrderId);
        }
    }
}
```

Lazy loading prevents the entire database (or at least much more than was intended) to be loaded into memory. Since Orders are tied to Cars and Customers are tied to Orders, if the records were eagerly loaded, then getting all Cars would also get all Orders and Customers (except for those customers who didn't have any orders).

Eager Loading

Sometimes you *want* to load all related records. For example, if you absolutely knew you needed all Orders and all Cars, you could change the previous code to this:

```
using (var context = new AutoLotEntities())
{
    foreach (Car c in context.Cars.Include(c=>c.Orders))
    {
        foreach (Order o in c.Orders)
        {
            WriteLine(o.OrderId);
        }
    }
}
```

Then the initial query would get all Cars *and* all Orders. The Include LINQ expression instructs EF to write one query to get them all, like this:

```
SELECT
  [Project1].[CarId] AS [CarId],
  [Project1].[Make] AS [Make],
  [Project1].[Color] AS [Color],
  [Project1].[PetName] AS [PetName],
  [Project1].[C1] AS [C1],
  [Project1].[OrderId] AS [OrderId],
  [Project1].[CustId] AS [CustId],
  [Project1].[CarId1] AS [CarId1]
FROM ( SELECT
  [Extent1].[CarId] AS [CarId],
  [Extent1].[Make] AS [Make],
  [Extent1].[Color] AS [Color],
  [Extent1].[PetName] AS [PetName],
  [Extent2].[OrderId] AS [OrderId],
  [Extent2].[CustId] AS [CustId],
  [Extent2].[CarId] AS [CarId1],
  CASE WHEN ([Extent2].[OrderId] IS NULL) THEN CAST(NULL AS int) ELSE 1 END AS [C1]
FROM [dbo].[Inventory] AS [Extent1]
  LEFT OUTER JOIN [dbo].[Orders] AS [Extent2] ON [Extent1].[CarId] = [Extent2].[CarId]
) AS [Project1]
ORDER BY [Project1].[CarId] ASC, [Project1].[C1] ASC
```

The exact syntax of the query doesn't really matter; I've shown it to demonstrate that all Cars and Orders are getting retrieved in one call to the database.

Explicit Loading

Explicit loading loads a collection or class that is referenced by a navigation property. If lazy loading is disabled, then you need to either eager load related objects or explicitly load them. You can turn off lazy loading by setting the `LazyLoadingEnabled` property on the `DbContext` configuration, like this:

```
context.Configuration.LazyLoadingEnabled = false;
```

Then, to get the related object(s), you have to use the `Collection` (for collections) or `Property` (for single objects) methods of the context and `Load`. The following code shows using `Collection.Load()`:

```
foreach (Car c in context.Cars)
{
  context.Entry(c).Collection(x => x.Orders).Load();
  foreach (Order o in c.Orders)
  {
    WriteLine(o.OrderId);
  }
}
```

Deleting a Record

When you want to remove a record from the database, one way is to locate the correct item in the `DbSet<T>` and then call `Remove`, passing in that instance. You can find the correct record by calling the `Find()` method on the `DbSet<T>` and passing in the primary key of the car you want to delete. Add the following method to your class:

```
private static void RemoveRecord(int carId)
{
    // Find a car to delete by primary key.
    using (var context = new AutoLotEntities())
    {
        // See if we have it.
        Car carToDelete = context.Cars.Find(carId);
        if (carToDelete != null)
        {
            context.Cars.Remove(carToDelete);
            context.SaveChanges();
        }
    }
}
```

To run this, update the `Main()` method to this (remember to uncomment the `AddNewRecord()` line if you commented it out for the previous examples):

```
static void Main(string[] args)
{
    WriteLine("***** Fun with ADO.NET EF *****\n");
    int carId = AddNewRecord();
    RemoveRecord(carId);
    //WriteLine(carId);
    //PrintAllInventory();
    //FunWithLinqQueries();
    ReadLine();
}
```

■ **Note** Calling `Find()` before deleting a record requires an extra round-trip to the database. As you will see next, setting `EntityState` is a much more efficient way to delete records.

Deleting a Record Using EntityState

As mentioned earlier, you can delete a record using `EntityState`, which doesn't require a round-trip to the database. Add a new method named `RemoveRecordUsingEntityState()`, as follows:

```
private static void RemoveRecordUsingEntityState(int carId)
{
    using (var context = new AutoLotEntities())
    {
        Car carToDelete = new Car() { CarId = carId };
        context.Entry(carToDelete).State = EntityState.Deleted;
    }
}
```

```

try
{
    context.SaveChanges();
}
catch (DbUpdateConcurrencyException ex)
{
    WriteLine(ex);
}
}
}

```

Create a new `Car` object, set the primary key to the value you want to delete, set `EntityState` to `EntityState.Deleted`, and then call `SaveChanges()`. You gain performance (since you are not making an extra call to the database), but you lose the validation that the object exists in the database (if that matters to your scenario). If the `CarId` does not exist in the database, EF will throw a `DbUpdateConcurrencyException` in the `System.Data.Entity.Infrastructure` namespace. The exact entities in error are accessible from the `Entries` property of the exception, so you can determine which ones were in error.

■ **Note** The fact that nothing is updated does not trigger the `DbUpdateConcurrencyException` exception. It is thrown when the total number of objects that *should* be updated or deleted (based on the entity state) is greater than the total number of objects that actually were updated. The objects in error are exposed through the `Entries` property of the exception. On each entry, you can access the current values, the original values, and the current database values (by executing another query) of the properties.

Updating a Record

Updating a record is also straightforward. Locate the object you want to change, set new property values on the returned entity, and save the changes, like so:

```

private static void UpdateRecord(int carId)
{
    // Find a car to delete by primary key.
    using (var context = new AutoLotEntities())
    {
        // Grab the car, change it, save!
        Car carToUpdate = context.Cars.Find(carId);
        if (carToUpdate != null)
        {
            WriteLine(context.Entry(carToUpdate).State);
            carToUpdate.Color = "Blue";
            WriteLine(context.Entry(carToUpdate).State);
            context.SaveChanges();
        }
    }
}

```

Handling Database Changes

In this section, you created an EF solution that started with an existing database. This works great, for example, when your organization has dedicated DBAs and you are provided with a database that you don't control. As your database changes over time, all you need to do is run the wizard again and re-create your `AutoLotEntities` class; the model classes will be rebuilt for you as well. Of course, you will most likely need to refactor any code that uses your model. But hey, it wouldn't be any fun if *everything* was magically done for you!

This initial example should go a long way toward helping you understand the nuts and bolts of working with the Entity Framework.

■ **Source Code** You can find the `AutoLotConsoleApp` example in the [Chapter 23](#) subdirectory.

AutoLotDAL Version 4

In the previous section, you created the EF code from an existing database. EF can also create your database for you based on your model classes and derived `DbContext` class. In addition to creating the initial database, EF enables you to create migrations to update your database to match model changes.

■ **Note** This is the version of `AutoLotDAL.dll` that will carry forward for the rest of the book.

To get started, create a new Class Library project named `AutoLotDAL`. Delete the default class that was created and add two folders, named `EF` and `Models`. Add the Entity Framework to the project using NuGet. Right-click the project name and click `Manage NuGet Packages` (see [Figure 23-8](#)). (You didn't need to explicitly add EF to the previous example because the wizard took care of that for you. I like to add the packages in manually so I know what version is getting installed.)

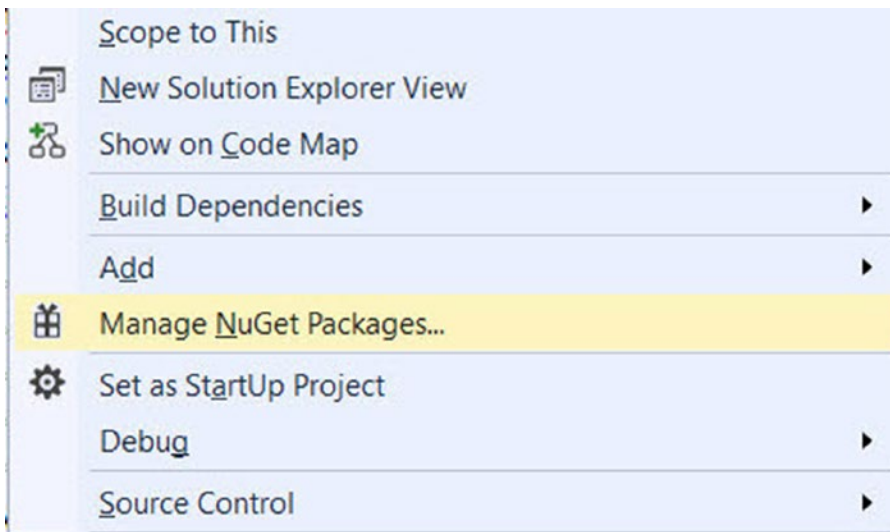

Figure 23-8. Selecting `Manage NuGet Packages`

Once the NuGet Package Manager loads, select Entity Framework (shown in [Figure 23-9](#)).

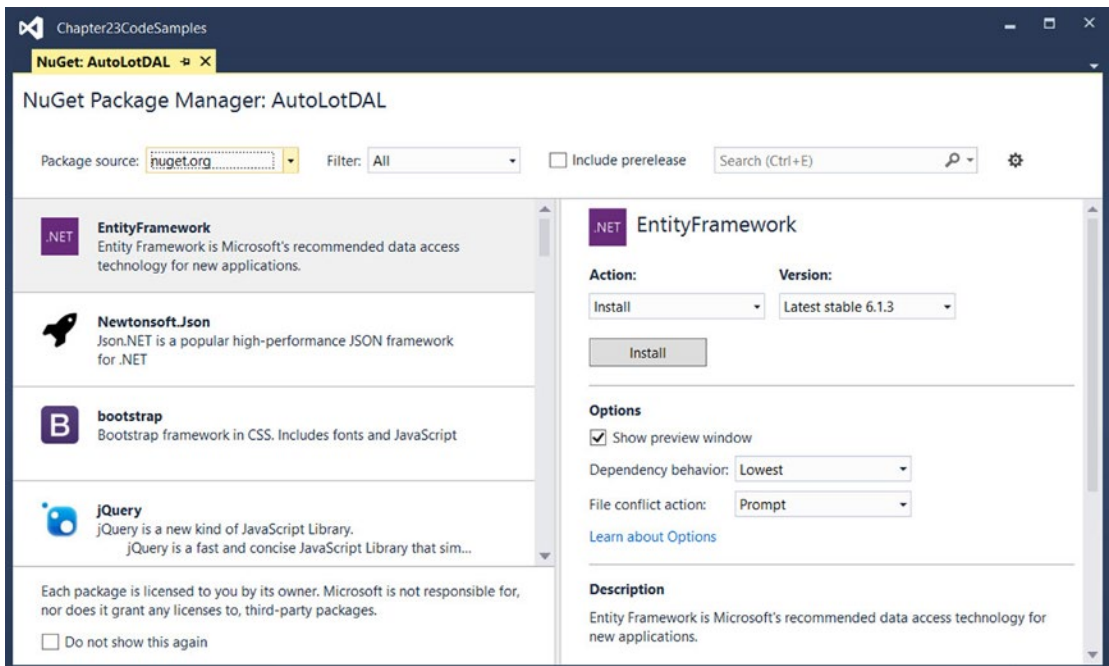

Figure 23-9. NuGet Package Manager

Accept the changes and the license agreement, and the Entity Framework (version 6.1.3 at the time of this writing) will be installed into your project.

Entity Framework Data Annotations

I briefly discussed data annotations earlier, and you saw `Table`, `Column`, `Key`, and `StringLength` in use. There are many more annotations that you can use to refine your model and add validations, and you will use many of them through the remainder of this chapter and book.

■ **Note** There are many more data annotations available in the .NET Framework than shown in Table 23-5. Consult the `System.ComponentModel.DataAnnotations` and `System.ComponentModel.DataAnnotations.Schema` namespaces in the .NET 4.6 Framework documentation for more information.

Table 23-5. *Data Annotations Supported by Entity Framework*

| Data Annotation | Meaning in Life |
|-------------------|--|
| Key | Defines the primary key for the model. This is not necessary if the key property is named <code>Id</code> or combines the class name with <code>Id</code> , such as <code>OrderId</code> . If the key is a composite, you must add the <code>Column</code> attribute with an <code>Order</code> , such as <code>Column[Order=1]</code> and <code>Column[Order=2]</code> . Key fields are implicitly also <code>[Required]</code> . |
| Required | Declares the property as not nullable. |
| ForeignKey | Declares a property that is used as the foreign key for a navigation property. |
| StringLength | Specifies the min and max lengths for a string property. |
| NotMapped | Declares a property that is not mapped to a database field. |
| ConcurrencyCheck | Flags a field to be used in concurrency checking when the database server does updates, inserts, or deletes. |
| TimeStamp | Declares a type as a row version or timestamp (depending on the database provider). |
| Table Column | Allows you to name your model classes and fields differently than how they are declared in the database. The <code>Table</code> attribute allows specification of the schema as well (as long as the data store supports schemas). |
| DatabaseGenerated | Specifies if the field is database generated. This takes one of <code>Computed</code> , <code>Identity</code> , or <code>None</code> . |
| NotMapped | Specifies that EF needs to ignore this property in regard to database fields. |
| Index | Specifies that a column should have an index created for it. You can specify clustered, unique, name, and order. |

■ **Note** In addition to data annotations, EF supports a Fluent API to define your table structure and relationships. Although you saw a small example in the earlier section, the Fluent API is beyond the scope of this chapter. You can find more information on defining tables and columns using the Fluent API here: <https://msdn.microsoft.com/en-us/data/jj591617>. You can find more information on defining relationships here: <https://msdn.microsoft.com/en-us/data/jj591620>.

Adding or Updating the Model Classes

In this section, you can either start from the model classes created in the previous example or start from scratch and create new classes as you work through the chapter exercises. I will start from scratch so you can follow the whole process from start to finish.

Start by adding a new folder named `Models` to your project and add four classes, named `CreditRisk.cs`, `Customer.cs`, `Inventory.cs`, and `Order.cs`.

Creating the Inventory Model Class

Open `Inventory.cs`, change the class to `public` and `partial`, and add the following properties as well as usings for `System.ComponentModel.DataAnnotations` and `System.ComponentModel.DataAnnotations.Schema` to the top of the class:

```
public partial class Inventory
{
    public int CarId { get; set; }
    public string Make { get; set; }
    public string Color { get; set; }
    public string PetName { get; set; }
}
```

Configuring the Model with Data Annotations

Start by using the `Table` attribute to specify the table name of `Inventory`. By default, EF uses the convention that table names are pluralized, so the default table name is `Inventories`. Add the `Key` attribute to the `CarId` property and add `StringLength(50)` for each of the string properties. The `Key` attribute indicates that the field is the primary key for the table. `StringLength(50)` sets the max length for the string property. You can also set the min length as well, although the min value is used only for validation and does not affect the creation of the database field like max does. The updated code is listed here:

```
using System.Collections.Generic;
using System.ComponentModel.DataAnnotations;
using System.ComponentModel.DataAnnotations.Schema;
namespace AutoLotDAL.Models
{
    [Table("Inventory")]
    public partial class Inventory
    {
        [Key]
        public int CarId { get; set; }

        [StringLength(50)]
        public string Make { get; set; }

        [StringLength(50)]
        public string Color { get; set; }

        [StringLength(50)]
        public string PetName { get; set; }
    }
}
```

Adding the Navigation Property to Inventory

As mentioned in the section on navigation properties, the `Orders` related to an `Inventory` record are accessed through an `ICollection<Order>`, as follows:

```
public virtual ICollection<Order> Orders { get; set; } = new HashSet<Order>();
```

The complete class is listed here:

```
using System.Collections.Generic;
using System.ComponentModel.DataAnnotations;
using System.ComponentModel.DataAnnotations.Schema;
namespace AutoLotDAL.Models
{
    [Table("Inventory")]
    public partial class Inventory
    {
        [Key]
        public int CarId { get; set; }

        [StringLength(50)]
        public string Make { get; set; }

        [StringLength(50)]
        public string Color { get; set; }

        [StringLength(50)]
        public string PetName { get; set; }

        public virtual ICollection<Order> Orders { get; set; } = new HashSet<Order>();
    }
}
```

Adding the InventoryPartial Class

You are now going to add a partial class to override the ToString() method of the Inventory class. Create a new directory under the Models directory named Partials. Add a new class named InventoryPartial.cs. Open the InventoryPartial.cs class, rename the class to Inventory, and make sure the namespace is set to AutoLotDAL.Models (not AutoLotDAL.Models.Partial, which is the default). Add the following code:

```
public partial class Inventory
{
    public override string ToString()
    {
        // Since the PetName column could be empty, supply
        // the default name of No Name.
        return $"{this.PetName ?? "No Name"} is a {this.Color} {this.Make} with ID {this.
        CarId}.";
    }
}
```

Next, add a calculated field that combines the Make and Color of the car. This is a field that is not to be stored in the database and doesn't get populated when an object is materialized with data from the database, so you need to add the [NotMapped] attribute to the property.

```
[NotMapped]
public string MakeColor => $"{Make} + ({Color})";
```

Creating the Customer Model Class

Open the `Customer.cs` class and add usings for `System.ComponentModel.DataAnnotations` and `System.ComponentModel.DataAnnotations.Schema` to the top of the class. The process is the same as you entered for the `Inventory` class, so I will just list the code here. The one item to note is the `FullName` property, which is calculated and therefore has the `NotMapped` attribute applied. Here is the class in its entirety:

```
using System.Collections.Generic;
using System.ComponentModel.DataAnnotations;
using System.ComponentModel.DataAnnotations.Schema;

namespace AutoLotDAL.Models
{
    public partial class Customer
    {
        [Key]
        public int CustId { get; set; }

        [StringLength(50)]
        public string FirstName { get; set; }

        [StringLength(50)]
        public string LastName { get; set; }

        [NotMapped]
        public string FullName => FirstName + " " + LastName;

        public virtual ICollection<Order> Orders { get; set; } = new HashSet<Order>();
    }
}
```

Creating the Order Model Class

Open the `Order.cs` class and add usings for `System.ComponentModel.DataAnnotations` and `System.ComponentModel.DataAnnotations.Schema` to the top of the class. Add the `OrderId` primary key field and then the `Customer` and `Car` navigation properties. In addition to the navigation properties, add the foreign key fields `CustId` and `CarId`. The class is shown here:

```
using System.ComponentModel.DataAnnotations;
using System.ComponentModel.DataAnnotations.Schema;

namespace AutoLotDAL.Models
{
    public partial class Order
    {
        public int OrderId { get; set; }

        public int CustId { get; set; }
    }
}
```

```

    public int CarId { get; set; }

    public virtual Customer Customer { get; set; }

    public virtual Inventory Car { get; set; }
}
}

```

Now you will apply the data annotation attributes to the `Order.cs` class. The primary key, `OrderId`, is also the primary key of the table (and therefore required) and is set up as an `Identity` column. You want to add three attributes to the `OrderId` property.

- `[Key]`: Denotes the primary key
- `[Required]`: Denotes that the field is non-nullable
- `[DatabaseGenerated(DatabaseGeneratedOption.Identity)]`: Denotes that the field is an `Identity` column

As you recall from earlier in the book, you can list all three attributes separately or together as a comma-separated list. Place them all together, and your `OrderId` property should look like this:

```

[Key, Required, DatabaseGenerated(DatabaseGeneratedOption.Identity)]
public int OrderId { get; set; }

```

Both of the values that back the navigation properties are, by default, required since the types are not nullable. However, for readability, you will mark them as required explicitly.

```

[Required]
public int CustId { get; set; }

```

```

[Required]
public int CarId { get; set; }

```

Finally, you use annotations to indicate which properties serve as the backing fields for the two navigation properties.

```

[ForeignKey("CustId")]
public virtual Customer Customer { get; set; }

```

```

[ForeignKey("CarId")]
public virtual Inventory Car { get; set; }

```

The entire class is listed here:

```

public partial class Order
{
    [Key, Required, DatabaseGenerated(DatabaseGeneratedOption.Identity)]
    public int OrderId { get; set; }

    [Required]
    public int CustId { get; set; }
}

```

```

[Required]
public int CarId { get; set; }

[ForeignKey("CustId")]
public virtual Customer Customer { get; set; }

[ForeignKey("CarId")]
public virtual Inventory Car { get; set; }
}

```

Creating the CreditRisk Class

Open the `CreditRisk.cs` class and add usings for `System.ComponentModel.DataAnnotations` and `System.ComponentModel.DataAnnotations.Schema` to the top of the class. The only changes you need to make to the `CreditRisk.cs` model class is moving to the new namespace. The initial class is shown here:

```

using System.ComponentModel.DataAnnotations;
using System.ComponentModel.DataAnnotations.Schema;
namespace AutoLotDAL.Models
{
    public partial class CreditRisk
    {
        public int CustId { get; set; }

        public string FirstName { get; set; }

        public string LastName { get; set; }
    }
}

```

Add in the `Key` attribute for `CustId` and `StringLength` attributes for `FirstName` and `LastName`. The full `Order.cs` class is shown here:

```

namespace AutoLotDAL.Models
{
    public partial class CreditRisk
    {
        [Key]
        public int CustId { get; set; }

        [StringLength(50)]
        public string FirstName { get; set; }

        [StringLength(50)]
        public string LastName { get; set; }
    }
}

```

Adding the DbContext

One important piece of the puzzle is still missing: the context class that derives from DbContext! Fortunately, this is easy to add. Select the EF folder in the AutoLotDAL project and select the Project ► Add New Item menu option. Select Data in the left sidebar, select ADO.NET Entity Data Model in the main section, and enter AutoLotEntities for the name (as shown in Figure 23-10).

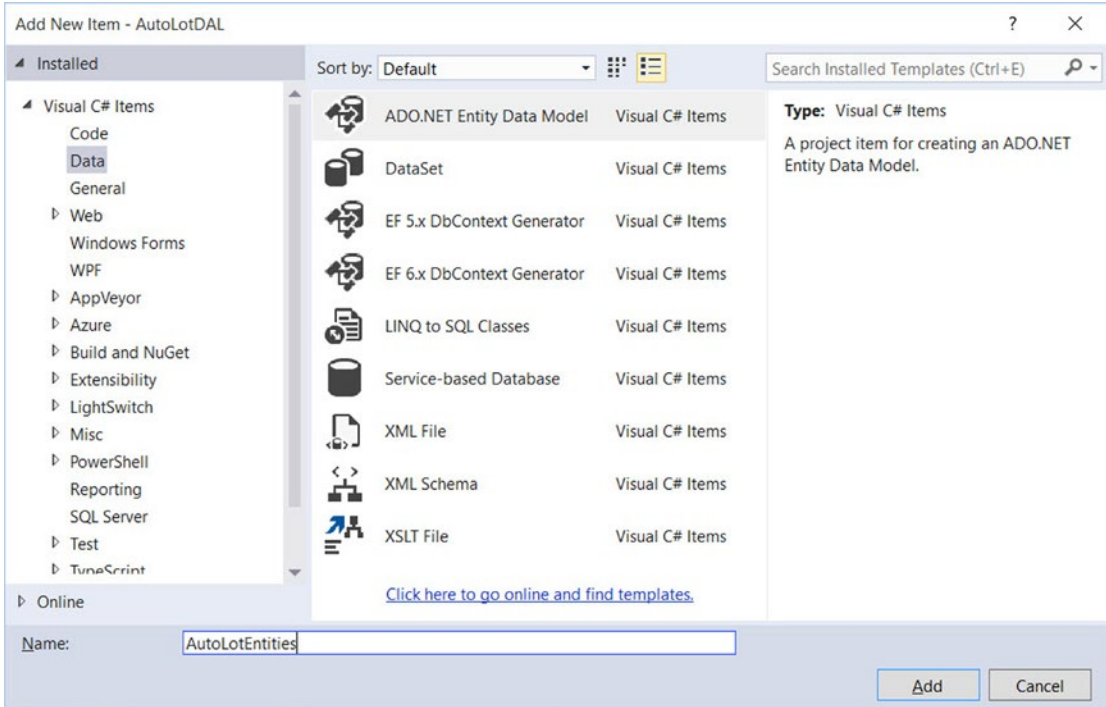

Figure 23-10. Adding a context to your project

In the Entity Data Model Wizard, select Empty Code First Model (shown in Figure 23-11).

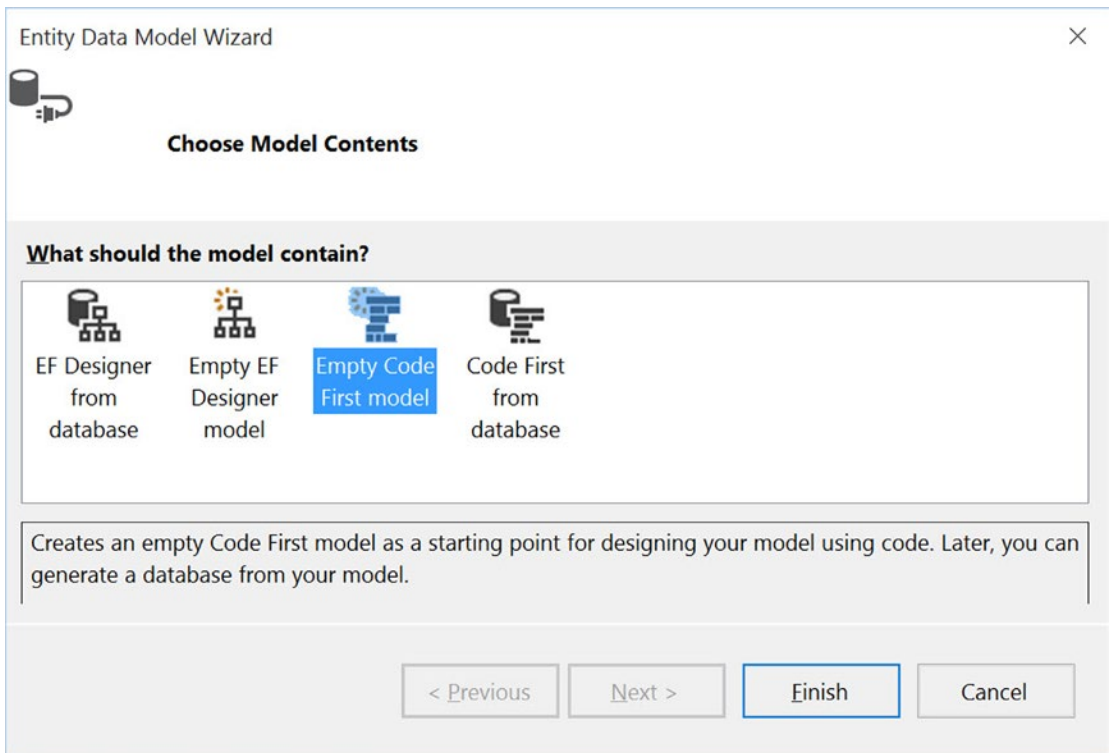

Figure 23-11. Selecting the Empty Code First model

One difference might have become apparent: the wizard never asked you for a connection string! The Code First From an Empty Database wizard presumes that there isn't a database (go figure), so it builds a new connection string for you, which you'll examine in the next section.

Updates to the *.config File and the EF Connection String

Open the App.config file and look at the changes that were made by EF. Most of them should look familiar to you. Two glaring differences are the data source and initial catalog properties in the connection string.

```
<connectionStrings>
  <add name="AutoLotEntities" connectionString="data source=(LocalDb)\MSSQLLocalDB;initial
catalog=AutoLotDAL.EF.AutoLotEntities;integrated security=True;MultipleActiveResultSets=True;
App=EntityFramework" providerName="System.Data.SqlClient" />
</connectionStrings>
```

LocalDb is a flavor of SQL Server Express targeted to application developers. It uses the minimal set of files and doesn't require any configuration on the part of the developer. Instead of a server name, such as (local)\SQLEXPRESS2014, you can use (LocalDb) with a unique name.

The catalog (database name) was derived from the namespace plus the name assigned in the wizard. In this case, it's AutoLotDAL.EF.AutoLotEntities.

Later in the chapter you will move the database to SQL Server Express (for the benefit of later chapters), but for now just change the name of the catalog to `AutoLot` and the connection string to `AutoLotConnection`.

```
<add name="AutoLotConnection" connectionString="data source=(LocalDb)\MSSQLLocalDb;initial
catalog=AutoLot;integrated security=True;MultipleActiveResultSets=True;App=EntityFramework"
providerName="System.Data.SqlClient" />
```

Update the Context

The constructor for your derived `DbContext` class passes the name of the connection string to the base `DbContext` class. Open `AutoLotEntities.cs` and change the connection string in the constructor to `AutoLotConnection`. The updated code is shown here:

```
public class AutoLotEntities : DbContext
{
    public AutoLotEntities()
        : base("name=AutoLotConnection")
    {
    }
}
```

Add the using statement for the models (`AutoLotDAL.Models`) and then add a `DbSet` for each of the model classes. The relevant code is shown here:

```
public virtual DbSet<CreditRisk> CreditRisks { get; set; }
public virtual DbSet<Customer> Customers { get; set; }
public virtual DbSet<Inventory> Inventory { get; set; }
public virtual DbSet<Order> Orders { get; set; }
```

Adding the Repositories

A common data access design pattern is the Repository pattern. As described by Martin Fowler, the core of this pattern is to mediate between the domain and data mapping layers. While the full explanation of the repository pattern is beyond the scope of this book, the pattern is helpful in eliminating duplicate code.

■ **Note** You can find more information on the repository pattern on Martin Fowler's web site at www.martinfowler.com/eaCatalog/repository.html.

Adding the IRepo Interface

One of the advantages of EF is that all the models and collections are strongly typed. You want to continue that trend with your repository classes. Start by adding a new folder in the `AutoLotDAL` project named `Repos`. Add a new interface into the `Repos` folder named `IRepo`.

The interface will expose the essential CRUD methods for your models. You will expose both the synchronous and asynchronous versions (for more information on the asynchronous versions, see Chapter 19). The full interface is listed here:

```
interface IRepo<T>
{
    int Add(T entity);
    Task<int> AddAsync(T entity);
    int AddRange(IList<T> entities);
    Task<int> AddRangeAsync(IList<T> entities);
    int Save(T entity);
    Task<int> SaveAsync(T entity);
    int Delete(int id);
    Task<int> DeleteAsync(int id);
    int Delete(T entity);
    Task<int> DeleteAsync(T entity);
    T GetOne(int? id);
    Task<T> GetOneAsync(int? id);
    List<T> GetAll();
    Task<List<T>> GetAllAsync();

    List<T> ExecuteQuery(string sql);
    Task<List<T>> ExecuteQueryAsync(string sql);
    List<T> ExecuteQuery(string sql, object[] sqlParametersObjects );
    Task<List<T>> ExecuteQueryAsync(string sql, object[] sqlParametersObjects);
}
```

The last four members allow for passing in a string SQL query (with overloads that accept parameters for the SQL string). Executing these methods will load (and track) the entities into the `DbSet<T>` of the context. These methods are not typically used, as you can build powerful queries with LINQ that hide the SQL details from the developer, but they are included here to show how to call SQL directly within the context.

■ **Note** There has been a lot of discussion on the merits and potential problems of executing data access code asynchronously from a high-volume system (such as a web application or service). I am presenting the synchronous and asynchronous mechanisms with EF in this book and leaving it up to you to test your particular application.

Adding the BaseRepo

Next, add another class to the `Repos` directory named `BaseRepo`. This class will implement the common functionality for all your repository classes, which they will all subclass. The class will be a generic class so the derived repositories can strongly type the methods. Start by adding a protected property for the `AutoLotEntities` context and instantiating it. The initial class definition is shown here:

```
using AutoLotDAL.EF;
public abstract class BaseRepo<T> where T:class,new()
{
    public AutoLotEntities Context { get; } = new AutoLotEntities();
}
```

All the actions start with the `DbSet<T>` property of the context, so add a protected property of the `DbSet<T>` named `table`, like this:

```
using AutoLotDAL.EF;
public abstract class BaseRepo<T>:where T:class,new()
{
    public AutoLotEntities Context { get; } = new AutoLotEntities();
    protected DbSet<T> Table;
}
```

Implementing the `SaveChanges()` Helper Methods

Next, add two methods for saving changes, one synchronous and the other asynchronous. These methods are merely wrappers for the `SaveChanges()` and `SaveChangesAsync()` methods of the `DbContext` and are placed here in the base class so all derived repositories can share the implementation. There is typically a significant amount of code and error handling code associated with calling these methods, and it is best to write that code only once. The exception handlers for the `SaveChanges()` method on the `DbContext` are stubbed out. In a production application, you would need to handle any exceptions accordingly.

```
internal int SaveChanges()
{
    try
    {
        return Context.SaveChanges();
    }
    catch (DbUpdateConcurrencyException ex)
    {
        //Thrown when there is a concurrency error
        //for now, just rethrow the exception
        throw;
    }
    catch (DbUpdateException ex)
    {
        //Thrown when database update fails
        //Examine the inner exception(s) for additional
        //details and affected objects
        //for now, just rethrow the exception
        throw;
    }
    catch (CommitFailedException ex)
    {
        //handle transaction failures here
        //for now, just rethrow the exception
        throw;
    }
    catch (Exception ex)
    {
        //some other exception happened and should be handled
        throw;
    }
}
```



```

internal async Task<int> SaveChangesAsync()
{
    try
    {
        return await Context.SaveChangesAsync();
    }
    catch (DbUpdateConcurrencyException ex)
    {
        //Thrown when there is a concurrency error
        //for now, just rethrow the exception
        throw;
    }
    catch (DbUpdateException ex)
    {
        //Thrown when database update fails
        //Examine the inner exception(s) for additional
        //details and affected objects
        //for now, just rethrow the exception
        throw;
    }
    catch (CommitFailedException ex)
    {
        //handle transaction failures here
        //for now, just rethrow the exception
        throw;
    }
    catch (Exception ex)
    {
        //some other exception happened and should be handled
        throw;
    }
}

```

■ **Note** Creating a new instance of the `DbContext` can be an expensive process from a performance perspective. When a new instance of your context class is created, the base `DbContext` communicates several times with the database. The amount of this communication varies based on several factors, including the complexity of the model and the number of migrations, to name a few. If you will be using this class on a client like WPF or WinForms, then in reality there won't be that many instances of this class created. If this is for a web app (like ASP.NET WebForms or ASP.NET MVC), it might be prudent to make `BaseRepo` a singleton. There isn't one absolute way because every situation is different and must be customized to your particular application.

Retrieving Records

The `GetOne()/GetOneAsync()` methods wrap the `Find()/FindAsync()` methods of the `DbSet<T>`. Similarly, the `GetAll()/GetAllAsync()` methods wrap the `ToList()/ToListAsync()` methods. The code is listed here:

```
public T GetOne(int? id) => Table.Find(id);

public Task<T> GetOneAsync(int? id) => Table.FindAsync(id);

public List<T> GetAll() => Table.ToList();

public Task<List<T>> GetAllAsync() => Table.ToListAsync();
```

Retrieving Records with SQL

The last four methods of the interface to implement are the SQL string methods. They pass through the string and parameters to the `DbSet<T>` and are shown here:

```
public List<T> ExecuteQuery(string sql) => Table.SqlQuery(sql).ToList();

public Task<List<T>> ExecuteQueryAsync(string sql)
    => Table.SqlQuery(sql).ToListAsync();

public List<T> ExecuteQuery(string sql, object[] sqlParametersObjects)
    => Table.SqlQuery(sql, sqlParametersObjects).ToList();

public Task<List<T>> ExecuteQueryAsync(string sql, object[] sqlParametersObjects)
    => Table.SqlQuery(sql).ToListAsync();
```

■ **Note** You should be extremely careful running raw SQL strings against a data store, especially if the string accepts input from a user. Doing so makes your application ripe for SQL injection attacks. This book doesn't cover security, but I do want to point out the dangers of running raw SQL statements.

Adding Records

Many of the methods can be handled in the `BaseRepo` with generics. Start with the `Add()` and `AddRange()` methods (remember that you are implementing both asynchronous and synchronous versions in your examples; you might need only one or the other). Each of the `Add()/AddRange()` methods adds a `T/IList<T>` to the `DbSet<T>` (referenced by the property `Table`). Then you need to call `SaveChanges()/SaveChangesAsync()`. The code is shown here:

```
public int Add(T entity)
{
    Table.Add(entity);
    return SaveChanges();
}
```

```

public Task<int> AddAsync(T entity)
{
    Table.Add(entity);
    return SaveChangesAsync();
}

public int AddRange(IList<T> entities)
{
    Table.AddRange(entities);
    return SaveChanges();
}
public Task<int> AddRangeAsync(IList<T> entities)
{
    Table.AddRange(entities);
    return SaveChangesAsync();
}

```

You finish the core of the `BaseRepo` by implementing the `IDisposable` interface, which helps to ensure any resources are released in a timely manner. Start by adding the `IDisposable` interface to the class and then add the following code (notice calling `Context.Dispose()` in the `Dispose()` method):

```

public abstract class BaseRepo: IDisposable
{
    protected AutoLotEntities Context { get; } = new AutoLotEntities();

    //SaveChanges and SaveChangesAsync omitted for brevity

    bool disposed = false;
    public void Dispose()
    {
        Dispose(true);
        GC.SuppressFinalize(this);
    }
    protected virtual void Dispose(bool disposing)
    {
        if (disposed)
            return;
        if (disposing)
        {
            Context.Dispose();
            // Free any managed objects here.
            //
        }

        // Free any unmanaged objects here.
        //
        disposed = true;
    }
}

```

■ **Note** You can find more information on implementing `IDisposable` at [https://msdn.microsoft.com/en-us/library/system.idisposable\(v=vs.110\).aspx](https://msdn.microsoft.com/en-us/library/system.idisposable(v=vs.110).aspx).

Updating Records

For the `Save()`/`SaveAsync()` methods, first set the `EntityState` of the entity to `EntityState.Modified` and then call `SaveChanges()`/`SaveChangesAsync()`. Setting the state ensures that the context will propagate the changes to the server. The code is listed here:

```
public int Save(T entity)
{
    Context.Entry(entity).State = EntityState.Modified;
    return SaveChanges();
}

public Task<int> SaveAsync(T entity)
{
    Context.Entry(entity).State = EntityState.Modified;
    return SaveChangesAsync();
}
```

Deleting Records

You will add similar code for the `Delete()`/`DeleteAsync()` methods. If the calling code passes in an object, the generic methods in the `BaseRepo` set the state to `EntityState.Deleted` and then call `SaveChanges()`/`SaveChangesAsync()`. The code is listed here:

```
public int Delete(T entity)
{
    Context.Entry(entity).State = EntityState.Deleted;
    return SaveChanges();
}

public Task<int> DeleteAsync(T entity)
{
    Context.Entry(entity).State = EntityState.Deleted;
    return SaveChangesAsync();
}
```

Adding the Inventory Repository

Add a new class to the Repos directory and name it `InventoryRepo.cs`. Inherit `BaseRepo<Inventory>`, implement `IRepo<Inventory>`, and assign the `Table` variable to the `DbSet<Inventory>`. The initial code should look like this:

```
public class InventoryRepo : BaseRepo<Inventory>, IRepo<Inventory>
{
    public InventoryRepo()
    {
        Table = Context.Inventory;
    }
}
```

Next, you need to implement all the members of the interface.

Deleting Records by Id

When you need to delete an `Inventory` record by the primary key, you need to create a new instance of the `Inventory` class, assign the `CarId` to the `id` parameter, and then set the state to `EntityState.Deleted`. After setting the state, call `SaveChanges/SaveChangesAsync`. The code is listed here:

```
public int Delete(int id)
{
    Context.Entry(new Inventory() {CarId=id}).State = EntityState.Deleted;
    return SaveChanges();
}

public Task<int> DeleteAsync(int id)
{
    Context.Entry(new Inventory() { CarId = id }).State = EntityState.Deleted;
    return SaveChangesAsync();
}
```

Adding the Remaining Repositories

The `CustomerRepo`, `OrderRepo`, and `CreditRiskRepo` classes follow the same pattern as the `InventoryRepo` class. Copy the `InventoryRepo.cs` class to `CreditRiskRepo.cs`, `CustomerRepo.cs`, and `OrderRepo.cs`, and update the `Delete()` methods, generic types, and constructors accordingly. They are shown here for completeness:

```
public class OrderRepo:BaseRepo<Order>,IRepo<Order>
{
    public OrderRepo()
    {
        Table = Context.Orders;
    }
    public int Delete(int id)
```

```

    {
        Context.Entry(new Order()
        {
            OrderId = id
        }).State = EntityState.Deleted;
        return SaveChanges();
    }

    public Task<int> DeleteAsync(int id)
    {
        Context.Entry(new Order()
        {
            OrderId = id
        }).State = EntityState.Deleted;
        return SaveChangesAsync();
    }
}

public class CustomerRepo:BaseRepo<Customer>,IRepo<Customer>
{
    public CustomerRepo()
    {
        Table = Context.Customers;
    }
    public int Delete(int id)
    {
        Context.Entry(new Customer()
        {
            CustId = id
        }).State = EntityState.Deleted;
        return SaveChanges();
    }

    public Task<int> DeleteAsync(int id)
    {
        Context.Entry(new Customer()
        {
            CustId = id
        }).State = EntityState.Deleted;
        return SaveChangesAsync();
    }
}

public class CreditRiskRepo:BaseRepo<CreditRisk>,IRepo<CreditRisk>
{
    public CreditRiskRepo()
    {
        Table = Context.CreditRisks;
    }
    public int Delete(int id)
    {
        Context.Entry(new CreditRisk()

```

```

    {
        CustId = id
    }).State = EntityState.Deleted;
    return SaveChanges();
}

public Task<int> DeleteAsync(int id)
{
    Context.Entry(new CreditRisk()
    {
        CustId = id
    }).State = EntityState.Deleted;
    return SaveChangesAsync();
}
}

```

Initializing the Database

A powerful feature of EF is the ability to initialize the database with data. This is especially handy during development since the process can restore the database to a known state before each run of your code. The process is to create a class that inherits from `DropCreateDatabaseIfModelChanges<TContext>` or `DropCreateDatabaseAlways<TContext>`

Start by creating a new class in the EF directory, and name the class `DataInitializer`. Inherit `DropCreateDatabaseAlways<AutoLotEntities>` and override the `Seed()` method, like this:

```

using System.Collections.Generic;
using System.Data.Entity;
using AutoLotDAL.Models;
public class DataInitializer : DropCreateDatabaseAlways<AutoLotEntities>
{
    protected override void Seed(AutoLotEntities context)
    {
    }
}

```

The `DropCreateDatabaseAlways` class is strongly typed to the `AutoLotEntities` context class and, as the name states, will drop and re-create the database every time the program is executed. Likewise, the `DropCreateDatabaseIfModelChanges<TContext>` class will drop and re-create the database only when there are changes in the model. The `Seed()` method brings an instance of your derived context that you can use to populate the tables. The process is simple: call `Add` on the correct `DbSet`, and when you are finished adding records, call `SaveChanges`. Here is an example of how to seed the database with the same records you used in the previous chapter:

```

protected override void Seed(AutoLotEntities context)
{
    var customers = new List<Customer>
    {
        new Customer {FirstName = "Dave", LastName = "Brenner"},
        new Customer {FirstName = "Matt", LastName = "Walton"},
        new Customer {FirstName = "Steve", LastName = "Hagen"},
        new Customer {FirstName = "Pat", LastName = "Walton"},
        new Customer {FirstName = "Bad", LastName = "Customer"},
    };
}

```

```

customers.ForEach(x => context.Customers.Add(x));
var cars = new List<Inventory>
{
    new Inventory {Make = "VW", Color = "Black", PetName = "Zippy"},
    new Inventory {Make = "Ford", Color = "Rust", PetName = "Rusty"},
    new Inventory {Make = "Saab", Color = "Black", PetName = "Mel"},
    new Inventory {Make = "Yugo", Color = "Yellow", PetName = "Clunker"},
    new Inventory {Make = "BMW", Color = "Black", PetName = "Bimmer"},
    new Inventory {Make = "BMW", Color = "Green", PetName = "Hank"},
    new Inventory {Make = "BMW", Color = "Pink", PetName = "Pinky"},
    new Inventory {Make = "Pinto", Color = "Black", PetName = "Pete"},
    new Inventory {Make = "Yugo", Color = "Brown", PetName = "Brownie"},
};
cars.ForEach(x => context.Inventory.Add(x));
var orders = new List<Order>
{
    new Order {Car = cars[0], Customer = customers[0]},
    new Order {Car = cars[1], Customer = customers[1]},
    new Order {Car = cars[2], Customer = customers[2]},
    new Order {Car = cars[3], Customer = customers[3]},
};
orders.ForEach(x => context.Orders.Add(x));

context.CreditRisks.Add(
    new CreditRisk
    {
        CustId = customers[4].CustId,
        FirstName = customers[4].FirstName,
        LastName = customers[4].LastName,
    });
context.SaveChanges();
}

```

The last step is to set the initializer, with the following code (which you will add in the next section):
`Database.SetInitializer(new DataInitializer());`

Test-Driving AutoLotDAL

The test-drive code is similar to what you did in the prior version of `AutoLotDal.dll`, but instead of programming directly against the context, you will be using the Repository classes. Start by adding a new Console Application project named `AutoLotTestDrive` to the solution and set this project as the Startup project. Add EF to the project through NuGet, and update the connectionStrings in `App.config` to the following:

```

<connectionStrings>
  <add name="AutoLotConnection" connectionString="data source=(LocalDb)\MSSQLLocalDb;initial
    catalog=AutoLot;integrated security=True;MultipleActiveResultSets=
    True;App=EntityFramework" providerName="System.Data.SqlClient" />
</connectionStrings>

```

Add a reference to the AutoLotDAL project. Open `Program.cs` and add the following code to the `Main()` method:

```
static void Main(string[] args)
{
    Database.SetInitializer(new DataInitializer());
    WriteLine("***** Fun with ADO.NET EF Code First *****\n");
    ReadLine();
}
```

Printing All Inventory Records

To print all records, call the `GetAll()` method on the `InventoryRepo` and then iterate through the returned list. There isn't much difference between this and coding directly against the context, but the `Repository` pattern provides a consistent way to access and operate on data across all classes.

```
private static void PrintAllInventory()
{
    using (var repo = new InventoryRepo())
    {
        foreach (Inventory c in repo.GetAll())
        {
            WriteLine(c);
        }
    }
}
```

Adding Inventory Records

Adding new records shows the simplicity of calling EF using a repository. In a production system you would want to add error handling, of course, but the work of adding a record is as simple as calling `Add()` or `AddRange()` on the repository. The code is shown here:

```
private static void AddNewRecord(Inventory car)
{
    // Add record to the Inventory table of the AutoLot
    // database.
    using (var repo = new InventoryRepo())
    {
        repo.Add(car);
    }
}
private static void AddNewRecords(IList<Inventory> cars)
{
    // Add record to the Inventory table of the AutoLot
    // database.
    using (var repo = new InventoryRepo())
    {
        repo.AddRange(cars);
    }
}
```

To test this code, add the following to the `Main()` method:

```
static void Main(string[] args)
{
    Database.SetInitializer(new MyDataInitializer());
    WriteLine("***** Fun with ADO.NET EF Code First *****\n");
    var car1 = new Inventory() { Make = "Yugo", Color = "Brown", PetName = "Brownie" };
    var car2 = new Inventory() { Make = "SmartCar", Color = "Brown", PetName = "Shorty" };
    AddNewRecord(car1);
    AddNewRecord(car2);
    AddNewRecords(new List<Inventory> { car1, car2 });
    PrintAllInventory();
    ReadLine();
}
```

Editing Records

Saving changes to records is just as simple. Get an `Inventory` object, make some changes, and call `Save()` on the `InventoryRepo` class. The code is shown here (with some extra code to output the `EntityState` of the object along the way):

```
private static void UpdateRecord(int carId)
{
    using (var repo = new InventoryRepo())
    {
        // Grab the car, change it, save!
        var carToUpdate = repo.GetOne(carId);
        if (carToUpdate != null)
        {
            WriteLine("Before change: " + repo.Context.Entry(carToUpdate).State);
            carToUpdate.Color = "Blue";
            WriteLine("After change: " + repo.Context.Entry(carToUpdate).State);
            repo.Save(carToUpdate);
            WriteLine("After save: " + repo.Context.Entry(carToUpdate).State);
        }
    }
}
```

To test this code, add the following to the `Main()` method:

```
static void Main(string[] args)
{
    Database.SetInitializer(new MyDataInitializer());
    WriteLine("***** Fun with ADO.NET EF Code First *****\n");
    var car1 = new Inventory() { Make = "Yugo", Color = "Brown", PetName = "Brownie" };
    var car2 = new Inventory() { Make = "SmartCar", Color = "Brown", PetName = "Shorty" };
    AddNewRecord(car1);
    AddNewRecord(car2);
    AddNewRecords(new List<Inventory> { car1, car2 });
}
```

```

UpdateRecord(car1.CarId);
PrintAllInventory();
ReadLine();
}

```

Using Navigation Properties

Add a method named `ShowAllOrders()`. In the method, add a `using` statement around the `OrdersRepo` class. For each record returned from the `GetAll()` method, print the `itm.Customer.FullName` and `itm.Car.PetName` properties. The code is shown here:

```

private static void ShowAllOrders()
{
    using (var repo = new OrderRepo())
    {
        WriteLine("***** Pending Orders *****");
        foreach (var itm in repo.GetAll())
        {
            WriteLine($"->{itm.Customer.FullName} is waiting on {itm.Car.PetName}");
        }
    }
}

```

Add a call to the method in the `Main()` method. When you run the program, you will get output similar to this (your mileage will vary based on the data currently in your database):

```

***** Fun with ADO.NET EF Code First *****

```

```

***** Pending Orders *****
-> Dave Brenner is waiting on Bimmer
-> Matt Walton is waiting on Zippy
-> Steve Hagen is waiting on Clunker
-> Pat Walton is waiting on Pinky

```

If you look at the Output window when you run the app, you will see that there are many individual database calls made to the database: one to get all of the orders and then additional calls to get each individual Customer name and Car PetName. This is because of lazy loading, as discussed earlier in this chapter. Next, you will use eager loading with the `InventoryRepo`.

To call this from `Main()`, add the following line:

```
ShowAllOrders();
```

Eager Loading

Begin by adding a using statement for `System.Data.Entity`. Next, create a method named `ShowAllOrdersEagerlyFetched()`. You need to code directly against `AutoLotEntities` since you don't have a Repo method to eagerly fetch the data. (If this is something that you will use often, you can add it into the `OrderRepo` class.) The new method is shown here:

```
private static void ShowAllOrdersEagerlyFetched()
{
    using (var context = new AutoLotEntities())
    {
        WriteLine("***** Pending Orders *****");
        var orders = context.Orders
            .Include(x => x.Customer)
            .Include(y => y.Car)
            .ToList();
        foreach (var itm in orders)
        {
            WriteLine($"->{itm.Customer.FullName} is waiting on {itm.Car.PetName}");
        }
    }
}
```

To call this from `Main()`, add the following line:

```
ShowAllOrdersEagerlyFetched();
```

Multitable Actions/Implicit Transactions

As you recall, EF automatically enlists all changes that are propagated with a `SaveChanges` call into an implicit transaction. Replicating the transaction example in Chapter 22 of moving a record from the `Customer` table to the `CreditRisk` table is extremely simple. The repositories that you have coded so far work on only one table at a time, so you need to code directly against the context.

Start by creating a method named `MakeCustomerARisk()`. This method will remove a customer from the `Customers` table into the `CreditRisk` table. Since there isn't a `Move()` method, you have to code it as a two-stage operation. Add to `CreditRisk` and then `Delete` from `Customers`. When an entity is brought into existence with one context, you have to detach it and then connect it to the new context. That is the reason for setting `EntityState` to `EntityState.Detached` in `Main()` and then calling `Attach()` on the new context. The code is shown here:

```
private static CreditRisk MakeCustomerARisk(Customer customer)
{
    using (var context = new AutoLotEntities())
    {
        context.Customers.Attach(customer);
        context.Customers.Remove(customer);
        var creditRisk = new CreditRisk()
        {
            FirstName = customer.FirstName,
            LastName = customer.LastName
        };
    }
}
```

```

context.CreditRisks.Add(creditRisk);
try
{
    context.SaveChanges();
}
catch (DbUpdateException ex)
{
    WriteLine(ex);
}
catch (Exception ex)
{
    WriteLine(ex);
}
return creditRisk;
}
}

```

To show the results of this, create a method called `PrintAllCustomersAndCreditRisks()`. Use the existing repository classes to iterate through the `Customer` and `CreditRisk` records.

```

private static void PrintAllCustomersAndCreditRisks()
{
    WriteLine("***** Customers *****");
    using (var repo = new CustomerRepo())
    {
        foreach (var cust in repo.GetAll())
        {
            WriteLine($"->{cust.FirstName} {cust.LastName} is a Customer.");
        }
    }
    WriteLine("***** Credit Risks *****");
    using (var repo = new CreditRiskRepo())
    {
        foreach (var risk in repo.GetAll())
        {
            WriteLine($"->{risk.FirstName} {risk.LastName} is a Credit Risk!");
        }
    }
}
}

```

Call these methods from the `Main()` method, passing in a new `Customer` object, similar to this:

```

WriteLine("***** Fun with ADO.NET EF Code First *****\n");
PrintAllCustomersAndCreditRisks();
var customerRepo = new CustomerRepo();
var customer = customerRepo.GetOne(4);
customerRepo.Context.Entry(customer).State = EntityState.Detached;
var risk = MakeCustomerARisk(customer);
PrintAllCustomersAndCreditRisks();

```

If one of the operations (deleting from `Customer` or adding to `CreditRisk`) fail, both operations will fail.

■ **Source Code** You can find the `AutoLotTestDrive` example in the Chapter 23 subdirectory.

Entity Framework Migrations

You created this version of `AutoLotDAL.dll` from code and then created the database. Each time the application is run, the database is dropped and re-created through the initialization process. This works great in development, but once you deploy your app to production, you can't keep dropping the database every time your users run the app. If your model changes, you need to keep your database in sync. This is where EF migrations come into play. Before creating your first migration, you are going to make some changes to illustrate the problem. Start by opening `Program.cs` and comment out the following line: `Database.SetInitializer(new MyDataInitializer());`

■ **Note** As discussed earlier, the data initializer drops and re-creates the database, either each time the app runs or when the model changes. If you don't comment out the `SetInitializer` line, this next section won't work for you.

Updating the Model

Suppose the business has requested a few changes to the application, including concurrency checking. To do this, you will add a `Timestamp` property to all your tables (you will learn about concurrency checking with EF in the next section). Recall from the list of data annotations that the `Timestamp` attribute is used for this. In SQL Server, the `Timestamp` annotations maps to the `RowVersion` data type, which in C# is represented by the `byte[]` data type. This is the only change that you will make this time for the `Inventory`, `Customer`, and `Order` classes. You will also add the `Timestamp` property to the `CreditRisk`, but you are going to make some additional changes to that class in the next section. The updated `Inventory`, `Customer`, and `Order` classes are listed next.

Inventory Class

Here is the `Inventory` class:

```
[Table("Inventory")]
public partial class Inventory
{
    [Key]
    public int CarId { get; set; }

    [StringLength(50)]
    public string Make { get; set; }

    [StringLength(50)]
    public string Color { get; set; }

    [StringLength(50)]
    public string PetName { get; set; }
}
```

```

[Timestamp]
public byte[] Timestamp { get; set; }

public virtual ICollection<Order> Orders { get; set; } = new HashSet<Order>();
}

```

Customer Class

Here is the Customer class:

```

public partial class Customer
{
    [Key]
    public int CustId { get; set; }

    [StringLength(50)]
    public string FirstName { get; set; }

    [StringLength(50)]
    public string LastName { get; set; }

    [Timestamp]
    public byte[] Timestamp { get; set; }

    [NotMapped]
    public string FullName => FirstName + " " + LastName;

    public virtual ICollection<Order> Orders { get; set; } = new HashSet<Order>();
}

```

Order Class

Here is the Order class:

```

public partial class Order
{
    [Key, Required, DatabaseGenerated(DatabaseGeneratedOption.Identity)]
    public int OrderId { get; set; }

    [Required]
    public int CustId { get; set; }

    [Required]
    public int CarId { get; set; }

    [Timestamp]
    public byte[] Timestamp { get; set; }
}

```

```

[ForeignKey("CustId")]
public virtual Customer Customer { get; set; }

[ForeignKey("CarId")]
public virtual Inventory Car { get; set; }
}

```

Credit Risk Class

In addition to the `Timestamp` property, you are going to create a unique index on the `FirstName` and `LastName` properties using data annotations. Since this is a complex key, you also need to specify a name for the index and the order for each column in the index. In this example, the index name is `IDX_CreditRisk_Name`, and the column order for the index is `LastName` and then `FirstName` and is created as a unique index. The updated code is shown here:

```

public partial class CreditRisk
{
    [Key]
    public int CustId { get; set; }

    [StringLength(50)]
    [Index("IDX_CreditRisk_Name", IsUnique = true, Order=2)]
    public string FirstName { get; set; }

    [StringLength(50)]
    [Index("IDX_CreditRisk_Name", IsUnique = true, Order = 1)]
    public string LastName { get; set; }

    [Timestamp]
    public byte[] Timestamp { get; set; }
}

```

Testing the App

Comment everything out of the `Main()` method in `Program.cs` except for the call to `PrintAllInventory()` (like the following code snippet) and run the app.

```

static void Main(string[] args)
{
    WriteLine("***** Fun with ADO.NET EF Code First *****\n");
    PrintAllInventory();
    ReadLine();
}

```

You will get a `System.InvalidOperationException` with the following error message:

The model backing the 'AutoLotEntities' context has changed since the database was created. Consider using Code First Migrations to update the database (<http://go.microsoft.com/fwlink/?LinkId=238269>).

Entering EF Migrations

How did EF know that the database and the model were out of sync? Before EF makes its first call to the database, it looks for a table named `__MigrationHistory` and compares a hash of the current EF model to the most recent hash stored in the table. If you open the `AutoLot` database in Server Explorer, you will see one record. This was created automatically by EF when it created the database. Now that you have changed your model, you need to create a new migration entry.

■ **Note** When you create your model from an existing database, the `__MigrationHistory` table does *not* get created (at least at the time of this writing). Why does it matter? When your `DbContext` class is instantiated and before the first call to the database from your custom code, EF checks the migration history. Since this table doesn't exist, there are a series of exceptions generated. As you well know, exceptions can be expensive operations, and this can potentially cause a performance issue. Even if you don't ever plan on using migrations, you should enable migrations as covered in the next section.

Creating the Baseline Migration

Start by enabling migrations for your project. To do this, open the Package Manager Console (the command-line tool for managing NuGet packages) by selecting `View ► Other Windows ► Package Manager Console`. Make sure `Default Project` is set to `AutoLotDAL` and enter `enable-migrations`, as shown in Figure 23-12.

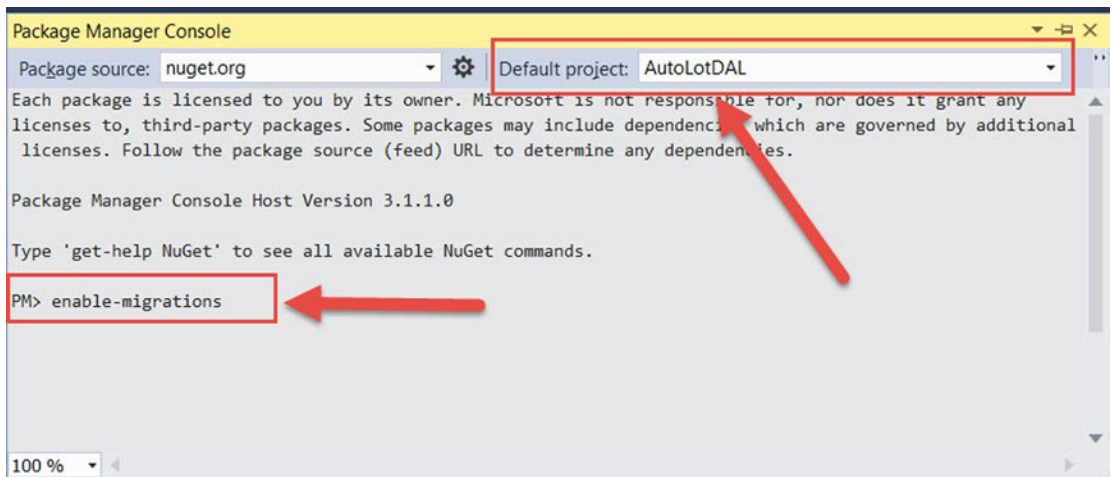

Figure 23-12. Enabling migrations on `AutoLotDAL`

This creates a `Migrations` folder with two classes: `Configuration.cs` and `201510060510505_InitialCreate.cs`. Note: The name of the second file is based on the date and CPU time followed by the name of the migration. This format for the name enables EF to run migrations in the correct chronological order (if more than one exists). Since you did not specify a name when you enabled migrations, the migration name defaulted to `InitialCreate`.

Open the `InitialCreate.cs` class. This class has two methods named `Up()` and `Down()`. The `Up()` method is for applying the changes to the database, and the `Down()` method is to roll back the changes. EF built the database based on your model prior to the changes you made in the previous section and populated the `__MigrationHistory` table with the hash of these tables and fields. If you examine the `InitialCreate` class, you will see that the `Timestamp` fields and the additional index in the `CreditRisk` table aren't listed. The file should look like this:

```
public partial class InitialCreate : DbMigration
{
    public override void Up()
    {
        CreateTable(
            "dbo.CreditRisks",
            c => new
            {
                CustId = c.Int(nullable: false, identity: true),
                FirstName = c.String(maxLength: 50),
                LastName = c.String(maxLength: 50),
            })
            .PrimaryKey(t => t.CustId);

        CreateTable(
            "dbo.Customers",
            c => new
            {
                CustId = c.Int(nullable: false, identity: true),
                FirstName = c.String(maxLength: 50),
                LastName = c.String(maxLength: 50),
            })
            .PrimaryKey(t => t.CustId);

        CreateTable(
            "dbo.Orders",
            c => new
            {
                OrderId = c.Int(nullable: false, identity: true),
                CustId = c.Int(nullable: false),
                CarId = c.Int(nullable: false),
            })
            .PrimaryKey(t => t.OrderId)
            .ForeignKey("dbo.Inventory", t => t.CarId, cascadeDelete: true)
            .ForeignKey("dbo.Customers", t => t.CustId, cascadeDelete: true)
            .Index(t => t.CustId)
            .Index(t => t.CarId);

        CreateTable(
            "dbo.Inventory",
            c => new
            {
                CarId = c.Int(nullable: false, identity: true),
                Make = c.String(maxLength: 50),
            })
            .PrimaryKey(t => t.CarId);
    }
}
```

```

        Color = c.String(maxLength: 50),
        PetName = c.String(maxLength: 50),
    })
    .PrimaryKey(t => t.CarId);
}

public override void Down()
{
    DropForeignKey("dbo.Orders", "CustId", "dbo.Customers");
    DropForeignKey("dbo.Orders", "CarId", "dbo.Inventory");
    DropIndex("dbo.Orders", new[] { "CarId" });
    DropIndex("dbo.Orders", new[] { "CustId" });
    DropTable("dbo.Inventory");
    DropTable("dbo.Orders");
    DropTable("dbo.Customers");
    DropTable("dbo.CreditRisks");
}
}

```

The `Configuration.cs` class also has one method and some constructor code. The code in the constructor instructs EF to disable automatic migrations (which is the setting you will use most of the time, since you want to have control over how migrations work) and sets the `ContextKey` (in the base class) to the fully qualified name of your derived `DbContext` class. The `Seed()` method enables you to add data to the database, which you will use shortly.

```

internal sealed class Configuration : DbMigrationsConfiguration<AutoLotDAL.
EF.AutoLotEntities>
{
    public Configuration()
    {
        AutomaticMigrationsEnabled = false;
        ContextKey = "AutoLotDAL.EF.AutoLotEntities";
    }

    protected override void Seed(AutoLotDAL.EF.AutoLotEntities context)
    {
    }
}

```

To create a migration, type `add-migration TimeStamps` in the Package Manager Console. `add-migration` instructs EF to take a hash of the current model and compare it to the most recent hash in the `__MigrationHistory` table. The second parameter is the name for the migration, which can be anything but should be meaningful to you. Executing this command (Figure 23-13) creates a new file under the `Migrations` folder with the name `<timestamp>_TimeStamps.cs`.

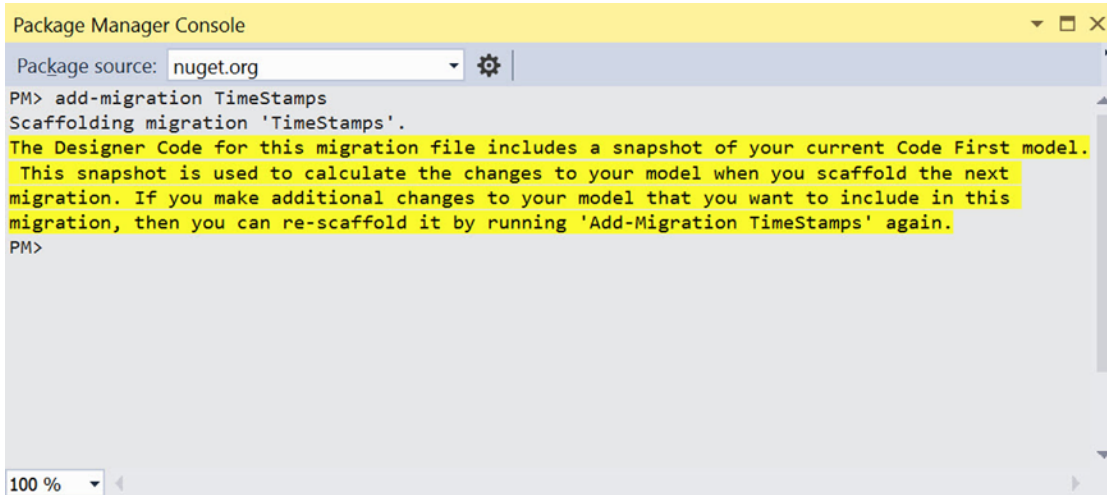

Figure 23-13. Creating the initial migration

Open the new file (mine is named 201510062307304_TimeStamps.cs) and examine the contents. Again, it has an Up() method that applies the changes and a Down() method that rolls back the changes. The file is listed here:

```
public partial class TimeStamps : DbMigration
{
    public override void Up()
    {
        AddColumn("dbo.CreditRisks", "Timestamp",
            c => c.Binary(nullable: false, fixedLength: true, timestamp: true, storeType:
                "rowversion"));
        AddColumn("dbo.Customers", "Timestamp",
            c => c.Binary(nullable: false, fixedLength: true, timestamp: true, storeType:
                "rowversion"));
        AddColumn("dbo.Orders", "Timestamp",
            c => c.Binary(nullable: false, fixedLength: true, timestamp: true, storeType:
                "rowversion"));
        AddColumn("dbo.Inventory", "Timestamp",
            c => c.Binary(nullable: false, fixedLength: true, timestamp: true, storeType:
                "rowversion"));
        CreateIndex("dbo.CreditRisks", new[] { "LastName", "FirstName" },
            unique: true, name: "IDX_CreditRisk_Name");
    }

    public override void Down()
    {
        DropIndex("dbo.CreditRisks", "IDX_CreditRisk_Name");
        DropColumn("dbo.Inventory", "Timestamp");
        DropColumn("dbo.Orders", "Timestamp");
    }
}
```

```

DropColumn("dbo.Customers", "Timestamp");
DropColumn("dbo.CreditRisks", "Timestamp");
}
}

```

The final task is to update the database. Type update-database in the Package Manager Console, and you will get a message that the migration has been applied. Open Server Explorer, and refresh the Tables node. You will see the `__MigrationHistory` table. If you select Show Table Data on the table, you will see something similar to Figure 23-14.

| MigrationId | ContextKey | Model | ProductVersion |
|----------------------------|-------------------------------|---|----------------|
| 510060510505_InitialCreate | AutoLotDAL.EF.AutoLotEntities | 0x1F8B080000000000400ED5ACD6EE33610B... | 6.1.3-40302 |
| 201510062307304_TimeStamps | AutoLotDAL.EF.AutoLotEntities | 0x1F8B080000000000400ED58DB6EE336107... | 6.1.3-40302 |
| NULL | NULL | NULL | NULL |

Figure 23-14. The contents of the `__MigrationHistory` table

Seeding the Database

The `Seed()` method in `Configure.cs` leverages the `AddOrUpdate()` method on the `DbSet` class. The `AddOrUpdate()` method takes two parameters; the first is a lambda representing the unique field(s) to identify for updating, and the second is the record to add (or update) in the database. The base syntax is this:

```

context.Customers.AddOrUpdate(c=> c.CustId,
    new Customer {CustId = 1, FirstName="Foo",LastName="Bar"});

```

In this example, you aren't checking by the primary key since it's an identity. You want to check to make sure the `FirstName` and `LastName` combination is unique. To use a complex identifier, you create an anonymous object to identify the fields, instead of a single property, like this:

```

context.Customers.AddOrUpdate(c=> new {c.FirstName,c.LastName},
    new Customer { FirstName="Foo",LastName="Bar"});

```

Copy the code from the `DataInitialize` class into the `Seed()` method. Change the `Add()` calls to `AddOrUpdate()`, as shown here:

```

protected override void Seed(AutoLotDAL.EF.AutoLotEntities context)
{
    var customers = new List<Customer>
    {
        new Customer {FirstName = "Dave", LastName = "Brenner"},
        new Customer {FirstName = "Matt", LastName = "Walton"},
        new Customer {FirstName = "Steve", LastName = "Hagen"},
        new Customer {FirstName = "Pat", LastName = "Walton"},
        new Customer {FirstName = "Bad", LastName = "Customer"},
    };
}

```

```

customers.ForEach(x =>
    context.Customers.AddOrUpdate(c=> new { c.FirstName,c.LastName},x));

var cars = new List<Inventory>
{
    new Inventory {Make = "VW", Color = "Black", PetName = "Zippy"},
    new Inventory {Make = "Ford", Color = "Rust", PetName = "Rusty"},
    new Inventory {Make = "Saab", Color = "Black", PetName = "Mel"},
    new Inventory {Make = "Yugo", Color = "Yellow", PetName = "Clunker"},
    new Inventory {Make = "BMW", Color = "Black", PetName = "Bimmer"},
    new Inventory {Make = "BMW", Color = "Green", PetName = "Hank"},
    new Inventory {Make = "BMW", Color = "Pink", PetName = "Pinky"},
    new Inventory {Make = "Pinto", Color = "Black", PetName = "Pete"},
    new Inventory {Make = "Yugo", Color = "Brown", PetName = "Brownie"},
};
cars.ForEach(x =>
    context.Inventory.AddOrUpdate(i => new { i.Make, i.Color, i.PetName }, x));

var orders = new List<Order>
{
    new Order {Car = cars[0], Customer = customers[0]},
    new Order {Car = cars[1], Customer = customers[1]},
    new Order {Car = cars[2], Customer = customers[2]},
    new Order {Car = cars[3], Customer = customers[3]},
};
orders.ForEach(x =>
    context.Orders.AddOrUpdate(o => new { o.CarId, o.CustId }, x));

context.CreditRisks.AddOrUpdate(c => new { c.FirstName, c.LastName },
    new CreditRisk
    {
        CustId = customers[4].CustId,
        FirstName = customers[4].FirstName,
        LastName = customers[4].LastName,
    });
}

```

The `Seed()` methods runs each time you run `update-database` from the Package Manager Console. To seed the database, open the Package Manager Console, type `update-database`, and hit Enter.

Revisiting the Transaction Test

Now that you have a unique index for the `CreditRisk` table based on the customer first and last names, update the `MakeACustomerRisk()` method to add the new record twice. Because of the implicit transaction created when `SaveChanges()` is called, not only will the customer not be added to the `CreditRisk` table (either time), but the customer will not be removed from the `Customer` table. Add a try-catch block around

the call to `SaveChanges()` catching the `DbUpdateException`. In the catch block, write the exception to the console. When you run the application, you see that indeed the changes to the database are not made, and the exception detail is written to the console window. The updated code is shown here:

```
private static CreditRisk MakeCustomerARisk(Customer customer)
{
    using (var context = new AutoLotEntities())
    {
        context.Customers.Attach(customer);
        context.Customers.Remove(customer);
        var creditRisk = new CreditRisk()
        {
            FirstName = customer.FirstName,
            LastName = customer.LastName
        };
        context.CreditRisks.Add(creditRisk);
        var creditRiskDupe = new CreditRisk()
        {
            FirstName = customer.FirstName,
            LastName = customer.LastName
        };
        context.CreditRisks.Add(creditRiskDupe);
        try
        {
            context.SaveChanges();
        }
        catch (DbUpdateException ex)
        {
            WriteLine(ex);
        }

        return creditRisk;
    }
}
```

Concurrency

A common problem in multiuser applications is concurrency issues. If your application does not check for concurrency issues, when two users update the same record, the last one in wins. This might be perfectly fine for your application, but if not, EF and SQL Server provide a convenient mechanism for checking for concurrency clashes.

When you added the timestamp properties to your model classes in the previous section, it changed how EF builds and runs queries that update or delete data from the database. A call to delete no longer just looks for the primary key (`CarId`) but also looks for the `Timestamp`. For example, the generated SQL looks like this:

```
Execute NonQuery "DELETE [dbo].[Inventory] WHERE (([CarId] = @0) AND ([Timestamp] = @1))"
```

EF automatically added the timestamp as part of the WHERE clause on the delete. This prevents one user (or process) from stepping on another user's (or process's) changes. If the delete call isn't working with the most recent version of record, nothing will be updated, and a `DbUpdateConcurrencyException` will be raised.

Correcting the Repositories

The `Delete(int id)` and `DeleteAsync(int id)` methods in the repos will now fail every time they are called because the `Timestamp` is not being passed in. Correct the method definitions in the `IRepo<T>` interface first to accept a timestamp value. The updated code is shown here:

```
int Delete(int id, byte[] timeStamp);
Task<int> DeleteAsync(int id, byte[] timeStamp);
```

Now update all the repositories to leverage the new method signatures. The relevant code from the `InventoryRepo` class is shown here (the rest of the repositories follow the same pattern, and the updated code can be found in the sample download):

```
public int Delete(int id, byte[] timeStamp)
{
    Context.Entry(new Inventory()
    {
        CarId=id,
        Timestamp = timeStamp
    }).State = EntityState.Deleted;
    return SaveChanges();
}

public Task<int> DeleteAsync(int id, byte[] timeStamp)
{
    Context.Entry(new Inventory()
    {
        CarId = id,
        Timestamp = timeStamp
    }).State = EntityState.Deleted;
    return SaveChangesAsync();
}
```

Testing Concurrency

The following code demonstrates concurrency checking on an `Inventory` record. It replicates two different users updating the same record. When the users get the records from the database, the timestamps are the same. When one user updates their record, the timestamp is updated by SQL Server, but the second user hasn't refreshed their object, so the timestamp value is still the original value. When that user attempts to save the record, the timestamps don't match, the `SaveChanges` call doesn't update any records, and the exception is thrown. The updated code is shown here:

```
private static void UpdateRecordWithConcurrency()
{
    var car = new Inventory()
    { Make = "Yugo", Color = "Brown", PetName = "Brownie" };
    AddNewRecord(car);
```



```

var repo1 = new InventoryRepo();
var car1 = repo1.GetOne(car.CarId);
car1.PetName = "Updated";

var repo2 = new InventoryRepo();
var car2 = repo2.GetOne(car.CarId);
car2.Make = "Nissan";

repo1.Save(car1);
try
{
    repo2.Save(car2);
}
catch (DbUpdateConcurrencyException ex)
{
    WriteLine(ex);
}
RemoveRecordById(car1.CarId, car1.Timestamp);
}

```

All this code does is expose the problem. You still need to decide what to do when a concurrency error occurs. That will depend on your specific business requirements.

Interception

The final topic in this chapter regarding EF covers interception. As you have seen in the previous examples, a lot of “magic” happens behind the scenes for the data to move from the data store into your object model, and vice versa. Interception is the process of running code at different phases of the process.

The IDbCommandInterceptor Interface

It all starts with the `IDbCommandInterceptor` interface, listed here:

```

public interface IDbCommandInterceptor : IDbInterceptor
{
    void NonQueryExecuted(DbCommand command,
        DbCommandInterceptionContext<int> interceptionContext);
    void NonQueryExecuting(DbCommand command,
        DbCommandInterceptionContext<int> interceptionContext);
    void ReaderExecuted(DbCommand command,
        DbCommandInterceptionContext<DbDataReader> interceptionContext);
    void ReaderExecuting(DbCommand command,
        DbCommandInterceptionContext<DbDataReader> interceptionContext);
    void ScalarExecuted(DbCommand command,
        DbCommandInterceptionContext<object> interceptionContext);
    void ScalarExecuting(DbCommand command,
        DbCommandInterceptionContext<object> interceptionContext);
}

```

As you can probably infer from the names, this interface contains methods that are called by EF just prior and just after certain events. For example, the `ReaderExecuting()` method is called just *before* a reader is executed, and `ReaderExecuted()` is called just *after* a reader is executed. For this example, you will simply write to the console in each of these methods. In a production system, the logic will be more appropriate to your requirements.

Adding Interception to AutoLotDAL

Add a new folder named `Interception` to the `AutoLotDAL` project and a new class to the folder name `ConsoleWriterInterceptor`. Make the class public, add `System.Data.Entity.Infrastructure`. `Interception` as a `using`, and inherit from `IDbCommandInterceptor`. After you implement the missing members, your code should look like this:

```
public class ConsoleWriterInterceptor : IDbCommandInterceptor
{
    public void NonQueryExecuting(DbCommand command,
        DbCommandInterceptionContext<int> interceptionContext)
    {
    }

    public void NonQueryExecuted(DbCommand command,
        DbCommandInterceptionContext<int> interceptionContext)
    {
    }

    public void ReaderExecuting(DbCommand command,
        DbCommandInterceptionContext<DbDataReader> interceptionContext)
    {
    }

    public void ReaderExecuted(DbCommand command,
        DbCommandInterceptionContext<DbDataReader> interceptionContext)
    {
    }

    public void ScalarExecuting(DbCommand command,
        DbCommandInterceptionContext<object> interceptionContext)
    {
    }

    public void ScalarExecuted(DbCommand command,
        DbCommandInterceptionContext<object> interceptionContext)
    {
    }
}
```

To keep the example simple, you are just going to write to the console whether the call is asynchronous and the text of the command. Add a `using` for `static System.Console` and add a private method named `WriteInfo()` that takes a `bool` and a `string`. The code is listed here:

```
private void WriteInfo(bool isAsync, string commandText)
{
    WriteLine($"IsAsync: {isAsync}, Command Text: {commandText}");
}
```

In each of the methods from the interface, add a call to the `WriteInfo()` method like this:

```
WriteInfo(interceptionContext.IsAsync, command.CommandText);
```

Registering the Interceptor

Interceptors can be registered through code or in the application configuration file. Registering them in code isolates them from changes to the configuration file and therefore ensures that they are always registered. If you need more flexibility, the configuration file might be the better choice. For this example, you are going to register the interceptor in code.

Open the `AutoLotEntities.cs` class and add the following usings:

```
using System.Data.Entity.Infrastructure;
using System.Data.Entity.Infrastructure.Interception;
```

Next, in the constructor, add the following line of code:

```
DbInterception.Add(new ConsoleWriterInterceptor());
```

Execute one of the test methods from earlier in this chapter, and you will see the additional output from the logger written to the console. This is a simple example but illustrates the capabilities of the interceptor class.

■ **Note** The `DbCommandInterceptionContext<T>` contains much more than you have explored here. Please consult the .NET Framework 4.6 SDK documentation for more information.

Adding the DatabaseLogger Interceptor

EF now ships with a built-in logging interceptor if all you want to do is simple logging. To add this capability, start by opening the `AutoLotEntities.cs` class and comment out your console logger. Add a static read-only member of type `DatabaseLogger` (in the `System.Data.Entity.Infrastructure.Interception` namespace). The constructor takes two parameters; the first is the file name for the log file, and the second is optional and indicates whether the log should be appended to (the default is false). In the constructor, call `StartLogging()` on the interceptor and add the instance to the list of interceptors. The updated code is shown here:

```
static readonly DatabaseLogger DatabaseLogger =
    new DatabaseLogger("sqllog.txt", true);
public AutoLotEntities() : base("name=AutoLotConnection")
{
    //DbInterception.Add(new ConsoleWriterInterceptor());
    DatabaseLogger.StartLogging();
    DbInterception.Add(DatabaseLogger);
}
```

The last change is to leverage the `DbContext` implementation of the `IDisposable` pattern to stop logging and remove the interceptor. The code is shown here:

```
protected override void Dispose(bool disposing)
{
    DbInterception.Remove(DatabaseLogger);
    DatabaseLogger.StopLogging();
    base.Dispose(disposing);
}
```

ObjectMaterialized and SavingChanges Events

The `ObjectContext` class contains two events, `ObjectMaterialized` and `SavingChanges`. These events can save you from creating an interceptor—as long as they meet your needs, that is! The `ObjectMaterialized` event fires when an object is reconstituted from the data store, and the `SavingChanges` event occurs when the object's data is about to be propagated to the data store, just after the `SaveChanges()` method is called on the context.

Accessing the Object Context

As you recall, the context is derived from the `DbContext` class. Fortunately, it also extends the `IObjectContextAdapter` interface. To get to the `ObjectContext`, you need to cast `AutoLotEntities` to `IObjectContextAdapter`. You do this in the constructor like this:

```
public AutoLotEntities(): base("name=AutoLotConnection")
{
    //Interceptor code
    var context = (this as IObjectContextAdapter).ObjectContext;
    context.ObjectMaterialized += OnObjectMaterialized;
    context.SavingChanges += OnSavingChanges;
}

private void OnSavingChanges(object sender, EventArgs eventArgs)
{
}

private void OnObjectMaterialized(object sender,
System.Data.Entity.Core.Objects.ObjectMaterializedEventArgs e)
{
}
```

ObjectMaterialized

The `ObjectMaterialized` event's arguments provide access to the entity being reconstituted. While you won't use this event in this chapter, you will need it for Chapter 30. For now, suffice it to say that this event fires immediately after a model class's properties are populated by EF and before the context serves it up to the calling code.

SavingChanges

As mentioned, the `SavingChanges` event fires just after the `SaveChanges()` method is called (on the `DbContext`) but before the database is updated. By accessing the `ObjectContext` passed into the event handler, all the entities in the transaction are accessible through the `ObjectStateEntry` property on the `DbContext`. Table 23-6 shows some of the key properties.

Table 23-6. *Key Members of ObjectStateEntry*

| Member of DbContext | Meaning in Life |
|-----------------------------|--|
| <code>CurrentValues</code> | The current values of the entity's properties |
| <code>OriginalValues</code> | The original values of the entity's properties |
| <code>Entity</code> | The entity represented by the <code>ObjectStateEntry</code> object |
| <code>State</code> | The current state of the entity (e.g., Modified, Added, Deleted) |

The `ObjectStateEntry` also exposes a set of methods that can be used on the entity. Some of these are listed in Table 23-7.

Table 23-7. *Key Methods of ObjectStateEntry*

| Member of DbContext | Meaning in Life |
|------------------------------------|---|
| <code>AcceptChanges</code> | Accepts the current values as the original values |
| <code>ApplyCurrentValues</code> | Sets the current values to match those of a supplied object |
| <code>ApplyOriginalValues</code> | Sets the original values to match those of a supplied object |
| <code>ChangeState</code> | Updates the state of the entity |
| <code>GetModifiedProperties</code> | Returns the names of all changed properties |
| <code>IsPropertyChanges</code> | Checks a specific property for changes |
| <code>RejectPropertyChanges</code> | The current state of the entity (e.g. Modified, Added, Deleted) |

This permits you to write code that rejects any changes to a vehicle's color if the color is red, like this:

```
private void OnSavingChanges(object sender, EventArgs eventArgs)
{
    //Sender is of type ObjectContext. Can get current and original values, and
    //cancel/modify the save operation as desired.
    var context = sender as ObjectContext;
    if (context == null) return;
    foreach (ObjectStateEntry item in
        context.ObjectStateManager.GetObjectStateEntries(
            EntityState.Modified | EntityState.Added))
    {
        //Do something important here
        if ((item.Entity as Inventory)!=null)
        {
            var entity = (Inventory) item.Entity;
```

```

        if (entity.Color == "Red")
        {
            item.RejectPropertyChanges(nameof(entity.Color));
        }
    }
}
}

```

■ **Source Code** You can find the updated AutoLotDAL example in the Chapter 23 subdirectory.

Deploying to SQL Server

As the final step, you will deploy your database to SQL Server Express. This is as simple as changing the connection string and executing update-database! Open the App.config file in AutoLotDAL and update the connection string to point to SQL Server Express. Note: I also changed the name of the default catalog since I already have an AutoLot database in SQL Express. The exact string will depend on how you installed SQL Server, but it should look something like this:

```

<connectionStrings>
  <add name="AutoLotConnection" connectionString="data source=.\SQLEXPRESS2014;initial
    catalog=AutoLot2;integrated security=True;MultipleActiveResultSets=True;App=EntityFramework"
    providerName="System.Data.SqlClient" />
</connectionStrings>

```

When you run update database, you will see the updates getting applied (as in Figure 23-15).

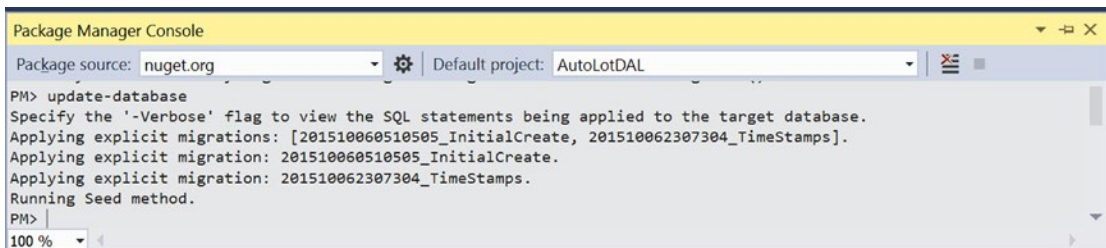

Figure 23-15. Deploying to SQL Server Express

■ **Source Code** If you have an issue with the migrations not executing, the Package Manager Console might be using the console app as the target. You can specify the following to rectify the situation: Update-Database -ProjectName AutoLotDAL -StartupProjectName AutoLotDAL

Summary

Over the past three chapters, you went on a tour of three approaches to data manipulation using ADO.NET, specifically the connection layer, the disconnected layer, and the Entity Framework. Each approach has merit, and many of your applications will likely use various aspects of each of them. Now to be sure, you have only scratched the surface of all the topics found within the ADO.NET technology set. To dive deeper into any of the topics presented in this book (as well to examine a number of related items), I recommend consulting the .NET Framework 4.6 SDK documentation.

This chapter wrapped up your formal investigation of database programming using ADO.NET by examining the role of the Entity Framework. EF allows you to program against a conceptual model that closely maps to your business domain. While you can reshape your entities in any way you choose, the EF runtime ensures that the changed data is mapped to the correct physical table data.

Along the way you learned about data annotations, which is one way to describe the mapping between your domain model and the database model. You learned about how EF handles transactions; creating, saving, and deleting data; and how entity state fits in.

You then used database migrations to keep the changes to your model in sync with the database, checked for concurrency errors, and added logging and interception. Finally, you walked through a lot of different examples while test-driving `AutoLotDAL.dll`.

CHAPTER 24



Introducing LINQ to XML

As a .NET developer, you are bound to encounter XML-based data in numerous places. Application and web-based configuration files store information as XML. Windows Presentation Foundation uses an XML-based grammar (XAML) to represent desktop GUIs. ADO.NET DataSets can easily save out (or load in) data as XML. Even Windows Communication Foundation stores numerous settings as the well-formatted string called XML.

Although XML is indeed everywhere, programming with XML has historically been tedious, verbose, and complex if you are not well versed in a great number of XML technologies (XPath, XQuery, XSLT, DOM, SAX, etc.). Since the inception of the .NET platform, Microsoft has provided a specific assembly, named `System.Xml.dll`, devoted to programming with XML documents. Within this binary are a number of namespaces and types to various XML programming techniques, as well as a few .NET-specific XML APIs such as the `XmlReader/XmlWriter` classes.

These days, most .NET programmers prefer to interact with XML data using the LINQ to XML API. As you will see in this chapter, the LINQ to XML programming model allows you to capture the structure of an XML data in code and provides a much simpler way to create, manipulate, load, and save XML data. While you could use LINQ to XML as little more than a simpler way to create XML documents, you can also easily incorporate LINQ query expressions into the mix to quickly query a document for information.

A Tale of Two XML APIs

When the .NET platform was first introduced, programmers were able to manipulate XML documents using the types within the `System.Xml.dll` assembly. Using the contained namespaces and types, you were able to generate XML data in memory and save it to disk storage. As well, the `System.Xml.dll` assembly provided types allowing you to load XML documents into memory, search an XML document for specific nodes, validate a document against a given schema, and other common programming tasks.

While this original library has been used successfully in many .NET projects, working with these types was a bit cumbersome (to put it politely), as the programming model bore no relationship to the structure of the XML document itself. For example, assume you needed to build an XML file in memory and save it to the file system. If you were to use the types of `System.Xml.dll`, you might author code like the following (if you want to follow along, create a new Console Application project named `LinqToXmlFirstLook` and import the `System.Xml` namespace):

```
private static void BuildXmlDocWithDOM()
{
    // Make a new XML document in memory.
    XmlDocument doc = new XmlDocument();
```



```

// Fill this document with a root element
// named <Inventory>.
XmlElement inventory = doc.CreateElement("Inventory");

// Now, make a subelement named <Car> with
// an ID attribute.
XmlElement car = doc.CreateElement("Car");
car.SetAttribute("ID", "1000");

// Build the data within the <Car> element.
XmlElement name = doc.CreateElement("PetName");
name.InnerText = "Jimbo";
XmlElement color = doc.CreateElement("Color");
color.InnerText = "Red";
XmlElement make = doc.CreateElement("Make");
make.InnerText = "Ford";

// Add <PetName>, <Color>, and <Make> to the <Car>
// element.
car.AppendChild(name);
car.AppendChild(color);
car.AppendChild(make);

// Add the <Car> element to the <Inventory> element.
inventory.AppendChild(car);

// Insert the complete XML into the XmlDocument object,
// and save to file.
doc.AppendChild(inventory);
doc.Save("Inventory.xml");
}

```

If you were to call this method, you would be able to see that the `Inventory.xml` file (located in the `bin\Debug` folder) contains the following data:

```

<Inventory>
  <Car ID="1000">
    <PetName>Jimbo</PetName>
    <Color>Red</Color>
    <Make>Ford</Make>
  </Car>
</Inventory>

```

While this method works as expected, a few observations are in order. First, the programming model of `System.Xml.dll` is Microsoft's implementation of the W3C Document Object Model (DOM) specification. Under this model, an XML document is created from the bottom up. First you create a document, then you create subelements, and finally you add the elements to the document. To account for this in code, you need to author quite a bit of function calls off the `XmlDocument` and `XmlElement` classes (among others).

For this example, it took 16 lines of code (not including code comments) to build even this simple XML document. If you needed to build a more complex document with the `System.Xml.dll` assembly, you could end up with a great deal of code. While you could certainly streamline this code, by building nodes via various looping or decision constructs, the fact remains that the body of code has little visual indicators regarding the final XML tree.

LINQ to XML As a Better DOM

The LINQ to XML API is an alternative manner to create, manipulate, and query XML documents, which uses a much more functional approach than the `System.Xml` DOM model. Rather than building an XML document by assembling elements individually and updating the XML tree through a set of function calls, you can author top-down code such as the following:

```
private static void BuildXmlDocWithLINQToXml()
{
    // Create an XML document in a more "functional" manner.
    XElement doc =
        new XElement("Inventory",
            new XElement("Car", new XAttribute("ID", "1000"),
                new XElement("PetName", "Jimbo"),
                new XElement("Color", "Red"),
                new XElement("Make", "Ford")
            )
        );
    // Save to file.
    doc.Save("InventoryWithLINQ.xml");
}
```

Here, you are using a new set of types from the `System.Xml.Linq` namespace, specifically `XElement` and `XAttribute`. If you were to call this method, you would find the same XML data has been created, this time with much less fuss and bother. Notice how, through some careful indentation, your source code has the same overall structure of the resulting XML document. This is useful in and of itself, but also notice that you have a much smaller body of code than the previous example (based on how you space your code, you saved about ten lines!)

Here, you have not made use of any LINQ query expressions but have simply used the types of the `System.Xml.Linq` namespace to generate an in-memory XML document, which is then saved to file. Effectively, you have used LINQ to XML as a better DOM. As you will see later in this chapter, the classes of `System.Xml.Linq` are LINQ-aware and can be the target for the same sort of LINQ queries you learned about in Chapter 12.

As you learn more about LINQ to XML, you will most likely find it much easier to work with than the initial XML libraries of .NET. This is not to say you will never use the namespaces of the original `System.Xml.dll` library; however, chances are that the times you will opt to use `System.Xml.dll` for new projects will be significantly reduced.

VB Literal Syntax As a Better LINQ to XML

Before you begin your formal examination into LINQ to XML as seen through C#, I do want to briefly mention that the Visual Basic language takes the functional approach of this API to the next level. In VB, you can define *XML literals*, which allow you to assign an XElement to a stream of inline XML markup, directly in code. Assuming you had a VB project, you could build the following method:

```
Public Class XmlLiteralExample
  Public Sub MakeXmlFileUsingLiterals()
    ' Notice that we can inline XML data
    ' to an XElement.
    Dim doc As XElement =
      <Inventory>
        <Car ID="1000">
          <PetName>Jimbo</PetName>
          <Color>Red</Color>
          <Make>Ford</Make>
        </Car>
      </Inventory>

    ' Save to file.
    doc.Save("InventoryVBStyle.xml")
  End Sub
End Class
```

After the VB compiler processes the XML literal, it will map the XML data into the correct underlying LINQ to XML object model. In fact, when you are working with LINQ to XML within a VB project, the IDE already understands that your XML literal syntax is just a shorthand notation for the related code. In Figure 24-1, notice how you can apply the dot operator to the </Inventory> end tag and see the same members as you would find if you apply the dot operator to a strongly typed XElement.

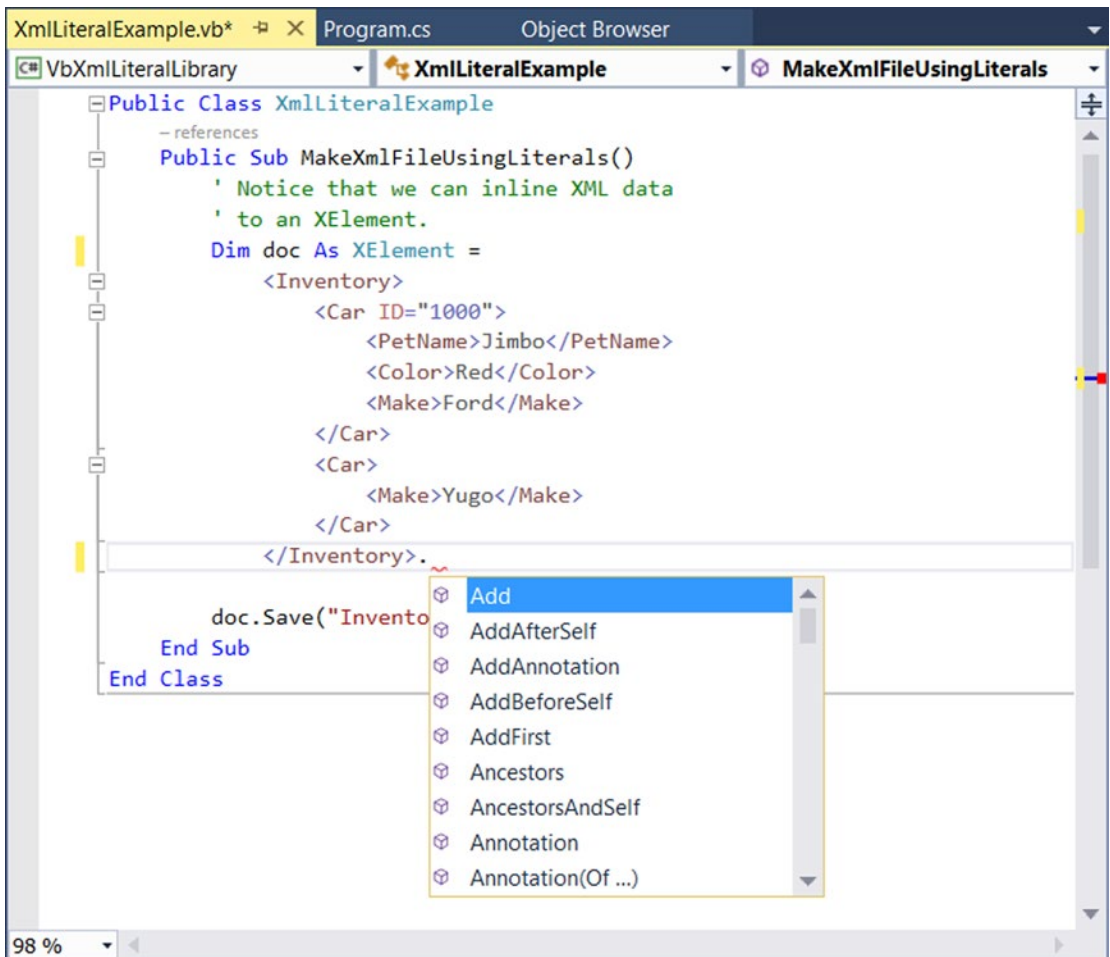

Figure 24-1. VB XML literal syntax is a shorthand notation for working with the LINQ to XML object model

Although this book is about the C# programming language, few developers can argue that VB's XML support is quite awesome. Even if you are the sort of developer who can't imagine using a language from the BASIC family for your data-to-day development, I encourage you to check out VB literal syntax using the .NET Framework 4.6 SDK documentation. You could find yourself isolating your XML data-manipulation routines to a dedicated *.dll, just so you can use VB to do so!

Members of the System.Xml.Linq Namespace

Somewhat surprisingly, the core LINQ to XML assembly (`System.Xml.Linq.dll`) defines a small number of types in three distinct namespaces, specifically `System.Xml.Linq`, `System.Xml.Schema`, and `System.Xml.XPath` (see Figure 24-2).

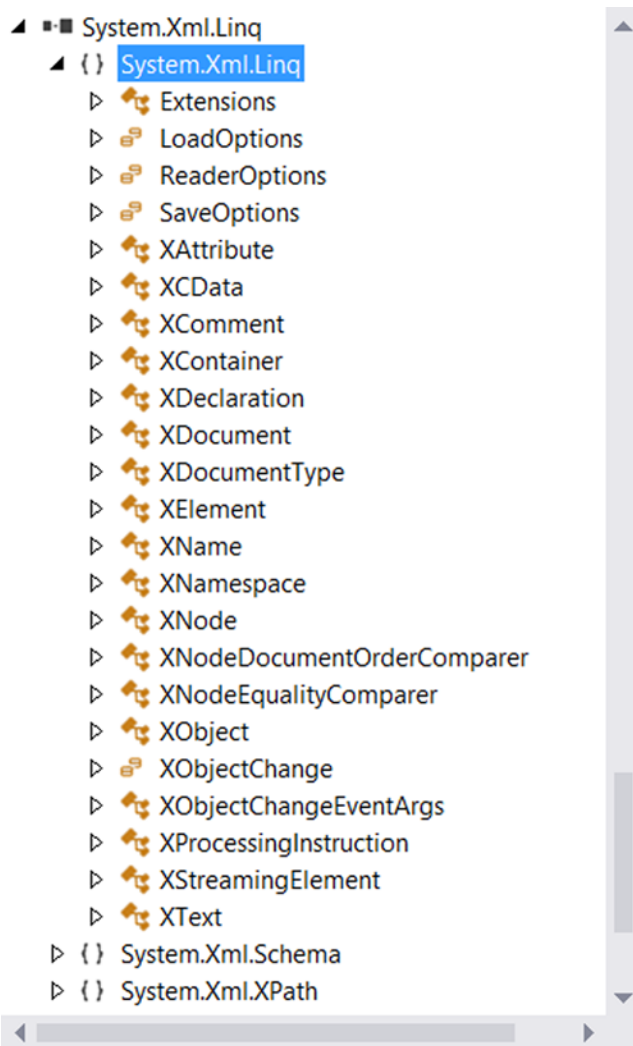

Figure 24-2. The namespaces of System.Xml.Linq.dll

The core namespace, System.Xml.Linq, contains a manageable set of classes that represent various aspects of an XML document (its elements and their attributes, XML namespaces, XML comments, processing instructions, etc.). Table 24-1 documents the core members of System.Xml.Linq.

Table 24-1. Select Members of the System.Xml.Linq Namespace

| Member of System.Xml.Linq | Meaning in Life |
|---------------------------|---|
| XAttribute | Represents an XML attribute on a given XML element. |
| XCDATA | Represents a CDATA section in the XML document. Information in a CDATA section represents data in an XML document that must be included but does not conform to the rules of XML grammars (for example, script code). |
| XComment | Represents an XML comment. |
| XDeclaration | Represents the opening declaration of an XML document. |
| XDocument | Represents the entirety of an XML document. |
| XElement | Represents a given element within an XML document, including the root element. |
| XName | Represents the name of an XML element or XML attribute. |
| XNamespace | Represents an XML namespace. |
| XNode | Represents the abstract concept of a node (element, comment, document type, processing instruction, or text node) in the XML tree. |
| XProcessingInstruction | Represents an XML processing instruction. |
| XStreamingElement | Represents elements in an XML tree that supports deferred streaming output. |

Figure 24-3 shows how the inheritance chain of the key class types.

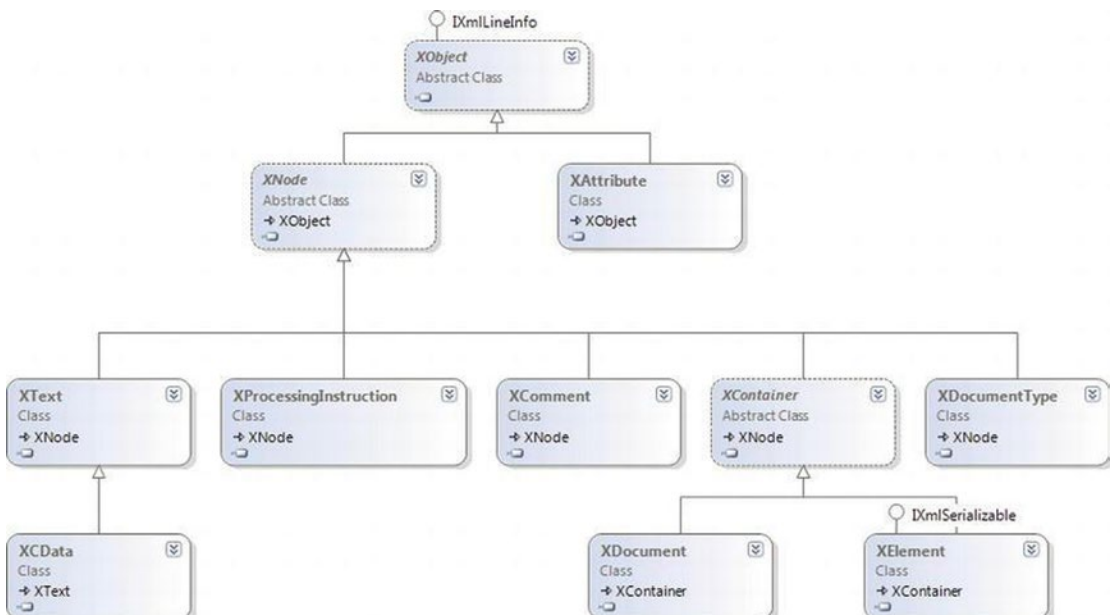
**Figure 24-3.** The LINQ to XML core class hierarchy

The LINQ to XML Axis Methods

In addition to the *X** classes, `System.Xml.Linq` defines a class named `Extensions`, which (of course) defines a set of extension methods that typically extend `IEnumerable<T>`, where `T` is some descendant of `XNode` or `XContainer`. Table 24-2 documents some of the important extension methods to be aware of (as you will see, these are useful when you want to work with LINQ queries).

Table 24-2. *Select Members of the LINQ to XML Extensions Class*

| Member of Extensions | Meaning in Life |
|---|---|
| <code>Ancestors<T>()</code> | Returns a filtered collection of elements that contains the ancestors of every node in the source collection. |
| <code>Attributes()</code> | Returns a filtered collection of the attributes of every element in the source collection. |
| <code>DescendantNodes<T>()</code> | Returns a collection of the descendant nodes of every document and element in the source collection. |
| <code>Descendants<T></code> | Returns a filtered collection of elements that contains the descendant elements of every element and document in the source collection. |
| <code>Elements<T></code> | Returns a collection of the child elements of every element and document in the source collection. |
| <code>Nodes<T></code> | Returns a collection of the child nodes of every document and element in the source collection. |
| <code>Remove()</code> | Removes every attribute in the source collection from its parent element. |
| <code>Remove<T>()</code> | Removes all occurrences of a given node from the source collection. |

As you can tell from their names, these methods allow you to query a loaded XML tree to find elements, attributes, and their values. Collectively, these methods are termed *axis methods*, or simply *axes*. You can apply these methods directly to parts of a tree of nodes or use them to build more elaborate LINQ queries.

■ **Note** The abstract `XContainer` class support a number of methods that are identically named to the members of `Extensions`. `XContainer` is the parent to both `XElement` and `XDocument`; therefore, they both support the same overall functionality.

You'll see examples of using some of these axis methods over the chapter. However, here is a quick example:

```
private static void DeleteNodeFromDoc()
{
    XElement doc =
        new XElement("Inventory",
            new XElement("Car", new XAttribute("ID", "1000"),
                new XElement("PetName", "Jimbo"),
                new XElement("Color", "Red"),
                new XElement("Make", "Ford")
            )
        );
};
```

```
// Delete the PetName element from the tree.
doc.Descendants("PetName").Remove();
Console.WriteLine(doc);
}
```

If you were to invoke this method, you'd see the following "pruned" XML tree:

```
<Inventory>
  <Car ID="1000">
    <Color>Red</Color>
    <Make>Ford</Make>
  </Car>
</Inventory>
```

The Oddness of XName (and XNamespace)

If you examine the signatures of the LINQ to XML axis methods (or the identically named members of `XContainer`), you'll notice that they typically require you to specify what looks to be an `XName` object. Consider the following signature of the `Descendants()` method defined by `XContainer`:

```
public IEnumerable<XElement> Descendants(XName name)
```

`XName` is "odd" in that you will never really directly use it in your code. In fact, since this class has no public constructor, you cannot make an `XName` object, as demonstrated here:

```
// Error! Can't make XName objects!
doc.Descendants(new XName("PetName")).Remove();
```

If you were to view the formal definition of `XName`, you would see that this class defines a custom implicit conversion operator (see Chapter 11 for information of defining custom conversion operators), which will map a simple `System.String` to the correct `XName` object.

```
// We really make an XName in the background!
doc.Descendants("PetName").Remove();
```

■ **Note** The `XNamespace` class also supports the same flavor of implicit string conversion.

The good news is that you can use textual values to represent the names of elements or attributes when you work with these axis methods and allow the LINQ to XML API to map your string data to the necessary object types.

■ **Source Code** The `LinqToXmlFirstLook` example can be found in the Chapter 24 subdirectory.

Working with XElement and XDocument

Let's continue the investigation of LINQ to XML with a new Console Application project named `ConstructingXmlDocs`. After you have created the project, import the `System.Xml.Linq` namespace into your initial code file. As you have already seen, `XDocument` represents the entirety of an XML document in the LINQ to XML programming model, as it can be used to define a root element and all contained elements, processing instructions, and XML declarations. Here is another example of building XML data using `XDocument`:

```
static void CreateFullXDocument()
{
    XDocument inventoryDoc =
        new XDocument(
            new XDeclaration("1.0", "utf-8", "yes"),
            new XComment("Current Inventory of cars!"),
            new XProcessingInstruction("xml-stylesheet",
                "href='MyStyles.css' title='Compact' type='text/css'"),
            new XElement("Inventory",
                new XElement("Car", new XAttribute("ID", "1"),
                    new XElement("Color", "Green"),
                    new XElement("Make", "BMW"),
                    new XElement("PetName", "Stan")
                ),
                new XElement("Car", new XAttribute("ID", "2"),
                    new XElement("Color", "Pink"),
                    new XElement("Make", "Yugo"),
                    new XElement("PetName", "Melvin")
                )
            )
        );
}

// Save to disk.
inventoryDoc.Save("SimpleInventory.xml");
}
```

Again, notice that the constructor of the `XDocument` object is, in fact, a tree of additional LINQ to XML objects. The constructor called here takes as the first parameter an `XDeclaration`, followed by a parameter array of objects (recall, C# parameter arrays allow you to pass in a comma-delimited list of arguments, which are packaged as an array on your behalf):

```
public XDocument(System.Xml.Linq.XDeclaration declaration, params object[] content)
```

If you were to invoke this method from `Main()`, you'd see the following data in the `SimpleInventory.xml` file:

```
<?xml version="1.0" encoding="utf-8" standalone="yes"?>
<!--Current Inventory of cars!-->
<?xml-stylesheet href='MyStyles.css' title='Compact' type='text/css'?>
<Inventory>
  <Car ID="1">
    <Color>Green</Color>
    <Make>BMW</Make>
    <PetName>Stan</PetName>
  </Car>
  <Car ID="2">
    <Color>Pink</Color>
    <Make>Yugo</Make>
    <PetName>Melvin</PetName>
  </Car>
</Inventory>
```

As it turns out, the default XML declaration for any `XDocument` is to use UTF-8 encoding, XML version 1.0, as a stand-alone document. Therefore, you could completely delete the creation of the `XDeclaration` object and end up with the same data; given that just about every document requires this same declaration, use of `XDeclaration` is typically not that common.

If you do not need to define processing instructions or a custom XML declaration, you can avoid the use of `XDocument` altogether and simply use `XElement`. Remember, `XElement` can be used to represent the root element of the XML document and all subobjects. Thus, you could generate a commented list of inventory items as so:

```
static void CreateRootAndChildren()
{
  XElement inventoryDoc =
    new XElement("Inventory",
      new XComment("Current Inventory of cars!"),
      new XElement("Car", new XAttribute("ID", "1"),
        new XElement("Color", "Green"),
        new XElement("Make", "BMW"),
        new XElement("PetName", "Stan")
      ),
      new XElement("Car", new XAttribute("ID", "2"),
        new XElement("Color", "Pink"),
        new XElement("Make", "Yugo"),
        new XElement("PetName", "Melvin")
      )
    );

  // Save to disk.
  inventoryDoc.Save("SimpleInventory.xml");
}
```

The output is more or less identical, sans the custom processing instruction for a hypothetical style sheet.

```
<?xml version="1.0" encoding="utf-8"?>
<Inventory>
  <!--Current Inventory of cars!-->
  <Car ID="1">
    <Color>Green</Color>
    <Make>BMW</Make>
    <PetName>Stan</PetName>
  </Car>
  <Car ID="2">
    <Color>Pink</Color>
    <Make>Yugo</Make>
    <PetName>Melvin</PetName>
  </Car>
</Inventory>
```

Generating Documents from Arrays and Containers

So far, you have been building XML documents using fixed hard-coded constructor values. More commonly, you will need to generate XElements (or XDocuments) by reading data from arrays, ADO.NET objects, file data, or whatnot. One way to map in-memory data to a new XElement is by using a set of standard for loops to move data into the LINQ to XML object model. While this is certainly doable, it is more streamlined to embed a LINQ query within the construction of the XElement directly.

Assume you have an anonymous array of anonymous classes (just to avoid the amount of code for this example; any array, List<T>, or other container would do here). You could map this data into an XElement as so:

```
static void MakeXElementFromArray()
{
  // Create an anonymous array of anonymous types.
  var people = new[] {
    new { FirstName = "Mandy", Age = 32},
    new { FirstName = "Andrew", Age = 40 },
    new { FirstName = "Dave", Age = 41 },
    new { FirstName = "Sara", Age = 31}
  };

  XElement peopleDoc =
    new XElement("People",
      from c in people select new XElement("Person", new XAttribute("Age", c.Age),
        new XElement("FirstName", c.FirstName))
    );
  Console.WriteLine(peopleDoc);
}
```

Here, the `peopleDoc` object defines the root `<People>` element with the results of a LINQ query. This LINQ query creates new `XElements` based on each item in the `people` array. If this embedded query is a bit hard on the eyes, you could break things down into explicit steps, like so:

```
static void MakeXElementFromArray()
{
    // Create an anonymous array of anonymous types.
    var people = new[] {
        new { FirstName = "Mandy", Age = 32},
        new { FirstName = "Andrew", Age = 40 },
        new { FirstName = "Dave", Age = 41 },
        new { FirstName = "Sara", Age = 31}
    };

    var arrayDataAsXElements = from c in people
        select
            new XElement("Person",
                new XAttribute("Age", c.Age),
                new XElement("FirstName", c.FirstName));
    XElement peopleDoc = new XElement("People", arrayDataAsXElements);
    Console.WriteLine(peopleDoc);
}
```

Either way, the output is the same.

```
<People>
  <Person Age="32">
    <FirstName>Mandy</FirstName>
  </Person>
  <Person Age="40">
    <FirstName>Andrew</FirstName>
  </Person>
  <Person Age="41">
    <FirstName>Dave</FirstName>
  </Person>
  <Person Age="31">
    <FirstName>Sara</FirstName>
  </Person>
</People>
```

Loading and Parsing XML Content

The `XElement` and `XDocument` types both support `Load()` and `Parse()` methods, which allow you to hydrate an XML object model from string objects containing XML data or external XML files. Consider the following method, which illustrates both approaches:

```
static void ParseAndLoadExistingXml()
{
    // Build an XElement from string.
    string myElement =
        @"<Car ID = '3'>
        <Color>Yellow</Color>
        <Make>Yugo</Make>
        </Car>";
    XElement newElement = XElement.Parse(myElement);
    Console.WriteLine(newElement);
    Console.WriteLine();

    // Load the SimpleInventory.xml file.
    XDocument myDoc = XDocument.Load("SimpleInventory.xml");
    Console.WriteLine(myDoc);
}
```

■ **Source Code** The `ConstructingXmlDocs` example can be found in the [Chapter 24](#) subdirectory.

Manipulating an In-Memory XML Document

So, at this point, you have seen various ways in which LINQ to XML can be used to create, save, parse, and load XML data. The next aspect of LINQ to XML you need to examine is how to navigate a given document to locate and change specific items in the tree using LINQ queries and the LINQ to XML axis methods.

To do so, you will build a Windows Forms application that will display the data within an XML document saved on the hard drive. The GUI will allow the user to enter data for a new node, which will be added to the same XML document. Finally, you will provide a few ways for the user to perform searches on the document, via a handful of LINQ queries.

■ **Note** Given that you have already built a number of LINQ queries in [Chapter 12](#), I won't bother to relist numerous queries here. If you are interested in seeing some additional LINQ to XML examples, look up the topic "Querying XML Trees" in the .NET Framework 4.6 SDK documentation.

Building the UI of the LINQ to XML App

Create a Windows Forms application named `LinqToXmlWinApp` and change the name of your initial `Form1.cs` file to `MainForm.cs` (using the Solution Explorer). The GUI of this window is quite simple. On the left of the window, you have a `TextBox` control (named `txtInventory`), which has the `Multiline` property set to `true` and the `ScrollBars` property set to `Both`.

Beyond that, you have one group of simple `TextBox` controls (`txtMake`, `txtColor`, and `txtPetName`) and a `Button` (`btnAddNewItem`), which will allow the user to add a new entry to the XML document. Finally, you have another group of controls (a `TextBox` named `txtMakeToLookUp` and a final `Button` named `btnLookUpColors`), which allows the user to query the XML document for a set of specified nodes. Figure 24-4 shows one possible layout.

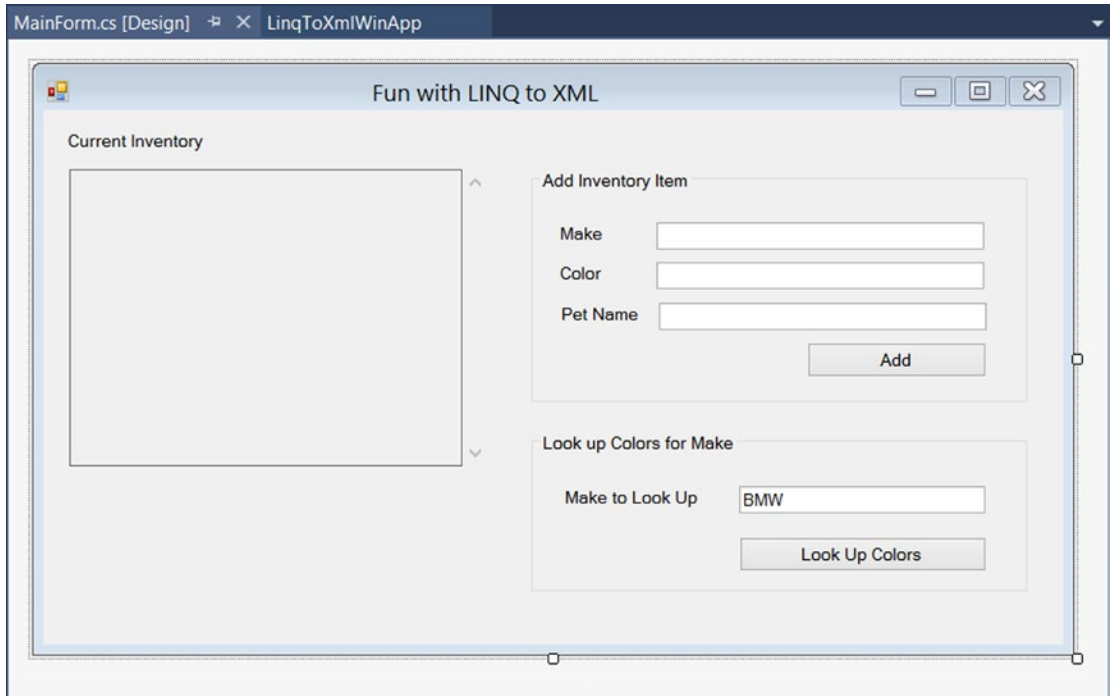

Figure 24-4. The GUI of the LINQ to XML application

Handle the `Click` event for each button to generate the event handler methods. Also handle the `Load` event of the form. You will implement these handlers in a bit, so leave them empty for now.

Import the Inventory.xml File

The downloadable code for this book contains a file named `Inventory.xml` within the solution code for this example. It supports a set of entries within the root `<Inventory>` element. Import this file into your project by selecting the `Project Add Existing Item` menu option. As you look at the data, you will see the root element defines a set of `<Car>` elements, each of which is defined similar to the following:

```
<Car carID = "0">
  <Make>Ford</Make>
  <Color>Blue</Color>
  <PetName>Chuck</PetName>
</Car>
```

Before you continue, be sure you select this file in the Solution Explorer, and then, using the Properties window, set the Copy to Output Directory property to Copy Always. This will ensure the data is deployed to your `\bin\Debug` folder when you compile the application.

Defining a LINQ to XML Helper Class

To isolate the LINQ to XML data, insert a new class to your project named `LinqToXmlObjectModel`. This class will define a set of static methods that encapsulate some LINQ to XML logic. First, define a method that returns a populated `XDocument` based on the contents of the `Inventory.xml` file (be sure to import the `System.Xml.Linq` and `System.Windows.Forms` namespaces into this new file).

```
public static XDocument GetXmlInventory()
{
    try
    {
        XDocument inventoryDoc = XDocument.Load("Inventory.xml");
        return inventoryDoc;
    }
    catch (System.IO.FileNotFoundException ex)
    {
        MessageBox.Show(ex.Message);
        return null;
    }
}
```

The `InsertNewElement()` method (shown in the following) receives the values of the Add Inventory Item `TextBox` controls to place a new node into the `<Inventory>` element using the `Descendants()` axis method. After this is done, you will save the document.

```
public static void InsertNewElement(string make, string color, string petName)
{
    // Load current document.
    XDocument inventoryDoc = XDocument.Load("Inventory.xml");

    // Generate a random number for the ID.
    Random r = new Random();

    // Make new XElement based on incoming parameters.
    XElement newElement = new XElement("Car", new XAttribute("ID", r.Next(50000)),
        new XElement("Color", color),
        new XElement("Make", make),
        new XElement("PetName", petName));

    // Add to in-memory object.
    inventoryDoc.Descendants("Inventory").First().Add(newElement);

    // Save changes to disk.
    inventoryDoc.Save("Inventory.xml");
}
```

The final method, `LookUpColorsForMake()`, will receive the data in the final `TextBox` to build a string that contains the colors of a specified make, using a LINQ query. Consider the following implementation:

```
public static void LookUpColorsForMake(string make)
{
    // Load current document.
    XDocument inventoryDoc = XDocument.Load("Inventory.xml");

    // Find the colors for a given make.
    var makeInfo = from car in inventoryDoc.Descendants("Car")
        where (string)car.Element("Make") == make
        select car.Element("Color").Value;

    // Build a string representing each color.
    string data = string.Empty;
    foreach (var item in makeInfo.Distinct())
    {
        data += string.Format("- {0}\n", item);
    }

    // Show colors.
    MessageBox.Show(data, string.Format("{0} colors:", make));
}
```

Attaching the UI to Your Helper Class

All you need to do at this point is fill in the details of your event handlers. Doing so is as simple as making calls to your static helper methods, like so:

```
public partial class MainForm : Form
{
    public MainForm()
    {
        InitializeComponent();
    }

    private void MainForm_Load(object sender, EventArgs e)
    {
        // Display current XML inventory document in TextBox control.
        txtInventory.Text = LinqToXmlObjectModel.GetXmlInventory().ToString();
    }

    private void btnAddNewItem_Click(object sender, EventArgs e)
    {
        // Add new item to doc.
        LinqToXmlObjectModel.InsertNewElement(txtMake.Text, txtColor.Text, txtPetName.Text);

        // Display current XML inventory document in TextBox control.
        txtInventory.Text = LinqToXmlObjectModel.GetXmlInventory().ToString();
    }
}
```



```
private void btnLookupColors_Click(object sender, EventArgs e)
{
    LinqToXmlObjectModel.LookupColorsForMake(txtMakeToLookup.Text);
}
}
```

Figure 24-5 shows the end result after adding a new auto and looking up all BMWs.

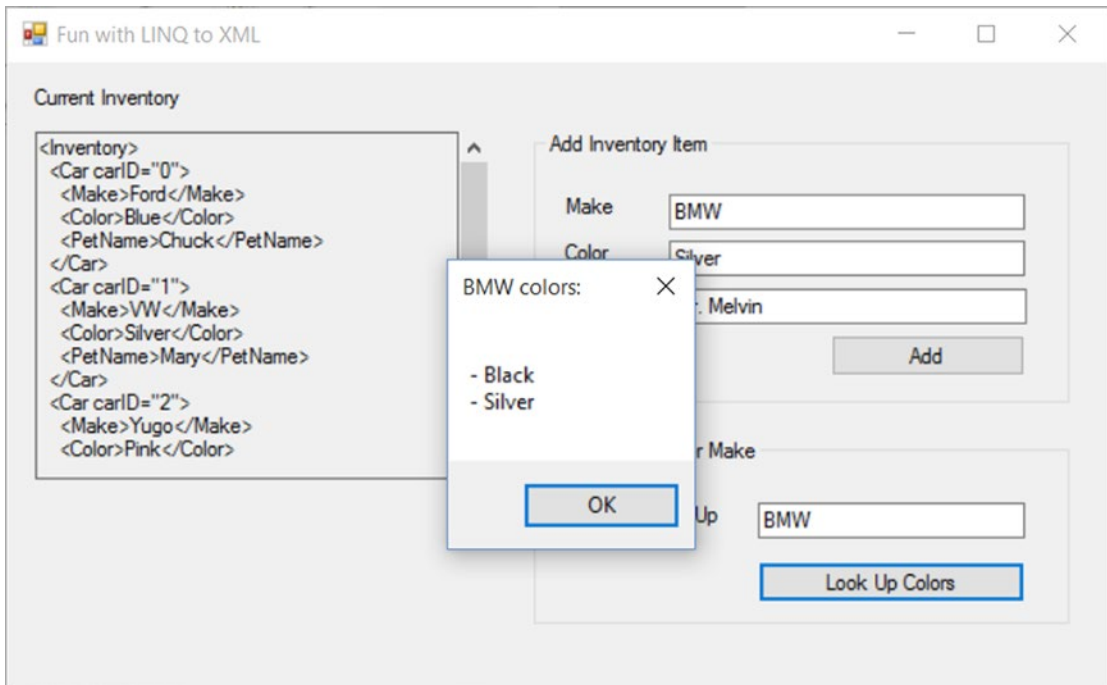

Figure 24-5. The completed LINQ to XML application

That wraps up the introductory look at LINQ to XML and your investigation of LINQ. You first encountered LINQ in Chapter 12, where you learned about LINQ to Objects. Chapter 19 showed various examples using PLINQ, while Chapter 23 showcased how you can apply LINQ queries to ADO.NET Entity objects. Using all this information, you are in good shape to dig deeper, which you should. Microsoft has made it clear that LINQ will continue to evolve as the .NET platform grows.

■ **Source Code** The LinqToXmlWinApp to XML example can be found in the Chapter 24 subdirectory.

Summary

This chapter examined the role of LINQ to XML. As you have seen, this API is an alternative to the initial XML manipulation library, `System.Xml.dll`, which shipped with the .NET platform. Using `System.Xml.Linq.dll`, you are able to generate new XML documents using a top-down approach, where the structure of your code has a striking resemblance to the final XML data. In this light, LINQ to XML is a better DOM. You also learned how to build `XDocument` and `XElement` objects in a variety of ways (parsing, loading from file, mapping from in-memory objects) and how to navigate and manipulate data using LINQ queries.

CHAPTER 25



Introducing Windows Communication Foundation

Windows Communication Foundation (WCF) is the name of the API designed specifically for the process of building distributed systems. Unlike other specific distributed APIs you might have used in the past (e.g., DCOM, .NET remoting, XML web services, message queuing), WCF provides a single, unified, and extendable programming object model that you can use to interact with a number of previously diverse distributed technologies.

This chapter begins by framing the need for WCF and examining the problems it intends to solve by way of a quick review of previous distributed computing APIs. After you look at the services provided by WCF, you'll turn your attention to examining the key .NET assemblies, namespaces, and types that represent this programming model. Over the remainder of this chapter, you'll build several WCF services, hosts, and clients using various WCF development tools.

■ **Note** In this chapter, you will author code that will require that you launch Visual Studio with administrative privileges (furthermore, you must have administrative privileges). To launch Visual Studio with the correct admin rights, right-click the Visual Studio icon and select Run As Administrator.

A Potpourri of Distributed Computing APIs

The Windows operating system has historically provided many APIs for building distributed systems. While it is true that most people consider a *distributed system* to involve at least two networked computers, this term in the broader sense can refer to two executables that need to exchange data, even if they happen to be running on the same physical machine. Using this definition, selecting a distributed API for your current programming task typically involves asking the following pivotal question:

Will this system be used exclusively in house, or will external users require access to the application's functionality?

If you build a distributed system for in-house use, you have a far greater chance of ensuring that each connected computer is running the same operating system and using the same programming framework (e.g., .NET, COM, or the Java platform). Running in-house systems also means that you can leverage your existing security system for purposes of authentication, authorization, and so forth. In this situation, you might

be willing to select a particular distributed API that will tie you to a specific operating system/programming framework for the purposes of performance.

In contrast, if you build a system that others must reach from outside of your walls, you have a whole other set of issues to contend with. First, you will most likely *not* be able to dictate to external users which operating system(s) they can use, which programming framework(s) they can use, or how they configure their security settings.

Second, if you happen to work for a larger company or in a university setting that uses numerous operating systems and programming technologies, an in-house application suddenly faces the same challenges as an outward-facing application. In either of these cases, you need to limit yourself to a more flexible distributed API to ensure the furthest reach of your application.

Based on your answer to this key distributed computing question, the next task is to pinpoint exactly which API (or set of APIs) to use. The following sections provide a quick recap of some of the major distributed APIs historically used by Windows software developers. After you finish this brief history lesson, you will be able to see the usefulness of Windows Communication Foundation quite easily.

■ **Note** To ensure we are on the same page here, I feel compelled to point out that WCF (and the technologies it encompasses) has nothing to do with building an HTML-based web site. While it is true that web applications can be considered distributed because two machines are typically involved in the exchange, WCF is about establishing connections between machines to share the functionality of remote components—not for displaying HTML in a web browser. Chapter 32 will begin your examination of building web sites with the .NET platform.

The Role of DCOM

Prior to the release of the .NET platform, the Distributed Component Object Model (DCOM) was the remoting API of choice for Microsoft-centric development endeavors. Using DCOM, it was possible to build distributed systems using COM objects, the system registry, and a good amount of elbow grease. One benefit of DCOM was that it allowed for *location transparency* of components. Simply put, this allowed you to program client software in such a way that the physical locations of the remote objects were not hard-coded in the application. Regardless of whether the remote object was on the same machine or a secondary networked machine, the code base could remain neutral because the actual location was recorded externally in the system registry.

While DCOM did enjoy some degree of success, for all practical purposes it was a Windows-centric API. DCOM alone did not provide a fabric to build comprehensive solutions involving multiple operating systems (e.g., Windows, Unix, and Mac) or promote sharing of data between diverse architectures (e.g., COM, Java, or CORBA).

■ **Note** There were some attempts to port DCOM to various flavors of Unix/Linux, but the end results were lackluster and eventually became technology footnotes.

By and large, DCOM was best suited for in-house application development because exposing COM objects outside company walls entailed a set of additional complications (firewalls and so forth). With the release of the .NET platform, DCOM quickly became a legacy programming model; and unless you maintain legacy DCOM systems, you can consider it a deprecated technology.

The Role of COM+/Enterprise Services

DCOM alone did little more than define a way to establish a communication channel between two pieces of COM-based software. To fill in the missing pieces required for building a feature-rich distributed computing solution, Microsoft eventually released Microsoft Transaction Server (MTS), which was later renamed to COM+.

Despite its name, COM+ is not used only by COM programmers—it is completely accessible to .NET professionals, as well. Since the first release of the .NET platform, the base class libraries provided a namespace named `System.EnterpriseServices`. Here, .NET programmers could build managed libraries that could be installed into the COM+ runtime to access the same set of services as a traditional COM+-aware COM server. In either case, once a COM+-aware library was installed into the COM+ runtime, it was termed a *serviced component*.

COM+ provides a number of features that serviced components can leverage, including transaction management, object lifetime management, pooling services, a role-based security system, a loosely coupled event model, and so on. This was a major benefit at the time, given that most distributed systems require the same set of services. Rather than forcing developers to code them by hand, COM+ provided an out-of-the-box solution.

One of the compelling aspects of COM+ was that all these settings could be configured in a declarative manner using administrative tools. Thus, if you wanted to ensure an object was monitored under a transactional context or belonged to a particular security role, you simply selected the correct check boxes.

While COM+/Enterprise Services is still in use today, this technology is a Windows-only solution that is best suited for in-house application development or as a back-end service indirectly manipulated by more agonistic front ends (e.g., a public web site that makes calls on serviced components [a.k.a. COM+ objects] in the background).

■ **Note** WCF does not provide a way to build serviced components. However, it does provide a manner for WCF services to communicate with existing COM+ objects. If you need to build serviced components using C#, you will need to make direct use of the `System.EnterpriseServices` namespace. Consult the .NET Framework 4.6 SDK documentation for details.

The Role of MSMQ

The Microsoft Message Queuing (MSMQ) API allows developers to build distributed systems that need to ensure reliable delivery of message data on the network. As developers know all too well, in any distributed system there is the risk that a network server is down, a database is offline, or connections are inexplicably lost. Furthermore, you must construct many applications in such a way that they hold message data for delivery at a later time (this process is known as *queuing data*).

Microsoft initially packaged MSMQ as a set of low-level C-based APIs and COM objects. With the release of the .NET platform, C# programmers could use the `System.Messaging` namespace to hook into MSMQ and build software that communicated with intermittently connected applications in a dependable fashion.

On a related note, the COM+ layer incorporated MSMQ functionality into the runtime (in a simplified format) using a technology termed *Queued Components* (QC). This manner of communicating with MSMQ was packaged up into the `System.EnterpriseServices` namespace mentioned in the previous section.

Regardless of which programming model you used to interact with the MSMQ runtime, the end result ensured that applications could deliver messages in a reliable and timely fashion. Like COM+, MSMQ is still part of the fabric of building distributed software on the Windows operating system.

The Role of .NET Remoting

As mentioned previously, DCOM quickly became a legacy distributed API after the release of the .NET platform. In its place, the .NET base class libraries shipped with the .NET remoting layer, represented by the `System.Runtime.Remoting` namespace. This (now legacy) API allows multiple computers to distribute objects, provided they all run the applications on the .NET platform.

The .NET remoting APIs provided a number of useful features. Most important was the use of XML-based configuration files to define declaratively the underlying plumbing used by the client and the server software. Using *.config files, it was easy to alter the functionality of your distributed system radically simply by changing the content of the configuration files and restarting the application.

Also, given that only .NET applications can use this API, you can gain various performance benefits because data can be encoded in a compact binary format, and you can use the Common Type System (CTS) when defining parameters and return values. While it is possible to use .NET remoting to build distributed systems that span multiple operating systems (using Mono, which was briefly mentioned in Chapter 1), interoperability between other programming architectures (e.g., Java) was still not directly possible.

The Role of XML Web Services

Each of the previous distributed APIs provided little (if any) support to allow external callers to access the supplied functionality in an *agnostic manner*. When you need to expose the services of remote objects to *any* operating system and *any* programming model, XML web services provide a straightforward way of doing so.

Unlike a traditional browser-based web application, a web service provides a way to expose the functionality of remote components using standard web protocols. Since the initial release of .NET, programmers have been provided with superior support for building and consuming XML web services with the `System.Web.Services` namespace. In many cases, building a feature-complete web service is no more complicated than applying the `[WebMethod]` attribute to each public method you want to provide access to. Furthermore, Visual Studio allows you to connect to a remote web service with the click of a button (or two).

Web services allow developers to build .NET assemblies containing types that can be accessed using simple HTTP. Furthermore, a web service encodes its data as simple XML. Given that web services are based on open industry standards (e.g., HTTP, XML, and SOAP) rather than proprietary type systems and proprietary wire formats (as is the case with DCOM or .NET remoting), they allow for a high degree of interoperability and data exchange. Figure 25-1 illustrates the agnostic nature of XML web services.

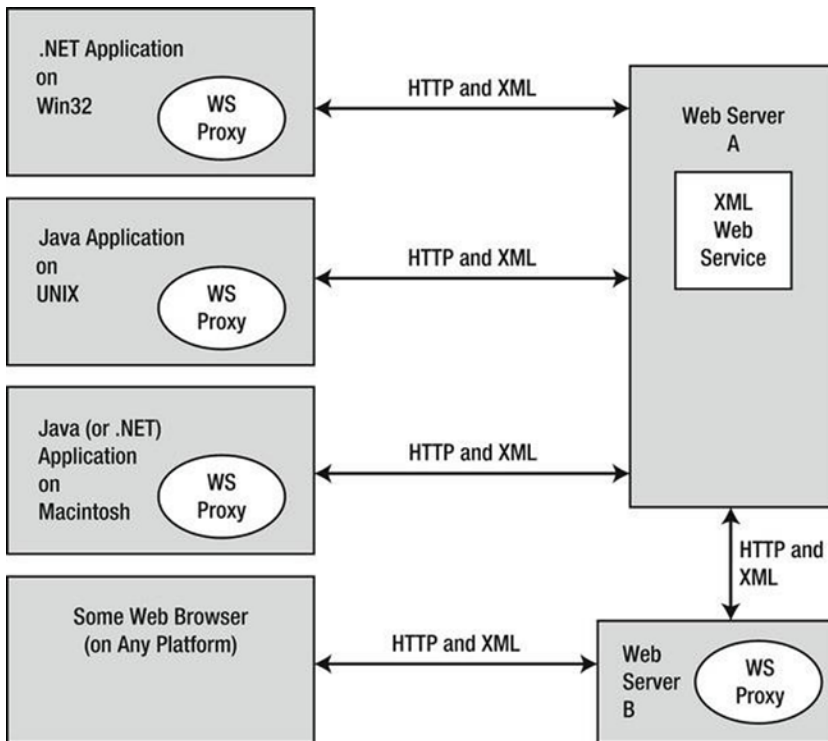

Figure 25-1. XML web services allow for a high degree of interoperability

Of course, no distributed API is perfect. One potential drawback of web services is that they can suffer from some performance issues (given the use of HTTP and XML data representation). Another drawback is that they might not be an ideal solution for in-house applications where you could use a TCP-based protocol and binary formatting of data without incurring a penalty.

Web Service Standards

Another problem that web services faced early on was that all the big industry players (e.g., Microsoft, IBM, and Sun Microsystems) created web service implementations that were not 100 percent compatible with other web service implementations. Obviously, this was an issue because the whole point of web services is to achieve a high degree of interoperability across platforms and operating systems!

To ensure the interoperability of web services, groups such as the World Wide Web Consortium (W3C: www.w3.org) and the Web Services Interoperability Organization (WS-I: www.ws-i.org) began to author several specifications that laid out how a software vendor (e.g., IBM, Microsoft, or Sun Microsystems) should build web service–centric software libraries to ensure compatibility.

Collectively, all these specifications are given the blanket name WS-*, and they cover such issues as security, attachments, the description of web services (using the *Web Service Description Language*, or *WSDL*), policies, SOAP formats, and a slew of other important details. As you will see, WCF supports many of these WS-* specifications. Typically, your WCF services will opt into various WS-* specifications based on your choice of *bindings*.

■ **Note** In addition to the distributed APIs briefly examined, developers could also use various interprocess communication protocols such as named pipes and sockets.

The Role of WCF

The wide array of distributed technologies makes it difficult to pick the right tool for the job. This is further complicated by the fact that several of these technologies overlap in the services they provide (most notably in the areas of transactions and security).

Even when a .NET developer has selected what appear to be the correct technologies for the task at hand, building, maintaining, and configuring such an application is complex, at best. Each API has its own programming model, its own unique set of configuration tools, and so forth. Prior to WCF, this meant that it was difficult to plug and play distributed APIs without authoring a considerable amount of custom infrastructure. For example, if you build your system using the .NET remoting APIs and you later decide that XML web services are a more appropriate solution, you need to reengineer your code base.

WCF is a distributed computing toolkit that integrates these previously independent distributed technologies into a streamlined API represented primarily by the `System.ServiceModel` namespace. Using WCF, you can expose services to callers using a wide variety of techniques. For example, if you build an in-house application where all connected machines are Windows-based, you can use various TCP protocols to ensure the fastest possible performance. You can also expose this same service with HTTP and SOAP to allow external callers to leverage its functionality, regardless of the programming language or operating system.

Given that WCF allows you to pick the correct protocol for the job (using a common programming model), you will find that it becomes quite easy to plug and play the underlying plumbing of your distributed application. In most cases, you can do so without having to recompile or redeploy the client/service software because the gungui details are often relegated to application configuration files.

An Overview of WCF Features

Interoperability and integration of diverse APIs are only two (important) aspects of WCF. WCF also provides a rich software fabric that complements the remoting technologies it exposes. Consider the following list of major WCF features:

- Support for strongly typed *as well as* untyped messages. This approach allows .NET applications to share custom types efficiently, while software created using other platforms (such as Java) can consume streams of loosely typed XML.
- Support for several *bindings* (e.g., raw HTTP, TCP, MSMQ, WebSockets, named pipes, and so on) allows you to choose the most appropriate plumbing to transport message data.
- Support for the latest-and-greatest web service specifications (WS-*).
- A fully integrated security model encompassing both native Windows/.NET security protocols and numerous neutral-security techniques built on web service standards.
- Support for session-like state management techniques, as well as support for one-way or stateless messages.

As impressive as this list of features might be, it only scratches the surface of the functionality WCF provides. WCF also offers tracing and logging facilities, performance counters, a publish-and-subscribe event model, and transactional support, among other features.

An Overview of Service-Oriented Architecture

Yet another benefit of WCF is that it is based on the design principles established by *service-oriented architecture* (SOA). To be sure, SOA is a major buzzword in the industry; and like most buzzwords, SOA can be defined in numerous ways. Simply put, SOA is a way to design a distributed system where several autonomous *services* work in conjunction by passing *messages* across boundaries (either networked machines or two processes on the same machine) using well-defined *interfaces*.

In the world of WCF, you typically create these well-defined interfaces using CLR interface types (see Chapter 9). In a more general sense, however, the interface of a service simply describes the set of members that might be invoked by external callers.

The team that designed WCF observed the four tenets of SOA design principles. While these tenets are typically honored automatically simply by building a WCF application, understanding these four cardinal design rules of SOA can help you understand WCF better. The sections that follow provide a brief overview of each tenet.

Tenet 1: Boundaries are Explicit

This tenet reiterates that the functionality of a WCF service is expressed using well-defined interfaces (e.g., descriptions of each member, its parameters, and its return values). The only way that an external caller can communicate with a WCF service is through the interface, and the external caller remains blissfully unaware of the underlying implementation details.

Tenet 2: Services are Autonomous

The term *autonomous entities* refers to the fact that a given WCF service is (as much as possible) an island unto itself. An autonomous service should be independent with regard to version, deployment, and installation issues. To help promote this tenet, you can fall back on a key aspect of interface-based programming. Once an interface is in production, it should never be changed (or you will risk breaking existing clients). When you need to extend the functionality of your WCF service, you author new interfaces that model the desired functionality.

Tenet 3: Services Communicate via Contract, Not Implementation

The third tenet is yet another by-product of interface-based programming. The implementation details of a WCF service (e.g., the language it was written in, how it accomplishes its work, etc.) are of no concern to the external caller. WCF clients interact with services solely through their exposed public interfaces.

Tenet 4: Service Compatibility is Based on Policy

Because CLR interfaces provide strongly typed contracts for all WCF clients (and can also be used to generate a related WSDL document based on your choice of binding), it is important to realize that interfaces and WSDL alone are not expressive enough to detail aspects of what the service is capable of doing. Given this, SOA allows you to define *policies* that further qualify the semantics of the service (e.g., the expected security requirements used to talk to the service). Using these policies, you can basically separate the low-level syntactic description of your service (the exposed interfaces) from the semantic details of how they work and how they need to be invoked.

WCF: The Bottom Line

The preceding short history lesson explains why WCF is the preferred approach for building distributed applications. WCF is the recommended API whether you want to build an in-house application using TCP protocols, move data between programs on the same machine using named pipes, or expose data to the world at large using HTTP-based protocols.

This is not to say that you cannot use the original .NET distributed-centric namespaces (e.g., `System.Runtime.Remoting`, `System.Messaging`, `System.EnterpriseServices`, and `System.Web.Services`) in new development efforts. In some cases (e.g., if you need to build COM+ objects), you must do so. In any case, if you have used these APIs in previous projects, you will find learning WCF straightforward. Like the technologies that preceded it, WCF makes considerable use of XML-based configuration files, .NET attributes, and proxy generation utilities.

With this introductory foundation behind you, you can concentrate on the topic of building WCF applications. Again, you should understand that full coverage of WCF would require an entire book because each of the supported services (e.g., MSMQ, COM+, P2P, and named pipes) could be a chapter unto itself. Here, you will learn the overall process of building WCF programs using both TCP- and HTTP-based (e.g., web service) protocols. This should put you in a good position to study these topics further, as you see fit.

Investigating the Core WCF Assemblies

As you might expect, the programming fabric of WCF is represented by a set of .NET assemblies installed into the GAC. Table 25-1 describes the overall role of the core WCF assemblies you need to use in just about any WCF application.

Table 25-1. Core WCF Assemblies

| Assembly | Meaning in Life |
|---|--|
| <code>System.Runtime.Serialization.dll</code> | This core assembly defines namespaces and types that you can use for serializing and deserializing objects in the WCF framework. |
| <code>System.ServiceModel.dll</code> | This core assembly contains the types used to build any sort of WCF application. |

The two assemblies listed in Table 25-1 define many new namespaces and types. You should consult the .NET Framework 4.6 SDK documentation for complete details; however, Table 25-2 documents the roles of some of the important namespaces.

Table 25-2. Core WCF Namespaces

| Namespace | Meaning in Life |
|-------------------------------------|---|
| System.Runtime.Serialization | This defines many types you use to control how data is serialized and deserialized within the WCF framework. |
| System.ServiceModel | This primary WCF namespace defines binding and hosting types, as well as basic security and transactional types. |
| System.ServiceModel.Configuration | This defines numerous types that provide programmatic access to WCF configuration files. |
| System.ServiceModel.Description | This defines types that provide an object model to the addresses, bindings, and contracts defined within WCF configuration files. |
| System.ServiceModel.MsmqIntegration | This contains types to integrate with the MSMQ service. |
| System.ServiceModel.Security | This defines numerous types to control aspects of the WCF security layers. |

The Visual Studio WCF Project Templates

As will be explained in more detail later in this chapter, a WCF application is typically represented by three interrelated assemblies, one of which is a *.dll that contains the types that external callers can communicate with (in other words, the WCF service itself). When you want to build a WCF service, it is perfectly permissible to select a standard Class Library project template (see Chapter 14) as a starting point and manually reference the WCF assemblies.

Alternatively, you can create a new WCF service by selecting the WCF Service Library project template of Visual Studio (see Figure 25-2). This project type automatically sets references to the required WCF assemblies; however, it also generates a good deal of starter code, which you will likely often delete.

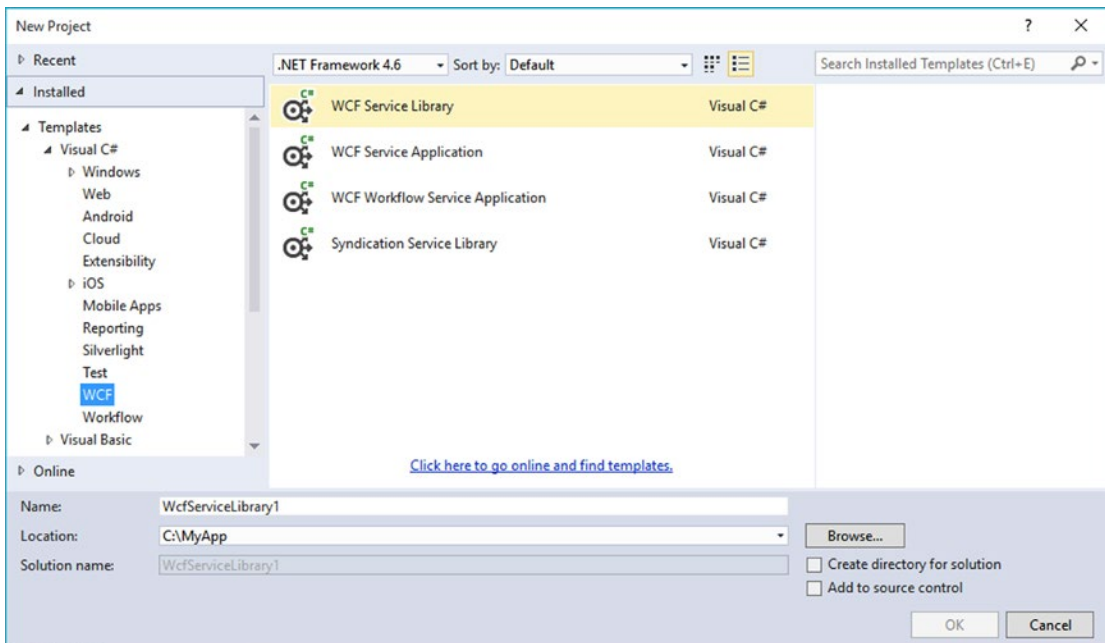

Figure 25-2. The Visual Studio WCF Service Library project template

One benefit of selecting the WCF Service Library project template is that it also supplies you with an `App.config` file, which might seem strange because you are building a `.NET *.dll`, not a `.NET *.exe`. However, this file is useful because when you debug or run your WCF Service Library project, the Visual Studio IDE will automatically launch the WCF Test Client application. This program (`WcfTestClient.exe`) will look up the settings in the `App.config` file, so it can host your service for testing purposes. You'll learn more about the WCF Test Client later in this chapter.

■ **Note** The `App.config` file of the WCF Service Library project is also useful because it shows you the bare-bones settings used to configure a WCF host application. In fact, you can copy and paste much of this code into the configuration file of your production services.

In addition to the basic WCF Service Library template, the WCF project category of the New Project dialog box defines a WCF library project that integrates Windows Workflow Foundation (WF) functionality into a WCF service, as well as a template to build an RSS library (see Figure 25-2).

The WCF Service Web Site Project Template

You can find yet another Visual Studio WCF-centric project template in the New Web Site dialog box, which you activate using the `File > New > Web Site` menu option (see Figure 25-3).

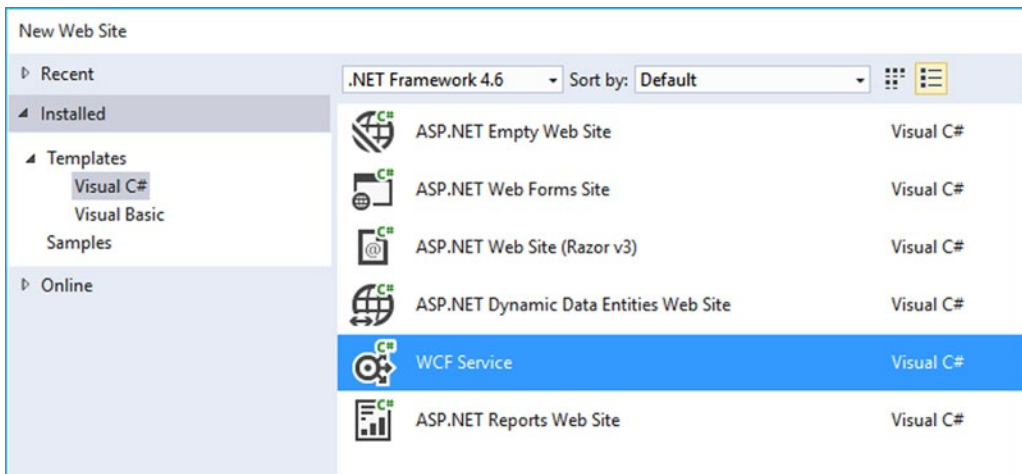

Figure 25-3. The Visual Studio web-based WCF Service project template

This WCF Service project template is useful when you know from the outset that your WCF service will use HTTP-based protocols rather than, for example, TCP or named pipes. This option can automatically create a new Internet Information Services (IIS) virtual directory to contain your WCF program files, create a proper `Web.config` file to expose the service through HTTP, and author the necessary `*.svc` file (you'll learn more about `*.svc` files later in this chapter). Thus, the web-based WCF Service project is a time-saver because the IDE automatically sets up the required IIS infrastructure.

In contrast, if you build a new WCF service using the WCF Service Library option, you have the ability to host the service in a variety of ways (e.g., custom host, Windows service, or manually built IIS virtual directory). This option is more appropriate when you need to build a custom host for your WCF service that can work with any number of WCF bindings.

The Basic Composition of a WCF Application

When you build a WCF distributed system, you will typically do so by creating the following three interrelated assemblies:

- *The WCF Service assembly:* This `*.dll` contains the classes and interfaces that represent the overall functionality you want to expose to external callers.
- *The WCF Service host:* This software module is the entity that hosts your WCF service assembly.
- *The WCF client:* This is the application that accesses the service's functionality through an intervening proxy.

As mentioned previously, the WCF Service assembly is a .NET class library that contains a number of WCF contracts and their implementations. The key difference is that the interface contracts are adorned with various attributes that control data type representation, how the WCF runtime interacts with the exposed types, and so forth.

The second assembly, the WCF Service host, can be literally any .NET executable. As you will see later in this chapter, WCF was set up so that you can expose services easily from any type of application (e.g., Windows Forms, a Windows service, and WPF applications). When you build a custom host, you use the `ServiceHost` type and possibly a related `*.config` file. The latter contains details regarding the server-side

plumbing you want to use. However, if you use IIS as the host for your WCF service, you don't need to build a custom host programmatically because IIS will use the `ServiceHost` type behind the scenes.

■ **Note** It is also possible to host a WCF service using the Windows Activation Service (WAS); you can consult the .NET Framework 4.6 SDK documentation for details.

The final assembly represents the client that makes calls into the WCF service. As you might expect, this client can be any type of .NET application. Similar to the host, client applications typically use a client-side `*.config` file that defines the client-side plumbing. You should also be aware that you can easily have a client application written in another framework (e.g., Java) if you build your WCF service using HTTP-based bindings.

Figure 25-4 illustrates the relationship between these three interrelated WCF assemblies (from a high level). Behind the scenes, several lower-level details are used to represent the required plumbing (e.g., factories, channels, and listeners). These low-level details are usually hidden from view; however, they can be extended or customized if required. In most cases, the default plumbing fits the bill sufficiently.

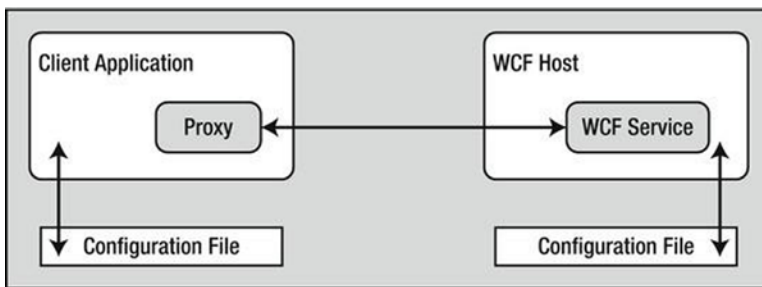

Figure 25-4. A high-level look at a typical WCF application

It is also worth pointing out that using a server-side or client-side `*.config` file is technically optional. If you want, you can hard-code the host (as well as the client) to specify the necessary plumbing (e.g., endpoints, binding, and addresses). The obvious problem with this approach is that if you need to change the plumbing details, you will need to recode, recompile, and redeploy a number of assemblies. Using a `*.config` file keeps your code base much more flexible because changing the plumbing is as simple as updating the file's content and restarting the application. On the other hand, programmatic configuration allows an application more dynamic flexibility—it can choose how to configure the plumbing based on *if-tests*, for example.

The ABCs of WCF

Hosts and clients communicate with each other by agreeing on the ABCs, a friendly mnemonic for remembering the core building blocks of a WCF application *address*, *binding*, and *contract*, defined as follows:

- *Address*: Describes the location of the service. In code, you represent this with a `System.Uri` type; however, you typically store the value in `*.config` files.
- *Binding*: WCF ships with a many different bindings that specify network protocols, encoding mechanisms, and the transport layer.
- *Contract*: Provides a description of each method exposed from the WCF service.

You should realize that the ABC abbreviation does not imply that a developer must define the address first, followed by binding, and ending with the contract. In many cases, a WCF developer begins by defining a contract for the service, followed by establishing an address and bindings (any order will do, as long as each aspect is accounted for). Before you move on to building your first WCF application, let's take a more detailed look at the ABCs.

Understanding WCF Contracts

Understanding the notion of a *contract* is the key to building a WCF service. While not mandatory, the vast majority of your WCF applications will begin by defining a set of .NET interface types that are used to represent the set of members a given WCF service will support. Specifically, interfaces that represent a WCF contract are called *service contracts*. The classes (or structures) that implement them are called *service types*.

WCF service contracts are adorned with various attributes, the most common of which are defined in the `System.ServiceModel` namespace. When the members of a service contract (the methods in the interface) contain only simple data types (e.g., numerical data, Booleans, and string data), you can build a complete WCF service using nothing more than the `[ServiceContract]` and `[OperationContract]` attributes.

However, if your members expose custom types, you will likely use various types in the `System.Runtime.Serialization` namespace (see Figure 25-5) of the `System.Runtime.Serialization.dll` assembly. Here you will find additional attributes (e.g., `[DataMember]` and `[DataContract]`) to fine-tune the process of defining how your composite types are serialized to and from XML when they are passed to and from service operations.

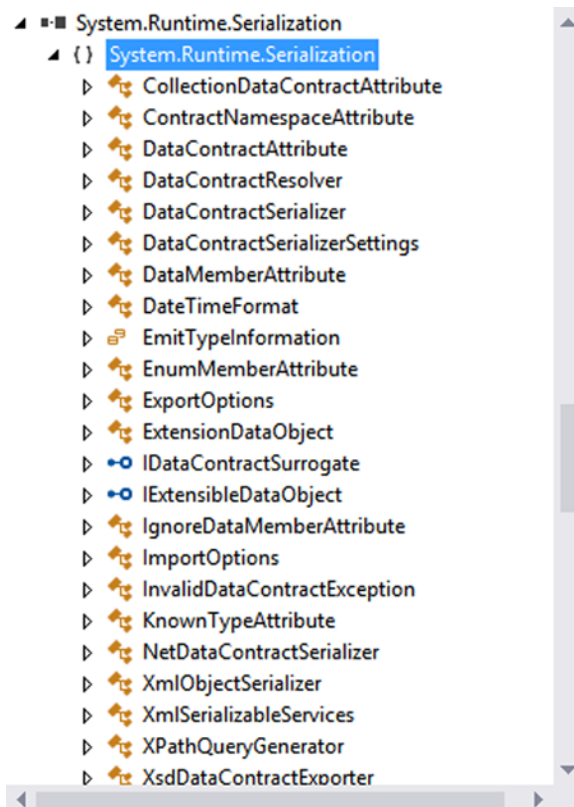

Figure 25-5. `System.Runtime.Serialization` defines a number of attributes used when building WCF data contracts

Strictly speaking, you are not required to use CLR interfaces to define a WCF contract. Many of these same attributes can be applied on public members of a public class (or structure). However, given the many benefits of interface-based programming (e.g., polymorphism and elegant versioning), it is safe to consider that using CLR interfaces to describe a WCF contract is a best practice.

Understanding WCF Bindings

Once you define and implement a contract (or a set of contracts) in your service library, the next logical step is to build a hosting agent for the WCF service itself. As mentioned previously, you have a variety of possible hosts to choose from, all of which must specify the *bindings* used by remote callers to gain access to the service type's functionality.

WCF ships with many of binding choices, each of which is tailored to a specific need. If none of the out-of-the-box bindings fits the bill, you can create your own by extending the `CustomBinding` type (something you will not do in this chapter). A WCF binding can specify the following characteristics:

- The transport layer used to move data (HTTP, MSMQ, named pipes, REST, WebSockets, and TCP)
- The channels used by the transport (one-way, request-reply, and duplex)
- The encoding mechanism used to deal with the data itself (e.g., XML and binary)
- Any supported web service protocols (if permitted by the binding), such as WS- Security, WS-Transactions, WS-Reliability, and so on

Let's take a look at your basic choices.

HTTP-Based Bindings

The `BasicHttpBinding`, `WSHttpBinding`, `WSDualHttpBinding`, and `WSFederationHttpBinding` options are geared toward exposing contract types through HTTP/SOAP protocols. If you require the furthest reach possible for your service (e.g., multiple operating systems and multiple programming architectures), you want to focus on these bindings because all of these binding types encode data based on XML representation and use HTTP on the wire.

Table 25-3 shows how you can represent a WCF binding in code (using class types within the `System.ServiceModel` namespace) or as XML attributes defined within `*.config` files.

Table 25-3. *The HTTP-Centric WCF Bindings*

| Binding Class | Binding Element | Meaning in Life |
|-------------------------|---------------------------|--|
| BasicHttpBinding | <basicHttpBinding> | You use this to build a WS-Basic Profile-conformant (WS-I Basic Profile 1.1) WCF service. This binding uses HTTP as the transport and Text/XML as the default message encoding. |
| WSHttpBinding | <wsHttpBinding> | This is similar to BasicHttpBinding but provides more web service features. This binding adds support for transactions, reliable messaging, and WS-Addressing. |
| WSDualHttpBinding | <wsDualHttpBinding> | This is similar to WSHttpBinding but intended for use with duplex contracts (e.g., the service and client can send messages back and forth). This binding supports only SOAP security and requires reliable messaging. |
| WSFederationHttpBinding | <wsFederationHttpBinding> | This is a secure and interoperable binding that supports the WS- Federation protocol, enabling organizations that are in a federation to authenticate and authorize users efficiently. |

As its name suggests, `BasicHttpBinding` is the simplest of all web service-centric protocols. Specifically, this binding ensures that your WCF service conforms to a specification named WS-I Basic Profile 1.1 (defined by WS-I). The main reason to use this binding is for maintaining backward compatibility with applications that were previously built to communicate with ASP.NET web services (which have been part of the .NET libraries since version 1.0).

The `WSHttpBinding` protocol not only incorporates support for a subset of the WS-* specification (transactions, security, and reliable sessions) but also supports the ability to handle binary data encoding using Message Transmission Optimization Mechanism (MTOM).

The main benefit of `WSDualHttpBinding` is that it adds the ability to allow the caller and sender to communicate using *duplex messaging*, which is a fancy way of saying they can engage in a two-way conversation. When selecting `WSDualHttpBinding`, you can hook into the WCF publish/subscribe event model.

Finally, `WSFederationHttpBinding` is the web service-based protocol you might want to consider when security among a group of organizations is of the utmost importance. This binding supports the WS-Trust, WS-Security, and WS-SecureConversation specifications, which are represented by the WCF CardSpace APIs.

TCP-Based Bindings

If you build a distributed application involving machines that are configured with the .NET 4.5 libraries (in other words, all machines are running the Windows operating system), you can gain performance benefits by bypassing web service bindings and opting for a TCP binding, which ensures that all data is encoded in a compact binary format, rather than XML. Again, when you use the bindings shown in Table 25-4, the client and host must be .NET applications.

Table 25-4. *The TCP-Centric WCF Bindings*

| Binding Class | Binding Element | Meaning in Life |
|---------------------|-----------------------|---|
| NetNamedPipeBinding | <netNamedPipeBinding> | Serves as a secure, reliable, optimized binding for on-the-same-machine communication between .NET applications |
| NetPeerTcpBinding | <netPeerTcpBinding> | Provides a secure binding for P2P network applications |
| NetTcpBinding | <netTcpBinding> | Serves as a secure and optimized binding suitable for cross-machine communication between .NET applications |

The `NetTcpBinding` class uses TCP to move binary data between the client and WCF service. As mentioned previously, this will result in higher performance than the web service protocols but limits you to an in-house Windows solution. On the plus side, `NetTcpBinding` supports transactions, reliable sessions, and secure communications.

Like `NetTcpBinding`, `NetNamedPipeBinding` supports transactions, reliable sessions, and secure communications; however, it has no ability to make cross-machine calls. If you want to find the fastest way to push data between WCF applications on the same machine (e.g., cross-application domain communications), `NetNamedPipeBinding` is the binding choice of champions. For more information on `NetPeerTcpBinding`, consult the .NET Framework 4.6 SDK documentation for details regarding P2P networking.

MSMQ-Based Bindings

Finally, the `NetMsmqBinding` and `MsmqIntegrationBinding` bindings are of immediate interest if you want to integrate with a Microsoft MSMQ server. This chapter will not examine the details of using MSMQ bindings, but Table 25-5 documents the basic role of each.

Table 25-5. *The MSMQ-Centric WCF Bindings*

| Binding Class | Binding Element | Meaning in Life |
|-------------------------------------|--------------------------|--|
| <code>MsmqIntegrationBinding</code> | <msmqIntegrationBinding> | You can use this binding to enable WCF applications to send and receive messages to and from existing MSMQ applications that use COM, native C++, or the types defined in the <code>System.Messaging</code> namespace. |
| <code>NetMsmqBinding</code> | <netMsmqBinding> | You can use this queued binding for cross-machine communication between .NET applications. This is the preferred approach among the MSMQ-centric bindings. |

Understanding WCF Addresses

Once you establish the contracts and bindings, the final piece of the puzzle is to specify an *address* for the WCF service. This is important because remote callers will be unable to communicate with the remote types if they cannot locate them! Like most aspects of WCF, an address can be hard-coded in an assembly (using the `System.Uri` type) or offloaded to a `*.config` file.

In either case, the exact format of the WCF address will differ based on your choice of binding (HTTP based, named pipes, TCP based, or MSMQ based). From a high level, WCF addresses can specify the following bits of information:

- **Scheme:** The transport protocol (e.g., HTTP)
- **MachineName:** The fully qualified domain of the machine
- **Port:** This is optional in many cases; for example, the default for HTTP bindings is port 80.
- **Path:** The path to the WCF service

This information can be represented by the following generalized template (the `Port` value is optional because some bindings don't use them):

```
scheme://<MachineName>[:Port]/Path
```

When you use an HTTP-based binding (e.g., `basicHttpBinding`, `wsHttpBinding`, `wsDualHttpBinding`, or `wsFederationHttpBinding`), the address breaks down like this (recall that HTTP-based protocols default to port 80 if you do not specify a port number):

```
http://localhost:8080/MyWCFService
```

If you use TCP-centric bindings (e.g., `NetTcpBinding` or `NetPeerTcpBinding`), the URI takes the following format:

```
net.tcp://localhost:8080/MyWCFService
```

The MSMQ-centric bindings (`NetMsmqBinding` and `MsmqIntegrationBinding`) are unique in their URI format because MSMQ can use public or private queues (which are available only on the local machine), and port numbers have no meaning in an MSMQ-centric URI. Consider the following URI, which describes a private queue named `MyPrivateQ`:

```
net.msmq://localhost/private$/MyPrivateQ
```

Last but not least, the address format used for the named-pipe binding, `NetNamedPipeBinding`, breaks down like this (recall that named pipes allow for interprocess communication for applications on the same physical machine):

```
net.pipe://localhost/MyWCFService
```

While a single WCF service might expose only a single address (based on a single binding), it is possible to configure a collection of unique addresses (with different bindings). You can do this in a `*.config` file by defining multiple `<endpoint>` elements. Here, you can specify any number of ABCs for the same service. This approach can be helpful when you want to allow callers to select which protocol they would like to use when communicating with the service.

Building a WCF Service

Now that you have a better understanding about the building blocks of a WCF application, it's time to create your first sample application and see how the ABCs are accounted for in code and configuration. This first example avoids using the Visual Studio WCF project templates, so you can focus on the specific steps involved in making a WCF service.

Begin by creating a new C# Class Library project named `MagicEightBallServiceLib`. Next, rename your initial file from `Class1.cs` to `MagicEightBallService.cs` and then add a reference to the `System.ServiceModel.dll` assembly. In the initial code file, specify that you are using the `System.ServiceModel` namespace. At this point, your C# file should look like this (note you have a public class at this point):

```
// The key WCF namespace.
using System.ServiceModel;

namespace MagicEightBallServiceLib
{
    public class MagicEightBallService
    {
    }
}
```

Your class type implements a single WCF service contract represented by a strongly typed CLR interface named `IEightBall`. As you most likely know, the Magic 8-Ball is a toy that allows you to view one of a handful of fixed answers to a question you might ask. Your interface here will define a single method that allows the caller to pose a question to the Magic 8-Ball to obtain a random answer.

WCF service interfaces are adorned with the `[ServiceContract]` attribute, while each interface member is decorated with the `[OperationContract]` attribute (you'll learn more details regarding these two attributes in just a moment). Here is the definition of the `IEightBall` interface:

```
[ServiceContract]
public interface IEightBall
{
    // Ask a question, receive an answer!
    [OperationContract]
    string ObtainAnswerToQuestion(string userQuestion);
}
```

■ **Note** It is permissible to define a service contract interface that contains methods not adorned with the `[OperationContract]` attribute; however, such members will not be exposed through the WCF runtime.

As you know from your study of the interface type (see Chapter 8), interfaces are quite useless until they are implemented by a class or structure that fleshes out their functionality. Like a real Magic 8-Ball, the implementation of your service type (`MagicEightBallService`) will randomly return a canned answer from an array of strings. Also, your default constructor will display an information message that will be (eventually) displayed within the host's console window (for diagnostic purposes).

```

public class MagicEightBallService : IEightBall
{
    // Just for display purposes on the host.
    public MagicEightBallService()
    {
        Console.WriteLine("The 8-Ball awaits your question...");
    }

    public string ObtainAnswerToQuestion(string userQuestion)
    {
        string[] answers = { "Future Uncertain", "Yes", "No",
            "Hazy", "Ask again later", "Definitely" };

        // Return a random response.
        Random r = new Random();
        return answers[r.Next(answers.Length)];
    }
}

```

At this point, your WCF Service Library is complete. However, before you construct a host for this service, you need to examine some additional details of the [ServiceContract] and [OperationContract] attributes.

The [ServiceContract] Attribute

For a CLR interface to participate in the services provided by WCF, it must be adorned with the [ServiceContract] attribute. Like many other .NET attributes, the ServiceContractAttribute type supports many properties that further qualify its intended purpose. You can set two properties, Name and Namespace, to control the name of the service type and the name of the XML namespace that defines the service type. If you use an HTTP-specific binding, you use these values to define the <portType> elements of the related WSDL document.

Here, you do not bother to assign a Name value because the default name of the service type is directly based on the C# class name. However, the default name for the underlying XML namespace is simply <http://tempuri.org> (you should change this for all your WCF services).

When you build a WCF service that will send and receive custom data types (which you are not currently doing), it is important that you establish a meaningful value to the underlying XML namespace because this ensures that your custom types are unique. As you might know from your experience building XML web services, XML namespaces provide a way to wrap your custom types in a unique container to ensure that your types do not clash with types in another organization.

For this reason, you can update your interface definition with a more fitting definition, which, much like the process of defining an XML namespace in a .NET Web Service project, is typically the URI of the service's point of origin, as in the following example:

```

[ServiceContract(Namespace = "http://MyCompany.com")]
public interface IEightBall
{
    ...
}

```

Beyond Namespace and Name, the [ServiceContract] attribute can be configured with the additional properties shown in Table 25-6. Be aware that some of these settings will be ignored, depending on your binding selection.

Table 25-6. Various Named Properties of the [ServiceContract] Attribute

| Property | Meaning in Life |
|-------------------|---|
| CallbackContract | Establishes whether this service contract requires callback functionality for two-way message exchange (e.g., duplex bindings). |
| ConfigurationName | Locates the service element in an application configuration file. The default is the name of the service implementation class. |
| ProtectionLevel | Allows you to specify the degree to which the contract binding requires encryption, digital signatures, or both for endpoints that expose the contract. |
| SessionMode | Establishes whether sessions are allowed, not allowed, or required by this service contract. |

The [OperationContract] Attribute

Methods that you intend to use within the WCF framework must be attributed with the [OperationContract] attribute, which can also be configured with various named properties. You can use the properties shown in Table 25-7 to declare that a given method is intended to be one-way in nature, supports asynchronous invocation, requires encrypted message data, and so forth (again, many of these values might be ignored based on your binding selection).

Table 25-7. Various Named Properties of the [OperationContract] Attribute

| Property | Meaning in Life |
|---------------|--|
| AsyncPattern | Indicates whether the operation is implemented asynchronously using a Begin/End method pair on the service. This allows the service to offload processing to another server-side thread; this has nothing to do with the client calling the method asynchronously! |
| IsInitiating | Specifies whether this operation can be the initial operation in a session. |
| IsOneWay | Indicates whether the operation consists of only a single input message (and no associated output). |
| IsTerminating | Specifies whether the WCF runtime should attempt to terminate the current session after the operation completes. |

For the initial example, you don't need to configure the `ObtainAnswerToQuestion()` method with additional traits; this means you can use the [OperationContract] attribute as currently defined.

Service Types As Operational Contracts

Finally, recall that the use of interfaces is not required when building WCF service types. In fact, it is possible to apply the [ServiceContract] and [OperationContract] attributes directly to the service type itself, like so:

```
// This is only for illustrative purposes
// and not used for the current example.
[ServiceContract(Namespace = "http://MyCompany.com")]
public class ServiceTypeAsContract
```

```

{
    [OperationContract]
    void SomeMethod() { }

    [OperationContract]
    void AnotherMethod() { }
}

```

You can take this approach; however, you receive many benefits if you explicitly define an interface type to represent the service contract. The most obvious benefit is that you can apply a given interface to multiple service types (authored in a variety of languages and architectures) to achieve a high degree of polymorphism. Another benefit is that you can use a service contract interface as the basis of new contracts (using interface inheritance), without having to carry any implementation baggage.

In any case, your first WCF Service Library is now complete. Compile your project to ensure you do not have any typos.

■ **Source Code** You can find the `MagicEightBallServiceLib` project in the `MagicEightBallServiceHTTP` subdirectory of Chapter 25.

Hosting the WCF Service

You are now ready to define a host. Although you would host a production-level service from a Windows service or an IIS virtual directory, you will make your first host a simple console named `MagicEightBallServiceHost`.

After you create this new Console Application project, add a reference to the `System.ServiceModel.dll` and `MagicEightBallServiceLib.dll` assemblies, and then update your initial code file by importing the `System.ServiceModel` and `MagicEightBallServiceLib` namespaces, like so:

```

using System;
...

using System.ServiceModel;
using MagicEightBallServiceLib;

namespace MagicEightBallServiceHost
{
    class Program
    {
        static void Main(string[] args)
        {
            Console.WriteLine("***** Console Based WCF Host *****");
            Console.ReadLine();
        }
    }
}

```

The first step you must take when building a host for a WCF service type is to decide whether you want to define the necessary hosting logic completely in code or to relegate several low-level details to an application configuration file. As mentioned previously, the benefit of *.config files is that the host can change the underlying plumbing without requiring you to recompile and redeploy the executable. However, always remember this is strictly optional because you can hard-code the hosting logic using the types within the System.ServiceModel.dll assembly.

This console-based host will use an application configuration file, so insert this new file (if your project does not currently have one) into your current project by using the Project ► Add New Item menu option and then choosing Application Configuration File.

Establishing the ABCs Within an App.config File

When you build a host for a WCF service type, you follow a predictable set of steps—some that rely on configuration and some that rely on code. These steps are as follows:

- Define the *endpoint* for the WCF service being hosted within the host's configuration file.
- Programmatically use the ServiceHost type to expose the service types available from this endpoint.
- Ensure the host remains running to service incoming client requests. Obviously, this step is not required if you host your service types using a Windows service or IIS.

In the world of WCF, the term *endpoint* represents the address, binding, and contract rolled together in a nice, tidy package. In XML, an endpoint is expressed using the <endpoint> element and the address, binding, and contract elements. Update your *.config file to specify a single endpoint (reachable through port 8080) exposed by this host, like so:

```
<?xml version = "1.0" encoding = "utf-8" ?>
<configuration>
  <system.serviceModel>
    <services>
      <service name = "MagicEightBallServiceLib.MagicEightBallService">
        <endpoint address = "http://localhost:8080/MagicEightBallService"
          binding = "basicHttpBinding"
          contract = "MagicEightBallServiceLib.IEightBall"/>
      </service>
    </services>
  </system.serviceModel>
</configuration>
```

Notice that the <system.serviceModel> element is the root for all of a host's WCF settings. Each service exposed by the host is represented by a <service> element that is wrapped by the <services> base element. Here, your single <service> element uses the (optional) name attribute to specify the friendly name of the service type.

The nested <endpoint> element handles the task of defining the address, the binding model (basicHttpBinding, in this example), and the fully qualified name of the interface type defining the WCF service contract (IEightBall). Because you are using an HTTP-based binding, you use the http:// scheme, specifying an arbitrary port ID.

Coding Against the ServiceHost Type

With the current configuration file in place, the actual programming logic required to complete the host is simple. When your executable starts up, you will create an instance of the `ServiceHost` class and inform it which WCF service it is responsible for hosting. At runtime, this object will automatically read the data within the scope of the `<system.serviceModel>` element of the host's `*.config` file to determine the correct address, binding, and contract. It will then create the necessary plumbing.

```
static void Main(string[] args)
{
    Console.WriteLine("***** Console Based WCF Host *****");
    using (ServiceHost serviceHost = new ServiceHost(typeof(MagicEightBallService)))
    {
        // Open the host and start listening for incoming messages.
        serviceHost.Open();

        // Keep the service running until the Enter key is pressed.
        Console.WriteLine("The service is ready.");
        Console.WriteLine("Press the Enter key to terminate service.");
        Console.ReadLine();
    }
}
```

If you run this application now, you will find that the host is alive in memory, ready to take incoming requests from remote clients.

■ **Note** Recall that you must launch Visual Studio with administrative privileges to run many WCF project types!

Specifying Base Addresses

Currently, you create your `ServiceHost` using a constructor that requires only the service's type information. However, it is also possible to pass in an array of `System.Uri` types as a constructor argument to represent the collection of addresses this service is accessible from. Currently, you find the address using the `*.config` file. However, assume that you were to update the using scope like this:

```
using (ServiceHost serviceHost = new
    ServiceHost(typeof(MagicEightBallService),
        new Uri[]{new Uri("http://localhost:8080/MagicEightBallService")}))
{
    ...
}
```

If you did, you could now define your endpoint like this:

```
<endpoint address = ""
    binding = "basicHttpBinding"
    contract = "MagicEightBallServiceLib.IEightBall"/>
```

Of course, too much hard-coding within a host's code base decreases flexibility. Therefore, the current host example assumes you create the service host simply by supplying the following type information, as you did before:

```
using (ServiceHost serviceHost = new ServiceHost(typeof(MagicEightBallService)))
{
    ...
}
```

One of the (slightly frustrating) aspects of authoring host *.config files is that you have several ways to construct the XML descriptors, based on the amount of hard-coding you have in the code base (as you have just seen in the case of the optional Uri array). Here's a reworking that shows yet another way to author *.config files:

```
<?xml version = "1.0" encoding = "utf-8" ?>
<configuration>
  <system.serviceModel>
    <services>
      <service name = "MagicEightBallServiceLib.MagicEightBallService">

        <!-- Address obtained from <baseAddresses> -->
        <endpoint address = ""
                  binding = "basicHttpBinding"
                  contract = "MagicEightBallServiceLib.IEightBall"/>

        <!-- List all of the base addresses in a dedicated section -->
        <host>
          <baseAddresses>
            <add baseAddress = "http://localhost:8080/MagicEightBallService"/>
          </baseAddresses>
        </host>
      </service>
    </services>
  </system.serviceModel>
</configuration>
```

In this case, the address attribute of the <endpoint> element is still empty; regardless of the fact that you do not specify an array of Uri objects in code when creating the ServiceHost, the application runs as before because the value is pulled from the baseAddresses scope. The benefit of storing the base address in a <host>'s <baseAddresses> region is that other parts of a *.config file also need to know the address of the service's endpoint. Thus, rather than having to copy and paste address values within a single *.config file, you can isolate the single value, as shown in the preceding snippet.

■ **Note** In a later example, you'll be introduced to a graphical configuration tool that allows you to author configuration files in a less tedious manner.

In any case, you have a bit more work to do before you build a client application to communicate with your service. Specifically, you will dig a bit deeper into the role of the ServiceHost class type and <service.serviceModel> element, as well as the role of metadata exchange (MEX) services.

Details of the ServiceHost Type

You use the `ServiceHost` class type to configure and expose a WCF service from the hosting executable. However, be aware that you will use this type directly only when building a custom *.exe to host your services. If you use IIS to expose a service, the `ServiceHost` object is created automatically on your behalf.

As you have seen, this type requires a complete service description, which is obtained dynamically through the configuration settings of the host's *.config file. While this happens automatically when you create a `ServiceHost` object, it is possible to configure the state of your `ServiceHost` object manually using a number of members. In addition to `Open()` and `Close()` (which communicate with your service in a synchronous manner), Table 25-8 illustrates some further members of interest.

Table 25-8. *Select Members of the ServiceHost Type*

| Members | Meaning in Life |
|--------------------------|--|
| Authorization | This property gets the authorization level for the service being hosted. |
| AddDefaultEndpoints() | This method is used to configure a WCF Service host programmatically so it uses any number of prebuilt endpoints supplied by the framework. |
| AddServiceEndpoint() | This method allows you to register an endpoint to the host programmatically. |
| BaseAddresses | This property obtains the list of registered base addresses for the current service. |
| BeginOpen() BeginClose() | These methods allow you to open and close a <code>ServiceHost</code> object asynchronously, using the standard asynchronous .NET delegate syntax. |
| CloseTimeout | This property allows you to set and get the time allowed for the service to close down. |
| Credentials | This property obtains the security credentials used by the current service. |
| EndOpen() EndClose() | These methods are the asynchronous counterparts to <code>BeginOpen()</code> and <code>BeginClose()</code> . |
| OpenTimeout | This property allows you to set and get the time allowed for the service to start up. |
| State | This property gets a value that indicates the current state of the communication object, which is represented by the <code>CommunicationState</code> enum (e.g., <code>opened</code> , <code>closed</code> , and <code>created</code>). |

You can see some additional aspects of `ServiceHost` in action by updating your `Program` class as follows, with a new static method that prints out the ABCs of each endpoint used by the host:

```
static void DisplayHostInfo(ServiceHost host)
{
    Console.WriteLine();
    Console.WriteLine("***** Host Info *****");

    foreach (System.ServiceModel.Description.ServiceEndpoint se
        in host.Description.Endpoints)
```

```

{
    Console.WriteLine("Address: {0}", se.Address);
    Console.WriteLine("Binding: {0}", se.Binding.Name);
    Console.WriteLine("Contract: {0}", se.Contract.Name);
    Console.WriteLine();
}
Console.WriteLine("*****");
}

```

Now, assuming that you call this new method from within `Main()` after opening your host:

```

using (ServiceHost serviceHost = new ServiceHost(typeof(MagicEightBallService)))
{
    // Open the host and start listening for incoming messages.
    serviceHost.Open();
    DisplayHostInfo(serviceHost);
    ...
}

```

the following statistics will be shown as output:

```

***** Console Based WCF Host *****

***** Host Info *****
Address: http://localhost:8080/MagicEightBallService
Binding: BasicHttpBinding
Contract: IEightBall
*****
The service is ready.
Press the Enter key to terminate service.

```

■ **Note** When running a host (or client) in this chapter, be sure to truly “run” the program from within Visual Studio (Ctrl+F5) and not debug (F5) the program to ensure your host and client processes can run independently.

Details of the <system.serviceModel> Element

Like any XML element, <system.serviceModel> can define a set of subelements, each of which can be qualified using various attributes. While you should consult the .NET Framework 4.6 SDK documentation for full details regarding the set of possible attributes, here is a skeleton that lists some (but not all) useful subelements:

```

<system.serviceModel>
  <behaviors>
  </behaviors>
  <client>
  </client>
  <commonBehaviors>
  </commonBehaviors>
  <diagnostics>
  </diagnostics>

```

```

<comContracts>
</comContracts>
<services>
</services>
<bindings>
</bindings>
</system.serviceModel>

```

You'll see more exotic configuration files as you move through the chapter; however, you can see the crux of each subelement in Table 25-9.

Table 25-9. Select Subelements of `<service.serviceModel>`

| Subelement | Meaning in Life |
|-----------------|--|
| behaviors | WCF supports various endpoint and service behaviors. In a nutshell, a <i>behavior</i> allows you to qualify further the functionality of a host, service, or client. |
| bindings | This element allows you to fine-tune each of the WCF-supplied bindings (e.g., <code>basicHttpBinding</code> and <code>netMsmqBinding</code>), as well as to specify any custom bindings used by the host. |
| client | This element contains a list of endpoints a client uses to connect to a service. Obviously, this is not particularly useful in a host's <code>*.config</code> file. |
| comContracts | This element defines COM contracts enabled for WCF and COM interoperability. |
| commonBehaviors | This element can be set only within a <code>machine.config</code> file. You can use it to define all of the behaviors used by each WCF service on a given machine. |
| diagnostics | This element contains settings for the diagnostic features of WCF. The user can enable/disable tracing, performance counters, and the WMI provider; the user can also add custom message filters. |
| services | This element contains a collection of WCF services exposed by the host. |

Enabling Metadata Exchange

Recall that WCF client applications communicate with the WCF service through an intervening proxy type. While you could author the proxy code completely by hand, doing so would be tedious and error-prone. Ideally, you could use a tool to generate the necessary grunge code (including the client-side `*.config` file). Thankfully, the .NET Framework 4.6 SDK provides a command-line tool (`svcutil.exe`) for this purpose. Also, Visual Studio provides similar functionality through its Project ► Add Service Reference menu option.

For these tools to generate the necessary proxy code/`*.config` file, however, they must be able to discover the format of the WCF service interfaces and any defined data contracts (e.g., the method names and type of parameters).

Metadata exchange (MEX) is a WCF *service behavior* that you can use to fine-tune how the WCF runtime handles your service. Simply put, each `<behavior>` element can define a set of activities a given service can subscribe to. WCF provides numerous behaviors out of the box, and it is possible to build your own.

The MEX behavior (which is disabled by default) will intercept any metadata requests sent through HTTP GET. You must enable MEX if you want to allow `svcutil.exe` or Visual Studio to automate the creation of the required client-side proxy `*.config` file.

Enabling MEX is a matter of tweaking the host's *.config file with the proper settings (or authoring the corresponding C# code). First, you must add a new <endpoint> just for MEX. Second, you need to define a WCF behavior to allow HTTP GET access. Third, you need to associate this behavior by name to your service using the behaviorConfiguration attribute on the opening <service> element. Finally, you need to add a <host> element to define the base address of this service (MEX will look here to figure out the locations of the types to describe).

■ **Note** You can bypass this final step if you pass in a System.Uri object to represent the base address as a parameter to the ServiceHost constructor.

Consider the following updated host *.config file, which creates a custom <behavior> element (named EightBallServiceMEXBehavior) that is associated to your service through the behaviorConfiguration attribute within the <service> definition:

```
<?xml version = "1.0" encoding = "utf-8" ?>
<configuration>
  <system.serviceModel>
    <services>
      <service name = "MagicEightBallServiceLib.MagicEightBallService"
        behaviorConfiguration="EightBallServiceMEXBehavior">
        <endpoint address = ""
          binding = "basicHttpBinding"
          contract = "MagicEightBallServiceLib.IEightBall"/>

        <!-- Enable the MEX endpoint -->
        <endpoint address = "mex"
          binding = "mexHttpBinding"
          contract = "IMetadataExchange" />

        <!-- Need to add this so MEX knows the address of our service -->
        <host>
          <baseAddresses>
            <add baseAddress = "http://localhost:8080/MagicEightBallService"/>
          </baseAddresses>
        </host>
      </service>
    </services>

    <!-- A behavior definition for MEX -->
    <behaviors>
      <serviceBehaviors>
        <behavior name = "EightBallServiceMEXBehavior" >
          <serviceMetadata httpGetEnabled = "true" />
        </behavior>
      </serviceBehaviors>
    </behaviors>
  </system.serviceModel>
</configuration>
```

You can now rerun your service host application and view its metadata description using the web browser of your choice. To do so, enter the address as the URL while the host is still running, like so:

```
http://localhost:8080/MagicEightBallService
```

Once you are at the home page for your WCF service (see Figure 25-6), you are provided with basic details regarding how to interact with this service programmatically, as well as a way to view the WSDL contract by clicking the hyperlink at the top of the page. Recall that Web Service Description Language (WSDL) is a grammar that describes the structure of web services at a given endpoint.

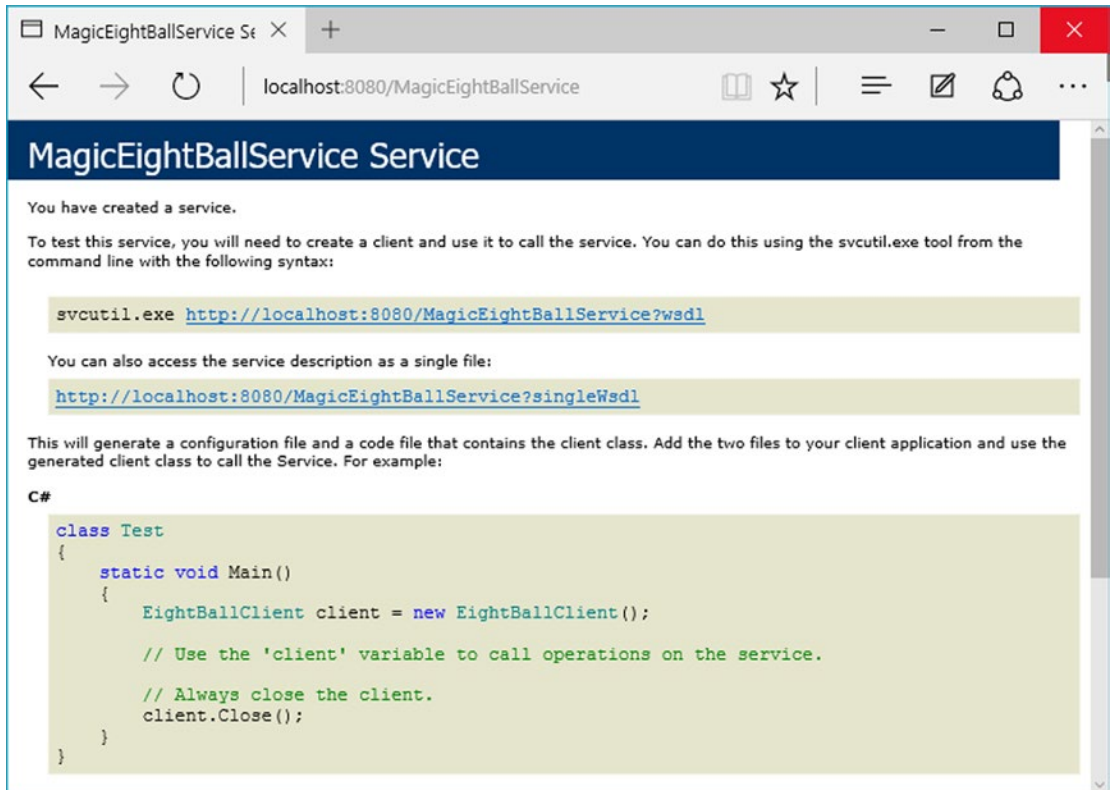

Figure 25-6. Ready-to-view metadata using MEX

Your host now exposes two different endpoints (one for the service and one for MEX), so your host's console output will appear like this:

```
***** Console Based WCF Host *****

***** Host Info *****
Address: http://localhost:8080/MagicEightBallService
Binding: BasicHttpBinding
Contract: IEightBall
```

```
Address: http://localhost:8080/MagicEightBallService/mex
Binding: MetadataExchangeHttpBinding
Contract: IMetadataExchange
*****
```

The service is ready.

■ **Source Code** You can find the `MagicEightBallServiceHost` project in the `MagicEightBallServiceHTTP` subdirectory of Chapter 25.

Building the WCF Client Application

Now that your host is in place, the final task is to build a piece of software to communicate with this WCF service type. While you could take the long road and build the necessary infrastructure by hand (a feasible but labor-intensive task), the .NET Framework 4.6 SDK provides several approaches to generate a client-side proxy quickly. Begin by creating a new Console Application project named `MagicEightBallServiceClient`.

Generating Proxy Code Using `svcutil.exe`

The first way you can build a client-side proxy is to use the `svcutil.exe` command-line tool. Using `svcutil.exe`, you can generate a new C# language file that represents the proxy code itself, as well as a client-side configuration file. You can do this by specifying the service's endpoint as the first parameter. You use the `/out:` flag to define the name of the *.cs file containing the proxy, and you use the `/config:` option to specify the name of the generated client-side *.config file.

Assuming your service is currently running, the following command set passed into `svcutil.exe` will generate two new files in the working directory (which should, of course, be entered as a single line within a developer command prompt):

```
svcutil http://localhost:8080/MagicEightBallService
/out:myProxy.cs /config:app.config
```

If you open the `myProxy.cs` file, you will find a client-side representation of the `IEightBall` interface, as well as a new class named `EightBallClient`, which is the proxy class itself. This class derives from the generic class, `System.ServiceModel.ClientBase<T>`, where `T` is the registered service interface.

In addition to a number of custom constructors, each method of the proxy (which is based on the original interface methods) will be implemented to use the inherited `Channel` property to invoke the correct service method. Here is a partial snapshot of the proxy type:

```
[System.Diagnostics.DebuggerStepThroughAttribute()]
[System.CodeDom.Compiler.GeneratedCodeAttribute("System.ServiceModel",
    "4.0.0.0")]
public partial class EightBallClient :
    System.ServiceModel.ClientBase<IEightBall>, IEightBall
{
    ...
}
```



```

public string ObtainAnswerToQuestion(string userQuestion)
{
    return base.Channel.ObtainAnswerToQuestion(userQuestion);
}
}

```

When you create an instance of the proxy type in your client application, the base class will establish a connection to the endpoint using the settings specified in the client-side application configuration file. Much like the server-side configuration file, the generated client-side `App.config` file contains an `<endpoint>` element and details about the `basicHttpBinding` used to communicate with the service.

You will also find the following `<client>` element, which (again) establishes the ABCs from the client's perspective:

```

<client>
  <endpoint
    address = "http://localhost:8080/MagicEightBallService"
    binding = "basicHttpBinding" bindingConfiguration = "BasicHttpBinding_IEightBall"
    contract = "IEightBall" name = "BasicHttpBinding_IEightBall" />
</client>

```

At this point, you could include these two files into a client project (and reference the `System.ServiceModel.dll` assembly) and then use the proxy type to communicate with the remote WCF service. However, you'll take a different approach here, looking at how Visual Studio can help you further automate the creation of client-side proxy files.

Generating Proxy Code Using Visual Studio

Like any good command-line tool, `svctutil.exe` provides a great number of options that you can use to control how the client proxy is generated. If you do not require these advanced options, you can generate the same two files using the Visual Studio IDE. For the client project, create a new Console Application project and simply select the Add Service Reference option from the Project menu.

After you activate this menu option, you will be prompted to enter the service URI. At this point, click the Go button to see the service description (see Figure 25-7).

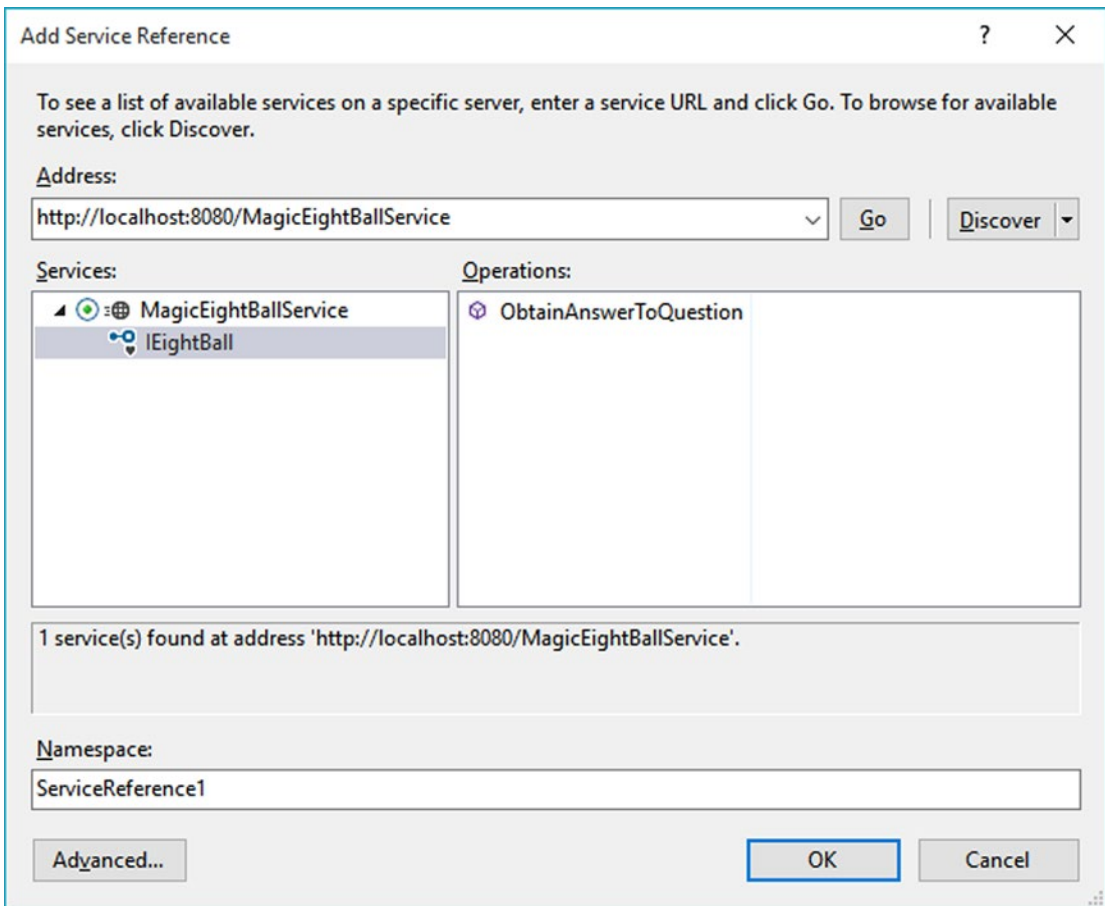

Figure 25-7. Generating the proxy files using Visual Studio

Beyond creating and inserting the proxy files into your current project, this tool is kind enough to reference the WCF assemblies automatically on your behalf. In accordance with a naming convention, the proxy class is defined within a namespace called `ServiceReference1`, which is nested in the client's namespace (to avoid possible name clashes). Here is the complete client code:

// Location of the proxy.

```
using MagicEightBallServiceClient.ServiceReference1;

namespace MagicEightBallServiceClient
{
    class Program
    {
        static void Main(string[] args)
        {
            Console.WriteLine("***** Ask the Magic 8 Ball *****\n");
        }
    }
}
```

```

using (EightBallClient ball = new EightBallClient())
{
    Console.Write("Your question: ");
    string question = Console.ReadLine();
    string answer =
        ball.ObtainAnswerToQuestion(question);
    Console.WriteLine("8-Ball says: {0}", answer);
}
Console.ReadLine();
}
}
}

```

Now assume your WCF console host is running so you can execute the client. Here is one possible output:

```

***** Ask the Magic 8 Ball *****

Your question: Will I ever finish Fallout 4?
8-Ball says: No

Press any key to continue...

```

■ **Source Code** You can find the `MagicEightBallServiceClient` project located in the `MagicEightBallServiceHTTP` subdirectory of Chapter 25.

Configuring a TCP-Based Binding

At this point, the host and client applications are both configured to use the simplest of the HTTP-based bindings, `basicHttpBinding`. Recall that the benefit of offloading settings to configuration files is that you can change the underlying plumbing in a declarative manner and expose multiple bindings for the same service.

To illustrate this, you can try a little experiment. Create a new folder on your C: drive (or wherever you happen to be saving your code) named `EightBallTCP`; in this new folder, create two subdirectories named `Host` and `Client`.

Next, use Windows Explorer to navigate to the `\bin\Debug` folder of the host project (from earlier in this chapter) and copy `MagicEightBallServiceHost.exe`, `MagicEightBallServiceHost.exe.config`, and `MagicEightBallServiceLib.dll` to the `C:\EightBallTCP\Host` folder. Now use a simple text editor to open the `*.config` file for editing and modify the existing contents as follows:

```

<?xml version = "1.0" encoding = "utf-8" ?>
<configuration>
  <system.serviceModel>
    <services>
      <service name = "MagicEightBallServiceLib.MagicEightBallService">
        <endpoint address = ""
          binding = "netTcpBinding"
          contract = "MagicEightBallServiceLib.IEightBall"/>

```

```

    <host>
      <baseAddresses>
        <add baseAddress = "net.tcp://localhost:8090/MagicEightBallService" />
      </baseAddresses>
    </host>
  </service>
</services>
</system.serviceModel>
</configuration>

```

Essentially, this host's *.config file strips out all the MEX settings (because you already built the proxy) and establishes that it is using the netTcpBinding binding type through a unique port. Now run the application by double-clicking the *.exe. If all is well, you should see the host output shown here:

```

***** Console Based WCF Host *****

***** Host Info *****
Address: net.tcp://localhost:8090/MagicEightBallService
Binding: NetTcpBinding
Contract: IEightBall

*****
The service is ready.
Press the Enter key to terminate service.

```

To complete the test, copy the MagicEightBallServiceClient.exe and MagicEightBallServiceClient.exe.config files from the \bin\Debug folder of the client application (from earlier in this chapter) into the C:\EightBallTCP\Client folder. Update the client configuration file like this:

```

<?xml version = "1.0" encoding = "utf-8" ?>
<configuration>
  <system.serviceModel>
    <client>
      <endpoint address = "net.tcp://localhost:8090/MagicEightBallService"
        binding = "netTcpBinding"
        contract = "ServiceReference1.IEightBall"
        name = "netTcpBinding_IEightBall" />
    </client>
  </system.serviceModel>
</configuration>

```

This client-side configuration file is a massive simplification compared to what the Visual Studio proxy generator authored. Notice how you have completely removed the existing <bindings> element. Originally, the *.config file contained a <bindings> element with a <basicHttpBinding> subelement that supplied numerous details of the client's binding settings (e.g., timeouts).

The truth is you never needed that detail for this example because you automatically obtain the default values of the underlying BasicHttpBinding object. If you needed to, you could of course update the existing <bindings> element to define details of the <netTcpBinding> subelement; however, doing so is not required if you are happy with the default values of the NetTcpBinding object.

In any case, you should now be able to run your client application. Assuming the host is still running in the background, you will be able to move data between your assemblies using TCP.

■ **Source Code** You can find the `MagicEightBallTCP` config files in the Chapter 25 subdirectory.

Simplifying Configuration Settings

As you were working through the first example of the chapter, you might have noticed that the hosting configuration logic is quite verbose. For example, your host's `*.config` file (for the original basic HTTP binding) needed to define an `<endpoint>` element for the service, a second `<endpoint>` element for MEX, a `<baseAddresses>` element (technically optional) to reduce redundant URIs, and then a `<behaviors>` section to define the runtime nature of metadata exchange.

To be sure, learning how to author hosting `*.config` files can be a major hurdle when building WCF services. To make matters more frustrating, a good number of WCF services tend to require the same basic settings in a host configuration file. For example, if you were to make a new WCF service and a new host and you wanted to expose this service using `<basicHttpBinding>` with MEX support, the required `*.config` file would look almost identical to the one you previously authored.

Thankfully, since the release of .NET 4.0, the Windows Communication Foundation API ships with a number of simplifications, including default settings (and other shortcuts) that make the process of building host configuration files much easier.

Leveraging Default Endpoints

Before support for default endpoints, if you called `Open()` on the `ServiceHost` object and you had not yet specified at least one `<endpoint>` element in your configuration file, the runtime would throw an exception. And you would get a similar result if you called `AddServiceEndpoint()` in code to specify an endpoint. However, since the release of .NET 4.5, every WCF service is automatically provided with *default endpoints* that capture commonplace configuration details for each supported protocol.

If you were to open the `machine.config` file for .NET 4.5, you would find a new element named `<protocolMapping>`. This element documents which WCF bindings to use by default, if you do not specify any.

```
<system.serviceModel>
...
  <protocolMapping>
    <add scheme = "http" binding="basicHttpBinding"/>
    <add scheme = "net.tcp" binding="netTcpBinding"/>
    <add scheme = "net.pipe" binding="netNamedPipeBinding"/>
    <add scheme = "net.msmsg" binding="netMsmqBinding"/>
  </protocolMapping>
  ...
</system.serviceModel>
```

To use these default bindings, all you need to do is specify base addresses in your host configuration file. To see this in action, open the HTTP-based `MagicEightBallServiceHost` project in Visual Studio. Now update your hosting `*.config` file by completely removing the `<endpoint>` element for your WCF service and all MEX-specific data. Your configuration file should now look like this:

```
<configuration>
  <system.serviceModel>
    <services>
      <service name = "MagicEightBallServiceLib.MagicEightBallService" >
        <host>
          <baseAddresses>
            <add baseAddress = "http://localhost:8080/MagicEightBallService"/>
          </baseAddresses>
        </host>
      </service>
    </services>
  </system.serviceModel>
</configuration>
```

Because you specified a valid HTTP `<baseAddress>`, your host will automatically use `basicHttpBinding`. If you run your host again, you will see the same listing of ABC data.

```
***** Console Based WCF Host *****

***** Host Info *****
Address: http://localhost:8080/MagicEightBallService
Binding: BasicHttpBinding
Contract: IEightBall

*****
The service is ready.
Press the Enter key to terminate service.
```

You have not yet enabled MEX, but you will do so in a moment using another simplification known as *default behavior configurations*. First, however, you will learn how to expose a single WCF service using multiple bindings.

Exposing a Single WCF Service Using Multiple Bindings

Since its first release, WCF has had the ability to allow a single host to expose a WCF service using multiple endpoints. For example, you could expose the `MagicEightBallService` using HTTP, TCP, and named pipe bindings simply by adding new endpoints to your configuration file. Once you restart the host, all the necessary plumbing is created automatically.

This is a huge benefit for many reasons. Before WCF, it was difficult to expose a single service using multiple bindings because each type of binding (e.g., HTTP and TCP) had its own programming model.

Nevertheless, the ability to allow a caller to pick the most appropriate binding is extremely useful. In-house callers might like to use TCP bindings that an outwardly facing client (outside of your company firewall) would need to use HTTP to access, while clients on the same machine might opt to use a named pipe.

To do this before .NET 4.5, your hosting configuration file would need to define multiple <endpoint> elements manually. It would also have to define multiple <baseAddress> elements for each protocol. However, today you can simply author the following configuration file:

```
<configuration>
  <system.serviceModel>
    <services>
      <service name = "MagicEightBallServiceLib.MagicEightBallService" >
        <host>
          <baseAddresses>
            <add baseAddress = "http://localhost:8080/MagicEightBallService"/>
            <add baseAddress =
              "net.tcp://localhost:8099/MagicEightBallService"/>
          </baseAddresses>
        </host>
      </service>
    </services>
  </system.serviceModel>
</configuration>
```

If you compile your project (to refresh the deployed *.config file) and restart the host, you will now see the following endpoint data:

```
***** Console Based WCF Host *****

***** Host Info *****
Address: http://localhost:8080/MagicEightBallService
Binding: BasicHttpBinding
Contract: IEightBall

Address: net.tcp://localhost:8099/MagicEightBallService
Binding: NetTcpBinding
Contract: IEightBall

*****
The service is ready.
Press the Enter key to terminate service.
```

Now that your WCF service can be reachable from two unique endpoints, you might wonder how the caller is able to select between them. When you generate a client-side proxy, the Add Service reference tool will give each exposed endpoint a string name in the client-side *.config file. In code, you can pass in the correct string name to the proxy's constructor, and sure enough, the correct binding will be used. Before you can do this, however, you need to reestablish MEX for this modified hosting configuration file and learn how to tweak the settings of a default binding.

Changing Settings for a WCF Binding

If you specify the ABCs of a service in C# code (which you will do later in this chapter), it becomes obvious how you change the default settings of a WCF binding; you simply change the property values of the object! For example, if you want to use `BasicHttpBinding` but also want to change the timeout settings, you could do so as follows:

```
void ConfigureBindingInCode()
{
    BasicHttpBinding binding = new BasicHttpBinding();
    binding.OpenTimeout = TimeSpan.FromSeconds(30);
    ...
}
```

It has always been possible to configure settings for a binding in a declarative manner. For example, .NET 3.5 lets you build a host configuration file that changed the `OpenTimeout` property of `BasicHttpBinding`, like so:

```
<configuration>
  <system.serviceModel>

    <bindings>
      <basicHttpBinding>
        <binding name = "myCustomHttpBinding"
          openTimeout = "00:00:30" />
      </basicHttpBinding>
    </bindings>

    <services>
      <service name = "WcfMathService.MyCalc">
        <endpoint address = "http://localhost:8080/MyCalc"
          binding = "basicHttpBinding"
          bindingConfiguration = "myCustomHttpBinding"
          contract = "WcfMathService.IBasicMath" />
      </service>
    </services>
  </system.serviceModel>
</configuration>
```

Here, you have a configuration file for a service named `WcfMathService.MyCalc`, which supports a single interface named `IBasicMath`. Note how the `<bindings>` section allows you to define a named `<binding>` element, which tweaks settings for a given binding. Within the `<endpoint>` of the service, you can connect your specific settings using the `bindingConfiguration` attribute.

This sort of hosting configuration still works as expected; however, if you leverage a default endpoint, you can't connect the `<binding>` to the `<endpoint>`! As luck would have it, you can control the settings of a default endpoint simply by omitting the `name` attribute of the `<binding>` element. For example, this snippet changes some properties of the default `BasicHttpBinding` and `NetTcpBinding` objects used in the background:

```
<configuration>
  <system.serviceModel>
    <services>
```



```

<service name = "MagicEightBallServiceLib.MagicEightBallService" >
  <host>
    <baseAddresses>
      <add baseAddress = "http://localhost:8080/MagicEightBallService"/>
      <add baseAddress =
        "net.tcp://localhost:8099/MagicEightBallService"/>
    </baseAddresses>
  </host>
</service>
</services>

<bindings>
  <basicHttpBinding>
    <binding openTimeout = "00:00:30" />
  </basicHttpBinding>
  <netTcpBinding>
    <binding closeTimeout = "00:00:15" />
  </netTcpBinding>
</bindings>

</system.serviceModel>
</configuration>

```

Leveraging the Default MEX Behavior Configuration

A proxy generation tool must discover the composition of a service at runtime before it can do its work. In WCF, you allow this runtime discovery to occur by enabling MEX. Again, most host configuration files need to enable MEX (at least during development); fortunately, the way you configure MEX seldom changes, so .NET 4.5 and above provides a few handy shortcuts.

The most useful shortcut is out-of-the-box MEX support. You don't need to add a MEX endpoint, define a named MEX service behavior, and then connect the named binding to the service (as you did in the HTTP version of the MagicEightBallServiceHost); instead, you can now simply add the following:

```

<configuration>
  <system.serviceModel>
    <services>
      <service name = "MagicEightBallServiceLib.MagicEightBallService" >
        <host>
          <baseAddresses>
            <add baseAddress = "http://localhost:8080/MagicEightBallService"/>
            <add baseAddress =
              "net.tcp://localhost:8099/MagicEightBallService"/>
          </baseAddresses>
        </host>
      </service>
    </services>

    <bindings>
      <basicHttpBinding>
        <binding openTimeout = "00:00:30" />
      </basicHttpBinding>

```

```

    <netTcpBinding>
      <binding closeTimeout = "00:00:15" />
    </netTcpBinding>
  </bindings>

  <behaviors>
    <serviceBehaviors>
      <behavior>
        <!-- To get default MEX,
              don't name your <serviceMetadata> element -->
        <serviceMetadata httpGetEnabled = "true"/>
      </behavior>
    </serviceBehaviors>
  </behaviors>
</system.serviceModel>
</configuration>

```

The trick is that the `<serviceMetadata>` element no longer has a `name` attribute (also notice the `<service>` element no longer needs the `behaviorConfiguration` attribute). With this adjustment, you get free MEX support at runtime. To test this, you can run your host (after you compile to refresh the configuration file) and type in the following URL in a browser:

```
http://localhost:8080/MagicEightBallService
```

After you do this, you can click the `wsdl` link at the top of the web page to see the WSDL description of the service (refer to Figure 25-6 for a refresher). Note that you do not see the host's console window print data for the MEX endpoint because you have not explicitly defined an endpoint for `IMetadataExchange` in your configuration file. Nevertheless, MEX is enabled, and you can start to build client proxies.

Refreshing the Client Proxy and Selecting the Binding

Assuming your updated host has been compiled and is running in the background, you will now want to open the client application and refresh the current service reference. Begin by opening the `Service References` folder in the Solution Explorer. Next, right-click the current `ServiceReference1` and pick the `Update Service Reference` menu option (see Figure 25-8).

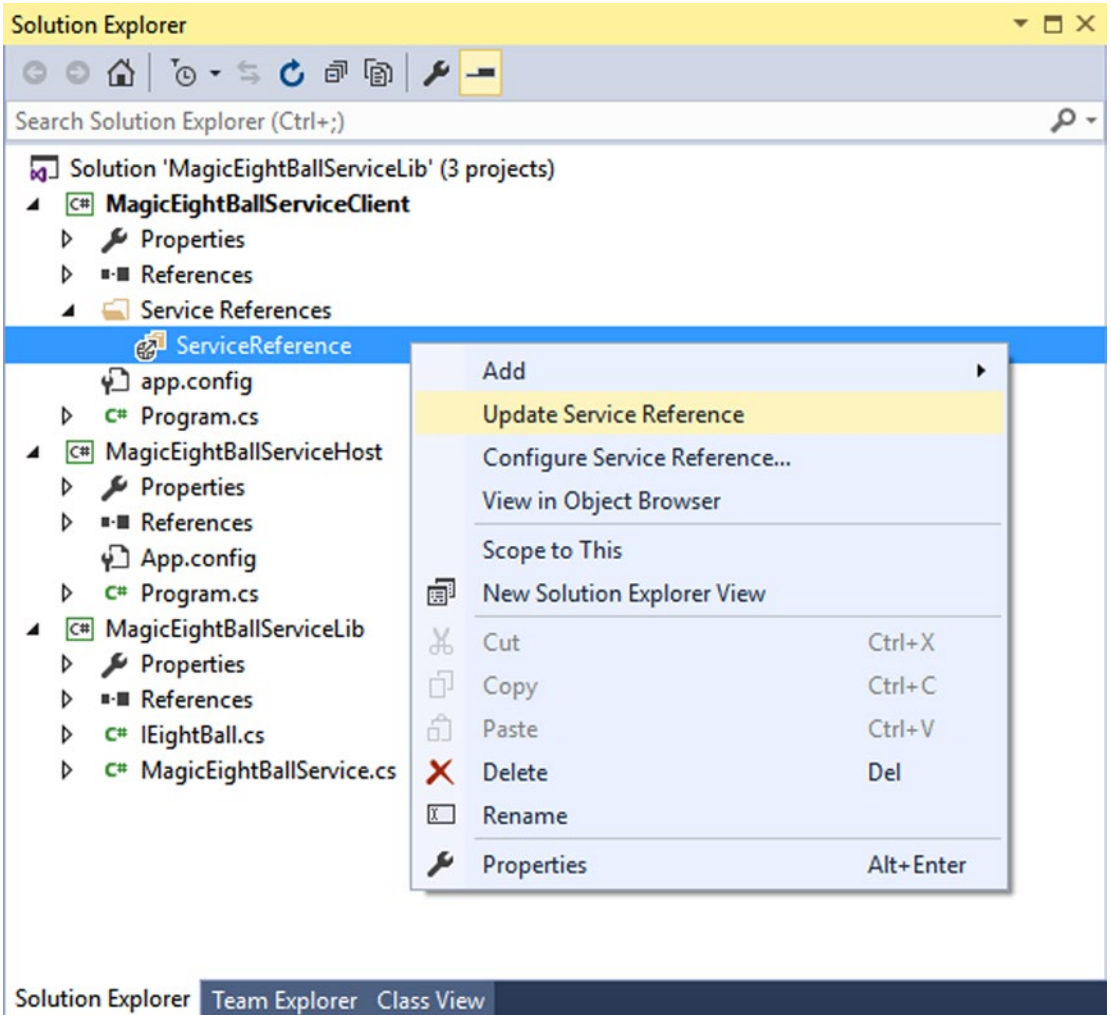

Figure 25-8. Refreshing the proxy and client-side *.config file

After you have done this, you will see that the client-side *.config file has two bindings to select from: one for HTTP and one for TCP. As you can see, you give each binding a fitting name. Here is a partial listing of the refreshed configuration file:

```
<configuration>
  <system.serviceModel>

    <bindings>
      <basicHttpBinding>
        <binding name = "BasicHttpBinding_IEightBall" ... />
      </basicHttpBinding>
```

```

    <netTcpBinding>
      <binding name = "NetTcpBinding_IEightBall" ... />
    </netTcpBinding>
  </bindings>
...
</system.serviceModel>
</configuration>

```

The client can use these names when it creates the proxy object to select the binding it wants to use. Thus, if your client would like to use TCP, you could update the client side C# code as follows:

```

static void Main(string[] args)
{
    Console.WriteLine("***** Ask the Magic 8 Ball *****\n");

    using (EightBallClient ball = new EightBallClient("NetTcpBinding_IEightBall"))
    {
        ...
    }
    Console.ReadLine();
}

```

If a client would rather use the HTTP binding, you could write the following:

```

using (EightBallClient ball = new
    EightBallClient("BasicHttpBinding_IEightBall"))
{
    ...
}

```

That wraps up the current example, which showcased a number of useful shortcuts. These features simplify how you can author hosting configuration files. Next up, you will see how to use the WCF Service Library project template.

■ **Source Code** You can find the `MagicEightBallServiceHTTPDefaultBindings` project located in the [Chapter 25](#) subdirectory.

Using the WCF Service Library Project Template

Before building a more exotic WCF service that communicates with the `AutoLot` database you created in [Chapter 21](#), the next example will illustrate a number of important topics, including the benefits of the WCF Service Library project template, the WCF Test Client, the WCF configuration editor, hosting WCF services within a Windows service, and asynchronous client calls. To stay focused on these new concepts, this WCF service will be kept intentionally simple.

Building a Simple Math Service

To begin, create a new WCF Service Library project named `MathServiceLibrary`, making sure you select the correct option under the WCF node of the New Project dialog box (see Figure 25-2 if you need a nudge). Now change the name of the initial `IService1.cs` file to `IBasicMath.cs`. After you do so, *delete* all the example code within the `MathServiceLibrary` namespace and replace it with the following code:

```
[ServiceContract(Namespace="http://MyCompany.com")]
public interface IBasicMath
{
    [OperationContract]
    int Add(int x, int y);
}
```

Next, change the name of the `Service1.cs` file to `MathService.cs`, delete all the example code within the `MathServiceLibrary` namespace (again), and implement your service contract as follows:

```
public class MathService : IBasicMath
{
    public int Add(int x, int y)
    {
        // To simulate a lengthy request.
        System.Threading.Thread.Sleep(5000);
        return x + y;
    }
}
```

Also take a moment to notice that this `*.config` file has already been enabled to support MEX; by default, your service endpoint uses the `basicHttpBinding` protocol.

Testing the WCF Service with `WcfTestClient.exe`

One benefit of using the WCF Service Library project is that when you debug or run your library, it will read the settings in the `*.config` file and use them to load the WCF Test Client application (`WcfTestClient.exe`). This GUI-based application allows you to test each member of your service interface as you build the WCF service; this means you don't have to build a host/client manually simply for testing purposes, as you did previously.

Figure 25-9 shows the testing environment for `MathService`. Notice that when you double-click an interface method, you can specify input parameters and invoke the member.

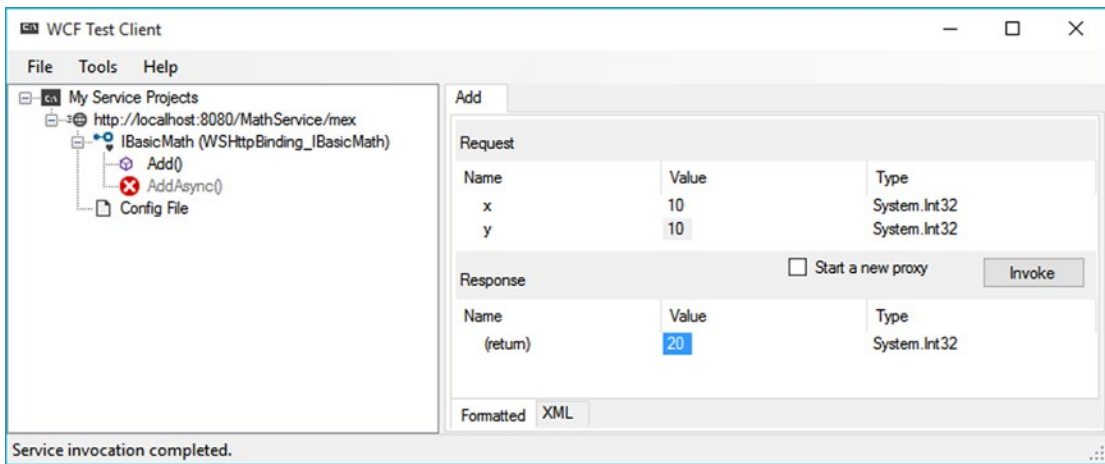

Figure 25-9. Testing the WCF service using *WcfTestClient.exe*

This utility works out of the box when you have created a WCF Service Library project; however, be aware that you can use this tool to test any WCF service when you start it at the command line by specifying a MEX endpoint. For example, if you were to start the *MagicEightBallServiceHost.exe* application, you could specify the following command at a developer command prompt:

```
wcftestclient http://localhost:8080/MagicEightBallService
```

After you do this, you can invoke *ObtainAnswerToQuestion()* in a similar manner.

Altering Configuration Files Using *SvcConfigEditor.exe*

Another benefit of using the WCF Service Library project is that you are able to right-click the *App.config* file within the Solution Explorer to activate the GUI-based Service Configuration Editor, *SvcConfigEditor.exe* (see Figure 25-10). This same technique can be used from a client application that has referenced a WCF service.

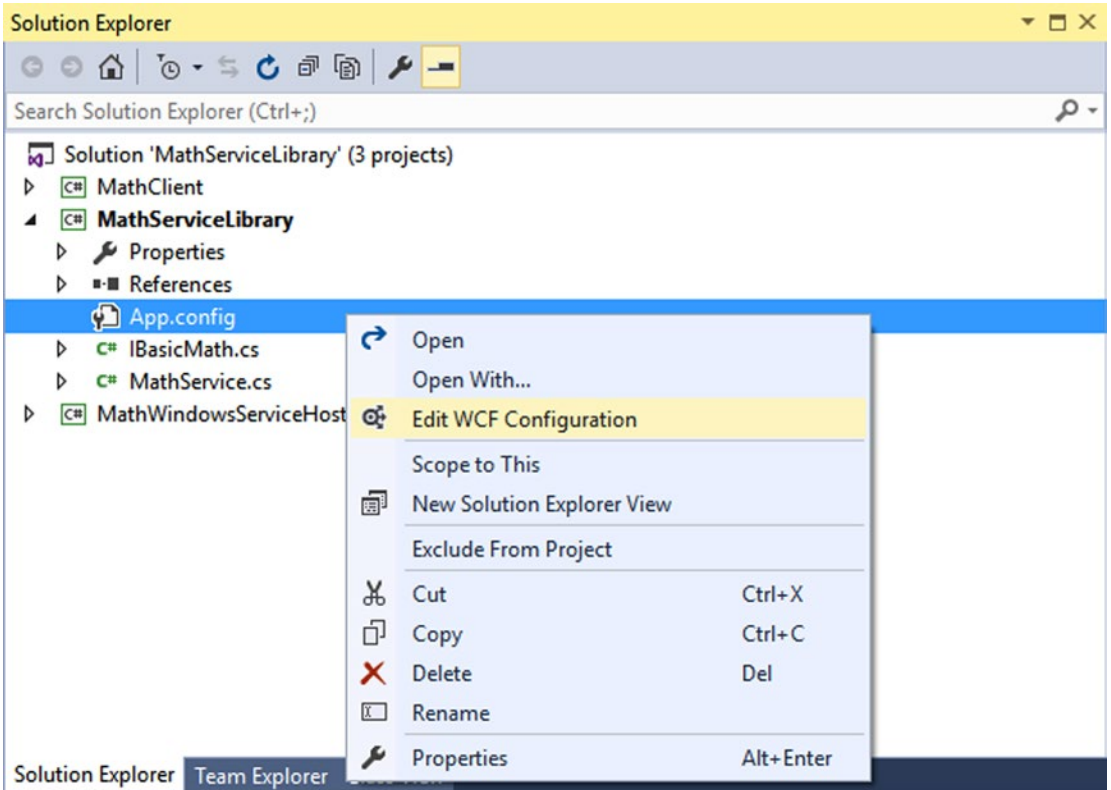

Figure 25-10. GUI-based *.config file editing starts here

After you activate this tool, you can change the XML-based data using a friendly user interface. Using a tool such as this to maintain your *.config files provides many benefits. First (and foremost), you can rest assured that the generated markup conforms to the expected format and is typo-free. Second, it is a great way to see the valid values that could be assigned to a given attribute. Finally, you no longer need to author tedious XML data manually.

Figure 25-11 shows the overall look and feel of the Service Configuration Editor. Truth be told, an entire chapter could be devoted to describing all the interesting options `SvcConfigEditor.exe` supports. Be sure to take time to investigate this tool; also be aware that you can access a fairly detailed help system by pressing F1.

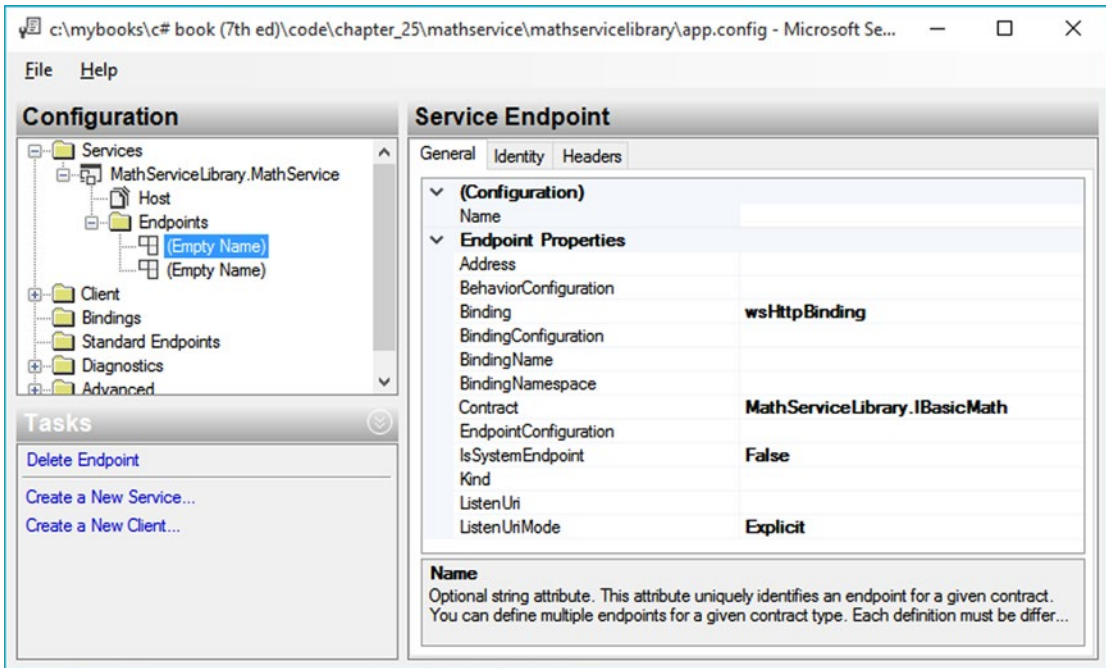

Figure 25-11. Working with the WCF Service Configuration Editor

Note The SvcConfigEditor.exe utility can edit (or create) configuration files, even if you do not select an initial WCF Service Library project. Use a Developer Command window to launch the tool and then use the File Open menu option to load an existing *.config file for editing.

You have no need to further configure your WCF MathService; at this point, you can move on to the task of building a custom host.

Hosting the WCF Service Within a Windows Service

Hosting a WCF service from within a console application (or within a GUI desktop application, for that matter) is not an ideal choice for a production-level server, given that the host must remain running visibly in the background to service clients. Even if you were to minimize the hosting application to the Windows taskbar, it would still be far too easy to accidentally shut down the host, thereby terminating the connection with any client applications.

Note While it is true that a desktop Windows application does not *have* to show a main window, a typical *.exe does require user interaction to load the executable. However, you can configure a Windows service (described next) to run even if no users are currently logged on to the workstation.

If you build an in-house WCF application, another alternative you have is to host your WCF Service Library from within a dedicated Windows service. One benefit of doing so is that you can configure a Windows service to start automatically when the target machine boots up. Another benefit is that Windows services run invisibly in the background (unlike your console application) and do not require user interactivity (and you don't need IIS installed on the host computer).

Next, you will learn how to build such a host. Begin by creating a new Windows service project named `MathWindowsServiceHost` (see Figure 25-12). After you do this, rename your initial `Service1.cs` file to `MathWinService.cs` using the Solution Explorer.

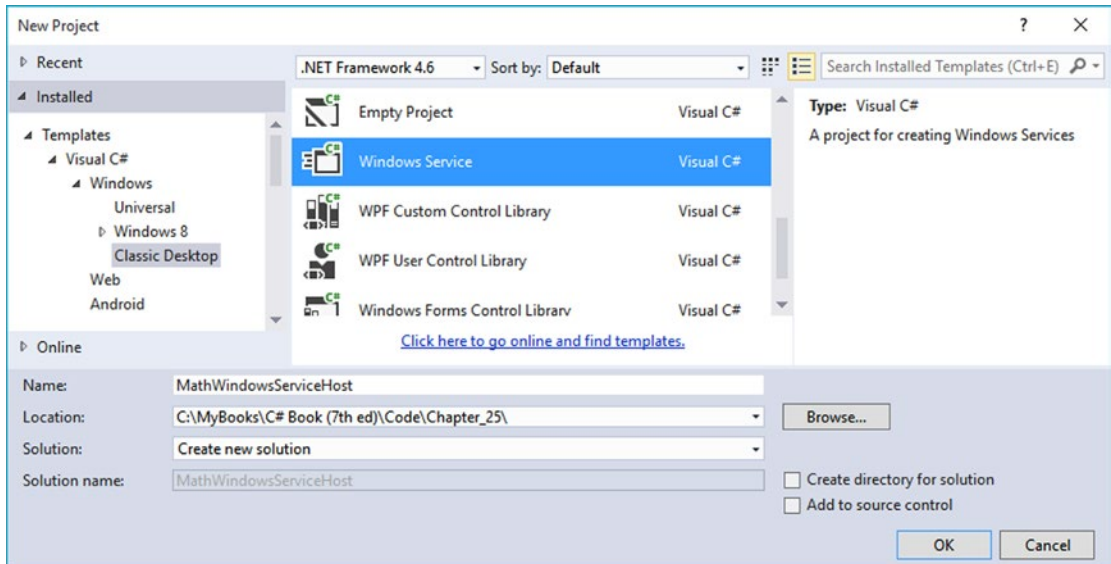

Figure 25-12. Creating a Windows service to host your WCF service

Specifying the ABCs in Code

Now assume you have set a reference to your `MathServiceLibrary.dll` and `System.ServiceModel.dll` assemblies. All you need to do is use the `ServiceHost` type in the `OnStart()` and `OnStop()` methods of your Windows service type. Open the code file for your service host class (by right-clicking the designer and selecting View Code) and add the following logic:

```
// Be sure to import these namespaces:
using MathServiceLibrary;
using System.ServiceModel;

namespace MathWindowsServiceHost
{
    public partial class MathWinService: ServiceBase
    {
        // A member variable of type ServiceHost.
        private ServiceHost myHost;
```

```

public MathWinService()
{
    InitializeComponent();
}

protected override void OnStart(string[] args)
{
    // Just to be really safe.
    if (myHost != null)
    {
        myHost.Close();
        myHost = null;
    }

    // Create the host.
    myHost = new ServiceHost(typeof(MathService));

    // The ABCs in code!
    Uri address = new Uri("http://localhost:8080/MathServiceLibrary");
    WSHttpBinding binding = new WSHttpBinding();
    Type contract = typeof(IBasicMath);

    // Add this endpoint.
    myHost.AddServiceEndpoint(contract, binding, address);

    // Open the host.
    myHost.Open();
}

protected override void OnStop()
{
    // Shut down the host.
    if(myHost != null)
        myHost.Close();
}
}
}

```

While nothing prevents you from using a configuration file when building a Windows service host for a WCF service, here (for a change of pace) you establish the endpoint programmatically using the `Uri`, `WSHttpBinding`, and `Type` classes, rather than by using a `*.config` file. After you create each aspect of the ABCs, you inform the host programmatically by calling `AddServiceEndpoint()`.

If you want to inform the runtime that you want to gain access to each of the default endpoint bindings stored in the `.NET 4.6 machine.config` file, you can simplify your programming logic by specifying base addresses when you invoke the constructor of `ServiceHost`. In this case, you do not need to specify the ABCs manually in code or call `AddServiceEndpoint()`; instead, you call `AddDefaultEndpoints()`. Consider the following update:

```

protected override void OnStart(string[] args)
{
    if (myHost != null)

```

```

{
    myHost.Close();
}
// Create the host and specify a URL for an HTTP binding.
myHost = new ServiceHost(typeof(MathService),
    new Uri("http://localhost:8080/MathServiceLibrary"));

// Opt in for the default endpoints!
myHost.AddDefaultEndpoints();

// Open the host.
myHost.Open();
}

```

Enabling MEX

While you could enable MEX programmatically as well, here you will opt for a configuration file. Modify the `App.config` file into your Windows service project that contains the following default MEX settings:

```

<?xml version = "1.0" encoding = "utf-8" ?>
<configuration>
  <system.serviceModel>
    <services>
      <service name = "MathServiceLibrary.MathService">
        </service>
      </services>

    <behaviors>
      <serviceBehaviors>
        <behavior>
          <serviceMetadata httpGetEnabled = "true"/>
        </behavior>
      </serviceBehaviors>
    </behaviors>

  </system.serviceModel>
</configuration>

```

Creating a Windows Service Installer

To register your Windows service with the operating system, you need to add an installer to your project that contains the necessary code to allow you to register the service. To do so, right-click the Windows service designer surface and select Add Installer (see Figure 25-13).

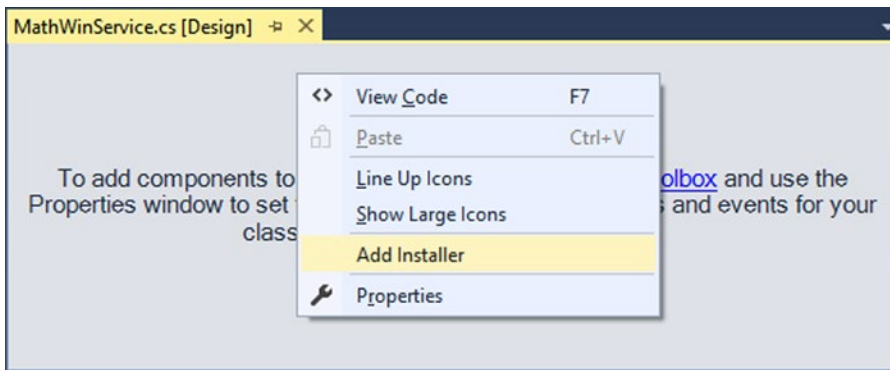

Figure 25-13. Adding an installer for the Windows service

Once you do this, you can see two components have been added to a new designer surface representing the installer. The first component (named `serviceProcessInstaller1` by default) represents an item that can install a new Windows service on the target machine. Select this item on the designer and use the Properties window to set the `Account` property to `LocalSystem` (see Figure 25-14).

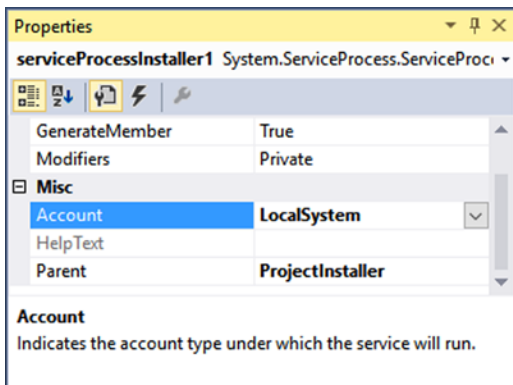

Figure 25-14. Be sure to run the Windows service as a local system account

The second component (named `serviceInstaller1`) represents a type that will install your particular Windows service. Again, use the Properties window to change the `ServiceName` property to `MathService`, set the `StartType` property to `Automatic`, and add a friendly description of your Windows service using the `Description` property (see Figure 25-15).

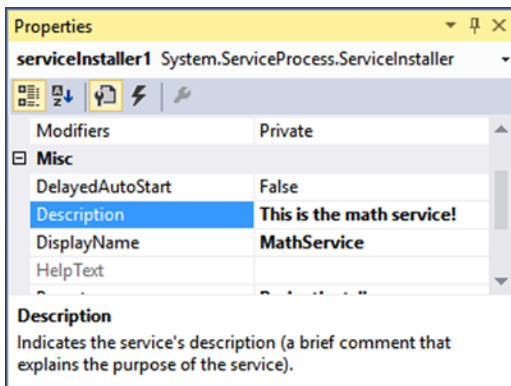

Figure 25-15. Configuring installer details

At this point, you can compile your application.

Installing the Windows Service

A Windows service can be installed on the host machine using a traditional setup program (such as an *.msi installer) or via the `installutil.exe` command-line tool.

■ **Note** To install a Windows service using `installutil.exe`, you must start the developer command prompt under administrative privileges. To do so, right-click the Developer Command Prompt icon and select **Run As Administrator**.

Using a command prompt, change into the `\bin\Debug` folder of your `MathWindowsServiceHost` project. Now, enter the following command (be sure you are running as administrator!):

```
installutil MathWindowsServiceHost.exe
```

Assuming the installation succeeded, you can now open the Services applet located under the Administrative Tools folder of your Control Panel. You should see the friendly name of your Windows service listed alphabetically. After you locate it, make sure you start the service on your local machine using the Start link (see Figure 25-16).

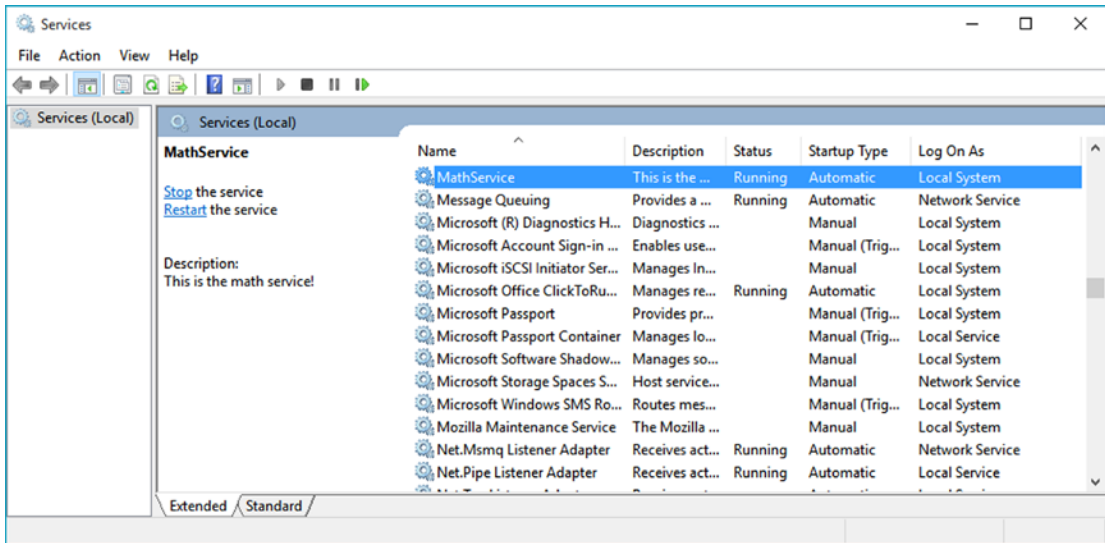

Figure 25-16. Viewing your Windows service, which hosts your WCF service

Now that the service is alive and kicking, the last step is to build a client application to consume its services.

■ **Source Code** You can find the `MathWindowsServiceHost` project located in the [Chapter 25](#) subdirectory.

Invoking a Service Asynchronously from the Client

Create a new Console Application project named `MathClient` and set a service reference to your running WCF service (that is currently hosted by the Windows service running in the background) using the Add Service Reference option of Visual Studio (you'll need to type the URL in the Addresses box, which should be `http://localhost:8080/MathServiceLibrary`). Don't click the OK button yet, however! Notice that the Add Service Reference dialog box has an Advanced button in the lower-left corner (see [Figure 25-17](#)).

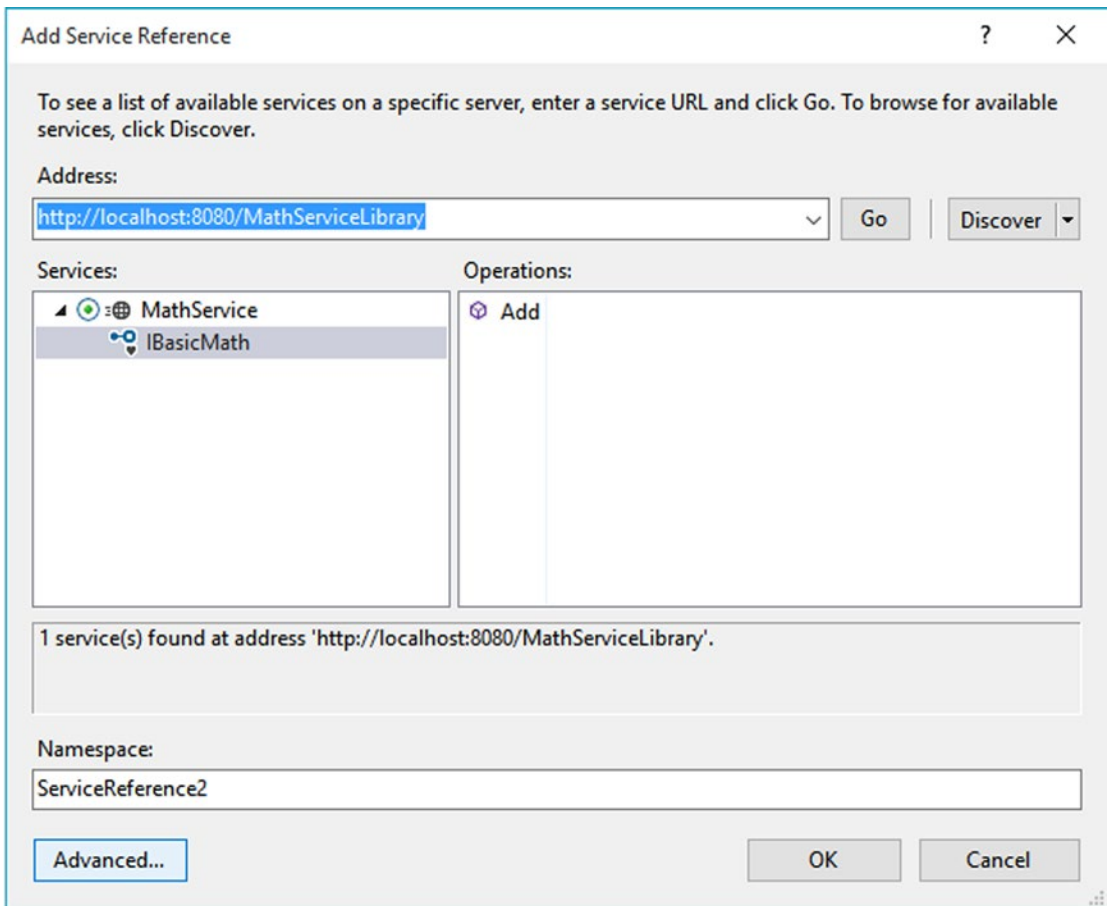

Figure 25-17. Referencing your *MathService* and getting ready to configure advanced settings

Click this button now to view the additional proxy configuration settings (see Figure 25-18). You can use this dialog box to generate code that allows you to call the remote methods in an asynchronous manner, provided you check the “Generate asynchronous operators” radio option. Go ahead and check this option for the time being.

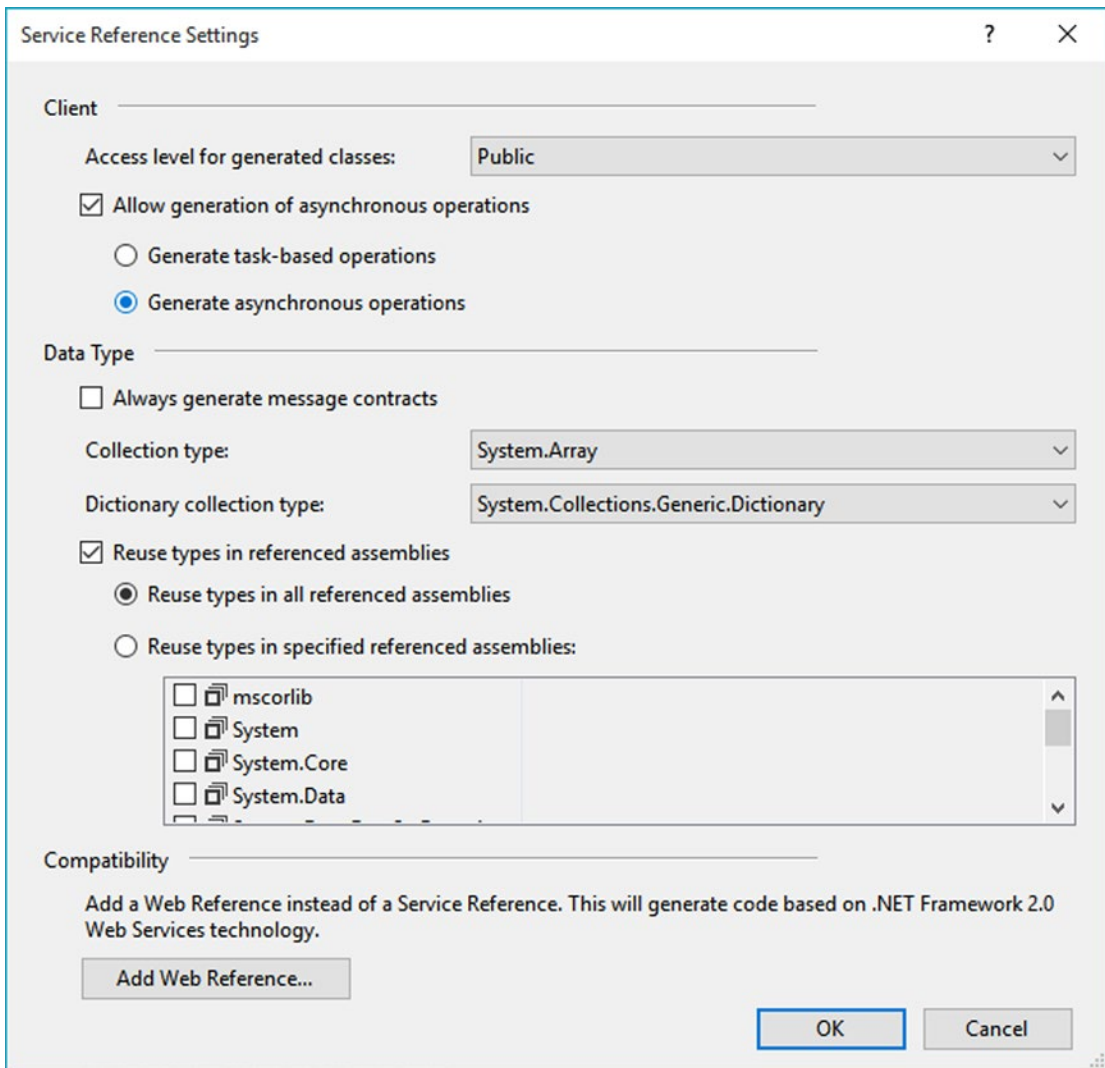

Figure 25-18. Advanced client-side proxy configuration options

At this point, the proxy code contains additional methods that allow you to invoke each member of the service contract using the expected Begin/End asynchronous invocation pattern described in Chapter 19. Here is a simple implementation that uses a lambda expression rather than a strongly typed AsyncCallback delegate:

```
using System;
using MathClient.ServiceReference1;
...

namespace MathClient
{
    class Program
    {
```



```

static void Main(string[] args)
{
    Console.WriteLine("***** The Async Math Client *****\n");

    using (BasicMathClient proxy = new BasicMathClient())
    {
        proxy.Open();

        // Add numbers in an async manner, using a lambda expression.
        IAsyncResult result = proxy.BeginAdd(2, 3,
            ar =>
            {
                Console.WriteLine("2 + 3 = {0}", proxy.EndAdd(ar));
            },
            null);

        while (!result.IsCompleted)
        {
            Thread.Sleep(200);
            Console.WriteLine("Client working...");
        }
    }
    Console.ReadLine();
}
}
}

```

■ **Source Code** You can find the MathClient project located in the Chapter 25 subdirectory.

Designing WCF Data Contracts

This chapter's final example shows you how to construct WCF *data contracts*. The previous WCF services defined simple methods that operate on primitive CLR data types. When you use any of the HTTP binding types (e.g., `basicHttpBinding` and `wsHttpBinding`), incoming and outgoing simple data types are automatically formatted into XML elements. On a related note, if you use a TCP-based binding (such as `netTcpBinding`), the parameters and return values of simple data types are transmitted using a compact binary format.

■ **Note** The WCF runtime will also automatically encode any type marked with the `[Serializable]` attribute; however, this is not the preferred way to define WCF contracts, and it is included only for backward compatibility.

However, when you define service contracts that use custom classes as parameters or return values, it is a best practice to model such data using WCF data contracts. Simply put, a data contract is a type adorned with the `[DataContract]` attribute. Likewise, you must mark each field you expect to be used as part of the proposed contract with the `[DataMember]` attribute.

■ **Note** In earlier versions of the .NET platform, it was mandatory to use [DataContract] and [DataMember] to ensure custom data types were correctly represented. Microsoft has since relaxed this requirement; technically speaking, you are not required to use these attributes on custom data types; however, it is considered a .NET best practice.

Using the Web-centric WCF Service Project Template

The next WCF service will allow external callers to interact with the AutoLot database you created in Chapter 21. Moreover, this final WCF service will be created using the web-based WCF Service template and be hosted under IIS.

To begin, launch Visual Studio (with administrator rights) and access the File ► New ► Web Site menu option. Select the WCF Service project type and ensure the Web Location drop-down is set to HTTP (which will install the service under IIS). Expose the service from the following URI:

`http://localhost/AutoLotWCFService`

Figure 25-19 shows the configured project.

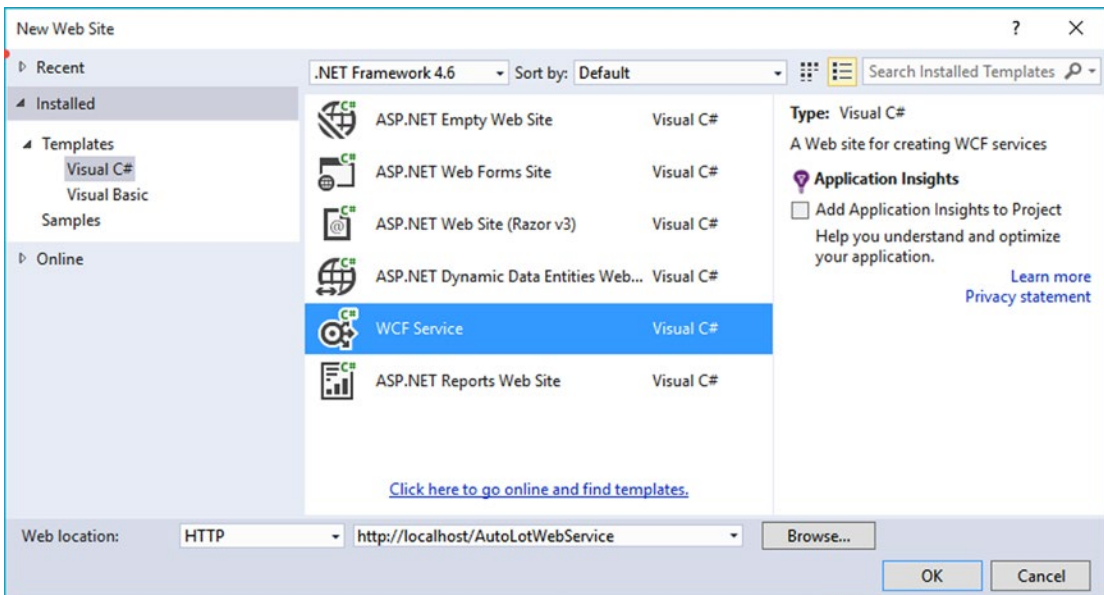

Figure 25-19. Creating a web-centric WCF service

After you have done this, set a reference to the `AutoLotDAL.dll` assembly you created in Chapter 21 (using the Website ► Add Reference menu option). You have been given some example starter code (located under the `App_Code` folder), which you will want to delete. Begin by renaming the initial `IService.cs` file to `IAutoLotService.cs` and then define the initial service contract within your newly named file, like so:

```
[ServiceContract]
public interface IAutoLotService
{
    [OperationContract]
    void InsertCar(int id, string make, string color, string petname);

    [OperationContract]
    void InsertCar(InventoryRecord car);

    [OperationContract]
    InventoryRecord[] GetInventory();
}
```

This interface defines three methods, one of which returns an array of the (yet-to-be-created) `InventoryRecord` type. You might recall that the `GetInventory()` method of `InventoryDAL` simply returned a `DataTable` object, and this might make you wonder why your service's `GetInventory()` method does not do the same.

While it would work to return a `DataTable` from a WCF service method, recall that WCF was built to honor the use of SOA principles, one of which is to program against contracts, not implementations.

Therefore, you won't return the .NET-specific `DataTable` type to an external caller; instead, you will return a custom data contract (`InventoryRecord`) that will be correctly expressed in the contained WSDL document in an agnostic manner.

Also note that the interface listed previously defines an overloaded method named `InsertCar()`. The first version takes four incoming parameters, while the second version takes an `InventoryRecord` type as input. You can define the `InventoryRecord` data contract as follows:

```
[DataContract]
public class InventoryRecord
{
    [DataMember]
    public int ID;

    [DataMember]
    public string Make;

    [DataMember]
    public string Color;

    [DataMember]
    public string PetName;
}
```

If you were to implement the `IAutoLotService` interface as it now stands, and then build a host and attempt to call these methods from a client, you might be surprised to see that you would get a runtime exception. The reason: one of the requirements of a WSDL description is that each method exposed from a given endpoint must be *uniquely named*. Thus, while method overloading works just fine as far as C# is concerned, the current web service specifications do not permit two identically named `InsertCar()` methods.

Fortunately, the `[OperationContract]` attribute supports a named property (`Name`) that allows you to specify how the C# method will be represented within a WSDL description. Given this, you can update the second version of `InsertCar()` as follows:

```
public interface IAutoLotService
{
    ...
    [OperationContract(Name = "InsertCarWithDetails")]
    void InsertCar(InventoryRecord car);
}
```

Implementing the Service Contract

Now rename `Service.cs` to `AutoLotService.cs`. The `AutoLotService` type implements the `IAutoLotService` interface as follows (be sure to import the `AutoLotConnectedLayer` and `System.Data` namespaces into this code file and update your connection string if required):

```
using AutoLotDAL.ConnectedLayer;
using System.Data;

public class AutoLotService : IAutoLotService
{
    private const string ConnString =
        @"Data Source=(local)\SQLEXPRESS;Initial Catalog=AutoLot"+
        ";Integrated Security=True";

    public void InsertCar(int id, string make, string color, string petname)
    {
        InventoryDAL d = new InventoryDAL();
        d.OpenConnection(ConnString);
        d.InsertAuto(id, color, make, petname);
        d.CloseConnection();
    }

    public void InsertCar(InventoryRecord car)
    {
        InventoryDAL d = new InventoryDAL();
        d.OpenConnection(ConnString);
        d.InsertAuto(car.ID, car.Color, car.Make, car.PetName);
        d.CloseConnection();
    }

    public InventoryRecord[] GetInventory()
    {
        // First, get the DataTable from the database.
        InventoryDAL d = new InventoryDAL();
        d.OpenConnection(ConnString);
        DataTable dt = d.GetAllInventoryAsDataTable();
        d.CloseConnection();
    }
}
```

```

// Now make a List<T> to contain the records.
List<InventoryRecord> records = new List<InventoryRecord>();

// Copy the data table into List<> of custom contracts.
DataTableReader reader = dt.CreateDataReader();
while (reader.Read())
{
    InventoryRecord r = new InventoryRecord();
    r.ID = (int)reader["CarID"];
    r.Color = ((string)reader["Color"]);
    r.Make = ((string)reader["Make"]);
    r.PetName = ((string)reader["PetName"]);
    records.Add(r);
}

// Transform List<T> to array of InventoryRecord types.
return (InventoryRecord[])records.ToArray();
}
}

```

There isn't too much to say about the preceding code. For the sake of simplicity, you hard-code the connection string value (which you might need to adjust based on your machine settings), rather than store it in your `Web.config` file. Given that your data access library does all the real work of communicating with the AutoLot database, all you need to do is pass the incoming parameters to the `InsertAuto()` method of the `InventoryDAL` class type. The only other point of interest is the act of mapping the `DataTable` object's values into a generic list of `InventoryRecord` types (using a `DataTableReader`) and then transforming the `List<T>` into an array of `InventoryRecord` types.

The Role of the *.svc File

When you create a web-centric WCF service, you will find your project contains a specific file with an `*.svc` file extension. This particular file is required for any WCF service hosted by IIS; it describes the name and location of the service implementation within the install point. Because you have changed the names of your starter files and WCF types, you must now update the contents of the `Service.svc` file as follows:

```

<%@ ServiceHost Language="C#" Debug="true"
    Service="AutoLotService" CodeBehind="~/App_Code/AutoLotService.cs" %>

```

Examining the Web.config File

The `Web.config` file of a WCF service created under HTTP will use a number of the WCF simplifications examined earlier in this chapter. As will be described in more detail during your examination of ASP.NET later in this book, the `Web.config` file serves a similar purpose to an executable's `*.config` file; however, it also controls a number of web-specific settings. For this example, notice that MEX is enabled, and you do not have to specify a custom `<endpoint>` manually.

```

<configuration>
...

  <system.serviceModel>
    <behaviors>
      <serviceBehaviors>
        <behavior>
          <!-- To avoid disclosing metadata information,
               set the value below to false and remove the
               metadata endpoint above before deployment -->
          <serviceMetadata httpGetEnabled="true" httpsGetEnabled="true" />
          <!-- To receive exception details in faults for debugging purposes,
               set the value below to true.
               Set to false before deployment to avoid
               disclosing exception information -->
          <serviceDebug includeExceptionDetailInFaults="false"/>
        </behavior>
      </serviceBehaviors>
    </behaviors>
    <serviceHostingEnvironment aspNetCompatibilityEnabled="true"
                               multipleSiteBindingsEnabled="true" />
  </system.serviceModel>

...
</configuration>

```

Testing the Service

Now you are free to build any sort of client to test your service, including passing in the endpoint of the *.svc file to the WcfTestClient.exe application.

```
WcfTestClient http://localhost/AutoLotWCFService/Service.svc
```

If you want to build a custom client application, you can use the Add Service Reference dialog box, as you did for the MagicEightBallServiceClient and MathClient project examples earlier in this chapter.

■ **Source Code** You can find the AutoLotService project located in the Chapter 25 subdirectory.

That wraps up your look at the Windows Communication Foundation API. Of course, there is much more to WCF than could be covered in this introductory chapter; however, if you understand the materials presented here, you are in great shape to seek out more details as you see fit. Be sure to consult the .NET Framework 4.6 SDK documentation if you want to learn more about WCF.

Summary

This chapter introduced you to Windows Communication Foundation (WCF), which represents the core distributed programming API under the .NET platform. As explained in this chapter, the major motivation behind WCF was to provide a unified object model that exposes a number of (previously unrelated) distributed computing APIs under a single umbrella. Furthermore, a WCF service is represented by specified addresses, bindings, and contracts (which you can remember easily by the friendly abbreviation ABC).

You also learned that a typical WCF application involves the use of three interrelated assemblies. The first assembly defines the service contracts and service types that represent the service's functionality. This assembly is then hosted by a custom executable, an IIS virtual directory, or a Windows service. Finally, the client assembly uses a generated code file that defines a proxy type (and settings within the application configuration file) to communicate with the remote type.

The chapter also examined how to use a number of WCF programming tools, such as `SvcConfigEditor.exe` (which allows you to modify *.config files), the `WcfTestClient.exe` application (to test a WCF service quickly), and various Visual Studio WCF project templates. You also learned about a number of configuration simplifications, including default endpoints and behaviors.

PART VII



Windows Presentation Foundation

CHAPTER 26



Introducing Windows Presentation Foundation and XAML

When version 1.0 of the .NET platform was released, programmers who needed to build graphical desktop applications made use of two APIs named Windows Forms and GDI+, packaged up primarily in the `System.Windows.Forms.dll` and `System.Drawing.dll` assemblies. While Windows Forms/GDI+ are excellent APIs for building traditional desktop GUIs, Microsoft shipped an alternative GUI desktop API named Windows Presentation Foundation (WPF) beginning with the release of .NET 3.0.

This initial WPF chapter begins by examining the motivation behind this new GUI framework, which will help you see the differences between the Windows Forms/GDI+ and WPF programming models. Next, you will examine the different types of WPF applications supported by the API, and come to know the role of several important classes, including `Application`, `Window`, `ContentControl`, `Control`, `UIElement`, and `FrameworkElement`. During this time, you will learn to intercept keyboard and mouse activities, define application-wide data, and other common WPF tasks using nothing but C# code.

This chapter will then introduce you to an XML-based grammar named *Extensible Application Markup Language* (XAML; pronounced “zammel”). Here, you will learn the syntax and semantics of XAML (including attached property syntax, and the role of type converters and markup extensions), and come to understand how to generate, load, and parse XAML at runtime. As well, you will learn how to integrate XAML data into a C# WPF code base (and the benefits of doing so).

This chapter wraps up by investigating the integrated WPF designers of Visual Studio. Here, you will build your own custom XAML editor/parser, which will illustrate how XAML can be manipulated at runtime to build dynamic user interfaces.

The Motivation Behind WPF

Over the years, Microsoft has created numerous graphical user interface toolkits (raw C/C++/Windows API development, VB6, MFC, etc.) to build desktop executables. Each of these APIs provided a code base to represent the basic aspects of a GUI application, including main windows, dialog boxes, controls, menu systems, and other basic necessities. With the initial release of the .NET platform, the Windows Forms API quickly became the preferred model for UI development, given its simple yet very powerful object model.

While many full-featured desktop applications have been successfully created using Windows Forms, the fact of the matter is that this programming model is rather *asymmetrical*. Simply put, `System.Windows.Forms.dll` and `System.Drawing.dll` do not provide direct support for many additional technologies required to build a feature-rich desktop application. To illustrate this point, consider the ad hoc nature of GUI desktop development before the release of WPF (see Table 26-1).

Table 26-1. *Pre-WPF Solutions to Desired Functionalities*

| Desired Functionality | Technology |
|----------------------------------|--|
| Building windows with controls | Windows Forms |
| 2D graphics support | GDI+ (<code>System.Drawing.dll</code>) |
| 3D graphics support | DirectX APIs |
| Support for streaming video | Windows Media Player APIs |
| Support for flow-style documents | Programmatic manipulation of PDF files |

As you can see, a Windows Forms developer must pull in types from a number of unrelated APIs and object models. While it is true that making use of these diverse APIs might look similar syntactically (it is just C# code, after all), you might also agree that each technology requires a radically different mind-set. For example, the skills required to create a 3D rendered animation using DirectX are completely different from those used to bind data to a grid. To be sure, it is very difficult for a Windows Forms programmer to master the diverse nature of each API.

Unifying Diverse APIs

WPF (introduced with .NET 3.0) was purposely created to merge these previously unrelated programming tasks into a single unified object model. Thus, if you need to author a 3D animation, you have no need to manually program against the DirectX API (although you could) because 3D functionality is baked directly into WPF. To see how well things have cleaned up, consider Table 26-2, which illustrates the desktop development model ushered in as of .NET 3.0.

Table 26-2. *.NET 3.0 Solutions to Desired Functionalities*

| Desired Functionality | Technology |
|----------------------------------|------------|
| Building forms with controls | WPF |
| 2D graphics support | WPF |
| 3D graphics support | WPF |
| Support for streaming video | WPF |
| Support for flow-style documents | WPF |

The obvious benefit here is that .NET programmers now have a single, *symmetrical* API for all common GUI desktop programming needs. After you become comfortable with the functionality of the key WPF assemblies and the grammar of XAML, you'll be amazed how quickly you can create very sophisticated UIs.

Providing a Separation of Concerns via XAML

Perhaps one of the most compelling benefits is that WPF provides a way to cleanly separate the look and feel of a GUI application from the programming logic that drives it. Using XAML, it is possible to define the UI of an application via XML *markup*. This markup (ideally generated using tools such as Microsoft Visual Studio or Microsoft Expression Blend) can then be connected to a related C# code file to provide the guts of the program's functionality.

■ **Note** XAML is not limited to WPF applications. Any application can use XAML to describe a tree of .NET objects, even if they have nothing to do with a visible user interface. For example, the Windows Workflow Foundation API uses a XAML-based grammar to define business processes and custom activities. As well, other .NET GUI frameworks such as Silverlight (on the wane, but still very much in use today), Windows Phone, and Windows 10 applications all make use of XAML.

As you dig into WPF, you might be surprised how much flexibility this “desktop markup” provides. XAML allows you to define not only simple UI elements (buttons, grids, list boxes, etc.) in markup, but also interactive 2D and 3D graphics, animations, data binding logic, and multimedia functionality (such as video playback).

XAML also makes it very easy to customize how a control should render out its visual appearance. For example, defining a circular button control that animates your company logo requires just a few lines of markup. As shown in Chapter 29, WPF controls can be modified through styles and templates, which allow you to change the overall look and feel of an application with minimum fuss and bother. Unlike Windows Forms development, the only compelling reason to build a custom WPF control from the ground up is if you need to change the *behaviors* of a control (e.g., add custom methods, properties, or events; subclass an existing control to override virtual members). If you simply need to change the *look and feel* of a control (again, such as a circular animated button), you can do so entirely through markup.

Providing an Optimized Rendering Model

GUI toolkits such as Windows Forms, MFC, or VB6 performed all graphical rendering requests (including the rendering of UI elements such as buttons and list boxes) using a low-level, C-based API (GDI), which has been part of the Windows OS for years. GDI provides adequate performance for typical business applications or simple graphical programs; however, if a UI application needed to tap into high-performance graphics, DirectX was required.

The WPF programming model is quite different in that GDI is *not* used when rendering graphical data. All rendering operations (e.g., 2D graphics, 3D graphics, animations, control rendering, etc.) now make use of the DirectX API. The first obvious benefit is that your WPF applications will automatically take advantage of hardware and software optimizations. As well, WPF applications can tap into very rich graphical services (blur effects, anti-aliasing, transparency, etc.) without the complexity of programming directly against the DirectX API.

■ **Note** Although WPF does push all rendering requests to the DirectX layer, I don't want to suggest that a WPF application will perform as fast as building an application using unmanaged C++ and DirectX directly. Although significant advances have been made in WPF in .NET 4.6, if you are intending to build a desktop application that requires the fastest possible execution speed (such as a 3D video game), unmanaged C++ and DirectX are still the best approach.

Simplifying Complex UI Programming

To recap the story thus far, Windows Presentation Foundation (WPF) is an API for building desktop applications that integrates various desktop APIs into a single object model and provides a clean separation of concerns via XAML. In addition to these major points, WPF applications also benefit from a very simple way to integrate services into your programs, which historically were quite complex to account for. The following is a quick rundown of the core WPF features:

- A number of layout managers (far more than Windows Forms) to provide extremely flexible control over placement and reposition of content.
- Use of an enhanced data-binding engine to bind content to UI elements in a variety of ways.
- A built-in style engine, which allows you to define “themes” for a WPF application.
- Use of vector graphics, which allows content to be automatically resized to fit the size and resolution of the screen hosting the application.
- Support for 2D and 3D graphics, animations, and video and audio playback.
- A rich typography API, such as support for XML Paper Specification (XPS) documents, fixed documents (WYSIWYG), flow documents, and document annotations (e.g., a Sticky Notes API).
- Support for interoperating with legacy GUI models (e.g., Windows Forms, ActiveX, and Win32 HWNDs). For example, you can incorporate custom Windows Forms controls into a WPF application, and vice versa.

Now that you have some idea of what WPF brings to the table, let’s look at the various types of applications that can be created using this API. Many of these features will be explored in detail in the chapters to come.

The Various Flavors of WPF

The WPF API can be used to build a variety of GUI-centric applications that basically differ in their navigational structure and deployment models. The sections that follow present a high-level tour through each option.

Traditional Desktop Applications

The first (and most familiar) option is to use WPF to build a traditional executable assembly that runs on a local machine. For example, you could use WPF to build a text editor, painting program, or multimedia program such as a digital music player, photo viewer, and so forth. Like any other desktop application, these *.exe files can be installed using traditional means (setup programs, Windows Installer packages, etc.) or via ClickOnce technology to allow desktop applications to be distributed and installed via a remote web server.

Programmatically speaking, this type of WPF application will make use (at a minimum) of the `Window` and `Application` class types, in addition to the expected set of dialog boxes, toolbars, status bars, menu systems, and other UI elements.

Now, you can certainly use WPF to build your basic business application that does not support any bells and whistles, but WPF really shines when you *do* incorporate such features. Consider Figure 26-1, which shows a WPF sample desktop application for viewing patient records in a medical environment.



Figure 26-1. This WPF desktop application makes use of several WPF APIs

Sadly, the printed page does not show the full feature set of this program. For example, if you were to see this application running, you would note that the upper right of the main window is displaying a real-time graph of the patient's sinus rhythm. If you click the Patient Details button on the lower right, several animations take place to flip, rotate, and transform the UI to the look and feel shown in Figure 26-2.

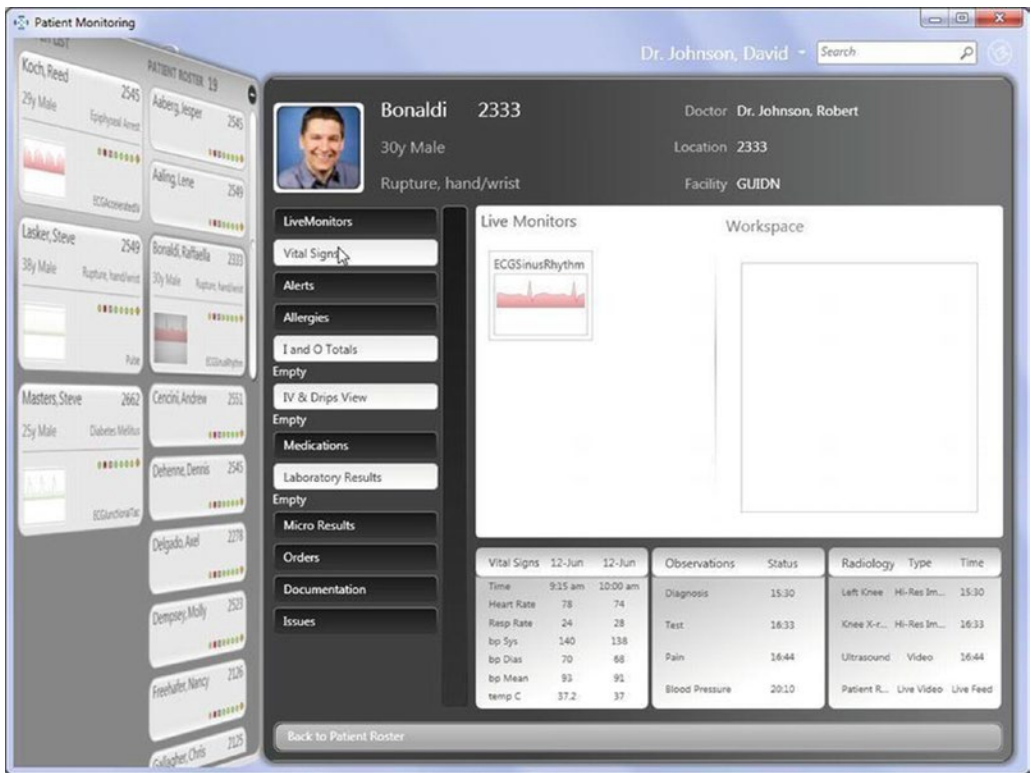

Figure 26-2. Transformations and animations are very simple under WPF

Could you build this same application without WPF? Absolutely. However, the amount of code—and the complexity of the code—would be much higher.

■ **Note** This example application, and many others, can be downloaded (with the source code) from the official WPF web site, <http://windowsclient.net>. Here, you will find numerous WPF (and Windows Forms) whitepapers, sample projects, technology walkthroughs, and forums. Unfortunately, at the time of this writing, there are only a scant few .NET 4.6 examples. The good news is that the XAML team is committed to updating the samples to .NET 4.6.

Navigation-Based WPF Applications

WPF applications can optionally choose to make use of a navigation-based structure, which makes a traditional desktop application take on the basic behavior of a web browser application. Using this model, you can build a desktop *.exe that provides a forward and back button that allows the end user to move back and forth between various UI displays called *pages*.

This type of application maintains a list of each page and provides the necessary infrastructure to navigate between them, pass data across pages (similar to a web-based application variable), and maintain a history list. By way of a concrete example, consider Windows Explorer (see Figure 26-3), which makes use of such functionality. Notice the navigation buttons mounted on the upper-left corner of the window.

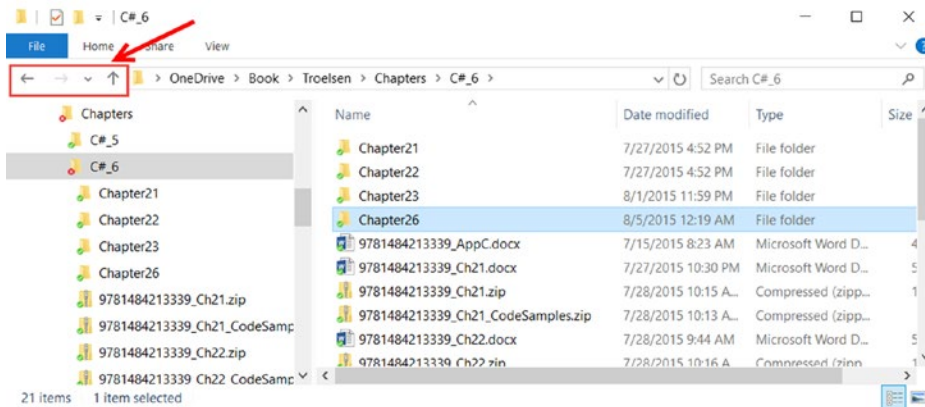

Figure 26-3. A navigation-based desktop program

Regardless of the fact that a WPF desktop application can take on a web-like navigational structure, understand that this is simply a UI design issue. The application itself is still just a local executable running on a desktop machine, and it has little to do with a web application beyond the option of adopting a slightly similar look and feel. Programmatically speaking, this type of WPF application is constructed using classes such as `Application`, `Page`, `NavigationWindow`, and `Frame`.

XBAP Applications

WPF also allows you to build applications that can be hosted *within* a web browser. This flavor of WPF application is termed a XAML *browser application*, or XBAP. Under this model, the end user navigates to a given URL, at which point the XBAP (which is essentially a collection of `Page` objects) is transparently downloaded and installed to the local machine. Unlike a traditional ClickOnce installation for an executable application, however, the XBAP program is hosted directly within the browser and adopts the browser's intrinsic navigational system. Figure 26-4 illustrates an XBAP program in action (specifically, the `ExpenseIt` WPF sample program, which can be found at <http://windowsclient.net>).

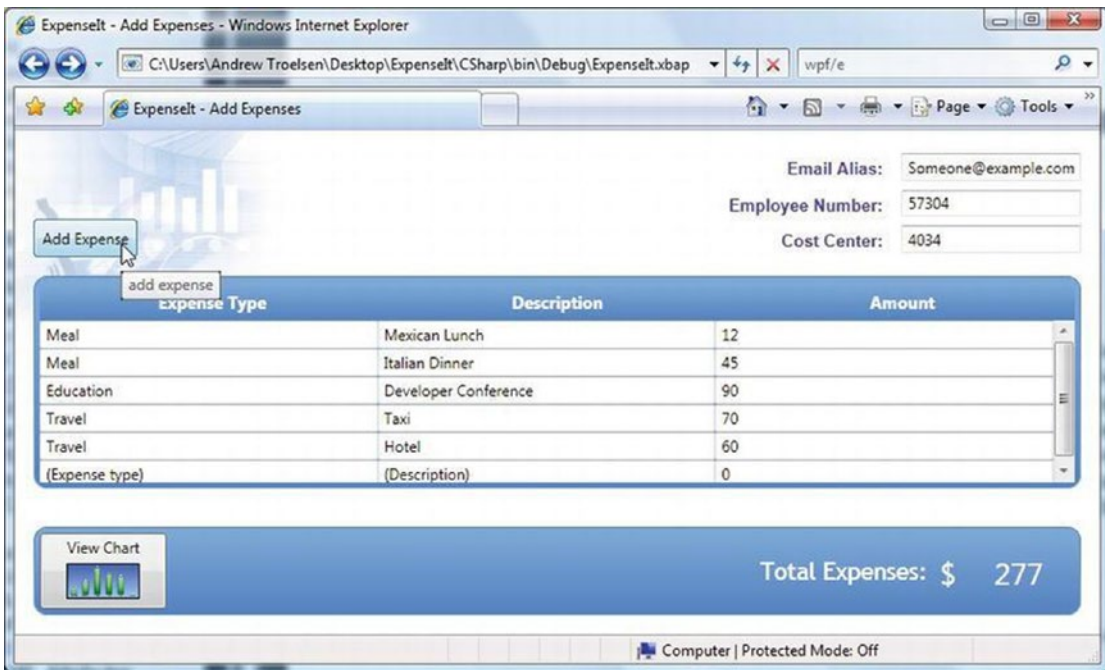

Figure 26-4. XBAP programs are downloaded to a local machine and hosted within a web browser

One benefit of an XBAP is that it allows you to create sophisticated UIs that are much more expressive than a typical web page built with HTML and JavaScript (however, HTML 5 certainly improves the current situation). An XBAP Page object can make use of the same WPF services as a desktop WPF application, including animations, 2D and 3D graphics, themes, and whatnot. In effect, the web browser is just a container for WPF Page objects, and is *not* displaying ASP.NET web pages.

However, given that these Page objects are deployed to a remote web server, XBAPs can be easily versioned and updated without the need to redeploy executables to the user's desktop. Like a traditional web program, you can simply update the Page objects in the web server, and the user will get the "latest and greatest" when they access the URL.

One downside to this flavor of WPF is that XBAPs must be hosted within Microsoft Internet Explorer or Firefox web browsers. Note that XBAPs are not supported on Microsoft Edge, the new Windows 10 browser; you must use Internet Explorer on Windows 10. If you are deploying XBAPs across a company intranet, browser compatibility should not be a problem, given that system administrators can play dictator regarding which browser should be installed on users' machines. However, if you want the outside world to make use of your XBAP, it is not possible to ensure that each end user is making use of Internet Explorer/Firefox, and therefore some external users may not be able to view your WPF XBAP.

Another issue to be aware of is that the machine that is viewing an XBAP must have a local installation of the .NET framework because the Page objects will be using the same .NET assemblies as an application running natively on the machine. Given this particular point, XBAPs are limited to Windows operating systems and, thus, cannot be viewed on a system running Mac OS X or Linux.

■ **Note** While you can still create XBAP projects in Visual Studio 2015, they are largely being replaced with HTML5/JavaScript-based applications (such as ASP.NET MVC).

The WPF/Silverlight Relationship

WPF and XAML also provided the foundation for the cross-platform, cross-browser WPF-based technology termed *Silverlight*. From a high level, you can consider Silverlight as a competitor to Adobe Flash, with the benefit of using C# and XAML rather than a new set of tools and languages. Silverlight is a subset of WPF functionality, which is used to build highly interactive plug-ins for a larger HTML-based web page. In reality, however, Silverlight is a completely unique distribution of the .NET platform, which ships with a “mini” CLR and “mini” version of the .NET base class libraries.

Unlike an XBAP, the user’s machine does not need a full installation of the .NET Framework. As long as the target machine has the Silverlight runtime installed, the browser will load the Silverlight runtime and display the Silverlight application automatically. Best of all, Silverlight plug-ins are not limited to the Windows operating systems. Microsoft has also created a Silverlight runtime for Mac OS X.

With Silverlight, you are able to build extremely feature-rich (and interactive) web applications. For example, like WPF, Silverlight has a vector-based graphical system, animation support, and multimedia support. Furthermore, you are able to incorporate a subset of the .NET base class library into your applications. This subset includes LINQ APIs, generic collections, support for WCF, and a healthy subset of `microsoft.dll` (file I/O, XML manipulation, etc.).

■ **Note** Microsoft is moving away from Silverlight as a development platform. While you can still create Silverlight projects in Visual Studio 2015, the need Silverlight once filled is largely being replaced with HTML5/JavaScript-based applications. Microsoft is committed to supporting Silverlight for 10 years after it was officially end-of-lived, which gives you about another 8 years (depending on when you read this book) of active support.

Investigating the WPF Assemblies

Regardless of which type of WPF application you want to build, WPF is ultimately little more than a collection of types bundled within .NET assemblies. Table 26-3 describes the key assemblies used to build WPF applications, each of which must be referenced when creating a new project. As you would hope, Visual Studio WPF projects reference these required assemblies automatically.

Table 26-3. Core WPF Assemblies

| Assembly | Meaning in Life |
|--|--|
| <code>PresentationCore.dll</code> | This assembly defines numerous namespaces that constitute the foundation of the WPF GUI layer. For example, this assembly contains support for the WPF Ink API (for programming against stylus input for Pocket PCs and Tablet PCs), animation primitives, and numerous graphical rendering types. |
| <code>PresentationFramework.dll</code> | This assembly contains a majority of the WPF controls, the <code>Application</code> and <code>Window</code> classes, support for interactive 2D graphics and numerous types used in data binding. |
| <code>System.Xaml.dll</code> | This assembly provides namespaces that allow you to program against a XAML document at runtime. By and large, this library is only useful if you are authoring WPF support tools or need absolute control over XAML at runtime. |
| <code>WindowsBase.dll</code> | This assembly defines types that constitute the infrastructure of the WPF API, including those representing WPF threading types, security types, various type converters, and support for <i>dependency properties</i> and <i>routed events</i> (described in Chapter 27). |

Collectively, these four assemblies define a number of new namespaces and hundreds of new .NET classes, interfaces, structures, enumerations, and delegates. While you should consult the .NET Framework 4.6 SDK documentation for complete details, Table 26-4 describes the role of some (but certainly not all) of the important namespaces.

Table 26-4. Core WPF Namespaces

| Namespace | Meaning in Life |
|---------------------------|--|
| System.Windows | This is the root namespace of WPF. Here, you will find core classes (such as <code>Application</code> and <code>Window</code>) that are required by any WPF desktop project. |
| System.Windows.Controls | Contains all of the expected WPF widgets, including types to build menu systems, tool tips, and numerous layout managers. |
| System.Windows.Data | Contains types to work with the WPF data-binding engine, as well as support for data-binding templates. |
| System.Windows.Documents | Contains types to work with the documents API, which allows you to integrate PDF-style functionality into your WPF applications, via the XML Paper Specification (XPS) protocol. |
| System.Windows.Ink | Provides support for the Ink API, which allows you to capture input from a stylus or mouse, respond to input gestures, and so forth. Very useful for Tablet PC programming; however, any WPF can make use of this API. |
| System.Windows.Markup | This namespace defines a number of types that allow XAML markup (and the equivalent binary format, BAML) to be parsed and processed programmatically. |
| System.Windows.Media | This is the root namespace to several media-centric namespaces. Within these namespaces you will find types to work with animations, 3D rendering, text rendering, and other multimedia primitives. |
| System.Windows.Navigation | This namespace provides types to account for the navigation logic employed by XAML browser applications (XBAPs) as well as standard desktop applications that require a navigational page model. |
| System.Windows.Shapes | Defines classes that allow you to render interactive 2D graphics that automatically respond to mouse input. |

To begin your journey into the WPF programming model, you'll examine two members of the `System.Windows` namespace that are commonplace to any traditional desktop development effort: `Application` and `Window`.

■ **Note** If you have created desktop UIs using the Windows Forms API, be aware that the `System.Windows.Forms.*` and `System.Drawing.*` assemblies are not related to WPF. These libraries represent the original .NET GUI toolkit, Windows Forms/GDI+.

The Role of the Application Class

The `System.Windows.Application` class represents a global instance of a running WPF application. This class supplies a `Run()` method (to start the application), a series of events that you are able to handle in order to interact with the application's lifetime (such as `Startup` and `Exit`), and a number of events that are specific to XAML browser applications (such as events that fire as a user navigates between pages). Table 26-5 details some of the key properties.

Table 26-5. *Key Properties of the Application Type*

| Property | Meaning in Life |
|------------|---|
| Current | This static property allows you to gain access to the running <code>Application</code> object from anywhere in your code. This can be very helpful when a window or dialog box needs to gain access to the <code>Application</code> object that created it, typically to access application-wide variables and functionality. |
| MainWindow | This property allows you to programmatically get or set the main window of the application. |
| Properties | This property allows you to establish and obtain data that is accessible throughout all aspects of a WPF application (windows, dialog boxes, etc.). |
| StartupUri | This property gets or sets a URI that specifies a window or page to open automatically when the application starts. |
| Windows | This property returns a <code>WindowCollection</code> type, which provides access to each window created from the thread that created the <code>Application</code> object. This can be very helpful when you want to iterate over each open window of an application and alter its state (such as minimizing all windows). |

Constructing an Application Class

Any WPF application will need to define a class that extends `Application`. Within this class, you will define your program's entry point (the `Main()` method), which creates an instance of this subclass and typically handles the `Startup` and `Exit` events. You will build a full example project in just a moment, but here is a quick example:

```
// Define the global application object
// for this WPF program.
class MyApp : Application
{
    [STAThread]
    static void Main(string[] args)
    {
        // Create the application object.
        MyApp app = new MyApp();

        // Register the Startup/Exit events.
        app.Startup += (s, e) => { /* Start up the app */ };
        app.Exit += (s, e) => { /* Exit the app */ };
    }
}
```

Within the Startup handler, you will most often process any incoming command-line arguments and launch the main window of the program. The Exit handler, as you would expect, is where you can author any necessary shutdown logic for the program (e.g., save user preferences, write to the Windows registry).

Enumerating the Windows Collection

Another interesting property exposed by `Application` is `Windows`, which provides access to a collection representing each window loaded into memory for the current WPF application. Recall that as you create new `Window` objects, they are automatically added into the `Application.Windows` collection. Here is an example method that will minimize each window of the application (perhaps in response to a given keyboard gesture or menu option triggered by the end user):

```
static void MinimizeAllWindows()
{
    foreach (Window wnd in Application.Current.Windows)
    {
        wnd.WindowState = WindowState.Minimized;
    }
}
```

You'll build a complete `Application`-derived type in an upcoming example. Until then, let's check out the core functionality of the `Window` type and learn about a number of important WPF base classes in the process.

The Role of the Window Class

The `System.Windows.Window` class (located in the `PresentationFramework.dll` assembly) represents a single window owned by the `Application`-derived class, including any dialog boxes displayed by the main window. Not surprisingly, `Window` has a series of parent classes, each of which brings more functionality to the table. Consider Figure 26-5, which shows the inheritance chain (and implemented interfaces) for `System.Windows.Window` as seen through the Visual Studio object browser.

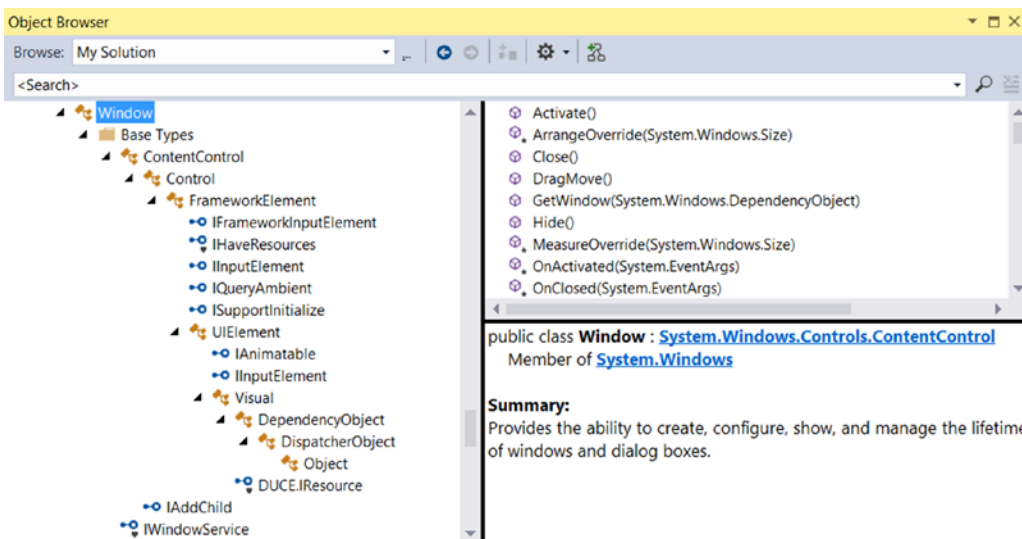

Figure 26-5. The hierarchy of the `Window` class

You'll come to understand the functionality provided by many of these base classes as you progress through this chapter and the chapters to come. However, to whet your appetite, the following sections present a breakdown of the functionality provided by each base class (consult the .NET Framework 4.6 SDK documentation for full details).

The Role of `System.Windows.Controls.ContentControl`

The direct parent of `Window` is `ContentControl`, which is quite possibly the most enticing of all WPF classes. This base class provides derived types with the ability to host a single piece of *content*, which, simply put, refers to the visual data placed within the interior of the control's surface area via the `Content` property. The WPF content model makes it very simple to customize the basic look and feel of a content control.

For example, when you think of a typical "button" control, you tend to assume that the content is a simple string literal (OK, Cancel, Abort, etc.). If you are using XAML to describe a WPF control, and the value you want to assign to the `Content` property can be captured as a simple string, you may set the `Content` property within the element's opening definition as so (don't fret over the exact markup at this point):

```
<!-- Setting the Content value in the opening element -->
<Button Height="80" Width="100" Content="OK"/>
```

■ **Note** The `Content` property can also be set in C# code, which allows you to change the interior of a control at runtime.

However, content can be almost anything. For example, let's say you want to have a "button" that has something more interesting than a simple string, perhaps a custom graphic and a blurb of text. In other UI frameworks such as Windows Forms, you would be required to build a custom control, which could entail quite a bit of code and a whole new class to maintain. With the WPF content model, there is no need to do so.

When you want to assign the `Content` property to a value that cannot be captured as a simple array of characters, you can't assign it using an attribute in the control's opening definition. Rather, you must define the content data *implicitly*, within the element's scope. For example, the following `<Button>` contains a `<StackPanel>` as content, which itself contains some unique data (an `<Ellipse>` and `<Label>`, to be exact):

```
<!-- Implicitly setting the Content property with complex data -->
<Button Height="80" Width="100">
  <StackPanel>
    <Ellipse Fill="Red" Width="25" Height="25"/>
    <Label Content ="OK!"/>
  </StackPanel>
</Button>
```

You can also make use of XAML's *property-element syntax* to set complex content. Consider the following functionally equivalent `<Button>` definition, which sets the `Content` property explicitly using property-element syntax (again, you'll find more information on XAML later in this chapter, so don't sweat the details just yet):

```
<!-- Setting the Content property using property-element syntax -->
<Button Height="80" Width="100">
  <Button.Content>
    <StackPanel>
      <Ellipse Fill="Red" Width="25" Height="25"/>
      <Label Content="OK!" />
    </StackPanel>
  </Button.Content>
</Button>
```

Do be aware that not every WPF element derives from `ContentControl` and, therefore, not all controls support this unique content model (however, most do). As well, some WPF controls add a few refinements to the basic content model you have just examined. Chapter 27 will examine the role of WPF content in much more detail.

The Role of System.Windows.Controls.Control

Unlike `ContentControl`, all WPF controls share the `Control` base class as a common parent. This base class provides numerous core members that account for basic UI functionality. For example, `Control` defines properties to establish the control's size, opacity, tab order logic, the display cursor, background color, and so forth. Furthermore, this parent class provides support for *templating services*. As explained in Chapter 29, WPF controls can completely change the way they render their appearance using templates and styles. Table 26-6 documents some key members of the `Control` type, grouped by related functionality.

Table 26-6. Key Members of the Control Type

| Members | Meaning in Life |
|---|---|
| Background, Foreground, BorderBrush, BorderThickness, Padding, HorizontalContentAlignment, VerticalContentAlignment | These properties allow you to set basic settings regarding how the control will be rendered and positioned. |
| FontFamily, FontSize, FontStretch, FontWeight | These properties control various font-centric settings. |
| IsTabStop, TabIndex | These properties are used to establish tab order among controls on a window. |
| MouseDoubleClick, PreviewMouseDoubleClick | These events handle the act of double-clicking a widget. |
| Template | This property allows you to get and set the control's template, which can be used to change the rendering output of the widget. |

The Role of System.Windows.FrameworkElement

This base class provides a number of members that are used throughout the WPF framework, such as support for storyboarding (used within animations) and support for data binding, as well as the ability to name a member (via the `Name` property), obtain any resources defined by the derived type, and establish the overall dimensions of the derived type. Table 26-7 hits the highlights.

Table 26-7. Key Members of the FrameworkElement Type

| Members | Meaning in Life |
|--|--|
| ActualHeight, ActualWidth, MaxHeight, MaxWidth, MinHeight, MinWidth, Height, Width | These properties control the size of the derived type. |
| ContextMenu | Gets or sets the pop-up menu associated with the derived type. |
| Cursor | Gets or sets the mouse cursor associated with the derived type. |
| HorizontalAlignment, VerticalAlignment | Gets or sets how the type is positioned within a container (such as a panel or list box). |
| Name | Allows to you assign a name to the type, in order to access its functionality in a code file. |
| Resources | Provides access to any resources defined by the type (see Chapter 29 for an examination of the WPF resource system). |
| ToolTip | Gets or sets the tool tip associated with the derived type. |

The Role of System.Windows.UIElement

Of all the types within a Window's inheritance chain, the `UIElement` base class provides the greatest amount of functionality. The key task of `UIElement` is to provide the derived type with numerous events to allow the derived type to receive focus and process input requests. For example, this class provides numerous events to account for drag-and-drop operations, mouse movement, keyboard input, and stylus input (for Pocket PCs and Tablet PCs).

Chapter 27 digs into the WPF event model in detail; however, many of the core events will look quite familiar (`MouseMove`, `KeyUp`, `MouseDown`, `MouseEnter`, `MouseLeave`, etc.). In addition to defining dozens of events, this parent class provides a number of properties to account for control focus, enabled state, visibility, and hit testing logic, as shown in Table 26-8.

Table 26-8. Key Members of the UIElement Type

| Members | Meaning in Life |
|----------------------------------|--|
| Focusable, IsFocused | These properties allow you to set focus on a given derived type. |
| IsEnabled | This property allows you to control whether a given derived type is enabled or disabled. |
| IsMouseDirectlyOver, IsMouseOver | These properties provide a simple way to perform hit-testing logic. |
| IsVisible, Visibility | These properties allow you to work with the visibility setting of a derived type. |
| RenderTransform | This property allows you to establish a transformation that will be used to render the derived type. |

The Role of System.Windows.Media.Visual

The `Visual` class type provides core rendering support in WPF, which includes hit testing of graphical data, coordinate transformation, and bounding box calculations. In fact, the `Visual` class interacts with the underlying DirectX subsystem to actually draw data on the screen. As you will examine in Chapter 28, WPF provides three possible manners in which you can render graphical data, each of which differs in terms of functionality and performance. Use of the `Visual` type (and its children, such as `DrawingVisual`) provides the most lightweight way to render graphical data, but it also entails the greatest amount of manual code to account for all the required services. Again, more details to come in Chapter 28.

The Role of System.Windows.DependencyObject

WPF supports a particular flavor of .NET properties termed *dependency properties*. Simply put, this style of property provides extra code to allow the property to respond to several WPF technologies such as styles, data binding, animations, and so forth. In order for a type to support this new property scheme, it will need to derive from the `DependencyObject` base class. While dependency properties are a key aspect of WPF development, much of the time their details are hidden from view. Chapter 27 dives further into the details of dependency properties.

The Role of System.Windows.Threading.DispatcherObject

The final base class of the `Window` type (beyond `System.Object`, which I assume needs no further explanation at this point in the book) is `DispatcherObject`. This type provides one property of interest, `Dispatcher`, which returns the associated `System.Windows.Threading.Dispatcher` object. The `Dispatcher` class is the entry point to the event queue of the WPF application, and it provides the basic constructs for dealing with concurrency and threading.

Building a WPF Application Without XAML

Given all of the functionality provided by the parent classes of the `Window` type, it is possible to represent a window in your application by either directly creating a `Window` object or using this class as the parent to a strongly typed descendant. Let's examine both approaches in the following code example. Although most WPF applications will make use of XAML, doing so is technically optional. Anything that can be expressed in XAML can be expressed in code and (for the most part) vice versa. If you so desire, it is possible to build a complete WPF project using the underlying object model and procedural C# code.

To illustrate, let's create a minimal but complete application *without* the use of XAML using the `Application` and `Window` classes directly. Begin by creating a new Console Application named `WpfAppAllCode` (don't worry; you will use the Visual Studio WPF project template later in this chapter). Go into the project properties and change the output type to `Windows Application` (this prevents the console window from popping up). Next, access the Project Add Reference dialog box and add a reference to `WindowsBase.dll`, `PresentationCore.dll`, `System.Xaml.dll`, and `PresentationFramework.dll`.

Now, update your initial C# file with the following code, which creates a window of modest functionality (here, I am only showing the namespaces that *must* be imported to compile the code; feel free to leave any auto-including `using` statements in place):

```
// A simple WPF application, written without XAML.
using System;
using System.Windows;
using System.Windows.Controls;
```



```

namespace WpfAppAllCode
{
    // In this first example, you are defining a single class type to
    // represent the application itself and the main window.
    class Program : Application
    {
        [STAThread]
        static void Main(string[] args)
        {
            // Handle the Startup and Exit events, and then run the application.
            Program app = new Program();
            app.Startup += AppStartUp;
            app.Exit += AppExit;
            app.Run(); // Fires the Startup event.
        }

        static void AppExit(object sender, ExitEventArgs e)
        {
            MessageBox.Show("App has exited");
        }

        static void AppStartUp(object sender, StartupEventArgs e)
        {
            // Create a Window object and set some basic properties.
            Window mainWindow = new Window();
            mainWindow.Title = "My First WPF App!";
            mainWindow.Height = 200;
            mainWindow.Width = 300;
            mainWindow.WindowStartupLocation = WindowStartupLocation.CenterScreen;
            mainWindow.Show();
        }
    }
}

```

■ **Note** The `Main()` method of a WPF application must be attributed with the `[STAThread]` attribute, which ensures any legacy COM objects used by your application are thread safe. If you do not annotate `Main()` in this way, you will encounter a runtime exception.

Note that the `Program` class extends the `System.Windows.Application` class. Within the `Main()` method, you create an instance of the application object and handle the `Startup` and `Exit` events using method group conversion syntax. Recall from Chapter 10 that this shorthand notation removes the need to manually specify the underlying delegates used by a particular event. Of course, if you want, you can specify the underlying delegates directly by name.

In the following modified `Main()` method, notice that the `Startup` event works in conjunction with the `StartupEventHandler` delegate, which can only point to methods taking an `Object` as the first parameter and a `StartupEventArgs` as the second. The `Exit` event, on the other hand, works with the `ExitEventHandler` delegate, which demands that the method pointed to take an `ExitEventArgs` type as the second parameter.

```
[STAThread]
static void Main(string[] args)
{
    // This time, specify the underlying delegates.
    Program app = new Program();
    app.Startup += new StartupEventHandler(AppStartup);
    app.Exit += new ExitEventHandler(AppExit);
    app.Run(); // Fires the Startup event.
}
```

In any case, the `AppStartup()` method has been configured to create a `Window` object, establish some very basic property settings, and call `Show()` to display the window on the screen in a modeless fashion (the `ShowDialog()` method can be used to launch a modal dialog). The `AppExit()` method simply makes use of the `WPF MessageBox` class to display a diagnostic message when the application is being terminated.

Once you compile and run the project, you will find a very simple main window that can be minimized, maximized, and closed. To spice things up a bit, you need to add some user interface elements. Before you do, however, you should refactor your code base to account for a strongly typed and well-encapsulated `Window`-derived class.

Creating a Strongly Typed Window

Currently, the `Application`-derived class directly creates an instance of the `Window` type upon application startup. Ideally, you would create a class deriving from `Window` in order to encapsulate its appearance and functionality. Add another class to your project named `MainWindow`, and add the following class definition (be sure to import the `System.Windows` namespace):

```
class MainWindow : Window
{
    public MainWindow(string windowTitle, int height, int width)
    {
        this.Title = windowTitle;
        this.WindowStartupLocation = WindowStartupLocation.CenterScreen;
        this.Height = height;
        this.Width = width;
    }
}
```

You can now update your `Startup` event handler to simply directly create an instance of `MainWindow`, like so:

```
static void AppStartup(object sender, StartupEventArgs e)
{
    // Create a MainWindow object.
    var main = new MainWindow("My better WPF App!", 200, 300);
    main.Show();
}
```

Once the program is recompiled and executed, the output is identical. The obvious benefit is that you now have a strongly typed class representing the main window to build upon.

■ **Note** When you create a `Window` (or `Window`-derived) object, it will automatically be added to the windows collection of the `Application` class (via some constructor logic found in the `Window` class itself). You can use the `Application.Windows` property to iterate over the list of `Window` objects currently in memory.

Creating a Simple User Interface

Adding a UI element (such as a `Button`) to a `Window` in `C#` code will involve the following basic steps:

1. Define a member variable to represent the control.
2. Configure the control's look and feel upon `Window` construction.
3. Assign the control to the inherited `Content` property, or alternatively, as a parameter to the inherited `AddChild()` method.

Recall that the WPF control content model demands that the `Content` property is set to a single element. Of course, a `Window` that contained only a single UI control would be quite useless. Therefore, in almost every case, the “single piece of content” that is assigned to the `Content` property is, in reality, a layout manager, such as `DockPanel`, `Grid`, `Canvas`, or `StackPanel`. Within the layout manager, you can have any combination of internal controls, including other nested layout managers. (Read more on this aspect of WPF development in Chapter 27.)

For now, you will add a single `Button` control to your `Window`-derived class. When you click the button, you will close the current window, which will indirectly terminate the application because you have no other windows in memory. Ponder the following update to the `MainWindow` class (be sure you have imported `System.Windows.Controls` to gain access to the `Button` class):

```
class MainWindow : Window
{
    // Our UI element.
    private Button btnExitApp = new Button();

    public MainWindow(string windowTitle, int height, int width)
    {
        // Configure button and set the child control.
        btnExitApp.Click += new RoutedEventHandler(btnExitApp_Clicked);
        btnExitApp.Content = "Exit Application";
        btnExitApp.Height = 25;
        btnExitApp.Width = 100;

        // Set the content of this window to a single button.
        this.Content = btnExitApp;

        // Configure the window.
        this.Title = windowTitle;
        this.WindowStartupLocation = WindowStartupLocation.CenterScreen;
        this.Height = height;
        this.Width = width;
        this.Show();
    }
}
```

```
private void btnExitApp_Clicked(object sender, RoutedEventArgs e)
{
    // Close the window.
    this.Close();
}
}
```

Notice that the Click event of the WPF Button works in conjunction with a delegate named RoutedEventHandler, which begs the question, what is a routed event? You'll examine the details of the WPF event model in the next chapter; for the time being, simply understand that targets of the RoutedEventHandler delegate must supply an object as the first parameter and a RoutedEventArgs as the second.

In any case, after you recompile and run this application, you will find the customized window shown in Figure 26-6. Notice that your button is automatically placed in the dead center of the window's client area; this is the default behavior when content is not placed within a WPF panel type.

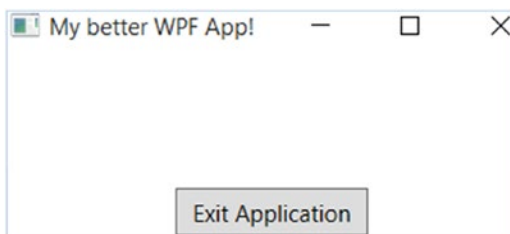

Figure 26-6. A simple WPF application written entirely in C# code

Interacting with Application-Level Data

Recall that the Application class defines a property named Properties, which allows you to define a collection of name/value pairs via a type indexer. Because this indexer has been defined to operate on type System.Object, you are able to store any sort of item within this collection (including your custom classes), to be retrieved at a later time using a friendly moniker. Using this approach, it is simple to share data across all windows in a WPF application.

To illustrate, you will update the current Startup event handler to check the incoming command-line arguments for a value named /GODMODE (a common cheat code for many PC video games). If you find this token, you will establish a bool value set to true within the properties collection of the same name (otherwise, you will set the value to false).

Sounds simple enough, but how are you going to pass the incoming command-line arguments (typically obtained from the Main() method) to your Startup event handler? One approach is to call the static Environment.GetCommandLineArgs() method. However, these same arguments are automatically added to the incoming StartupEventArgs parameter and can be accessed via the Args property. That being said, here is the first update to the current code base:

```
private static void AppStartup(object sender, StartupEventArgs e)
{
    // Check the incoming command-line arguments and see if they
    // specified a flag for /GODMODE.
}
```

```

Application.Current.Properties["GodMode"] = false;
foreach(string arg in e.Args)
{
    if (arg.ToLower() == "/godmode")
    {
        Application.Current.Properties["GodMode"] = true;
        break;
    }
}
// Create a MainWindow object.
MainWindow wnd = new MainWindow("My better WPF App!", 200, 300);
}

```

Application-wide data can be accessed from anywhere within the WPF application. All you are required to do is obtain an access point to the global application object (via `Application.Current`) and investigate the collection. For example, you could update the `Click` event handler of the `Button` as so:

```

private void btnExitApp_Clicked(object sender, RoutedEventArgs e)
{
    // Did user enable /godmode?
    if((bool)Application.Current.Properties["GodMode"])
    {
        MessageBox.Show("Cheater!");
    }
    this.Close();
}

```

With this, if the end user launches your program via

```
WpfAppAllCode.exe /godmode
```

he or she will see the shameful message box displayed when terminating the application.

■ **Note** Recall that you can supply command-line arguments within Visual Studio. Simply double-click the Properties icon within Solution Explorer, click the Debug tab from the resulting editor, and enter `/godmode` within the “Command line arguments” editor.

Handling the Closing of a Window Object

End users can shut down a window using numerous built-in system-level techniques (e.g., clicking the “X” close button on the window’s frame) or by indirectly calling the `Close()` method in response to some user interaction element (e.g., `File > Exit`). In either case, WPF provides two events that you can intercept to determine whether the user is *truly* ready to shut down the window and remove it from memory. The first event to fire is `Closing`, which works in conjunction with the `CancelEventHandler` delegate.

This delegate expects target methods to take `System.ComponentModel.CancelEventArgs` as the second parameter. `CancelEventArgs` provides the `Cancel` property, which when set to `true` will prevent the window from actually closing (this is handy when you have asked the user if he really wants to close the window or if perhaps he would like to save his work first).

If the user does indeed wish to close the window, `CancelEventArgs.Cancel` can be set to `false` (which is the default setting). This will then cause the `Closed` event to fire (which works with the `System.EventHandler` delegate), making it the point at which the window is about to be closed for good.

Update the `MainWindow` class to handle these two events by adding these code statements to the current constructor, like so:

```
public MainWindow(string windowTitle, int height, int width)
{
    ...
    this.Closing += MainWindow_Closing;
    this.Closed += MainWindow_Closed;
}
```

Now, implement the corresponding event handlers as so:

```
private void MainWindow_Closing(object sender,
    System.ComponentModel.CancelEventArgs e)
{
    // See if the user really wants to shut down this window.
    string msg = "Do you want to close without saving?";
    MessageBoxResult result = MessageBox.Show(msg,
        "My App", MessageBoxButton.YesNo, MessageBoxImage.Warning);

    if (result == MessageBoxResult.No)
    {
        // If user doesn't want to close, cancel closure.
        e.Cancel = true;
    }
}

private void MainWindow_Closed(object sender, EventArgs e)
{
    MessageBox.Show("See ya!");
}
```

Now, run your program and attempt to close the window, either by clicking the “X” icon on the upper right of the window or by clicking the button control. You should see the confirmation dialog shown in Figure 26-7.

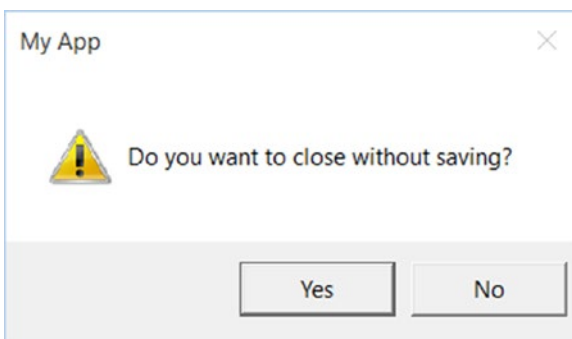

Figure 26-7. Trapping the closing event of a window

If you click the Yes button, the application will terminate; however, clicking the No button will keep the window in memory.

Intercepting Mouse Events

The WPF API provides a number of events you can capture in order to interact with the mouse. Specifically, the `UIElement` base class defines a number of mouse-centric events such as `MouseMove`, `MouseUp`, `MouseDown`, `MouseEnter`, `MouseLeave`, and so forth.

Consider, for example, the act of handling the `MouseMove` event. This event works in conjunction with the `System.Windows.Input.MouseEventHandler` delegate, which expects its target to take a `System.Windows.Input.MouseEventArgs` type as the second parameter. Using `MouseEventArgs`, you are able to extract out the (x, y) position of the mouse and other relevant details. Consider the following partial definition:

```
public class MouseEventArgs : EventArgs
{
    ...
    public Point GetPosition(IInputElement relativeTo);
    public MouseButtonState LeftButton { get; }
    public MouseButtonState MiddleButton { get; }
    public MouseDevice MouseDevice { get; }
    public MouseButtonState RightButton { get; }
    public StylusDevice StylusDevice { get; }
    public MouseButtonState XButton1 { get; }
    public MouseButtonState XButton2 { get; }
}
```

■ **Note** The `XButton1` and `XButton2` properties allow you to interact with “extended mouse buttons” (such as the “next” and “previous” buttons found on some mouse controls). These are often used to interact with a browser’s history list to navigate between visited pages.

The `GetPosition()` method allows you to get the (x, y) value relative to a UI element on the window. If you are interested in capturing the position relative to the activated window, simply pass in `this`. Handle the `MouseMove` event in the constructor of your `MainWindow` class, like so:

```
public MainWindow(string windowTitle, int height, int width)
{
    ...
    this.MouseMove += MainWindow_MouseMove;
}
```

Here is an event handler for `MouseMove` that will display the location of the mouse in the window’s title area (notice you are translating the returned `Point` type into a text value via `ToString()`):

```
private void MainWindow_MouseMove(object sender,
    System.Windows.Input.MouseEventArgs e)
{
    // Set the title of the window to the current (x,y) of the mouse.
    this.Title = e.GetPosition(this).ToString();
}
```

Intercepting Keyboard Events

Processing keyboard input for the focused window is also very straightforward. `UIElement` defines a number of events that you can capture to intercept keypresses from the keyboard on the active element (e.g., `KeyUp`, `KeyDown`). The `KeyUp` and `KeyDown` events both work with the `System.Windows.Input.KeyEventHandler` delegate, which expects the target's second event handler to be of type `KeyEventArgs`, which defines several public properties of interest, shown here:

```
public class KeyEventArgs : KeyboardEventArgs
{
    ...
    public bool IsDown { get; }
    public bool IsRepeat { get; }
    public bool IsToggled { get; }
    public bool IsUp { get; }
    public Key Key { get; }
    public KeyStates KeyStates { get; }
    public Key SystemKey { get; }
}
```

To illustrate handling the `KeyDown` event in the constructor of `MainWindow` (just like you did for the previous events), implement the following event handler that changes the content of the button with the currently pressed key:

```
private void MainWindow_KeyDown(object sender, System.Windows.Input.KeyEventArgs e)
{
    // Display key press on the button.
    btnExitApp.Content = e.Key.ToString();
}
```

Figure 26-8 shows the final product of your first WPF program.

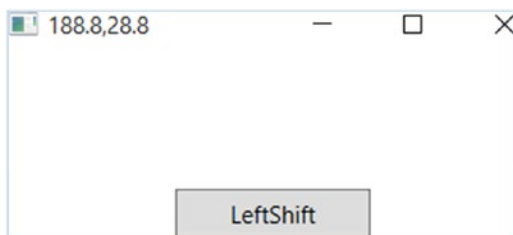

Figure 26-8. Your first WPF program, 100 percent XAML free

At this point in the chapter, WPF might look like nothing more than yet another GUI framework that is providing (more or less) the same services as Windows Forms, MFC, or VB6. If this were in fact the case, you might question the need for yet another UI toolkit. To truly see what makes WPF so unique requires an understanding of the XML-based grammar, XAML.

■ **Source Code** The `WpfAppAllCode` project is included in the Chapter 26 subdirectory.

Building a WPF Application Using Only XAML

A typical WPF application will *not* be composed exclusively of code, as you did in this first example. Rather, your C# code files will be paired with a related XAML source file, and together they represent the entirety of a given Window or Application, as well as other class types you have not yet examined, such as UserControl and Page.

This approach is termed the *code file approach* to building a WPF application, and you will make use of this technique extensively throughout the remainder of the book's WPF coverage. However, before you do, the next example will illustrate how to build a WPF application using nothing but XAML files. While this 100-percent XAML approach is not recommended, it will help you clearly understand how blobs of markup are transformed into a corresponding C# code base, and ultimately, a .NET assembly.

■ **Note** This next example will make use of a number of XAML techniques you have not yet formally examined, so don't become concerned if you encounter some unfamiliar syntax. You might want to simply load the solution files into a text editor and follow along; however, don't use Visual Studio to do so! Visual Studio will automatically make changes to the content, and interfere with the goal of this section. You will have *plenty* of time to use VS2015 to create WPF applications. Just not yet.

In general, XAML files will contain markup that describes the look and feel of the window, while the related C# code files contain the implementation logic. For example, the XAML file for a Window might describe the overall layout system, the controls within that layout system, and specify the names of various event handlers. The related C# file would contain the implementation logic of these event handlers and any custom code required by the application.

XAML is an XML-based grammar that allows you to define the state (and, to some extent, the functionality) of a tree of .NET objects through markup. While XAML is frequently used when building UIs with WPF, in reality it can be used to describe any tree of *nonabstract* .NET types (including your own custom types defined in a custom .NET assembly), provided each supports a default constructor. As you will see, the markup within a *.xaml file is transformed into a full-blown object model.

Because XAML is an XML-based grammar, we gain all the benefits (and drawbacks) XML affords us. On the plus side, XAML files are very self-describing (as any XML document should be). By and large, each element in a XAML file represents a type name (such as Button, Window, or Application) within a given .NET namespace. Attributes within the scope of an opening element map to properties (Height, Width, etc.) and events (Startup, Click, etc.) of the specified type.

Given the fact that XAML is simply a declarative way to define the state of an object, it is possible to define a WPF widget via markup or procedural code. For example, this XAML

```
<!-- Defining a WPF Button in XAML -->
<Button Name = "btnClickMe" Height = "40" Width = "100" Content = "Click Me" />
```

can be represented programmatically as

```
// Defining the same WPF Button in C# code.
Button btnClickMe = new Button();
btnClickMe.Height = 40;
btnClickMe.Width = 100;
btnClickMe.Content = "Click Me";
```

On the downside, XAML can be verbose and is (like any XML document) case sensitive. Thus, complex XAML definitions can result in a good deal of markup. Most developers will not need to manually author a complete XAML description of their WPF applications. Rather, the majority of this task will (thankfully) be relegated to development tools such as Visual Studio, Microsoft Expression Blend, or any number of third-party products. After the tools generate the basic markup, you can go in and fine-tune the XAML definitions by hand, if necessary.

Defining a Window Object in XAML

While tools can generate a good deal of XAML on your behalf, it is important for you to understand the basic workings of XAML syntax and how this markup is eventually transformed into a valid .NET assembly. To illustrate XAML in action, in the next example you'll build a WPF application using nothing more than a pair of *.xaml files.

The first Window-derived class (MainWindow) was defined in C# as a class type that extends the System.Windows.Window base class. This class contains a single Button object that calls a registered event handler when clicked. Defining this same Window type in the grammar of XAML can be achieved as follows. First, use a simple text editor (such as Notepad) to create a new file named MainWindow.xaml, and be sure to save this in an easily accessible subdirectory on your C: drive because you will be processing this file at the command line. Now, add the following XAML:

```
<!-- Here is your Window definition -->
<Window x:Class="WpfAppAllXaml.MainWindow"
  xmlns="http://schemas.microsoft.com/winfx/2006/xaml/presentation"
  xmlns:x="http://schemas.microsoft.com/winfx/2006/xaml"
  Title="A Window built using 100% XAML"
  Height="200" Width="300"
  WindowStartupLocation="CenterScreen">
  <Windows.Content>
    <!-- This window has a single button as content -->
    <Button x:Name="btnExitApp" Width="133" Height="24"
      Content="Close Window" Click="btnExitApp_Clicked"/>
  </Windows.Content>

<!-- The implementation of your button's Click event handler! -->
<x:Code>
  <![CDATA[
    private void btnExitApp_Clicked(object sender, RoutedEventArgs e)
    {
      this.Close();
    }
  ]]>
</x:Code>
</Window>
```

First, notice that the root element <Window> makes use of the Class attribute, which is used to specify the name of the C# class that will be generated when this XAML file is processed. Also notice that the Class attribute is prefixed with the x: tag prefix. If you look within the opening <Window> element, you'll see that this XML tag prefix is assigned to the string "http://schemas.microsoft.com/winfx/2006/xaml" to build an XML namespace declaration. You will understand the details of these XML namespace definitions a bit later in the chapter, but for now, just be aware that any time you want to make reference to an item defined by the "http://schemas.microsoft.com/winfx/2006/xaml" XAML namespace, you must prefix the x: token.

Within the scope of the `<Window>` start tag, you have specified values for the `Title`, `Height`, `Width`, and `WindowStartupLocation` attributes, which are a direct mapping to properties of the same name supported by the `System.Windows.Window` class in the `PresentationFramework.dll` assembly.

Next up, notice that within the scope of the window's definition, you have authored markup to describe the look and feel of a `Button` object that will be used to implicitly set the `Content` property of the window. Beyond setting up the variable name (using the `x:Name` XAML token) and its overall dimensions, you have also handled the `Click` event of the `Button` type by assigning the method to delegate to when the `Click` event occurs.

The final aspect of this XAML file is the `<x:Code>` element, which allows you to author event handlers and other methods of this class directly within an `*.xaml` file. As a safety measure, the code itself is wrapped within a `CDATA` scope to prevent XML parsers from attempting to directly interpret the data (although this is not strictly required for the current example).

It is important to point out that authoring functionality within a `<Code>` element is not recommended. Although this "single-file approach" isolates all the action to one location, inline code does not provide a clear separation of concerns between UI markup and programming logic. In most WPF applications, implementation code will be found within a related C# file (which you will do eventually).

Defining the Application Object in XAML

Remember that XAML can be used to define in markup any nonabstract .NET class that supports a default constructor. Given this, you could most certainly define your application object in markup as well. Consider the following content within a new file, `MyApp.xaml`:

```
<!-- The Main() method seems to be missing!
However, the StartupUri attribute is the
functional equivalent -->
<Application x:Class="WpfAppAllXaml.MyApp"
  xmlns="http://schemas.microsoft.com/winfx/2006/xaml/presentation"
  xmlns:x="http://schemas.microsoft.com/winfx/2006/xaml"
  StartupUri="MainWindow.xaml">
</Application>
```

Here, you might agree, the mapping between the `Application`-derived C# class type and its XAML description is not as clear-cut as was the case for your `MainWindow`'s XAML definition. Specifically, there does not seem to be any trace of a `Main()` method. Given that any .NET executable must have a program entry point, you are correct to assume it is generated at compile time, based in part on the `StartupUri` property. The value assigned to `StartupUri` represents which XAML resource to load when the application starts up. In this example, you have set the `StartupUri` property to the name of XAML resource defining your initial window object, `MainWindow.xaml`.

Although the `Main()` method is automatically created at compile time, you are free to use the `<x:Code>` element to capture other C# code blocks. For example, if you want to display a message when your program shuts down, you can handle the `Exit` event and implement it as so (note that the opening `<Application>` element has now set the `Exit` attribute to capture the `Exit` event of the `Application` class):

```
<Application x:Class="WpfAppAllXaml.MyApp"
  xmlns="http://schemas.microsoft.com/winfx/2006/xaml/presentation"
  xmlns:x="http://schemas.microsoft.com/winfx/2006/xaml"
  StartupUri="MainWindow.xaml" Exit="AppExit">
  <x:Code>
    <![CDATA[
      private void AppExit(object sender, ExitEventArgs e)
```

```

    {
        MessageBox.Show("App has exited");
    }
  ]]>
</x:Code>
</Application>

```

Processing the XAML Files Using msbuild.exe

At this point, you are ready to transform your markup into a valid .NET assembly. However, you cannot directly use the C# compiler to do so. To date, the C# compiler does not have a native understanding of XAML markup. However, the `msbuild.exe` command-line utility does understand how to transform XAML into C# code and compile this code on the fly when it is informed of the correct `*.targets` files.

`Msbuild.exe` is a tool that will compile .NET code based on the instructions contained within an XML-based build script. As it turns out, these build script files contain the exact same sort of data that is found in the `*.csproj` file generated by Visual Studio. Therefore, it is possible to compile a .NET program at the command line using `msbuild.exe` or using Visual Studio itself.

■ **Note** A full examination of the `msbuild.exe` utility is beyond the scope of this chapter. If you'd like to learn more, perform a search for the topic "MSBuild" in the .NET Framework 4.6 SDK documentation.

Here is a very simple build script, `WpfAppAllXaml.csproj`, which contains just enough information to inform `msbuild.exe` how to transform your XAML files into a related C# code base:

```

<Project DefaultTargets="Build"
  xmlns="http://schemas.microsoft.com/developer/msbuild/2003">
  <PropertyGroup>
    <RootNamespace>WpfAppAllXaml</RootNamespace>
    <AssemblyName>WpfAppAllXaml</AssemblyName>
    <OutputType>winexe</OutputType>
  </PropertyGroup>
  <ItemGroup>
    <Reference Include="System" />
    <Reference Include="System.Xaml" />
    <Reference Include="WindowsBase" />
    <Reference Include="PresentationCore" />
    <Reference Include="PresentationFramework" />
  </ItemGroup>
  <ItemGroup>
    <ApplicationDefinition Include="MyApp.xaml" />
    <Page Include="MainWindow.xaml" />
  </ItemGroup>
  <Import Project="$(MSBuildBinPath)\Microsoft.CSharp.targets" />
</Project>

```

■ **Note** This `*.csproj` file cannot be loaded directly into Visual Studio because it contains only the minimal instructions necessary to build your application at the command line.

The `<PropertyGroup>` element is used to specify some basic aspects of the build, such as the root namespace, the name of the resulting assembly, and the output type (the equivalent of the `/target:winexe` option of `csc.exe`).

The first `<ItemGroup>` specifies the set of external assemblies to reference with the current build, which, as you can see, are the core WPF assemblies examined earlier in this chapter.

The second `<ItemGroup>` is much more interesting. Notice that the `<ApplicationDefinition>` element's `Include` attribute is assigned to the `*.xaml` file that defines your application object. The `<Page>`'s `Include` attribute can be used to list each of the remaining `*.xaml` files that define the windows (and pages, which are often used when building XAML browser applications) processed by the application object.

However, the magic of this build script is the final `<Import>` element. Here, you are referencing `Microsoft.CSharp.Targets`, which contains data to interact with the C# compiler itself.

In any case, at this point you can use a developer command prompt to process your XAML data with `msbuild.exe`. To do so, change to the directory containing your `MainWindow.xaml`, `MyApp.xaml` and `WpfAppAllXaml.csproj` files, and enter the following command:

```
msbuild WpfAppAllXaml.csproj
```

After the build process has completed, you will find that your working directory now contains a `\bin` and `\obj` subdirectory (just like a Visual Studio project). If you were to open the `\bin\Debug` folder, you would find a new .NET assembly named `WpfAppAllXaml.exe`. If you open this assembly into `ildasm.exe`, you can see that your XAML has been transformed into a valid executable application (see Figure 26-9).

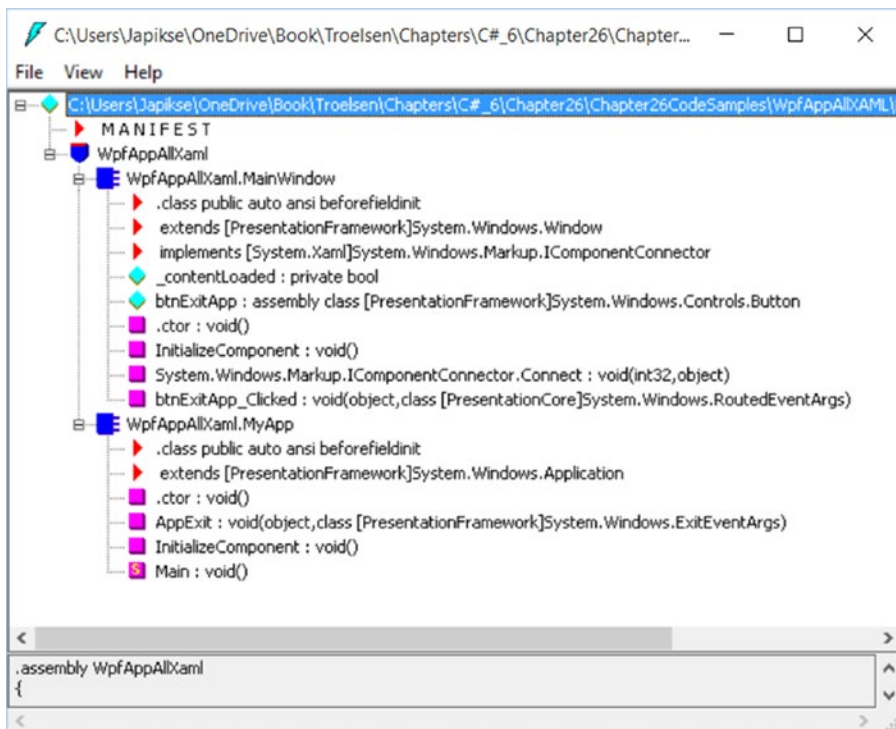

Figure 26-9. Transforming XAML into a .NET executable? Interesting . . .

And if you run your program by double-clicking the executable, you will see your main window launch on the screen.

Transforming Markup into a .NET Assembly

To understand exactly *how* your markup was transformed into a .NET assembly, you need to dig a bit deeper into the `msbuild.exe` process and examine a number of compiler-generated files, including a particular binary resource embedded within the assembly at compile time. The first task is to learn how your `*.xaml` files are transformed into a corresponding C# code base.

Mapping the Window XAML Markup to C# Code

The `*.targets` files specified in an `msbuild` script contain numerous instructions to translate XAML elements into C# code. When `msbuild.exe` processed your `*.csproj` file, it produced two files with the form of `*.g.cs` (where `g` denotes *autogenerated*) that were saved into the `\obj\Debug` directory. Based on the names of your `*.xaml` file names, the C# files in question are `MainWindow.g.cs` and `MyApp.g.cs`.

If you open the `MainWindow.g.cs` file into a text editor, you will find a class named `MainWindow`, which extends the `Window` base class. The name of this class is a direct result of the `x:Class` attribute in the `<Window>` start tag. This class also contains a member variable of type `System.Windows.Controls.Button`, named `btnExitApp`. In this case, the name of the control is based on the `x:Name` attribute value within the opening `<Button>` declaration. This class also contains the handler for the button's `Click` event, `btnExitApp_Clicked()`. Here is a partial listing of this compiler-generated `MainWindow.g.cs` file:

```
public partial class MainWindow :
    System.Windows.Window, System.Windows.Markup.IComponentConnector
{
    internal System.Windows.Controls.Button btnExitApp;

    private void btnExitApp_Clicked(object sender, RoutedEventArgs e)
    {
        this.Close();
    }
    ...
}
```

This class defines a private member variable of type `bool` (named `_contentLoaded`), which was not directly accounted for in the XAML markup. This data member is used to determine (and ensure) the content of the window is assigned only once.

```
public partial class MainWindow :
    System.Windows.Window, System.Windows.Markup.IComponentConnector
{
    // This member variable will be explained soon enough.
    private bool _contentLoaded;
    ...
}
```

Notice that the compiler-generated class also explicitly implements the WPF `IComponentConnector` interface defined in the `System.Windows.Markup` namespace. This interface defines a single method called `Connect()`, which has been implemented to prep each control defined in the markup and rig up the event logic as specified within the original `MainWindow.xaml` file. Before the method completes, the `_contentLoaded` member variable is set to `true`. Here is the crux of the method:

```
void System.Windows.Markup.IComponentConnector.Connect(int connectionId, object target)
{
    switch (connectionId)
    {
        case 1:
            this.btnExitApp = ((System.Windows.Controls.Button)(target));
            this.btnExitApp.Click += new
                System.Windows.RoutedEventHandler(this.btnExitApp_Clicked);
            return;
    }
    this._contentLoaded = true;
}
```

Last but not least, the `MainWindow` class also defines and implements a method named `InitializeComponent()`. You might expect that this method contains code that sets up the look and feel of each control by setting various properties (`Height`, `Width`, `Content`, etc.). However, this is not the case! How then do the controls take on the correct UI? The logic with `InitializeComponent()` resolves the location of an embedded assembly resource that is named identical to the original `*.xaml` file, like so:

```
public void InitializeComponent()
{
    if (_contentLoaded)
    {
        return;
    }
    _contentLoaded = true;
    System.Uri resourceLocator = new
        System.Uri("/WpfAppAllXaml;component/mainwindow.xaml",
            System.UriKind.Relative);
    System.Windows.Application.LoadComponent(this, resourceLocator);
}
```

At this point, the question becomes, *what exactly is this embedded resource?*

The Role of BAML

When `msbuild.exe` processed your `*.csproj` file, it generated a file taking a `*.baml` file extension. The full name of this file is named based on the initial `MainWindow.xaml` file. Therefore, you should see a file called `MainWindow.baml` in the `\obj\Debug` folder (see Figure 26-10).

| Name | Date modified | Type | Size |
|---|------------------|------------------------|-------|
| MainWindow.baml | 8/5/2015 9:28 PM | BAML File | 1 KB |
| MainWindow.g.cs | 8/5/2015 9:28 PM | Visual C# Source fi... | 4 KB |
| MyApp.g.cs | 8/5/2015 9:28 PM | Visual C# Source fi... | 3 KB |
| SimpleXamlApp.csproj.FileListAbsolute.txt | 8/5/2015 9:14 PM | TXT File | 1 KB |
| SimpleXamlApp.csprojResolveAssembly... | 8/5/2015 9:14 PM | CACHE File | 2 KB |
| WpfAppAllXaml.csproj.FileListAbsolute.txt | 8/5/2015 9:25 PM | TXT File | 2 KB |
| WpfAppAllXaml.csprojResolveAssembly... | 8/5/2015 9:23 PM | CACHE File | 2 KB |
| WpfAppAllXaml.exe | 8/5/2015 9:28 PM | Application | 7 KB |
| WpfAppAllXaml.g.resources | 8/5/2015 9:28 PM | RESOURCES File | 2 KB |
| WpfAppAllXaml.pdb | 8/5/2015 9:28 PM | Program Debug D... | 18 KB |
| WpfAppAllXaml_MarkupCompile.cache | 8/5/2015 9:28 PM | CACHE File | 1 KB |

Figure 26-10. BAML is simply a compact, binary version of XAML

As you might have guessed from the name, Binary Application Markup Language (BAML) is a compact, binary representation of the original XAML data. This *.baml file is embedded as a resource (via a generated *.g.resources file) into the compiled assembly.

This BAML resource contains all of the data needed to establish the look and feel of the UI widgets (again, such as the Height and Width properties).

The important take-away here is to understand that a WPF application contains within itself a binary representation (the BAML) of the markup. At runtime, this BAML will be plucked out of the resource container and used to make sure all windows and controls are initialized to the correct look and feel.

Also, remember that the name of these binary resources are *identical* to the name of the stand-alone *.xaml files you authored. However, this does not imply in any way that you must distribute the loose *.xaml files with your compiled WPF program. Unless you build a WPF application that will dynamically load and parse *.xaml files at runtime, you will never need to ship the original markup.

Mapping the Application XAML Markup to C# Code

The final piece of the autogenerated code to examine is the MyApp.g.cs file. Here, you see your Application-derived class with a proper Main() entry point method. The implementation of this method calls InitializeComponent() on the Application-derived type, which, in turn, sets the StartupUri property, allowing each of the objects to establish its correct property settings based on the binary XAML definition.

```
namespace WpfAppAllXaml
{
    public partial class MyApp : System.Windows.Application
    {
        void AppExit(object sender, ExitEventArgs e)
        {
            MessageBox.Show("App has exited");
        }
        [System.Diagnostics.DebuggerNonUserCodeAttribute()]
        public void InitializeComponent()
```



```

{
    this.Exit += new System.Windows.ExitEventHandler(this.AppExit);
    this.StartupUri = new System.Uri("MainWindow.xaml", System.UriKind.Relative);
}

[System.STAThreadAttribute()]
[System.Diagnostics.DebuggerNonUserCodeAttribute()]
public static void Main() {
    WpfAppAllXaml.MyApp app = new WpfAppAllXaml.MyApp();
    app.InitializeComponent();
    app.Run();
}
}
}

```

XAML-to-Assembly Process Summary

So at this point in the chapter, you have created a full-blown WPF program using nothing but two XAML files and a related build script. As you have seen, `msbuild.exe` leverages auxiliary settings defined within the `*.targets` file to process the XAML files (and generate the `*.baml`) for the build process. Figure 26-11 illustrates the overall picture regarding the compile-time processing of `*.xaml` files.

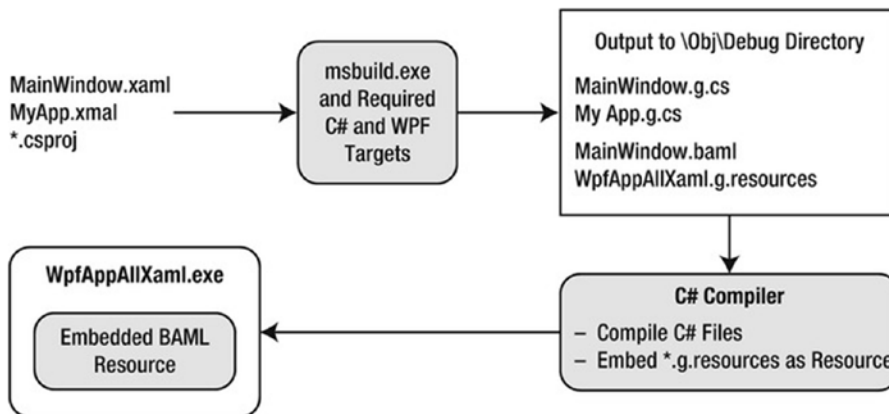

Figure 26-11. The XAML-to-assembly compile-time process

Hopefully you now have a much better idea how XAML data is used to build a .NET application. At this point, you are ready to take a look at the syntax and semantics of XAML itself.

■ **Source Code** The `WpfAppAllXaml` project can be found in the Chapter 26 subdirectory.

Understanding the Syntax of WPF XAML

Production-level WPF applications will typically make use of dedicated tools to generate the necessary XAML. As helpful as these tools are, it is a very good idea to have an understanding of the overall structure of XAML markup. To help in your learning process, allow me to introduce a very popular (and free) tool that allows you to easily experiment with XAML.

Introducing Kaxaml

When you are first learning the grammar of XAML, it can be very helpful to use a free tool named *Kaxaml*. You can obtain this popular XAML editor/parser from the following web site:

<http://www.kaxaml.com>

Kaxaml is helpful in that it has no clue about C# source code, event handlers, or implementation logic. It is a much more straightforward way to test XAML snippets than using a full-blown Visual Studio WPF project template. As well, Kaxaml has a number of integrated tools, such as a color chooser, XAML snippet manager, and even an “XAML scrubber” option that will format your XAML based on your settings. When you first open Kaxaml, you will find simple markup for a <Page> control, as follows:

```
<Page
  xmlns="http://schemas.microsoft.com/winfx/2006/xaml/presentation"
  xmlns:x="http://schemas.microsoft.com/winfx/2006/xaml">
  <Grid>

  </Grid>
</Page>
```

Like a Window, a Page contains various layout managers and controls. However, unlike a Window, Page objects cannot run as stand-alone entities. Rather, they must be placed inside a suitable host such as a NavigationWindow, Frame, or a web browser (and in that case, you have just made an XBAP!). The good news is that you can type identical markup within a <Page> or <Window> scope.

■ **Note** If you change the <Page> and </Page> elements in the Kaxaml markup window to <Window> and </Window>, you can press the F5 key to load a new window onto the screen.

As an initial test, enter the following markup into the XAML pane at the bottom of the tool:

```
<Page
  xmlns="http://schemas.microsoft.com/winfx/2006/xaml/presentation"
  xmlns:x="http://schemas.microsoft.com/winfx/2006/xaml">
  <Grid>
    <!-- A button with custom content -->
    <Button Height="100" Width="100">
      <Ellipse Fill="Green" Height="50" Width="50"/>
    </Button>
  </Grid>
</Page>
```

You should now see your page render at the upper part of the Kaxaml editor (see Figure 26-12).

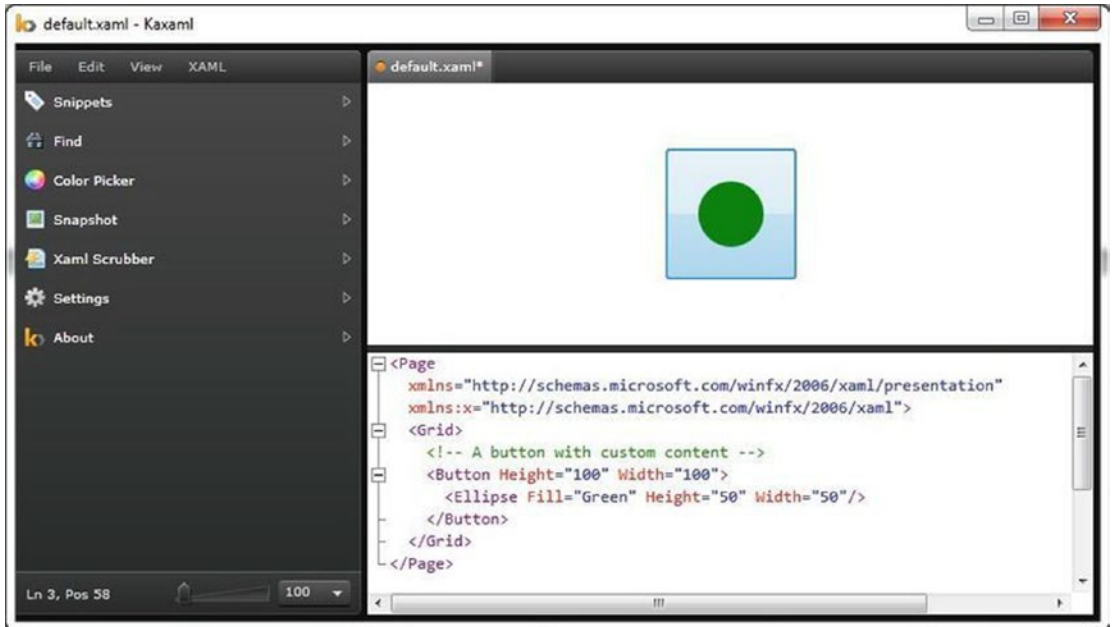

Figure 26-12. Kaxaml is a very helpful (and free) tool used to learn the grammar of XAML

As you work with Kaxaml, remember that this tool does not allow you to author any markup that entails code compilation (however, using `x:Name` is allowed). This includes defining a `x:Class` attribute (for specifying a code file), entering event handler names in markup, or using any XAML keywords that also entail code compilation (such as `FieldModifier` or `ClassModifier`). Any attempt to do so will result in a markup error.

XAML XML Namespaces and XAML “Keywords”

The root element of a WPF XAML document (such as a `<Window>`, `<Page>`, `<UserControl>`, or `<Application>` definition) will almost always make reference to the following two predefined XML namespaces:

```

<Page
  xmlns="http://schemas.microsoft.com/winfx/2006/xaml/presentation"
  xmlns:x="http://schemas.microsoft.com/winfx/2006/xaml">
  <Grid>

  </Grid>
</Page>
  
```

The first XML namespace, <http://schemas.microsoft.com/winfx/2006/xaml/presentation>, maps a slew of WPF .NET namespaces for use by the current *.xaml file (`System.Windows`, `System.Windows.Controls`, `System.Windows.Data`, `System.Windows.Ink`, `System.Windows.Media`, `System.Windows.Navigation`, etc.).

This one-to-many mapping is actually hard-coded within the WPF assemblies (WindowsBase.dll, PresentationCore.dll, and PresentationFramework.dll) using the assembly-level [XmlnsDefinition] attribute. For example, if you open the Visual Studio object browser and select the PresentationCore.dll assembly, you will see listings such as the following, which essentially imports System.Windows:

```
[assembly: XmlnsDefinition("http://schemas.microsoft.com/winfx/2006/xaml/presentation",
    "System.Windows")]
```

The second XML namespace, <http://schemas.microsoft.com/winfx/2006/xaml>, is used to include XAML-specific “keywords” (for lack of a better term) as well as the inclusion of the System.Windows.Markup namespace, as follows:

```
[assembly: XmlnsDefinition("http://schemas.microsoft.com/winfx/2006/xaml",
    "System.Windows.Markup")]
```

One rule of any well-formed XML document (remember, XAML is an XML-based grammar) is that the opening root element designates one XML namespace as the *primary namespace*, which typically is the namespace that contains the most commonly used items. If a root element requires the inclusion of additional secondary namespaces (as seen here), they must be defined using a unique tag prefix (to resolve any possible name clashes). As a convention, the prefix is simply x; however, this can be any unique token you require, such as XamlSpecificStuff.

```
<Page
  xmlns="http://schemas.microsoft.com/winfx/2006/xaml/presentation"
  xmlns:XamlSpecificStuff="http://schemas.microsoft.com/winfx/2006/xaml">
  <Grid>
    <!-- A button with custom content -->
    <Button XamlSpecificStuff:Name="button1" Height="100" Width="100">
      <Ellipse Fill="Green" Height="50" Width="50"/>
    </Button>
  </Grid>
</Page>
```

The obvious downside of defining wordy XML namespace prefixes is you are required to type XamlSpecificStuff each time your XAML file needs to refer to one of the items defined within this XAML-centric XML namespace. Given that XamlSpecificStuff requires many additional keystrokes, just stick with x.

In any case, beyond the x:Name, x:Class and x:Code keywords, the <http://schemas.microsoft.com/winfx/2006/xaml> XML namespace also provides access to additional XAML keywords, the most common of which are shown in Table 26-9.

Table 26-9. XAML Keywords

| XAML Keyword | Meaning in Life |
|-----------------|--|
| x:Array | Represents a .NET array type in XAML. |
| x:ClassModifier | Allows you to define the visibility of the C# class (internal or public) denoted by the Class keyword. |
| x:FieldModifier | Allows you to define the visibility of a type member (internal, public, private, or protected) for any named subelement of the root (e.g., a <Button> within a <Window> element). A <i>named element</i> is defined using the Name XAML keyword. |
| x:Key | Allows you to establish a key value for a XAML item that will be placed into a dictionary element. |
| x:Name | Allows you to specify the generated C# name of a given XAML element. |
| x:Null | Represents a null reference. |
| x:Static | Allows you to make reference to a static member of a type. |
| x:Type | The XAML equivalent of the C# typeof operator (it will yield a System.Type based on the supplied name). |
| x:TypeArguments | Allows you to establish an element as a generic type with a specific type parameter (e.g., List<int> vs. List<bool>). |

In addition to these two necessary XML namespace declarations, it is possible, and sometimes necessary, to define additional tag prefixes in the opening element of a XAML document. You will typically do so whenever you need to describe in XAML a .NET class defined in an external assembly.

For example, say you have built a few custom WPF controls and packaged them in a library named `MyControls.dll`. Now, if you want to create a new `Window` that uses these controls, you can establish a custom XML namespace that maps to your library using the `clr-namespace` and `assembly` tokens. Here is some example markup that creates a tag prefix named `myCtrls`, which can be used to access controls in your library:

```
<Window x:Class="WpfApplication1.MainWindow"
  xmlns="http://schemas.microsoft.com/winfx/2006/xaml/presentation"
  xmlns:x="http://schemas.microsoft.com/winfx/2006/xaml"
  xmlns:myCtrls="clr-namespace:MyControls;assembly=MyControls"
  Title="MainWindow" Height="350" Width="525">
  <Grid>
    <myCtrls:MyCustomControl />
  </Grid>
</Window>
```

The `clr-namespace` token is assigned to the name of the .NET namespace in the assembly, while the `assembly` token is set to the friendly name of the external *.dll assembly. You can use this syntax for any external .NET library you would like to manipulate in markup. While there is no need to do so at the current time, future chapters will require you to define custom XML namespace declarations to describe types in markup.

■ **Note** If you need to define a class in markup that is part of the current assembly, but in a different .NET namespace, your `xmlns` tag prefix is defined without the `assembly=` attribute, like so:

```
xmlns:myCtrls="clr-namespace:SomeNamespaceInMyApp"
```

Controlling Class and Member Variable Visibility

You will see many of these keywords in action where required in the chapters to come; however, by way of a simple example, consider the following XAML `<Window>` definition that makes use of the `ClassModifier` and `FieldModifier` keywords, as well as `x>Name` and `x:Class` (remember that `kaxaml.exe` will not allow you to make use of any XAML keyword that entails code compilation, such as `x:Code`, `x:FieldModifier`, or `x:ClassModifier`):

```
<!-- This class will now be declared internal in the *.g.cs file -->
<Window x:Class="MyWPFApp.MainWindow" x:ClassModifier="internal"
  xmlns="http://schemas.microsoft.com/winfx/2006/xaml/presentation"
  xmlns:x="http://schemas.microsoft.com/winfx/2006/xaml">

  <!-- This button will be public in the *.g.cs file -->
  <Button x>Name="myButton" x:FieldModifier="public" Content="OK"/>
</Window>
```

By default, all C#/XAML type definitions are public, while members default to internal. However, based on your XAML definition, the resulting autogenerated file contains an internal class type with a public `Button` variable.

```
internal partial class MainWindow : System.Windows.Window,
  System.Windows.Markup.IComponentConnector
{
  public System.Windows.Controls.Button myButton;
  ...
}
```

XAML Elements, XAML Attributes, and Type Converters

After you have established your root element and any required XML namespaces, your next task is to populate the root with a *child element*. In a real-world WPF application, the child will be a layout manager (such as a `Grid` or `StackPanel`) that contains, in turn, any number of additional UI elements that describe the user interface. The next chapter examines these layout managers in detail, so for now just assume that your `<Window>` type will contain a single `Button` element.

As you have already seen over the course of this chapter, XAML *elements* map to a class or structure type within a given .NET namespace, while the *attributes* within the opening element tag map to properties or events of the type. To illustrate, enter the following `<Button>` definition into Kaxaml:

```
<Page
  xmlns="http://schemas.microsoft.com/winfx/2006/xaml/presentation"
  xmlns:x="http://schemas.microsoft.com/winfx/2006/xaml">
  <Grid>
    <!-- Configure the look and feel of a Button -->
    <Button Height="50" Width="100" Content="OK!"
      FontSize="20" Background="Green" Foreground="Yellow"/>
  </Grid>
</Page>
```

Notice that the values assigned to each property have been captured as a simple text value. This may seem like a complete mismatch of data types because if you were to make this `Button` in C# code, you would *not* assign string objects to these properties but would make use of specific data types. For example, here is the same button authored in code:

```
public void MakeAButton()
{
    Button myBtn = new Button();
    myBtn.Height = 50;
    myBtn.Width = 100;
    myBtn.FontSize = 20;
    myBtn.Content = "OK!";
    myBtn.Background = new SolidColorBrush(Colors.Green);
    myBtn.Foreground = new SolidColorBrush(Colors.Yellow);
}
```

As it turns out, WPF ships with a number of *type converter* classes, which will be used to transform simple text values into the correct underlying data type. This process happens transparently (and automatically).

While this is all well and good, there will be many times when you need to assign a much more complex value to a XAML attribute, which cannot be captured as a simple string. For example, let's say you want to build a custom brush to set the `Background` property of the `Button`. If you are building the brush in code, it is quite straightforward, as seen here:

```
public void MakeAButton()
{
    ...
    // A fancy brush for the background.
    LinearGradientBrush fancyBrush =
        new LinearGradientBrush(Colors.DarkGreen, Colors.LightGreen, 45);
    myBtn.Background = fancyBrush;
    myBtn.Foreground = new SolidColorBrush(Colors.Yellow);
}
```

How, however, can you represent your complex brush as a string? Well, you can't! Thankfully, XAML provides a special syntax that can be used whenever you need to assign a property value to a complex object, termed *property-element syntax*.

Understanding XAML Property-Element Syntax

Property-element syntax allows you to assign complex objects to a property. Here is a XAML description for a `Button` that makes use of a `LinearGradientBrush` to set its `Background` property:

```
<Button Height="50" Width="100" Content="OK!"
        FontSize="20" Foreground="Yellow">
  <Button.Background>
    <LinearGradientBrush>
      <GradientStop Color="DarkGreen" Offset="0"/>
      <GradientStop Color="LightGreen" Offset="1"/>
    </LinearGradientBrush>
  </Button.Background>
</Button>
```

Notice that within the scope of the `<Button>` and `</Button>` tags, you have defined a subscope named `<Button.Background>`. Within this scope, you have defined a custom `<LinearGradientBrush>`. (Don't worry about the exact code for the brush; you'll learn about WPF graphics in Chapter 28.)

Generally speaking, any property can be set using property-element syntax, which always breaks down to the following pattern:

```
<DefiningClass>
  <DefiningClass.PropertyOnDefiningClass>
    <!-- Value for Property here! -->
  </DefiningClass.PropertyOnDefiningClass>
</DefiningClass>
```

While any property *could* be set using this syntax, if you can capture a value as a simple string, you will save yourself typing time. For example, here is a much more verbose way to set the `Width` of your `Button`:

```
<Button Height="50" Content="OK!"
        FontSize="20" Foreground="Yellow">
...
  <Button.Width>
    100
  </Button.Width>
</Button>
```

Understanding XAML Attached Properties

In addition to property-element syntax, XAML defines a special syntax used to set a value to an *attached property*. Essentially, an attached property allows a child element to set the value for a property that is actually defined in a parent element. The general template to follow looks like this:

```
<ParentElement>
  <ChildElement ParentElement.PropertyOnParent = "Value">
</ParentElement>
```

The most common use of attached property syntax is to position UI elements within one of the WPF layout manager classes (`Grid`, `DockPanel`, etc.). The next chapter dives into these panels in some detail; for now, enter the following in Kaxaml:

```
<Page
  xmlns="http://schemas.microsoft.com/winfx/2006/xaml/presentation"
  xmlns:x="http://schemas.microsoft.com/winfx/2006/xaml">
  <Canvas Height="200" Width="200" Background="LightBlue">
    <Ellipse Canvas.Top="40" Canvas.Left="40" Height="20" Width="20" Fill="DarkBlue"/>
  </Canvas>
</Page>
```

Here, you have defined a `Canvas` layout manager that contains an `Ellipse`. Notice that the `Ellipse` is able to inform its parent (the `Canvas`) where to position its top/left position using attached property syntax.

There are a few items to be aware of regarding attached properties. First and foremost, this is not an all-purpose syntax that can be applied to *any* property of *any* parent. For example, the following XAML cannot be parsed without error:

```
<!-- Error! Set Background property on Canvas via attached property? -->
<Canvas Height="200" Width="200">
  <Ellipse Canvas.Background="LightBlue"
    Canvas.Top="40" Canvas.Left="90"
    Height="20" Width="20" Fill="DarkBlue"/>
</Canvas>
```

In reality, attached properties are a specialized form of a WPF-specific concept termed a *dependency property*. Unless a property was implemented in a very specific manner, you cannot set its value using attached property syntax. You will explore dependency properties in a detail in Chapter 27.

■ **Note** Kaxaml, Visual Studio, and Expression Blend (a free companion tool that ships with Visual Studio 2015 and is useful for editing XAML based applications) all have IntelliSense, which will show you valid attached properties that can be set by a given element.

Understanding XAML Markup Extensions

As explained, property values are most often represented using a simple string or via property-element syntax. There is, however, another way to specify the value of a XAML attribute, using *markup extensions*. Markup extensions allow a XAML parser to obtain the value for a property from a dedicated, external class. This can be very beneficial, given that some property values require a number of code statements to execute to figure out the value.

Markup extensions provide a way to cleanly extend the grammar of XAML with new functionality. A markup extension is represented internally as a class that derives from `MarkupExtension`. Note that the chances of you ever needing to build a custom markup extension will be slim to none. However, a subset of XAML keywords (such as `x:Array`, `x:Null`, `x:Static`, and `x:Type`) are markup extensions in disguise!

A markup extension is sandwiched between curly brackets, like so:

```
<Element PropertyToSet = "{MarkupExtension}"/>
```

To see some markup extensions in action, author the following into Kaxaml:

```
<Page
  xmlns="http://schemas.microsoft.com/winfx/2006/xaml/presentation"
  xmlns:x="http://schemas.microsoft.com/winfx/2006/xaml"
  xmlns:CorLib="clr-namespace:System;assembly=mscorlib">
  <StackPanel>
    <!-- The Static markup extension lets us obtain a value
      from a static member of a class -->
    <Label Content = "{x:Static CorLib.Environment.OSVersion}"/>
    <Label Content = "{x:Static CorLib.Environment.ProcessorCount}"/>
```

```

<!-- The Type markup extension is a XAML version of
the C# typeof operator -->
<Label Content="{x:Type Button}" />
<Label Content="{x:Type CorLib:Boolean}" />

<!-- Fill a ListBox with an array of strings! -->
<ListBox Width="200" Height="50">
  <ListBox.ItemsSource>
    <x:Array Type="CorLib:String">
      <CorLib:String>Sun Kil Moon</CorLib:String>
      <CorLib:String>Red House Painters</CorLib:String>
      <CorLib:String>Besnard Lakes</CorLib:String>
    </x:Array>
  </ListBox.ItemsSource>
</ListBox>
</StackPanel>
</Page>

```

First, notice that the <Page> definition has a new XML namespace declaration, which allows you to gain access to the System namespace of mscorlib.dll. With this XML namespace established, you first make use of the x:Static markup extension and grab values from OSVersion and ProcessorCount of the System.Environment class.

The x:Type markup extension allows you to gain access to the metadata description of the specified item. Here, you are simply assigning the fully qualified names of the WPF Button and System.Boolean types.

The most interesting part of this markup is the ListBox. Here, you are setting the ItemsSource property to an array of strings declared entirely in markup! Notice here how the x:Array markup extension allows you to specify a set of subitems within its scope:

```

<x:Array Type="CorLib:String">
  <CorLib:String>Sun Kil Moon</CorLib:String>
  <CorLib:String>Red House Painters</CorLib:String>
  <CorLib:String>Besnard Lakes</CorLib:String>
</x:Array>

```

■ **Note** The previous XAML example is only used to illustrate a markup extension in action. As you will see in Chapter 27, there are much easier ways to populate ListBox controls!

Figure 26-13 shows the mark up of this <Page> in Kaxaml.

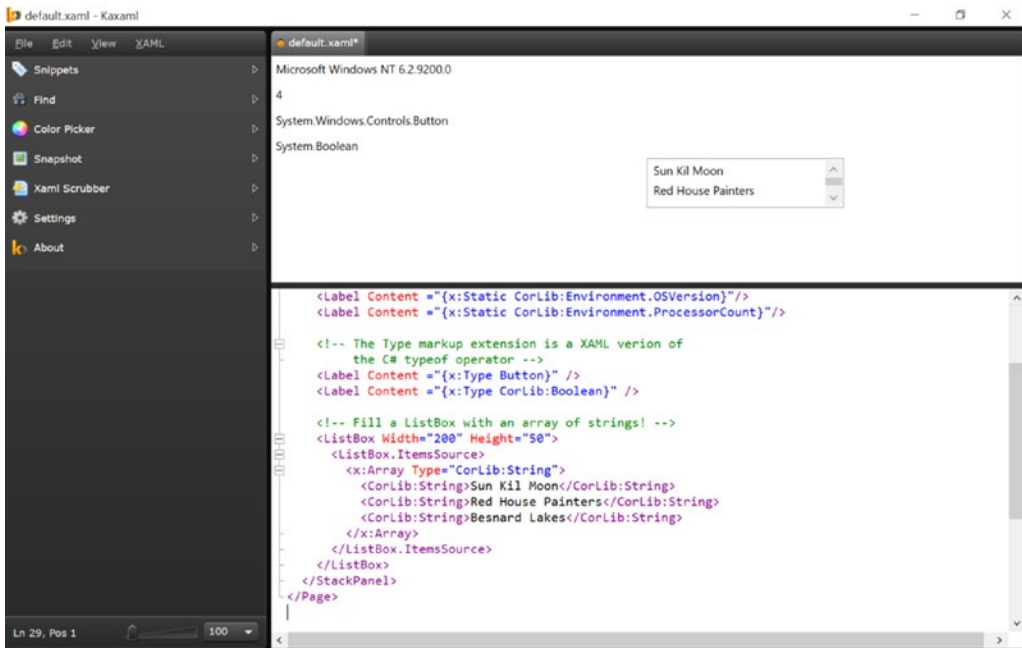

Figure 26-13. Markup extensions allow you to set values via the functionality of a dedicated class

You have now seen numerous examples that showcase each of the core aspects of the XAML syntax. As you might agree, XAML is very interesting in that it allows you to describe a tree of .NET objects in a declarative manner. While this is extremely helpful when configuring graphical user interfaces, do remember that XAML can describe *any* type from *any* assembly, provided it is a nonabstract type containing a default constructor.

Building a WPF Application Using Code-Behind Files

The first two examples of this chapter illustrated the extreme ends of building a WPF application, using all code or using all XAML. The recommended way to build any WPF application, however, is to use the *code file* approach. Under this model, the XAML files of your project contain nothing but the markup that describes the general state of your classes, while the code file contains the implementation details.

Adding a Code File for the MainWindow Class

To illustrate, you will update the WpfAppAllXaml example to use code files. If you are following along, copy this entire folder and give it the name WpfAppCodeFiles. Now, create a new C# code file in this folder named MainWindow.xaml.cs (by convention, the name of a C# code-behind file takes the form *.xaml.cs). Add the following code to this new file:

```

// MainWindow.xaml.cs
using System;
using System.Windows;
using System.Windows.Controls;

```

```

namespace WpfAppAllXaml
{
    public partial class MainWindow : Window
    {
        public MainWindow()
        {
            // Remember! This method is defined
            // within the generated MainWindow.g.cs file.
            InitializeComponent();
        }

        private void btnExitApp_Clicked(object sender, RoutedEventArgs e)
        {
            this.Close();
        }
    }
}

```

Here, you have defined a partial class to contain the event-handling logic that will be merged with the partial class definition of the same type in the *.g.cs file. Given that `InitializeComponent()` is defined within the `MainWindow.g.cs` file, your window's constructor makes a call in order to load and process the embedded BAML resource.

The `MainWindow.xaml` file will also need to be updated; this simply involves gutting all traces of the previous C# code.

```

<Window x:Class="WpfAppAllXaml.MainWindow"
    xmlns="http://schemas.microsoft.com/winfx/2006/xaml/presentation"
    xmlns:x="http://schemas.microsoft.com/winfx/2006/xaml"
    Title="A Window built using Code Files!"
    Height="200" Width="300"
    WindowStartupLocation="CenterScreen">

    <Window.Content>
        <!-- The event handler is now in your code file -->
        <Button x:Name="btnExitApp" Width="133" Height="24"
            Content="Close Window" Click="btnExitApp_Clicked"/>
    </Window.Content>

</Window>

```

Adding a Code File for the MyApp Class

If desired, you could also build a code-behind file for your Application-derived type. Because most of the action takes place in the `MyApp.g.cs` file, the code within `MyApp.xaml.cs` is little more than the following:

```

// MyApp.xaml.cs
using System;
using System.Windows;
using System.Windows.Controls;
namespace WpfAppAllXaml

```

```

{
    public partial class MyApp : Application
    {
        private void AppExit(object sender, ExitEventArgs e)
        {
            MessageBox.Show("App has exited");
        }
    }
}

```

The MyApp.xaml file now looks like so:

```

<Application x:Class="WpfAppAllXaml.MyApp"
    xmlns="http://schemas.microsoft.com/winfx/2006/xaml/presentation"
    xmlns:x="http://schemas.microsoft.com/winfx/2006/xaml"
    StartupUri="MainWindow.xaml"
    Exit="AppExit">
</Application>

```

Processing the Code Files with msbuild.exe

Before you recompile your files using `msbuild.exe`, you need to update your *.csproj file to account for the new C# files to include in the compilation process, via the `<Compile>` elements (shown here in bold):

```

<Project DefaultTargets="Build" xmlns=
    "http://schemas.microsoft.com/developer/msbuild/2003">
    <PropertyGroup>
        <RootNamespace>WpfAppAllXaml</RootNamespace>
        <AssemblyName>WpfAppAllXaml</AssemblyName>
        <OutputType>winexe</OutputType>
    </PropertyGroup>
    <ItemGroup>
        <Reference Include="System" />
        <Reference Include="WindowsBase" />
        <Reference Include="PresentationCore" />
        <Reference Include="PresentationFramework" />
        <Reference Include="System.Xaml" />
    </ItemGroup>
    <ItemGroup>
        <ApplicationDefinition Include="MyApp.xaml" />
        <Compile Include="MainWindow.xaml.cs" />
        <Compile Include="MyApp.xaml.cs" />
        <Page Include="MainWindow.xaml" />
    </ItemGroup>
    <Import Project="$(MSBuildBinPath)\Microsoft.CSharp.targets" />
</Project>

```

Once you pass the build script into `msbuild.exe` via

```
msbuild WpfAppAllXaml.csproj
```

you will find, once again, the same executable assembly as the `WpfAppAllXaml` application (located in the `bin\Debug` folder, remember?). However, as far as development is concerned, you now have a clean partition of presentation (XAML) from programming logic (C#).

Given that this is the preferred method for WPF development, you'll be happy to know that WPF applications created using Visual Studio (or Expression Blend) always make use of the code-behind model just presented.

■ **Source Code** The `WpfAppCodeFiles` project can be found in the Chapter 26 subdirectory.

Building WPF Applications Using Visual Studio

Over the course of this chapter you created examples using no-frills text editors, the command-line compiler, and Kaxaml. The reason for doing so, of course, was to focus on the core syntax of WPF applications without getting distracted by the bells and whistles of a graphical designer. Now that you have seen how to build WPF applications from the ground up, let's examine how Visual Studio can simplify the construction of WPF programs.

■ **Note** Here, I will point out some key features of using Visual Studio to build WPF applications. Forthcoming chapters will illustrate additional aspects of the IDE where necessary.

The WPF Project Templates

The New Project dialog box of Visual Studio defines a set of WPF project workspaces, all of which are contained under the Window node of the Visual C# root. Here, you can choose from a WPF Application, WPF User Control Library, WPF Custom Control Library, and WPF Browser Application (i.e., XBAP). To begin, create a new WPF application named `WpfTesterApp` (see Figure 26-14).

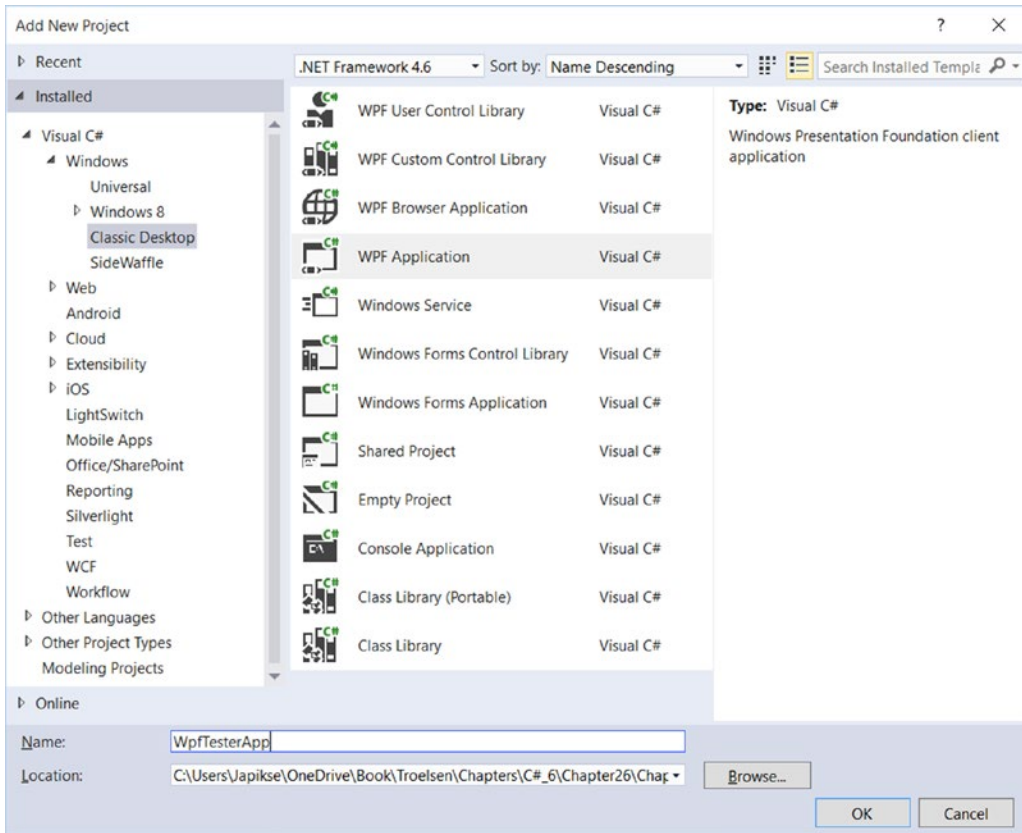

Figure 26-14. The WPF project templates of Visual Studio can be found under the Windows node

Beyond setting references to each of the WPF assemblies (`PresentationCore.dll`, `PresentationFramework.dll`, `System.Xaml.dll`, and `WindowsBase.dll`), you will also be provided with initial `Window` and `Application` derived classes, each represented using a XAML and C# code file. Consider Figure 26-15, which shows the Solution Explorer for this new WPF project.

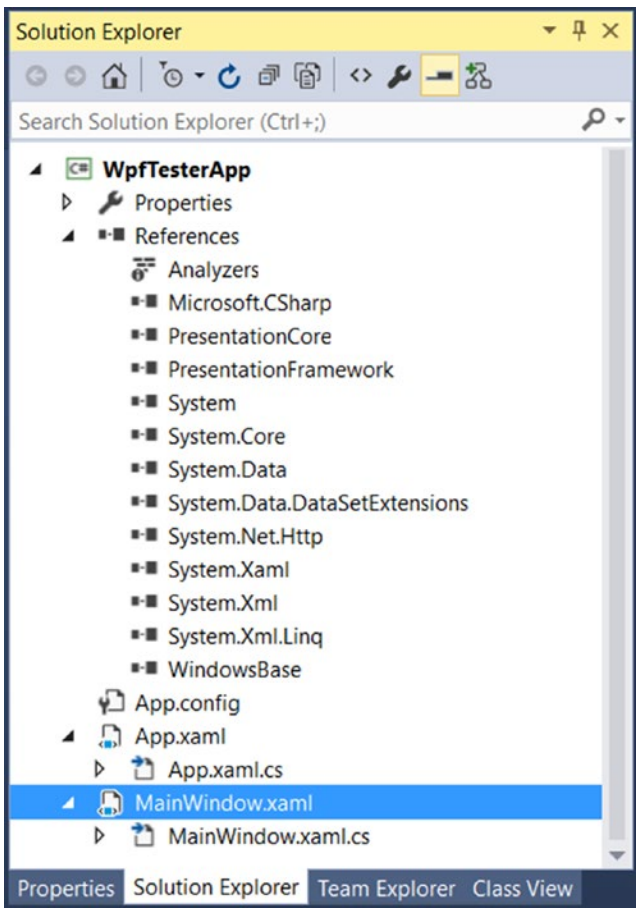

Figure 26-15. The initial files of a WPF application project

The Toolbox and XAML Designer/Editor

Visual Studio provides a toolbox (which you can open via the View menu) that contains numerous WPF controls (see Figure 26-16).

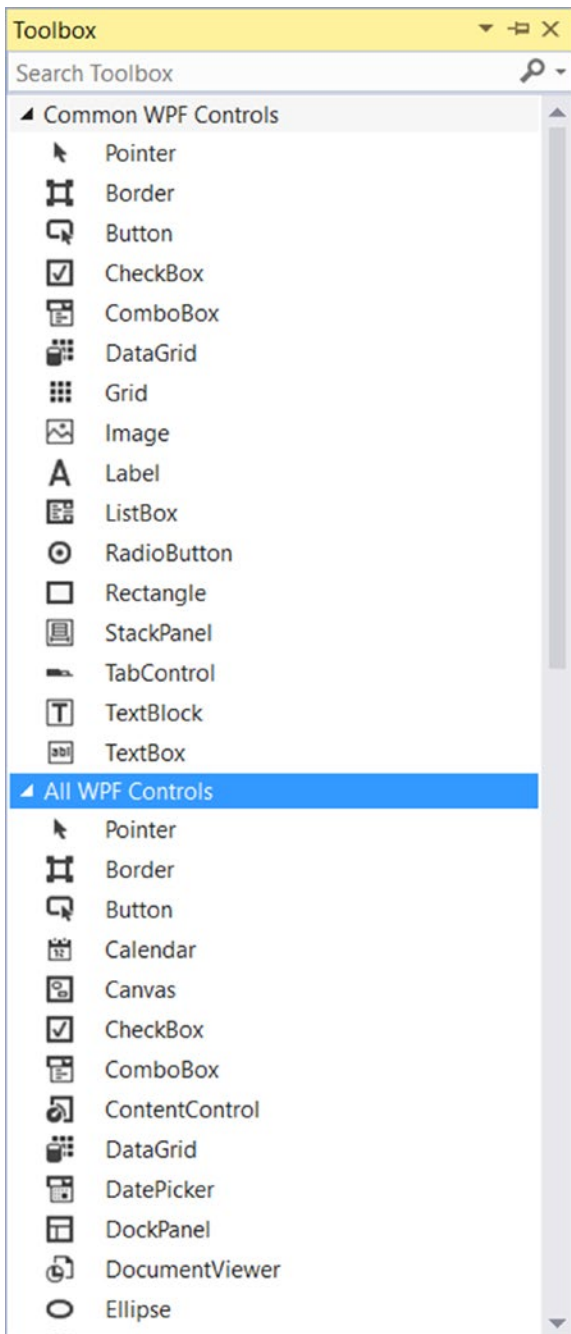

Figure 26-16. The toolbox contains the WPF controls that can be placed on the designer surface

Using a standard mouse drag-and-drop operation, you can place any of these controls onto the Window's designer surface or drag the control into the XAML markup editor at the bottom of the designer. When you do, the initial XAML will be authored on your behalf. Use your mouse to drag a `Button` and `Calendar` control onto the designer surface. After you have done so, notice how you can relocate and resize your controls (and be sure to examine the resulting XAML generated based on your edits).

In addition to building the UI via the mouse and toolbox, you can also manually enter your markup using the integrated XAML editor. As you can see in Figure 26-17, you do get IntelliSense support, which can help simplify the authoring of the markup. For example, try to add the `Background` property to the opening `<Window>` element.

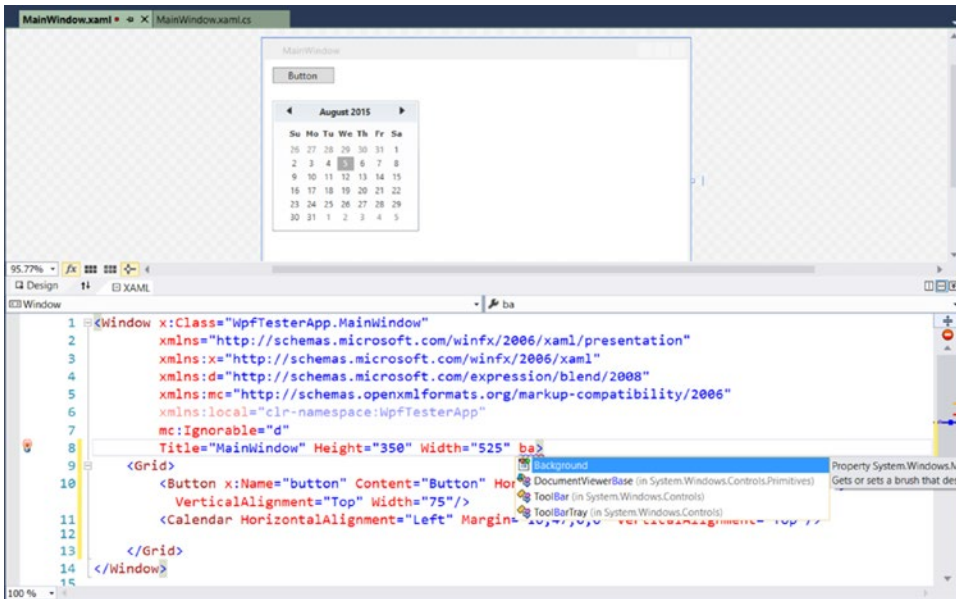

Figure 26-17. The WPF Window designer

Take a few moments to add some property values directly in the XAML editor. Be sure you take the time to become comfortable using this aspect of the WPF designer.

Setting Properties Using the Properties Window

After you have placed some controls onto your designer (or manually defined them in the editor), you can then make use of the Properties window to set property values for the selected control, as well as rig up event handlers for the selected control. By way of a simple test, select your `Button` control on the designer. Now, use the Properties window to change the `Background` color of the `Button` using the integrated brush editor (see Figure 26-18; you will learn more about the Brushes editor in Chapter 28, during your examination of WPF graphics).

■ **Note** The Properties window provides a Search text area mounted on the very top. Type in the name of a property you would like to set to quickly find the item in question.

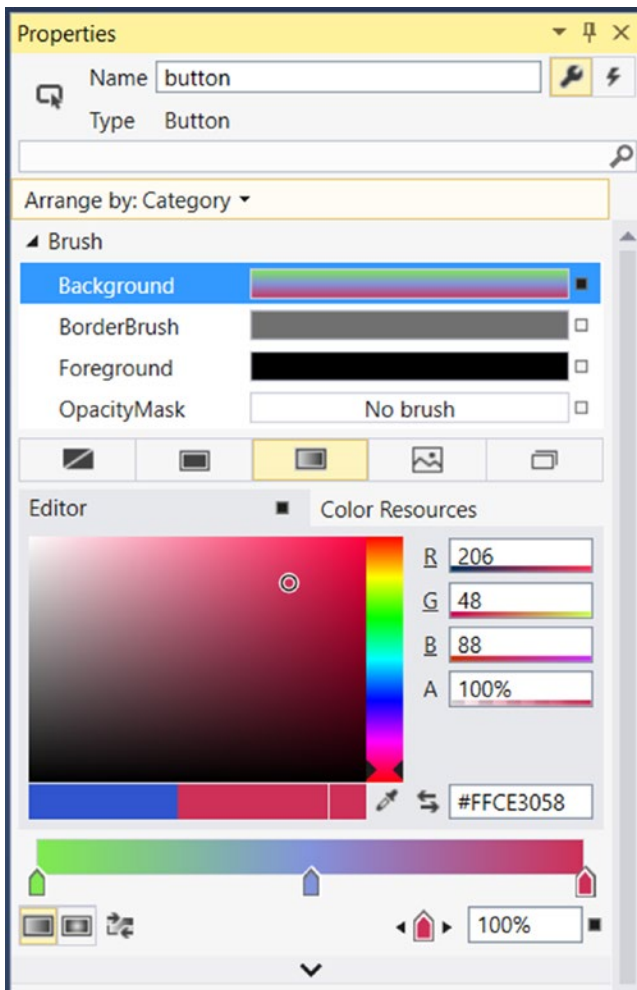

Figure 26-18. The Properties window can be used to configure the UI of a WPF control

After you have finished tinkering with the brush editor, check out the generated markup. It might look something like this:

```
<Button x:Name="button" Content="Button" HorizontalAlignment="Left" Margin="10,10,0,0"
  VerticalAlignment="Top" Width="75">
  <Button.Background>
    <LinearGradientBrush EndPoint="0.5,1" StartPoint="0.5,0">
      <GradientStop Color="#FF80EB4F" Offset="0"/>
      <GradientStop Color="#FFCE3058" Offset="1"/>
      <GradientStop Color="#FF8293DD" Offset="0.5"/>
    </LinearGradientBrush>
  </Button.Background>
</Button>
```

Handling Events Using the Properties Window

If you want to handle events for a given control, you can also make use of the Properties window, but this time you need to click the Events button on the upper right of the Properties window (look for the lightning bolt icon). Ensure that the button is selected on your designer, and locate the `Click` event. Once you do, double-click directly on the `Click` event entry. This will cause Visual Studio to automatically build an event handler that takes the following general form:

```
NameOfControl_NameOfEvent
```

Since you did not rename your button, the Properties window shows it generated an event handler named `Button_Click` (see Figure 26-19).

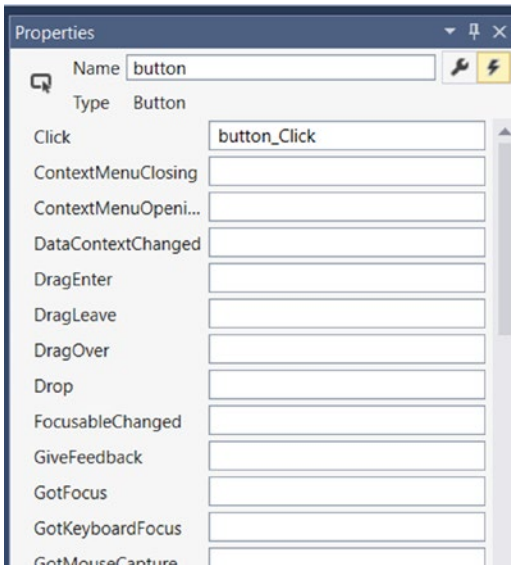

Figure 26-19. Handling events using the Properties window

As well, Visual Studio generated the corresponding C# event handler in your window's code file. Here, you can add any sort of code that must execute when the button is clicked. For a quick test, just enter the following code statement:

```
public partial class MainWindow : Window
{
    public MainWindow()
    {
        InitializeComponent();
    }

    private void Button_Click(object sender, RoutedEventArgs e)
    {
        MessageBox.Show("You clicked the button!");
    }
}
```

Handling Events in the XAML Editor

You can also handle events directly in the XAML editor. By way of an example, place your mouse within the `<Window>` element and type in the `MouseMove` event, followed by the equals sign. Once you do, you will see that Visual Studio displays any compatible handlers in your code file (if they exist), as well as the `Create` method option (see Figure 26-20).

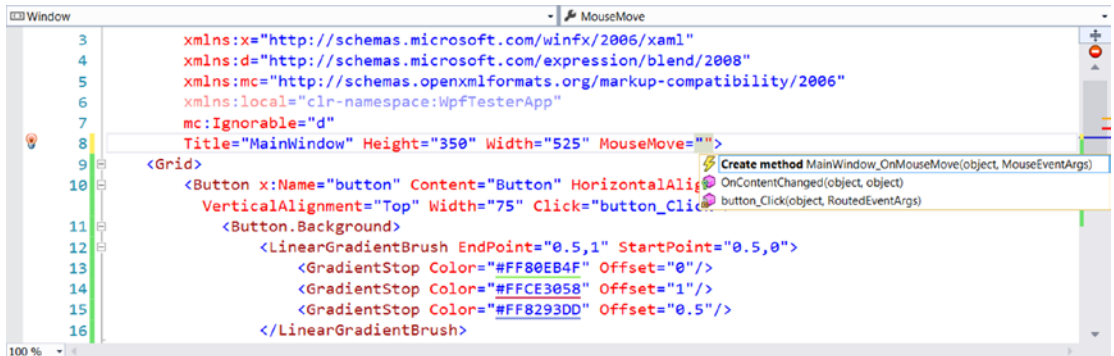

Figure 26-20. Handling events using the XAML editor

Let the IDE create the `MouseMove` event handler, enter the following code, and then run the application to see the end result:

```

private void MainWindow_MouseMove (object sender, MouseEventArgs e)
{
    this.Title = e.GetPosition(this).ToString();
}

```

The Document Outline Window

When you work with any XAML-based project (WPF, Silverlight, Windows Phone/Windows 10 Mobile or a Windows 10 Application), you will certainly make use of a healthy amount of markup to represent your UIs. When you begin to work with more complex XAML, it can be useful to visualize the markup in order to quickly select an item to edit on the Visual Studio designer.

Currently, your markup is quite tame because you have only defined a few controls within the initial `<Grid>`. Nevertheless, locate the Documents Outline window in your IDE, mounted by default on the lower left of the IDE (if you cannot locate it, simply activate it using the `View Other Windows` menu option). Now, make sure your XAML designer is the active window in the IDE (rather than a C# code file), and you will notice the Document Outline displays the nested elements (see Figure 26-21).

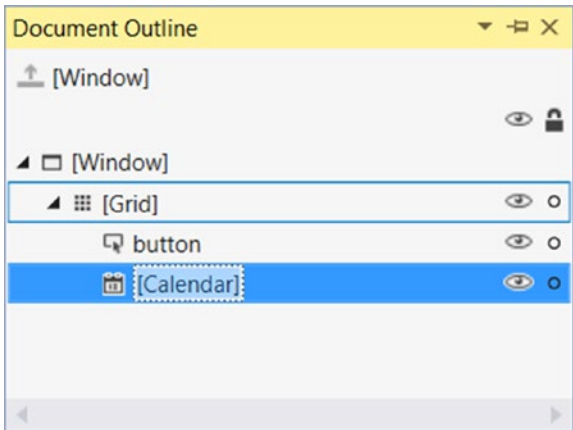

Figure 26-21. Visualizing your XAML via the Document Outline window

This tool also provides a way to temporarily hide a given item (or set of items) on the designer as well as lock items to prevent additional edits from taking place. In the next chapter, you will see how the Document Outline window also provides many other features to group selected items into new layout managers (among other features).

Viewing the Autogenerated Code Files

Before building the last example of this chapter, locate the Solution Explorer window, and click the Show All Files button (seen in Figure 26-22). Notice that the BAML and *.g.cs files are present and accounted for (in the obj\Debug folder). I'm not advising you to add your own code to these autogenerated files, the previous examples of the chapter should have helped clarify exactly how your XAML is processed.

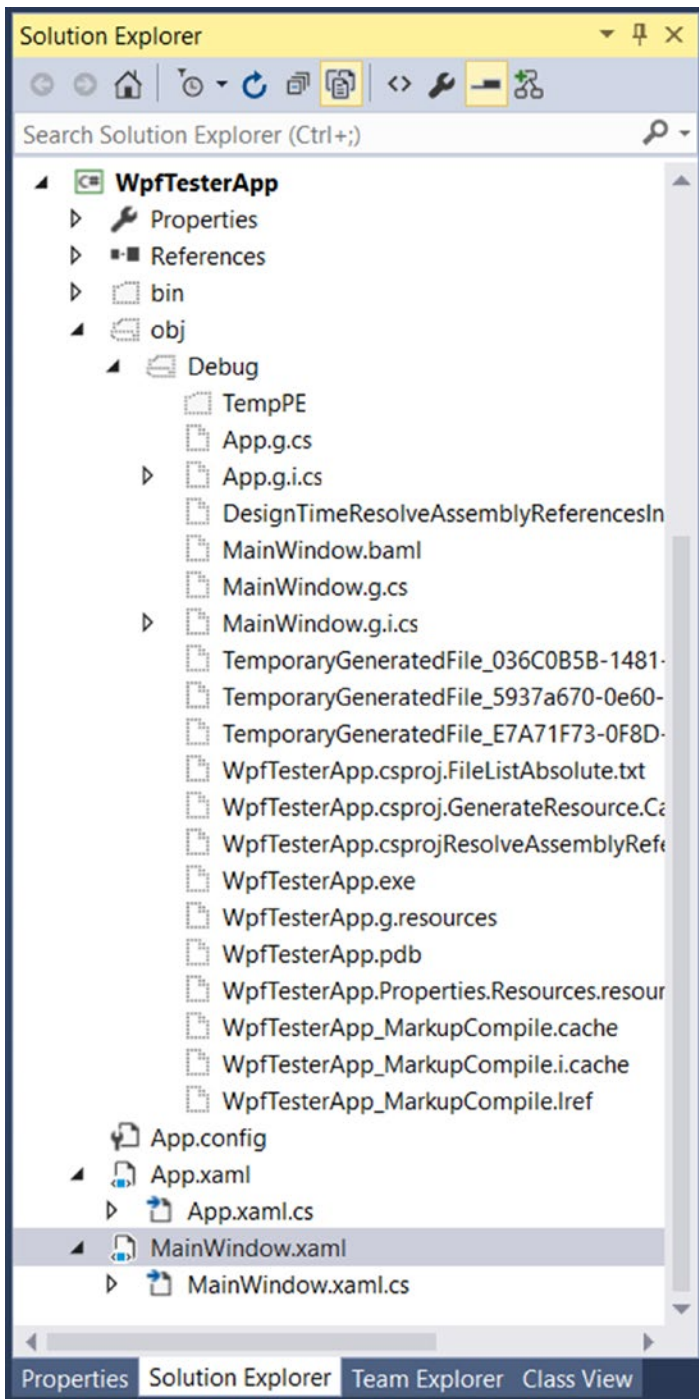

Figure 26-22. Viewing the output files of a WPF project using Solution Explorer

Building a Custom XAML Editor with Visual Studio

Now that you have seen the basic tools used within Visual Studio to design a WPF window, the final example of this chapter will walk you through building an application that will allow you to manipulate XAML at runtime. Close down your current project, and create a fresh WPF application named MyXamlPad. This project (when finished) will function similar to Kaxaml without the bells and whistles. Specifically, this application will allow you to type in any well-formed markup, and click a button to dynamically render the XAML into a new Window object.

Designing the GUI of Your Window

The WPF API supports the ability to load, parse, and save XAML descriptions programmatically. Doing so can be quite useful in a variety of situations. For example, assume you have five different XAML files that describe the look and feel of a Window type. As long as the names of each control (and any necessary event handlers) are identical within each file, it is possible to dynamically apply “skins” to the window (perhaps based on a startup argument passed into the application).

Interacting with XAML at runtime revolves around the `XamlReader` and `XamlWriter` types, both of which are defined within the `System.Windows.Markup` namespace. To illustrate how to programmatically hydrate a Window object from an external `*.xaml` file, you will build an application that mimics the basic functionality of the Kaxaml.

■ **Note** The `XamlReader` and `XamlWriter` classes provide basic functionality to manipulate XAML at runtime. If you ever have a need to gain full control over the XAML object model, you will want to explore the `System.Xaml.dll` assembly.

While your application will certainly not be as feature-rich as Kaxaml, it will provide the ability to enter valid XAML markup, view the results, and save the XAML to an external file. To begin, update the initial XAML definition of your `<Window>` as shown next (I suggest manually typing the XAML at this point; however, use the IDE to generate event handlers as shown previously).

■ **Note** The next chapter will dive into the details of working with controls and panels, so don't fret over the details of the control declarations.

```
<Window x:Class="MyXamlPad.MainWindow"
  xmlns="http://schemas.microsoft.com/winfx/2006/xaml/presentation"
  xmlns:x="http://schemas.microsoft.com/winfx/2006/xaml"
  Title="My Custom XAML Editor"
  Height="338" Width="1041"
  Loaded="Window_Loaded" Closed="Window_Closed"
  WindowStartupLocation="CenterScreen">

  <!-- You will use a DockPanel, not a Grid -->
  <DockPanel LastChildFill="True" >
```



```

<!-- This button will launch a window with defined XAML -->
<Button DockPanel.Dock="Top" Name = "btnViewXaml" Width="100" Height="40"
        Content ="View Xaml" Click="btnViewXaml_Click" />

<!-- This will be the area to type within -->
<TextBox AcceptsReturn ="True" Name ="txtXamlData"
        FontSize ="14" Background="Black" Foreground="Yellow"
        BorderBrush ="Blue" VerticalScrollBarVisibility="Auto"
        AcceptsTab="True"/>
</DockPanel>
</Window>

```

First, notice that you have replaced the initial `<Grid>` with a `<DockPanel>` layout manager that contains a `Button` (named `btnViewXaml`) and a `TextBox` (named `txtXamlData`), and that the `Click` event of the `Button` type has been handled.

Also notice that the `Loaded` and `Closed` events of the `Window` itself have been handled within the opening `<Window>` element (again, use the IDE to generate the event handlers as described earlier in this section of the chapter). If you have used the designer to handle your events, you should find the following code in your `MainWindow.xaml.cs` file:

```

public partial class MainWindow : Window
{
    public MainWindow()
    {
        InitializeComponent();
    }

    private void btnViewXaml_Click(object sender, RoutedEventArgs e)
    {
    }

    private void Window_Closed(object sender, EventArgs e)
    {
    }

    private void Window_Loaded(object sender, RoutedEventArgs e)
    {
    }
}

```

Before continuing, be sure to import the following namespaces into your `MainWindow.xaml.cs` file:

```

using System.IO;
using System.Windows.Markup;

```

Implementing the Loaded Event

The Loaded event of your main window is in charge of determining whether there is currently a file named `YourXaml.xaml` in the folder containing the application. If this file does exist, you will read in the data and place it into the `TextBox` on the main window. If not, you will fill the `TextBox` with an initial default XAML description of an empty window (this description is the exact same markup as an initial window definition, except that you are using a `<StackPanel>` rather than a `<Grid>`).

■ **Note** The string you are building to represent the initial markup to display in your editor is a bit cumbersome to type, given the escape characters required for the embedded quotations, so type carefully.

```
private void Window_Loaded(object sender, RoutedEventArgs e)
{
    // When the main window of the app loads,
    // place some basic XAML text into the text block.
    if (File.Exists("YourXaml.xaml"))
    {
        txtXamlData.Text = File.ReadAllText("YourXaml.xaml");
    }
    else
    {
        txtXamlData.Text =
            "<Window xmlns=\"http://schemas.microsoft.com/winfx/2006/xaml/presentation\" \n"
            + "xmlns:x=\"http://schemas.microsoft.com/winfx/2006/xaml\" \n"
            + "Height =\"400\" Width =\"500\" WindowStartupLocation=\"CenterScreen\">\n"
            + "<StackPanel>\n"
            + "</StackPanel>\n"
            + "</Window>";
    }
}
```

Using this approach, your application will be able to load the XAML entered in a previous session or supply a default block of markup if necessary. At this point, you should be able to run your program and find the display shown in Figure 26-23 within the `TextBox` type.

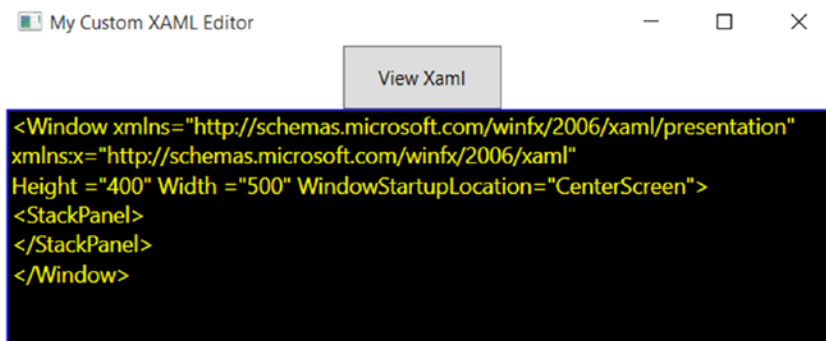

Figure 26-23. The first run of `MyXamlPad.exe`

Implementing the Button's Click Event

When you click the Button, you will first save the current data in the TextBox into the `YourXaml.xaml` file. At this point, you will read in the persisted data via `File.Open()` to obtain a `FileStream`. This is necessary, as the `XamlReader.Load()` method requires a `Stream`-derived type (rather than a simple `System.String`) to represent the XAML to be parsed.

After you have loaded the XAML description of the `<Window>` you would like to construct, create an instance of `System.Windows.Window` based on the in-memory XAML and display the Window as a modal dialog, like so:

```
private void btnViewXaml_Click(object sender, RoutedEventArgs e)
{
    // Write out the data in the text block to a local *.xaml file.
    File.WriteAllText("YourXaml.xaml", txtXamlData.Text);
    // This is the window that will be dynamically XAML-ed.
    Window myWindow = null;
    // Open local *.xaml file.
    try
    {
        using (Stream sr = File.Open("YourXaml.xaml", FileMode.Open))
        {
            // Connect the XAML to the Window object.
            myWindow = (Window)XamlReader.Load(sr);

            // Show window as a dialog and clean up.
            myWindow.ShowDialog();
            myWindow.Close();
            myWindow = null;
        }
    }
    catch (Exception ex)
    {
        MessageBox.Show(ex.Message);
    }
}
```

Note that you are wrapping much of your logic within a try/catch block. In this way, if the `YourXaml.xaml` file contains ill-formed markup, you can see the error of your ways within the resulting message box. For example, run your program, and purposely misspell `<StackPanel>` by adding an extra letter P in the opening element or whatnot. If you click the button, you will see an error similar to Figure 26-24.

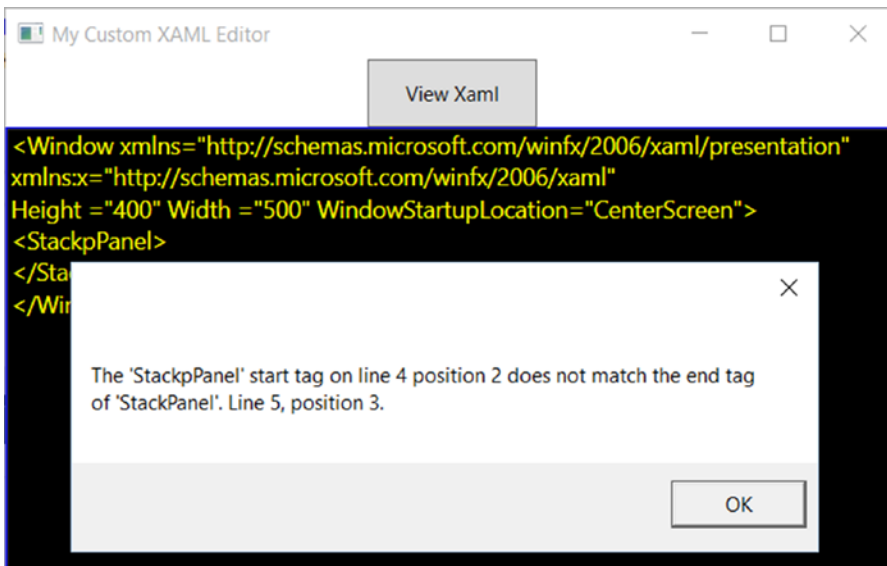

Figure 26-24. Catching markup errors

Implementing the Closed Event

Finally, the Closed event of your Window type will ensure that the latest and greatest data in the TextBox is persisted to the YourXaml.xaml file.

```
private void Window_Closed(object sender, EventArgs e)
{
    // Write out the data in the text block to a local *.xaml file.
    File.WriteAllText("YourXaml.xaml", txtXamlData.Text);
    Application.Current.Shutdown();
}
```

Testing Your Application

Now fire up your program and enter some XAML into your text area. Do be aware that (like Kaxaml) this program does not allow you to specify any code generation-centric XAML attributes (such as Class or any event handlers). As a first test, enter the following XAML within your <StackPanel> scope:

```
<Button Height = "100" Width = "100" Content = "Click Me!">
  <Button.Background>
    <LinearGradientBrush StartPoint = "0,0" EndPoint = "1,1">
      <GradientStop Color = "Blue" Offset = "0" />
      <GradientStop Color = "Yellow" Offset = "0.25" />
      <GradientStop Color = "Green" Offset = "0.75" />
      <GradientStop Color = "Pink" Offset = "0.50" />
    </LinearGradientBrush>
  </Button.Background>
</Button>
```

When you click the button, you will see a window appear that renders your XAML definitions (or possibly you'll see a parsing error in the message box—watch your typing!). Figure 26-25 shows possible output.

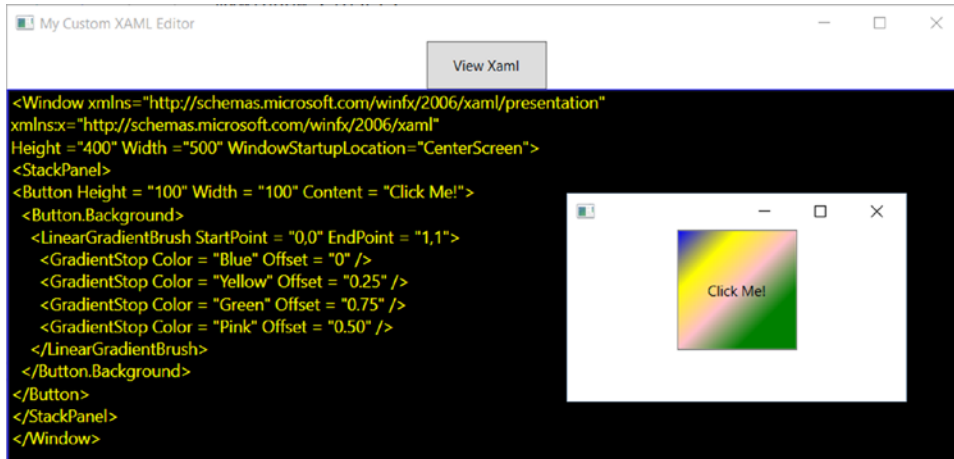

Figure 26-25. *MyXamlPad.exe* in action

Now, enter the following XAML markup directly after the current `<Button>` definition:

```
<Label Content = "Interesting...">
  <Label.Triggers>
    <EventTrigger RoutedEvent = "Label.Loaded">
      <EventTrigger.Actions>
        <BeginStoryboard>
          <Storyboard TargetProperty = "FontSize">
            <DoubleAnimation From = "12" To = "100" Duration = "0:0:4"
              RepeatBehavior = "Forever"/>
          </Storyboard>
        </BeginStoryboard>
      </EventTrigger.Actions>
    </EventTrigger>
  </Label.Triggers>
</Label>
```

This markup is a great example of how powerful XAML really is. When you test this markup, you'll notice you have created a simple animation sequence. Animation services (as well as graphical renderings) will be examined in detail in upcoming chapters; however, feel free to tweak the XAML and see the end result.

Exploring the WPF Documentation

To close this chapter, I want to point out that the .NET 4.6 Framework SDK documentation provides an entire section devoted to the topic of WPF. As you explore this API and read over the remaining WPF-centric chapters, you will do yourself a great service if you consult the help system early and often. Here, you will find a huge amount of sample XAML plus detailed tutorials on a wide variety of topics ranging from 3D graphics programming to complex data binding operations.

The WPF documentation is located under the .NET Framework 4.6 ► .NET Framework Development Guide ► Developing Client Applications path located at [https://msdn.microsoft.com/en-us/library/vstudio/54xbah2z\(v=vs.110\)](https://msdn.microsoft.com/en-us/library/vstudio/54xbah2z(v=vs.110)).

As you dig around this part of the help system, you will run into numerous XAML examples you can copy directly to your clipboard and paste into your custom XAML editor. However, you will need to make sure the root element is changed from <Page> to <Window> (if the samples use the <Page> element) before testing (your application was not programmed to display Page objects, only full Window objects). Before moving on to the next chapter, take time to dig into topics that interest you and test additional markup in your custom tool.

■ **Source Code** The MyXamlPad project can be found in the Chapter 26 subdirectory.

Summary

Windows Presentation Foundation (WPF) is a user interface toolkit introduced since the release of .NET 3.0. The major goal of WPF is to integrate and unify a number of previously unrelated desktop technologies (2D graphics, 3D graphics, window and control development, etc.) into a single, unified programming model. Beyond this point, WPF programs typically make use of Extendable Application Markup Language (XAML), which allows you to declare the look and feel of your WPF elements via markup.

Recall that XAML allows you to describe trees of .NET objects using a declarative syntax. During this chapter's investigation of XAML, you were exposed to several new bits of syntax, including property-element syntax and attached properties, as well as the role of type converters and XAML markup extensions.

While XAML is a key aspect for any production-level WPF application, your first example of this chapter illustrated how you can build a WPF program using nothing but C# code. Next, you discovered how to build a WPF program using nothing but XAML (this is not recommended; however, it was a useful learning exercise!). Finally, you learned about the use of code-behind files, which allow you to partition look-and-feel from functionality.

The final example of this chapter gave you a chance to build a WPF application that allowed you to programmatically interact with XAML definitions using the `XamlReader` and `XamlWriter` classes. Along the way, you took a tour of the core WPF designers of Visual Studio. You will learn much more about the WPF designers in upcoming chapters.

CHAPTER 27



Programming with WPF Controls

Chapter 26 provided a foundation for the WPF programming model, including an examination of the `Window` and `Application` classes, the grammar of XAML, and the use of code files. Chapter 26 also introduced you to the process of building WPF applications using the designers of Visual Studio. In this chapter, you will dig into the construction of more sophisticated graphical user interfaces using several new controls and layout managers, learning about additional features of the WPF designers of Visual Studio along the way.

This chapter will also examine some important related WPF control topics such as the data-binding programming model and the use of control commands. You will also learn how to use the Ink and Documents APIs, which allow you to capture stylus (or mouse) input and build rich text documents using the XML Paper Specification, respectively.

■ **Note** Previous editions of this text made use of a product named Microsoft Expression Blend to facilitate building GUIs using the WPF API. However, the latest version of Visual Studio provides sufficient functionality to build WPF UIs for the topics examined in this text. If you would like to learn the details of working with Expression Blend, check out Andrew's book *Pro Expression Blend 4* (2011, Apress).

A Survey of the Core WPF Controls

Unless you are new to the concept of building graphical user interfaces (which is fine), the general purpose of the major WPF controls should not raise too many issues. Regardless of which GUI toolkit you might have used in the past (e.g., VB 6.0, MFC, Java AWT/Swing, Windows Forms, Mac OS X [Cocoa], or GTK+/GTK# [among others]), the core WPF controls listed in Table 27-1 are likely to look familiar.

Table 27-1. *The Core WPF Controls*

| WPF Control Category | Example Members | Meaning in Life |
|-------------------------------|--|---|
| Core user input controls | Button, RadioButton, ComboBox, CheckBox, Calendar, DatePicker, Expander, DataGrid, ListBox, ListView, ToggleButton, TreeView, ContextMenu, ScrollBar, Slider, TabControl, TextBlock, TextBox, RepeatButton, RichTextBox, Label | WPF provides an entire family of controls you can use to build the crux of a user interface. |
| Window and control adornments | Menu,ToolBar,StatusBar,ToolTip,ProgressBar | You use these UI elements to decorate the frame of a Window object with input devices (such as the Menu) and user informational elements (e.g., StatusBar and ToolTip). |
| Media controls | Image,MediaElement,SoundPlayerAction | These controls provide support for audio/video playback and image display. |
| Layout controls | Border,Canvas,DockPanel,Grid,GridView,GridSplitter,GroupBox,Panel,TabControl,StackPanel,Viewbox,WrapPanel | WPF provides numerous controls that allow you to group and organize other controls for the purpose of layout management. |

The WPF Ink Controls

In addition to the common WPF controls listed in Table 27-1, WPF defines additional controls for working with the digital Ink API. This aspect of WPF development is useful during Tablet PC development because it lets you capture input from the stylus. However, this is not to say a standard desktop application cannot leverage the Ink API because the same controls can capture input using the mouse.

The `System.Windows.Ink` namespace of `PresentationCore.dll` contains various Ink API support types (e.g., `Stroke` and `StrokeCollection`); however, a majority of the Ink API controls (e.g., `InkCanvas` and `InkPresenter`) are packaged up with the common WPF controls under the `System.Windows.Controls` namespace in the `PresentationFramework.dll` assembly. You'll work with the Ink API later in this chapter.

The WPF Document Controls

WPF also provides controls for advanced document processing, allowing you to build applications that incorporate Adobe PDF-style functionality. Using the types within the `System.Windows.Documents` namespace (also in the `PresentationFramework.dll` assembly), you can create print-ready documents that support zooming, searching, user annotations (sticky notes), and other rich text services.

Under the covers, however, the document controls do not use Adobe PDF APIs; rather, they use the XML Paper Specification (XPS) API. To the end user, there will really appear to be no difference because PDF documents and XPS documents have an almost identical look-and-feel. In fact, you can find many free utilities that allow you to convert between the two file formats on the fly. You'll work with some aspects of the document controls in an upcoming example.

WPF Common Dialog Boxes

WPF also provides you with a few common dialog boxes such as `OpenFileDialog` and `SaveFileDialog`. These dialog boxes are defined within the `Microsoft.Win32` namespace of the `PresentationFramework.dll` assembly. Working with either of these dialog boxes is a matter of creating an object and invoking the `ShowDialog()` method, like so:

```
using Microsoft.Win32;

namespace WpfControls
{
    public partial class MainWindow : Window
    {
        public MainWindow()
        {
            InitializeComponent();
        }

        private void btnShowDlg_Click(object sender, RoutedEventArgs e)
        {
            // Show a file save dialog.
            SaveFileDialog saveDlg = new SaveFileDialog();
            saveDlg.ShowDialog();
        }
    }
}
```

As you would hope, these classes support various members that allow you to establish file filters and directory paths, and gain access to user-selected files. You will put these file dialogs to use in later examples; you will also learn how to build custom dialog boxes to gather user input.

The Details Are in the Documentation

Despite what you might be thinking, the intent of this chapter is *not* to walk through each and every member of each and every WPF control. Rather, you will receive an overview of the various controls with an emphasis on the underlying programming model and key services common to most WPF controls.

To round out your understanding of the particular functionality of a given control, be sure to consult the .NET Framework 4.6 SDK documentation—specifically, the Control Library section of the help system, which you can find at [https://msdn.microsoft.com/en-us/library/bb613551\(v=vs.100\).aspx](https://msdn.microsoft.com/en-us/library/bb613551(v=vs.100).aspx).

■ **Note** At the time of this writing, the WPF documentation is somewhat lacking, as you will discover when you navigate to the aforementioned link. The current documentation is for .NET 4.5. The good news is that there are very few changes in WPF between .NET 4.5 and .NET 4.6 (mostly performance improvements).

Here you will find full details of each control, various code samples (in XAML, as well as C#), and information regarding a control's inheritance chain, implemented interfaces, and applied attributes. Make sure you take time to look up the controls examined in this chapter for complete details.

A Brief Review of the Visual Studio WPF Designer

A majority of these standard WPF controls have been packaged up in the `System.Windows.Controls` namespace of the `PresentationFramework.dll` assembly. When you build a WPF application using Visual Studio, you will find most of these common controls contained in the toolbox, provided you have a WPF designer open as the active window (see Figure 27-1).

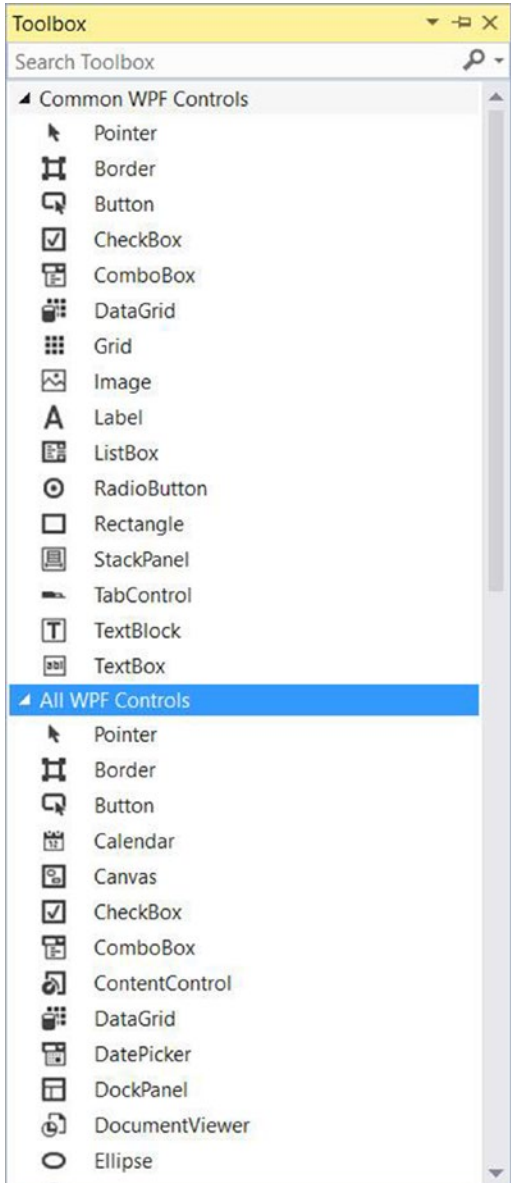

Figure 27-1. The Visual Studio toolbox exposes the many commonly used WPF controls

Similar to other UI frameworks created with Visual Studio, you can drag these controls onto the WPF window designer and configure them using the Properties window (which you learned about in Chapter 26). While Visual Studio will generate a good amount of the XAML on your behalf, it is not uncommon to edit the markup yourself manually. Let's review the basics.

Working with WPF Controls Using Visual Studio

You might recall from Chapter 26 that when you place a WPF control onto the Visual Studio designer, you want to set the `x:Name` property through the Properties window because this allows you to access the object in your related C# code file. You might also recall that you can use the Events tab of the Properties window to generate event handlers for a selected control. Thus, you could use Visual Studio to generate the following markup for a simple `Button` control:

```
<Button x:Name="btnMyButton" Content="Click Me!" Height="23" Width="140"
        Click="btnMyButton_Click" />
```

Here, you set the `Content` property of the `Button` to a simple string with the value "Click Me!". However, thanks to the WPF control content model, you could fashion a `Button` that contains the following complex content:

```
<Button x:Name="btnMyButton" Height="121" Width="156" Click="btnMyButton_Click">
  <Button.Content>
    <StackPanel Height="95" Width="128" Orientation="Vertical">
      <Ellipse Fill="Red" Width="52" Height="45" Margin="5"/>
      <Label Width="59" FontSize="20" Content="Click!" Height="36" />
    </StackPanel>
  </Button.Content>
</Button>
```

You might also recall that the immediate child element of a `ContentControl`-derived class is the implied content; therefore, you do not need to define a `<Button.Content>` scope explicitly when specifying complex content. You could simply author the following:

```
<Button x:Name="btnMyButton" Height="121" Width="156" Click="btnMyButton_Click">
  <StackPanel Height="95" Width="128" Orientation="Vertical">
    <Ellipse Fill="Red" Width="52" Height="45" Margin="5"/>
    <Label Width="59" FontSize="20" Content="Click!" Height="36" />
  </StackPanel>
</Button>
```

In either case, you set the button's `Content` property to a `<StackPanel>` of related items. You can also author this sort of complex content using the Visual Studio designer. After you define the layout manager for a content control, you can select it on the designer to serve as a drop target for the internal controls. At this point, you can edit each using the Properties window. If you were to use the Properties window to handle the `Click` event for the `Button` control (as seen in the previous XAML declarations), the IDE would generate an empty event handler, to which you could add your own custom code, like so:

```
private void btnMyButton_Click(object sender, RoutedEventArgs e)
{
    MessageBox.Show("You clicked the button!");
}
```

Working with the Document Outline Editor

You should also be aware that the Document Outline window of Visual Studio (which you can open using the View ► Other Windows menu) is useful when designing a WPF control that has complex content. Notice in Figure 27-2 how the logical tree of XAML is displayed for the Window you are building. If you click any of these nodes, it is automatically selected in the designer for editing.

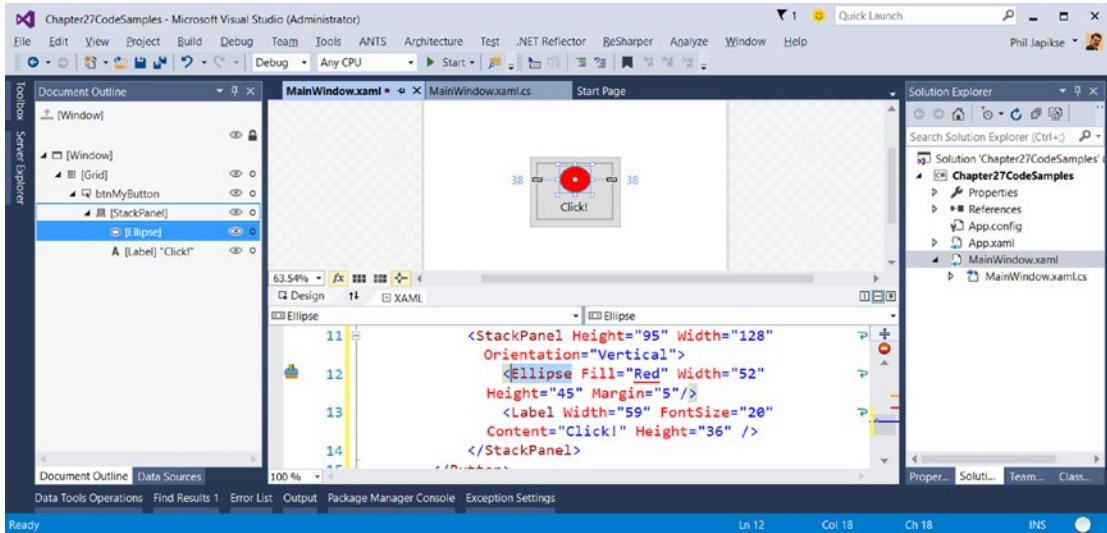

Figure 27-2. The Visual Studio Document Outline window can help you navigate complex content

With the current edition of Visual Studio, the Document Outline editor has a few additional features that you might find useful. To the right of any node you will find an icon that looks similar to an eyeball. When you toggle this button, you can opt to hide or show an item on the designer, which can be helpful when you want to focus in on a particular segment to edit (note that this will *not* hide the item at runtime; this is only hides items on the designer surface).

Right next to the “eyeball icon” is a second toggle that allows you to “lock” an item on the designer. As you might guess, this can be very helpful when you want to make sure you (or your coworkers) do not accidentally change the XAML for a given item. In effect, locking an item makes it read-only at design time (however, you can obviously change the object’s state at runtime).

Controlling Content Layout Using Panels

A WPF application invariably contains a good number of UI elements (e.g., user input controls, graphical content, menu systems, and status bars) that need to be well organized within various windows. After you place the UI elements, you need to make sure they behave as intended when the end user resizes the window or possibly a portion of the window (as in the case of a splitter window). To ensure your WPF controls retain their position within the hosting window, you can take advantage of a good number of *panel types* (also known as *layout managers*).

By default, a new WPF Window created with Visual Studio will use a layout manager of type `<Grid>` (more details in just a bit). However, for now, assume a Window with no declared layout manager, like so:

```
<Window x:Class="MyWPFApp.MainWindow"
  xmlns="http://schemas.microsoft.com/winfx/2006/xaml/presentation"
  xmlns:x="http://schemas.microsoft.com/winfx/2006/xaml"
  ...
  Title="Fun with Panels!" Height="285" Width="325">

</Window>
```

When you declare a control directly inside a window that doesn't use panels, the control is positioned dead-center in the container. Consider the following simple window declaration, which contains a single Button control. Regardless of how you resize the window, the UI widget is always equidistant from all four sides of the client area. The Button's size is determined by the assigned Height and Width properties of the Button.

```
<!-- This button is in the center of the window at all times -->
<Window x:Class="MyWPFApp.MainWindow"
  xmlns="http://schemas.microsoft.com/winfx/2006/xaml/presentation"
  xmlns:x="http://schemas.microsoft.com/winfx/2006/xaml"
  ...
  Title="Fun with Panels!" Height="285" Width="325">

  <Button x:Name="btnOK" Height = "100"
    Width="80" Content="OK"/>

</Window>
```

You might also recall that if you attempt to place multiple elements directly within the scope of a `<Window>`, you will receive markup and compile-time errors. The reason for these errors is that a window (or any descendant of `ContentControl` for that matter) can assign only a single object to its `Content` property. Therefore, the following XAML yields markup and compile time errors:

```
<!-- Error! Content property is implicitly set more than once! -->
<Window x:Class="MyWPFApp.MainWindow"
  xmlns="http://schemas.microsoft.com/winfx/2006/xaml/presentation"
  xmlns:x="http://schemas.microsoft.com/winfx/2006/xaml"
  ...
  Title="Fun with Panels!" Height="285" Width="325">

  <!-- Error! Two direct child elements of the <Window>! -->
  <Label x:Name="lblInstructions" Width="328" Height="27"
    FontSize="15" Content="Enter Information"/>
  <Button x:Name="btnOK" Height = "100" Width="80" Content="OK"/>

</Window>
```

Obviously, a window that can only contain a single control is of little use. When a window needs to contain multiple elements, those elements must be arranged within any number of panels. The panel will contain all of the UI elements that represent the window, after which the panel itself is used as the single object assigned to the `Content` property.

The `System.Windows.Controls` namespace provides numerous panels, each of which controls how subelements are maintained. You can use panels to establish how the controls behave if the end user resizes the window, if the controls remain exactly where they were placed at design time, if the controls reflow horizontally from left-to-right or vertically from top-to-bottom, and so forth.

You can also intermix panel controls within other panels (e.g., a `DockPanel` that contains a `StackPanel` of other items) to provide a great deal of flexibility and control. Table 27-2 documents the role of some commonly used WPF panel controls.

Table 27-2. Core WPF Panel Controls

| Panel Control | Meaning in Life |
|---------------|--|
| Canvas | Provides a classic mode of content placement. Items stay exactly where you put them at design time. |
| DockPanel | Locks content to a specified side of the panel (Top, Bottom, Left, or Right). |
| Grid | Arranges content within a series of cells, maintained within a tabular grid. |
| StackPanel | Stacks content in a vertical or horizontal manner, as dictated by the <code>Orientation</code> property. |
| WrapPanel | Positions content from left-to-right, breaking the content to the next line at the edge of the containing box. Subsequent ordering happens sequentially from top-to-bottom or from right-to-left, depending on the value of the <code>Orientation</code> property. |

In the next few sections, you will learn how to use these commonly used panel types by copying some predefined XAML data into the `MyXamlPad.exe` application you created in Chapter 26 (you could also load this data into `kaxaml.exe`, if you so choose). You can find all these loose XAML files contained inside the `PanelMarkup` subfolder of your Chapter 27 code download folder (see Figure 27-3).

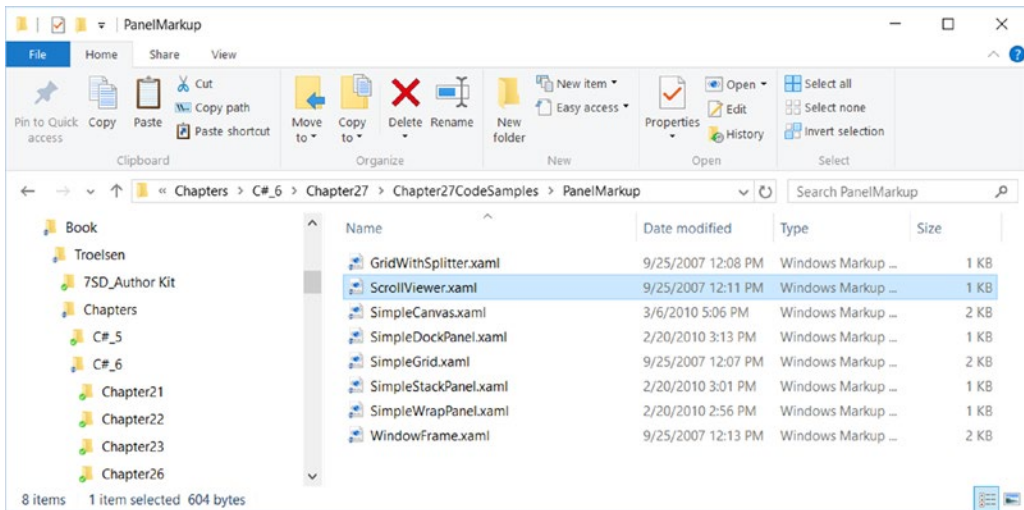

Figure 27-3. You will be loading the supplied XAML data into your `MyXamlPad.exe` application to test various layouts

Positioning Content Within Canvas Panels

You will probably feel most at home with the Canvas panel because it allows for absolute positioning of UI content. If the end user resizes the window to an area that is smaller than the layout maintained by the Canvas panel, the internal content will not be visible until the container is stretched to a size equal to or larger than the Canvas area.

To add content to a Canvas, you begin by defining the required controls within the scope of the opening `<Canvas>` and closing `</Canvas>` tags. Next, specify the upper-left corner for each control; this is where the rendering should begin using the `Canvas.Top` and `Canvas.Left` properties. You can specify the bottom-right area indirectly in each control by setting its `Height` and `Width` properties, or directly by using the `Canvas.Right` and `Canvas.Bottom` properties.

To see Canvas in action, open the provided `SimpleCanvas.xaml` file using a text editor and copy the content into `MyXamlPad.exe` (or `kaxaml.exe`). You should see the following Canvas definition:

```
<Window
  xmlns="http://schemas.microsoft.com/winfx/2006/xaml/presentation"
  xmlns:x="http://schemas.microsoft.com/winfx/2006/xaml"
  ...
  Title="Fun with Panels!" Height="285" Width="325">
  <Canvas Background="LightSteelBlue">
    <Button x:Name="btnOK" Canvas.Left="212" Canvas.Top="203"
      Width="80" Content="OK"/>
    <Label x:Name="lblInstructions" Canvas.Left="17" Canvas.Top="14"
      Width="328" Height="27" FontSize="15"
      Content="Enter Car Information"/>
    <Label x:Name="lblMake" Canvas.Left="17" Canvas.Top="60"
      Content="Make"/>
    <TextBox x:Name="txtMake" Canvas.Left="94" Canvas.Top="60"
      Width="193" Height="25"/>
    <Label x:Name="lblColor" Canvas.Left="17" Canvas.Top="109"
      Content="Color"/>
    <TextBox x:Name="txtColor" Canvas.Left="94" Canvas.Top="107"
      Width="193" Height="25"/>
    <Label x:Name="lblPetName" Canvas.Left="17" Canvas.Top="155"
      Content="Pet Name"/>
    <TextBox x:Name="txtPetName" Canvas.Left="94" Canvas.Top="153"
      Width="193" Height="25"/>
  </Canvas>
</Window>
```

Clicking your View Xaml button causes the window shown in Figure 27-4 to display on the screen.

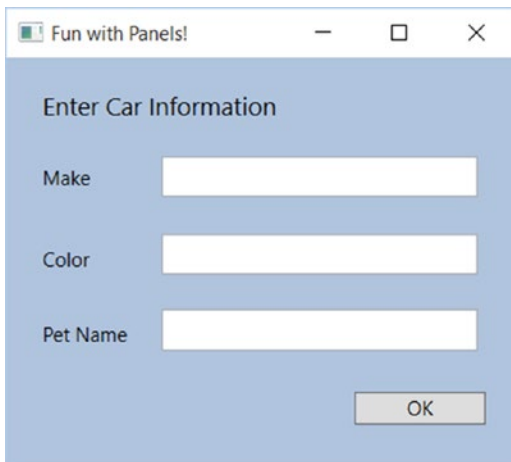

Figure 27-4. The Canvas layout manager allows for absolute positioning of content

Note that the order you declare content within a Canvas is not used to calculate placement; instead, placement is based on the control's size and the `Canvas.Top`, `Canvas.Bottom`, `Canvas.Left`, and `Canvas.Right` properties.

■ **Note** If subelements within a Canvas do not define a specific location using attached property syntax (e.g., `Canvas.Left` and `Canvas.Top`), they automatically attach to the extreme upper-left corner of Canvas.

Using the Canvas type might seem like the preferred way to arrange content (because it feels so familiar), but this approach does suffer from some limitations. First, items within a Canvas do not dynamically resize themselves when applying styles or templates (e.g., their font sizes are unaffected). Second, the Canvas will not attempt to keep elements visible when the end user resizes the window to a smaller surface.

Perhaps the best use of the Canvas type is for positioning *graphical content*. For example, if you were building a custom image using XAML, you certainly would want the lines, shapes, and text to remain in the same location, rather than see them dynamically repositioned as the user resizes the window! You'll revisit Canvas in Chapter 28 when you examine WPF's graphical rendering services.

Positioning Content Within WrapPanel Panels

A `WrapPanel` allows you to define content that will flow across the panel as the window is resized. When positioning elements in a `WrapPanel`, you do not specify top, bottom, left, and right docking values as you typically do with Canvas. However, each subelement is free to define a `Height` and `Width` value (among other property values) to control its overall size in the container.

Because content within a `WrapPanel` does not dock to a given side of the panel, the order in which you declare the elements is important (content is rendered from the first element to the last). If you were to load the XAML data found within the `SimpleWrapPanel.xaml` file, you would find it contains the following markup (enclosed within a `<Window>` definition):

```
<WrapPanel Background="LightSteelBlue">
  <Label x:Name="lblInstruction" Width="328"
    Height="27" FontSize="15" Content="Enter Car Information"/>
```



```

<Label x:Name="lblMake" Content="Make"/>
<TextBox x:Name="txtMake" Width="193" Height="25"/>
<Label x:Name="lblColor" Content="Color"/>
<TextBox x:Name="txtColor" Width="193" Height="25"/>
<Label x:Name="lblPetName" Content="Pet Name"/>
<TextBox x:Name="txtPetName" Width="193" Height="25"/>
<Button x:Name="btnOK" Width="80" Content="OK"/>
</WrapPanel>

```

When you load this markup, the content looks out of sorts as you resize the width because it flows from left-to-right across the window (see Figure 27-5).

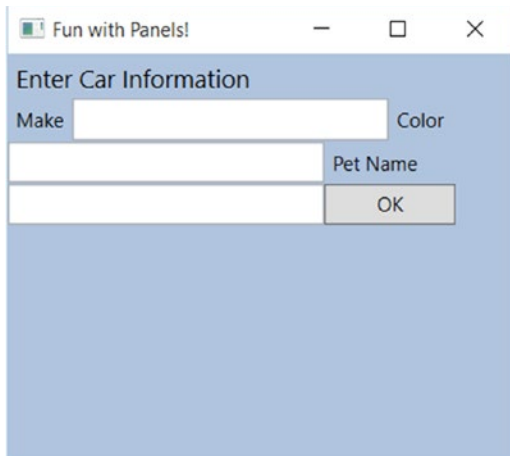
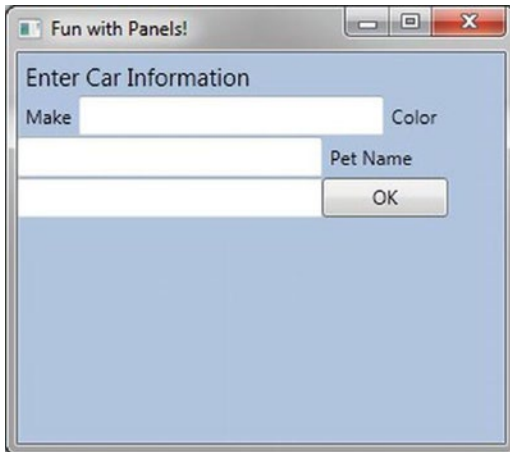

Figure 27-5. Content in a `WrapPanel` behaves much like a traditional HTML page

By default, content within a `WrapPanel` flows from left-to-right. However, if you change the value of the `Orientation` property to `Vertical`, you can have content wrap in a top-to-bottom manner.

```

<WrapPanel Background="LightSteelBlue" Orientation = "Vertical">

```

You can declare a `WrapPanel` (as well as some other panel types) by specifying `ItemWidth` and `ItemHeight` values, which control the default size of each item. If a subelement does provide its own `Height` and/or `Width` value, it will be positioned relative to the size established by the panel. Consider the following markup:

```
<WrapPanel Background="LightSteelBlue" Orientation ="Horizontal" ItemWidth ="200" ItemHeight ="30">
  <Label x:Name="lblInstruction"
        FontSize="15" Content="Enter Car Information"/>
  <Label x:Name="lblMake" Content="Make"/>
  <TextBox x:Name="txtMake"/>
  <Label x:Name="lblColor" Content="Color"/>
  <TextBox x:Name="txtColor"/>
  <Label x:Name="lblPetName" Content="Pet Name"/>
  <TextBox x:Name="txtPetName"/>
  <Button x:Name="btnOK" Width ="80" Content="OK"/>
</WrapPanel>
```

The rendered code looks like Figure 27-6 (notice the size and position of the `Button` control, which has a specified unique `Width` value).

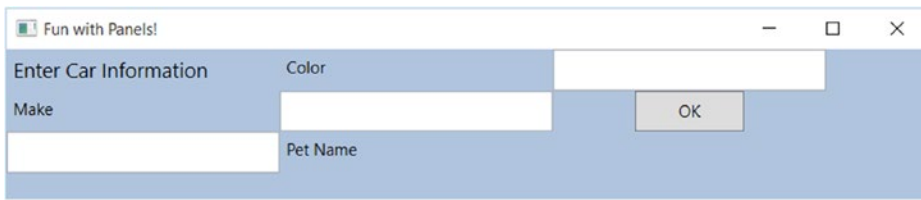

Figure 27-6. A `WrapPanel` can establish the width and height of a given item

As you might agree after looking at Figure 27-6, a `WrapPanel` is not typically the best choice for arranging content directly in a window because its elements can become scrambled as the user resizes the window. In most cases, a `WrapPanel` will be a subelement to another panel type, allowing a small area of the window to wrap its content when resized (e.g., a `ToolBar` control).

Positioning Content Within `StackPanel` Panels

Like a `WrapPanel`, a `StackPanel` control arranges content into a single line that can be oriented horizontally or vertically (the default), based on the value assigned to the `Orientation` property. The difference, however, is that the `StackPanel` will *not* attempt to wrap the content as the user resizes the window. Rather, the items in the `StackPanel` will simply stretch (based on their orientation) to accommodate the size of the `StackPanel` itself. For example, the `SimpleStackPanel.xaml` file contains the following markup, which results in the output shown in Figure 27-7:

```
<StackPanel Background="LightSteelBlue">
  <Label x:Name="lblInstruction"
        FontSize="15" Content="Enter Car Information"/>
  <Label x:Name="lblMake" Content="Make"/>
  <TextBox Name="txtMake"/>
  <Label x:Name="lblColor" Content="Color"/>
  <TextBox x:Name="txtColor"/>
  <Label x:Name="lblPetName" Content="Pet Name"/>
</StackPanel>
```

```

<TextBox x:Name="txtPetName"/>
<Button x:Name="btnOK" Width="80" Content="OK"/>
</StackPanel>

```

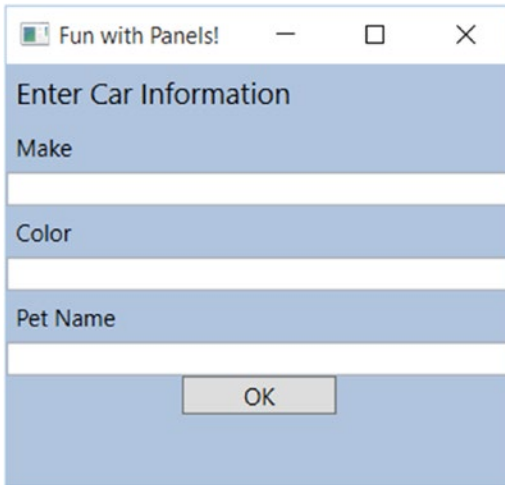

Figure 27-7. Vertical stacking of content

If you assign the `Orientation` property to `Horizontal` as follows, the rendered output will match that shown in Figure 27-8:

```
<StackPanel Background="LightSteelBlue" Orientation="Horizontal">
```



Figure 27-8. Horizontal stacking of content

Again, as is the case with the `WrapPanel`, you will seldom want to use a `StackPanel` to arrange content directly within a window. Instead, you should use `StackPanel` as a subpanel to a master panel.

Positioning Content Within Grid Panels

Of all the panels provided with the WPF APIs, `Grid` is far and away the most flexible. Like an HTML table, the `Grid` can be carved up into a set of cells, each one of which provides content. When defining a `Grid`, you perform three steps.

1. Define and configure each column.
2. Define and configure each row.
3. Assign content to each cell of the grid using attached property syntax.

■ **Note** If you do not define any rows or columns, the <Grid> defaults to a single cell that fills the entire surface of the window. Furthermore, if you do not assign a cell value for a subelement within a <Grid>, it automatically attaches to column 0, row 0.

You achieve the first two steps (defining the columns and rows) by using the <Grid.ColumnDefinitions> and <Grid.RowDefinitions> elements, which contain a collection of <ColumnDefinition> and <RowDefinition> elements, respectively. Each cell within a grid is indeed a true .NET object, so you can configure the look-and-feel and behavior of each cell as you see fit.

Here is a <Grid> definition (that you can find in the SimpleGrid.xaml file) that arranges your UI content as shown in Figure 27-9:

```
<Grid ShowGridLines ="True" Background ="LightSteelBlue">
  <!-- Define the rows/columns -->
  <Grid.ColumnDefinitions>
    <ColumnDefinition/>
    <ColumnDefinition/>
  </Grid.ColumnDefinitions>
  <Grid.RowDefinitions>
    <RowDefinition/>
    <RowDefinition/>
  </Grid.RowDefinitions>

  <!-- Now add the elements to the grid's cells -->
  <Label x:Name="lblInstruction" Grid.Column ="0" Grid.Row ="0"
    FontSize="15" Content="Enter Car Information"/>
  <Button x:Name="btnOK" Height ="30" Grid.Column ="0"
    Grid.Row ="0" Content="OK"/>
  <Label x:Name="lblMake" Grid.Column ="1"
    Grid.Row ="0" Content="Make"/>
  <TextBox x:Name="txtMake" Grid.Column ="1"
    Grid.Row ="0" Width="193" Height="25"/>
  <Label x:Name="lblColor" Grid.Column ="0"
    Grid.Row ="1" Content="Color"/>
  <TextBox x:Name="txtColor" Width="193" Height="25"
    Grid.Column ="0" Grid.Row ="1" />

  <!-- Just to keep things interesting, add some color to the pet name cell -->
  <Rectangle Fill ="LightGreen" Grid.Column ="1" Grid.Row ="1" />
  <Label x:Name="lblPetName" Grid.Column ="1" Grid.Row ="1" Content="Pet Name"/>
  <TextBox x:Name="txtPetName" Grid.Column ="1" Grid.Row ="1"
    Width="193" Height="25"/>
</Grid>
```

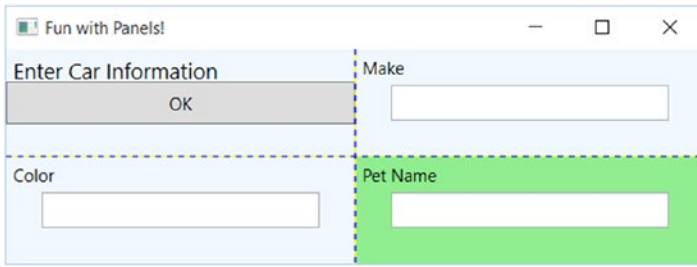

Figure 27-9. *The Grid panel in action*

Notice that each element (including a light green `Rectangle` element thrown in for good measure) connects itself to a cell in the grid using the `Grid.Row` and `Grid.Column` attached properties. By default, the ordering of cells in a grid begins at the upper left, which you specify using `Grid.Column="0" Grid.Row="0"`. Given that your grid defines a total of four cells, you can identify the bottom-right cell using `Grid.Column="1" Grid.Row="1"`.

Grids with GridSplitter Types

Grid objects can also support *splitters*. As you might know, splitters allow the end user to resize rows or columns of a grid type. As this is done, the content within each resizable cell will reshape itself based on how the items have been contained. Adding splitters to a Grid is easy to do; you simply define the `<GridSplitter>` control, using attached property syntax to establish which row or column it affects.

Be aware that you must assign a `Width` or `Height` value (depending on vertical or horizontal splitting) for the splitter to be visible on the screen. Consider the following simple Grid type with a splitter on the first column (`Grid.Column = "0"`). The contents of the provided `GridWithSplitter.xaml` file look like this:

```
<Grid Background="LightSteelBlue">
  <!-- Define columns -->
  <Grid.ColumnDefinitions>
    <ColumnDefinition Width="Auto"/>
    <ColumnDefinition/>
  </Grid.ColumnDefinitions>

  <!-- Add this label to cell 0 -->
  <Label x:Name="lblLeft" Background="GreenYellow"
    Grid.Column="0" Content="Left!"/>

  <!-- Define the splitter -->
  <GridSplitter Grid.Column="0" Width="5"/>

  <!-- Add this label to cell 1 -->
  <Label x:Name="lblRight" Grid.Column="1" Content="Right!"/>
</Grid>
```

First and foremost, notice that the column that will support the splitter has a `Width` property of `Auto`. Next, notice that the `<GridSplitter>` uses attached property syntax to establish which column it is working with. If you were to view this output, you would find a five-pixel splitter that allows you to resize each `Label` (marked with the red arrow). Note that the content fills up the entire cell because you have not specified `Height` or `Width` properties for either `Label` (see Figure 27-10).

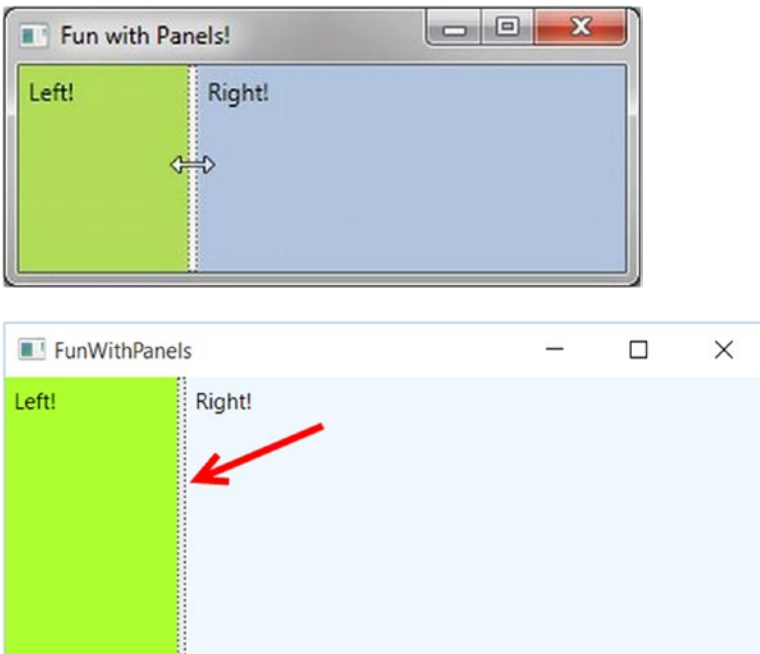

Figure 27-10. Grid types containing splitters

Positioning Content Within DockPanel Panels

DockPanel is typically used as a container that holds any number of additional panels for grouping related content. DockPanels use attached property syntax (as seen with the Canvas or Grid types) to control where each item docks itself within the DockPanel.

The SimpleDockPanel.xaml file defines the following simple DockPanel definition that results in the output shown in Figure 27-11:

```
<DockPanel LastChildFill ="True">
  <!-- Dock items to the panel -->
  <Label x:Name="lblInstruction" DockPanel.Dock ="Top"
    FontSize="15" Content="Enter Car Information"/>
  <Label x:Name="lblMake" DockPanel.Dock ="Left" Content="Make"/>
  <Label x:Name="lblColor" DockPanel.Dock ="Right" Content="Color"/>
  <Label x:Name="lblPetName" DockPanel.Dock ="Bottom" Content="Pet Name"/>
  <Button x:Name="btnOK" Content="OK"/>
</DockPanel>
```

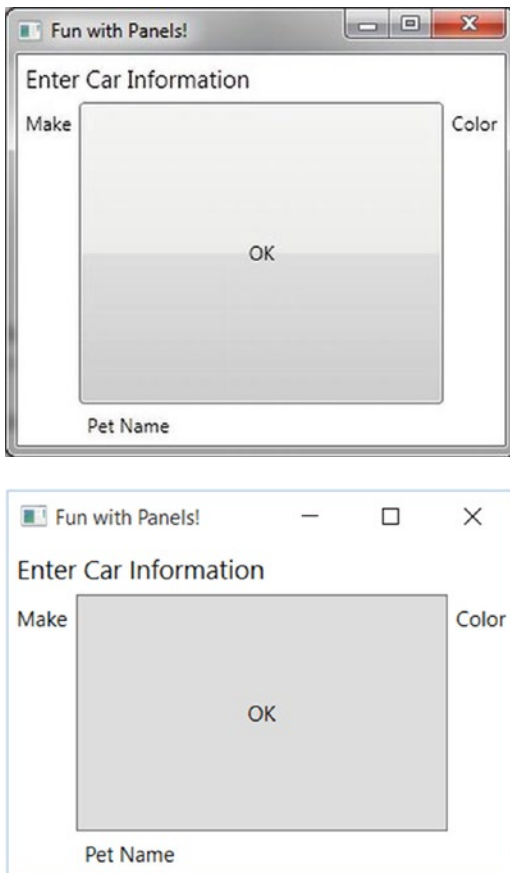

Figure 27-11. A simple *DockPanel*

■ **Note** If you add multiple elements to the same side of a *DockPanel*, they will stack along the specified edge in the order that they are declared.

The benefit of using *DockPanel* types is that, as the user resizes the window, each element remains connected to the specified side of the panel (through *DockPanel.Dock*). Also notice that the opening `<DockPanel>` tag in this example sets the *LastChildFill* attribute to `true`. Given that the *Button* control is indeed the “last child” in the container, it will therefore be stretched within the remaining space.

Enabling Scrolling for Panel Types

It is worth pointing out that WPF supplies a *ScrollViewer* class, which provides automatic scrolling behaviors for data within panel objects. The *ScrollViewer.xaml* file defines the following:

```
<ScrollViewer>
  <StackPanel>
    <Button Content = "First" Background = "Green" Height = "40"/>
    <Button Content = "Second" Background = "Red" Height = "40"/>
  </StackPanel>
</ScrollViewer>
```

```

<Button Content ="Third" Background = "Pink" Height ="40"/>
<Button Content ="Fourth" Background = "Yellow" Height ="40"/>
<Button Content ="Fifth" Background = "Blue" Height ="40"/>
</StackPanel>
</ScrollView>

```

You can see the result of the previous XAML definition in Figure 27-12 (notice the scroll bar on the right since the window isn't sized to show all five buttons).



Figure 27-12. Working with the *ScrollView* type

As you would expect, each panel provides numerous members that allow you to fine-tune content placement. On a related note, many WPF controls support two properties of interest (*Padding* and *Margin*) that allow the control itself to inform the panel how it wishes to be treated. Specifically, the *Padding* property controls how much extra space should surround the interior control, while *Margin* controls the extra space around the exterior of a control.

This wraps up this chapter's look at the major panel types of WPF, as well as the various ways they position their content. Next, you'll learn how to use the Visual Studio designers to create layouts.

Configuring Panels Using the Visual Studio Designers

Now that you have been given a walkthrough of the XAML used to define some common layout managers, you will be happy to know that Visual Studio has some very good design-time support for constructing your layouts. The key to doing so lies with the Document Outline window described earlier in this chapter. To illustrate some of the basics, create a new WPF application project named *VisualLayoutTesterApp*.

Notice how your initial Window makes use of a Grid layout by default:

```

<Window x:Class="VisualLayoutTesterApp.MainWindow"
  xmlns="http://schemas.microsoft.com/winfx/2006/xaml/presentation"
  xmlns:x="http://schemas.microsoft.com/winfx/2006/xaml"
  xmlns:d="http://schemas.microsoft.com/expression/blend/2008"
  xmlns:mc="http://schemas.openxmlformats.org/markup-compatibility/2006"
  xmlns:local="clr-namespace:VisualLayoutTesterApp"
  mc:Ignorable="d"
  Title="MainWindow" Height="350" Width="525">
  <Grid>

  </Grid>
</Window>

```

If you are happy using the Grid layout system, notice in Figure 27-13 that you can easily carve out and resize the grid's cells using the visual layout. To do so, first select the Grid component in your Document Outline window, and then click the grid's border to create new rows and columns.

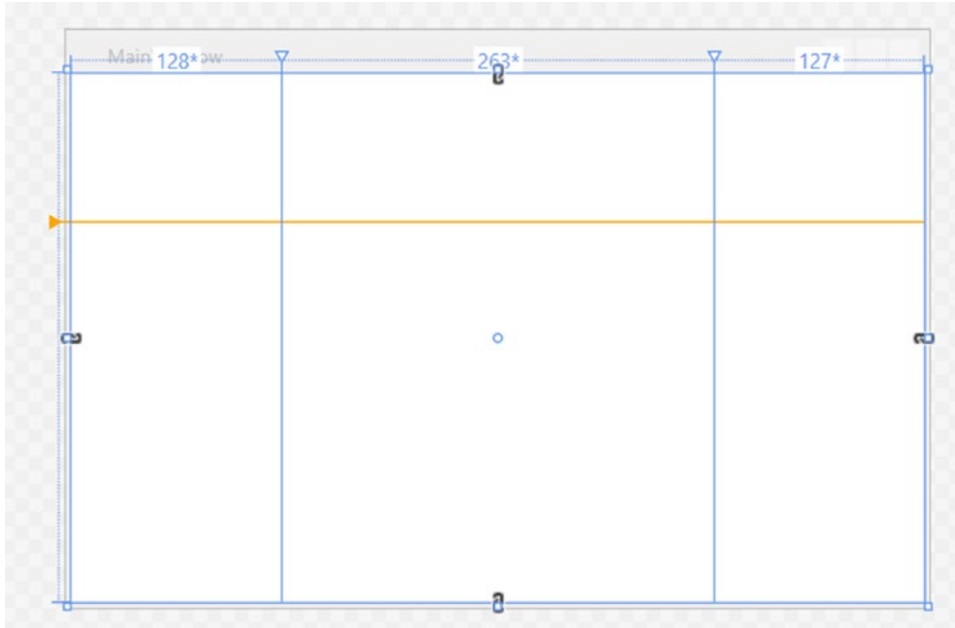

Figure 27-13. The Grid control can be visually cut into cells using the IDE's designer

Now, let's say you have defined a grid with some number of cells. You can then drag and drop controls into a given cell of the layout system, and the IDE will automatically set the `Grid.Row` and `Grid.Column` properties of the control in question. Here is some possible markup generated by the IDE after dragging a Button into a predefined cell:

```
<Button x:Name="button" Content="Button" Grid.Column="1" HorizontalAlignment="Left"
Margin="21,21.4,0,0" Grid.Row="1" VerticalAlignment="Top" Width="75"/>
```

Now, let's say you would rather not use a Grid at all. If you right-click any layout node in the Document Outline window, you will find a menu option that allows you to change the current container into another (see Figure 27-14). Be very aware that when you do so, you will (most likely) radically change the positioning of the controls because the controls will conform to the rules of the new panel type.

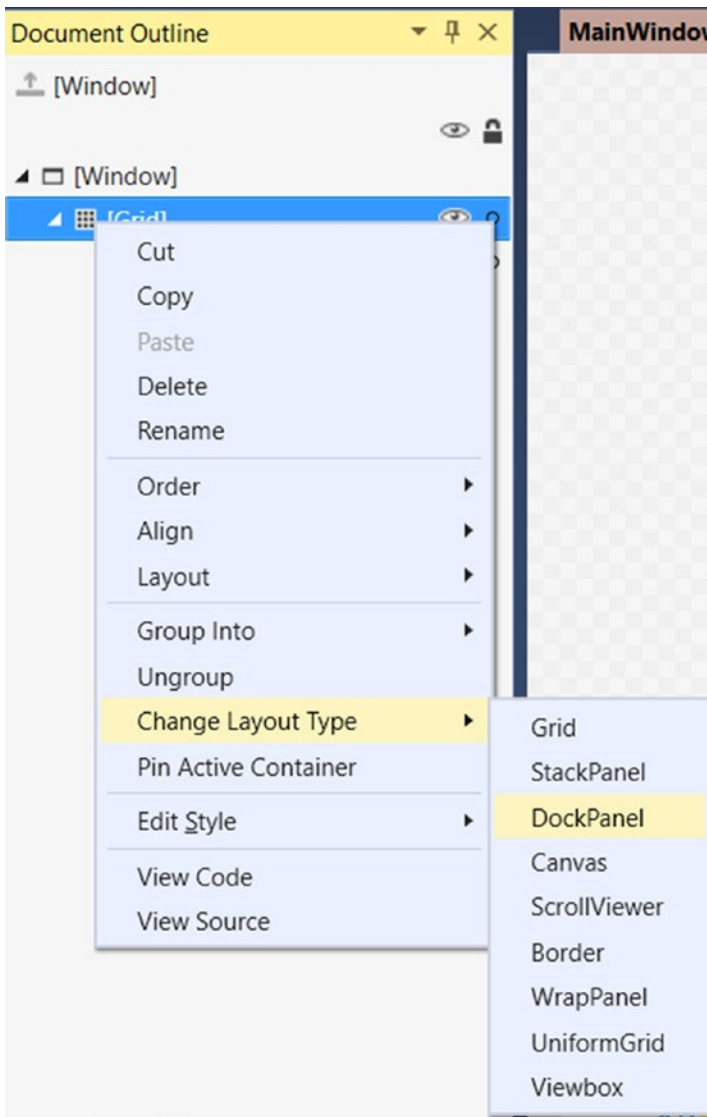

Figure 27-14. The Document Outline window allows you to convert to new panel types

Another handy trick is the ability to select a set of controls on the visual designer and group them into a new, nested layout manager. Assume you have a Canvas that defines a set of random objects (if you want to try, convert the initial Grid to a Canvas using the technique shown in the Figure 27-14). Now, select a set of items on the designer by holding down the CTRL key and clicking each item with the left mouse button. If you then right-click the selection, you can group the selected items into a new subpanel (see Figure 27-15).

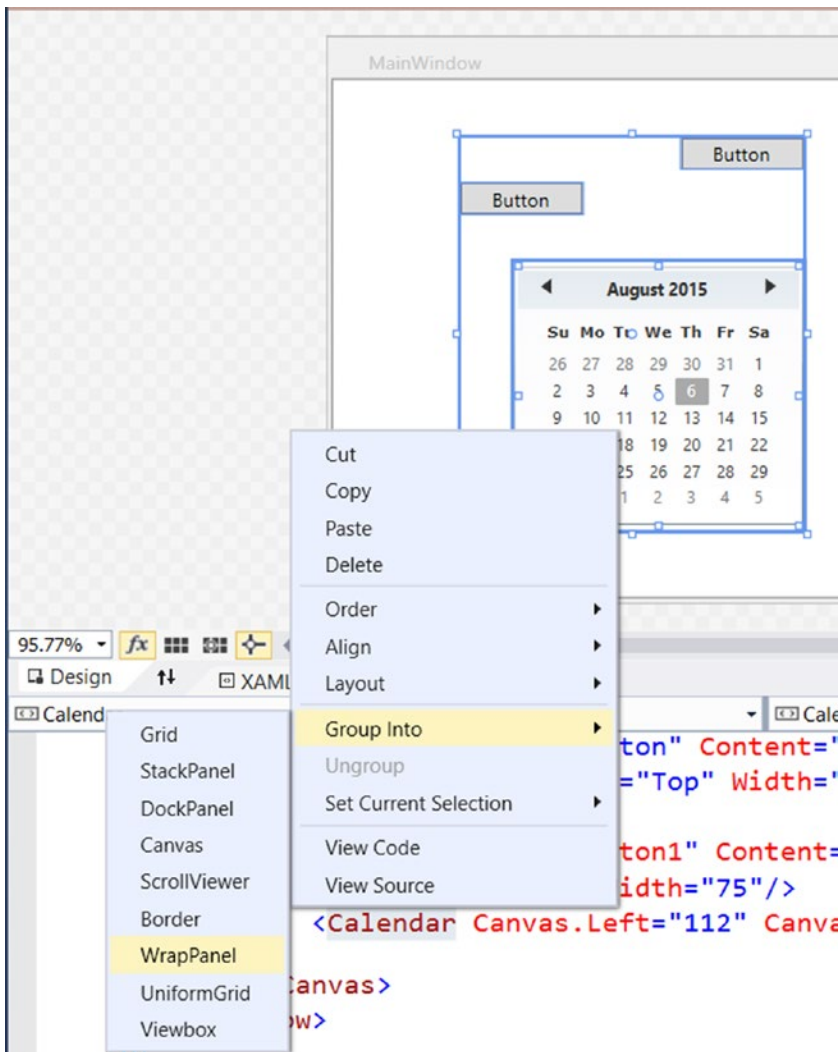

Figure 27-15. Grouping items into a new subpanel

After you have done so, examine the Document Outline window once again to verify the nested layout system. As you build full-featured WPF windows, you will most likely always need to make use of a nested layout system, rather than simply picking a single panel for all of the UI display (in fact, the remaining WPF examples in the text will typically do so). On a final note, the nodes in the Document Outline window are all drag and droppable. For example, if you wanted to move a control currently in the Canvas into the parent panel, you could do so as suggested in Figure 27-16.

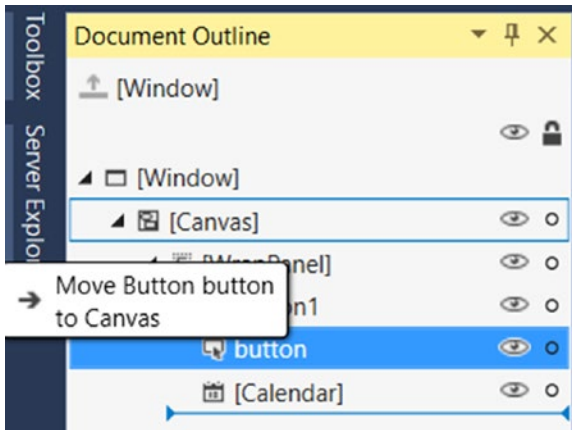

Figure 27-16. Relocating items via the Document Outline window

As you work through the remaining WPF chapters, I'll point out additional layout shortcuts where possible. However, it's definitely worth your time to experiment and test out various features yourself. To keep us moving in the right direction, the next example in the chapter will illustrate how to build a nested layout manager for a custom text processing application (with spell checking!).

Building a Window's Frame Using Nested Panels

As mentioned, a typical WPF window will not use a single panel control, but instead will nest panels within other panels to gain the desired layout system. Begin by creating a new WPF application named MyWordPad.

Your goal is to construct a layout where the main window has a topmost menu system, a toolbar under the menu system, and a status bar mounted on the bottom of the window. The status bar will contain a pane to hold text prompts that are displayed when the user selects a menu item (or toolbar button), while the menu system and toolbar will offer UI triggers to close the application and display spelling suggestions in an Expander widget. Figure 27-17 shows the initial layout you are shooting for; it also displays spelling suggestions for "XAML."

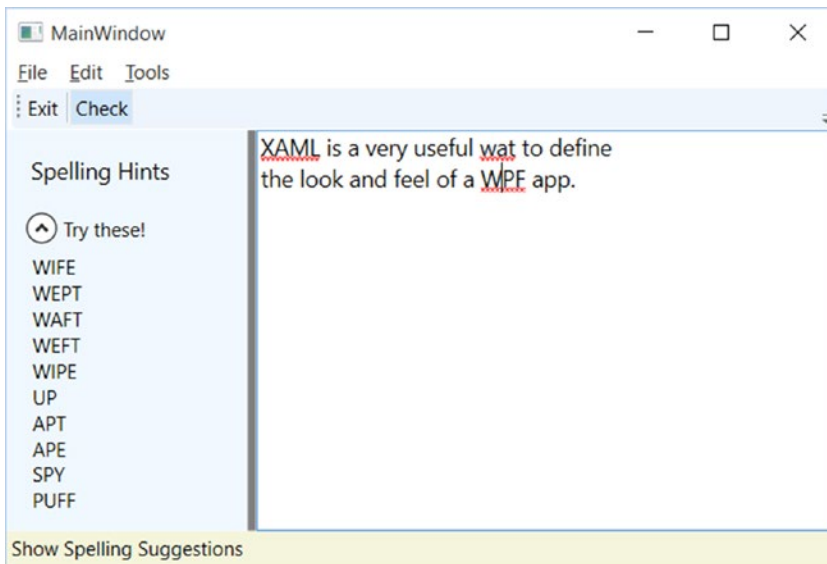

Figure 27-17. Using nested panels to establish a window's UI

Notice that the two toolbar buttons are not supporting an expected image, but a simple text value. This would not be sufficient for a production-level application, but assigning images to toolbar buttons typically involves using embedded resources, a topic that you will examine in Chapter 28 (so text data will do for now). Also note that, as the mouse button is placed over the Check button, the mouse cursor changes and the single pane of the status bar displays a useful UI message.

To begin building this UI, update the initial XAML definition for your Window type so it uses a `<DockPanel>` child element, rather than the default `<Grid>`, as follows:

```
<Window x:Class="MyWordPad.MainWindow"
  xmlns="http://schemas.microsoft.com/winfx/2006/xaml/presentation"
  xmlns:x="http://schemas.microsoft.com/winfx/2006/xaml"
  xmlns:d="http://schemas.microsoft.com/expression/blend/2008"
  xmlns:mc="http://schemas.openxmlformats.org/markup-compatibility/2006"
  xmlns:local="clr-namespace:MyWordPad"
  mc:Ignorable="d"
  Title="My Spell Checker" Height="350" Width="525">

  <!-- This panel establishes the content for the window -->
  <DockPanel>
  </DockPanel>

</Window>
```

Building the Menu System

Menu systems in WPF are represented by the `Menu` class, which maintains a collection of `MenuItem` objects. When building a menu system in XAML, you can have each `MenuItem` handle various events. The most notable of these events is `Click`, which occurs when the end user selects a subitem. In this example, you begin by building the two topmost menu items (File and Tools; you will build the Edit menu later in this example), which expose Exit and Spelling Hints subitems, respectively.

In addition to handling the `Click` event for each subitem, you also need to handle the `MouseEnter` and `MouseExit` events, which you will use to set the status bar text in a later step. Add the following markup within your `<DockPanel>` scope (feel free to use Properties window of Visual Studio to handle each event; see Chapter 26 for a walkthrough on how to do so):

```
<!-- Dock menu system on the top -->
<Menu DockPanel.Dock = "Top"
    HorizontalAlignment="Left" Background="White" BorderBrush = "Black">
  <MenuItem Header="_ File">
    <Separator/>
    <MenuItem Header = "_Exit" MouseEnter = "MouseEnterExitArea"
        MouseLeave = "MouseLeaveArea" Click = "FileExit_Click"/>
  </MenuItem>
  <MenuItem Header="_ Tools">
    <MenuItem Header = "_Spelling Hints"
        MouseEnter = "MouseEnterToolsHintsArea"
        MouseLeave = "MouseLeaveArea" Click = "ToolsSpellingHints_Click"/>
  </MenuItem>
</Menu>
```

Notice that you dock the menu system to the top of the `DockPanel`. Also, you use the `<Separator>` element to insert a thin horizontal line in the menu system, directly before the Exit option. Also notice that the Header values for each `MenuItem` contain an embedded underscore token (e.g., `_Exit`). You use this token to establish which letter will be underlined when the end user presses the Alt key (for keyboard shortcuts). This is a change from the `&` character used in Windows Forms since XAML is based on XML, and the `&` character has meaning in XML.

So far you've implemented the complete the menu system definition; next, you need to implement the various event handlers. First, you have the File Exit handler, `FileExit_Click()`, which simply closes the window, which in turn terminates the application because this is your topmost window. The `MouseEnter` and `MouseExit` event handlers for each subitem will eventually update your status bar; however, for now, you will simply provide shells. Finally, the `ToolsSpellingHints_Click()` handler for the Tools Spelling Hints menu item will also remain a shell for the time being. Here are the current updates to your code-behind file:

```
public partial class MainWindow : Window
{
    public MainWindow()
    {
        InitializeComponent();
    }

    protected void FileExit_Click(object sender, RoutedEventArgs args)
    {
        // Close this window.
        this.Close();
    }
}
```

```

protected void ToolsSpellingHints_Click(object sender, RoutedEventArgs args)
{
}
protected void MouseEnterExitArea(object sender, RoutedEventArgs args)
{
}
protected void MouseEnterToolsHintsArea(object sender, RoutedEventArgs args)
{
}
protected void MouseLeaveArea(object sender, RoutedEventArgs args)
{
}
}

```

Building Menus Visually

While it is always good to know how to manually define items in XAML, it can be a tad on the tedious side. Visual Studio supports visual design support for menu systems, toolbars, status bars, and many other UI controls. By way of a quick example, assume you had a fresh Menu control on a new Window (you might want to insert a test Window via the Project ► Add Window menu option and follow along). Now, if you right-click the Menu control, you will notice an Add MenuItem option (see Figure 27-18).

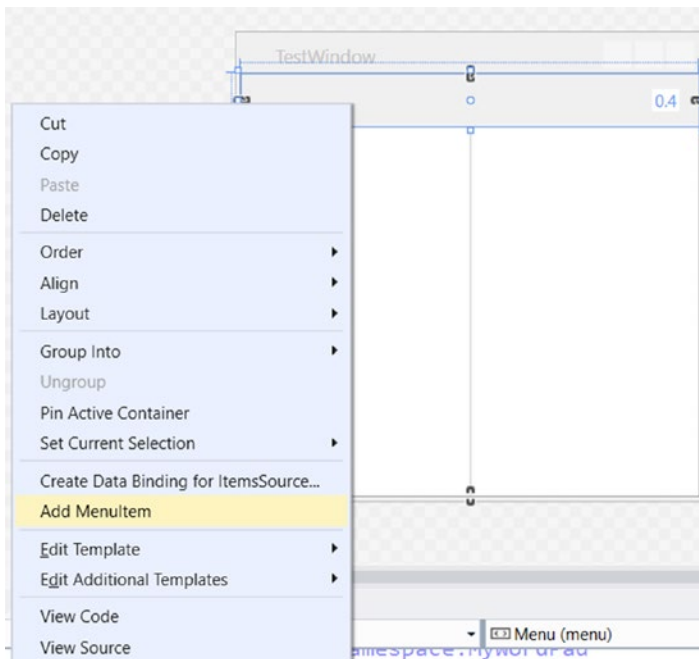

Figure 27-18. Visually adding items to a Menu object

After you have added a set of topmost items, you can then add submenu items, separators, expand or collapse the menu itself, and perform other menu-centric operations via a second right-click. Figure 27-19 shows one possible way to visually design a simple menu system (be sure you examine the generated XAML).

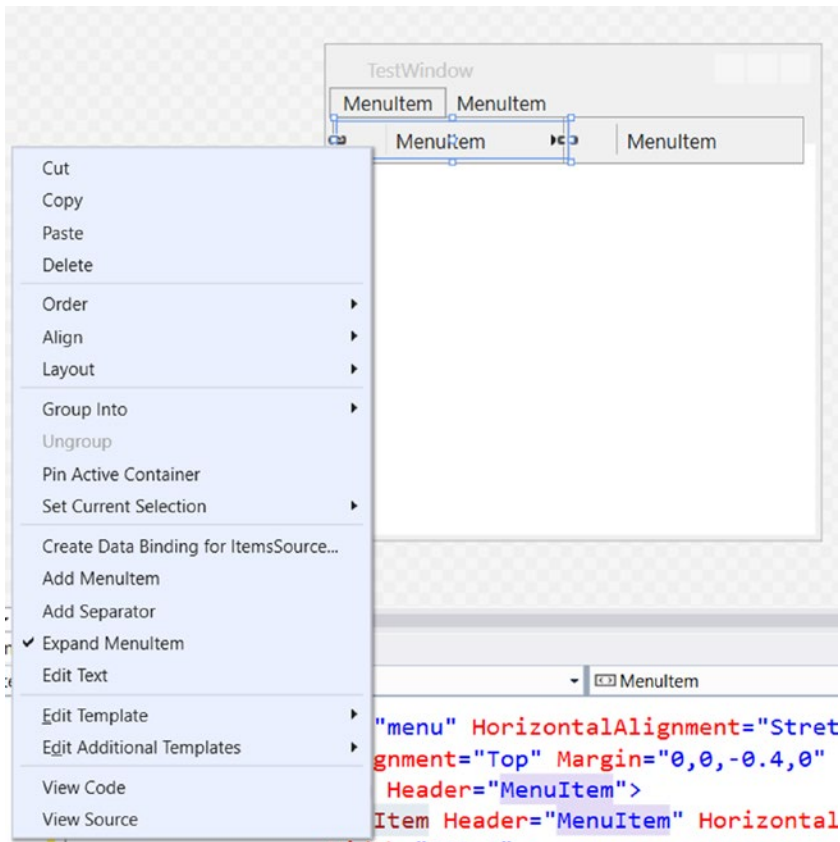

Figure 27-19. Visually adding items to a MenuItem object

As you read over the remainder of the current MyWordPad example, I'll typically show you the final generated XAML; however, do take the time to experiment with the visual designers to simplify the task at hand.

Building the ToolBar

Toolbars (represented by the `ToolBar` class in WPF) typically provide an alternative manner for activating a menu option. Add the following markup directly after the closing scope of your `<Menu>` definition:

```
<!-- Put Toolbar under the Menu -->
<ToolBar DockPanel.Dock ="Top" >
  <Button Content ="Exit" MouseEnter ="MouseEnterExitArea"
    MouseLeave ="MouseLeaveArea" Click ="FileExit_Click"/>
  <Separator/>
```



```

<Button Content ="Check" MouseEnter ="MouseEnterToolsHintsArea"
        MouseLeave ="MouseLeaveArea" Click ="ToolsSpellingHints_Click"
        Cursor="Help" />
</ToolBar>

```

Your `ToolBar` control consists of two `Button` controls, which just so happen to handle the same events and are handled by the same methods in your code file. Using this technique, you can double-up your handlers to serve both menu items and toolbar buttons. Although this toolbar uses the typical push buttons, you should appreciate that the `ToolBar` type “is-a” `ContentControl`; therefore, you are free to embed any types into its surface (e.g., drop-down lists, images, and graphics). The only other point of interest here is that the `Check` button supports a custom mouse cursor through the `Cursor` property.

■ **Note** You can optionally wrap the `ToolBar` element within a `<ToolBarTray>` element, which controls layout, docking, and drag-and-drop operations for a set of `ToolBar` objects. Consult the .NET Framework 4.6 SDK documentation for details.

Building the StatusBar

A `StatusBar` control will be docked to the lower portion of the `<DockPanel>` and contain a single `<TextBlock>` control, which you have not used prior to this point in the chapter. You can use a `TextBlock` to hold text that supports numerous textual annotations, such as bold text, underlined text, line breaks, and so forth. Add the following markup directly after the previous `ToolBar` definition:

```

<!-- Put a StatusBar at the bottom -->
<StatusBar DockPanel.Dock ="Bottom" Background="Beige" >
  <StatusBarItem>
    <TextBlock Name="statBarText" Text="Ready"/>
  </StatusBarItem>
</StatusBar>

```

Finalizing the UI Design

The final aspect of your UI design is to define a splittable `Grid` that defines two columns. On the left, place an `Expander` control that will display a list of spelling suggestions, wrapped within a `<StackPanel>`. On the right, place a `TextBox` control that supports multiple lines and scrollbars, and includes enabled spell checking. You mount the entire `<Grid>` to the left of the parent `<DockPanel>`. Add the following XAML markup directly under the markup describing the `StatusBar` to complete the definition of your window’s UI:

```

<Grid DockPanel.Dock ="Left" Background ="AliceBlue">
  <!-- Define the rows and columns -->
  <Grid.ColumnDefinitions>
    <ColumnDefinition />
    <ColumnDefinition />
  </Grid.ColumnDefinitions>

```

```

<GridSplitter Grid.Column = "0" Width = "5" Background = "Gray" />
<StackPanel Grid.Column="0" VerticalAlignment = "Stretch" >
  <Label Name="lblSpellingInstructions" FontSize="14" Margin="10,10,0,0">
    Spelling Hints
  </Label>

  <Expander Name="expanderSpelling" Header = "Try these!"
    Margin="10,10,10,10">
    <!-- This will be filled programmatically -->
    <Label Name = "lblSpellingHints" FontSize = "12"/>
  </Expander>
</StackPanel>

<!-- This will be the area to type within -->
<TextBox Grid.Column = "1"
  SpellCheck.IsEnabled = "True"
  AcceptsReturn = "True"
  Name = "txtData" FontSize = "14"
  BorderBrush = "Blue"
  VerticalScrollBarVisibility="Auto"
  HorizontalScrollBarVisibility="Auto">
</TextBox>
</Grid>

```

Implementing the MouseEnter/MouseLeave Event Handlers

At this point, the UI of your window is complete. The only remaining tasks are to provide an implementation for the remaining event handlers. Begin by updating your C# code file so that each of the MouseEnter, MouseLeave, and MouseExit handlers set the text pane of the status bar with a fitting message to help the end user, like so:

```

public partial class MainWindow : System.Windows.Window
{
  ...
  protected void MouseEnterExitArea(object sender, RoutedEventArgs args)
  {
    statBarText.Text = "Exit the Application";
  }
  protected void MouseEnterToolsHintsArea(object sender, RoutedEventArgs args)
  {
    statBarText.Text = "Show Spelling Suggestions";
  }
  protected void MouseLeaveArea(object sender, RoutedEventArgs args)
  {
    statBarText.Text = "Ready";
  }
}

```

At this point, you can run your application. You should see your status bar change its text based on which menu item/toolbar button you hover your mouse over.

Implementing the Spell Checking Logic

The WPF API ships with built-in spell checker support, which is independent of Microsoft Office products. This means you don't need to use the COM interop layer to use the spell checker of Microsoft Word; instead, you can easily add the same type of support with only a few lines of code.

You might recall that when you defined the <TextBox> control, you set the `SpellCheck.IsEnabled` property to `true`. When you do this, misspelled words are underlined with a red squiggle, just as they are in Microsoft Office. Even better, the underlying programming model gives you access to the spell-checker engine, which allows you to get a list of suggestions for misspelled words. Add the following code to your `ToolsSpellingHints_Click()` method:

```
protected void ToolsSpellingHints_Click(object sender, RoutedEventArgs args)
{
    string spellingHints = string.Empty;

    // Try to get a spelling error at the current caret location.
    SpellingError error = txtData.GetSpellingError(txtData.CaretIndex);
    if (error != null)
    {
        // Build a string of spelling suggestions.
        foreach (string s in error.Suggestions)
        {
            spellingHints += $"{s}\n";
        }

        // Show suggestions and expand the expander.
        lblSpellingHints.Content = spellingHints;
        expanderSpelling.IsExpanded = true;
    }
}
```

The preceding code is quite simple. You simply figure out the current location of the caret in the text box by using the `CaretIndex` property to extract a `SpellingError` object. If there is an error at said location (meaning the value is not null), you loop over the list of suggestions using the aptly named `Suggestions` property. After you have all of the suggestions for the misspelled word, you connect the data to the `Label` in the `Expander`.

So there you have it! With only a few lines of procedural code (and a healthy dose of XAML), you have the beginnings of a functioning word processor. An understanding of *control commands* can help you add a bit more pizzazz.

Understanding WPF Commands

Windows Presentation Foundation provides support for what might be considered *control-agnostic events* via the *command architecture*. A typical .NET event is defined within a specific base class and can be used only by that class or a derivative thereof. Therefore, normal .NET events are tightly coupled to the class in which they are defined.

In contrast, WPF commands are event-like entities that are independent from a specific control and, in many cases, can be successfully applied to numerous (and seemingly unrelated) control types. By way of a few examples, WPF supports copy, paste, and cut commands, which you can apply to a wide variety of UI elements (e.g., menu items, toolbar buttons, and custom buttons), as well as keyboard shortcuts (e.g., Ctrl+C and Ctrl+V).

While other UI toolkits (such as Windows Forms) provided standard events for such purposes, using them typically left you with redundant and hard-to-maintain code. Under the WPF model, you can use commands as an alternative. The end result typically yields a smaller and more flexible code base.

The Intrinsic Command Objects

WPF ships with numerous built-in control commands, all of which you can configure with associated keyboard shortcuts (or other input gestures). Programmatically speaking, a WPF command is any object that supports a property (often called `Command`) that returns an object implementing the `ICommand` interface, as shown here:

```
public interface ICommand
{
    // Occurs when changes occur that affect whether
    // or not the command should execute.
    event EventHandler CanExecuteChanged;

    // Defines the method that determines whether the command
    // can execute in its current state.
    bool CanExecute(object parameter);

    // Defines the method to be called when the command is invoked.
    void Execute(object parameter);
}
```

WPF provides various command classes, which expose close to 100 command objects, out of the box. These classes define numerous properties that expose specific command objects, each of which implements `ICommand`. Table 27-3 documents some of the standard command objects available (be sure to consult the .NET Framework 4.6 SDK documentation for complete details).

Table 27-3. *The Intrinsic WPF Control Command Objects*

| WPF Class | Command Objects | Meaning in Life |
|---------------------|---|---|
| ApplicationCommands | Close, Copy, Cut, Delete, Find, Open, Paste, Save, SaveAs, Redo, Undo | Various application-level commands |
| ComponentCommands | MoveDown, MoveFocusBack, MoveLeft, MoveRight, ScrollToEnd, ScrollToHome | Various commands common to UI components |
| MediaCommands | BoostBase, ChannelUp, ChannelDown, FastForward, NextTrack, Play, Rewind, Select, Stop | Various media-centric commands |
| NavigationCommands | BrowseBack, BrowseForward, Favorites, LastPage, NextPage, Zoom | Various commands relating to the WPF navigation model |
| EditingCommands | AlignCenter, CorrectSpellingError, DecreaseFontSize, EnterLineBreak, EnterParagraphBreak, MoveDownByLine, MoveRightByWord | Various commands relating to the WPF Documents API |

Connecting Commands to the Command Property

If you want to connect any of the WPF command properties to a UI element that supports the `Command` property (such as a `Button` or `MenuItem`), you have very little work to do. You can see how to do this by updating the current menu system so it supports a new topmost menu item named `Edit` and three subitems to account for copying, pasting, and cutting of textual data, like so:

```
<Menu DockPanel.Dock = "Top"
    HorizontalAlignment="Left"
    Background="White" BorderBrush ="Black">
  <MenuItem Header="_File" Click ="FileExit_Click" >
    <MenuItem Header ="_Exit" MouseEnter ="MouseEnterExitArea"
      MouseLeave ="MouseLeaveArea" Click ="FileExit_Click"/>
  </MenuItem>

  <!-- New menu item with commands! -->
  <MenuItem Header="_Edit">
    <MenuItem Command ="ApplicationCommands.Copy"/>
    <MenuItem Command ="ApplicationCommands.Cut"/>
    <MenuItem Command ="ApplicationCommands.Paste"/>
  </MenuItem>

  <MenuItem Header="_Tools">
    <MenuItem Header ="_Spelling Hints"
      MouseEnter ="MouseEnterToolsHintsArea"
      MouseLeave ="MouseLeaveArea"
      Click ="ToolsSpellingHints_Click"/>
  </MenuItem>
</Menu>
```

Notice that each of the subitems on the `Edit` menu has a value assigned to the `Command` property. Doing this means that the menu items automatically receive the correct name and shortcut key (e.g., `Ctrl+C` for a cut operation) in the menu item UI; it also means that the application is now *copy*, *cut*, and *paste*-aware with no procedural code!

If you run the application and select some of text, you can use your new menu items out of the box. As a bonus, your application is also equipped to respond to a standard right-click operation to present the user with the same options (see Figure 27-20).

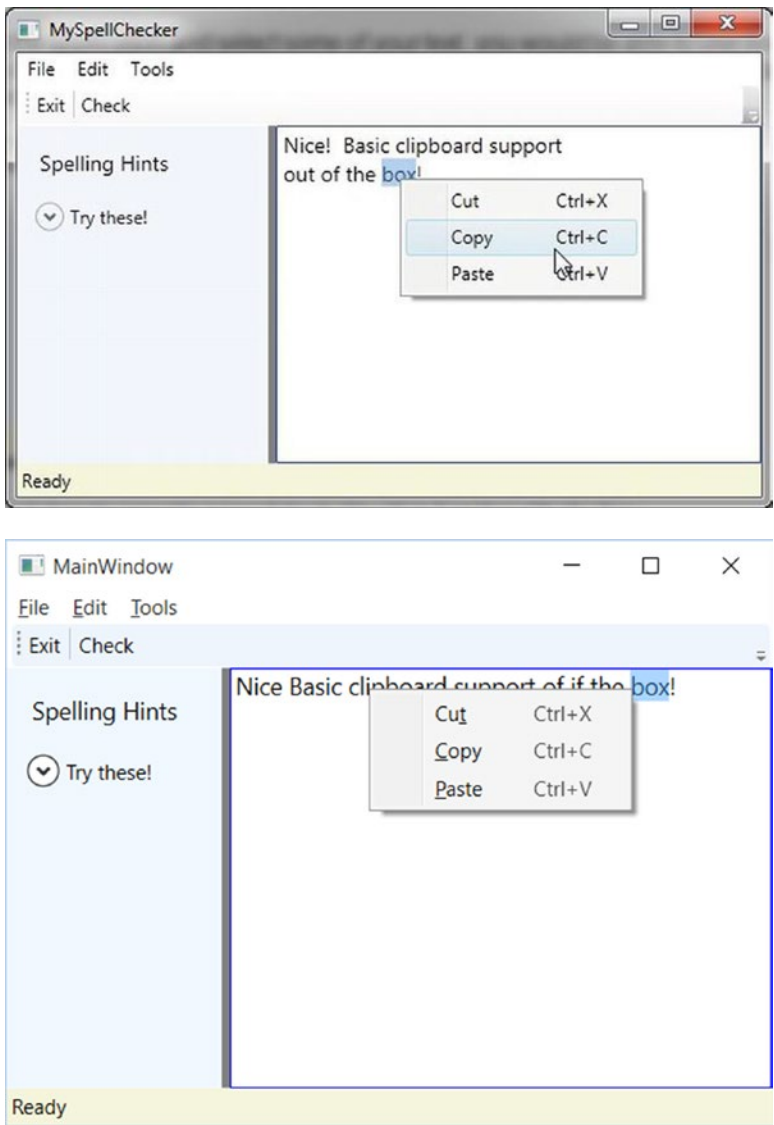

Figure 27-20. Command objects provide a good deal of built-in functionality for free

Connecting Commands to Arbitrary Actions

If you want to connect a command object to an arbitrary (application-specific) event, you will need to drop down to procedural code. Doing so is not complex, but it does involve a bit more logic than you see in XAML. For example, assume that you want to have the entire window respond to the F1 key, so that when the end user presses this key, he will activate an associated help system. Also, assume your code file for the main window defines a new method named `SetF1CommandBinding()`, which you call within the constructor after the call to `InitializeComponent()`.

```
public MainWindow()
{
    InitializeComponent();
    SetF1CommandBinding();
}
```

This new method will programmatically create a new `CommandBinding` object, which you can use whenever you need to bind a command object to a given event handler in your application. Here, you configure your `CommandBinding` object to operate with the `ApplicationCommands.Help` command, which is automatically F1-aware:

```
private void SetF1CommandBinding()
{
    CommandBinding helpBinding = new CommandBinding(ApplicationCommands.Help);
    helpBinding.CanExecute += CanHelpExecute;
    helpBinding.Executed += HelpExecuted;
    CommandBindings.Add(helpBinding);
}
```

Most `CommandBinding` objects will want to handle the `CanExecute` event (which allows you to specify whether the command occurs based on the operation of your program) and the `Executed` event (which is where you can author the content that should occur once the command occurs). Add the following event handlers to your `Window`-derived type (note the format of each method, as required by the associated delegates):

```
private void CanHelpExecute(object sender, CanExecuteRoutedEventArgs e)
{
    // Here, you can set CanExecute to false if you want to prevent the
    // command from executing.
    e.CanExecute = true;
}

private void HelpExecuted(object sender, ExecutedRoutedEventArgs e)
{
    MessageBox.Show("Look, it is not that difficult. Just type something!",
        "Help!");
}
```

In the preceding snippet, you implemented `CanHelpExecute()` so it always allows F1 help to launch; you do this by simply returning `true`. However, if you have certain situations where the help system should not display, you can account for this and return `false` when necessary. Your “help system” displayed within `HelpExecuted()` is little more than a message box. At this point, you can run your application. When you press the F1 key on your keyboard, you will see your (less than helpful, if not a bit insulting) user-guidance system (see Figure 27-21).

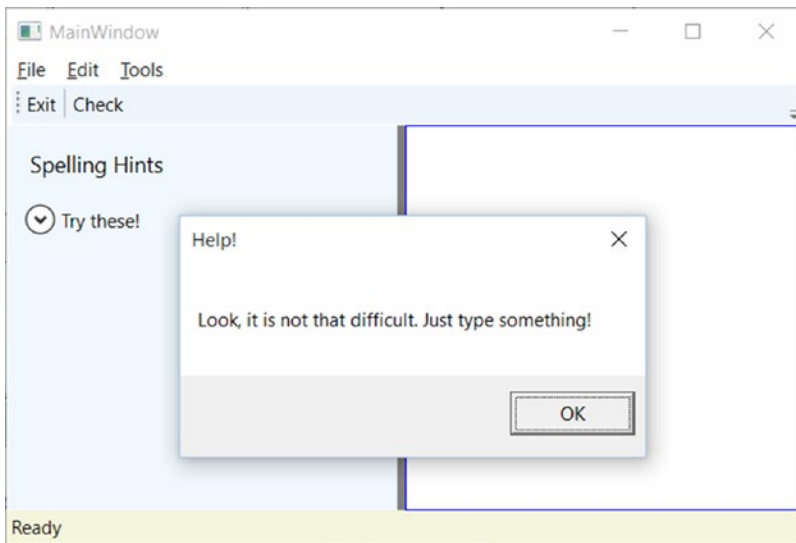

Figure 27-21. Your custom help system (which might not be as helpful as the user would hope)

Working with the Open and Save Commands

To complete the current example, you will add functionality to save your text data to an external file and open up *.txt files for editing. If you want to take the long road, you can manually add programming logic that enables or disables new menu items based on whether your `TextBox` has data inside it. Once again, however, you can use commands to decrease your burden.

Begin by updating the `<MenuItem>` element that represents your topmost File menu by adding the following two new submenus that use the `Save` and `Open ApplicationCommands` objects:

```
<MenuItem Header="_ File">
  <MenuItem Command ="ApplicationCommands.Open"/>
  <MenuItem Command ="ApplicationCommands.Save"/>
  <Separator/>
  <MenuItem Header ="_ Exit"
    MouseEnter ="MouseEnterExitArea"
    MouseLeave ="MouseLeaveArea" Click ="FileExit_Click"/>
</MenuItem>
```

Again, remember that all command objects implement the `ICommand` interface, which defines two events (`CanExecute` and `Executed`). Now you need to enable the entire window, so it can check whether it is currently okay to fire these commands; if so, you can define an event handler to execute the custom code.

You do this by populating the `CommandBindings` collection maintained by the window. To do so in XAML requires that you use property element syntax to define a `<Window.CommandBindings>` scope in which you place two `<CommandBinding>` definitions. Update your `<Window>` like this:

```
<Window x:Class="MyWordPad.MainWindow"
  xmlns="http://schemas.microsoft.com/winfx/2006/xaml/presentation"
  xmlns:x="http://schemas.microsoft.com/winfx/2006/xaml"
```



```

Title="MySpellChecker" Height="331" Width="508"
WindowStartupLocation ="CenterScreen" >

<!-- This will inform the Window which handlers to call,
when testing for the Open and Save commands. -->
<Window.CommandBindings>
  <CommandBinding Command="ApplicationCommands.Open"
    Executed="OpenCmdExecuted"
    CanExecute="OpenCmdCanExecute"/>
  <CommandBinding Command="ApplicationCommands.Save"
    Executed="SaveCmdExecuted"
    CanExecute="SaveCmdCanExecute"/>
</Window.CommandBindings>

<!-- This panel establishes the content for the window -->
<DockPanel>
...
</DockPanel>
</Window>

```

Now right-click each of the Executed and CanExecute attributes in your XAML editor and pick the Navigate to Event Handler menu option. As you might recall from Chapter 26, this will automatically generate stub code for the event itself. At this point, you should have four empty handlers in the C# code file for the window.

The implementation of CanExecute event handlers will tell the window that it is okay to fire the corresponding Executed events at any time by setting the CanExecute property of the incoming CanExecuteRoutedEventArgs object.

```

private void OpenCmdCanExecute(object sender, CanExecuteRoutedEventArgs e)
{
    e.CanExecute = true;
}

private void SaveCmdCanExecute(object sender, CanExecuteRoutedEventArgs e)
{
    e.CanExecute = true;
}

```

The corresponding Executed handlers perform the actual work of displaying the open and save dialog boxes; they also send the data in your TextBox to a file. Begin by making sure that you import the System.IO and Microsoft.Win32 namespaces into your code file. The following completed code is straightforward:

```

private void OpenCmdExecuted(object sender, ExecutedRoutedEventArgs e)
{
    // Create an open file dialog box and only show XAML files.
    var openDlg = new OpenFileDialog { Filter = "Text Files (*.txt)"};

    // Did they click on the OK button?
    if (true == openDlg.ShowDialog())
    {
        // Load all text of selected file.
        string dataFromFile = File.ReadAllText(openDlg.FileName);
    }
}

```

```

    // Show string in TextBox.
    txtData.Text = dataFromFile;
}
}

private void SaveCmdExecuted(object sender, ExecutedRoutedEventArgs e)
{
    var saveDlg = new SaveFileDialog { Filter = "Text Files (*.txt)";

    // Did they click on the OK button?
    if (true == saveDlg.ShowDialog())
    {
        // Save data in the TextBox to the named file.
        File.WriteAllText(saveDlg.FileName, txtData.Text);
    }
}
}

```

■ **Note** Chapter 30 will take a much deeper look into the WPF command system. In it, you will create custom commands base on `ICommand` as well as `RelayCommands`.

That wraps up this example and your initial look at working with WPF controls. Here, you learned how to work with basic commands, menu systems, status bars, toolbars, nested panels, and a few basic UI controls, such as `TextBox` and `Expander`. The next example will work with some more exotic controls, while examining several important WPF services at the same time.

■ **Source Code** You can find the `MyWordPad` project in the Chapter 27 subdirectory.

Understanding Routed Events

You might have noticed the `RoutedEventArgs` parameter instead of `EventArgs` in the previous code example. The routed events model is a refinement of the standard CLR event model designed to ensure that events can be processed in a manner that is fitting for XAML's description of a tree of objects. Assume you have a new WPF application project named `WPF Routed Events`. Now, update the XAML description of the initial window by adding the following `<Button>` control, which defines some complex content:

```

<Button Name="btnClickMe" Height="75" Width = "250"
    Click = "btnClickMe_Clicked">
    <StackPanel Orientation ="Horizontal">
    <Label Height="50" FontSize ="20">Fancy Button!</Label>
    <Canvas Height ="50" Width ="100" >
    <Ellipse Name = "outerEllipse" Fill ="Green" Height ="25"
        Width ="50" Cursor="Hand" Canvas.Left="25" Canvas.Top="12"/>
    <Ellipse Name = "innerEllipse" Fill ="Yellow" Height = "15" Width ="36"
        Canvas.Top="17" Canvas.Left="32"/>
    </Canvas>
    </StackPanel>
</Button>

```

Notice in the <Button>'s opening definition you have handled the Click event by specifying the name of a method to be called when the event is raised. The Click event works with the RoutedEventHandler delegate, which expects an event handler that takes an object as the first parameter and a System.Windows.RoutedEventArgs as the second. Implement this handler as so:

```
public void btnClickMe_Clicked(object sender, RoutedEventArgs e)
{
    // Do something when button is clicked.
    MessageBox.Show("Clicked the button");
}
```

If you run your application, you will see this message box display, regardless of which part of the button's content you click (the green Ellipse, the yellow Ellipse, the Label, or the Button's surface). This is a good thing. Imagine how tedious WPF event handling would be if you were forced to handle a Click event for every one of these subelements. Not only would the creation of separate event handlers for each aspect of the Button be labor intensive, you would end up with some mighty nasty code to maintain down the road.

Thankfully, WPF *routed events* take care of ensuring that your single Click event handler will be called regardless of which part of the button is clicked automatically. Simply put, the routed events model automatically propagates an event up (or down) a tree of objects, looking for an appropriate handler.

Specifically speaking, a routed event can make use of three *routing strategies*. If an event is moving from the point of origin up to other defining scopes within the object tree, the event is said to be a *bubbling event*. Conversely, if an event is moving from the outermost element (e.g., a Window) down to the point of origin, the event is said to be a *tunneling event*. Finally, if an event is raised and handled only by the originating element (which is what could be described as a normal CLR event), it is said to be a *direct event*.

The Role of Routed Bubbling Events

In the current example, if the user clicks the inner yellow oval, the Click event bubbles out to the next level of scope (the Canvas), then to the StackPanel, and finally to the Button where the Click event handler is handled. In a similar way, if the user clicks the Label, the event is bubbled to the StackPanel and then finally to the Button element.

Given this bubbling routed event pattern, you have no need to worry about registering specific Click event handlers for all members of a composite control. However, if you want to perform custom clicking logic for multiple elements within the same object tree, you can do so.

By way of illustration, assume you need to handle the clicking of the outerEllipse control in a unique manner. First, handle the MouseDown event for this subelement (graphically rendered types such as the Ellipse do not support a Click event; however, they can monitor mouse button activity via MouseDown, MouseUp, etc.).

```
<Button Name="btnClickMe" Height="75" Width = "250"
    Click ="btnClickMe_Clicked">
  <StackPanel Orientation ="Horizontal">
    <Label Height="50" FontSize ="20">Fancy Button!</Label>
    <Canvas Height ="50" Width ="100" >
      <Ellipse Name = "outerEllipse" Fill ="Green"
        Height ="25" MouseDown ="outerEllipse_MouseDown"
        Width ="50" Cursor="Hand" Canvas.Left="25" Canvas.Top="12"/>
      <Ellipse Name = "innerEllipse" Fill ="Yellow" Height = "15" Width ="36"
        Canvas.Top="17" Canvas.Left="32"/>
    </Canvas>
  </StackPanel>
</Button>
```

Then implement an appropriate event handler, which for illustrative purposes will simply change the `Title` property of the main window, like so:

```
public void outerEllipse_MouseDown(object sender, MouseButtonEventArgs e)
{
    // Change title of window.
    this.Title = "You clicked the outer ellipse!";
}
```

With this, you can now take different courses of action depending on where the end user has clicked (which boils down to the outer ellipse and everywhere else within the button's scope).

■ **Note** Routed bubbling events always move from the point of origin to the *next defining scope*. Thus, in this example, if you click the `innerEllipse` object, the event will be bubbled to the `Canvas`, *not* to the `outerEllipse` because they are both `Ellipse` types within the scope of `Canvas`.

Continuing or Halting Bubbling

Currently, if the user clicks the `outerEllipse` object, it will trigger the registered `MouseDown` event handler for this `Ellipse` object, at which point the event bubbles to the button's `Click` event. If you want to inform WPF to stop bubbling up the tree of objects, you can set the `Handled` property of the `EventArgs` parameter to `true`, as follows:

```
public void outerEllipse_MouseDown(object sender, MouseButtonEventArgs e)
{
    // Change title of window.
    this.Title = "You clicked the outer ellipse!";

    // Stop bubbling!
    e.Handled = true;
}
```

In this case, you would find that the title of the window is changed, but you will not see the `MessageBox` displayed by the `Click` event handler of the `Button`. In a nutshell, routed bubbling events make it possible to allow a complex group of content to act either as a single logical element (e.g., a `Button`) or as discrete items (e.g., an `Ellipse` within the `Button`).

The Role of Routed Tunneling Events

Strictly speaking, routed events can be *bubbling* (as just described) or *tunneling* in nature. Tunneling events (which all begin with the `Preview` suffix—e.g., `PreviewMouseDown`) drill down from the topmost element into the inner scopes of the object tree. By and large, each bubbling event in the WPF base class libraries is paired with a related tunneling event that fires *before* the bubbling counterpart. For example, before the bubbling `MouseDown` event fires, the tunneling `PreviewMouseDown` event fires first.

Handling a tunneling event looks just like the processing of handling any other events; simply assign the event handler name in XAML (or, if needed, use the corresponding C# event-handling syntax in your code file) and implement the handler in the code file. Just to illustrate the interplay of tunneling and bubbling events, begin by handling the `PreviewMouseDown` event for the `outerEllipse` object, like so:

```
<Ellipse Name = "outerEllipse" Fill = "Green" Height = "25"
    MouseDown = "outerEllipse_MouseDown"
    PreviewMouseDown = "outerEllipse_PreviewMouseDown"
    Width = "50" Cursor = "Hand" Canvas.Left = "25" Canvas.Top = "12" />
```

Next, retrofit the current C# class definition by updating each event handler (for all objects) to append data about the current event into a string member variable named `mouseActivity`, using the incoming event args object. This will allow you to observe the flow of events firing in the background.

```
public partial class MainWindow : Window
{
    string _mouseActivity = string.Empty;
    public MainWindow()
    {
        InitializeComponent();
    }

    public void btnClickMe_Clicked(object sender, RoutedEventArgs e)
    {
        AddEventInfo(sender, e);
        MessageBox.Show(_mouseActivity, "Your Event Info");

        // Clear string for next round.
        _mouseActivity = "";
    }

    private void AddEventInfo(object sender, RoutedEventArgs e)
    {
        _mouseActivity += string.Format(
            "{0} sent a {1} event named {2}.\n", sender,
            e.RoutedEvent.RoutingStrategy,
            e.RoutedEvent.Name);
    }

    private void outerEllipse_MouseDown(object sender, MouseButtonEventArgs e)
    {
        AddEventInfo(sender, e);
    }

    private void outerEllipse_PreviewMouseDown(object sender, MouseButtonEventArgs e)
    {
        AddEventInfo(sender, e);
    }
}
```

Notice that you are not halting the bubbling of an event for any event handler. If you run this application, you will see a unique message box display based on where you click the button. Figure 27-22 shows the result of clicking the outer `Ellipse` object.

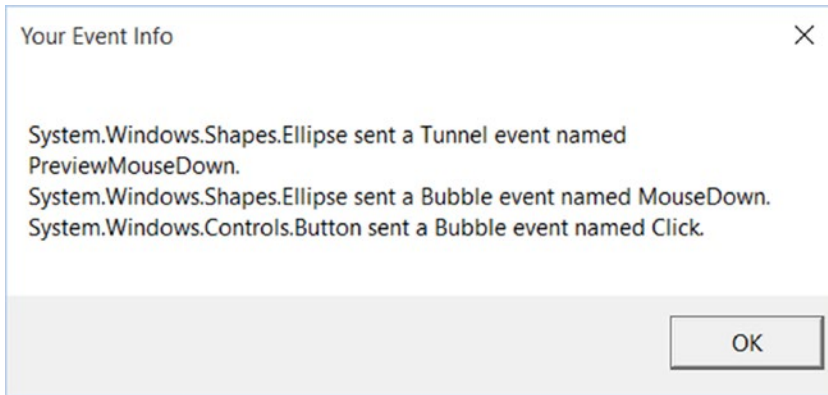

Figure 27-22. Tunneling first, bubbling second

So, why do WPF events typically tend to come in pairs (one tunneling and one bubbling)? The answer is that by previewing events, you have the power to perform any special logic (data validation, disable bubbling action, etc.) before the bubbling counterpart fires. By way of an example, assume you have a `TextBox` that should contain only numerical data. You could handle the `PreviewKeyDown` event, and if you see the user has entered nonnumerical data, you could cancel the bubbling event by setting the `Handled` property to `true`.

As you would guess, when you are building a custom control that contains custom events, you could author the event in such a way that it can bubble (or tunnel) through a tree of XAML. For the purpose of this chapter, I will not be examining how to build custom routed events (however, the process is not that different from building a custom dependency property). If you are interested, check out the topic “Routed Events Overview” within the .NET Framework 4.5 SDK documentation. In it you will find a number of tutorials that will help you on your way.

■ **Source Code** The `WpfroutedEvents` project is included in the Chapter 27 subdirectory.

A Deeper Look at WPF APIs and Controls

The remainder of this chapter will give you a chance to build a brand-new WPF application using Visual Studio. The goal is to create a UI that consists of a `TabControl` widget containing a set of tabs. Each tab will illustrate some new WPF controls and interesting APIs you might want to make use of in your software projects. Along the way, you will also learn additional features of the Visual Studio WPF designers.

Working with the `TabControl`

To get started, create a new WPF application named `WpfControlsAndAPIs`. As mentioned, your initial window will contain a `TabControl` with four different tabs, each of which shows off a set of related controls and/or WPF APIs. Locate the `TabControl` control in the Visual Studio toolbox, drop one onto your designer, resize the component to take up a majority of the display area, and rename this UI element to `myTabSystem`.

You will notice that you are given two tab items automatically. In order to add additional tabs, you simply need to right-click the `TabControl` node in the Document Outline window and select the `Add TabItem` menu option (you can also right-click the `TabControl` on the designer to activate the same menu option). Add two additional tabs using either approach (Figure 27-23 shows the Designer approach).

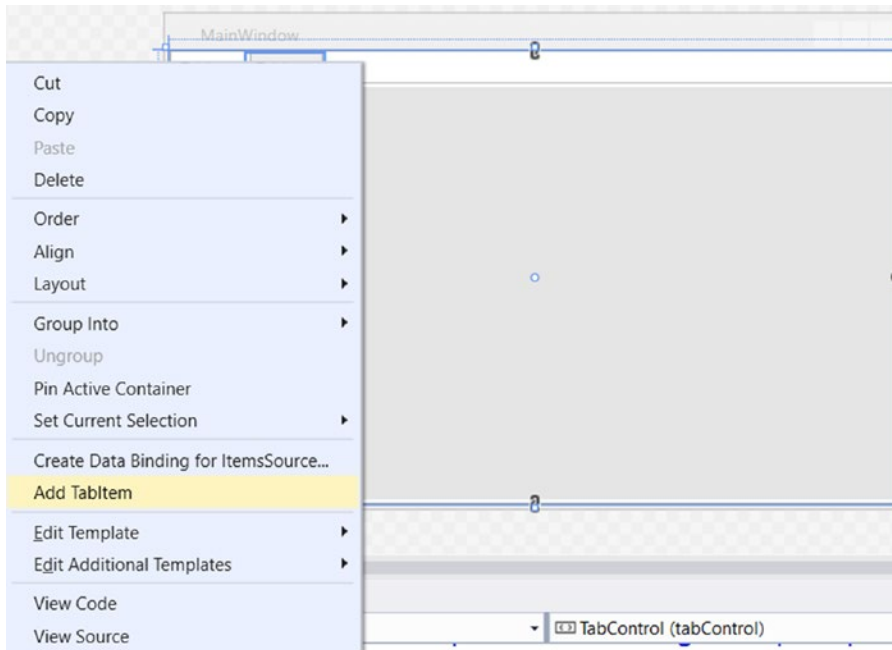

Figure 27-23. Visually adding `TabItems`

Now, select each `TabItem` control (on the designer or via the Document Outline window) and change the `Header` property for each tab, naming them `Ink API`, `Documents`, `Data Binding`, and `DataGrid`. At this point, your window designer should look like what you see in Figure 27-24.

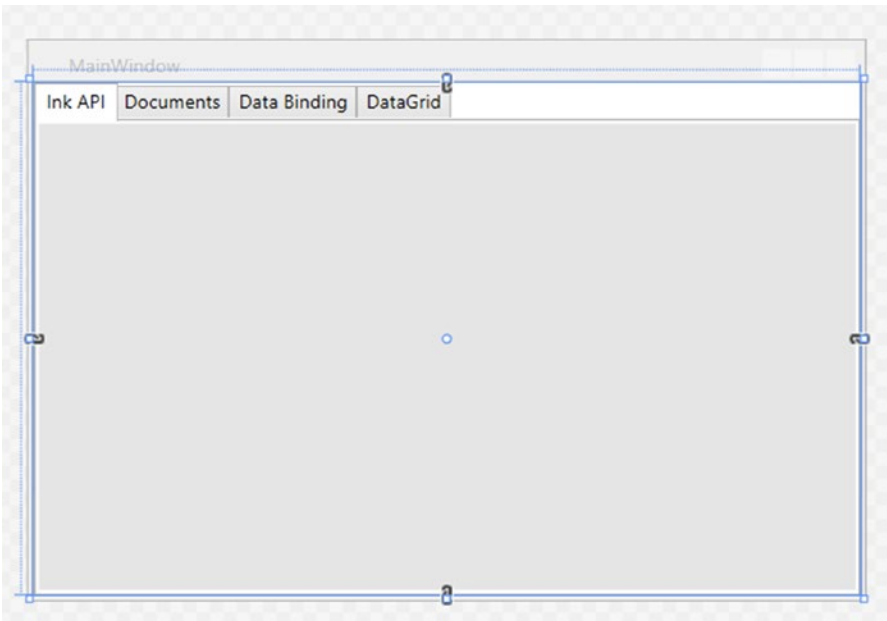

Figure 27-24. The initial layout of the tab system

Now click each tab again and use the Properties window to give each tab a unique, proper name. Be aware that when you select a tab for editing, that tab becomes the active tab, and you can design that tab by dragging controls from the Toolbox window. Before you begin to design each tab, take a peek at the XAML that the IDE generates on your behalf. You should see markup similar to the following (your markup might differ based on the properties you set):

```
<TabControl x:Name="myTabControl" HorizontalAlignment="Left" Height="280"
    Margin="10,10,0,0" VerticalAlignment="Top" Width="489">
  <TabItem Header="Ink API">
    <Grid Background="#FFE5E5E5"/>
  </TabItem>
  <TabItem Header="Documents">
    <Grid Background="#FFE5E5E5"/>
  </TabItem>
  <TabItem Header="Data Binding" HorizontalAlignment="Left" Height="20"
    VerticalAlignment="Top" Width="95" Margin="-2,-2,-36,0">
    <Grid Background="#FFE5E5E5"/>
  </TabItem>
  <TabItem Header="DataGrid" HorizontalAlignment="Left" Height="20"
    VerticalAlignment="Top" Width="74" Margin="-2,-2,-15,0">
    <Grid Background="#FFE5E5E5"/>
  </TabItem>
</TabControl>
```

Now that you have the core `TabControl` defined, you can work out the details tab by tab, and learn more features of the WPF API along the way.

Building the Ink API Tab

The first tab shows the overall role of WPF's digital Ink API, which allows you to incorporate painting functionality into a program easily. Of course, the application does not literally need to be a painting application; you can use this API for a wide variety of purposes, including capturing handwriting input with a stylus for a Tablet PC.

Begin by locating the node that represents the Ink API tab in your Document Outline area and expand it. You should see that the default layout manager for this TabItem is a <Grid>. Right-click this and change it to a StackPanel (see Figure 27-25).

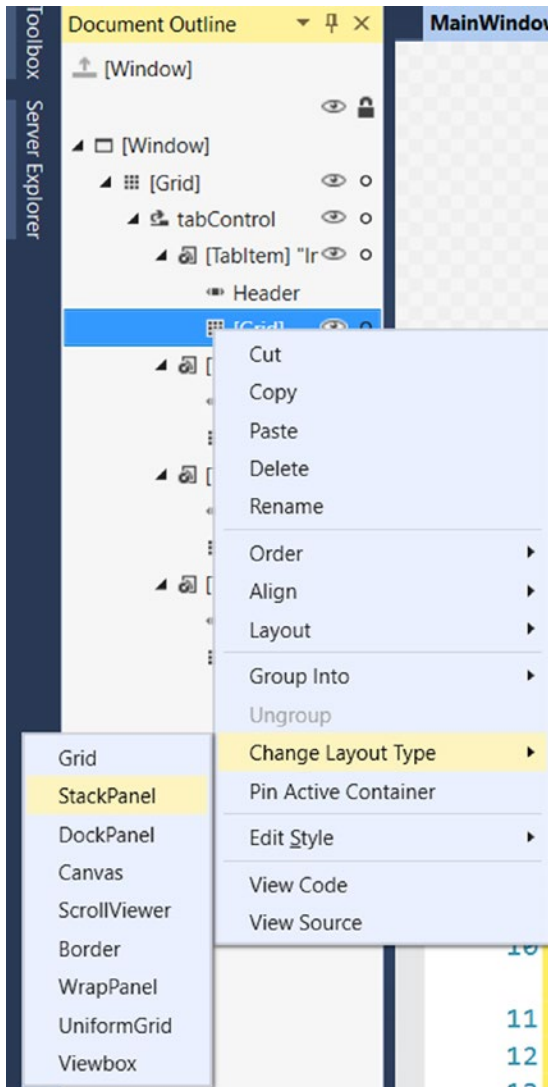

Figure 27-25. Changing the layout manager of the first tab item

Designing the ToolBar

Ensure that the StackPanel is the currently selected node in the Document Outline editor and insert a new ToolBar control named inkToolBar. Next, select the inkToolBar for editing and set the Height of the ToolBar control to 60 (the current Width value should be fine). Now find the Common section of the Properties window and click the ellipse button for the Items (Collection) property (see Figure 27-26).

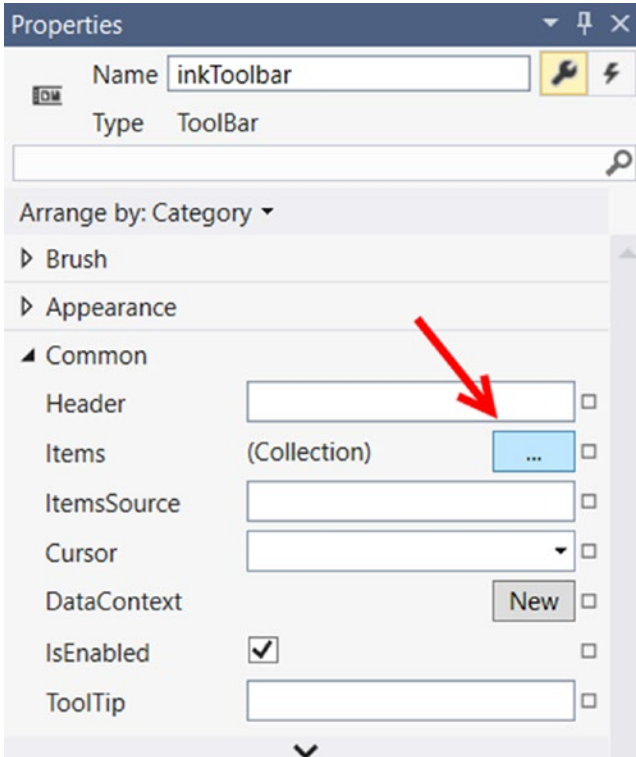

Figure 27-26. Populating the ToolBar with items begins here

After you click this button, you are presented with a dialog box that allows you to select the controls you want to add to the ToolBar. Click the drop-down list box on the bottom center of the dialog, and add three RadioButton controls. You can use the embedded Properties editor of this dialog to give each RadioButton a Height of 50 and a Width of 100 (again, you can find these properties in the Layout area). Also, set the Content property (located in the Common area) of each RadioButton to the values Ink Mode!, Erase Mode!, and Select Mode! (see Figure 27-27).

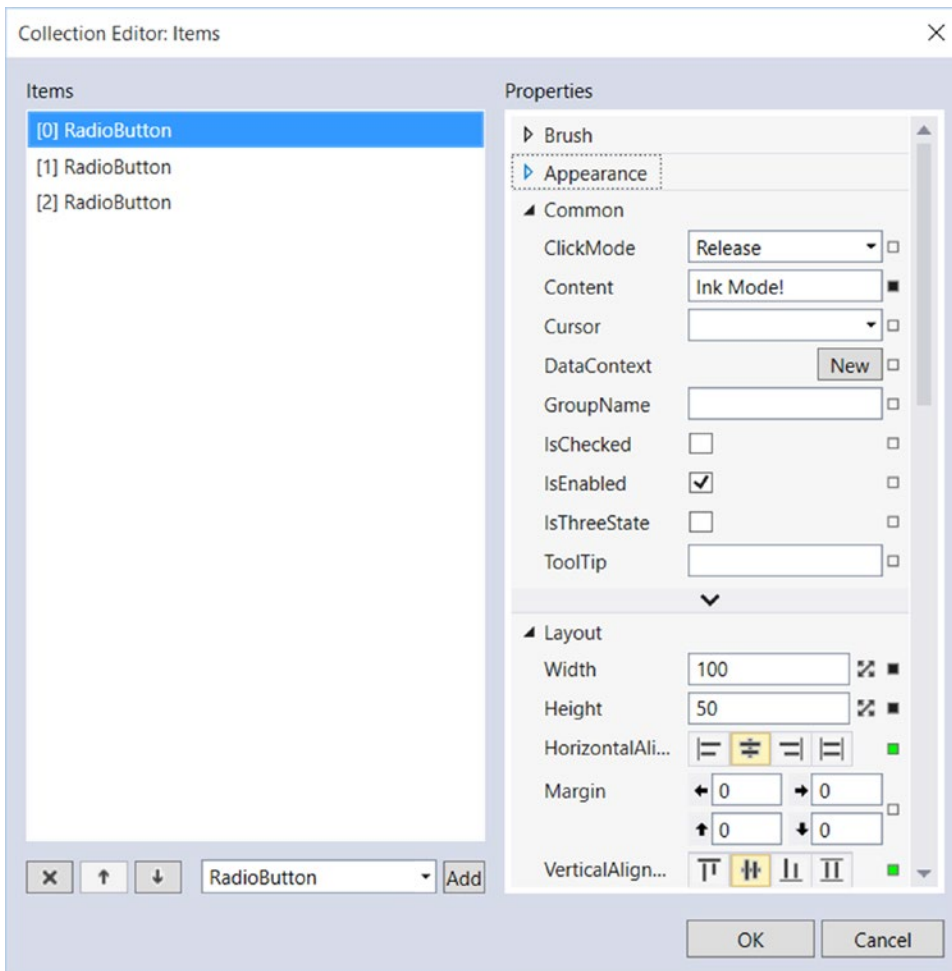

Figure 27-27. *Configuring each RadioButton*

After you add your three `RadioButton` controls, add a `Separator` control using the drop-down list of the Items editor. Now you need to add the final `ComboBox` (not `ComboBoxItem`) control listed in the drop-down. When you need to insert nonstandard controls using the Items dialog, just select the `<Other Type>` option from the drop-down. This opens the Select Object editor, where you can type in the name of the control you want. Make sure the Show all assemblies option is checked, and then do a search for your control of interest (see Figure 27-28).

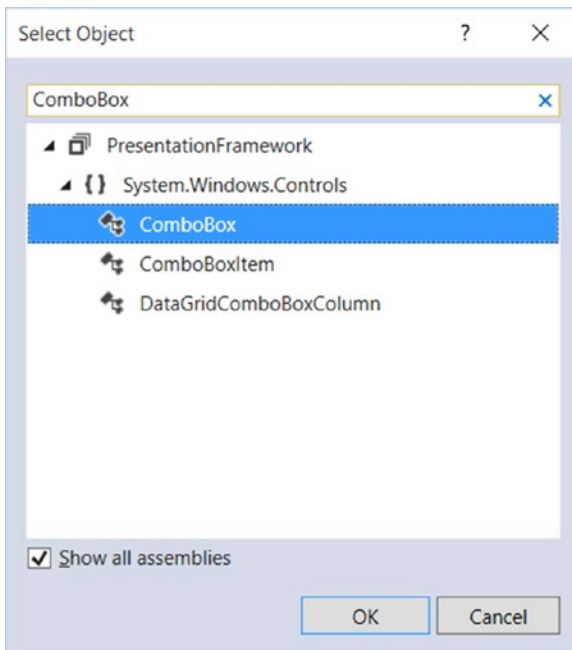

Figure 27-28. Using the Select Object editor to add unique items to the toolbar

Set the Width property of the ComboBox to 100 and add three ComboBoxItem objects to the ComboBox using the Items (Collection) property (again) in the Common section of the Properties editor. Set the Content property of each ComboBoxItem to the strings Red, Green, and Blue.

After you do this, close the editor to return to the window designer. The last task for this section is to use the Name property to assign variable names to your new items. Name your three RadioButton controls inkRadio, selectRadio, and eraseRadio. Also, name your ComboBox control comboColors. When all is said and done, the XAML for your first TabItem control should look similar to the following (you might need to adjust the width and height):

```
<TabItem Header="Ink API">
  <StackPanel Background="#FFE5E5E5">
    <ToolBar x:Name="inkToolBar" HorizontalAlignment="Left" Width="479" Height="60">
      <RadioButton x:Name="inkRadio" Content="Ink Mode!" Height="50" Width="100"/>
      <RadioButton x:Name="selectRadio" Content="Erase Mode!" Height="50" Width="100"/>
      <RadioButton x:Name="eraseRadio" Content="Select Mode!" Height="50" Width="100"/>
      <Separator/>
      <ComboBox x:Name="comboColors" Width="100">
        <ComboBoxItem Content="Red"/>
        <ComboBoxItem Content="Green"/>
        <ComboBoxItem Content="Blue"/>
      </ComboBox>
    </ToolBar>
  </StackPanel>
</TabItem>
```

■ **Note** As you built your toolbar using the IDE, you might have thought to yourself how much quicker your task would be if you could simply edit the XAML by hand. If you feel comfortable typing in the markup directly, you are certainly free to do so. However, I do encourage you to spend time becoming comfortable with the Visual Studio WPF Properties editor. As you will see, a number of advanced features are exposed via this editor.

The RadioButton Control

In this example, you want these three `RadioButton` controls to be mutually exclusive. In other GUI frameworks, ensuring that a group of related controls (such as radio buttons) were mutually exclusive required that you place them in the same group box. You don't need to do this under WPF. Instead, you can simply assign them all to the same *group name*. This is helpful because the related items do not need to be physically collected in the same area, but can be anywhere in the window.

Do this by selecting each `RadioButton` on the designer (you can select all three using a Shift-Click operation), and then setting the `GroupName` property (located in the Common Properties area of the Properties window) to `InkMode`.

When a `RadioButton` control is not placed inside of a parent panel control, it will take on a UI identical to a `Button` control! However, unlike a `Button`, the `RadioButton` class includes an `IsChecked` property, which toggles between `true` and `false` when the end user clicks the UI element. Furthermore, `RadioButton` provides two events (`Checked` and `Unchecked`) that you can use to intercept this state change.

To configure your `RadioButton` controls to look like typical radio buttons, select each control on the designer using a Shift+Click operation, then right-click the selection and pick the `Group Into Border` menu option (see Figure 27-29).

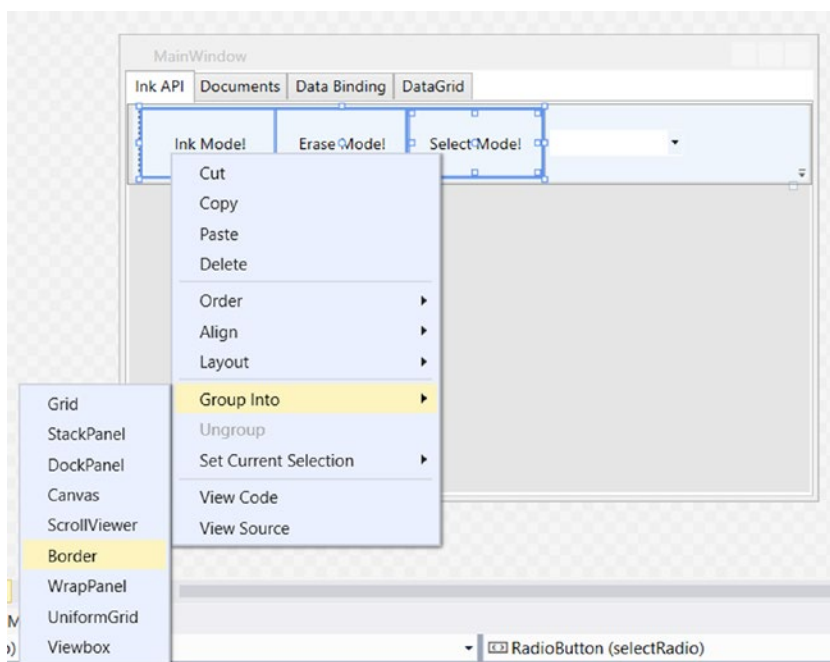

Figure 27-29. Grouping items in a `Border` control

At this point, you're ready to test the program, which you can do by pressing the F5 key. You should now see three mutually exclusive radio buttons and a combo box with three selections (see Figure 27-30).

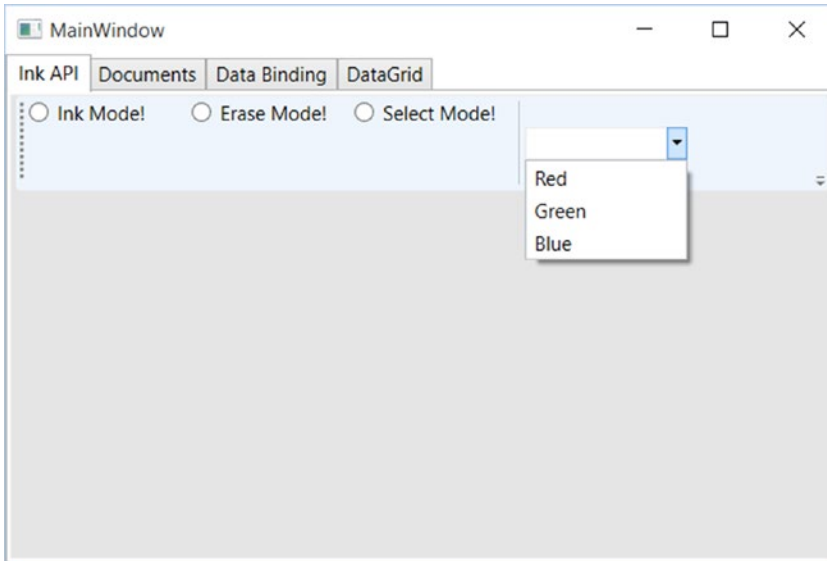

Figure 27-30. The completed toolbar system

Handling Events for the Ink API Tab

The next step for the Ink API tab is to handle the `Click` event for each `RadioButton` control. As you have done in other WPF projects in this book, simply select the Lightning Bolt button of the Visual Studio Properties editor to enter the names of event handlers. Using this approach, route the `Click` event for each button to the same handler, named `RadioButtonClicked`. After you handle all three `Click` events, handle the `SelectionChanged` event of the `ComboBox` using a handler named `ColorChanged`. When you finish, you should have the following C# code:

```
public partial class MainWindow : Window
{
    public MainWindow()
    {
        this.InitializeComponent();

        // Insert code required on object creation below this point.
    }
    private void RadioButtonClicked(object sender,RoutedEventArgs e)
    {
        // TODO: Add event handler implementation here.
    }
}
```

```
private void ColorChanged(object sender, SelectionChangedEventArgs e)
{
    // TODO: Add event handler implementation here.
}
}
```

You will implement these handlers in a later step, so leave them empty for the time being.

The InkCanvas Control

To finish the UI of this tab, you need to place an InkCanvas control into the StackPanel so it appears below the Toolbar you just created. Unfortunately, the Visual Studio toolbox will *not* show you every possible WPF component by default. While you could simply type in the necessary XAML, you should know that you can indeed update the items to be displayed in the toolbox.

To do so, right-click anywhere in the Toolbox area and select the Choose Items menu option. After a moment or two, you will see a list of possible components to add to the toolbox. For your purposes, you are interested in adding the InkCanvas control (see Figure 27-31).

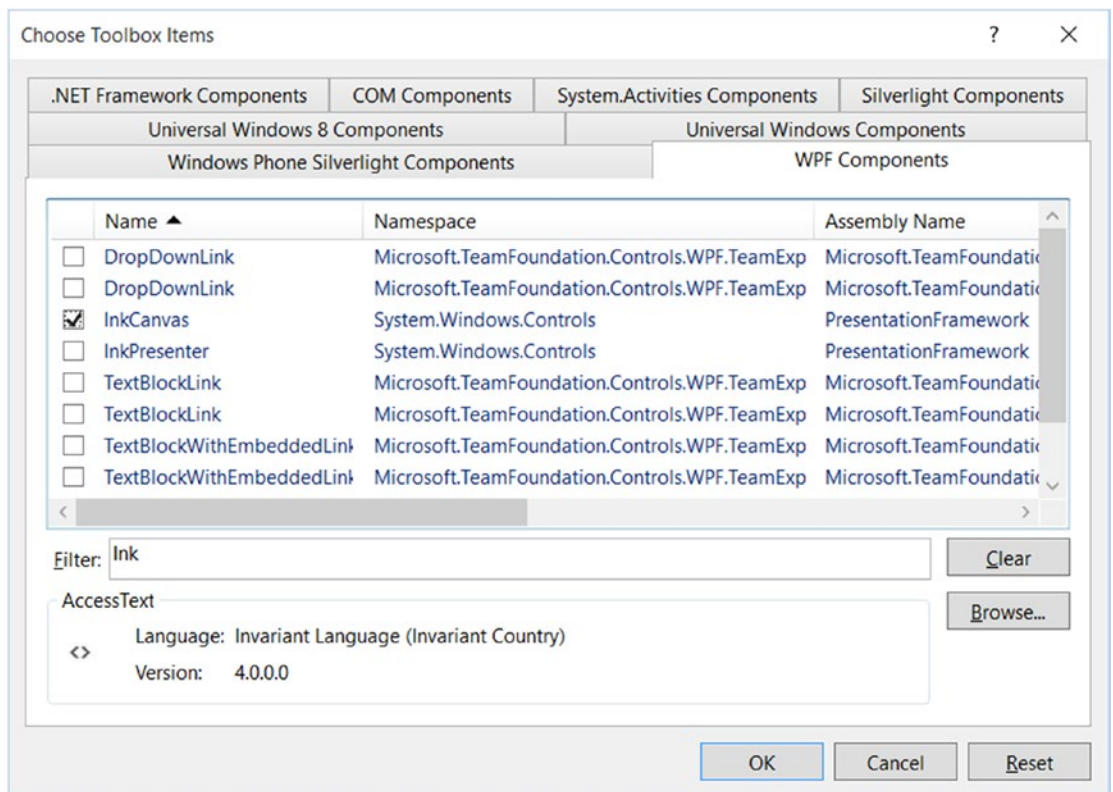

Figure 27-31. Adding new components to the Visual Studio toolbox

Select the StackPanel for the tabInk object in the Document Outline editor, and then add an InkCanvas named myInkCanvas. Resize this new control so that it takes up a majority of the tab area. Also, you might opt to use the Brushes editor to give your InkCanvas a unique background color (you'll learn much more about the Brushes editor in the next chapter). After you do this, run your program by pressing the F5 key. You will see that the canvas is already able to draw data when you click-and-drag the left-mouse button (see Figure 27-32).

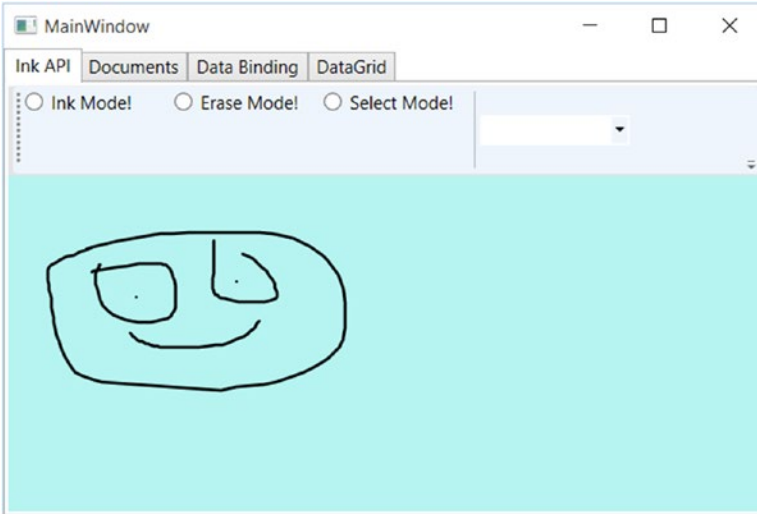

Figure 27-32. The InkCanvas in action

The InkCanvas does more than draw mouse (or stylus) strokes; it also supports a number of unique editing modes, controlled by the `EditMode` property. You can assign this property any value from the related `InkCanvasEditMode` enumeration. For this example, you are interested in Ink mode, which is the default option you just witnessed; Select mode, which allows the user to select a region with the mouse to move or resize; and `EraseByStroke`, which will delete the previous mouse stroke.

■ **Note** A *stroke* is the rendering that takes place during a single mouse down/mouse up operation. The InkCanvas stores all strokes in a `StrokeCollection` object, which you can access using the `Strokes` property.

Update your `RadioButtonClicked()` handler with the following logic, which places the InkCanvas in the correct mode, based on the selected `RadioButton`:

```
private void RadioButtonClicked(object sender,RoutedEventArgs e)
{
    // Based on which button sent the event, place the InkCanvas in a unique
    // mode of operation.
    switch((sender as RadioButton)?.Content.ToString())
    {
        // These strings must be the same as the Content values for each
        // RadioButton.
```



```

case "Ink Mode!":
    this.myInkCanvas.EditingMode = InkCanvasEditingMode.Ink;
    break;

case "Erase Mode!":
    this.myInkCanvas.EditingMode = InkCanvasEditingMode.EraseByStroke;
    break;

case "Select Mode!":
    this.myInkCanvas.EditingMode = InkCanvasEditingMode.Select;
    break;
}
}

```

Also, set the mode to Ink by default in the window's constructor. And while you are at it, set a default selection for the ComboBox (more details on this control in the next section), as follows:

```

public MainWindow()
{
    this.InitializeComponent();

    // Be in Ink mode by default.
    this.myInkCanvas.EditingMode = InkCanvasEditingMode.Ink;
    this.inkRadio.IsChecked = true;
    this.comboColors.SelectedIndex = 0;
}

```

Now run your program again by pressing F5. Enter Ink mode and draw some data. Next, enter Erase mode and remove the previous mouse stroke you entered (you'll notice the mouse icon automatically looks like an eraser). Finally, enter Select mode and select some strokes by using the mouse as a lasso.

After you circle the item, you can move it around the canvas and resize its dimensions. Figure 27-33 shows your edit modes at work.

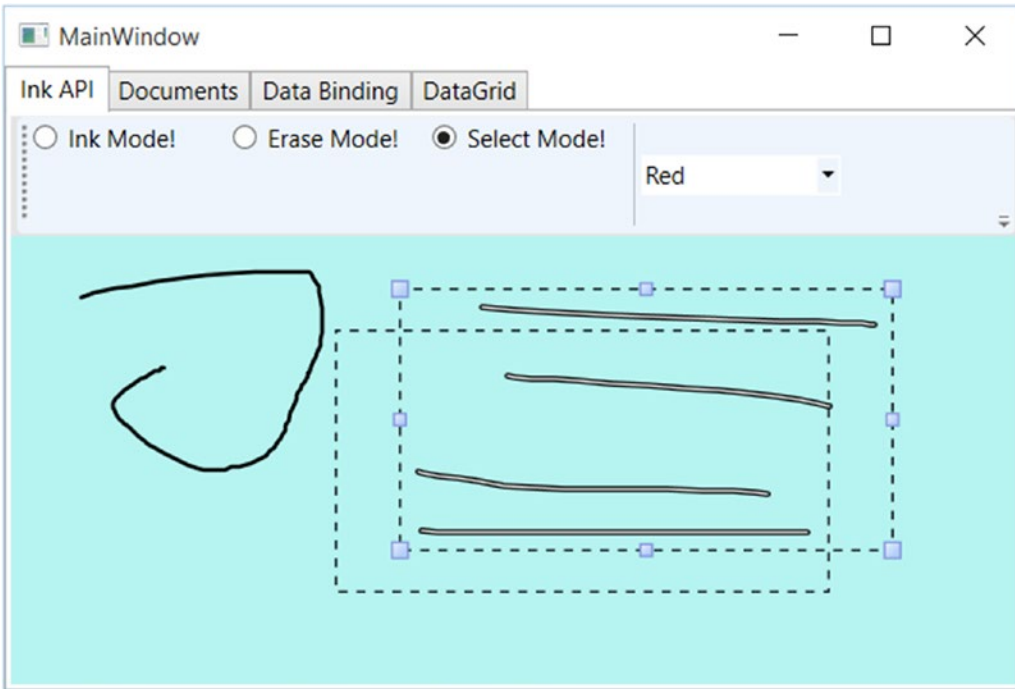

Figure 27-33. *The InkCanvas in action, with edit modes!*

The ComboBox Control

After you populate a ComboBox control (or a ListBox), you have three ways to determine the selected item. First, if you want to find the numerical index of the item selected, you can use the `SelectedIndex` property (which is zero-based; a value of -1 represents no selection). Second, if you want to obtain the object within the list that has been selected, the `SelectedItem` property fits the bill. Third, the `SelectedItem` allows you to obtain the value of the selected object (typically obtained using a call to `ToString()`).

You need to add the last bit of code for this tab to change the color of the strokes entered on the InkCanvas. The `DefaultDrawingAttributes` property of InkCanvas returns a `DrawingAttributes` object that allows you to configure numerous aspect of the pen nib, including its size and color (among other settings). Update your C# code with this implementation of the `ColorChanged()` method:

```
private void ColorChanged(object sender, SelectionChangedEventArgs e)
{
    // Get the selected value in the combo box.
    string colorToUse =
        (this.comboColors.SelectedItem as ComboBoxItem)?.Content.ToString();

    // Change the color used to render the strokes.
    this.myInkCanvas.DefaultDrawingAttributes.Color =
        (Color)ColorConverter.ConvertFromString(colorToUse);
}
```

Now recall that the `ComboBox` has a collection of `ComboBoxItems`. If you view the generated XAML, you'll see the following definition:

```
<ComboBox x:Name="comboColors" Width="100" SelectionChanged="ColorChanged">
  <ComboBoxItem Content="Red"/>
  <ComboBoxItem Content="Green"/>
  <ComboBoxItem Content="Blue"/>
</ComboBox>
```

When you call `SelectedItem`, you grab the selected `ComboBoxItem`, which is stored as a general `Object`. After you cast the `Object` as a `ComboBoxItem`, you pluck out the value of the `Content`, which will be the string `Red`, `Green`, or `Blue`. This string is then converted to a `Color` object using the handy `ColorConverter` utility class. Now run your program again. You should be able to change between colors as you render your image.

Note that the `ComboBox` and `ListBox` controls can contain complex content as well, rather than a list of text data. You can get a sense of some of the things that are possible by opening the XAML editor for your window and changing the definition of your `ComboBox` so it contains a set of `<StackPanel>` elements, each of which contains an `<Ellipse>` and a `<Label>` (notice that the `Width` of the `ComboBox` is 200).

```
<ComboBox x:Name="comboColors" Width="200" SelectionChanged="ColorChanged">
  <StackPanel Orientation="Horizontal" Tag="Red">
    <Ellipse Fill="Red" Height="50" Width="50"/>
    <Label FontSize="20" HorizontalAlignment="Center"
      VerticalAlignment="Center" Content="Red"/>
  </StackPanel>

  <StackPanel Orientation="Horizontal" Tag="Green">
    <Ellipse Fill="Green" Height="50" Width="50"/>
    <Label FontSize="20" HorizontalAlignment="Center"
      VerticalAlignment="Center" Content="Green"/>
  </StackPanel>

  <StackPanel Orientation="Horizontal" Tag="Blue">
    <Ellipse Fill="Blue" Height="50" Width="50"/>
    <Label FontSize="20" HorizontalAlignment="Center"
      VerticalAlignment="Center" Content="Blue"/>
  </StackPanel>
</ComboBox>
```

Notice that each `StackPanel` assigns a value to its `Tag` property, which is a simple, fast, and convenient way to discover which stack of items has been selected by the user (there are better ways to do this, but this will do for now). With this adjustment, you need to change the implementation of your `ColorChanged()` method, like this:

```
private void ColorChanged(object sender, SelectionChangedEventArgs e)
{
  // Get the Tag of the selected StackPanel.
  string colorToUse = (this.comboColors.SelectedItem
    as StackPanel).Tag.ToString();
  ...
}
```

Now run your program again and take note of your unique `ComboBox` (see Figure 27-34).

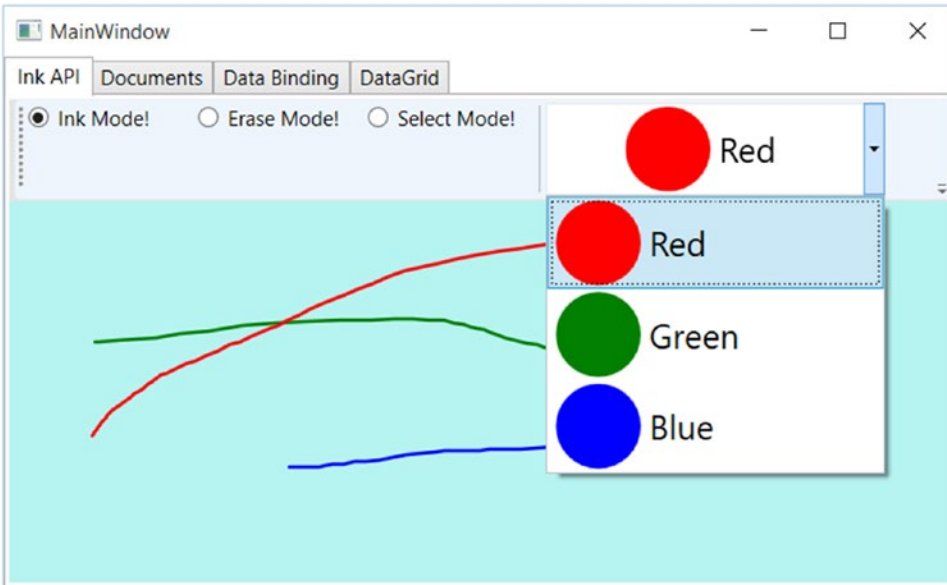

Figure 27-34. A custom ComboBox, thanks to the WPF content model

Saving, Loading, and Clearing InkCanvas Data

The last part of this tab will enable you to save and load your canvas data, as well as clear it of all content. At this point in the chapter, you might feel a bit more comfortable designing a UI, so the instructions will be short and sweet.

Begin by importing the `System.IO` and `System.Windows.Ink` namespaces to your code file. Now add three more `Button` controls to your `ToolBar` named `btnSave`, `btnLoad`, and `btnClear`. Next, handle the `Click` event for each control, then implement the handlers, like this:

```
private void SaveData(object sender, RoutedEventArgs e)
{
    // Save all data on the InkCanvas to a local file.
    using (FileStream fs = new FileStream("StrokeData.bin", FileMode.Create))
    {
        this.myInkCanvas.Strokes.Save(fs);
        fs.Close();
    }
}

private void LoadData(object sender, RoutedEventArgs e)
{
    // Fill StrokeCollection from file.
    using (FileStream fs = new FileStream("StrokeData.bin",
        FileMode.Open, FileAccess.Read))
    {
        StrokeCollection strokes = new StrokeCollection(fs);
        this.myInkCanvas.Strokes = strokes;
    }
}
```

```
private void Clear(object sender, RoutedEventArgs e)
{
    // Clear all strokes.
    this.myInkCanvas.Strokes.Clear();
}
```

You should now be able to save your data to a file, load it from the file, and clear the InkCanvas of all data. That wraps up the first tab of the TabControl, as well as your examination of the WPF digital Ink API. To be sure, there is more to say about this technology; however, you should be in a good position to dig into the topic further if that interests you. Next, you will learn how to use the WPF Documents API.

Introducing the Documents API

WPF ships with many controls that allow you to capture or display simple blurbs of textual data, including Label, TextBox, TextBlock, and PasswordBox. These controls are useful, but some WPF applications require the use of sophisticated, highly formatted text data, similar to what you might find in an Adobe PDF file. The Documents API of WPF provides such functionality; however, it uses the XML Paper Specification (XPS) format rather than the PDF file format.

You can use the Documents API to construct a print-ready document by leveraging several classes from the System.Windows.Documents namespace. Here you will find a number of types that represent pieces of a rich XPS document, such as List, Paragraph, Section, Table, LineBreak, Figure, Floater, and Span.

Block Elements and Inline Elements

Formally speaking, the items you add to an XPS document belong to one of two broad categories: *block elements* and *inline elements*. This first category, block elements, consists of classes that extend the System.Windows.Documents.Block base class. Examples of block elements include List, Paragraph, BlockUIContainer, Section, and Table. You use classes from this category to group together other content (e.g., a list containing paragraph data, and a paragraph containing subparagraphs for different text formatting).

The second category, inline elements, consists of classes that extend the System.Windows.Documents.Inline base class. You nest inline elements within another block item (or possibly within another inline element inside a block element). Some common inline elements include Run, Span, LineBreak, Figure, and Floater.

These classes possess names that you might encounter when building a rich document with a professional editor. As with any other WPF control, you can configure these classes in XAML or through code. Therefore, you can either declare an empty <Paragraph> element that is populated at runtime (you'll see how to do such tasks in this example) or define a populated <Paragraph> element with static text.

Document Layout Managers

You might think you can simply place inline and block elements directly into a panel container such as a Grid; however, you need to wrap them in a <FlowDocument> element or a <FixedDocument> element.

It is ideal to place items in a FlowDocument when you want to let your end user change the way the data is presented on the computer screen. The user can do this by zooming text or changing how the data is presented (e.g., a single long page or a pair of columns). You're better off using FixedDocument for true print-ready (WYSIWYG), unchangeable document data.

For this example, you will only concern yourself with the FlowDocument container. After you insert inline and block items to your FlowDocument, the FlowDocument object is placed in one of four specialized XPS-aware layout managers, listed in Table 27-4.

Table 27-4. XPS Control Layout Managers

| Panel Control | Meaning in Life |
|--------------------------|---|
| FlowDocumentReader | Displays data in a FlowDocument and adds support for zooming, searching, and content layout in various forms. |
| FlowDocumentScrollViewer | Displays data in a FlowDocument; however, the data is presented as a single document viewed with scrollbars. This container does not support zooming, searching, or alternative layout modes. |
| RichTextBox | Displays data in a FlowDocument and adds support for user editing. |
| FlowDocumentPageViewer | Displays the document page by page, one page at a time. Data can also be zoomed, but not searched. |

The most feature-rich way to display a FlowDocument is to wrap it within a FlowDocumentReader manager. When you do this, the user can alter the layout, search for words in the document, and zoom in on the data using the provided UI. The one limitation of this container (as well as of FlowDocumentScrollViewer and FlowDocumentPageViewer) is that the content you display with it is read-only. However, if you do want to allow the end user to enter new information to the FlowDocument, you can wrap it in a RichTextBox control.

Building the Documents Tab

Click the Documents tab of your TabItem and use the designer to open this control for editing. You should already have a default <Grid> control as the direct child of the TabItem control; however, change it to a StackPanel here using the Document Outline window. This tab will be used to display a FlowDocument that allows the user to highlight selected text, as well as add annotations using the Sticky Notes API.

Begin by defining the following Toolbar control, which has three simple (and unnamed!) Button controls. You will be rigging up a few new commands to these controls later on, so you do not need to refer to them in code (feel free to enter the XAML directly, or use the IDE if you prefer).

```
<TabItem x:Name="tabDocuments" Header="Documents" VerticalAlignment="Bottom"
    Height="20">
  <StackPanel>
    <ToolBar>
      <Button BorderBrush="Green" Content="Add Sticky Note"/>
      <Button BorderBrush="Green" Content="Delete Sticky Notes"/>
      <Button BorderBrush="Green" Content="Highlight Text"/>
    </ToolBar>
  </StackPanel>
</TabItem>
```

If you want, you can update the toolbox of Visual Studio to include a FlowDocumentReader control (using the same technique as you did when adding the InkCanvas), or update the current TabItem manually using the XAML editor.

In either case, add a `FlowDocumentReader` into your `StackPanel`, rename it to `myDocumentReader`, and stretch it out over the surface of your `StackPanel`. To this new component, add an empty `<FlowDocument>`.

```
<FlowDocumentReader x:Name="myDocumentReader" Height="269.4">
  <FlowDocument/>
</FlowDocumentReader>
```

At this point, you can add document classes (e.g., `List`, `Paragraph`, `Section`, `Table`, `LineBreak`, `Figure`, `Floater`, and `Span`) to the `<FlowDocument>` element. Here is one possible way to configure the `FlowDocument`:

```
<FlowDocumentReader x:Name="myDocumentReader" Height="269.4">
  <FlowDocument>
    <Section Foreground = "Yellow" Background = "Black">
      <Paragraph FontSize = "20">
        Here are some fun facts about the WPF Documents API!
      </Paragraph>
    </Section>
  </List/>
</FlowDocument>
</FlowDocumentReader>
```

If you run your program now (hit the F5 key), you should already be able to zoom your document (using the lower-right slider bar), search for a keyword (using the lower-left search editor), and display the data in one of three manners (using the layout buttons).

Before moving to the next step, you might want to edit your XAML to use a different `FlowDocument` container, such as the `FlowDocumentScrollViewer` or a `RichTextBox`, rather than the `FlowDocumentReader`. After you have done this, run the application again and notice the different ways the document data is handled. Be sure to roll back to the `FlowDocumentReader` type when you finish this task.

Populating a FlowDocument Using Code

Now, let's build the `List` block and the remaining `Paragraph` block in code. This is important because you might need to populate a `FlowDocument` based on user input, external files, database information, or what have you. Before you do so, use the XAML editor to give the `List` and `Paragraph` elements proper names, so you can access them in code.

```
<List x:Name="listOfFunFacts"/>
<Paragraph x:Name="paraBodyText"/>
```

In your code file, define a new private method named `PopulateDocument()`. This method first adds a set of new `ListItems` to the `List`, each of which has a `Paragraph` with a single `Run`. Also, your helper method dynamically builds a formatted paragraph using three separate `Run` objects, as in the following example:

```
private void PopulateDocument()
{
  // Add some data to the List item.
  this.listOfFunFacts.FontSize = 14;
  this.listOfFunFacts.MarkerStyle = TextMarkerStyle.Circle;
  this.listOfFunFacts.ListItems.Add(new ListItem( new
    Paragraph(new Run("Fixed documents are for WYSIWYG print ready docs!"))));
}
```

```

this.listOfFunFacts.ListItems.Add(new ListItem(
    new Paragraph(new Run("The API supports tables and embedded figures!"))));
this.listOfFunFacts.ListItems.Add(new ListItem(
    new Paragraph(new Run("Flow documents are read only!"))));
this.listOfFunFacts.ListItems.Add(new ListItem(new Paragraph(new Run
    ("BlockUIContainer allows you to embed WPF controls in the document!")
    )));

// Now add some data to the Paragraph.
// First part of sentence.
Run prefix = new Run("This paragraph was generated ");

// Middle of paragraph.
Bold b = new Bold();
Run infix = new Run("dynamically");
infix.Foreground = Brushes.Red;
infix.FontSize = 30;
b.Inlines.Add(infix);

// Last part of paragraph.
Run suffix = new Run(" at runtime!");

// Now add each piece to the collection of inline elements
// of the Paragraph.
this.paraBodyText.Inlines.Add(prefix);
this.paraBodyText.Inlines.Add(infix);
this.paraBodyText.Inlines.Add(suffix);
}

```

Make sure you call this method from your window's constructor. After you do this, you can run the application and see your new, dynamically generated document content, shown in Figure 27-35.

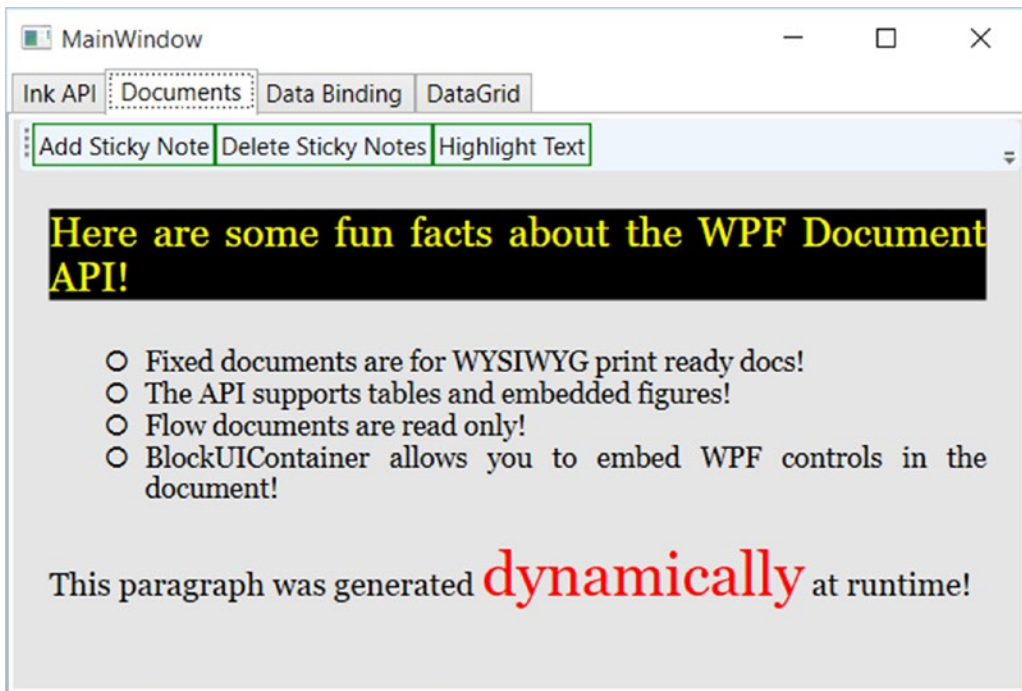

Figure 27-35. The document reader control

Enabling Annotations and Sticky Notes

So far, so good. You can now build a document with interesting data using XAML and C# code; however, you still need to address the three buttons on your toolbar for the Documents tab. WPF ships with a set of commands that are used specifically with the Documents API. You can use these commands to allow the user to select a part of a document for highlighting or to add sticky note annotations. Best of all, you can add all of this with a few lines of code (and a tad of markup).

You can find the command objects for the Documents API bundled in the `System.Windows.Annotations` namespace of `PresentationFramework.dll`. Thus, you need to define a custom XML namespace in the opening element of the `<Window>` to use such objects in XAML (notice that the tag prefix is `a`), like so:

```
<Window
...
  xmlns:a=
    "clr-namespace:System.Windows.Annotations;assembly=PresentationFramework"
  x:Class="WpfControlsAndAPIs.MainWindow"
  x:Name="Window"
  Title="MainWindow"
  Width="856" Height="383" mc:Ignorable="d"
    WindowStartupLocation="CenterScreen" >
...
</Window>
```

Now update your three <Button> definitions to set the Command property to three of the supplied annotation commands, as follows:

```
<ToolBar>
  <Button BorderBrush="Green" Content="Add Sticky Note"
          Command="a:AnnotationService.CreateTextStickyNoteCommand"/>
  <Button BorderBrush="Green" Content="Delete Sticky Notes"
          Command="a:AnnotationService.DeleteStickyNotesCommand"/>
  <Button BorderBrush="Green" Content="Highlight Text"
          Command="a:AnnotationService.CreateHighlightCommand"/>
</ToolBar>
```

The last thing you need to do is to enable annotation services for the FlowDocumentReader object, which you named myDocumentReader. Add another private method in your class named EnableAnnotations(), which is called from the constructor of the window. Now import the following namespaces:

```
using System.Windows.Annotations;
using System.Windows.Annotations.Storage;
```

Next, implement this method:

```
private void EnableAnnotations()
{
  // Create the AnnotationService object that works
  // with our FlowDocumentReader.
  AnnotationService anoService = new AnnotationService(myDocumentReader);

  // Create a MemoryStream that will hold the annotations.
  MemoryStream anoStream = new MemoryStream();

  // Now, create an XML-based store based on the MemoryStream.
  // You could use this object to programmatically add, delete,
  // or find annotations.
  AnnotationStore store = new XmlStreamStore(anoStream);

  // Enable the annotation services.
  anoService.Enable(store);
}
```

The AnnotationService class allows a given document layout manger to opt in to annotation support. Before you call the Enable() method of this object, you need to provide a location for the object to store annotation data, which in this example is a chunk of memory represented by a MemoryStream object. Notice that you connect the AnnotationService object with the Stream using the AnnotationStore.

Now, run your application. When you select some text, you can click the Add Sticky Note button and type in some information. Also, when you select some text, you can highlight data (the color is yellow by default). Finally, you can delete created notes by selecting them and clicking the Delete Sticky Note button. Figure 27-36 shows a test run.

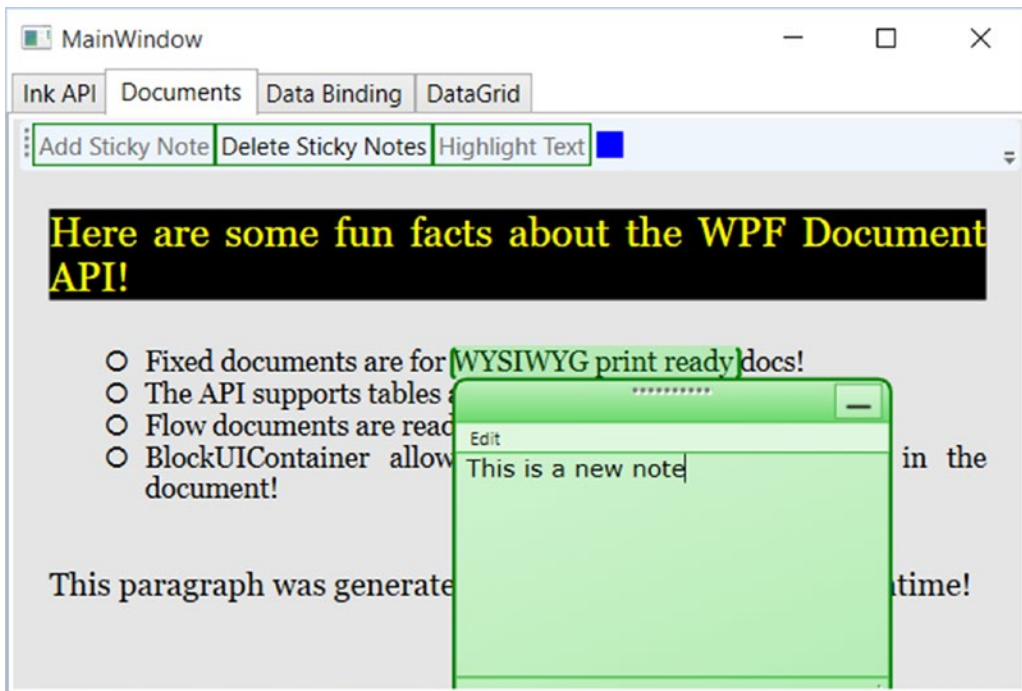

Figure 27-36. Sticky notes!

Saving and Loading a Flow Document

Let's wrap up this look at the Documents API by looking at how simple it is to save a document out to a file and to read a document in from a file. Recall that, unless you wrap your `FlowDocument` object in a `RichTextBox`, the end user cannot edit the document; however, part of the document was created dynamically at runtime, so you might like to save it for later use. The ability to load an XPS-style document could also be useful in many WPF applications because you might want to define a blank document and load it all on the fly.

This next snippet assumes you will add two new `Buttons` to the toolbar of the Documents tab, which you declare like this (note that you did not handle any events in your markup):

```
<Button x:Name="btnSaveDoc" HorizontalAlignment="Stretch"
        VerticalAlignment="Stretch" Width="75" Content="Save Doc"/>
<Button x:Name="btnLoadDoc" HorizontalAlignment="Stretch"
        VerticalAlignment="Stretch" Width="75" Content="Load Doc"/>
```

Now, in the constructor of your window, author the following lambda expressions to save and load the `FlowDocument` data (you'll need to import the `System.Windows.Markup` namespace to gain access to the `XamlReader` and `XamlWriter` classes):

```
public MainWindow()
{
    ...
    // Rig up some Click handlers for the save/load of the flow doc.
    btnSaveDoc.Click += (o, s) =>
    {
        using(FileStream fStream = File.Open(
            "documentData.xaml", FileMode.Create))
        {
            XamlWriter.Save(this.myDocumentReader.Document, fStream);
        }
    };

    btnLoadDoc.Click += (o, s) =>
    {
        using(FileStream fStream = File.Open("documentData.xaml", FileMode.Open))
        {
            try
            {
                FlowDocument doc = XamlReader.Load(fStream) as FlowDocument;
                this.myDocumentReader.Document = doc;
            }
            catch(Exception ex) {MessageBox.Show(ex.Message, "Error Loading Doc!");}
        }
    };
}
```

That is all you need to do to save the document (note that you did not save any annotations; however, you can also accomplish that using annotation services). If you click your Save button, you will see a new `*.xaml` file in your `\bin\Debug` folder. This file contains your document data.

That wraps up your look at the WPF Documents API. To be sure, there is more to this API than you have seen here; but at this point, you know a good deal about the basics. To wrap up this chapter, you will look at a handful of data-binding topics and complete the current application.

Introducing the WPF Data-Binding Model

Controls are often the target of various data-binding operations. Simply put, *data binding* is the act of connecting control properties to data values that might change over the course of your application's lifetime. Doing so lets a user interface element display the state of a variable in your code. For example, you might use data binding to accomplish the following:

- Check a `CheckBox` control based on a Boolean property of a given object.
- Display data in `DataGrid` objects from a relational database table.
- Connect a `Label` to an integer that represents the number of files in a folder.

When you use the intrinsic WPF data-binding engine, you must be aware of the distinction between the *source* and the *destination* of the binding operation. As you might expect, the source of a data-binding operation is the data itself (e.g., a Boolean property or relational data), while the destination (target) is the UI control property that uses the data content (e.g., a property on a CheckBox or TextBox control).

Truth be told, using the WPF data-binding infrastructure is always optional. If you were to roll your own data-binding logic, the connection between a source and destination typically would involve handling various events and authoring procedural code to connect the source and destination. For example, if you had a ScrollBar on a window that needed to display its value on a Label type, you might handle the ScrollBar's ValueChanged event and update the Label's content accordingly.

However, you can use WPF data binding to connect the source and destination directly in XAML (or use C# code in your code file) without the need to handle various events or hard-code the connections between the source and destination. Also, based on how you set up your data-binding logic, you can ensure that the source and destination stay in sync if either of their values changes.

Building the Data Binding Tab

Using the Document Outline editor, change the Grid of your third tab to a StackPanel. Now, use the Toolbox and Properties editor of Visual Studio to build the following initial layout:

```
<TabItem x:Name="tabDataBinding" Header="Data Binding">
  <StackPanel Width="250">
    <Label Content="Move the scroll bar to see the current value"/>

    <!-- The scrollbar's value is the source of this data bind. -->
    <ScrollBar x:Name="mySB" Orientation="Horizontal" Height="30"
      Minimum = "1" Maximum = "100" LargeChange="1" SmallChange="1"/>

    <!-- The label's content will be bound to the scroll bar! -->
    <Label x:Name="labelSBThumb" Height="30" BorderBrush="Blue"
      BorderThickness="2" Content = "0"/>
  </StackPanel>
</TabItem>
```

Notice that the <ScrollBar> object (named mySB here) has been configured with a range between 1 and 100. The goal is to ensure that, as you reposition the thumb of the scrollbar (or click the left or right arrow), the Label will automatically update with the current value. Currently, the Content property of the Label control is set to the value "0"; however, you will change this via a data-binding operation.

Establishing Data Bindings Using Visual Studio

The glue that makes it possible to define a binding in XAML is the {Binding} markup extension. If you would like to establish a binding between controls using Visual Studio, you can do so easily. For this example, locate the Content property of the labelSBThumb Label object (in the Common area of the Properties window) and click the small square next to the property to open a context menu. From here, select Create Data Binding (see Figure 27-37).

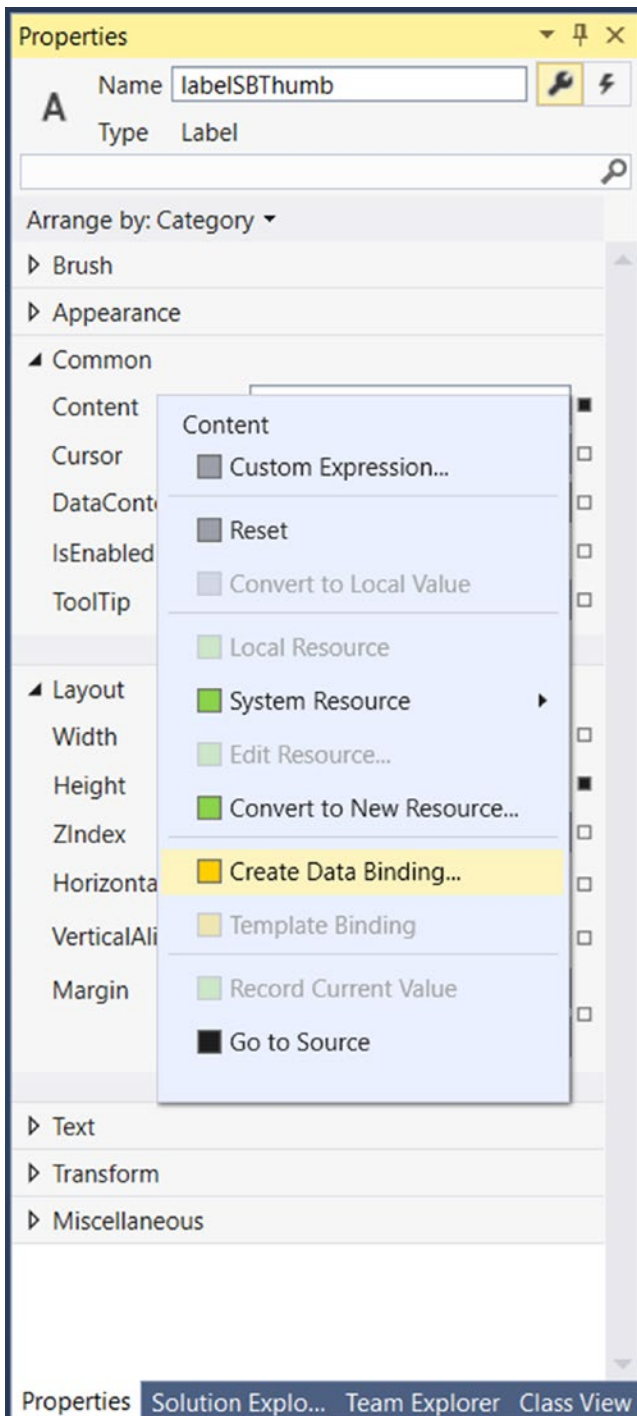

Figure 27-37. Configuring a data-binding operation

Next, select the `ElementName` option from the Binding Type drop-down list, which will give you a list of all items in your XAML file that can be selected as the source of the data-binding operation. In the Element Name tree control, find your `ScrollBar` object (named `mySB`). In the Path tree, find the `Value` property (see Figure 27-38). Click the OK button once you do this.

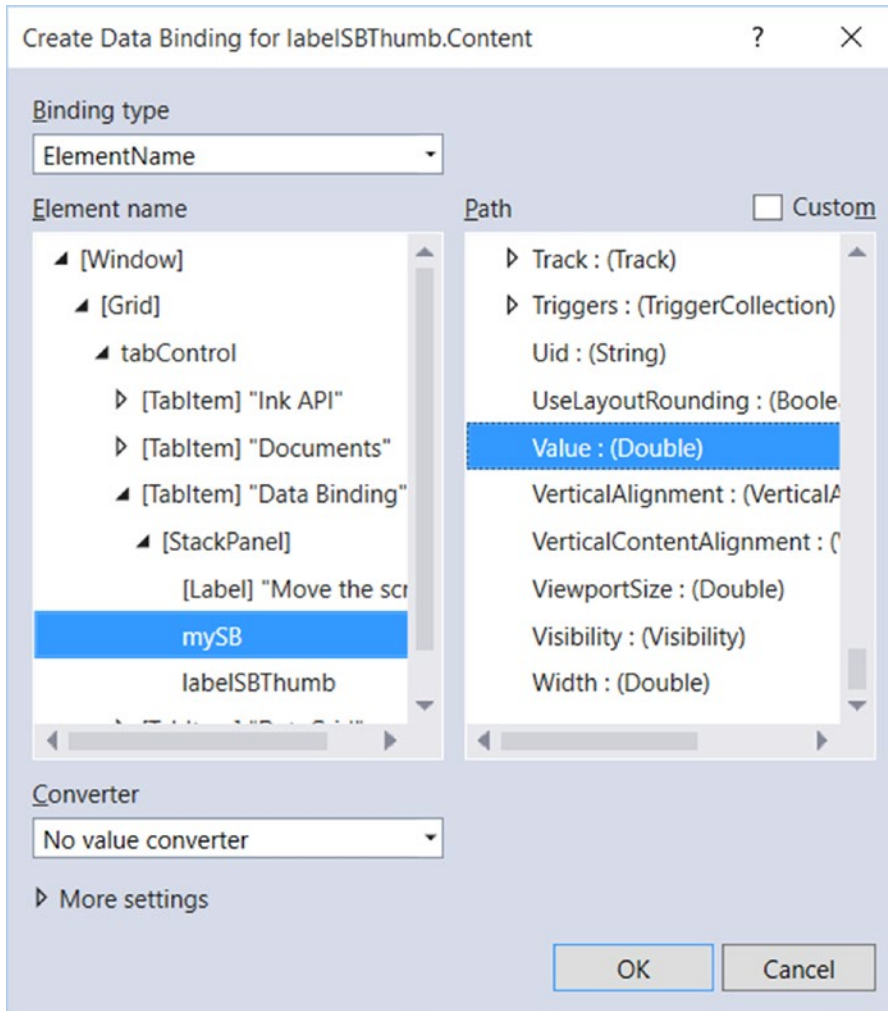

Figure 27-38. Selecting the source object and the property on the object

If you run your program again, you will find that the content of the label updates based on the scrollbar value as you move the thumb! Now look at the following XAML the data-binding tool generated on your behalf:

```
<Label x:Name="labelSBThumb" Height="30" BorderBrush="Blue" BorderThickness="2"
      Content = "{Binding Value, ElementName=mySB}"/>
```

Note the value assigned to the Label's Content property. Here, the ElementName value represents the source of the data-binding operation (the ScrollBar object), while the first item after the Binding keyword (Value) represents (in this case) the property of the element to obtain.

If you have worked with WPF data binding previously, you might expect to see the use of the Path token to set the property to observe on the object. For example, the following markup would also update the Label correctly:

```
<Label x:Name="labelSBThumb" Height="30" BorderBrush="Blue"
      BorderThickness="2" Content = "{Binding Path=Value, ElementName=mySB }"/>
```

By default, the Path= aspect of the data-binding operation is omitted unless the property is a subproperty of another object (e.g., myObject.MyProperty.Object2.Property2).

The DataContext Property

You can define a data-binding operation in XAML using an alternative format, where it is possible to break out the values specified by the {Binding} markup extension by explicitly setting the DataContext property to the source of the binding operation, as follows:

```
<!-- Breaking object/value apart via DataContext -->
<Label x:Name="labelSBThumb" Height="30" BorderBrush="Blue"
      BorderThickness="2"
      DataContext = "{Binding ElementName=mySB}"
      Content = "{Binding Path=Value}" />
```

In the current example, the output would be identical if you were to modify the markup in this way. Given this, you might wonder when you would want to set the DataContext property explicitly. Doing so can be helpful because subelements can inherit its value in a tree of markup.

In this way, you can easily set the same data source to a family of controls, rather than having to repeat a bunch of redundant "{Binding ElementName=X, Path=Y}" XAML values to multiple controls. For example, assume you have added the following new Button to the <StackPanel> of this tab (you'll see why it is so large in just a moment):

```
<Button Content="Click" Height="140"/>
```

You could use Visual Studio to generate data bindings for multiple controls, but instead try entering the modified markup manually using the XAML editor, like so:

```
<!-- Note the StackPanel sets the DataContext property. -->
<StackPanel Width="250" DataContext = "{Binding ElementName=mySB}">
  <Label Content="Move the scroll bar to see the current value"/>

  <ScrollBar Orientation="Horizontal" Height="30" Name="mySB"
    Maximum = "100" LargeChange="1" SmallChange="1"/>

  <!-- Now both UI elements use the scrollbar's value in unique ways. -->
  <Label x:Name="labelSBThumb" Height="30" BorderBrush="Blue" BorderThickness="2"
    Content = "{Binding Path=Value}"/>

  <Button Content="Click" Height="200"
    FontSize = "{Binding Path=Value}"/>
</StackPanel>
```

Here, you set the `DataContext` property on the `<StackPanel>` directly. Therefore, as you move the thumb, you see not only the current value on the `Label`, but also see the font size of the `Button` grow and shrink accordingly, based on the same value (see Figure 27-39 shows one possible output).

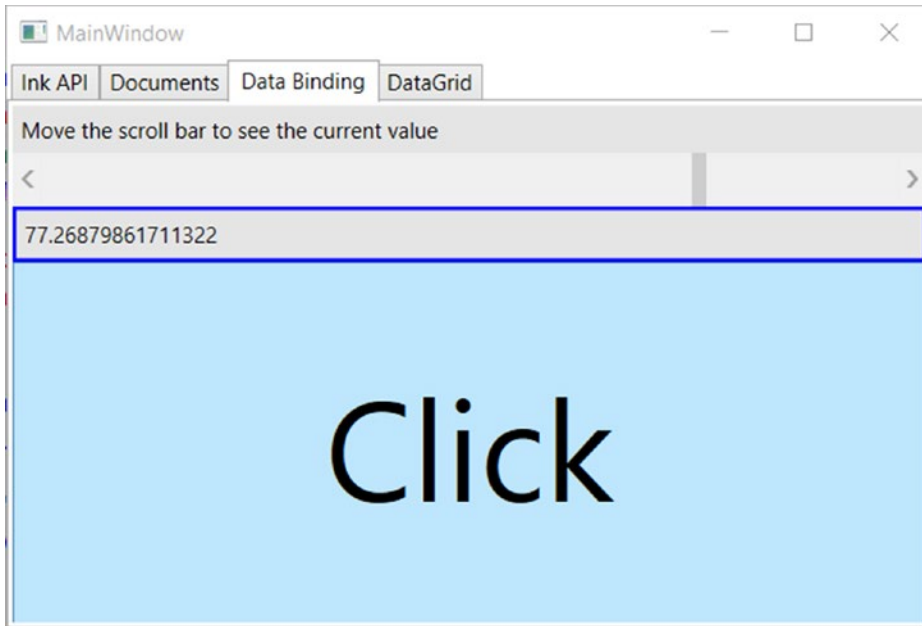

Figure 27-39. Binding the `ScrollBar` value to a `Label` and a `Button`

Data Conversion Using `IValueConverter`

The `ScrollBar` type uses a `double` to represent the value of the thumb, rather than an expected whole number (e.g., an integer). Therefore, as you drag the thumb, you will find various floating-point numbers displayed within the `Label` (e.g., 61.0576923076923). The end user would find this rather unintuitive because he is most likely expecting to see whole numbers (e.g., 61, 62, and 63).

If you want to convert the value of a data-binding operation into an alternative format, you could create a custom class that implements the `IValueConverter` interface of the `System.Windows.Data` namespace. This interface defines two members that allow you to perform the conversion to and from the target and destination (in the case of a two-way data binding). After you define this class, you can use it to qualify further the processing of your data-binding operation.

Assuming that you want to display whole numbers within the Label control, you can build the following custom conversion class. Activate the Project Add Class menu and insert a class named MyDoubleConverter. Next, add the following:

```
class MyDoubleConverter : IValueConverter
{
    public object Convert(object value, Type targetType, object parameter,
        System.Globalization.CultureInfo culture)
    {
        // Convert the double to an int.
        double v = (double)value;
        return (int)v;
    }

    public object ConvertBack(object value, Type targetType, object parameter,
        System.Globalization.CultureInfo culture)
    {
        // You won't worry about "two-way" bindings
        // here, so just return the value.
        return value;
    }
}
```

The Convert() method is called when the value is transferred from the source (the ScrollBar) to the destination (the Text property of the TextBox). You will receive many incoming arguments, but you only need to manipulate the incoming object for this conversion, which is the value of the current double. You can use this type to cast the type into an integer and return the new number.

The ConvertBack() method will be called when the value is passed from the destination to the source (if you have enabled a two-way binding mode). Here, you simply return the value straightaway. Doing so lets you type a floating-point value into the TextBox (e.g., 99.9) and have it automatically convert to a whole number value (e.g., 99) when the user tabs off the control. This “free” conversion happens due to the fact that the Convert() method is called again, after a call to ConvertBack(). If you were simply to return null from ConvertBack(), your binding would appear to be out of sync because the text box would still be displaying a floating-point number.

Establishing Data Bindings in Code

With this class in place, you are ready to register your custom converter with any control that wishes to use it. You could accomplish this exclusively in XAML; however, to do so, you would need to define some custom object resources, which you will not learn how to do until the next chapter. For now, you can register your data conversion class in code. Begin by cleaning up the current definition of the <Label> control in your data binding tab, so that it no longer uses the {Binding} markup extension.

```
<Label x:Name="labelSBThumb" Height="30" BorderBrush="Blue"
    BorderThickness="2" Content = "0"/>
```

In your window's constructor, call a new private helper function called `SetBindings()`. In this method, add the following code (and make sure to call it from the constructor):

```
private void SetBindings()
{
    // Create a Binding object.
    Binding b = new Binding();

    // Register the converter, source, and path.
    b.Converter = new MyDoubleConverter();
    b.Source = this.mySB;
    b.Path = new PropertyPath("Value");

    // Call the SetBinding method on the Label.
    this.labelsBThumb.SetBinding(Label.ContentProperty, b);
}
```

The only part of this function that probably looks a bit off is the call to `SetBinding()`. Notice that the first parameter calls a static, read-only field of the `Label` class named `ContentProperty`. As you will learn later in this chapter, you are specifying what is known as a *dependency property*. For the time being, just know that when you set bindings in code, the first argument will nearly always require you to specify the name of the class that wants the binding (the `Label`, in this case), followed by a call to the underlying property with the `Property` suffix. In any case, running the application illustrates that the `Label` only prints out whole numbers.

Building the DataGrid Tab

The previous data-binding example illustrated how to configure two (or more) controls to participate in a data-binding operation. While this is helpful, it is also possible to bind data from XML files, database data, and in-memory objects. To complete this example, you will design the final tab of your tab control so it displays data obtained from the `Inventory` table of the `AutoLot` database.

As with the other tabs, you begin by changing the current `Grid` to a `StackPanel`. Do this by directly updating the XAML using Visual Studio. Now define a `DataGrid` control in your new `StackPanel` named `gridInventory`, like so:

```
<TabItem x:Name="tabDataGrid" Header="DataGrid">
    <StackPanel>
        <DataGrid x:Name="gridInventory" Height="288"/>
    </StackPanel>
</TabItem>
```

Use NuGet package manager to add Entity Framework to your project. Next, reference the `AutoLotDAL.dll` assembly you created in Chapter 23 (where you used the Entity Framework). This will update the `app.config` file for Entity Framework except for the connection string. This you will have to add in manually. I've listed the connection string for my machine here for your reference:

```
<connectionStrings>
    <add name="AutoLotConnection" connectionString="data source=.\SQLEXPRESS2014;initial
        catalog=AutoLot;integrated security=True;MultipleActiveResultSets=True;App=EntityFramework"
        providerName="System.Data.SqlClient" />
</connectionStrings>
```

Open the code file for your window and add a final helper function called `ConfigureGrid()`; make sure you call this from your constructor. Assuming that you did import the `AutoLotDAL` namespace, all you need to do is add a few lines of code, like so:

```
private void ConfigureGrid()
{
    using (var repo = new InventoryRepo())
    {
        // Build a LINQ query that gets back some data from the Inventory table.
        gridInventory.ItemsSource =
            repo.GetAll().Select(x=>new { x.CarId,x.Make,x.Color,x.PetName});
    }
}
```

Notice that you do not directly bind `context.Inventories` to the grid's `ItemsSource` collection; instead, you build a LINQ query that appears to ask for the same data in the entities. The reason for this approach: the `Inventory` object set also contains additional EF (Entity Framework) properties that would appear on the grid, but which don't map to the physical database.

If you were to run the project as is, you would see an extremely plain grid. To make the grid a bit less of an eyesore, use the Visual Studio Properties window to edit the `Rows` category of the `DataGrid`. At a minimum, set the `AlternationCount` property to 2 and pick a custom brush using the integrated editor for the `AlternatingRowBackground` and `RowBackground` properties. You can see the final tab for this example in Figure 27-40.

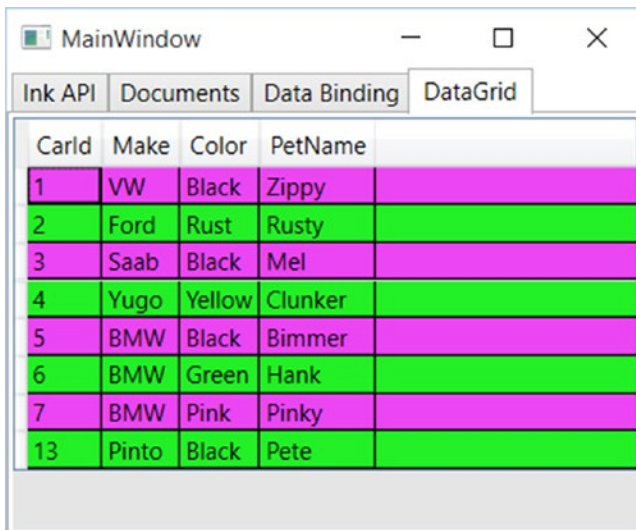

Figure 27-40. The final tab of your project

That wraps up the current example. You'll use some other controls in action during later chapters; at this point, however, you should feel comfortable with the process of building UIs in Visual Studio and manually using XAML and C# code.

■ **Source Code** You can find the `WpfControlsAndAPIs` project in the [Chapter 27](#) subdirectory.

Understanding the Role of Dependency Properties

Like any .NET API, WPF makes use of each member of the .NET type system (classes, structures, interfaces, delegates, enumerations) and each type member (properties, methods, events, constant data, read-only fields, etc.) within its implementation. However, WPF also supports a unique programming concept termed a *dependency property*.

Like a “normal” .NET property (often termed a *CLR property* in the WPF literature), dependency properties can be set declaratively using XAML or programmatically within a code file. Furthermore, dependency properties (like CLR properties) ultimately exist to encapsulate data fields of a class and can be configured as read-only, write-only, or read-write.

To make matters more interesting, in almost every case you will be blissfully unaware that you have actually set (or accessed) a dependency property as opposed to a CLR property! For example, the `Height` and `Width` properties that WPF controls inherit from `FrameworkElement`, as well as the `Content` member inherited from `ControlContent`, are all, in fact, dependency properties.

```
<!-- Set three dependency properties! -->
<Button x:Name = "btnMyButton" Height = "50" Width = "100" Content = "OK"/>
```

Given all of these similarities, why does WPF define a new term for such a familiar concept? The answer lies in how a dependency property is implemented within the class. You’ll see a coding example in just a little bit; however, from a high level, all dependency properties are created in the following manner:

- First, the class that defined a dependency property must have `DependencyObject` in its inheritance chain.
- A single dependency property is represented as a public, static, read-only field in the class of type `DependencyProperty`. By convention, this field is named by suffixing the word `Property` to the name of the CLR wrapper (see final bullet point).
- The `DependencyProperty` variable is registered via a static call to `DependencyProperty.Register()`, which typically occurs in a static constructor or inline when the variable is declared.
- Finally, the class will define a XAML-friendly CLR property, which makes calls to methods provided by `DependencyObject` to get and set the value.

Once implemented, dependency properties provide a number of powerful features that are used by various WPF technologies including data binding, animation services, styles, templates, and so forth. In a nutshell, the motivation of dependency properties is to provide a way to compute the value of a property based on the value of other inputs. Here is a list of some of these key benefits, which go well beyond those of the simple data encapsulation found with a CLR property:

- Dependency properties can inherit their values from a parent element’s XAML definition. For example, if you defined a value for the `FontSize` attribute in the opening tag of a `<Window>`, all controls in that `Window` would have the same font size by default.
- Dependency properties support the ability to have values set by elements contained within their XAML scope, such as a `Button` setting the `Dock` property of a `DockPanel` parent. (Recall from [Chapter 28](#) that *attached properties* do this very thing because attached properties are a form of dependency properties.)

- Dependency properties allow WPF to compute a value based on multiple external values, which can be very important for animation and data-binding services.
- Dependency properties provide infrastructure support for WPF triggers (also used quite often when working with animation and data binding).

Now remember, in many cases you will interact with an existing dependency property in a manner identical to a normal CLR property (thanks to the XAML wrapper). In the last section, which covered data binding, you saw that if you need to establish a data binding in code, you must call the `SetBinding()` method on the object that is the destination of the operation and specify the *dependency property* it will operate on, like so:

```
private void SetBindings()
{
    Binding b = new Binding();
    b.Converter = new MyDoubleConverter();
    b.Source = this.mySB;
    b.Path = new PropertyPath("Value");

    // Specify the dependency property!
    this.labelsBThumb.SetBinding(Label.ContentProperty, b);
}
```

You will see similar code when you examine how to start an animation in code in Chapter 29.

```
// Specify the dependency property!
rt.BeginAnimation(RotateTransform.AngleProperty, dblAnim);
```

The only time you need to build your own custom dependency property is when you are authoring a custom WPF control. For example, if you are building a `UserControl` that defines four custom properties and you want these properties to integrate well within the WPF API, you should author them using dependency property logic.

Specifically, if your properties need to be the target of a data-binding or animation operation, if the property must broadcast when it has changed, if it must be able to work as a `Setter` in a WPF style, or if it must be able to receive their values from a parent element, a normal CLR property will *not* be enough. If you were to use a normal CLR property, other programmers may indeed be able to get and set a value; however, if they attempt to use your properties within the context of a WPF service, things will not work as expected. Because you can never know how others might want to interact with the properties of your custom `UserControl` classes, you should get in the habit of *always* defining dependency properties when building custom controls.

Examining an Existing Dependency Property

Before you learn how to build a custom dependency property, let's take a look at how the `Height` property of the `FrameworkElement` class has been implemented internally. The relevant code is shown here (with my included comments):

```
// FrameworkElement is-a DependencyObject.
public class FrameworkElement : UIElement, IFrameworkInputElement,
    IInputElement, ISupportInitialize, IHaveResources, IQueryAmbient
{
    ...
```

```

// A static read-only field of type DependencyProperty.
public static readonly DependencyProperty HeightProperty;

// The DependencyProperty field is often registered
// in the static constructor of the class.
static FrameworkElement()
{
    ...
    HeightProperty = DependencyProperty.Register(
        "Height",
        typeof(double),
        typeof(FrameworkElement),
        new FrameworkPropertyMetadata((double) 1.0 / (double) 0.0,
            FrameworkPropertyMetadataOptions.AffectsMeasure,
            new PropertyChangedCallback(FrameworkElement.OnTransformDirty)),
            new ValidateValueCallback(FrameworkElement.IsWidthHeightValid));
}

// The CLR wrapper, which is implemented using
// the inherited GetValue()/SetValue() methods.
public double Height
{
    get { return (double) base.GetValue(HeightProperty); }
    set { base.SetValue(HeightProperty, value); }
}
}

```

As you can see, dependency properties require quite a bit of additional code from a normal CLR property! And in reality, a dependency can be even more complex than what you see here (thankfully, many implementations are simpler than `Height`).

First and foremost, remember that if a class wants to define a dependency property, it must have `DependencyObject` in the inheritance chain because this is the class that defines the `GetValue()` and `SetValue()` methods used in the CLR wrapper. Because `FrameworkElement` is-a `DependencyObject`, this requirement is satisfied.

Next, recall that the entity that will hold the actual value of the property (a `double` in the case of `Height`) is represented as a public, static, read-only field of type `DependencyProperty`. The name of this field should, by convention, always be named by suffixing the word `Property` to the name of the related CLR wrapper, like so:

```
public static readonly DependencyProperty HeightProperty;
```

Given that dependency properties are declared as static fields, they are typically created (and registered) within the static constructor of the class. The `DependencyProperty` object is created via a call to the static `DependencyProperty.Register()` method. This method has been overloaded many times; however, in the case of `Height`, `DependencyProperty.Register()` is invoked as follows:

```

HeightProperty = DependencyProperty.Register(
    "Height",
    typeof(double),
    typeof(FrameworkElement),
    new FrameworkPropertyMetadata((double)0.0,

```

```

FrameworkPropertyMetadataOptions.AffectsMeasure,
new PropertyChangedCallback(FrameworkElement.OnTransformDirty)),
new ValidateValueCallback(FrameworkElement.IsWidthHeightValid));

```

The first argument to `DependencyProperty.Register()` is the name of the normal CLR property on the class (`Height`, in this case), while the second argument is the type information of the underlying data type it is encapsulating (a `double`). The third argument specifies the type information of the class that this property belongs to (`FrameworkElement`, in this case). While this might seem redundant (after all, the `HeightProperty` field is already defined within the `FrameworkElement` class), this is a very clever aspect of WPF in that it allows one class to register properties on another (even if the class definition has been sealed!).

The fourth argument passed to `DependencyProperty.Register()` in this example is what really gives dependency properties their own unique flavor. Here, a `FrameworkPropertyMetadata` object is passed that describes various details regarding how WPF should handle this property with respect to callback notifications (if the property needs to notify others when the value changes) and various options (represented by the `FrameworkPropertyMetadataOptions` enum) that control what is effected by the property in question (Does it work with data binding?, Can it be inherited?, etc.). In this case, the constructor arguments of `FrameworkPropertyMetadata` break down as so:

```

new FrameworkPropertyMetadata(
    // Default value of property.
    (double)0.0,

    // Metadata options.
    FrameworkPropertyMetadataOptions.AffectsMeasure,

    // Delegate pointing to method called when property changes.
    new PropertyChangedCallback(FrameworkElement.OnTransformDirty)
)

```

Because the final argument to the `FrameworkPropertyMetadata` constructor is a delegate, note that its constructor parameter is pointing to a static method on the `FrameworkElement` class named `OnTransformDirty()`. I won't bother to show the code behind this method, but be aware that any time you are building a custom dependency property, you can specify a `PropertyChangedCallback` delegate to point to a method that will be called when your property value has been changed.

This brings me to the final parameter passed to the `DependencyProperty.Register()` method, a second delegate of type `ValidateValueCallback`, which points to a method on the `FrameworkElement` class that is called to ensure the value assigned to the property is valid.

```

new ValidateValueCallback(FrameworkElement.IsWidthHeightValid)

```

This method contains logic you might normally expect to find in the set block of a property (more information on this point in the next section).

```

private static bool IsWidthHeightValid(object value)
{
    double num = (double) value;
    return ((!DoubleUtil.IsNaN(num) && (num >= 0.0))
        && !double.IsPositiveInfinity(num));
}

```

After the `DependencyProperty` object has been registered, the final task is to wrap the field within a normal CLR property (`Height`, in this case). Notice, however, that the get and set scopes do not simply return or set a class-level double-member variable, but do so indirectly using the `GetValue()` and `SetValue()` methods from the `System.Windows.DependencyObject` base class, as follows:

```
public double Height
{
    get { return (double) base.GetValue(HeightProperty); }
    set { base.SetValue(HeightProperty, value); }
}
```

Important Notes Regarding CLR Property Wrappers

So, just to recap the story thus far, dependency properties look like normal everyday properties when you get or set their values in XAML or code, but behind the scenes they are implemented with much more elaborate coding techniques. Remember, the whole reason to go through this process is to build a custom control that has custom properties that need to integrate with WPF services that demand communication with a dependency property (e.g., animation, data binding, and styles).

Even though part of the implementation of a dependency property includes defining a CLR wrapper, *you should never put validation logic in the set block*. For that matter, the CLR wrapper of a dependency property *should never do anything other than call `GetValue()` or `SetValue()`*.

The reason is that the WPF runtime has been constructed in such a way that when you write XAML that seems to set a property, such as

```
<Button x:Name="myButton" Height="100" .../>
```

the runtime will completely bypass the set block of the `Height` property and *directly* call `SetValue()`! The reason for this odd behavior has to do with a simple optimization technique. If the WPF runtime were to call the set block of the `Height` property, it would have to perform runtime reflection to figure out where the `DependencyProperty` field (specified by the first argument to `SetValue()`) is located, reference it in memory, and so forth. The same story holds true if you were to write XAML that retrieves the value of the `Height` property—`GetValue()` would be called directly.

Since this is the case, why do you need to build this CLR wrapper at all? Well, WPF XAML does not allow you to call functions in markup, so the following markup would be an error:

```
<!-- Nope! Can't call methods in WPF XAML! -->
<Button x:Name="myButton" this.SetValue("100") .../>
```

In effect, when you set or get a value in markup using the CLR wrapper, think of it as a way to tell the WPF runtime, “Hey! Go call `GetValue()/SetValue()` for me, since I can’t directly do it in markup!” Now, what if you call the CLR wrapper in code like so:

```
Button b = new Button();
b.Height = 10;
```

In this case, if the set block of the `Height` property contained code other than a call to `SetValue()`, it *would* execute because the WPF XAML parser optimization is not involved.

The basic rule to remember is that when registering a dependency property, use a `ValidateValueCallback` delegate to point to a method that performs the data validation. This ensures that the correct behavior will occur, regardless of whether you use XAML or code to get/set a dependency property.

Building a Custom Dependency Property

If you have a slight headache at this point in the chapter, this is a perfectly normal response. Building dependency properties can take some time to get used to. However, for better or worse, it is part of the process of building many custom WPF controls, so let's take a look at how to build a dependency property.

Begin by creating a new WPF application named CustomDepPropApp. Now, using the Project menu, activate the Add User Control menu option, and create a control named ShowNumberControl.xaml (see Figure 27-41).

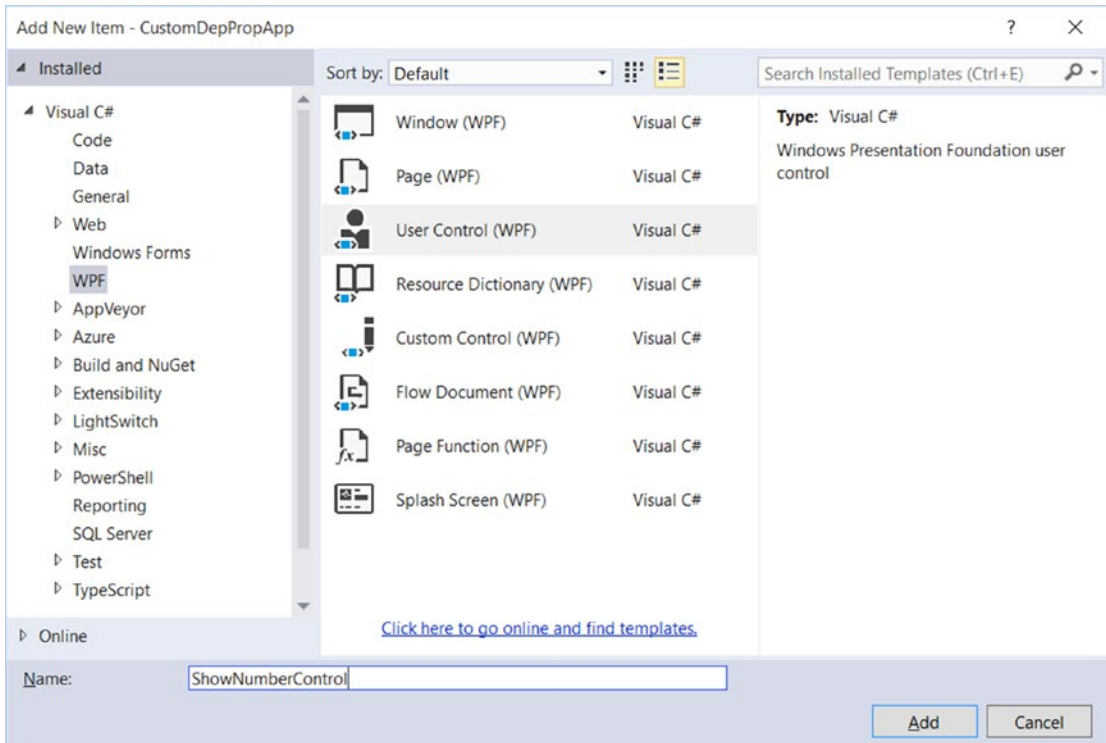

Figure 27-41. Inserting a new custom *UserControl*

■ **Note** You will learn more details about the WPF `UserControl` in Chapter 29, so just follow along as shown for now.

Just like a window, WPF `UserControl` types have a XAML file and a related code file. Update the XAML of your user control to define a single `Label` control in the `Grid`, like so:

```
<UserControl x:Class="CustomDepPropApp.ShowNumberControl"
  xmlns="http://schemas.microsoft.com/winfx/2006/xaml/presentation"
  xmlns:x="http://schemas.microsoft.com/winfx/2006/xaml"
  xmlns:mc="http://schemas.openxmlformats.org/markup-compatibility/2006"
  xmlns:d="http://schemas.microsoft.com/expression/blend/2008"
```

```

xmlns:local="clr-namespace:CustomDepPropApp"
mc:Ignorable="d"
d:DesignHeight="300" d:DesignWidth="300">
<Grid>
  <Label x>Name="numberDisplay" Height="50" Width="200" Background="LightBlue"/>
</Grid>
</UserControl>

```

In the code file of this custom control, create a normal, everyday .NET property that wraps an int and sets the Content property of the Label with the new value, as follows:

```

public partial class ShowNumberControl : UserControl
{
  public ShowNumberControl()
  {
    InitializeComponent();
  }

  // A normal, everyday .NET property.
  private int _currNumber = 0;
  public int CurrentNumber
  {
    get { return _currNumber; }
    set
    {
      _currNumber = value;
      numberDisplay.Content = CurrentNumber.ToString();
    }
  }
}

```

Now, update the XAML definition of your window to declare an instance of your custom control within a StackPanel layout manager. Because your custom control is not part of the core WPF assembly stack, you will need to define a custom XML namespace that maps to your control. Here is the required markup:

```

<Window x:Class="CustomDepPropApp.MainWindow"
  xmlns="http://schemas.microsoft.com/winfx/2006/xaml/presentation"
  xmlns:x="http://schemas.microsoft.com/winfx/2006/xaml"
  xmlns:d="http://schemas.microsoft.com/expression/blend/2008"
  xmlns:mc="http://schemas.openxmlformats.org/markup-compatibility/2006"
  xmlns:myCtrls="clr-namespace:CustomDepPropApp"
  xmlns:local="clr-namespace:CustomDepPropApp"
  mc:Ignorable="d"
  Title="Simple Dependency Property App" Height="150" Width="250"
  WindowStartupLocation="CenterScreen">
<StackPanel>
  <myCtrls:ShowNumberControl x>Name="myShowNumberCtrl" CurrentNumber="100"/>
</StackPanel>
</Window>

```

As you can see, the Visual Studio designer appears to correctly display the value that you set in the `CurrentNumber` property (see Figure 27-42).

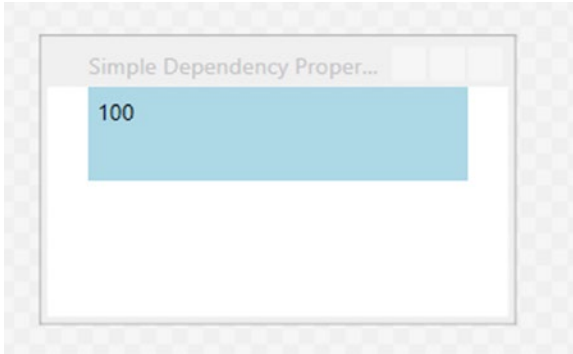

Figure 27-42. *It appears your property works as expected*

However, what if you want to apply an animation object to the `CurrentNumber` property so that the value changes from 100 to 200 over a period of 10 seconds? If you wanted to do so in markup, you might update your `<myCtrls:ShowNumberControl>` scope as so:

```
<myCtrls:ShowNumberControl x:Name="myShowNumberCtrl" CurrentNumber="100">
  <myCtrls:ShowNumberControl.Triggers>
    <EventTrigger RoutedEvent = "myCtrls:ShowNumberControl.Loaded">
      <EventTrigger.Actions>
        <BeginStoryboard>
          <Storyboard TargetProperty = "CurrentNumber">
            <Int32Animation From = "100" To = "200" Duration = "0:0:10"/>
          </Storyboard>
        </BeginStoryboard>
      </EventTrigger.Actions>
    </EventTrigger>
  </myCtrls:ShowNumberControl.Triggers>
</myCtrls:ShowNumberControl>
```

If you run your application, the animation object cannot find a proper target, so it is ignored. The reason is that the `CurrentNumber` property has not been registered as a dependency property! To fix matters, return to the code file of your custom control, and completely comment out the current property logic (including the private backing field). Now, position your mouse cursor within the scope of the class and type in the `propdp` code snippet. After you have typed `propdp`, press the Tab key twice. You will find the snippet expands to give you the basic skeleton of a dependency property as follows:

```
public int MyProperty
{
  get { return (int)GetValue(MyPropertyProperty); }
  set { SetValue(MyPropertyProperty, value); }
}
```

```
// Using a DependencyProperty as the backing store for MyProperty. This enables animation,
styling, binding, etc...
public static readonly DependencyProperty MyPropertyProperty =
    DependencyProperty.Register("MyProperty", typeof(int), typeof(ownerclass), new
PropertyMetadata(0));
```

Update the entered template to match the following code:

```
public partial class ShowNumberControl : UserControl
{
    public int CurrentNumber
    {
        get { return (int)GetValue(CurrentNumberProperty); }
        set { SetValue(CurrentNumberProperty, value); }
    }

    public static readonly DependencyProperty CurrentNumberProperty =
        DependencyProperty.Register("CurrentNumber",
            typeof(int),
            typeof(ShowNumberControl),
            new UIPropertyMetadata(0));
    ...
}
```

This is similar to what you saw in the implementation of the Height property; however, the code snippet registers the property inline rather than within a static constructor (which is fine). Also notice that a `UIPropertyMetadata` object is used to define the default value of the integer (0) rather than the more complex `FrameworkPropertyMetadata` object. This is the simplest version of `CurrentNumber` as a dependency property.

Adding a Data Validation Routine

Although you now have a dependency property named `CurrentNumber`, you still won't see your animation take hold. The next adjustment you might want to make is to specify a function to call to perform some data validation logic. For this example, assume that you need to ensure that the value of `CurrentNumber` is between 0 and 500.

To do so, add a final argument to the `DependencyProperty.Register()` method of type `ValidateValueCallback`, which points to a method named `ValidateCurrentNumber`.

`ValidateValueCallback` is a delegate that can only point to methods returning `bool` and take an object as the only argument. This object represents the new value that is being assigned. Implement `ValidateCurrentNumber` to return `true` or `false`, if the incoming value is within the expected range.

```
public static readonly DependencyProperty CurrentNumberProperty =
    DependencyProperty.Register("CurrentNumber",
        typeof(int),
        typeof(ShowNumberControl),
        new UIPropertyMetadata(100),
        new ValidateValueCallback(ValidateCurrentNumber));
```

```
public static bool ValidateCurrentNumber(object value)
{
    // Just a simple business rule. Value must be between 0 and 500.
    if (Convert.ToInt32(value) >= 0 && Convert.ToInt32(value) <= 500)
        return true;
    else
        return false;
}
```

Responding to the Property Change

Okay, so now you have a valid number, but still no animation. The final change you need to make is to specify a second argument to the constructor of `UIPropertyMetadata`, which is a `PropertyChangedCallback` object. This delegate can point to any method that takes a `DependencyObject` as the first parameter and a `DependencyPropertyChangedEventArgs` as the second. First, update your code as so:

```
// Note the second param of UIPropertyMetadata constructor.
public static readonly DependencyProperty CurrentNumberProperty =
    DependencyProperty.Register("CurrentNumber", typeof(int), typeof>ShowNumberControl',
        new UIPropertyMetadata(100,
            new PropertyChangedCallback(CurrentNumberChanged)),
        new ValidateValueCallback(ValidateCurrentNumber));
```

Within the `CurrentNumberChanged()` method, your ultimate goal is to change the `Content` of the `Label` to the new value assigned by the `CurrentNumber` property. You have one big problem, however: the `CurrentNumberChanged()` method is static, as it must be to work with the static `DependencyProperty` object. So how are you supposed to gain access to the `Label` for the current instance of `ShowNumberControl`? That reference is contained in the first `DependencyObject` parameter. You can find the new value using the incoming event arguments. Here is the necessary code that will change the `Content` property of the `Label`:

```
private static void CurrentNumberChanged(DependencyObject depObj,
    DependencyPropertyChangedEventArgs args)
{
    // Cast the DependencyObject into ShowNumberControl.
    ShowNumberControl c = (ShowNumberControl)depObj;

    // Get the Label control in the ShowNumberControl.
    Label theLabel = c.numberDisplay;

    // Set the Label with the new value.
    theLabel.Content = args.NewValue.ToString();
}
```

Whew! That was a long way to go just to change the output of a label. The benefit is that your `CurrentNumber` dependency property can now be the target of a WPF style, an animation object, the target of a data-binding operation, and so forth. If you run your application once again, you should now see the value change during execution.

That wraps up your look at WPF dependency properties. While I hope you have a much better idea about what these constructs allow you to do and have a better idea of how to make your own, please be aware that there are many details I have not covered here.

If you find yourself in a position where you are building a number of custom controls that support custom properties, please look up the topic “Properties” under the “WPF Fundamentals” node of the .NET Framework 4.6 SDK documentation. In it you will find many more examples of building dependency properties, attached properties, various ways to configure property metadata, and a slew of other details.

■ **Source Code** The CustomDepPropApp project is included in the Chapter 27 subdirectory.

Summary

This chapter examined several aspects of WPF controls, beginning with an overview of the control toolkit and the role of layout managers (panels). The first example gave you a chance to build a simple word processor application that illustrated the integrated spell-checking functionality of WPF, as well as how to build a main window with menu systems, status bars, and toolbars.

More importantly, you examined how to use WPF commands. Recall that you can attach these control-agnostic events to a UI element or an input gesture to inherit out-of-the-box services automatically (e.g., clipboard operations).

You also learned quite a bit about using Visual Studio to build out UIs via the integrated visual designers. Specifically, you built a complex user interface using numerous aspects of the tool, and you learned about the WPF Ink and Document APIs at the same time. You also received an introduction to WPF data-binding operations, including how to use the WPF `DataGrid` class to display data from your custom `AutoLot` database.

Finally, you investigated how WPF places a unique spin on traditional .NET programming primitives, specifically properties and events. As you have seen, a *dependency property* allows you to build a property that can integrate within the WPF set of services (animations, data bindings, styles, and so on). On a related note, *routed events* provide a way for an event to flow up or down a tree of markup.

CHAPTER 28



WPF Graphics Rendering Services

In this chapter, we'll examine the graphical rendering capabilities of WPF. As you'll see, WPF provides three separate ways to render graphical data: shapes, drawings, and visuals. After you understand the pros and cons of each approach, you will start learning about the world of interactive 2D graphics using the classes within `System.Windows.Shapes`. After this, you'll see how drawings and geometries allow you to render 2D data in a more lightweight manner. And last but not least, you'll learn how the visual layer gives you the greatest level of power and performance.

Along the way, you will explore a number of related topics, such as the creation of custom brushes and pens, how to apply graphical transformations to your renderings, and how to perform hit-test operations. In particular, you'll see how the integrated tools of Visual Studio, and an additional tool named Inkscape, can simplify your graphical coding endeavors.

■ **Note** Graphics are a key aspect of WPF development. Even if you are not building a graphics-heavy application (such as a video game or multimedia application), the topics in this chapter are critical when you work with services such as control templates, animations, and data-binding customization.

Understanding WPF's Graphical Rendering Services

WPF uses a particular flavor of graphical rendering that goes by the term *retained-mode graphics*. Simply put, this means that since you are using XAML or procedural code to generate graphical renderings, it is the responsibility of WPF to persist these visual items and ensure that they are correctly redrawn and refreshed in an optimal manner. Thus, when you render graphical data, it is always present, even when the end user hides the image by resizing or minimizing the window, by covering the window with another, and so forth.

In stark contrast, previous Microsoft graphical rendering APIs (including Windows Form's GDI+) were *immediate-mode* graphical systems. In this model, it was up to the programmer to ensure that rendered visuals were correctly "remembered" and updated during the life of the application. For example, in a Windows Forms application, rendering a shape such as a rectangle involved handling the `Paint` event (or overriding the virtual `OnPaint()` method), obtaining a `Graphics` object to draw the rectangle and, most important, adding the infrastructure to ensure that the image was persisted when the user resized the window (for example, creating member variables to represent the position of the rectangle and calling `Invalidate()` throughout your program).

The shift from immediate-mode to retained-mode graphics is indeed a good thing, as programmers have far less grungy graphics code to author and maintain. However, I'm not suggesting that the WPF graphics API is *completely* different from earlier rendering toolkits. For example, like GDI+, WPF supports various brush types and pen objects, techniques for hit-testing, clipping regions, graphical transformations, and so on. So, if you currently have a background in GDI+ (or C/C++-based GDI), you already know a good deal about how to perform basic renderings under WPF.

WPF Graphical Rendering Options

As with other aspects of WPF development, you have a number of choices regarding how to perform your graphical rendering, beyond the decision to do so via XAML or procedural C# code (or perhaps a combination of both). Specifically, WPF provides the following three distinct ways to render graphical data:

- **Shapes:** WPF provides the `System.Windows.Shapes` namespace, which defines a small number of classes for rendering 2D geometric objects (rectangles, ellipses, polygons, etc.). While these types are very simple to use, and very powerful, they do come with a fair amount of memory overhead if used with reckless abandon.
- **Drawings and Geometries:** The WPF API provides a second way to render graphical data, using descendants from the `System.Windows.Media.Drawing` abstract class. Using classes such as `GeometryDrawing` or `ImageDrawing` (in addition to various *geometry objects*) you can render graphical data in a more lightweight (but less feature-rich) manner.
- **Visuals:** The fastest and most lightweight way to render graphical data under WPF is using the visual layer, which is accessible only through C# code. Using descendants of `System.Windows.Media.Visual`, you can speak directly to the WPF graphical subsystem.

The reason for offering different ways to do the exact same thing (i.e., render graphical data) has to do with memory use and, ultimately, application performance. Because WPF is such a graphically intensive system, it is not unreasonable for an application to render hundreds or even thousands of different images on a window's surface, and the choice of implementation (shapes, drawings, or visuals) could have a huge impact.

Do understand that when you build a WPF application, chances are good you'll use all three options. As a rule of thumb, if you need a modest amount of *interactive* graphical data that can be manipulated by the user (receive mouse input, display tooltips, etc.), you'll want to use members in the `System.Windows.Shapes` namespace.

In contrast, drawings and geometries are more appropriate when you need to model complex, generally non-interactive, vector-based graphical data using XAML or C#. While drawings and geometries can still respond to mouse events, hit-testing, and drag-and-drop operations, you will typically need to author more code to do so.

Last but not least, if you require the fastest possible way to render massive amounts of graphical data, the visual layer is the way to go. For example, let's say you are using WPF to build a scientific application that can plot out thousands of points of data. Using the visual layer, you can render the plot points in the most optimal way possible. As you will see later in this chapter, the visual layer is only accessible via C# code, and is not XAML-friendly.

No matter which approach you take (shapes, drawings and geometries, or visuals) you will make use of common graphical primitives such as brushes (which fill interiors), pens (which draw exteriors), and transformation objects (which, well, transform the data). To begin the journey, you will start working with the classes of `System.Windows.Shapes`.

■ **Note** WPF also ships with a full-blown API that can be used to render and manipulate 3D graphics, which is not addressed in this edition of the text. Please consult the .NET Framework 4.6 SDK documentation if you are interested in incorporating 3D graphics into your applications.

Rendering Graphical Data Using Shapes

Members of the `System.Windows.Shapes` namespace provide the most straightforward, most interactive, yet most memory-intensive way to render a two-dimensional image. This namespace (defined in the `PresentationFramework.dll` assembly) is quite small and consists of only six sealed classes that extend the abstract `Shape` base class: `Ellipse`, `Rectangle`, `Line`, `Polygon`, `Polyline`, and `Path`.

Create a new WPF Application named `RenderingWithShapes`, and change the title of `MainWindow.xaml` to “Fun with Shapes!” Now, if you locate the abstract `Shape` class in the Visual Studio object browser (see Figure 28-1) and expand each of the parent nodes, you can see that each descendant of `Shape` receives a great deal of functionality up the inheritance chain.

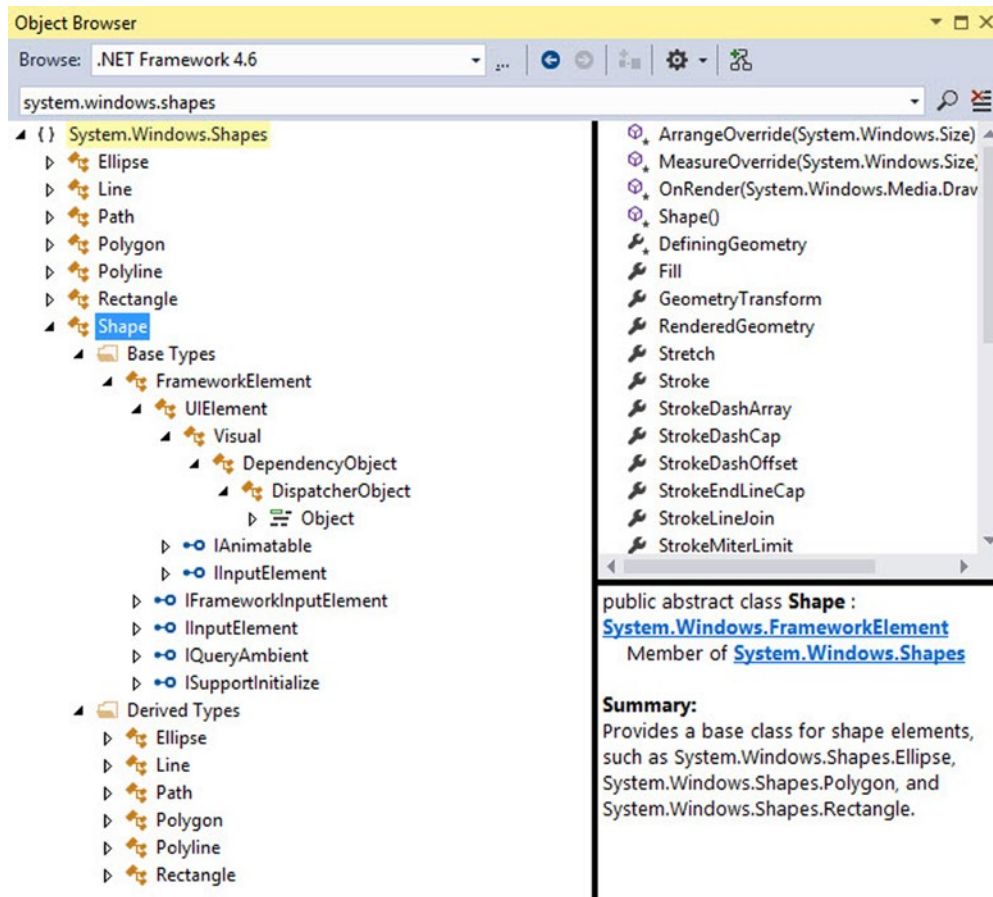

Figure 28-1. The `Shape` base class receives a good deal of functionality from its parent classes

Now, given your work in the previous two chapters, some of these parent classes might ring a bell. Recall, for example, that `UIElement` defines numerous methods to receive mouse input and deal with drag-and-drop events, while `FrameworkElement` defines members to deal with sizing, tooltips, mouse cursors, and whatnot. Given this inheritance chain, be aware that when you render graphical data using Shape-derived classes, the objects are just about as functional (as far as user interactivity is concerned) as a WPF control!

For example, determining whether the user has clicked on your rendered image is no more complicated than handling the `MouseDown` event. By way of a simple example, if you authored this XAML of a `Rectangle` object in the `Grid` of your initial `Window`

```
<Rectangle x:Name="myRect" Height="30" Width="30"
           Fill="Green" MouseDown="myRect_MouseDown"/>
```

you could implement a C# event handler for the `MouseDown` event that changes the rectangle's background color when clicked, like so:

```
private void myRect_MouseDown(object sender, MouseButtonEventArgs e)
{
    // Change color of Rectangle when clicked.
    myRect.Fill = Brushes.Pink;
}
```

Unlike with other graphical toolkits you may have used, you do *not* need to author a ton of infrastructure code that manually maps mouse coordinates to the geometry, manually calculates hit-testing, renders to an off-screen buffer, and so forth. The members of `System.Windows.Shapes` simply respond to the events you register with, just like a typical WPF control (e.g., `Button`, etc.).

The downside of all this out-of-the-box functionality is that the shapes do take up a fair amount of memory. Again, if you're building a scientific application that plots thousands of points on the screen, using shapes would be a poor choice (essentially, it would be about as memory-intensive as rendering thousands of `Button` objects!). However, when you need to generate an interactive 2D vector image, shapes are a wonderful choice.

Beyond the functionality inherited from the `UIElement` and `FrameworkElement` parent classes, `Shape` defines a number of members for each of the children; some of the more useful ones are shown in [Table 28-1](#).

Table 28-1. Key Properties of the Shape Base Class

| Properties | Meaning in Life |
|---|---|
| DefiningGeometry | Returns a Geometry object that represents the overall dimensions of the current shape. This object contains <i>only</i> the plot points that are used to render the data, and has no trace of the functionality from UIElement or FrameworkElement. |
| Fill | Allows you to specify a “brush object” to render the interior portion of a shape. |
| GeometryTransform | Allows you to apply transformations to a shape <i>before</i> it is rendered on the screen. The inherited RenderTransform property (from UIElement) applies the transformation <i>after</i> it has been rendered on the screen. |
| Stretch | Describes how to fill a shape within its allocated space, such as its position within a layout manager. This is controlled using the corresponding System.Windows.Media.Stretch enumeration. |
| Stroke | Defines a brush object, or in some cases, a pen object (which is really a brush in disguise) that is used to paint the border of a shape. |
| StrokeDashArray, StrokeEndLineCap, StrokeStartLineCap, StrokeThickness | These (and other) stroke-related properties control how lines are configured when drawing the border of a shape. In a majority of cases, these properties will configure the brush used to draw a border or line. |

■ **Note** If you forget to set the Fill and Stroke properties, WPF will give you “invisible” brushes and, therefore, the shape will not be visible on the screen!

Adding Rectangles, Ellipses, and Lines to a Canvas

Later in this chapter, you will learn to use Expression Design to generate XAML descriptions of graphical data. For now, you will build a WPF application that can render shapes using XAML and C#, and while doing so, learn a bit about the process of hit-testing. First, remove the current Rectangle description and the C# event handler logic. Now, update the initial XAML of the <Window> to define a <DockPanel> containing a (now empty) <ToolBar> and a <Canvas>. Note that each contained item has a fitting name via the Name property.

```
<DockPanel LastChildFill="True">
  <ToolBar DockPanel.Dock="Top" Name="mainToolBar" Height="50">
  </ToolBar>
  <Canvas Background="LightBlue" Name="canvasDrawingArea"/>
</DockPanel>
```

Now, populate the <ToolBar> with a set of <RadioButton> objects, each of which contains a specific Shape-derived class as content. Notice that each <RadioButton> is assigned to the same GroupName (to ensure mutual exclusivity) and is also given a fitting name.

```

<ToolBar DockPanel.Dock="Top" Name="mainToolBar" Height="50">
  <RadioButton Name="circleOption" GroupName="shapeSelection">
    <Ellipse Fill="Green" Height="35" Width="35" />
  </RadioButton>

  <RadioButton Name="rectOption" GroupName="shapeSelection">
    <Rectangle Fill="Red" Height="35"
      Width="35" RadiusY="10" RadiusX="10" />
  </RadioButton>

  <RadioButton Name="lineOption" GroupName="shapeSelection">
    <Line Height="35" Width="35"
      StrokeThickness="10" Stroke="Blue"
      X1="10" Y1="10" Y2="25" X2="25"
      StrokeStartLineCap="Triangle" StrokeEndLineCap="Round" />
  </RadioButton>
</ToolBar>

```

As you can see, declaring `Rectangle`, `Ellipse`, and `Line` objects in XAML is quite straightforward and requires little comment. Recall that the `Fill` property is used to specify a *brush* to paint the interior of a shape. When you require a solid-colored brush, just specify a hard-coded string of known values, and the underlying type converter will generate the correct object. One interesting feature of the `Rectangle` type is that it defines `RadiusX` and `RadiusY` properties to allow you to render curved corners.

`Line` represents its starting and end points using the `X1`, `X2`, `Y1`, and `Y2` properties (given that *height* and *width* make little sense when describing a line). Here you are setting up a few additional properties that control how to render the starting and ending points of the `Line`, as well as how to configure the stroke settings. Figure 28-2 shows the rendered toolbar, as seen through the Visual Studio WPF designer.

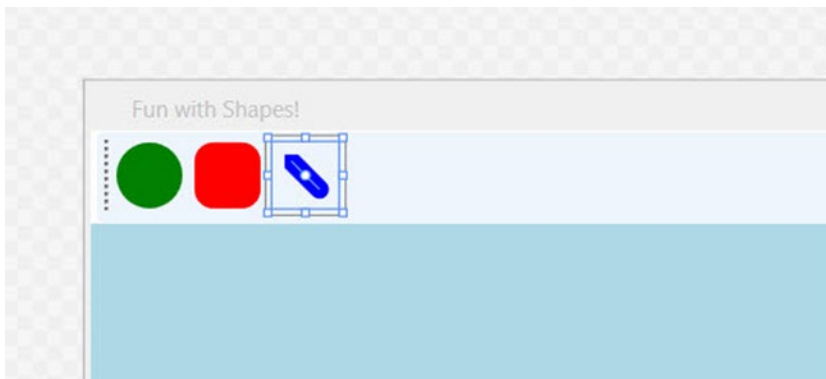

Figure 28-2. Using Shapes as content for a set of `RadioButtons`

Now, using the Properties window of Visual Studio, handle the `MouseDown` event for the Canvas, and the `Click` event for each `RadioButton`. In your C# file, your goal is to render the selected shape (a circle, square, or line) when the user clicks within the Canvas. First, define the following nested enum (and corresponding member variable) within your Window-derived class:

```
public partial class MainWindow : Window
{
    private enum SelectedShape
    { Circle, Rectangle, Line }

    private SelectedShape _currentShape;
    ...
}
```

Within each `Click` event handler, set the `currentShape` member variable to the correct `SelectedShape` value. For example, the following is the implementation code for the `Click` event of the `circleOption` `RadioButton`. Implement the remaining two `Click` handlers in a similar manner.

```
private void circleOption_Click(object sender, RoutedEventArgs e)
{
    _currentShape = SelectedShape.Circle;
}

private void rectOption_Click(object sender, RoutedEventArgs e)
{
    _currentShape = SelectedShape.Rectangle;
}

private void lineOption_Click(object sender, RoutedEventArgs e)
{
    _currentShape = SelectedShape.Line;
}
```

With the `MouseDown` event handler of the Canvas, you will render out the correct shape (of a predefined size), using the X,Y position of the mouse cursor as a starting point. Here is the complete implementation, with analysis to follow:

```
private void canvasDrawingArea_MouseLeftButtonDown(object sender, MouseButtonEventArgs e)
{
    Shape shapeToRender = null;

    // Configure the correct shape to draw.
    switch (_currentShape)
    {
        case SelectedShape.Circle:
            shapeToRender = new Ellipse() { Fill = Brushes.Green, Height = 35, Width = 35 };
            break;
        case SelectedShape.Rectangle:
            shapeToRender = new Rectangle()
            { Fill = Brushes.Red, Height = 35, Width = 35, RadiusX = 10, RadiusY = 10 };
            break;
    }
}
```

```

    case SelectedShape.Line:
        shapeToRender = new Line()
        {
            Stroke = Brushes.Blue,
            StrokeThickness = 10,
            X1 = 0, X2 = 50, Y1 = 0, Y2 = 50,
            StrokeStartLineCap= PenLineCap.Triangle,
            StrokeEndLineCap = PenLineCap.Round
        };
        break;
    default:
        return;
}

// Set top/left position to draw in the canvas.
Canvas.SetLeft(shapeToRender, e.GetPosition(canvasDrawingArea).X);
Canvas.SetTop(shapeToRender, e.GetPosition(canvasDrawingArea).Y);

// Draw shape!
canvasDrawingArea.Children.Add(shapeToRender);
}

```

■ **Note** You might notice that the `Ellipse`, `Rectangle`, and `Line` objects being created in this method have the same property settings as the corresponding XAML definitions! As you might hope, you can streamline this code, but that requires an understanding of the WPF object resources, which you will examine in [Chapter 29](#).

As you can see, you are testing the `currentShape` member variable to create the correct Shape-derived object. After this point, you set the top-left value within the Canvas using the incoming `MouseButtonEventArgs`. Last but not least, you add the new Shape-derived type to the collection of `UIElement` objects maintained by the Canvas. If you run your program now, you should be able to click anywhere in the canvas and see the selected shape rendered at the location of the left mouse-click.

Removing Rectangles, Ellipses, and Lines from a Canvas

With the Canvas maintaining a collection of objects, you might wonder how you can dynamically remove an item, perhaps in response to the user right-clicking on a shape. You can certainly do this using a class in the `System.Windows.Media` namespace called the `VisualTreeHelper`. [Chapter 29](#) will explain the roles of “visual trees” and “logical trees” in some detail. Until then, you can handle the `MouseRightButtonDown` event on your Canvas object and implement the corresponding event handler like so:

```

private void canvasDrawingArea_MouseRightButtonDown(object sender, MouseButtonEventArgs e)
{
    // First, get the X,Y location of where the user clicked.
    Point pt = e.GetPosition((Canvas)sender);

    // Use the HitTest() method of VisualTreeHelper to see if the user clicked
// on an item in the canvas.
    HitTestResult result = VisualTreeHelper.HitTest(canvasDrawingArea, pt);
}

```

```

// If the result is not null, they DID click on a shape!
if (result != null)
{
    // Get the underlying shape clicked on, and remove it from
    // the canvas.
    canvasDrawingArea.Children.Remove(result.VisualHit as Shape);
}
}

```

This method begins by obtaining the exact X,Y location the user clicked in the Canvas, and performs a hit-test operation via the static `VisualTreeHelper.HitTest()` method. The return value, a `HitTestResult` object, will be set to null if the user does not click on a `UIElement` within the Canvas. If `HitTestResult` is *not* null, you can obtain the underlying `UIElement` that was clicked via the `VisualHit` property, which you are casting into a `Shape`-derived object (remember, a `Canvas` can hold any `UIElement`, not just shapes!). Again, you'll get more details on exactly what a "visual tree" is in the next chapter.

■ **Note** By default, `VisualTreeHelper.HitTest()` returns the topmost `UIElement` clicked on, and does not provide information on other objects below that item (e.g., objects overlapping by Z-order).

With this modification, you should be able to add a shape to the canvas with a left mouse-click and delete an item from the canvas with a right mouse-click! Figure 28-3 shows the functionality of the current example.

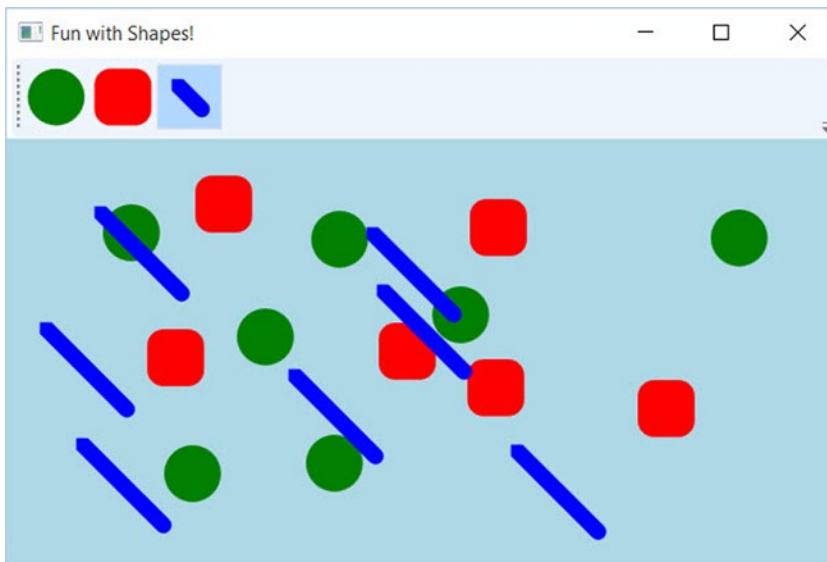

Figure 28-3. *Fun with shapes*

So far, so good. At this point, you have used Shape-derived objects to render content on `RadioButton`s using XAML and populated a `Canvas` using C#. You will add a bit more functionality to this example when you examine the role of brushes and graphical transformations. On a related note, a different example in this chapter will illustrate drag-and-drop techniques on `UIElement` objects. Until then, let's examine the remaining members of `System.Windows.Shapes`.

Working with Polylines and Polygons

The current example used only three of the Shape-derived classes. The remaining child classes (`Polyline`, `Polygon`, and `Path`) are extremely tedious to render correctly without tool support (such as Expression Blend or other tools that can create vector graphics), simply because they require a large number of plot points to represent their output. You'll learn about the role of Expression Design in just a moment, but until then, here is an overview of the remaining Shapes types.

The `Polyline` type lets you define a collection of (x, y) coordinates (via the `Points` property) to draw a series of line segments that do not require connecting ends. The `Polygon` type is similar; however, it is programmed so that it will always close the starting and ending points and fill the interior with the specified brush. Assume you have authored the following `<StackPanel>` in the Kaxaml editor, or better yet, in the custom XAML editor you created in Chapter 26:

```
<!-- Polylines do not automatically connect the ends. -->
<Polyline Stroke = "Red" StrokeThickness = "20" StrokeLineJoin = "Round"
          Points = "10,10 40,40 10,90 300,50"/>

<!-- A Polygon always closes the end points. -->
<Polygon Fill = "AliceBlue" StrokeThickness = "5" Stroke = "Green"
         Points = "40,10 70,80 10,50" />
```

Figure 28-4 shows the rendered output in MyXAMLPad.

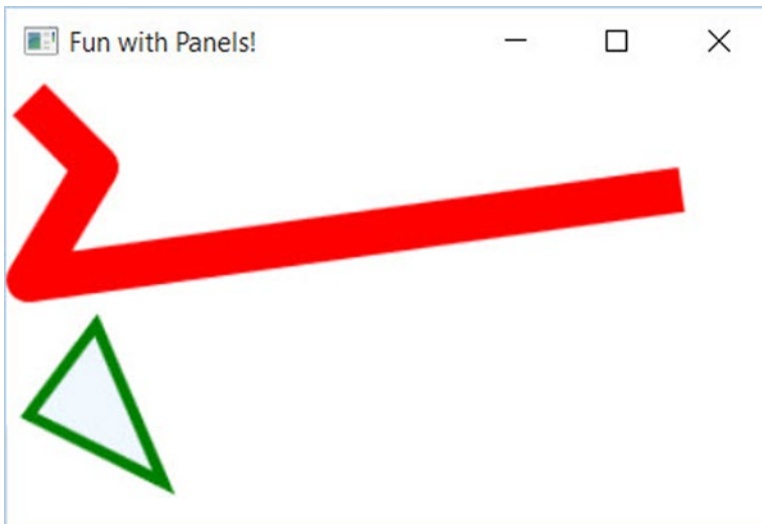

Figure 28-4. Polygons and polylines

Working with Paths

Using the `Rectangle`, `Ellipse`, `Polygon`, `Polyline`, and `Line` types alone to draw a detailed 2D vector image would be extremely complex, as these primitives do not allow you to easily capture graphical data such as curves, unions of overlapping data, and so forth. The final `Shape`-derived class, `Path`, provides the ability to define complex 2D graphical data represented as a collection of independent *geometries*. After you have defined a collection of such geometries, you can assign them to the `Data` property of the `Path` class, where this information will be used to render your complex 2D image.

The `Data` property takes a `System.Windows.Media.Geometry`-derived class, which contains the key members described in Table 28-2.

Table 28-2. Select Members of the `System.Windows.Media.Geometry` Type

| Member | Meaning in Life |
|--------------------------------|---|
| <code>Bounds</code> | Establishes the current bounding rectangle containing the geometry. |
| <code>FillContains()</code> | Determines whether a given <code>Point</code> (or other <code>Geometry</code> object) is within the bounds of a particular <code>Geometry</code> -derived class. This is useful for hit-testing calculations. |
| <code>GetArea()</code> | Returns the entire area a <code>Geometry</code> -derived type occupies. |
| <code>GetRenderBounds()</code> | Returns a <code>Rect</code> that contains the smallest possible rectangle that could be used to render the <code>Geometry</code> -derived class. |
| <code>Transform</code> | Assigns a <code>Transform</code> object to the geometry to alter the rendering. |

The classes that extend `Geometry` (see Table 28-3) look very much like their `Shape`-derived counterparts. For example, `EllipseGeometry` has similar members to `Ellipse`. The big distinction is that `Geometry`-derived classes *do not know* how to render themselves directly because they are not `UIElement`s. Rather, `Geometry`-derived classes represent little more than a collection of plot-point data, which say in effect “If a `Path` uses my data, this is how I would render myself.”

Table 28-3. *Geometry-Derived Classes*

| Geometry Class | Meaning in Life |
|--------------------------------|---|
| <code>LineGeometry</code> | Represents a straight line |
| <code>RectangleGeometry</code> | Represents a rectangle |
| <code>EllipseGeometry</code> | Represents an ellipse |
| <code>GeometryGroup</code> | Allows you to group together several <code>Geometry</code> objects |
| <code>CombinedGeometry</code> | Allows you to merge two different <code>Geometry</code> objects into a single shape |
| <code>PathGeometry</code> | Represents a figure composed of lines and curves |

■ **Note** `Path` is not the only class in WPF that can use a collection of geometries. For example, `DoubleAnimationUsingPath`, `DrawingGroup`, `GeometryDrawing`, and even `UIElement` can all use geometries for rendering, using the `PathGeometry`, `ClipGeometry`, `Geometry`, and `Clip` properties, respectively.

The following is a Path that makes use of a few Geometry-derived types. Notice that you are setting the Data property of Path to a GeometryGroup object that contains other Geometry-derived objects such as EllipseGeometry, RectangleGeometry, and LineGeometry. Figure 28-5 shows the output.

```
<!-- A Path contains a set of geometry objects,
      set with the Data property. -->
<Path Fill = "Orange" Stroke = "Blue" StrokeThickness = "3">
  <Path.Data>
    <GeometryGroup>
      <EllipseGeometry Center = "75,70"
        RadiusX = "30" RadiusY = "30" />
      <RectangleGeometry Rect = "25,55 100 30" />
      <LineGeometry StartPoint="0,0" EndPoint="70,30" />
      <LineGeometry StartPoint="70,30" EndPoint="0,30" />
    </GeometryGroup>
  </Path.Data>
</Path>
```

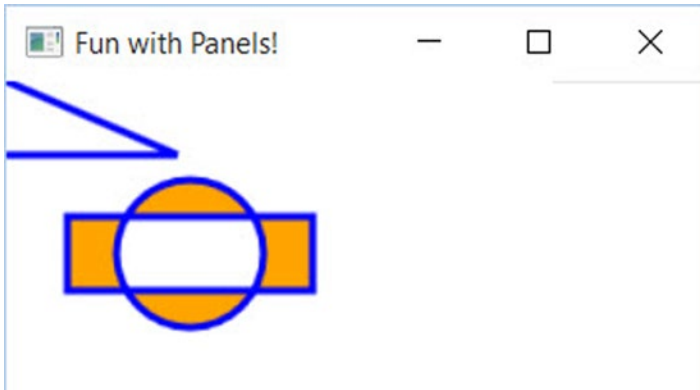

Figure 28-5. A Path containing various Geometry objects

The image in Figure 28-5 could have been rendered using the Line, Ellipse, and Rectangle classes shown earlier. However, this would have put various UIElement objects in memory. When you use geometries to model the plot points of what to draw, and then place the geometry collection into a container that can render the data (Path, in this case), you reduce the memory overhead.

Now recall that Path has the same inheritance chain as any other member of System.Windows.Shapes, and therefore has the ability to send the same event notifications as other UIElements. Thus, if you were to define this same <Path> element in a Visual Studio project, you could determine whether the user clicked anywhere in the sweeping line simply by handling a mouse event (remember, Xaml does not allow you to handle events for the markup you have authored).

The Path Modeling “Mini-Language”

Of all the classes listed in Table 28-3, `PathGeometry` is the most complex to configure in terms of XAML or code. This has to do with the fact that each *segment* of the `PathGeometry` is composed of objects that contain various segments and figures (for example, `ArcSegment`, `BezierSegment`, `LineSegment`, `PolyBezierSegment`, `PolyLineSegment`, `PolyQuadraticBezierSegment`, etc.). Here is an example of a `Path` object whose `Data` property has been set to a `PathGeometry` composed of various figures and segments:

```
<Path Stroke="Black" StrokeThickness="1" >
  <Path.Data>
    <PathGeometry>
      <PathGeometry.Figures>
        <PathFigure StartPoint="10,50">
          <PathFigure.Segments>
            <BezierSegment
              Point1="100,0"
              Point2="200,200"
              Point3="300,100" />
            <LineSegment Point="400,100" />
            <ArcSegment
              Size="50,50" RotationAngle="45"
              IsLargeArc="True" SweepDirection="Clockwise"
              Point="200,100" />
          </PathFigure.Segments>
        </PathFigure>
      </PathGeometry.Figures>
    </PathGeometry>
  </Path.Data>
</Path>
```

Now, to be perfectly honest, very few programmers will ever need to manually build complex 2D images by directly describing `Geometry`- or `PathSegment`-derived classes. Later on in this chapter, you will learn how to convert vector graphics into path statements that can be used in XAML.

Even with the assistance of these tools, the amount of XAML required to define a complex `Path` object would be ghastly, as the data consists of full descriptions of various `Geometry`- or `PathSegment`-derived classes. In order to produce more concise and compact markup, the `Path` class has been designed to understand a specialized “mini-language.”

For example, rather than setting the `Data` property of `Path` to a collection of `Geometry`- and `PathSegment`-derived types, you can set the `Data` property to a single string literal containing a number of known symbols and various values that define the shape to be rendered. Here is a simple example, and the resulting output is shown in Figure 28-6:

```
<Path Stroke="Black" StrokeThickness="3"
  Data="M 10,75 C 70,15 250,270 300,175 H 240" />
```

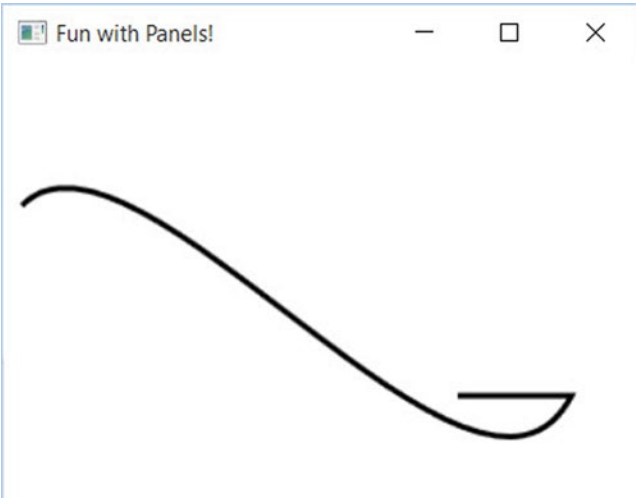

Figure 28-6. The path mini-language allows you to compactly describe a *Geometry/PathSegment* object model

The M command (short for *move*) takes an X,Y position that represents the starting point of the drawing. The C command takes a series of plot points to render a *curve* (a cubic Bézier curve to be exact), while H draws a *horizontal* line.

Now, to be perfectly honest, the chances that you will ever need to manually build or parse a string literal containing path mini-language instructions are slim to none. However, at the very least, you will no longer be surprised when you view XAML-generated dedicated tools. If you are interested in examining the details of this particular grammar, look up “Path Markup Syntax” in the .NET Framework 4.6 SDK documentation.

WPF Brushes and Pens

Each of the WPF graphical rendering options (shape, drawing and geometries, and visuals) makes extensive use of *brushes*, which allow you to control how the interior of a 2D surface is filled. WPF provides six different brush types, all of which extend `System.Windows.Media.Brush`. While `Brush` is abstract, the descendants described in Table 28-4 can be used to fill a region with just about any conceivable option.

Table 28-4. *WPF Brush-Derived Types*

| Brush Type | Meaning in Life |
|----------------------------------|---|
| <code>DrawingBrush</code> | Paints an area with a Drawing-derived object (<code>GeometryDrawing</code> , <code>ImageDrawing</code> , or <code>VideoDrawing</code>) |
| <code>ImageBrush</code> | Paints an area with an image (represented by an <code>ImageSource</code> object) |
| <code>LinearGradientBrush</code> | Paints an area with a linear gradient |
| <code>RadialGradientBrush</code> | Paints an area with a radial gradient |
| <code>SolidColorBrush</code> | Paints a single color, set with the <code>Color</code> property |
| <code>VisualBrush</code> | Paints an area with a Visual-derived object (<code>DrawingVisual</code> , <code>Viewport3DVisual</code> , and <code>ContainerVisual</code>) |

The `DrawingBrush` and `VisualBrush` classes allow you to build a brush based on an existing Drawing- or Visual-derived class. These brush classes are used when you are working with the other two graphical options of WPF (drawings or visuals) and will be examined later in this chapter.

`ImageBrush`, as the name suggests, lets you build a brush that displays image data from an external file or embedded application resource, by setting the `ImageSource` property. The remaining brush types (`LinearGradientBrush` and `RadialGradientBrush`) are quite straightforward to use, though typing in the required XAML can be a tad verbose. Thankfully, Visual Studio supports integrated brush editors that make it simple to generate stylized brushes.

Configuring Brushes Using Visual Studio

Let's update your WPF drawing program, `RenderingWithShapes`, to use some more interesting brushes. The three shapes you've employed so far to render data on your toolbar use simple, solid colors, so you can capture their values using simple string literals. To spice things up a tad, you will now use the integrated brush editor. Ensure that the XAML editor of your initial window is the open window within the IDE, and select the `Ellipse` element. Now, in the Properties window, locate the `Brush` category and then click `Fill` property listed on the top (see Figure 28-7).

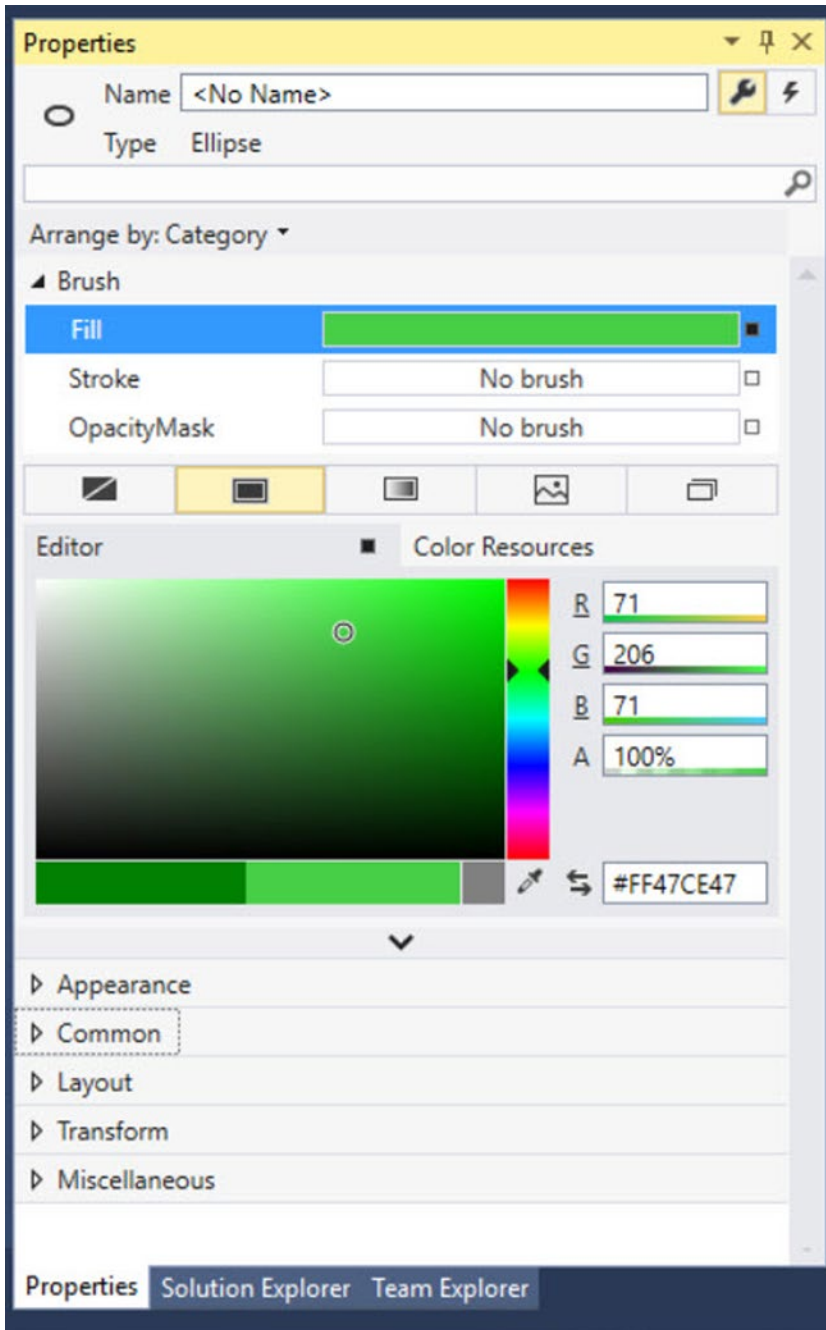

Figure 28-7. Any property that requires a brush can be configured with the integrated brush editor

At the top of the Brushes editor, you will see a set of properties that are all “brush compatible” for the selected item (i.e., `Fill`, `Stroke`, and `OpacityMask`). Below this, you will see a series of tabs that allow you to configure different types of brushes, including the current solid color brush. You can use the color selector tool, as well as the ARGB (alpha, red, green, and blue, where “alpha” controls transparency) editors to control the color of the current brush. Using these sliders and the related color selection area, you can create any sort of solid color. Use these tools to change the `Fill` color of your `Ellipse`, and view the resulting XAML. You’ll notice the color is stored as a hexadecimal value, such as

```
<Ellipse Fill="#FF47CE47" Height="35" Width="35" />
```

More interestingly, this same editor allows you to configure gradient brushes, which are used to define a series of colors and transition points. Recall that this Brushes editor provides you with a set of tabs, the first of which lets you set a *null brush* for no rendered output. The other four allow you to set up a solid color brush (what you just examined), gradient brush, tile brush, or image brush.

Click the gradient brush button and the editor will display a few new options (see Figure 28-8). The three buttons on the lower left allow you to pick a linear gradient, a radial gradient, or to reverse the gradient stops. The bottommost strip will show you the current color of each gradient stop, each of which is marked by a “thumb” on the strip. As you drag these thumbs around the gradient strip, you can control the gradient offset. Furthermore, when you click on a given thumb, you can change the color for that particular gradient stop via the color selector. Finally, if you click directly on the gradient strip, you can add additional gradient stops.

Take a few minutes to play around with this editor to build a radial gradient brush containing three gradient stops, set to your colors of choice. Figure 28-8 shows the brush you just constructed, using three different shades of green.

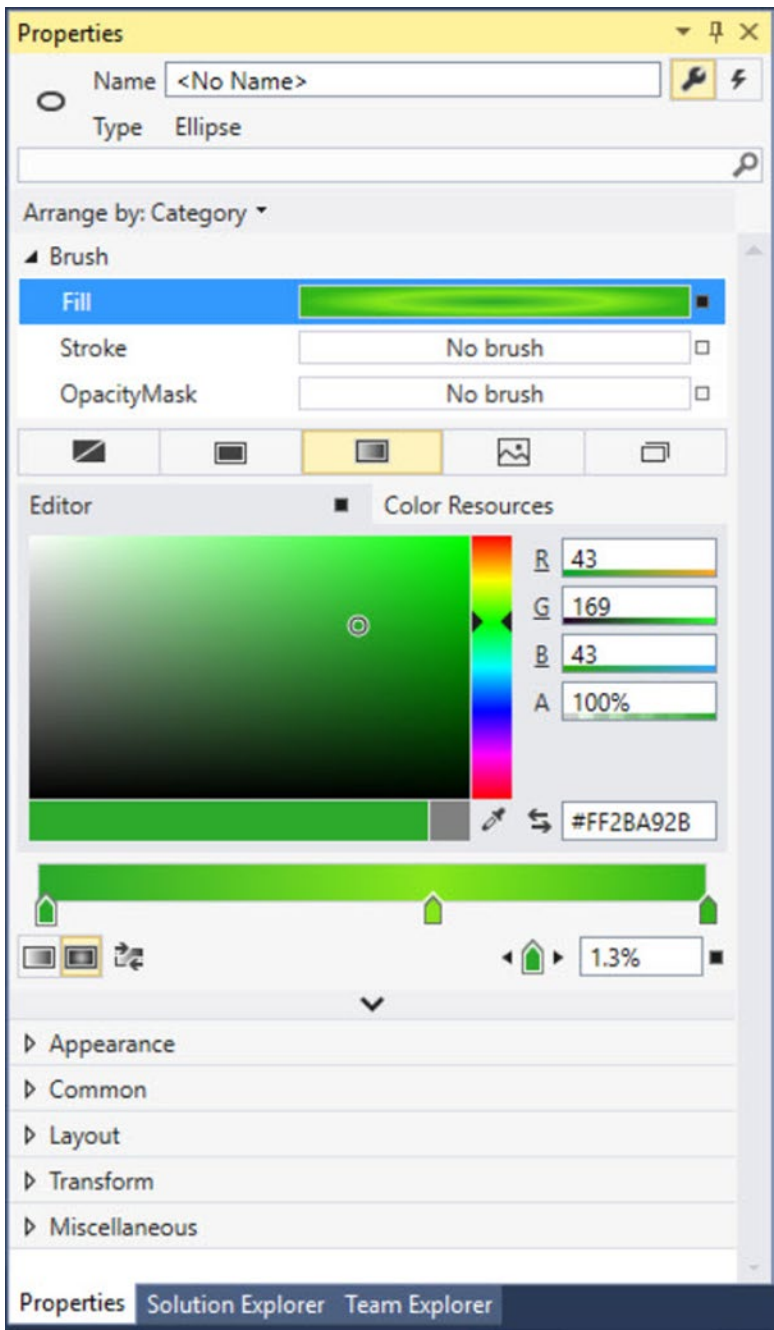

Figure 28-8. The Visual Studio brush editor allows you to build basic gradient brushes

When you are done, the IDE will update your XAML with a custom brush, set to a brush-compatible property (the `Fill` property of the `Ellipse` in this example) using property-element syntax, such as

```
<Ellipse Height="35" Width="35">
  <Ellipse.Fill>
    <RadialGradientBrush>
      <GradientStop Color="#FF87E71B" Offset="0.589" />
      <GradientStop Color="#FF2BA92B" Offset="0.013" />
      <GradientStop Color="#FF34B71B" Offset="1" />
    </RadialGradientBrush>
  </Ellipse.Fill>
</Ellipse>
```

Configuring Brushes in Code

Now that you have built a custom brush for the XAML definition of your `Ellipse`, the corresponding C# code is out of date, in that it will still render a solid green circle. To sync things back up, update the correct case statement to use the same brush you just created. The following is the necessary update, which looks more complex than you might expect, just because you are converting the hexadecimal value to a proper `Color` object via the `System.Windows.Media.ColorConverter` class (see Figure 28-9 for the modified output):

```
case SelectedShape.Circle:
    shapeToRender = new Ellipse() { Height = 35, Width = 35 };

    // Make a RadialGradientBrush in code!
    RadialGradientBrush brush = new RadialGradientBrush();
    brush.GradientStops.Add(new GradientStop(
        (Color)ColorConverter.ConvertFromString("#FF87E71B"), 0.589));
    brush.GradientStops.Add(new GradientStop(
        (Color)ColorConverter.ConvertFromString("#FF2BA92B"), 0.013));
    brush.GradientStops.Add(new GradientStop(
        (Color)ColorConverter.ConvertFromString("#FF34B71B"), 1));

    shapeToRender.Fill = brush;
    break;
```

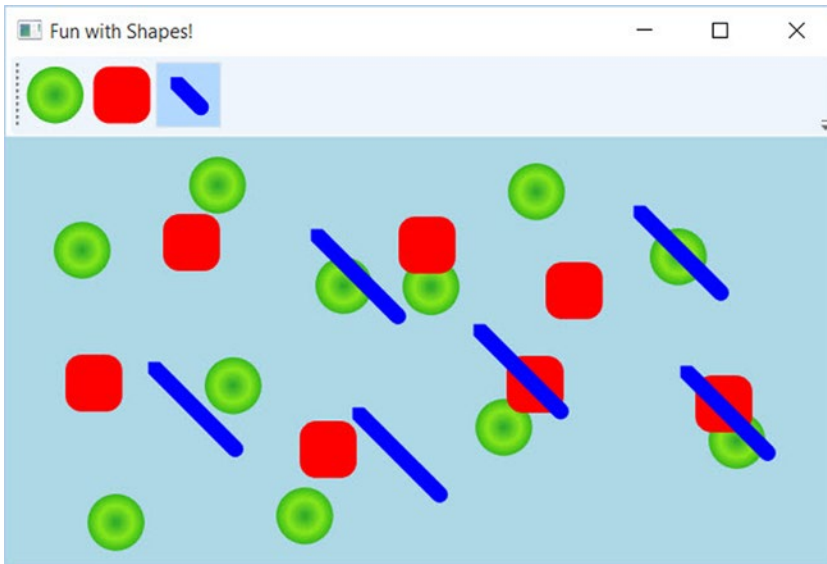

Figure 28-9. Drawing circles with a bit more pizzazz!

By the way, you can build `GradientStop` objects by specifying a simple color as the first constructor parameter using the `Colors` enumeration, which returns a configured `Color` object.

```
GradientStop g = new GradientStop(Colors.Aquamarine, 1);
```

Or, if you require even finer control, you can pass in a configured `Color` object, like so:

```
Color myColor = new Color() { R = 200, G = 100, B = 20, A = 40 };
GradientStop g = new GradientStop(myColor, 34);
```

Of course, the `Colors` enum and `Color` class are not limited to gradient brushes. You can use them anytime you need to represent a color value in code.

Configuring Pens

In comparison with brushes, a *pen* is an object for drawing borders of geometries, or in the case of the `Line` or `PolyLine` class, the line geometry itself. Specifically, the `Pen` class allows you to draw a specified thickness, represented by a double value. In addition, a `Pen` can be configured with the same sort of properties seen in the `Shape` class, such as starting and stopping pen caps, dot-dash patterns, and so forth. For example, you can add the following markup to a shape to define the pen attributes:

```
<Pen Thickness="10" LineJoin="Round" EndLineCap="Triangle" StartLineCap="Round" />
```

In many cases, you won't need to directly create a `Pen` object because this will be done indirectly when you assign a value to properties, such as `StrokeThickness` to a `Shape`-derived type (as well as other `UIElements`). However, building a custom `Pen` object is very handy when working with `Drawing`-derived types (described later in the chapter). Visual Studio does not have a pen editor, *per se*, but it does allow you to configure all of the stroke-centric properties of a selected item using the Properties window.

Applying Graphical Transformations

To wrap up our discussion of using shapes, let's address the topic of *transformations*. WPF ships with numerous classes that extend the `System.Windows.Media.Transform` abstract base class. Table 28-5 documents many of the key out-of-the-box `Transform`-derived classes.

Table 28-5. Key Descendants of the `System.Windows.Media.Transform` Type

| Type | Meaning in Life |
|---------------------------------|---|
| <code>MatrixTransform</code> | Creates an arbitrary matrix transformation that is used to manipulate objects or coordinate systems in a 2D plane |
| <code>RotateTransform</code> | Rotates an object clockwise about a specified point in a 2D (x, y) coordinate system |
| <code>ScaleTransform</code> | Scales an object in the 2D (x, y) coordinate system |
| <code>SkewTransform</code> | Skews an object in the 2D (x, y) coordinate system |
| <code>TranslateTransform</code> | Translates (moves) an object in the 2-D (x-y) coordinate system |
| <code>TransformGroup</code> | Represents a composite <code>Transform</code> composed of other <code>Transform</code> objects |

Transformations can be applied to any `UIElement` (e.g., descendants of `Shape` as well as controls such as `Buttons`, `TextBoxes`, and the like). Using these transformation classes, you can render graphical data at a given angle, skew the image across a surface, and expand, shrink, or flip the target item in a variety of ways.

■ **Note** While transformation objects can be used anywhere, you will find them most useful when working with WPF animations and custom control templates. As you will see later in the chapter, you can use WPF animations to incorporate visual cues to the end user for a custom control.

Transformations (or a whole set of them) can be assigned to a target object (e.g., `Button`, `Path`, etc.) using two common properties, `LayoutTransform` and `RenderTransform`.

The `LayoutTransform` property is helpful in that the transformation occurs *before* elements are rendered into a layout manager, and therefore the transformation will not affect z-ordering operations (in other words, the transformed image data will not overlap).

The `RenderTransform` property, on the other hand, occurs after the items are in their container, and therefore it is quite possible that elements can be transformed in such a way that they could overlap each other, based on how they were arranged in the container.

A First Look at Transformations

You will add some transformational logic to your `RenderingWithShapes` project in just a moment. However, to see transformation objects in action, open Kaxaml (or your custom XAML editor) and define a simple `<StackPanel>` in the root `<Page>` or `<Window>`, and set the `Orientation` property to `Horizontal`. Now, add the following `<Rectangle>`, which will be drawn at a 45-degree angle using a `RotateTransform` object:

```
<!-- A Rectangle with a rotate transformation. -->
<Rectangle Height ="100" Width ="40" Fill ="Red">
  <Rectangle.LayoutTransform>
    <RotateTransform Angle ="45"/>
  </Rectangle.LayoutTransform>
</Rectangle>
```

Here is a `<Button>` that is skewed across the surface by 20 degrees, using a `<SkewTransform>`:

```
<!-- A Button with a skew transformation. -->
<Button Content ="Click Me!" Width="95" Height="40">
  <Button.LayoutTransform>
    <SkewTransform AngleX ="20" AngleY ="20"/>
  </Button.LayoutTransform>
</Button>
```

And for good measure, here is an `<Ellipse>` that is scaled by 20 degrees with a `ScaleTransform` (note the values set to the initial `Height` and `Width`), as well as a `<TextBox>` that has a group of transformation objects applied to it:

```
<!-- An Ellipse that has been scaled by 20%. -->
<Ellipse Fill ="Blue" Width="5" Height="5">
  <Ellipse.LayoutTransform>
    <ScaleTransform ScaleX ="20" ScaleY ="20"/>
  </Ellipse.LayoutTransform>
</Ellipse>

<!-- A TextBox that has been rotated and skewed. -->
<TextBox Text ="Me Too!" Width="50" Height="40">
  <TextBox.LayoutTransform>
    <TransformGroup>
      <RotateTransform Angle ="45"/>
      <SkewTransform AngleX ="5" AngleY ="20"/>
    </TransformGroup>
  </TextBox.LayoutTransform>
</TextBox>
```

Note that when a transformation is applied, you are not required to perform any manual calculations to correctly respond to hit-testing, input focus, or whatnot. The WPF graphics engine handles such tasks on your behalf. For example, in [Figure 28-10](#), you can see that the `TextBox` is still responsive to keyboard input.

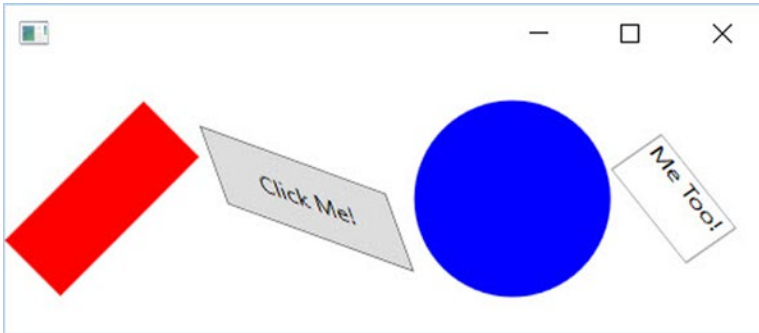

Figure 28-10. The results of graphical transformation objects

Transforming Your Canvas Data

Now, let's incorporate some transformational logic into your `RenderingWithShapes` example. In addition to applying a transformation object to a single item (e.g., `Rectangle`, `TextBox`, etc.), you can also apply transformation objects to a layout manager in order to transform all of the internal data. You could, for example, render the entire `<DockPanel>` of the main window at an angle:

```
<DockPanel LastChildFill="True">
  <DockPanel.LayoutTransform>
    <RotateTransform Angle="45"/>
  </DockPanel.LayoutTransform>
  ...
</DockPanel>
```

This is a bit extreme for this example, so let's add a final (less aggressive) feature that allows the user to flip the entire Canvas and all contained graphics. Begin by adding a final `<ToggleButton>` to your `<ToolBar>`, defined as follows:

```
<ToggleButton Name="flipCanvas" Click="flipCanvas_Click" Content="Flip Canvas!"/>
```

Within the `Click` event handler, create a `RotateTransform` object and connect it to the `Canvas` object via the `LayoutTransform` property if this new `ToggleButton` is clicked. If the `ToggleButton` is not clicked, remove the transformation by setting the same property to `null`.

```
private void flipCanvas_Click(object sender, RoutedEventArgs e)
{
  if (flipCanvas.IsChecked == true)
  {
    RotateTransform rotate = new RotateTransform(-180);
    canvasDrawingArea.LayoutTransform = rotate;
  }
  else
  {
    canvasDrawingArea.LayoutTransform = null;
  }
}
```

Run your application and add a bunch of graphics throughout the canvas area. If you click your new button, you will find that the shape data flows outside of the boundaries of the canvas! This is because you have not defined a clipping region (see Figure 28-11).

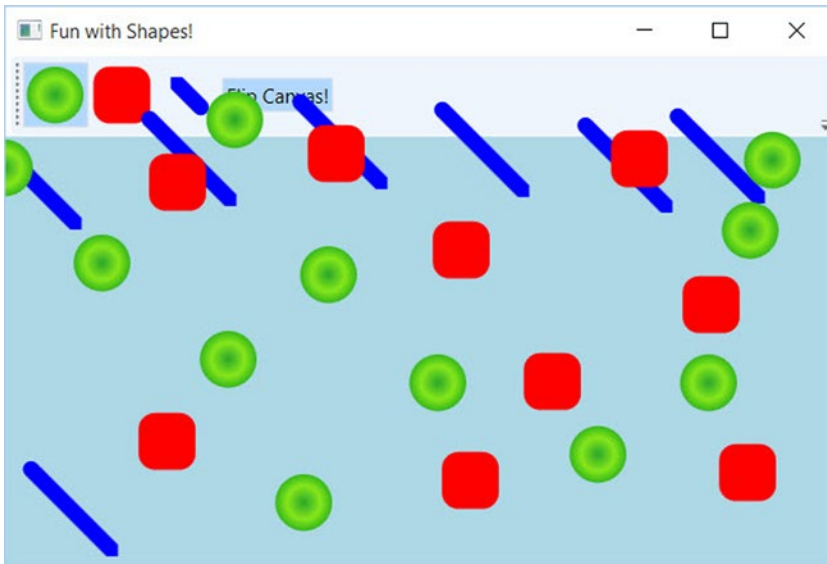

Figure 28-11. Oops! Your data is flowing outside of the canvas after the transformation!

Fixing this is trivial. Rather than manually authoring complex clipping-logic code, simply set the `ClipToBounds` property of the `<Canvas>` to `true`, which prevents child elements from being rendered outside the parent's boundaries. If you run your program again, you'll find the data will not bleed off the canvas boundary.

```
<Canvas ClipToBounds = "True" ... >
```

The last tiny modification to make has to do with the fact that when you flip the canvas by pressing your toggle button, and then click the canvas to draw a new shape, the point at which you click is *not* the point where the graphical data is applied. Rather, the data is rendered above the mouse cursor.

To resolve this issue, check out the solution code for this example. The key is to add one final Boolean member variable (`isFlipped`), which will apply the same transformation object to the shape being draw before the rendering occurs (via `RenderTransform`). Here is the crux of the code:

```
private bool _isFlipped = false;
private void canvasDrawingArea_MouseLeftButtonDown(object sender, MouseButtonEventArgs e)
{
    Shape shapeToRender = null;
    ...

    // isFlipped is a private boolean field. This is toggled when the
    // toggle button is clicked.
    if (_isFlipped)
```

```

{
    RotateTransform rotate = new RotateTransform(-180);
    shapeToRender.RenderTransform = rotate;
}
// Set top/left to draw in the canvas.
Canvas.SetLeft(shapeToRender, e.GetPosition(canvasDrawingArea).X);
Canvas.SetTop(shapeToRender, e.GetPosition(canvasDrawingArea).Y);

// Draw shape!
canvasDrawingArea.Children.Add(shapeToRender);
}
private void flipCanvas_Click(object sender, RoutedEventArgs e)
{
    if (flipCanvas.IsChecked == true)
    {
        RotateTransform rotate = new RotateTransform(-180);
        canvasDrawingArea.LayoutTransform = rotate;
    }
    else
    {
        canvasDrawingArea.LayoutTransform = null;
    }
}

```

This wraps up your examination of `System.Windows.Shapes`, brushes, and transformations. Before looking at the role of rendering graphics using drawings and geometries, let's see how Visual Studio can be used to simplify how you work with primitive graphics.

■ **Source Code** The `RenderingWithShapes` project can be found in the [Chapter 28](#) subdirectory.

Working with the Visual Studio Transform Editor

In the previous example, you applied various transformations by manually entering markup and authoring some C# code. While this is certainly useful, you will be happy to know that the latest version of Visual Studio ships with an integrated transformation editor. It is not as powerful as the tooling in Expression Blend, but it does allow you to easily generate the necessary transformational markup using integrated tools. Recall that any UI element can be the recipient of transformational services, including a layout system containing various UI elements. To illustrate the use of Visual Studio's transform editor, create a new WPF Application named `FunWithTransforms`.

Building the Initial Layout

First, split your initial Grid into two columns using the integrated grid editor (the exact size does not matter). Now, locate the StackPanel control within your Toolbox and add this item to take up the entire space of the first column of the Grid, like so:

```
<Grid>
  <Grid.ColumnDefinitions>
    <ColumnDefinition Width="*" />
    <ColumnDefinition Width="*" />
  </Grid.ColumnDefinitions>
  <StackPanelGrid.Row="0" Grid.Column="0"></StackPanel>
</Grid>
```

Next, select your new StackPanel in the Document Outline panel and add three Button controls to the StackPanel container (see Figure 28-12).

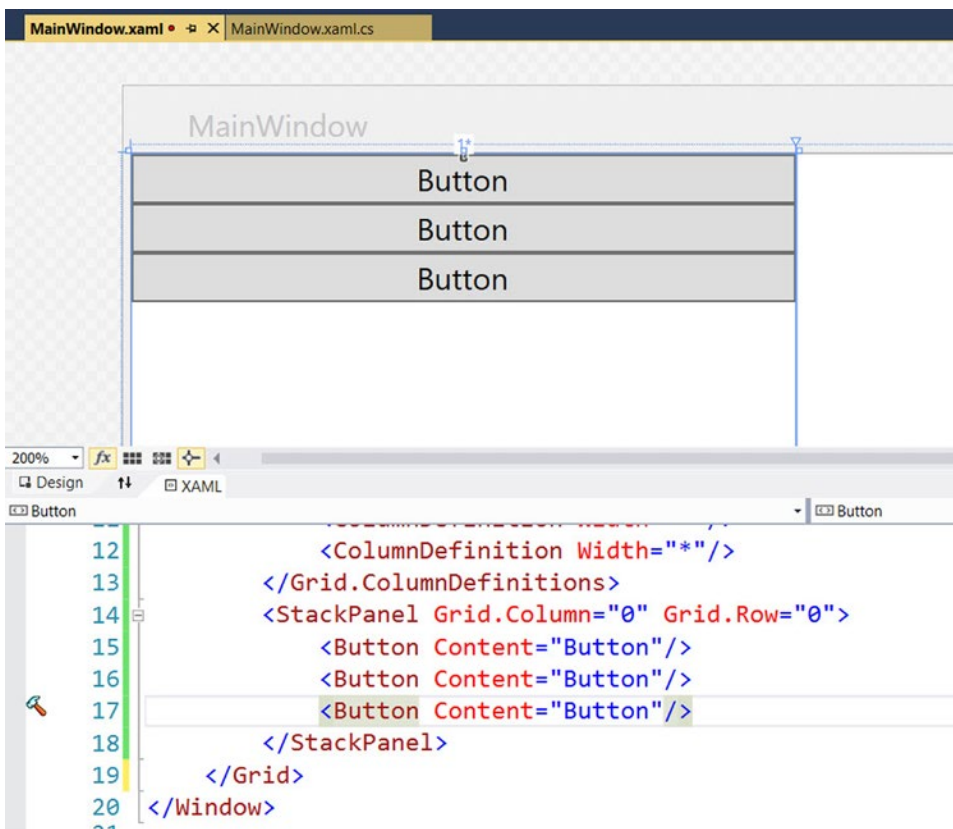

Figure 28-12. A StackPanel of Button controls

Now, select each Button, one at a time, and change the Content property (located in the Common Properties section of the Properties window) to the values Skew, Rotate, and Flip. As well, use the Name area of the Properties panel to give each button a proper name, such as btnSkew, btnRotate, and btnFlip; and using the Events tab of the Properties panel, handle the Click event for each Button. You will implement these handlers in just a bit.

To finalize the UI, create a graphic of your choosing (using any of the techniques seen in this chapter) defined in the second column of the Grid. Figure 28-13 shows the final layout. Here, there are two `Ellipse` controls grouped into a `Canvas` control, which has been named `myCanvas`.

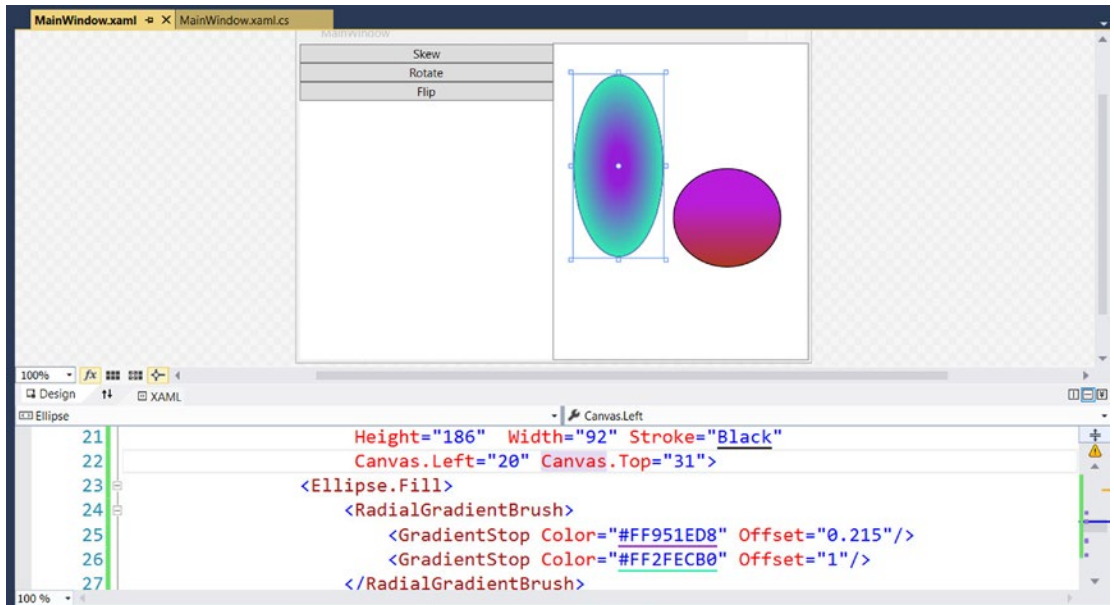

Figure 28-13. The layout of your transformation example

The markup used in the sample is listed here:

```

<Canvas x:Name="myCanvas" Grid.Column="1" Grid.Row="0">
  <Ellipse HorizontalAlignment="Left" VerticalAlignment="Top"
    Height="186" Width="92" Stroke="Black"
    Canvas.Left="20" Canvas.Top="31">
    <Ellipse.Fill>
      <RadialGradientBrush>
        <GradientStop Color="#FF951ED8" Offset="0.215"/>
        <GradientStop Color="#FF2FECB0" Offset="1"/>
      </RadialGradientBrush>
    </Ellipse.Fill>
  </Ellipse>
  <Ellipse HorizontalAlignment="Left" VerticalAlignment="Top"
    Height="101" Width="110" Stroke="Black"
    Canvas.Left="122" Canvas.Top="126">
    <Ellipse.Fill>
      <LinearGradientBrush EndPoint="0.5,1" StartPoint="0.5,0">
        <GradientStop Color="#FFB91DDC" Offset="0.355"/>
        <GradientStop Color="#FFB0381D" Offset="1"/>
      </LinearGradientBrush>
    </Ellipse.Fill>
  </Ellipse>
</Canvas>

```

Applying Transformations at Design Time

As mentioned, Visual Studio provides an integrated Transform editor, which can be found in the Properties panel. Locate this area, and make sure you expand the Transform section to view the RenderTransform and LayoutTransform sections of the editor (see Figure 28-14).

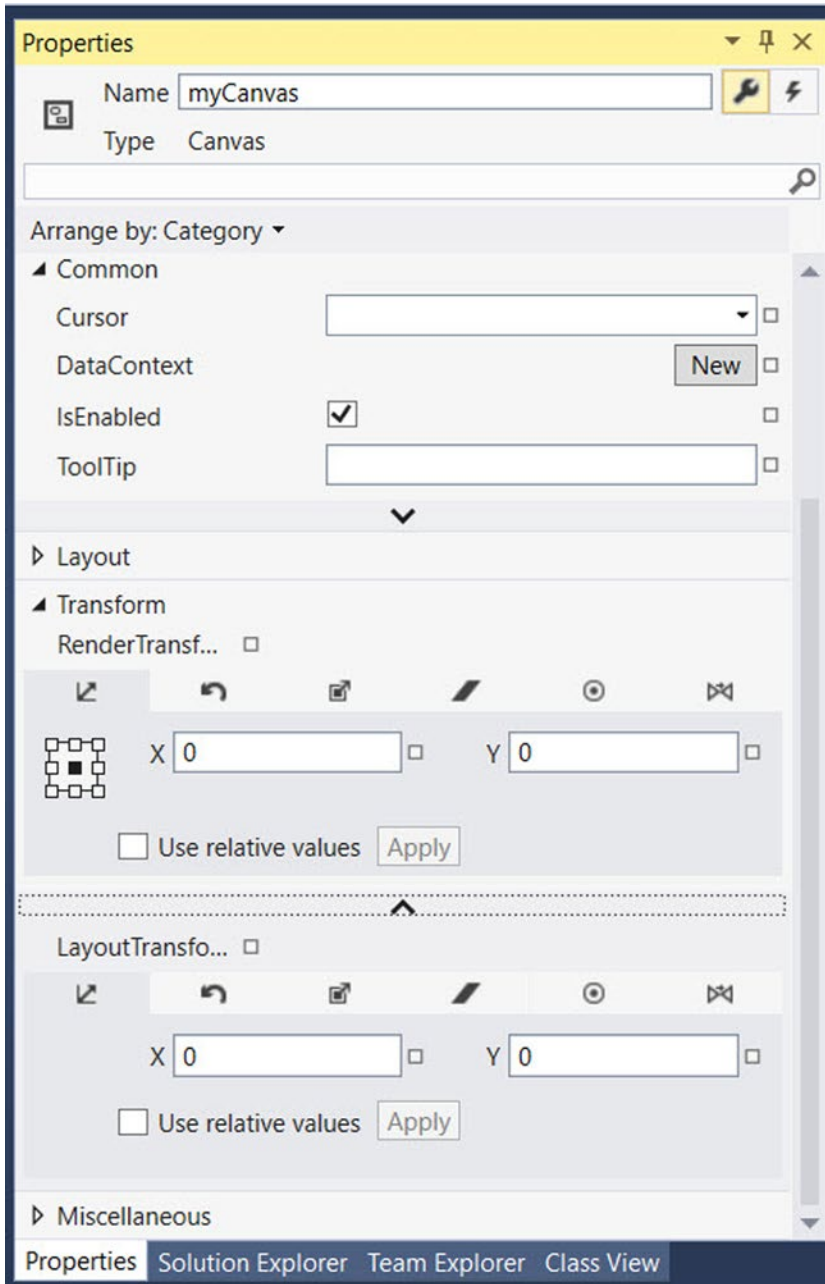

Figure 28-14. The Transform editor

Similar to the Brushes section, the Transform section provides a number of tabs to configure various types of graphical transformation to the currently selected item. Table 28-6 describes each transformation option, listed in the order of evaluating each tab left to right.

Table 28-6. Blend Transformation Options

| Transformation Option | Meaning in Life |
|-----------------------|---|
| Translate | Allows you to offset the location of an item on an X, Y position. |
| Rotate | Allows you to rotate an item on a 360-degree angle. |
| Scale | Allows you to grow or shrink an item by a factor in the X and Y directions. |
| Skew | Allows you to skew the bounding box containing the selected item by a factor in the X and Y directions. |
| Center Point | When you rotate or flip an object, the item moves relative to a fixed point, called the object's center point. By default, an object's center point is located at the object's center; however, this transformation allows you to change an object's center point in order to rotate or flip the object around a different point. |
| Flip | Flips a selected item based on an X or Y center point. |

I suggest you test each of these transformations using your custom shape as a target (just press Ctrl+Z to undo the previous operation). Like many other aspects of the Transform Properties panel, each transformation section has a unique set of configuration options, which should become fairly understandable as you tinker. For example, the Skew transform editor allows you to set the X and Y skew values, the Flip transform editor allows you to flip on the X or Y axis, and so forth.

Transforming the Canvas in Code

The implementation of each Click event handler will be more or less the same. You will configure a transformation object and assign it to the myCanvas object. Then, when you run the application, you can click a button to see the result of the applied transformation. Here is the complete code for each event handler (notice that you are setting the `LayoutTransform` property so the shape data remains positioned relative to the parent container):

```
private void btnFlip_Click(object sender, System.Windows.RoutedEventArgs e)
{
    myCanvas.LayoutTransform = new ScaleTransform(-1, 1);
}

private void btnRotate_Click(object sender, System.Windows.RoutedEventArgs e)
{
    myCanvas.LayoutTransform = new RotateTransform(180);
}

private void btnSkew_Click(object sender, System.Windows.RoutedEventArgs e)
{
    myCanvas.LayoutTransform = new SkewTransform(40, -20);
}
```

■ **Source Code** The FunWithTransformations project can be found in the Chapter 28 subdirectory.

Rendering Graphical Data Using Drawings and Geometries

While the Shape types allow you to generate any sort of interactive two-dimensional surface, they entail quite a bit of memory overhead due to their rich inheritance chain. And though the Path class can help remove some of this overhead using contained geometries (rather than a large collection of other shapes), WPF provides a sophisticated drawing and geometry programming interface that renders even more lightweight 2D vector images.

The entry point into this API is the abstract `System.Windows.Media.Drawing` class (in `PresentationCore.dll`), which on its own does little more than define a bounding rectangle to hold the rendering. Figure 28-15 shows that the inheritance chain of the Drawing class is significantly more lightweight than Shape, given that neither `UIElement` nor `FrameworkElement` is in the inheritance chain.

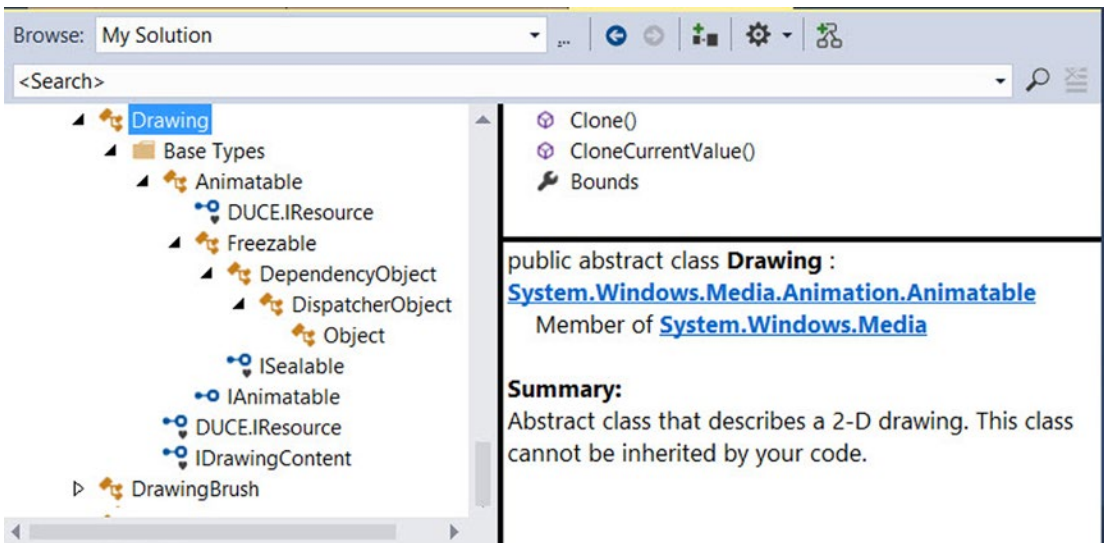

Figure 28-15. The `Drawing` class is more lightweight than `Shape`

WPF provides various classes that extend `Drawing`, each of which represents a particular way of drawing the content, as described in Table 28-7.

Table 28-7. WPF Drawing-Derived Types

| Type | Meaning in Life |
|-----------------|--|
| DrawingGroup | Used to combine a collection of separate Drawing-derived objects into a single composite rendering. |
| GeometryDrawing | Used to render 2D shapes in a very lightweight manner. |
| GlyphRunDrawing | Used to render textual data using WPF graphical rendering services. |
| ImageDrawing | Used to render an image file, or geometry set, into a bounding rectangle. |
| VideoDrawing | Used to play an audio file or video file. This type can only be fully exploited using procedural code. If you would like to play videos via XAML, the MediaPlayer type is a better choice. |

Because they are more lightweight, Drawing-derived types do not have intrinsic support for handling input events, as they are not `UIElement`s or `FrameworkElement`s (although it is possible to programmatically perform hit-testing logic).

Another key difference between Drawing-derived types and Shape-derived types is that Drawing-derived types have no ability to render themselves, as they do not derive from `UIElement`! Rather, derived types must be placed within a hosting object (specifically, `DrawingImage`, `DrawingBrush`, or `DrawingVisual`) to display their content.

`DrawingImage` allows you to place drawing and geometries inside a WPF Image control, which typically is used to display data from an external file. `DrawingBrush` allows you to build a brush based on a drawing and its geometries, in order to set a property that requires a brush. Finally, `DrawingVisual` is used only in the “visual” layer of graphical rendering, which is driven completely via C# code.

Although using drawings is a bit more complex than using simple shapes, this decoupling of graphical composition from graphical rendering makes the Drawing-derived types much more lightweight than the Shape-derived types, while still retaining key services.

Building a DrawingBrush Using Geometries

Earlier in this chapter, you filled a `Path` with a group of geometries, like so:

```
<Path Fill = "Orange" Stroke = "Blue" StrokeThickness = "3">
  <Path.Data>
    <GeometryGroup>
      <EllipseGeometry Center = "75,70"
        RadiusX = "30" RadiusY = "30" />
      <RectangleGeometry Rect = "25,55 100 30" />
      <LineGeometry StartPoint="0,0" EndPoint="70,30" />
      <LineGeometry StartPoint="70,30" EndPoint="0,30" />
    </GeometryGroup>
  </Path.Data>
</Path>
```

By doing this, you gain interactivity from Path but are still fairly lightweight given your geometries. However, if you want to render the same output and have no need for any (out-of-the-box) interactivity, you can place the same <GeometryGroup> inside a DrawingBrush, like this:

```
<DrawingBrush>
  <DrawingBrush.Drawing>
    <GeometryDrawing>
      <GeometryDrawing.Geometry>
        <GeometryGroup>
          <EllipseGeometry Center = "75,70"
            RadiusX = "30" RadiusY = "30" />
          <RectangleGeometry Rect = "25,55 100 30" />
          <LineGeometry StartPoint="0,0" EndPoint="70,30" />
          <LineGeometry StartPoint="70,30" EndPoint="0,30" />
        </GeometryGroup>
      </GeometryDrawing.Geometry>
      <!-- A custom pen to draw the borders. -->
      <GeometryDrawing.Pen>
        <Pen Brush="Blue" Thickness="3"/>
      </GeometryDrawing.Pen>
      <!-- A custom brush to fill the interior. -->
      <GeometryDrawing.Brush>
        <SolidColorBrush Color="Orange"/>
      </GeometryDrawing.Brush>
    </GeometryDrawing>
  </DrawingBrush.Drawing>
</DrawingBrush>
```

When you place a group of geometries into a DrawingBrush, you also need to establish the Pen object used to draw the boundaries because you no longer inherit a Stroke property from the Shape base class. Here, you created a <Pen> with the same settings used in the Stroke and StrokeThickness values of the previous Path example.

Furthermore, since you no longer inherit a Fill property from Shape, you also need to use property element syntax to define a brush object to use for the <DrawingGeometry>, which here is a solid colored orange brush, just like the previous Path settings.

Painting with the DrawingBrush

Now that you have a DrawingBrush, you can use it to set the value of any property requiring a brush object. For example, if you are authoring this markup in Xaml, you could use property-element syntax to paint your drawing over the entire surface of a Page, like so:

```
<Page
  xmlns="http://schemas.microsoft.com/winfx/2006/xaml/presentation"
  xmlns:x="http://schemas.microsoft.com/winfx/2006/xaml">

  <Page.Background>
    <!-- Same DrawingBrush as seen above. -->
    <DrawingBrush>
      ...
    </DrawingBrush>
  </Page.Background>
</Page>
```

Or, you can use this `<DrawingBrush>` to set a different brush-compatible property, such as the `Background` property of a `Button`:

```
<Page
  xmlns="http://schemas.microsoft.com/winfx/2006/xaml/presentation"
  xmlns:x="http://schemas.microsoft.com/winfx/2006/xaml">

  <Button Height="100" Width="100">
    <Button.Background>
      <!-- Same DrawingBrush as seen above. -->
      <DrawingBrush>
        ...
      </DrawingBrush>
    </Button.Background>
  </Button>

</Page>
```

No matter which brush-compatible property you set with your custom `<DrawingBrush>`, the bottom line is you are rendering a 2D vector image with much less overhead than the same 2D image rendered with shapes.

Containing Drawing Types in a `DrawingImage`

The `DrawingImage` type allows you to plug your drawing geometry into a WPF `<Image>` control. Consider the following:

```
<Page
  xmlns="http://schemas.microsoft.com/winfx/2006/xaml/presentation"
  xmlns:x="http://schemas.microsoft.com/winfx/2006/xaml">
  <Image Height="100" Width="100">
    <Image.Source>
      <DrawingImage>
        <DrawingImage.Drawing>
          <GeometryDrawing>
            <GeometryDrawing.Geometry>
              <GeometryGroup>
                <EllipseGeometry Center = "75,70"
                  RadiusX = "30" RadiusY = "30" />
                <RectangleGeometry Rect = "25,55 100 30" />
                <LineGeometry StartPoint="0,0" EndPoint="70,30" />
                <LineGeometry StartPoint="70,30" EndPoint="0,30" />
              </GeometryGroup>
            </GeometryDrawing.Geometry>
          </GeometryDrawing>
          <!-- A custom pen to draw the borders. -->
          <GeometryDrawing.Pen>
            <Pen Brush="Blue" Thickness="3"/>
          </GeometryDrawing.Pen>
        </DrawingImage.Drawing>
      </DrawingImage>
    </Image.Source>
  </Image>
</Page>
```



```

        <!-- A custom brush to fill the interior. -->
        <GeometryDrawing.Brush>
            <SolidColorBrush Color="Orange"/>
        </GeometryDrawing.Brush>
    </GeometryDrawing>
</DrawingImage.Drawing>
</DrawingImage>
</Image.Source>
</Image>
</Page>

```

In this case, your `<GeometryDrawing>` has been placed into a `<DrawingImage>`, rather than a `<DrawingBrush>`. Using this `<DrawingImage>`, you can set the `Source` property of the `Image` control.

Working with Vector Images

As you might agree, it would be quite challenging for a graphic artist to create a complex vector-based image using the tools and techniques provided by Visual Studio. Graphic artists have their own set of tools that can produce amazing vector graphics. Neither Visual Studio nor its companion Expression Blend for Visual Studio have that type of design power. Before you can import vector images into WPF application, they must be converted into Path expressions. At that point, you can program against the generated object model using Visual Studio.

■ **Note** Previous editions of this text demonstrated a software package named Expression Design. Expression Design was one of the products within Expression Studio, and unfortunately the whole suite is no longer being updated. While you can still access the software if you have a MSDN subscription, in this edition of this book I am using open source software and a printer trick to convert vector graphics to the required path information for XAML rendering. The image being used (`laser_sign.svg`) as well as the exported path (`laser_sign.xaml`) data are included in the Chapter 28 folder of the download files. The image is originally from Wikipedia, located in this article: https://en.wikipedia.org/wiki/Hazard_symbol.

Converting a Sample Vector Graphic File into XAML

Before you can import complex graphical data (such as vector graphics) into a WPF application, you need to convert the graphics into path data. As an example of how to do this, start with a sample `.svg` image file, such as the laser sign referenced in the preceding note. Then download and install an open source tool called Inkscape (located at www.inkscape.org). Using Inkscape, open the `laser_sign.svg` file from the chapter download. You should see something that resembles Figure 28-16.

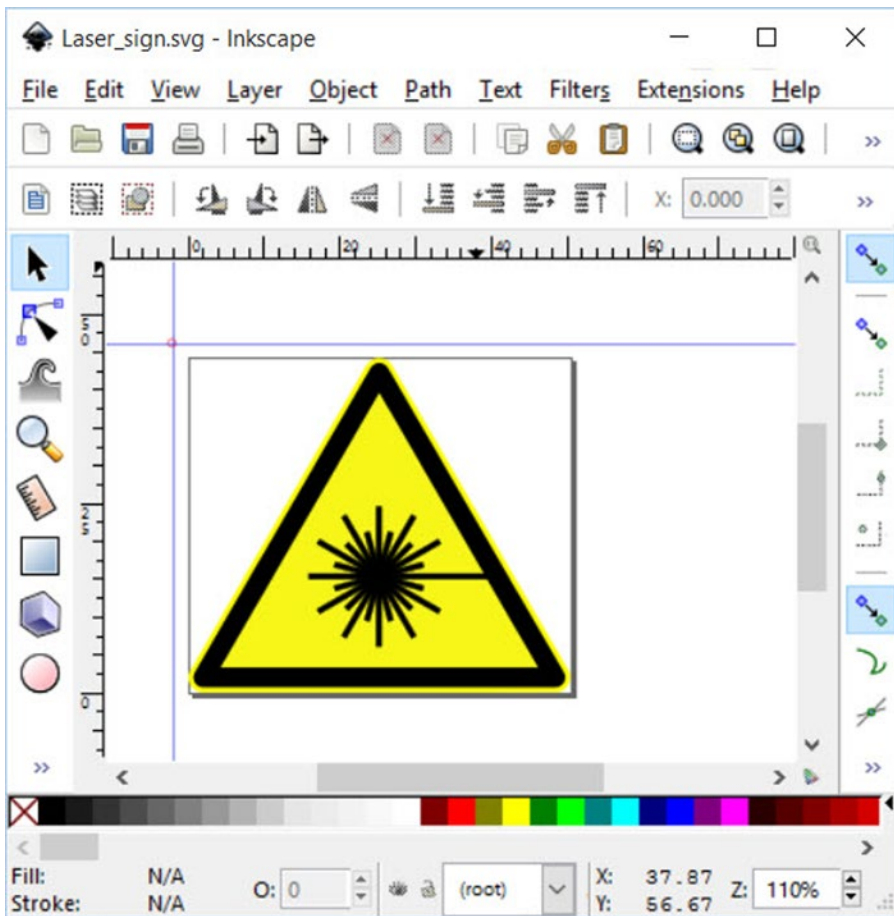

Figure 28-16. The laser sign sample graphic in Inkscape

■ **Note** ImageMagick (www.ImageMagick.org) is also a very good free image handling tool. Unfortunately, the trick that you will learn shortly doesn't work on Windows 10 with ImageMagick.

The next steps will seem a bit odd at first, but once you get over the oddity, it is a simple way to convert vector images to XAML. When you have the image the way you want it, select the File ► Print menu option. Next, select the Microsoft XPS Document Writer as the printer target, and then click Print (see Figure 28-17). On the next screen, enter a file name and select where the file should be saved, then click Save. Now you have a complete *.xps (or *.oxps) file.

■ **Note** Depending on a number of variables with your system configuration, the generated file will have either the .xps or .oxps extension. Either way, the process works the same.

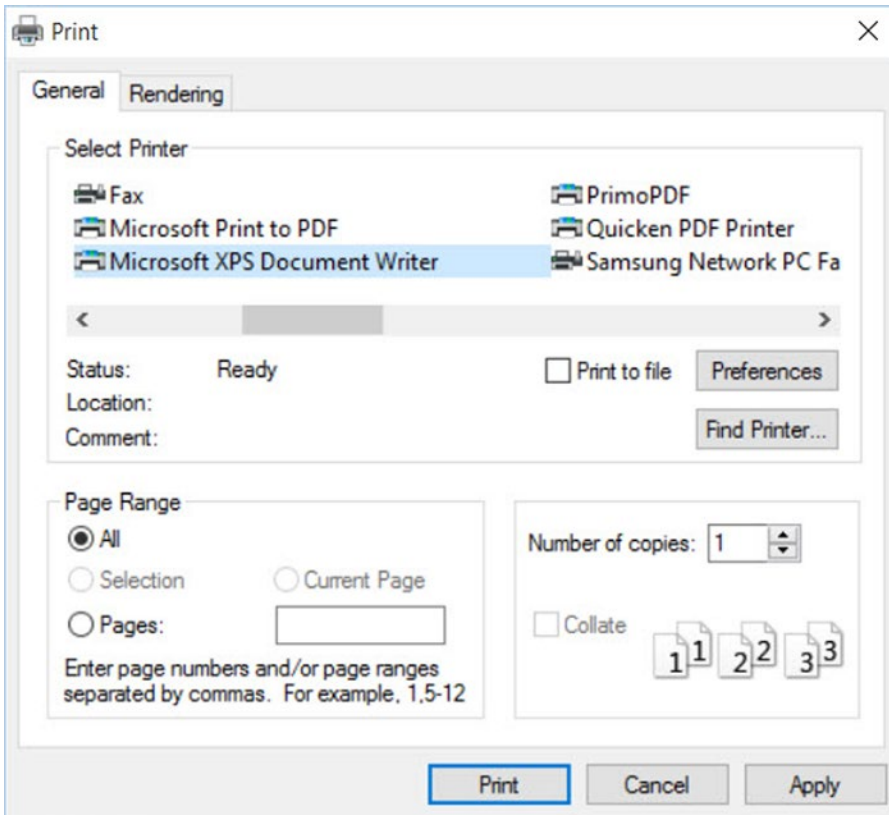

Figure 28-17. Printing the graphic to the Microsoft XPS Document Printer

The *.xps and *.oxps formats are actually a zip file. Rename the extension of the file to .zip and you can open the file in File Explorer (or 7-zip, or your favorite archive tool). You will see that it contains the hierarchy shown in Figure 28-18.

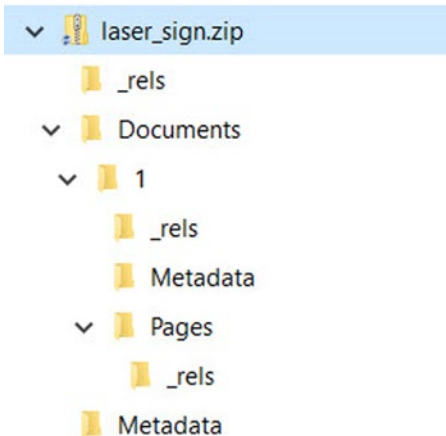

Figure 28-18. The folder hierarchy of the printed XPS file

The file that you need is in the Pages directory (Documents/1/Pages) and is named 1.fpage. Open the file with a text editor and copy everything except the <FixedPage> open and closing tags. The path data can then be copied into the MyXAMLPad (that you wrote earlier), and placed inside a Canvas in the main Window. Click the View XAML button, and you will see your vector graphic reproduced in XAML! Figure 28-19 shows the rendered image using MyXamlPad.

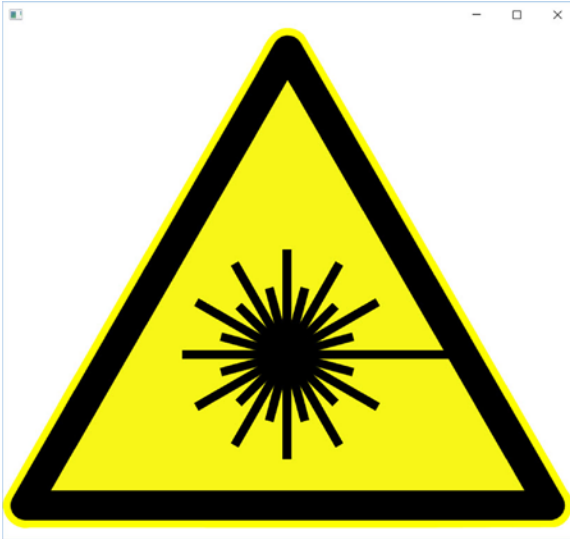

Figure 28-19. The vector graphic rendered in XAML

Importing the Graphical Data into a WPF Project

At this point, create a new WPF Application named InteractiveLaserSign. Resize the dimensions of the Window to the following height and width, and delete the initial Grid control and replace it with a Canvas:

```
<Window x:Class="InteractiveTeddyBear.MainWindow"
        xmlns="http://schemas.microsoft.com/winfx/2006/xaml/presentation"
        xmlns:x="http://schemas.microsoft.com/winfx/2006/xaml"
        Title="MainWindow" Height="625" Width="675">
  <Canvas>
</Canvas>
</Window>
```

Copy the entire XAML from MyXamlPad (excluding the outer Canvas) and paste into the MainWindow Canvas control. View the Window in design mode, and you will see the sign reproduced in your application!

If you view the Document Outline, you will see that each XAML element is present and accounted for. The goal here is to locate a couple of the lines and give each item a name. While you could manually hunt for the correct objects (which would be very tedious), a better way is to click these items using the visual designer. This will automatically highlight the correct node in the Document Outline editor. This particular graphic uses two objects to make up each line, so click one of the lines in the graphic and see where it is represented in the document editor. Check the object above and below to discover which pair are matched,

and then name them `Line1_1` and `Line1_2`. Repeat this process with another line, and name the pair `Line2_1` and `Line2_2`. To make the interaction easier, change the `Brush` for `Line1_1` and `Line2_1` to another color besides black by selecting the object in the Document Outline, selecting `Brush` in the properties, and changing the color (just like you've done earlier in this chapter).

Interacting with the Sign

Now you will handle click events for the objects. Select `Line1_1` and `Line2_1` on the designer, activate the Events area of the Properties window, and enter the event handler names as required. For the current example, handle the `MouseLeftButtonDown` event for each object, specifying a unique method name each time.

Here is some simple C# code that will change the look and feel of each object when clicked (if you don't feel like typing all the code seen here, you can simply add a `MessageBox.Show()` statement for each handler, and display a fitting message):

```
private void Line1_1_MouseLeftButtonDown(object sender, MouseButtonEventArgs e)
{
    // Change the color when clicked.
    Line1_2.Fill = new SolidColorBrush(Colors.Red);
}

private void Line2_1_MouseLeftButtonDown(object sender, MouseButtonEventArgs e)
{
    // Blur when clicked.
    System.Windows.Media.Effects.BlurEffect blur =
        new System.Windows.Media.Effects.BlurEffect();
    blur.Radius = 10;
    Line2_1.Effect = blur;
}
```

Now, run your application. Click the lines to see the effects. The results should resemble [Figure 28-20](#).

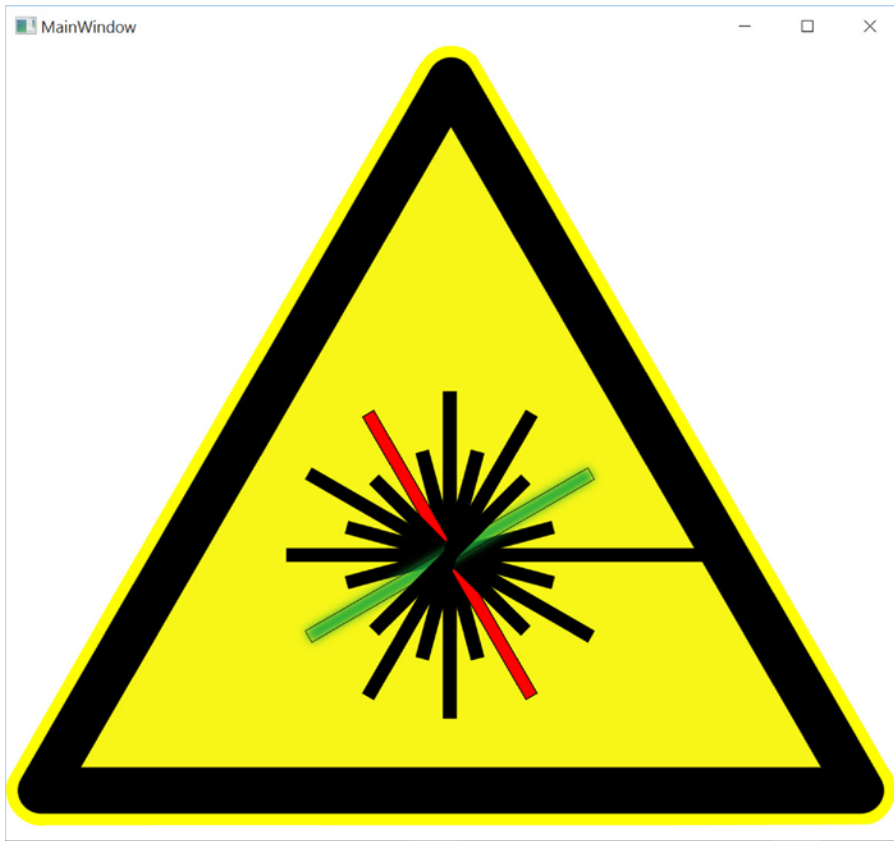

Figure 28-20. *Interacting with complex graphical data*

You now understand the process of generating Path data for complex graphics and how to interact with the graphical data in code. As you might agree, the ability for professional graphic artists to generate complex graphical data and export the data as XAML is extremely powerful. Once the graphical data has been generated, developers can import the markup and program against the object model.

■ **Source Code** The InteractiveLaserSign project can be found in the [Chapter 28](#) subdirectory.

Rendering Graphical Data Using the Visual Layer

The final option for rendering graphical data with WPF is termed the *visual layer*. As mentioned, you can only gain access to this layer through code (it is not XAML-friendly). While a vast majority of your WPF applications will work just fine using shapes, drawings, and geometries, the visual layer does provide the fastest possible way to render huge amounts of graphical data. Oddly, this very low-level graphical layer can also be useful when you need to render a single image over a very large area. For example, if you need to fill the background of a window with a plain, static image, the visual layer is the fastest way to do so. It can also be useful if you need to change between window backgrounds very quickly, based on user input or whatnot.

We won't spend too much time delving into the details of this aspect of WPF programming, but let's build a small sample program to illustrate the basics.

The Visual Base Class and Derived Child Classes

The abstract `System.Windows.Media.Visual` class type supplies a minimal set of services (rendering, hit-testing, transformations) to render graphics, but it does not provide support for additional nonvisual services, which can lead to code bloat (input events, layout services, styles, and data binding). Notice the simple inheritance chain of the `Visual` type shown in Figure 28-21.

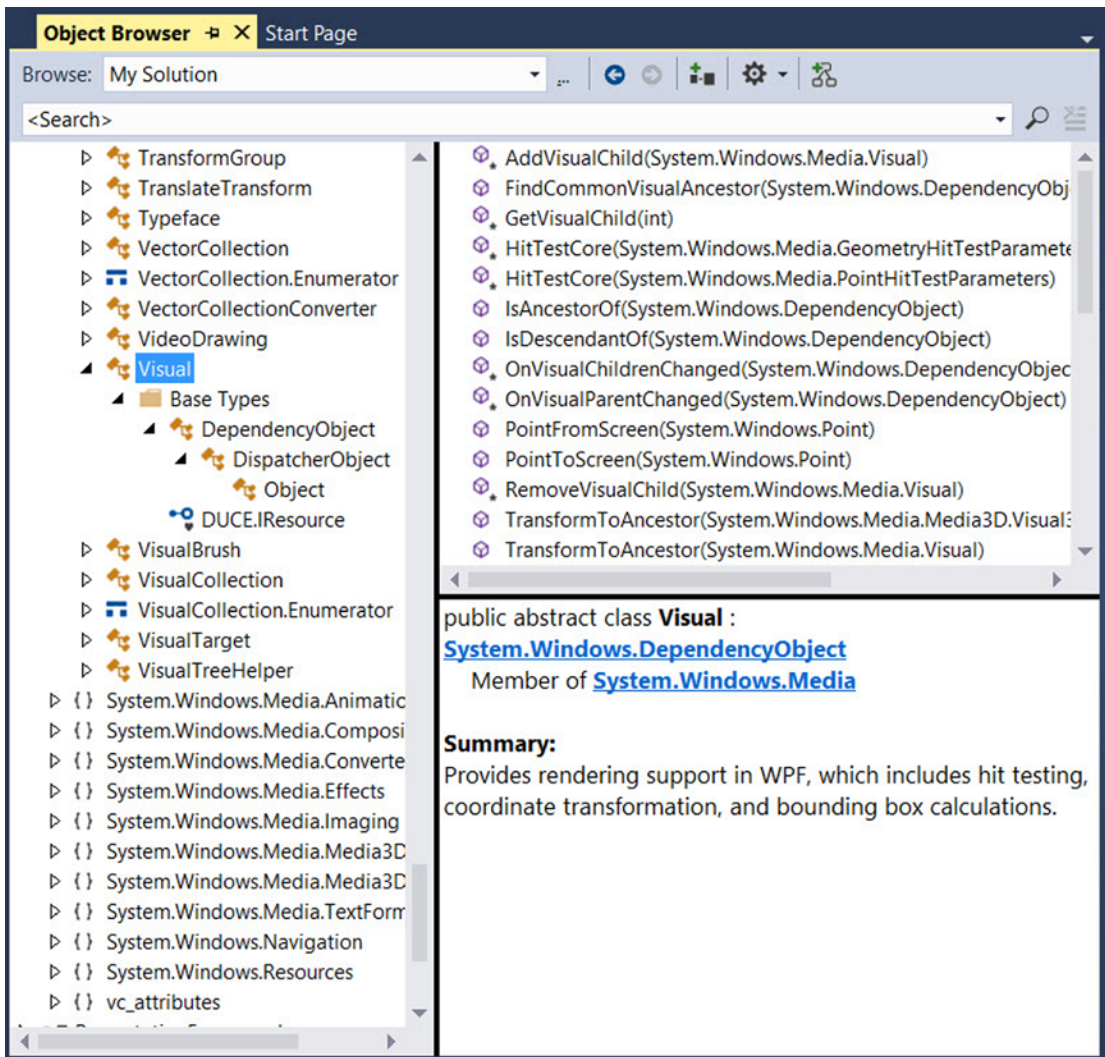

Figure 28-21. The `Visual` type provides basic hit-testing, coordinate transformation, and bounding box calculations

Given that `Visual` is an abstract base class, you need to use one of the derived types to perform actual rendering operations. WPF provides a handful of subclasses, including `DrawingVisual`, `Viewport3DVisual`, and `ContainerVisual`.

In this example, you will focus only on `DrawingVisual`, a lightweight drawing class that is used to render shapes, images, or text.

A First Look at Using the `DrawingVisual` Class

To render data onto a surface using `DrawingVisual`, you need to take the following basic steps:

- Obtain a `DrawingContext` object from the `DrawingVisual` class.
- Use the `DrawingContext` to render the graphical data.

These two steps represent the bare minimum necessary for rendering some data to a surface. However, if you want the graphical data you've rendered to be responsive to hit-testing calculations (which would be important for adding user interactivity), you will also need to perform these additional steps:

- Update the logical and visual trees maintained by the container upon which you are rendering.
- Override two virtual methods from the `FrameworkElement` class, allowing the container to obtain the visual data you have created.

You will examine these final two steps in a bit. First, to illustrate how you can use the `DrawingVisual` class to render 2D data, create a new WPF application with Visual Studio named `RenderingWithVisuals`. Your first goal is to use a `DrawingVisual` to dynamically assign data to a WPF `Image` control. Begin by updating the XAML of your window, like so:

```
<Window x:Class="RenderingWithVisuals.MainWindow"
    xmlns="http://schemas.microsoft.com/winfx/2006/xaml/presentation"
    xmlns:x="http://schemas.microsoft.com/winfx/2006/xaml"
    Title="Fun with the Visual Layer" Height="350" Width="525"
    Loaded="Window_Loaded" WindowStartupLocation="CenterScreen">
  <StackPanel Background="AliceBlue" Name="myStackPanel">
    <Image Name="myImage" Height="80"/>
  </StackPanel>
</Window>
```

Notice that your `<Image>` control does not yet have a `Source` value because that will happen at runtime. Also notice that you are handling the `Loaded` event of the window, which will do the work of building the in-memory graphical data, using a `DrawingBrush` object. Here is the implementation of the `Loaded` event handler:

```
private void Window_Loaded(object sender, RoutedEventArgs e)
{
    const int TextFontSize = 30;

    // Make a System.Windows.Media.FormattedText object.
    FormattedText text = new FormattedText("Hello Visual Layer!",
        new System.Globalization.CultureInfo("en-us"),
        FlowDirection.LeftToRight,
        new Typeface(this.FontFamily, FontStyles.Italic,
            FontWeights.DemiBold, FontStretches.UltraExpanded),
        TextFontSize,
        Brushes.Green);
```



```

// Create a DrawingVisual, and obtain the DrawingContext.
DrawingVisual drawingVisual = new DrawingVisual();
using(DrawingContext drawingContext = drawingVisual.RenderOpen())
{
    // Now, call any of the methods of DrawingContext to render data.
    drawingContext.DrawRoundedRectangle(Brushes.Yellow, new Pen(Brushes.Black, 5),
        new Rect(5, 5, 450, 100), 20, 20);
    drawingContext.DrawText(text, new Point(20, 20));
}

// Dynamically make a bitmap, using the data in the DrawingVisual.
RenderTargetBitmap bmp = new RenderTargetBitmap(500, 100, 100, 90,
    PixelFormats.Pbgra32);
bmp.Render(drawingVisual);

// Set the source of the Image control!
myImage.Source = bmp;
}

```

This code introduces a number of new WPF classes, which I will briefly comment on here (be sure to check the .NET Framework 4.6 SDK documentation for full details if you are interested). The method begins by creating a new `FormattedText` object that represents the textual portion of the in-memory image you are constructing. As you can see, the constructor allows you to specify numerous attributes such as font size, font family, foreground color, and the text itself.

Next, you obtain the necessary `DrawingContext` object via a call to `RenderOpen()` on the `DrawingVisual` instance. Here, you are rendering a colored, rounded rectangle into the `DrawingVisual`, followed by your formatted text. In both cases, you are placing the graphical data into the `DrawingVisual` using hard-coded values, which is not necessarily a great idea for production, but is fine for this simple test.

■ **Note** Be sure to look up the `DrawingContext` class within the .NET Framework 4.6 SDK documentation to view all rendering members. If you have worked with the Windows Forms Graphics object in the past, `DrawingContext` should look very similar.

The last few statements map the `DrawingVisual` into a `RenderTargetBitmap` object, which is a member of the `System.Windows.Media.Imaging` namespace. This class will take a visual object and transform it into an in-memory bitmap image. After this point, you set the `Source` property of the `Image` control, and sure enough, you will see the output in Figure 28-22.

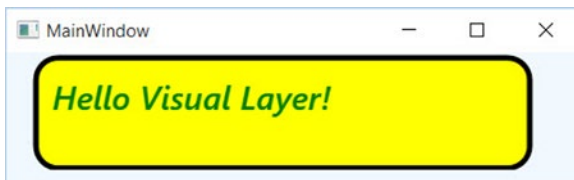

Figure 28-22. Using the visual layer to render an in-memory bitmap

■ **Note** The `System.Windows.Media.Imaging` namespace contains a number of additional encoding classes that let you save the in-memory `RenderTargetBitmap` object to a physical file in a variety of formats. Check out the `JpegBitmapEncoder` class (and friends) for more information.

Rendering Visual Data to a Custom Layout Manager

While it is interesting to use `DrawingVisual` to paint onto the background of a WPF control, it is perhaps more common to build a custom layout manager (`Grid`, `StackPanel`, `Canvas`, etc.) that uses the visual layer internally to render its content. After you have created such a custom layout manager, you can plug it into a normal `Window` (or `Page`, or `UserControl`) and have a part of the UI using a highly optimized rendering agent, while the noncritical aspects of the hosting `Window` use shapes and drawings for the remainder of the graphical data.

If you don't require the extra functionality provided by a dedicated layout manager, you could opt to simply extend `FrameworkElement`, which does have the necessary infrastructure to also contain visual items. To illustrate how this could be done, insert a new class to your project named `CustomVisualFrameworkElement`. Extend this class from `FrameworkElement` and import the `System.Windows`, `System.Windows.Input`, and `System.Windows.Media` namespaces.

This class will maintain a member variable of type `VisualCollection`, which contains two fixed `DrawingVisual` objects (of course, you could add new members to this collection via a mouse operation, but this example will keep it simple). Update your class with the following new functionality:

```
class CustomVisualFrameworkElement : FrameworkElement
{
    // A collection of all the visuals we are building.
    VisualCollection theVisuals;

    public CustomVisualFrameworkElement()
    {
        // Fill the VisualCollection with a few DrawingVisual objects.
        // The ctor arg represents the owner of the visuals.
        theVisuals = new VisualCollection(this);
        theVisuals.Add(AddRect());
        theVisuals.Add(AddCircle());
    }
    private Visual AddCircle()
    {
        DrawingVisual drawingVisual = new DrawingVisual();

        // Retrieve the DrawingContext in order to create new drawing content.
        using (DrawingContext drawingContext = drawingVisual.RenderOpen())
        {
            // Create a circle and draw it in the DrawingContext.
            Rect rect = new Rect(new Point(160, 100), new Size(320, 80));
            drawingContext.DrawEllipse(Brushes.DarkBlue, null, new Point(70, 90), 40, 50);
        }
        return drawingVisual;
    }
}
```

```

private Visual AddRect()
{
    DrawingVisual drawingVisual = new DrawingVisual();
    using (DrawingContext drawingContext = drawingVisual.RenderOpen())
    {
        Rect rect = new Rect(new Point(160, 100), new Size(320, 80));
        drawingContext.DrawRectangle(Brushes.Tomato, null, rect);
    }
    return drawingVisual;
}
}

```

Now, before you can use this custom `FrameworkElement` in your `Window`, you must override two key virtual methods mentioned previously, both of which are called internally by WPF during the rendering process. The `GetVisualChild()` method returns a child at the specified index from the collection of child elements. The read-only `VisualChildrenCount` property returns the number of visual child elements within this visual collection. Both methods are easy to implement because you can delegate the real work to the `VisualCollection` member variable.

```

protected override int VisualChildrenCount
{
    get { return theVisuals.Count; }
}

protected override Visual GetVisualChild(int index)
{
    // Value must be greater than zero, so do a sanity check.
    if (index < 0 || index >= theVisuals.Count)
    {
        throw new ArgumentOutOfRangeException();
    }
    return theVisuals[index];
}

```

You now have just enough functionality to test your custom class. Update the XAML description of the `Window` to add one of your `CustomVisualFrameworkElement` objects to the existing `StackPanel`. Doing so will require you to build a custom XML namespace that maps to your .NET namespace.

```

<Window x:Class="RenderingWithVisuals.MainWindow"
    xmlns="http://schemas.microsoft.com/winfx/2006/xaml/presentation"
    xmlns:x="http://schemas.microsoft.com/winfx/2006/xaml"
    xmlns:custom="clr-namespace:RenderingWithVisuals"
    Title="Fun with the Visual Layer" Height="350" Width="525"
    Loaded="Window_Loaded" WindowStartupLocation="CenterScreen">
    <StackPanel Background="AliceBlue" Name="myStackPanel">
        <Image Name="myImage" Height="80"/>
        <custom:CustomVisualFrameworkElement/>
    </StackPanel>
</Window>

```

If all is well, you should see something similar to Figure 28-23 when you run your program.

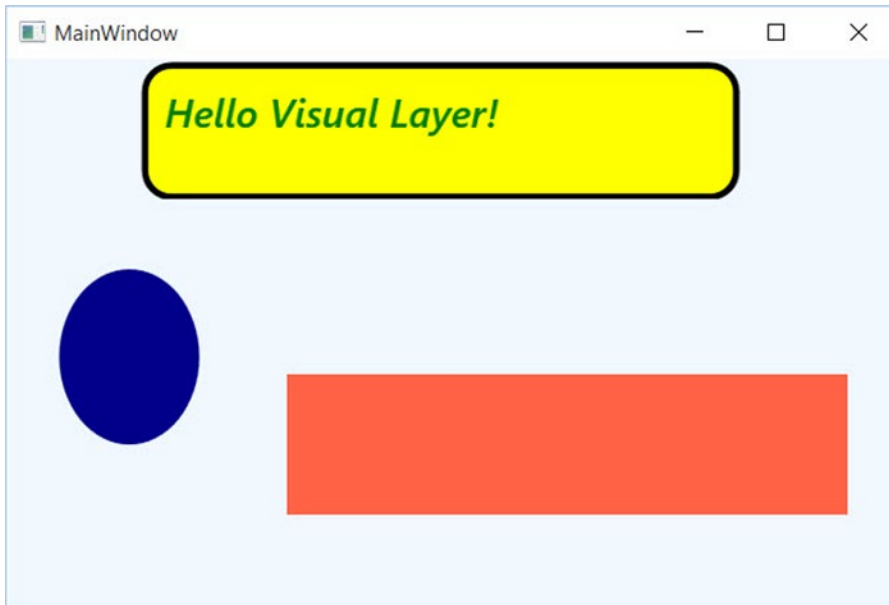

Figure 28-23. Using the visual layer to render data to a custom `FrameworkElement`

Responding to Hit-Test Operations

Because `DrawingVisual` does not have any of the infrastructure of `UIElement` or `FrameworkElement`, you will need to programmatically add in the ability to calculate hit-test operations. Thankfully, this is fairly easy to do in the visual layer because of the concept of *logical* and *visual* trees. As it turns out, when you author a blob of XAML, you are essentially building a logical tree of elements. However, behind every logical tree is a much richer description known as the visual tree, which contains lower-level rendering instructions.

Chapter 29 will delve into these trees in more detail but for now, just understand that until you register your custom visuals with these data structures, you will not be able to perform hit-testing operations. Luckily, the `VisualCollection` container does this on your behalf (which explains why you needed to pass in a reference to the custom `FrameworkElement` as a constructor argument).

First, update the `CustomVisualFrameworkElement` class to handle the `MouseDown` event in the class constructor using standard C# syntax, like so:

```
this.MouseDown += MyVisualHost_MouseDown;
```

The implementation of this handler will call the `VisualTreeHelper.HitTest()` method to see whether the mouse is within the boundaries of one of the rendered visuals. To do this, you specify as a parameter to `HitTest()` a `HitTestResultCallback` delegate that will perform the calculations. If you click on a visual, you will toggle between a skewed rendering of the visual and the original rendering. Add the following methods to your `CustomVisualFrameworkElement` class:

```
void MyVisualHost_MouseDown(object sender, MouseButtonEventArgs e)
{
    // Figure out where the user clicked.
    Point pt = e.GetPosition((UIElement)sender);

    // Call helper function via delegate to see if we clicked on a visual.
    VisualTreeHelper.HitTest(this, null,
        new HitTestResultCallback(myCallback), new PointHitTestParameters(pt));
}

public HitTestResultBehavior myCallback(HitTestResult result)
{
    // Toggle between a skewed rendering and normal rendering,
    // if a visual was clicked.
    if (result.VisualHit.GetType() == typeof(DrawingVisual))
    {
        if (((DrawingVisual)result.VisualHit).Transform == null)
        {
            ((DrawingVisual)result.VisualHit).Transform = new SkewTransform(7, 7);
        }
        else
        {
            ((DrawingVisual)result.VisualHit).Transform = null;
        }
    }

    // Tell HitTest() to stop drilling into the visual tree.
    return HitTestResultBehavior.Stop;
}
```

Now, run your program once again. You should now be able to click either rendered visual and see the transformation in action! While this is just a very simple example of working with the visual layer of WPF, remember that you make use of the same brushes, transformations, pens, and layout managers as you would when working with XAML. As a result, you already know quite a bit about working with this Visual-derived classes.

■ **Source Code** The `RenderingWithVisuals` project can be found in the [Chapter 28](#) subdirectory.

That wraps up your investigation of the graphical rendering services of Windows Presentation Foundation. While you learned a number of interesting topics, the reality is that you have only scratched the surface of WPF's graphical capabilities. I will leave it in your hands to dig deeper into the topics of shapes, drawings, brushes, transformations, and visuals (and, to be sure, you will see some additional details of these topics in the remaining WPF chapters).

Summary

Because Windows Presentation Foundation is such a graphically intensive GUI API, it comes as no surprise that we are given a number of ways to render graphical output. This chapter began by examining each of three ways a WPF application can do so (shapes, drawings, and visuals) and discussed various rendering primitives such as brushes, pens, and transformations.

Remember that when you need to build interactive 2D renderings, shapes make the process very simple. However, static, non-interactive renderings can be rendered in a more optimal manner by using drawings and geometries, while the visual layer (accessible only in code) gives you maximum control and performance.

CHAPTER 29



WPF Resources, Animations, Styles, and Templates

This chapter introduces you to three important (and interrelated) topics that will deepen your understanding of the Windows Presentation Foundation (WPF) API. The first order of business is to learn the role of *logical resources*. As you will see, the logical resource (also known as an *object resource*) system is a way to name and refer to commonly used objects within a WPF application. While logical resources are often authored in XAML, they can also be defined in procedural code.

Next, you will learn how to define, execute, and control an animation sequence. Despite what you might think, WPF animations are not limited to video game or multimedia applications. Under the WPF API, animations can be as subtle as making a button appear to glow when it receives focus, or expanding the size of a selected row in a `DataGrid`. Understanding animations is a key aspect of building custom control templates (as you'll see in later in this chapter).

You'll then explore the role of WPF styles and templates. Much like a web page that uses CSS or the ASP.NET theme engine, a WPF application can define a common look and feel for a set of controls. You can define these styles in markup and store them as object resources for later use, and you can also apply them dynamically at runtime. The final example will teach you how to build custom control templates.

Understanding the WPF Resource System

Your first task is to examine the topic of embedding and accessing application resources. WPF supports two flavors of resources. The first is a *binary resource*, and this category typically includes items most programmers consider a resource in the traditional sense (embedded image files or sound clips, icons used by the application, and so on).

The second flavor, termed *object resources* or *logical resources*, represents a named .NET object that can be packaged and reused throughout the application. While any .NET object can be packaged as an object resource, logical resources are particularly helpful when working with graphical data of any sort, given that you can define commonly used graphic primitives (brushes, pens, animations, etc.) and refer to them when required.

Working with Binary Resources

Before we get to the topic of object resources, let's quickly examine how to package up *binary resources* such as icons or image files (e.g., company logos or images for an animation) into your applications. If you'd like to follow along, create a new WPF application named `BinaryResourcesApp` using Visual Studio. Update the

markup for your initial window to handle the Window Loaded event and to use a DockPanel as the layout root, like so:

```
<Window x:Class="BinaryResourcesApp.MainWindow"
  xmlns="http://schemas.microsoft.com/winfx/2006/xaml/presentation"
  xmlns:x="http://schemas.microsoft.com/winfx/2006/xaml"
  xmlns:d="http://schemas.microsoft.com/expression/blend/2008"
  xmlns:mc="http://schemas.openxmlformats.org/markup-compatibility/2006"
  xmlns:local="clr-namespace:BinaryResourcesApp"
  mc:Ignorable="d"
  Title="Fun with Binary Resources" Height="500" Width="649"
  Loaded="MainWindow_OnLoaded">

  <DockPanel LastChildFill="True">
  </DockPanel>

</Window>
```

Now, let's say your application needs to display one of three image files inside part of the window, based on user input. The WPF Image control can be used to not only display a typical image file (*.bmp, *.gif, *.ico, *.jpg, *.png, *.wdp, or *.tiff) but also data in a DrawingImage (as you saw in Chapter 28). You might build a UI for your window that supports a DockPanel containing a simple toolbar with Next and Previous buttons. Below this toolbar you can place an Image control, which currently does not have a value set to the Source property, like so:

```
<Window x:Class="BinaryResourcesApp.MainWindow"
  xmlns="http://schemas.microsoft.com/winfx/2006/xaml/presentation"
  xmlns:x="http://schemas.microsoft.com/winfx/2006/xaml"
  xmlns:d="http://schemas.microsoft.com/expression/blend/2008"
  xmlns:mc="http://schemas.openxmlformats.org/markup-compatibility/2006"
  xmlns:local="clr-namespace:BinaryResourcesApp"
  mc:Ignorable="d"
  Title="Fun with Binary Resources" Height="500" Width="649">
  Loaded="MainWindow_OnLoaded">

  <DockPanel LastChildFill="True">
    <ToolBar Height="60" Name="picturePickerToolBar" DockPanel.Dock="Top">
      <Button x:Name="btnPreviousImage" Height="40" Width="100" BorderBrush="Black"
        Margin="5" Content="Previous" Click="btnPreviousImage_Click"/>
      <Button x:Name="btnNextImage" Height="40" Width="100" BorderBrush="Black"
        Margin="5" Content="Next" Click="btnNextImage_Click"/>
    </ToolBar>

    <!-- We will fill this Image in code. -->
    <Border BorderThickness="2" BorderBrush="Green">
      <Image x:Name="imageHolder" Stretch="Fill" />
    </Border>
  </DockPanel>

</Window>
```

Please note that the Click event has been handled for each Button object. Assuming you have used the IDE to handle these events, you will have three empty methods in your C# code file. So, how can you code the Click event handlers to cycle through the image data? More importantly, do you want to have the image data located on the user's hard drive or embedded in your compiled assembly? Let's examine your options.

Including Loose Resource Files in a Project

Let's assume you want to ship your image files as a set of loose files in a subdirectory of the application install path. Using the Solution Explorer window of Visual Studio, you can right-click your project node and select the Add ► New Folder menu option to create such a subdirectory, which you should call Images.

Now, when you right-click this folder, you can select the Add ► Existing Item menu option to copy the image files into the new subdirectory. In the downloadable source code for this project, you will find three image files named Deer.jpg, Dogs.jpg, and Welcome.jpg that you can include in this project, or you can add three image files of your choice. Figure 29-1 shows the current setup.

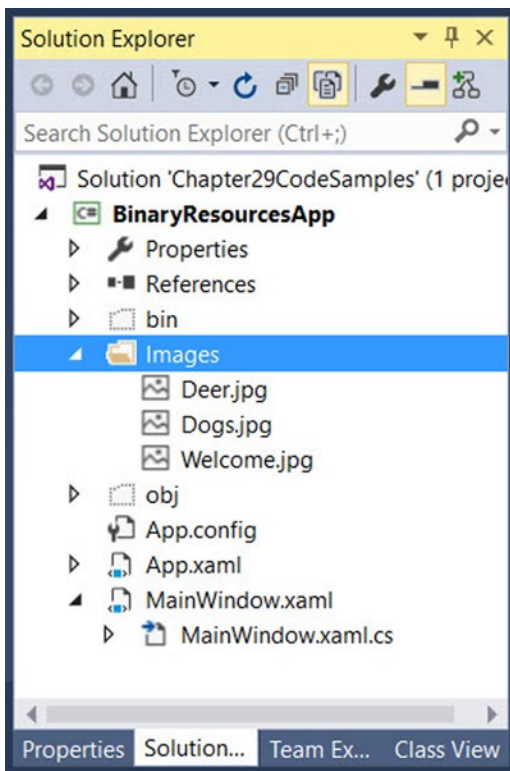

Figure 29-1. A new subdirectory that contains image data in your WPF project

Configuring the Loose Resources

When you want Visual Studio to copy project content to your output directory, you need to adjust a few settings using the Properties window. To ensure that the content of your `\Images` folder is copied to the `\bin\Debug` folder, begin by selecting each image in the Solution Explorer. Now, with these images still selected, use the Properties window to set the Build Action property to Content, and the Copy to Output Directory property to Copy always (see Figure 29-2).

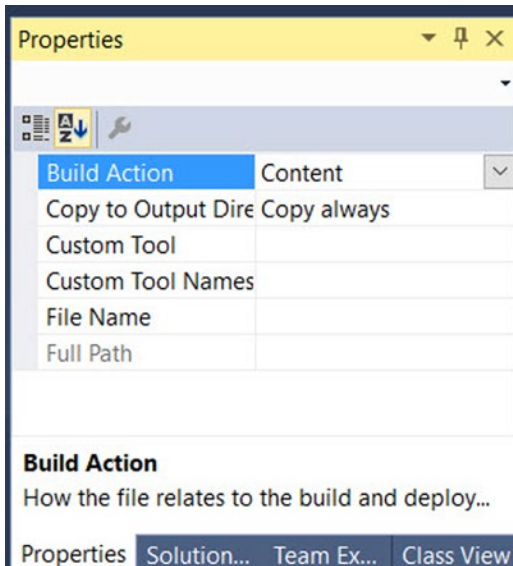

Figure 29-2. Configuring the image data to be copied to your output directory

■ **Note** You could also select Copy if Newer, which will save you time if you're building large projects with a lot of content. For this example, Copy always works just fine.

If you recompile your program, you can now click the Show all Files button of the Solution Explorer and view the copied Image folder under your `\bin\Debug` directory (you might need to click the Refresh button). See Figure 29-3.

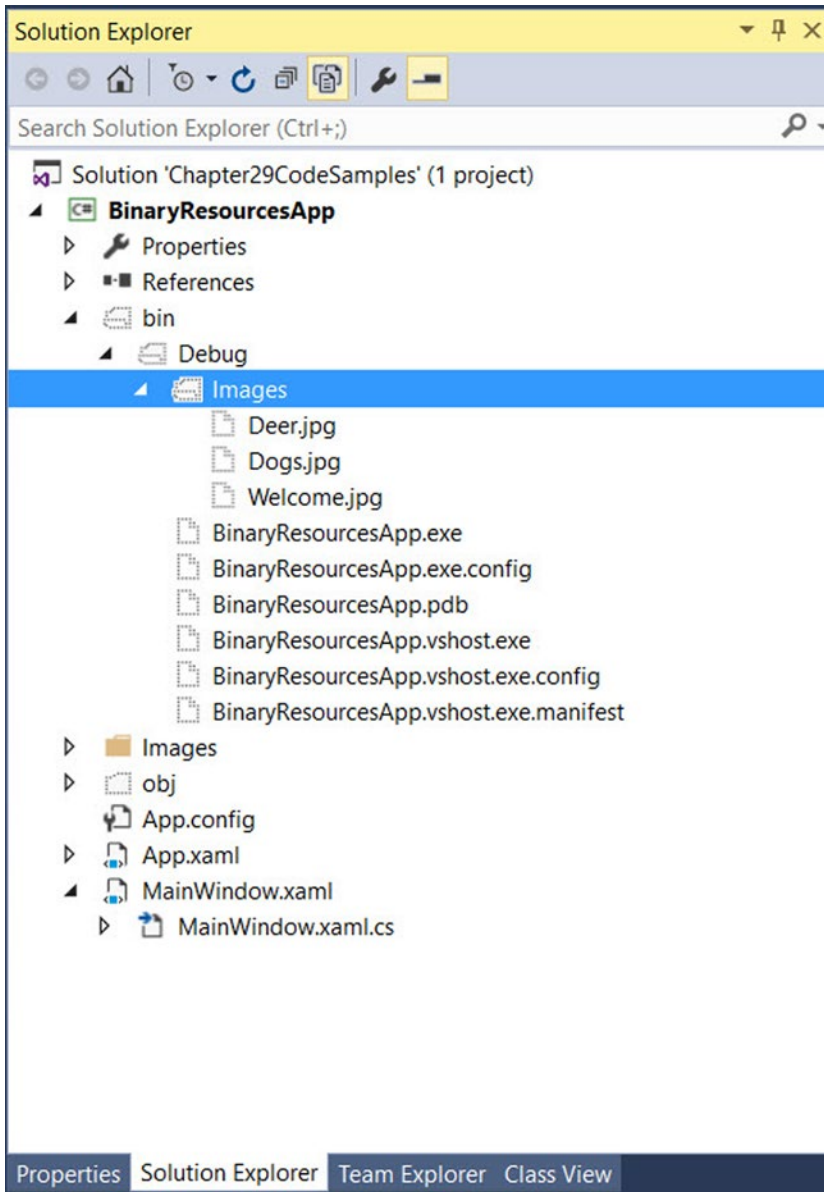

Figure 29-3. The copied data

Programmatically Loading an Image

WPF provides a class named `BitmapImage`, which is part of the `System.Windows.Media.Imaging` namespace. This class allows you to load data from an image file whose location is represented by a `System.Uri` object. It's now time to handle the `Loaded` event of your window, filling a `List<T>` of `BitmapImage`s like so:

```
public partial class MainWindow : Window
{
    // A List of BitmapImage files.
    List<BitmapImage> _images = new List<BitmapImage>();

    // Current position in the list.
    private int _currImage = 0;
    private const int MAX_IMAGES = 2;
    private void MainWindow_OnLoaded(object sender, RoutedEventArgs e)
    {
        try
        {
            string path = Environment.CurrentDirectory;

            // Load these images when the window loads.
            _images.Add(new BitmapImage(new Uri($"{path}\Images\Deer.jpg")));
            _images.Add(new BitmapImage(new Uri($"{path}\Images\Dogs.jpg")));
            _images.Add(new BitmapImage(new Uri($"{path}\Images\Welcome.jpg")));

            // Show first image in the List<>.
            imageHolder.Source = _images[_currImage];
        }
        catch (Exception ex)
        {
            MessageBox.Show(ex.Message);
        }
    }
    ...
}
```

Notice that this class also defines an `int` member variable (`_currImage`) that will allow the `Click` event handlers to loop through each item in the `List<T>` and display it in the `Image` control by setting the `Source` property. (Here, your `Loaded` event handler sets the `Source` property to the first image in the `List<T>`.) In addition, your `MAX_IMAGES` constant will let you test for upper and lower limits as you iterate over the list. Here are the `Click` handlers that do exactly this:

```
private void btnPreviousImage_Click(object sender, RoutedEventArgs e)
{
    if (--_currImage < 0)
        _currImage = MAX_IMAGES;
    imageHolder.Source = _images[_currImage];
}
```

```
private void btnNextImage_Click(object sender, RoutedEventArgs e)
{
    if (++_currImage > MAX_IMAGES)
        _currImage = 0;
    imageHolder.Source = _images[_currImage];
}
```

At this point, you can run your program and flip through each picture.

Embedding Application Resources

If you'd rather configure your image files to be compiled directly into your .NET assembly as binary resources, select the image files in Solution Explorer (in the `\Images` folder, not in the `\bin\Debug\Images` folder). Then change the Build Action property to Resource, and the Copy to Output Directory property to Do not copy (see Figure 29-4).

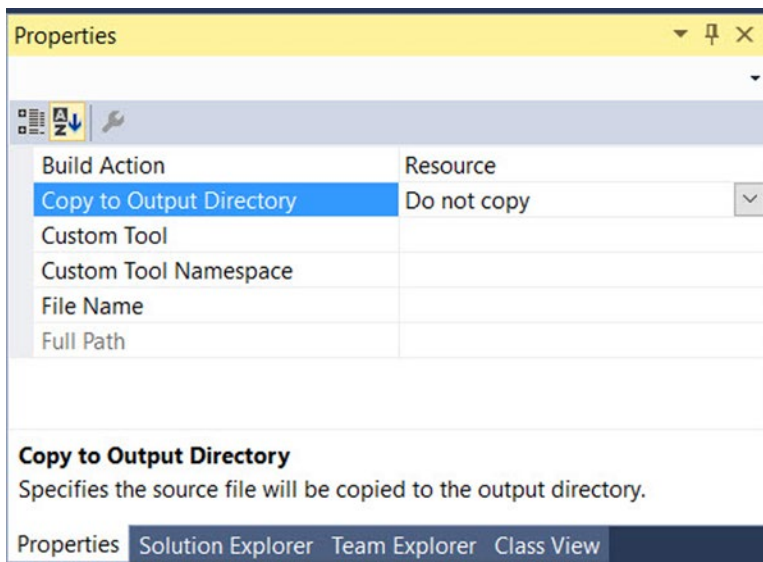

Figure 29-4. Configuring the images to be embedded resources

Now, using Visual Studio's Build menu, select the Clean Solution option to wipe out the current contents of `\bin\Debug\Images`, and then rebuild your project. Refresh the Solution Explorer, and observe the absence of data in your `\bin\Debug\Images` directory. With the current build options, your graphical data is no longer copied to the output folder and is now embedded within the assembly itself.

With this adjustment, you now need to modify your code to load these images by extracting them from the compiled assembly:

```
private void MainWindow_OnLoaded(object sender, RoutedEventArgs e)
{
    try
    {
        _images.Add(new BitmapImage(new Uri(@"/Images/Deer.jpg", UriKind.Relative)));
        _images.Add(new BitmapImage(new Uri(@"/Images/Dogs.jpg", UriKind.Relative)));
    }
}
```

```

    _images.Add(new BitmapImage(new Uri(@"/Images/Welcome.jpg", UriKind.Relative)));
    imageHolder.Source = _images[_currImage];
}
catch (Exception ex)
{
    MessageBox.Show(ex.Message);
}
}

```

In this case, you no longer need to determine the installation path and can simply list the resources by name, which takes into account the name of the original subdirectory. Also notice, when you create your `Uri` objects, you specify a `UriKind` value of `Relative`. In any case, at this point your executable is a stand-alone entity that can be run from any location on the machine, as all compiled data is within the binary. Figure 29-5 shows the completed application.

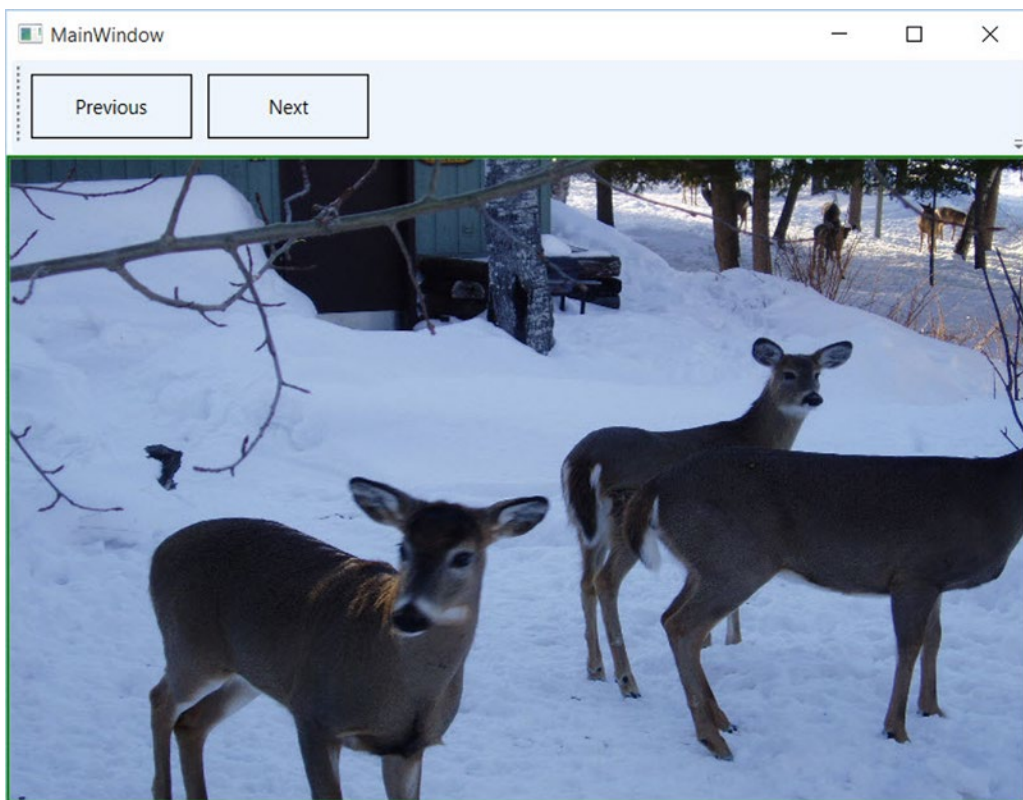

Figure 29-5. Your simple picture viewer

■ **Source Code** The `BinaryResourcesApp` can be found in the [Chapter 29](#) subdirectory.

Working with Object (Logical) Resources

When you are building a WPF application, it is very common to define a blob of XAML to use in multiple locations within a window, or perhaps across multiple windows or projects. For example, say you have created the *perfect* linear gradient brush, which consists of ten lines of markup. Now, you want to use that brush as the background color for every Button control in the project (which consists of eight windows) for a total of 16 Buttons.

The worst thing you could do is to copy and paste the XAML to every control. Clearly, this would be a nightmare to maintain, as you would need to make numerous changes anytime you wanted to tweak the look and feel of the brush.

Thankfully, *object resources* allow you to define a blob of XAML, give it a name, and store it in a fitting dictionary for later use. Like a binary resource, object resources are often compiled into the assembly that requires them. However, you don't need to tinker with the Build Action property to do so. As long as you place your XAML into the correct location, the compiler will take care of the rest.

Working with object resources is a big part of WPF development. As you will see, object resources can be far more complex than a custom brush. You can define a XAML-based animation, a 3D rendering, a custom control style, data template, control template, and more, and package each one as a reusable resource.

The Role of the Resources Property

As mentioned, object resources must be placed in a fitting dictionary object in order to be used across an application. As it stands, every descendant of FrameworkElement supports a Resources property. This property encapsulates a ResourceDictionary object that contains the defined object resources. The ResourceDictionary can hold any type of item because it operates on System.Object types and may be manipulated via XAML or procedural code.

In WPF, all controls, Windows, Pages (used when building navigation applications or XBAP programs), and UserControls extend FrameworkElement, so just about all widgets provide access to a ResourceDictionary. Furthermore, the Application class, while not extending FrameworkElement, supports an identically named Resources property for the same purpose.

Defining Window-Wide Resources

To begin exploring the role of object resources, create a new WPF application named ObjectResourcesApp using Visual Studio and change the initial Grid to a horizontally aligned StackPanel layout manager. Into this StackPanel, define two Button controls like so (you really don't need much to illustrate the role of object resources, so this will do):

```
<Window x:Class="ObjectResourcesApp.MainWindow"
  xmlns="http://schemas.microsoft.com/winfx/2006/xaml/presentation"
  xmlns:x="http://schemas.microsoft.com/winfx/2006/xaml"
  xmlns:d="http://schemas.microsoft.com/expression/blend/2008"
  xmlns:mc="http://schemas.openxmlformats.org/markup-compatibility/2006"
  xmlns:local="clr-namespace:ObjectResourcesApp"
  mc:Ignorable="d"
  Title="Fun with Object Resources" Height="350" Width="525">

  <StackPanel Orientation="Horizontal">
    <Button Margin="25" Height="200" Width="200" Content="OK" FontSize="20"/>
    <Button Margin="25" Height="200" Width="200" Content="Cancel" FontSize="20"/>
  </StackPanel>

</Window>
```

Now, select the OK button and set the Background color property to a custom brush type using the integrated brush editor (discussed in Chapter 28). After you've done so, notice how the brush is embedded within the scope of the <Button> and </Button> tags, as shown here:

```
<Button Margin="25" Height="200" Width="200" Content="OK" FontSize="20">
  <Button.Background>
    <RadialGradientBrush>
      <GradientStop Color="#FFC44EC4" Offset="0" />
      <GradientStop Color="#FF829CEB" Offset="1" />
      <GradientStop Color="#FF793879" Offset="0.669" />
    </RadialGradientBrush>
  </Button.Background>
</Button>
```

To allow the Cancel button to use this brush as well, you should promote the scope of your <RadialGradientBrush> to a parent element's resource dictionary. For example, if you move it to the <StackPanel>, both buttons can use the same brush because they are child elements of the layout manager. Even better, you could package the brush into the resource dictionary of the window itself, so all aspects of the window's content (nested panels, etc.) can freely make use of it.

When you need to define a resource, you use the property element syntax to set the Resources property of the owner. You also give the resource item an x:Key value, which will be used by other parts of the window when they want to refer to the object resource. Be aware that x:Key and x:Name are not the same! The x:Name attribute allows you to gain access to the object as a member variable in your code file, while the x:Key attribute allows you to refer to an item in a resource dictionary.

Visual Studio allows you to promote a resource to a higher scope using its respective Properties window. To do so, first identify the property that has the complex object you want to package as a resource (the Background property, in this example). Next to the property is a small white square that, when clicked, will open a pop-up menu. From it, select the Convert to New Resource option (see Figure 29-6).

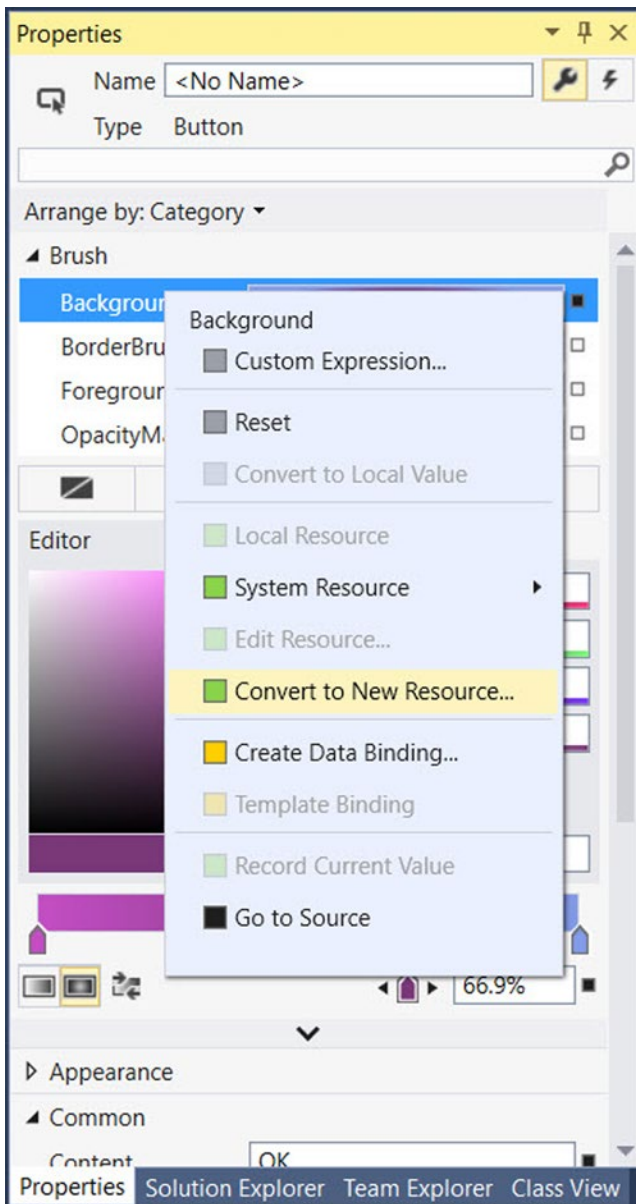

Figure 29-6. Moving a complex object into a resource container

You are asked to name your resource (`myBrush`) and specify where to place it. For this example, leave the default selection of the current document (see Figure 29-7).

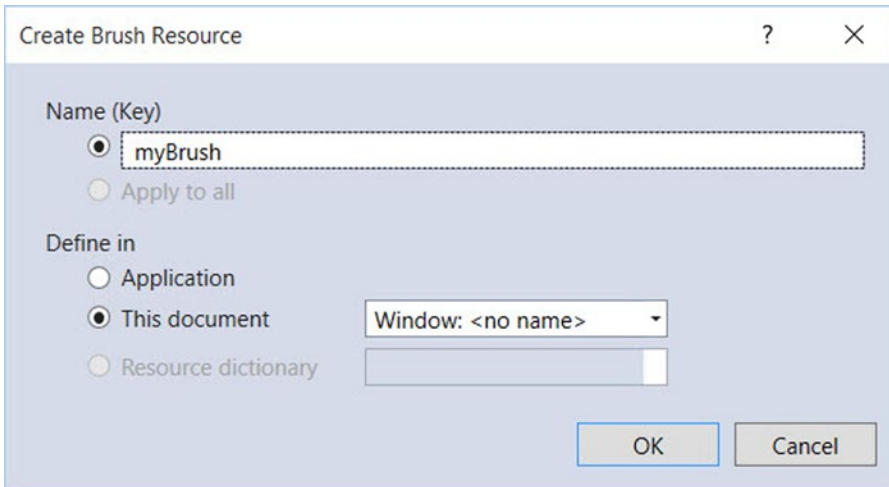

Figure 29-7. Naming the object resource

When you're done, the markup will be restructured like this:

```
<Window x:Class="ObjectResourcesApp.MainWindow"
  xmlns="http://schemas.microsoft.com/winfx/2006/xaml/presentation"
  xmlns:x="http://schemas.microsoft.com/winfx/2006/xaml"
  xmlns:d="http://schemas.microsoft.com/expression/blend/2008"
  xmlns:mc="http://schemas.openxmlformats.org/markup-compatibility/2006"
  xmlns:local="clr-namespace:ObjectResourcesApp"
  mc:Ignorable="d"
  Title="Fun with Object Resources" Height="350" Width="525">

  <Window.Resources>
    <RadialGradientBrush x:Key="myBrush">
      <GradientStop Color="#FFC44EC4" Offset="0" />
      <GradientStop Color="#FF829CEB" Offset="1" />
      <GradientStop Color="#FF793879" Offset="0.669" />
    </RadialGradientBrush>
  </Window.Resources>

  <StackPanel Orientation="Horizontal">
    <Button Margin="25" Height="200" Width="200" Content="OK"
      FontSize="20" Background="{DynamicResource myBrush}"/>
    <Button Margin="25" Height="200" Width="200" Content="Cancel" FontSize="20"/>
  </StackPanel>
</Window>
```

Notice the new `<Window.Resources>` scope, which now contains the `RadialGradientBrush` object, which has a key value of `myBrush`. The Create Resource wizard creates the new resource as a `DynamicResource`. You will learn about `DynamicResources` later in the text, but for now, change it to a `StaticResource`, like this:

```
<Button Margin="25" Height="200" Width="200" Content="OK"
        FontSize="20" Background="{StaticResource myBrush}"/>
<Button Margin="25" Height="200" Width="200" Content="Cancel" FontSize="20"/>
```

The {StaticResource} Markup Extension

The other change that took place when you extracted your object resource was that the property that was the target of the extraction (again, `Background`) now makes use of the `{StaticResource}` markup extension. As you can see, the key name is specified as an argument. Now, if the `Cancel` button opts to use the same brush to paint its background, it is free to do so. Or, if the `Cancel` button had some complex content, any sub-element of that `Button` could also use the window-level resource, such as the `Fill` property of an `Ellipse`.

```
<StackPanel Orientation="Horizontal">
  <Button Margin="25" Height="200" Width="200" Content="OK" FontSize="20"
          Background="{StaticResource myBrush}">
  </Button>

  <Button Margin="25" Height="200" Width="200" FontSize="20">
    <StackPanel>
      <Label HorizontalAlignment="Center" Content="No Way!"/>
      <Ellipse Height="100" Width="100" Fill="{StaticResource myBrush}"/>
    </StackPanel>
  </Button>
</StackPanel>
```

The {DynamicResource} Markup Extension

It is also possible for a property to use the `{DynamicResource}` markup extension when connecting to a keyed resource. To understand the difference, name your `OK` button `btnOK` and handle the `Click` event. In this event handler, use the `Resources` property to obtain the custom brush, and then change some aspect of it, like so:

```
private void btnOK_Click(object sender, RoutedEventArgs e)
{
    // Get the brush and make a change.
    var b = (RadialGradientBrush)Resources["myBrush"];
    b.GradientStops[1] = new GradientStop(Colors.Black, 0.0);
}
```

■ **Note** You are using the `Resources` indexer to locate a resource by name here. Be aware, however, that this will throw a runtime exception if the resource can't be found. You could also use the `TryFindResource()` method, which will not throw a runtime error; it will simply return `null` if the specified resource can't be located.

If you run this application and click the OK button, you will see that the brush's change is accounted for and each button updates to render the modified brush. However, what if you completely changed the type of brush specified by the `myBrush` key? For example,

```
private void btnOK_Click(object sender, RoutedEventArgs e)
{
    // Put a totally new brush into the myBrush slot.
    Resources["myBrush"] = new SolidColorBrush(Colors.Red);
}
```

This time, when you click the button, neither updates as expected. This is because the `{StaticResource}` markup extension applies the resource only once and stays “connected” to the original object during the life of the application. However, if you change each occurrence of `{StaticResource}` to `{DynamicResource}` in your markup, you find your custom brush has been replaced with the expected solid red brush.

Essentially, the `{DynamicResource}` markup extension is able to detect whether the underlying keyed object has been replaced with a new object. As you might guess, this requires some extra runtime infrastructure, so you should typically stick to using `{StaticResource}` unless you know you have an object resource that will be swapped with a different object at runtime, and you want all items using that resource to be informed.

Application-Level Resources

When you have object resources in a window's resource dictionary, all items in the window are free to make use of it, but other windows in the application cannot. Give your Cancel button a name of `btnCancel` and handle the Click event. Insert a new window into your current project (named `TestWindow.xaml`) that contains a single Button, which, when clicked, will close the window.

```
public partial class TestWindow : Window
{
    public TestWindow()
    {
        InitializeComponent();
    }

    private void btnClose_Click(object sender, RoutedEventArgs e)
    {
        Close();
    }
}
```

Now, in the Click handler of the Cancel button on your first window, just load and display this new window, like so:

```
private void btnCancel_Click(object sender, RoutedEventArgs e)
{
    var w = new TestWindow();
    w.Owner = this;
    w.WindowStartupLocation = WindowStartupLocation.CenterOwner;
    w.ShowDialog();
}
```

So, if the new window wants to use `myBrush`, it currently won't be able to because it is not within the correct "scope." The solution is to define the object resource at the application level, rather than at the level of a specific window. There is no way to automate this within Visual Studio, so simply cut the current brush object out of the `<Windows.Resources>` scope, and place it in the `<Application.Resources>` scope in your `App.xaml` file.

```
<Application x:Class="ObjectResourcesApp.App"
  xmlns="http://schemas.microsoft.com/winfx/2006/xaml/presentation"
  xmlns:x="http://schemas.microsoft.com/winfx/2006/xaml"
  xmlns:local="clr-namespace:ObjectResourcesApp"
  StartupUri="MainWindow.xaml">

  <Application.Resources>
    <RadialGradientBrush x:Key="myBrush">
      <GradientStop Color="#FFC44EC4" Offset="0" />
      <GradientStop Color="#FF829CEB" Offset="1" />
      <GradientStop Color="#FF793879" Offset="0.669" />
    </RadialGradientBrush>
  </Application.Resources>

</Application>
```

Now your `TestWindow` is free to use this same brush to paint its background. If you want to find the `Background` property for this new window, click the `Brush Resources` tab (all the way on the right) to view your application-level resources (see Figure 29-8).

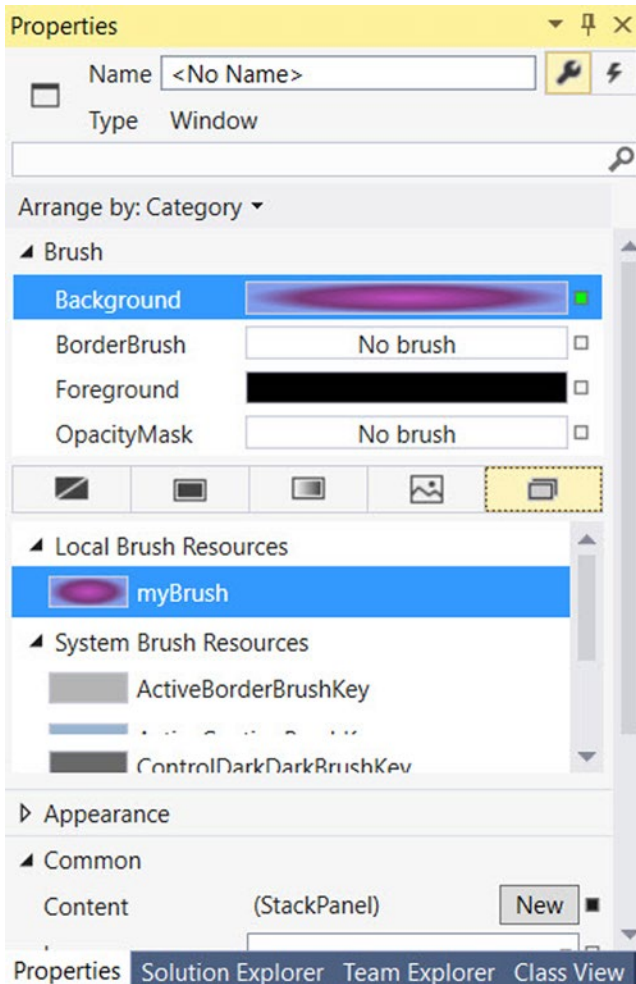

Figure 29-8. Applying application-level resources

Defining Merged Resource Dictionaries

Application-level resources are a good starting point, but what if you need to define a set of complex (or not so complex) resources that need to be reused across multiple WPF projects? In this case, you want to define what is known as a *merged resource dictionary*. This is nothing more than a .xaml file that contains a collection of object resources. A single project can have as many of these files as required (one for brushes, one for animations, and so forth), each of which can be inserted using the Add New Item dialog box activated via the Project menu (see Figure 29-9).

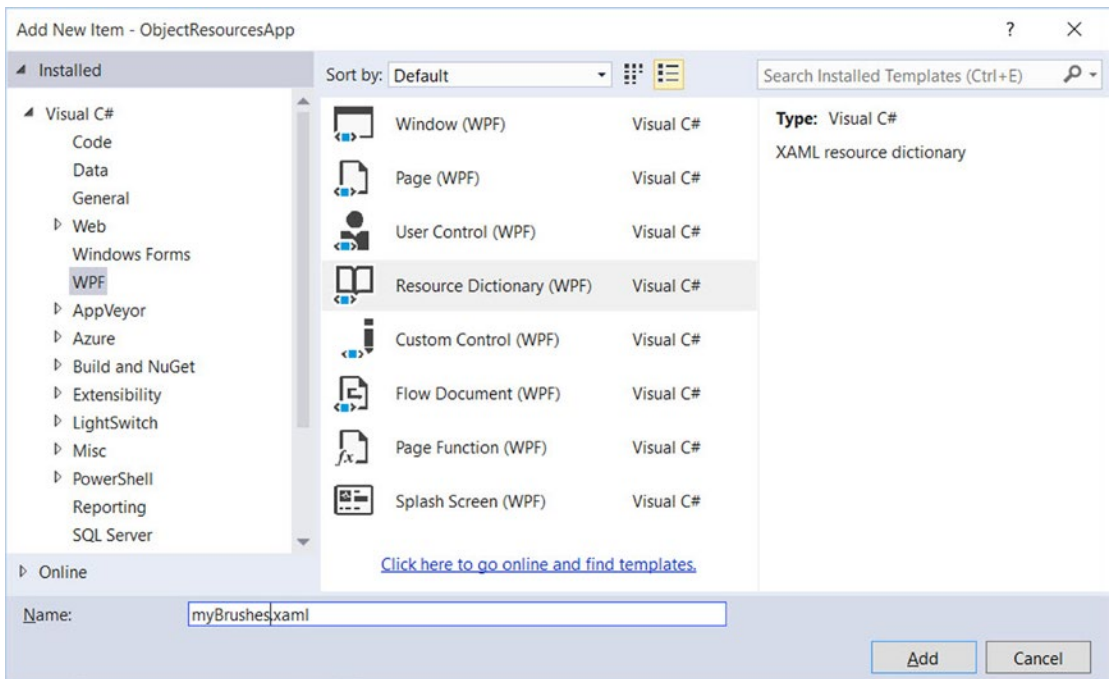

Figure 29-9. Inserting a new merged resource dictionary

In the new `MyBrushes.xaml` file, cut the current resources in the `Application.Resources` scope and move them into your dictionary, like so:

```
<ResourceDictionary xmlns=http://schemas.microsoft.com/winfx/2006/xaml/presentation
  xmlns:local="clr-namespace:ObjectResourcesApp"
  xmlns:x="http://schemas.microsoft.com/winfx/2006/xaml">

  <RadialGradientBrush x:Key="myBrush">
    <GradientStop Color="#FFC44EC4" Offset="0" />
    <GradientStop Color="#FF829CEB" Offset="1" />
    <GradientStop Color="#FF793879" Offset="0.669" />
  </RadialGradientBrush>

</ResourceDictionary>
```

Now, even though this resource dictionary is part of your project, you will get runtime errors. The reason is that all resource dictionaries must be merged (typically at the application level) into an existing resource dictionary. To do this, use the following format in the `App.xaml` file (note that multiple resource dictionaries can be merged by adding multiple `<ResourceDictionary>` elements within the `<ResourceDictionary.MergedDictionaries>` scope):

```
<Application x:Class="ObjectResourcesApp.App"
  xmlns="http://schemas.microsoft.com/winfx/2006/xaml/presentation"
  xmlns:x="http://schemas.microsoft.com/winfx/2006/xaml"
  xmlns:local="clr-namespace:ObjectResourcesApp"
  StartupUri="MainWindow.xaml">
```

```

<!-- Bring in the logical resources
      from the MyBrushes.xaml file. -->
<Application.Resources>
  <ResourceDictionary>
    <ResourceDictionary.MergedDictionaries>
      <ResourceDictionary Source = "MyBrushes.xaml"/>
    </ResourceDictionary.MergedDictionaries>
  </ResourceDictionary>
</Application.Resources>

</Application>

```

Defining a Resource-Only Assembly

Last but not least, it is possible to create .NET class libraries that contain nothing but dictionaries of object resources. This can be useful if you have defined a set of themes that need to be used on a machine-wide level. You could package up the object resource into a dedicated assembly, and then applications that need to make use of them could load them into memory.

The easiest way to build a resource-only assembly is to actually begin with a WPF User Control Library project. Add such a project (named `MyBrushesLibrary`) to your current solution via the Add ► New Project menu option of Visual Studio (see Figure 29-10).

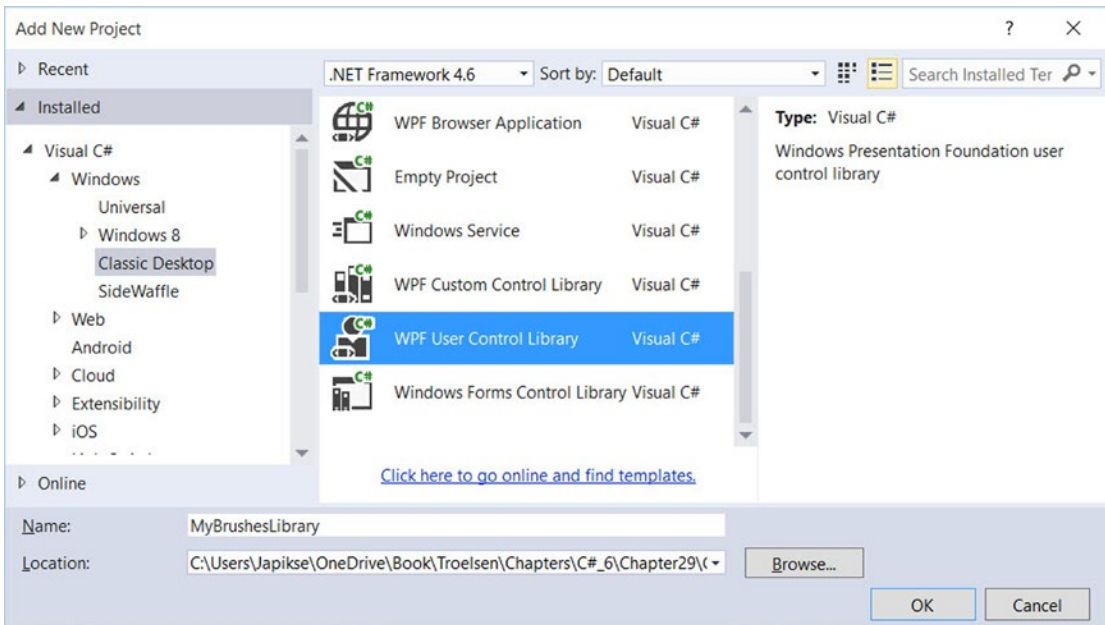

Figure 29-10. Adding a User Control Library as a starting point for a resource-only library

Now, completely delete the `UserControl1.xaml` file from the project (the only items you really want are the referenced WPF assemblies). Next, drag and drop the `MyBrushes.xaml` file into your `MyBrushesLibrary` project and delete it from the `ObjectResourcesApp` project. Finally, open `MyBrushes.xaml` in the `MyBrushesLibrary` project, and change the `x:local` namespace in the file to `clr-namespace:MyBrushesLibrary`. Your Solution Explorer should now look like Figure 29-11.

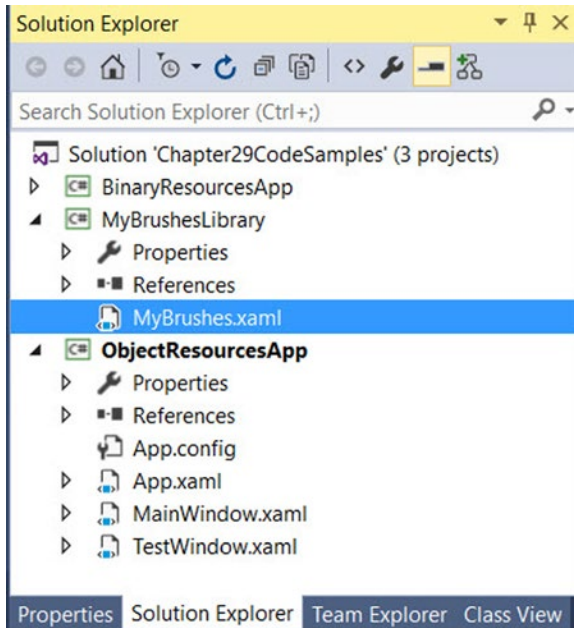

Figure 29-11. Moving the `MyBrushes.xaml` file into your new library project

Compile your User Control Library project. Next, reference this library from the `ObjectResourcesApp` project using the Add Reference dialog box. Now, merge these binary resources into the application-level resource dictionary of the `ObjectResourcesApp` project. Doing so, however, requires some rather funky syntax, shown here:

```
<Application.Resources>
  <ResourceDictionary>
    <ResourceDictionary.MergedDictionaries>
      <!-- The syntax is /NameOfAssembly;Component/NameOfXamlFileInAssembly.xaml -->
      <ResourceDictionary Source = "/MyBrushesLibrary;Component/MyBrushes.xaml"/>
    </ResourceDictionary.MergedDictionaries>
  </ResourceDictionary>
</Application.Resources>
```

First, be aware that this string is space-sensitive. If you have extra white space around your semicolon or forward slashes, you will generate runtime errors. The first part of the string is the friendly name of the external library (no file extension). After the semicolon, type in the word `Component` followed by the name of the compiled binary resource, which will be identical to the original XAML resource dictionary.

That wraps up our examination of WPF’s resource management system. You will make good use of these techniques for most of your applications. Next up, let’s investigate the integrated animation API of Windows Presentation Foundation.

■ **Source Code** The `ObjectResourcesApp` project can be found in the Chapter 29 subdirectory.

Understanding WPF’s Animation Services

In addition to the graphical rendering services you examined in Chapter 28, WPF supplies a programming interface to support animation services. The term *animation* may bring to mind visions of spinning company logos, a sequence of rotating image resources (to provide the illusion of movement), text bouncing across the screen, or specific types of programs such as video games or multimedia applications.

While WPF’s animation APIs could certainly be used for such purposes, animation can be used any time you want to give an application additional flair. For example, you could build an animation for a button on a screen that magnifies slightly when the mouse cursor hovers within its boundaries (and shrinks back once the mouse cursor moves beyond the boundaries). Or you could animate a window so that it closes using a particular visual appearance, such as slowly fading into transparency. In fact, WPF’s animation support can be used within any sort of application (a business application, multimedia programs, video games, etc.) whenever you want to provide a more engaging user experience.

As with many other aspects of WPF, the notion of building animations is nothing new. What is new is that, unlike other APIs you might have used in the past (including Windows Forms), developers are not required to author the necessary infrastructure by hand. Under WPF, there’s no need to create the background threads or timers used to advance the animation sequence, define custom types to represent the animation, erase and redraw images, or bother with tedious mathematical calculations. Like other aspects of WPF, we can build an animation entirely using XAML, entirely using C# code, or using a combination of the two.

■ **Note** Visual Studio has no support for authoring animations using GUI animation tools. If you author an animation with Visual Studio, you will do so by typing in the XAML directly. However, Blend for Visual Studio (the companion product that ships with Visual Studio 2015) does indeed have a built-in animation editor that can simplify your life a good deal.

The Role of the Animation Class Types

To understand WPF’s animation support, you must begin by examining the animation classes within the `System.Windows.Media.Animation` namespace of `PresentationCore.dll`. Here you will find over 100 different class types that are named using the `Animation` token.

All of these classes can be placed into one of three broad categories. First, any class that follows the name convention *Data Type Animation* (`ByteAnimation`, `ColorAnimation`, `DoubleAnimation`, `Int32Animation`, etc.) allows you to work with linear interpolation animations. This enables you to change a value smoothly over time from a start value to a final value.

Next, the classes that follow the naming convention *Data Type Animation Using Key Frames* (`StringAnimationUsingKeyFrames`, `DoubleAnimationUsingKeyFrames`, `PointAnimationUsingKeyFrames`, etc.) represent “key frame animations,” which allow you to cycle through a set of defined values over a period of time. For example, you could use key frames to change the caption of a button by cycling through a series of individual characters.

Finally, classes that follow the *DataTypeAnimationUsingPath* naming convention (*DoubleAnimationUsingPath*, *PointAnimationUsingPath*, among others) are path-based animations that allow you to animate objects to move along a path you define. By way of an example, if you were building a GPS application, you could use a path-based animation to move an item along the quickest travel route to the user's destination.

Now, obviously, these classes are *not* used to somehow provide an animation sequence directly to a variable of a particular data type (after all, how exactly could you animate the value "9" using an *Int32Animation?*).

For example, consider the *Label* type's *Height* and *Width* properties, both of which are dependency properties wrapping a *double*. If you wanted to define an animation that would increase the height of a label over a time span, you could connect a *DoubleAnimation* object to the *Height* property and allow WPF to take care of the details of performing the actual animation itself. By way of another example, if you wanted to transition the color of a brush type from green to yellow over a period of five seconds, you could do so using the *ColorAnimation* type.

To be very clear, these *Animation* classes can be connected to any *dependency property* of a given object that matches the underlying types. As explained in Chapter 27, dependency properties are a specialized form of property required by many WPF services including animation, data binding, and styles.

By convention, a dependency property is defined as a static, read-only field of the class, and is named by suffixing the word *Property* to the normal property name. For example, the dependency property for the *Height* property of a *Button* would be accessed in code using *Button.HeightProperty*.

The To, From, and By Properties

All *Animation* classes define the following handful of key properties that control the starting and ending values used to perform the animation:

- **To:** This property represents the animation's ending value.
- **From:** This property represents the animation's starting value.
- **By:** This property represents the total amount by which the animation changes its starting value.

Despite the fact that all *Animation* classes support the *To*, *From*, and *By* properties, they do not receive them via virtual members of a base class. The reason for this is that the underlying types wrapped by these properties vary greatly (integers, colors, *Thickness* objects, etc.), and representing all possibilities using a single base class would result in very complex coding constructs.

On a related note, you might also wonder why .NET generics were not used to define a single generic animation class with a single type parameter (e.g., *Animate<T>*). Again, given that there are so many underlying data types (colors, vectors, ints, strings, etc.) used to animated dependency properties, it would not be as clean a solution as you might expect (not to mention XAML has only limited support for generic types).

The Role of the Timeline Base Class

Although a single base class was not used to define virtual *To*, *From*, and *By* properties, the *Animation* classes do share a common base class: *System.Windows.Media.Animation.Timeline*. This type provides a number of additional properties that control the pacing of the animation, as described in Table 29-1.

Table 29-1. Key Members of the `Timeline` Base Class

| Properties | Meaning in Life |
|---|--|
| <code>AccelerationRatio</code> , <code>DecelerationRatio</code> , <code>SpeedRatio</code> | These properties can be used to control the overall pacing of the animation sequence. |
| <code>AutoReverse</code> | This property gets or sets a value that indicates whether the timeline plays in reverse after it completes a forward iteration (the default value is <code>false</code>). |
| <code>BeginTime</code> | This property gets or sets the time at which this timeline should begin. The default value is 0, which begins the animation immediately. |
| <code>Duration</code> | This property allows you to set a duration of time to play the timeline. |
| <code>FillBehavior</code> , <code>RepeatBehavior</code> | These properties are used to control what should happen once the timeline has completed (repeat the animation, do nothing, etc.). |

Authoring an Animation in C# Code

Specifically, you will build a `Window` that contains a `Button`, which has the odd behavior of spinning in a circle (based on the upper-left corner) whenever the mouse enters its surface area. Begin by creating a new WPF application named `SpinningButtonAnimationApp`, using Visual Studio. Update the initial markup to the following (note you are handling the button's `MouseEnter` event):

```
<Window x:Class="SpinningButtonAnimationApp.MainWindow"
  xmlns="http://schemas.microsoft.com/winfx/2006/xaml/presentation"
  xmlns:x="http://schemas.microsoft.com/winfx/2006/xaml"
  xmlns:d="http://schemas.microsoft.com/expression/blend/2008"
  xmlns:mc="http://schemas.openxmlformats.org/markup-compatibility/2006"
  xmlns:local="clr-namespace:SpinningButtonAnimationApp"
  mc:Ignorable="d"
  Title="Animations in C# code" Height="350"
  Width="525" WindowStartupLocation="CenterScreen">
  <Grid>
    <Button x:Name="btnSpinner" Height="50" Width="100" Content="I Spin!"
      MouseEnter="btnSpinner_MouseEnter"/>
  </Grid>
</Window>
```

Now, import the `System.Windows.Media.Animation` namespace and add the following code in the window's C# code file:

```
public partial class MainWindow : Window
{
  private bool _isSpinning = false;

  private void btnSpinner_MouseEnter(object sender, MouseEventArgs e)
  {
    if (!_isSpinning)
    {
      _isSpinning = true;
      // Make a double animation object, and register
```

```

// with the Completed event.
var dblAnim = new DoubleAnimation();
dblAnim.Completed += (o, s) => { _isSpinning = false; };

// Set the start value and end value.
dblAnim.From = 0;
dblAnim.To = 360;

// Now, create a RotateTransform object, and set
// it to the RenderTransform property of our
// button.
var rt = new RotateTransform();
btnSpinner.RenderTransform = rt;

// Now, animation the RotateTransform object.
rt.BeginAnimation(RotateTransform.AngleProperty, dblAnim);
}
}
}

```

The first major task of this method is to configure a `DoubleAnimation` object, which will start at the value 0 and end at the value 360. Notice that you are handling the `Completed` event on this object as well, to toggle a class-level `bool` variable that is used to ensure that if an animation is currently being performed, you don't "reset" it to start again.

Next, you create a `RotateTransform` object that is connected to the `RenderTransform` property of your `Button` control (`btnSpinner`). Last but not least, you inform the `RenderTransform` object to begin animating its `Angle` property using your `DoubleAnimation` object. When you are authoring animations in code, you typically do so by calling `BeginAnimation()`, and pass in the underlying *dependency property* you would like to animate (remember, by convention, this is a static field on the class), followed by a related animation object.

Let's add another animation to the program, which will cause the button to fade into invisibility when clicked. First, handle the `Click` event of the `btnSpinner` object, and then add the following code in the resulting event handler:

```

private void btnSpinner_Click(object sender, RoutedEventArgs e)
{
    var dblAnim = new DoubleAnimation
    {
        From = 1.0,
        To = 0.0
    };
    btnSpinner.BeginAnimation(Button.OpacityProperty, dblAnim);
}

```

Here, you are changing the `Opacity` property value to fade the button out of view. Currently, however, this is hard to do, as the button is spinning very fast! How, then, can you control the pace of an animation? Glad you asked.

Controlling the Pace of an Animation

By default, an animation will take approximately one second to transition between the values assigned to the `From` and `To` properties. Therefore, your button has one second to spin around a full 360-degree angle, while the button will fade away to invisibility (when clicked) over the course of one second.

If you want to define a custom amount of time for an animation's transition, you may do so via the animation object's `Duration` property, which can be set to an instance of a `Duration` object. Typically, the time span is established by passing a `TimeSpan` object to the `Duration`'s constructor. Consider the following update that will give the button a full four seconds to rotate:

```
private void btnSpinner_MouseEnter(object sender, MouseEventArgs e)
{
    if (!_isSpinning)
    {
        _isSpinning = true;

        // Make a double animation object, and register
        // with the Completed event.
        var dblAnim = new DoubleAnimation();
        dblAnim.Completed += (o, s) => { _isSpinning = false; };

        // Button has four seconds to finish the spin!
        dblAnim.Duration = new Duration(TimeSpan.FromSeconds(4));

        ...
    }
}
```

With this adjustment, you should have a fighting chance of clicking the button while it is spinning, at which point it will fade away.

■ **Note** The `BeginTime` property of an `Animation` class also takes a `TimeSpan` object. Recall that this property can be set to establish a wait time before starting an animation sequence.

Reversing and Looping an Animation

You can also tell `Animation` objects to play an animation in reverse at the completion of the animation sequence by setting the `AutoReverse` property to `true`. For example, if you want to have the button come back into view after it has faded away, you could author the following:

```
private void btnSpinner_Click(object sender, RoutedEventArgs e)
{
    DoubleAnimation dblAnim = new DoubleAnimation
    {
        From = 1.0,
        To = 0.0
    };
}
```

```

// Reverse when done.
dblAnim.AutoReverse = true;
btnSpinner.BeginAnimation(Button.OpacityProperty, dblAnim);
}

```

If you'd like to have an animation repeat some number of times (or to never stop once activated), you can do so using the `RepeatBehavior` property, which is common to all `Animation` classes. If you pass in a simple numerical value to the constructor, you can specify a hard-coded number of times to repeat. On the other hand, if you pass in a `TimeSpan` object to the constructor, you can establish an amount of time the animation should repeat. Finally, if you want an animation to loop ad infinitum, you can simply specify `RepeatBehavior.Forever`. Consider the following ways you could change the repeat behaviors of either of the `DoubleAnimation` objects used in this example:

```

// Loop forever.
dblAnim.RepeatBehavior = RepeatBehavior.Forever;

// Loop three times.
dblAnim.RepeatBehavior = new RepeatBehavior(3);

// Loop for 30 seconds.
dblAnim.RepeatBehavior = new RepeatBehavior(TimeSpan.FromSeconds(30));

```

That wraps up your investigation about how to animate aspects of an object using C# code and the WPF animation API. Next, you will learn how to do the same using XAML.

■ **Source Code** The `SpinningButtonAnimationApp` project can be found in the [Chapter 29](#) subdirectory.

Authoring Animations in XAML

Authoring animations in markup is similar to authoring them in code, at least for simple, straightforward animation sequences. When you need to capture more complex animations, which may involve changing the values of numerous properties at once, the amount of markup can grow considerably. Even if you use a tool to generate XAML-based animations, it is important to know the basics of how an animation is represented in XAML because this will make it easier for you to modify and tweak tool-generated content.

■ **Note** You will find a number of XAML files in the `XamlAnimations` folder of the downloadable source code. As you go through the next several pages, copy these markup files into your custom XAML editor or into the `Kaxaml` editor to see the results.

For the most part, creating an animation is similar to what you have already seen. You still configure an `Animation` object and associate it to an object's property. One big difference, however, is that WPF is not function call-friendly. As a result, instead of calling `BeginAnimation()`, you use a *storyboard* as a layer of indirection.

Let's walk through a complete example of an animation defined in terms of XAML, followed by a detailed breakdown. The following XAML definition will display a window that contains a single label. As soon as the `Label` object loads into memory, it begins an animation sequence in which the font size increases from 12 points to 100 over a period of four seconds. The animation will repeat for as long as the `Window` object is loaded in memory. You can find this markup in the `GrowLabelFont.xaml` file, so copy it into your `MyXamlPad.exe` application (or `Kaxaml`) and observe the behavior:

```
<Window
  xmlns="http://schemas.microsoft.com/winfx/2006/xaml/presentation"
  xmlns:x="http://schemas.microsoft.com/winfx/2006/xaml"
  Height="200" Width="600" WindowStartupLocation="CenterScreen" Title="Growing Label Font!">
  <StackPanel>
    <Label Content = "Interesting...">
      <Label.Triggers>
        <EventTrigger RoutedEvent = "Label.Loaded">
          <EventTrigger.Actions>
            <BeginStoryboard>
              <Storyboard TargetProperty = "FontSize">
                <DoubleAnimation From = "12" To = "100" Duration = "0:0:4"
                  RepeatBehavior = "Forever"/>
              </Storyboard>
            </BeginStoryboard>
          </EventTrigger.Actions>
        </EventTrigger>
      </Label.Triggers>
    </Label>
  </StackPanel>
</Window>
```

Now, let's break this example down, bit by bit.

The Role of Storyboards

Working from the innermost element outward, you first encounter the `<DoubleAnimation>` element, which makes use of the same properties you set in procedural code (`From`, `To`, `Duration`, and `RepeatBehavior`).

```
<DoubleAnimation From = "12" To = "100" Duration = "0:0:4"
  RepeatBehavior = "Forever"/>
```

As mentioned, `Animation` elements are placed within a `<Storyboard>` element, which is used to map the animation object to a given property on the parent type via the `TargetProperty` property, which in this case is `FontSize`. A `<Storyboard>` is always wrapped in a parent element named `<BeginStoryboard>`.

```
<BeginStoryboard>
  <Storyboard TargetProperty = "FontSize">
    <DoubleAnimation From = "12" To = "100" Duration = "0:0:4"
      RepeatBehavior = "Forever"/>
  </Storyboard>
</BeginStoryboard>
```

The Role of Event Triggers

After the `<BeginStoryboard>` element has been defined, you need to specify some sort of action that will cause the animation to begin executing. WPF has a few different ways to respond to runtime conditions in markup, one of which is termed a *trigger*. From a high level, you can consider a trigger a way of responding to an event condition in XAML, without the need for procedural code.

Typically, when you respond to an event in C#, you author custom code that will execute when the event occurs. A trigger, however, is just a way to be notified that some event condition has happened (“I’m loaded into memory”, “The mouse is over me!”, “I have focus!”).

Once you’ve been notified that an event condition has occurred, you can start the storyboard. In this example, you are responding to the `Label` being loaded into memory. Because it is the `Label`’s `Loaded` event you are interested in, the `<EventTrigger>` is placed in the `Label`’s trigger collection.

```
<Label Content = "Interesting...">
  <Label.Triggers>
    <EventTrigger RoutedEvent = "Label.Loaded">
      <EventTrigger.Actions>
        <BeginStoryboard>
          <Storyboard TargetProperty = "FontSize">
            <DoubleAnimation From = "12" To = "100" Duration = "0:0:4"
              RepeatBehavior = "Forever"/>
          </Storyboard>
        </BeginStoryboard>
      </EventTrigger.Actions>
    </EventTrigger>
  </Label.Triggers>
</Label>
```

Let’s see another example of defining an animation in XAML, this time using a *key frame* animation.

Animation Using Discrete Key Frames

Unlike the linear interpolation animation objects, which can only move between a starting point and an ending point, the *key frame* counterparts allow you to create a collection of specific values for an animation that should take place at specific times.

To illustrate the use of a discrete key frame type, assume you want to build a `Button` control that animates its content so that over the course of three seconds the value “OK!” appears, one character at a time. You’ll find the following markup in the `AnimateString.xaml` file. Copy this markup into your `MyXamlPad.exe` program (or `Kaxaml`) and view the results:

```
<Window xmlns="http://schemas.microsoft.com/winfx/2006/xaml/presentation"
  xmlns:x="http://schemas.microsoft.com/winfx/2006/xaml"
  Height="100" Width="300"
  WindowStartupLocation="CenterScreen" Title="Animate String Data!">
  <StackPanel>
    <Button Name="myButton" Height="40"
      FontSize="16pt" FontFamily="Verdana" Width = "100">
      <Button.Triggers>
```

```

<EventTrigger RoutedEvent="Button.Loaded">
  <BeginStoryboard>
    <Storyboard>
      <StringAnimationUsingKeyFrames RepeatBehavior = "Forever"
        Storyboard.TargetProperty="Content"
        Duration="0:0:3">
        <DiscreteStringKeyFrame Value="" KeyTime="0:0:0" />
        <DiscreteStringKeyFrame Value="0" KeyTime="0:0:1" />
        <DiscreteStringKeyFrame Value="OK" KeyTime="0:0:1.5" />
        <DiscreteStringKeyFrame Value="OK!" KeyTime="0:0:2" />
      </StringAnimationUsingKeyFrames>
    </Storyboard>
  </BeginStoryboard>
</EventTrigger>
</Button.Triggers>
</Button>
</StackPanel>
</Window>

```

First, notice that you have defined an event trigger for your button to ensure that your storyboard executes when the button has loaded into memory. The `StringAnimationUsingKeyFrames` class is in charge of changing the content of the button, via the `Storyboard.TargetProperty` value.

Within the scope of the `<StringAnimationUsingKeyFrames>` element, you define four `DiscreteStringKeyFrame` elements, which change the button's `Content` property over the course of two seconds (note that the duration established by `StringAnimationUsingKeyFrames` is a total of three seconds, so you will see a slight pause between the final "!" and looping "O").

Now that you have a better feel for how to build animations in C# code and XAML, let's look at the role of WPF styles, which make heavy use of graphics, object resources, and animations.

■ **Source Code** These loose XAML files can be found in the `XamlAnimations` subdirectory of Chapter 29.

Understanding the Role of WPF Styles

When you are building the UI of a WPF application, it is not uncommon for a family of controls to require a shared look and feel. For example, you might want all button types have the same height, width, background color, and font size for their string content. Although you could handle this by setting each button's individual properties to identical values, such an approach makes it difficult to implement changes down the road because you would need to reset the same set of properties on multiple objects for every change.

Thankfully, WPF offers a simple way to constrain the look and feel of related controls using *styles*. Simply put, a WPF style is an object that maintains a collection of property/value pairs. Programmatically speaking, an individual style is represented using the `System.Windows.Style` class. This class has a property named `Setters`, which exposes a strongly typed collection of `Setter` objects. It is the `Setter` object that allows you to define the property/value pairs.

In addition to the `Setters` collection, the `Style` class also defines a few other important members that allow you to incorporate triggers, restrict where a style can be applied, and even create a new style based on an existing style (think of it as “style inheritance”). In particular, be aware of the following members of the `Style` class:

- `Triggers`: Exposes a collection of trigger objects, which allow you to capture various event conditions within a style.
- `BasedOn`: Allows you to build a new style based on an existing style.
- `TargetType`: Allows you to constrain where a style can be applied.

Defining and Applying a Style

In almost every case, a `Style` object will be packaged as an object resource. Like any object resource, you can package it at the window or application level, as well as within a dedicated resource dictionary (this is great because it makes the `Style` object easily accessible throughout your application). Now recall that the goal is to define a `Style` object that fills (at minimum) the `Setters` collection with a set of property/value pairs.

Create a new WPF application named `WpfStyles` using Visual Studio. Let’s build a style that captures the basic font characteristics of a control in your application. Open your `App.xaml` file and define the following named style:

```
<Application x:Class="WpfStyles.App"
  xmlns="http://schemas.microsoft.com/winfx/2006/xaml/presentation"
  xmlns:x="http://schemas.microsoft.com/winfx/2006/xaml"
  xmlns:d="http://schemas.microsoft.com/expression/blend/2008"
  xmlns:mc="http://schemas.openxmlformats.org/markup-compatibility/2006"
  xmlns:local="clr-namespace:WpfStyles"
  mc:Ignorable="d"
  StartupUri="MainWindow.xaml">
  <Application.Resources>
    <Style x:Key="BasicControlStyle">
      <Setter Property="Control.FontSize" Value="14"/>
      <Setter Property="Control.Height" Value="40"/>
      <Setter Property="Control.Cursor" Value="Hand"/>
    </Style>
  </Application.Resources>
</Application>
```

Notice that your `BasicControlStyle` adds three `Setter` objects to the internal collection. Now, let’s apply this style to a few controls in your main window. Because this style is an object resource, the controls that want to use it still need to use the `{StaticResource}` or `{DynamicResource}` markup extension to locate the style. (As you know from the earlier discussion on static vs. dynamic resources, static ones are a tad bit more efficient, but are limited in how they get updated, so choose the one that best fits your needs.) When they find the style, they will set the resource item to the identically named `Style` property. Consider the following `<Window>` definition:

```
<Window x:Class="WpfStyles.MainWindow"
  xmlns="http://schemas.microsoft.com/winfx/2006/xaml/presentation"
  xmlns:x="http://schemas.microsoft.com/winfx/2006/xaml"
  xmlns:d="http://schemas.microsoft.com/expression/blend/2008"
```

```

xmlns:mc="http://schemas.openxmlformats.org/markup-compatibility/2006"
xmlns:local="clr-namespace:WpfStyles"
mc:Ignorable="d"
Title="A Window with Style!" Height="229"
Width="525" WindowStartupLocation="CenterScreen">

<StackPanel>
  <Label x:Name="lblInfo" Content="This style is boring..."
    Style="{StaticResource BasicControlStyle}" Width="150"/>
  <Button x:Name="btnTestButton" Content="Yes, but we are reusing settings!"
    Style="{StaticResource BasicControlStyle}" Width="250"/>
</StackPanel>

</Window>

```

If you run this application, you'll find that both controls support the same cursor, height, and font size.

Overriding Style Settings

Here you have a `Button` and `Label` that have both opted in to the constraints enforced by your style. Of course, if a control wants to apply a style and then change some of the defined settings, that's fine. For example, the `Button` will now use the `Help` cursor (rather than the `Hand` cursor defined in the style):

```

<Button x:Name="btnTestButton" Content="Yes, but we are reusing settings!"
  Cursor="Help" Style="{StaticResource BasicControlStyle}" Width="250" />

```

Styles are processed before the individual property settings of the control using the style; therefore, controls can “override” settings on a case-by-case basis.

Limiting Application of a Style with `TargetType`

Currently, your style is defined in such a way that any control can adopt it (and has to do so explicitly by setting the control's `Style` property), given that each property is qualified by the `Control` class. For a program that defines dozens of settings, this would entail a good amount of repeated code. One way to clean this style up a bit is to use the `TargetType` attribute. When you add this attribute to a `Style`'s opening element, you can mark exactly once where it can be applied (in this example, in `App.XAML`).

```

<Style x:Key="BasicControlStyle" TargetType="Control">
  <Setter Property="FontSize" Value="14"/>
  <Setter Property="Height" Value="40"/>
  <Setter Property="Cursor" Value="Hand"/>
</Style>

```

■ **Note** When you build a style that uses a base class type, you needn't be concerned if you assign a value to a dependency property not supported by derived types. If the derived type does not support a given dependency property, it is ignored.

This is somewhat helpful, but you still have a style that can apply to any control. The `TargetType` attribute is more useful when you want to define a style that can be applied to only a particular type of control. Add the following new style to the application's resource dictionary:

```
<Style x:Key = "BigGreenButton" TargetType="Button">
  <Setter Property = "FontSize" Value = "20"/>
  <Setter Property = "Height" Value = "100"/>
  <Setter Property = "Width" Value = "100"/>
  <Setter Property = "Background" Value = "DarkGreen"/>
  <Setter Property = "Foreground" Value = "Yellow"/>
</Style>
```

This style will work only on `Button` controls (or a subclass of `Button`). If you apply it to an incompatible element, you will get markup and compiler errors. If the `Button` uses this new style,

```
<Button x:Name="btnTestButton" Content="OK!"
        Cursor="Help" Style="{StaticResource BigGreenButton}" Width="250" />
```

you'll see output like that shown in Figure 29-12.



Figure 29-12. Controls with different styles

Another effect of `TargetType` is that the style will get applied to all elements of that type within the scope of the style definition as long as the `x:Key` property *doesn't* exist. More on this shortly.

Automatically Applying a Style with `TargetType`

Assume you need to ensure that all `TextBox` controls have the same look and feel. Now assume you have defined a style as an application-level resource, so all windows in the program have access to it. While this is a step in the right direction, if you have numerous windows with numerous `TextBox` controls, you'll need to set the `Style` property numerous times!

WPF styles can be implicitly applied to all controls within a given XAML scope. To create such a style, you use the `TargetType` property but you don't assign the `Style` resource an `x:Key` value. This "unnamed style" now applies to all controls of the correct type. Here is another application-level style that will apply automatically to all `TextBox` controls in the current application:

```
<!-- The default style for all text boxes. -->
<Style TargetType="TextBox">
  <Setter Property = "FontSize" Value = "14"/>
  <Setter Property = "Width" Value = "100"/>
  <Setter Property = "Height" Value = "30"/>
```

```

<Setter Property = "BorderThickness" Value = "5"/>
<Setter Property = "BorderBrush" Value = "Red"/>
<Setter Property = "FontStyle" Value = "Italic"/>
</Style>

```

You can now define any number of `TextBox` controls and they will automatically get the defined look. If a given `TextBox` does not want this default look and feel, it can opt out by setting the `Style` property to `{x:Null}`. For example, `txtTest` will get the default unnamed style, while `txtTest2` is doing things its own way:

```

<TextBox x:Name="txtTest"/>
<TextBox x:Name="txtTest2" Style="{x:Null}" BorderBrush="Black"
        BorderThickness="5" Height="60" Width="100" Text="Ha!"/>

```

Subclassing Existing Styles

You can also build new styles using an existing style, via the `BasedOn` property. The style you are extending must have been given a proper `x:Key` in the dictionary, as the derived style will reference it by name using the `{StaticResource}` or `{DynamicResource}` markup extension. Here is a new style based on `BigGreenButton`, which rotates the button element by 20 degrees:

```

<!-- This style is based on BigGreenButton. -->
<Style x:Key = "TiltButton" TargetType="Button" BasedOn = "{StaticResource BigGreenButton}">
  <Setter Property = "Foreground" Value = "White"/>
  <Setter Property = "RenderTransform">
    <Setter.Value>
      <RotateTransform Angle = "20"/>
    </Setter.Value>
  </Setter>
</Style>

```

This time the output appears as in Figure 29-13.



Figure 29-13. Using a derived style

Defining Styles with Triggers

WPF styles can also contain triggers by packaging up `Trigger` objects within the `Triggers` collection of the `Style` object. Using triggers in a style allows you to define certain `<Setter>` elements in such a way that they will be applied only if a given trigger condition is true. For example, perhaps you want to increase the size of

a font when the mouse is over a button. Or maybe you want to make sure that the text box with the current focus is highlighted with a given color. Triggers are very useful for these sorts of situations, in that they allow you to take specific actions when a property changes, without the need to author explicit C# code in a code-behind file.

Here is an update to the `TextBox` style that ensures that when a `TextBox` has the input focus, it will receive a yellow background:

```
<!-- The default style for all text boxes. -->
<Style TargetType="TextBox">
  <Setter Property = "FontSize" Value = "14"/>
  <Setter Property = "Width" Value = "100"/>
  <Setter Property = "Height" Value = "30"/>
  <Setter Property = "BorderThickness" Value = "5"/>
  <Setter Property = "BorderBrush" Value = "Red"/>
  <Setter Property = "FontStyle" Value = "Italic"/>
  <!-- The following setter will be applied only when the text box is
in focus. -->
  <Style.Triggers>
    <Trigger Property = "IsFocused" Value = "True">
      <Setter Property = "Background" Value = "Yellow"/>
    </Trigger>
  </Style.Triggers>
</Style>
```

If you test this style, you'll find that as you tab between various `TextBox` objects, the currently selected `TextBox` has a bright yellow background (provided it has not opted out by assigning `{x:Null}` to the `Style` property).

Property triggers are also very smart, in that when the trigger's condition is *not true*, the property automatically receives the default assigned value. Therefore, as soon as a `TextBox` loses focus, it also automatically becomes the default color without any work on your part. In contrast, event triggers (examined when you looked at WPF animations) do not automatically revert to a previous condition.

Defining Styles with Multiple Triggers

Triggers can also be designed in such a way that the defined `<Setter>` elements will be applied when *multiple conditions* are true. Let's say you want to set the background of a `TextBox` to `Yellow` only if it has the active focus and the mouse is hovering within its boundaries. To do so, you can make use of the `<MultiTrigger>` element to define each condition, like so:

```
<!-- The default style for all text boxes. -->
<Style TargetType="TextBox">
  <Setter Property = "FontSize" Value = "14"/>
  <Setter Property = "Width" Value = "100"/>
  <Setter Property = "Height" Value = "30"/>
  <Setter Property = "BorderThickness" Value = "5"/>
  <Setter Property = "BorderBrush" Value = "Red"/>
  <Setter Property = "FontStyle" Value = "Italic"/>
  <!-- The following setter will be applied only when the text box is
in focus AND the mouse is over the text box. -->
```

```

<Style.Triggers>
  <MultiTrigger>
    <MultiTrigger.Conditions>
      <Condition Property = "IsFocused" Value = "True"/>
      <Condition Property = "IsMouseOver" Value = "True"/>
    </MultiTrigger.Conditions>
    <Setter Property = "Background" Value = "Yellow"/>
  </MultiTrigger>
</Style.Triggers>
</Style>

```

Animated Styles

Styles can also incorporate triggers that kick off an animation sequence. Here is one final style that, when applied to Button controls, will cause the controls to grow and shrink in size when the mouse is inside the button's surface area:

```

<!-- The growing button style! -->
<Style x:Key = "GrowingButtonStyle" TargetType="Button">
  <Setter Property = "Height" Value = "40"/>
  <Setter Property = "Width" Value = "100"/>
  <Style.Triggers>
    <Trigger Property = "IsMouseOver" Value = "True">
      <Trigger.EnterActions>
        <BeginStoryboard>
          <Storyboard TargetProperty = "Height">
            <DoubleAnimation From = "40" To = "200"
              Duration = "0:0:2" AutoReverse="True"/>
          </Storyboard>
        </BeginStoryboard>
      </Trigger.EnterActions>
    </Trigger>
  </Style.Triggers>
</Style>

```

Here, the triggers collection is on the lookout for the `IsMouseOver` property to return `true`. When this occurs, you define a `<Trigger.EnterActions>` element to execute a simple storyboard that forces the button to grow to a `Height` value of 200 (and then return to a `Height` of 40) over two seconds. If you want to perform other property changes, you could also define a `<Trigger.ExitActions>` scope to define any custom actions to take when `IsMouseOver` changes to false.

Assigning Styles Programmatically

Recall that a style can be applied at runtime as well. This can be helpful if you want to let end users choose how their UI looks and feels, or if you need to enforce a look and feel based on security settings (e.g., the `DisableAllButton` style) or what have you.

During this project, you have defined a number of styles, many of which can apply to Button controls. So, let's retool the UI of your main window to allow the user to pick from some of these styles by selecting

names in a `ListBox`. Based on the user's selection, you will apply the appropriate style. Here is the new (and final) markup for the `<Window>` element:

```
<Window x:Class="WpfStyles.MainWindow"
  xmlns:d="http://schemas.microsoft.com/expression/blend/2008"
  xmlns:mc="http://schemas.openxmlformats.org/markup-compatibility/2006"
  xmlns:local="clr-namespace:WpfStyles"
  mc:Ignorable="d"
  Height="350" Title="A Window with Style!"
  Width="525" WindowStartupLocation="CenterScreen">

  <DockPanel >
    <StackPanel Orientation="Horizontal" DockPanel.Dock="Top">
      <Label Content="Please Pick a Style for this Button" Height="50"/>
      <ListBox x:Name ="lstStyles" Height ="80" Width ="150" Background="LightBlue"
        SelectionChanged ="comboStyles_Changed" />
    </StackPanel>
    <Button x:Name="btnStyle" Height="40" Width="100" Content="OK!"/>
  </DockPanel>

</Window>
```

The `ListBox` control (named `lstStyles`) will be filled dynamically within the window's constructor, like so:

```
public MainWindow()
{
  InitializeComponent();

  // Fill the list box with all the Button
  // styles.
  lstStyles.Items.Add("GrowingButtonStyle");
  lstStyles.Items.Add("TiltButton");
  lstStyles.Items.Add("BigGreenButton");
  lstStyles.Items.Add("BasicControlStyle");}
}
```

The final task is to handle the `SelectionChanged` event in the related code file. Notice in the following code how you are able to extract the current resource by name, using the inherited `TryFindResource()` method:

```
private void comboStyles_Changed(object sender, SelectionChangedEventArgs e)
{
  // Get the selected style name from the list box.
  var currStyle = (Style)TryFindResource(lstStyles.SelectedValue);
  if (currStyle == null) return;
  // Set the style of the button type.
  this.btnStyle.Style = currStyle;
}
```

When you run this application, you can pick from one of these four button styles on the fly. Figure 29-14 shows your completed application.

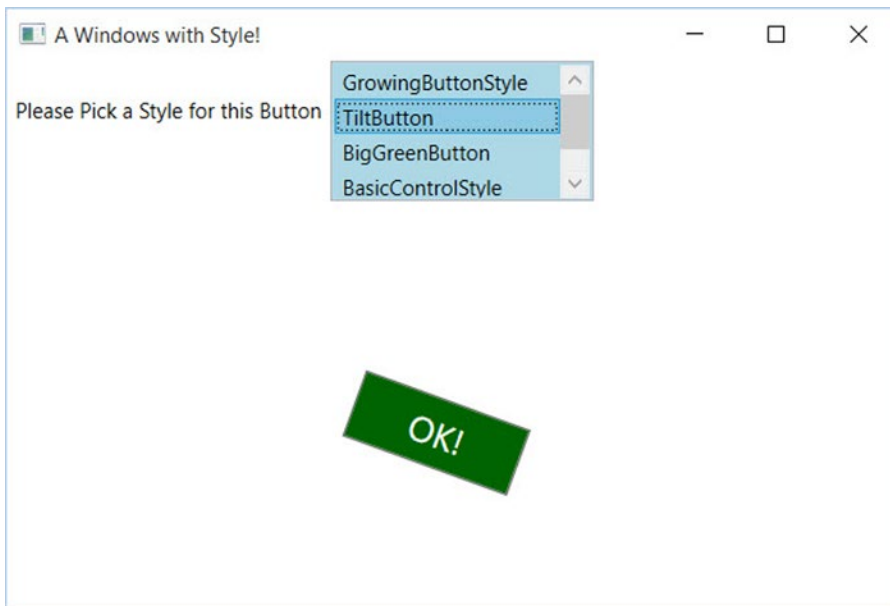

Figure 29-14. Controls with different styles

■ **Source Code** The `WpfStyles` project can be found in the [Chapter 29](#) subdirectory.

Logical Trees, Visual Trees, and Default Templates

Now that you understand styles and resources, there are a few more preparatory topics to investigate before you begin learning how to build custom controls. Specifically, you need to learn the distinction between a *logical tree*, a *visual tree*, and a *default template*. When you are typing XAML into Visual Studio, or a tool such as `kaxaml.exe`, your markup is the *logical view* of the XAML document. As well, if you author C# code that adds new items to a `StackPanel` control, you are inserting new items into the logical tree. Essentially, a logical view represents how your content will be positioned within the various layout managers for a main Window (or another root element, such as `Page` or `NavigationWindow`).

However, behind every logical tree is a much more verbose representation termed a *visual tree*, which is used internally by WPF to correctly render out elements onto the screen. Within any visual tree, there will be full details of the templates and styles used to render out each object, including any necessary drawings, shapes, visuals, and animations.

It is useful to understand the distinction between logical and visual trees because when you are building a custom control template, you are essentially replacing all or part of the default visual tree of a control and inserting your own. Therefore, if you want a `Button` control to be rendered as a star shape, you could define a new star template and plug it into the `Button`'s visual tree. Logically, the `Button` is still of type `Button`, and it supports all of the properties, methods, and events as expected. But visually, it has taken on a whole new appearance. This fact alone makes WPF an extremely useful API, given that other toolkits would require you to build a brand new class to make a star-shaped button. With WPF, you simply need to define new markup.

■ **Note** WPF controls are often described as *lookless*. This refers to the fact that the look and feel of a WPF control is completely independent (and customizable) from its behavior.

Programmatically Inspecting a Logical Tree

While analyzing a window's logical tree at runtime is not a tremendously common WPF programming activity, it is worth mentioning that the `System.Windows` namespace defines a class named `LogicalTreeHelper`, which allows you to inspect the structure of a logical tree at runtime. To illustrate the connection between logical trees, visual trees, and control templates, create a new WPF application named `TreesAndTemplatesApp`.

Update the markup for your window so that it contains two `Button` controls and a large read-only `TextBox` with scrollbars enabled. Make sure you use the IDE to handle the `Click` event of each button. The following XAML will do nicely:

```
<Window x:Class="TreesAndTemplatesApp.MainWindow"
  xmlns:d="http://schemas.microsoft.com/expression/blend/2008"
  xmlns:mc="http://schemas.openxmlformats.org/markup-compatibility/2006"
  xmlns:local="clr-namespace:TreesAndTemplatesApp"
  mc:Ignorable="d"
  Title="Fun with Trees and Templates" Height="518"
  Width="836" WindowStartupLocation="CenterScreen">

  <DockPanel LastChildFill="True">
    <Border Height="50" DockPanel.Dock="Top" BorderBrush="Blue">
      <StackPanel Orientation="Horizontal">
        <Button x:Name="btnShowLogicalTree" Content="Logical Tree of Window"
          Margin="4" BorderBrush="Blue" Height="40" Click="btnShowLogicalTree_Click"/>
        <Button x:Name="btnShowVisualTree" Content="Visual Tree of Window"
          BorderBrush="Blue" Height="40" Click="btnShowVisualTree_Click"/>
      </StackPanel>
    </Border>
    <TextBox x:Name="txtDisplayArea" Margin="10" Background="AliceBlue" IsReadOnly="True"
      BorderBrush="Red" VerticalScrollBarVisibility="Auto"
      HorizontalScrollBarVisibility="Auto" />
  </DockPanel>
</Window>
```

Within your C# code file, define a string member variable named `_dataToShow`. Now, within the `Click` handler for the `btnShowLogicalTree` object, call a helper function that calls itself recursively in order to populate the string variable with the logical tree of the `Window`. To do so, you will call the static `GetChildren()` method of `LogicalTreeHelper`. Here is the code:

```
private string _dataToShow = string.Empty;

private void btnShowLogicalTree_Click(object sender, RoutedEventArgs e)
{
    _dataToShow = "";
    BuildLogicalTree(0, this);
    txtDisplayArea.Text = _dataToShow;
}
```

```

void BuildLogicalTree(int depth, object obj)
{
    // Add the type name to the dataToShow member variable.
    _dataToShow += new string(' ', depth) + obj.GetType().Name + "\n";

    // If an item is not a DependencyObject, skip it.
    if (!(obj is DependencyObject))
        return;

    // Make a recursive call for each logical child.
    foreach (var child in LogicalTreeHelper.GetChildren(
        (DependencyObject)obj))
    {
        BuildLogicalTree(depth + 5, child);
    }
}

```

If you run your application and click this first button, you will see a tree print out in the text area, which is just about an exact replica of the original XAML (see Figure 29-15).

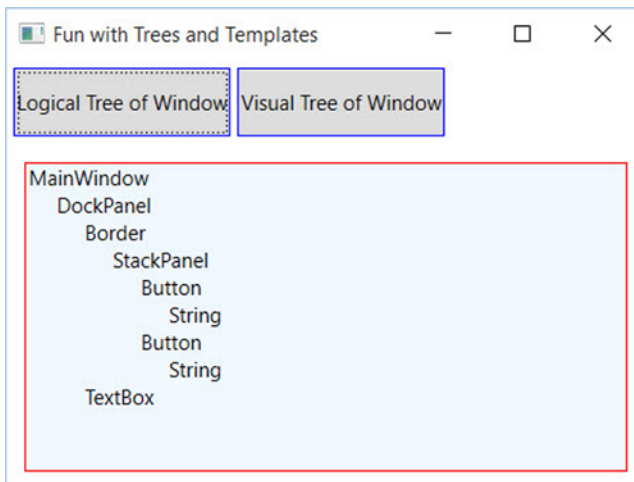

Figure 29-15. Viewing a logical tree at runtime

Programmatically Inspecting a Visual Tree

A Window's visual tree can also be inspected at runtime using the `VisualTreeHelper` class of `System.Windows.Media`. Here is a `Click` implementation of the second `Button` control (`btnShowVisualTree`), which performs similar recursive logic to build a textual representation of the visual tree:

```

private void btnShowVisualTree_Click(object sender, RoutedEventArgs e)
{
    _dataToShow = "";
    BuildVisualTree(0, this);
    txtDisplayArea.Text = _dataToShow;
}

```

```

void BuildVisualTree(int depth, DependencyObject obj)
{
    // Add the type name to the dataToShow member variable.
    _dataToShow += new string(' ', depth) + obj.GetType().Name + "\n";
    // Make a recursive call for each visual child.
    for (int i = 0; i < VisualTreeHelper.GetChildrenCount(obj); i++)
    {
        BuildVisualTree(depth + 1, VisualTreeHelper.GetChild(obj, i));
    }
}

```

As you can see in Figure 29-16, the visual tree exposes a number of lower-level rendering agents such as `ContentPresenter`, `AdornerDecorator`, `TextBoxLineDrawingVisual`, and so forth.

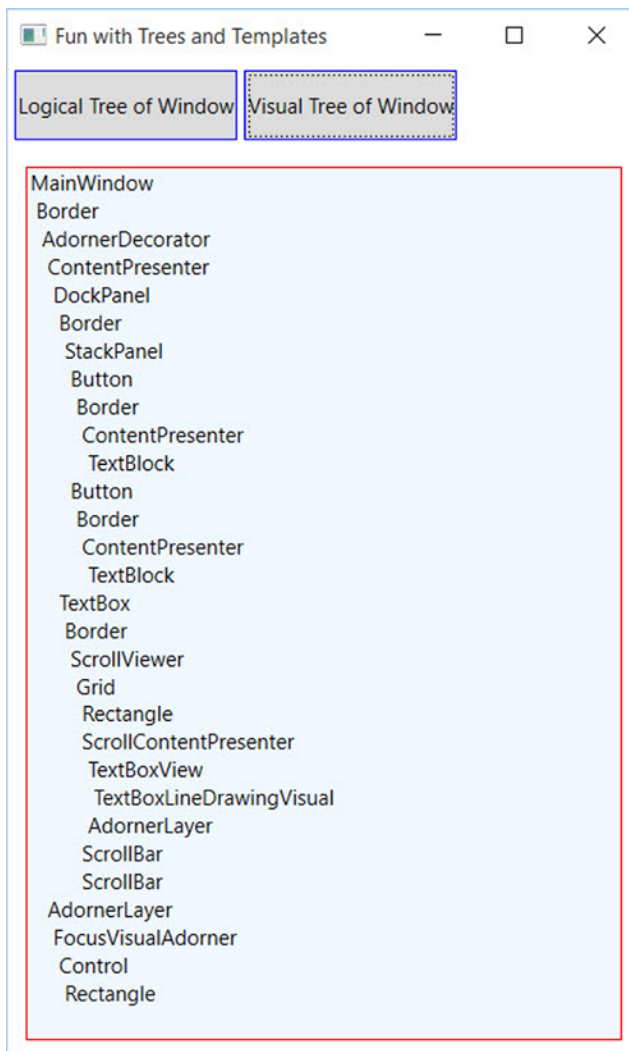

Figure 29-16. Viewing a visual tree at runtime

Programmatically Inspecting a Control's Default Template

Recall that a visual tree is used by WPF to understand how to render a window and all contained elements. Every WPF control stores its own set of rendering commands within its default template. Programmatically speaking, any template can be represented as an instance of the `ControlTemplate` class. As well, you can obtain a control's default template by using the aptly named `Template` property, like so:

```
// Get the default template of the Button.
Button myBtn = new Button();
ControlTemplate template = myBtn.Template;
```

Likewise, you could create a new `ControlTemplate` object in code and plug it into a control's `Template` property as follows:

```
// Plug in a new template for the button to use.
Button myBtn = new Button();
ControlTemplate customTemplate = new ControlTemplate();

// Assume this method adds all the code for a star template.
MakeStarTemplate(customTemplate);
myBtn.Template = customTemplate;
```

While you could build a new template in code, it is far more common to do so in XAML. However, before you start building your own templates, let's finish the current example and add the ability to view the default template of a WPF control at runtime. This can be a really useful way to take a look at the overall composition of a template. First, update the markup of your window with a new `StackPanel` of controls docked to the left side of the master `DockPanel`, defined as so (placed just before the `<TextBox>` element):

```
<Border DockPanel.Dock="Left" Margin="10" BorderBrush="DarkGreen"
        BorderThickness="4" Width="358">
  <StackPanel>
    <Label Content="Enter Full Name of WPF Control" Width="340" FontWeight="DemiBold" />
    <TextBox x:Name="txtFullName" Width="340" BorderBrush="Green"
            Background="BlanchedAlmond" Height="22"
            Text="System.Windows.Controls.Button" />
    <Button x:Name="btnTemplate" Content="See Template" BorderBrush="Green"
            Height="40" Width="100" Margin="5"
            Click="btnTemplate_Click" HorizontalAlignment="Left" />
    <Border BorderBrush="DarkGreen" BorderThickness="2" Height="260"
            Width="301" Margin="10" Background="LightGreen" >
      <StackPanel x:Name="stackTemplatePanel" />
    </Border>
  </StackPanel>
</Border>
```

Do take note of the empty `StackPanel`, `stackTemplatePanel`, because you will refer to it in code. Add an empty event handler function for the `btnTemplate_Click` event like this:

```
private void btnTemplate_Click(object sender, RoutedEventArgs e)
{
}
```

Now your window should now look something like Figure 29-17.

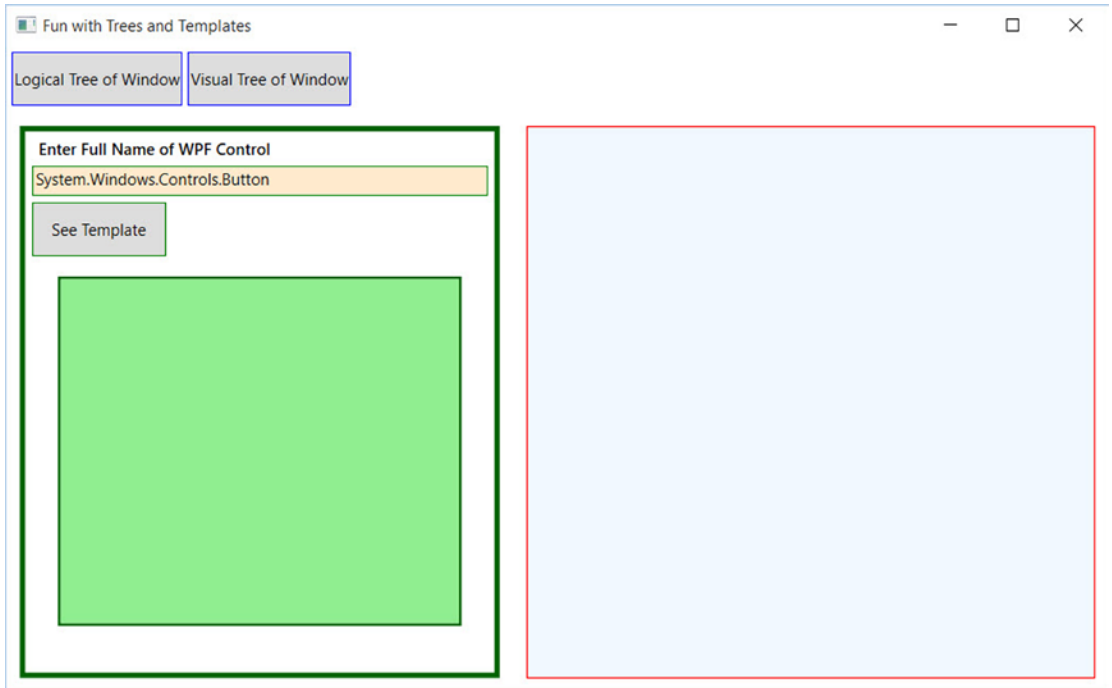

Figure 29-17. The updated UI of your window

The upper-left text area allows you to enter in the fully qualified name of a WPF control located in the `PresentationFramework.dll` assembly. Once the library is loaded, you will dynamically create an instance of the object and display it in the large square in the bottom left. Last but not least, the control's default template will be displayed in the right-hand text area. First, add a new member variable to your C# class of type `Control`, like so:

```
private Control _ctrlToExamine = null;
```

Here is the remaining code, which will require you to import the `System.Reflection`, `System.Xml`, and `System.Windows.Markup` namespaces:

```
private void btnTemplate_Click(object sender, RoutedEventArgs e)
{
    _dataToShow = "";
    ShowTemplate();
    txtDisplayArea.Text = _dataToShow;
}
```

```

private void ShowTemplate()
{
    // Remove the control that is currently in the preview area.
    if (_ctrlToExamine != null)
        stackTemplatePanel.Children.Remove(_ctrlToExamine);
    try
    {
        // Load PresentationFramework, and create an instance of the
        // specified control. Give it a size for display purposes, then add to the
        // empty StackPanel.
        Assembly asm = Assembly.Load("PresentationFramework, Version=4.0.0.0," +
            "Culture=neutral, PublicKeyToken=31bf3856ad364e35");
        _ctrlToExamine = (Control)asm.CreateInstance(txtFullName.Text);
        _ctrlToExamine.Height = 200;
        _ctrlToExamine.Width = 200;
        _ctrlToExamine.Margin = new Thickness(5);
        stackTemplatePanel.Children.Add(_ctrlToExamine);

        // Define some XML settings to preserve indentation.
        var xmlSettings = new XmlWriterSettings{Indent = true};

        // Create a StringBuilder to hold the XAML.
        var strBuilder = new StringBuilder();

        // Create an XmlWriter based on our settings.
        var xWriter = XmlWriter.Create(strBuilder, xmlSettings);

        // Now save the XAML into the XmlWriter object based on the ControlTemplate.
        XamlWriter.Save(_ctrlToExamine.Template, xWriter);

        // Display XAML in the text box.
        _dataToShow = strBuilder.ToString();
    }
    catch (Exception ex)
    {
        _dataToShow = ex.Message;
    }
}

```

The bulk of the work is just tinkering with the compiled BAML resource to map it into a XAML string. Figure 29-18 shows your final application in action, displaying the default template of the `System.Windows.Controls.DatePicker` control. The image shows the Calendar, which is accessed by clicking the button on the right-hand side of the control.

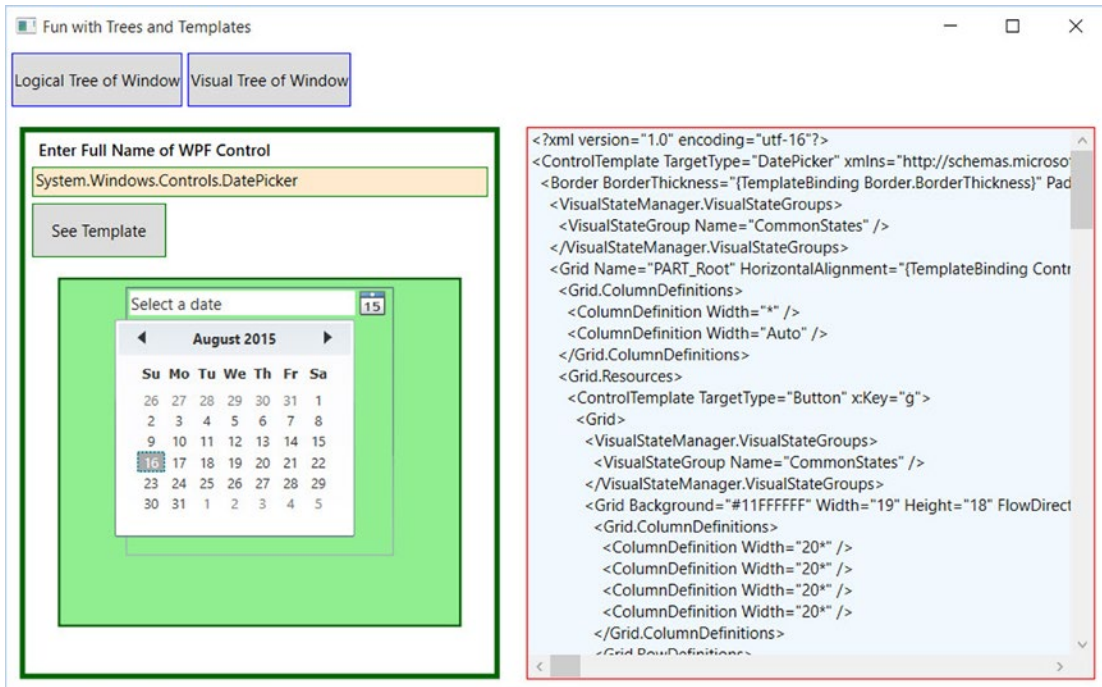

Figure 29-18. Investigating a `ControlTemplate` at runtime

Great! Hopefully you have a better idea about how logical trees, visual trees, and control default templates work together. Now you can spend the remainder of this chapter learning how to build custom templates and user controls.

■ **Source Code** The `TreesAndTemplatesApp` project is included in the Chapter 29 subdirectory.

Building a Control Template with the Trigger Framework

When you build a custom template for a control, you could do so with nothing but C# code. Using this approach, you would add data to a `ControlTemplate` object and then assign it to a control's `Template` property. Most of the time, however, you will define the look and feel of a `ControlTemplate` using XAML and add bits of code (or possibly quite a bit of code) to drive the runtime behavior.

In the remainder of this chapter, you will examine how to build custom templates using Visual Studio. Along the way, you will learn about the WPF trigger framework and the Visual State Manager (VSM), and you'll see how to use animations to incorporate visual cues for the end user. Using Visual Studio alone to build complex templates can entail a fair amount of typing and a bit of heavy lifting. To be sure, production-level templates will benefit from the use of Expression Blend for Visual Studio, the (now) free companion install to Visual Studio. However, given that this edition of the text does not include coverage of Blend, it's time to roll up your sleeves and pound out some markup.

To begin, create a new WPF application named `ButtonTemplate`. For this project, you are more interested in the mechanics of creating and using templates, so the markup for this main window is very simple.

```
<Window x:Class="ButtonTemplate.MainWindow"
  xmlns="http://schemas.microsoft.com/winfx/2006/xaml/presentation"
  xmlns:x="http://schemas.microsoft.com/winfx/2006/xaml"
  xmlns:d="http://schemas.microsoft.com/expression/blend/2008"
  xmlns:mc="http://schemas.openxmlformats.org/markup-compatibility/2006"
  xmlns:local="clr-namespace:ButtonTemplate"
  mc:Ignorable="d"
  Title="Fun with Templates" Height="350" Width="525">
  <StackPanel>
    <Button x:Name="myButton" Width="100" Height="100"
      Click="myButton_Click"/>
  </StackPanel>
</Window>
```

In the `Click` event handler, simply display a message box (via `MessageBox.Show()`) that displays a message confirming the clicking of the control. Remember, when you build custom templates, the *behavior* of the control is constant but the *look* may vary.

Currently, this `Button` is rendered using the default template, which, as the last example illustrated, is a BAML resource within a given WPF assembly. When you want to define your own template, you essentially replace this default visual tree with your own creation. To begin, update the definition of the `<Button>` element to specify a new template using the property element syntax. This template will give the control a round appearance.

```
<Button x:Name="myButton" Width="100" Height="100"
  Click="myButton_Click">
  <Button.Template>
    <ControlTemplate>
      <Grid x:Name="controlLayout">
        <Ellipse x:Name="buttonSurface" Fill = "LightBlue"/>
        <Label x:Name="buttonCaption" VerticalAlignment = "Center"
          HorizontalAlignment = "Center"
          FontWeight = "Bold" FontSize = "20" Content = "OK!"/>
      </Grid>
    </ControlTemplate>
  </Button.Template>
</Button>
```

Here, you have defined a template that consists of a named `Grid` control containing a named `Ellipse` and a `Label`. Because your `Grid` has no defined rows or columns, each child stacks on top of the previous control, allowing you to have centering of content. If you run your application now, you will notice that the `Click` event will fire *only* when the mouse cursor is within the bounds of the `Ellipse` (i.e., not in the corners around the edges of the ellipse)! This is a great feature of the WPF template architecture: you do not need to recalculate hit-testing, bounds checking, or any other low-level detail. So, if your template used a `Polygon` object to render some oddball geometry, you can rest assured that the mouse hit-testing details are relative to the shape of the control, not the larger bounding rectangle.

Templates as Resources

Currently, your template is embedded to a specific `Button` control, which limits your reuse options. Ideally, you would place your template into a resource dictionary so you can reuse your round button template between projects, or at minimum, move it into the application resource container for reuse within this project. Let's move the local `Button` resource to the application level. First, locate the `Template` property for your `Button` in the Properties editor (you'll find it under the Miscellaneous section). Now, click on the small black square icon and select "Convert to New Resource."

From the resulting dialog box, define a new template named `RoundButtonTemplate`, which is stored at the Application level (i.e., in `App.xaml`; see Figure 29-19).

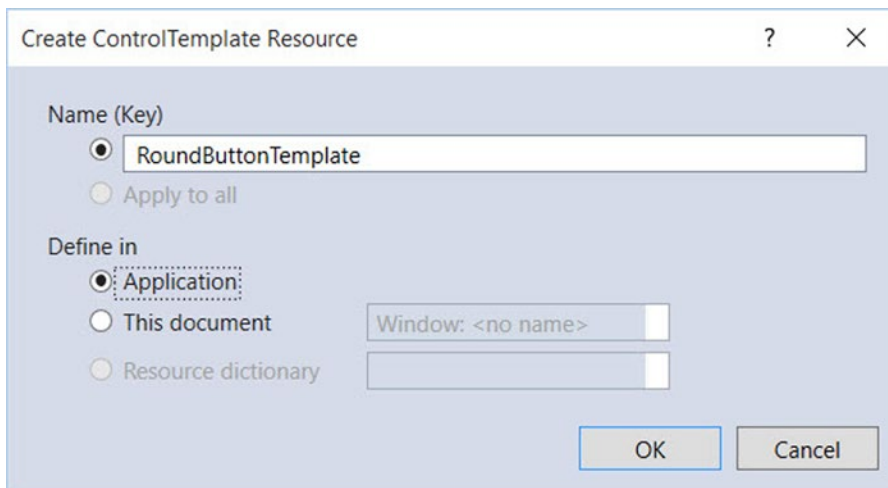

Figure 29-19. Placing your resource into `App.xaml`

At this point, you will find the following data in your `Application` object's markup:

```
<Application x:Class="ButtonTemplate.App"
  xmlns="http://schemas.microsoft.com/winfx/2006/xaml/presentation"
  xmlns:x="http://schemas.microsoft.com/winfx/2006/xaml"
  xmlns:local="clr-namespace:ButtonTemplate"
  StartupUri="MainWindow.xaml">
  <Application.Resources>
    <ControlTemplate x:Key="RoundButtonTemplate" TargetType="{x:Type Button}>
      <Grid x:Name="controlLayout">
        <Ellipse x:Name="buttonSurface" Fill = "LightBlue"/>
        <Label x:Name="buttonCaption" VerticalAlignment = "Center"
          HorizontalAlignment = "Center"
          FontWeight = "Bold" FontSize = "20" Content = "OK!"/>
      </Grid>
    </ControlTemplate>
  </Application.Resources>
</Application>
```

Now, because this resource is available for the entire application, you can define any number of round buttons. Create two additional `Button` controls that use this template for testing purposes (no need to handle the `Click` event for these new items).

```
<StackPanel>
  <Button x:Name="myButton" Width="100" Height="100"
    Click="myButton_Click"
    Template="{StaticResource RoundButtonTemplate}"></Button>
  <Button x:Name="myButton2" Width="100" Height="100"
    Template="{StaticResource RoundButtonTemplate}"></Button>
  <Button x:Name="myButton3" Width="100" Height="100"
    Template="{StaticResource RoundButtonTemplate}"></Button>
</StackPanel>
```

Visual Studio 2015 and .NET 4.6 defaults to using `DynamicResources`. I prefer `StaticResources` as the default; I move to `Dynamic` when the need arises. For these examples, make sure to change the default `DynamicResources` to `StaticResources`.

Incorporating Visual Cues Using Triggers

When you define a custom template, all of the visual cues of the default template are removed as well. For example, the default button template contains markup that informs the control how to look when certain UI events occur, such as when it receives focus, when it is clicked with the mouse, when it is enabled (or disabled), and so on. Users are quite accustomed to these sort of visual cues because it gives the control somewhat of a tactile response. However, your `RoundButtonTemplate` does not define any such markup, so the look of the control is identical regardless of the mouse activity. Ideally, your control should look slightly different when clicked (maybe via a color change or drop shadow) to let the user know the visual state has changed.

When WPF was first released, the way to add in such visual cues was to add to the template any number of triggers that would typically change values of object properties or start a storyboard animation (or both) when the trigger condition was true. By way of example, update your `RoundButtonTemplate` with the following markup, which will change the color of the control to blue and the foreground color to yellow when the mouse is over the surface:

```
<ControlTemplate x:Key="RoundButtonTemplate" TargetType="Button" >
  <Grid x:Name="controlLayout">
    <Ellipse x:Name="buttonSurface" Fill="LightBlue" />
    <Label x:Name="buttonCaption" Content="OK!" FontSize="20" FontWeight="Bold"
      HorizontalAlignment="Center" VerticalAlignment="Center" />
  </Grid>
  <ControlTemplate.Triggers>
    <Trigger Property = "IsMouseOver" Value = "True">
      <Setter TargetName = "buttonSurface" Property = "Fill" Value = "Blue"/>
      <Setter TargetName = "buttonCaption" Property = "Foreground"
        Value = "Yellow"/>
    </Trigger>
  </ControlTemplate.Triggers>
</ControlTemplate>
```

If you run the program yet again, you should find the color does toggle based on whether or not the mouse is within the `Ellipse` area. Here is another trigger, which will shrink the size of the `Grid` (and, therefore, all child elements) when the control is pressed via the mouse. Add this to your `<ControlTemplate.Triggers>` collection:

```
<Trigger Property = "IsPressed" Value="True">
  <Setter TargetName="controllayout"
    Property="RenderTransformOrigin" Value="0.5,0.5"/>
  <Setter TargetName="controllayout" Property="RenderTransform">
    <Setter.Value>
      <ScaleTransform ScaleX="0.8" ScaleY="0.8"/>
    </Setter.Value>
  </Setter>
</Trigger>
```

The Role of the `{TemplateBinding}` Markup Extension

Your template can only be applied to `Button` controls and, therefore, it would stand to reason that you could set properties on the `<Button>` element that will cause the template to render itself in a unique manner. For example, right now the `Fill` property of the `Ellipse` is hard-coded to be blue and the `Content` of the `Label` is always set to the string value "OK". If you want buttons of different colors and text values, you could define the following buttons in your main window:

```
<StackPanel>
  <Button x:Name="myButton" Width="100" Height="100"
    Background="Red" Content="Howdy!"
    Click="myButton_Click"
    Template="{StaticResource RoundButtonTemplate}" />
  <Button x:Name="myButton2" Width="100" Height="100"
    Background="LightGreen" Content="Cancel!"
    Template="{StaticResource RoundButtonTemplate}" />
  <Button x:Name="myButton3" Width="100" Height="100"
    Background="Yellow" Content="Format"
    Template="{StaticResource RoundButtonTemplate}" />
</StackPanel>
```

However, regardless of the fact that each `Button` is setting a unique `Background` and `Content` value, you still end up with three blue buttons that contain the text "OK". The problem is that the properties of the control using the template (`Button`) have properties that do not match identically with the items on the template (such as the `Fill` property of the `Ellipse`). As well, although the `Label` does have a `Content` property, the value defined in the `<Button>` scope is not automatically routed to the internal child of the template.

You can solve these issues by using the `{TemplateBinding}` markup extension when you build your template. This allows you to capture property settings defined by the control using your template and use them to set values in the template itself. Here is a reworked version of `RoundButtonTemplate`, which now uses this markup extension to map the `Background` property of the `Button` to the `Fill` property of the `Ellipse`; it also makes sure the `Content` of the `Button` is indeed passed to the `Content` property of the `Label`:

```
<ControlTemplate x:Key="RoundButtonTemplate" TargetType="Button">
  <Grid x:Name="controllayout">
    <Ellipse x:Name="buttonSurface" Fill="{TemplateBinding Background}"/>
```

```

    <Label x:Name="buttonCaption" Content="{TemplateBinding Content}"
        FontSize="20" FontWeight="Bold"
        HorizontalAlignment="Center" VerticalAlignment="Center" />
</Grid>
<ControlTemplate.Triggers>
    ...
</ControlTemplate.Triggers>
</ControlTemplate>

```

With this update, you can now create buttons of various colors and textual values (see Figure 29-20). The example XAML is shown here:

```

<Button x:Name="myButton" Width="100" Height="100" Background="Red" Content="Howdy!"
    Click="myButton_Click" Style="{StaticResource RoundButtonStyle}" />
<Button x:Name="myButton2" Width="100" Height="100" Background="LightGreen" Content="Cancel!"
    Style="{StaticResource RoundButtonStyle}" />
<Button x:Name="myButton3" Width="100" Height="100" Background="Yellow" Content="Format"
    Style="{StaticResource RoundButtonStyle}" />

```

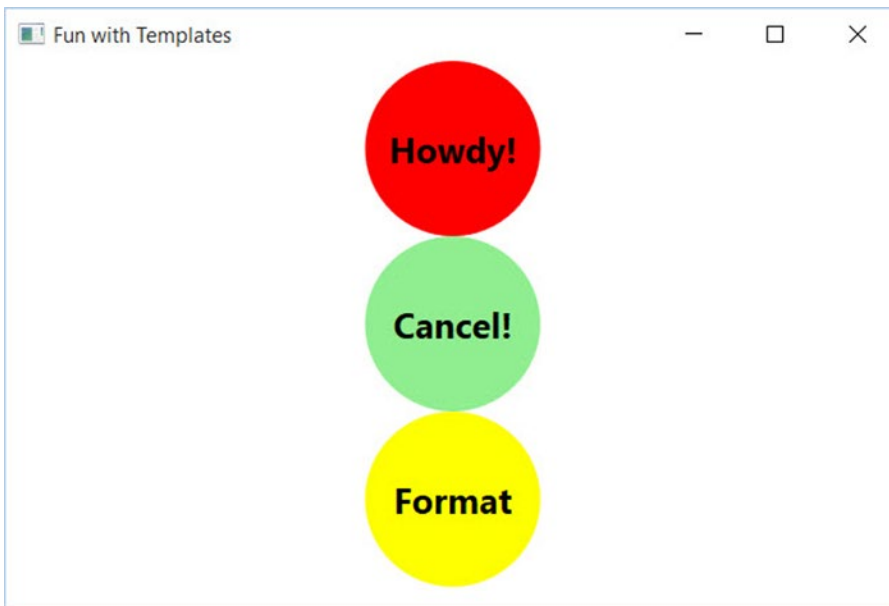

Figure 29-20. Template bindings allow values to pass through to the internal controls

The Role of ContentPresenter

When you designed your template, you used a `Label` to display the textual value of the control. Like the `Button`, the `Label` supports a `Content` property. Therefore, given your use of `{TemplateBinding}`, you could define a `Button` that contains complex content beyond that of a simple string. For example,

```
<Button x:Name="myButton4" Width="100" Height="100" Background="Yellow"
        Template="{StaticResource RoundButtonTemplate}">
  <Button.Content>
    <ListBox Height="50" Width="75">
      <ListBoxItem>Hello</ListBoxItem>
      <ListBoxItem>Hello</ListBoxItem>
      <ListBoxItem>Hello</ListBoxItem>
    </ListBox>
  </Button.Content>
</Button>
```

For this particular control, things work just as hoped. However, what if you need to pass in complex content to a template member that does *not* have a Content property? When you want to define a generalized *content display area* in a template, you can use the ContentPresenter class as opposed to a specific type of control (Label or TextBlock). There is no need to do so for this example; however, here is some simple markup that illustrates how you could build a custom template that uses ContentPresenter to show the value of the Content property of the control using the template:

```
<!-- This button template will display whatever is set
      to the Content of the hosting button. -->
<ControlTemplate x:Key="NewRoundButtonTemplate" TargetType="Button">
  <Grid>
    <Ellipse Fill="{TemplateBinding Background}"/>
    <ContentPresenter HorizontalAlignment="Center"
                    VerticalAlignment="Center"/>
  </Grid>
</ControlTemplate>
```

Incorporating Templates into Styles

Currently, your template simply defines a basic look and feel of the Button control. However, the process of establishing the basic properties of the control (content, font size, font weight, etc.) is the responsibility of the Button itself.

```
<!-- Currently the Button must set basic property values, not the template. -->
<Button x:Name="myButton" Foreground="Black" FontSize="20" FontWeight="Bold"
        Template="{StaticResource RoundButtonTemplate}" Click="myButton_Click"/>
```

If you want, you could establish these values *in the template*. By doing so, you can effectively create a default look and feel. As you might have already realized, this is a job for WPF styles. When you build a style (to account for basic property settings), you can define a template *within the style*! Here is your updated application resource in the application resources in App.xaml, which has been rekeyed as RoundButtonStyle:

```
<!-- A style containing a template. -->
<Style x:Key="RoundButtonStyle" TargetType="Button">
  <Setter Property="Foreground" Value="Black"/>
  <Setter Property="FontSize" Value="14"/>
  <Setter Property="FontWeight" Value="Bold"/>
  <Setter Property="Width" Value="100"/>
  <Setter Property="Height" Value="100"/>
```

```

<!-- Here is the template! -->
<Setter Property ="Template">
  <Setter.Value>
    <ControlTemplate TargetType ="Button">
      <Grid x:Name="controlLayout">
        <Ellipse x:Name="buttonSurface" Fill="{TemplateBinding Background}"/>
        <Label x:Name="buttonCaption" Content ="{TemplateBinding Content}"
          HorizontalAlignment="Center" VerticalAlignment="Center" />
      </Grid>
      <ControlTemplate.Triggers>
        <Trigger Property = "IsMouseOver" Value = "True">
          <Setter TargetName = "buttonSurface" Property = "Fill" Value = "Blue"/>
          <Setter TargetName = "buttonCaption" Property = "Foreground" Value = "Yellow"/>
        </Trigger>
        <Trigger Property = "IsPressed" Value="True">
          <Setter TargetName="controlLayout"
            Property="RenderTransformOrigin" Value="0.5,0.5"/>
          <Setter TargetName="controlLayout" Property="RenderTransform">
            <Setter.Value>
              <ScaleTransform ScaleX="0.8" ScaleY="0.8"/>
            </Setter.Value>
          </Setter>
        </Trigger>
      </ControlTemplate.Triggers>
    </ControlTemplate>
  </Setter.Value>
</Setter>
</Style>

```

With this update, you can now create button controls by setting the `Style` property as so:

```

<Button x:Name="myButton" Background="Red" Content="Howdy!"
  Click="myButton_Click" Style="{StaticResource RoundButtonStyle}"/>

```

While the rendering and behavior of the button are identical, the benefit of nesting templates within styles is that you are able to provide a canned set of values for common properties. That wraps up your look at how to use Visual Studio and the trigger framework to build custom templates for a control. While there is still much more about the Windows Presentation Foundation API than has been examined here, you should be in a solid position for further study.

■ **Source Code** The `ButtonTemplate` project can be found in the [Chapter 29](#) subdirectory.

Summary

The first part of this chapter examined the resource management system of WPF. You began by looking at how to work with binary resources, and then you examined the role of object resources. As you learned, object resources are named blobs of XAML that can be stored at various locations in order to reuse content.

Next, you learned about WPF's animation framework. Here you had a chance to create some animations using C# code, as well as with XAML. You learned that if you define an animation in markup, you use <Storyboard> elements and triggers to control execution. You then looked at the WPF style mechanism, which makes heavy use of graphics, object resources, and animations.

You examined the relationship between a *logical tree* and a *visual tree*. The logical tree is basically a one-to-one correspondence of the markup you author to describe a WPF root element. Behind this logical tree is a much deeper visual tree that contains detailed rendering instructions.

The role of a *default template* was then examined. Remember, when you are building custom templates, you are essentially ripping out all (or part) of a control's visual tree and replacing it with your own custom implementation.

CHAPTER 30



Notifications, Commands, Validation, and MVVM

This chapter will conclude your investigation of the WPF programming model by introducing you to the Observable pattern and the notification system built into WPF. You'll also expand your knowledge of commands and validation. These three items are the foundation for implementing the Model-View-ViewModel (MVVM) pattern in WPF.

The first section covers observable models and observable collections. When classes and collections implement `INotifyPropertyChanged` and `INotifyCollectionChanged` (respectively), the binding manager keeps the values in the UI in sync with the bound data. Having the data in the UI accurately portray the current state of the data automatically improves the user experience significantly and reduces the manual coding required in older technologies (such as WinForms) to achieve the same result.

Building on the Observable pattern, you will examine the mechanisms to add validation into your application. Validation is a vital part of any application—not only letting the user know that something is wrong, but also letting them know *what* is wrong. To inform the user what the error is, you will also learn how to incorporate validation into the view markup.

Next, you will take a deeper dive into the WPF command system and create custom commands to encapsulate program logic, much as you did in Chapter 27 with the built-in commands. There are several advantages to creating custom commands, including (but not limited to) enabling code reuse, logic encapsulation, and cleaner code.

Finally, you will learn about the Model-View-ViewModel (MVVM) pattern, and how all of this material fits together to support the pattern. Figure 30-1 shows the application that you will build throughout this chapter.

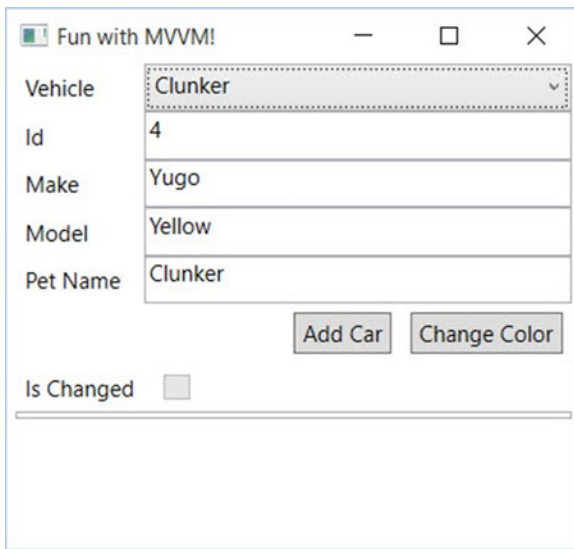

Figure 30-1. *Fun with MVVM!*

Introducing Model-View-ViewModel

Before you dive into notifications, validations, and commands in WPF, it would be good to understand the end goal of this chapter, which is the Mode-View-ViewModel pattern (MVVM).

Derived from Martin Fowler’s Presentation Model pattern, MVVM leverages the XAML-specific capabilities, discussed in this chapter, to make your WPF development faster and cleaner. The name itself describes the main components of the pattern: Model, View, ViewModel.

Model

The Model is the object representation of your data. In the samples from this chapter, the Model is the Inventory class. This doesn’t mean the actual data store (such as SQL Server), but the classes that *represent* the data that is stored in the persistence layer.

Models usually have validation built in (as you will see later in this chapter in the Validation section) and are configured as observables, covered later in this chapter as well.

View

The View is the UI of the application, and it is designed to be very lightweight. Think of the menu board at a drive-thru restaurant. The board displays menu items and prices, and it has a mechanism so the user can communicate with the back-end systems. However, there isn’t any intelligence built into the board, unless it is isolated from the restaurant itself, in which case it might have a light sensor that will turn on the lights if it gets dark.

MVVM Views should be developed with the same goals in mind. Any intelligence should be built into the application elsewhere. The only code in the code-behind file (e.g. `MainWindow.xaml.cs`) should be directly related to manipulating the UI. It should not be based on business rules or anything that needs to be persisted for future use. While not the goal of MVVM, very little code in the code-behind (if any) is a pleasant side effect.

ViewModel

In WPF and other XAML technologies, the ViewModel serves two purposes:

- The ViewModel provides a single stop for all of the data needed by the view. This doesn't mean that the ViewModel is responsible for getting the actual data; instead it calls the relevant code (such as EF repositories) to get all of the data together where it's easily accessible. Because of this, there is typically a one-to-one correlation between Windows and ViewModels in my code, but architectural differences exist, and your mileage may vary.
- The second job is to act as the controller for the View. Just like the menu board, the ViewModel takes direction from the user, and calls the code to make sure the proper actions are taken. This code is typically in the form of commands.

Anemic Models or ViewModels

In the early days of WPF, when developers were still working out how best to implement the MVVM pattern, there were significant (and sometimes heated) discussions about *where* to implement items like validation and the observable patterns. One camp (the Anemic Model camp) argued that it all should be in the ViewModel, since adding those capabilities to the model broke separation of concerns. The other camp (the Anemic ViewModel camp) argued it should all be in the Models, since that reduced duplication of code.

The real answer is, of course, it depends. When `INotifyPropertyChanged`, `IDataErrorInfo`, and `INotifyDataErrorInfo` are implemented on the model classes, this ensures that the relevant code is close to the target of the code (as you will see in this chapter), and is only implemented once for each model. That being said, there are times when your ViewModel classes will need to be developed as observables themselves. At the end of the day, you need to determine what makes the most sense, without over-complicating your code or sacrificing the benefits of MVVM.

■ **Note** There are multiple MVVM frameworks available for WPF, such as `MVVMLite`, `Caliburn.Micro`, and `Prism` (although `Prism` is much more than just an MVVM framework). Each framework has its merits and (to some extent) detractions. This chapter discusses the MVVM pattern and the features in WPF that support implementing the pattern. I leave it to you, the reader, to examine the different frameworks and select the one that best matches your app needs.

The WPF Binding Notification System

A significant shortcoming in the binding system for WinForms is a lack of notifications. If the data in the data source changes, the UI does not get automatically updated. Instead, the developer needs to call `Refresh` on the control before the control will reload the data from the data source. This can lead to more calls to `Refresh` than are actually necessary because most developers want to make sure the UI and the data do not get out of sync. While not a significant performance issue to include too many, if you don't include enough, the experience for the user could be affected negatively.

The binding system built into XAML-based applications corrects this problem by enabling you to hook your data objects into a notification system. Classes and collections that hook into this system are referred to as observable models and observable collections, or collectively as observables. Whenever a property's value changes on an observable model or the collection changes (e.g. items are added, removed, or reordered) on an observable collection, they raise an event (either `NotifyPropertyChanged` or `NotifyCollectionChanged`).

The binding framework automatically listens for those events to occur, and updates the bound controls when they fire. Even better, as a developer, you have control over which properties raise the notifications. Sounds perfect, right? Well, it's not *quite* perfect, as you shall soon see. There is a fair amount of code involved in setting this up for observable models if you are doing it all by hand. Fortunately, there is an open source framework that makes it much simpler, as you shall soon see.

Observable Models and Collections

In this section, you will create an application that uses observable models and collections. To get started, create a new WPF application named Notifications. The form will be a Master Detail form, allowing the user to select a specific car using the ComboBox, and then the details for that car will be displayed in the TextBoxes below. Update `MainWindow.xaml` to the following markup:

```
<Window x:Class="Notifications.MainWindow"
  xmlns="http://schemas.microsoft.com/winfx/2006/xaml/presentation"
  xmlns:x="http://schemas.microsoft.com/winfx/2006/xaml"
  xmlns:d="http://schemas.microsoft.com/expression/blend/2008"
  xmlns:mc="http://schemas.openxmlformats.org/markup-compatibility/2006"
  xmlns:local="clr-namespace:Notifications"
  mc:Ignorable="d"
  Title="Fun with Notifications!" Height="225" Width="325"
  WindowStartupLocation="CenterOwner">
<Grid IsSharedSizeScope="True" Margin="5,0,5,5">
  <Grid.RowDefinitions>
    <RowDefinition Height="Auto"/>
    <RowDefinition Height="Auto"/>
  </Grid.RowDefinitions>
  <Grid Grid.Row="0">
    <Grid.ColumnDefinitions>
      <ColumnDefinition Width="Auto" SharedSizeGroup="CarLabels"/>
      <ColumnDefinition Width="*/>
    </Grid.ColumnDefinitions>
    <Label Grid.Column="0" Content="Vehicle"/>
    <ComboBox Name="cboCars" Grid.Column="1" DisplayMemberPath="PetName" />
  </Grid>
  <Grid Grid.Row="1">
    <Grid.ColumnDefinitions>
      <ColumnDefinition Width="Auto" SharedSizeGroup="CarLabels"/>
      <ColumnDefinition Width="*/>
    </Grid.ColumnDefinitions>
    <Grid.RowDefinitions>
      <RowDefinition Height="Auto"/>
      <RowDefinition Height="Auto"/>
      <RowDefinition Height="Auto"/>
      <RowDefinition Height="Auto"/>
    </Grid.RowDefinitions>
    <Label Grid.Column="0" Grid.Row="0" Content="Make"/>
    <TextBox Grid.Column="1" Grid.Row="0" />
    <Label Grid.Column="0" Grid.Row="1" Content="Color"/>
    <TextBox Grid.Column="1" Grid.Row="1" />
    <Label Grid.Column="0" Grid.Row="2" Content="Pet Name"/>
```

```

<TextBox Grid.Column="1" Grid.Row="2" />
<StackPanel Grid.Column="0" Grid.ColumnSpan="2" Grid.Row="3"
    HorizontalAlignment="Right" Orientation="Horizontal" Margin="0,5,0,5">
    <Button x:Name="btnAddCar" Content="Add Car" Margin="5,0,5,0" Padding="4, 2" />
    <Button x:Name="btnChangeColor" Content="Change Color" Margin="5,0,5,0"
        Padding="4, 2"/>
</StackPanel>
</Grid>
</Grid>
</Window>

```

Your window will resemble Figure 30-2.

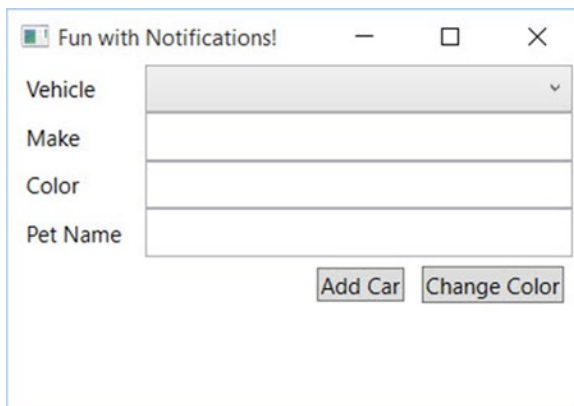

Figure 30-2. Master Detail window displaying inventory details

Next, right-click the project name in Solution Explorer, select Add ► New Folder named Models, and in this new folder, create a class named Inventory. The initial class is listed here:

```

public class Inventory
{
    public int CarId { get; set; }
    public string Make { get; set; }
    public string Color { get; set; }
    public string PetName { get; set; }
}

```

Adding Bindings and Data

The next step is to add the binding statements for the controls. To do this, add a DataContext to the Grid holding the text boxes and label. Set the DataContext to the SelectedItem property of the ComboBox. Update the Grid that holds the detail controls to the following:

```

<Grid Grid.Row="1" DataContext="{Binding ElementName=cboCars, Path=SelectedItem}">

```

As a reminder, controls will navigate *up* the element tree for a `DataContext` if one isn't specified. This enables you to just specify the path for the binding in the `TextBoxes`. Add the appropriate text attributes and related bindings to the `TextBoxes`, like so:

```
<TextBox Grid.Column="1" Grid.Row="0" Text="{Binding Path=Make}" />
<TextBox Grid.Column="1" Grid.Row="1" Text="{Binding Path=Color}" />
<TextBox Grid.Column="1" Grid.Row="2" Text="{Binding Path=PetName}" />
```

Finally, add data to the `ComboBox`. In `MainWindow.xaml.cs`, create a new list of `Inventory` records, and set the `ItemsSource` for the `ComboBox` to the list. Also add the using statement for the `Notifications.Models` namespace.

```
using Notifications.Models;
public class MainWindow : Window
{
    readonly IList<Inventory> _cars;
    public MainWindow()
    {
        InitializeComponent();
        _cars = new List<Inventory>
        {
            new Inventory {CarId=1,Color="Blue",Make="Chevy",PetName="Kit" },
            new Inventory {CarId=2,Color="Red",Make="Ford",PetName="Red Rider" },
        };
        cboCars.ItemsSource = _cars;
    }
}
```

Run the app. You'll see that the vehicle selector has two cars to choose from. Choose one of them, and the text boxes will be automatically populated with the vehicle detail, as shown in Figure 30-3. Change the color of one of the vehicles, select the other vehicle, and then go back to the vehicle you edited. You will see the new color is indeed still attached to the vehicle. This isn't anything remarkable; you've seen the power of XAML databinding in previous examples.

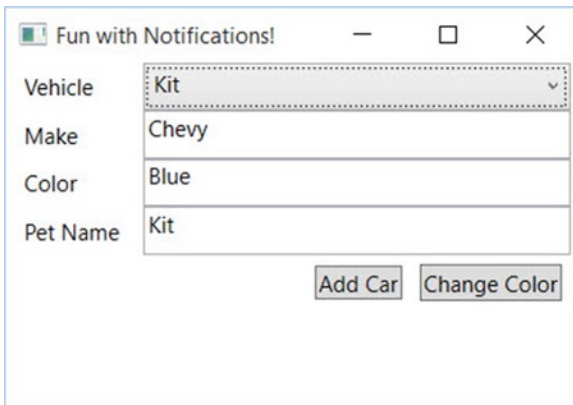

Figure 30-3. The window with data

Programmatically Changing the Vehicle Data

While the previous example works as expected, if the data is changed programmatically, the UI will *not* reflect the changes unless you program the app to refresh the data. To demonstrate this, add an event handler for the `btnChangeColor` Button, like so:

```
<Button x:Name="btnAddCar" Content="Add Car" Margin="5,0,5,0" Padding="4, 2"
Click="btnAddCar_Click"/>
```

Create (or have Visual Studio create it for you) the event handler for the `btnChangeColor_Click` event, as follows:

```
private void btnChangeColor_Click(object sender, RoutedEventArgs e)
{
}
```

In the event handler, use the `SelectedItem` property of the `ComboBox` to locate the selected record from the cars list. If a match is found, change the color to Pink. The code is listed here:

```
private void btnChangeColor_Click(object sender, RoutedEventArgs e)
{
    var car = _cars.FirstOrDefault(x => x.CarId == ((Inventory)cboCars.SelectedItem)?.CarId);
    if (car != null)
    {
        car.Color = "Pink";
    }
}
```

Run the app, select a vehicle, and click the Change Color button. Nothing changes visibly. Select the other vehicle and go back to your originally selected vehicle. Now you will see the updated value. This is not a very good experience for the user!

Now add an event handler to the `btnAddCar` button, like this:

```
<Button x:Name="btnAddCar" Content="Add Car" Margin="5,0,5,0" Padding="4,2"
Click="btnAddCar_Click"/>
```

Add the event handler (or let Visual Studio create it for you) for the `btnAddCar_Click` event handler, like this:

```
private void btnAddCar_Click(object sender, RoutedEventArgs e)
{
}
```

In the `btnAddCar_Click` event handler, add a new record to the `Inventory` list.

```
private void btnAddCar_Click(object sender, RoutedEventArgs e)
{
    var maxCount = _cars?.Max(x => x.CarId) ?? 0;
    _cars?.Add(new Inventory { CarId=++maxCount,Color="Yellow",Make="VW",PetName="Birdie"});
}
```

Run the app, click the Add Car button, and examine the contents of the ComboBox. Even though you know there are three cars in the list, only two are displayed!

To correct both of these problems, you will use observable models and an observable collection. These changes are covered in the next sections.

Observable Models

The problem of data changing on a property of your model and not being displayed in the UI is resolved by implementing the `INotifyPropertyChanged` interface on your `Inventory` model class. The `INotifyPropertyChanged` interface only exposes a single event: the `PropertyChangedEvent`. The XAML binding engine listens for this event for each bound property as long as the class implements the `INotifyPropertyChanged` interface. The interface is shown here:

```
public interface INotifyPropertyChanged
{
    event PropertyChangedEventHandler PropertyChanged;
}
```

The `PropertyChanged` event takes an object reference and a new instance of the `PropertyChangedEventArgs` class, like this:

```
PropertyChanged?.Invoke(this, new PropertyChangedEventArgs("Model"));
```

The first parameter is the object instance that is raising the event. The `PropertyChangedEventArgs` constructor takes a string that indicates the property that was changed and needs to be updated. When the event is raised, the binding engine looks for any controls bound the named property on that instance. If you pass `string.Empty` into the `PropertyChangedEventArgs`, all of the bound properties of the instance are updated.

You control which properties are enlisted in the automatic updates by raising the `PropertyChanged` event in the setter for the properties that you want to have automatically updated. This is usually all of the properties on your model classes, but you have the option of omitting certain properties based on your application's requirements. Instead of raising the event directly in the setter for each of the enlisted properties, a common pattern is to create a helper method (typically named `OnPropertyChanged`) that raises the event on behalf of the properties, usually in a base class for your models.

In versions of .NET prior to 4.5, you had to pass the string name of the property into your helper method. If the property name of your class changed, you had to remember to update the string passed into helper method, or the update would not work. Starting in .NET 4.5, you can take advantage of the `[CallerMemberName]` attribute. This attribute assigns the name of the method (your property setter) that calls into your helper method to the `propertyName` parameter. Add a method to the `Inventory` class (named `OnPropertyChanged`) and raise the `PropertyChangedEvent` like this:

```
internal void OnPropertyChanged([CallerMemberName] string propertyName = "")
{
    PropertyChanged?.Invoke(this, new PropertyChangedEventArgs(propertyName));
}
```

Next, update each of the automatic properties in the Inventory class to have a full getter and setter with a backing field. When the value is changed, call the `OnPropertyChanged` helper method. Here is the `CarId` property updated:

```
private int _carId;
public int CarId
{
    get { return _carId; }
    set
    {
        if (value == _carId) return;
        _carId = value;
        OnPropertyChanged();
    }
}
```

There have been several changes to the Inventory class, including implementing the `INotifyPropertyChanged` event, raising the `PropertyChanged` event, and converting all of the automatic properties to explicit properties with backing fields. The updated class is listed here:

```
using System.ComponentModel;
using System.Runtime.CompilerServices;
namespace Notifications.Models
{
    public class Inventory : INotifyPropertyChanged
    {
        private int _carId;
        public int CarId
        {
            get { return _carId; }
            set
            {
                if (value == _carId) return;
                _carId = value;
                OnPropertyChanged();
            }
        }
        private string _make;
        public string Make
        {
            get { return _make; }
            set
            {
                if (value == _make) return;
                _make = value;
                OnPropertyChanged();
            }
        }
    }
}
```

```

private string _color;
public string Color
{
    get { return _color; }
    set
    {
        if (value == _color) return;
        _color = value;
        OnPropertyChanged();
    }
}

private string _petName;
public string PetName
{
    get { return _petName; }
    set
    {
        if (value == _petName) return;
        _petName = value;
        OnPropertyChanged();
    }
}

public event PropertyChangedEventHandler PropertyChanged;

internal void OnPropertyChanged([CallerMemberName] string propertyName = "")
{
    PropertyChanged?.Invoke(this, new PropertyChangedEventArgs(propertyName));
}
}
}

```

Run the app again. Select a vehicle and click the Change Color button. You will immediately see the change show up in the UI. First problem solved!

Using nameof

A new feature in C# 6 is the `nameof` operator, which provides the string name of the item passed into the `nameof` method. You can use this in the calls to `OnPropertyChanged` in your setters, like this:

```

private string _color;
public string Color
{
    get { return _color; }
    set
    {
        if (value == _color) return;
        _color = value;
        OnPropertyChanged(nameof(Color));
    }
}

```

Note that you don't have to remove the `CallerMemberName` attribute from the `OnPropertyChanged` when you use the `nameof` method (although it becomes unnecessary). In the end, whether you use the `nameof` method or the `CallerMemberName` attribute comes down to a matter of personal choice.

Observable Collections

The next problem to resolve is updating the UI when the contents of a collection change. This is done by implementing the `INotifyCollectionChanged` interface. Like the `INotifyPropertyChanged` interface, this interface exposes one event, the `CollectionChanged` event. Unlike the `INotifyPropertyChanged` event, implementing this interface by hand is more than just calling a method in the setter. You need to create a full `List` implementation and raise the `CollectionChanged` event any time your list changes.

The `CollectionChanged` event takes one parameter, a new instance of the `CollectionChangedEventArgs`. The `CollectionChangedEventArgs` takes one or more parameters in its constructor, based on the operation. The first parameter is always one of the `NotifyCollectionChangedAction` enum values, which informs the binding engine what changed with the list. The values for the `NotifyCollectionChangedAction` enum are shown in Table 30-1.

Table 30-1. *NotifyCollectionChangedAction enum Values*

| Member | Meaning in Life |
|---------|--|
| Add | One or more times were added to the collection. |
| Move | One or more items moved in the collection. |
| Remove | One or more items were removed from the collection. |
| Replace | One or more items were replaced in the collection. |
| Reset | So much changed that the best option is to start over and rebind everything related to the collection. |

The options for the constructor of the `NotifyCollectionChangedEventArgs` vary based on the action being announced. Table 30-2 lists the operations and the additional parameters sent into the constructor.

Table 30-2. *NotifyCollectionChangedEventArgs Constructor Options*

| Operation | Additional Parameters |
|------------------|---|
| Reset | None |
| Add (single) | Item to be added, [optional] index of location for add |
| Add (List) | Items to be added, [optional] index of location for add |
| Remove (single) | Item to be removed, [optional] index of item to be removed |
| Remove (List) | Items to be removed, [optional] start index of location for removal |
| Move (Single) | Item to be moved, original index, destination index |
| Move (List) | Items to be moved, start original index, destination index |
| Replace (single) | Item to be added, item to be removed, [optional] index of change |
| Replace (List) | Items to be added, items to be removed, [optional] starting index of change |

There are a lot of variations in play here. The next section shows the options that apply to an `IList<T>` in action.

Building Custom `IList<Inventory>`

To see an example of this, create a new class in your `Models` directory and name the class `InventoryList`. Implement the `IList<Inventory>` and `INotifyCollectionChanged` interfaces, which when stubbed out, result in the following code:

```
public class InventoryList : IList<Inventory>, INotifyCollectionChanged
{
    public IEnumerator<Inventory> GetEnumerator()
    {
        throw new System.NotImplementedException();
    }

    IEnumerator IEnumerable.GetEnumerator()
    {
        return GetEnumerator();
    }

    public void Add(Inventory item)
    {
        throw new System.NotImplementedException();
    }

    public void Clear()
    {
        throw new System.NotImplementedException();
    }

    public bool Contains(Inventory item)
    {
        throw new System.NotImplementedException();
    }

    public void CopyTo(Inventory[] array, int arrayIndex)
    {
        throw new System.NotImplementedException();
    }

    public bool Remove(Inventory item)
    {
        throw new System.NotImplementedException();
    }

    public int Count { get; }
    public bool IsReadOnly { get; }
```

```

public int IndexOf(Inventory item)
{
    throw new System.NotImplementedException();
}

public void Insert(int index, Inventory item)
{
    throw new System.NotImplementedException();
}

public void RemoveAt(int index)
{
    throw new System.NotImplementedException();
}

public Inventory this[int index]
{
    get { throw new System.NotImplementedException(); }
    set { throw new System.NotImplementedException(); }
}

public event NotifyCollectionChangedEventHandler CollectionChanged;
}

```

Start updating this class by adding a helper method named `OnCollectionChanged` for the `CollectionChanged` event. In this method, if the `CollectionChanged` is not null, invoke it, like this:

```

public event OnCollectionChangedEventHandler CollectionChanged;
private void OnCollectionChanged(NotifyCollectionChangedEventArgs args)
{
    CollectionChanged?.Invoke(this, args);
}

```

Next, add a private field named `_inventories` of type `IList<Inventory>`, and a new constructor that takes an `IList<Inventory>` and initializes the field, like this:

```

private readonly IList<Inventory> _inventories;
public InventoryList(IList<Inventory> inventories)
{
    _inventories = inventories;
}

```

Next, add in some of the plumbing methods for list. These methods don't change the state of the list, but are necessary for implementing `IList<T>`, and are shown here:

```

public IEnumerator<Inventory> GetEnumerator() => _inventories.GetEnumerator();

IEnumerator IEnumerable.GetEnumerator() => GetEnumerator();

public bool Contains(Inventory item) => _inventories.Contains(item);

```

```

public void CopyTo(Inventory[] array, int arrayIndex)
{
    _inventories.CopyTo(array, arrayIndex);
}

public int Count => _inventories.Count;

public bool IsReadOnly => _inventories.IsReadOnly;

public int IndexOf(Inventory item) => _inventories.IndexOf(item);

```

The first method to flush out is the `Add` method. Add the item to the `_inventories` list, and call the `OnCollectionChanged` method, passing in the `NotificationCollectionChangedAction.Add` value and the new item to be added. The updated code is shown here:

```

public void Add(Inventory item)
{
    _inventories.Add(item);
    OnCollectionChanged(new NotifyCollectionChangedEventArgs(NotifyCollectionChangedAction.
        Add, item));
}

```

The `Insert` method adds a record at a specified index. In the method, insert the item to the `_inventories` list at the correct index. Then call the `OnCollectionChanged` method, passing in the `NotificationCollectionChangedAction.Add` value, the new item to be added, and the index of the change. The updated code is shown here:

```

public void Insert(int index, Inventory item)
{
    _inventories.Insert(index, item);
    OnCollectionChanged(new NotifyCollectionChangedEventArgs(NotifyCollectionChangedAction.
        Add, item, index));
}

```

To execute a `replace-with-the-indexer` method, pass in the `NotifyCollectionChangedAction.Replace` value in the `OnCollectionChanged` call and the updated item:

```

public Inventory this[int index]
{
    get { return _inventories?[index]; }
    set
    {
        _inventories[index] = value;
        OnCollectionChanged(new NotifyCollectionChangedEventArgs(
            NotifyCollectionChangedAction.Replace, _inventories[index]));
    }
}

```

Next, update the `Remove` method. Remove the item from the `_inventories` list, and call the `OnCollectionChanged` method, passing in the `NotificationCollectionChangedAction.Remove` value and the item to be removed. The updated code is shown here:

```
public bool Remove(Inventory item)
{
    var removed = _inventories.Remove(item);
    if (removed)
    {
        OnCollectionChanged(new NotifyCollectionChangedEventArgs(
            NotifyCollectionChangedAction.Remove, item));
    }
    return removed;
}
```

Next, update the `RemoveAt` method. The `RemoveAt` method on the `ICollection<T>` interface only accepts an index, and there isn't a version of the `NotifyCollectionEventArgs` constructor that takes just an index. Therefore, you need to get a reference to the correct object from the `_inventories` list first, before removing it from the list. Next, remove the item from the `_inventories` list using the supplied index value. Finally, call the `OnCollectionChanged` method, passing in the `NotificationCollectionChangedAction.Remove` value, the item to be removed, and the index.

■ **Note** If you did not get a reference to the correct object, you have to pass `NotifyCollectionChangedEventArgs.Reset` to the event, which could have a performance impact, since it refreshes everything in the UI that is bound to this list.

The updated code is shown here:

```
public void RemoveAt(int index)
{
    var itm = _inventories[index];
    _inventories.RemoveAt(index);
    OnCollectionChanged(new NotifyCollectionChangedEventArgs(
        NotifyCollectionChangedAction.Remove, itm, index));
}
```

Finally, update the `Clear` method. Since this is completely changing the list, you pass in `NotificationCollectionChangedAction.Reset`, as shown here:

```
public void Clear()
{
    _inventories.Clear();
    OnCollectionChanged(new NotifyCollectionChangedEventArgs(NotifyCollectionChangedAction.Reset));
}
```

Now that you have created a custom `IList<Inventory>` that also implements `INotifyCollectionChanged`, it's time to use it in your app. Open up `MainForm.xaml.cs`, and change the type of the `_cars` variable to `InventoryList` and update the constructor to create a new `InventoryList`, as follows:

```
private readonly InventoryList _cars;
public MainWindow()
{
    InitializeComponent();
    _cars = new InventoryList(new List<Inventory>
    {
        //IsChanged must be last in the list
        new Inventory {CarId=1,Color="Blue",Make="Chevy",PetName="Kit", IsChanged = false},
        new Inventory {CarId=2,Color="Red",Make="Ford",PetName="Red Rider", IsChanged =
            false },
    });
    cboCars.ItemsSource = _cars;
}
```

Run the app, click the Add Car button, and verify that the number of cars in the combo box does indeed increase. Now test removing records by adding a new button after the Change Color button. Name the new button `btnRemoveCar`, set the content to "Remove Car", and set the Click event to `btnRemoveCar_Click`, as follows:

```
<Button x:Name="btnRemoveCar" Content="Remove Car" Margin="5,0,5,0" Padding="4,2"
Click="btnRemoveCar_Click"/>
```

Create the event handler (or let Visual Studio create it for you), and add a call to remove the first record from the `_cars` list. The code is listed here:

```
private void btnRemoveCar_Click(object sender, RoutedEventArgs e)
{
    _cars.RemoveAt(0);
}
```

Run the app, click the Remove Car button, and verify that the number of cars in the combo box does indeed decrease. The problem of collections changing and not updating the UI is indeed solved, but that was a fair amount of code to write.

Using ObservableCollection

Fortunately, there is a much easier way than creating your own collections. The `ObservableCollection<T>` class implements `INotifyCollectionChanged`, `INotifyPropertyChanged`, and `Collection<T>`, and it is part of the framework. No extra work! To demonstrate this, add a `using` statement for `System.Collections.ObjectModel`, then update the private field for `_cars` and the constructor in `MainWindow.xaml.cs` to the following:

```
readonly ObservableCollection<Inventory> _cars;
public MainWindow()
{
    InitializeComponent();
    _cars = new ObservableCollection<Inventory>
```

```

{
    new Inventory {CarId=1,Color="Blue",Make="Chevy",PetName="Kit" },
    new Inventory {CarId=2,Color="Red",Make="Ford",PetName="Red Rider" },
};
cboCars.ItemsSource = _cars;
}

```

Run the app again, and click the Add Car and Remove Car buttons. You will see the new records appear (and disappear) appropriately.

Implementing a Dirty Flag

Another advantage of observable models is tracking state changes. While some Object Relational Mappers (ORMs) like Entity Framework provide some rudimentary state tracking, with observable models, dirty tracking (tracking when one or more of an object's values have changed) is trivial. Add a bool property named `IsChanged` to the `Inventory` class. Make sure to call `OnPropertyChanged` just like the other properties in the `Inventory` class.

```

private bool _isChanged;
public bool IsChanged {
    get { return _isChanged;}
    set
    {
        if (value == _isChanged) return;
        _isChanged = value;
        OnPropertyChanged();
    }
}

```

Open `MainWindows.xaml`, and add an additional `RowDefinition` to the `Grid` that contains the details `TextBoxes`. The start of the `Grid` is shown here:

```

<Grid Grid.Row="1" DataContext="{Binding ElementName=cboCars, Path=SelectedItem}">
    <Grid.ColumnDefinitions>
        <ColumnDefinition Width="Auto" SharedSizeGroup="CarLabels"/>
        <ColumnDefinition Width="*/>
    </Grid.ColumnDefinitions>
    <Grid.RowDefinitions>
        <RowDefinition Height="Auto"/>
        <RowDefinition Height="Auto"/>
        <RowDefinition Height="Auto"/>
        <RowDefinition Height="Auto"/>
        <RowDefinition Height="Auto"/>
    </Grid.RowDefinitions>

```

At the end of that `Grid`, add a `Label` and a `CheckBox`, and then bind the `CheckBox` to the `IsChanged` property as follows:

```

<Label Grid.Column="0" Grid.Row="4" Content="Is Changed"/>
<CheckBox Grid.Column="1" Grid.Row="4" VerticalAlignment="Center"
    Margin="10,0,0,0" IsEnabled="False" IsChecked="{Binding Path=IsChanged}" />

```

You need to set the `IsChanged` property to `true` anytime another property changes. The best place to do this is in the `OnPropertyChanged` helper method, since it is called any time a property changes. You also need to make sure that you aren't setting `IsChanged` to `true` when `IsChanged` is changed, or you will hit a stack overflow exception! Open `Inventory.cs` and update the `OnPropertyChanged` method to the following (which uses the `nameof` method discussed earlier):

```
protected virtual void OnPropertyChanged([CallerMemberName] string propertyName = "")
{
    if (propertyName != nameof(IsChanged))
    {
        IsChanged = true;
    }
    PropertyChanged?.Invoke(this, new PropertyChangedEventArgs(propertyName));
}
```

If you were run the app now, you would see that every single record shows up as changed, even though you haven't changed anything! This is because object creation sets property values, and setting any values calls `OnPropertyChanged`. This sets the object's `IsChanged` property. To correct this, set the `IsChanged` property to `false` as the last property in the object initialization code. Open `MainWindow.xaml.cs` and change code to create the list to the following:

```
_cars = new ObservableCollection<Inventory>
{
    //IsChanged must be last in the list
    new Inventory {CarId=1,Color="Blue",Make="Chevy",PetName="Kit", IsChanged = false},
    new Inventory {CarId=2,Color="Red",Make="Ford",PetName="Red Rider", IsChanged = false },
};
```

Run the app again, select a vehicle, and click the `Change Color` button. You will see the check box get checked along with the new color, as shown in [Figure 30-4](#).

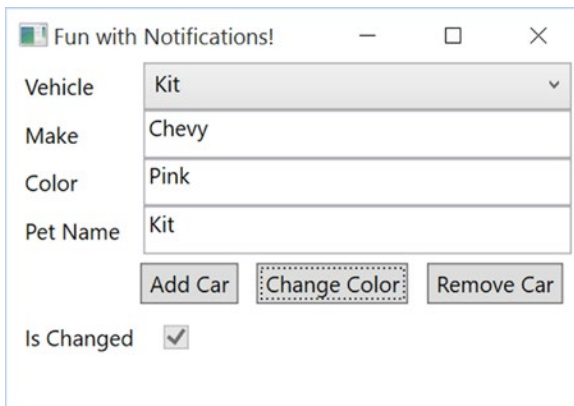

Figure 30-4. Showing the `IsDirty` flag

Updating the Source Through UI Interaction

You might notice that if you type text into the UI, the Is Changed check box doesn't actually get checked until you tab out of the control being edited. This is due to the `UpdateSourceTrigger` property on the `TextBox` bindings. The `UpdateSourceTrigger` determines what event (such as changing the value, tabbing out, etc.) causes the UI to update the underlying data. There are four options, as shown in Table 30-3.

Table 30-3. *UpdateSourceTrigger Values*

| Member | Meaning in Life |
|------------------------------|---|
| Default | Set to the default for the control (e.g. <code>LostFocus</code> for <code>TextBoxes</code>). |
| Explicit | Updates source object only when the <code>UpdateSource</code> method is called. |
| <code>LostFocus</code> | Updates when the control loses focus. Default for <code>TextBoxes</code> . |
| <code>PropertyChanged</code> | Updates as soon as the property changes. Default for <code>CheckBoxes</code> . |

The default for `TextBoxes` is `LostFocus`. Change this to `PropertyChanged` by updating the binding for the `Color TextBox` to the following XAML:

```
<TextBox Grid.Column="1" Grid.Row="1"
  Text="{Binding Path=Color, UpdateSourceTrigger=PropertyChanged}" />
```

Now, when you run the app and start typing into the `Color` text box, the `Is Changed` check box is immediately checked. You might ask why the default is set to `LostFocus` for `TextBoxes`. Any validation (covered in the next section) for a model fires every time the `PropertyChanged` event is raised. For a `TextBox`, this would then potentially cause errors continually flashing until the user entered in the correct values. For example, if the validation rules don't allow less than five characters in a `TextBox`, the error would show on each keystroke until the user got five or more entered. In those cases, it's best to wait for the user to tab out of the `TextBox` (after completing the change to the text) to fire the `PropertyChanged` event.

The Final Word

Using `INotifyPropertyChanged` and `INotifyCollectionChanged` improves your app's user experience by keeping the data and the UI in sync. While neither interface is complicated, they do require updates to your code. Fortunately, Microsoft has included the `ObservableCollection` class to handle all of the plumbing to create observable collections. Unfortunately, you have to provide all of the plumbing yourself for observable models. While it's not a difficult task, it means you need to touch every setter in your model. This can be problematic if you are creating your models from an existing database, using an ORM (like `Entity Framework`), because your models will be overwritten when you regenerate your model classes. Fortunately, there is a solution to this via an open source library, which you will use later in this chapter.

■ **Source Code** The Notifications project can be found in the Chapter 30 subdirectory.

Validation

Now that you've implemented `INotifyPropertyChanged` and are using an `ObservableCollection`, it's time to add validations to your application. Applications need to validate user input and provide feedback to the user when the data entered is incorrect. This section covers the most common validation mechanisms for modern WPF applications, but these are still just a portion of the capabilities built into WPF.

■ **Note** For a full explanation of all of the validations methods in WPF, please see Matthew McDonald's *Pro WPF in C# 4.5*, available from Apress at www.apress.com/9781430243656.

Validation occurs when a data binding attempts to update the data source. In addition to built-in validations, such as exceptions in a properties setter, you can create custom validation rules. If *any* validation rule (built-in or custom) fails, the `Validation` class, discussed later, comes into play.

Updating the Sample for the Validation Examples

For the validation examples, you can continue working in the same project. Update the `MainWindow.xaml` to add an additional row to contain a `Label` and `TextBox` for the `CarId` property. The best way to do this is to open the designer for the window, and use the mouse to add another row. Make sure to select the bottom `Grid` in the `Document Outline`, and hover the mouse close to the left side of the it. Click the mouse as close to the top with the yellow line showing (Figure 30-5).

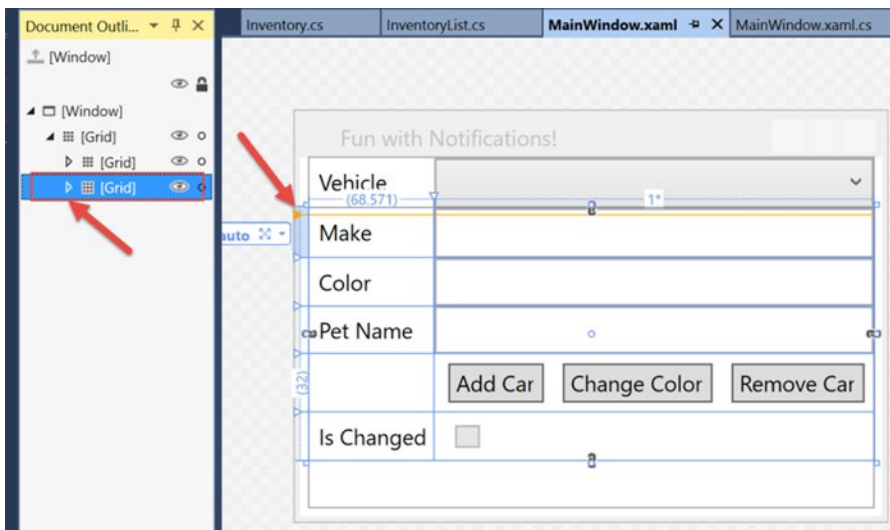

Figure 30-5. Adding a new `Grid` row with the designer

This will create a new row in the Grid and will increase the row number of each element in higher rows by one. You will have to clean up the markup and remove the margins and other values inserted by the designer, but this is the easiest way to add a new row early in the Grid. In the new row, add a Label with the content set to "Id" and a TextBox bound to the CarId property. The markup for the new controls is shown here:

```
<Label Grid.Column="0" Grid.Row="0" Content="Id"/>
<TextBox Grid.Column="1" Grid.Row="0" Text="{Binding Path=CarId}" />
```

When you run the app and select a record, the Id text box is automatically populated with the primary key value (as expected). The updated window should look like Figure 30-6.

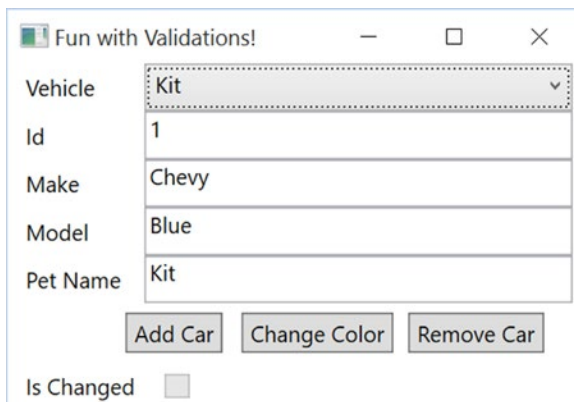

Figure 30-6. Updated to show CardId

Now that you have updated the core application, it's time to explore validations in WPF.

The Validation Class

Before adding validations to your project, it's important to understand the Validation class. This class is part of the validation framework, and it provides methods and attached properties that can be used to display validation results. There are three main properties of the Validation class commonly used when handling validation errors (shown in Table 30-4). You will use each of these through the rest of this section of the chapter.

Table 30-4. Key Members of the Validation Class

| Member | Meaning in Life |
|---------------|---|
| HasError | Attached property indicating that a validation rule failed somewhere in the process |
| Errors | Collection of all active ValidationError objects |
| ErrorTemplate | Control template that becomes visible and adorns the bound element when HasError is set to true |

Validation Options

As mentioned, XAML technologies have several mechanisms for incorporating validation logic into your application. You will examine three of the most commonly used validation choices in the next sections.

Notify on Exceptions

While exceptions should not be used to enforce business logic, exceptions can and do happen, and they should be handled appropriately. In case they aren't handled in code, the user should receive visual feedback of the problem. One change in WPF from WinForms is that binding exceptions are (by default) not displayed to the user, but instead "swallowed." You, as the developer, must opt in to show errors.

To test this, run the app, select a record from the ComboBox, and clear out the Id value. Recall from the definition of the CarId property that you added earlier, that it is defined as an `int` (not a nullable `int`), so a numeric value is required. When you tab out of the Id field, an empty string is sent to the CarId property by the binding framework, and since an empty string can't be converted to an `int`, an exception is thrown in the setter. However, there isn't any indication to the user since you haven't yet opted in to displaying exceptions.

Doing so is easy; all you need to do is add `ValidatesOnExceptions = true` to the binding statements. Update the binding statements in `MainWindow.xaml` to include `ValidatesOnExceptions = true`, as shown here:

```
<TextBox Grid.Column="1" Grid.Row="0"
  Text="{Binding Path=CarId, ValidatesOnExceptions=True}" />
<TextBox Grid.Column="1" Grid.Row="1"
  Text="{Binding Path=Make, ValidatesOnExceptions=True}" />
<TextBox Grid.Column="1" Grid.Row="2"
  Text="{Binding Path=Color, ValidatesOnExceptions=True}" />
<TextBox Grid.Column="1" Grid.Row="3"
  Text="{Binding Path=PetName, ValidatesOnExceptions=True}" />
```

Run the app again, select a vehicle, and once more clear out the Id text box. When you tab out from the Id text box, a red box surrounds it. Since you've updated the binding statements to validate on exceptions, the error is shown by a red box adorning the Id text box (shown in Figure 30-7).

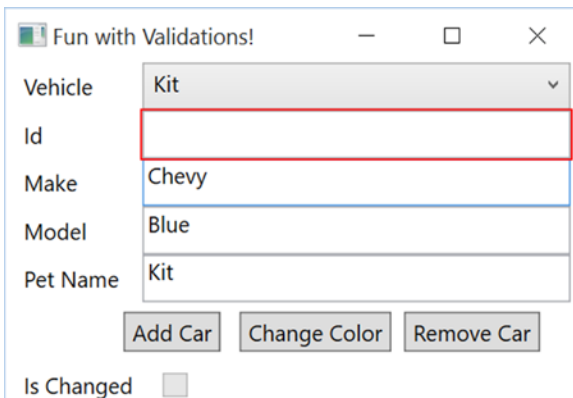

Figure 30-7. The default error template

The red box is the `ErrorTemplate` property of the `Validation` object and acts as an adorning for the bound control. While the default look and feel shows that there is indeed an error, there isn't any indication as to *what* is wrong. The good news is that the `ErrorTemplate` is completely customizable, as you will see later in this chapter.

IDataErrorInfo

The `IDataErrorInfo` interface provides a mechanism for you to add validation to your model classes. Since you add the interface directly to your model classes and the validation code is placed inside your model classes (or in partial classes), this helps to reduce repeating validation code in your project. In WinForms, for example, validation was typically done in the UI itself, which meant every form that used the `Inventory` class (in this example) would have to add the same validation code. If the rules changed, each of these forms would have to be updated. The fact that the implementation can be in a separate file as a partial class prevents your code from being overwritten when reverse engineering your models from an existing database (as shown in Chapter 23).

The `IDataErrorInfo` interface, shown below, contains two properties, an indexer and a string property named `Error`. Note that the WPF binding engine doesn't use the `Error` property.

```
public interface IDataErrorInfo
{
    string this[string columnName] { get; }
    string Error { get; }
}
```

You will be adding the `Inventory` partial class shortly, but first you need to update the `Inventory.cs` class and mark it as partial. Next, add another class to the `Models` directory named `InventoryPartial.cs`. Rename this class `Inventory`, make sure the class is marked as `partial`, and add the `IDataErrorInfo` interface. Finally, implement the API for the interface. The initial code is listed here:

```
public partial class Inventory : IDataErrorInfo
{
    public string this[string columnName]
    {
        get { return string.Empty; }
    }

    public string Error { get; }
}
```

The indexer gets called each time the `PropertyChanged` event is raised on the object. The property name from the event is used as the `columnName` parameter in the indexer. If the indexer returns `string.Empty`, the framework assumes that all validations passed, and no error condition exists. If the indexer returns anything but `string.Empty`, an error is presumed to exist on the property for that object instance, and each control that is bound to this property (and this specific instance of the class) is considered to have an error. One caveat is that the control will only enlist the `Validation` class if `ValidatesOnDataErrors` is set to `true` in the binding statement. If it isn't (just like exceptions in the setter in the previous example), the validation error is swallowed, and the user is not notified. If `ValidatesOnDataErrors` is set to `true`, the `HasError` property of the `Validation` object is set to `true`, and the `ErrorTemplate` adorning is activated.

Next, you will add some simple validation logic to the indexer in `InventoryPartial.cs`. The validation rules are simple:

- If `Make` equals `ModelT`, set the error equal to “Too Old”.
- If `Make` equals `Chevy` and `Color` equals `Pink`, set the error equal to `($"{Make}'s don't come in {Color}"`.

Start by adding a switch statement for each of the properties. To avoid using magic strings in the case statements, you will again use the `nameof` method. If the code falls through the switch statement, return `string.Empty`. The code is shown here:

```
public string this[string columnName]
{
    get
    {
        switch (columnName)
        {
            case nameof(CarId):
                break;
            case nameof(Make):
                break;
            case nameof(Color):
                break;
            case nameof(PetName):
                break;
        }
        return string.Empty;
    }
}
```

Next, add in the validation rules. In the proper case statements, add a check of the property value based on the rules listed above. In the case statement for the `Make` property, first check to make sure the value isn't `ModelT`. If it is, return the error. If that passes, the next line will call into a helper method that returns an error if the second rule is violated, or return `string.Empty` if it is not. In the case statement for the `Color` property, also call the helper method. The code is as follows:

```
public string this[string columnName]
{
    get
    {
        switch (columnName)
        {
            case nameof(CarId):
                break;
            case nameof(Make):
                if (Make == "ModelT")
                {
                    return "Too Old";
                }
                return CheckMakeAndColor();
            case nameof(Color):
                return CheckMakeAndColor();
        }
    }
}
```

```

        case nameof(PetName):
            break;
    }
    return string.Empty;
}

internal string CheckMakeAndColor()
{
    if (Make == "Chevy" && Color == "Pink")
    {
        return $"{Make}'s don't come in {Color}";
        //AddError(nameof(Color), $"{Make}'s don't come in {Color}");
        //hasError = true;
    }
    return string.Empty;
}

```

As the final step, update the Binding statements to include `ValidatesOnDataErrors = true`, as in the following code:

```

<TextBox Grid.Column="1" Grid.Row="0"
    Text="{Binding Path=CarId, ValidatesOnExceptions=True, ValidatesOnDataErrors=True}" />
<TextBox Grid.Column="1" Grid.Row="1"
    Text="{Binding Path=Make, ValidatesOnExceptions=True, ValidatesOnDataErrors=True}" />
<TextBox Grid.Column="1" Grid.Row="2"
    Text="{Binding Path=Color, ValidatesOnExceptions=True, ValidatesOnDataErrors=True}" />
<TextBox Grid.Column="1" Grid.Row="3"
    Text="{Binding Path=PetName, ValidatesOnExceptions=True, ValidatesOnDataErrors=True}" />

```

Run the app, select the Red Rider vehicle (the Ford), and change the Make to ModelT. Once you tab out of the field, the red error decorator appears. Now select Kit (which is a Chevy) from the drop-down, and click the Change Color button to change the color to Pink. Immediately the red error adorning appears on the Color field, but doesn't appear on the Make text box. Now, change the Make to Ford, tab out of the text box, and note that the red adorning does *not* disappear!

This is because the indexer only runs when the `PropertyChanged` event is fired for a property. As discussed in the “Notifications” section, the `PropertyChanged` event fires when the source object's property changes, and this happens either through code (such as clicking the Change Color button) or through user interaction (the timing of this is controlled through the `UpdateSourceTrigger`). When you changed the color, the Make property did not change, so the event did not fire for the Make property. Since the event didn't fire, the indexer did not get called, so the validation for the Make property didn't run.

There are two ways to fix this. The first is to change the `PropertyChangedEventArgs` to update every bound property by passing in `string.Empty` instead of a field name. As discussed, this causes the binding engine to update *every* property on that instance. Update the `OnPropertyChanged` method to this:

```

protected virtual void OnPropertyChanged([CallerMemberName] string propertyName = "")
{
    if (propertyName != nameof(IsChanged))
    {
        IsChanged = true;
    }
}

```

```

//PropertyChanged?.Invoke(this, new PropertyChangedEventArgs(propertyName));
PropertyChanged?.Invoke(this, new PropertyChangedEventArgs(string.Empty));
}

```

Now, when you run the same test, you see that both the Make and the Color text boxes are adorned with the error template when one of them is updated. So why not always raise the event in this manner? It's largely a matter of performance. It's *possible* that refreshing every property on an object could hamper performance. Of course, there's no way to know without testing, and your mileage may (and probably will) vary.

The other solution is to raise the `PropertyChanged` event for the other dependent field(s) when one changes. The downside to using this mechanism is that you (or other developers that support your app) must know that in the `InventoryPartial.cs` class, the Make and Color properties are related through the validation code. To implement the change, add the following calls to the `OnPropertyChanged` method in the setters for Make and Color:

```

private string _make;
public string Make
{
    get { return _make; }
    set
    {
        if (value == _make) return;
        _make = value;
        OnPropertyChanged(nameof(Make));
        OnPropertyChanged(nameof(Color));
    }
}

private string _color;
public string Color
{
    get { return _color; }
    set
    {
        if (value == _color) return;
        _color = value;
        OnPropertyChanged(nameof(Color));
        OnPropertyChanged(nameof(Make));
    }
}

```

Run the app again, select a Chevy, and click the Change Color button. Now, both Make and Color get the error adorning. Change the make to something other than a Chevy, and when you tab out of the Make text box, the adorning is removed for both text boxes.

INotifyDataErrorInfo

The `INotifyDataErrorInfo` interface introduced in .NET 4.5, builds on the `IDataErrorInfo` interface, and adds additional capabilities for validation. Of course, with additional power comes additional work! In a drastic shift from prior validation techniques that you had to specifically opt into, the `ValidatesOnNotifyDataErrors` binding property defaults to `true`, so adding the property to your binding statements is optional.

The `INotifyDataErrorInfo` interface is extremely small, but does take a significant amount of plumbing code, as you will see shortly. The interface is shown here:

```
public interface INotifyDataErrorInfo
{
    bool HasErrors { get; }
    event EventHandler<DataErrorsChangedEventArgs> ErrorsChanged;
    IEnumerable GetErrors(string propertyName);
}
```

The `HasErrors` property is used by the binding engine to determine if there are *any* errors on any of the instance's properties that are binding sources. If the `GetErrors` method is called with a null or empty string for the `propertyName` parameter, it returns all errors that exist in the instance. If a `propertyName` is passed into the method, only the errors for that particular property are returned. The `ErrorsChanged` event (like the `PropertyChanged` and `CollectionChanged` events) notifies the binding engine to update the UI.

Implementing the Supporting Code

To implement this, it takes a fair amount of plumbing code. The good news is that all of this code can be pushed down into a base model class, and needs only be written once. Start by replacing `IDataErrorInfo` with `INotifyDataErrorInfo` to the `InventoryPartial.cs` class (you can leave the code from `IDataErrorInfo` in the class; it won't get in the way).

After adding the interface members, add a private variable that will hold any errors. The current status of the code is shown here:

```
private readonly Dictionary<string,List<string>> _errors = new Dictionary<string,
List<string>>();
public IEnumerable GetErrors(string propertyName)
{
    throw new NotImplementedException();
}

public bool HasErrors
{
    get
    {
        throw new NotImplementedException();
    }
}
public event EventHandler<DataErrorsChangedEventArgs> ErrorsChanged;
```

The `HasErrors` property should return `true` if there are *any* errors in the dictionary. This is easily accomplished like this:

```
public bool HasErrors => _errors.Count != 0;
```

Next, create a helper method to raise the `ErrorsChanged` event (just like raising the `PropertyChanged` event) like this:

```
private void OnErrorsChanged(string propertyName)
{
    ErrorsChanged?.Invoke(this, new DataErrorsChangedEventArgs(propertyName));
}
```

The `GetErrors` method should return any and all errors in the dictionary if the parameter is empty or null. If a valid `propertyName` is passed in, it will return any errors found for that property. If the parameter doesn't match (or there aren't any errors for a property), then the method will return null.

```
public IEnumerable GetErrors(string propertyName)
{
    if (string.IsNullOrEmpty(propertyName))
    {
        return _errors.Values;
    }
    return _errors.ContainsKey(propertyName) ? _errors[propertyName] : null;
}
```

The final set of helpers will add one or more errors for a property or clear all of the errors for a property. Any time the dictionary changes, remember to call the `OnErrorsChanged` helper method:

```
protected void ClearErrors(string propertyName = "")
{
    _errors.Remove(propertyName);
    OnErrorsChanged(propertyName);
}

private void AddError(string propertyName, string error)
{
    AddErrors(propertyName, new List<string> {error});
}

private void AddErrors(string propertyName, IList<string> errors)
{
    var changed = false;
    if (!_errors.ContainsKey(propertyName))
    {
        _errors.Add(propertyName, new List<string>());
        changed = true;
    }
    errors.ToList().ForEach(x =>
    {
        if (_errors[propertyName].Contains(x)) return;
        _errors[propertyName].Add(x);
        changed = true;
    });
}
```

```

    if (changed)
    {
        OnErrorsChanged(propertyName);
    }
}

```

The binding engine listens for the `ErrorsChanged` event, and will update the UI if there is a change in the errors collection for a binding statement. This removes the need to call `PropertyChanged` or `CollectionChanged` just to update the UI with error conditions, as you did when implementing `IDataErrorInfo`. This means that the extra calls to raise `PropertyChanged` in the `Make` and `Color` setters (to make sure the errors are displayed when the other property changes) are no longer needed. Of course, you still need to raise `PropertyChanged` and `CollectionChanged` for the UI to respond to *data* changes, just not *error* changes. Remove the additional calls to `OnPropertyChanged` in the setters for `Make` and `Color`, like this:

```

private string _make;
public string Make
{
    get { return _make; }
    set
    {
        if (value == _make) return;
        _make = value;
        OnPropertyChanged(nameof(Make));
    }
}

private string _color;
public string Color
{
    get { return _color; }
    set
    {
        if (value == _color) return;
        _color = value;
        OnPropertyChanged(nameof(Color));
    }
}

```

Using `INotifyDataErrorInfo` for Validations

Now that you have all of the support code in place, it's time to add the validations back into your app using `INotifyDataErrorInfo`. Even though you have implemented the code to support `INotifyDataErrorInfo`, you still have to determine where and when to check for errors and add the errors to the errors list. One place to check for errors is in the property setters, like the following example, simplified to just check for the `ModelT` validation:

```

public string Make
{
    get { return _make; }
    set

```

```

{
    if (value == _make) return;
    _make = value;
    if (Make == "ModelT")
    {
        AddError(nameof(Make), "Too Old");
    }
    else
    {
        ClearErrors(nameof(Make));
    }
    OnPropertyChanged(nameof(Make));
    //OnPropertyChanged(nameof(Color));
}
}

```

One of the issues with this approach is that the class will be overwritten if you update your model from an existing database, causing you to lose all of your validation code. Even if you are using the code-first approach to generate and update your database, you have still muddled together model code with validation code, making your code harder to support.

You saw in the previous section that `IDataErrorInfo` can be added to a partial class, which means you don't have to update your setters. This cleans up your model code, leaving only the call to raise `PropertyChanged` in the setters. Combining `IDataErrorInfo` and `INotifyDataErrorInfo` provides you with the additional features for validations from `INotifyDataErrorInfo`, and the separation from the setters provided by `IDataErrorInfo`.

Add the `IDataErrorInfo` interface back onto the `Inventory` class that is in `InventoryPartial.cs`.

```
public partial class Inventory : IDataErrorInfo, INotifyDataErrorInfo
```

The purpose of using `IDataErrorInfo` is not to run validations, but to make sure your validation code that leverages `INotifyDataErrorInfo` gets called every time `PropertyChanged` is raised on your object. Since you aren't using `IDataErrorInfo` for validation, always return `string.Empty` because the `ErrorsChanged` event is now responsible for notifying the binding engine when there are errors. Update the indexer and the `CheckMakeAndColor` helper method to the following code:

```

public string this[string columnName]
{
    get
    {
        bool hasError = false;
        switch (columnName)
        {
            case nameof(CarId):
                break;
            case nameof(Make):
                hasError = CheckMakeAndColor();
                if (Make == "ModelT")
                {
                    AddError(nameof(Make), "Too Old");
                    hasError = true;
                }
        }
    }
}

```

```

        if (!hasError) ClearErrors(nameof(Make));
        break;
    case nameof(Color):
        hasError = CheckMakeAndColor();
        if (!hasError) ClearErrors(nameof(Color));
        break;
    case nameof(PetName):
        break;
    }
    return string.Empty;
}
}
internal bool CheckMakeAndColor()
{
    if (Make == "Chevy" && Color == "Pink")
    {
        //return $"{Make}'s don't come in {Color}";
        AddError(nameof(Make), $"{Make}'s don't come in {Color}");
        AddError(nameof(Color), $"{Make}'s don't come in {Color}");
        return true;
    }
    return false;
}
}

```

Run the app, select the Chevy, and change the color to Pink. In addition to the red adorners around the Make and Model text boxes, you will also see a red box adorer around the entire grid that holds the Inventory details fields (shown in Figure 30-8). This is another advantage of using `INotifyDataErrorInfo`. As a reminder, the data context is set to the selected item in the ComboBox. This sets the data source for the Grid and all of its child controls. When `PropertyChanged` is raised, the data context calls the `GetErrors` method to check if there are *any* errors on the object instance, and if so, activates the `Validation` class.

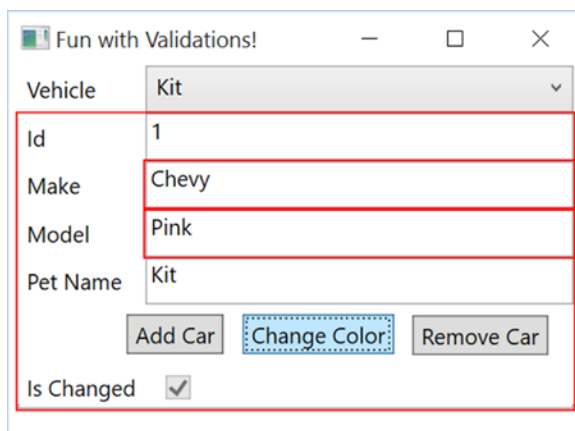

Figure 30-8. The updated error adorer

Showing All Errors

The `Errors` property on the `Validation` class returns all of the validation errors on a particular object. The property returns a list of `ValidationError` objects, and each `ValidationError` object has an `ErrorContent` property that contains the list of error messages for each property. Since the actual error messages you want to display are in this list within a list, you need to create a `DataTemplate` on a `ListBox` that holds a `ListBox`. It sounds a bit recursive, but it makes sense once you see it.

Start by adding another row to the `Grid` and increase the `Height` of the `Window` to 300. Add a `ListBox` in the last row, and bind the `ItemsSource` of the `ListBox` to the `Grid`, using `Validation.Errors` for the path, as follows:

```
<ListBox Grid.Row="6" Grid.Column="0" Grid.ColumnSpan="2"
  ItemsSource="{Binding ElementName=testGrid, Path=(Validation.Errors)}">
</ListBox>
```

Add a `DataTemplate`, and in the `DataTemplate`, add a `ListBox` that is bound to the `ErrorContent` property. The data context for each `ListBoxItem` in this case is a `ValidationError` object, so you don't need to set the data context, just the path. Set the binding path to `ErrorContent`, like this:

```
<ListBox.ItemTemplate>
  <DataTemplate>
    <ListBox ItemsSource="{Binding Path=ErrorContent}"/>
  </DataTemplate>
</ListBox.ItemTemplate>
```

The final markup is shown here:

```
<ListBox Grid.Row="6" Grid.Column="0" Grid.ColumnSpan="2"
  ItemsSource="{Binding ElementName=testGrid, Path=(Validation.Errors)}">
  <ListBox.ItemTemplate>
    <DataTemplate>
      <ListBox ItemsSource="{Binding Path=ErrorContent}"/>
    </DataTemplate>
  </ListBox.ItemTemplate>
</ListBox>
```

Run the app, select the Chevy, and set the color to Pink. You will see the errors displayed in [Figure 30-9](#).

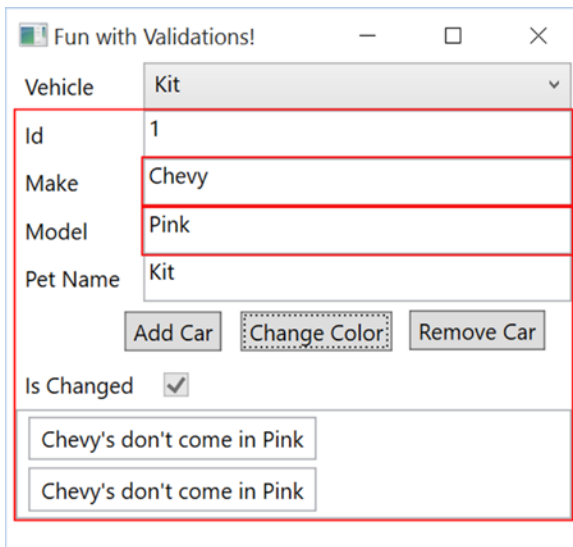

Figure 30-9. Showing the errors collection

Move the Support Code to a Base Class

As you probably noticed, there is a lot of code now in the `InventoryPartial.cs` class. Since this example only has one model class, this isn't terrible. But, as you add models to a real application, you don't want to have to add in all of that plumbing into each partial class for your models. The best thing to do is to push all of that supporting code down to a base class. You will do that now.

Add a new class file to the `Models` folder named `EntityBase.cs`. Add usings for `System.Collections` and `System.ComponentModel`. Make the class public, and add the `INotifyDataErrorInfo` interface, like this:

```
using System;
using System.Collections;
using System.Collections.Generic;
using System.ComponentModel;
using System.Linq;

namespace Validations.Models
{
    public class EntityBase : INotifyDataErrorInfo
    {
    }
}
```

Move all of the code from `InventoryPartial.cs` that relates to `INotifyDataErrorInfo` into the new class. Any private methods need to be made protected. The updated code is shown here:

```
public class EntityBase : INotifyDataErrorInfo
{
    //INotifyDataErrorInfo
    protected readonly Dictionary<string, List<string>> _errors = new Dictionary<string,
    List<string>>();
}
```

```

protected void ClearErrors(string propertyName = "")
{
    _errors.Remove(propertyName);
    OnErrorsChanged(propertyName);
}

protected void AddError(string propertyName, string error)
{
    AddErrors(propertyName, new List<string> { error });
}

protected void AddErrors(string propertyName, IList<string> errors)
{
    var changed = false;
    if (!_errors.ContainsKey(propertyName))
    {
        _errors.Add(propertyName, new List<string>());
        changed = true;
    }
    errors.ToList().ForEach(x =>
    {
        if (_errors[propertyName].Contains(x)) return;
        _errors[propertyName].Add(x);
        changed = true;
    });
    if (changed)
    {
        OnErrorsChanged(propertyName);
    }
}

public IEnumerable GetErrors(string propertyName)
{
    if (string.IsNullOrEmpty(propertyName))
    {
        return _errors.Values;
    }
    return _errors.ContainsKey(propertyName) ? _errors[propertyName] : null;
}

public bool HasErrors => _errors.Count != 0;
public event EventHandler<DataErrorsChangedEventArgs> ErrorsChanged;

protected void OnErrorsChanged(string propertyName)
{
    ErrorsChanged?.Invoke(this, new DataErrorsChangedEventArgs(propertyName));
}
}

```

Next, remove the `INotifyDataErrorInfo` interface from the `InventoryPartial.cs` class, and add `EntityBase` as a base class, as follows:

```
public partial class Inventory : EntityBase, IDataErrorInfo
{
    //removed for brevity
}
```

Now, any additional model classes you create will inherit all of the `INotifyDataErrorInfo` plumbing code. There is more that you can push down into the base class, most notably the `INotifyPropertyChanged` code, but you will do that later in this chapter.

Using Data Annotations

As you learned in Chapter 23, EF makes heavy use of Data Annotations. WPF can leverage these as well for UI validation. Let's add some Data Annotations to the `Inventory` model.

Adding Data Annotations

Add a project reference to `System.ComponentModel.DataAnnotations`, and then open up `Inventory.cs` and add a `using` for `System.ComponentModel.DataAnnotations`. Add the `[Required]` attribute to the `CarId`, `Make`, and `Color` properties, and `[StringLength(50)]` to `Make`, `Color`, and `PetName`. The `Required` attribute adds a validation rule that the property must not be null (admittedly, this is redundant for the `CarId` property since it is not a nullable `int`). The `StringLength` attribute adds a validation rule that the property cannot be longer than 30 characters. An abbreviated view of the code is shown here:

```
[Required]
public int CarId

[Required, StringLength(50)]
public string Make

[Required, StringLength(50)]
public string Color

[StringLength(50)]
public string PetName
```

Checking for Data Annotation-Based Validation Errors

Now that the additional validation rules have been added, they need to be added into the validation process. Unlike ASP.NET MVC and ASP.NET Web Forms (both of which can automatically check the model for validation errors based on Data Annotations), in WPF you have to programmatically check for Data Annotation-based validation errors.

Before you add the code to check for validation errors, there are a couple of objects that need to be discussed. The first is the `ValidationContext`. This provides a context for checking a class for validation errors using the `Validator` class. The `Validator` class allows you to check an object for attribute-based errors within a `ValidationContext`.

Open `EntityBase.cs`, and add a `using` for `System.ComponentModel.DataAnnotations`. Next, create a new method named `GetErrorsFromAnnotations`. This method is generic, takes a string property name, and a value of type `T` as the parameters, and returns a string array. Make sure the method is marked as `protected`. The signature is listed here:

```
protected string[] GetErrorsFromAnnotations<T>(string propertyName, T value)
```

In the method, create a `List<ValidationResult>` variable that will hold the results of validation checks. Next, create a `ValidationContext` scoped to the property name passed into the method. When you have those two items in place, call `Validator.TryValidateProperty`, which returns a `bool`. If everything passes (in regards to Data Annotations validations), it returns `true`. If not, it returns `false`, and populates the `List<ValidationResult>` with the errors. The complete code is shown here:

```
protected string[] GetErrorsFromAnnotations<T>(string propertyName, T value)
{
    var results = new List<ValidationResult>();
    var vc = new ValidationContext(this, null, null) { MemberName = propertyName };
    var isValid = Validator.TryValidateProperty(value, vc, results);
    return (isValid)?null:Array.ConvertAll(results.ToArray(), o => o.ErrorMessage);
}
```

Now you can update the indexer method to check for any errors based on Data Annotations. If any errors are found, add them to the errors collection supporting `INotifyDataErrorInfo`. The updated indexer code is shown here:

```
public string this[string columnName]
{
    get
    {
        string[] errors = null;
        bool hasError = false;
        switch (columnName)
        {
            case nameof(CarId):
                errors = GetErrorsFromAnnotations(nameof(CarId), CarId);
                break;
            case nameof(Make):
                hasError = CheckMakeAndColor();
                if (Make == "ModelT")
                {
                    AddError(nameof(Make), "Too Old");
                    hasError = true;
                }
                errors = GetErrorsFromAnnotations(nameof(Make), Make);
                break;
            case nameof(Color):
                hasError = CheckMakeAndColor();
                errors = GetErrorsFromAnnotations(nameof(Color), Color);
                break;
            case nameof(PetName):
                errors = GetErrorsFromAnnotations(nameof(PetName), PetName);
                break;
        }
    }
}
```

```

if (errors != null && errors.Length != 0)
{
    AddErrors(columnName, errors);
    hasError = true;
}
if (!hasError) ClearErrors(columnName);
return string.Empty;
}
}

```

Run the app, select one of the vehicles, and add text for the model that is longer than 50 characters. When you tab out, the `StringLength` Data Annotation reports a validation error via the `GetErrorsFromAnnotations` method. These errors are reported by `INotifyDataErrorInfo`, and cause the error template adorning to appear, as well as the `ListBox` to show the message (shown in Figure 30-10).

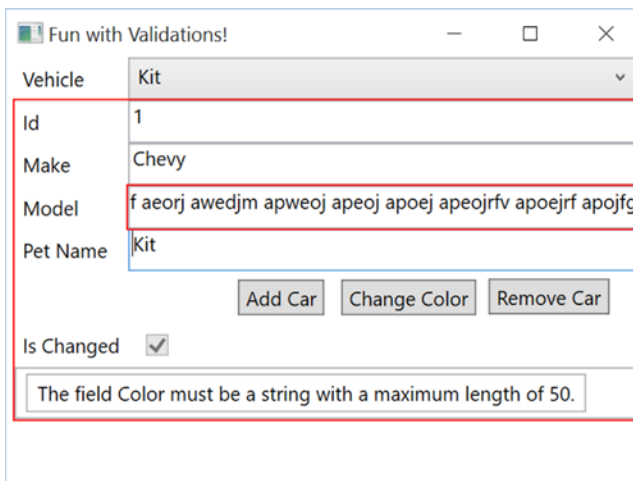

Figure 30-10. Validating the required Data Annotation

Customizing the ErrorTemplate

The final topic is to update the `ErrorTemplate` in order for the controls to display more meaningful information regarding errors with the data. As you learned in Chapter 29, controls are customizable through their control templates. As you learned earlier in this chapter, the `Validation` class has an `ErrorTemplate` that is used to adorn a control that has a binding error.

Start by adding a new style in the Windows Resources section of `MainWindow.xaml` with a target type of `TextBox`, as follows:

```

<Window.Resources>
    <Style TargetType="{x:Type TextBox}">
    </Style>
</Window.Resources>

```

Next, add a trigger on the style that sets properties when `Validation.HasError` is set to true. The properties and the values to set are `Background` (Pink), `Foreground` (Black), and `ToolTip` to the `ErrorContent`. The `Background` and `Foreground` setters are nothing new, but the `ToolTip` needs some explanation. The binding points back to the `TextBox` that this style is executed on as the data source. The path is the first `ErrorContent` value of the `Validation.Errors` collection. The markup is as follows:

```
<Style TargetType="{x:Type TextBox}">
  <Style.Triggers>
    <Trigger Property="Validation.HasError" Value="true">
      <Setter Property="Background" Value="Pink" />
      <Setter Property="Foreground" Value="Black" />
      <Setter Property="ToolTip"
        Value="{Binding RelativeSource={RelativeSource Self},
          Path=(Validation.Errors)[0].ErrorContent}"/>
    </Trigger>
  </Style.Triggers>
</Style>
```

Next, you will update the `ErrorTemplate` of the `Validation` class to show a red exclamation mark, and set the `ToolTips` for the exclamation mark. Place a setter immediately after the `Style.Triggers` closing tag within the style you just created. You will be creating a control template that consists of a `TextBlock` (to show the exclamation mark) and a `BorderBrush` to surround the `TextBox` that contains the error(s). There is a special tag in XAML for the control that is being adorned with the `ErrorTemplate` named `AdornedElementPlaceholder`. By adding a name to this control, you can access the errors that are associated with the control. In this example, you want to access the `Validation.Errors` property so you can get the `ErrorContent` (just like you did in the `Style.Trigger`). Here is the full markup for the setter:

```
<Setter Property="Validation.ErrorTemplate">
  <Setter.Value>
    <ControlTemplate>
      <DockPanel LastChildFill="True">
        <TextBlock Foreground="Red" FontSize="20" Text="!"
          ToolTip="{Binding ElementName=controlWithError,
            Path=AdornedElement.(Validation.Errors)[0].ErrorContent}"/>
        <Border BorderBrush="Red" BorderThickness="1">
          <AdornedElementPlaceholder Name="controlWithError" />
        </Border>
      </DockPanel>
    </ControlTemplate>
  </Setter.Value>
</Setter>
```

Run the app, and create an error condition. The result will be similar to Figure 30-11.

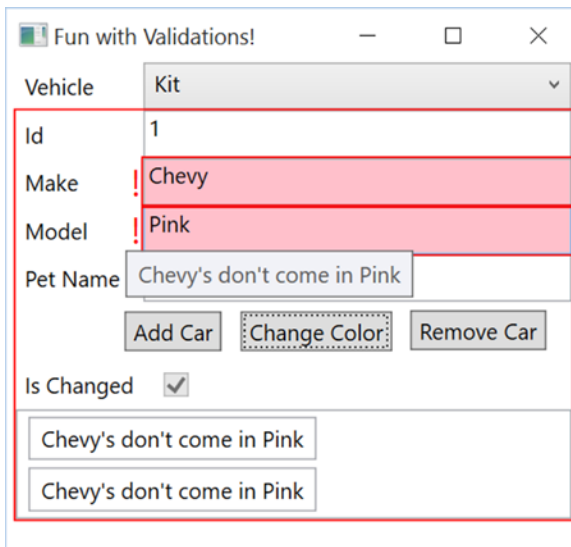

Figure 30-11. Showing a custom *ErrorTemplate*

■ **Source Code** The Validations project can be found in the Chapter 30 subdirectory.

Creating Custom Commands

As you learned in Chapter 27, commands are an integral part of WPF. Commands can be hooked up to WPF controls (such as Buttons and MenuItems) to handle user events, such as the click. Instead of creating an event handler directly, the Execute method of the command is executed when the event fires. The CanExecute method is used to enable or disable the control based on your custom code. In addition to the built-in commands you used in Chapter 27, you can create your own custom commands by implementing the ICommand interface. By using commands instead of event handlers, you gain the benefit of encapsulating application code, as well as automatically enabling and disabling controls based on business logic.

Implementing the ICommand Interface

As a quick review from Chapter 27, the ICommand interface is listed here:

```
public interface ICommand
{
    event EventHandler CanExecuteChanged;
    bool CanExecute(object parameter);
    void Execute(object parameter);
}
```

Now you will create a command that changes the color of an Inventory object. Start by right-clicking the project name in Solution Explorer and creating a new folder named Cms. Add a new class named ChangeColorCommand.cs. Add the ICommand interface to the class, implement the members, and add a using for Validations.Models. Your code should look like this:

```
public class ChangeColorCommand : ICommand
{
    public bool CanExecute(object parameter)
    {
        throw new NotImplementedException();
    }
    public void Execute(object parameter)
    {
        throw new NotImplementedException();
    }
    public event EventHandler CanExecuteChanged;
}
```

The parameter passed into the CanExecute and Execute methods is sent from the UI through the CommandParameter property set on binding statements. You will make this change later in this section. For now, you just need to know that, in this example, the object is expected to be of type Inventory. If the object is null or not an Inventory object, then the CanExecute method must return false, and any controls bound to the command are disabled. If it is not null, and is an Inventory object, then the method must return true, and any controls bound to the command are enabled. Update the CanExecute method to the following:

```
public override bool CanExecute(object parameter) => (parameter as Inventory) != null;
```

The parameter for the Execute method works exactly the same as the parameter for the CanExecute method. The Execute method only fires if the user clicks a control bound to the command, and the user can only click the control if the CanExecute method returns true. The type is of type object, so you still have to cast the parameter to an Inventory object. After casting the parameter, change the color of the car to Pink. Update the Execute method to the following:

```
public override void Execute(object parameter)
{
    ((Inventory)parameter).Color="Pink";
}
```

Updating MainWindow.xaml.cs

The next change is to create an instance of this class that the Button can access. For now, you will place this in the code-behind file for the MainWindow (later in this chapter you will move this into a ViewModel). Open MainWindow.xaml.cs and delete the click event handler for the Change Color button, since you will replace this functionality with your command implementation.

Next, add a public property named ChangeColorCmd of type ICommand with a backing field. In the expression body for the property, return the backing property (make sure to instantiate a new instance of the ChangeColorCommand if the backing field is null).

```
private ICommand _changeColorCommand = null;
public ICommand ChangeColorCmd => _changeColorCommand ?? (_changeColorCommand = new
ChangeColorCommand());
```

Updating MainWindow.xaml

As you saw in Chapter 27, clickable controls in WPF (like Buttons) have a `Command` property that allows you to assign a command object to the control. Once the command object is connected to a control, the `CanExecute` method determines if the control is enabled, and the click event is attached to the `Execute` method.

Start by connecting your command instantiated in the code-behind to the `btnChangeColor` button. Since the property for the command is on the `MainWindow` class, you use the `RelativeSourceMode` binding syntax to get to the Window that contains the Button, as follows:

```
Command="{Binding Path=ChangeColorCmd,
  RelativeSource={RelativeSource Mode=FindAncestor, AncestorType={x:Type Window}}}"
```

The Button still needs to send in an `Inventory` object as the parameter for the `CanExecute` and `Execute` methods. There is another property on the clickable controls named `CommandParameter`. You set this to the `SelectedItem` of the `cboCars` `ComboBox`, as follows:

```
CommandParameter="{Binding ElementName=cboCars, Path=SelectedItem}"
```

The complete markup for the button is shown here:

```
<Button x:Name="btnchangeColor" Content="Change Color" Margin="5,0,5,0" Padding="4,2"
  Command="{Binding Path=ChangeColorCmd,
  RelativeSource={RelativeSource Mode=FindAncestor, AncestorType={x:Type Window}}}"
  CommandParameter="{Binding ElementName=cboCars, Path=SelectedItem}"/>
```

Attaching Command to the CommandManager

If you were to run the app now, you would see that the `Change Color` button is not enabled when the Window first loads. This is what we expected because the `SelectedItem` for the combo box is null. Since this is the value that gets passed into the `CanExecute` and `Execute` methods, the control is disabled. If you select a record from the combo box, you would expect the button to become enabled since the `SelectedItem` property is no longer null. However, you see that the button is still disabled.

This is because the `CanExecute` method fires when the Window first loads and then when the command manager instructs it to fire. Each command class has to opt in to the command manager. This is done with the `CanExecuteChanged` event, and is as simple as adding the following code to your `ChangeColorCommand.cs` class:

```
public event EventHandler CanExecuteChanged
{
  add { CommandManager.RequerySuggested += value; }
  remove { CommandManager.RequerySuggested -= value; }
}
```

Creating the CommandBase Class

This code needs to be in every custom command that you build, so it's best to create an abstract base class to hold it. Create a new class in the Cms folder named `CommandBase`, set the class to abstract, add the `ICommand` interface, and implement the interface. Add a `using` for the `System.Windows.Input` namespace, and change the `Execute` and `CanExecute` methods to abstract. Finally, add in the `CanExecuteChanged` you just wrote. The full implementation is listed here:

```
public abstract class CommandBase : ICommand
{
    public abstract void Execute(object parameter);
    public abstract bool CanExecute(object parameter);

    public event EventHandler CanExecuteChanged
    {
        add { CommandManager.RequerySuggested += value; }
        remove { CommandManager.RequerySuggested -= value; }
    }
}
```

Updating the ChangeColorCommand Class

Open `ChangeColorCommand.cs`, and add `CommandBase` as the base class. Delete the `CanExecuteChanged` code, and add override to the `CanExecute` and `Execute` methods, like this:

```
internal class ChangeColorCommand : CommandBase
{
    public override void Execute(object parameter)
    {
        ((Inventory)parameter).Color="Pink";
    }

    public override bool CanExecute(object parameter) =>
        (parameter as Inventory) != null;
}
```

Testing the Application

Run the application. You will see that the Change Color command is *not* enabled, as shown in Figure 30-12, since there isn't a vehicle selected.

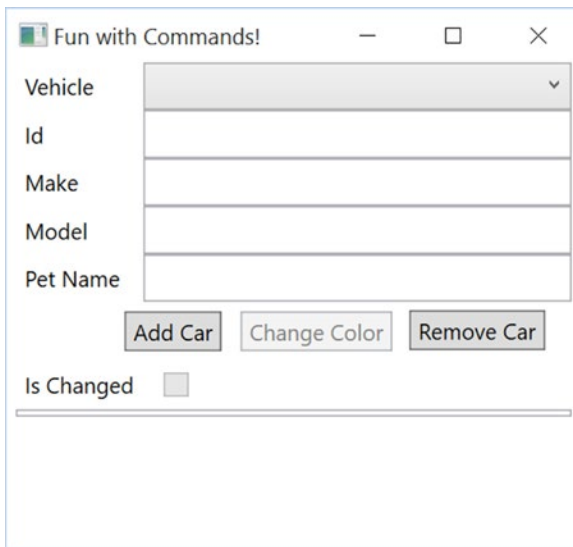

Figure 30-12. A window with nothing selected

Now, select a vehicle, and the button will become *enabled*, as shown in Figure 30-13.

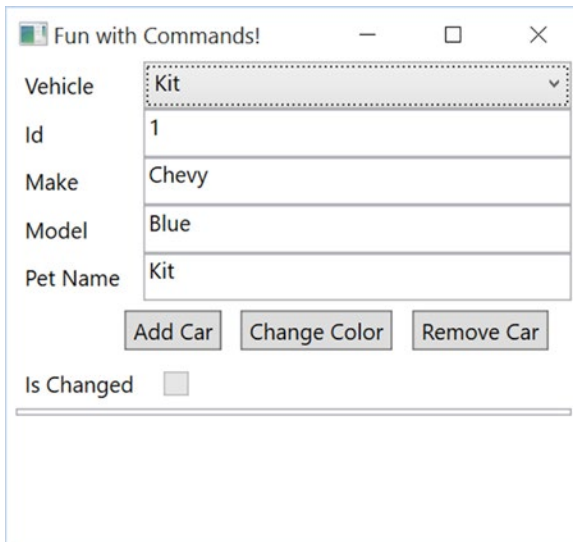

Figure 30-13. A window with a vehicle selected

Adding the Remaining Commands

Now that you understand commands, you are going to replace the remaining two button click events with commands.

Adding the RemoveCarCommand

Just like the ChangeColorCommand, the RemoveCarCommand has a C# component as well as a XAML component. Start by removing the btnRemoveCar_Click event handler in the MainWindow.xaml.cs class.

Adding the Command Class

Next, add another class to the Cmds folder named RemoveCarCommand, make the class internal, and derive from CommandBase. This command will be acting on the list of Inventory records in the View, so create a field for an IList<Inventory> named _cars and a constructor to accept an existing list. The code should look like this:

```
internal class RemoveCarCommand : CommandBase
{
    private readonly IList<Inventory> _cars;

    public RemoveCarCommand(IList<Inventory> cars)
    {
        _cars = cars;
    }
}
```

Just like the Execute method of the ChangeColorCommand, this method receives an Inventory record as the parameter. Override the Execute method, cast the parameter to an Inventory object, and then remove it from the list, as follows:

```
public override void Execute(object parameter)
{
    _cars.Remove((Inventory)parameter);
}
```

Finally, override the CanExecute method, and add the same code as you did for the ChangeColorCommand: to return false if the parameters is null or not an inventory object, and return true otherwise. The code looks like this:

```
public override bool CanExecute(object parameter) =>
    (parameter as Inventory) != null && _cars != null && _cars.Count != 0;
}
```

Updating the XAML

Remove the `Click` attribute from the `btnRemoveCar` Button, and add the `Command` and `CommandParameter` properties, as follows:

```
<Button x:Name="btnRemoveCar" Content="Remove Car" Margin="5,0,5,0" Padding="4,2"
  Command="{Binding Path=RemoveCarCmd,
    RelativeSource={RelativeSource Mode=FindAncestor, AncestorType={x:Type Window}}}"
  CommandParameter="{Binding ElementName=cboCars, Path=SelectedItem}"/>
```

Adding the AddCarCommand

Remove the `AddCar_Click` event handler in the `MainWindow.xaml.cs` file.

Adding the Command Class

Start by adding another class to the `Cmds` folder named `AddCarCommand`, make the class internal, and derive from `CommandBase`. This command will also be acting on the list of `Inventory` records in the View, so create a field for an `IList<Inventory>` named `_cars`, and a constructor to accept an existing list. The code should look like this:

```
internal class AddCarCommand : CommandBase
{
    private readonly IList<Inventory> _cars;

    public AddCarCommand(IList<Inventory> cars)
    {
        _cars = cars;
    }
}
```

Unlike the other commands that you have created, you will not be receiving any values from the View. This means that you can ignore the parameter in both the `CanExecute` and `Execute` methods. In the `Execute` method, add another entry into the `_cars` list.

```
public override void Execute(object parameter)
{
    var maxCount = _cars?.Max(x => x.CarId) ?? 0;
    _cars?.Add(new Inventory { CarId = ++maxCount, Color = "Yellow", Make = "VW", PetName = "Birdie",
        IsChanged = false });
}
```

Override the `CanExecute` method and just return `true`, like this:

```
public override bool CanExecute(object parameter) => true;
```

Updating the XAML

Finally, update the XAML to remove the `Click` attribute and add the `Command` attribute, as follows:

```
<Button x:Name="btnAddCar" Content="Add Car" Margin="5,0,5,0" Padding="4,2"
        Command="{Binding Path=AddCarCmd,
        RelativeSource={RelativeSource Mode=FindAncestor, AncestorType={x:Type Window}}}" />
```

■ **Source Code** The `Commands` project can be found in the [Chapter 30](#) subdirectory.

Fully Implementing MVVM

The final exercise with this sample is to finish converting it to MVVM. You might ask why I chose to say “finish” converting. The reason is that everything you have done in this chapter is all related to how MVVM works in WPF, and it is all intertwined in the pattern. Start by adding a new folder called `ViewModels`. In this folder, add a class named `MainWindowViewModel`.

■ **Note** A popular convention is to name the view models after the window they support. However, like any pattern or convention, this isn't a rule, and you will find a wide range of opinions on this.

Moving the Data Source Out of the View

If you recall from the explanation of the MVVM pattern, the only code in the code-behind should be directly related to the UI. Any data needed by the View should be exposed to the View from the ViewModel (and optimally brought to the ViewModel from a repository). In your current project, the data is hard-coded in the code-behind, so the first step is to move the `Cars` collection from the code-behind to the View Model.

Start by adding a public property of type `IList<Inventory>` named `Cars`. In the constructor for the `ViewModel`, set the `Cars` property to a new `ObservableCollection<Inventory>`.

■ **Note** In a real application, this would usually be a call to a repository class or a web service to get the data.

Your class should look like this:

```
public class MainWindowViewModel
{
    public IList<Inventory> Cars { get; set; }
    public MainWindowViewModel()
    {
        Cars = new ObservableCollection<Inventory>
        {
            new Inventory {CarId=1,Color="Blue",Make="Chevy",PetName="Kit", IsChanged = false},
            new Inventory {CarId=2,Color="Red",Make="Ford",PetName="Red Rider", IsChanged = false },
        };
    }
}
```

In `MainWindow.xaml.cs`, delete the old creation of the list (in the constructor), and the line setting the `ItemSource` for the `ComboBox` to the list. Leave the backing field (`_cars`) for now; you don't need it, but two of the commands require it, and deleting it now would make the compile fail. The only code left in your constructor should be `InitializeComponent`, like this:

```
public MainWindow()
{
    InitializeComponent();
}
```

Recall that if a binding expression doesn't specify a data context, it walks up the element tree until it finds a data context. In MVVM, the `ViewModel` class serves as the data context for the entire `Window`, so set the `Window`'s data context to the `ViewModel` in the constructor. Add a `using` for `MVVM.ViewModels`, like this:

```
public partial class MainWindow:Window
{
    public MainWindow()
    {
        InitializeComponent();
        this.DataContext = new MainWindowViewModel();
    }
}
```

The final change to make to the `Window` is to add the `ItemSource` back to the `ComboBox`. Open `MainWindow.xaml`, add the `ItemSource` attribute to the `ComboBox`, and bind it to the `Cars` property on the `ViewModel`. You don't have to specify the data source since the `ViewModel` is the data context for the `Window`. Your markup should look like this:

```
<ComboBox Name="cboCars" Grid.Column="1" DisplayMemberPath="PetName"
    ItemSource="{Binding Path=Cars}"/>
```

Run the app, and see that indeed the combo box is populated with the initial `Cars` collection. After you test the app, delete the `_cars` field from `MainWindow.xaml.cs`. Next, you will move the commands and related code to the `ViewModel`.

Moving the Commands to the ViewModel

Cut and paste the commands from `MainWindow.xaml.cs` into `MainWindowViewModel.cs`. You will have to update the constructor for `AddCarCommand` and `RemoveCarCommand` to use the `Cars` property instead of the `_cars` field. Add a `using` statement for `MVVM.Cmds`. Your code in the `MainWindowViewModel` will look like this:

```
private ICommand _changeColorCommand = null;
public ICommand ChangeColorCmd =>
    _changeColorCommand ?? (_changeColorCommand = new ChangeColorCommand());

private ICommand _addCarCommand = null;
public ICommand AddCarCmd =>
    _addCarCommand ?? (_addCarCommand = new AddCarCommand(Cars));
```



```
private ICommand _removeCarCommand = null;
public ICommand RemoveCarCmd =>
    _removeCarCommand ?? (_removeCarCommand = new RemoveCarCommand(Cars));
private bool CanAddCar() => Cars != null;
```

Finally, open `MainWindow.xaml`, and add `DataContext` to the `Path` for each of the `Button` `Command` binding statements.

```
<Button x:Name="cmdAddCar" Content="Add Car" Margin="5,0,5,0" Padding="4,2"
    Command="{Binding Path=DataContext.AddCarCmd,
    RelativeSource={RelativeSource Mode=FindAncestor, AncestorType={x:Type Window}}}" />
<Button x:Name="cmdChangeColor" Content="Change Color" Margin="5,0,5,0" Padding="4,2"
    Command="{Binding Path=DataContext.ChangeColorCmd,
    RelativeSource={RelativeSource Mode=FindAncestor, AncestorType={x:Type Window}}}"
    CommandParameter="{Binding ElementName=cboCars, Path=SelectedItem}" />
<Button x:Name="btnRemoveCar" Content="Remove Car" Margin="5,0,5,0" Padding="4,2"
    Command="{Binding Path=DataContext.RemoveCarCmd,
    RelativeSource={RelativeSource Mode=FindAncestor, AncestorType={x:Type Window}}}"
    CommandParameter="{Binding ElementName=cboCars, Path=SelectedItem}" />
```

Run the app, and you will see that the buttons work as expected. The code-behind file now only has two lines in it, for the `InitializeComponent` and to set the `DataContext`.

■ **Source Code** The MVVM project can be found in the [Chapter 30](#) subdirectory.

Updating AutoLotDAL for MVVM

You are probably thinking at this point “Great, if I ever need to build an app with one model and fake data, I know exactly how to do it!” Well, it’s time to bring real data back into the mix. There are a few optimizations to make before you plug `AutoLotDAL` into an MVVM app.

Updating the AutoLotDAL Models

The first thing that you need to do is update all of the models with the validation code that you created to support `IDataErrorInfo` and `INotifyDataErrorInfo`. Since much of this code is already in a base class, there are only a few changes to make.

Updating the Base Class

You already created a base class in the previous examples. You will add that base class to `AutoLotDAL`, and you will make some changes to it. However, first make a copy of the final `AutoLotDAL` project from [Chapter 23](#) (or from the `MVVMFinal` project in the [Chapter 30](#) downloads) to your WPF examples. Right-click the `Models` folder in `Solution Explorer`, select `Add` ► `Existing item`, and pick the `EntityBase` file from the

previous section's example. Make sure to change the namespace to `AutoLotDAL.Models`, and add usings for `System.ComponentModel.DataAnnotations` and `System.ComponentModel.DataAnnotations.Schema`. Next, add the `TimeStamp` property, like this:

```
[Timestamp]
public byte[] TimeStamp { get; set; }
```

Next, add the `IsChanged` property, like this (remember to add the `NotMapped` attribute since this property won't get stored in the database):

```
[NotMapped]
public bool IsChanged { get; set; }
```

The final change for the `EntityBase.cs` class is to add the `IDataErrorInfo` interface to the class and implement the interface. Make sure to mark the indexer method as virtual, since the actual implementation will be in the `Model` classes:

```
public virtual string this[string columnName] { get { throw new NotImplementedException(); } }
public string Error { get; }
```

Next, open each of the model classes (`Inventory`, `Customer`, `Order`, and `CreditRisk`), delete the `TimeStamp` field, and add the `EntityBase` as the base class for all of them. In a real application, you usually create partial classes for each model class and add the `EntityBase` base class there. For the sake of simplicity, in this example, you are just adding them to the model classes instead of creating partial classes.

Updating the Inventory Partial

Copy the string indexer from the `InventoryPartial.cs` class from the `Commands` example into the `InventoryPartial.cs` class of `AutoLotDAL`. It should look like this:

```
public string this[string columnName]
{
    get
    {
        string[] errors = null;
        bool hasError = false;
        switch (columnName)
        {
            case nameof(CarId):
                errors = GetErrorsFromAnnotations(nameof(CarId), CarId);
                break;
            case nameof(Make):
                hasError = CheckMakeAndColor();
                if (Make == "ModelT")
                {
                    AddError(nameof(Make), "Too Old");
                    hasError = true;
                }
                errors = GetErrorsFromAnnotations(nameof(Make), Make);
                break;
        }
    }
}
```

```

    case nameof(Color):
        hasError = CheckMakeAndColor();
        errors = GetErrorsFromAnnotations(nameof(Color), Color);
        break;
    case nameof(PetName):
        errors = GetErrorsFromAnnotations(nameof(PetName), PetName);
        break;
}
if (errors != null && errors.Length != 0)
{
    AddErrors(columnName, errors);
    hasError = true;
}
if (!hasError) ClearErrors(columnName);
return string.Empty;
}
}

```

This has (for the most part) brought the features you’ve learned about in this chapter into AutoLotDAL. The one item that is missing is `INotifyPropertyChanged`, which you will add next.

Implementing `INotifyPropertyChanged`

You might have noticed that you didn’t add `INotifyPropertyChanged` to the `EntityBase` class or any of your model classes. If you add `INotifyPropertyChanged` to the models, you have to update each and every setter to raise the `PropertyChangedEvent` (or call into the `OnPropertyChanged` event). This is not a huge task for a project as small as this, but it becomes a major pain in projects of any significant size. You also run the risk of losing all of your work if your model classes are generated from an ORM and they need to be regenerated.

Fortunately, some very smart minds have solved this predicament. There is an open source project called `PropertyChanged.Fody` that addresses this very concern. This project is an extension for `Fody` (<https://github.com/Fody/Fody/>), an open source tool for weaving .NET assemblies. Weaving is the process of manipulating the IL generated during the build process. `PropertyChanged.Fody` adds in all of the plumbing code for `INotifyPropertyChanged` for you, and if you have a property named `IsChanged`, it will be updated when another property changes, just as you did manually in the earlier example in this chapter.

■ **Note** You can find more information about the `PropertyChanged` project at <https://github.com/Fody/PropertyChanged>.

To install the necessary packages, right-click your project name, select `Manage NuGet packages`, and search for “`propertychanged.fody`”. You will see something similar to [Figure 30-14](#) (the version might be different based on when you are reading this).

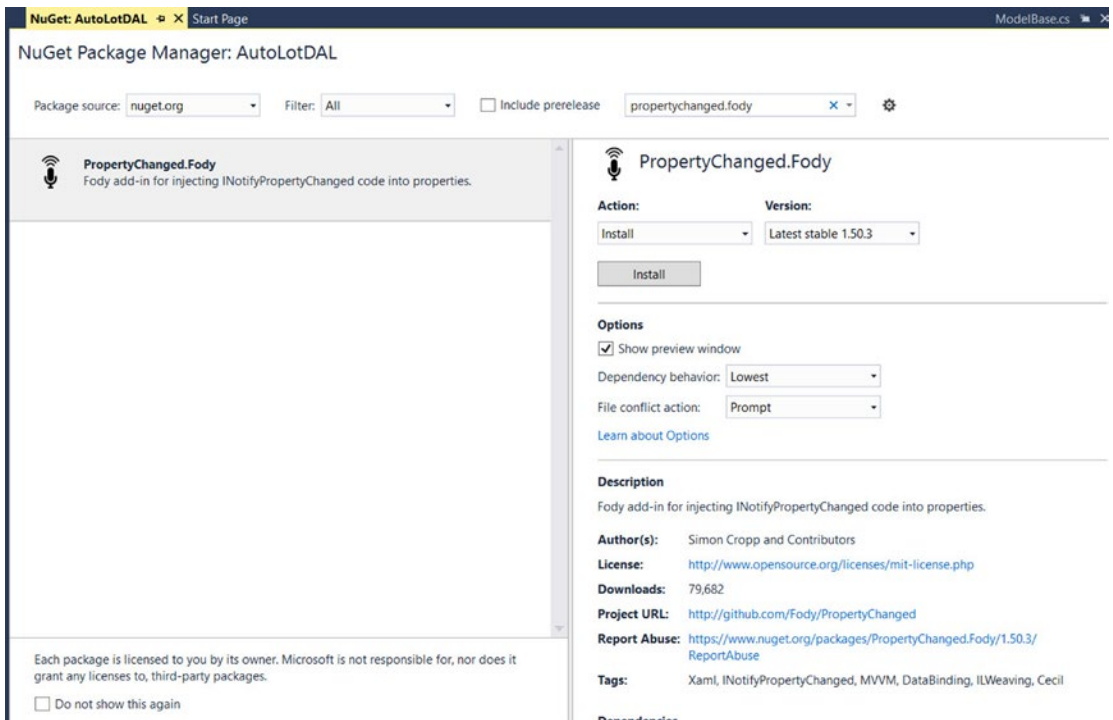

Figure 30-14. Installing *PropertyChanged.Fody*

Once that is done, open up *ModelBase*, and add the attribute `[ImplementPropertyChanged]` at the class level. That's all you have to do!

Full MVVM Example

Now that you have updated *AutoLotDAL*, you will integrate real data into the last example. Copy the project from the Fully Implementing MVVM section to a new location. Open the project, and add *AutoLotDAL* by right-clicking the project name in the Solution Explorer and selecting **Add** ► **Existing Project**.

Add a reference to the *AutoLotDAL* from your WPF project. Add *EntityFramework* to the WPF project by right-clicking the solution and selecting **Manage NuGet Packages for Solution**. Select *EntityFramework* (by filtering on **Installed** if necessary), and select the WPF project for install. Update the `app.config` to add the `ConnectionStrings` node and the `ConnectionString` for your database. Your exact string might vary, but it should look something like this:

```
<connectionStrings>
  <add name="AutoLotConnection" connectionString="data source=.\SQLEXPRESS2014;initial
catalog=AutoLot;integrated security=True;MultipleActiveResultSets=True;App=EntityFramework"
providerName="System.Data.SqlClient" />
</connectionStrings>
```

Open the `MainWindowViewModel.cs` file, and add usings for `AutoLotDAL.Models` and `AutoLotDAL.Repos`. Update the constructor to get all of the `Inventory` records from the `InventoryRepo` class, instead of manually creating the list. The new constructor should look like this:

```
public MainWindowViewModel()
{
    Cars = new ObservableCollection<Inventory>(new InventoryRepo().GetAll());
}
```

Open all of the command classes, update the namespaces to use `AutoLotDAL.Models`, and remove the `MVVM.Models` namespace (or whatever the namespace is in your example). Finally, delete all of the classes in the `Models` directory of the WPF project.

Run the app, and you will see all of the records in the drop-down, as shown in Figure 30-15.

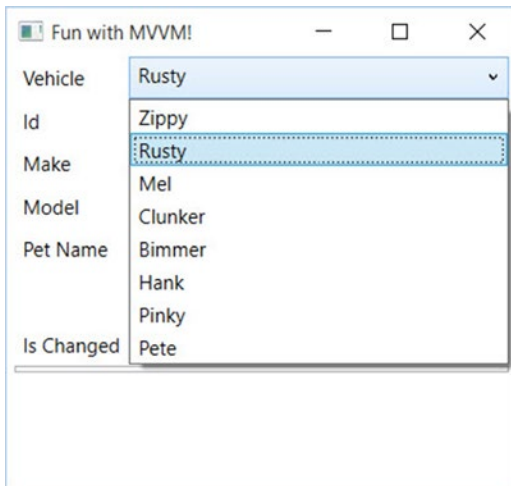

Figure 30-15. Pulling data from the database

One problem you might notice is that every vehicle has the `IsChanged` check box checked. This is because EF materializes each record by setting the properties, which of course triggers the `PropertyChanged` code and sets the `IsChanged` flag. In the next section, you will learn how to handle this gracefully in EF.

Using ObjectMaterialized with Entity Framework

If you recall from Chapter 23, the `ObjectMaterialized` event fires every time EF is done reconstituting an object from the database. Open up `AutoLotEntities.cs`, and in the `OnObjectMaterialized` event handler, check to see if the `Entity` property of the `ObjectMaterializedEventArgs` is of type `EntityBase`. If it is, then set the `IsChanged` property to false. The code will look like this:

```
private void OnObjectMaterialized(object sender, ObjectMaterializedEventArgs e)
{
    var model = (e.Entity as EntityBase);
    if (model != null)
```

```
{  
    model.IsChanged = false;  
}  
}
```

Run the app. Select a record from the drop-down, and you will see that the `IsChanged` flag is no longer set when the form first loads. If you edit a field, the `IsChanged` flag still gets set correctly.

Summary

This chapter examined the WPF topics that support the Model-View-ViewModel (MVVM) pattern. You started off learning how to tie model classes and collections into the notification system in the binding manager. You implemented `INotifyPropertyChanged`, and used `ObservableCollections` to keep the UI in sync with the bound data. Later in the chapter, you learned how to use `PropertyChanged.Fody` to do this work automatically.

Next, you added validation code to the Model using `IDataErrorInfo`, `INotifyDataErrorInfo`, and checked for Data Annotation errors. You then displayed any validation errors in the UI so the user would know what the problem is and how to fix it.

Finally, you put it all together by adding a `ViewModel`, and you cleaned up the UI markup and code-behind file to increase separation of concerns. You updated `AutoLotDAL` to add validation and notifications, and used `ObjectMaterialized` to clean up the objects as they materialize.

PART VIII



ASP.NET

CHAPTER 31



Introducing ASP.NET Web Forms

Until now, all of the examples in this book have focused on console-based and desktop graphical user interfaces created using the WPF platform. The remainder of the text will explore how the .NET platform facilitates the construction of Internet-based applications using a technology named ASP.NET. This and the next two chapters cover ASP.NET Web Forms, and Chapter 34 covers ASP.NET MVC and ASP.NET Web API. To begin, you'll quickly overview a number of key web development concepts (HTTP, HTML, client-side scripting, postbacks) and examine the role of Microsoft's commercial web server (IIS) as well as that of the IIS Express.

■ **Note** This chapter and the next two cover ASP.NET Web Forms, the original web development framework in .NET. Chapter 34 covers ASP.NET MVC and ASP.NET Web API, two (fairly recent) additions to the ASP.NET family of framework.

With this brief web primer out of the way, the remainder of this chapter will concentrate on the structure of the ASP.NET web form programming model (including the single-page and code-behind model) and examine the functionality of the Page base class. Along the way, you'll be introduced to the role of ASP.NET web controls, the directory structure of an ASP.NET web site, and how to use a `Web.config` file to control the runtime operation of your web sites.

The Role of HTTP

Web applications are very different animals from graphical desktop applications. The first obvious difference is that a production-level web application involves at least two networked machines: one hosting the web site and the other viewing data within a web browser. Of course, during development it is entirely possible to have a single machine play the role of both the browser-based client and the hosting web server that serves up content. Given the nature of web applications, the networked machines in question must agree upon a particular wire protocol to determine how to send and receive data. The wire protocol that connects the computers in question is the Hypertext Transfer Protocol (HTTP).

The HTTP Request/Response Cycle

When a client machine launches a web browser (such as Google Chrome, Opera, Mozilla Firefox, Apple Safari, or Microsoft Internet Explorer/Edge), an HTTP *request* is made to access a particular resource (typically a web page) on the remote server machine. HTTP is a text-based protocol that is built upon a standard request/response paradigm. For example, if you navigate to <http://www.facebook.com>, the browser software leverages a web technology termed *Domain Name Service* (DNS) that converts the registered URL

into a numerical value termed an *IP address*. At this point, the browser opens a socket connection (typically via port 80 for a nonsecure connection) and sends the HTTP request for processing to the target site.

The web server receives the incoming HTTP request and may choose to parse out any client-supplied input values (such as values within a text box, check box, or list box) in order to format a proper HTTP *response*. Web programmers may leverage any number of server-side technologies (PHP, ASP.NET, JSP, etc.) to dynamically generate the content to be emitted into the HTTP response. At this point, the client-side browser renders the returned HTML sent from the web server. Figure 31-1 illustrates the basic HTTP request/response cycle.

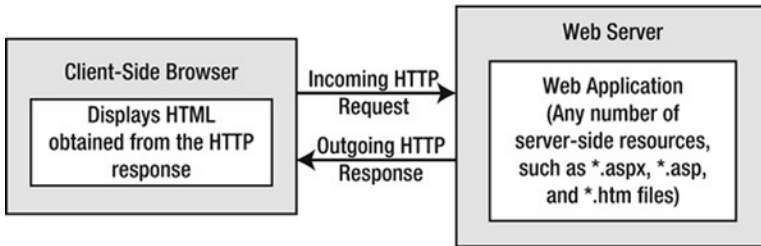

Figure 31-1. The HTTP request/response cycle

HTTP Is a Stateless Protocol

Another aspect of web development that is markedly different from traditional desktop programming is the fact that HTTP is essentially a *stateless* wire protocol. As soon as the web server sends a response to the client browser, everything about the previous interaction is forgotten. This is certainly not the case in a traditional desktop application, where the state of the executable is most often alive and kicking until the user shuts down the main window of the application.

Given this point, as a web developer, it is up to you take specific steps to “remember” information (such as items in a shopping cart, credit card numbers, and home addresses) about the users who are currently logged on to your site. As you will see in Chapter 33, Web Forms provide numerous ways to handle state, using techniques such as session variables, cookies, and the application cache as well as the Web Forms profile management API.

Understanding Web Applications and Web Servers

A *web application* can be understood as a collection of files (e.g., *.html, *.aspx, image files, XML-based file data) and related components (such as a .NET code library) stored within a particular set of directories on a web server. As shown in Chapter 33, Web Forms applications have a specific life cycle and provide numerous events (such as initial startup or final shutdown) that you can hook into in order to perform specialized processing during your web site’s operation.

A *web server* is a software product in charge of hosting your web applications; it typically provides a number of related services such as integrated security, File Transfer Protocol (FTP) support, mail exchange services, and so forth. Internet Information Services (IIS) is the Microsoft enterprise-level web server product, and it offers intrinsic support for Web Forms applications.

Assuming you have IIS properly installed on your workstation, you can interact with IIS from the Administrative Tools folder (located in the Control Panel folder) by double-clicking the Internet Information Services Manager applet. Figure 31-2 shows the Default Web Site node of IIS where a majority of the configuration details occur (if you are running earlier versions of IIS, your UI will look different).

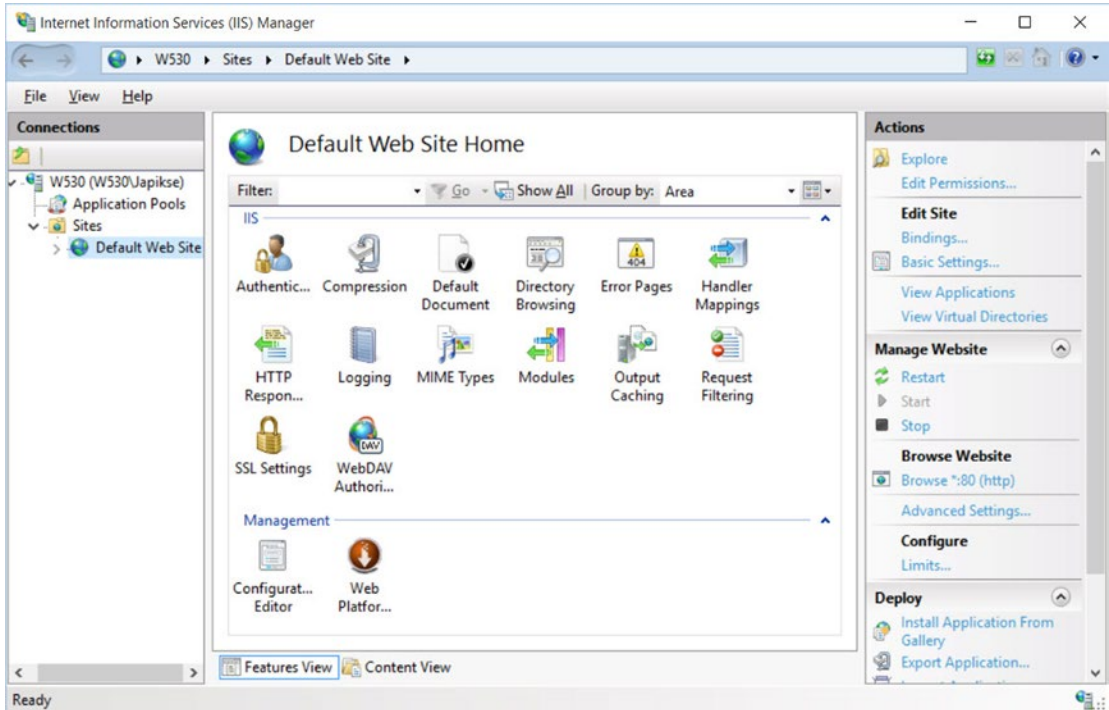

Figure 31-2. The IIS applet can be used to configure the runtime behavior of Microsoft IIS

The Role of IIS Virtual Directories

A single IIS installation is able to host numerous web applications, each of which resides in a *virtual directory*. Each virtual directory is mapped to a physical directory on the machine's hard drive. For example, if you create a new virtual directory named `CarsAreUs`, the outside world can navigate to this site using a URL such as `http://www.MyDomain.com/CarsAreUs` (assuming your site's IP address has been registered with a DNS of `www.MyDomain.com`). Under the hood, this virtual directory maps to a physical root directory on the web server that contains the content of the `CarsAreUs` web application.

As you will see later in this chapter, when you create Web Forms applications using Visual Studio, you have the option of having the IDE generate a new virtual directory for the current web site automatically. However, if required, you are certainly able to manually create a virtual directory by hand by right-clicking the Default Web Site node of IIS and selecting Add Virtual Directory from the context menu.

IIS Express

In earlier versions of the .NET platform, ASP.NET developers were required to make use of IIS virtual directories during the development and testing of their web applications. In many cases, this tight dependency on IIS made team development more complex than necessary, not to mention that many network administrators frowned upon installing IIS on every developer's machine.

Happily, there is the option of a lightweight web server named IIS Express. This utility allows developers to host a Web Forms application outside the bounds of IIS. Using this tool, you can build and test your web pages from any folder on your machine. This is quite helpful for team development scenarios and for building Web Forms applications on versions of Windows that do not support IIS installations.

Most of the examples in this book will make use of IIS Express (via the correct Visual Studio project option) rather than hosting web content under an IIS virtual directory. While this approach can simplify the development of your web application, be aware that this web server is *not* intended to host production-level web applications. It is intended purely for development and testing purposes. When your web application is ready for prime time, your site will need to be copied to an IIS virtual directory.

■ **Note** Visual Studio provides a built-in tool to copy a local web application to a production-level web server. Doing so is as simple as the click (or two) of a button. To start the process, you need to select your web project in the Visual Studio Solution Explorer, right-click, and select Publish. At this point you can select the intended destination of the deployment, including Microsoft Azure.

The Role of HTML

After you have configured a directory to host your web application and you have chosen a web server to serve as the host, you need to create the content itself. Recall that a web application is simply a set of files that constitute the functionality of the site. To be sure, many of these files will contain Hypertext Markup Language (HTML) statements. HTML is a standard markup language used to describe how literal text, images, external links, and various HTML controls are to be rendered within the client-side browser.

While it is true that modern IDEs (including Visual Studio) and web development platforms (such as ASP.NET) generate much of the HTML automatically, you should have a working knowledge of HTML as you work with ASP.NET.

■ **Note** Recall from Chapter 2 that Microsoft has released a number of free IDEs under the Express family of products as well as Visual Studio Community Edition, which rolls all of the Express editions into one package. To work through the next chapters on WebForms, MVC, and Web API, you can download Visual Studio Express for Web or Community Edition.

While this section will most certainly not cover all aspects of HTML, it will touch on some basics. This will help you better understand the markup generated on your behalf by the Web Forms programming model.

HTML Document Structure

A typical HTML file consists of a set of tags that describe the look and feel of a given web page. The basic structure of an HTML document tends to remain the same. For example, *.html files open and close with <html> and </html> tags, typically define a <body> section, and so forth.

To get started, open Visual Studio and select New ► Project. Under Other Project Types, select Visual Studio Solutions, and chose Blank Solution, as in Figure 31-3 (notice that you are not making a web project at this point, you are just creating a blank solution to hold your files).

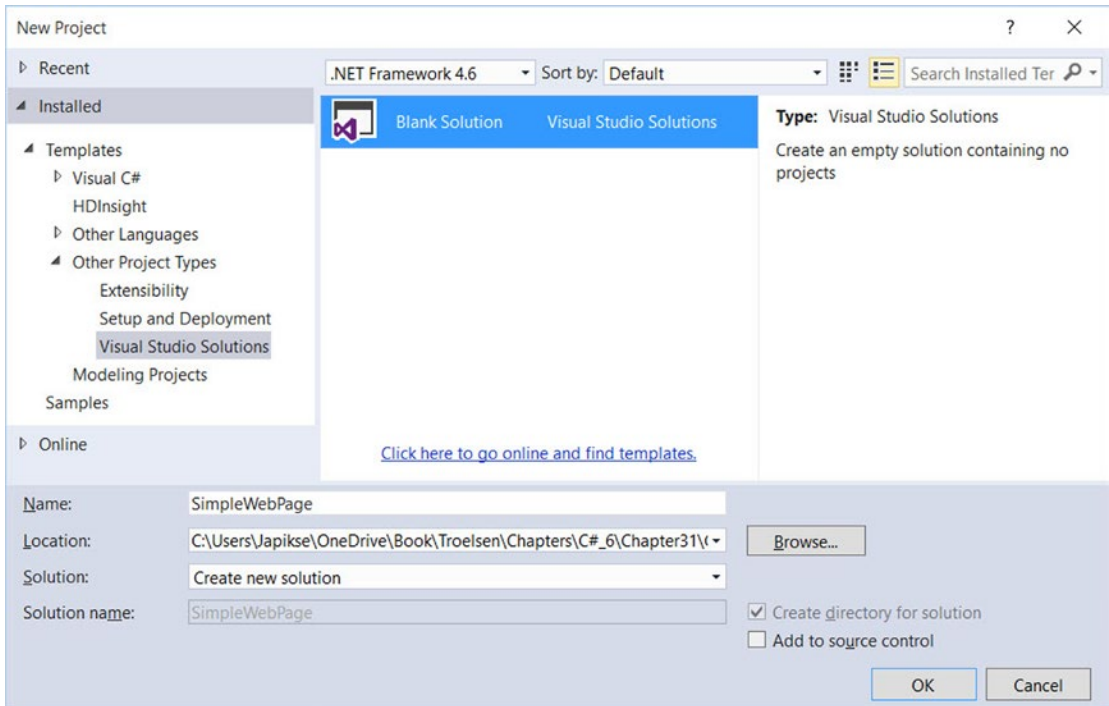

Figure 31-3. Select Blank Visual Studio Solution from the New Project dialog

Next, add an empty HTML Page file via the Project ► Add New Item menu selection, and select Visual C#/Web in the left rail and HTML Page in the center pane. Name the file `HtmlPage1.html`. You should see some initial markup such as the following (the exact HTML may differ based on how you have configured Visual Studio):

```
<!DOCTYPE html>

<html lang="en" xmlns="http://www.w3.org/1999/xhtml">
<head>
  <title> </title>
  <meta charset="utf-8" />
</head>
<body>

</body>
</html>
```

First, notice that this HTML file opens with a DOCTYPE processing instruction. This, in conjunction with the opening `<html>` tag establishes that the contained HTML tags should be validated against the HTML 5.0 standard. The HTML 5.0 standard is a W3C specification that adds many new features to vanilla-flavored markup.

■ **Note** By default, Visual Studio validates all HTML documents against the HTML 5.0 validation scheme to ensure the markup is in sync with the HTML 5 standard. If you need to specify an alternative validation scheme, activate the Tools ► Options dialog box, expand the Text Editor node, expand the HTML (Web Forms) node, and then select the Validation node. On a related note, if you would rather not see validation warnings, simply uncheck the Show Errors check box found in the same location.

To spruce things up just a bit, update the title of your page like so:

```
<head>
  <title>This is my simple web page</title>
</head>
```

Not surprisingly, the `<title>` tags are used to specify the text string that should be placed in the title bar of the hosting web browser.

The Role of an HTML Form

An *HTML form* is simply a named group of related UI elements, typically used to gather user input. Do not confuse an HTML form with the entire display area shown by a given browser. In reality, an HTML form is more of a *logical grouping* of widgets placed in the `<form>` and `</form>` tag set, such as

```
<!DOCTYPE html>

<html xmlns="http://www.w3.org/1999/xhtml">

  <head>
    <title>This is my simple web page</title>
  </head>
  <body>
    <form id="defaultPage">
      <!-- Insert web UI content here -->
    </form>
  </body>
</html>
```

This form has been assigned the id of "defaultPage". Typically, the opening `<form>` tag supplies an action attribute that specifies the URL to use to submit the form data, as well as the method of transmitting that data itself (POST or GET). You will learn more about this in the next section. For the time being, let's look at the sorts of items that can be placed in an HTML form (beyond simple literal text).

The Visual Studio HTML Designer Tools

Visual Studio provides an HTML tab on the Toolbox (accessible through the View ► Toolbox menu option) that allows you to select an HTML control that you may place on your HTML designer (see Figure 31-4). Similar to the process of building a WPF application, these HTML controls can be dragged onto the designer surface or directly into the markup of the page.

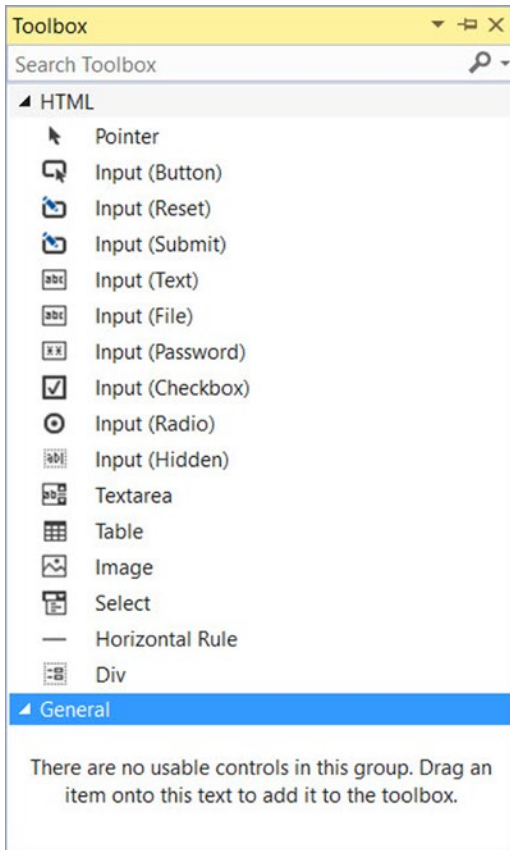

Figure 31-4. The HTML tab of the Toolbox

■ **Note** When you are building Web Forms pages using the web form programming model, you will typically not be using these HTML controls to create the user interface. Rather, you will use the Web Forms controls, which will render back the correct HTML on your behalf. You'll learn about the role of web controls a bit later in this chapter.

The HTML editor doesn't have a designer surface. In order to use a designer (or Split Mode), you need to use the Web Forms HTML Editor. To do this, close the editor for `HtmlPage1.html`, and in the Solution, right-click the file, select **Open With**, and you will see a dialog that allows you to choose which editor (shown in Figure 31-5). If you click **Set as Default**, then you would not need to create a solution like we did here because the Web Forms HTML Editor will always be used.

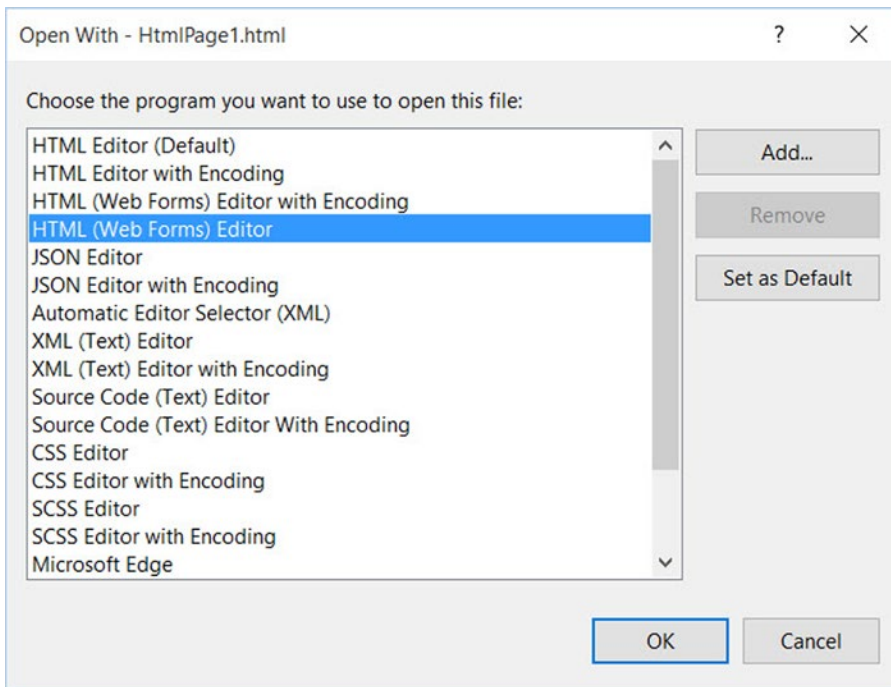

Figure 31-5. *Selecting the WebForms Editor*

If you click the Split button on the bottom of the HTML editor, the bottom pane of the HTML editor will display the HTML visual layout and the upper pane will show the related markup. Another benefit of this editor is that as you select markup or an HTML UI element, the corresponding representation is highlighted. Figure 31-6 shows an example of the split view in action.

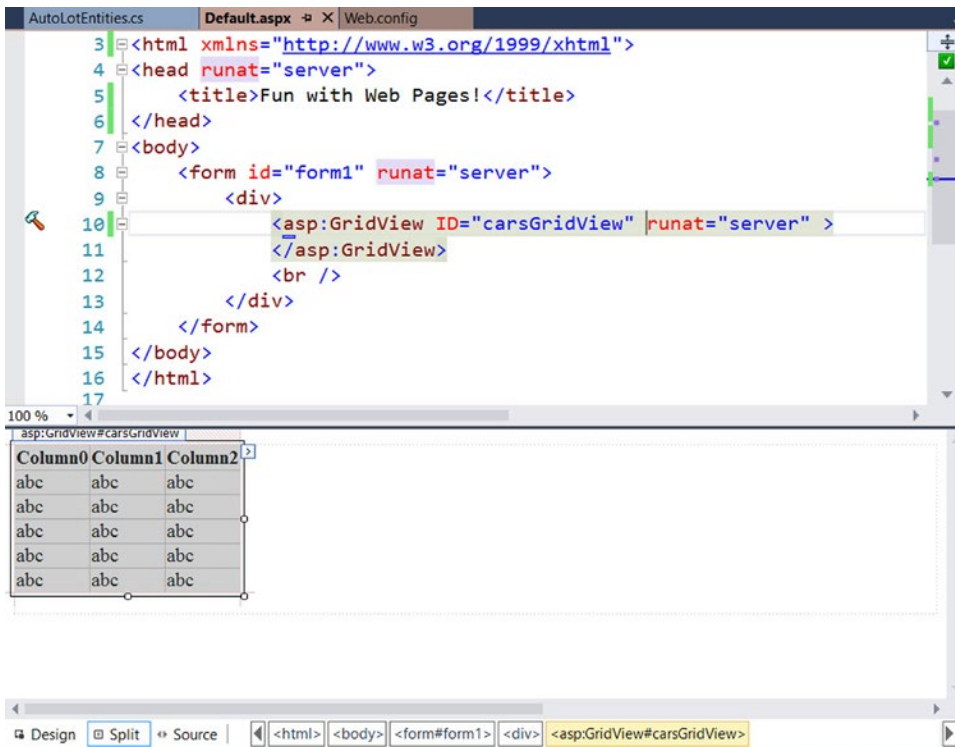

Figure 31-6. The Visual Studio Web Forms HTML designer

Visual Studio also allows you to edit the overall look and feel of the *.html file or a given HTML control in the <form> using the Properties window. For example, if you select DOCUMENT from the drop-down list of the Properties window, you can configure various aspects of the HTML page (see Figure 31-7).

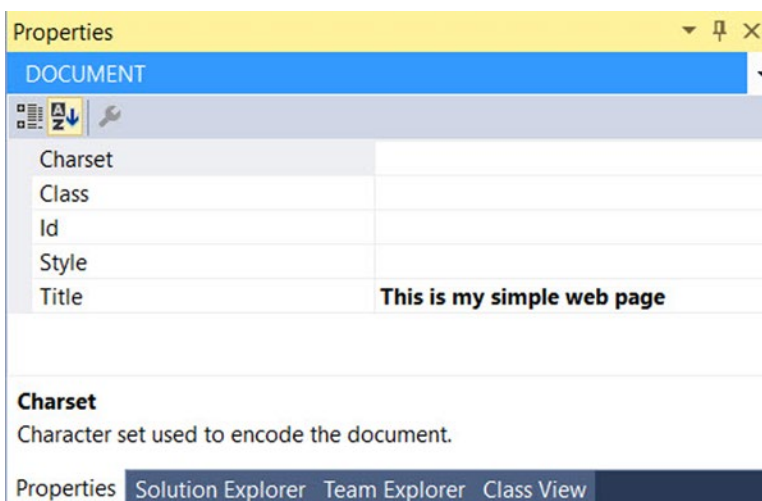

Figure 31-7. The Visual Studio Properties window can be used to configure the HTML markup

As you use the Properties window to configure an aspect of your web page, the IDE will update the HTML accordingly. Feel free to use the IDE to help edit your HTML pages as you read over the remaining chapters of the book.

Building an HTML Form

Update the `<body>` of the initial file to display some literal text that prompts the user to enter a message. Be aware that you can enter and format literal textual content by typing directly in the HTML designer. Here, you are using the `<h1>` tag to set a header weight, `<p>` for a paragraph block, and `<i>` for italic text:

```
<!DOCTYPE html>
<html xmlns="http://www.w3.org/1999/xhtml">
<head>
  <title>This is my simple web page</title>
</head>
<body>
  <!-- Prompt for user input. -->
  <h1>Simple HTML Page</h1>
  <p>
    <br/>
    <i>Please enter a message</i>.
  </p>

  <form id="defaultPage">
  </form>

</body>
</html>
```

Now let's build the form's input area. In general, each HTML control is described using an `id` attribute (used to identify the item programmatically) and a `type` attribute (used to specify which input control you are interested in placing in the `<form>` declaration).

The UI you will build here will contain one text field and two button types. The first button will be used to run a client-side script and the other to reset the form input fields to the default values. Update your HTML form like so:

```
<!-- Build a form to get user info. -->
<form id="defaultPage">
  <p>
    Your Message:
    <input id="txtUserMessage" type="text"/></p>
  <p>
    <input id="btnShow" type="button" value="Show!"/>
    <input id="btnReset" type="reset" value="Reset"/>
  </p>
</form>
```

Notice that you have assigned relevant ids to each control (`txtUserMessage`, `btnShow`, and `btnReset`). Also notice that each input item has an extra attribute named `type` that marks these input controls as UI items that automatically clear all fields to their initial values (`type="reset"`), receive text input (`type="text"`), or function as a simple client-side button that does not post back to the web server (`type="button"`).

Save your file, then right-click on the designer, and select the View in Browser menu option. Figure 31-8 shows the current page with the new Microsoft Edge web browser.

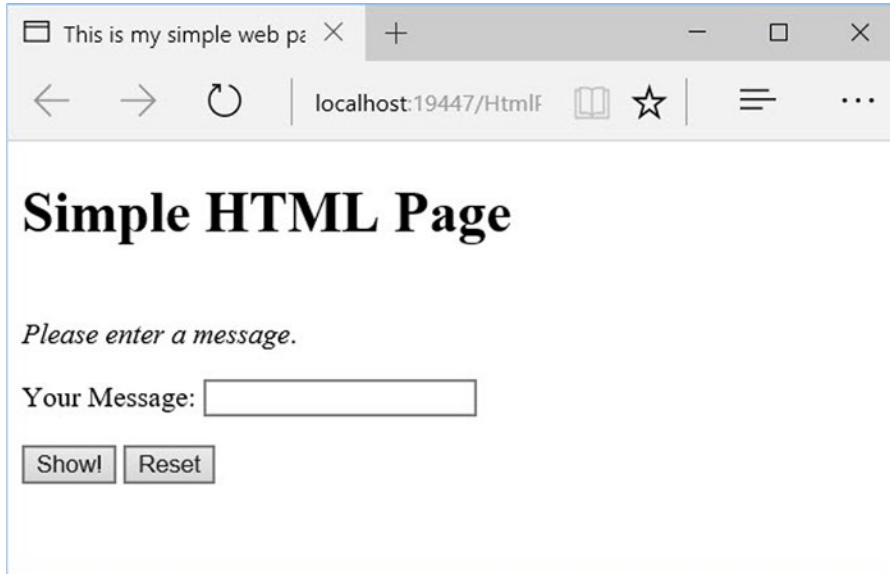

Figure 31-8. Your simple HTML page

■ **Note** When you select the View in Browser option for an HTML file, Visual Studio will automatically launch the IIS Express to host your content.

The Role of Client-Side Scripting

In addition to GUI elements, a given *.html file may contain blocks of script code that will be processed by the requesting browser. The following are two major reasons why client-side scripting is used:

- To validate user input in the browser before posting back to the web server
- To interact with the Document Object Model (DOM) of the browser

Regarding the first point, understand that the inherent evil of a web application is the need to make frequent round-trips (termed *postbacks*) to the server machine to update the HTML to be rendered into the browser. While postbacks are unavoidable, you should always be mindful of ways to minimize travel across the wire. One technique that saves postbacks is to use client-side scripting to validate user input before submitting the form data to the web server. If an error is found, such as not supplying data within a required field, you can alert the user to the error without incurring the cost of posting back to the web server. (After all, nothing is more annoying to users than posting back on a slow connection, only to receive instructions to address input errors!)

■ **Note** Be aware that even when performing client-side validation (for improved response time), validation should *also* occur on the web server itself. This will ensure that the data has not been tampered with while it was sent across the wire. The ASP.NET validation controls automatically perform client and server-side validation (more on this in Chapter 32).

Client-side scripts can also be used to interact with the underlying object model (the Document Object Model, or DOM) of the web browser itself. Most commercial browsers expose a set of objects that can be leveraged to control how the browser should behave.

When a browser parses an HTML page, it builds an object tree in memory, representing all the contents of the web page (forms, input controls, etc.). Browsers provide an API called DOM that exposes the object tree and allows you to modify its contents programmatically. For example, you can write JavaScript that executes in the browser to get the values from specific controls, change the color of a control, add new controls to the page dynamically, and so forth.

One major annoyance is the fact that different browsers tend to expose similar, *but not identical*, object models. Thus, if you emit a block of client-side script code that interacts with the DOM, it might not work identically on all browsers (thus, testing is always a must!).

ASP.NET provides the `HttpRequest.Browser` property, which allows you to determine at runtime the capacities of the browser and the device that sent the current request. You can use this information to stylize how to emit back the HTTP response in the most optimal manner. But you rarely need to worry about this, unless you are implementing custom controls, because all the standard web controls in ASP.NET automatically know how to render themselves appropriately based on the browser type. This remarkable capability is known as *adaptive rendering*, and it's implemented out-of-the-box for all standard ASP.NET controls.

There are various scripting languages that can be used to author client-side script code, but the most popular by far is JavaScript. It's important to note that JavaScript is in no way, shape, or form the same as the Java language. While JavaScript and Java have a somewhat similar syntax, JavaScript is less powerful than Java. The good news is that all modern-day web browsers support JavaScript, which makes it a natural candidate for client-side scripting logic.

A Client-Side Scripting Example

To illustrate the role of client-side scripting, let's first examine how to intercept events sent from client-side GUI widgets. To capture the `click` event for the Show button, update the definition of the `btnShow` widget to support an `onclick` attribute, which is assigned to a JavaScript method named `btnShow_onclick()`.

```
<input id="btnShow" type="button" value="Show!"
      onclick="return btnShow_onclick()" />
```

Now, add the following JavaScript function directly after the opening `<head>` element, which is called when the user clicks the button. Use the `alert()` method to display a client-side message box containing the value in the text box via the `value` property.

```
<script type="text/javascript">
// 
  function btnShow_onclick() {
    alert(window.txtUserMessage.value);
  }
// ]]&gt;
&lt;/script&gt;</pre></div><div data-bbox="68 909 114 925" data-label="Page-Footer">1396</div>
```

Note that the scripting block has been wrapped within a CDATA section. The reason for this is simple: if your page ends up on a browser that does not support JavaScript, the code will be treated as a comment block and ignored. Of course, your page may be less functional, but the upside is that your page will not blow up when rendered by the browser. In any case, if you view your page in a browser once again, you should be able to type a message and see it pop up in a client-side message box (see Figure 31-9).

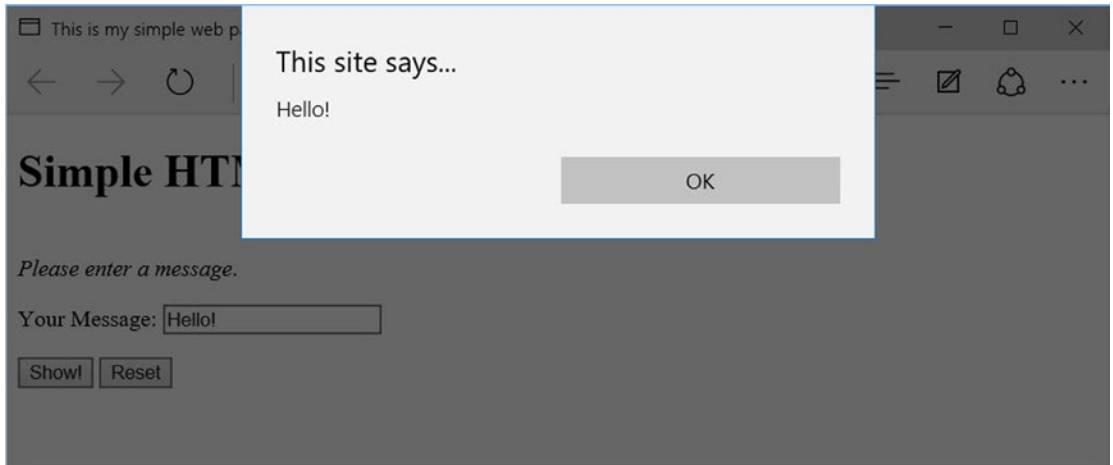

Figure 31-9. Invoking a client-side JavaScript function

As well, when you click the Reset button, you should find that the text area is cleared of data because this particular button was created by specifying `type="reset"`.

Posting Back to the Web Server

This simple HTML page is executing all functionality within the hosting browser. A *real* web page needs to post back to a resource on the web server, passing all of the input data at the same time. Once the server-side resource receives this data, it can use it to build a proper, dynamically generated, HTTP response.

The `action` attribute on the opening `<form>` tag specifies the recipient of the incoming form data. Possible receivers include mail servers, other HTML files on the web server, RESTful web services, a Web Forms page, and so forth.

Beyond the `action` attribute, you will also likely have a `submit` button, which when clicked, will transmit the form data to the web application via an HTTP request. There is no need to do so for this example; however, here is an update to the file, specifying the following attribute in the opening `<form>` tag:

```
<form id="defaultPage"
    action="http://localhost/Cars/MyAspNetPage.aspx" method="GET">
  <input id="btnPostBack" type="submit" value="Post to Server!"/>
  ...
</form>
```

When the submit button for this form is clicked, the form data is sent to the `MyAspNetPage.aspx` at the specified URL. When you specify `method="GET"` as the mode of transmission, the form data is appended to the query string as a set of name/value pairs separated by ampersands. You might have seen this sort of data in your browser before; it looks like the following:

```
http://www.google.com/search?hl=en&source=hp&q=vikings&cts=1264370773666&aq=f&aql=&aqi=g1g-z1g1g-z1g1g-z1g4&oq=
```

The other method of transmitting form data to the web server is to specify `method="POST"`, like so:

```
<form id="defaultPage"
  action="http://localhost/Cars/MyAspNetPage.aspx" method = "POST">
...
</form>
```

In this case, the form data is not appended to the query string. Using POST, the form data is not directly visible to the outside world. More important, POST data does not have a character-length limitation; many browsers have a limit for GET queries.

Postbacks Under Web Forms

When you are building Web Forms-based web sites, the framework will take care of the posting mechanics on your behalf. One of the many benefits of building a web site using ASP.NET Web Forms is that the programming model layers on top of the standard HTTP request/response protocol of an event driven system. Thus, rather than manually setting an `action` attribute and defining an HTML submit button, you can simply handle events on the Web Forms controls using standard C# syntax.

Using this event-driven model, you can very easily post back to the web server using a large number of controls. If you require, you can post back to the web server if the user clicks on a radio button, an item in a list box, a day on a calendar control, and so on. In each case, you simply handle the correct event, and the ASP.NET runtime will automatically emit back the correct HTML posting data.

■ **Source Code** The SimpleWebPage web site is included in the Chapter 31 subdirectory.

An Overview of the Web Forms API

At this point, your whirlwind review of classic web application development is complete, and you are ready to dive into Web Forms. As you would expect, each edition of the .NET platform adds more functionality to the web programming APIs, and this is certainly true under .NET 4.6. Regardless of which version of .NET you happen to be targeting, the following features are commonplace for ASP.NET Web Forms-based applications:

- ASP.NET provides a model termed *code-behind*, which allows you to separate presentation logic (HTML) from business logic (C# code).
- ASP.NET pages are coded using .NET programming languages, rather than server-side scripting languages. The code files are compiled into valid .NET *.dll assemblies (which translates into much faster execution).
- Web Forms controls can be used to build a web UI in a model similar to that of building a desktop windows application.

- Web Forms applications can make use of any of the assemblies within the .NET base class libraries and are constructed using the object-oriented techniques examined in this book (classes, interfaces, structures, enums, and delegates).
- Web Forms applications can be easily configured via a web application configuration file (`Web.config`).

The first point I want to elaborate on here is the fact that the UI of a Web Forms web page can be constructed using various *web controls*. Unlike a typical HTML control, web controls are executed on the web server and will emit back to the HTTP response their correct HTML tags. This alone is a huge benefit of Web Forms in that the amount of HTML you must manually author by hand diminishes greatly. By way of a quick example, assume you have defined the following Web Forms web control in a Web Forms page (I'll cover creating the details of how to do this shortly):

```
<asp:Button ID="btnMyButton" runat="server" Text="Button" BorderColor="Blue"
  BorderStyle="Solid" BorderWidth="5px" />
```

You'll learn the details of declaring Web Forms controls soon enough, but for right now, notice that many attributes of the `<asp:Button>` control look very similar to the properties you encountered in the WPF examples. The same is true for all Web Forms controls because when Microsoft built the web control toolkit, these widgets were purposely designed to look and feel like their desktop counterparts.

Now, if a browser makes a call to the `*.aspx` file containing this control, the control responds by emitting into the output stream the following HTML declaration:

```
<input type="submit" name="btnMyButton" value="Button" id="btnMyButton"
  style="border-color:Blue;border-width:5px;border-style:Solid;" />
```

Notice how the web control emits back standard HTML that can be rendered in any browser. Given this, understand that using Web Forms controls in no way ties you to the Microsoft family of operating systems or to Microsoft Internet Explorer. Any operating system or browser (including those on handheld devices such as the Apple iPhone, Android, or Windows Phone devices) can view a Web Forms page.

Next, note from the previous list of features that a Web Forms application will be compiled into a .NET assembly. Thus, your web projects are no different than any .NET `*.dll` built during this book. The compiled web application will be composed of CIL code, an assembly manifest, and type metadata. This has a number of huge benefits, most notably performance gains, strong typing, and the ability to be micromanaged by the CLR (e.g., garbage collection, etc.).

Finally, Web Forms applications provide a programming model whereby you can partition your page's markup from its related C# code base using *code files*. Using code files, the markup you type will map to a full-blown object model that is merged with your C# code file via partial class declarations.

Major Features of Web Forms 2.0 and Higher

ASP.NET 1.0 was a major step in the right direction, and ASP.NET 2.0 provided many additional bells and whistles that helped ASP.NET move from a way to build dynamic *web pages* to a way to build feature-rich *web sites*. Consider this partial list of key features:

- Introduction of the ASP.NET Development Web Server (which means developers no longer need to have the full version of IIS installed on their development computers). This is now replaced by IIS Express.
- A large number of new web controls that handle many complex situations (navigation controls, security controls, new data-binding controls, etc.).

- The introduction of *master pages*, which allow developers to attach a common UI frame to a set of related pages.
- Support for *themes*, which offer a declarative manner to change the look and feel of the entire web application on the web server.
- Support for *Web Parts*, which allow end users to customize the look and feel of a web page and store their settings for later use (à la portals).
- Introduction of a web-based configuration and management utility that maintains the various `Web.config` files.

Beyond the ASP.NET Development Web Server, one of the biggest additions brought forth with ASP.NET 2.0 was the introduction of *master pages*. As you are aware, most web sites have a look and feel that is common to all pages on the site. Consider a commercial web site such as www.amazon.com. Every page has the same elements, such as a common header, common footer, common navigation menus, and so on.

Using a master page, you can model this common functionality and define *placeholders* that other *.aspx files can plug into. This makes it very easy to quickly reshape the overall look and feel of your site (reposition the navigation bar, change the header logo, and so on) by simply changing the master page, leaving the other *.aspx files unmodified.

■ **Note** Master pages are so useful that as of Visual Studio 2010, all new Web Forms web projects include a master page by default.

ASP.NET 2.0 also added many new web controls into the mix, including controls that automatically incorporate common security features (log in controls, password recovery controls, etc.), controls that allow you to layer a navigational structure on top of a set of related *.aspx files, and even more controls for performing complex data-binding operations, where the necessary SQL queries can be generated using a set of Web Forms controls.

Major Features of Web Forms 3.5 (and .NET 3.5 SP1) and Higher

Note that .NET 3.5 added the ability for Web Forms applications to make use of the LINQ programming model (also introduced in .NET 3.5) and the following web-centric features:

- Support for data binding against ADO.NET Entity Framework classes (see Chapter 23).
- Support for ASP.NET Dynamic Data. This is a Ruby on Rails–inspired web framework that can be used to build data-driven web applications. It exposes tables in a database by encoding them in the URI of the ASP.NET web service, and the data in the table is automatically rendered to HTML.
- Integrated support for Ajax-style development, which essentially allows for micro postbacks to refresh part of a web page as quickly as possible.

The ASP.NET Dynamic Data project templates, introduced with the .NET 3.5 Service Pack 1, provide a new model to build sites that are driven heavily by a relational database. Of course, most web sites will need to communicate with databases to some extent, but the ASP.NET Dynamic Data projects are tightly connected to the ADO.NET Entity Framework and are squarely focused on the rapid development of data-driven sites (similar to what one might build when using Ruby).

Major Features of Web Forms 4.0

.NET 4.0 added even more features to the Microsoft web development platform. Here is a hit list of some of the key web-centric features:

- The ability to compress “view state” data using the GZIP standard.
- JQuery is included with Web Forms and MVC.
- Updated browser definitions to ensure that ASP.NET pages render correctly on new browsers and devices (Google Chrome, Apple iPhone, Windows Phone, Android devices, etc.).
- The ability to customize the output of validation controls using a cascading style sheet (CSS).
- The inclusion of the ASP.NET Chart control, which allows for building ASP.NET pages that include intuitive charts for complex statistical or financial analysis.
- Support for ASP.NET Model View Controller project templates, which decrease the dependency among application layers by using the Model-View-Controller (MVC) pattern. This is a completely different approach to web site development and has little resemblance to the web form programming model examined in this edition of the text.

While this list is certainly impressive (and it’s only a subset of the new features), the work that Microsoft put into Web Forms for ASP.NET 4.5 brought many developers back to Web Forms from ASP.NET MVC (covered in Chapter 34).

Major Features of Web Forms 4.5 and 4.6

Two major focus areas of .NET 4.5 were performance improvements and porting many ASP.NET MVC features back into Web Forms. Here is just a partial list of all that was new in Web Forms 4.5 and Web Forms 4.6.

Features Added in Web Forms 4.5

- Numerous updates to support HTML 5.0.
- Integration with the new asynchronous language features of C# and VB.
- You can declare what type of data a control is going to be bound to by using a new `ItemType` property, allowing for strongly typed controls, IntelliSense support, and more.
- Model binding, which means you can map data from the page directly into method type parameters.
- Client-side validation is now integrated with JQuery, allowing for cleaner validation code.
- Additional validations available through Data Annotations, which are attributes on your model classes.
- Additional security from cross-site scripting attacks with the inclusion (by default) of the AntiXSS library.

- Reduced file sizes (for JavaScript and CSS) with minification (reducing files size by compressing the text of the files).
- Reduced number of browser calls by combining files into a single with bundling.
- You can defer request validation, allowing for posting of *potentially* unsafe content (use with caution).
- Applications can use more than one server code when compiling Web Forms applications.

Features Added in Web Forms 4.6

- Support for the new high speed HTTP2 protocol (currently only available for secure applications on IIS)
- Enabling new C# 6 features using the Roslyn Code DOM Compilers
- Ability to use async/await on model binding functions

As you might agree, the feature set of Web Forms is quite deep (and this API has many more features than I have briefly enumerated here). Truth be told, if I were to cover every possible feature of Web Forms, this book would easily double in size (triple, perhaps). Since this is not realistic, the goal for the remainder of the text is to examine the core features of Web Form that you will likely use on a day-to-day basis. Check out the .NET Framework 4.6 SDK documentation for features not covered here.

■ **Note** If you require a comprehensive treatment of building web applications using ASP.NET, I suggest picking up a copy of *Pro ASP.NET 4.5 in C#, Fifth Edition* by Adam Freeman and Matthew MacDonald (Apress).

Building a Single-File Web Forms Web App

A Web Forms page can be constructed using one of two primary approaches, the first of which is to build a single *.aspx file that contains a blend of server-side code and HTML. Using this *single-file page model* approach, the server-side code is placed within a <script> scope, but the code itself is *not* script code proper (e.g., VBScript/JavaScript). Rather, the code within a <script> block is written in your .NET language of choice (C#, Visual Basic, etc.).

If you are building a web page that contains very little code (but a good deal of static HTML), a single-file page model may be easier to work with because you can see the code and the markup in one unified *.aspx file. In addition, placing your procedural code and HTML markup into a single *.aspx file provides a few other advantages:

- Pages written using the single-file model are slightly easier to deploy or to send to another developer.
- Because there is no dependency between multiple files, a single-file page is easier to rename.
- Managing files in a source code control system is slightly easier because all the action takes place in a single file.

On the downside, the single-file page model can lead to some complex files because the UI markup and programming logic is isolated to one location. Nevertheless, you'll begin your journey of Web Forms by examining the single-file page model.

Your goal is to build an *.aspx file that displays the Inventory table of the AutoLot database (created in Chapter 21) using Entity Framework. To begin, launch Visual Studio and create a new empty ASP.NET web application named SinglePageModel. Select File ► New Project, then select Visual C#/Web from the left rail, and ASP.NET Web Application in the center pane, and enter SinglePageModel for the name, as in Figure 31-10.

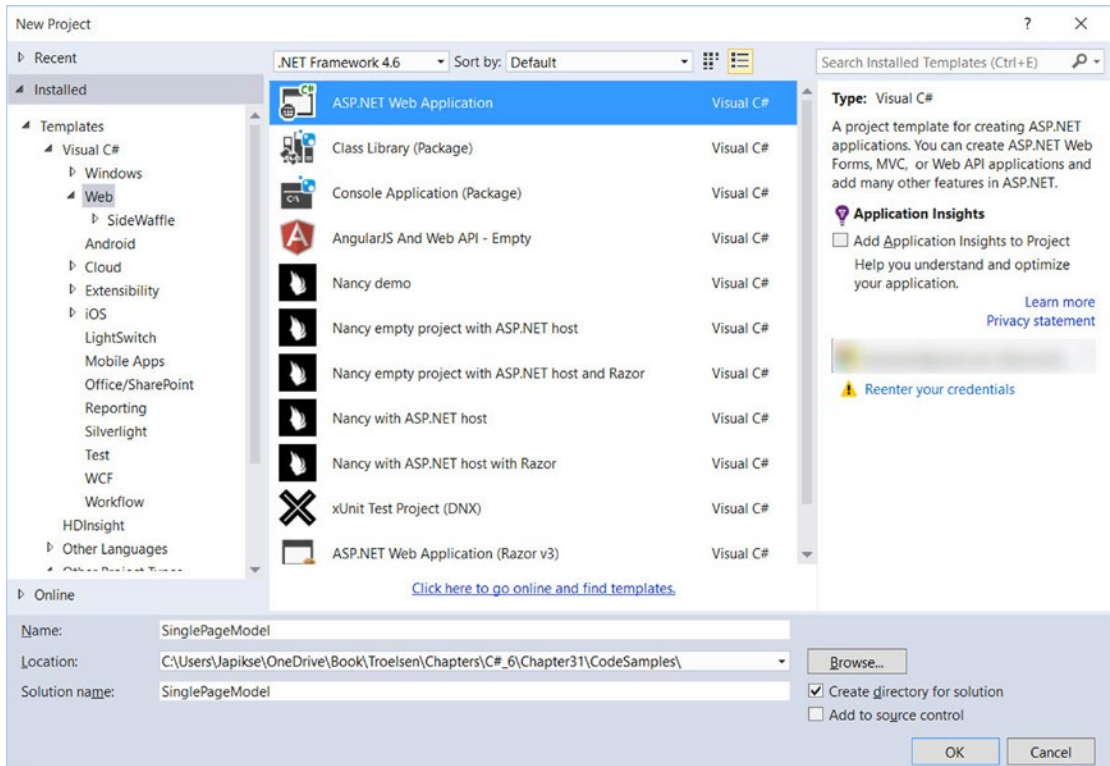

Figure 31-10. Select ASP.NET Web Application from the New Project dialog

After you click OK, you will see the updated New ASP.NET Project dialog. Make sure you select ASP.NET 4.6 templates, and the Empty project template. Leave the check boxes for Web Forms, MVC, and Web API under the “Add folders and core references for:” unchecked; leave the “Add unit tests” check box unchecked; and uncheck the Host in the cloud option (if it’s checked) under Microsoft Azure, as in Figure 31-11.

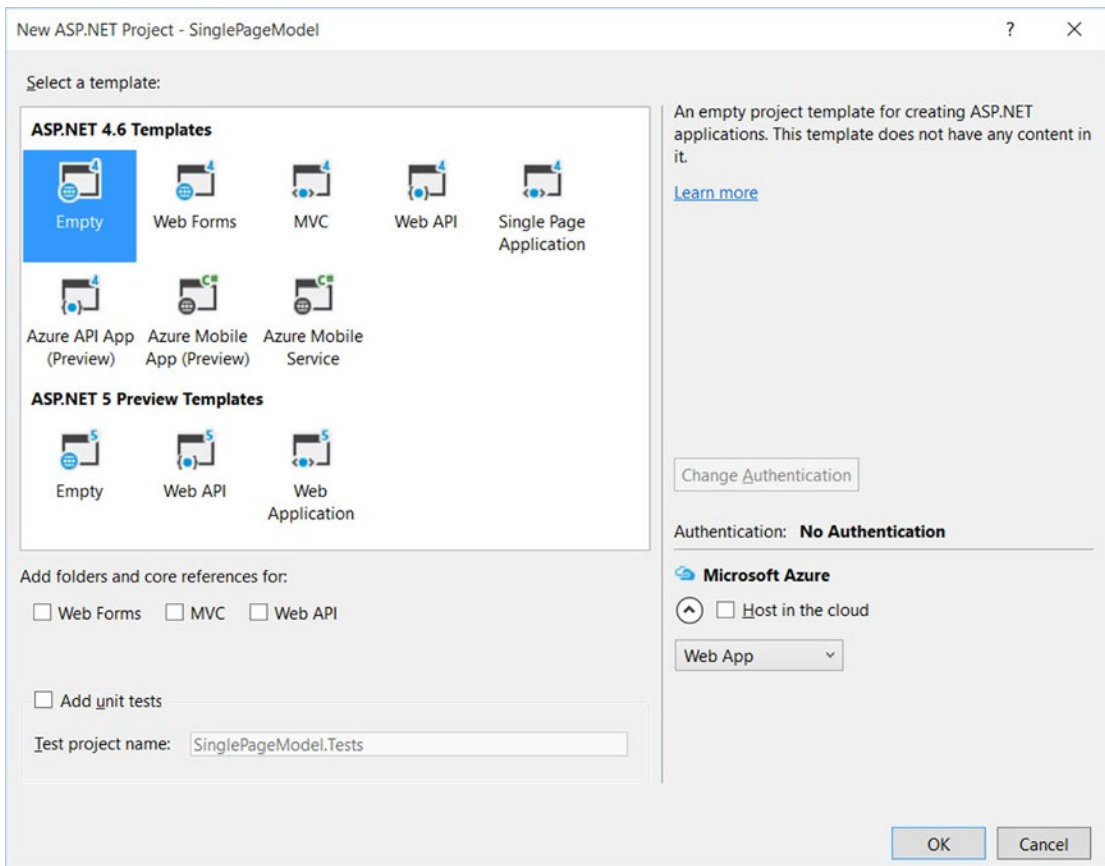

Figure 31-11. Choosing the empty project template

■ Note The .NET 4.6 Framework (which this book covers) is the current full version of the .NET Framework. ASP.NET 5 is built on .NET core, which is a subset of .NET 4.6. Note that .NET Core is for cross-platform web sites and only supports ASP.NET MVC and the Web API from a web development standpoint.

Next, add a new Web Form to the project by selecting Project ► Add New Item. Be sure to select Web ► Web Forms in the left rail. Name this file Default.aspx.

Referencing AutoLotDAL.dll

Next, use Windows Explorer to copy the AutoLotDAL directory from Chapter 23 (or from the download directory for this chapter). Add the project into the solution by right-clicking the solution and selecting Add ► Existing Project and choosing the AutoLotDAL project. Next, add a reference to the AutoLotDAL project by right-clicking the references node in the SinglePageModel project and selecting AutoLotDAL from the Projects/Solution option.

You will need to make a slight change to the AutoLotDAL project. First, add a reference to System.Web. The constructor for the DatabaseLogger doesn't specify a directory, which will cause the code to fail in a web site because of a lack of permissions. This has to be updated to point to the physical directory of the web site. In the System.Web namespace is a server variable called `HttpRequestuntime.AppDomainAppPath` that contains the physical directory of the web site. In the EF folder, open `AutoLotEntities.cs`, add a using for System.Web, and change the DatabaseLogger initializer to this:

```
static readonly DatabaseLogger DatabaseLogger =
    new DatabaseLogger($"{HttpRequestuntime.AppDomainAppPath}/sqllog.txt");
```

This change makes sure that the logging file is created in the same directory as the web site, resolving the permission issue.

Next, add Entity Framework to the web project by right-clicking the solution in Solution Explorer, selecting Manage NuGet Packages for Solution, and adding Entity Framework. You will also need to update the web.config file (this is analogous to the App.config files you have already been working with in previous chapters) to match the following (you might have to change your connection string based on the instance name for your SQL Server install):

```
<configuration>
  <configSections>
    <!-- For more information on Entity Framework configuration, visit
         http://go.microsoft.com/fwlink/?LinkID=237468 -->
    <section name="entityFramework"
      type="System.Data.Entity.Internal.ConfigFile.EntityFrameworkSection, EntityFramework,
      Version=6.0.0.0, Culture=neutral, PublicKeyToken=b77a5c561934e089"
      requirePermission="false"/>
  </configSections>
  <system.web>
    <compilation debug="true" targetFramework="4.6"/>
    <httpRuntime targetFramework="4.6"/>
  </system.web>
  <entityFramework>
    <defaultConnectionFactory type="System.Data.Entity.Infrastructure.
      LocalDbConnectionFactory, EntityFramework">
      <parameters>
        <parameter value="mssqllocaldb"/>
      </parameters>
    </defaultConnectionFactory>
    <providers>
      <provider invariantName="System.Data.SqlClient" type="System.Data.Entity.SqlServer.
        SqlProviderServices, EntityFramework.SqlServer"/>
    </providers>
  </entityFramework>
  <connectionStrings>
    <add name="AutoLotConnection"
      connectionString="data source=.\SQLEXPRESS2014;initial catalog=AutoLot;integrated
      security=True;MultipleActiveResultSets=True;App=EntityFramework"
      providerName="System.Data.SqlClient"/>
  </connectionStrings>
</configuration>
```

Designing the UI

Now, open `Default.aspx`, click the **Design** tab, and using the Visual Studio Toolbox, select the **Standard** tab and drag and drop a `GridView` control (the `GridView` widget can be found under the **Data** tab of the Toolbox) onto the page designer between the opening and closing form elements. Notice that the designer fills in random data into the `GridView` to give you a sense of how your page will look. Feel free to make use of the **Properties** window to set various visual property settings as you choose. Now, locate the `<form>` section of your page. Notice how the web control has been defined using an `<asp>` tag. After this tag prefix, you will find the name of a Web Forms control (`GridView`). Before the closing tag of a given element, you will find a series of name/value pairs that correspond to the settings available in the **Properties** window, like so:

```
<form id="form1" runat="server">
<div>
  <asp:GridView ID="carsGridView" runat="server">
  </asp:GridView>
</div>
</form>
```

You will dig into the full details of Web Forms controls (including `runat="server"`) later in [Chapter 32](#). Until then, recall that web controls are objects processed on the web server that emit back their HTML representation into the outgoing HTTP response automatically. Beyond this major benefit, Web Forms controls mimic a desktop-like programming model in that the names of the properties, methods, and events typically mimic an equivalent Windows Forms/WPF counterpart.

Adding the Data Access Logic

Now, switch to the source, and add an `ItemType` attribute to the `asp:GridView` tag with the value `"AutoLotDAL.Models.Inventory"`. This new feature, introduced in .NET 4.5, provides for strongly typed list controls in ASP.NET Web Forms, and is supported by IntelliSense to recognize the classes available in the solution.

Next, add a `SelectMethod` attribute with the value `"GetData"`. The `SelectMethod` attribute was also introduced in .NET 4.5, and sets the method that will be executed when the control is rendered to get the data that will populate the list control. The updated markup is shown here:

```
<asp:GridView ID="carsGridView" runat="server"
  ItemType="AutoLotDAL.Models.Inventory"
  SelectMethod="GetData" >
</asp:GridView>
```

Create the `GetData` method in a `<script>` tag within the page. In the method, call the `InventoryRepo.GetAll` method. Use the `<%@ Import ... %>` to import `AutoLotDAL.Models` and `AutoLotDAL.Repos`. Your code should be similar to this:

```
<!--At the top of the file, after the Page directive -->
<%@ Import Namespace="AutoLotDAL.Models" %>
<%@ Import Namespace="AutoLotDAL.Repos" %>
```

```

<!--Anywhere in the file, before the GridView control -->
<script runat="server">
    public IEnumerable<Inventory> GetData()
    {
        return new InventoryRepo().GetAll();
    }
</script>

```

■ **Note** You only need to use the `<%@ Import %>` directive if you are building a page with the single-file code model. If you are using the default code file approach, use the `using` keyword of C# to include namespaces in your code file. The same is true for the `<%@ Assembly %>` directive, described next.

Before you dive into the details behind the format of this *.aspx file, let's try a test run. First, save your *.aspx file. Click Run or press F5, which will launch IIS Express, which hosts your page.

When the page is served, the `Select` method is executed, loading the data into the `GridView`. Figure 31-12 shows the output.



The screenshot shows a web browser interface with a navigation bar containing back, forward, and refresh buttons, and the address bar displaying 'localhost:22542/Default.aspx'. Below the browser is a table with 8 rows and 4 columns: CarId, Make, Color, and PetName. The data in the table is as follows:

| CarId | Make | Color | PetName |
|-------|-------|--------|---------|
| 1 | VW | Black | Zippy |
| 2 | Ford | Rust | Rusty |
| 3 | Saab | Black | Mel |
| 4 | Yugo | Yellow | Clunker |
| 5 | BMW | Black | Bimmer |
| 6 | BMW | Green | Hank |
| 7 | BMW | Pink | Pinky |
| 13 | Pinto | Black | Pete |

Figure 31-12. ASP.NET provides a declarative data-binding model

Given, the current UI is quite bland. To spice up the current example, select the `GridView` control on the Visual Studio designer, and using the context menu (that tiny arrow on the upper right of the control), select the `Auto Format` option (see Figure 31-13).

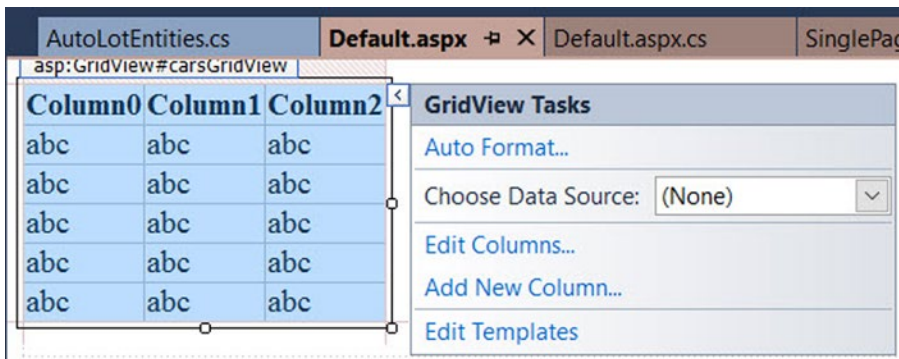

Figure 31-13. Configuring the ASP.NET GridView control

From the resulting dialog box, pick a template that suits your fancy (I picked “Slate”). After you click OK, view the generated control declaration, which is quite a bit richer than before.

```
<asp:GridView ID="carsGridView" runat="server"
  ItemType="AutoLotDAL.Models.Inventory"
  SelectMethod="GetData" BackColor="White" BorderColor="#E7E7FF"
  BorderStyle="None" BorderWidth="1px" CellPadding="3" GridLines="Horizontal" >
  <AlternatingRowStyle BackColor="#F7F7F7" />
  <FooterStyle BackColor="#B5C7DE" ForeColor="#4A3C8C" />
  <HeaderStyle BackColor="#4A3C8C" Font-Bold="True" ForeColor="#F7F7F7" />
  <PagerStyle BackColor="#E7E7FF" ForeColor="#4A3C8C" HorizontalAlign="Right" />
  <RowStyle BackColor="#E7E7FF" ForeColor="#4A3C8C" />
  <SelectedRowStyle BackColor="#738A9C" Font-Bold="True" ForeColor="#F7F7F7" />
  <SortedAscendingCellStyle BackColor="#F4F4FD" />
  <SortedAscendingHeaderStyle BackColor="#5A4C9D" />
  <SortedDescendingCellStyle BackColor="#D8D8F0" />
  <SortedDescendingHeaderStyle BackColor="#3E3277" />
</asp:GridView>
```

If you view your application again and click your button, you will now see a more interesting UI (see Figure 31-14).



| CarId | Make | Color | PetName |
|-------|-------|--------|---------|
| 1 | VW | Black | Zippy |
| 2 | Ford | Rust | Rusty |
| 3 | Saab | Black | Mel |
| 4 | Yugo | Yellow | Clunker |
| 5 | BMW | Black | Bimmer |
| 6 | BMW | Green | Hank |
| 7 | BMW | Pink | Pinky |
| 13 | Pinto | Black | Pete |

Figure 31-14. A richer display for your test page

That was fairly simple, yes? Of course, as they say, the devil is in the details, so let's dig a bit deeper into the composition of this *.aspx file, beginning with examining the role of the `<%@Page... %>` directive. Do be aware that the topics you examine will apply directly to the more preferred *code file* model examined next.

The Role of ASP.NET Directives

A given *.aspx file will typically open with a set of *directives*. ASP.NET directives are always denoted with `<%@ ... %>` markers and may be qualified with various attributes to inform the ASP.NET runtime how to process the attribute in question.

Every *.aspx file will have at minimum a `<%@Page%>` directive that is used to define the managed language used within the page (via the `language` attribute). Also, the `<%@Page%>` directive may define the name of the related code-behind file (examined soon), and so on. Table 31-1 documents some of the more interesting `<%@Page%>`-centric attributes.

Table 31-1. Select Attributes of the `<%@Page%>` Directive

| Attribute | Meaning in Life |
|-----------------|---|
| CodePage | Specifies the name of the related code-behind file |
| EnableTheming | Establishes whether the controls on the *.aspx page support ASP.NET themes |
| EnableViewState | Indicates whether view state is maintained across page requests (more details on this property in Chapter 33) |
| Inherits | Defines a class in the code-behind page the *.aspx file derives from, which can be any class derived from <code>System.Web.UI.Page</code> |
| MasterPageFile | Sets the master page used in conjunction with the current *.aspx page |
| Trace | Indicates whether tracing is enabled |

In addition to the `<%@Page%>` directive, a given `*.aspx` file may specify various `<%@Import%>` directives to explicitly state the namespaces required by the current page and `<%@Assembly%>` directives to specify the external code libraries used by the site (typically placed in the `\bin` folder of the web site).

In this example, you specified the types within the `Models` and `Repos` namespaces within the `AutoLotDAL.dll` assembly. If you need to make use of additional .NET namespaces, you simply specify multiple `<%@Import%>/<%@Assembly%>` directives.

To be sure, ASP.NET does define a number of other directives that may appear in an `*.aspx` file above and beyond `<%@Page%>`, `<%@Import%>`, and `<%@Assembly%>`; however, I'll reserve commenting on those for the time being. You'll see examples of other directives as you progress through the remaining chapters.

Analyzing the “Script” Block

Under the single-file page model, an `*.aspx` file may contain server-side scripting logic that executes on the web server. In this case, it is *critical* that all of your server-side code blocks are defined to execute at the server, using the `runat="server"` attribute. If the `runat="server"` attribute is not supplied, the runtime assumes you have authored a block of *client-side* script to be emitted into the outgoing HTTP response, and it will throw an exception. That being said, here is a proper server-side `<script>` block:

```
<script runat="server">
    public IEnumerable<Inventory> GetData()
    {
        return new InventoryRepo().GetAll();
    }
</script>
```

■ **Note** All Web Forms controls need to have the `runat="server"` attribute in their opening declaration. If not, they will not render their HTML into the outbound HTTP response.

Analyzing the ASP.NET Control Declarations

The final point of interest in this first example is the declaration of the `GridView` web control. Like classic ASP and raw HTML, Web Forms widgets are scoped within `<form>` elements. This time, however, the opening `<form>` element is marked with the `runat="server"` attribute. As well, the controls are qualified with the `asp:` tag prefix. Any control that takes this prefix is a member of the ASP.NET control library and has a corresponding C# class representation in a given .NET namespace of the .NET base class libraries. Here you find

```
<form id="form1" runat="server">
    <div>
        <asp:GridView ID="carsGridView" runat="server"
            ItemType="AutoLotDAL.Models.Inventory"
            SelectMethod="GetData" >
        </asp:GridView>
    </div>
</form>
```

The `System.Web.UI.WebControls` namespace of the `System.Web.dll` assembly contains a majority of the Web Forms controls. If you were to open the Visual Studio Object Browser, you could, for example, locate the `DataGrid` control (see Figure 31-15).

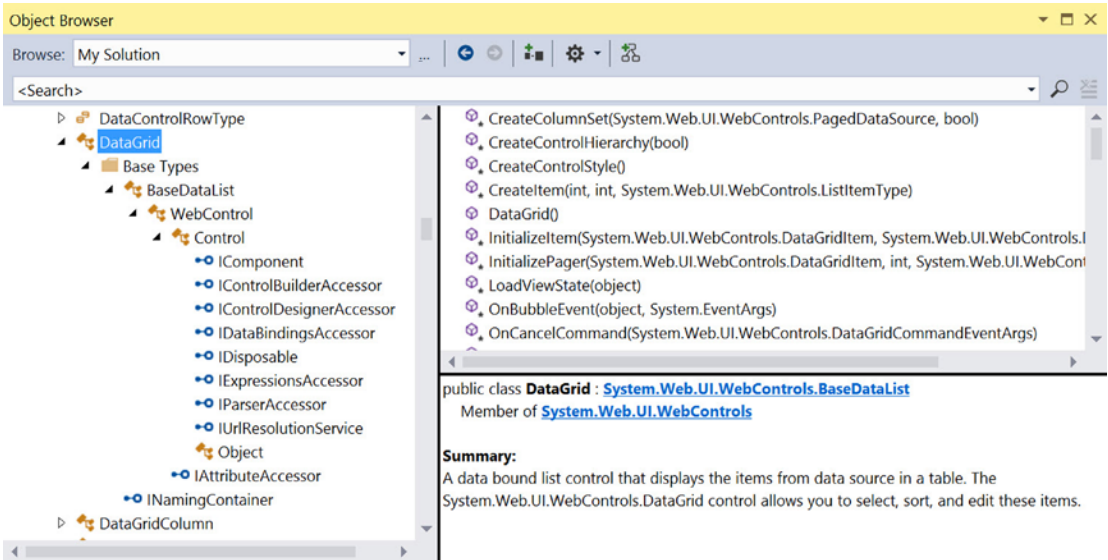

Figure 31-15. All ASP.NET control declarations map to a .NET class type

As you can see, a Web Forms control has an inheritance chain with `System.Object` at the very top. The `WebControl` parent class is a common base to all ASP.NET controls and defines all the common UI properties you would expect (`BackColor`, `Height`, etc.). The `Control` class is also very common within the framework; however, it defines more infrastructure-centric members (data binding, view state, etc.) rather than a child's graphical look and feel. You'll learn more about these classes in Chapter 33.

■ **Source Code** The `SinglePageModel` web site is included in the Chapter 31 subdirectory.

Building an ASP.NET Web Page Using Code Files

While the single-file code model can be helpful at times, the default approach taken by Visual Studio (when creating a new web project) is to make use of a technique known as *code-behind*, which allows you to separate your server-side programming code from your HTML presentation logic using two distinct files. This model works quite well when your pages contain a significant amount of code or when multiple developers are working on the same web site. The code-behind model offers other benefits as well, such as the following:

- Because code-behind pages offer a clean separation of HTML markup and code, it is possible to have designers working on the markup while programmers author the C# code.
- Code is not exposed to page designers or others who are working only with the page markup (as you might guess, HTML folks are not always interested in viewing reams of C# code).
- Code files can be used across multiple *.aspx files.

Regardless of which approach you take, there is *no* difference in terms of performance. In fact, many Web Forms applications benefit from building sites that make use of both approaches. To illustrate the code-behind page model, let's recreate the previous example once again using a blank Visual Studio web site template. Activate the File ► New ► Project menu option, then select ASP.NET Web Application and then the Empty ASP.NET 4.6 Template.

Now, using the Project ► Add New Item menu option, insert a new Web Form item named `Default.aspx`. Once again, make use of the designer to build a UI consisting of a single `GridView`, and make use of the Properties window to build a UI of your liking. If you like you can copy the previous ASP.NET control declarations from the `SinglePageModel` example directly into your new `*.aspx` file. Given that this is the exact same markup, I won't bother to relist it here (just be sure to paste the control declarations between the `<form>` and `</form>` tags).

Now, notice that the `<%@Page%>` directive used within the code file model has a few attributes:

```
<%@ Page Language="C#" AutoEventWireup="true"
    CodeBehind="Default.aspx.cs" Inherits="CodeBehindPageModel.Default" %>
```

The `CodeFile` attribute is used to specify the related external file that contains this page's coding logic. By default, these code-behind files are named by adding the suffix `.cs` to the name of the `*.aspx` file (`Default.aspx.cs`, in this example). If you examine Solution Explorer, you will see this code-behind file is visible via a subnode on the Web Form icon (see Figure 31-16).

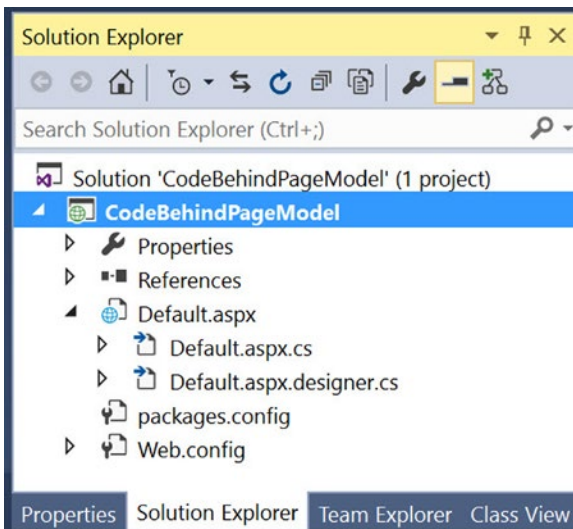

Figure 31-16. The associated code-behind file for a given `*.aspx` file

If you were to open your code-behind file, you would find a partial class deriving from `System.Web.UI.Page` with support for handling the `Load` event. Notice that the fully qualified name of this class (`CodeBehindPageModel.Default`) is identical to the `Inherits` attribute within the `<%@Page%>` directive.

```
public partial class Default : System.Web.UI.Page
{
    protected void Page_Load(object sender, EventArgs e)
    {
    }
}
```

Reference the AutoLotDAL Project

You will need the updated AutoLotDAL project (or the compiled AutoLotDAL.dll) from the previous exercise. If you add the AutoLotDAL project to your solution, you will need to add a reference from your web project to AutoLotDAL. If you are going to reference the compiled AutoLotDAL.dll assembly, you need to add the file to the `\bin` folder within Solution Explorer, as shown in Figure 31-17 (you might need to toggle the Show All Files button).

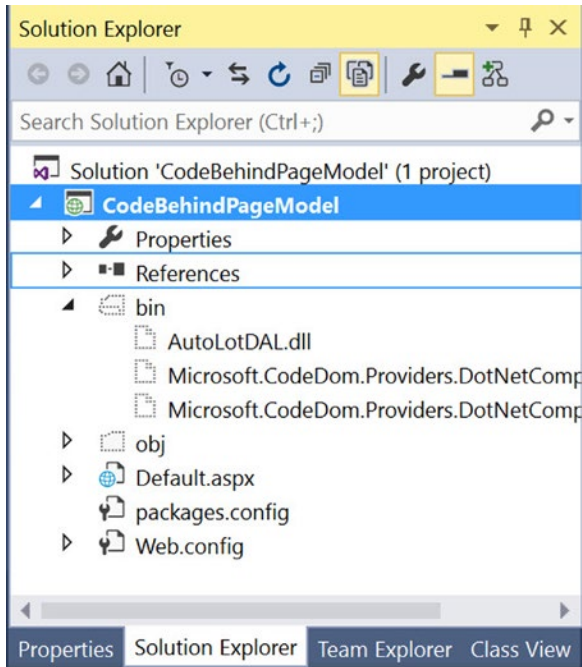

Figure 31-17. Visual Studio web projects make use of special ASP.NET folders

Just like in the previous example, add the Entity Framework to the web project by right-clicking the project, selecting Manage NuGet Packages, and installing EF. Finally, copy the `<connectionStrings>` node into the `Web.config` file.

Updating the Code File

If you examine the `Default.aspx` file in the previous example, you'll see that each Web Forms page is composed of three files: the `*.aspx` file (for markup), the `*.designer.cs` file (for designer-generated C# code), and the primary C# code file (for your event handlers, custom methods, and whatnot). See Figure 31-18.

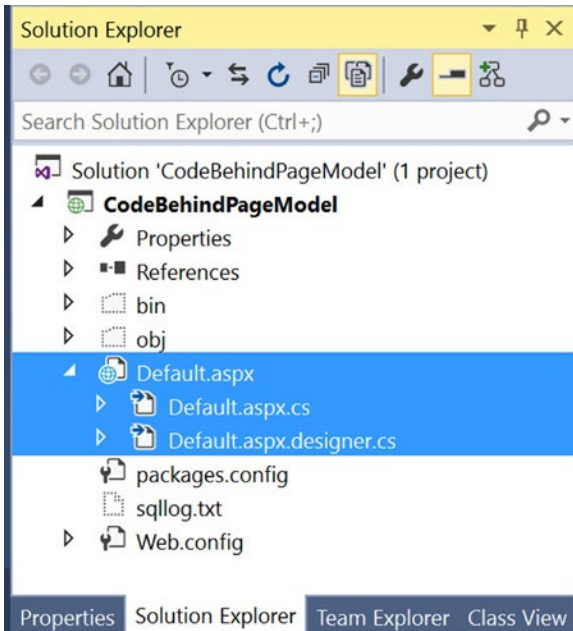

Figure 31-18. Under the Web Application model, each web page is composed of three files

If you copied the markup from the previous example, all you need to do now is create the `GetData` method in the `Default.aspx.cs` code-behind file. Start by adding `using` statements for `AutoLotDAL.Models` and `AutoLotDAL.Repos`. Then, add the `GetData` method as follows:

```
using AutoLotDAL.Models;
using AutoLotDAL.Repos;

namespace CodeBehindPageModel
{
    public partial class Default : System.Web.UI.Page
    {
        protected void Page_Load(object sender, EventArgs e)
        {
        }
        public IEnumerable<Inventory> GetData()
        {
            return new InventoryRepo().GetAll();
        }
    }
}
```

At this point, you can run your web application by pressing the `Ctrl+F5` (or `F5`) key combination. Once again, IIS Express will fire up, serving your page into your hosting browser.

Debugging and Tracing ASP.NET Pages

To debug your Web Forms applications, your site must contain a properly configured `Web.config` file. When you start a debugging session, if the IDE asks if you would like to modify the `Web.config` file to enable debugging, answer yes. It means that your `Web.config` was missing the following markup (the most important being the `debug="true"` attribute):

```
<compilation debug="true" targetFramework="4.6"/>
```

On a related note, you can enable *tracing support* for an `*.aspx` file by setting the `Trace` attribute to true within the `<%@Page%>` directive (it is also possible to enable tracing for your entire site by modifying the `Web.config` file).

```
<%@ Page Language="C#" AutoEventWireup="true"
    CodeBehind="Default.aspx.cs" Inherits="CodeBehindPageModel.Default"
    Trace="true" %>
```

■ **Note** Web application pages inherit from the fully qualified name of the class, in this case `CodeBehindPageModel.Default`. Web site pages inherit from the name of the page preceded with an underscore, such as `_Default`.

Once you do so, the emitted HTML contains numerous details regarding the previous HTTP request/response (server variables, session and application variables, request/response, etc.). To insert your own trace messages into the mix, you can use the `Trace` property inherited from `System.Web.UI.Page`. Anytime you would like to log a custom message (from a script block or C# source code file), simply call the static `Trace.Write()` method. The first argument represents the name of your custom category; the second argument specifies the trace message. To illustrate, update the `GetData` method with the following code statement:

```
public IEnumerable<Inventory> GetData()
{
    Trace.Write("Default.aspx", "Getting Data");
    return new InventoryRepo().GetAll();
}
```

Run your project once again. You will find your custom category and custom message are present and accounted for. In Figure 31-19, take note of the highlighted message that displays the trace information.

| Trace Information | | | |
|-------------------|-------------------------|---------------|--------------|
| Category | Message | From First(s) | From Last(s) |
| aspx.page | Begin PreInit | | |
| aspx.page | End PreInit | 0.000054 | 0.000054 |
| aspx.page | Begin Init | 0.000083 | 0.000029 |
| aspx.page | End Init | 0.035438 | 0.035356 |
| aspx.page | Begin InitComplete | 0.035471 | 0.000032 |
| aspx.page | End InitComplete | 0.035483 | 0.000012 |
| aspx.page | Begin PreLoad | 0.035494 | 0.000011 |
| aspx.page | End PreLoad | 0.035515 | 0.000021 |
| aspx.page | Begin Load | 0.035525 | 0.000010 |
| aspx.page | End Load | 0.035875 | 0.000350 |
| aspx.page | Begin LoadComplete | 0.035890 | 0.000015 |
| aspx.page | End LoadComplete | 0.041524 | 0.005634 |
| aspx.page | Begin PreRender | 0.041583 | 0.000059 |
| Default.aspx | Getting Data | 0.071696 | 0.030112 |
| aspx.page | End PreRender | 0.732762 | 0.661067 |
| aspx.page | Begin PreRenderComplete | 0.732802 | 0.000040 |
| aspx.page | End PreRenderComplete | 0.732812 | 0.000010 |
| aspx.page | Begin SaveState | 0.735502 | 0.002690 |
| aspx.page | End SaveState | 0.748051 | 0.012549 |
| aspx.page | Begin SaveStateComplete | 0.748073 | 0.000022 |
| aspx.page | End SaveStateComplete | 0.821923 | 0.073850 |
| aspx.page | Begin Render | 0.821966 | 0.000043 |
| aspx.page | End Render | 0.826076 | 0.004110 |

Figure 31-19. Logging custom trace messages

You now know how to build a single Web Forms page using the single-file and code file approach. The rest of this chapter will take a deeper look into the composition of a Web Forms project, as well as ways to interact with the HTTP request/response and the life cycle of a Page-derived class.

■ **Source Code** The CodeBehindPageModel web site is included in the Chapter 31 subdirectory.

ASP.NET Web Sites vs. ASP.NET Web Applications

When you are about to build a new Web Forms project, you need to make a choice regarding which of the two project formats you will make use of, an *ASP.NET web site* or an *ASP.NET web application*. Your choice of web project will control the way in which Visual Studio organizes and processes your web application starter files, the type of initial project files that are created, and how much control you have over the resulting composition of the compiled .NET assembly.

When ASP.NET was first released with .NET 1.0, the only option was to build what is now termed a *web application*. Under this model, you have direct control over the name and location of the compiled output assembly.

Web applications are useful when you are migrating older .NET 1.1 web sites into .NET 2.0 and higher projects. Web applications are also helpful when you want to build a single Visual Studio Solution that can contain multiple projects (for example, the web application and any related .NET code libraries). The previous two examples used ASP.NET web applications as the starting point.

■ **Note** Because the Visual Studio ASP.NET project templates can generate a great deal of starter code (master pages, content pages, script libraries, a login page, etc.), this book will opt to use the Blank web site template. However, after you have read the ASP.NET chapters of this text, make sure you create a new ASP.NET web site project and examine this starter code first hand.

In stark contrast, the Visual Studio ASP.NET web site project templates (found under the File ► New Web Site menu option) hide the *.designer.cs file in favor of an in-memory partial class. Moreover, ASP.NET web site projects support a number of specially named folders, such as App_Code. Within this folder, you can place any C# (or VB) code files that are not directly mapped to your web pages, and the runtime compiler will dynamically compile them as required. This is a great simplification to the normal act of building a dedicated .NET code library and referencing it in new projects.

On a related note, a web site project can be pushed as-is to a production web server without the need to precompile the site, as you would need to do with an ASP.NET web application.

In this book, we'll make use of ASP.NET web site project types because they do offer some simplifications to the process of building web applications under the .NET platform. However, regardless of which approach you take, you will have access to the same overall programming model.

Enabling C# 6 For ASP.NET Web Sites

By default, ASP.NET web sites don't have C# 6 enabled (Web Forms projects have C# enabled in the default project template). To enable the new C# 6 language features, you have to install the CodeDom Providers NuGet package. To install this for web sites, right-click the web site name in Solution Explorer, select Manage NuGet Packages, and search for CodeDom. This will bring up Microsoft.CodeDom.Providers.DotNetCompilerPlatform. Click Install.

The ASP.NET Web Site Directory Structure

When you create a new ASP.NET web site project, your project may contain any number of specifically named subdirectories, each of which has a special meaning to the ASP.NET runtime. Table 31-2 documents these special subdirectories.

Table 31-2. *Special ASP.NET Subdirectories*

| Subfolder | Meaning in Life |
|---------------------|--|
| App_Browsers | Folder for browser definition files that are used to identify individual browsers and determine their capabilities. |
| App_Code | Folder for source code for components or classes that you want to compile as part of your application. ASP.NET compiles the code in this folder when pages are requested. Code in the App_Code folder is automatically accessible by your application. |
| App_Data | Folder for storing Access *.mdb files, SQL Express *.mdf files, XML files, or other data stores. |
| App_GlobalResources | Folder for *.resx files that are accessed programmatically from application code. |
| App_LocalResources | Folder for *.resx files that are bound to a specific page. |
| App_Themes | Folder that contains a collection of files that define the appearance of Web Forms pages and controls. |
| App_WebReferences | Folder for proxy classes, schemas, and other files associated with using a web service in your application. |
| Bin | Folder for compiled private assemblies (*.dll files). Assemblies in the Bin folder are automatically referenced by your application. |

If you are interested in adding any of these known subfolders to your current web application, you may do so explicitly using the Website ► Add ASP.NET Folder menu option. However, in many cases, the IDE will automatically do so as you naturally insert related files into your site. For example, inserting a new class file into your project will automatically add an App_Code folder to your directory structure if one does not currently exist.

Referencing Assemblies

Although the web site templates do generate an *.sln file to load your *.aspx files into the IDE, there is no longer a related *.csproj file. However, an ASP.NET web application project records all external assemblies within *.csproj. So where are the external assemblies recorded under ASP.NET?

As you have seen, when you reference a private assembly, Visual Studio will automatically create a \bin directory within your directory structure to store a local copy of the binary. When your code base makes use of types within these code libraries, they are automatically loaded on demand.

If you reference a shared assembly located in the Global Assembly Cache, Visual Studio will automatically insert a Web.config file into your current web solution (if one is not currently in place) and record the external reference within the <assemblies> element. For example, if you again activate the Website ► Add Reference menu option and this time select a shared assembly (such as System.Security.dll), you will find that your Web.config file has been updated as follows:

```
<assemblies>
  <add assembly="System.Security, Version=4.0.0.0,
    Culture=neutral, PublicKeyToken=B03F5F7F11D50A3A"/>
</assemblies>
```

As you can see, each assembly is described using the same information required for a dynamic load via the `Assembly.Load()` method (see Chapter 15).

The Role of the App_Code Folder

The `App_Code` folder is used to store source code files that are not directly tied to a specific web page (such as a code-behind file) but are to be compiled for use by your web site. Code within the `App_Code` folder will be automatically compiled on the fly on an as-needed basis. After this point, the assembly is accessible to any other code in the web site. To this end, the `App_Code` folder is much like the `Bin` folder, except that you can store source code in it instead of compiled code. The major benefit of this approach is that it is possible to define custom types for your web application without having to compile them independently.

A single `App_Code` folder can contain code files from multiple languages. At runtime, the appropriate compiler kicks in to generate the assembly in question. If you would rather partition your code, however, you can define multiple subdirectories that are used to hold any number of managed code files (*.vb, *.cs, etc.).

For example, assume you have added an `App_Code` folder to the root directory of a web site application that has two subfolders, `MyCSharpCode` and `MyVbNetCode`, which contain language-specific files. After you have done so, you can update your `Web.config` file to specify these subdirectories using a `<codeSubDirectories>` element nested within the `<configuration>` element, like so:

```
<compilation debug="true" strict="false" explicit="true">
  <codeSubDirectories>
    <add directoryName="MyCSharpCode" />
    <add directoryName="MyVbNetCode" />
  </codeSubDirectories>
</compilation>
```

■ **Note** The `App_Code` directory will also be used to contain files that are not language files but are useful nonetheless (*.xsd files, *.wsdl files, etc.).

Beyond `Bin` and `App_Code`, the `App_Data` and `App_Themes` folders are two additional special subdirectories that you should be familiar with, both of which will be detailed in the next several chapters. As always, consult the .NET Framework 4.6 SDK documentation for full details on the remaining ASP.NET subdirectories if you require further information.

The Inheritance Chain of the Page Type

All .NET web pages eventually derive from `System.Web.UI.Page`. Like any base class, this type provides a polymorphic interface to all derived types. However, the `Page` type is not the only member in your inheritance hierarchy. If you were to locate the `System.Web.UI.Page` class (within the `System.Web.dll` assembly) using the Visual Studio object browser, you would find that `Page` is-a `TemplateControl` which is-a `Control`, which is-an `Object` (see Figure 31-20).

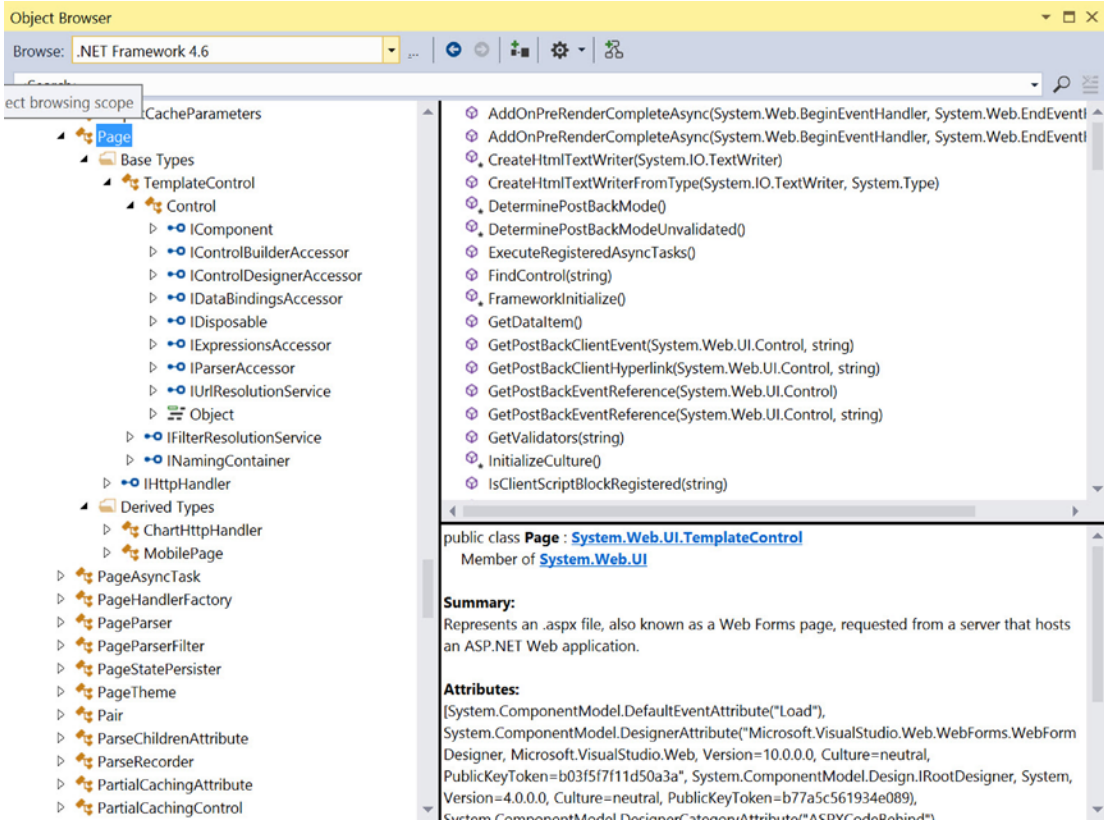

Figure 31-20. The inheritance chain of Page

Each of these base classes brings a good deal of functionality to each and every *.aspx file. For the majority of your projects, you will make use of the members defined within the `Page` and `Control` parent classes. The functionality gained from the `System.Web.UI.TemplateControl` class is only of interest if you are building custom Web Form controls or interacting with the rendering process.

The first parent class of interest is `Page` itself. Here you will find numerous properties that enable you to interact with various web primitives such as application and session variables, the HTTP request/response support, and so forth. Table 31-3 describes some (but by no means all) of the core properties.

Table 31-3. *Select Properties of the Page Type*

| Property | Meaning in Life |
|----------------|---|
| Application | Allows you to interact with data that can be accessed across the entire web site for all users |
| Cache | Allows you to interact with the cache object for the current web site |
| ClientTarget | Allows you to specify how this page should render itself based on the requesting browser |
| IsPostBack | Gets a value indicating whether the page is being loaded in response to a client postback or whether it is being loaded and accessed for the first time |
| MasterPageFile | Establishes the master page for the current page |
| Request | Provides access to the current HTTP request |
| Response | Allows you to interact with the outgoing HTTP response |
| Server | Provides access to the <code>HttpServerUtility</code> object, which contains various server-side helper functions |
| Session | Allows you to interact with the session data for the current caller |
| Theme | Gets or sets the name of the theme used for the current page |
| Trace | Provides access to a <code>TraceContext</code> object, which allows you to log custom messages during debugging sessions |

Interacting with the Incoming HTTP Request

As you saw earlier in this chapter, the basic flow of a web application begins with a client requesting a web page, possibly filling in user information, and clicking a “Submit button” to post back the HTML form data to a given web page for processing. In most cases, the opening tag of the `form` statement specifies an `action` attribute and a `method` attribute that indicates the file on the web server that will be sent the data in the various HTML widgets, as well as the method of sending this data (GET or POST).

```
<form name="defaultPage" id="defaultPage"
      action="http://localhost/Cars/ClassicAspPage.asp" method = "GET">
  ...
</form>
```

All ASP.NET pages support the `System.Web.UI.Page.Request` property, which provides access to an instance of the `HttpRequest` class type (see Table 31-4 for some common members of this class).

Table 31-4. *Members of the HttpRequest Class*

| Member | Meaning in Life |
|--------------------|--|
| ApplicationPath | Gets the ASP.NET application's virtual application root path on the server |
| Browser | Provides information about the capabilities of the client browser |
| Cookies | Gets a collection of cookies sent by the client browser |
| FilePath | Indicates the virtual path of the current request |
| Form | Gets a collection of HTTP form variables |
| Headers | Gets a collection of HTTP headers |
| HttpMethod | Indicates the HTTP data transfer method used by the client (GET, POST) |
| IsSecureConnection | Indicates whether the HTTP connection is secure (i.e., HTTPS) |
| QueryString | Gets the collection of HTTP query string variables |
| RawUrl | Gets the current request's raw URL |
| RequestType | Indicates the HTTP data transfer method used by the client (GET, POST) |
| ServerVariables | Gets a collection of web server variables |
| UserHostAddress | Gets the IP host address of the remote client |
| UserHostName | Gets the DNS name of the remote client |

In addition to these properties, the `HttpRequest` type has a number of useful methods, including the following:

- `MapPath()`: Maps the virtual path in the requested URL to a physical path on the server for the current request.
- `SaveAs`: Saves details of the current HTTP request to a file on the web server, which can prove helpful for debugging purposes.
- `ValidateInput()`: If the validation feature is enabled via the `Validate` attribute of the `Page` directive, this method can be called to check all user input data (including cookie data) against a predefined list of potentially dangerous input data.

Obtaining Browser Statistics

The first interesting aspect of the `HttpRequest` type is the `Browser` property, which provides access to an underlying `HttpBrowserCapabilities` object. `HttpBrowserCapabilities`, in turn, exposes numerous members that allow you to programmatically investigate statistics regarding the browser that sent the incoming HTTP request.

Create a new ASP.NET empty web site (named `FunWithPageMembers`) by selecting the `File` ► `New Web Site` menu option. You will see a screen similar to Figure 31-21.

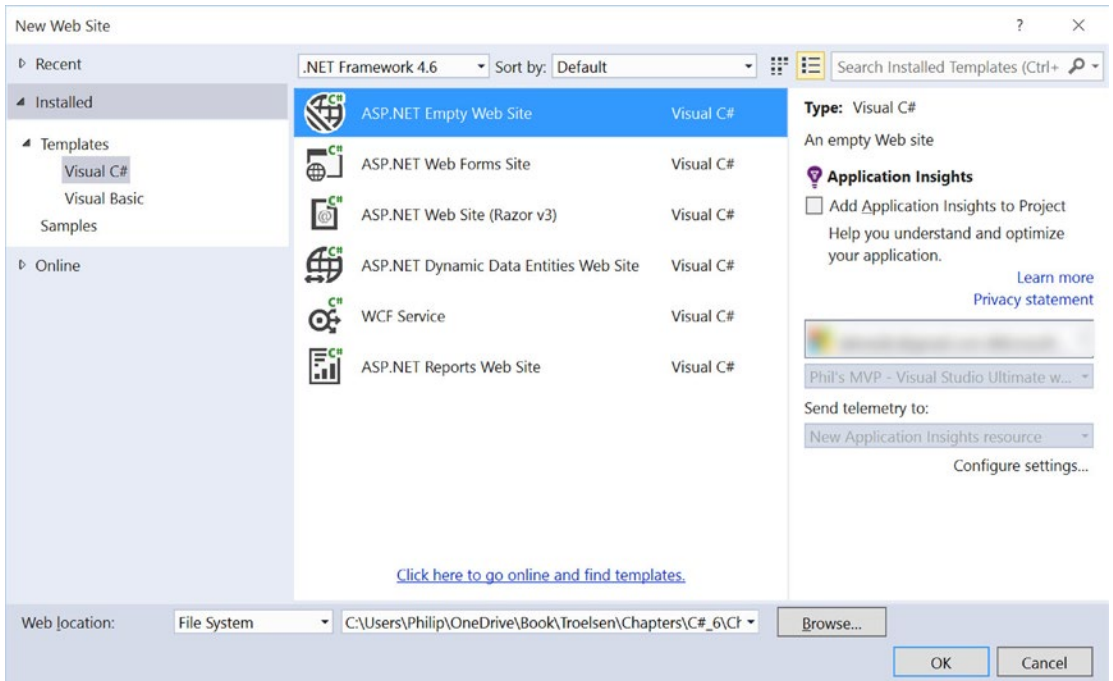

Figure 31-21. Creating a new, blank web site

Notice in Figure 31-21 that you are able to select the location of your new site. If you select File System, your content files will be placed within a local directory and pages will be served via IIS Express. If you select FTP or HTTP, your site will be hosted within a new virtual directory maintained by IIS. For this example, it makes no difference which option you select, but for simplicity I suggest selecting the File System option.

If you select a directory that already has a web site in it (or any files, for that matter), you will be prompted to enter a new name (which creates a new directory) via the dialog shown in Figure 31-22.

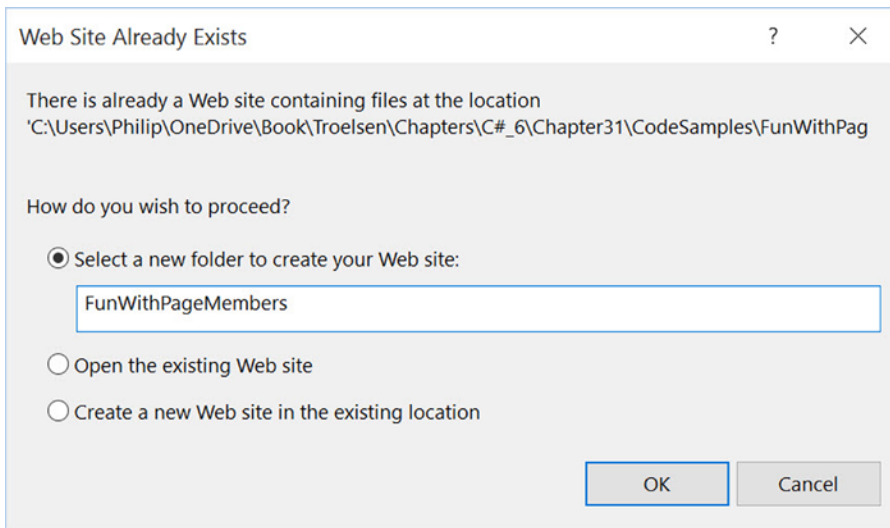

Figure 31-22. Specifying the name for the new, blank web site

Once you have your site set up, insert a new Web Forms file into your project using the Website ► Add New Item menu option. Select Visual C# in the left rail, and name the file `Default.aspx`. Your first task is to build a UI that allows users to click a Button web control (named `btnGetBrowserStats`) to view various statistics about the calling browser. These statistics will be generated dynamically and attached to a Label type (named `lblOutput`). Add these two controls to the web page designer anywhere to your liking. Next, handle the Click event for the button by adding the `OnClick` attribute in the source view, and naming the method `btnGetBrowserStats`. Your markup should look like this:

```
<strong style="font-weight: 700">Basic Request / Response Info<br />
<br />
<asp:Button ID="btnGetBrowserStats" runat="server"
    OnClick="btnGetBrowserStats_Click" Text="Get Stats" />
<br />
<br />
<asp:Label ID="lblOutput" runat="server"></asp:Label>
</strong>
```

In the code-behind for the Web Forms page, implement the handler as shown here (note the use of string interpolation, which you learned earlier in this book):

```
protected void btnGetBrowserStats_Click(object sender, EventArgs e)
{
    string theInfo = "";
    theInfo += $"<li>Is the client AOL? {Request.Browser.AOL}</li>";
    theInfo += $"<li>Does the client support ActiveX? {Request.Browser.ActiveXControls}</li>";
    theInfo += $"<li>Is the client a Beta? {Request.Browser.Beta}</li>";
    theInfo += $"<li>Does the client support Java Applets? {Request.Browser.JavaApplets}</li>";
    theInfo += $"<li>Does the client support Cookies? {Request.Browser.Cookies}</li>";
    theInfo += $"<li>Does the client support VBScript? {Request.Browser.VBScript}</li>";
    lblOutput.Text = theInfo;
}
```

Here you are testing for a number of browser capabilities. As you would guess, it is (very) helpful to discover a browser's support for ActiveX controls, Java applets, and client-side VBScript code. If the calling browser does not support a given web technology, your *.aspx page will be able to take an alternative course of action.

Access to Incoming Form Data

Other aspects of the `HttpRequest` type are the `Form` and `QueryString` properties. These two properties allow you to examine the incoming form data using name/value pairs. While you could make use of the `HttpRequest.Form` and `HttpRequest.QueryString` properties to access client-supplied form data on the web server, ASP.NET provides a more elegant, object-oriented approach. Given that ASP.NET supplies you with server-side web controls, you are able to treat HTML UI elements as true objects. Therefore, rather than obtaining the value within a text box, as in

```
protected void btnGetFormData_Click(object sender, System.EventArgs e)
{
    // Get value for a widget with ID txtFirstName.
    string firstName = Request.Form("txtFirstName");
    // Use this value in your page...
}
```

you can simply ask the server-side widget directly via the `Text` property for use in your program, like so:

```
protected void btnGetFormData_Click(object sender, System.EventArgs e)
{
    // Get value for a widget with ID txtFirstName.
    string firstName = txtFirstName.Text;
    // Use this value in your page...
}
```

To show this, add a `TextBox` and `Button` to your form. Set the `Id` for the `TextBox` to `txtFirstName` and the `Id` for the `Button` to `btnGetFormData`. Add the `OnClick` attribute, and set the value to `btnGetFormData_OnClick`, as follows:

```
<br/>
<label>First Name</label>
<asp:TextBox runat="server" Id="txtFirstName"/>
<asp:Button runat="server" Id="btnGetFormData"
    OnClick="btnGetFormData_Click" Text="Get First Name"/>
```

Implement the `btnGetFormData_Click` event handler as shown above. Run the app, enter your name in the `TextBox`, and click the `Get First Name` button. You will see the name you entered in the `Label`.

Not only does this approach lend itself to solid OO principles, but also you do not need to concern yourself with how the form data was submitted (GET or POST) before obtaining the values. Furthermore, working with the widget directly is much more type safe, given that typing errors are discovered at compile time rather than runtime. Of course, this is not to say that you will *never* need to make use of the `Form` or `QueryString` property in ASP.NET; rather, the need to do so has greatly diminished and is usually optional.

The IsPostBack Property

Another very important member of `Page` is the `IsPostBack` property. Recall that “postback” refers to a web page posting back to the same URL at the web server. Given this definition, understand that the `IsPostBack` property will return `true` if the current HTTP request has been sent by a user currently in session, and `false` if this is the user’s first interaction with the page.

Typically, the need to determine whether the current HTTP request is indeed a postback is most helpful when you need to execute a block of code only when the user first accesses a given page. For example, you might want to populate an ADO.NET `DataSet` when the user first accesses an `*.aspx` file and cache the object for later use. When the caller returns to the page, you can avoid the need to hit the database unnecessarily (of course, some pages might require that the `DataSet` always be updated upon each request, but that is another issue). Assuming your `*.aspx` file has handled the page’s `Load` event (described in detail later in this chapter), you could programmatically test for postback conditions as follows:

```
protected void Page_Load(object sender, EventArgs e)
{
    // Fill Data only the very first time
    // the user comes to this page.
    if (!IsPostBack)
    {
        // Populate Data and cache it!
    }
    // Use cached Data.
}
```

Interacting with the Outgoing HTTP Response

Now that you have a better understanding of how the `Page` type allows you to interact with the incoming HTTP request, the next step is to see how to interact with the outgoing HTTP response. In ASP.NET, the `Response` property of the `Page` class provides access to an instance of the `HttpResponse` type. This type defines a number of properties that allow you to format the HTTP response sent back to the client browser. Table 31-5 lists some core properties.

Table 31-5. *Properties of the `HttpResponse` Type*

| Property | Meaning in Life |
|--------------------------------|--|
| <code>Cache</code> | Returns the caching semantics of the web page (see Chapter 34) |
| <code>ContentEncoding</code> | Gets or sets the HTTP character set of the output stream |
| <code>ContentType</code> | Gets or sets the HTTP MIME type of the output stream |
| <code>Cookies</code> | Gets the <code>HttpCookie</code> collection that will be returned to the browser |
| <code>Output</code> | Enables text output to the outgoing HTTP content body |
| <code>OutputStream</code> | Enables binary output to the outgoing HTTP content body |
| <code>StatusCode</code> | Gets or sets the HTTP status code of output returned to the client |
| <code>StatusDescription</code> | Gets or sets the HTTP status string of output returned to the client |
| <code>SuppressContent</code> | Gets or sets a value indicating that HTTP content will not be sent to the client |

Also, consider the partial list of methods supported by the `HttpResponse` type, described in Table 31-6.

Table 31-6. *Methods of the `HttpResponse` Type*

| Method | Meaning in Life |
|--------------------------|---|
| <code>Clear()</code> | Clears all headers and content output from the buffer stream |
| <code>End()</code> | Sends all currently buffered output to the client and then closes the socket connection |
| <code>Flush()</code> | Sends all currently buffered output to the client |
| <code>Redirect()</code> | Redirects a client to a new URL |
| <code>Write()</code> | Writes values to an HTTP output content stream |
| <code>WriteFile()</code> | Writes a file directly to an HTTP content output stream |

Emitting HTML Content

Perhaps the most well-known aspect of the `HttpResponse` type is the ability to write content directly to the HTTP output stream. The `HttpResponse.Write()` method allows you to pass in any HTML tags and/or text literals. The `HttpResponse.WriteFile()` method takes this functionality one step further, in that you can specify the name of a physical file on the web server whose contents should be rendered to the output stream (this is quite helpful to quickly emit the contents of an existing *.htm file).

To illustrate, add another `Button` to your current *.aspx file like this:

```
<br/>
<asp:Button runat="server" Id="btnHttpResponse"
  OnClick="btnHttpResponse_Click" Text="Get First Name"/>
```

Now implement the server-side `Click` event handler, like so:

```
protected void btnHttpResponse_Click(object sender, EventArgs e)
{
    Response.Write("<b>My name is:</b><br>");
    Response.Write(this.ToString());
}
```

The role of this helper function (which you can assume is called by some server-side event handler) is quite simple. Again, while you can always take this old-school approach and render HTML tags and content using the `Write()` method, this approach is far less common under ASP.NET than with classic ASP. The reason is (once again) due to the advent of server-side web controls. Thus, if you want to render a block of textual data to the browser, your task is as simple as assigning a string to the `Text` property of a `Label` widget.

Redirecting Users

Another aspect of the `HttpResponse` type is the ability to redirect the user to a new URL, like so:

```
protected void btnWasteTime_Click(object sender, EventArgs e)
{
    Response.Redirect("http://www.facebook.com");
}
```

If this event handler is invoked via a client-side postback, the user will automatically be redirected to the specified URL.

■ **Note** The `HttpResponse.Redirect()` method will always entail a trip back to the client browser. If you simply want to transfer control to an `*.aspx` file in the same virtual directory, the `HttpServerUtility.Transfer()` method, accessed via the inherited `Server` property, is more efficient.

So much for investigating the functionality of `System.Web.UI.Page`. You will examine the role of the `System.Web.UI.Control` base class in the next chapter. Next up, let's examine the life and times of a Page-derived object.

■ **Source Code** The `FunWithPageMembers` web site is included in the [Chapter 31](#) subdirectory.

The Life Cycle of an ASP.NET Web Page

Every Web Forms page has a fixed life cycle. When the ASP.NET runtime receives an incoming request for a given `*.aspx` file, the associated `System.Web.UI.Page`-derived type is allocated into memory using the type's default constructor. After this point, the framework will automatically fire a series of events. By default, the `Load` event is automatically accounted for, where you can add your custom code.

```
public partial class _Default : System.Web.UI.Page
{
    protected void Page_Load(object sender, EventArgs e)
    {
        Response.Write("Load event fired!");
    }
}
```

Beyond the `Load` event, a given `Page` is able to intercept any of the core events in [Table 31-7](#), which are listed in the order in which they are encountered (consult the .NET Framework 4.6 SDK documentation for details on all possible events that may fire during a page's lifetime).

Table 31-7. *Select Events of the Page Type*

| Event | Meaning in Life |
|--|---|
| PreInit | The framework uses this event to allocate any web controls, apply themes, establish the master page, and set user profiles. You may intercept this event to customize the process. |
| Init | The framework uses this event to set the properties of web controls to their previous values via postback or view state data. |
| Load | When this event fires, the page and its controls are fully initialized, and their previous values are restored. At this point, it is safe to interact with each web widget. |
| <i>“Event that triggered the postback”</i> | There is, of course, no event of this name. This “event” simply refers to whichever event caused the browser to perform the postback to the web server (such as a Button click). |
| PreRender | All control data binding and UI configuration has occurred and the controls are ready to render their data into the outbound HTTP response. |
| Unload | The page and its controls have finished the rendering process, and the page object is about to be destroyed. At this point, it is a runtime error to interact with the outgoing HTTP response. You may, however, capture this event to perform any page-level cleanup (close file or database connections, perform any form of logging activity, dispose of objects, etc.). |

When a C# programmer needs to handle events beyond Load, you might be surprised to find that there is no IDE support to do so! Rather, you must manually author a method in your code file, taking the name Page_NameOfEvent. For example, here is how you can handle the Unload event:

```
public partial class _Default : System.Web.UI.Page
{
    protected void Page_Load(object sender, EventArgs e)
    {
        Response.Write("Load event fired!");
    }

    protected void Page_Unload(object sender, EventArgs e)
    {
        // No longer possible to emit data to the HTTP
        // response, so we will write to a local file.
        System.IO.File.WriteAllText(@"C:\MyLog.txt", "Page unloading!");
    }
}
```

■ **Note** Each event of the Page type works in conjunction with the System.EventHandler delegate; therefore, the subroutines that handle these events always take an Object as the first parameter and an EventArgs as the second parameter.

The Role of the AutoEventWireup Attribute

When you want to handle events for your page, you need to update your `<script>` block or code-behind file with an appropriate event handler. However, if you examine the `<%@Page%>` directive, you will notice a specific attribute named `AutoEventWireUp`, which, by default, is set to `true`.

```
<%@ Page Language="C#" AutoEventWireup="true"
    CodeFile="Default.aspx.cs" Inherits="_Default" %>
```

With this default behavior, each page-level event handler will automatically be handled if you enter the appropriately named method. However, if you disable `AutoPageWireUp` by setting this attribute to `false`, as in

```
<%@ Page Language="C#" AutoEventWireup="false"
    CodeFile="Default.aspx.cs" Inherits="_Default" %>
```

the page-level events will no longer be captured. As its name suggests, this attribute (when enabled) will generate the necessary event riggings within the autogenerated partial class described earlier in this chapter. Even if you disable `AutoEventWireup`, you can still process page-level events by making use of C# event-handling logic, like so:

```
public _Default()
{
    // Explicitly hook into the Load and Unload events.
    this.Load += Page_Load;
    this.Unload += Page_Unload;
}
```

As you might suspect, you will usually leave `AutoEventWireup` enabled.

The Error Event

Another event that may occur during your page's life cycle is `Error`. This event will be fired if a method on the Page-derived type triggered an exception that was not explicitly handled. Assume that you have handled the `Click` event for a given `Button` on your page, and within the event handler (named `btnGetFile_Click`), you attempt to write out the contents of a local file to the HTTP response.

Also assume you have *failed* to test for the presence of this file via standard structured exception handling. If you have rigged up the page's `Error` event in the default constructor, you have one final chance to deal with the problem on this page before the end user finds an ugly error. Consider the following code:

```
public partial class _Default : System.Web.UI.Page
{
    void Page_Error(object sender, EventArgs e)
    {
        Response.Clear();
        Response.Write("I am sorry...I can't find a required file.<br>");
        Response.Write($"The error was: <b>{ Server.GetLastError().Message }</b>");
        Server.ClearError();
    }
}
```

```

protected void Page_Load(object sender, EventArgs e)
{
    Response.Write("Load event fired!");
}

protected void Page_Unload(object sender, EventArgs e)
{
    // No longer possible to emit data to the HTTP
    // response at this point, so we will write to a local file.
    System.IO.File.WriteAllText(@"C:\MyLog.txt", "Page unloading!");
}

protected void btnPostBack_Click(object sender, EventArgs e)
{
    // Nothing happens here. This is just to ensure a
    // postback to the page.
}

protected void btnTriggerError_Click(object sender, EventArgs e)
{
    System.IO.File.ReadAllText(@"C:\IDontExist.txt");
}
}

```

Notice that your Error event handler begins by clearing out any content currently within the HTTP response and emits a generic error message. If you want to gain access to the specific `System.Exception` object, you may do so using the `HttpServerUtility.GetLastError()` method exposed by the inherited `Server` property.

```
Exception e = Server.GetLastError();
```

Finally, note that before exiting this generic error handler, you are explicitly calling the `HttpServerUtility.ClearError()` method via the `Server` property. This is required because it informs the runtime that you have dealt with the issue at hand and require no further processing. If you forget to do so, the end user will be presented with the runtime's error page.

At this point, you should feel confident with the composition of an ASP.NET Page type. Now that you have such a foundation, you can turn your attention to the role of Web Forms controls, themes, and master pages, all of which are the subject of remaining chapters. To wrap up this chapter, however, let's examine the role of the `Web.config` file.

■ **Source Code** The `PageLifecycle` web site is included in the Chapter 31 subdirectory.

The Role of the Web.config File

By default, all C# Web Forms applications created with Visual Studio are automatically provided with a `Web.config` file. However, if you ever need to manually insert a `Web.config` file into your site (e.g., when you are working with the single-page model and have not created a web solution), you may do so using the Website ► Add New Item menu option. In either case, within this scope of a `Web.config` file you are able to add settings that control how your web application will function at runtime.

During your examination of .NET assemblies (in Chapter 14) you learned that client applications can leverage an XML-based configuration file to instruct the CLR how it should handle binding requests, assembly probing, and other runtime details. The same holds true for Web Forms applications, with the notable exception that web-centric configuration files are always named `Web.config` (unlike `*.exe` configuration files, which are named based on the related client executable).

The full structure of a `Web.config` file is rather verbose. However, Table 31-8 outlines some of the more interesting subelements that can be found within a `Web.config` file.

Table 31-8. *Select Elements of a Web.config File*

| Element | Meaning in Life |
|--|---|
| <code><appSettings></code> | This element is used to establish custom name/value pairs that can be programmatically read in memory for use by your pages using the <code>ConfigurationManager</code> type. |
| <code><authentication></code> | This security-related element is used to define the authentication mode for this web application. |
| <code><authorization></code> | This is another security-centric element used to define which users can access which resources on the web server. |
| <code><connectionStrings></code> | This element is used to hold external connection strings used within this web site. |
| <code><customErrors></code> | This element is used to tell the runtime exactly how to display errors that occur during the functioning of the web application. |
| <code><globalization></code> | This element is used to configure the globalization settings for this web application. |
| <code><namespaces></code> | This element documents all of the namespaces to include if your web application has been precompiled using the new <code>aspnet_compiler.exe</code> command-line tool. |
| <code><sessionState></code> | This element is used to control how and where session state data will be stored by the .NET runtime. |
| <code><trace></code> | This element is used to enable (or disable) tracing support for this web application. |

A `Web.config` file may contain additional subelements above and beyond the set presented in Table 31-8. The vast majority of these items are security related, while the remaining items are useful only during advanced ASP.NET scenarios, such as creating custom HTTP headers or custom HTTP modules (topics that are not covered here).

The ASP.NET Web Site Administration Utility

Although you are always free to modify the content of a `Web.config` file directly using Visual Studio, Web Forms projects can make use of a handy web-based editor that will allow you to graphically edit numerous elements and attributes of your project's `Web.config` file. To launch this tool, activate the Website ► ASP.NET Configuration menu option.

If you click the tabs located on the top of the page, you will quickly notice that most of this tool's functionality is used to establish security settings for your web site. However, this tool also makes it possible to add settings to your `<appSettings>` element, define debugging and tracing settings, and establish a default error page.

You'll see more of this tool in action where necessary; however, do be aware that this utility will *not* allow you to add all possible settings to a `Web.config` file. There will most certainly be times when you will need to manually update this file using your text editor of choice.

Summary

Building web applications requires a different frame of mind than that used to assemble traditional desktop applications. In this chapter, you began with a quick and painless review of some core web topics, including HTML, HTTP, the role of client-side scripting, and server-side scripts using classic ASP. The bulk of this chapter was spent examining the architecture of an ASP.NET page. As you have seen, each `*.aspx` file in your project has an associated `System.Web.UI.Page`-derived class. Using this OO approach, ASP.NET allows you to build more reusable and OO-aware systems.

After examining some of the core functionality of a page's inheritance chain, this chapter then discussed how your pages are ultimately compiled into a valid .NET assembly. You wrapped up this chapter by exploring the role of the `Web.config` file and overviewed the ASP.NET Web Site Administration tool.

CHAPTER 32



ASP.NET Web Controls, Master Pages, and Themes

The previous chapter concentrated on the general composition of an Web Forms page and the role of the Page class. This chapter will dive into the details of the *web controls* that make up a page's user interface. After examining the overall nature of an Web Forms control, you will learn how to use several UI elements, including validation controls and various data-binding techniques.

The good portion of this chapter will examine the role of *master pages* and show how they provide a simplified way to establish a common UI skeleton that will be replicated across the pages in your web site. Closely related to the topic of master pages is the use of site navigation controls (and a related *.sitemap file) in order to define the navigational structure of a multipage site via a server-side XML file.

To wrap things up, you will learn about the role of Web Forms themes. Conceptually, themes serve the same purpose as a cascading style sheet (CSS); however, Web Forms themes are applied on the web server (as opposed to within the client-side browser) and, therefore, have access to server-side resources.

Understanding the Nature of Web Controls

A major benefit of Web Forms is the ability to assemble the UI of your pages using the types defined in the System.Web.UI.WebControls namespace. As you have seen, these controls (which go by the names *server controls*, *web controls*, or *Web Form controls*) are extremely helpful in that they automatically generate the necessary HTML for the requesting browser and expose a set of events that may be processed on the web server. Furthermore, because each Web Forms control has a corresponding class in the System.Web.UI.WebControls namespace, it can be manipulated in an object-oriented manner.

When you configure the properties of a web control using the Visual Studio Properties window, your edits are recorded in the opening control tag of a given element in the *.aspx file as a series of name/value pairs. Thus, if you add a new TextBox to the designer of a given *.aspx file and change the ID, BorderStyle, BorderWidth, BackColor, and Text properties, the opening <asp:TextBox> tag is modified accordingly (however, note that the Text value becomes the inner text of the TextBox scope).

```
<asp:TextBox ID="txtNameTextBox" runat="server" BackColor="#C0FFC0"
    BorderStyle="Dotted" BorderWidth="3px">Enter Your Name</asp:TextBox>
```

Given that the declaration of a web control eventually becomes a member variable from the `System.Web.UI.WebControls` namespace (via the dynamic compilation cycle mentioned in Chapter 31), you can interact with the members of this type within a server-side `<script>` block or more commonly via the page's code-behind file. Thus, if you were to add a new `Button` control to an `*.aspx` file, you could handle the `Click` event and write a server-side handler that changes the background color of the `TextBox`, like so:

```
partial class _Default : System.Web.UI.Page
{
    protected void btnChangeTextBoxColor_Click(object sender, EventArgs e)
    {
        // Change color of text box object in code.
        this.txtNameTextBox.BackColor = System.Drawing.Color.DarkBlue;
    }
}
```

All Web Forms controls ultimately derive from a common base class named `System.Web.UI.WebControls.WebControl`. In turn, `WebControl` derives from `System.Web.UI.Control` (which derives from `System.Object`). `Control` and `WebControl` each define a number of properties common to all server-side controls. Before you examine the inherited functionality, let's formalize what it means to handle a server-side event.

Understanding Server-Side Event Handling

Given the current state of the World Wide Web, it is impossible to avoid the fundamental nature of browser/web server interaction. Whenever these two entities communicate, there is always an underlying, stateless HTTP request-and-response cycle. While Web Forms server controls do a great deal to shield you from the details of the raw HTTP protocol, always remember that treating the Web as an event-driven entity is just a magnificent smoke-and-mirrors show provided by the .NET platform, and it is not identical to the event-driven model of a Windows-based desktop GUI framework such as WPF.

For example, although the WPF-centric `System.Windows.Controls` namespace and the Web Forms `System.Web.UI.WebControls` namespace both define classes with the same simple names (`Button`, `TextBox`, `Label`, and so on) they do not expose an identical set of properties, methods, or events. For example, there is no way to handle a server-side `MouseMove` event when the user moves the cursor over a Web Form `Button` control.

The bottom line is that a given Web Forms control will expose a limited set of events, all of which ultimately result in a postback to the web server. Any necessary client-side event processing will require you to author blurbs of *client-side* JavaScript/VBScript script code to be processed by the requesting browser's scripting engine. Given that Web Forms is primarily a server-side technology, I will not be addressing the topic of authoring client-side scripts.

■ **Note** Handling an event for a given web control using Visual Studio can be done in an identical manner as doing so for a Windows GUI control. Simply select the widget from the designer and click the lightning bolt icon on the Properties window.

The AutoPostBack Property

It is also worth pointing out that many of the Web Forms controls support a property named `AutoPostBack` (most notably, the `CheckBox`, `RadioButton`, and `TextBox` controls, as well as any widget that derives from the abstract `ListControl` type). By default, this property is set to `false`, which disables an immediate postback to the server (even if you have indeed rigged up the event in the code-behind file). In most cases, this is the exact behavior you require, given that UI elements, such as check boxes, typically don't require postback functionality. In other words, you don't want to post back to the server immediately after the user checks or unchecks a check box, as the page object can obtain the state of the widget within a more natural `Button Click` event handler.

However, if you want to cause any of these widgets to post back to a server-side event handler immediately, simply set the value of `AutoPostBack` to `true`. This technique can be helpful if you want to have the state of one widget automatically populate another value within another widget on the same page. To illustrate, assume you have a web page that contains a single `TextBox` (named `txtAutoPostBack`) and a single `ListBox` control (named `lstTextBoxData`). Here is the relevant markup:

```
<form id="form1" runat="server">
  <asp:TextBox ID="txtAutoPostBack" runat="server"></asp:TextBox>
  <br/>
  <asp:ListBox ID="lstTextBoxData" runat="server"></asp:ListBox>
</form>
```

Now, if you were to handle the `TextChanged` event of the `TextBox`, the server-side event handler could attempt to populate the `ListBox` with the current value in the `TextBox`, like so:

```
partial class _Default : System.Web.UI.Page
{
  protected void txtAutoPostBack_TextChanged(object sender, EventArgs e)
  {
    lstTextBoxData.Items.Add(txtAutoPostBack.Text);
  }
}
```

If you run the application as is, you will find that as you type in the `TextBox`, nothing happens.

Furthermore, if you type in the `TextBox` and tab to the next control, nothing happens. The reason is that the `AutoPostBack` property of the `TextBox` is set to `false` by default. However, if you set this property to `true`, as in

```
<asp:TextBox ID="txtAutoPostBack" runat="server"
  AutoPostBack="true" ... >
</asp:TextBox>
```

you will find that when you tab away from the `TextBox` (or press the `Enter` key), the `ListBox` is automatically populated with the current value in the `TextBox`. To be sure, beyond the need to populate the items of one widget based on the value of another widget, you won't typically need to alter the state of a widget's `AutoPostBack` property (and even then, sometimes this can be accomplished purely in client script, removing the need for server interaction at all).

The Control and WebControl Base Classes

The `System.Web.UI.Control` base class defines various properties, methods, and events that provide the ability to interact with core (typically non-GUI) aspects of a web control. Table 32-1 documents some, but not all, members of interest.

Table 32-1. *Select Members of `System.Web.UI.Control`*

| Member | Meaning in Life |
|----------------------------|---|
| Controls | This property gets a <code>ControlCollection</code> object that represents the child controls within the current control. |
| <code>DataBind()</code> | This method binds a data source to the invoked server control and all of its child controls. |
| <code>EnableTheming</code> | This property establishes whether the control supports theme functionality (the default is <code>true</code>). |
| <code>HasControls()</code> | This method determines whether the server control contains any child controls. |
| ID | This property gets or sets the programmatic identifier assigned to the server control. |
| Page | This property gets a reference to the <code>Page</code> instance that contains the server control. |
| Parent | This property gets a reference to the server control's parent control in the page control hierarchy. |
| SkinID | This property gets or sets the skin to apply to the control, which allows you to set the look and feel using server-side resources. |
| Visible | This property gets or sets a value that indicates whether a server control is rendered as a UI element on the page. |

Enumerating Contained Controls

The first aspect of `System.Web.UI.Control` that you will examine is the fact that all web controls (including `Page` itself) inherit a custom controls collection (accessed via the `Controls` property). Much like in a Windows Forms application, the `Controls` property provides access to a strongly typed collection of `WebControl`-derived types. Like any .NET collection, you have the ability to add, insert, and remove items dynamically at runtime.

While it is technically possible to add web controls directly to a `Page`-derived type, it is easier (and more robust) to make use of a `Panel` control. The `Panel` class represents a container of widgets that may or may not be visible to the end user (based on the value of its `Visible` and `BorderStyle` properties).

To illustrate, create a new empty web site named `DynamicCtrls` and add a new Web Forms to your project. Using the Visual Studio page designer, add a `Panel` control (named `myPanel`) that contains a `TextBox`, `Button`, and `HyperLink` widget named whatever you choose (be aware that the designer requires that you drag internal items within the UI of the `Panel` type). Next, place a `Label` widget outside the scope of the `Panel` (named `lblControlInfo`) to hold the rendered output. Here is one possible HTML description:

```
<html xmlns="http://www.w3.org/1999/xhtml">
<head runat="server">
  <title>Dynamic Control Test</title>
</head>
```

```

<body>
  <form id="form1" runat="server">
    <div>
      <hr />
      <h1>Dynamic Controls</h1>
      <asp:Label ID="lblTextBoxText" runat="server"></asp:Label>
      <hr />
    </div>
    <!-- The Panel has three contained controls -->
    <asp:Panel ID="myPanel" runat="server" Width="200px"
      BorderColor="Black" BorderStyle="Solid" >
      <asp:TextBox ID="TextBox1" runat="server"></asp:TextBox><br/>
      <asp:Button ID="Button1" runat="server" Text="Button"/><br/>
      <asp:HyperLink ID="HyperLink1" runat="server">HyperLink
      </asp:HyperLink>
    </asp:Panel>
    <br />
    <br />
    <asp:Label ID="lblControlInfo" runat="server"></asp:Label>
  </form>
</body>
</html>

```

With this markup, your page designer will look something like Figure 32-1.

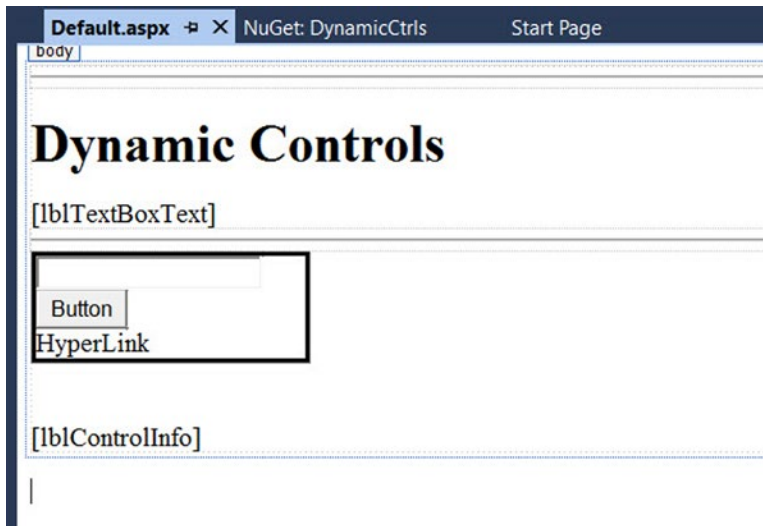

Figure 32-1. The UI of the Dynamic Controls web page

Assume in the `Page_Load()` event that you want to obtain details regarding the controls contained within the `Panel` and assign this information to the `Label` control (named `lblControlInfo`). Consider the following C# code:

```
public partial class _Default : System.Web.UI.Page
{
    protected void Page_Load(object sender, System.EventArgs e)
    {
        ListControlsInPanel();
    }

    private void ListControlsInPanel()
    {
        var theInfo = "";
        theInfo = $"<b>Does the panel have controls? {myPanel.HasControls()} </b><br/>";
        // Get all controls in the panel.
        foreach (Control c in myPanel.Controls)
        {
            if (!object.ReferenceEquals(c.GetType(), typeof(System.Web.UI.LiteralControl)))
            {
                theInfo += "*****<br/>";
                theInfo += $"Control Name? {c} <br/>";
                theInfo += $"ID? {c.ID} <br/>";
                theInfo += $"Control Visible? {c.Visible} <br/>";
                theInfo += $"ViewState? {c.EnableViewState} <br/>";
            }
        }
        lblControlInfo.Text = theInfo;
    }
}
```

Here, you iterate over each `WebControl` maintained on the `Panel` and perform a check to see whether the current type is of type `System.Web.UI.LiteralControl`, and if so, you skip over it. This class is used to represent literal HTML tags and content (such as `
`, text literals, etc.). If you do not do this sanity check, you might be surprised to find many more controls in the scope of the `Panel` (given the `*.aspx` declaration seen previously). Assuming the control is not literal HTML content, you then print out some various statistics about the widget. Figure 32-2 shows the output.

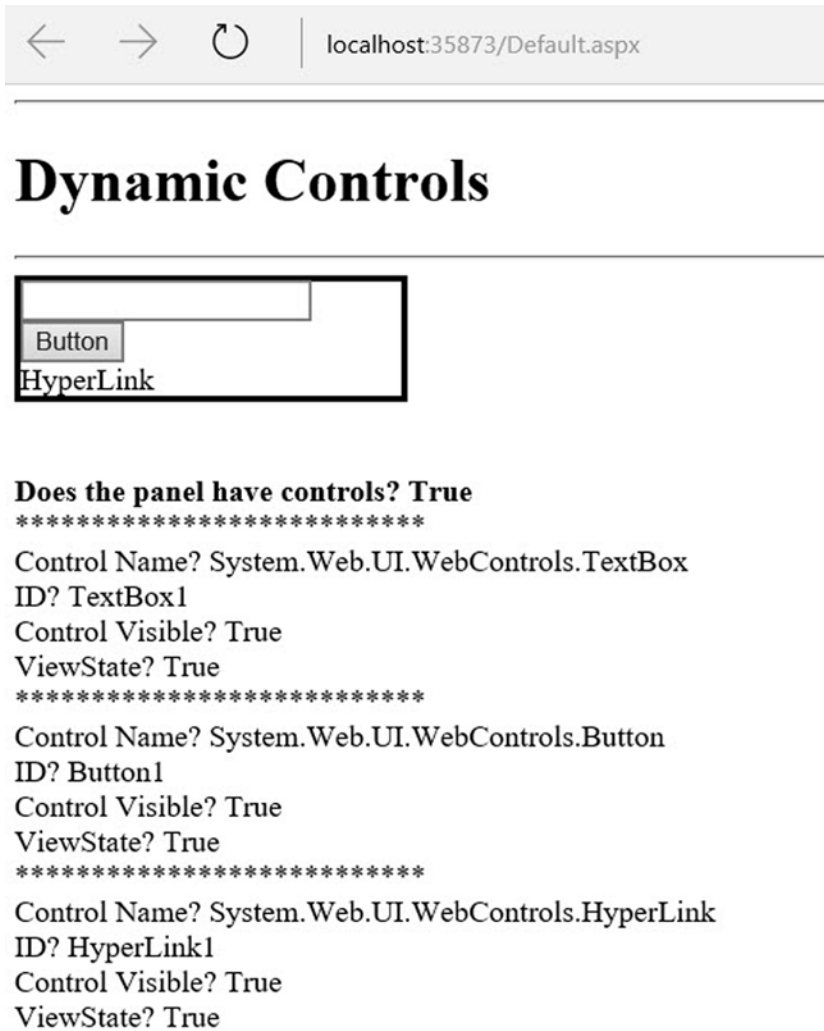

Figure 32-2. Enumerating controls at runtime

Dynamically Adding and Removing Controls

Now, what if you want to modify the contents of a `Panel` at runtime? Let's update the current page to support an additional `Button` (named `btnAddWidgets`) that dynamically adds three new `TextBox` controls to the `Panel` and another `Button` (named `btnClearPanel`) that clears the `Panel` widget of all controls. The `Click` event handlers for each are shown here:

```
protected void btnClearPanel_Click(object sender, System.EventArgs e)
{
    // Clear all content from the panel, then relist items.
    myPanel.Controls.Clear();
    ListControlsInPanel();
}
protected void btnAddWidgets_Click(object sender, System.EventArgs e)
{
    for (int i = 0; i < 3; i++)
    {
        // Assign an ID so we can get
        // the text value out later
        // using the incoming form data.
        TextBox t = new TextBox {ID = $"newTextBox{i}"};
        myPanel.Controls.Add(t);
        ListControlsInPanel();
    }
}
```

Notice that you assign a unique ID to each `TextBox` (e.g., `newTextBox0`, `newTextBox1`, and so on). If you run your page, you should be able to add new items to the `Panel` control and clear the `Panel` of all content.

Interacting with Dynamically Created Controls

Now, if you want to obtain the values within these dynamically generated `TextBoxes`, you can do so in a variety of ways. First, update your UI with one additional `Button` (named `btnGetTextData`), a final `Label` control named `lblTextBoxData`, and handle the `Click` event for the `Button`.

To get access to the data within the dynamically created text boxes, you have a few options. One approach is to loop over each item contained within the incoming HTML form data (accessed via `HttpRequest.Form`) and concatenate the textual information to a locally scoped `System.String`. Once you have exhausted the collection, assign this string to the `Text` property of the new `Label` control, like so:

```
protected void btnGetTextData_Click(object sender, System.EventArgs e)
{
    string textBoxValues = "";
    for (int i = 0; i < Request.Form.Count; i++)
    {
        textBoxValues += $"<li>{ Request.Form[i]}</li><br/>";
    }
    lblTextBoxData.Text = textBoxValues;
}
```

When you run the application, you will find that you are able to view the content of each text box, including some rather long (unreadable) string data. This string contains the *view state* for each control on the page. You'll learn about the role of the view state in Chapter 33.

To clean up the output, you could instead pluck out the textual data for your uniquely named items (newTextBox0, newTextBox1, and newTextBox2). Consider the following update:

```
protected void btnGetTextData_Click(object sender, System.EventArgs e)
{
    // Get each text box by name.
    string lableData = "<li>{Request.Form.Get("newTextBox0")}</li><br/>";
    lableData += "<li>{Request.Form.Get("newTextBox1")}</li><br/>";
    lableData += "<li>{Request.Form.Get("newTextBox2")}</li><br/>";
    lblTextBoxData.Text = lableData;
}
```

Using either approach, you will notice that once the request has been processed, the text boxes disappear. Again, the reason has to do with the stateless nature of HTTP. If you want to maintain these dynamically created TextBoxes between postbacks, you need to persist these objects using Web Forms state programming techniques (again, see Chapter 33).

■ **Source Code** The DynamicCtrls web site is included in the Chapter 32 subdirectory.

Functionality of the WebControl Base Class

As you can tell, the Control type provides a number of non-GUI-related behaviors (the controls collection, autopostback support, etc.). On the other hand, the WebControl base class provides a graphical polymorphic interface to all web widgets, as suggested in Table 32-2.

Table 32-2. Select Properties of the WebControl Base Class

| Property | Meaning in Life |
|---------------|---|
| BackColor | Gets or sets the background color of the web control |
| BorderColor | Gets or sets the border color of the web control |
| BorderStyle | Gets or sets the border style of the web control |
| BorderWidth | Gets or sets the border width of the web control |
| Enabled | Gets or sets a value indicating whether the web control is enabled |
| CssClass | Allows you to assign a class defined within a Cascading Style Sheet to a web widget |
| Font | Gets font information for the web control |
| ForeColor | Gets or sets the foreground color (typically the color of the text) of the web control |
| Height, Width | Get or set the height and width of the web control |
| TabIndex | Gets or sets the tab index of the web control |
| ToolTip | Gets or sets the tool tip for the web control to be displayed when the cursor is over the control |

Almost all of these properties are self-explanatory, so rather than drill through the use of them one by one, let's instead check out a number of ASP.NET Web Forms controls in action.

Major Categories of Web Forms Controls

The Web Forms control library can be broken down into several broad categories, all of which can be viewed within the Visual Studio Toolbox (provided you have an *.aspx page open for design) (see Figure 32-3).

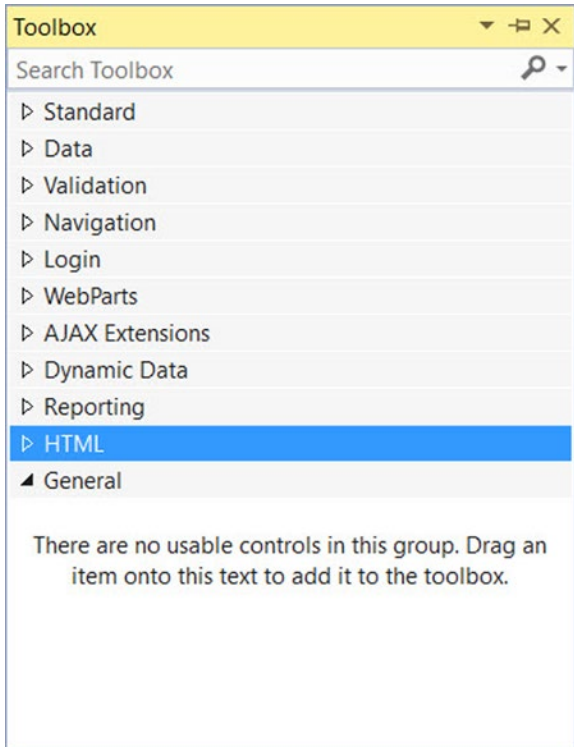

Figure 32-3. The categories of Web Forms controls

Under the Standard area of the Toolbox, you will find the most frequently used controls, including Button, Label, TextBox, and ListBox. In addition to these vanilla-flavored UI elements, the Standard area also lists more exotic web controls, such as Calendar, Wizard, and AdRotator (see Figure 32-4).

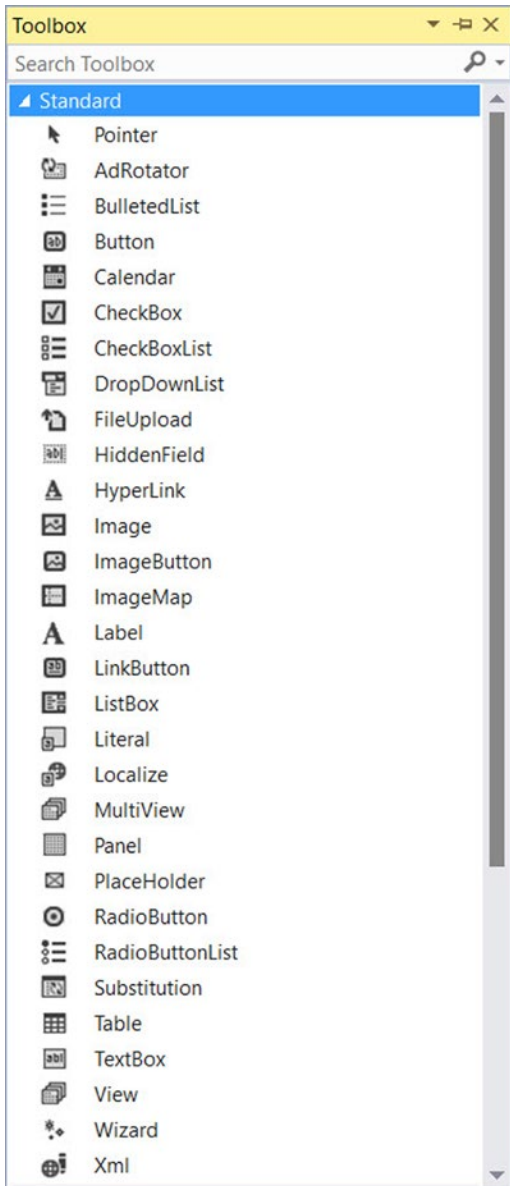

Figure 32-4. The standard Web Forms controls

The Data section is where you can find a set of controls used for data-binding operations, including the Web Forms Chart control, which allows you to render out graphical chart data (pie charts, line charts) typically as the result of a data-binding operation (see Figure 32-5).

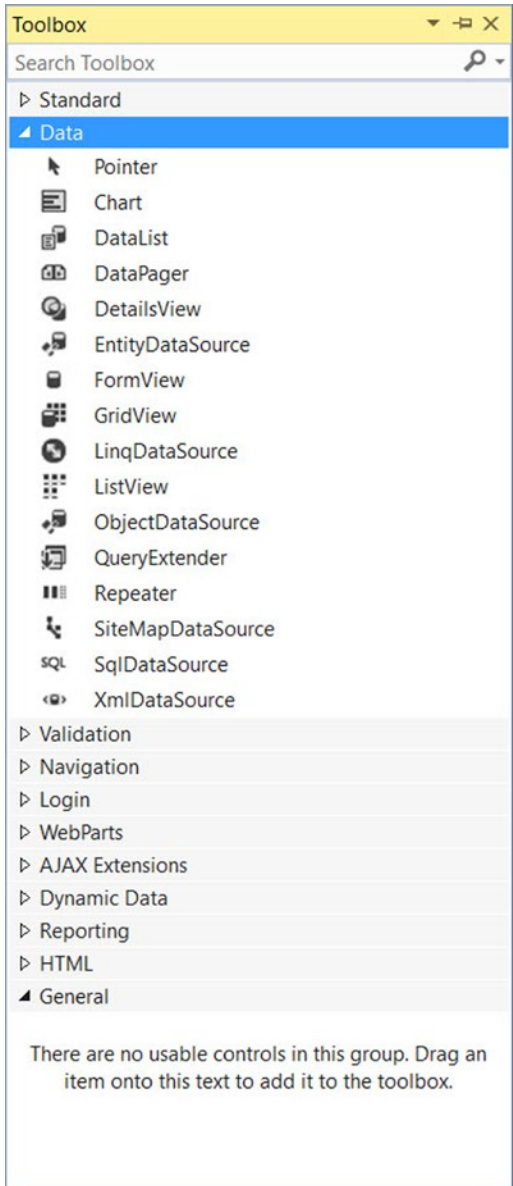

Figure 32-5. Data-centric Web Forms controls

The Web Forms validation controls (found in the Validation area of the Toolbox) are very interesting in that they can be configured to emit back blocks of client-side JavaScript that will test input fields for valid data. If a validation error occurs, the user will see an error message and will not be allowed to post back to the web server until the error is corrected.

The Navigation node of the Toolbox is where you will find a small set of controls (Menu, SiteMapPath, and TreeView), which typically work in conjunction with a *.sitemap file. As briefly mentioned earlier in this chapter, these navigation controls allow you to describe the structure of a multipage site using XML descriptions.

The most exotic set of Web Forms controls would have to be the Login controls (see Figure 32-6).

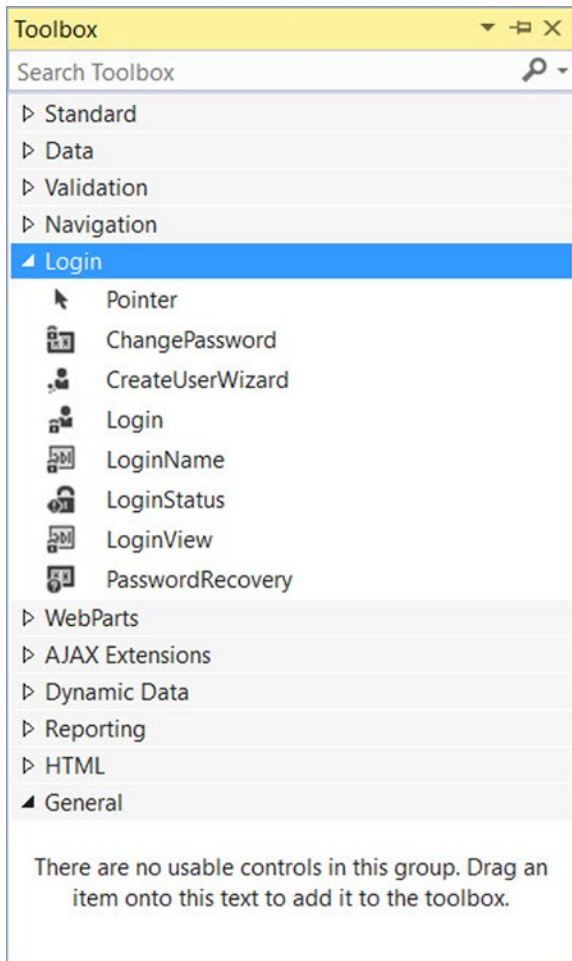

Figure 32-6. Security Web Forms controls

These controls can radically simplify how to incorporate basic security features (password recovery, login screens, etc.) into your web applications. In fact, these controls are so powerful, they will even dynamically create a dedicated database to store credentials (saved under the `App_Data` folder of your web site) if you do not already have a specific security database.

■ **Note** The remaining categories of web controls shown in the Visual Studio Toolbox (such as WebParts, AJAX Extensions, and Dynamic Data) are for more specialized programming needs and will not be examined here.

A Brief Word Regarding `System.Web.UI.HtmlControls`

Truth be told, there are two distinct web control toolkits that ship with Web Forms. In addition to the Web Forms controls (within the `System.Web.UI.WebControls` namespace), the base class libraries also provide the `System.Web.UI.HtmlControls` control library.

The HTML controls are a collection of types that allow you to make use of traditional HTML controls on a Web Forms page. However, unlike simple HTML tags, HTML controls are object-oriented entities that can be configured to run on the server and thus support server-side event handling. Unlike Web Forms controls, HTML controls are quite simplistic in nature and offer little functionality beyond standard HTML tags (`HtmlButton`, `HtmlInputControl`, `HtmlTable`, etc.).

The HTML controls can be useful if your team has a clear division between those who build HTML UIs and .NET developers. HTML folks can make use of their web editor of choice using familiar markup tags and pass the HTML files to the development team. At this point, the developers can configure these HTML controls to run as server controls (by right-clicking an HTML widget within Visual Studio). This will allow the developers to handle server-side events and work with the HTML widget programmatically.

The HTML controls provide a public interface that mimics standard HTML attributes. For example, to obtain the information within an input area, you make use of the `Value` property rather than the web control-centric `Text` property. Given that the HTML controls are not as feature-rich as the Web Forms controls, I won't make further mention of them in this text.

Web Control Documentation

You will get a chance to work with a number of Web Forms controls during the remainder of this book; however, you should certainly take a moment to search the .NET Framework 4.6 SDK documentation for the `System.Web.UI.WebControls` namespace. Here, you will find explanations and code examples for each member of the namespace (see Figure 32-7).

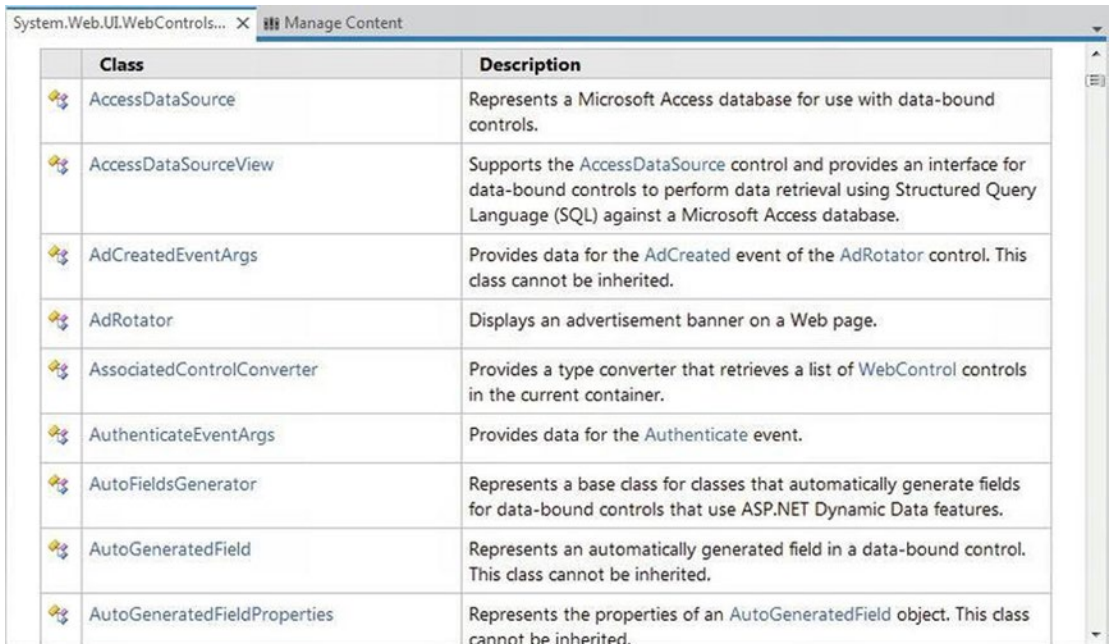

| Class | Description |
|------------------------------|--|
| AccessDataSource | Represents a Microsoft Access database for use with data-bound controls. |
| AccessDataSourceView | Supports the AccessDataSource control and provides an interface for data-bound controls to perform data retrieval using Structured Query Language (SQL) against a Microsoft Access database. |
| AdCreatedEventArgs | Provides data for the AdCreated event of the AdRotator control. This class cannot be inherited. |
| AdRotator | Displays an advertisement banner on a Web page. |
| AssociatedControlConverter | Provides a type converter that retrieves a list of WebControl controls in the current container. |
| AuthenticateEventArgs | Provides data for the Authenticate event. |
| AutoFieldsGenerator | Represents a base class for classes that automatically generate fields for data-bound controls that use ASP.NET Dynamic Data features. |
| AutoGeneratedField | Represents an automatically generated field in a data-bound control. This class cannot be inherited. |
| AutoGeneratedFieldProperties | Represents the properties of an AutoGeneratedField object. This class cannot be inherited. |

Figure 32-7. All Web Forms controls are documented in the .NET Framework 4.6 SDK documentation

Building the Web Forms Cars Web Site

Given that many of the “simple” controls look and feel so close to their Windows GUI counterparts, I won’t bother to enumerate the details of the basic widgets (Buttons, Labels, TextBoxes, etc.). Rather, let’s build a new web site that illustrates working with several of the more exotic controls, as well as the Web Forms master page model and aspects of the data-binding engine. Specifically, this next example will illustrate the following techniques:

- Working with master pages
- Working with site map navigation
- Working with the GridView control
- Working with the Wizard control

To begin, create an empty web site project named `AspNetCarsSite`. Note that you are not yet creating a new full ASP.NET web site project because this will add a number of starter files to the mix that we have not yet examined. For this project, you will add what you need manually.

Working with Web Forms Master Pages

Many web sites provide a consistent look and feel across multiple pages (a common menu navigation system, common header and footer content, company logo, etc.). A master page is little more than an Web Forms page that takes a *.master file extension. On their own, master pages are not viewable from a client-side browser (in fact, the ASP.NET runtime will not serve this flavor of web content). Rather, master pages define a common UI layout shared by all pages (or a subset of pages) in your site.

As well, a *.master page will define various content placeholder areas that establish a region of UI real estate that other *.aspx files may plug into. As you will see, *.aspx files that plug their content into a master file look and feel a bit different from the *.aspx files you have been examining. Specifically, this flavor of an *.aspx file is termed a *content page*. Content pages are *.aspx files that do not define an HTML <form> element (that is the job of the master page).

However, as far as the end user is concerned, a request is made to a given *.aspx file. On the web server, the related *.master file and any related *.aspx content pages are blended into a single unified HTML page declaration.

To illustrate the use of master pages and content pages, begin by inserting a new master page into your web site via the Website Add New Item menu selection (Figure 32-8 shows the resulting dialog box).

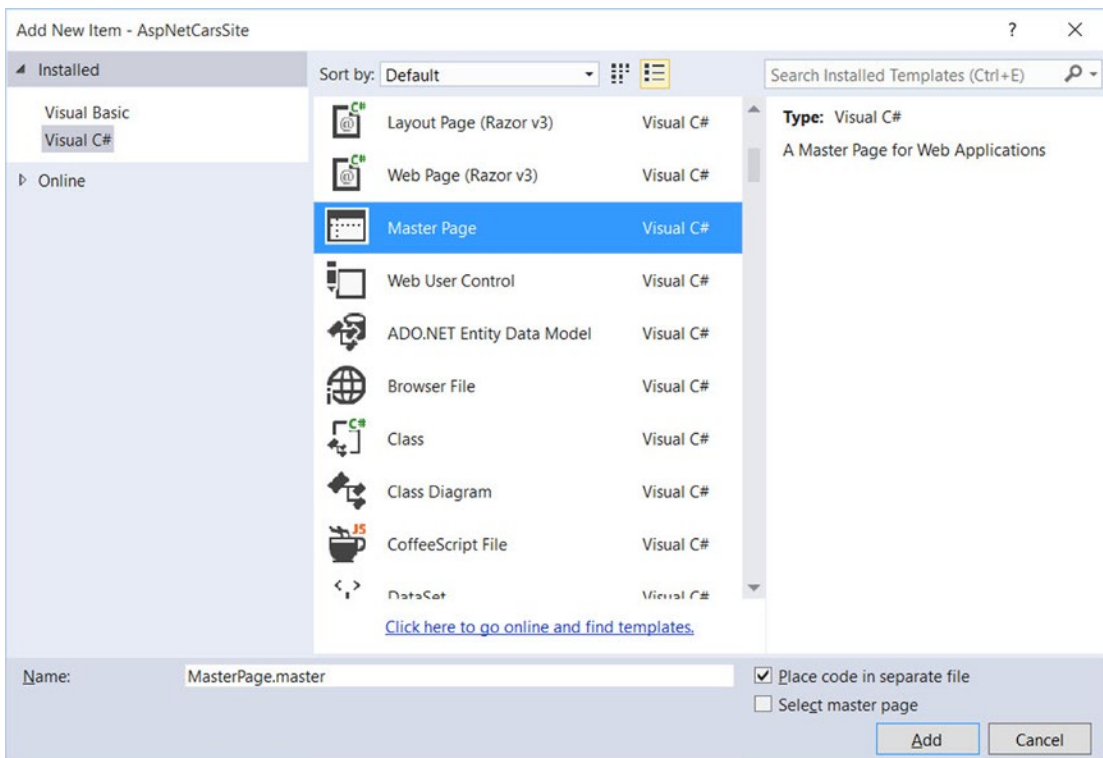

Figure 32-8. Inserting a new *.master file

The initial markup of the MasterPage.master file looks like the following:

```
<%@ Master Language="C#" AutoEventWireup="true" CodeFile="MasterPage.master.cs"
Inherits="MasterPage" %>

<!DOCTYPE html>

<html xmlns="http://www.w3.org/1999/xhtml">
<head runat="server">
  <title></title>
  <asp:ContentPlaceholder id="head" runat="server">
```



```

    </asp:ContentPlaceHolder>
</head>
<body>
  <form id="form1" runat="server">
    <div>
      <asp:ContentPlaceHolder id="ContentPlaceHolder1" runat="server">
        </asp:ContentPlaceHolder>
      </div>
    </form>
  </body>
</html>

```

The first point of interest is the new `<%@Master%>` directive. For the most part, this directive supports the same attributes as the `<%@Page%>` directive described in Chapter 31. Like Page types, a master page derives from a specific base class, which in this case is `MasterPage`. If you were to open up your related code file, you would find the following class definition:

```

public partial class MasterPage : System.Web.UI.MasterPage
{
    protected void Page_Load(object sender, EventArgs e)
    {
    }
}

```

The other point of interest within the markup of the master is the `<asp:ContentPlaceHolder>` definition. This region of a master page represents the area of the master that the UI widgets of the related `*.aspx` content file may plug into, not the content defined by the master page itself.

If you do intend to plug in an `*.aspx` file within this region, the scope within the `<asp:ContentPlaceHolder>` and `</asp:ContentPlaceHolder>` tags will typically remain empty. However, you can populate this area with various web controls that function as a default UI to use in the event that a given `*.aspx` file in the site does not supply specific content. For this example, assume that each `*.aspx` page in your site will indeed supply custom content and, therefore, your `<asp:ContentPlaceHolder>` elements will be empty.

■ **Note** A `*.master` page may define as many content placeholders as necessary. As well, a single `*.master` page may nest additional `*.master` pages.

You can build a common UI of a `*.master` file using the same Visual Studio designers used to build `*.aspx` files. For this site, you will add a descriptive `Label` (to serve as a common welcome message), an `AdRotator` control (which will randomly display one of two image files), and a `TreeView` control (to allow the user to navigate to other areas of the site). Here is my markup after designing my master page via the IDE:

```

<html xmlns="http://www.w3.org/1999/xhtml">
<head runat="server">
  <title> </title>
  <asp:ContentPlaceHolder id="head" runat="server">
    </asp:ContentPlaceHolder>
</head>
<body>

```

```

<form id="form1" runat="server">
  <div>
    <hr />
    <asp:Label ID="Label1" runat="server" Font-Size="XX-Large"
      Text="Welcome to the ASP.NET Cars Super Site!"></asp:Label>
    <asp:AdRotator ID="myAdRotator" runat="server"/>
    &nbsp;<br />
    <br />
    <asp:TreeView ID="navigationTree" runat="server">
    </asp:TreeView>
    <hr />
  </div>
  <div>
    <asp:ContentPlaceHolder id="ContentPlaceHolder1" runat="server">
    </asp:ContentPlaceHolder>
  </div>
</form>
</body>
</html>

```

Figure 32-9 shows the design-time view of the current master page (note the display area of your AdRotator control will be empty for the time being).

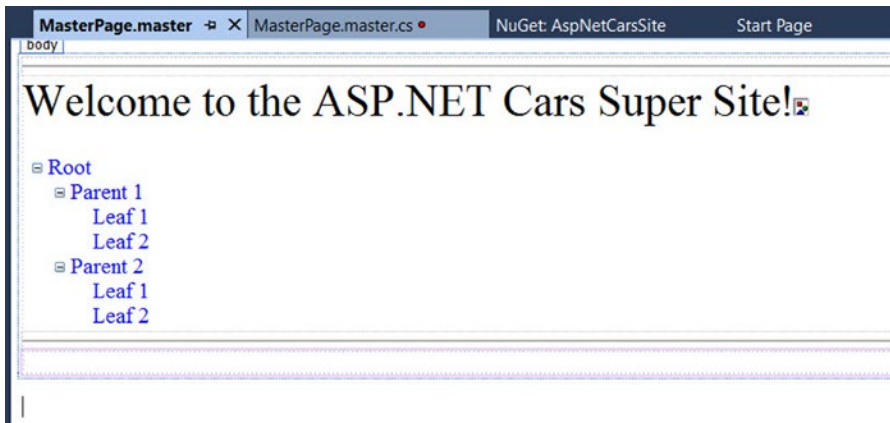

Figure 32-9. The *.master file's shared UI

Feel free to enhance the look of your TreeView control by using the inline editor of the control and selecting the Auto Format link. As well, feel free to spice up the display of the remaining controls using the Properties editor. When you are happy with your results, move to the next section.

Configuring the TreeView Control Site Navigation Logic

Web Forms ships with several web controls that allow you to handle site navigation: `SiteMapPath`, `TreeView`, and `Menu`. As you would expect, these web widgets can be configured in multiple ways. For example, each of these controls can dynamically generate its nodes via an external XML file (or an XML-based `*.sitemap` file), programmatically generate nodes in code, or through markup using the designers of Visual Studio.

Your navigation system will be dynamically populated using a `*.sitemap` file. The benefit of this approach is that you can define the overall structure of your web site in an external file and then bind it to a `TreeView` (or `Menu`) control on the fly. This way, if the navigational structure of your web site changes, you simply need to modify the `*.sitemap` file and reload the page. To begin, insert a new `Web.sitemap` file into your project using the Website ► Add New Item menu option to bring up the dialog box shown in Figure 32-10.

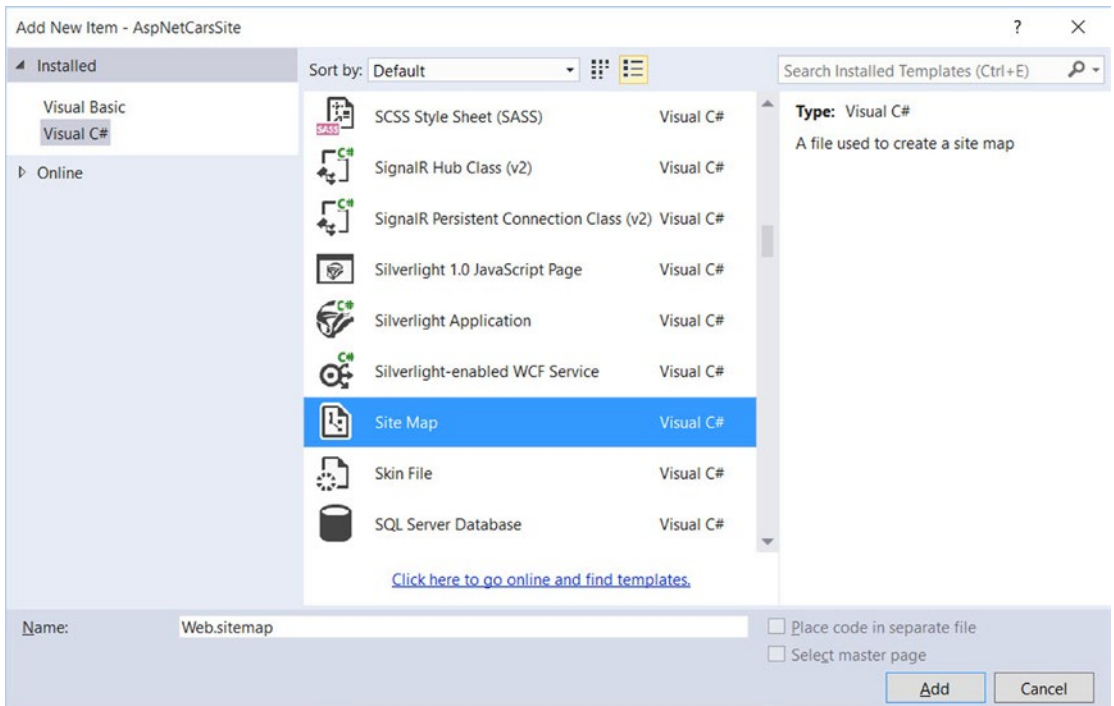

Figure 32-10. Inserting a new `Web.sitemap` file

As you can see, the initial `Web.sitemap` file defines a topmost item with two subnodes, as follows:

```
<?xml version="1.0" encoding="utf-8" ?>
<siteMap xmlns="http://schemas.microsoft.com/AspNet/SiteMap-File-1.0" >
  <siteMapNode url="" title="" description="">
    <siteMapNode url="" title="" description="" />
    <siteMapNode url="" title="" description="" />
  </siteMapNode>
</siteMap>
```

If you were to bind this structure to a Menu control, you would find a topmost item with two subitems. Therefore, when you want to define subitems, simply define new `<siteMapNode>` elements within the scope of an existing `<siteMapNode>`. In any case, the goal is to define the overall structure of your web site within a `Web.sitemap` file using various `<siteMapNode>` elements. Each one of these elements can define a title and URL attribute. The URL attribute represents which `*.aspx` file to navigate to when the user clicks a given menu item (or node of a `TreeView`). Your site map will contain three site map nodes (underneath the top-level site map node), as follows:

- *Home*: `Default.aspx`
- *Build a Car*: `BuildCar.aspx`
- *View Inventory*: `Inventory.aspx`

You will add these three new Web Forms pages to your project in the pages to come. For the time being, you will simply configure the site map file.

Your navigation system has a single topmost `Welcome` item with three subelements. Therefore, you can update the `Web.sitemap` file as follows, but be aware that each `url` value must be unique (if not, you will receive a runtime error):

```
<?xml version="1.0" encoding="utf-8" ?>
<siteMap xmlns="http://schemas.microsoft.com/AspNet/SiteMap-File-1.0" >
  <siteMapNode url="" title="Welcome!" description="">
    <siteMapNode url="~/Default.aspx" title="Home"
      description="The Home Page" />
    <siteMapNode url="~/BuildCar.aspx" title="Build a car"
      description="Create your dream car" />
    <siteMapNode url="~/Inventory.aspx" title="View Inventory"
      description="See what is in stock" />
  </siteMapNode>
</siteMap>
```

Note The `~/` prefix before each page in the `url` attribute is a notation that represents the root of the web site.

Now, despite what you might be thinking, you do not associate a `Web.sitemap` file directly to a `Menu` or `TreeView` control using a given property. Rather, the `*.master` or `*.aspx` file that contains the UI widget that will display the `Web.sitemap` file must contain a `SiteMapDataSource` component. This component will automatically load the `Web.sitemap` file into its object model when the page is requested. The `Menu` and `TreeView` types then set their `DataSourceID` property to point to the `SiteMapDataSource` instance.

To add a new `SiteMapDataSource` to your `*.master` file and automatically set the `DataSourceID` property, you can make use of the Visual Studio designer. Activate the inline editor of the `TreeView` control (i.e., click the tiny arrow in the top-right corner of the `TreeView`), expand the `Choose Data Source` drop-down list, and select `New Data Source`, as shown in Figure 32-11.

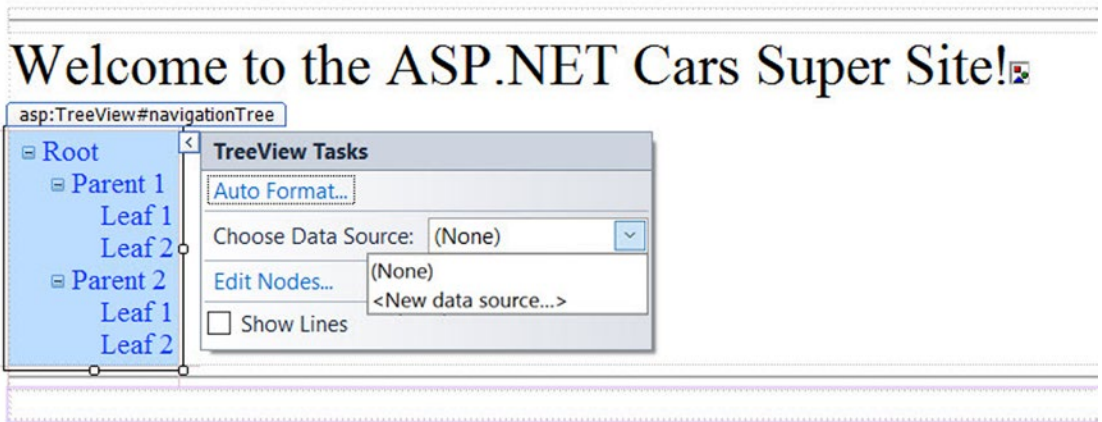

Figure 32-11. Adding a new *SiteMapDataSource*

From the resulting dialog box, select the *SiteMap* icon. This will set the *DataSourceID* property of the Menu or TreeView control, as well as add a new *SiteMapDataSource* component to your page. This is all you need to do to configure your TreeView control to navigate to the additional pages on your site. If you would like to perform additional processing when the user selects a given menu item, you may do so by handling the *SelectedNodeChanged* event on the TreeView control. There is no need to do so for this example, but be aware that you can determine which menu item was selected using the incoming event arguments.

Establishing Breadcrumbs with the *SiteMapPath* Type

Before moving on to the *AdRotator* control, add a *SiteMapPath* type (located in the Navigation tab in the Toolbox) onto your *.master file. This widget will automatically adjust its content based on the current selection of the menu system. As you might know, this can provide a helpful visual cue for the end user (formally, this UI technique is termed *breadcrumbs*). Once you complete this example, you will notice that when you select the Welcome Build a Car menu item, the *SiteMapPath* widget updates accordingly automatically.

Configuring the *AdRotator* Control

The role of the Web Forms *AdRotator* widget is to randomly display a given image at some position in the browser. At this point, the *AdRotator* is displaying an empty placeholder. This control cannot do its magic until you assign the *AdvertisementFile* property to point to the source file that describes each image. For this example, the data source will be a simple XML file named *Ads.xml*.

To add the XML file to the web site, go to the Website Add New Item menu option and select XML file. Name the file *Ads.xml* and specify a unique *<Ad>* element for each image you want to display. At minimum, each *<Ad>* element specifies the image to display (*ImageUrl*), the URL to navigate to if the image is selected (*TargetUrl*), mouseover text (*AlternateText*), and the weight of the ad (*Impressions*).

```

<Advertisements>
  <Ad>
    <ImageUrl>SlugBug.jpg</ImageUrl>
    <TargetUrl>http://www.Cars.com</TargetUrl>
    <AlternateText>Your new Car?</AlternateText>
    <Impressions>80</Impressions>
  </Ad>
  <Ad>
    <ImageUrl>car.gif</ImageUrl>
    <TargetUrl>http://www.CarSuperSite.com</TargetUrl>
    <AlternateText>Like this Car?</AlternateText>
    <Impressions>80</Impressions>
  </Ad>
</Advertisements>

```

Here, you have specified two image files (`slugbug.jpg` and `car.gif`). As a result, you need to ensure that these files are in the root of your web site (these files have been included with this book's code download). To add them to your current project, select the Website Add Existing Item menu option. At this point, you can associate your XML file to the `AdRotator` control via the `AdvertisementFile` property (in the Properties window), like so:

```

<asp:AdRotator ID="myAdRotator" runat="server"
  AdvertisementFile="~/Ads.xml"/>

```

Later, when you run this application and post back to the page, you will be randomly presented with one of two image files.

Defining the Default Content Page

Now that you have a master page established, you can begin designing the individual `*.aspx` pages that will define the UI content to merge within the `<asp:ContentPlaceHolder>` tag of the master page. The `*.aspx` files that are merged within a master page are called *content pages* and have a few key differences from a normal, stand-alone Web Forms page.

In a nutshell, the `*.master` file defines the `<form>` section of the final HTML page. Therefore, the existing `<form>` area within the `*.aspx` file will need to be replaced with an `<asp:Content>` scope. While you could update the markup of your initial `*.aspx` file by hand, you can insert a new content page to your project. First, delete the existing `Default.aspx` file, then right-click anywhere on the designer surface of the `*.master` file and select the Add Content Page menu option (see Figure 32-12).

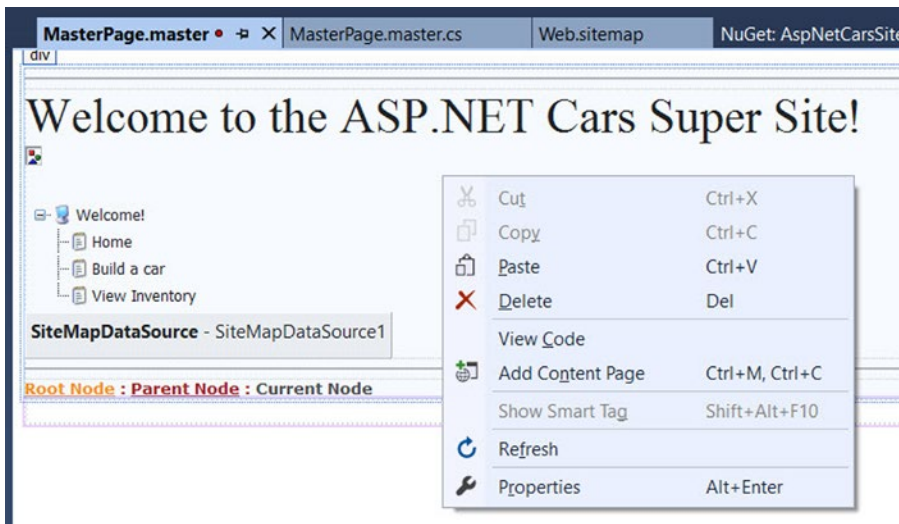

Figure 32-12. Adding a new content page to the master page

This will generate a new *.aspx file with the following initial markup:

```
<%@ Page Language="C#" MasterPageFile="~/MasterPage.master"
    AutoEventWireup="true" CodeFile="Default.aspx.cs"
    Inherits="_Default" Title="" %>

<asp:Content ID="Content1"
    ContentPlaceHolderID="head" Runat="Server">
</asp:Content>
<asp:Content ID="Content2"
    ContentPlaceHolderID="ContentPlaceHolder1" Runat="Server">
</asp:Content>
```

First, notice that the `<%@Page%>` directive has been updated with a new `MasterPageFile` attribute that is assigned to your *.master file. Also note that rather than having a `<form>` element, you have an `<asp:Content>` scope (currently empty) that has set the `ContentPlaceHolderID` value identical to the `<asp:ContentPlaceHolder>` component in the master file.

Given these associations, the content page understands where to plug in its content, while the master's content is displayed in a read-only nature on the content page. There is no need to build a complex UI for your `Default.aspx` content area. For this example, simply add some literal text that provides some basic site instructions, as you see in Figure 32-13 (also notice on the upper right of the content page in the designer that there is a link to switch to the related master file).

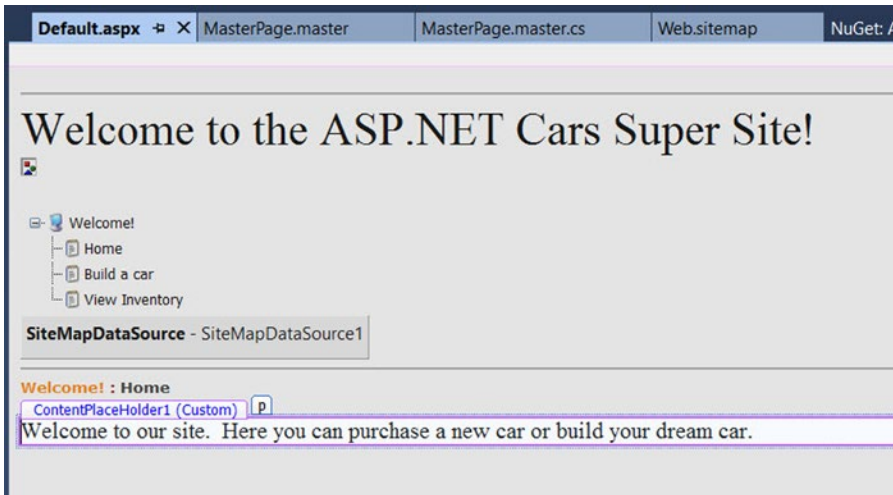

Figure 32-13. Authoring the first content page

Now, if you run your project, you will find that the UI content of the *.master and Default.aspx files has been merged into a single stream of HTML. As you can see from Figure 32-14, the browser (or end user) is unaware that the master page even exists (note the browser is simply showing the HTML from Default.aspx). Also, as you refresh the page (via the F5 key), you should see the AdRotator randomly displaying one of two images.

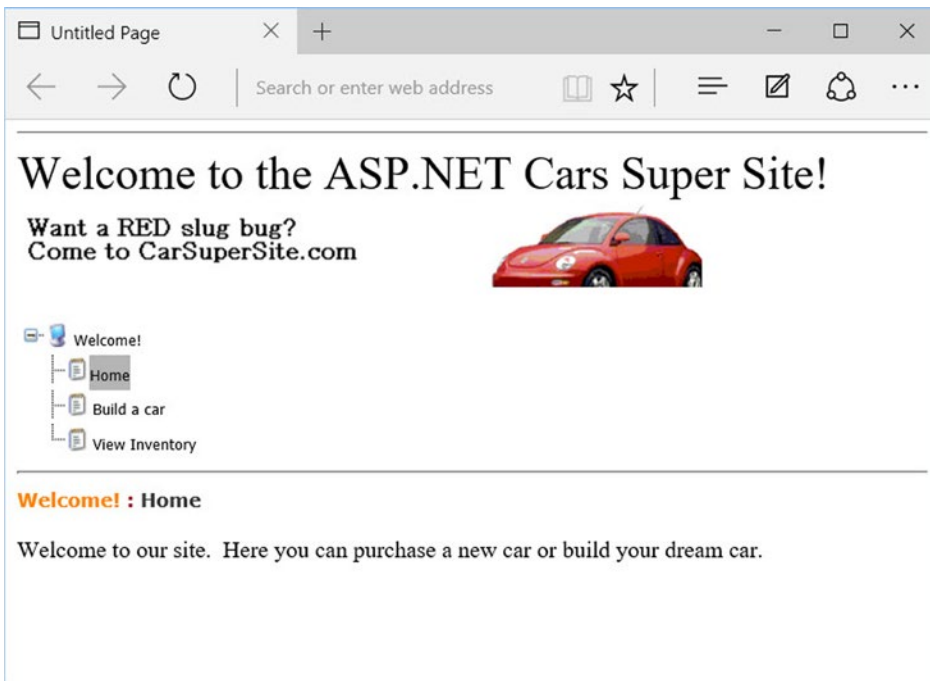

Figure 32-14. At runtime, master files and content pages render back a single form

Designing the Inventory Content Page

To insert the `Inventory.aspx` content page into your current project, open the `*.master` page in the IDE, select `Website Add Content Page`, and use the `Solution Explorer` to rename this file to `Inventory.aspx`. The role of the `Inventory` content page is to display the contents of the `Inventory` table of the `AutoLot` database within a `GridView` control. However, unlike the previous chapter, this `GridView` will be configured to interact with the `AutoLot` database using some built-in data-binding support and the updated `AutoLotDAL` assembly from Chapter 30.

While the `Web Forms GridView` control has the ability to represent connection string data and SQL `Select`, `Update`, and `Delete` statements (or alternatively stored procedures) *in markup*, the preferred method is to use a `Data Access Layer (DAL)`. This promotes separation of concerns and it isolates changes to the data store from the front-end code.

With a few simple attributes and minimal code (presuming you have already built a `DAL`), you can configure the `GridView` to automatically select, update, and delete records of the underlying data store. This greatly simplifies the amount of boilerplate code and is enabled by the `SelectMethod`, `DeleteMethod`, and `UpdateMethod` properties (as well as additional features for list view controls) introduced in `ASP.NET 4.5`.

Adding AutoLotDAL and Entity Framework to AspNetCarsSite

Use `Windows Explorer` to copy the `AutoLotDAL` assembly from Chapter 31 (or from the download directory for this chapter). Add a reference to the `AutoLotDAL` assembly by right-clicking the `references` node in the `AspNetCarsSite` project, clicking `Browse` in the `Add References Dialog`, and navigating to and selecting `AutoLotDAL.dll`.

Next, add `Entity Framework` to the web project by right-clicking the project and selecting `Manage NuGet Packages for Solution`. You will also need to update the `Web.config` file to add the connection string. The change to the `Web.config` file will resemble the following (your connection string might be different based on how you installed `SQL Server Express`):

```
<connectionStrings>
  <add name="AutoLotConnection"
        connectionString="data source=.\SQLEXPRESS2014;initial catalog=AutoLot;integrated
        security=True;MultipleActiveResultSets=True;App=EntityFramework"
        providerName="System.Data.SqlClient"/>
</connectionStrings>
```

Filling the GridView with Data

To illustrate how to work with the GridView in a declarative manner, begin by updating the `Inventory.aspx` content page with a GridView control. Table 32-3 lists the attributes that you will be adding over the next few sections and what each is used for.

Table 32-3. *Select Attributes of List Controls*

| Attribute | Meaning in Life |
|--------------|--|
| DataKeyNames | Specifies the primary key of the table. |
| ItemType | Enables strong typing for list controls. |
| SelectMethod | Indicates the method in the code-behind that is used to fill the table. It is called each time the list control is rendered. |
| DeleteMethod | Indicates the method that will be used to delete a record from the data source for the table. |
| UpdateMethod | Indicates the method that will be used to update a record when the edit is posted back to the server. |

You will start by just using the `ItemType` and `SelectMethod` attributes (as you did in Chapter 31). Update the GridView declaration (in the second `<asp:Content>` element) to the following:

```
<asp:GridView ID="GridView2" runat="server" CellPadding="4" AutoGenerateColumns="False"
  ItemType="AutoLotDAL.Models.Inventory" SelectMethod="GetData"
  EmptyDataText="There are no data records to display." ForeColor="#333333"
  GridLines="None">
```

Next, add the following `Columns` entries (don't mind the `SortExpressions` for now):

```
<Columns>
  <asp:BoundField DataField="CarID" HeaderText="CarID" ReadOnly="True"
    SortExpression="CarID" />
  <asp:BoundField DataField="Make" HeaderText="Make" SortExpression="Make" />
  <asp:BoundField DataField="Color" HeaderText="Color" SortExpression="Color" />
  <asp:BoundField DataField="PetName" HeaderText="PetName" SortExpression="PetName" />
</Columns>
```

Make sure the closing `GridView` tag is after the closing `Columns` tag:

```
</asp:GridView>
```

Open `Inventory.aspx.cs` and add the `GetData` method. The `GetData` method doesn't take any parameters and needs to return an `IEnumerable<Inventory>`. Because you created your DAL already, this becomes trivial. Make sure to add using statements for `AutoLotDAL.Models` and `AutoLotDAL.Repos` and update the `GetData` method as follows:

```
public IEnumerable<Inventory> GetData() => new InventoryRepo().GetAll();
```

At this point, you can run your web program. Click the `View Inventory` menu item and view your data, as shown in Figure 32-15. (Note that I updated my GridView with a unique look and feel using the inline designer.)



Welcome! : View Inventory

Here is our current Inventory!

| CarID | Make | Color | PetName |
|-------|-------|--------|---------|
| 1 | VW1 | Black | Zippy |
| 2 | Ford | Rust | Rusty |
| 3 | Saab | Black | Mel |
| 4 | Yugo | Yellow | Clunker |
| 5 | BMW | Black | Bimmer |
| 6 | BMW | Green | Hank |
| 7 | BMW | Pink | Pinky |
| 13 | Pinto | Black | Pete |

Figure 32-15. The Inventory page with data

Enabling In-Place Editing

The next order of business is to enable the GridView control's support for in-place activation. You will start by using the `DataKeyNames`, `DeleteMethod`, and `UpdateMethod` attributes. Update the GridView declaration markup to the following:

```
<asp:GridView ID="GridView2" runat="server" CellPadding="4" AutoGenerateColumns="False"
  DataKeyNames="CarID, Timestamp" ItemType="AutoLotDAL.Models.Inventory"
  SelectMethod="GetData" DeleteMethod="Delete" UpdateMethod="Update"
  EmptyDataText="There are no data records to display." ForeColor="#333333"
  GridLines="None">
```

The `CarId` is the primary key, so it makes sense to be in the `DataKeyNames` attribute. The `TimeStamp` field is added as a `DataKeyName` so that it will be passed into the `Update` and `Delete` methods. Add the following `CommandField` entry to the `Columns` entries. This will add `Edit` and `Delete` links into each row. The updated markup looks like this:

```
<Columns>
  <asp:CommandField ShowDeleteButton="True" ShowEditButton="True" />
  <asp:BoundField DataField="CarID" HeaderText="CarID" ReadOnly="True"
    SortExpression="CarID" />
  <asp:BoundField DataField="Make" HeaderText="Make" SortExpression="Make" />
  <asp:BoundField DataField="Color" HeaderText="Color" SortExpression="Color" />
  <asp:BoundField DataField="PetName" HeaderText="PetName" SortExpression="PetName" />
</Columns>
```

Open `Inventory.aspx.cs`, and add the `Delete` and `Update` methods. The `Delete` method is `void`, and takes an `int carId` and `byte[] timeStamp` as parameters. Both of those values come into the method as parameters because they are specified as `DataKeyNames` in the markup.

```
public void Delete(int carId, byte[] timeStamp)
{
    new InventoryRepo().Delete(carId, timeStamp);
}
```

The `Update` method is `void` and uses model binding so it can take an `Inventory` type as the parameter. Model binding is a feature of ASP.NET MVC that was ported to ASP.NET WebForms 4.5. It takes all of the form/querystring/etc. name value pairs and attempts to reconstitute a specified type using reflection. There is *explicit model binding* and *implicit model binding*. In each case, the Model Binding engine attempts to assign the values from the name value pairs (from the submitted form) to matching properties on the desired type. If it can't assign one or more values (due to data type conversion issues or validation errors) it will set `ModelState.IsValid = false`. If all matched properties are successfully assigned, it sets `ModelState.IsValid = true`.

For explicit model binding, you call `TryUpdateModel`, passing in an instance of the type. If the model binding fails, the `TryUpdateModel` returns `false`. For example, you could write the `Update` method this way:

```
public async void Update(int carID)
{
    var inv = new Inventory() {CarID = carID};
    if (TryUpdateModel(inv))
    {
        await new InventoryRepo().SaveAsync(inv);
    }
}
```

For implicit model binding, you pass the desired type in as the parameter for the method. Do this for the `Update` method. In the method body, first check to ensure the model state is valid (more on validation later in this chapter), then call `SaveAsync` on the `InventoryRepo`. Since you are awaiting the `SaveAsync` method, add the `async` modifier to the `Update` method, like this:

```
public async void Update(Inventory inventory)
{
    if (ModelState.IsValid)
    {
        await new InventoryRepo().SaveAsync(inv);
    }
}
```

When you add the `async` modifier to the `Update` method you will get an error when the `Update` method gets called because the `Page` is not marked as `async`. Fortunately, that is as easy as adding `Async="true"` to the `Page` directive, like this:

```
<%@ Page Title="" Language="C#" MasterPageFile="~/MasterPage.master"
    AutoEventWireup="true" CodeFile="Inventory.aspx.cs" Inherits="InventoryPage"
    Async="true" %>
```

Now, when you run the app, you will see `Edit` and `Delete` links. Clicking the `Edit` link enables in-place editing, as shown in Figure 32-16. When in edit mode, the links change to `Update` or `Cancel`.

localhost:37076/Inventory.aspx

Welcome to the ASP.NET Cars Super Site!



Want a Blue SLUG BUG?
Come to Cars.com!

- Welcome!
- Home
- Build a car
- View Inventory

Welcome! : View Inventory

Here is our current Inventory!

| | CarID | Make | Color | PetName |
|---|-------|-------|--------|---------|
| Update Cancel | 1 | VW1 | Black | Zippy |
| Edit Delete | 2 | Ford | Rust | Rusty |
| Edit Delete | 3 | Saab | Black | Mel |
| Edit Delete | 4 | Yugo | Yellow | Clunker |
| Edit Delete | 5 | BMW | Black | Bimmer |
| Edit Delete | 6 | BMW | Green | Hank |
| Edit Delete | 7 | BMW | Pink | Pinky |
| Edit Delete | 13 | Pinto | Black | Pete |

Figure 32-16. In-place editing and deleting

Enabling Sorting and Paging

The GridView control can easily be configured for sorting (via column name hyperlinks) and paging (via numeric or next/previous hyperlinks). To do so, update the markup for the GridView, adding in the AllowPaging, PageSize, and AllowSorting attributes as follows:

```
<asp:GridView ID="carsGrid" runat="server"
  AllowPaging="True" PageSize="2"
  AllowSorting="True" AutoGenerateColumns="False" CellPadding="4"
  DataKeyNames="CarID" ItemType="AutoLotDAL.Models.Inventory"
  SelectMethod="GetData" DeleteMethod="Delete" UpdateMethod="Update"
  EmptyDataText="There are no data records to display." ForeColor="#333333"
  GridLines="None">
```

If you run the app now, you will get the following error:

When the DataBoundControl has paging enabled, either the SelectMethod should return an IQueryable<ItemType> or should have all these mandatory parameters: int startIndex, int maximumRows, out int totalRowCount

This is easily fixed by adding AsQueryable() after the GetAll call on the InventoryRepo, and changing the signature for the method to IQueryable, as follows:

```
public IQueryable<Inventory> GetData() => new InventoryRepo().GetAll().AsQueryable();
```

■ **Note** While adding AsQueryable() solved the problem in this example, it would be better to expose an IQueryable version of GetAll on the repository itself.

When you run your page again, you will be able to sort your data by clicking the column names and scrolling through your data via the paging links (provided you have enough records in the Inventory table!), as shown in Figure 32-17.

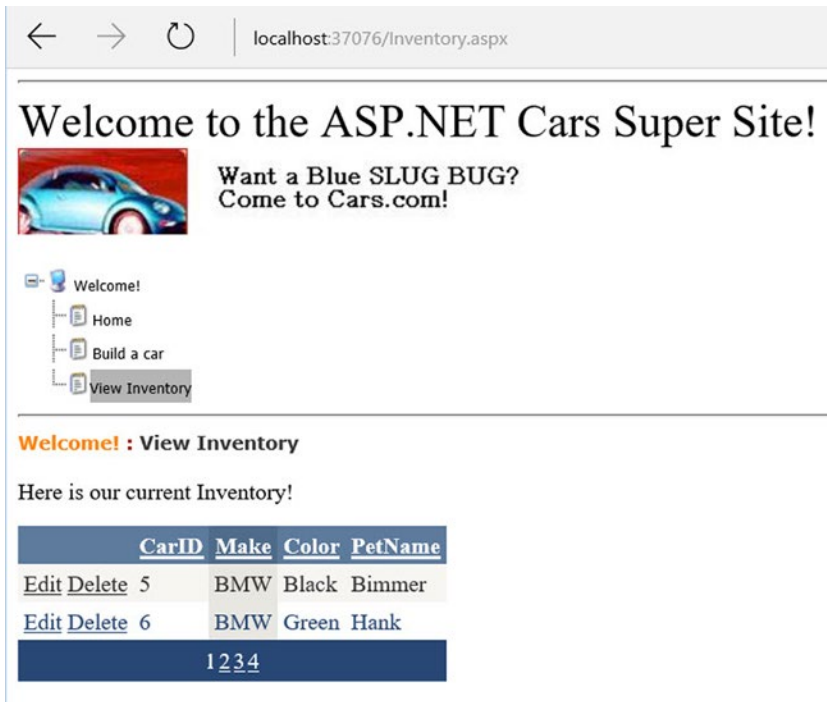

Figure 32-17. Enabling sorting and paging

Enabling Filtering

The next step is to add filtering to the Inventory list. Again, with the additional features added in ASP.NET Web Forms 4.5, this is fairly trivial. Start by adding a DropDownList box that will be bound to the distinct list of Makes in the AutoLot database. The DataTextField (what is displayed) and the DataValueField (the value of the dropdown list based on the selected item) are both set to Make. The SelectMethod should be set to a method named GetMakes. The key is that the control *must* have the `runat=server` setting. Also see the `<asp:ListItem>` tag. This adds the "(All)" selection if nothing from the databound list is selected. The markup is as follows:

```
<asp:DropDownList ID="cboMake" SelectMethod="GetMakes"
  AppendDataBoundItems="true" AutoPostBack="true"
  DataTextField="Make" DataValueField="Make" runat="server">
  <asp:ListItem Value="" Text="(All)" />
</asp:DropDownList>
```

Next, open `Inventory.aspx.cs` and create the `GetMakes` method. In this method, return a list of new anonymous objects that hold the distinct makes from the data. The method is as follows:

```
public IEnumerable GetMakes() =>
  new InventoryRepo().GetAll().Select(x => new {x.Make}).Distinct();
```

The `GetData` method also has to be updated to filter the data if a `Make` is passed in. The parameter is marked with the `[Control("cboMake")]` attribute, specifying the name of the control. The name of the control isn't necessary if the control name matches the parameter name, but since they don't match in this example, you need to specify the control name. This parameter will take the value of the control when the form data is posted back (hence the `runat="server"` requirement) and will be an empty string if nothing is selected. This is done as follows:

```
public IQueryable<Inventory> GetData([Control("cboMake")]string make="")
{
    return string.IsNullOrEmpty(make) ?
        new InventoryRepo().GetAll().AsQueryable() :
        new InventoryRepo().GetAll().Where(x => x.Make == make).AsQueryable();
}
```

Now, when you run the app, you can select a car make, and it will filter the result set based on the selected value, as in Figure 32-18.

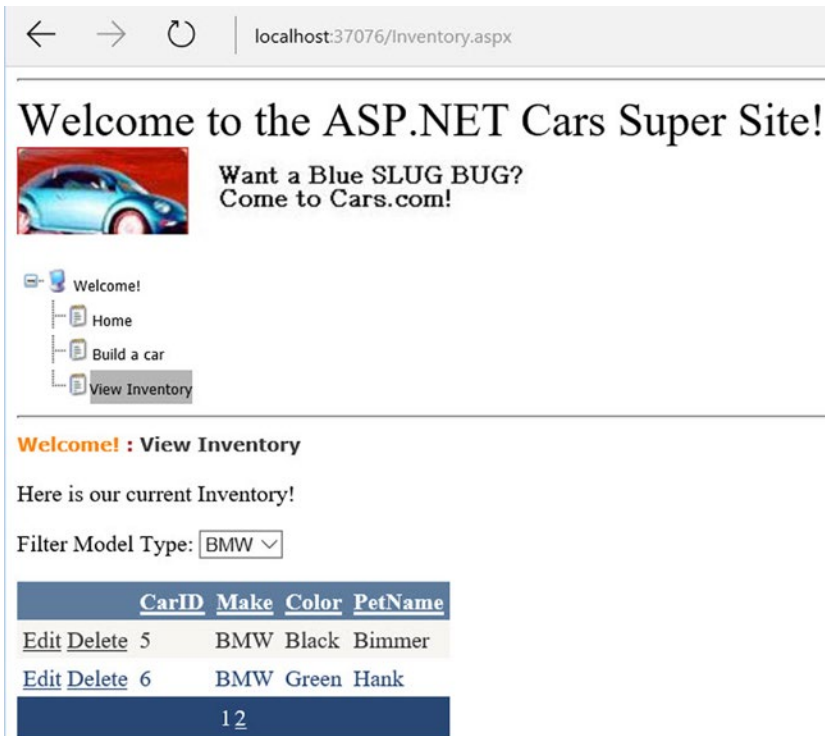

Figure 32-18. Filtering data based on the value of a control on the page

Designing the Build-a-Car Content Page

The final task for this example is to design the `BuildCar.aspx` content page. To do so, make sure you have your `*.master` file open for editing, then insert this file into the current project (via the Website Add Content Page menu option; this is an alternative to right-clicking the project's master page). Rename this new file to `BuildCar.aspx` using the Solution Explorer.

This new page will make use of the Web Forms Wizard web control, which provides a simple way to walk the end user through a series of related steps. Here, the steps in question will simulate the act of building an automobile for purchase.

Place a descriptive `Label` and `Wizard` control onto the content area. Next, activate the inline editor for the `Wizard` and click the `Add/Remove WizardSteps` link. Add a total of four steps, as shown in Figure 32-19.

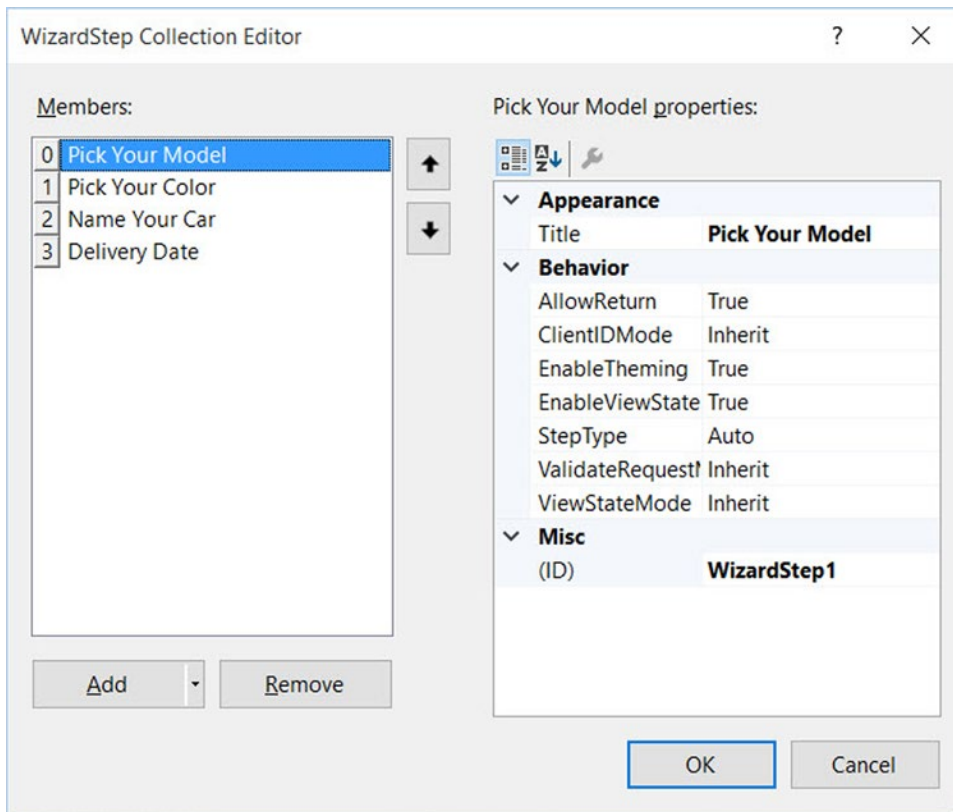

Figure 32-19. Configuring your wizard

After you define these steps, you will notice that the Wizard defines an empty content area where you can now drag and drop controls for the currently selected step. For this example, update each step with the following UI elements (be sure to provide a fitting ID value for each item using the Properties window):

- *Pick Your Model*: A TextBox control
- *Pick Your Color*: A ListBox control
- *Name Your Car*: A TextBox control
- *Delivery Date*: A Calendar control

The ListBox control is the only UI element of the Wizard that requires additional steps. Select this item on the designer (making sure you first select the Pick Your Color link) and fill this widget with a set of colors using the Items property of the Properties window. After you do so, you will find markup much like the following within the scope of the Wizard definition:

```
<asp:ListBox ID="ListBoxColors" runat="server" Width="237px">
  <asp:ListItem>Purple</asp:ListItem>
  <asp:ListItem>Green</asp:ListItem>
  <asp:ListItem>Red</asp:ListItem>
  <asp:ListItem>Yellow</asp:ListItem>
  <asp:ListItem>Pea Soup Green</asp:ListItem>
  <asp:ListItem>Black</asp:ListItem>
  <asp:ListItem>Lime Green</asp:ListItem>
</asp:ListBox>
```

Now that you have defined each of the steps, you can handle the FinishButtonClick event for the autogenerated Finish button. Be aware, however, that you won't see this Finish button until you select the final step of the wizard on the designer. Once you have selected the final step, simply double-click the Finish button to generate the event handler. Within the server-side event handler, obtain the selections from each UI element and build a description string that is assigned to the Text property of an additional Label type named lblOrder, like so:

```
public partial class BuildCarPage : System.Web.UI.Page
{
  protected void Page_Load(object sender, EventArgs e)
  {
  }

  protected void carWizard_FinishButtonClick(object sender,
    WizardNavigationEventArgs e)
  {
    // Get each value.
    string order = $"{txtCarPetName.Text}, your { ListBoxColors.SelectedValue } {
txtCarModel.Text } will arrive on { carCalendar.SelectedDate.ToShortDateString()}";
    // Assign to label.
    lblOrder.Text = order;
  }
}
```

At this point, your AspNetCarsSite web application is complete! Figure 32-20 shows the wizard in action.



Welcome! : Build a car
 Use this Wizard to build
 your Dream Car

| | | | | | | | |
|--|--------------------|----|----|----|----|----------|--------|
| Pick Your Model Pick Your Color Name Your Car Delivery Date | < September 2015 > | | | | | | |
| | Su | Mo | Tu | We | Th | Fr | Sa |
| | 30 | 31 | 1 | 2 | 3 | 4 | 5 |
| | 6 | 7 | 8 | 9 | 10 | 11 | 12 |
| | 13 | 14 | 15 | 16 | 17 | 18 | 19 |
| | 20 | 21 | 22 | 23 | 24 | 25 | 26 |
| | 27 | 28 | 29 | 30 | 1 | 2 | 3 |
| 4 | 5 | 6 | 7 | 8 | 9 | 10 | |
| | | | | | | Previous | Finish |

Barny, your Purple VW will arrive on 9/25/2015.

Figure 32-20. The Wizard control in action

That wraps up your first look of various Web Forms web controls, master pages, content pages, and site map navigation. Next up, let's look at the functionality of the Web Forms validation controls. To keep the topics in this chapter somewhat isolated and atomic, you will build a new web site to illustrate validation techniques; however, you can most certainly add validation controls to your current project.

■ **Source Code** The `AspNetCarsSite` web site is included in the Chapter 32 subdirectory.

The Role of the Validation Controls

The next set of Web Form controls you will examine are known collectively as *validation controls*. Unlike the other Web Form controls you've examined, validation controls are not used to emit HTML for rendering purposes, but are used to emit client-side JavaScript for the purpose of form validation. As illustrated at the beginning of this chapter, client-side form validation is quite useful because you can ensure that various constraints are in place before posting back to the web server, thereby avoiding expensive round trips. Table 32-4 gives a rundown of the Web Forms validation controls.

Table 32-4. *Web Forms Validation Controls*

| Control | Meaning in Life |
|---|--|
| <code>CompareValidator</code> | Validates that the value of an input control is equal to a given value of another input control or a fixed constant. |
| <code>CustomValidator</code> | Allows you to build a custom validation function that validates a given control. |
| <code>RangeValidator</code> | Determines that a given value is in a predetermined range. |
| <code>RegularExpressionValidator</code> | Checks whether the value of the associated input control matches the pattern of a regular expression. |
| <code>RequiredFieldValidator</code> | Ensures that a given input control contains a value (i.e., is not empty). |
| <code>ValidationSummary</code> | Displays a summary of all validation errors of a page in a list, bulleted list, or single-paragraph format. The errors can be displayed inline and/or in a pop-up message box. |

All of the validation controls (minus `ValidationSummary`) ultimately derive from a common base class named `System.Web.UI.WebControls.BaseValidator` and, therefore, they have a set of common features. Table 32-5 documents the key members.

Table 32-5. *Common Properties of the Web Forms Validators*

| Member | Meaning in Life |
|---------------------------------|--|
| <code>ControlToValidate</code> | Gets or sets the input control to validate |
| <code>Display</code> | Gets or sets the display behavior of the error message in a validation control |
| <code>EnableClientScript</code> | Gets or sets a value indicating whether client-side validation is enabled |
| <code>ErrorMessage</code> | Gets or sets the text for the error message |
| <code>ForeColor</code> | Gets or sets the color of the message displayed when validation fails |

To illustrate working with these validation controls, create a new empty web site project named `ValidatorCtrls` and insert a new Web Forms named `Default.aspx`. To begin, place four (well-named) `TextBox` controls (with four corresponding and descriptive `Labels`) onto your page. Next, place a `RequiredFieldValidator`, `RangeValidator`, `RegularExpressionValidator`, and `CompareValidator` control adjacent to each respective input field. Finally, add a single `Button` and a final `Label`. Figure 32-21 shows one possible layout.

The screenshot shows a web browser window with the following content:

- Browser tabs: `Default.aspx`, `ValidationGroups.aspx`, `NuGet: ValidatorCtrls`
- Page title: **Fun with ASP.NET Validators**
- Section: **Required Field:**
 - Text: "Please enter your name" [RequiredFieldValidator1]
- Section: **Range 0 - 100:**
 - Text: [RangeValidator1]
- Section: **Enter your US SSN**
 - Text: [RegularExpressionValidator1]
- Section: **Value < 20**
 - Text: [CompareValidator1]
- Section: **Post back** [lb|ValidationComplete]
- Text: "Here are the things you must correct."
 - Error message 1.
 - Error message 2.

Figure 32-21. Web Forms validation controls will ensure your form data is correct before allowing postback

Now that you have an initial UI to experiment with, let's walk through the process of configuring each validator control and see the end result of doing so. However, first you need to modify the current `web.config` file to allow client-side processing of your validation controls.

Enabling Client-Side JavaScript Validation Support

Beginning with ASP.NET 4.5, Microsoft introduced a new setting to control how validation controls respond at runtime. When you create an ASP.NET web application and open the `web.config` file, you will find the following setting:

```
<appSettings>
  <add key="ValidationSettings:UnobtrusiveValidationMode" value="WebForms" />
</appSettings>
```

When this setting is in your web configuration file, the web site will process validation using various HTML 5 data attributes, rather than sending back blurbs of client-side JavaScript code to be processed by the web browser. Given that this edition of the text does not dive into the details of HTML 5, if you create a Web Forms application (instead of a web site), you need to comment out (or remove) this line in order for the current validation example to work correctly.

The RequiredFieldValidator

Configuring the `RequiredFieldValidator` is straightforward. Simply set the `ErrorMessage` and `ControlToValidate` properties accordingly using the Visual Studio Properties window. Here is the resulting markup that ensures the `txtRequiredField` text box is not empty:

```
<asp:RequiredFieldValidator ID="RequiredFieldValidator1"
  runat="server" ControlToValidate="txtRequiredField"
  ErrorMessage="Oops! Need to enter data.">
</asp:RequiredFieldValidator>
```

The `RequiredFieldValidator` supports an `InitialValue` property. You can use this property to ensure that the user enters any value other than the initial value in the related `TextBox`. For example, when the user first posts to a page, you might want to configure a `TextBox` to contain the value “Please enter your name”. Now, if you did not set the `InitialValue` property of the `RequiredFieldValidator`, the runtime would assume that the string “Please enter your name” is valid. Thus, to ensure a required `TextBox` is valid only when the user enters anything other than “Please enter your name”, configure your widgets as follows:

```
<asp:RequiredFieldValidator ID="RequiredFieldValidator1"
  runat="server" ControlToValidate="txtRequiredField"
  ErrorMessage="Oops! Need to enter data."
  InitialValue="Please enter your name">
</asp:RequiredFieldValidator>
```

The RegularExpressionValidator

The `RegularExpressionValidator` can be used when you want to apply a pattern against the characters entered within a given input field. To ensure that a given `TextBox` contains a valid U.S. Social Security number, you could define the widget as follows:

```
<asp:RegularExpressionValidator ID="RegularExpressionValidator1"
  runat="server" ControlToValidate="txtRegExp"
  ErrorMessage="Please enter a valid US SSN."
  ValidationExpression="\d{3}-\d{2}-\d{4}">
</asp:RegularExpressionValidator>
```

Notice how the `RegularExpressionValidator` defines a `ValidationExpression` property. If you have never worked with regular expressions before, all you need to be aware of for this example is that they are used to match a given string pattern. Here, the expression `"\d{3}-\d{2}-\d{4}"` is capturing a standard U.S. Social Security number of the form xxx-xx-xxxx (where x is any digit).

This particular regular expression is fairly self-explanatory; however, assume you want to test for a valid Japanese phone number. The correct expression now becomes much more complex: `"(0\d{1,4}-|\(\d{1,4}\)?)?\d{1,4}-\d{4}"`. The good news is that when you select the `ValidationExpression` property using the Properties window, you can pick from a predefined set of common regular expressions by clicking the ellipse button.

■ **Note** If you are interested in regular expressions, you will be happy to know that the .NET platform supplies two namespaces (`System.Text.RegularExpressions` and `System.Web.RegularExpressions`) devoted to the programmatic manipulation of such patterns.

The RangeValidator

In addition to a `MinimumValue` and `MaximumValue` property, `RangeValidators` have a property named `Type`. Because you are interested in testing the user-supplied input against a range of whole numbers, you need to specify `Integer` (which is *not* the default!), like so:

```
<asp:RangeValidator ID="RangeValidator1"
  runat="server" ControlToValidate="txtRange"
  ErrorMessage="Please enter value between 0 and 100."

  MaximumValue="100" MinimumValue="0" Type="Integer">
</asp:RangeValidator>
```

The `RangeValidator` can also be used to test whether a given value is between a currency value, date, floating-point number, or string data (the default setting).

The CompareValidator

Finally, notice that the `CompareValidator` supports the following `Operator` property:

```
<asp:CompareValidator ID="CompareValidator1" runat="server"
  ControlToValidate="txtComparison"
  ErrorMessage="Enter a value less than 20." Operator="LessThan"
  ValueToCompare="20" Type="Integer">
</asp:CompareValidator>
```

Given that the role of this validator is to compare the value in the text box against another value using a binary operator, it should be no surprise that the `Operator` property may be set to values such as `LessThan`, `GreaterThan`, `Equal`, and `NotEqual`. Also note that the `ValueToCompare` is used to establish a value to compare against. Note that the `Type` attribute is set to `Integer`. By default, the `CompareValidator` will be testing against string values!

■ **Note** The `CompareValidator` can also be configured to compare a value within another Web Forms control (rather than a hard-coded value) using the `ControlToCompare` property.

To finish up the code for this page, handle the `Click` event for the `Button` control and inform the user that he or she has succeeded in the validation logic, like so:

```
public partial class _Default : System.Web.UI.Page
{
    protected void Page_Load(object sender, EventArgs e)
    {

    }

    protected void btnPostBack_Click(object sender, EventArgs e)
    {
        lblValidationComplete.Text = "You passed validation!";
    }
}
```

Now, navigate to this page using your browser of choice. At this point, you should not see any noticeable changes. However, when you attempt to click the `Submit` button after entering bogus data, your error message is suddenly visible. When you enter valid data, the error messages are removed and postback occurs. If you look at the HTML rendered by the browser, you can see that the validation controls generate a client-side JavaScript function that makes use of a specific library of JavaScript functions that is automatically downloaded to the user's machine. After the validation has occurred, the form data is posted back to the server, where the ASP.NET runtime will perform the same validation tests on the web server (just to ensure that no along-the-wire tampering has taken place).

On a related note, if the HTTP request was sent by a browser that does not support client-side JavaScript, all validation will occur on the server. In this way, you can program against the validation controls without being concerned with the target browser; the returned HTML page redirects the error processing back to the web server.

Creating Validation Summaries

The next validation-centric topic you will examine is the use of the `ValidationSummary` widget. Currently, each of your validators displays its error message at the exact place in which it was positioned at design time. In many cases, this might be exactly what you are looking for. However, on a complex form with numerous input widgets, you might not want to have random blobs of red text pop up. Using the `ValidationSummary` type, you can instruct all of your validation types to display their error messages at a specific location on the page.

The first step is to simply place a `ValidationSummary` on your `*.aspx` file. You may optionally set the `HeaderText` property of this type as well as the `DisplayMode`, which by default will list all error messages as a bulleted list.

```
<asp:ValidationSummary id="ValidationSummary1"
    runat="server" Width="353px"
    HeaderText="Here are the things you must correct.">
</asp:ValidationSummary>
```

Next, you need to set the `Display` property to `None` for each of the individual validators (e.g., `RequiredFieldValidator`, `RangeValidator`) on the page. This will ensure that you do not see duplicate error messages for a given validation failure (one in the summary pane and another at the validator's location). Figure 32-22 shows the summary pane in action.

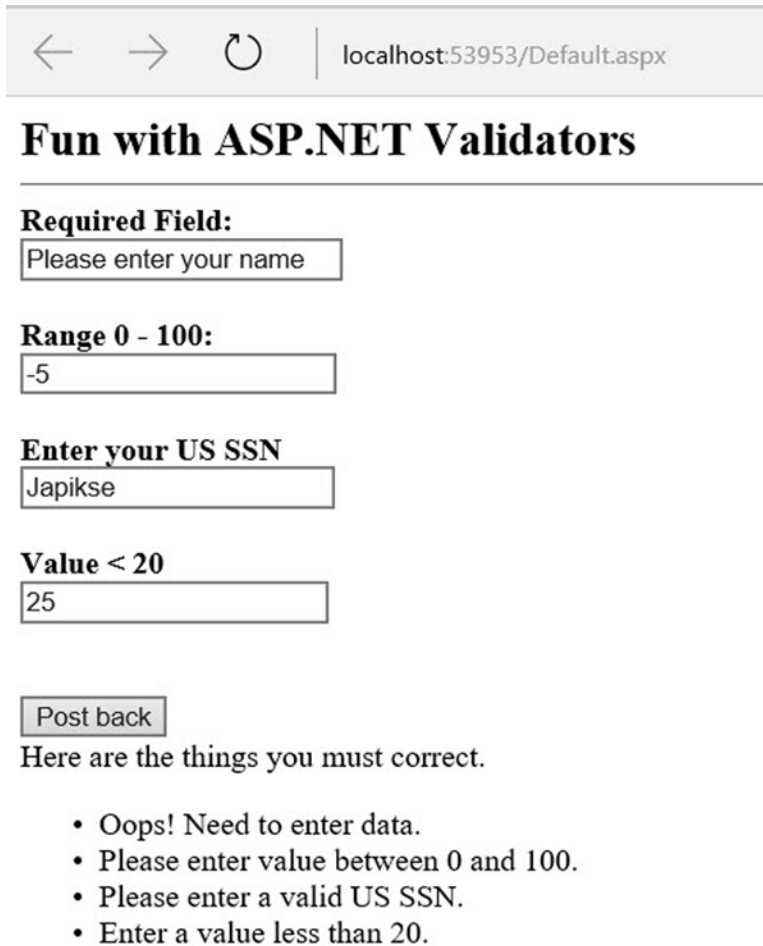

← → ↻ | localhost:53953/Default.aspx

Fun with ASP.NET Validators

Required Field:
Please enter your name

Range 0 - 100:
-5

Enter your US SSN
Japikse

Value < 20
25

Post back

Here are the things you must correct.

- Oops! Need to enter data.
- Please enter value between 0 and 100.
- Please enter a valid US SSN.
- Enter a value less than 20.

Figure 32-22. Using a validation summary

Last but not least, if you would rather have the error messages displayed using a client-side `MessageBox`, set the `ValidationSummary` control's `ShowMessageBox` property to `true` and the `ShowSummary` property to `false`.

Defining Validation Groups

It is also possible to define *groups* for validators to belong to. This can be very helpful when you have regions of a page that work as a collective whole. For example, you could have one group of controls in a Panel object to allow the user to enter his or her mailing address and another Panel containing UI elements to gather credit card information. Using groups, you can configure each group of controls to be validated independently.

Insert a new page into your current project named `ValidationGroups.aspx` that defines two Panels. The first Panel object expects a TextBox to contain some form of user input (via a `RequiredFieldValidator`) and the second Panel expects a U.S. SSN value (via a `RegularExpressionValidator`). Figure 32-23 shows one possible UI.

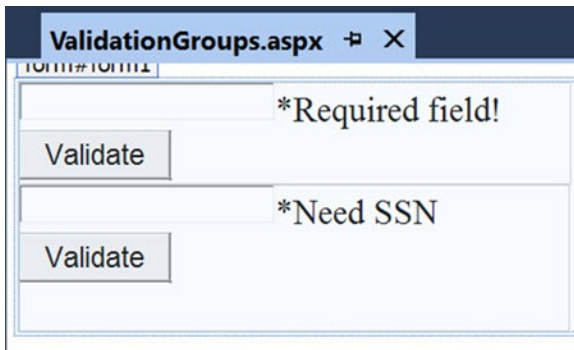

Figure 32-23. These Panel objects will independently configure their input areas

To ensure that the validators function independently, simply assign each validator and the control being validated to a uniquely named group using the `ValidationGroup` property. In the following possible markup, note that the Click event handlers used here are essentially empty stubs in the code file:

```
<form id="form1" runat="server">
  <asp:Panel ID="Panel1" runat="server" Height="83px" Width="296px">
    <asp:TextBox ID="txtRequiredData" runat="server"
      ValidationGroup="FirstGroup">
    </asp:TextBox>
    <asp:RequiredFieldValidator ID="RequiredFieldValidator1" runat="server"
      ErrorMessage="*Required field!" ControlToValidate="txtRequiredData"
      ValidationGroup="FirstGroup">
    </asp:RequiredFieldValidator>
    <asp:Button ID="bntValidateRequired" runat="server"
      OnClick="bntValidateRequired_Click"
      Text="Validate" ValidationGroup="FirstGroup" />
  </asp:Panel>

  <asp:Panel ID="Panel2" runat="server" Height="119px" Width="295px">
    <asp:TextBox ID="txtSSN" runat="server"
      ValidationGroup="SecondGroup">
    </asp:TextBox>
```

```

<asp:RegularExpressionValidator ID="RegularExpressionValidator1"
    runat="server" ControlToValidate="txtSSN"
    ErrorMessage="*Need SSN" ValidationExpression="\d{3}-\d{2}-\d{4}"
    ValidationGroup="SecondGroup">
</asp:RegularExpressionValidator>&nbsp;
<asp:Button ID="btnValidateSSN" runat="server"
    OnClick="btnValidateSSN_Click" Text="Validate"
    ValidationGroup="SecondGroup" />
</asp:Panel>
</form>

```

Now, right-click this page's designer and select the View In Browser menu option to verify that each panel's widgets operate in a mutually exclusive manner.

Validation with Data Annotations

In addition to the validation controls, ASP.NET Web Forms supports validation using Data Annotations. Recall from Chapter 23 that you can mark model classes with attributes that define business requirements for the model (such as Required). Using the new `ModelErrorMessage` control and an additional property on the `ValidationSummary` control, you can present errors resulting from Data Annotation violations with very little code.

Creating the Model

While you could certainly use the `AutoLotDAL` library from Chapter 31, to keep things simple, create a new Inventory class. Start by adding a new `App_Code` directory by right-clicking the project and selecting **Add ► Add ASP.NET Folder ► App_Code**. In this folder, add a new class named `Inventory.cs`. In this class, add the following code (make sure to add a `using` for `System.ComponentModel.DataAnnotations`):

```

public class Inventory
{
    [Key, Required]
    public int CarID { get; set; }

    [Required(ErrorMessage="Make is required.")]
    [StringLength(30, ErrorMessage="Make can only be 30 charaters or less")]
    public string Make { get; set; }

    [Required, StringLength(30)]
    public string Color { get; set; }

    [StringLength(30, ErrorMessage = "Pet Name can only be 30 charaters or less")]
    public string PetName { get; set; }
}

```

Building the User Interface

Next, add a new Web Form named `Annotations.aspx`. In this page, add an `asp:FormView` control inside the `Form` tag. The `FormView` control can switch from display, edit, to insert mode very simply. First, update the header attributes as follows (the `DefaultMode=Insert` loads the `FormView` in Insert mode):

```
<asp:FormView runat="server" ID="fvDataBinding" DataKeyNames="CarID"
  ItemType="Inventory" DefaultMode="Insert" InsertMethod="SaveCar"
  UpdateMethod="UpdateCar" SelectMethod="GetCar">
```

Next, create the `ItemTemplate`. This is the content that will be displayed in read only mode. The `ItemType` strongly types the `FormView`, and allows for the `<%# Item.FieldName %>` syntax. Add the following markup:

```
<ItemTemplate>
  <table style="width:100%">
    <tr>
      <td><asp:Label runat="server" AssociatedControlID="make">Make:</asp:Label></td>
      <td><asp:Label runat="server" ID="make" Text='<%# Item.Make %>' /></td>
    </tr>
    <tr>
      <td><asp:Label runat="server" AssociatedControlID="color">Color:</asp:Label></td>
      <td><asp:Label runat="server" ID="color" Text='<%#: Item.Color %>' /></td>
    </tr>
    <tr>
      <td><asp:Label runat="server" AssociatedControlID="petname">Pet Name:</asp:Label></td>
      <td><asp:Label runat="server" ID="customerAge" Text='<%#: Item.PetName %>' /></td>
    </tr>
    <tr>
      <td colspan="2">
        <asp:Button ID="EditButton" runat="server" CommandName="Edit" Text="Edit" />&nbsp;
      </td>
    </tr>
  </table>
</ItemTemplate>
```

The `CommandName="Edit"` indicates that clicking the button will put the `FormView` into Edit mode. Once in Edit mode, the `EditItemTemplate` is displayed, which you will add next. There are some differences between the syntax for Edit and Display templates. First of all, in Edit templates, instead of using the `<%# Item.FieldName %>` syntax, use `<%# BindItem.FieldName %>`. Using `BindItem` sets up the control for two-way binding. The next difference is the `ModelErrorMessage` control that follows the edit controls. The `ModelErrorMessage` will display any model binding errors for the property identified by the `ModelStateKey`. Note that this is dependent on making the `FormView` strongly typed.

```
<EditItemTemplate>
  <table style="width:100%">
    <tr>
      <td><asp:Label runat="server" AssociatedControlID="make">Make: </asp:Label></td>
      <td>
        <asp:TextBox runat="server" ID="make" Text='<%# BindItem.Make %>' />
        <asp:ModelErrorMessage ModelStateKey="make" runat="server" ForeColor="Red" />
      </td>
    </tr>
  </table>
```

```

    </td>
</tr>
<tr>
  <td><asp:Label runat="server" AssociatedControlID="color">Color: </asp:Label></td>
  <td>
    <asp:TextBox runat="server" ID="color" Text='<%= BindItem.Color %>' />
    <asp:ModelErrorMessage ModelStateKey="color" runat="server" ForeColor="Red" />
  </td>
</tr>
<tr>
  <td><asp:Label runat="server" AssociatedControlID="petname">Pet Name: </asp:Label></td>
  <td>
    <asp:TextBox ID="petname" runat="server" Text='<%= BindItem.PetName %>' />
    <asp:ModelErrorMessage ModelStateKey="petname" runat="server" ForeColor="Red" />
  </td>
</tr>
<tr>
  <td colspan="2">
    <asp:Button runat="server" CommandName="Update" Text="Save" />
    <asp:Button runat="server" CommandName="Cancel" Text="Cancel"
      CausesValidation="false" />
  </td>
</tr>
</table>
</EditItemTemplate>

```

The `InsertItemTemplate` is virtually the same as the `EditItemTemplate`, the only difference (other than the name of the tag) is that the `CommandName` for the `Button` is `Insert`.

```

<InsertItemTemplate>
<table style="width:100%">
  <tr>
    <td><asp:Label runat="server" AssociatedControlID="make">Make: </asp:Label></td>
    <td>
      <asp:TextBox runat="server" ID="make" Text='<%= BindItem.Make %>' />
      <asp:ModelErrorMessage ModelStateKey="make" runat="server" ForeColor="Red" />
    </td>
  </tr>
  <tr>
    <td><asp:Label runat="server" AssociatedControlID="color">Color: </asp:Label></td>
    <td>
      <asp:TextBox runat="server" ID="color" Text='<%= BindItem.Color %>' />
      <asp:ModelErrorMessage ModelStateKey="color" runat="server" ForeColor="Red" />
    </td>
  </tr>
  <tr>
    <td><asp:Label runat="server" AssociatedControlID="petname">Pet Name: </asp:Label></td>
    <td>

```

```

        <asp:TextBox ID="petname" runat="server" Text='<%#: BindItem.PetName %>' />
        <asp:ModelErrorMessage ModelStateKey="petname" runat="server" ForeColor="Red" />
    </td>
</tr>
<tr>
    <td colspan="2">
        <asp:Button runat="server" CommandName="Insert" Text="Save" />
    </td>
</tr>
</table>
</InsertItemTemplate>

```

Finally, close out the FormView:

```
<asp:FormView>
```

Finally, add the ValidationSummary control. The difference here from the earlier examples is setting the ShowModelStateErrors property to true. This instructs the control to show any Model Binding errors. After the closing tag for the FormView, add the following markup:

```

<asp:ValidationSummary runat="server" ShowModelStateErrors="true"
    ForeColor="Red" HeaderText="Please check the following errors:" />

```

Adding the Code

You are going to add just enough code to show the validation. In a real application, your methods to support the FormView would involve calling out to a DAL, and not just tinkering with a local variable. But to keep the example focused, add the following code in Annotations.aspx.cs. You will need to add the Microsoft.CodeDom.Providers.DotNetCompilerPlatform NuGet package to enable the C# 6 features. Note the implicit model binding on the SaveCar method and the explicit model binding on the UpdateCar method.

```

private Inventory _model = null;
public void SaveCar(Inventory car)
{
    if (ModelState.IsValid)
    {
        _model = car;
        //Add new record here
    }
}

public void UpdateCar(int carID)
{
    Inventory car = new Inventory();
    if (TryUpdateModel(car))
    {
        _model = car;
        //Update record here
    }
}

public Inventory GetCar() => _model;

```

Test the App

Now, run the app, and you will see a page similar to Figure 32-24.

The screenshot shows a web browser window with the address bar displaying 'localhost:53953/Annotations.aspx'. Below the address bar, there are three input fields labeled 'Make:', 'Color:', and 'Pet Name:'. Each field is empty. Below the 'Pet Name:' field is a 'Save' button.

Figure 32-24. The *FormView* control in Insert mode

Leave the Make and Color blank, and add a Pet Name longer than 30 characters, and click Save. You should see the same errors as in Figure 32-25.

The screenshot shows the same web browser window as Figure 32-24, but now with error messages. The 'Make' field has the error 'Make is required.' The 'Color' field has the error 'The Color field is required.' The 'Pet Name' field has the error 'Pet Name can only be 30 charaters or less'. Below the form, there is a 'Save' button and a red heading 'Please check the following errors:' followed by a bulleted list of the three error messages.

Figure 32-25. The *FormView* control with errors showing

As with the other Web Forms controls, both the *ModelErrorMessage* and *ValidationSummary* controls can be styled much better than what I have done here.

■ **Source Code** The *ValidatorCtrls* web site is included in the Chapter 32 subdirectory.

Working with Themes

At this point, you have worked with numerous Web Forms web controls. As you have seen, each control exposes a set of properties (many of which are inherited by `System.Web.UI.WebControls.WebControl`) that allow you to establish a given UI look and feel (background color, font size, border style, and whatnot). Of course, on a multipage web site, it is quite common for the site as a whole to define a common look and feel for various types of widgets. For example, all `TextBoxes` could be configured to support a given font, all `Buttons` to have a custom image, and all `Calendars` to have a light blue border.

Obviously, it would be very labor intensive (and error prone) to establish the *same* property settings for *every* widget on *every* page within your web site. Even if you were able to manually update the properties of each UI widget on each page, imagine how painful it would be when you needed to change the background color for each `TextBox` yet again. Clearly, there must be a better way to apply site-wide UI settings.

One approach to simplifying the application of a common UI look and feel is to define *style sheets*. If you have a background in web development, you are aware that style sheets define a common set of UI-centric settings that are applied on the browser. As you would hope, Web Forms web controls can be assigned a given style by assigning the `CssStyle` property.

However, Web Forms ships with a complementary technology to define a common UI termed *themes*. Unlike a style sheet, themes are applied on the web server (rather than the browser) and can be done programmatically or declaratively. Given that a theme is applied on the web server, it has access to all the server-side resources on the web site. Furthermore, themes are defined by authoring the same markup you would find within any `*.aspx` file (as you might agree, the syntax of a style sheet is a bit on the terse side).

Recall from Chapter 31 that ASP.NET web applications may define any number of special subdirectories, one of which is `App_Themes`. This single subdirectory may be further partitioned with additional subdirectories, each of which represents a possible theme on your site. For example, consider Figure 32-26, which illustrates a single `App_Themes` folder containing three subdirectories, each of which has a set of files that make up the theme itself.



Figure 32-26. A single `App_Theme` folder may define numerous themes

Understanding *.skin Files

The one file that every theme subdirectory is sure to have is a `*.skin` file. These files define the look and feel for various web controls. To illustrate, create a new empty web site named `FunWithThemes`, and insert a new `Default.aspx` Web Form. On this new page, add a `Calendar`, `TextBox`, and `Button` control. You don't need to configure these controls in any special way, and the names of these controls are irrelevant for the current example. As you will see, these controls will be the targets for your custom skins.

Next, insert a new `*.skin` file (using the Website Add New Item menu option) named `BasicGreen.skin`, as shown in Figure 32-27.

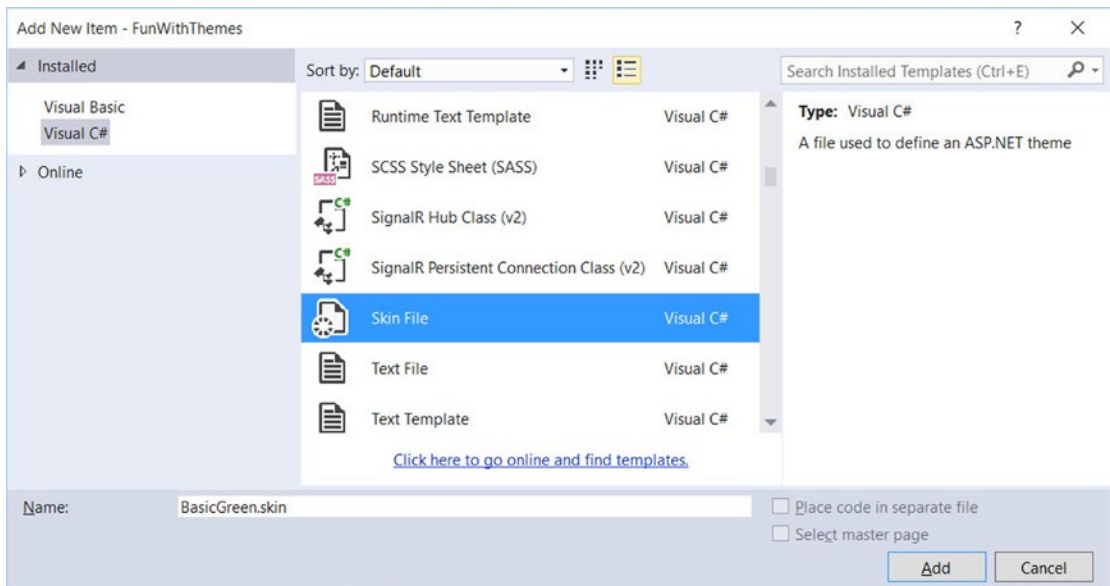

Figure 32-27. Inserting *.skin files

Visual Studio will prompt you to confirm that this file can be added into an `App_Themes` folder (which is exactly what you want). If you look in your Solution Explorer, you will indeed find that your `App_Themes` folder has a subfolder named `BasicGreen` containing your new `BasicGreen.skin` file.

A *.skin file is where you can define the look and feel of various widgets using Web Forms control declaration syntax. Sadly, the IDE does not provide designer support for *.skin files. One way to reduce the amount of typing time is to insert a temporary *.aspx file into your program (`temp.aspx`, for example) that can be used to build up the UI of the widgets using the Visual Studio page designer.

The resulting markup can then be copied and pasted into your *.skin file. When you do so, however, you *must* delete the ID attribute for each web control! This should make sense, given that you are not trying to define a UI look and feel for a *particular* Button (for example), but rather *all* Buttons.

This being said, here is the markup for `BasicGreen.skin` that defines a default look and feel for the Button, TextBox, and Calendar types:

```
<asp:Button runat="server" BackColor="#80FF80"/>
<asp:TextBox runat="server" BackColor="#80FF80"/>
<asp:Calendar runat="server" BackColor="#80FF80"/>
```

Notice that each widget still has the `runat="server"` attribute (which is mandatory), and none of the widgets have been assigned an ID attribute.

Now, let's define a second theme named `CrazyOrange`. Using the Solution Explorer, right-click your `App_Themes` folder and add a new theme named `CrazyOrange`. This will create a new subdirectory under your site's `App_Themes` folder.

Next, right-click the new CrazyOrange folder within the Solution Explorer and select Add New Item. From the resulting dialog box, add a new *.skin file. Update the CrazyOrange.skin file to define a unique UI look and feel for the same web controls, like so:

```
<asp:Button runat="server" BackColor="#FF8000" />
<asp:TextBox runat="server" BackColor="#FF8000" />
<asp:Calendar BackColor="White" BorderColor="Black"
  BorderStyle="Solid" CellSpacing="1"
  Font-Names="Verdana" Font-Size="9pt" ForeColor="Black" Height="250px"
  NextPrevFormat="ShortMonth" Width="330px" runat="server">
  <SelectedDayStyle BackColor="#333399" ForeColor="White" />
  <OtherMonthDayStyle ForeColor="#999999" />
  <TodayDayStyle BackColor="#999999" ForeColor="White" />
  <DayStyle BackColor="#CCCCCC" />
  <NextPrevStyle Font-Bold="True" Font-Size="8pt" ForeColor="White" />
  <DayHeaderStyle Font-Bold="True" Font-Size="8pt"
    ForeColor="#333333" Height="8pt" />
  <TitleStyle BackColor="#333399" BorderStyle="Solid"
    Font-Bold="True" Font-Size="12pt"
    ForeColor="White" Height="12pt" />
</asp:Calendar>
```

At this point, your Solution Explorer should look like Figure 32-28.

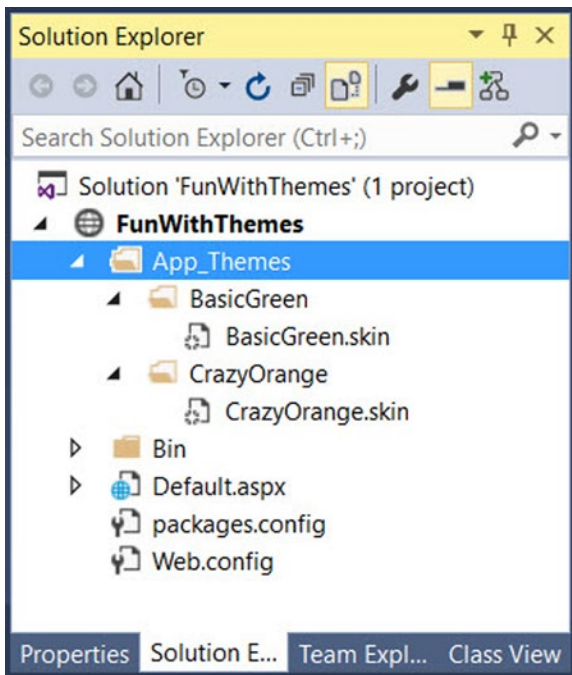

Figure 32-28. A single web site with multiple themes

Now that your site has a few themes defined, the next logical step is to apply them to your pages. As you might guess, there are many ways to do so.

■ **Note** These example themes are quite bland by design (in order to reduce the amount of markup on the printed page). Feel free to spruce things up to your liking.

Applying Site-Wide Themes

If you want to make sure that every page in your site adheres to the same theme, the simplest way to do so is to update your `web.config` file. Open your current `web.config` file and define a `<pages>` element within the scope of your `<system.web>` root element. If you add a theme attribute to the `<pages>` element, this will ensure that every page in your web site is assigned the selected theme (which is, of course, the name of one of the subdirectories under `App_Theme`). Here is the critical update:

```
<configuration>
  <system.web>
    ...
    <pages controlRenderingCompatibilityVersion="4.5"
          theme="BasicGreen">
    </pages>
  </system.web>
</configuration>
```

If you run this page, you will find that each widget has the UI of `BasicGreen`. If you update the theme attribute to `CrazyOrange` and run the page again, you will find the UI defined by this theme is used instead.

Applying Themes at the Page Level

It is also possible to assign themes on a page-by-page level. This can be helpful in a variety of circumstances. For example, perhaps your `web.config` file defines a site-wide theme (as described in the previous section) but you want to assign a different theme to a specific page. To do so, you can simply update the `<%@Page%>` directive. If you are using Visual Studio to do so, you will be happy to find that IntelliSense will display each defined theme within your `App_Theme` folder.

```
<%@ Page Language="C#" AutoEventWireup="true"
  CodeFile="Default.aspx.cs" Inherits="_Default" Theme ="CrazyOrange" %>
```

Because you assigned the `CrazyOrange` theme to this page, but the `web.config` file specified the `BasicGreen` theme, all pages *but this page* will be rendered using `BasicGreen`.

The SkinID Property

Sometimes you might need to define a set of possible UI look-and-feel scenarios for a single widget. For example, assume you want to define two possible UIs for the `Button` type within the `CrazyOrange` theme. You may differentiate each look and feel using the `SkinID` property of a control within the `*.skin` file:

```
<asp:Button runat="server" BackColor="#FF8000"/>
<asp:Button runat="server" SkinID = "BigFontButton"
    Font-Size="30pt" BackColor="#FF8000"/>
```

Now, if you have a page that makes use of the `CrazyOrange` theme, each `Button` will, by default, be assigned the unnamed `Button` skin. If you want to have various buttons within the `*.aspx` file make use of the `BigFontButton` skin, simply specify the `SkinID` property within the markup, like so:

```
<asp:Button ID="Button2" runat="server"
    SkinID="BigFontButton" Text="Button" /><br />
```

Assigning Themes Programmatically

Last but not least, it is possible to assign a theme in code. This can be helpful when you want to provide a way for end users to select a theme for their current session. Of course, I have not yet shown you how to build stateful web applications, so the current theme selection will be forgotten between postbacks. In a production-level site, you might want to store the user's current theme selection within a session variable, or persist the theme selection to a database.

To illustrate how to assign a theme programmatically, update the UI of your `Default.aspx` file with three new `Button` controls, as shown in [Figure 32-29](#). After you have done so, handle the `Click` event for each `Button`.

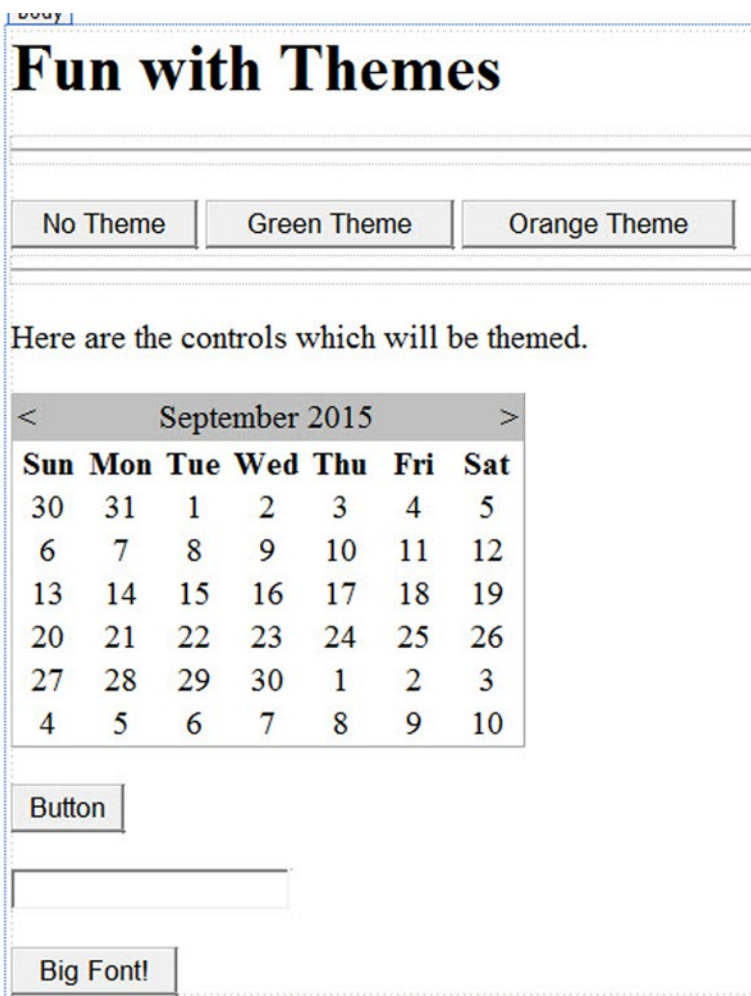

Figure 32-29. The updated UI of the themes example

Now, be aware that you can only assign a theme programmatically during specific phases of your page's life cycle. Typically, this will be done within the `Page_PreInit` event. This being said, update your code file as follows:

```
partial class _Default : System.Web.UI.Page
{
    protected void btnNoTheme_Click(object sender, System.EventArgs e)
    {
        // Empty strings result in no theme being applied.
        Session["UserTheme"] = "";
    }
}
```

```

    // Triggers the PreInit event again.
    Server.Transfer(Request.FilePath);
}

protected void btnGreenTheme_Click(object sender, System.EventArgs e)
{
    Session["UserTheme"] = "BasicGreen";

    // Triggers the PreInit event again.
    Server.Transfer(Request.FilePath);
}

protected void btnOrangeTheme_Click(object sender, System.EventArgs e)
{
    Session["UserTheme"] = "CrazyOrange";

    // Triggers the PreInit event again.
    Server.Transfer(Request.FilePath);
}

protected void Page_PreInit(object sender, System.EventArgs e)
{
    try
    {
        Theme = Session["UserTheme"].ToString();
    }
    catch
    {
        Theme = "";
    }
}
}

```

Notice that you are storing the selected theme within a session variable (see Chapter 33 for details) named `UserTheme`, which is formally assigned within the `Page_PreInit()` event handler. Also note that when the user clicks a given `Button`, you programmatically force the `PreInit` event to fire by calling `Server.Transfer()` and requesting the current page once again. If you run this page, you will find that you can establish your theme via various `Button` clicks.

■ **Source Code** The `FunWithThemes` web site is included in the [Chapter 32](#) subdirectory.

Summary

This chapter examined how to make use of various Web Forms web controls. You began by examining the role of the `Control` and `WebControl` base classes, and you learned how to dynamically interact with a panel's internal controls collection. Along the way, you were exposed to the new site navigation model (`*.sitemap` files and the `SiteMapDataSource` component), the new data-binding engine, and various validation controls.

The latter half of this chapter examined the role of master pages and themes. Recall that master pages can be used to define a common layout for a set of pages on your site. Also recall that the `*.master` file defines any number of content placeholders into which content pages plug their custom UI content. Finally, as you were shown, the Web Forms theme engine allows you to declaratively or programmatically apply a common UI look and feel to your widgets on the web server.

CHAPTER 33



ASP.NET State Management Techniques

The previous two chapters concentrated on the composition and behavior of ASP.NET pages and the web controls they contain. This chapter builds on that information by examining the role of the `Global.asax` file and the underlying `HttpApplication` type. As you will see, the functionality of `HttpApplication` allows you to intercept numerous events that enable you to treat your web application as a cohesive unit, rather than a set of stand-alone `*.aspx` files driven by a master page.

In addition to investigating the `HttpApplication` type, this chapter also addresses the all-important topic of state management. Here you will learn the role of the view state, session, and application variables (including the application cache), cookie data, and the ASP.NET Profile API.

The Issue of State

At the beginning of Chapter 31, I pointed out that HTTP on the Web results in a *stateless* wire protocol. This very fact makes web development extremely different from the process of building an executable assembly. For example, when you are building a Windows desktop UI application, you can rest assured that any member variables defined in the Form-derived class will typically exist in memory until the user explicitly shuts down the executable.

```
public partial class MainWindow : Window
{
    // State data!
    private string userFavoriteCar = "Yugo";
}
```

In the World Wide Web environment, however, you are not afforded the same luxurious assumption. To prove the point, create a new Empty Web Site project named SimpleStateExample and insert a new Web Form. In the code-behind file of your *.aspx file, define a page-level string variable named userFavoriteCar, as follows:

```
public partial class _Default : System.Web.UI.Page
{
    // State data?
    private string userFavoriteCar = "Yugo";

    protected void Page_Load(object sender, EventArgs e)
    {
    }
}
```

Next, construct a very simple web UI, as shown in Figure 33-1.

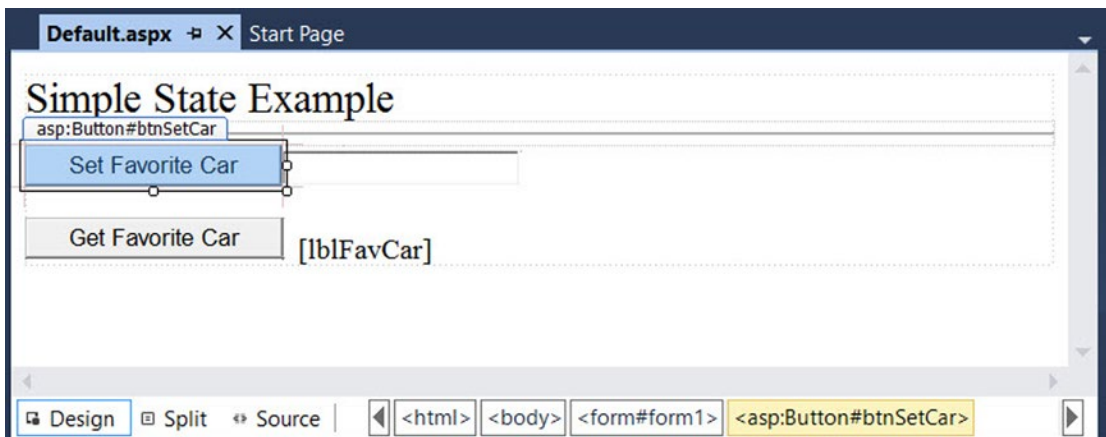

Figure 33-1. The UI for the simple state page

The server-side Click event handler for the Set button (named btnSetCar) allows the user to assign the string member variable to the value within the TextBox (named txtFavCar), like so:

```
protected void btnSetCar_Click(object sender, EventArgs e)
{
    // Store favorite car in member variable.
    userFavoriteCar = txtFavCar.Text;
}
```

The Click event handler for the Get button (btnGetCar) displays the current value of the member variable within the page's Label widget (lblFavCar), as follows:

```
protected void btnGetCar_Click(object sender, EventArgs e)
{
    // Show value of member variable.
    lblFavCar.Text = userFavoriteCar;
}
```

If you were building a Windows GUI application, you would be right to assume that once the user sets the initial value, it will be remembered throughout the life of the desktop application. Sadly, when you run this web application, you will find that each time you post back to the web server (by clicking either button), the value of the `userFavoriteCar` string variable is set back to the initial value of “Yugo.” Therefore, the `Label`’s text is continuously fixed.

Again, given that HTTP has no clue how to automatically remember data once the HTTP response has been sent, it stands to reason that the `Page` object is destroyed almost instantly. As a result, when the client posts back to the `*.aspx` file, a new `Page` object is constructed that will reset any page-level member variables. This is clearly a major issue. Imagine how useless online shopping would be if every time you posted back to the web server, any and all information you previously entered (such as the items you wished to purchase) were discarded. When you want to remember information regarding the users who are logged on to your site, you need to make use of various state management techniques.

■ **Note** This issue is in no way limited to ASP.NET. Java web applications, CGI applications, classic ASP applications, and PHP applications all must contend with the thorny issue of state management.

To remember the value of the `userFavoriteCar` string type between postbacks, one approach is to store the value of this string type in a *session variable*. You will examine the details of session state in the pages that follow. For the sake of completion, however, here are the necessary updates for the current page (note that you are no longer using the private `string` member variable, so feel free to comment out or remove the definition altogether):

```
public partial class _Default : System.Web.UI.Page
{
    // State data?
    // private string userFavoriteCar = "Yugo";

    protected void Page_Load(object sender, EventArgs e)
    {
    }

    protected void btnSetCar_Click(object sender, EventArgs e)
    {
        // Store value to be remembered in session variable.
        Session["UserFavCar"] = txtFavCar.Text;
    }

    protected void btnGetCar_Click(object sender, EventArgs e)
    {
        // Get session variable value.
        lblFavCar.Text = (string)Session["UserFavCar"];
    }
}
```

If you now run the application, the value of your favorite automobile will be preserved across postbacks, thanks to the `HttpSessionState` object manipulated indirectly by the inherited `Session` property. Session data (which will be examined in greater detail later in this chapter) is just one way to “remember” information in your web sites. Over the next several pages, you will examine each of the major options supported by ASP.NET.

■ **Source Code** The SimpleStateExample web site is included in the Chapter 33 subdirectory.

ASP.NET State Management Techniques

ASP.NET provides several mechanisms you can use to maintain stateful information in your web applications. Here are some common options:

- Use ASP.NET view state.
- Use ASP.NET control state.
- Define application-level data.
- Use the cache object.
- Define session-level data.
- Define cookie data.

In addition to these techniques, if you want to persist user data in a permanent manner, ASP.NET provides an out-of-the-box Profile API. You'll examine the details of each approach in turn, beginning with the topic of ASP.NET view state.

Understanding the Role of ASP.NET View State

The term *view state* has been thrown out a few times here and in the previous chapters without a formal definition, so let's demystify this term. Without framework support, web developers are required to manually repopulate the values of the incoming form widgets during the process of constructing the outgoing HTTP response.

Using ASP.NET, we no longer have to manually scrape out and repopulate the values in the HTML widgets because the ASP.NET runtime automatically embeds a hidden form field (named `__VIEWSTATE`), which will flow between the browser and a specific page. The data assigned to this field is a Base64-encoded string that contains a set of name/value pairs representing the values of each GUI widget on the page at hand.

The `System.Web.UI.Page` base class's `Init` event handler is the entity in charge of reading the incoming values in the `__VIEWSTATE` field to populate the appropriate member variables in the derived class. (This is why it is risky at best to access the state of a web widget within the scope of a page's `Init` event handler.)

Also, just before the outgoing response is emitted back to the requesting browser, the `__VIEWSTATE` data is used to repopulate the form's widgets. Clearly, the best thing about this aspect of ASP.NET is that it just happens without any work on your part. Of course, you are always able to interact with, alter, or disable this default functionality if you so choose. To understand how to do this, let's see a concrete view state example.

Demonstrating View State

First, create a new Empty Web Site called `ViewStateApp` and insert a new Web Form named `Default.aspx`. Right-click the project name, and select `Manage NuGet Packages`. Add the `Microsoft.CodeDom.Providers.DotNetCompilerPlatform` NuGet package, which provides C# 6 features for your web site. On your `*.aspx` page, add a single ASP.NET `ListBox` web control named `myListBox` and a single `Button` control named `btnPostBack`.

■ **Note** For all of the examples in this chapter, you will need to add the `Microsoft.CodeDom.Providers.DotNetCompilerPlatform` NuGet package to support the C# 6 features.

Now, using the Visual Studio Properties window, access the `Items` property and add four `ListItems` to the `ListBox` using the associated dialog box. The resulting markup should look something like this:

```
<asp:ListBox ID="myListBox" runat="server">
  <asp:ListItem>Item One</asp:ListItem>
  <asp:ListItem>Item Two</asp:ListItem>
  <asp:ListItem>Item Three</asp:ListItem>
  <asp:ListItem>Item Four</asp:ListItem>
</asp:ListBox>
```

Note that you are hard-coding the items in the `ListBox` directly within the `*.aspx` file. As you already know, all `<asp:>` definitions in an ASP.NET Web Form will automatically render back their HTML representation before the final HTTP response (provided they have the `runat="server"` attribute).

The `<%@Page%>` directive has an optional attribute called `EnableViewState` that by default is set to `true`. To disable this behavior, simply update the `<%@Page%>` directive as follows:

```
<%@ Page Language="C#" AutoEventWireup="true"
  CodeFile="Default.aspx.cs" Inherits="_Default"
  EnableViewState = "false" %>
```

So, what exactly does it mean to disable view state? The answer is, it depends. Given the previous definition of the term, you would think that if you disable view state for an `*.aspx` file, the values in your `ListBox` would not be remembered between postbacks to the web server. However, if you were to run this application as is, you might be surprised to find that the information in the `ListBox` is retained regardless of how many times you post back to the page.

In fact, if you examine the source HTML returned to the browser (by right-clicking the page within the browser and selecting `View Source`), you might be further surprised to see that the hidden `__VIEWSTATE` field is *still present*.

```
<input type="hidden" name="__VIEWSTATE" id="__VIEWSTATE"
  value="/wEPDwUKLTm4MTM2MDM4NGRkqGC6gjEV25JnddkJiRmoIc10SIA=" />
```

However, assume that your `ListBox` is dynamically populated within the code-behind file rather than within the HTML `<form>` definition. First, remove the `<asp:ListItem>` declarations from the current `*.aspx` file.

```
<asp:ListBox ID="myListBox" runat="server">
</asp:ListBox>
```

Next, fill the list items within the Load event handler in your code-behind file, like so:

```
protected void Page_Load(object sender, EventArgs e)
{
    if (!IsPostBack)
    {
        // Fill ListBox dynamically!
        myListBox.Items.Add("Item One");
        myListBox.Items.Add("Item Two");
        myListBox.Items.Add("Item Three");
        myListBox.Items.Add("Item Four");
    }
}
```

If you post to this updated page, you'll find that the first time the browser requests the page, the values in the `ListBox` are present and accounted for. However, on postback, the `ListBox` is suddenly empty. The first rule of the ASP.NET view state is that its effect is only realized when you have widgets whose values are dynamically generated through code. If you hard-code values within the *.aspx file's `<form>` tags, the state of these items is always remembered across postbacks (even when you set `EnableViewState` to `false` for a given page).

If the idea of disabling view state for the entire *.aspx file seems a bit too aggressive, know that every descendant of the `System.Web.UI.Control` base class inherits the `EnableViewState` property, which makes it very simple to disable view state on a control-by-control basis.

```
<asp:GridView id="myHugeDynamicallyFilledGridOfData" runat="server"
    EnableViewState="false">
</asp:GridView>
```

■ **Note** Beginning with .NET 4.0, large view state data values are automatically compressed to help reduce the size of this hidden form field.

Adding Custom View State Data

In addition to the `EnableViewState` property, the `System.Web.UI.Control` base class provides a protected property named `ViewState`. Under the hood, this property provides access to a `System.Web.UI.StateBag` type, which represents all the data contained within the `__VIEWSTATE` field. Using the indexer of the `StateBag` type, you can embed custom information within the hidden `VIEWSTATE` form field using a set of name/value pairs. Here's a simple example:

```
protected void btnAddToVS_Click(object sender, EventArgs e)
{
    ViewState["CustomViewStateItem"] = "Some user data";
    lblVSValue.Text = (string)ViewState["CustomViewStateItem"];
}
```

Because the `System.Web.UI.StateBag` type has been designed to operate on `System.Object` types, when you want to access the value of a given key, you should explicitly cast it into the correct underlying data type (in this case, a `System.String`). Be aware, however, that values placed within the `__VIEWSTATE` field cannot be just any object. Specifically, the only valid types are `Strings`, `Integers`, `Booleans`, `ArrayLists`, `Hashtables`, or an array of these types.

So, given that `*.aspx` pages can insert custom bits of information into the `__VIEWSTATE` string, the next logical step is to figure out when you would want to do so. Most of the time, custom view-state data is best suited for user-specific preferences. For example, you could establish view-state data that specifies how a user wants to view the UI of a `GridView` (such as a sort order). However, view-state data is not well-suited for full-blown user data, such as items in a shopping cart or cached `DataSets`. When you need to store this sort of complex information, you must work with session or application data. Before you get to that point, though, you need to understand the role of the `Global.asax` file.

■ **Source Code** The `ViewStateApp` web site is included in the Chapter 33 subdirectory.

The Role of the `Global.asax` File

At this point, an ASP.NET application might seem little more than a set of `.aspx` files and their respective web controls. While you could build a web application by simply linking a set of related web pages, you will most likely need a way to interact with the web application as a whole. To this end, an ASP.NET application may choose to include an optional `Global.asax` file via the `WebSite` ► `Add New Item` menu option, shown in Figure 33-2. (Notice you are selecting the `Global Application Class` icon.)

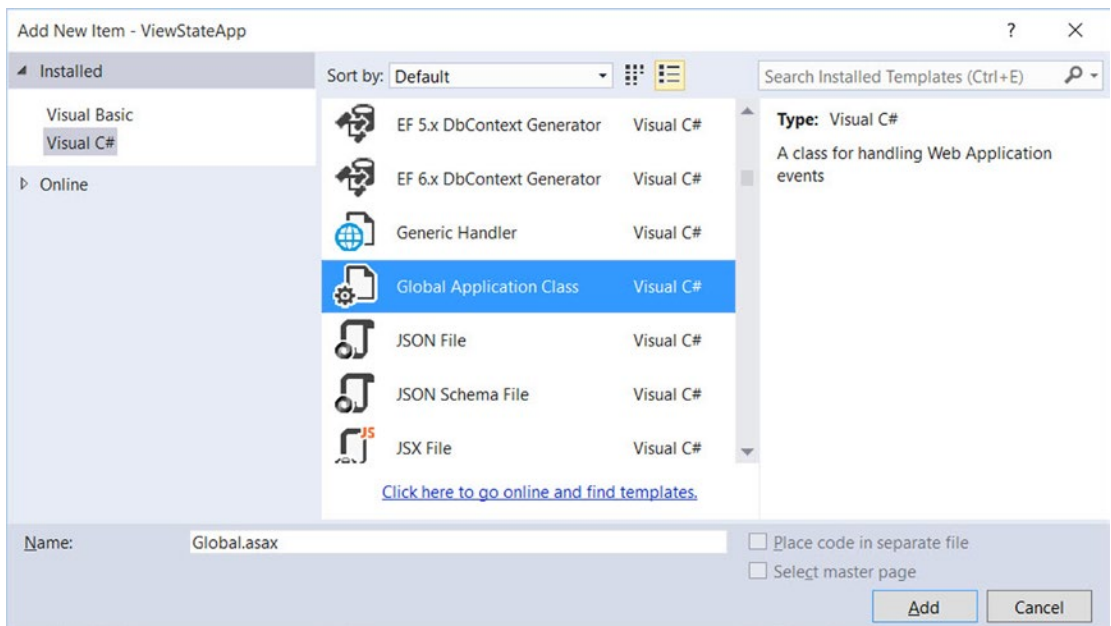

Figure 33-2. The `Global.asax` file

Simply put, `Global.asax` is just about as close to a traditional double-clickable *.exe as you can get in the world of ASP.NET, meaning this type represents the runtime behavior of the web site itself. When you insert a `Global.asax` file into a web project, you'll see that it's little more than a `<script>` block containing a set of event handlers, like this:

```
<%@ Application Language="C#" %>

<script runat="server">
    void Application_Start(object sender, EventArgs e)
    {
        // Code that runs on application startup.
    }

    void Application_End(object sender, EventArgs e)
    {
        // Code that runs on application shutdown.
    }

    void Application_Error(object sender, EventArgs e)
    {
        // Code that runs when an unhandled error occurs.
    }
    void Session_Start(object sender, EventArgs e)
    {
        // Code that runs when a new session is started.
    }
    void Session_End(object sender, EventArgs e)
    {
        // Code that runs when a session ends.
        // Note: The Session_End event is raised only when the sessionstate mode
        // is set to InProc in the web.config file. If session mode is set to
        // StateServer or SQLServer, the event is not raised.
    }
</script>
```

Looks can be deceiving, however. At runtime, the code within this `<script>` block is assembled into a class type deriving from `System.Web.HttpApplication`. Therefore, within any of the provided event handlers, you can access parent class members via the `this` or `base` keywords.

As mentioned, the members defined inside `Global.asax` are event handlers that allow you to interact with application-level (and session-level) events. Table 33-1 documents the role of each member.

Table 33-1. Core Types of the System.Web Namespace

| Event Handler | Meaning in Life |
|---------------------|---|
| Application_Start() | This event handler is called the very first time the web application is launched. Thus, this event will fire exactly once over the lifetime of a web application. It is an ideal place to define the application-level data used throughout your web application. |
| Application_End() | This event handler is called when the application is shutting down. This will occur when the last user times out or if you manually shut down the application via IIS. |
| Session_Start() | This event handler is fired when a new user reaches your application. Here you can establish any user-specific data points you want to preserve across postbacks. |
| Session_End() | This event handler is fired when a user's session has terminated (typically through a predefined timeout). |
| Application_Error() | This is a global error handler that will be called when an unhandled exception is thrown by the web application. |

The Global Last-Chance Exception Event Handler

First, let's talk about the role of the `Application_Error()` event handler. Recall that a specific page may handle the `Error` event to process any unhandled exception that occurred within the scope of the page itself. In a similar light, the `Application_Error()` event handler is the final place to handle an exception that was not handled by a given page. As with the page-level `Error` event, you are able to access the specific `System.Exception` using the inherited `Server` property, like so:

```
void Application_Error(object sender, EventArgs e)
{
    // Obtain the unhandled error.
    Exception ex = Server.GetLastError();

    // Process error here...

    // Clear error when finished.
    Server.ClearError();
}
```

Given that the `Application_Error()` event handler is the last-chance exception handler for your web application, it is quite common to implement this method in such a way that the user is transferred to a predefined error page on the server. Other common duties could include sending an e-mail to the web administrator or writing to an external error log.

The `HttpApplication` Base Class

As mentioned, the `Global.asax` script is dynamically generated as a class deriving from the `System.Web.HttpApplication` base class, which supplies some of the same sort of functionality as the `System.Web.UI.Page` type (without a visible user interface). Table 33-2 documents the key members of interest.

Table 33-2. *Key Members Defined by the `System.Web.HttpApplication` Type*

| Property | Meaning in Life |
|--------------------------|---|
| <code>Application</code> | This property allows you to interact with application-level data, using the exposed <code>HttpApplicationState</code> type. |
| <code>Request</code> | This property allows you to interact with the incoming HTTP request, using the underlying <code>HttpRequest</code> object. |
| <code>Response</code> | This property allows you to interact with the incoming HTTP response, using the underlying <code>HttpResponse</code> object. |
| <code>Server</code> | This property gets the intrinsic server object for the current request, using the underlying <code>HttpServerUtility</code> object. |
| <code>Session</code> | This property allows you to interact with session-level data, using the underlying <code>HttpSessionState</code> object. |

Again, given that the `Global.asax` file does not explicitly document that `HttpApplication` is the underlying base class, it is important to remember that all of the rules of the “is-a” relationship do indeed apply.

Understanding the Application/Session Distinction

Under ASP.NET, application state is maintained by an instance of the `HttpApplicationState` type. This class enables you to share global information across all users (and all pages) using your ASP.NET application. Not only can application data be shared by all users on your site, but also if the value of an application-level data point changes, the new value is seen by all users on their next postback.

On the other hand, session state is used to remember information for a specific user (again, such as items in a shopping cart). Physically, a user’s session state is represented by the `HttpSessionState` class type. When a new user reaches an ASP.NET web application, the runtime will automatically assign that user a new session ID, which by default will expire after 20 minutes of inactivity. Thus, if 20,000 users are logged on to your site, you have 20,000 distinct `HttpSessionState` objects, each of which is automatically assigned a unique session ID. The relationship between a web application and web sessions is shown in Figure 33-3.

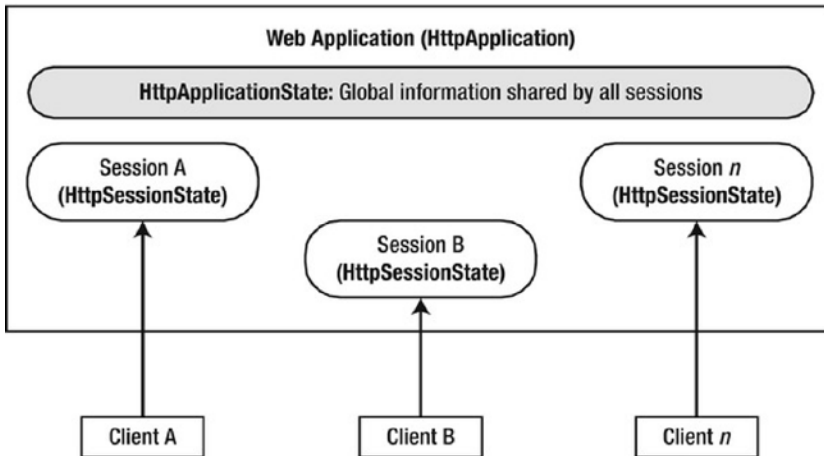

Figure 33-3. The application/session state distinction

Maintaining Application-Level State Data

The `HttpApplicationState` type enables developers to share global information across multiple users in an ASP.NET application. Table 33-3 describes some core members of this type.

Table 33-3. Members of the `HttpApplicationState` Type

| Members | Meaning in Life |
|--|---|
| <code>Add()</code> | This method allows you to add a new name/value pair to the <code>HttpApplicationState</code> object. Note that this method is typically <i>not</i> used in favor of the indexer of the <code>HttpApplicationState</code> class. |
| <code>AllKeys</code> | This property returns an array of <code>string</code> objects that represent all the names in the <code>HttpApplicationState</code> type. |
| <code>Clear()</code> | This method deletes all items in the <code>HttpApplicationState</code> object. This is functionally equivalent to the <code>RemoveAll()</code> method. |
| <code>Count</code> | This property gets the number of item objects in the <code>HttpApplicationState</code> type. |
| <code>Lock()</code> , <code>Unlock()</code> | These two methods are used when you want to alter a set of application variables in a thread-safe manner. |
| <code>RemoveAll()</code> , <code>Remove()</code> , <code>RemoveAt()</code> | These methods remove a specific item (by string name) within the <code>HttpApplicationState</code> object. <code>RemoveAt()</code> removes the item via a numerical indexer. |

To illustrate working with application state, create a new Empty Web Site project named AppState (and insert a new Web Form). Next, insert a new Global.asax file. When you create data members that can be shared among all users, you need to establish a set of name/value pairs. In most cases, the most natural place to do so is within the Application_Start() event handler in Global.asax.cs, like so:

```
void Application_Start(Object sender, EventArgs e)
{
    // Set up some application variables.
    Application["SalesPersonOfTheMonth"] = "Chucky";
    Application["CurrentCarOnSale"] = "Colt";
    Application["MostPopularColorOnLot"] = "Black";
}
```

During the lifetime of your web application (which is to say, until the web application is manually shut down or until the final user times out), any user on any page may access these values as necessary. Assume you have a page that will display the current discount car within a Label via a button Click event handler, like so:

```
protected void btnShowCarOnSale_Click(object sender, EventArgs arg)
{
    lblCurrCarOnSale.Text = string.Format("Sale on {0}'s today!",
        (string)Application["CurrentCarOnSale"]);
}
```

As with the ViewState property, notice how you should cast the value returned from the HttpSessionState object into the correct underlying type because the Application property operates on general System.Object types.

Now, given that the Application property can hold any type, it should stand to reason that you can place custom types (or any .NET object) within your site's application state. Assume you'd rather maintain the three current application variables within a strongly typed class named CarLotInfo, as follows:

```
public class CarLotInfo
{
    public CarLotInfo(string salesPerson, string currentCar, string mostPopular)
    {
        SalesPersonOfTheMonth = salesPerson;
        CurrentCarOnSale = currentCar;
        MostPopularColorOnLot = mostPopular;
    }
    public string SalesPersonOfTheMonth { get; set; }
    public string CurrentCarOnSale { get; set; }
    public string MostPopularColorOnLot { get; set; }
}
```

With this helper class in place, you could modify the Application_Start() event handler as follows:

```
void Application_Start(Object sender, EventArgs e)
{
    // Place a custom object in the application data sector.
    Application["CarSiteInfo"] =
        new CarLotInfo("Chucky", "Colt", "Black");
}
```

You could then access the information using the public field data within a server-side Click event handler for a Button control named btnShowAppVariables, as follows:

```
protected void btnShowAppVariables_Click(object sender, EventArgs e)
{
    CarLotInfo appVars =
        ((CarLotInfo)Application["CarSiteInfo"]);
    string appState = $"<li>Car on sale: { appVars.CurrentCarOnSale }</li>"
    appState += $"<li>Most popular color: { appVars.MostPopularColorOnLot }</li>";
    appState += $"<li>Big shot SalesPerson: { appVars.SalesPersonOfTheMonth }</li>"
    lblAppVariables.Text = appState;
}
```

Given that the current car-on-sale data is now exposed from a custom class type, your btnShowCarOnSale Click event handler would also need to be updated, like so:

```
protected void btnShowCarOnSale_Click(object sender, EventArgs e)
{
    lblCurrCarOnSale.Text =
        $"Sale on {(CarLotInfo)Application["CarSiteInfo"]}.CurrentCarOnSale }'s today!";
}
```

Modifying Application Data

You may programmatically update or delete any or all application-wide data items using members of the HttpSessionState type during the execution of your web application. For example, to delete a specific item, simply call the Remove() method. If you want to destroy all application-level data, call RemoveAll().

```
private void CleanAppData()
{
    // Remove a single item via string name.
    Application.Remove("SomeItemIDontNeed");

    // Destroy all application data!
    Application.RemoveAll();
}
```

If you want to change the value of an existing application-level data item, you need only make a new assignment to the data item in question. Assume your page now has a Button that allows your user to change the current hotshot salesperson by reading in a value from a TextBox named txtNewSP. The Click event handler here is as you'd expect:

```
protected void btnSetNewSP_Click(object sender, EventArgs e)
{
    // Set the new Salesperson.
    ((CarLotInfo)Application["CarSiteInfo"]).SalesPersonOfTheMonth
        = txtNewSP.Text;
}
```

If you run the web application, you'll find that the application-level data item has been updated. Furthermore, given that application variables are accessible by any user on any page in the web application, if you launched three or four instances of your web browser, you'd find that if one instance changes the current salesperson, each of the other browsers displays the new value on postback. Figure 33-4 shows some possible output.

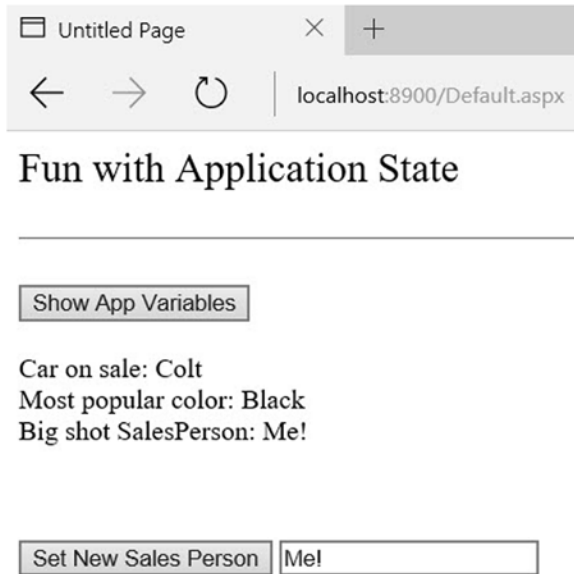

Figure 33-4. *Displaying application data*

Understand that if you have a situation where a set of application-level variables must be updated as a unit, you risk the possibility of data corruption since it is technically possible that an application-level data point may be changed while another user is attempting to access it! You could take the long road and manually lock down the logic using threading primitives of the `System.Threading` namespace, but the `HttpApplicationState` type has two methods, `Lock()` and `Unlock()`, that automatically ensure thread safety:

// Safely access related application data.

```
Application.Lock();
Application["SalesPersonOfTheMonth"] = "Maxine";
Application["CurrentBonusedEmployee"] = Application["SalesPersonOfTheMonth"];
Application.Unlock();
```

Handling Web Application Shutdown

The `HttpApplicationState` type is designed to maintain the values of the items it contains until one of two situations occurs: the last user on your site times out (or manually logs out) or someone manually shuts down the web site via IIS. In either case, the `Application_End()` method of the `HttpApplication`-derived type will automatically be called. Within this event handler, you are able to perform whatever sort of cleanup is necessary.

```
void Application_End(Object sender, EventArgs e)
{
    // Write current application variables
    // to a database or whatever else you need to do.
}
```

■ **Source Code** The AppState web site is included in the Chapter 33 subdirectory.

Working with the Application Cache

ASP.NET provides a second and more flexible way to handle application-wide data. As you recall, the values within the `HttpApplicationState` object remain in memory as long as your web application is alive and kicking. Sometimes, however, you might want to maintain a piece of application data only for a specific period of time. For example, you might want to obtain an ADO.NET `DataSet` that is valid for only five minutes. After that time, you might want to obtain a fresh `DataSet` to account for possible database updates. While it's technically possible to build this infrastructure using `HttpApplicationState` and some sort of handcrafted monitor, the ASP.NET application cache greatly simplifies your task.

As its name suggests, the ASP.NET `System.Web.Caching.Cache` object (which is accessible via the `Context.Cache` property) allows you to define objects that are accessible by all users from all pages for a fixed amount of time. In its simplest form, interacting with the cache looks identical to interacting with the `HttpApplicationState` type.

```
// Add an item to the cache.
// This item will *not* expire.
Context.Cache["SomeStringItem"] = "This is the string item";
// Get item from the cache.
string s = (string)Context.Cache["SomeStringItem"];
```

■ **Note** If you want to access the cache from within `Global.asax`, you need to use the `Context` property. However, if you are within the scope of a `System.Web.UI.Page`-derived type, you can access the `Cache` object directly via the page's `Cache` property.

The `System.Web.Caching.Cache` class defines only a small number of members beyond the type's indexer. You can use the `Add()` method to insert a new item into the cache that is not currently defined (if the specified item is already present, `Add()` effectively does nothing). The `Insert()` method will also place a member into the cache. If the item is currently defined, however, `Insert()` will replace the current item with the new object. Since this is generally the behavior you'll desire, I'll focus on the `Insert()` method exclusively.

Fun with Data Caching

Let's see an example. To begin, create a new Empty Web Site named `CacheState` and insert a Web Form and a `Global.asax` file. Like any application-level data item maintained by the `HttpApplicationState` type, the cache may hold any `System.Object`-derived type and is often populated within the `Application_Start()`

event handler. For this example, the goal is to automatically update the contents of a DataSet every 15 seconds. The DataSet in question will contain the current set of records from the Inventory table of the AutoLot database created during our discussion of ADO.NET.

Given these design notes, set a reference to AutoLotDAL.dll (see Chapter 31; it's also included in the code download for this chapter), add Entity Framework (EF) to your site (using the Manage NuGet Packages context menu on the project name), and add the correct ConnectionString to your web.config like this (your connection string might differ based on your installation of SQL Server Express):

```
<connectionStrings>
<add name="AutoLotConnection" connectionString="data source=(local)\SQLEXPRESS2014;initial
catalog=AutoLot;integrated security=True;MultipleActiveResultSets=True;App=EntityFramework"
providerName="System.Data.SqlClient" />
</connectionStrings>
```

Once you have configured your site for EF and added the reference to AutoLotDAL.dll, update your Global.asax like so (code analysis to follow):

```
<%@ Application Language="C#" %>
<%@ Import Namespace = "AutoLotDAL.Repos" %>

<script runat="server">
    // Define a static-level Cache member variable.
    static Cache _theCache;

    void Application_Start(Object sender, EventArgs e)
    {
        // First assign the static "theCache" variable.
        _theCache = Context.Cache;

        // When the application starts up,
        // read the current records in the
        // Inventory table of the AutoLot DB.
        var theCars = new InventoryRepo().GetAll();

        // Now store DataTable in the cache.
        _theCache.Insert("CarList",
            theCars,
            null,
            DateTime.Now.AddSeconds(15),
            Cache.NoSlidingExpiration,
            CacheItemPriority.Default,
            UpdateCarInventory);
    }

    // The target for the CacheItemRemovedCallback delegate.
    static void UpdateCarInventory(string key, object item,
        CacheItemRemovedReason reason)
    {
        var theCars = new InventoryRepo().GetAll();
        // Now store in the cache.
        _theCache.Insert("CarList",
            theCars,
```

```

        null,
        DateTime.Now.AddSeconds(15),
        Cache.NoSlidingExpiration,
        CacheItemPriority.Default,
        UpdateCarInventory);
    }
</script>

```

First, notice you've defined a static `Cache` member variable. The reason is that you've defined two static members that need to access the `Cache` object. Recall that static methods do not have access to inherited members, so you can't use the `Context` property!

Inside the `Application_Start()` event handler, you get the list of `Inventory` items and insert it into the application cache. As you would guess, the `Context.Cache.Insert()` method has been overloaded a number of times. Here, you supply a value for each possible parameter. Consider the following commented call to `Insert()`:

```

_theCache.Insert("CarList", // Name used to identify item in the cache.
    theCars,                // Object to put in the cache.
    null,                   // Any dependencies for this object?
    DateTime.Now.AddSeconds(15), // Absolute timeout value.
    Cache.NoSlidingExpiration, // Don't use sliding expiration (see below).
    CacheItemPriority.Default, // Priority level of cache item.
    // Delegate for CacheItemRemove event.
    UpdateCarInventory);

```

The first two parameters simply make up the name/value pair of the item. The third parameter allows you to define a `CacheDependency` object (which is `null` in this case because the `IList<Inventory>` does not depend on anything).

The `DateTime.Now.AddSeconds(15)` parameter specifies an absolute expiration time. It means the cache item will definitely be evicted from the cache after 15 seconds. Absolute expiration is useful for data items that need to be constantly refreshed (such as a stock ticker).

The `Cache.NoSlidingExpiration` parameter specifies that the cache item doesn't use sliding expiration. Sliding expiration is a way of keeping an item in the cache for at least a certain amount of time. For example, if you set a sliding expiration of 60 seconds for a cache item, it will live in the cache for at least 60 seconds. If any web page accesses the cache item within that time, the clock is reset and the cache item has a fresh 60 seconds to live. If no web page accesses the cache item in 60 seconds, the item is removed from the cache. Sliding expiration is useful for data that might be expensive (time-wise) to generate, but which might not be used very frequently by web pages.

Note that you can't specify both an absolute expiration and a sliding expiration for a given cache item. You set either an absolute expiration (and use `Cache.NoSlidingExpiration`) or a sliding expiration (and use `Cache.NoAbsoluteExpiration`).

Finally, as you can see from the signature of the `UpdateCarInventory()` method, the `CacheItemRemovedCallback` delegate can only call methods that match the following signature:

```

void UpdateCarInventory(string key, object item, CacheItemRemovedReason reason)
{
}

```

So, when the application starts up, the `DataTable` is populated and cached. Every 15 seconds, the `DataTable` is purged, updated, and reinserted into the cache. To see the effects of doing this, you need to create a page that allows for some degree of user interaction.

Modifying the *.aspx File

Figure 33-5 shows a UI that allows the user to enter the necessary data to insert a new record into the database (via three different TextBox controls). The Click event for the single Button control will be coded (in just a bit) to handle the database manipulation. Finally, minus a number of descriptive Label controls, the GridView on the bottom of the page will be used to display the set of current records in the Inventory table.



Figure 33-5. The cache application GUI

In the page's Load event handler, configure your GridView to display the current contents of the cached data the first time the user posts to the page (be sure to import the `AutoLotDAL.Models` and `AutoLotDAL.Repos` namespaces within your code file).

```
protected void Page_Load(object sender, EventArgs e)
{
    if (!IsPostBack)
    {
        carsGridView.DataSource = (IList<Inventory>)Cache["AppDataTable"];
        carsGridView.DataBind();
    }
}
```

In the Click event handler of the Add This Car button, insert the new record into the AutoLot database using the `InventoryRepo` type. After the record has been inserted, call a helper function named `RefreshGrid()`, which will update the UI.

```
protected void btnAddCar_Click(object sender, EventArgs e)
{
    // Update the Inventory table
    // and call RefreshGrid().
    new InventoryRepo().Add(new Inventory()
    {
        Color = txtCarColor.Text,
        Make = txtCarMake.Text,
        PetName = txtCarPetName.Text
    });
    RefreshGrid();
}

private void RefreshGrid()
{
    carsGridView.DataSource = new InventoryRepo().GetAll();
    carsGridView.DataBind();
}
```

Now, to test the use of the cache, begin by running the current program (Ctrl+F5) and copy the URL appearing in the browser to your clipboard. Next, launch a second instance of your browser (using the Start button) and paste the URL into this instance. At this point, you should have two instances of your web browser, both viewing `Default.aspx` and showing identical data.

In one instance of the browser, add a new automobile entry. Obviously, this results in an updated GridView viewable from the browser that initiated the postback.

In the second browser instance, click the Refresh button (F5). You should not see the new item, since the `Page_Load` event handler is reading directly from the cache. (If you did see the value, the 15 seconds had already expired. Either type faster or increase the amount of time the data will remain in the cache.) Wait a few seconds and click the Refresh button from the second browser instance one more time. Now you should see the new item, given that the data in the cache has expired and the `CacheItemRemovedCallback` delegate target method has automatically updated the cached data.

As you can see, the major benefit of the `Cache` type is that you can ensure that when an item is removed, you have a chance to respond. In this example, you certainly could avoid using the `Cache` and simply have the `Page_Load()` event handler always read directly from the `AutoLot` database (but this would potentially be much slower than the caching approach). Nevertheless, the point should be clear: the cache allows you to automatically refresh data using the cache mechanism.

■ **Source Code** The `CacheState` web site is included in the Chapter 33 subdirectory.

Maintaining Session Data

So much for our examination of application-level and cached data. Next, let's check out the role of per-user data. As mentioned, a *session* is little more than a given user's ongoing interaction with a web application, which is represented via a unique `HttpSessionState` object. To maintain stateful information for a particular user, you can use the `Session` property in your web page class or in `Global.asax`. The classic example of the need to maintain per-user data is an online shopping cart. Again, if 10 people all log on to an online store, each individual will have a unique set of items that she (might) intend to purchase, and that data needs to be maintained.

When a new user joins to your web application, the .NET runtime automatically assigns the user a unique session ID, which is used to identify that user. Each session ID identifies a custom instance of the `HttpSessionState` type to hold user-specific data. Inserting or retrieving session data is syntactically identical to manipulating application data. For example,

```
// Add/retrieve session data for current user.
Session["DesiredCarColor"] = "Green";
string color = (string) Session["DesiredCarColor"];
```

In `Global.asax`, you can intercept the beginning and end of a session via the `Session_Start()` and `Session_End()` event handlers. Within `Session_Start()`, you can freely create any per-user data items, while `Session_End()` allows you to perform any work you might need to do when the user's session has terminated.

```
<%@ Application Language="C#" %>
...
void Session_Start(Object sender, EventArgs e)
{
    // New session! Prep if required.
}

void Session_End(Object sender, EventArgs e)
{
    // User logged off/timed out. Tear down if needed.
}
```

Like application state, session state may hold any `System.Object`-derived type, including your custom classes. For example, assume you have a new Empty Web Site project (named `SessionState`) that defines a class named `UserShoppingCart`, as follows:

```
public class UserShoppingCart
{
    public string DesiredCar {get; set;}
    public string DesiredCarColor {get; set;}
    public float DownPayment {get; set;}
    public bool IsLeasing {get; set;}
    public DateTime DateOfPickUp {get; set;}

    public override string ToString() =>
        $"Car: {DesiredCar}<br>Color: {DesiredCarColor}<br>$ Down: {DownPayment}" +
        $"<br>Lease: {IsLeasing}<br>Pick-up Date: {DateOfPickUp.ToShortDateString()}";
}
```

Now, insert a `Global.asax` file. Within the `Session_Start()` event handler, you can now assign each user a new instance of the `UserShoppingCart` class, like so:

```
void Session_Start(Object sender, EventArgs e)
{
    Session["UserShoppingCartInfo"] = new UserShoppingCart();
}
```

As the user traverses your web pages, you are able to pluck out the `UserShoppingCart` instance and fill the fields with user-specific data. For example, assume you have a simple `*.aspx` page that defines a set of input controls that correspond to each field of the `UserShoppingCart` type, a `Button` for setting the values, and two `Labels` that will be used to display the user's session ID and session information (see [Figure 33-6](#)).

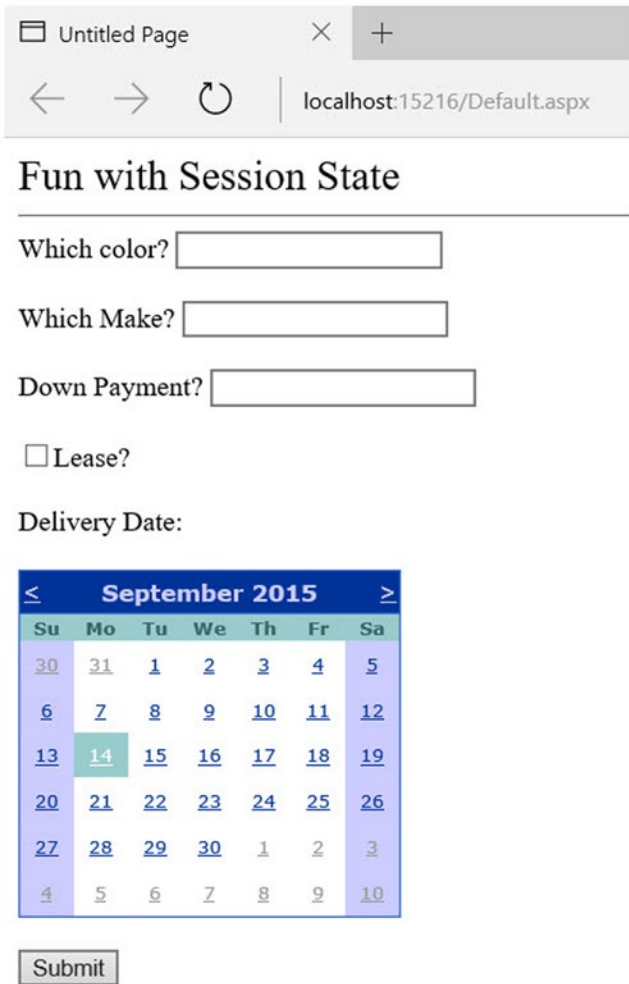

Figure 33-6. The session application GUI

The server-side Click event handler for the Button control is straightforward (scrape out values from TextBoxes and display the shopping cart data on a Label control).

```
protected void btnSubmit_Click(object sender, EventArgs e)
{
    // Set current user prefs.
    var cart = (UserShoppingCart)Session["UserShoppingCartInfo"];
    cart.DateOfPickUp = myCalendar.SelectedDate;
    cart.DesiredCar = txtCarMake.Text;
    cart.DesiredCarColor = txtCarColor.Text;
    cart.DownPayment = float.Parse(txtDownPayment.Text);
    cart.IsLeasing = chkIsLeasing.Checked;
    lblUserInfo.Text = cart.ToString();
    Session["UserShoppingCartInfo"] = cart;
}
```

Within `Session_End()`, you might elect to persist the fields of the `UserShoppingCart` to a database or whatnot (however, as you will see at the conclusion of this chapter, the ASP.NET Profile API will do so automatically). As well, you might want to implement `Session_Error()` to trap any faulty input (or perhaps make use of various validation controls on the `Default.aspx` page to account for such user errors).

In any case, if you were to launch two or three instances of your browser of choice all posting to the same URL (via a copy/paste operation as you did for the data cache example), you would find that each user is able to build a custom shopping cart that maps to his unique instance of `HttpSessionState`.

Additional Members of `HttpSessionState`

The `HttpSessionState` class defines a number of other members of interest beyond the type indexer. First, the `SessionID` property will return the current user's unique ID. If you would like to view the automatically assigned session ID for this example, handle the `Load` event of your page as follows:

```
protected void Page_Load(object sender, EventArgs e)
{
    lblUserID.Text = $"Here is your ID: { Session.SessionID }";
}
```

The `Remove()` and `RemoveAll()` methods may be used to clear items out of the user's instance of `HttpSessionState`, like so:

```
Session.Remove("SomeItemWeDontNeedAnymore");
```

The `HttpSessionState` type also defines a set of members that control the expiration policy of the current session. Again, by default each user has 20 minutes of inactivity before the `HttpSessionState` object is destroyed. Thus, if a user enters your web application (and therefore obtains a unique session ID), but then does not return to the site within 20 minutes, the runtime assumes the user is no longer interested and destroys all session data for that user. You are free to change this default 20-minute expiration value on a user-by-user basis using the `Timeout` property. The most common place to do so is within the scope of your `Session_Start()` method, like so:

```
void Session_Start(Object sender, EventArgs e)
{
    // Each user has 5 minutes of inactivity.
    Session.Timeout = 5;
    Session["UserShoppingCartInfo"]
        = new UserShoppingCart();
}
```

■ **Note** If you do not need to tweak each user's `Timeout` value, you can alter the 20-minute default for all users via the `timeout` attribute of the `<sessionState>` element within the `web.config` file (examined at the end of this chapter).

The benefit of the `Timeout` property is that you have the ability to assign specific timeout values separately for each user. For example, imagine you have created a web application that allows users to pay cash for a given membership level. You could specify that Gold members should time out within one hour, while Wood members should get only 30 seconds. This possibility begs the question, how can you remember user-specific information (such as the current membership level) if users close the browser and come back at a later time? One possible answer is through the use of the `HttpCookie` type. (And speaking of cookies . . .)

■ **Source Code** The `SessionState` web site is included in the Chapter 32 subdirectory.

Understanding Cookies

The next state management technique you'll examine is the persisting of data within a *cookie*, which is often realized as a text file (or set of files) on the user's machine. When a user joins a given site, the browser checks to see whether the user's machine has a cookie file for the URL in question and, if so, appends this data to the HTTP request.

The receiving server-side web page can then read the cookie data to create a GUI based on the current user preferences. I'm sure you've noticed that when you visit certain of your favorite web sites, they somehow "just know" the sort of content you would like to see. The reason (in part) may have to do with a cookie stored on your computer that contains information relevant to a given web site.

■ **Note** The exact location of your cookie files depends on which browser and operating system you happen to be using.

The contents of a given cookie file will obviously vary among web sites, but keep in mind that they are ultimately text files. Thus, cookies are a horrible choice for maintaining sensitive information about the current user (such as a credit card number, password, and the like). Even if you take the time to encrypt the data, a crafty hacker could decrypt the value and use it for evil purposes. In any case, cookies do play a role in the development of web applications, so let's check out how ASP.NET handles this particular state management technique.

Creating Cookies

First of all, understand that ASP.NET cookies can be configured to be either persistent or temporary. A *persistent* cookie is typically regarded as the classic definition of cookie data, in that the set of name/value pairs is physically saved to the user's hard drive. A *temporary* cookie (also termed a *session cookie*) contains the same data as a persistent cookie, but the name/value pairs are never saved to the user's hard drive; rather, they exist *only* while the browser is open. When the user shuts down the browser, all data contained in the session cookie is destroyed.

The `System.Web.HttpCookie` type is the class that represents the server side of the cookie data (persistent or temporary). When you want to create a new cookie in your web page code, you access the `Response.Cookies` property. Once the new `HttpCookie` is inserted into the internal collection, the name/value pairs flow back to the browser within the HTTP header.

To check out cookie behavior firsthand, create a new Empty Web Site (named `CookieStateApp`) and create the UI of the first Web Form (which you will need to insert) displayed in Figure 33-7.



Figure 33-7. The UI of *CookieStateApp*

Within the first button's Click event handler, build a new `HttpCookie` and insert it into the `Cookie` collection exposed from the `HttpRequest.Cookies` property. Be very aware that the data will not persist itself to the user's hard drive unless you explicitly set an expiration date using the `HttpCookie.Expires` property. Thus, the following implementation will create a temporary cookie that is destroyed when the user shuts down the browser:

```
protected void btnCookie_Click(object sender, EventArgs e)
{
    // Make a temp cookie.
    HttpCookie theCookie = new HttpCookie(txtCookieName.Text,txtCookieValue.Text);
    Response.Cookies.Add(theCookie);
}
```

However, the following generates a persistent cookie that will expire three months from today:

```
protected void btnCookie_Click(object sender, EventArgs e)
{
    HttpCookie theCookie = new HttpCookie(txtCookieName.Text,txtCookieValue.Text);
    theCookie.Expires = DateTime.Now.AddMonths(3);
    Response.Cookies.Add(theCookie);
}
```

Reading Incoming Cookie Data

Recall that the browser is the entity in charge of accessing persisted cookies when navigating to a previously visited page. If a browser decides to send a cookie to the server, you can access the incoming data in your *.aspx page via the `HttpRequest.Cookies` property. To illustrate, implement the `Click` event handler for the second button like so:

```
protected void btnShowCookie_Click(object sender, EventArgs e)
{
    string cookieData = "";
    foreach (string s in Request.Cookies)
    {
        cookieData +=
            $"<li><b>Name</b>: {s}, <b>Value</b>: { Request.Cookies[s]?.Value }</li>";
    }
    lblCookieData.Text = cookieData;
}
```

If you now run the application and click your new button, you will find that the cookie data has indeed been sent by your browser and accessed successfully in your *.aspx code at the server, as shown in Figure 33-8.

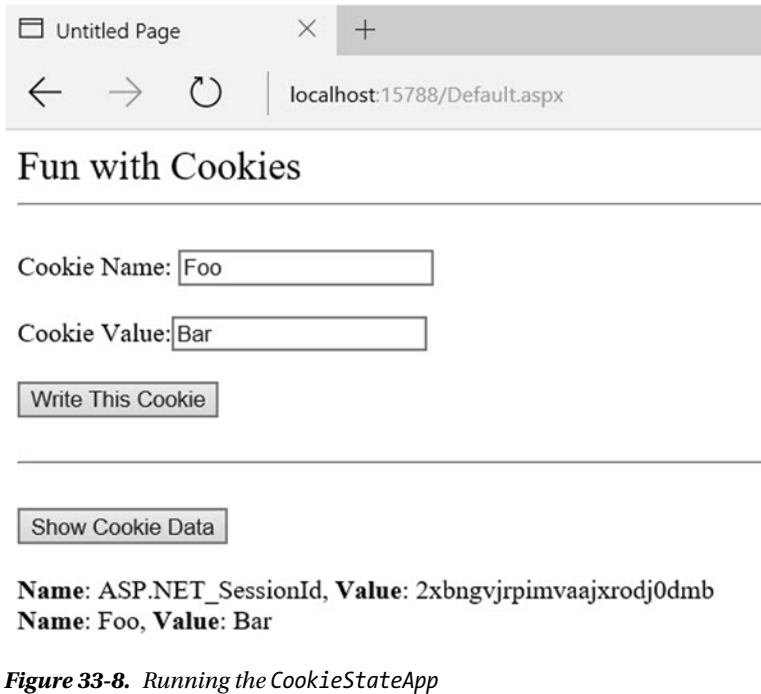

Figure 33-8. Running the `CookieStateApp`

■ **Source Code** The CookieStateApp web site is included in the Chapter 33 subdirectory.

The Role of the <sessionState> Element

At this point, you have examined numerous ways to remember information about your users. As you have seen, view state and application, cache, session, and cookie data are manipulated programmatically in more or less the same way (via a class indexer). As you have also seen, `Global.asax` has methods that allow you to intercept and respond to events that occur during your web application's lifetime.

By default, ASP.NET will store session state in-process. The plus side is that access to the information is as fast as possible. However, the downside is that if this `AppDomain` crashes (for whatever reason), all of the user's state data is destroyed. Furthermore, when you store state data as an in-process *.dll, you cannot interact with a networked web farm. This default mode of storage works just fine if your web application is hosted by a single web server. As you might guess, however, this model is not ideal for a farm of web servers, given that session state is "trapped" within a given `AppDomain`.

Storing Session Data in the ASP.NET Session State Server

Under ASP.NET, you can instruct the runtime to host the session state *.dll in a surrogate process named the ASP.NET session state server (`aspnet_state.exe`). When you do so, you are able to offload the *.dll from `aspnet_wp.exe` into a unique *.exe, which can be located on any machine within the web farm. Even if you intend to run the `aspnet_state.exe` process on the same machine as the web server, you gain the benefit of partitioning the state data in a unique process (as it is more durable).

To make use of the session state server, the first step is to start the `aspnet_state.exe` Windows service on the target machine by typing the following in a Developer Command Prompt window (note that you will need admin privileges to do so):

```
net start aspnet_state
```

Alternatively, you can start `aspnet_state.exe` using the Services applet accessed from the Administrative Tools folder of the Control Panel, as shown in Figure 33-9.

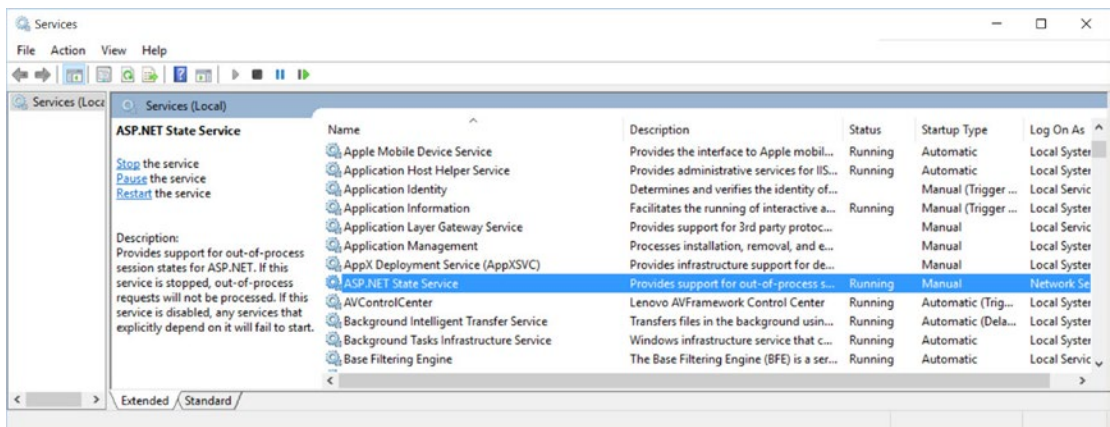

Figure 33-9. Starting `aspnet_state.exe` using the Services applet

The key benefit of this approach is that you can use the Properties window to configure `aspnet_state.exe` to start automatically when the machine boots up. In any case, once the session state server is running, add the following `<sessionState>` element of your `web.config` file:

```
<system.web>
  <sessionState
    mode="StateServer"
    stateConnectionString="tcpip=127.0.0.1:42626"
    sqlConnectionString="data source=127.0.0.1;Trusted_Connection=yes"
    cookieless="false"
    timeout="20"
  />
  ...
</system.web>
```

That's it! At this point, the CLR will host session-centric data within `aspnet_state.exe`. In this way, if the AppDomain hosting the web application crashes, the session data is preserved. Moreover, note that the `<sessionState>` element can also support a `stateConnectionString` attribute. The default TCP/IP address value (127.0.0.1) points to the local machine. If you would rather have the .NET runtime use the `aspnet_state.exe` service located on another networked machine (again, think web farms), you are free to update this value.

Storing Session Data in a Dedicated Database

Finally, if you require the highest degree of isolation and durability for your web application, you may choose to have the runtime store all your session state data within Microsoft SQL Server. The following appropriate update to the `web.config` file is simple:

```
<sessionState
  mode="SQLServer"
  stateConnectionString="tcpip=127.0.0.1:42626"
  sqlConnectionString="data source=127.0.0.1;Trusted_Connection=yes"
  cookieless="false"
  timeout="20"
/>
```

However, before you attempt to run the associated web application, you need to ensure that the target machine (specified by the `sqlConnectionString` attribute) has been properly configured. When you install the .NET Framework 4.6 SDK (or Visual Studio proper), you will be provided with two files named `InstallSqlState.sql` and `UninstallSqlState.sql`, located by default under `C:\Windows\Microsoft.NET\Framework\<version>`. On the target machine, you must run the `InstallSqlState.sql` file using a tool such as the Microsoft SQL Server Management Studio (which ships with Microsoft SQL Server).

After you have run `InstallSqlState.sql`, you will find a new SQL Server database has been created (ASPState), which contains a number of stored procedures called by the ASP.NET runtime, as well as a set of tables used to store the session data itself. (Also, the `tempdb` database has been updated with a set of tables for swapping purposes.) As you'd guess, configuring your web application to store session data within SQL Server is the slowest of all possible options. The benefit is that user data is as durable as possible (even if the web server is rebooted).

■ **Note** If you use the ASP.NET session state server or SQL Server to store your session data, you must make sure that any custom types placed in the `HttpSessionState` object have been marked with the `[Serializable]` attribute.

Introducing the ASP.NET Profile API

So far you have examined numerous techniques that allow you to remember user-level and application-level bits of data. However, many web sites require the ability to persist user information across sessions. For example, perhaps you need to give users the ability to build an account on your site. Maybe you need to persist instances of a `ShoppingCart` class across sessions (for an online shopping site). Or perhaps you need to persist basic user preferences (themes, etc.).

While you could build a custom database (with several stored procedures) to hold such information, you would then need to build a custom code library to interact with these database objects. This is not necessarily a complex task, but the bottom line is that *you* are the individual in charge of building this sort of infrastructure.

To help simplify matters, ASP.NET ships with an out-of-the-box user profile management API and database system for this very purpose. In addition to providing the necessary infrastructure, the Profile API allows you to define the data to be persisted directly within your `web.config` file (for purposes of simplification); however, you are also able to persist any `[Serializable]` type. Before we get too far ahead of ourselves, let's check out where the Profile API will be storing the specified data.

The ASPNETDB.mdf Database

Every ASP.NET web site built with Visual Studio can support an `App_Data` subdirectory. By default, the Profile API (as well as other services, such as the ASP.NET role membership API, which is not examined in this text) is configured to make use of a local SQL Server database named `ASPNETDB.mdf`, located within the `App_Data` folder. This default behavior is due to settings within the `machine.config` file for the current .NET installation on your machine. In fact, when your code base makes use of any ASP.NET service requiring the `App_Data` folder, the `ASPNETDB.mdf` data file will be automatically created on the fly if a copy does not currently exist.

If you'd rather have the ASP.NET runtime communicate with an `ASPNETDB.mdf` file located on another networked machine, or you'd prefer to install this database on an instance of SQL Server 7.0 (or higher), you will need to manually build `ASPNETDB.mdf` using the `aspnet_regsql.exe` command-line utility. Like any good command-line tool, `aspnet_regsql.exe` provides numerous options; however, if you run the tool with no arguments (from a Developer Command Prompt window), like

```
aspnet_regsql
```

you will launch a GUI-based wizard that will walk you through the process of creating and installing `ASPNETDB.mdf` on your machine (and version of SQL Server) of choice.

Now, assuming your site is not using a local copy of the database under the App_Data folder, the final step is to update your web.config file to point to the unique location of your ASPNETDB.mdf. Assume you have installed ASPNETDB.mdf on a machine named ProductionServer. The following (partial) machine.config file would instruct the Profile API where to find the necessary database items in their default location (you could add a custom web.config to change these defaults):

```
<configuration>
  <connectionStrings>
    <add name="LocalSqlServer"
        connectionString="Data Source=ProductionServer;Integrated
        Security=SSPI;Initial Catalog=aspnetdb;"
        providerName="System.Data.SqlClient"/>
  </connectionStrings>
  <system.web>
    <profile>
      <providers>
        <clear/>
        <add name="AspNetSqlProfileProvider"
            connectionStringName="LocalSqlServer"
            applicationName="/"
            type="System.Web.Profile.SqlProfileProvider, System.Web,
            Version=4.0.0.0,
            Culture=neutral, PublicKeyToken=b03f5f7f11d50a3a" />
      </providers>
    </profile>
  </system.web>
</configuration>
```

Like most *.config files, this looks much worse than it is. Basically you are defining a <connectionString> element with the necessary data, followed by a named instance of the SqlProfileProvider (this is the default provider used regardless of physical location of the ASPNETDB.mdf).

■ **Note** For simplicity, I will assume that you'll use the autogenerated ASPNETDB.mdf database located in your web application's App_Data subdirectory.

Defining a User Profile Within web.config

As mentioned, a user profile is defined within a web.config file. The really nifty aspect of this approach is that you can interact with this profile in a strongly typed manner using the inherited Profile property in your code files. To illustrate this, create a new Empty Web Site named FunWithProfiles, add a new *.aspx file, and open your web.config file for editing.

The goal is to make a profile that models the home address of the users who are in session, as well as the total number of times they have posted to this site. Not surprisingly, profile data is defined within a `<profile>` element using a set of name/data type pairs. Consider the following profile, which is created within the scope of the `<system.web>` element:

```
<profile>
  <properties>
    <add name="StreetAddress" type="System.String" />
    <add name="City" type="System.String" />
    <add name="State" type="System.String" />
    <add name="TotalPost" type="System.Int32" />
  </properties>
</profile>
```

Here, you have specified a name and CLR data type for each item in the profile (of course, you could add additional items for ZIP code, name, and so forth, but I am sure you get the idea). Strictly speaking, the `type` attribute is optional; however, the default is a `System.String`. There are many other attributes that can be specified in a profile entry to further qualify how this information should be persisted in `ASPNETDB.mdf`. Table 33-4 illustrates some of the core attributes.

Table 33-4. *Select Attributes of Profile Data*

| Attribute | Example Values | Meaning in Life |
|-----------------------------|--------------------------------|---|
| <code>allowAnonymous</code> | True False | Restricts or allows anonymous access to this value. If it is set to <code>false</code> , anonymous users won't have access to this profile value. |
| <code>defaultValue</code> | String | The value to return if the property has not been explicitly set. |
| <code>Name</code> | String | A unique identifier for this property. |
| <code>Provider</code> | String | The provider used to manage this value. It overrides the <code>defaultProvider</code> setting in <code>web.config</code> or <code>machine.config</code> . |
| <code>readOnly</code> | True False | Restricts or allows write access. The default is <code>false</code> (i.e., it's not read-only). |
| <code>serializeAs</code> | String XML Binary | The format of a value when persisting in the data store. |
| <code>type</code> | Primitive User- defined type | A .NET primitive type or class. Class names must be fully qualified (e.g., <code>MyApp.UserData.ColorPrefs</code>). |

You will see some of these attributes in action as you modify the current profile. For now, let's see how to access this data programmatically from within our pages.

Accessing Profile Data Programmatically

Recall that the whole purpose of the ASP.NET Profile API is to automate the process of writing data to (and reading data from) a dedicated database. To test this out for yourself, update the UI of your `Default.aspx` file with a set of `TextBox`s (and descriptive `Label`s) to gather the street address, city, and state of the user. As well, add a `Button` (named `btnSubmit`) and a final `Label` (named `lblUserData`) to display the persisted data, as shown in Figure 33-10.

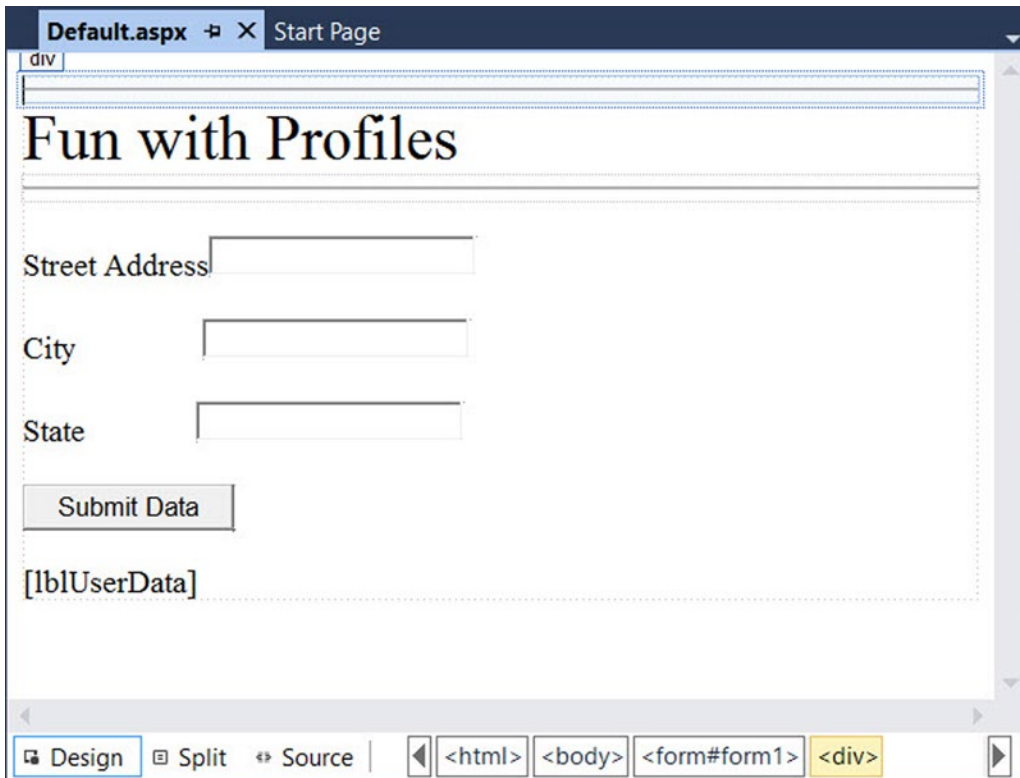

Figure 33-10. The UI of the `FunWithProfiles Default.aspx` page

Now, within the `Click` event handler of the button, use the inherited `Profile` property to persist each point of profile data based on what the user has entered in the related `TextBox`. After you have persisted each piece of data within `ASPNETDB.mdf`, read each piece of data out of the database and format it into a `string` that is displayed on the `lblUserData` `Label` type. Finally, handle the page's `Load` event, and display the same information on the `Label` type. In this way, when users come to the page, they can see their current settings. Here is the complete code file:

```
public partial class _Default : System.Web.UI.Page
{
    protected void Page_Load(object sender, EventArgs e)
    {
        GetUserAddress();
    }
}
```

```

protected void btnSubmit_Click(object sender, EventArgs e)
{
    // Database writes happening here!
    Profile.StreetAddress = txtStreetAddress.Text;
    Profile.City = txtCity.Text;
    Profile.State = txtState.Text;

    // Get settings from database.
    GetUserAddress();
}

private void GetUserAddress()
{
    // Database reads happening here!
    lblUserData.Text =
        $"You live here: {Profile.StreetAddress }, {Profile.City}, {Profile.State}";
}
}

```

Now if you run this page, you will notice a lengthy delay the first time `Default.aspx` is requested. The reason is that the `ASPNETDB.mdf` file is being created on the fly and placed within your `App_Data` folder (you can verify this for yourself by refreshing the Solution Explorer window and looking in the `App_Data` folder).

You will also find that the first time you come to this page, the `lblUserData` Label does not display any profile data because you have not yet entered your data into the correct table of `ASPNETDB.mdf`. After you enter values in the `TextBox` controls and post back to the server, this Label will be formatted with the persisted data.

Now for the really interesting aspect of this technology: if you shut down your browser and rerun your web site, you will find that your previously entered profile data has indeed been persisted because the Label displays the correct information. This begs the obvious question, how were you remembered?

For this example, the Profile API used your Windows network identity, which was obtained via your current machine credentials. However, when you are building public web sites (where the users are not part of a given domain), rest assured that the Profile API integrates with the Forms-based authentication model of ASP.NET and also supports the notion of “anonymous profiles,” which allow you to persist profile data for users who do not currently have an active identity on your site.

■ **Note** This edition of the text does not address ASP.NET security topics (such as Forms-based authentication or anonymous profiles). Consult the .NET Framework 4.6 SDK documentation for details.

Grouping Profile Data and Persisting Custom Objects

Finally, let's look at how profile data may be defined within a `web.config` file. The current profile simply defined four pieces of data that were exposed directly from the profile type. When you build more complex profiles, it can be helpful to group related pieces of data under a unique name. Consider the following update:

```
<profile>
  <properties>
    <group name = "Address">
      <add name="StreetAddress" type="String" />
      <add name="City" type="String" />
      <add name="State" type="String" />
    </group>
    <add name="TotalPost" type="Integer" />
  </properties>
</profile>
```

This time, you have defined a custom group named `Address` to expose the street address, city, and state of your user. To access this data in your pages would now require you to update your code base by specifying `Profile.Address` to get each subitem. For example, here is the updated `GetUserAddress()` method (the Click event handler for the Button would need to be updated in a similar manner):

```
private void GetUserAddress()
{
  // Database reads happening here!
  lblUserData.Text =
    $"You live here: {Profile.Address.StreetAddress}, {Profile.Address.City}, " +
    $"{Profile.Address.State}";
}
```

Before you run this example, you need to delete `ASPNETDB.mdf` from your `App_Data` folder to ensure the database schema is refreshed. After you have done so, you should be able to run your web site example without error.

■ **Note** A profile can contain as many groups as you feel are necessary. Simply define multiple `<group>` elements within your `<properties>` scope.

Finally, it is worth pointing out that a profile may also persist (and obtain) custom objects to and from `ASPNETDB.mdf`. To illustrate, assume you want to build a custom class (or structure) that will represent the user's address data. The only requirement expected by the Profile API is that the type be marked with the `[Serializable]` attribute, like so:

```
[Serializable]
public class UserAddress
{
  public string Street = string.Empty;
  public string City = string.Empty;
  public string State = string.Empty;
}
```

With this class in place, your profile definition can now be updated as follows (notice I removed the custom group, although this is not mandatory):

```
<profile>
  <properties>
    <add name="AddressInfo" type="UserAddress" serializeAs ="Binary"/>
    <add name="TotalPost" type="Integer" />
  </properties>
</profile>
```

Note that when you are adding [Serializable] types to a profile, the type attribute is the fully qualified name of the type being persisted. As you will see from the Visual Studio IntelliSense, your core choices are binary, XML, or string data. Now that you are capturing street address information as a custom class type, you (once again) need to update your code base as follows:

```
private void GetUserAddress()
{
  // Database reads happening here!
  lblUserData.Text =
    $"You live here: {Profile.AddressInfo.Street}, {Profile.AddressInfo.City}, " +
    $"{Profile.AddressInfo.State}";
}
```

To be sure, there is much more to the Profile API than I've had space to cover here. For example, the Profile property actually encapsulates a type named ProfileCommon. Using this type, you can programmatically obtain all information for a given user, delete (or add) profiles to ASPNETDB.mdf, update aspects of a profile, and so forth.

Moreover, the Profile API has numerous points of extensibility that can allow you to optimize how the profile manager accesses the tables of the ASPNETDB.mdf database. As you would expect, there are many ways to decrease the number of "hits" this database takes. Interested readers are encouraged to consult the .NET Framework 4.6 SDK documentation for further details.

■ **Source Code** The FunWithProfiles web site is included in the Chapter 33 subdirectory.

Summary

In this chapter, you rounded out your knowledge of ASP.NET by examining how to leverage the `HttpApplication` type. As you have seen, this type provides a number of default event handlers that allow you to intercept various application- and session-level events. The bulk of this chapter was spent exploring a number of state management techniques. Recall that view state is used to automatically repopulate the values of HTML widgets between postbacks to a specific page. Next, you checked out the distinction of application- and session-level data, cookie management, and the ASP.NET application cache.

Finally, this chapter exposed you to the ASP.NET Profile API. As you have seen, this technology provides an out-of-the-box solution for the issue of persisting user data across sessions. Using your web site's `web.config` file, you can define any number of profile items (including groups of items and [Serializable] types) that will automatically be persisted into ASPNETDB.mdf.

CHAPTER 34



ASP.NET MVC and Web API

The last three chapters covered ASP.NET Web Forms as well as web-related concepts such as HTTP and HTML. This chapter introduces two newcomers to the ASP.NET ecosystem: ASP.NET MVC and Web API. MVC grew out of the user community (specifically the ALT.NET movement) asking for a framework that more closely adhered to the tenants of HTTP, was more testable, and adhered to separation of concerns. While Web Forms still controls the market share of the .NET web development ecosystem, MVC is rapidly growing its adoption rate.

This chapter begins with a brief explanation of the MVC pattern and then dives right into creating an MVC project. There is a lot of scaffolding that comes with the default project template, and the next sections cover the parts that are created for you. After getting a solid understanding of MVC, you will build the inventory pages for CarLotMVC, an MVC-based subset of the web site you built in the last three chapters.

The next section introduces you to Web API, a service framework built largely on the chassis of MVC, and shares many of the concepts, including routing, controllers, and actions. ASP.NET Web API allows you to leverage your MVC knowledge to build RESTful services without the configuration and plumbing that WCF (Chapter 25) requires. You will create a RESTful service called CarLotWebAPI that exposes all of the create, read, update, delete (CRUD) functionality on the inventory records. Finally, you finish the chapter by updating CarLotMVC to use CarLotWebAPI as the data source, instead of using Entity Framework and AutoLotDAL.

Introducing the MVC Pattern

The Model-View-Controller (MVC) pattern has been around since the 1970s (created as a pattern used in Smalltalk) but has exploded in popularity fairly recently. Many languages have MVC frameworks, including Java (most notably in the Spring Framework), Ruby (Ruby on Rails), .NET (with the introduction of ASP.NET MVC in 2007), and many JavaScript client frameworks such as Angular and EmberJS.

If the description of the pattern that follows reminds you of the Model-View-ViewModel pattern (covered in Chapter 30), you are correct. MVVM leverages many components of MVC (along with the Presentation Model pattern). Enough history. Let's get into the pattern!

The Model

Just like in MVVM, the model is the data of your application. The data is typically represented by plain old CLR objects (POCOs), as you built in the AutoLotDAL library (Chapter 23) and used in the MVVM examples (Chapter 30). The model classes can (and often do) have validation built in and, depending on the client-side JavaScript framework used (such as knockout.js), can be configured as observables.

The View

The view is the UI of the application and renders the output to the user. The view should be as lightweight as is practical.

The Controller

The controller is the brains of the operation. Controllers have two responsibilities; the first is taking commands/requests from the user (referred to as *actions*) and correctly marshaling them appropriately (such as to a repository), and the second is to send any changes to the view. Controllers (as well as models and views) should be lightweight and leverage other components to maintain separation of concerns. This all sounds simple, doesn't it? Before you dive into building an MVC application, there is that age-old question...

Why MVC?

By the time ASP.NET MVC was released in 2007, ASP.NET Web Forms had been in production for six years. Thousands of sites built on Web Forms were in production, with more and more coming online every day. So, why would Microsoft make a new framework from scratch? Before we answer that, a short look backward in time is appropriate.

When Microsoft first released ASP.NET Web Forms, web development wasn't as prolific as it is today. The stateless paradigm was a difficult one to grasp, especially for smart client developers (such as those making desktop apps with Visual Basic 6, MFC, and PowerBuilder). To bridge the knowledge gap and make it easier for developers to build web sites, Web Forms enabled many of the desktop concepts, such as state (through viewstate) and prebuilt controls.

The plan worked. Web Forms was generally well received, and many developers made the jump to web developers. The number of web sites based on Web Forms continued to grow, and the story of .NET evolved. A thriving third-party ecosystem suppling Web Forms controls (and many other .NET controls) grew up in lockstep with Web Forms and .NET. Everything was coming up roses!

At the same time, developers were learning more about (and becoming comfortable with) the statelessness of programming for the Web, the HTTP protocol, HTML, and JavaScript. These developers needed the bridging technologies less and less and wanted more and more control of the rendered views.

With each new version of Web Forms, additional features and capabilities were added into the framework, each adding to the weight of the applications. The increasing complexity of web sites being developed meant items such as viewstate were growing seemingly out of control. Even worse, some early decisions made in the creation of Web Forms (such as *where* viewstate was placed in the rendered page) were causing issues such as performance degradation to rear their ugly heads. This was causing some high-profile "defections" from .NET to other languages, like Ruby (using Ruby on Rails).

But Microsoft couldn't (and wisely wouldn't) remove those bridging technologies and other code from the ASP.NET core without risking millions of lines of code. Something had to be done, and retooling Web Forms wasn't an option (although as you learned in the previous chapters, significant work was put into ASP.NET Web Forms 4.5 to resolve a whole host of issues). Microsoft had some hard decisions to make: how to keep the existing web developers (and the control ecosystem that grew up with Web Forms) happy and productive, while providing a platform for those developers who wanted to be closer to the metal of the Web.

Enter ASP.NET MVC

Thus, for all of those reasons, a new framework was born. ASP.NET MVC was created to be an alternative to ASP.NET Web Forms. There are some noticeable differences between ASP.NET Web Forms and ASP.NET MVC, including the following:

- Removing:
 - Code-behind files for views
 - Server-side control support
 - Viewstate
- Adding:
 - Model binding
 - Routing
 - The Razor View Engine (starting with MVC 3)

The result is a lightweight framework built on the speed of rendering and designed for testability and separation of concerns, but also requiring a deeper knowledge of HTML and JavaScript and the way HTTP actually works. Since the versions up to and including MVC5 are still built on the same core .NET libraries as Web Forms and Web API, combining Web Forms, MVC, and/or Web API becomes a viable deployment pattern. Each has strengths and weaknesses, and you should pick the right tool for the right job.

Convention over Configuration

One of the tenants of ASP.NET MVC is convention over configuration. This means that there are specific conventions (such as naming conventions and directory structure) for MVC projects that enable a lot of “magic” to be done for you by Visual Studio and .NET. This reduces the amount of manual or templated configuration necessary, but it also means you need to know the conventions. As you progress through this chapter, you will see several of the conventions in action.

Building Your First ASP.NET MVC Application

Enough theory. It’s time for code. Visual Studio ships with a rather complete project template for building ASP.NET MVC apps, and you will take full advantage of that when you build CarLotMVC.

The New Project Wizard

Start by launching Visual Studio, selecting File ► New ► Project. In the left sidebar, select Web under Visual C#, select ASP.NET Web Application, and change Name to CarLotMVC, as shown in Figure 34-1.

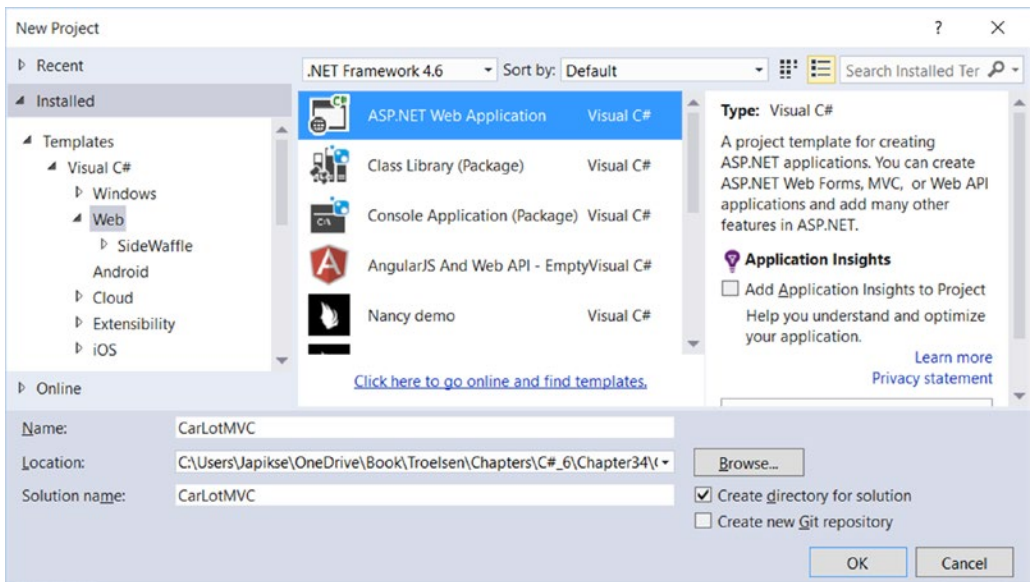

Figure 34-1. Creating a new ASP.NET web application

If you’ve been following along with the previous chapters on ASP.NET, you will notice that this is the same way you started building an ASP.NET Web Forms application. All ASP.NET application types (Web Forms, MVC, Web API) start with a single selection in the New Project Wizard, instead of having to choose a specific framework. Known as One ASP.NET, this change was introduced in .NET 4.5.

On the next screen, select MVC under ASP.NET 4.6 Templates. Notice that the MVC check box is selected under “Add folders and core references for:” and the others are not. If you wanted to create a hybrid application that supported MVC *and* Web Forms, you could select the Web Forms check box as well. For this example, just select MVC app, as shown in Figure 34-2. Also notice the “Add unit tests” check box. If you select this option, another project will be created for you that provides a basic framework for unit testing your ASP.NET application. Don’t click OK yet, as you’ll examine the authentication mechanisms for your project.

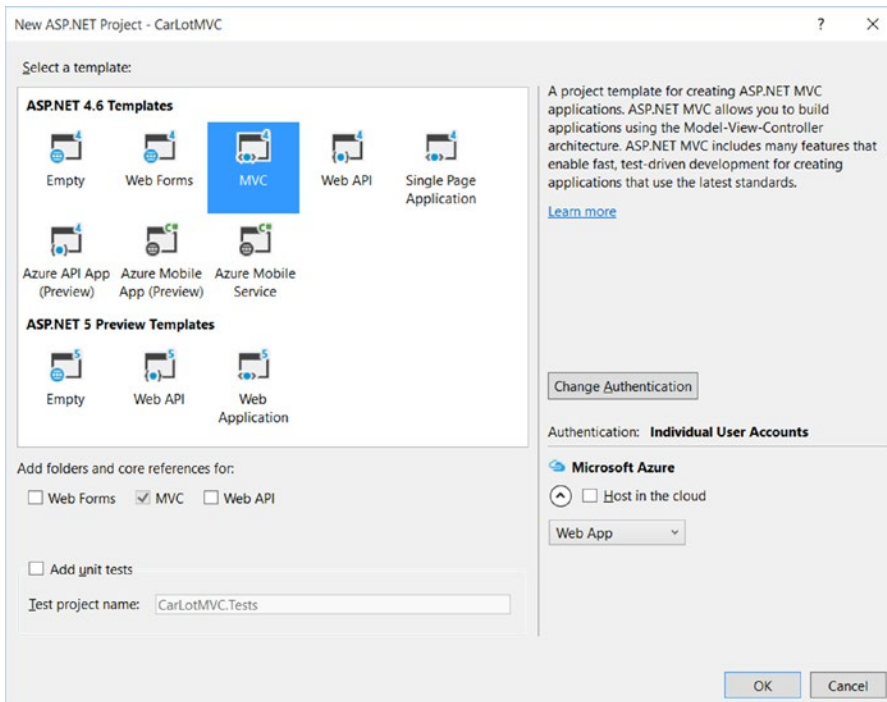

Figure 34-2. Selecting MVC

Click the Change Authentication button, and you will see the dialog shown in Figure 34-3. Leave the default set to Individual User Accounts (the default), click OK, and click OK in the Select a Template dialog.

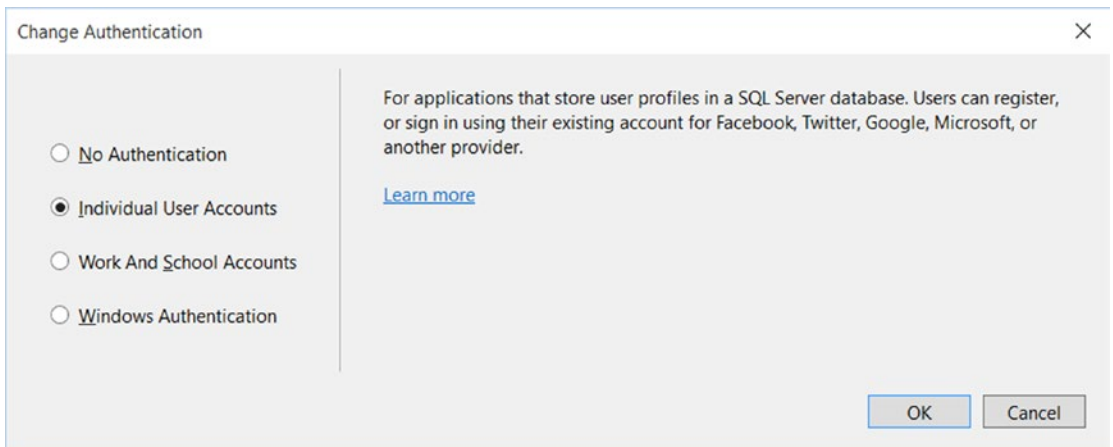

Figure 34-3. Authentication options for the project

Table 34-1 discusses the four authentication options available to MVC applications.

Table 34-1. *Authentication Choices*

| Option | Meaning in Life |
|--------------------------|--|
| No Authentication | No mechanism for logging in, entity classes for membership, or a membership database. |
| Individual User Accounts | Uses ASP.NET Identity (formerly known as ASP.NET Membership) for user authentication. |
| Work and School Accounts | For applications that authenticate with Active Directory, Azure Active Directory, or Office 365. |
| Windows Authentication | Uses Windows Authentication. Intended for intranet web sites. |

■ **Note** I don't cover authentication in this book because of space limitations. For more information on authentication in MVC, please see Adam Freeman's book *Pro ASP.NET MVC5*.

Once that's completed, you will see a *lot* of generated files and folders, as in Figure 34-4. You'll be examining these in the next section.

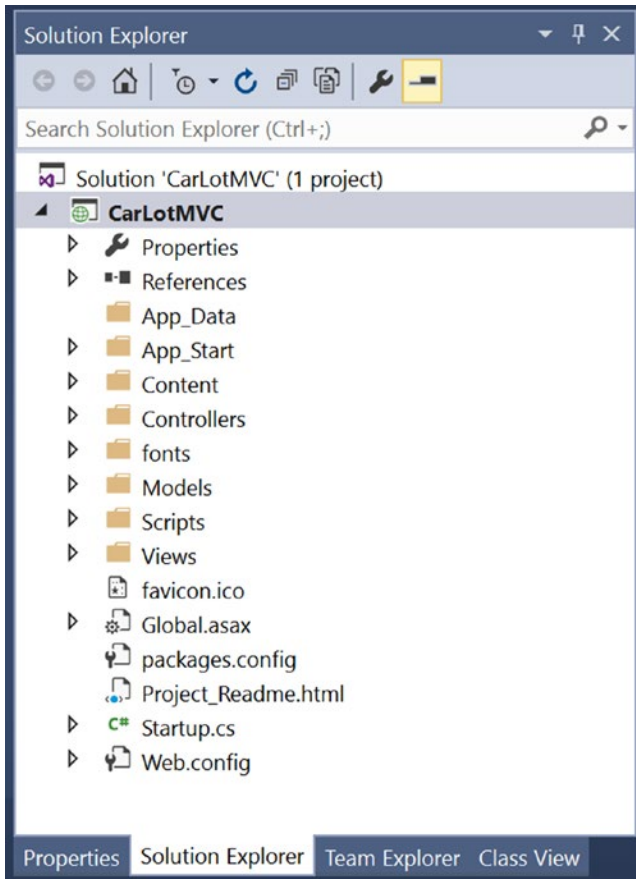

Figure 34-4. The generated files and folders for an MVC app

The Components of a Base MVC Project

Some of the folders and files should look familiar to you because they are named the same as the files and folders available to ASP.NET Web Forms projects.

Project Root Files

Most of the files in MVC projects have specific locations where they should be placed. However, there are a few files that are in the root of the project, and not all of them get deployed with the web site. Table 34-2 lists the files in the root of the MVC site and whether or not they are deployed.

Table 34-2. *Files in the Project Root*

| File | Meaning in Life | Deployed? |
|--------------------------------|---|----------------|
| favicon.ico | The icon that is displayed by browsers in the address bar next to the page name. Not having this can cause performance issues, as browser will continually look for this. | Yes |
| Global.asax/ Global.asax.cs | The entry point into the application (like ASP.NET Web Forms). | Yes |
| packages.config | Configuration information for NuGet packages used in the project. | Yes |
| Project_Readme.html | Visual Studio-specific file that provides useful links and other information about ASP.MVC. | No |
| Startup.cs | Startup class for OWIN (ASP.NET Identity). | Yes (Compiled) |
| Web.config | Project configuration file. | Yes |

Global.asax.cs

The `Global.asax.cs` file is where you hook into the ASP.NET pipeline. The events are the same events available to ASP.NET Web Forms. The default project template uses only the `Application_Start` event handler, but there are many more events that can be hooked into if you need them. Table 34-3 lists the most commonly used events.

Table 34-3. *Commonly Used Global.asax.cs Events*

| Event | Meaning in Life |
|---------------------------------------|---|
| <code>Application_Start</code> | Raised on first request for the application |
| <code>Application_End</code> | Raised when the application ends |
| <code>Application_Error</code> | Raised when an unhandled error occurs |
| <code>Session_Start</code> | Raised when a first request for a new session |
| <code>Session_End</code> | Raised when a session ends (or times out) |
| <code>Application_BeginRequest</code> | Raised when a request is made to the server |
| <code>Application_EndRequest</code> | Raised as the last event in the HTTP pipeline chain of execution when ASP.NET responds to a request |

The Models Folder

This is exactly what it sounds like; it's the place to put model classes. In larger applications, you should use a data access library to hold your data access models. The `Models` folder is most commonly used for view-specific models, such as the model classes generated by Visual Studio for ASP.NET Identity.

The Controllers Folder

Again, just as the name implies, the `Controllers` folder is where the controllers in your application live. I will cover controllers in great detail later in this chapter.

The Views Folder

The Views folder is where the MVC views are stored (as the name suggests), but unlike the Models and Controllers folders, there is a convention for the directory structure contained in the Views folder.

In the root of the Views folder there is a `Web.config` file and a file named `_ViewStart.cshtml`. The `Web.config` file is specific for the views in this folder hierarchy, defines the base page type (e.g., `System.Web.Mvc.WebViewPage`), and, in Razor-based projects, adds all the references and using statements for Razor. The `_ViewStart.cshtml` file specifies the default layout view to use if one is not specifically assigned for a view. This will be discussed in greater detail with layouts. The layout view is analogous to the master page in Web Forms and will be covered in more detail later in this chapter.

■ **Note** Why the leading underscore for `_ViewStart.html` (and `_Layout.cshtml`)? The Razor View Engine was originally created for WebMatrix, which would allow any file that did *not* start with an underscore to be rendered, so core files (such as layout and configuration) all have names that began with an underscore. You will also see this naming convention used for partial views. However, this is not a convention that MVC cares about since MVC doesn't have the same issue as WebMatrix, but the underscore legacy lives on anyway.

Each controller gets its own folder under the Views folder. This folder structure is part of the MVC convention; controllers look for their views in a folder of the same name as the controller (minus the word *Controller*). For example, the `Views/Home` folder holds all the views for the `HomeController` controller class.

The Shared Folder

A special folder under Views is named `Shared`. This folder is accessible to all views.

The ASP.NET Folders

There are also folders reserved for ASP.NET. An example of this is the `App_Data` ASP.NET folder that is included in the default MVC template. This folder is a special folder designed to store any file-based data needed by the site. There are also folders for storing code, resources, and themes. The ASP.NET folders can be added by right-clicking the project, selecting `Add ► Add New ASP.NET Web Folder`, and selecting one from the dialog shown in Figure 34-5. The ASP.NET folders are not viewable from the web site, even if folder navigation is enabled.

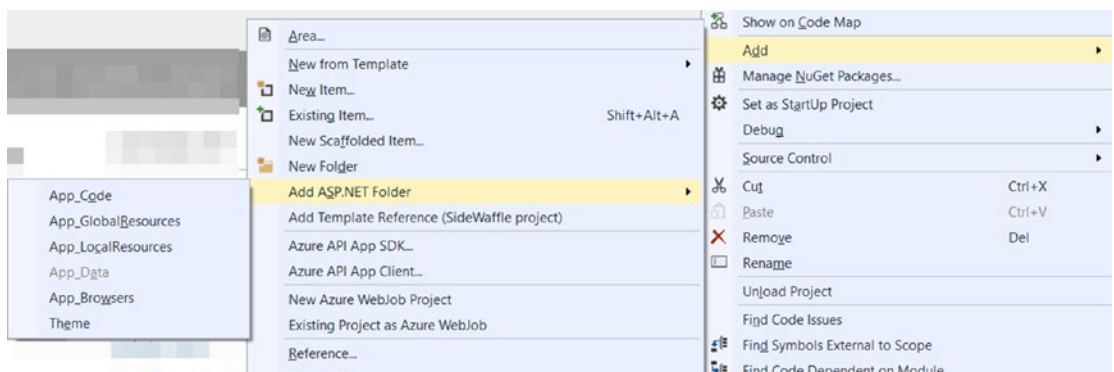

Figure 34-5. Adding new ASP.NET folders

Table 34-4 lists the available ASP.NET web folders.

Table 34-4. *ASP.NET Web Folders*

| Folder | Meaning in Life |
|---------------------|--|
| App_Code | Code files contained in this folder are dynamically compiled. |
| App_GlobalResources | Holds resource files available to the entire application. Typically used for localization. |
| App_LocalResources | Contains resources available to a specific page. Typically used for localization. |
| App_Data | Contains file-based data used by the application. |
| App_Browsers | Place to hold browser capability files. |
| App_Themes | Holds themes for the site. |

The App_Start Folder

Early versions of MVC contained all the site configuration code (such as routing and security) in the `Global.asax.cs` class. As the amount of configuration grew, the developers on the MVC team wisely split the code into separate classes to better follow single responsibility. Out of this refactoring, the `App_Start` folder and its contained classes were born (details in Table 34-5). Any code in the `App_Start` folder gets automatically compiled into the site.

Table 34-5. *Files in App_Start*

| File | Meaning in Life |
|--------------------------------|---|
| <code>BundleConfig.cs</code> | Creates the files bundles for JavaScript and CSS files. Additional bundles can (and should) be created in this class. |
| <code>FilterConfig.cs</code> | Registers action filters (such as authentication or authorization) at a global scope. |
| <code>IdentityConfig.cs</code> | Contains support classes for ASP.NET Identity. |
| <code>RouteConfig.cs</code> | Class where the routing table is configured. |
| <code>Startup.Auth.cs</code> | Entry point for configuration of ASP.NET Identity. |

BundleConfig

This class sets up the bundles for CSS and JavaScript files. By default, when using `ScriptBundle`, all included files are bundled and minified (see the next section for an explanation of bundling and minification) for production and not bundled or minified for debug mode. This can be controlled through `Web.config` or in the class itself. To turn off bundling and minification, enter the following into the `system.web` section of your top-level `Web.config` (if it doesn't already exist):

```
<system.web>
  <compilation debug="true" targetFramework="4.6" />
</system.web>
```

Or add `BundleTable.EnableOptimizations = false` in the `RegisterBundles` method in `BundleConfig.cs`, as follows:

```
public static void RegisterBundles(BundleCollection bundles)
{
    bundles.Add(new ScriptBundle("~/bundles/jquery").Include("~/Scripts/jquery-{version}.js"));
    // Code removed for clarity.
    BundleTable.EnableOptimizations = false;
}
```

Bundling

Bundling is the process of combining multiple files into one. This is done for a couple of reasons; the main reason is to speed up your site. Browsers have a limit of how many files they will download concurrently from a single server. If your site contains a lot of small files (which is usually a good idea in support of separation of concerns and single responsibility), this can slow down your users' experience. Bundling and using content delivery networks (CDNs) can help resolve this. Of course, you need to temper your actions with wisdom since having one gigantic file probably isn't going to be any better than a million little ones.

Minification

Like bundling, minification is designed to speed up load time for web pages. For CSS and JavaScript files to be readable, they are typically written with meaningful variable and function names, comments, and other formatting (at least they should be). The problem is that every bit getting sent over the wire counts, especially when dealing with mobile clients.

Minification is a process of replacing long names with short (sometimes just one-character) names, removing extra spaces, as well as other formatting. Most modern frameworks ship with two versions of their CSS and JavaScript files. Bootstrap is no different, shipping with `bootstrap.css` for use while developing your application and `bootstrap.min.css` for production.

FilterConfig

Filters are custom classes that provide a mechanism to intercept actions and requests. They can be applied at the action, controller, or global level. There are four types of filters in MVC, as listed in Table 34-6.

Table 34-6. *Filters in ASP.NET MVC*

| Filter Type | Meaning in Life |
|---------------|--|
| Authorization | These implement <code>IAuthorizationFilter</code> and run before any other filter. Two examples are <code>Authorize</code> and <code>AllowAnonymous</code> . For example, the <code>AccountController</code> class is annotated with the <code>[Authorize]</code> attribute to require an authenticated user through Identity, and the <code>Login</code> action is marked with the <code>[AllowAnonymous]</code> attribute to allow any user. |
| Action | Implement <code>IActionFilter</code> and allow for interception of action execution with <code>OnActionExecuting</code> and <code>OnActionExecuted</code> . |
| Result | Implement <code>IResultFilter</code> and intercept the result of an action with <code>OnResultExecuting</code> and <code>OnResultExecuted</code> . |
| Exception | Implement <code>IExceptionFilter</code> and execute if an unhandled exception is thrown during the execution of the ASP.NET pipeline. By default, the <code>HandleError</code> filter is configured at the global level. This filter displays the error view page <code>Error.cshtml</code> located in the <code>Shared/Error</code> folder. |

Identity

`Identity.config.cs` and `Startup.Auth.cs` are both used to support ASP.NET Identity. Identity is too big of a topic to be covered as part of this chapter. In fact, one could write a book on all the details around security and identity. As mentioned early, ASP.NET Identity is based on OWIN, separating Identity from its dependency on IIS. While this separation doesn't come into play for MVC using the .NET 4.6 framework, it can be significant in ASP.NET Web API if you are self-hosting your service.

RouteConfig

Early versions of ASP.NET Web Forms defined the URLs of the site based on the physical folder structure of the project. This could be changed with `HttpModules` and `HttpHandlers`, but that was far from ideal. MVC from the start included routing, which enables you to shape the URLs to better suit your users. This will be covered in greater detail later in this chapter.

The Content Folder

The Content folder is designed to hold your site's CSS files. This is also commonly used to hold images and other non-programmatic content. Unlike many of the folders listed here, there isn't a dependency on this folder name; it's just a convention of convenience.

ASP.NET MVC ships with Bootstrap, one of the most popular HTML, CSS, and JavaScript frameworks in use today. Two of the default CSS files (`bootstrap.css` and `bootstrap.min.css`) are part of Bootstrap, and `site.css` is where you would put your site-specific CSS.

Bootstrap

Bootstrap is an open source HTML, CSS, and JavaScript framework for developing responsive, Mobile First web sites. Microsoft started including Bootstrap with MVC4 and continues to ship it with MVC5, and the default project template for MVC5 uses Bootstrap to style the scaffolded pages. While there isn't space to cover Bootstrap in depth in this book, you will use some of the features in Bootstrap in this chapter to add additional styling to your site.

The Fonts Folder

Bootstrap ships with GlyphIcons-Halflings font sets, which you will use later in this chapter to enhance your application UI. The version of Bootstrap that ships with the MVC project template requires that the fonts are located in the Fonts folder.

The Scripts Folder

The Scripts folder is where JavaScript files are placed. Table 34-7 lists the files that ship with the default template and their use.

Table 34-7. *JavaScript Files in the ASP.NET MVC Project Template*

| JavaScript File | Meaning in Life |
|--|--|
| <code>_references.js</code> | The <code>_references.js</code> file is for Visual Studio IntelliSense. You can add additional references into this file pointing to your custom JavaScript files. |
| <code>bootstrap.js</code> <code>bootstrap.min.js</code> | These are the JavaScript files for Bootstrap. The <code>.min</code> file is the pre-minified version. |
| <code>jquery-1.x.intellisense.js</code> <code>jquery-1.x.js</code> <code>jquery-1.x.min.js</code> <code>jquery-1.x.min.map</code> | jQuery is the dominant JavaScript framework for web developers. In addition to DOM manipulation capabilities, there are a host of frameworks that depend on jQuery, including the validation plug-in used in the MVC project template. The MVC project template ships with older versions of jQuery. In the next section, you will update them to the current version. |
| <code>jquery.validate-vsdoc.js</code> <code>jquery.validate.js</code> <code>jquery.validate.min.js</code> | The jQuery Validate plug-in makes client-side validation much simpler. The <code>vsdoc</code> file is for Visual Studio IntelliSense, and the <code>.min</code> file is the pre-minified version. |
| <code>jquery.validate.unobtrusive.js</code> <code>jquery.validate.unobtrusive.min.js</code> | The Unobtrusive jQuery Validation plug-in works with jQuery Validation, leveraging HTML5 attributes for client-side validation. |
| <code>modernizr-2.x.js</code> | Modernizr contains a series of fast tests (“detects” in Modernizr parlance) to determine browser capabilities. This works directly against the browser instead of relying on browser caps files that may or may not be out of date. |
| <code>respond.js</code> <code>respond.min.js</code> | Respond.js is an experimental jQuery plug-in for building web sites with responsive content. |

Updating NuGet Packages to Current Versions

As you can see, there are a *lot* of files and packages that comprise the core MVC project template, and many of them are open source frameworks. Open source projects get updated at a much more rapid pace than Microsoft can (or should) release updates to Visual Studio. It’s almost a guarantee that as soon as you create a new project, the packages are already out-of-date.

Fortunately, updating them is as simple as running the NuGet GUI. Right-click your project and select Manage NuGet Packages from the context menu. Once the NuGet Package Manager loads, change Filter to Installed, which will then show only the packages that are installed. Packages with a blue arrow pointing up have an upgrade available, as shown in Figure 34-6. Go ahead and update all your packages.

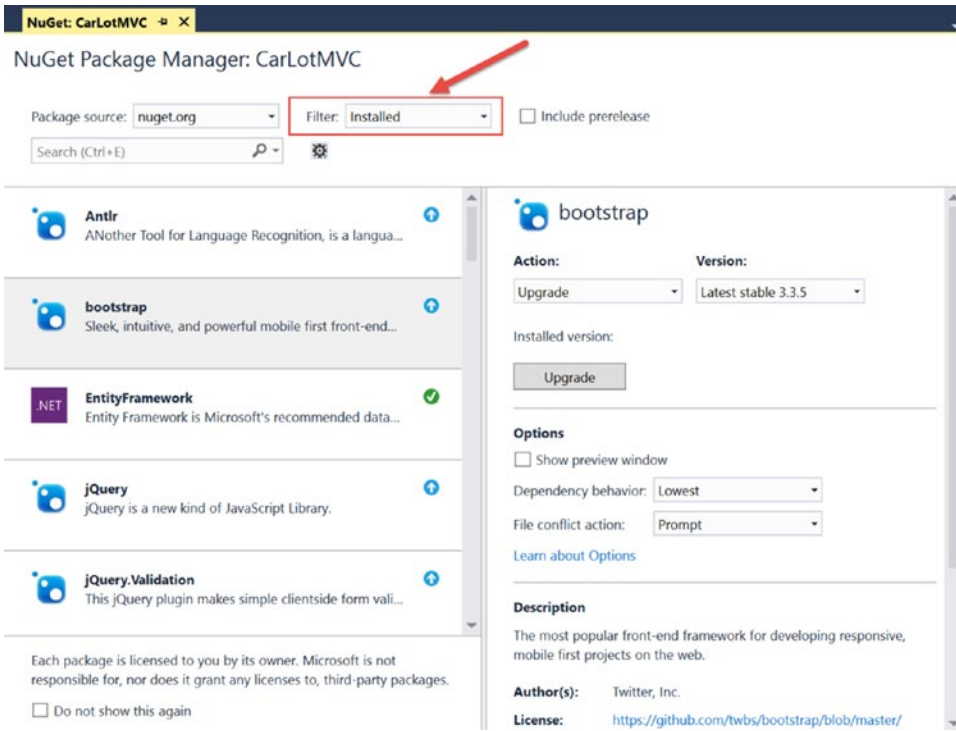

Figure 34-6. Updating NuGet packages

Test-Drive Your Site

Before you go any further into the chapter, run the project and click around to see what is included with the default project template. You will find that there is quite a lot already built for you. The template has a menu, several screens, and login capabilities (complete with a registration screen). Figure 34-7 shows the home page.

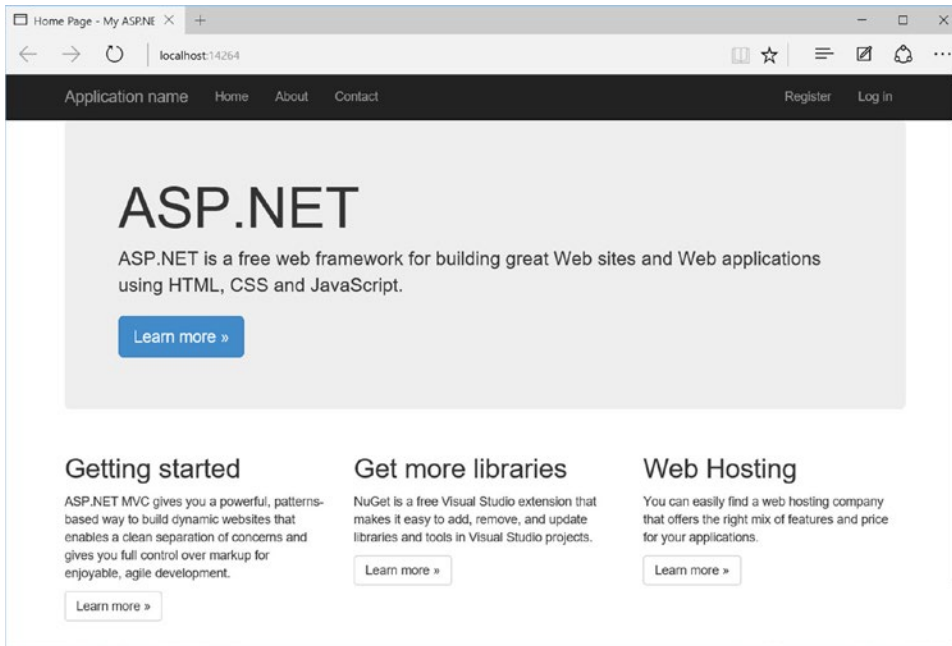

Figure 34-7. Default home page

As mentioned, Bootstrap is a *responsive* framework, which means it is capable of adapting the UI based on the viewport. Shrink the size of your browser, and you will see the home page alter to be more mobile friendly, as shown in Figure 34-8. The menu becomes the standard “cheeseburger” glyph, and the horizontal layout of the three “Learn more” sections change to vertical.

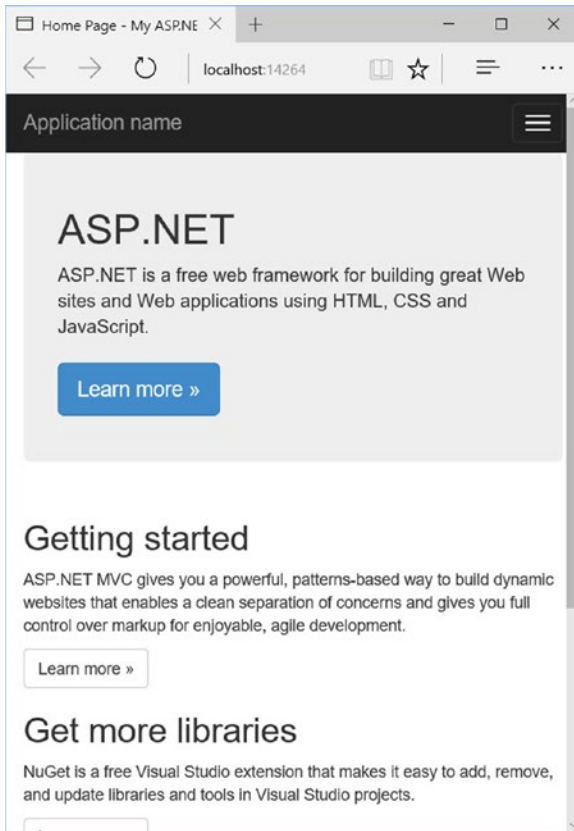

Figure 34-8. The responsive view of the home page

Routing

Routing is the way MVC matches URL requests to controllers and actions in your application, instead of the old Web Forms process of matching URLs to file structure. Run the CarLotMVC project again, and notice the URL is essentially blank. On my machine, the URL is `http://localhost:14264` (on your machine, the port number will most likely be different). Now click the Contact link, and the URL changes to `http://localhost:14264/Home/Contact`. Examining your solution, there isn't a folder path of `Home/Contact`. This is because the Route table mapped the URL request of `Home/Contact` to execute the `Contact()` action method on the `HomeController.cs` class. (You'll learn more about controllers and actions later in this chapter.)

URL Patterns

Routing entries are composed of URL patterns comprised of variable placeholders and literals placed into a collection known as the *route table*, with each entry defining a different URL pattern to match. Variable placeholders can be custom variables or from a list of predefined variables. For example, `{controller}` and `{action}` direct to a controller and action. The placeholder `{id}` is custom and is translated into a parameter for the action. When a URL is checked against the route table, the process is serial and ordered. It checks the URL against the entries in the collection in the order that they were added. The process stops when the

first match is found; it doesn't matter if a *better* match occurs later in the route table. This is an important consideration to keep in mind when adding route table entries.

Open `RouteConfig.cs` (located in the `App_Start` folder) and examine the contents, as shown here:

```
public class RouteConfig
{
    public static void RegisterRoutes(RouteCollection routes)
    {
        routes.IgnoreRoute("{resource}.axd/{*pathInfo}");

        routes.MapRoute(
            name: "Default",
            url: "{controller}/{action}/{id}",
            defaults: new { controller = "Home", action = "Index", id = UrlParameter.Optional }
        );
    }
}
```

The first line directs the routing engine to ignore requests that have an `.axd` extension, which denotes an `HttpHandler`. The `IgnoreRoute()` method passes the request back to the web server, in this case IIS. The `{*pathinfo}` pattern handles a variable number of parameters, extending the matches to any URL that includes an `HttpHandler`.

The `MapRoute()` method adds a new entry into the route table. The call specifies a name, URL pattern, and default values for the variables in the URL pattern. The URL pattern in the preceding example is the same as discussed earlier, calling the specified action on the specified controller and passing the `{id}` entry into the action method as a parameter. An example URL that would be serviced by this route is `Inventory/Add/5`. This invokes the `Add()` action method on the `InventoryController`, passing 5 to the `id` parameter.

The defaults specify how to fill in the blanks for partial URLs. In the previous code, if nothing was specified in the URL (such as `http://localhost:14264`), then the routing engine would call the `Index()` action method of the `HomeController` class, without any `id` parameter. The defaults are progressive, meaning that they can be excluded from right to left. Entering a URL like `http://localhost14264/Add/5` will fail the `{controller}/{action}/{id}` pattern.

Creating Routes for the Contact and About Pages

Of course, when your site is deployed, the URL won't be `localhost:14264` but something meaningful like `http://skimedic.com`. One of the advantages of routing is the ability to shape URLs to the benefit of your users. This means creating URLs that are easy to remember and find on search engines. For example, instead of `http://skimedic.com/Home/Contact` and `http://skimedic.com/Home/About`, it would be better to also be able to reach them with `http://skimedic.com/Contact` and `http://skimedic.com/About` (of course without losing the longer mapping). With routing, this is easy to accomplish.

Open `RouteConfig.cs`, and add the following line of code *after* the `IgnoreRoutes` call and *before* the default route:

```
routes.MapRoute("Contact", "Contact", new { controller = "Home", action = "Contact" });
```

This line adds a new entry named `Contact` into the route table that contains only one literal value, `Contact`. It maps to `Home/Contact`, not as defaults, but as hard-coded values. To test this, run the app, and click the `Contact` link. The URL changes to `http://localhost:14264/Contact`, which is exactly what you wanted—an easy-to-remember URL for your customers.

Now update the URL to `http://localhost:14264/Home/Contact/Foo`. It still works! This is because the URL failed to match the first entry in the route table and fell through to the second route entry, which it matched. Now update the URL in the browser to `http://localhost:14264/Home/Contact/Foo/Bar`. This time it fails, since it doesn't match any of the routes. Fix this by adding `{*pathinfo}` to the pattern. This allows any number of additional URL parameters. Update the Contact route entry to the following:

```
routes.MapRoute("Contact", "Contact/{*pathinfo}", new { controller = "Home",
action = "Contact" });
```

Now when you enter the URL `http://localhost:14264/Home/Contact/Foo/Bar`, it still shows the Contact page. Mission accomplished. This is an easy-to-remember URL for your users, and even if they mess it up by adding a bunch of additional garbage on the end, they can still find your page.

To complete the exercise, add the following line immediately after the Contact entry to create a route for the About page:

```
routes.MapRoute("About", "About/{*pathinfo}", new { controller = "Home", action = "About" });
```

Redirecting Users Using Routing

Another advantage of routing is that you no longer have to hard-code URLs for other pages in your site. The routing entries are used bi-directionally, not only to match incoming requests but also to build URLs for your site. For example, open the `_Layout.cshtml` file in the `Views/Shared` folder. Notice this line (don't worry about the syntax for now; you'll learn about it shortly):

```
@Html.ActionLink("Contact", "Contact", "Home")
```

The `ActionLink()` HTML helper creates a hyperlink with the display text *Contact* for the Contact action in the Home controller. Just like incoming requests, the routing engine starts at the top and works down until it finds a match. This line matches the Contact route you added earlier in the chapter and is used to create the following link:

```
<a href="/Contact">Contact</a>
```

If you hadn't added the Contact route, the routing engine would have been created this:

```
<a href="/Home/Contact">Contact</a>
```

■ **Note** This section introduced several new items that I haven't covered yet, such as the `@` syntax, the `Html` object, and the `_Layout.cshtml` file. These are all covered soon enough. The main takeaway is that the routing table is used not only to parse incoming requests and send them to the appropriate resource for handling but also to create URLs based on the resources specified.

Adding AutoLotDAL

Applications need data, and CarLotMVC is no different. Start by copying the AutoLotDAL project from Chapter 31 and all of its files into the CarLotMVC folder (at the same level as the CarLotMVC solution file). You can also copy the project from the Chapter 34 subfolder of the source download. You will be updating the data access library from what you built in Chapter 31, so you can't just reference the DLL.

Add the project into your solution by right-clicking the CarLotMVC solution, selecting Add ► Existing Project, navigating to the AutoLotDAL folder, and selecting AutoLotDAL.csproj. Add a reference to AutoLotDAL by right-clicking the CarLotMVC project and selecting Add ► Reference from the context menu. In the Reference Manager dialog, select Projects ► Solution in the left sidebar, check the box next to AutoLotDAL (as shown in Figure 34-9), and click OK.

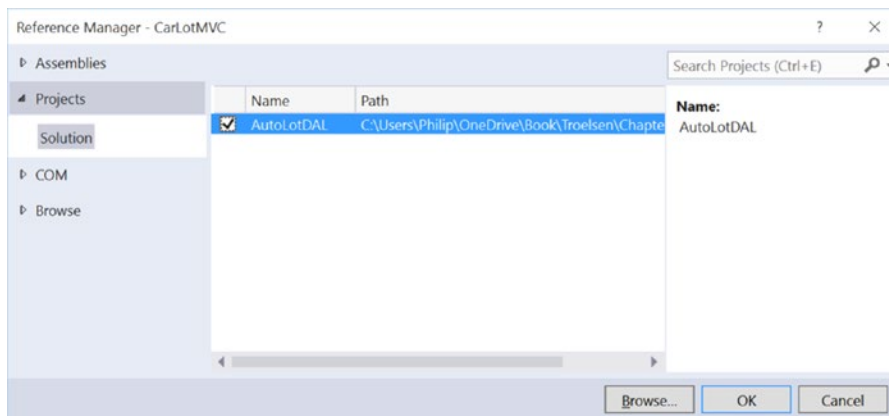

Figure 34-9. Adding the project reference for AutoLotDAL

The next step is to add the connection string to the AutoLot database into the CarLotMVC Web.config file. Since ASP.NET Identity uses Entity Framework (EF), you don't need to install the EF package like you did when building the Web Forms sites. You just need to add another connection string. Open the Web.config file and locate the <connectionStrings> element. Either copy the AutoLotConnection value from the App.config file in the AutoLotDAL project or manually add the AutoLotConnection value as shown here (your value might be slightly different than shown here based on how you installed SQL Server Express):

```
<connectionStrings>
  <!-- default connection omitted for brevity -->
  <add name="AutoLotConnection" connectionString="data source=localhost\
    SQLEXPRESS2014;initial catalog=AutoLot;integrated security=True;MultipleActive
    ResultSets=True;App=EntityFramework" providerName="System.Data.SqlClient" />
</connectionStrings>
```

Note You probably noticed that ASP.NET Identity uses LocalDb (a lightweight version of SQL Server that doesn't require administration) for the data source, and you can certainly use LocalDb with ASP.NET MVC projects (many developers do). Since this book uses the same database since Chapter 21 for all the data-driven examples, I decided to create a SQL Express database instead of using LocalDb. Does it make a difference in how you would build this site? No, it does not. The end result is the same, and I wanted to focus on C# and keep the SQL Server aspect simple and unobtrusive.

Controllers and Actions

As discussed earlier, when a request comes in from the browser, it (typically) gets mapped to an action method for a specific controller class. While that sounds fancy, it's pretty straightforward. A controller is a class that inherits from one of two abstract classes, `Controller` or `AsyncController`. Note that you can also create a controller from scratch by implementing `ApiController`, but that is beyond the scope of this book. An action method is a method of the controller class.

Adding the Inventory Controller

The best way to understand this is to add a new controller with actions using the built-in helpers in Visual Studio. Right-click the `Controllers` folder in your project, and select `Add > Controller`, as shown in Figure 34-10.

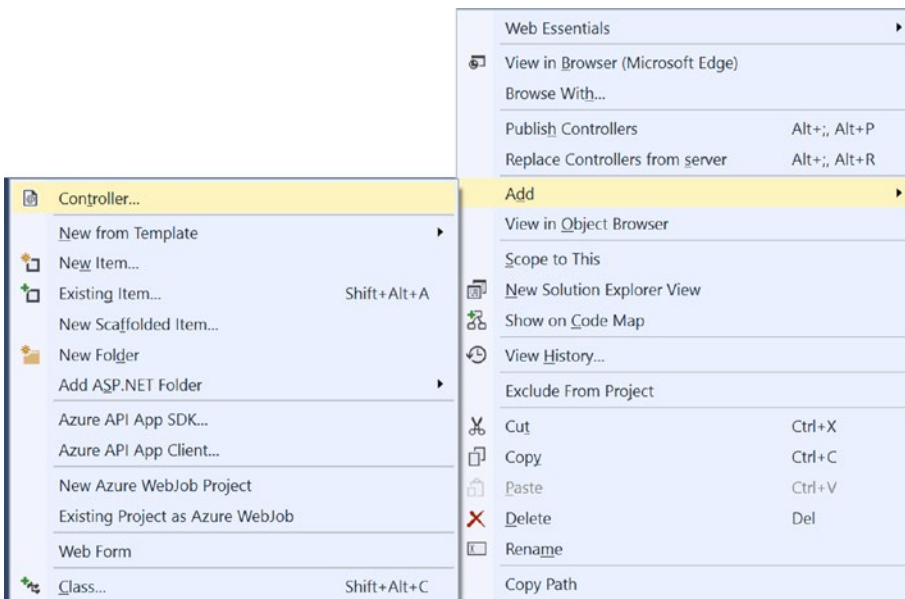

Figure 34-10. Launching the Add Scaffold dialog for a new controller

This brings up the Add Scaffold dialog, as shown in Figure 34-11. There are several options available, and you want to choose the “MVC5 Controller with views, using Entity Framework”

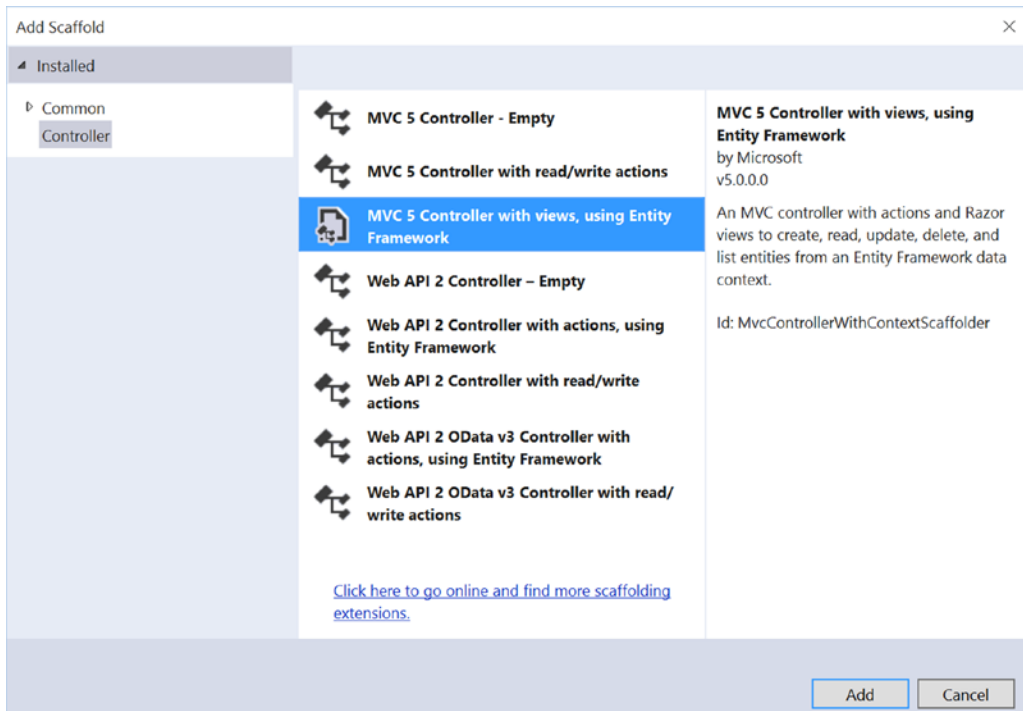

Figure 34-11. The Add Scaffold dialog

This will bring up an additional dialog (shown in Figure 34-12) that allows you to specify the types for your controller and action methods. The first question is to specify the model class, which determines the type for the controllers and action methods. Select the Inventory class from the drop-down. The next question asks you to specify the context class. If you don't select one, the wizard will create one for you. For the data context, select `AutoLotEntities`. The next option is to use async action methods. Select the option that best meets your project needs. For this example, select the “Use async controller actions” check box. The Generate Views option (on by default) instructs the wizard to create a related view for each of the action methods. The “Reference script libraries” option instructs include the render for jQuery validation. The “Use a layout page” option will be discussed later in this chapter. Leave those three (Generate Views, Reference script libraries, and Use a layout page) checked, and change the name to `InventoryController` (from `InventoriesController`).

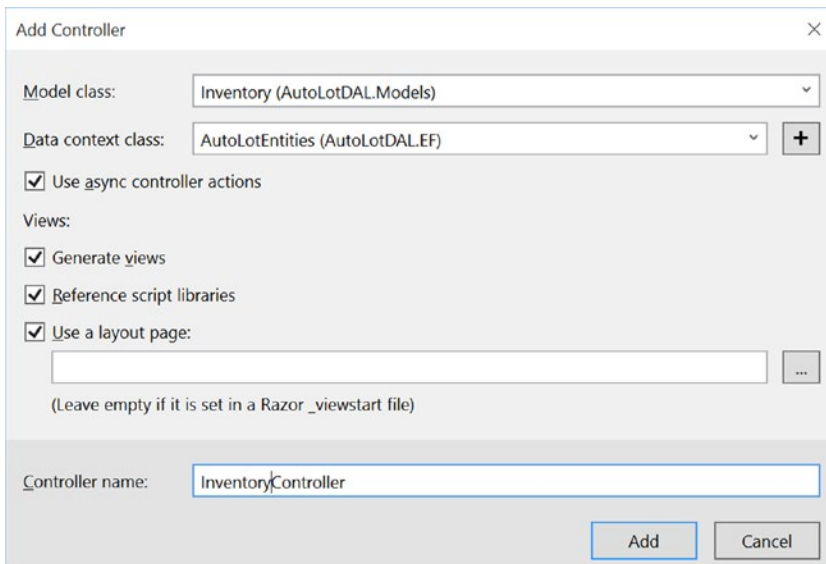

Figure 34-12. Selecting the model, context, and other options

■ **Note** There are a lot of MVC tooling aides in Visual Studio. You just saw how you can invoke the New Controller Wizard, which uses scaffolding to create a controller and a series of views (based on your answers in the wizard). If you right-click the Views folder, there is a menu item to add a new view, and the New View Wizard invokes the view scaffolding. If you right-click an action, you can add a new view (which will be placed in the Views/Controller folder with the same name as the action), or you can navigate to the proper view. All of these features depend on the conventions discussed earlier, so if you follow the rules, life will be good!

This does several things for you. First, it created an `InventoryController` class in the Controllers folder. It also created an `Inventory` folder in the Views folder and added five views under that folder. We will examine each of these in detail now.

Examine the Scaffolded Views

To access the new views without hacking the URL, you need to create a menu item for them. Open `_Layout.cshtml` (under Views/Shared), and locate the line containing `@Html.ActionLink(" Home", "Index", "Home")`. Make a copy of that line and paste it in just below. Update the line to the following:

```
<li>@Html.ActionLink("Inventory", "Index", "Inventory")</li>
```

Before you run the program, you need to change the startup settings for the project. Select the `CarLotMVC` project in Solution Explorer, right-click, and select Properties. Navigate to Web in the left sidebar, and select “Specific page” (leaving the value blank) under Start Action, as in Figure 34-13. This will cause Visual Studio to launch your site at the root (e.g., `http://localhost:14264`).

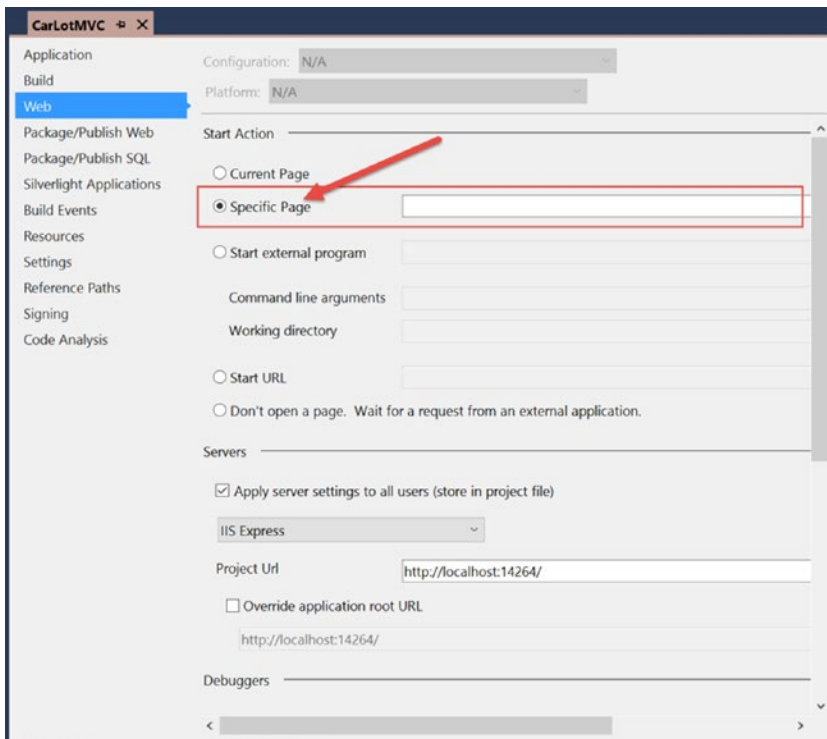

Figure 34-13. Updating the Web start action

Now run the program, click the Inventory link, and play around with viewing, editing, creating, and deleting cars. The views aren't going to win any design awards, but they are functional. You will upgrade the UI in the next section, but for now, let's examine the controller and actions in more detail.

MVC Controllers

Open the `InventoryController.cs` class. Notice that it follows the convention of ending in the word *Controller*. It also derives from the abstract class `Controller`. There are a series of methods (actions) such as `Index()`, `Edit()`, and so on. You will examine each of these in turn, as well as the attributes decorating them. Finally, there is a `Dispose()` override that you can use to forcefully garbage collect any expensive resources used by the controller.

Action Results

Actions typically return an `ActionResult` (or `Task<ActionResult>` for async operations). There are several types that derive from `ActionResult`, and some of the more common ones are listed in Table 34-8.

Table 34-8. *Typical ActionResult-Derived Classes*

| Action Result | Meaning in Life |
|---|---|
| ViewResult PartialViewResult | Returns a view (or a partial view) as a web page |
| RedirectResult RedirectToRouteResult | Redirects to another action |
| JsonResult | Returns a serialized JSON result to the client |
| FileResult | Returns binary file content to the client |
| ContentResult | Returns a user-defined content type to the client |
| HttpStatusCodeResult | Returns a specific HTTP status code |

Using the Inventory Repository

The first line in the `InventoryController` class creates a new instance of `AutoLotEntities`, which is exactly what you told the wizard to use. You need to change this to use the `InventoryRepo` class. Add an `InventoryRepo` instance variable at the top of the class like this:

```
private readonly InventoryRepo _repo = new InventoryRepo();
```

Next, dispose the instance in the `Dispose` override:

```
protected override void Dispose(bool disposing)
{
    if (disposing)
    {
        db.Dispose();
        _repo.Dispose();
    }
    base.Dispose(disposing);
}
```

The Index Action

The `Index` action gets all the `Inventory` records and returns the data to the view (more on views in the next section). Update the call to use the `InventoryRepo` class instead of calling into the `AutoLotEntities` class directly.

```
public async Task<ActionResult> Index()
{
    return View(await _repo.GetAllAsync());
}
```

The `View()` call in the previous code snippet is an overloaded method in the Controller base class and returns a new `ViewResult`. When a view name is not passed in (as in the version you just saw), convention dictates that the view will be named after the action method and located in the folder named after the controller, in this case, `Views/Inventory/Index.cshtml`. You can also change the name of the view and pass the new name into the `View()` method. For example, if you named your view `Foo.cshtml`, you would call the `View()` method as follows:

```
return View("Foo", await _repo.GetAllAsync());
```

The Details Action

The `Details()` action method returns all the details for one Inventory record. A URL in the format <http://mysite.com/Inventory/Details/5> will get mapped to the `InventoryController`, `Details()` action method, with a parameter named `id` and a value of 5. Update this method to call `_repo.GetOneAsync(id)` instead of the call to `AutoLotEntities` directly, like this:

```
// GET: Inventory/Details/5
public async Task<ActionResult> Details(int? id)
{
    if (id == null)
    {
        return new HttpStatusCodeResult(HttpStatusCode.BadRequest);
    }
    var inventory = await _repo.GetOneAsync(id);
    if (inventory == null)
    {
        return HttpNotFound();
    }
    return View(inventory);
}
```

There are a couple of interesting items in this simple-looking method. Remember from the route discussion that the `id` parameter is optional, so the URL `/Inventory/Details` will correctly map to this method. However, you can't get an Inventory record if there isn't an `id` value passed in to the method, so the method returns an `HttpStatusCode 400 (Bad Request)`. Try this by running the app and entering `Inventory/Details` (leaving off the `id` part of the URL), and you should see an error screen similar to Figure 34-14.

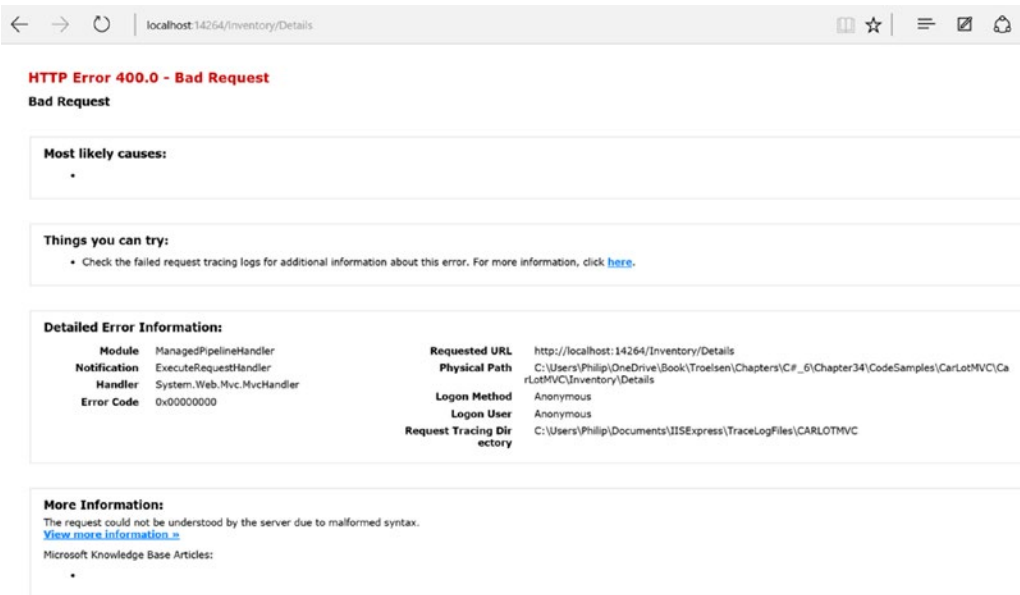

Figure 34-14. Returning the `HttpStatusCode (Bad Request)`

Likewise, if an inventory record cannot be found, the action method returns the `HttpNotFound (404)` status code.

Finally, if everything is good with the format of the URL and an Inventory record is found, then the `Views/Inventory/Details.cshtml` page is returned to the client.

The Create Action

Next, examine the `Create()` action method, and you will see two `Create()` methods; one takes no parameters, and the second takes an `Inventory` object as a parameter.

HttpGet

The `Create()` method without any parameters handles an `HttpGet` request, does not call into the database (which makes sense since the user is not creating a new record but retrieving one), and returns the `~/Views/Inventory/Create.cshtml` view.

```
// GET: Inventory/Create
public ActionResult Create()
{
    return View();
}
```

Don't worry about the view details yet; I will cover this soon.

HttpPost

The `Create()` overload that takes an `Inventory` object as its parameter (instantiated using implicit model binding) has two method-level attributes, `[HttpPost]` and `[ValidateAntiForgeryToken]`, and one parameter-level attribute, `[Bind]`. This version is executed when a user has clicked the submit button of the `Create` form (presuming all client-side validations pass).

Model Binding

As a refresher from Chapter 32, model binding takes all the form, query string, and so on, name-value pairs and attempts to reconstitute a specified type using reflection. There is explicit model binding and implicit model binding. In each case, the model binding engine attempts to assign the values (from the name-value pairs in the submitted form values) to the matching properties on the desired type. If it can't assign one or more values (e.g., because of data type conversion issues or validation errors), it will set `ModelState.IsValid = false`. If all matched properties are successfully assigned, it sets `ModelState.IsValid = true`. In addition to the `IsValid` property, the `ModelState` is a `ModelStateDictionary` and contains error information for every property that failed, as well as model-level error information. If you want to add a specific error for a property, you would write code like this:

```
ModelState.AddModelError("Name", "Name is required");
```

If you want to add an error for the entire model, use `string.Empty` for the property name, like this:

```
ModelState.AddModelError(string.Empty, $"Unable to create record: {ex.Message}");
```

For explicit model binding, you call `TryUpdateModel()`, passing in an instance of the type. If the model binding fails, the `TryUpdateModel()` call returns `false`. For example, you could write the `Create()` method this way:

```
public async Task<ActionResult> Create()
{
    var inv = new Inventory();
    if (TryUpdateModel(inv))
    {
        //Save the data
    }
}
```

For implicit model binding, you use the desired type as the parameter for the method. The model binding engine does the same operation with the parameter as it did with `TryUpdateModel()` in the previous example.

```
public async Task<ActionResult> Create(Inventory inventory)
{
    if (ModelState.IsValid)
    {
        //Save the data;
    }
}
```

HttpPost vs. HttpGet

While ASP.NET Web Forms largely ignored the difference between `HttpGet` and `HttpPost`, MVC uses the HTTP verbs appropriately. The Hypertext Transfer Protocol (HTTP) defines an `HttpGet` call as requesting data from the server and an `HttpPost` call as one that submits data to be processed to a specific resource.

In MVC, any action *without* an HTTP attribute (such as `HttpPost`) will be executed as an `HttpGet` operation. To specify an `HttpPost` (an action where data will be submitted and potentially updated), you must decorate your action with the `[HttpPost]` attribute.

AntiForgery Tokens

One of a number of weapons to fight hacking, `AntiForgeryToken` is a form value that is added into your views. When an `HttpPost` request comes in, the token is validated as long as the `[ValidateAntiForgeryToken]` attribute is present. While not a one-stop shop for security (web security is beyond the scope of this book), every form should add an `AntiForgeryToken`, and every `HttpPost` action should validate it.

The Bind Attribute

The `Bind` attribute in the `Create()` and `Edit()` action methods allows you to white list or black list or add a prefix for properties (not covered in this chapter). When fields are *white listed*, they are the only fields that will be assigned through model binding, helping to protect your data from a user over-posting data. *Black listing* excludes properties from model binding. In the `Create()` method, all the fields are white listed, but you want only `Make`, `Color`, and `PetName` to be submitted. Remove the `CarId` and `Timestamp` fields from the `Include` portion, as follows:

```
public async Task<ActionResult> Create([Bind(Include = "Make,Color,PetName")] Inventory inventory)
```

And Now the Code...

If the model state isn't valid, the method sends the `Create` view back to the user with the current data, giving them an opportunity to correct any erroneous data. If the model state is indeed valid and the values are successfully saved by the repository, the action method returns a `RedirectToAction`, which redirects the user to the `Index` action method of the inventory controller. The redirection to the `Index` view after a successful save prevents the user from clicking the `Create` button again, which would cause a double post. If there is an error thrown during the save process, a new `ModelError` is added to the `ModelState`, and the user is sent back to the `Create` page to try again. Note: I like to flip the initial `if` statement around to make the method more readable. The final change is to use the `AddAsync()` method of the repo. The updated code should look like this:

```
[HttpPost][ValidateAntiForgeryToken]
public async Task<ActionResult> Create([Bind(Include = " Make,Color,PetName")] Inventory
inventory)
{
    if (!ModelState.IsValid) { return View(inventory); }
    try
    {
        await _repo.AddAsync(inventory);
        return RedirectToAction("Index");
    }
}
```

```

catch (Exception ex)
{
    ModelState.AddModelError(string.Empty, $"Unable to create record: {ex.Message}");
    return View(inventory);
}
}

```

The Edit Action

Just like the `Create()` action method, the `Edit()` action method has two methods: one that handles an `HttpGet` request and one that handles an `HttpPost` request.

HttpGet

The first `Edit()` method takes an `id` and is identical to the `Details()` `HttpGet` method. Make sure to change the method to use the `Inventory` repository instead of `AutoLotEntities`.

```

public async Task<ActionResult> Edit(int? id)
{
    if (id == null)
    {
        return new HttpStatusCodeResult(HttpStatusCode.BadRequest);
    }
    Inventory inventory = await _repo.GetOneAsync(id);
    if (inventory == null)
    {
        return HttpNotFound();
    }
    return View(inventory);
}

```

HttpPost

Just like the `Create()` action method, this version is executed when a user has clicked the submit button of the Edit form (presuming all client-side validations pass). If the model state isn't valid, the method once again returns the Edit view, sending the current values for the `Inventory` object. If the model state is valid, the `Inventory` object is sent to the repository for an attempted save. In addition to the general error handling (like you used in the `Create()` method), you also need to add a check for `DbUpdateConcurrencyException`, which will occur if another user has updated the record since the user originally loaded it into the web page. If all is successful, the action method returns a `RedirectToAction` result, sending the user to the `Index()` action method of the `InventoryController`.

The `Bind` attribute can stay the same since all the values need to come from the form, but change the method to use the `AddAsync()` method of the repo, as follows:

```

[HttpPost][ValidateAntiForgeryToken]
public async Task<ActionResult> Edit(
    [Bind(Include = "CarId,Make,Color,PetName,Timestamp")] Inventory inventory)
{
    if (!ModelState.IsValid) { return View(inventory); }
}

```

```

try
{
    await _repo.SaveAsync(inventory);
    return RedirectToAction("Index");
}
catch (DbUpdateConcurrencyException)
{
    ModelState.AddModelError(string.Empty, "Unable to save record. Another user updated
the record.");
}
catch (Exception ex)
{
    ModelState.AddModelError(string.Empty, $"Unable to save record: {ex.Message}");
}
return View(inventory);
}

```

■ **Note** As you saw in Chapter 23, `DbUpdateConcurrencyException` provides a lot of information to you, the developer. Because of space constraints, leveraging that capability in this chapter won't be demonstrated.

The Delete Action

The `Delete()` action method also has two methods: one that handles an `HttpGet` request and one that handles an `HttpPost` request.

HttpGet

The first `Delete()` method takes an `id` and is identical to the `Details()` and `Edit()` `HttpGet` methods. Make sure to change the `HttpGet` version to use the `Inventory` repository instead of `AutoLotEntities`.

```

public async Task<ActionResult> Delete(int? id)
{
    if (id == null)
    {
        return new HttpStatusCodeResult(HttpStatusCode.BadRequest);
    }
    Inventory inventory = await _repo.GetOneAsync(id);
    if (inventory == null)
    {
        return HttpNotFound();
    }
    return View(inventory);
}

```

HttpPost

This version is executed when a user has clicked the submit button of the Delete form. The autogenerated version of this method takes only the `id` as a parameter, meaning it has the same signature as the `HttpGet` version of the method. Since you can't have two methods of the same name with the same signature, the wizard named this method `DeleteConfirmed()` and added the `[ActionName("Delete")]` attribute. `AutoLotDAL` checks for concurrency conflicts and requires the `Timestamp` property in addition to the `CarId` in order to delete a record. You also want an `Inventory` instance to show any model errors. To accommodate these needs, simply change the `int id` parameter to `Inventory inventory`. This change will use implicit model binding to get the `Inventory` record values from the request.

To delete a record, you only need the `CarId` and `Timestamp` properties. Add a `[Bind]` attribute with the `Include` value of `"CarId,Timestamp"` to pull those values into the `Inventory` instance and ignore the rest of the values. Now that the method signature has changed from the `HttpGet` version, you can rename the method `Delete()` and remove the `ActionName` attribute. Finally, update the method to use the `DeleteAsync()` method of the `Inventory` repository and add the error handling (the same as you did for the `HttpPost` version of the `Edit()` method). The final version of the code is as follows:

```
[HttpPost]
[ValidateAntiForgeryToken]
public async Task<ActionResult> Delete([Bind(Include="CarId,Timestamp")]Inventory inventory)
{
    try
    {
        await _repo.DeleteAsync(inventory);
        return RedirectToAction("Index");
    }
    catch (DbUpdateConcurrencyException)
    {
        ModelState.AddModelError(string.Empty, "Unable to delete record. Another user updated
        the record.");
    }
    catch (Exception ex)
    {
        ModelState.AddModelError(string.Empty, $"Unable to create record: {ex.Message}");
    }
    return View(inventory);
}
```

If you ran your project now and tried to delete an `Inventory` record, it wouldn't work, because the view is not sending the `Timestamp` property, just the `CarId`. You will fix that shortly.

The Dispose Method

Finally, in the `Dispose()` method, delete the disposal of the `AutoLotEntities` variable (`db`) and then delete the class-level variable for `AutoLotEntities`. Your cleaned up `Dispose()` method should look like this:

```
protected override void Dispose(bool disposing)
{
    if (disposing)
    {
        _repo.Dispose();
    }
    base.Dispose(disposing);
}
```

The Final Word on Controllers

This was a lot of information to cover, and (like with routing) we've only scratched the surface of everything that you can do in MVC controllers and action methods. However, to distill it all down, controllers are merely C# classes. They should follow the `<Name>Controller.cs` naming convention (the `Controller` part of the name gets stripped away by the framework). Actions are methods in a controller class that return an `ActionResult`. Action methods can be decorated with an attribute that indicates if it's an `HttpPost` or an `HttpGet` (the default), and all `HttpPost` methods should validate the `AntiForgery` token. Now, let's move onto views.

MVC Views

Views in MVC represent the UI in MVC sites. Initially, MVC views were built using the Web Forms View Engine. Now, you have the choice of using the Razor View Engine or the Web Forms View Engine, although the majority of MVC sites are built using Razor. MVC views are meant to be very lightweight, passing server-side processing to the controllers and client-side processing to JavaScript.

The Razor View Engine

The Razor View Engine was designed as an improvement over the Web Forms View Engine and uses Razor as the core language. Razor is template markup syntax that is interpreted to C# (or VB.NET code) on the server side. Using Razor in your views with HTML and CSS results in cleaner and easier-to-read markup. While there are many improvements with using Razor in your views, views based on Razor still support everything you would expect from a web form.

Razor Syntax

The first difference between the Web Forms View Engine and the Razor View Engine is that you add code with the `@` symbol. There is also intelligence built into Razor that removes the need add closing `@` symbols, unlike Web Forms, which required opening and closing "nuggets" (`<% %>`).

Statement blocks open with an `@` and are enclosed in braces, like this (notice how there isn't an `@` used as a statement terminator):

```
@foreach (var item in Model)
{
}
```

Code blocks can intermix markup and code. Lines that begin with a markup tag are interpreted as HTML, while lines that begin with code are interpreted as code, like this:

```
@foreach (var item in Model)
{
    int x = 0;
    <tr></tr>
}
```

Lines can also intermix markup and code, like this:

```
<h1>Hello, @username</h1>
```

The `<text>` tag denotes text that should be rendered as part of the markup, like this:

```
@item<text>-<text>
```

The `@` sign in front of a variable is equivalent to `Response.Write()`, and by default HTML encodes all values. If you want to output unencoded data (i.e., potentially unsafe data), you have to use the `@Html.Raw(username)` syntax.

Helpers, Functions, and Delegates

Razor enables encapsulation of code to enhance your productivity and reduce the amount of repetitive code. You can place these inline, in the `App_Code` folder, or as statics.

HTML Helpers

Razor HTML helpers render markup. There are many built-in helpers that you will use extensively, such as `@Html.ActionLink()` that you used earlier for the inventory screens. You can also build your own HTML helpers to reduce (or eliminate repetitive code). For example, you can write a helper that outputs the details for an Inventory record. To do this, put the following HTML helper code at the top of the `Index.cshtml` view file (after the `@model` line), like this:

```
@using AutoLotDAL.Models
@helper ShowInventory(Inventory item)
{
    @item.Make<text>-</text>@item.Color<text>(</text>@item.PetName<text>)</text>
}
```

After the `@foreach`, add a call to `ShowInventory()`, like this:

```
@foreach (var item in Model)
{
    @ShowInventory(item)
    <!-- rest removed for brevity -->
}
```

Run the app, navigate to the Inventory index page, and you will see the details for each record as one lone string. In a real HTML helper, you would add formatting and markup to be consistent with the look and feel of your site. Since this is just an example of how to create an HTML helper and not something you want to use in your site, comment out the line using Razor comments, which are `@* ... *@`, like this:

```
@*@ShowInventory(item)*@
```

Razor Functions

Razor functions do not return markup but instead are used to encapsulate code for reuse. To see this in action, add the following `SortCars()` function after the HTML helper in the `Index.cshtml` view page. The function takes a list of Inventory items and sorts them by `PetName`:

```
@functions
{
    public IList<Inventory> SortCars(IList<Inventory> cars)
    {
        var list = from s in cars orderby s.PetName select s;
        return list.ToList();
    }
}
```

Update the `@foreach` to call the function. The `Model` variable represents an `IEnumerable<Inventory>`, so you must add the `ToList()` method in that call, as follows:

```
@foreach (var item in SortCars(Model.ToList()))
{
    <!-- rest removed for brevity -->
}
```

Razor Delegates

The final example shows Razor delegates, which work just like C# delegates. For example, add the following delegate code immediately after the `SortCars()` function in the `Index.cshtml` view file. This delegate makes the marked characters bold.

```
@{
    Func<dynamic, object> b = @<strong>@item</strong>;
}
```

To see this in action, add the following line of code immediately after the code block that defines the delegate:

```
This will be bold: @b("Foo")
```

Of course, this example is trivial, but more involved code that is repeated can benefit by being wrapped in a delegate. Essentially, all the same procs and cons for C# delegates apply. After running the app and navigating to the Inventory index page, you will see the word *Foo* in bold. Go ahead and comment out the call to the delegate since you don't need it for the rest of the samples.

The Final Word on Razor

Once again, you have to move on to a new subject because there just isn't enough space in this book to detail everything that you can do with Razor. You will see more examples of Razor as you work through the rest of this chapter. This section gave you the foundation you need to expand your knowledge.

Layouts

Similar to Web Forms master pages, MVC supports layouts. MVC views can be based on a master layout to give the site a universal look and feel. Recall from Figure 34-12, there is a check box that says "Use a layout page." Leave the text box empty if it's specified in the `_ViewStart.cshtml` file. Also recall, from the information in the Views folder, there is a file named `_ViewStart.cshtml`. Open this file now to examine the contents, shown here:

```
@{
    Layout = "~/Views/Shared/_Layout.cshtml";
}
```

This file just has one Razor code block that sets the layout to a specific file. This is the fallback value; if a layout is not specified in a view, this is the file that will be used by default for the view.

Navigate to the Views/Shared folder and open the `_Layout.cshtml` file. It is a full-fledged HTML file, complete with `<head>` and `<body>` tags and a mix of HTML markup and Razor HTML helpers. Just like Web Forms master pages, the `_Layout.cshtml` page is the core of what will be presented to the user when views (that use the `_Layout.cshtml` page) are rendered.

There are two key items to keep in mind when working with layouts: body and sections. The body is where the view code will be inserted when the view and layout are combined. Where the view page content is placed in the layout is controlled by the following line of Razor code:

```
@RenderBody()
```

Sections are areas of the layout page that layouts can fill in at runtime. They can be required or optional and are introduced into the layout page with `RenderSection()`. The first parameter names the section, and the second parameter indicates whether the section is required to be implemented by the view. In `_Layout.cshtml`, the following line of code creates a section named `scripts`, which is optional for the view:

```
@RenderSection("scripts", required: false)
```

Sections can also be marked as required by passing in `true` as the second parameter. For example, if you wanted to create a new section named `Header` that is required, you would code it like this:

```
@RenderSection("Header",required: true)
```

To render a section in from your view, you use the `@section` Razor block. For example, in the `Edit.cshtml` page under `Views/Inventory`, the following lines add the jQuery validation bundle to the rendered page:

```
@section Scripts {
    @Scripts.Render("~/bundles/jqueryval")
}
```

Using a Specific Layout Page

In addition to relying on the default layout page, you can specify your views to use a specific page. To show this, copy `_Layout.cshtml` into a new file called `_LayoutNew.cshtml`. Open this new file, and just after the `<body>` tag, add the following line:

```
<div class="jumbotron">
    <h1>My MVC Application</h1>
</div>
```

Now, open `Index.cshtml` under `Views/Inventory`, and add `Layout="~/Views/Shared/_LayoutNew.cshtml"`, just after the `ViewBag` line. The updated code block should look like this:

```
@{
    ViewBag.Title = "Index";
    Layout = "~/Views/Shared/_LayoutNew.cshtml";
}
```

This line directs the view to use the new file as the layout file. Run the app and click the Inventory menu, and you will see the screen shown in Figure 34-15.

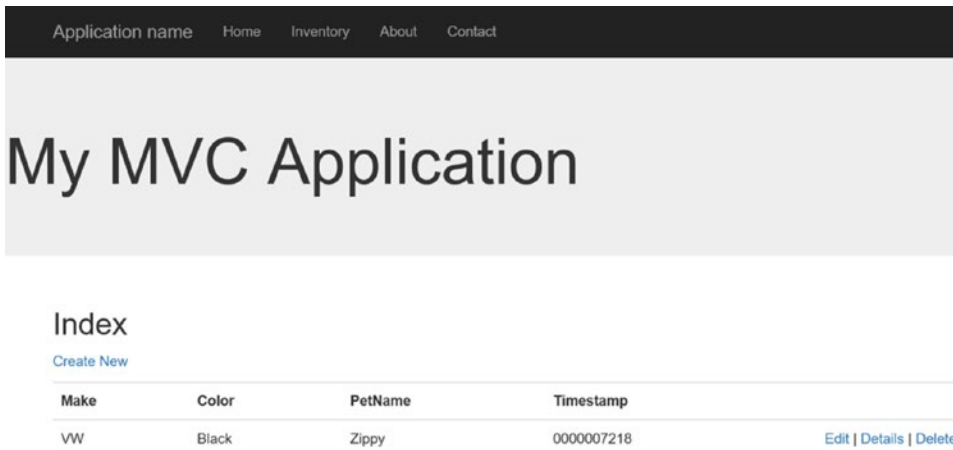

Figure 34-15. The Index view with the new layout

Partial Views

Partial views are useful for encapsulating UI, which reduces (or eliminates) repeating code. Since Razor views do not inherit `System.Web.Page` (and there's no `Page` directive), the only *technical* difference between a partial view and a regular view is how it's rendered from the action method. A full view (returned from a controller with the `View()` method) will use a layout page if one is specified, either as the default through `_ViewStart.cshtml` or through the `Layout` Razor statement. A view when rendered with the `PartialView()` method (or the `Partial()` HTML helper) does not use the default layout, but will still use a layout if specified with a `Layout` Razor statement.

To demonstrate this, open the `InventoryController.cs` class and change the `Index()` action method to return a partial view instead of a view, as follows:

```
public async Task<ActionResult> Index()
{
    return PartialView(await _repo.GetAllAsync());
}
```

Now open the `Index.cshtml` page and either remove the `Layout=` line that you added above or comment it out, like this:

```
@{
    ViewBag.Title = "Index";
    //Layout = "~/Views/Shared/_LayoutNew.cshtml";
}
```

Run the app and click the Inventory menu link. You will then see the same data as you did before, minus any layout, as in Figure 34-16.

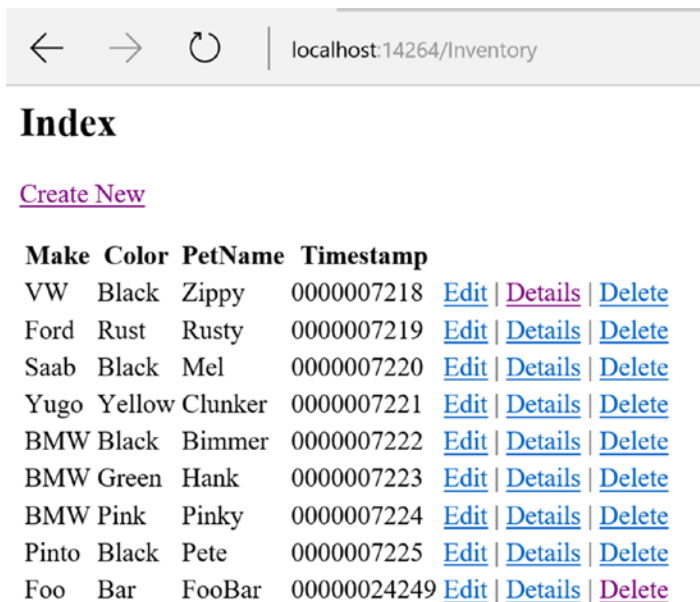

The screenshot shows a web browser window with the address bar displaying `localhost:14264/Inventory`. The page content is as follows:

[Create New](#)

| Make | Color | PetName | Timestamp | |
|-------|--------|---------|-------------|---|
| VW | Black | Zippy | 0000007218 | Edit Details Delete |
| Ford | Rust | Rusty | 0000007219 | Edit Details Delete |
| Saab | Black | Mel | 0000007220 | Edit Details Delete |
| Yugo | Yellow | Clunker | 0000007221 | Edit Details Delete |
| BMW | Black | Bimmer | 0000007222 | Edit Details Delete |
| BMW | Green | Hank | 0000007223 | Edit Details Delete |
| BMW | Pink | Pinky | 0000007224 | Edit Details Delete |
| Pinto | Black | Pete | 0000007225 | Edit Details Delete |
| Foo | Bar | FooBar | 00000024249 | Edit Details Delete |

Figure 34-16. The inventory Index page rendered as a partial view

Make sure to change the Index action method back to calling `View()` instead of `PartialView()`. You can leave the `//Layout = "~/Views/Shared/_LayoutNew.cshtml"` line commented out so the Index view returns to using the default layout.

In addition to rendering a view from an action method with the `PartialView()` method, you can pull in a partial view into another view using an HTML Helper, similar to loading a user control in Web Forms. In the `_Layout.cshtml` page, the following Razor block creates the login UI shown in every page.

```
@Html.Partial("_LoginPartial")
```

Sending Data to the View

As discussed earlier in the chapter, the MVC pattern relies on a certain level of separation of concerns. The controller sends data to the view, the view requests actions, and the models get passed around as the data for the application. I've already covered how views request actions, but I haven't yet discussed how to get data (the models) into the views.

ViewBag, ViewData, and TempData

The `ViewBag`, `ViewData`, and `TempData` objects are mechanisms for sending small amounts of data into a view. An example of this is in the top of each of the Inventory views with a line setting the `ViewBag.Title` property, like the following in the `Index.cshtml` view:

```
@{
    ViewBag.Title = "Index";
}
```

The `ViewBag.Title` is used to send the title of a view to the layout to be used in the following line in `_Layout.cshtml`:

```
<title>@ViewBag.Title - My ASP.NET Application</title>
```

Table 34-9 lists the three mechanisms to pass data from a controller to a view (besides the `Model` property, described in the next section) or from a view to a view.

Table 34-9. Ways to Send Data to a View

| Data Transport Object | Meaning in Life |
|-----------------------|--|
| <code>TempData</code> | This is a short-lived object that works during the current request and next request only. |
| <code>ViewData</code> | A dictionary that allows storing values in name-value pairs. Here's an example: <code>ViewData["Title"] = "Foo"</code> . |
| <code>ViewBag</code> | Dynamic wrapper for the <code>ViewData</code> dictionary. Here's an example: <code>ViewBag.Title = "Foo"</code> . |

Strongly Type Views and View Models

For larger amounts of data (such as all `Inventory` records used by the `Index.cshtml` view), you use the `Model` property. Examine the first line of the `Index.cshtml` file, and you will see this line, which indicates the view is strongly typed, with the type set to `IEnumerable<Inventory>`:

```
@model IEnumerable<AutoLotDAL.Models.Inventory>
```

The `@model` attribute represents the view's type. To access this in the rest of the view, you use the `Model` property. Note the uppercase `M` in the `Model` property and the lowercase `m` in the initial attribute. When referring to the data contained in the view, you use `Model` (capital `M`), as in the following line, which iterates through each of the `Inventory` records:

```
@foreach (var item in Model)
{
    //Do something interesting here
}
```

The Index View

Now it's time to start digging into the actual views. Open `Index.cshtml`, and examine the following code:

```
@Html.DisplayNameFor(model => model.Make)
```

This uses the `DisplayNameFor()` HTML helper to show the display name (as plain text) for the model field referenced in the lambda. In this example, the code gets the display name for the `Make` property of the `Inventory` object.

This works fine for `Make` and `Color`, but `PetName` is displayed as "PetName." You would rather have it display as "Pet Name." You could change the code and hard-code the words *Pet Name*, but this fixes the problem only for this particular view. Any other view that needs to display the `PetName` field would also have to have this label hard-coded. A better method is to use data annotations on the model to set the display name. You will do this shortly.

Since the users don't want to see the timestamp values, delete the header for the timestamp, including the markup and the Razor code. Also delete the timestamp code in the `for`-loop.

Inside the `for`-loop, the values for each item are displayed using another HTML helper, `DisplayFor()`. This HTML helper looks at the data type and presents the value based on the default template for that datatype. In this example, the data fields are strings, so the HTML helper just displays the values.

MVC Display Data Annotations

In addition to the data annotations used to define the model so Entity Framework can create the database (as used in Chapter 23), there are additional data annotations that you can use to define display properties. While you can add these to the model classes themselves, if you used EF to create your model classes from an existing database, any changes you make would be overwritten if you needed to regenerate your models. To prevent this, you can put your data annotations into another file.

Start by navigating to the Models folder in the AutoLotDAL project and add a new folder named Metadata. In this folder, add a new class named InventoryMetadata.cs. Make the class public, and add a property of type string named PetName. To this property, add the [Display(Name="Pet Name")] attribute. Your class should look like this:

```
public class InventoryMetadata
{
    [Display(Name="Pet Name")]
    public string PetName;
}
```

This is not a full class definition file; it will be used only to load attributes that you have assigned. Therefore, you do not need to add the get/set syntax to this property, and in fact, you shouldn't. You might be asking how the framework knows that this class is supplying attributes to the Inventory class. Currently, it doesn't. You need to add a class-level attribute to the Inventory.cs class so the framework knows this class holds additional attributes for it. You'll make that change next.

Open the InventoryPartial.cs class in the Models/Partials folder, and add the [MetadataType] attribute to the class, as follows:

```
[MetadataType(typeof(InventoryMetadata))]
public partial class Inventory
{
    public override string ToString() =>
        $"{this.PetName ?? "***No Name**"} is a {this.Color} {this.Make} with ID {this.CarId}.";
}
```

Run the app now, click the Inventory link, and you will see that the PetName label is displayed as "Pet Name," without changing any code in the view.

Updating the View with Bootstrap

The next step is to jazz up the Index.cshtml view a bit using Bootstrap.

Update the Header

The first thing to do is update the page header. The generated view has the header of "Index," which isn't very meaningful. Delete the <h2>Index</h2> line, and replace it with the following, which creates a small shaded area housing the page header. The markup looks like this:

```
<div class="well well-sm"><h1>Available Inventory</h1></div>
```

Figure 34-17 shows the result.

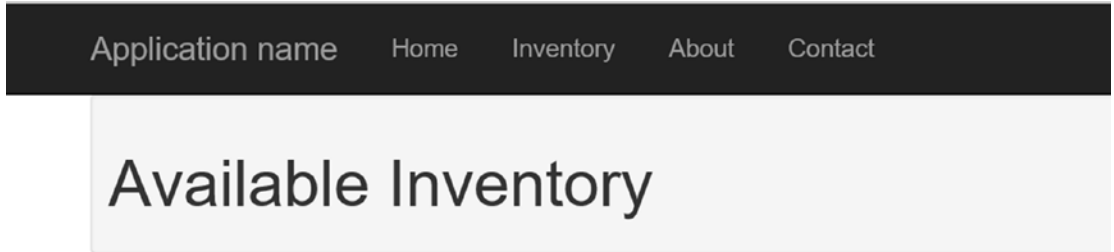

Figure 34-17. *Placing a header into a well*

Update the Table

Next, you will update the table. The default table class in Bootstrap adds some rudimentary design elements, including separator lines. There are additional built-in styles that you can add, as shown in Table 34-10.

Table 34-10. *Table-Style Options*

| Style | Meaning in Life |
|-------------------|--|
| .table | This is the base table style. It adds divider lines and light padding. |
| .table-striped | This adds striping to the table (think a green bar). Not available in Internet Explorer 8. |
| .table-bordered | This adds borders around every cell in the table. |
| .table-hover | This adds hover highlighting to the table. |
| .table-condensed | This cuts cell padding in half. |
| .table-responsive | Makes the table more responsive on mobile devices. |

Add all of them to the <table> class attribute except for table-condensed, and on the next line add a <caption> tag with the text “Vehicle List” as follows:

```
<table class="table table-striped table-responsive table-hover table-bordered">
  <caption>Vehicle List</caption>
```

Figure 34-18 shows the resulting UI.

Vehicle List

| Make | Color | Pet Name | |
|-------|--------|----------|---|
| VW | Black | Zippy | Edit Details Delete |
| Ford | Rust | Rusty | Edit Details Delete |
| Saab | Black | Mel | Edit Details Delete |
| Yugo | Yellow | Clunker | Edit Details Delete |
| BMW | Black | Bimmer | Edit Details Delete |
| BMW | Green | Hank | Edit Details Delete |
| BMW | Pink | Pinky | Edit Details Delete |
| Pinto | Black | Pete | Edit Details Delete |
| Foo | Bar | FooBar | Edit Details Delete |

Figure 34-18. The updated table UI

Using GlyphIcons

The GlyphIcons are a set of icons that ship with Bootstrap and are useful to add visuals to links and buttons. You are going to add icons to all the links on the Index view, but first it helps to explore another HTML helper: `@Url.Action()`. The `@Url.Action()` helper returns *just* the URL portion, whereas `Html.ActionLink()` creates the entire markup for an anchor tag.

Update the `@Html.ActionLink("Create")` line to this:

```
<a href="@Url.Action("Create")">Create a new Car</a>
```

This creates the same URL as the `ActionLink`, but now you have complete control of the markup. Next, add the “plus” `GlyphIcon` to the content of the anchor tag, like this:

```
<a href="@Url.Action("Create")">
    <span class="glyphicon glyphicon-plus"></span>&nbsp;&nbsp;&nbsp;Create
    a new Car
</a>
```

Figure 34-19 shows the updated link.

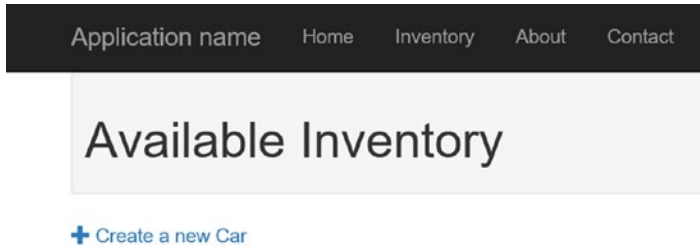

Figure 34-19. The Create a new Car link with the plus GlyphIcon

Next, update the Edit, Details, and Delete links in the table to use the Edit, List-Alt, and Trash GlyphIcons, respectively. This is shown in the following code listing:

```
<a href="@Url.Action("Edit", new {id = item.CarId})">
  <span class="glyphicon glyphicon-edit"></span>&nbsp;&nbsp;Edit
</a>
&nbsp;&nbsp;|&nbsp;&nbsp;
<a href="@Url.Action("Details", new {id = item.CarId})">
  <span class="glyphicon glyphicon-list-alt"></span>&nbsp;&nbsp;Details
</a>
&nbsp;&nbsp;|&nbsp;&nbsp;
<a href="@Url.Action("Delete", new {id = item.CarId})">
  <span class="glyphicon glyphicon-trash"></span>&nbsp;&nbsp;Delete
</a>
```

Figure 34-20 shows the final page.

Available Inventory

+ Create a new Car

Vehicle List

| Make | Color | Pet Name | |
|-------|--------|----------|---|
| VW | Black | Zippy | Edit Details Delete |
| Ford | Rust | Rusty | Edit Details Delete |
| Saab | Black | Mel | Edit Details Delete |
| Yugo | Yellow | Clunker | Edit Details Delete |
| BMW | Black | Bimmer | Edit Details Delete |
| BMW | Green | Hank | Edit Details Delete |
| BMW | Pink | Pinky | Edit Details Delete |
| Pinto | Black | Pete | Edit Details Delete |
| Foo | Bar | FooBar | Edit Details Delete |

Figure 34-20. The final Index view

The Details View

There aren't a lot of changes to be made to the `Details.cshtml` view. Just like the `Index.cshtml` view, the `Details.cshtml` view uses the `DisplayNameFor()` and `DisplayFor()` HTML helpers. Since you updated the `AutoLotDAL`, the "Pet Name" change carried through to this view as well. So, the only thing you need to do on this page is delete the `TimeStamp` rows.

Updating the View with Bootstrap

Start by deleting the `<h2>Details</h2>` and `<h4>Inventory</h4>` lines and replace them at the top with the following:

```
<div class="well well-sm"><h1>Inventory Details</h1></div>
```

Next, update the Edit and Back To List links to use the GlyphIcons and add a Delete link. The updated markup is listed here, and the updated page is shown in Figure 34-21:

```
<a href="@Url.Action("Edit", new {id = Model.CarId})">
  <span class="glyphicon glyphicon-edit"></span>&nbsp;Edit
</a>
&nbsp;|&nbsp;
<a href="@Url.Action("Delete", new {id = Model.CarId})">
  <span class="glyphicon glyphicon-trash"></span>&nbsp;Delete
</a>
&nbsp;|&nbsp;
<a href="@Url.Action("Index", new {id = Model.CarId})">
  <span class="glyphicon glyphicon-list"></span>&nbsp;Back to List
</a>
```

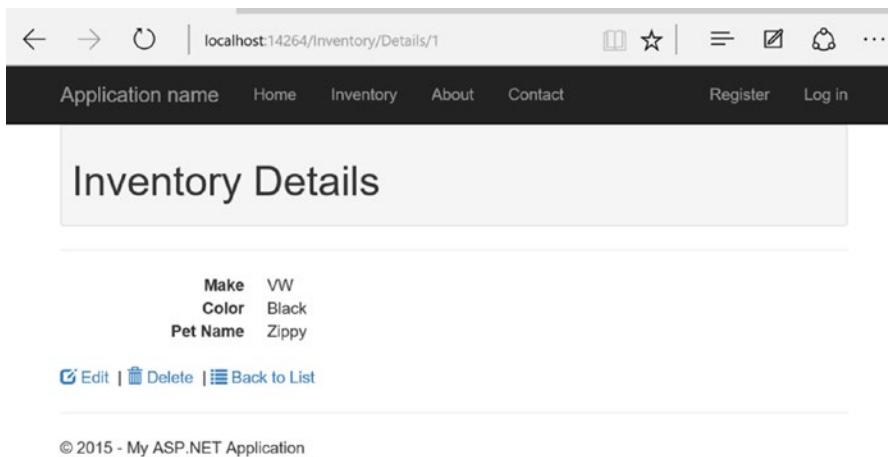

Figure 34-21. The updated details view

The Create View

Examining the code in this view, you see two more HTML helpers in use: `Html.LabelFor()` and `Html.EditorFor()`. The `EditorFor()` HTML helper creates an input field based on the data type of the property referenced in the lambda. For example, the following line:

```
@Html.EditorFor(model => model.Make, new { htmlAttributes = new { @class = "form-control" } })
```

creates this:

```
<input name="Make" class="form-control text-box single-line" id="Make" type="text" value=""
data-val-length-max="50" data-val-length="The field Make must be a string with a maximum
length of 50." data-val="true">
```

Let's examine this before moving on. The name and the id of the HTML element comes from the name of the property, the type comes from the data type of the property, and the class assignment comes from a combination of the HTML helper and the additional HTML attributes added through the helper. The value of the control is set to the property's value. In this case, the value is set to the empty string since it's a new instance of Inventory.

The `LabelFor` helper creates a `Label` control. For example, examine the following line:

```
@Html.LabelFor(model => model.Make, htmlAttributes: new { @class = "control-label col-md-2" })
```

This creates the following markup, including the `for` attribute that is automatically added (using the name of the property):

```
<label class="control-label col-md-2" for="Make">Make</label>
```

The BeginForm() HTML Helper

The `BeginForm()` HTML helper creates a `<form>` tag in the HTML output. By default, the form's action property is the current URL, and the form's method property is `post` (each is customizable through different overloads of the `BeginForm()` method). The `using` block in Razor will encapsulate everything between the opening and closing braces in between the opening and closing HTML tags. For example, if you entered this Razor block into a view:

```
@using (Html.BeginForm())
{
    <input name="foo" id="foo" type="text"/>
}
```

It would create a form tag in HTML with the action set to the same URL as the URL that brought your user to this view. For example, if the URL for the `HttpGet` request was `Inventory/Create`, the `Html.BeginForm()` helper would create the following markup:

```
<form action="/Inventory/Create" method="post">
    <input name="foo" id="foo" type="text"/>
</form>
```

The AntiForgeryToken

If you recall, the `[ValidateAntiForgeryToken]` attribute is added to all of the `HttpPost` versions of the action methods. This attribute checks for an antiforgery token submitted as part of the form values, so you need to add an antiforgery token into the `BeginForm()` Razor code block. The HTML helper to do this is aptly named `AntiForgeryToken()`, and it's already added into the scaffolded forms that require it. If you need to add it yourself to a form block, the syntax is simple.

```
@Html.AntiForgeryToken()
```

Updating the View with Bootstrap

Finalize your changes to `Create.cshtml` by deleting the `<h2>Create</h2>` and `<h4>Inventory</h4>` lines, and replace them at the top with the following:

```
<div class="well well-sm"><h1>Add Inventory</h1></div>
```

Next, update `Create` button to include the plus icon, like this:

```
<button type="submit" class="btn btn-default">
  <span class="glyphicon glyphicon-plus"></span>&nbsp;&nbsp;Create
</button>
```

The final change is to move the `Back To List` link next to the `Create` button (instead of in a lower `<div>` as created by the scaffolding) and to use the list `Glyphicon`. The updated markup is shown here:

```
&nbsp;&nbsp;&nbsp;|&nbsp;&nbsp;&nbsp;
<a href="@Url.Action("Index")">
  <span class="glyphicon glyphicon-list"></span>&nbsp;&nbsp;Back to list
</a>
```

The complete markup for the `<div>` section looks like this:

```
<div class="form-group">
  <div class="col-md-offset-2 col-md-10">
    <button type="submit" class="btn btn-default">
      <span class="glyphicon glyphicon-plus"></span>&nbsp;&nbsp;Create
    </button>
    &nbsp;&nbsp;&nbsp;|&nbsp;&nbsp;&nbsp;
    <a href="@Url.Action("Index")"><span class="glyphicon glyphicon-list">
    </span>&nbsp;&nbsp;Back to list</a>
  </div>
</div>
```

Figure 34-22 shows the final look for the view.

Figure 34-22. The Add Inventory view

The Delete View

The scaffolded Delete view displays the Timestamp field, which is meaningless (and potentially confusing) to the user. Delete the `<dt>` and `<dd>` tags for the Timestamp field (you will add the Timestamp field back in as a hidden value next).

Hidden Values

In addition to the CarId value, the `Delete()/DeleteAsync()` methods on the `InventoryRepo` object require the Timestamp value to be sent with the CarId, or an `Inventory` object with the CarId and TimeStamp fields populated. The URL is set up to send the CarId (e.g., `/Inventory/Delete/46`), but the best way to send these values is through form values in the HTTP request body and not as query string values in the URL.

To do this, you will use another HTML helper inside the `BeginForm()` Razor block: the `HiddenFor()` helper. This creates a hidden form value for the property referred to in the lambda. Add in the hidden form values (within the `BeginForm()` Razor block), like this:

```
@Html.HiddenFor(x => x.CarId)
@Html.HiddenFor(x => x.Timestamp)
```

This creates the following HTML:

```
<input name="CarId" id="CarId" type="hidden" value="46" data-val-required="The CarId field
is required." data-val-number="The field CarId must be a number." data-val="true">
<input name="Timestamp" id="Timestamp" type="hidden" value="AAAAAABAdE">
```

Validation Summary

Even though I haven't covered validation yet, add another HTML helper, `ValidationSummary()`, inside the `BeginForm()` Razor block.

```
@Html.ValidationSummary(true, "", new { @class = "text-danger" })
```

Updating the View with Bootstrap

Start by deleting the `<h2>Delete</h2>` and `<h4>Inventory</h4>` lines and replacing them at the top with the following:

```
<div class="well well-sm"><h1>Delete</h1></div>
```

Next, update the Delete button to include the Trash icon, like this:

```
<button type="submit" class="btn btn-default">
  <span class="glyphicon glyphicon-trash"></span>&nbsp;Delete
</button>
```

The final change is to update the Back To List link to use the list `Glyphicon`. The updated markup is shown here:

```
&nbsp;|&nbsp;
<a href="@Url.Action("Index")">
  <span class="glyphicon glyphicon-list"></span>&nbsp;Back to list
</a>
```

The complete markup for the `<div>` section looks like this:

```
<div class="form-actions no-color">
  <button type="submit" class="btn btn-default">
    <span class="glyphicon glyphicon-trash"></span>&nbsp;Delete
  </button>
  &nbsp;|&nbsp;
  <a href="@Url.Action("Index")"><span class="glyphicon glyphicon-list">
    </span>&nbsp;Back to list</a>
</div>
```

Figure 34-23 shows the updated view.

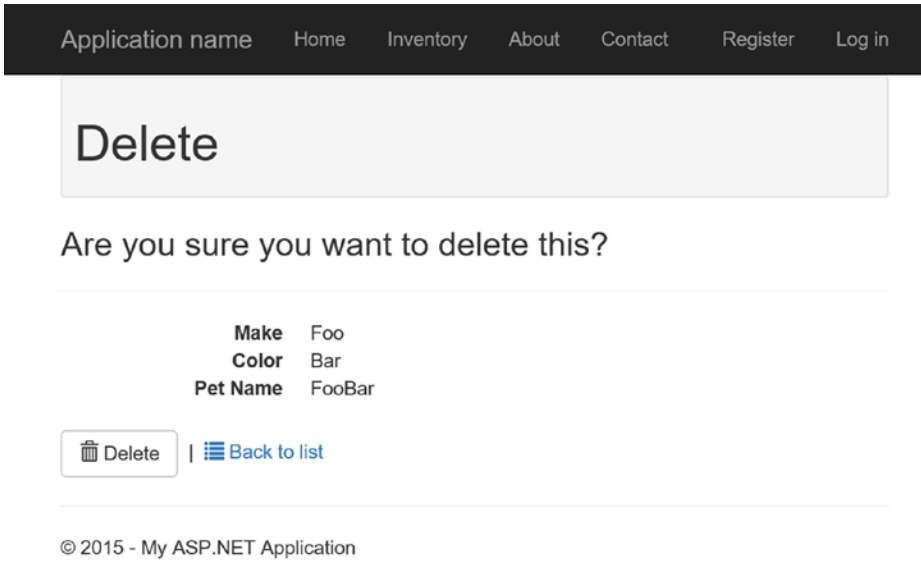

Figure 34-23. The updated Delete view

The Edit View

The scaffolded `Edit.shtml` view displays the `Timestamp` field, which is meaningless (and potentially confusing) to the user. Delete the `<div class="form-group">` for the `Timestamp` field, and add a `HiddenFor()` immediately after the `HiddenFor(model=>model.CarId)` line like this:

```
@Html.HiddenFor(model => model.Timestamp)
```

Updating the View with Bootstrap

Start by deleting the `<h2>Edit</h2>` and `<h4>Inventory</h4>` lines and replace them at the top with the following:

```
<div class="well well-sm"><h1>Edit</h1></div>
```

Next, update the Save button to include the Save icon, like this:

```
<button type="submit" class="btn btn-default">
  <span class="glyphicon glyphicon-save"></span>&nbsp;&nbsp;&nbsp;Save
</button>
```

Validation

MVC applications have two layers of validation: server side and client side. You saw server-side validation earlier in the chapter, when you added errors to the `ModelState`, in addition to the errors that came from model binding failures (because of datatype conversion, data annotation failures, or some other reason). Client-side checking happens with JavaScript, and you'll look at that soon enough.

Displaying Errors

The `ModelState` errors get displayed in the UI by the HTML helpers `ValidationMessageFor()` and `ValidationSummary()`. The `ValidationSummary()` will show `ModelState` errors that are not attached to a property as well as property errors (as long as the `ExcludePropertyErrors` is set to `false`). Typically, you will display property errors alongside the properties and show only non-property-specific errors in the `ValidationSummary()`. For example, the following line (in the `Create`, `Update`, and `Delete` views) will show all the model errors and none of the property errors in a red font:

```
@Html.ValidationSummary(true, "", new { @class = "text-danger" })
```

To show individual property errors, use the `ValidationMessageFor()` helper adjacent to a particular property in the view page, like this:

```
@Html.ValidationMessageFor(model => model.Make, "", new { @class = "text-danger" })
```

This produces the following markup:

```
<span class="field-validation-valid text-danger" data-valmsg-replace="true" data-valmsg-for="Make"></span>
```

To see this in action, you first have to disable client-side validation, which was added to the page as part of the default scaffolding. To do this, open `Create.cshtml` and comment out the rendering of the jQuery validation bundle at the end of the code.

```
@section Scripts {
    @Scripts.Render("~/bundles/jqueryval")
}
```

Next, open `InventoryController.cs` and update the first part of the `Create` `HttpPost` action method to the following:

```
if (!ModelState.IsValid)
{
    ModelState.AddModelError(string.Empty,
        "An error occurred in the data. Please check all values and try again.");
    return View(inventory);
}
```

Now run the project, navigate to the `Inventory ► Create` page, and type something into the `Make` field that is longer than 50 characters. When you click `Save`, the form values are posted back to the `Create` method. The model is validated during model binding and fails since the `Make` property has the `[StringLength(50)]` attribute. The result should look something like [Figure 34-25](#).

Add Inventory

- An error occurred in the data. Please check all values and try again.

Make

The field Make must be a string with a maximum length of 50.

Color

Pet Name

Figure 34-25. Displaying server-side validation

Client-Side Validation

Client-side validation is handled through the jQuery (jquery-2.1.4.min.js), jQuery validation (jquery.validate.min.js), and jQuery validation unobtrusive (jquery.validate.unobtrusive.min.js) libraries. The jQuery validation libraries add HTML5 data attributes used for the validation of user input. The MVC framework works with jQuery by examining the attributes on the model to determine which validations to add. The results are then generated by the `EditorFor` HTML helper into the following markup for the `Make` property:

```
<input name="Make" class="form-control text-box single-line input-validation-error" id="Make"
aria-invalid="true" aria-describedby="Make-error" type="text" value="" data-val-length-max="50"
data-val-length="The field Make must be a string with a maximum length of 50." data-val="true">
```

The data attributes also support custom error messages. Open the `Inventory.cs` class in the `AutoLotDAL` project, and update the `StringLength` attribute on the `Make` property to include an `ErrorMessage` assignment, like this:

```
[StringLength(50,ErrorMessage="Please enter a value less than 50 characters long.")]
public string Make { get; set; }
```

Now run the app, repeat the test, and the error message displays like [Figure 34-26](#).

Add Inventory

- An error occurred in the data. Please check all values and try again.

Make

Please enter a value less than 50 characters long.

Color

Pet Name

| [☰ Back to list](#)

Figure 34-26. Updated error message from the data annotations

Finishing the UI

You're going to finish off the MVC section of this chapter by cleaning up the remaining items on the UI.

Updating the Layout View

Start by opening `_Layout.cshtml` under `Views/Shared`. At the top of the page, add a Razor code block to declare a string variable and assign the value of `Car Lot MVC`. This is to replace all the hard-coded instances of the application name. The code is listed here:

```
@{
    var appName = "Car Lot MVC";
}
```

Next, replace the hard-coded strings "My ASP.NET Application" and "Application Name" with `@appName`. You will find three places to make the change in the `<title>` HTML tag, in the nav-bar `ActionLink()` helper, and in the footer. The updated code is shown here:

```
<!-- In the <head> section -->
<title>@ViewBag.Title - @appName</title>
<head>
    <title>@ViewBag.Title - @appName</title>
    <!-- rest omitted for brevity -->
</head>
```



```

<!-- In the nav-bar header <div> -->
<div class="navbar navbar-inverse navbar-fixed-top">
  <div class="container">
    <div class="navbar-header">
      <button type="button" class="navbar-toggle" data-toggle="collapse"
        data-target=".navbar-collapse">
        <!-- omitted for brevity -->
      </button>
      @Html.ActionLink(@appName, "Index", "Home", new { area = "" }, new { @class = "navbar-brand" })
    </div>
    <!-- omitted for brevity -->
  </div>
</div>

<!-- In the <footer> section -->
<footer>
  <p>&copy; @DateTime.Now.Year - @appName</p>
</footer>

```

For the final change, place the image of the slug bug in the menu bar. This probably isn't where you want to place an advertisement in a real web site; however, this example shows that you can place anything in the menu bar, and when the viewport size changes, the responsive features of Bootstrap hide those items. Create a folder named `Images` under the `Content` folder in `CarLotMVC`. Next, add an image to the folder; you can find the example image in the Chapter 34 downloads. Now add the image to the navigation bar, just before the call to load the `_LoginPartial` partial view.

```

@Html.Partial("_LoginPartial")

```

When you run the app, you'll see the image in the menu bar, as in Figure 34-27. When you shrink the viewport of your browser, you'll see that the image disappears along with the menus.



Figure 34-27. Adding an image to the menu bar

Update the Home Page

The final change is to update the home page, which is (as you already know) the `Index` view of the `Home` controller. Start by updating the `JumboTron` to the following:

```

<div class="jumbotron">
  <h1>Car Lot MVC</h1>
  <p class="lead">A site for viewing and updating vehicles in the dealership.</p>
</div>

```

Next, delete all the content after the JumboTron block, and add the following:

```
<h2>View the Inventory</h2>
<p>
  Autolot has the car you are looking for! Check out our expansive inventory on the
  @Html.ActionLink("Inventory", "Index", "Inventory") page.
</p>
```

Figure 34-28 shows the final result.

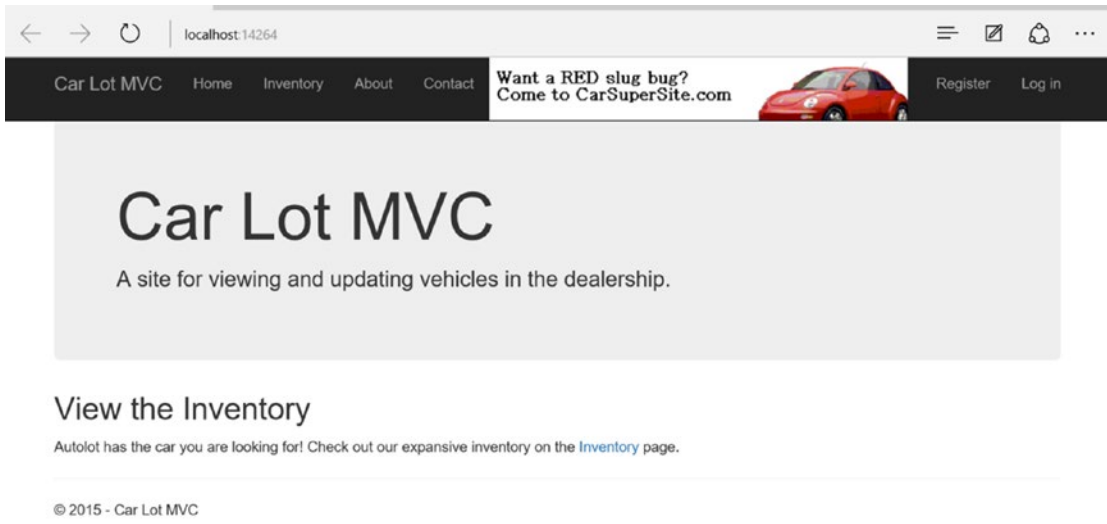

Figure 34-28. Final version of the home page

The Final Word on ASP.NET MVC

The question I am often asked is this: “Web Forms or MVC?” The answer is not that simple. If your dev team is more comfortable with the drag-and-drop nature of UI creation or they struggle with the stateless nature of HTTP, Web Forms is probably the better choice. If your team is more comfortable with having complete control of the UI (which also means less “magic” being done for you) and developing stateless applications that leverage the HTTP verbs (such as `HttpGet` and `HttpPost`), then MVC is probably a better choice. Of course, there are a lot more factors to consider in your decision. These are just a few of them.

The good news is that you don’t have to choose between MVC and Web Forms. As mentioned at the beginning of this chapter, both are based on `System.Web` (up to and including MVC5), and they have always been able to be used together. When Microsoft introduced One ASP.NET in Visual Studio 2013, blending the two frameworks into a single project became much easier.

Admittedly, this chapter only scratches the surface of ASP.NET MVC. There is just too much to cover in one chapter. For a deeper look into all that MVC has to offer, *Pro ASP.NET MVC 5* by Adam Freeman (available on Apress at www.apress.com/9781430265290?gtmf=s) is an excellent book on the subject.

■ **Source Code** The CarLotMVC solution can be found in the Chapter 34 subfolder.

Introducing ASP.NET Web API

As you learned in Chapter 25, Windows Communication Foundation (WCF) is a full-fledged framework for creating .NET-based services that can communicate with a wide range of clients. While WCF is extremely powerful, if all you need are simple HTTP-based services, creating WCF-based services may be more involved than you want or need. Enter ASP.NET Web API, another framework for building web APIs in .NET that can be accessed from any HTTP-aware client. As an MVC developer, Web API is a logical addition to your .NET toolbox. Web API is built on MVC and leverages many of the same concepts such as models, controllers, and routing. Web API was first released with Visual Studio 2012 as part of MVC 4 and updated to version 2.2 with Visual Studio 2013 Update 1.

Adding the Web API Project

Start by adding a Web API project to your solution. Right-click your solution, select Add ► New Project, and select ASP.NET Web Application (shown in Figure 34-29). Name the project CarLotWebAPI.

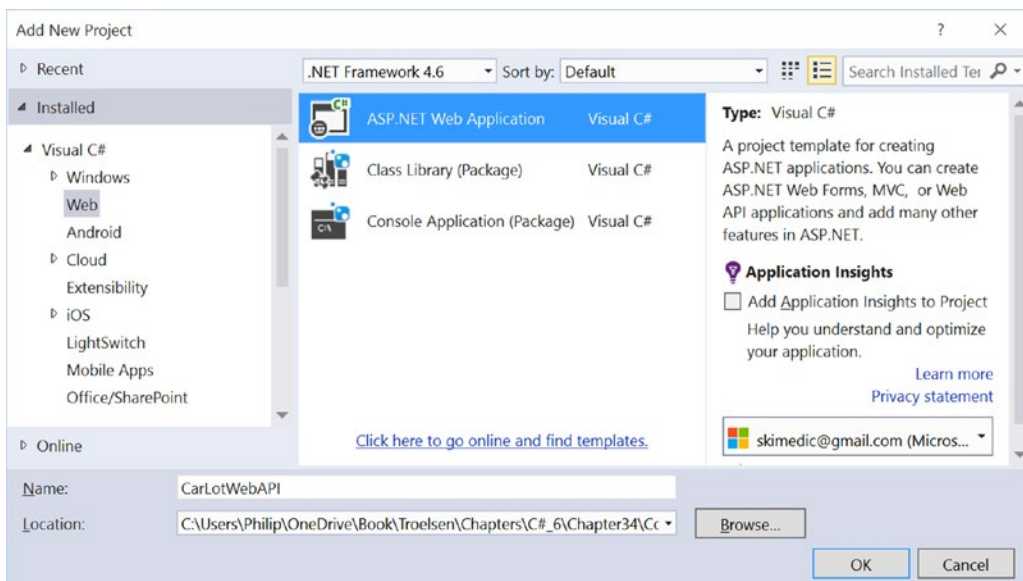

Figure 34-29. Adding a new ASP.NET web application

By now you should be familiar with the next screen. This time, select the Empty template and check the “Add folders and core references for:” Web API (as shown in Figure 34-30). If you select the Web API template, a lot of boilerplate and sample code (including MVC controllers and views) is added to the project, and all you need is the base Web API plumbing. The next screen presents the same choices you saw when creating a Web Forms or MVC app, and the options are collectively referred to as One ASP.NET.

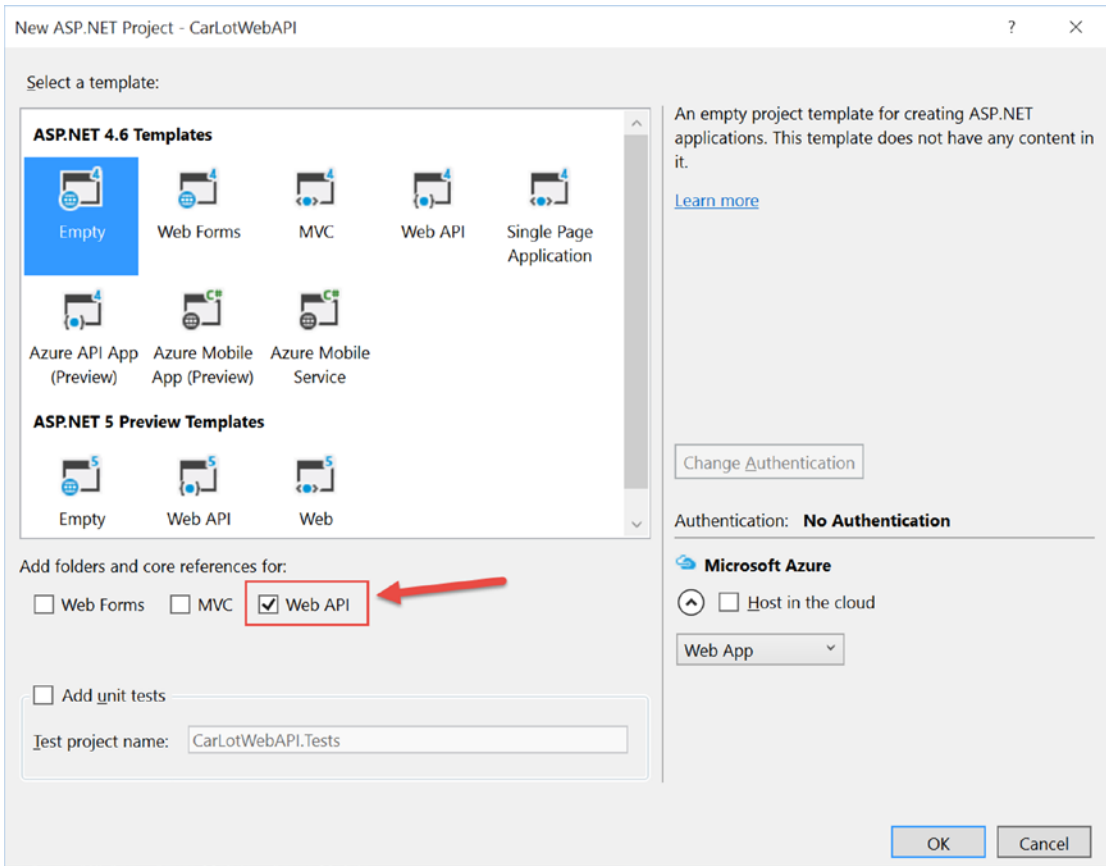

Figure 34-30. Adding the Empty project template with Web API support

Click OK, and the project is added to the solution. As with the Web Forms and MVC projects, many of the included NuGet packages are out-of-date when you create a new project. Right-click the project in Solution Explorer, select Manage NuGet Packages, and change the filter to Upgrade Available. Upgrade all the packages that can be upgraded. Change the filter back to All and install Entity Framework (as you have done previously). You need to install one additional package: AutoMapper (which you will use later in the chapter). To find this package, enter **AutoMapper** in the search box (as in Figure 34-31).

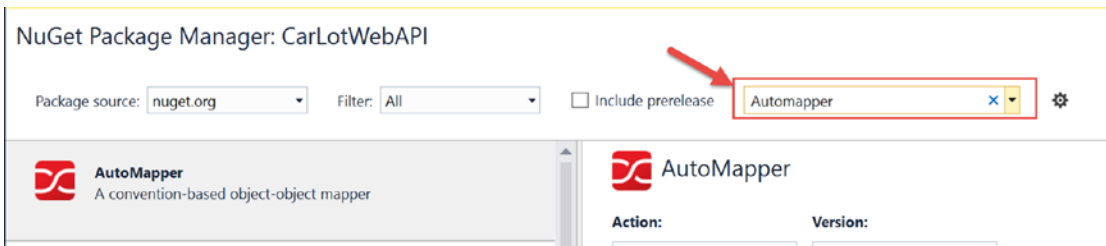

Figure 34-31. Installing AutoMapper from NuGet

Finally, add a reference to the AutoLotDAL project (by right-clicking the References node in Solution Explorer for CarLotWebAPI and selecting AutoLotDAL from Projects/Solution). Add the connection string to the Web.config file (your connection string may differ based on your installation path).

```
<connectionStrings>
  <add name="AutoLotConnection" connectionString="data source=localhost\
  SQLEXPRESS2014;initial catalog=AutoLot;integrated security=True;MultipleActive
  ResultSets=True;App=EntityFramework" providerName="System.Data.SqlClient" />
</connectionStrings>
```

Examining the Web API Project

This project is a lot more barren than the MVC project you created at the beginning of this chapter. Let's examine the files that were created. Start by opening the WebApiConfig.cs file in the App_Start folder. The code (listed next) should look familiar to you. The first line enables attribute routing (not covered in this book). The second line defines the default route with the default values. The default route is a little different from what you saw in MVC. The first major difference is the lack of an action in the route. This is because (as you will see later in this chapter) routing beyond the controller is based on the HTTP verb used in the request. Finally, the id is set to RouteParameter.Optional, just like MVC.

```
public static void Register(HttpConfiguration config)
{
  // Web API configuration and services

  // Web API routes
  config.MapHttpAttributeRoutes();

  config.Routes.MapHttpRoute(
    name: "DefaultApi",
    routeTemplate: "api/{controller}/{id}",
    defaults: new { id = RouteParameter.Optional }
  );
}
```

Next, open the Global.asax.cs file (listed next). This is a stripped-down version of what you saw in MVC. There is only one line in the file, and it adds the routing for the web route(s).

```
protected void Application_Start()
{
  GlobalConfiguration.Configure(WebApiConfig.Register);
}
```

Configuring the Project

Since the CarLotWebAPI project is a headless service (i.e., without any UI), it needs to be configured to run on start and wait for a call to one of the configured routes. To do this, open the project properties by right-clicking the project name in Solution Explorer and selecting Properties. Click the Web item in the left sidebar and then select "Don't open a page. Wait for a request from an external application." Also, make note of the project URL (in my example, it's http://localhost:46024/). This is shown in Figure 34-32.

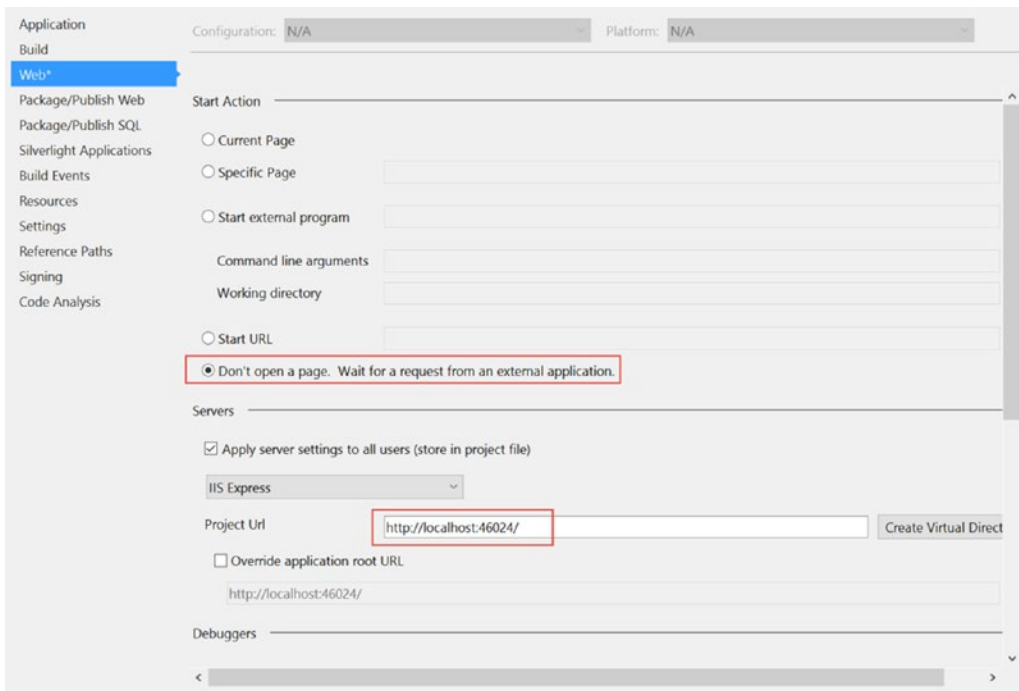

Figure 34-32. Configuring the project startup for CarLotWebAPI

Finally, set CarLotWebAPI as the startup project in your solution by right-clicking the project name in Solution Explorer and clicking Set as StartUp Project.

A Note About JSON

JavaScript Object Notation (JSON) is one way to transport data between services. It is a simple key-value text representation of objects and classes. For example, consider the following JSON representation of an Inventory item:

```
{"CarId":1,"Make":"VW","Color":"Black","PetName":"Zippy","Timestamp":"AAAAAAAAB9o=","Orders":[]}
```

Each JSON object starts and ends with braces, and property name and string values are quoted. JSON objects can also be nested. If the Make property wasn't a string but an object (with the properties Builder and Year), the JSON could resemble something like this:

```
{"CarId":1,"Make":{"Builder":"VW","Year":2015},"Color":"Black","PetName":"Zippy","Timestamp":"AAAAAAAAB9o=","Orders":[]}
```

As you can see from the Orders property, lists are indicated by brackets ([]). If the service was sending a list of Inventory objects, the JSON might resemble this:

```
[{"CarId":1,"Make":"VW","Color":"Black","PetName":"Zippy","Timestamp":"AAAAAAAAB9o=","Orders":[]},{ "CarId":2,"Make":"Ford","Color":"Rust","PetName":"Rusty","Timestamp":"AAAAAAAAB9s=","Orders":[]}]
```

■ **Note** The Web API project template includes a free open source utility called JSON.NET. It is a robust utility for creating JSON from objects, as well as creating objects from JSON. You will use JSON.NET later in this chapter, and you can find more information (including documentation and examples) at www.newtonsoft.com/json.

Adding a Controller

Just like MVC, Web API code is centered on controllers and actions. Right-click the Controllers folder and select Add ► Controller. Next, select Web API 2 Controller with actions, using Entity Framework (shown in Figure 34-33), and click Add.

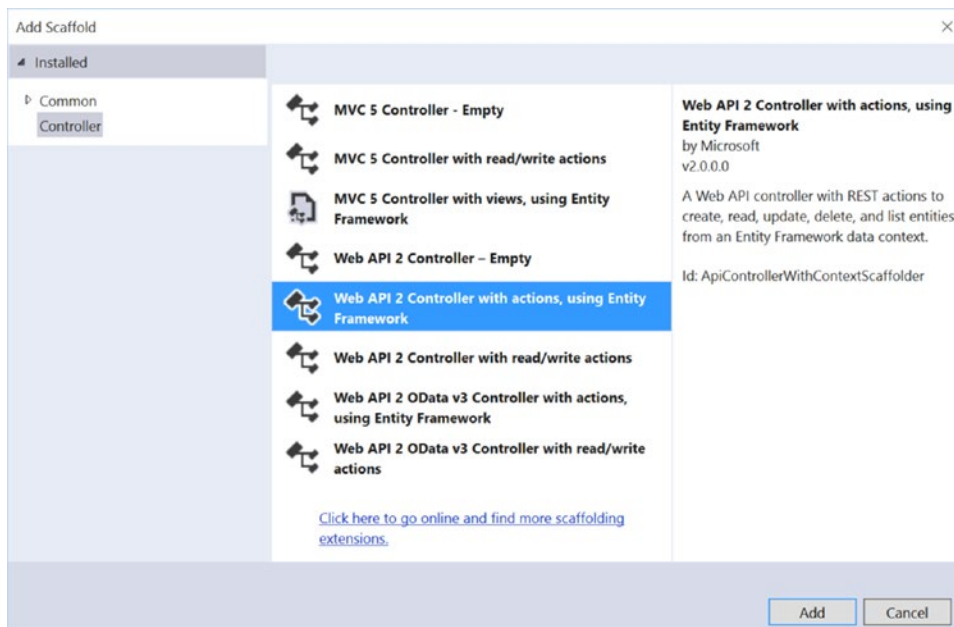

Figure 34-33. Adding a new Web API 2 Controller

On the Add Controller screen, select the Inventory class for the model and select AutoLotEntities for the data context. Check the box that asks to use async controller actions, change the name to InventoryController (shown in Figure 34-34), and click Add.

Figure 34-34. Adding the Model and Context classes for the controller

Examining the Controller Methods

Open the newly created `InventoryController.cs` class, add a class-level variable for the `InventoryRepo` class, and instantiate it. Also, dispose of the repo in the controller `Dispose()` method. Both code snippets are listed here:

```
private readonly InventoryRepo _repo = new InventoryRepo();
protected override void Dispose(bool disposing)
{
    if (disposing)
    {
        db.Dispose();
        _repo.Dispose();
    }
    base.Dispose(disposing);
}
```

Next, look at the action method signatures. While they resemble the actions from the MVC `InventoryController.cs` class, there are some glaring differences. Instead of routing the request based on the content of the URL, many of the actions take the same URL! Recall that in MVC, there are two methods each for `Add()`, `Update()`, and `Delete()` actions, and MVC decides which one to use based on the HTTP verb in the request (either `HttpGet` or `HttpPost`). Web API follows the same pattern but uses additional HTTP verbs to distinguish between calls. In addition to the `HttpGet` and `HttpPost` verbs used in MVC, Web API also uses `HttpPut` and `HttpDelete`. Another glaring difference is the lack of HTTP verb attributes decorating the actions! This is more convention over configuration. Web API looks for the case-insensitive match of the start of the action name with the HTTP verb. For example, an action named `DeleteInventory()` would handle the `HttpDelete` request. You can certainly call the method anything you want, but then you would have to remember to decorate the method with the correct attribute. In the next sections, you will examine the actions in more detail as you update them to use the `InventoryRepo` from the `AutoLotDAL` library.

Getting All Inventory Records

There are two `HttpGet` methods, `GetInventory()` and `GetInventory(int id)`. The first gets all the inventory records (recall that the `id` parameter is optional in the route). It's a pretty standard method just like what you saw in your MVC controller, except that this action method doesn't return an `ActionResult`; it appears to just return data. In actuality, in addition to the data, the Web API framework wraps the data in an `HttpOk(200) HttpResponseMessage`, adding the data as the message body. The only change to this method is to update the `InventoryRepo.GetAll()` method and change the return type to `IEnumerable<Inventory>`, as follows:

```
// GET: api/Inventory
public IEnumerable<Inventory> GetInventory()
{
    return _repo.GetAll();
}
```

Now it's time to test the app. When you run the solution, it appears that nothing happened except the Run icon in Visual Studio changed to the traditional Pause/Stop icon. This is because you set the project to run headless and just wait for an external call. When everything is loaded (and the debug icons have changed), open a new web browser. Enter the URL for the service (you saw this when you changed the project web properties), plus the route, which is `api/Inventory`. On my machine, this equates to this (your port number will most likely be different):

```
http://localhost:46024/api/Inventory
```

When you enter this into the browser, you will get the following error as plain text (actually the error is much longer, but it's shortened here to show the key part of the message). There isn't any "yellow screen of death" like you are used to seeing in Web Forms and MVC!

```
"Message": "An error has occurred.", "ExceptionMessage": "Self referencing loop detected for property 'Car' with type 'System.Data.Entity.DynamicProxies.Inventory_4F2216023579E149E169D586253289F35987B42694292AD3BF08836508A419F5'. Path '[0].Orders[0]'"
```

The lack of the traditional error page that you get in MVC (or Web Forms) is because Web API returns everything as JSON, unless specified otherwise. Therefore, the calling application (in this case the browser) doesn't know an error occurred; it just displays the returned text. Note that Web API can also return any of the standard HTTP error codes (as you will see later). When Web API returns an error, the calling application is responsible for interpreting it and handling it accordingly. To see this, open the developer tools for your browser (F12 for most browsers), navigate to the Network tab, and then refresh your browser. The developer tools will show you great details about the call, the returned `HttpMessage`, and any errors (shown in Figure 34-35).

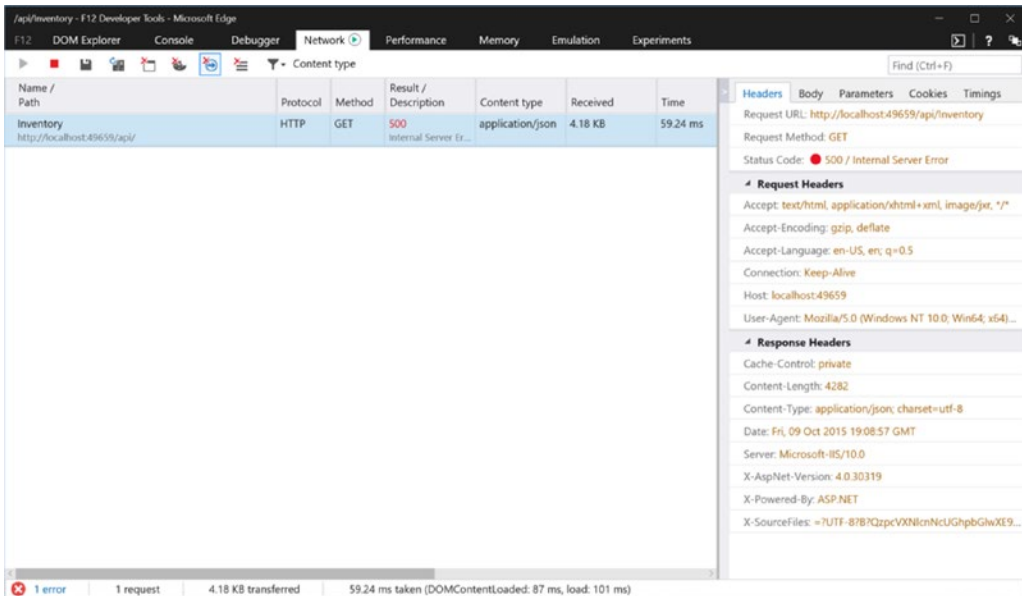

Figure 34-35. Showing HTTP errors in Microsoft Edge browser

The error itself is because EF (by default) lazy loads entities. If you recall from Chapter 23, lazy loading means that EF will call for the data from the database when properties are requested. Serialization of .NET objects traverses every property, so in this case, it walks down the list of Orders, and the Order class has a reference back to its Inventory class. This circular reference causes the serialization to fail. To resolve this, you either need to turn lazy loading off or copy all the relevant properties into a new class, ignoring the ones that cause problems for serialization. You will do that next with AutoMapper.

Creating View Models with AutoMapper

AutoMapper (which you installed earlier in this section) is a free, open source utility for creating a new instance of a type from an instance of another type. It can also be used to create a new instance of the same type, which you will do here. Add a new constructor into `InventoryController.cs`, and in that constructor add the following code:

```
public InventoryController()
{
    Mapper.Initialize(
        cfg =>
        {
            cfg.CreateMap<Inventory, Inventory>()
                .ForMember(x => x.Orders, opt => opt.Ignore());
        });
}
```

This code creates a mapping between the `Inventory` type and itself, ignoring the `Orders` property. AutoMapper uses reflection to determine what properties match between the two types and will copy all the values from the original instance into a new instance of the target type, with the exception of any ignored properties (in this example, the `Orders` navigation property). It also works on collections, as you will see next.

Next, update the `Inventory()` method to convert the list of `Inventory` records into a new list of `Inventory` records that don't contain any `Orders`, like this:

```
// GET: api/Inventory
public IEnumerable<Inventory> GetInventory()
{
    var inventories = _repo.GetAll();
    return Mapper.Map<List<Inventory>, List<Inventory>>(inventories);
}
```

■ **Note** There isn't enough space in this chapter to go any deeper with `AutoMapper`, but it is an active and widely used utility for .NET developers. You should consider adding it to your standard toolbox. You can find more information, including documentation and examples, at the project home page at <http://automapper.org>.

Run the app again and, using Internet Explorer or Microsoft Edge (both Chrome and Firefox return XML by default), enter the `Inventory` URI (<http://localhost:46024/api/Inventory>). You will see the following JSON output (your actual data might vary):

```
[{"CarId":1,"Make":"VW","Color":"Black","PetName":"Zippy","Timestamp":"AAAAAAAAB9o=","Orders":[]}, {"CarId":2,"Make":"Ford","Color":"Rust","PetName":"Rusty","Timestamp":"AAAAAAAAB9s=","Orders":[]}, {"CarId":3,"Make":"Saab","Color":"Black","PetName":"Mel","Timestamp":"AAAAAAAAB9w=","Orders":[]}, {"CarId":4,"Make":"Yugo","Color":"Yellow","PetName":"Clunker","Timestamp":"AAAAAAAAB9o=","Orders":[]}, {"CarId":5,"Make":"BMW","Color":"Black","PetName":"Bimmer","Timestamp":"AAAAAAAAB94=","Orders":[]}, {"CarId":6,"Make":"BMW","Color":"Green","PetName":"Hank","Timestamp":"AAAAAAAAB98=","Orders":[]}, {"CarId":7,"Make":"BMW","Color":"Pink","PetName":"Pinky","Timestamp":"AAAAAAAAB+A=","Orders":[]}, {"CarId":13,"Make":"Pinto","Color":"Black","PetName":"Pete","Timestamp":"AAAAAAAAB+E=","Orders":[]}, {"CarId":54,"Make":"Yugo","Color":"Brown","PetName":"Brownie","Timestamp":"AAAAAABX5E=","Orders":[]}, {"CarId":55,"Make":"Yugo","Color":"Brown","PetName":"Brownie","Timestamp":"AAAAAABbzE=","Orders":[]}, {"CarId":56,"Make":"Yugo","Color":"Brown","PetName":"Brownie","Timestamp":"AAAAAABftE=","Orders":[]}, {"CarId":57,"Make":"Yugo","Color":"Brown","PetName":"Brownie","Timestamp":"AAAAAABjnE=","Orders":[]}, {"CarId":58,"Make":"Yugo","Color":"Brown","PetName":"Brownie","Timestamp":"AAAAAABnhE=","Orders":[]}, {"CarId":59,"Make":"Yugo","Color":"Brown","PetName":"Brownie","Timestamp":"AAAAAABrbE=","Orders":[]}, {"CarId":60,"Make":"Yugo","Color":"Brown","PetName":"Brownie","Timestamp":"AAAAAABvE=","Orders":[]}, {"CarId":61,"Make":"Yugo","Color":"Brown","PetName":"Brownie","Timestamp":"AAAAAABzPE=","Orders":[]}, {"CarId":62,"Make":"Yugo","Color":"Brown","PetName":"Brownie","Timestamp":"AAAAAAB3JE=","Orders":[]}, {"CarId":63,"Make":"Yugo","Color":"Brown","PetName":"Brownie","Timestamp":"AAAAAAB7DE=","Orders":[]}, {"CarId":64,"Make":"Yugo","Color":"Brown","PetName":"Brownie","Timestamp":"AAAAAAB+9E=","Orders":[]}]
```

You see the `Orders` property is still there, but all the records are empty, avoiding the circular reference issue. Problem solved!

Getting One Inventory Record

The second `HttpGet` method, `GetInventory(int id)`, returns a single inventory record based on the ID passed in. Update the method to call the `GetOneAsync()` method from the repo, and use `AutoMapper` to create a new instance of an `Inventory` class, as follows:

```
// GET: api/Inventory/5
[ResponseType(typeof(Inventory))]
public async Task<IHttpActionResult> GetInventory(int id)
{
    Inventory inventory = await _repo.GetOneAsync(id);
    if (inventory == null)
    {
        return NotFound();
    }
    return Ok(Mapper.Map<Inventory, Inventory>(inventory));
}
```

There are four new items/methods in this action method: the `ResponseType` attribute, `IHttpActionResult`, and the `NotFound()` and `Ok()` methods. The `ResponseType` attribute is used to specify the entity type returned in the body of the `HttpResponseMessage`. In this, it's priming the pump to serialize an `Inventory` record for the `IHttpActionResult` (which is the Web API version of MVC's `ActionResult`). `NotFound()` returns a `NotFoundResult`, which translates to a 404 error message. `Ok()` returns an `HttpOk (200)` and adds the object(s) passed into the method (as JSON or XML, depending on your browser) into the message body.

To test this, enter the following into Internet Explorer/Edge (your port and `CarId` might be different):

```
http://localhost:46024/api/Inventory/5
```

Updating an Inventory Record

Updating a record in HTTP language is achieved with an `HttpPut` call and passing in the `id` of the record to be updated and an instance of the object being updated. This method uses model binding (just like Web Forms and MVC) to create an instance of the `Inventory` class with the values sent from the client in the body of the message. Update the `PutInventory()` method to use the `InventoryRepo`. The code is shown here and will be discussed after the listing:

```
// PUT: api/Inventory/5
[ResponseType(typeof(void))]
public async Task<IHttpActionResult> PutInventory(int id, Inventory inventory)
{
    if (!ModelState.IsValid)
    {
        return BadRequest(ModelState);
    }
    if (id != inventory.CarId)
    {
        return BadRequest();
    }
    try
    {
        await _repo.SaveAsync(inventory);
    }
}
```

```

catch (Exception ex)
{
    //Production app should do more here
    throw;
}
return StatusCode(HttpStatusCode.NoContent);
}

```

In the body of the action method (as with model binding in MVC and Web Forms), the first check is to make sure the `ModelState` is valid. If not, then it returns an `HttpBadRequest (400)`. If it is valid, the method then checks that the `id` passed in through the URL matches the `CarId` of the `Inventory` record (from the message body). This helps cut down (but doesn't eliminate) URL hacking by an unscrupulous user. The code then attempts to save the record and, if successful, returns an `HTTP 204 (No content)`. If there is an exception, this example merely throws it out to the client. In a production app, you would want to handle any and all exceptions accordingly.

Adding Inventory Records

Adding a record in HTTP language is achieved with an `HttpPost` call and passing the object being updated in the message body. In MVC, you used only `HttpPost` for anything other than `HttpGet` requests, but Web API is better at using the HTTP verbs correctly. The `PostInventory()` method also uses model binding to create an instance of the `Inventory` class with the values sent from the client in the body of the message. Update the method to use the `InventoryRepo`. The code is shown here and will be discussed after the listing:

```

// POST: api/Inventory
[ResponseType(typeof(Inventory))]
public async Task<IHttpActionResult> PostInventory(Inventory inventory)
{
    if (!ModelState.IsValid)
    {
        return BadRequest(ModelState);
    }
    try
    {
        await _repo.AddAsync(inventory);
    }
    catch (Exception ex)
    {
        //Production app should do more here
        throw;
    }
    return CreatedAtRoute("DefaultApi", new { id = inventory.CarId }, inventory);
}

```

The `PostInventory()` action returns the added `Inventory` record, complete with the server-generated values, so the `ResponseType` is of type `Inventory`. This action method also uses model binding to get the values from the message body, checks `ModelState`, and returns an `HttpBadRequest (400)` if there are issues in the model binding. If model binding is successful, the method then attempts to add the new record. If the add is successful, then the action returns an `HttpCreated (201)` with the new `Inventory` record in the body of the message.

Deleting Inventory Records

The final action method to update is `DeleteInventory`. The controller template creates a method that takes an `id`, pulls up the record, and, if found, deletes them. The problem with this (as you discovered with the MVC Delete action) is that the `AutoLotDAL` library uses concurrency checking to make sure no one else changed the record before this current user sent the delete request. So, you need to update the signature to accept an `id` and an `Inventory` object, which will get populated from the message body. Update the method to the following:

```
// DELETE: api/Inventory/5
[ResponseType(typeof(void))]
public async Task<IHttpActionResult> DeleteInventory(int id, Inventory inventory)
{
    if (id != inventory.CarId)
    {
        return BadRequest();
    }
    try
    {
        await _repo.DeleteAsync(inventory);
    }
    catch (Exception ex)
    {
        //Production app should do more here
        throw;
    }
    return Ok();
}
```

The first change is to update the `ResponseType` to `void`. Next, update the signature to accept an `Inventory` type in addition to the `id` parameter. In the method body, you also check to make sure the `id` parameter matches the `CarId` of the `Inventory` record from the message body. If it matches, attempt to delete the `Inventory` record. If the deletion succeeds, return an `HttpOk (200)`.

Remove the `AutoLotEntities` Variable

The final cleanup for the `InventoryController` is to remove the `AutoLotEntities` variable from the top of the class and dispose of the `repo` in the controller's `Dispose` method. The updated `Dispose` method is shown here:

```
protected override void Dispose(bool disposing)
{
    if (disposing)
    {
        _repo.Dispose();
    }
    base.Dispose(disposing);
}
```

Updating CarLotMVC to Use CarLotWebAPI

Currently, CarLotMVC uses the AutoLotDAL library for all of its CRUD operations. In this section, you will use the CarLotWebAPI for all the data access operations.

Updating the Index Action

Next, open the `InventoryController.cs` file in CarLotMVC and navigate to the `Index()` action method. Instead of using the `InventoryRepo` from the AutoLotDAL library, you are going to use the services in CarLotWebAPI. To do this, create a new `HttpClient` and call `GetAsync()`, passing in the URL of the `GetInventory()` action method. This Web API method returns an `IActionResult`. This result has two properties that you care about for this method: `IsSuccessStatusCode` and `Content`. The `IsSuccessStatusCode` returns `true` if the call worked. This prevents you from having to check every possible code that could get returned, since there are many that are considered successful. The `Content` property provides access to the message body. In the case of the `Index()` action method, if the `Inventory` records were returned, the Web API returns an `HttpOk(200)`.

If everything works, all the `Inventory` records are contained in the `Content` property as JSON. This is where `JSON.NET` comes into play (as mentioned earlier in the chapter). The `JsonConvert.DeserializeObject<T>()` method is called using either a single type (`Inventory`) or `IEnumerable` of a type (`List<Inventory>`) as the generic parameter. You then pass in the JSON string, and it attempts to convert the JSON string into the type specified. If the method successfully converts the text into objects, then it returns the `Index` view. Note that your port for the Web API call will probably be different.

```
// GET: Inventory
public async Task<ActionResult> Index()
{
    var client = new HttpClient();
    var response = await client.GetAsync("http://localhost:46024/api/Inventory");
    if (response.IsSuccessStatusCode)
    {
        var items = JsonConvert.DeserializeObject<List<Inventory>>(
            await response.Content.ReadAsStringAsync());
        return View(items);
    }
    return HttpNotFound();
}
```

■ **Note** None of these examples has the level of error handling needed for a production application. That decision was made to make sure the examples are clear and concise. You would want to take what you learned earlier in Chapter 7 to handle any and all exceptions gracefully.

Make sure the CarLotMVC app is set as the startup project by right-clicking the CarLotMVC project name in Solution Explorer. Run the app and click Set as StartUp Project. Run the app and click the `Inventory` link in the menu, and you will see the same page as when the `Index()` method was calling directly into the AutoLotDAL library. It is literally that simple!

■ **Note** You might be wondering if you still need the reference to `AutoLotDAL` in `CarLotMVC`. The answer is Yes, at least for how this solution is structured. `AutoLotDAL` contains the model definitions, and `CarLotMVC` needs access to the model classes. A common pattern (not shown here for simplicity) is to place the model definitions into a separate assembly and reference that library from any project that need the type definitions for the models.

Updating the Details Action

The next step is to update the `Details()` action method. Update the code to the following (changing your port as necessary):

```
// GET: Inventory/Details/5
public async Task<ActionResult> Details(int? id)
{
    if (id == null)
    {
        return new HttpStatusCodeResult(HttpStatusCode.BadRequest);
    }
    var client = new HttpClient();
    var response = await client.GetAsync($"http://localhost:46024/api/Inventory/{id.Value}");
    if (response.IsSuccessStatusCode)
    {
        var inventory = JsonConvert.DeserializeObject<Inventory>(
            await response.Content.ReadAsStringAsync());
        return View(inventory);
    }
    return HttpNotFound();
}
```

The main change here (just like in the `Index` action) is to change the call to get the record to `CarLotMVC` using a new `HttpClient`. Check whether the response was a successful call, and if so, use `JSON.NET` to deserialize the content of the message to an `Inventory` object. Finally, return the view.

Updating the Add Action

There are two `Create()` action methods, but the `HttpGet` version doesn't need to be updated since it loads a view without any database interaction. The `HttpPost` version does need to be updated. Fortunately, the `HttpClient` takes care of a lot of the work for you (just like in the `Index()` action method). However, before you update the method, you need to add a `using` statement for `System.Net.Http` and a reference to `System.Net.Http.Formatting`. The `System.Net.Http.Formatting` class has extension methods that you will use throughout this project, such as `PostAsJsonAsync()`, shown in the following code. The entire action method is listed here, and the changes will be discussed after the listing:

```
[HttpPost]
[ValidateAntiForgeryToken]
public async Task<ActionResult> Create([Bind(Include = "Make,Color,PetName")] Inventory inventory)
```



```

{
    if (!ModelState.IsValid)
    {
        ModelState.AddModelError(string.Empty,
            "An error occurred in the data. Please check all values and try again.");
        return View(inventory);
    }
    try
    {
        var client = new HttpClient();
        var response = await client.PostAsJsonAsync("http://localhost:46024/api/Inventory", inventory);
        if (response.IsSuccessStatusCode)
        {
            return RedirectToAction("Index");
        }
    }
    catch (Exception ex)
    {
        ModelState.AddModelError(string.Empty, $"Unable to create record: {ex.Message}");
    }
    return View(inventory);
}

```

The main change is that after creating an `HttpClient` instance, you call the `PostAsJsonAsync()` extension method. This method takes two parameters: the service URI (for example, `http://localhost/46024/api/Inventory`) and the data to post (`inventory`). The method takes care of creating the JSON for you, creating an `HttpPost` method, and inserting your data into the message body. If the request was successful, the `IsSuccessStatusCode` will be set to `true`.

Updating the Edit Action

Both of the `Edit()` action methods need to be updated. The `HttpGet` version must call `CarLotWebAPI` to get the record to display, and the changes are the same that you made to the `Details()` action method to get the data from the web service.

```

// GET: Inventory/Edit/5
public async Task

```

The `HttpPost` version uses a similar extension method as the `Add()` action method. `PutAsJsonAsync()` creates an `HttpPut` message at the specified URL and adds the objects into the body of the message as JSON. The updated code is listed here:

```
// POST: Inventory/Edit/5
[HttpPost]
[ValidateAntiForgeryToken]
public async Task<ActionResult> Edit(
    [Bind(Include = "CarId,Make,Color,PetName,Timestamp")] Inventory inventory)
{
    if (!ModelState.IsValid) { return View(inventory); }
    var client = new HttpClient();
    var response = await client.PutAsJsonAsync($"http://localhost:46024/api/Inventory/
{inventory.CarId}", inventory);
    if (response.IsSuccessStatusCode)
    {
        return RedirectToAction("Index");
    }
    return View(inventory);
}
```

■ **Note** You might be wondering why the action method in the MVC controller is marked with the `HttpPost` attribute but the call to the web service is an `HttpPut`. The important takeaway is that the HTTP verb used to call MVC actions does not have to match the HTTP verb used to call Web API action methods. They are separate operations.

Updating the Delete Action

There are two `Delete()` action methods, and like the `Edit()` `HttpGet` version, the only change is to call the web service to get the data. The change is done the same way as you did for the `Delete()` and `Details()` action methods.

```
// GET: Inventory/Delete/5
public async Task<ActionResult> Delete(int? id)
{
    if (id == null)
    {
        return new HttpStatusCodeResult(HttpStatusCode.BadRequest);
    }
    var client = new HttpClient();
    var response = await client.GetAsync($"http://localhost:46024/api/Inventory/{id.Value}");
    if (response.IsSuccessStatusCode)
    {
        var inventory = JsonConvert.DeserializeObject<Inventory>(
            await response.Content.ReadAsStringAsync());
        return View(inventory);
    }
    return new HttpNotFoundResult();
}
```

The `HttpGet Delete()` action method requires more work. As you might suspect, there is indeed a `DeleteAsync()` extension method on the `HttpClient`, but it doesn't accept any parameters for content in the message body. Using this method will cause the delete to fail since the timestamp value must be passed in as part of the concurrency check. Instead, you have to create the `HttpRequestMessage` by hand. The constructor for the `HttpRequestMessage` takes the `HttpMethod` as the first parameter and the URL as the second. Create a new instance passing in `HttpDelete` as the verb, and the URL of the `Delete()` action method, as follows:

```
HttpRequestMessage request = new HttpRequestMessage(
    HttpMethod.Delete,
    $"http://localhost:46024/api/Inventory/{inventory.CarId}");
```

Next, use `JSON.NET` to serialize the inventory object and then add it to the content. The serialization call is straightforward:

```
JsonConvert.SerializeObject(inventory)
```

When assigning content to the `HttpRequestMessage`, you have to set the encoding and the type, which is `application.json`, like this:

```
Content = new StringContent(JsonConvert.SerializeObject(inventory), Encoding.UTF8,
    "application/json")
```

Putting it all together using object initialization, you should have this:

```
HttpRequestMessage request = new HttpRequestMessage(
    HttpMethod.Delete,
    $"http://localhost:46024/api/Inventory/{inventory.CarId}")
{
    Content =
        new StringContent(JsonConvert.SerializeObject(inventory), Encoding.UTF8,
            "application/json")
};
```

Finally, send the message by calling `SendAsync()` on an instance of `HttpClient`, thus sending the request you just created. The full `Delete()` method is shown here:

```
// POST: Inventory/Delete/5
[HttpPost]
[ValidateAntiForgeryToken]
public async Task<ActionResult> Delete([Bind(Include = "CarId,Timestamp")]Inventory inventory)
{
    try
    {
        var client = new HttpClient();
        HttpRequestMessage request = new HttpRequestMessage(
            HttpMethod.Delete,
            $"http://localhost:46024/api/Inventory/{inventory.CarId}")
        {
            Content =
                new StringContent(JsonConvert.SerializeObject(inventory), Encoding.UTF8,
                    "application/json")
        };
    }
};
```

```

    var response = await client.SendAsync(request);
    return RedirectToAction("Index");
}
catch (DbUpdateConcurrencyException)
{
    ModelState.AddModelError(string.Empty, "Unable to delete record. Another user updated
the record.");
}
catch (Exception ex)
{
    ModelState.AddModelError(string.Empty, $"Unable to create record: {ex.Message}");
}
return View(inventory);
}
}

```

Testing the Applications

To run the application, you need to set both CarLotMVC and CarLotWebAPI to start when you begin debugging. Do this by right-clicking the solution in Solution Explorer and selecting Set Startup Projects. In the dialog that opens, select “Multiple startup projects” and set both CarLotMVC and CarLotWebAPI to Start (shown in Figure 34-36).

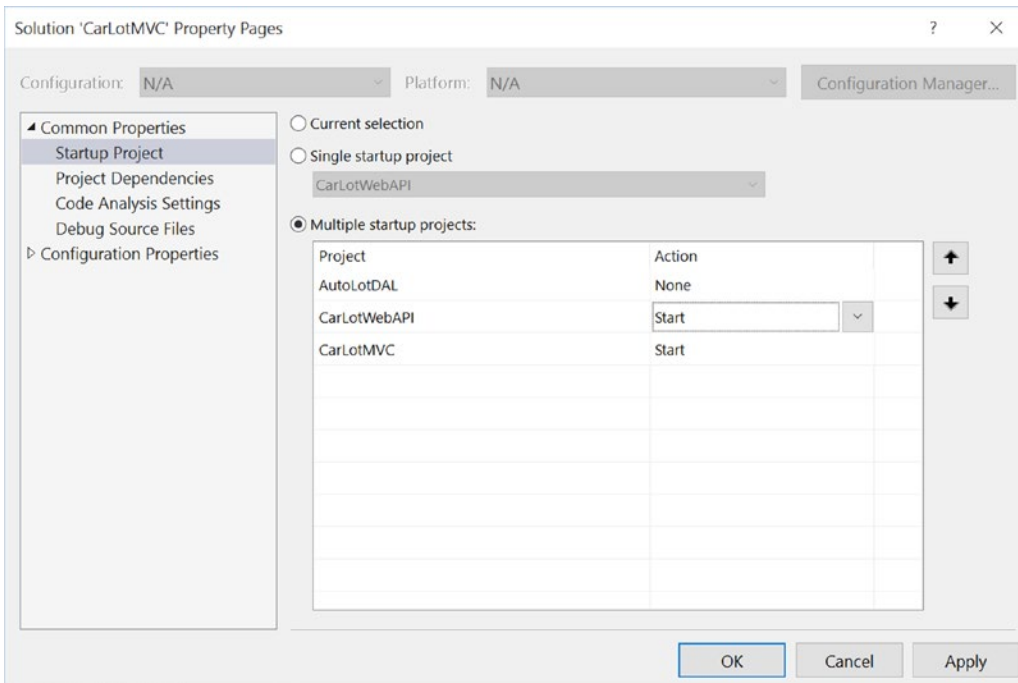

Figure 34-36. Setting multiple startup projects

Now, when you press F5 to run the solution, the CarLotMVC project will load a browser to the home page, and CarLotWebAPI will be running as a headless application, waiting for a call. Run the application, click the Inventory menu, and click around the pages. The app works the same as it did from a user perspective.

■ **Source Code** The CarLotMVC_Web API solution can be found in the Chapter 34 subfolder.

Summary

This chapter examined many aspects of ASP.NET MVC and Web API. You began by examining the Model-View-Controller pattern and then building your first MVC site. You learned about the convention over configuration for the MVC framework and about all the files scaffolded for you as part of the new project template, as well as the folders that were created and their purpose. You examined each of the classes created in the App_Start folder and how they help you create MVC applications. You also learned about bundling and minification and how to turn it off if needed.

The next section went into routing and how requests are directed to your controllers and actions. You created new routes for the About and Contact pages and learned about redirecting users to other resources in your site using routing instead of hard-coded URLs.

Next, you created a controller for the Inventory pages and learned how the scaffolding built into Visual Studio creates base action methods and views. You learned about `HttpGet` and `HttpPost` requests and how they work with routing for even finer control of what action method gets called. You then updated the action methods to use `AutoLotDAL`, as well as updating the signatures and code to fit your business requirements.

Then you learned about the Razor View Engine, the syntax, and Razor helpers, functions, and delegates. You also learned more about strongly typed views, partial views, and layouts. You also learned to send data to the view using `ViewBag`, `ViewData`, and `TempData`.

After that, you modified each scaffolded view, updated the `InventoryController` actions, added validation, and used Bootstrap to dress up the UI.

In the major next section, you learned about Web API. You created a new Web API project and examined the scaffolded files and folders and their purpose. You then used the Visual Studio scaffolding to add a controller and its action methods. You learned about additional HTTP verbs and how they are applied in Web API routing. You updated each of the action methods to use `AutoLotDAL` and Entity Framework and used `AutoMapper` to avoid the circular reference issue with EF lazy loading and serialization.

After updating all the `InventoryController` actions in `CarLotWebAPI`, you updated `CarLotMVC` to call into the `CarLotWebAPI` service's URLs, using `JSON.NET` to deserialize and serialize records. You also learned how to make calls using the additional HTTP verbs used by the Web API.

Index

■ A

- Abstract stream members, 765
- Accelerate() method, 365, 376, 383
- Activator.CreateInstance() method, 607
- Active Data Objects (ADO). *see* ADO.NET
- Adaptive rendering, 1396
- Add() method, 362
- AddAsync() method, 1554–1555
- AddComplete() method, 705–706
- add_Exploded() method, 377
- Add() method, 698, 702, 1588
- AddOne() method, 723
- AddPerson(), 401
- AddWithThreads, 745
- ADO.NET
 - AutoLot database creation
 - adding test records, 818
 - Customers and Orders tables, 820
 - GetPetName() stored procedure, 819
 - Inventory table creation, 815
 - table relationships, in Visual Studio, 822
 - connected layer of, 801
 - AutoLotDataReader, 830
 - command objects, 834
 - connection objects, 830
 - ConnectionStringBuilder objects, 833
 - data reader object, 829
 - Console UI-based front end
 - AutoLotCUIClient, 846
 - <connectionStrings> element, 847
 - DeleteCar() method, 850
 - InsertNewCar() method, 850
 - ListInventory() method, 849
 - LookUpPetName(), 851
 - Main() method implementation, 847
 - ShowInstructions() method, 849
 - statements, 846
 - UpdateCarPetName() method, 851
 - database transaction, 852
 - APIs, 853
 - Connection property, 854
 - CreditRisks tables, 854
 - DBTransaction, 853
 - IDbTransaction interface, 853
 - ProcessCreditRisk(), 855
 - Rollback(), 854
 - save points, 854
 - test, 857
 - data providers
 - application configuration files, 813
 - benefit, 802
 - C# Console Application project, 812
 - centric namespaces, 806
 - core objects, 802
 - DBMS, 803
 - factory pattern (*see* Data provider factory model)
 - IDbConnection parameter, 811
 - Microsoft, 804
 - Microsoft SQL Server, 813
 - System.Data.OracleClient.dll, 805
 - third-party, 805
 - data readers
 - DbDataReader type, 835
 - ExecuteReader(), 835
 - multiple result sets, 836
 - Read() method, 835
 - string/int, 835
 - DataSets, 800
 - DataTable, 403
 - disconnected layer, 802
 - EF, 802
 - reusable data access library
 - AutoLotDAL, 838
 - CloseConnection() method, 838
 - DbParameter type, 843
 - deletion logic, 840
 - insertion logic, 839
 - InventoryDAL.cs, 838
 - OpenConnection() method, 838
 - parameterized command
 - objects, 842
 - selection logic, 841

ADO.NET (*cont.*)

- stored procedure, 844
- update logic, 841
- System.Data namespaces
 - core members, 807
 - database primitives, 806
 - IDataReader and IDataRecord interfaces, 810
 - IDbConnection interface, 807
 - IDbDataParameter and IDataParameter interfaces, 809
 - IDbTransaction interface, 808

- System.Data.dll, 801
- Application_Error() method, 1499
- Application programming interface (API)
 - COM+, 1023
 - DCOM, 1022
 - MSMQ, 1023
 - .NET remoting, 1024
 - web service standards, 1025
 - XML web services, 1025

AsDataView<T>() extension method, 927

AsParallel() extension method, 739

AspNetCarsSite website

- AdRotator control, 1455
- AutoLotDAL assembly, 1459
- BuildCar.aspx content page, 1467
- default content page, 1456
- filtering, 1465
- GridView control, 1460
- In-Place edition and deletion, 1461
- inventory content page, 1459
- master pages, 1449
- SiteMapPath type, 1455
- sorting and paging, 1464
- TreeView control site navigation logic, 1453

ASP.NET state management

- addition custom data, 1496
- Application_End() method, 1504
- application/session state distinction, 1501
- Application_Start() method, 1502
- ASPNETDB.mdf file, 1519
- assignment data item, 1503
- btnGetCar handler, 1492
- CacheDependency object, 1507
- Cache.NoSlidingExpiration parameter, 1507
- Context.Cache property, 1505
- cookie (*see* Cookie)
- DateTime.Now.AddSeconds parameter, 1507
- Default.aspx page, 1509, 1522
- EnableViewState, 1495
- Event Handler, 1499
- GetUserAddress data, 1525
- Global.asax file, 1497
- HttpApplicationState Type, 1501
- lblUserData Label, 1523

ListItems, 1495

- Lock() method, 1504
- machine.config file, 1520
- Page_Load event handler, 1509
- Profile property, 1522
- profile data, 1521, 1524
- Remove() method, 1503
- RemoveAll() method, 1503
- Session data (*see* Session data)
- session variable, 1493
- simple web UI, 1492
- store session data, 1517
 - aspnet_state.exe, 1517
 - InstallSqlState.sql, 1518
 - session state server, 1503
 - web.config file, 1518
- System.Web.Caching.Cache class, 1505
- System.Web.HttpApplication Type, 1500
- Unlock() method, 1504
- UserAddress data, 1524
- view state, 1494
- web.config file, 1520

ASP.NET web forms

- AutoEventWireup attribute, 1430
- client-side scripting, 1395
- code-behind model
 - advantages, 1411
 - AutoLotDAL project, 1413
 - C# code file, 1413
 - CodeFile attribute, 1412
 - debugging and tracing, 1415
 - Default.aspx.cs, 1412
 - *.designer.cs file, 1413
 - example, 1412
 - GetData method, 1414
- code files, 1399
- core events, 1428
- directory structure
 - App_Code folder, 1419
 - referencing assemblies, 1419
 - subdirectories, 1418
- Error event, 1430
- features, 1398
- HTML (*see* HTML)
- HTTP (*see* HTTP)
- IIS (*see* Internet Information Services (IIS))
- life cycle, 1428
- Load event, 1428
- page type
 - inheritance chain, 1420
 - properties, 1421
- postback to web server, 1397
- single-file page model
 - application, 1403
 - *.aspx file, 1402

- AutoLotDAL directory, 1404
- control declarations, 1410
- data access logic, 1406
- directives, 1409
- script block, 1410
- templates, 1403–1404
- UI designing, 1406
- Unload event, 1429
- Web.config file, 1431
- web controls, 1399
- Web Forms 2.0, 1399
- Web Forms 3.5, 1400
- Web Forms 4.0, 1401
- Web Forms 4.5, 1401
- Web Forms 4.6, 1402
- web site *vs.* web application, 1416
- Assembly-level attribute, 585
- Asynchronous method invocation
 - Add() method, 701
 - AsyncCallback delegate, 703
 - AsyncResult Class, 706
 - AsyncState, 707
 - BeginInvoke() method, 700
 - EndInvoke() method, 700
 - IAsyncResult interface, 700
 - Main() method, 701
 - thread synchronization, 702
- Asynchronous programming
 - AddWithThreads, 745
 - C# async, 741
 - multiple awaits, 744
 - naming conventions, 743
 - void returning, 744
- Attribute-based programming
 - custom attribute
 - AssemblyInfo.cs, 586
 - assembly-level attribute, 585, 587
 - AttributeTargets enumeration, 584
 - AttributeUsage, 585
 - class definitions, 583
 - creation, 582
 - module-level attribute, 585
 - named property, 583
 - dynamic loading
 - Assembly class, 569
 - Assembly.Load() method, 571–572
 - AssemblyName type, 572
 - ExternalAssemblyReflector class, 570
 - LINQ, 573
 - extendable application
 - building process, 591
 - CommonSnappableTypes.dll, 591
 - CSharpSnapIn, 592
 - DisplayCompanyData() method, 596
 - external assemblies, 597
 - GUI, 595
 - LoadExternalModule() method, 596
 - VbSnapIn, 593
 - Windows Forms application, 593–594
- late binding
 - CreateUsingLateBinding() method, 576
 - Invoke Methods, 577
 - System.Activator class, 574
 - TurboBoost() method, 576–577
 - VehicleDescriptionAttributeReader, 587
 - VehicleDescriptionAttribute
 - ReaderLateBinding, 588
- metadata
 - Assembly token, 559
 - AssemblyRef #n token, 559
 - CarLibrary.EngineState enumeration, 556
 - get_PetName() method, 558
 - ildasm.exe, 556
 - set_PetName() method, 558
 - string literal, 560
 - TypeRef, 559
- .NET attributes
 - CLS-compliant constructs, 579
 - constructor parameter, 581
 - ildasm.exe, 580
 - notserialized token, 580
 - obsolete type, 581–582
 - predefined attributes, 578
 - serializable token, 580
 - shorthand attribute, 581
- reflection
 - GetInterfaces() method, 565
 - late binding, and custom attributes, 590
 - ListFields() method, 565
 - ListInterfaces() method, 565
 - Main() method implementation, 566
 - parameter types, 568
 - return types, 569
 - System.Collections.Generic.List, 568
 - System.Object.GetType() class, 562
 - System.Reflection.Namespace, 561
 - System.Type class, 561–562
 - System.Type.GetType() operator, 563
 - Type.GetMethods() method, 564
 - typeof() operator, 563
- Autoincrementing ability, 865
- AutoLotDAL Version 4
 - AutoLotTestDrive (see AutoLotTestDrive)
 - BaseRepo addition
 - Add() and AddRange() methods, 970
 - DbSet<T> property, 968
 - Delete()/DeleteAsync() methods, 972
 - IDisposable interface, 971
 - initial class definition, 967
 - retrieving records, 970

AutoLotDAL Version 4 (*cont.*)
 SaveChanges() helper methods, 968
 Save()/SaveAsync() methods, 972
 CreditRisk class, 963
 CreditRiskRepo, 974
 customer model class, 961
 CustomerRepo, 973–974
 data annotations, 957
 DataInitialize, 975
 DbContext addition, 964
 DropCreateDatabaseAlways class, 975
 DropCreateDatabaseAlways
 <AutoLotEntities> class, 975
 DropCreateDatabaseSelfModelChanges
 <TContext> class, 975
 inventory model class, 959
 Inventory repository, 973
 IRepo interface addition, 966
 NuGet packages, 956–957
 order model class, 961
 OrderRepo, 973
 Seed() method, 975
 AutoLot database, 932
 AutoLot database, 932
 adding test records, 818
 Customers and Orders tables, 820
 GetPetName() stored procedure, 819
 Inventory table creation, 815
 table relationships, in Visual Studio, 822
 AutoLotTestDrive
 connectionStrings updation, 976
 inventory records
 Add() or AddRange() method, 977
 editing, 978
 printing, 977
 Main() method, 977
 MakeCustomerARisk() method, 980
 navigation properties
 eager loading, 980
 output window, 979
 ShowAllOrders() method, 979
 PrintAllCustomersAndCreditRisks()
 method, 981

■ **B**

BasicStringFunctionality() method, 84
 BeginInvoke() method, 357–358, 700, 706, 726
 Binary Application Markup Language (BAML), 1116
 BinaryFormatter type, 781
 BinaryFormatter.Serialize() method, 784
 Deserialize() method, 785
 network stream, 784
 SaveAsBinaryFormat() method, 784

Binary operators, 405
 Binding notification system
 adding bindings and data, 1333
 observable models
 nameof method, 1338
 PropertyChanged event, 1336
 observable models (*see* Observable models)
 vehicle data, 1335
 BuildTableRelationship() helper function, 899
 BundleConfig, 1536

■ **C**

C# access modifiers, 179
 Callback functions, 355
 CallMeHere() method, 370
 Cancel() method, 740
 CanExecute method, 1368
 CanHelpExecute() method, 1179
 CarLotMVC project. *see* Model-View-Controller
 (MVC) pattern
 C# constructs
 arrays
 ArrayOfObjects() method, 123
 creation, 121
 GetStringArray() method, 125
 implicitly typed local arrays, 122
 initialization syntax, 121
 JaggedMultidimensionalArray(), 125
 PrintArray() method, 125
 RectMultidimensionalArray(), 125
 Reverse()/Clear() methods, 126
 SimpleArrays() method, 121
 System.Array class, 126
 System.Object.GetType() method, 123
 enum type
 definition, 128
 enumeration value, 131
 Enum.GetUnderlyingType() method, 131
 magic numbers, 129
 name-value pair, 132
 storage value, 129
 System.Enum type, 130
 underlying type, 129
 variable declaration, 129
 methods, parameter modifiers, 109
 CalculateAverage() method, 114
 DisplayFancyMessage()
 method, 117
 logical parameter, 114
 method overloading, 118
 named arguments, 117
 optional parameters, 115
 out modifier, 111

- output parameters, 113
 - positional args, 117
 - reference parameters, 113
 - by value, 110
 - by variable, 111
- nullable types
 - assignment operator, 138
 - conditional operator, 147
 - data type, 144
 - equality operator, 146
 - GetBoolFromDatabase() method, 145
 - if/else condition, 147
 - null coalescing operator, 146
 - PointRef type, 138
 - rectangle type, 139
 - SendAPersonByReference() method, 142
 - SendAPersonByValue() method, 141
 - value types *vs.* reference types, 139, 143
- structure
 - custom constructor, 135
 - default constructor, 135
 - definition, 133
 - types, 133
 - variable creation, 135
- C# dynamic keyword
 - dynamic data variable, 601
 - limitations, 604
 - practical uses, 605
 - scope, 603
- C# extension methods, 442
- Common intermediate language (CIL),
 - dynamic assemblies
- C# Iteration Constructs
 - foreach loop, 102
 - for Loop, 101
 - while and do/while loop, 103
- Class libraries
 - Configuration File Schema, 552–553
 - custom namespace
 - BinaryFormatter class, 507
 - Circle.class, 504
 - class definition, 503
 - compile-time errors, 506
 - custom alias, 507
 - default namespace, 509
 - fully qualified name, 505
 - My3DShapes namespace, 508
 - MyShapes namespace, 504
 - name clashes, 506–507
 - root namespace, 509
 - ShapesLib.cs, 503
- .NET assemblies
 - abstract base class, 515
 - Add Reference dialog box, 517
 - .assembly extern token, 518
 - assembly's metadata, 521
 - CarLibrary.dll, 521
 - C# class library, 514–515
 - C# client application, 522
 - CIL code, metadata, and assembly
 - manifest, 514
 - CLR header, 513
 - code library, 510
 - code reuse, 510
 - cross-language inheritance, 525
 - DerivedCars.cs, 516
 - embedded resources, 514
 - Exploring the CIL, 520
 - GUI editor, 519
 - GUI Properties editor, 520
 - ildasm.exe, 518
 - manifest data, 518
 - self-describing, 511
 - unique types, 510
 - versionable units, 511
 - visual basic console application, 523–524
 - Windows file header, 512
 - XML configuration files, 511
- Private assemblies
 - App.Config File, 529–530
 - Configuration files, 527
 - CSharpCarClient.exe, 528
 - MyLibraries subdirectory, 528
 - privatePath attribute, 529
 - probing process, 526
 - version number, 526
- publisher policy assemblies
 - disable policy, 548
 - input parameters, 548
 - <codeBase> element, 549
 - publickeytoken value, 550
- Shared Assemblies
 - AssemblyInfo.cs file, 535
 - assembly-level attributes, 534
 - assembly manifest, 542
 - bindingRedirect, 546
 - CarLibrary 2.0.0.0, 544–545
 - command prompt, 535
 - configuration files, 542
 - Console window, 540
 - current version, 543
 - digital signature, 534
 - gacutil.exe, 539
 - higher libraries, 533
 - historical GAC, 532
 - MyTestKeyPair.snk, 535
 - referenced library, 540
 - SharedCarLibClient, 541
 - SharedCarLibClient.exe, 547
 - *.snk file, 538

- Class libraries (*cont.*)
 - strong name, 533
 - Visual Studio, 537
 - System.Configuration namespace, 550
- ClearErrors() method, 867
- Client-side scripting, 1395
- CloneMe() method, 277
- CloseConnection() method, 838
- Collection Classes
 - arrays, 315
 - generic collections (*see* Generic collections)
 - nongeneric collections (*see* Nongeneric collections)
 - System.Collections
 - ArrayList, 318
 - Classes, 319
 - key interfaces, 317
 - types, 317
 - types, 316
- ColorChanged() method, 1198
- Commit() method, 854
- Common Intermediate Language (CIL), 520
 - AppDomain.DefineDynamicAssembly() method, 688
 - AppDomain.DefineDynamicModule() method, 688
 - attributes, 653
 - benefits, 12
 - Calc class, 10
 - CILCarClient.exe, 681
 - CILCars.dll, 678
 - C# keywords, 669
 - CreateMyAsm() method, 691
 - create MyAssembly.dll, 685
 - custom constructor, 690
 - data type mapping, 669
 - define constructor, 671
 - DefineDefaultConstructor() method, 690
 - define field data, 670
 - directives and attributes, 653
 - assembly declaration, 663
 - CILTypes assembly, 664
 - CILTypes.il file, 668
 - .class Directive, 666
 - common assembly-level directives, 664
 - CTS structure, 667
 - define class type, 665
 - enum attribute, 667
 - external assemblies, 663
 - generic member, 668
 - implementing interface, 666
 - MyBaseClass namespace, 665
 - .namespace directive, 664
 - type parameter, 668
 - Emit() method, 690
 - .field directive, 670
 - HelloWorld class type, 689
 - member parameter, 672
 - mnemonic distinction, 654
 - ModuleBuilder Type, 688
 - Module Set, 688
 - motivations, 652
 - .NET application, 652
 - .NET class library, 669
 - opcodes, 653–654
 - iteration constructs, 677
 - local variable declaration, 675
 - mapping parameters, 676
 - .maxstack directive, 675
 - member implementation, 673
 - nonstatic method, 677
 - Pop-Centric, 674
 - Primary Stack-Centric, 674
 - this reference, 677
 - OpCodes.Call method, 690
 - platform-specific instructions, 12
 - properties and methods, 671
 - pushing and popping, 654
 - round-trip engineering
 - branching/looping constructs, 659
 - C# console app., 656
 - code labels, 659
 - common ilasm.exe, 661
 - default constructor, 658
 - HelloProgram.il file, 657, 662
 - *.il file, 660
 - load-centric, 659
 - MessageBox.Show() method, 661
 - mscorlib, 660
 - peverify.exe, 662
 - SayHello() method, 691
 - string member variable, 689
 - System.AppDomain type, 686
 - System.Reflection.Emit.ILGenerator, 684
 - System.Reflection.Emit namespace, 683
 - TypeAttributes enumeration, 689
- Common Language Runtime (CLR), 4
 - definition, 20
 - key difference, 20
 - mscorlib.dll, 21
- Common Language Specification (CLS), 4
 - compliance, 20
 - programming constructs, 18
 - rules, 19
- Common Type System (CTS), 4, 1024
 - class types, 15
 - delegate types, 17
 - enumeration types, 16

- interface types, 15
- intrinsic data types, 18
- structure types, 16
- type members, 17
- Comparison operators, 410
- Component Object Model (COM), 3
- ConfigureGrid() function, 1216
- Console.WriteLine() method, 395
- Contact() action method, 1542
- ControlTemplate class, 1316
- Convert() method, 1214
- ConvertBack() method, 1214
- Cookie
 - CookieStateApp, 1514–1516
 - definition, 1514
 - HttpCookie.Expires property, 1515
 - HttpRequest.Cookies property, 1515–1516
- C# parameter modifiers, 110
- C# programming
 - BigInteger data type, 82
 - class hierarchy, 78
 - conditional operators, 105
 - data type conversion
 - checked keyword, 94
 - class Program, 91
 - implicit widening, 92
 - narrowing operation, 92
 - project-wide overflow/underflow data checking, 96
 - unchecked keyword, 96
 - if/else statement, 104
 - implicitly typed local variables
 - DeclareExplicitVars() method, 97
 - restrictions, 98
 - strongly typed data, 99
 - uses, 100
 - intrinsic data types, 74, 77
 - iteration constructs (*see* C# Iteration Constructs)
 - Main() method (*see* Main() method)
 - numerical system type, 79
 - parsing values, 81
 - Relational/Equality Operators, 104
 - SimpleCSharpApp, 61
 - switch statement, 105
 - System.Boolean data type, 80
 - System.Char type, 80
 - System.Console Class (*see* System.Console Class)
 - System.DateTime, 81
 - System.Environment Class (*see* System.Environment Class)
 - System.String
 - basic string manipulation, 84
 - concatenation, 85
 - escape characters, 86
 - immutability, 88
 - members, 84
 - StringBuilder, 89
 - string equality, 88
 - string interpolation, 90
 - verbatim string, 87
 - System.TimeSpan, 81
 - variable declaration, 75
- C# programming language
 - anonymous types
 - definition, 424
 - equality, 427
 - internal representation, 425
 - ToString() and GetHashCode() implementation, 427
 - custom type conversions
 - class types, 412
 - custom conversion routines, 413
 - explicit conversions, Square type, 416
 - implicit conversion routines, 417
 - numerical conversions, 412
 - extension methods
 - definition, 419
 - importing, 421
 - IntelliSense of, 422
 - interfaces, 422
 - invoking of, 420
 - indexer definition, on interface types, 404
 - indexer methods, 399
 - multiple dimensions, 403
 - overloading, 402
 - string index values, 401
 - operator overloading
 - binary operators, 405
 - equality operators, 409
 - MiniVan class, 411
 - += and -= operators, 408
 - unary operators, 408
 - pointer types
 - field access, 435
 - keywords, 430
 - pinning reference, 436
 - sizeof Keyword, 437
 - stackalloc Keyword, 435
 - unsafe (and safe) swap function, 434
 - unsafe keyword, 431
- Create() action method, 1552, 1596
- CreateDataReader() method, 922
- CurrentNumberChanged() method, 1226
- Custom commands
 - AddCarCommand
 - command class, 1373
 - XAML, 1374
 - CommandManager
 - creating CommandBase class, 1370
 - updating ChangeColorCommand Class, 1370

- Custom commands (*cont.*)
 - ICommand interface, 1367
 - RemoveCarCommand
 - command class, 1372
 - XAML, 1373
 - testing application, 1370
 - updating MainWindow.xaml, 1369
 - updating MainWindow.xaml.cs, 1368
- CustomDepPropApp, 1222
- Custom Generic
 - default keyword, 349
 - DisplayBaseClass<T> method, 346
 - Point<T> types, 347
 - Swap<T> method, 344, 346
 - type parameters, 346
- Custom method, 385
- C# Windows OS
 - .NET Framework documentation system, 50
 - Visual Studio 2015 Professional IDE, 50
 - Visual Studio Community, IDE
 - Class Designer Toolbox, 48
 - Class Details window, 47–48
 - class diagram file, 46
 - Class Diagram viewer, 47
 - class visualization, 49
 - project types, 45
 - Visual Studio Express, IDEs
 - Add Reference, 42
 - Express for Web, 44
 - members, 36
 - new project creation, 37
 - Object Browser, 41
 - Project Properties window, 43
 - setting breakpoints, 39
 - Solution Explorer, 40
 - tools, 36

D

- Data adapters
 - filling DataSet with single table, 888–890
 - mapping database names to friendly names, 890–891
 - members, DbDataAdapter class, 888
 - multitabled DataSet objects and data relationships, 897–898
 - properties, 888
 - strongly typed, 913–914
- Data annotations
 - ErrorTemplate, 1365
 - System.ComponentModel.DataAnnotations, 1363
 - validation errors, 1363
- DataColumn
 - adding objects, 866
 - autoincrementing fields, 865
 - development, 864
 - properties, 863–864
- Data provider factory model
 - <connectionStrings> element, 828
 - DbProviderFactory, 823
 - drawback, 827
 - Main() method, 825
 - System.Configuration.dll, 824
 - System.Data.Common namespace, 823
 - System.Data.OleDb, 826
- DataRowExtensions.Field<T>() extension method, 926
- DataRows
 - DataRowVersion property, 869
 - DataTable.NewRow() method, 867
 - key members, 866–867
 - RowState property, 868
- DataSet
 - anatomy, 861
 - development, 863
 - ExtendedProperties property, 861
 - LINQ (*see* LINQ programming)
 - methods, 862
 - properties, 861–862
 - Tables property, 861
- DataSet Extensions Library, 923–924
- DataTable.NewRow() method, 867
- DataTableReader objects, 873–874
- DataTables
 - binding Windows Forms GUI
 - DataView type, 885–887
 - deleting rows, 881–882
 - hydrating from generic List, 878–880
 - initial GUI, 878
 - selecting rows, 882–884
 - updating rows, 885
 - inserting into DataSets, 871
 - key members, 871
 - LINQ programming, 927
 - obtaining data in DataSet, 872
 - processing using DataTableReader objects, 873–874
 - serializing in binary format, 876–877
 - serializing as XML, 874–876
- DbDataAdapter class, 888
- Default application domain
 - AssemblyLoad event, 640
 - loaded assemblies, 639
- Default constructor, 157
- Delegate.Combine() method, 367
- Delegate type
 - BeginInvoke() method, 357
 - BinaryOp class, 357, 362
 - C# anonymous methods
 - AboutToBlow event, 386
 - accessing local variables, 387

- Car class, 385
 - pseudocode, 386
- C# events
 - Accelerate() method, 376
 - add_Exploded() method, 377
 - boilerplate code, 374
 - CarDelegate, 374
 - CarEngineHandler objects, 375
 - CarEvents, 376
 - cleaning up event invocation, 381
 - custom event arguments creation, 382
 - custom method, 385
 - event registration, 380
 - Generic EventHandler<T> Delegate, 384
 - incoming events, 378
 - registration and unregistration methods, 376
 - remove_Exploded() method, 377
- definition, 356
- delegate object, 361–362
- EndInvoke() method, 357
- GenericDelegate, 371
 - generic Action<> and Func<> delegates, 372
 - MyGenericDelegate<T>, 371
 - StringTarget() method, 372
- Invoke() method, 357
- Main() method, 361
- MyDelegate, 358
- MyOtherDelegate, 358
- object state notifications
 - Accelerate() method, 365
 - CarDelegate, 364
 - CarEngineHandler, 364
 - listOfHandlers, 364
 - Main() method, 366
 - method group conversion syntax, 369
 - multicast enable, 366
 - OnCarEngineEvent() method, 366
 - Program class, 365
 - RegisterWithCarEngine() helper method, 365
 - RegisterWithCarEngine() method, 364
 - Remove() method, 368
 - updates, 364
- pseudocode, 358
- SimpleDelegate, 360
- SimpleMath, 361
- SquareNumber() method, 361
- System.Delegate base classes, 359
- System.MulticastDelegate, 356, 359
- Delete() action methods, 1556, 1598
- DeleteAsync() extension method, 1599
- DeleteCar() method, 850
- Delete()/DeleteAsync() methods, 1574
- DependencyProperty.Register() method, 1219–1220
- Dequeue() method, 338
- Details() action method, 1551, 1596

- Disconnected functionality
 - configuring the data adapter, 892–893
 - defining Initial Class Type, 892
 - implementing GetAllInventory(), 894
 - implementing UpdateInventory(), 894
 - setting version number, 894
 - testing, 894–896
- Disconnected layer. *see* DataSet
- DisplayDefiningAssembly(), 420
- DisplayDelegateInfo() method, 362
- DisplayMessage() method, 373
- DisplayTable() helper method, 849
- Dispose() method, 1549, 1558, 1588
- Distributed Component Object Model (DCOM), 1022
- Distributed system, 1021
- Download cache, 549
- DownloadStringAsync() method, 735
- DoWork() method, 742, 744
- Dynamic data
 - COM interop pain points, 614
 - COM interop using C#, 615
 - COM interop without C#, 619
 - interop metadata, 613
 - primary interop assemblies, 612
- Dynamic Language Runtime (DLR)
 - expression trees, 606–607
 - System.Dynamic Namespace, 606

■ E

- Edit() action methods, 1549, 1554, 1555, 1597
- Enable() method, 1206
- EnableAnnotations() method, 1206
- Encapsulation
 - automatic properties
 - default values, 192
 - DisplayStats() method, 192
 - expected property syntax, 192
 - initialization of, 194
 - read-only automatic property, 191
 - syntax, 191
 - write-only property, 191
- C# access modifiers, 179
- C# class type
 - Car variable, 154
 - insertion, 152
 - member variables, 151
 - objects allocation, 154
 - PrintState(), 153
 - SpeedUp(), 153
- class definition, 181
- constant field data, 199
- constructors
 - custom constructors, 156
 - default constructor, 155

Encapsulation (*cont.*)

- keyword
 - constructor chaining, 161
 - constructor flow, 163
 - IntelliSense, 160
 - Main() method, 160
 - optional arguments, 165
 - SetDriverName(), 159
 - .NET properties, 184
 - object initialization syntax
 - custom constructors, 197
 - initializing data, 198
 - objectInitializers, 196
 - point objects, 196
 - OOP
 - Draw() method, 178
 - encapsulation, role of, 175
 - “has-a” relationship, 176
 - inheritance, role of, 175
 - “is-a” relationship, 176
 - polymorphism, 177
 - partial classes, 202
 - properties, 187
 - read-only property, 189
 - static keyword
 - importing static members, 174
 - static classes, 173
 - static constructors, 170
 - static field data, 167
 - static methods, 169
 - utility classes, 166
 - WriteLine() method, 166
 - static properties, 190
 - traditional accessors and mutators, 182
 - write-only property, 189
- EndInvoke() method, 357–358, 700
- Enqueue() method, 338
- EnterLogData() method, 115
- Entity data model (EDM), 932
- Entity data model XML (EDMX) file, 929
- Entity framework
 - AddRecords() method, 930
 - AutoLotConsoleApp
 - ADO.NET EDM project item
 - insertion, 939
 - AutoLotConnection, 940
 - configSection, 944
 - Customer and Orders relationship, 944
 - data annotations, 942–943
 - database selection, 940–942
 - DbSet<TEntity> property, 944
 - default mappings, 945
 - designer-generated classes, 946
 - EDM generation, 940

- entity names, 942
 - FluentAPI, 944
 - Key attribute, 943
 - Order class, 943
 - Orders and Inventory relationship, 944
 - StringLength attribute, 943
 - SuppressMessage attributes, 943
 - table attribute, 943
- AutoLotDAL Version 4 (*see* AutoLotDAL Version 4)
- AutoLot database, Inventory table, 932
- building blocks
 - DbContext class, 935–936
 - DbSet<T>, 936
 - empty code first model, 937
 - Entity State, 937
 - System.Data.Entity.dll assembly, 934
 - transaction support, 937
- concurrency, 991
- connected layer, 930–931
- convention and configuration, 932
- DataSet class, 930
- disconnected layer, 930–931
- EDM, 932
- EDMX file, 929
- goal, 929
- in-house application, 931
- interception
 - ConsoleWriterInterceptor, 994
 - DatabaseLogger interceptor, 995
 - IDbCommandInterceptor interface, 993
 - registering, 995
 - WriteInfo() method, 994
- LINQ queries, 929–930
- LINQ to SQL, 931
- migrations
 - baseline migration, 985
 - concurrency checking, 982
 - Credit Risk class, 984
 - Customer class, 983
 - Inventory class, 982
 - __MigrationHistory table, 985
 - Order class, 983
 - Seed() method, 989
 - System.InvalidOperationException, 984
 - Timestamp property, 982
- model classes (*see* Model classes)
- ObjectContext class
 - accessing, 996
 - ObjectMaterialized event, 996
 - SavingChanges event, 997
- POCO classes, 932
- runtime, 931
- SQL Server Express, 998

table adapter supports methods, 930
 transaction test, 990
 Entity Framework (EF), 802
 ExecuteNonQuery() method, 837
 ExecuteReader() method, 837

F

File I/O

BinaryReader object, 772
 BinaryWriter object, 772
 Directory.GetLogicalDrives() method, 756
 DirectoryInfo.CreateSubdirectory()
 method, 754–755
 DirectoryInfo Type, 752
 DriveInfo.GetDrives() method, 757
 File types, 762
 FileAccess enumeration, 760
 file-centric members, 763
 FileInfo.AppendText() method, 762
 FileInfo class, 758
 FileInfo.Create() method, 759
 FileInfo.CreateText() method, 762
 FileInfo.Open() method, 759, 761
 FileInfo.OpenText() method, 761
 FileInfo types, 762
 FileMode enumeration, 760
 FileShare enumeration, 760
 FileStream object, 759
 FileSystemEventHandler, 774
 FileSystemInfo type, 750
 FileSystemInfo Base Class, 751
 FileSystemWatcher type, 774
 GetFiles() method, 754
 GetStringBuilder() method, 771
 MemoryStream object, 773
 MyFolder directory, 774
 Stream class
 CreateText() method, 768
 File.CreateText() method, 768
 FileStreams type, 765
 StreamReader types, 770
 StreamWriter type, 767, 770
 StringReader type, 767
 TextReader class, 769
 TextWriter class, 767
 StringReader object, 770
 StringWriter object, 770
 System.IO namespace, 749
 System.IO.NotifyFilters enumeration, 774
 Fill() method, 810
 FilterConfig, 1537
 FormatNumericalData() function, 72

G

Generic collections

benefits, 327
 type parameters
 constraints, 350
 generic class/structure, 328
 generic interfaces, 330
 generic items, 327
 generic members, 330
 operator constraints, 352
 where clause, 351

GetAllInventory(), 894
 GetAllInventoryAsList() method, 850
 GetChildren() method, 1313
 GetCoffee() funtion, 338
 GetCommandLineArgs() method, 66
 GetErrors method, 1359
 GetInventory() method, 1077, 1589
 GetInventory(int id) method, 1589, 1592
 GetOneAsync() method, 970, 1592
 GetOne() method, 970
 GetPerson(), 401
 GetValue() method, 1219
 Global.asax.cs file, 1534
 Global assembly cache (GAC), 532
 Globally unique identifier (GUID), 534, 863
 Graphical rendering, WPF
 adding rectangles, ellipses, and
 lines, 1233–1236
 brushes and pens
 Brush-derived types, 1243
 configuring in code, 1247–1248
 configuring pens, 1248
 configuring using visual
 studio, 1243, 1245, 1247
 drawings and geometries
 building DrawingBrush using
 geometries, 1259–1260
 containing drawing types in
 DrawingImage, 1261–1262
 Drawing class, 1258
 Drawing-derived types, 1258–1259
 DrawingImage, 1259
 Drawing vs. Shape types, 1259
 painting with DrawingBrush, 1260–1261
 graphical transformations (*see* Graphical
 transformations)
 options, 1230
 path
 Geometry-derived classes, 1239–1240
 key members, 1239
 mini-language, 1241–1242

Graphical rendering, WPF (*cont.*)
 polylines and polygons, 1238
 removing rectangles, ellipses,
 and lines, 1236–1238
 Shape base class, 1231–1233
 vector images (*see* Vector images)
 visual layer (*see* Visual layer)
 Visual Studio transform editor (*see* Visual
 Studio transform editor)

Graphical transformations
 adding a final <ToggleButton>, 1251
 adding final Boolean member
 variable, 1252–1253
 Button with skew transformation, 1250
 Click event handler, 1251
 Ellipse scaled by 20%, 1250
 Rectangle with rotate transformation, 1250
 rendering entire <DockPanel>, 1251
 TextBox responsive to keyboard input, 1250
 TextBox rotated and skewed, 1250
 Transform-derived classes, 1249
 undefined clipping region, 1252

■ H

HasErrors property, 867
 HelpExecuted() method, 1179
 HTML
 definition, 1388
 document structure, 1388
 form, 1390, 1394
 Visual Studio, 1390

HTTP
 browser statistics, 1422
 btnGetFormData_OnClick value, 1425
 HttpRequest class type, 1421
 HttpRequest.Form property, 1425
 HttpRequest.QueryString property, 1425
 HttpResponseMessage type
 HttpResponseMessage.Write() method, 1427
 HttpResponseMessage.WriteFile() method, 1427
 methods, 1427
 properties, 1426
 users redirection, 1427
 IsPostBack property, 1426
 MapPath() method, 1422
 request/response cycle, 1385
 SaveAs method, 1422
 stateless protocol, 1386
 Text property, 1425
 ValidateInput() method, 1422
 HttpRequest.Browser property, 1396

■ I

IAsyncResult interface, 700
 IDbCommand interface, 808
 IDbDataAdapter and IDDataAdapter
 interfaces, 809
 IgnoreRoute() method, 1543
 ImageMagick tool, 1263
Immediate-mode graphical systems, 1229
 Index() action method, 1543, 1549, 1555, 1595
 Indexer methods, 399
 Inheritance and polymorphism
 abstract classes, 225
 base/derived class, 234
 basic mechanics, 205
 Car class, 206
 containment/delegation
 GetBenefitCost(), 217
 “has-a” relationship, 217
 Main() method, 218
 nested type definitions, 218
 controlling base class, 213
 Employee.cs and Employee.Core.cs files, 212
 GiveBonus(), 220
 “is-a” relationship, 205, 217
 Manager class, 212
 master parent class
 Main() method, 240
 ObjectOverrides, 239
 person class, 243
 static members, 244
 System.Object, 238, 240
 System.Object.Equals(), 241
 System.Object.GetHashCode(), 242
 System.Object.ToString(), 240
 multiple base classes, 208
 parent class, 206
 polymorphic interface
 abstract methods, 230
 Draw() method, 229–230
 Main() method, 230–231
 shadowing, 232
 shapes hierarchy, 228
 virtual and abstract methods, 228
 protected keyword, 215
 SalesPerson class, 212
sealed class, 216
 sealed keyword, 208
 sealing virtual members, 225
 virtual and override keywords, 221
 Visual Studio class diagrams, 210–211
 Visual Studio IDE, 223

InitializeComponent() method, 1178
 INotifyPropertyChanged interface, 1336
 InsertAuto() method, 843, 850, 1079
 InsertCar() method, 1077
 InsertNewElement() method, 1016

Interfaces

- abstract base classes, 278
- abstract members, 275
- arrays, 288–289
- CloneMe() method, 285
- cloning process
 - class named Point, 302–304
 - ICloneable interface, 303
 - MemberwiseClone() method, 304
 - PointDescription type, 304–307

custom interfaces

- access modifier, 279
- class/structure, 280
- compiler errors, 280
- IPointy, 279
- namespace, 279
- read-only property, 280

explicit interface implementation

- Draw() method, 291, 293
- InterfaceNameClash, 291
- Octagon type, 292

Hexagon type, 283

IComparable interface

- Car class, 307–308
- custom static property, 311–312
- definition, 307
- int data type, 309
- internal CarID, 308
- return values, 309
- sort order, 310–311
- System.Array class, 308

IDbConnection, 275

IDraw3D interface, 286–287

IEnumerable and IEnumerator

- array type, 297
- Garage, 297–298
- GetEnumerator() method, 298
- iterator method, 300
- named iterators, 301–302
- System.Collections namespace, 299

implementation, 281–282

InterfaceHierarchy

- BitmapImage, 294
- drawing behavior, 294
- IAdvancedDraw, 294
- MIInterfaceHierarchy, 295–296
- rendering-centric interfaces, 293

InvalidCastException, 283

Main() method, 283–285

method return values, 287–288

null reference, 284

ThreeDCircle and Hexagon, 285

types, 276–278

Visual Studio class diagram, 286

Visual Studio support, 289–290

Interlocked.Exchange() method, 723

Internet Information Services (IIS)

- Default Web Site node, 1386

- Express, 1387

- virtual directories, 1387

Inventory() method, 1591

InventoryList

- Clear method, 1343

- NotificationCollectionChangedAction.Add value, 1342

- NotificationCollectionChangedAction.Remove value, 1343

- OnCollectionChanged method, 1341

- RemoveAt method, 1343

Invoke() method, 357–358, 361, 698

IsEvenNumber() method, 389

■ J, K

JavaScript Object Notation (JSON), 1586, 1591

■ L

Lambda expressions

- dissection, 391

- lambdas and single statement member implementations, 395

- multiple/zero parameters, 393

- processing arguments, multiple statements, 392

- retrofitting CarEvents, 395

- SimpleLambdaExpressions, 388

LambdaExpressionSyntax() method, 392

Language Integrated Query (LINQ), 5

LayoutTransform property, 1249

LinqOverDataTable() method, 923

LINQ programming

- DataRowExtensions.Field<T>() extension method, 926

- DataSet Extensions Library, 923–924

- hydrating new DataTables, 927

- LINQ-compatible DataTable, 924–926

LINQ programming model

- aggregation operations, 465

- anonymous types, 443

- C# LINQ query operators, 457, 459

- Count() extension method, Enumerable class, 462

- data types, 460

- removing duplicate, 465

- Reverse<>() extension method, 462

LINQ programming model (*cont.*)
 selection syntax, 459
 sorting expression, 463
 subsets of data, 460
 Core LINQ assemblies, 444
 data, API uses, 443
 DataSet, 444
 entities, 444
 expressions, 444
 extension methods, 442
 Lambda expressions, 441
 local variables, 440
 object and collection initialization syntax, 440
 queries, 444
 and extension methods, 449
 and local variables, 448
 contained subobjects, 455
 deferred execution, 450
 enumerable type and anonymous
 methods, 469
 enumerable type and lambda
 expressions, 467
 enumerable type and raw delegates, 469
 filtering data, `OfType<T>()`, 457
 immediate execution, role of, 451, 453
 nongeneric collections, 456
 query expression, 446
 query operators, 467
 `QueryOverStrings()` method, 445, 447
 result set, 447
 Venn Diagramming Tool, 463
 XML, 444
 LINQ technology, 429
 LINQ to SQL, 931
 LINQ to XML
 In-Memory XML document
 GUI, 1014
 Helper class, 1016
 Inventory.xml file, 1015
 Windows Forms application, 1014
 Inventory.xml file, 1002
 LinqToXmlFirstLook project, 1001
 System.Xml.dll assembly, 1001
 System.Xml.Linq namespace, 1003
 axis methods, 1008
 class hierarchy, 1007
 members, 1007
 XNamespace, 1009
 top-down code, 1003
 VB literal syntax, 1004
 XElement and XDocument
 arrays and containers, 1012
 example, 1010
 hypothetical style sheet, 1012
 inventory items, 1011

 Load() and Parse() methods, 1014
 SimpleInventory.xml file, 1011
 UTF-8 encoding, 1011
 XmlDocument and XmlElement classes, 1002
 XML document creation, 1002
 ListInventory() method, 849
 Load() method, 842
 LogicalTreeHelper class, 1313
 LookUpColorsForMake() method, 1017

■ M

MagicEightBallServiceLib., 1038
 Main() method, 361–362, 366, 394, 699, 702, 717,
 825, 833, 847
 application error code, 64
 command-line arguments, 65
 Program class, 62
 refactored, 378
 variations, 63
 MapPath() method, 1422
 MapRoute() method, 1543
 Metadata exchange (MEX), 1047
 Method overloading
 Add() method, 119
 class definition, 119
 IntelliSense list, 120
 Microsoft Message Queuing (MSMQ), 1023
 Microsoft .NET platform
 assembly manifest, 14
 assembly/namespace/type distinction, 22
 base class libraries, 5
 CIL (*see* Common Intermediate Language
 (CIL))
 CLI Partitions, 31
 CLR (*see* Common Language Runtime (CLR))
 CLS (*see* Common Language Specification (CLS))
 Common Language Runtime, 4
 Common Language Specification, 4
 Common Type System, 4
 COM programming model, 3
 C# programming language, 6
 features, 4
 ildasm.exe, 28
 CIL code, 29
 manifest data, 30
 metadata, 30
 IL instructions, 9
 managed *vs.* unmanaged code, 7
 metadata, 9
 Mono project, 32
 multilanguage applications, 8
 namespace programming, 25
 .NET Core framework, 32
 .NET Distributions, 32

- .NET metadata, 13
- .NET Namespaces, 24
- root namespace, 23
- Windows\Assembly\GAC, 26
- Microsoft Transaction Server (MTS), 1023
- Model classes
 - DbSet<Car> collection, 948
 - LINQ queries, 949
 - Main() method, 948
 - navigation properties
 - eager loading, 952
 - explicit loading, 953
 - JOIN operations, 951
 - lazy loading, 952
 - virtual ICollection<Order>, 951
 - PrintAllInventory() method, 948
 - record deletion
 - EntityState, 954
 - Find() method, 954
 - record insertion, 947
 - record update, 955
 - SqlQuery, 949
- Model-View-Controller (MVC) pattern
 - adding, 1529
 - ASP.NET Web Forms, 1528
 - AutoLotDAL project, 1545
 - components
 - App_Start folder, 1536
 - ASP.NET folders, 1535
 - Bootstrap, 1538
 - Content folder, 1538
 - Controllers folder, 1534
 - Fonts folder, 1538
 - Models folder, 1534
 - project root files, 1533
 - Scripts folder, 1538
 - Views folder, 1535
 - controllers and actions, 1528
 - ActionResult-Derived classes, 1550
 - Create() action method, 1552
 - Delete() action methods, 1556
 - Details() action method, 1551
 - Dispose() method, 1549, 1558
 - Edit() action method, 1549, 1555
 - inventory repository, 1550
 - Index() method, 1549–1550
 - inventory controller, 1546
 - InventoryController.cs class, 1549
 - Web start action updation, 1549
 - convention over configuration, 1529
 - Create view
 - add inventory view, 1574
 - AntiForgery token, 1572
 - BeginForm() HTML helper, 1572
 - Bootstrap, 1573
 - EditorFor() HTML helper, 1571
 - LabelFor helper, 1572
- Delete view, 1574
- Details view, 1570
- Edit view, 1576
- home page updation, 1581
- Index view
 - data annotations, 1565
 - DisplayFor(), 1565
 - DisplayNameFor() HTML helper, 1565
 - GlyphIcons, 1568
 - header update, 1566
 - updated table, 1567
- layouts, 1561
- Layout view updation, 1580
- model, 1527
- MVC5, 1529
- MVVM, 1527
- NuGet Packages updation, 1539
- partial views, 1563
- project creation
 - authentication options, 1531
 - generated files and folders, 1533
 - new ASP.NET web application, 1530
 - selection, 1531
- Razor View Engine, 1558
 - HTML helpers, 1559
 - Razor delegates, 1560
 - Razor functions, 1560
 - Razor syntax, 1558
- removing, 1529
- routing
 - ActionLink() HTML helper, 1544
 - Contact() action method, 1542
 - creation, 1543
 - _Layout.cshhtml file, 1544
 - URL patterns, 1542
- strongly type views, 1565
- TempData, 1564
- test-drive, 1540
- validation
 - client-side, 1579
 - server-side, 1578
- ViewBag, 1564
- ViewData, 1564
- view models, 1565
- Model-View-ViewModel (MVVM) pattern, 1527
 - anemic models, 1331
 - application, 1329–1330
 - AutoLotDAL
 - base class, 1376–1377
 - INotifyPropertyChanged, 1378–1379
 - inventory partial, 1377–1378
 - ConnectionStrings node, 1379
 - definition, 1330

Model-View-ViewModel (MVVM) pattern (*cont.*)
 implementation
 Button Command binding
 statements, 1376
 data source, 1374
 ObjectMaterialized event, 1380
 Module-level attributes, 585
 Monitor.Enter() method, 722
 Multitabled DataSet objects and data relationships
 building table relationships, 899
 displaying data, 896–897
 navigating between related tables, 900
 Button’s Click event handler, 900–901
 output when specifying customer ID, 901
 UI for customer order information, 900
 preparation, 897
 preparing data, 897–898
 updating database tables, 899
 Multithreaded application
 AutoResetEvent class, 715
 background threads, 716
 foreground threads, 716–717
 OS/CLR, 697
 ParameterizedThreadStart delegate, 714
 synchronization, 697
 attribute, 724
 C# lock keyword, 719
 System.Threading.Interlocked Type, 723
 System.Threading.Monitor class, 722
 synchronizing threads, 718
 System.Threading namespace, 696
 ThreadStart Delegate, 712
 MyLocalVariables() method, 675

■ **N**

nameof method, 1338
 NarrowingAttempt() method, 94
 .NET delegate, 697
 .NET platform
 context-agile and context-bound
 types, 646
 context-bound object, 647
 new application domains
 custom application domains, 643
 programmatically unloading
 AppDomains, 644
 object’s context inspection, 647
 process’s module set, 632
 process’s thread set, 630
 programmatically launch and terminate
 process, 633
 running processes, 628
 Start() method, 634

 static Process.GetProcessById() method, 629
 System.AppDomain Class, 636
 System.Diagnostics namespace, 626
 system.diagnostics.process, 627
 Nongeneric collections
 issue of performance, 320
 issue of type safety, 323

■ **O**

Object generations, 479
 Object lifetime
 application roots, 477
 CIL newobj instruction, 475
 classes, objects, and references, 473
 concurrent background garbage
 collection, 480
 concurrent garbage collection, 480
 disposable objects, 488
 finalizable and disposable types, 492
 finalizable objects
 finalization process, 488
 Overriding System.Object.Finalize(), 486
 lazy object instantiation, 495
 MakeACar() method, 475
 object generations, 479
 setting object references to null, 477
 System.GC Type
 garbage collection, 482
 member selection, 481
 Object-oriented programming (OOP), 175
 Draw() method, 178
 encapsulation, role of, 175
 “has-a” relationship, 176
 inheritance
 controlling base class, 213
 Employee.cs and Employee.Core.cs
 files, 212
 Manager class, 212
 protected keyword, 215
 SalesPerson class, 212
 sealed class, 216
 inheritance, role of, 175
 “is-a” relationship, 175
 polymorphic
 abstract classes, 225
 abstract methods, 230
 Draw() method, 230
 GiveBonus(), 220
 Main() method, 231
 sealing virtual members, 225
 shadowing, 232
 shapes hierarchy, 228
 virtual and abstract methods, 228

- virtual and override keywords, 221
- Visual Studio IDE, 223
- polymorphism, 177
- ObjectResourcesApp, 1295
- Object Serialization
 - customize serialization process, 796
 - Formatter
 - BinaryFormatter type, 781, 783
 - Deserialize() method, 782
 - IFormatter type, 781
 - IRemotingFormatter interfaces, 781
 - Person type, 783
 - Serialize() method, 782
 - SoapFormatter type, 781, 786
 - type fidelity, 782
 - XmlSerializer type, 781, 787
 - GetObjectData() method, 793
 - ISerializable interface, 793–794
 - ISerializable object, 793
 - MyStringData, 795
 - object graph, 778
 - Object set, 790
 - private fields, 780
 - public fields, 780
 - public properties, 780
 - Serializable Types, 779
 - SerializationInfo parameter, 793
 - StreamingContextStates enumeration, 794
 - string data, 794
 - System.Object, 790
 - System.Runtime.Serialization namespace, 792
 - UserPrefs class, 776
- Observable models
 - collections
 - dirty flag, 1345
 - IList<Inventory> (see InventoryList)
 - Inventory class, 1333
 - MainWindow.xaml.cs, 1344
 - Notifications, 1332
 - NotifyCollectionChangedEventArgs enum Values, 1339
 - NotifyCollectionChangedEventArgs Constructor Options, 1339
 - UpdateSourceTrigger values, 1347
 - INotifyPropertyChanged event, 1337
 - INotifyPropertyChanged interface, 1336
 - OnPropertyChanged helper method, 1337
 - PropertyChangedEventArgs constructor, 1336
- Ok() method, 1592
- OnCarEngineEvent() method, 366
- OnPropertyChanged helper method, 1337
- OnStart() method, 1067
- OnStop() method, 1067
- OnTransformDirty() method, 1220
- OpenConnection() method, 838

P

- Parallel.ForEach() method, 728
- Parallel.For() method, 728
- Parallel.Invoke() method, 738
- Parallel LINQ Queries (PLINQ), 695
 - AsParallel() extension method, 739
 - cancellation, 740
 - nonparallel* version, 739
 - ParallelEnumerable Class, 738
- Parallel programming
 - CancellationTokenSource class, 733
 - data parallelism, 729
 - System.Threading.Tasks
 - namespace, 728
 - System.Threading.Tasks.Parallel class, 728
 - Task class, 732
 - task parallelism, 735
 - Task Parallel Library* (TPL), 727
 - thread affinity, 731
- ParseFromStrings() method, 81
- PartialView() method, 1563–1564
- plain old CLR objects (POCOs), 1527
- Polymorphism, 177
- PopulateDocument() method, 1203
- PostAsJsonAsync() extension method, 1597
- PostInventory() method, 1593
- Pre-WPF solutions, 1086
- PrintDataSet() method, 872
- PrintNumbers() method, 717–718
- PrintTime() method, 725
- ProcessCreditRisk() method, 855
- ProcessFiles() method, 731, 733
- ProcessIntData() method, 740
- PutInventory() method, 1592

Q

- Queued Components* (QC), 1023
- Queuing data, 1023

R

- Read() method, 835, 841
- RegisterWithCarEngine() method, 365–366
- Remove() method, 368
- RemoveAt method, 1343
- remove_Exploded() method, 377
- RenderTransform property, 1249
- ResetPoint() method, 349
- Retained-mode graphics, 1229
- ReverseDigits(), 419
- Rollback() method, 854
- RouteConfig, 1538
- RowState property, 868

S

- SaveAs method, 1422
- Select() method, 883
- Serviced component, 1023
- Service-oriented architecture (SOA), 1027
- Session data
 - HttpSessionState class, 1513
 - session application GUI, 1512
 - Session_End(), 1510
 - Session_Start(), 1510
 - UserShoppingCart, 1511
- SetBinding() method, 1218
- SetBindings() function, 1215
- SetF1CommandBinding() method, 1178
- SetValue() method, 1219
- ShowDialog() method, 1149
- ShowEnvironmentDetails()method, 67
- ShowInstructions() method, 849
- SimpleBoxUnboxOperation() method, 320
- Simple Object Access Protocol (SOAP), 786
- SoapFormatter type, 781
 - ref tokens, 786
 - System.Runtime.Serialization.Formatters.
 - Soap.dll, 786
- SortCars() function, 1560
- SqlCommandBuilder, 892-893
- SquareNumber() method, 361
- Static method, 362
- static Thread.GetDomain() method, 696
- static Thread.Sleep() method, 699
- StringConcatenation() function, 85
- String.Format() method, 73
- StringTarget() method, 372
- Strongly typed Data Adapter, 913-914
- Strongly typed DataRow, 912
- Strongly typed DataSet, 909-910
 - custom aspects of AutoLot, 916
 - deleting data with generated code, 920
 - inserting data with generated code, 919-920
 - inserting into new folder, 915
 - invoking stored procedure, 921
 - selecting data with generated code, 918-919
 - viewing generated code, 916-917
- Strongly typed DataTable, 911
- Structured exception handling
 - Accelerate() method, 253
 - application-level exceptions, 261
 - attributes/object serialization, 264
 - CarIsDeadException, 262-263
 - code snippet template, 264-265
 - custom exception, 261
 - prim-and-proper custom exception class, 264
 - ArgumentOutOfRangeException, 265
 - catch logic, 266
 - catch statements, 268
 - compile-time errors, 267
 - constructors, 251-252
 - containment/delegation, 251
 - data property, 258-260
 - debugging, 272-273
 - definitions, 247
 - filters, 271
 - HelpLink property, 257-258
 - inner exceptions, 269-270
 - Main() method, 252-253
 - .NET
 - building blocks, 249
 - C code, 248
 - E_FILENOTFOUND constant, 248
 - System.Exception base class, 249-250
 - WCF service, 249
 - Radio type, 251
 - rethrowing exceptions, 268-269
 - StackTrace property, 257
 - system exceptions, 260
 - TargetSite property, 256
 - try/catch block, 254-255, 270-271
 - verbose error dump, 254
- Subtract() methods, 362
- *.svc file, 1079
- svcutil.exe, 1050
- System.Collections.Generic
 - Classes, 332
 - Dictionary<TKey,TValue> type, 340
 - initialization syntax, 333
 - Key Interfaces, 332
 - List<T> class, 334
 - Queue<T> Type, 337
 - SortedSet<T> class, 338
 - Stack<T> class, 336
- System.Collections.ObjectModel
 - members, 341
 - ObservableCollection<T> class, 341
- System.Console Class
 - formatting
 - Console.WriteLine(), 71
 - numerical data, 71
 - string.Format() method, 73
 - input and output, 69
 - members, 69
- System.EnterpriseServices, 1023
- System.Environment Class
 - properties, 68
 - ShowEnvironmentDetails()method, 67
- System.IO.Stream class, 764
- System.Messaging, 1023
- System.Reflection, 1317
- System.Runtime.Remoting, 1024
- System.Threading Namespace

- CLR thread pool, 726
- core types, 708
- current thread execution, 709
- Name property, 710
- Priority property, 711
- Thread Type
 - Instance-Level Members, 709
 - Static Members, 708
- TimerCallback delegate, 725
- System.Web Namespace, 1499
- System.Windows.Markup, 1317
- System.Xml, 1317
- System.Xml.dll assembly, 1001

■ T

- Task Parallel Library (TPL), 695, 697, 727
- Themes
 - App_Theme folder, 1482
 - assigning, 1486
 - CssStyle property, 1482
 - page-by-page level, 1485
 - property settings, 1482
 - selection, 1486
 - site-wide themes, 1485
 - *.skin files, 1482
 - SkinID property, 1486
 - style sheets, 1482
- ThreadPool.QueueUserWorkItem()
 - method, 726
- Thread.Sleep() method, 698
- Thread.Start() method, 716
- TimerCallback delegate, 725
- ToArray() extension method, 461
- ToolsSpellingHints_Click() method, 1175
- TreesAndTemplatesApp, 1313
- TryFindResource() method, 1311
- TryUpdateModel, 1462

■ U

- Update() methods, 810
- UpdateCarPetName() method, 851
- UpdateInventory(), 894
- Update() method, 1588

■ V

- ValidateCurrentNumber method, 1225
- ValidateInput() method, 1422
- Validation
 - CardId, 1349
 - class, 1349
 - ErrorTemplate property, 1351
 - IDataErrorInfo interface, 1351

- INotifyDataErrorInfo interface
 - additional features, 1358
 - CheckMakeAndColor helper
 - method, 1358
 - code implementation, 1355
 - errors collection, 1361
 - GetErrors method, 1359
 - InventoryPartial.cs class, 1361, 1363
 - ModelT validation, 1357
 - System.Collections and System.
 - ComponentModel, 1361
 - ValidationError object, 1360
 - Label and TextBox, 1348
- Validation controls, 1470
 - client-side form validation, 1470
 - client-side JavaScript validation support, 1472
 - CompareValidator, 1473
 - data annotations
 - app testing, 1481
 - code, 1480
 - EditItemTemplate, 1478-1479
 - FormView control, 1478
 - InsertItemTemplate, 1479
 - Inventory class, 1477
 - Inventory.cs class, 1477
 - ItemTemplate, 1478
 - ModelErrorMessage control, 1477
 - layout, 1471
 - properties, 1470
 - RangeValidator, 1473
 - RegularExpressionValidator, 1472
 - RequiredFieldValidator, 1472
 - ValidationGroups.aspx, 1476
 - ValidationSummary widget, 1474
 - ValidatorCtrls web site, 1471
- ValueAndReferenceTypes() method, 137
- Vector images
 - importing graphical data, 1265-1266
 - interacting with sign, 1266-1267
 - sample vector graphic file to XAML conversion
 - folder hierarchy, 1264
 - printing, 1263-1264
 - rendered image, 1265
 - using Inkscape, 1262-1263
- Verbatim string, 87
- View() method, 1551
- Virtual execution stack, 655
- Virtual member, 177
- Visual layer
 - DrawingVisual Class, 1269-1270
 - rendering to custom layout manager, 1271-1273
 - responding to hit-test operations, 1273-1274
 - Visual Base class and derived Child
 - classes, 1268
- Visual Studio, 1388, 1390

Visual Studio transform editor
 applying transformations at design
 time, 1256–1257
 building initial layout, 1254–1255
 transforming Canvas in code, 1257

W

WCFWindows Communication Foundation (WCF)

WcfTestClient.exe, 1030

Web API project

AutoLotDAL project, 1585
 AutoLotEntities variable remove, 1594
 AutoMapper, 1584
 CarLotWebAPI
 Add action, 1596
 Delete() action methods, 1598
 Details() action method, 1596
 Edit() action methods, 1597
 Index() action method, 1595
 multiple startup projects, 1600

configuration, 1585

default route, 1585

empty project template, 1584

enables attribute routing, 1585

Global.asax.cs file, 1585

InventoryController.cs class, 1588

inventory record

addition, 1593

AutoMapper, 1590

deletion, 1594

error, Microsoft Edge browser, 1589

GetInventory(), 1589

GetInventory(int id), 1589, 1592

GetOneAsync() method, 1592

HttpActionResult, 1592

HttpResponseMessage, 1589

NotFound(), 1592

Ok() method, 1592

ResponseType attribute, 1592

updatation, 1592

JSON, 1586

model and context classes, for controller, 1588

new ASP.NET web application, 1583

new Web API 2 Controller, 1587

NuGet packages, 1584

RouteParameter.Optional, 1585

web application, 1386

web.config file, 1079

Web controls

AutoPostBack property, 1437

btnAddWidgets button, 1442

btnClearPanel button, 1442

Button control, 1436

categories, 1444

C# code, 1440

data-centric controls, 1446

documentation, 1448

dynamic controls

btnGetTextData button, 1442

enumeration, 1441

lblTextBoxData, 1442

text boxes, 1442–1443

WebControl base class, 1443

web page, 1439

HTML description, 1438

Label control, 1440

<asp\:TextBox> tag, 1435

server-side <script> block, 1436

Page_Load() event, 1440

Panel control, 1438

security, 1447

server-side event handling, 1436

standard, 1445

System.Web.UI.Control

members, 1438

property, 1438

System.Web.UI.HtmlControls, 1448

System.Web.UI.LiteralControl, 1440

System.Web.UI.WebControls, 1435

validation controls (*see* Validation controls)

Visual Studio Properties, 1435

Web forms cars web site. *see* AspNetCarsSite website

Web server, 1386

Windows Communication

Foundation (WCF), 249, 555, 1583

address, 1032, 1037

API (*see* Application programming interface (API))

AutoLotService.cs., 1078

binding, 1032

characteristics, 1034

HTTP-Centric, 1035

MSMQ-Centric, 1036

TCP-Centric, 1036

client, 1031–1032

client-side proxy configuration, 1074

configuration settings

bindingConfiguration attribute, 1058

client proxy refreshment, 1061

default endpoints, 1055

MEX service behavior, 1059

multiple endpoints, 1056

contract, 1032–1033

distributed applications, 1028

features, 1026

hosting

base addresses specification, 1043

coding, 1043

configuration, 1042

definition, 1041

- metadata exchange (MEX), 1047
 - proxy files, Visual Studio, 1052
 - ServiceHost Type, 1045
 - service.serviceModel, 1047
 - svcutil.exe, 1050
 - TCP based binding, 1053
- MathService, 1073
- namespaces, 1029
- .NET assemblies, 1028
- Service assembly, 1031
- Service host, 1031
- service interfaces
 - [OperationContract] attribute, 1040
 - [ServiceContract] attribute, 1039
- Service Library project
 - MathServiceLibrary, 1063
 - SvcConfigEditor.exe, 1064
 - WcfTestClient.exe, 1064
- service-oriented architecture, 1027
- .svc file, 1079
- testing, 1080
- Visual Studio, 1030–1031
- web-centric service, 1076
- web.config file, 1079
- Windows service hosting
 - ABCs specification, 1067
 - installation, 1071
 - MathWindowsServiceHost, 1067
 - metadata exchange, 1069
 - Windows service installer, 1069
- Windows Forms database designer tools
 - completion, 914
 - generated App.config file, 909
 - strongly typed Data Adapter
 - examination, 913–914
 - strongly typed DataRow examination, 912
 - strongly typed DataSet examination, 909–910
 - strongly typed DataTable examination, 911
 - visual design
 - database selection, 905
 - data database model selection, 904
 - DataGridView editor, 903
 - data source type selection, 903
 - inventory table selection, 907
 - output, 908
 - saving connection string, 906
- Windows Forms GUI
 - DataView type, 885–887
 - deleting rows, 881–882
 - hydrating from generic List, 878–880
 - selecting rows, 882–884
 - updating rows, 885
- Windows Presentation Foundation (WPF), 1001
 - advantage, 1086
 - animation (*see* WPF Animation)
 - Application Class, 1095
 - Application.Windows collection, 1096
 - assemblies, 1093
 - ButtonTemplate, 1320
 - code-file approach, 1109
 - MainWindow Class, 1127
 - msbuild.exe, 1129
 - MyApp class, 1128
 - ContentPresenter, 1325
 - controls, 1087
 - default template, 1316
 - desired Functionalities, 1086
 - desktop applications, 1088
 - logical tree, 1314
 - namespaces, 1094
 - navigation applications, 1090
 - rendering model, 1087
 - Resource system (*see* WPF Resource system)
 - Silverlight, 1093
 - styles (*see* WPF Styles)
 - System.Windows.Controls.ContentControl, 1097
 - System.Windows.Controls.Control, 1098
 - System.Windows.DependencyObject, 1100
 - System.Windows.FrameworkElement, 1099
 - System.Windows.Media.Visual, 1100
 - System.Windows.Threading.
 - DispatcherObject, 1100
 - template bindings, 1324
 - template resource, 1321
 - 3D functionality, 1086
 - UI programming, 1088
 - visual cues, 1322
- Visual Studio
 - Button and Calendar control, 1134
 - Document Outline window, 1137
 - drag-and-drop operation, 1134
 - project templates, 1130
 - Properties window, 1134
 - Solution Explorer window, 1138
 - toolbox, 1133
 - Window designer, 1134
 - XAML editor (*see* XAML editor)
- visual tree, 1315
- Window class, 1096
- without XAML
 - AppExit() method, 1102
 - Application and Window classes, 1100
 - Application-Level Data, 1104
 - AppStartup() method, 1102
 - C# file, 1100
 - keyboard events, 1108
 - mouse events, 1107
 - Program class, 1101
 - simple user interface, 1103
 - Startup and Exit events, 1101

Windows Presentation Foundation (WPF) (*cont.*)

- StartupEventArgs, 1101
- StartupEventHandler delegate, 1101
- window closing event, 1105
- Window object, 1102

XAML

- Application Object, 1111
- Application XAML Markup, 1116
- attached properties, 1124
- BAML, 1115
- child element, 1122
- ClassModifier and FieldModifier
 - keywords, 1122
- compile-time process, 1117
- definition, 1109
- elements, 1122
- implementation logic, 1109
- Kaxaml, 1118
- Keywords, 1121
- layout managers, 1122
- markup extensions, 1125
- markup/procedural code, 1109
- msbuild.exe, 1112, 1114
- property-element syntax, 1123
- type converter *classes*, 1123
- Window Object, 1110
- Window XAML Markup, 1114
- XAML-based grammar, 1087
- XML namespaces, 1119, 1121
- x:Name and x:Class, 1122

XBAP applications, 1091

Windows process

- threads, role of, 624
- unique process identifier, 623

WithCancellation() extension method, 740

WPF. *see* Windows Presentation Foundation (WPF)

WPF Animation

- AutoReverse property, 1300
- By property, 1297
- C# Code, 1298
- class types, 1296
- definition, 1296
- Duration property, 1300
- From property, 1297
- RepeatBehavior property, 1301
- Timeline Base Class, 1298
- To property, 1297

WPF commands

- CanExecute event handlers, 1181
- CanHelpExecute() method, 1179
- CommandBindings, 1179–1180
- custom help system, 1180
- Intrinsic Command Objects, 1176
- Open command, 1180

properties, 1177

Save command, 1180

WPF controls, 1148

commands (*see* WPF commands)

content positioning

- Canvas panels, 1155
- DockPanel, 1163
- Grid panel, 1161
- Grid splitters, 1162
- ScrollViewer class, 1164
- StackPanel, 1158
- WrapPanel, 1158

data binding

- CheckBox control, 1208
- DataContext property, 1213
- DataGrid control, 1215
- DataGrid objects, 1208
- initial layout, 1209
- IValueConverter interface, 1213
- Label, 1208
- SetBindings() function, 1215
- Visual Studio, 1209

documentation, 1149

document controls, 1148

Documents tab

- AnnotationService class, 1206
- document reader control, 1205
- FlowDocument, 1203, 1207
- Sticky notes!, 1207
- TabItem control, 1202

Ink API Tab

- ComboBox control, 1198
- handling events, 1194
- InkCanvas control, 1195
- layout manager, 1189
- RadioButton controls, 1193
- save/load/clear data, 1200
- ToolBar control, 1190

Ink controls, 1148

OpenFileDialog box, 1149

Panel Controls, 1154

routed events (*see* WPF Routed events)

SaveFileDialog box, 1149

TabControl, 1186

Visual Studio, 1150

- Button control, 1151
- ContentControl, 1151
- data binding, 1209
- Document Outline window, 1152
- panel configuration, 1164

WPF dependency properties

- benefits, 1217
- CLR wrapper, 1221
- custom control, 1218

- CurrentNumber property, [1224](#)
 - data validation, [1225](#)
 - .NET property, [1223](#)
 - property change, [1226](#)
 - UserControl, [1222](#)
- definition, [1217](#)
- Height property, [1218](#)
- implementation, [1217](#)
- SetBinding() method, [1218](#)
- WPF Documents API
 - block elements, [1201](#)
 - inline elements, [1201](#)
 - XPS Control Layout Managers, [1202](#)
- WPF Resource system
 - binary resources
 - BinaryResourcesApp, [1277](#)
 - embedded resources, [1283](#)
 - image loading, [1282](#)
 - loose resources, [1279](#)
 - simple picture viewer, [1284](#)
 - logical resources
 - application-level resources, [1292](#)
 - DynamicResource, [1289](#)
 - merged resource
 - dictionary, [1292](#)
 - MyBrushes.xaml file, [1295](#)
 - ObjectResourcesApp, [1295](#)
 - resource-only library, [1294](#)
 - Resources property, [1285](#)
 - StaticResource, [1289](#)
 - window-wide resources, [1285](#)
- WPF routed events
 - bubbling events, [1183](#)
 - tunneling events, [1184](#)
- WPF styles
 - animated styles, [1310](#)
 - App.xaml file, [1305](#)
 - BasedOn property, [1305](#), [1308](#)
 - DynamicResource, [1305](#)
 - multiple triggers, [1309](#)

- override settings, [1306](#)
 - StaticResource, [1305](#)
 - style assignment, [1310](#)
 - TargetType, [1305](#), [1307](#)
 - templates, [1325](#)
 - Triggers, [1305](#), [1308](#)
- WPF window
 - menu system, [1170](#)
 - MouseEnter handler, [1174](#)
 - MouseExit handler, [1174](#)
 - MouseLeave handler, [1174](#)
 - nested panels, [1169](#)
 - spell checker, [1175](#)
 - StatusBar, [1173](#)
 - ToolBar, [1172](#)
 - UI design, [1173](#)

■ X, Y, Z

- Xamarin Studio, [53](#)
- XamlAnimations
 - discrete key frame, [1303](#)
 - event triggers, [1303](#)
 - GrowLabelFont.xaml file, [1302](#)
 - storyboards, [1302](#)
- XAML editor
 - application testing, [1144](#)
 - Button's Click event, [1143](#)
 - Closed event, [1144](#)
 - events handling, [1137](#)
 - GUI designing, [1140](#)
 - Loaded event, [1142](#)
 - WPF documentation, [1146](#)
- XML-based grammar (XAML), [1001](#)
- XML Paper Specification (XPS), [1201](#)
- XmlSerializer type, [780–781](#)
 - System.Xml.Serialization namespace, [789](#)
 - System.Xml.Serialization.XmlSerializer, [787](#)
- XML attributes, [789](#)
- XML file, [788](#)