

# Chapter 2

## Distribution Systems, Substations, and Integration of Distributed Generation

John D. McDonald, Bartosz Wojszczyk, Byron Flynn, and Ilia Voloh

### Glossary

Demand response	Allows the management of customer consumption of electricity in response to supply conditions.
Distributed generation	Electric energy that is distributed to the grid from many decentralized locations, such as from wind farms and solar panel installations.
Distribution grid	The part of the grid dedicated to delivering electric energy directly to residential, commercial, and industrial electricity customers.
Distribution management system	A smart grid automation technology that provides real time about the distribution network and allows utilities to remotely control devices in the grid.
Distribution substation	Delivers electric energy to the distribution grid.
Distribution system	The link from the distribution substation to the customer.

---

This chapter was originally published as part of the Encyclopedia of Sustainability Science and Technology edited by Robert A. Meyers. DOI:[10.1007/978-1-4419-0851-3](https://doi.org/10.1007/978-1-4419-0851-3)

J.D. McDonald (✉)

GE Energy, Digital Energy, 4200 Wildwood Parkway, Atlanta, GA 30339, USA

e-mail: [j.d.mcdonald@ieee.org](mailto:j.d.mcdonald@ieee.org); [johnd.mcdonald@ge.com](mailto:johnd.mcdonald@ge.com)

B. Wojszczyk • B. Flynn • I. Voloh

GE Energy, Digital Energy, 20 Technology Parkway, Suite 380, Norcross,

GA 30092-2929, USA

e-mail: [Bartosz.Wojszczyk@ge.com](mailto:Bartosz.Wojszczyk@ge.com); [byron.flynn@ge.com](mailto:byron.flynn@ge.com)

M.M. Begovic (ed.), *Electrical Transmission Systems and Smart Grids:*

*Selected Entries from the Encyclopedia of Sustainability Science and Technology,*

DOI 10.1007/978-1-4614-5830-2\_2, © Springer Science+Business Media New York 2013

Renewable energy	Energy from natural resources such as sunlight, wind, rain, tides, biofuels, and geothermal heat, which are naturally replenished.
Smart grid	A modernization of the electricity delivery system so it monitors, protects, and automatically optimizes the operation of its interconnected elements.

## Definition of the Subject

This entry describes the major components of the electricity distribution system – the distribution network, substations, and associated electrical equipment and controls – and how incorporating automated distribution management systems, devices, and controls into the system can create a “smart grid” capable of handling the integration of large amounts of distributed (decentralized) generation of sustainable, renewable energy sources.

## Introduction

Distributed generation (DG) or decentralized generation is not a new industry concept. In 1882, Thomas Edison built his first commercial electric plant – “Pearl Street.” The Pearl Street station provided 110 V direct current (DC) electric power to 59 customers in lower Manhattan. By 1887, there were 121 Edison power stations in the United States delivering DC electricity to customers. These early power plants ran on coal or water. Centralized power generation became possible when it was recognized that alternating current (AC) electricity could be transported at relatively low costs with reduced power losses across great distances by taking advantage of the ability to raise the voltage at the generation station and lower the voltage near customer loads. In addition, the concepts of improved system performance (system stability) and more effective generation asset utilization provided a platform for wide-area grid integration. Recently, there has been a rapidly growing interest in wide deployment of distributed generation, which is electricity distributed to the grid from a variety of decentralized locations. Commercially available technologies for distributed generation are based on wind turbines, combustion engines, micro- and mini-gas turbines, fuel cells, photovoltaic (solar) installations, low-head hydro units, and geothermal systems.

Deregulation of the electric utility industry, environmental concerns associated with traditional fossil fuel generation power plants, volatility of electric energy costs, federal and state regulatory support of “green” energy, and rapid technological developments all support the proliferation of distributed generation in electric utility systems. The growing rate of DG deployment also suggests that alternative energy-based solutions will play an increasingly important role in the smart grid and modern utility.

Large-scale implementation of distributed generation can lead to the evolution of the distribution network from a “passive” (local/limited automation, monitoring, and control) system to an “active” (global/integrated, self-monitoring, semiautomated) system that automatically responds to the various dynamics of the electric grid, resulting in higher efficiency, better load management, and fewer outages. However, distributed generation also poses a challenge for the design, operation, and management of the power grid because the network no longer behaves as it once did. Consequently, the planning and operation of new systems must be approached differently, with a greater amount of attention paid to the challenges of an automated global system.

This entry describes the major components and interconnected workings of the electricity distribution system, and addresses the impact of large-scale deployment of distributed generation on grid design, reliability, performance, and operation. It also describes the distributed generation technology landscape, associated engineering and design challenges, and a vision of the modern utility.

## Distribution Systems

Distribution systems serve as the link from the distribution substation to the customer. This system provides the safe and reliable transfer of electric energy to various customers throughout the service territory. Typical distribution systems begin as the medium-voltage three-phase circuit, typically about 30–60 kV, and terminate at a lower secondary three- or single-phase voltage typically below 1 kV at the customer’s premise, usually at the meter.

Distribution feeder circuits usually consist of overhead and underground circuits in a mix of branching laterals from the station to the various customers. The circuit is designed around various requirements such as required peak load, voltage, distance to customers, and other local conditions such as terrain, visual regulations, or customer requirements. These various branching laterals can be operated in a radial configuration or as a looped configuration, where two or more parts of the feeder are connected together usually through a normally open distribution switch. High-density urban areas are often connected in a complex distribution underground network providing a highly redundant and reliable means connecting to customers. Most three-phase systems are for larger loads such as commercial or industrial customers. The three-phase systems are often drawn as one line as shown in the following distribution circuit drawing (Fig. 2.1) of three different types of circuits.

The secondary voltage in North America and parts of Latin America consists of a split single-phase service that provides the customer with 240 and 120 V, which the customer then connects to devices depending on their ratings. This is served from a three-phase distribution feeder normally connected in a Y configuration consisting of a neutral center conductor and a conductor for each phase, typically assigned a letter A, B, or C.

Single-phase customers are then connected by a small neighborhood distribution transformer connected from one of the phases to neutral, reducing the voltage from

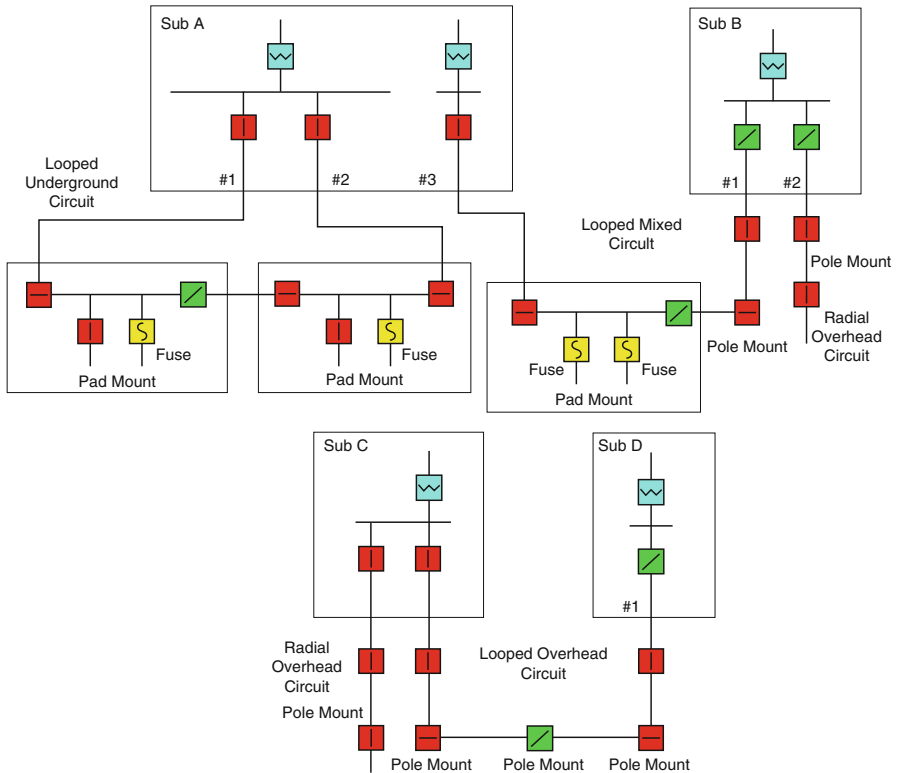

**Fig. 2.1** Simple distribution system single line drawings

the primary feeder voltage to the secondary split service voltage. In North America, normally 10 or fewer customers are connected to a distribution transformer.

In most other parts of the world, the single-phase voltage of 220 or 230 V is provided directly from a larger neighborhood distribution transformer. This provides a secondary voltage circuit often serving hundreds of customers.

Figure 2.1 shows various substations and several feeders serving customers from those substations. In Fig. 2.1, the primary transformers are shown as blue boxes in the substation, various switches, breakers, or reclosers are shown as red (closed) or green (open) shapes, and fuses are shown as yellow boxes.

## ***Distribution Devices***

There are several distribution devices used to improve the safety, reliability, and power quality of the system. This section will review a few of those types of devices.

**Fig. 2.2** Distribution pad-mount switch



**Fig. 2.3** Distribution pole-mounted reclosing relay



**Switches:** Distribution switches (Fig. 2.2) are used to disconnect various parts of the system from the feeder. These switches are manually, remotely, or automatically operated. Typically, switches are designed to break load current but not fault current and are used in underground circuits or tie switches.

**Breakers:** Like switches, distribution breakers are used to disconnect portions of the feeder. However, breakers have the ability to interrupt fault current. Typically, these are tied to a protective relay, which detects the fault conditions and issues the open command to the breaker.

**Reclosers:** These are a special type of breaker (Fig. 2.3), typically deployed only on overhead and are designed to reduce the outage times caused by momentary faults. These types of faults are caused by vegetation or temporary short circuits. During the reclose operation, the relay detects the fault, opens the switch, waits a few seconds, and issues a close. Many overhead distribution faults are successfully cleared and service is restored with this technique, significantly reducing outage times.

**Fig. 2.4** Distribution overhead 600 kVA capacitor

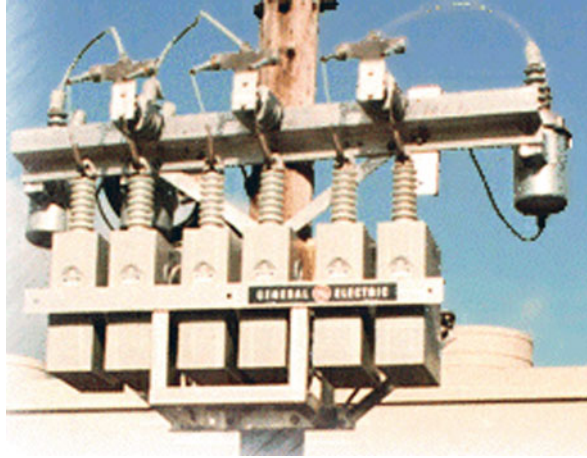

Capacitors: These are three-phase capacitors designed to inject volt amp reactives (VARs) into the distribution circuit, typically to help improve power factor or support system voltage (Fig. 2.4). They are operated in parallel with the feeder circuit and are controlled by a capacitor controller. These controllers are often connected to remote communications allowing for automatic or coordinated operation.

Fuses: These are standard devices used to protect portions of the circuit when a breaker is too expensive or too large. Fuses can be used to protect single-phase laterals off the feeder or to protect three-phase underground circuits.

Lightning arresters: These devices are designed to reduce the surge on the line when lightning strikes the circuit.

### ***Automation Scheme: FDIR***

The following description highlights an actual utility's FDIR automation scheme, their device decisions, functionality and system performance. Automation sequences include fault detection, localization, isolation, and load restoration (FDIR). These sequences will detect a fault, localize it to a segment of feeder, open the switches around the fault, and restore un-faulted sources via the substation and alternative sources as available. These algorithms work to safely minimize the fault duration and extent, significantly improving the SAIDI (system average interruption duration index) and SAIFI (system average interruption frequency Index) performance metric for the customers on those feeders. An additional important sequence is the automatic check of equipment loading and thermal limits to determine whether load transfers can safely take place.

Modern systems communicate using a secure broadband Ethernet radio system, which provides significant improvement over a serial system, including supporting peer-to-peer communications, multiple access to tie switches, and remote access by

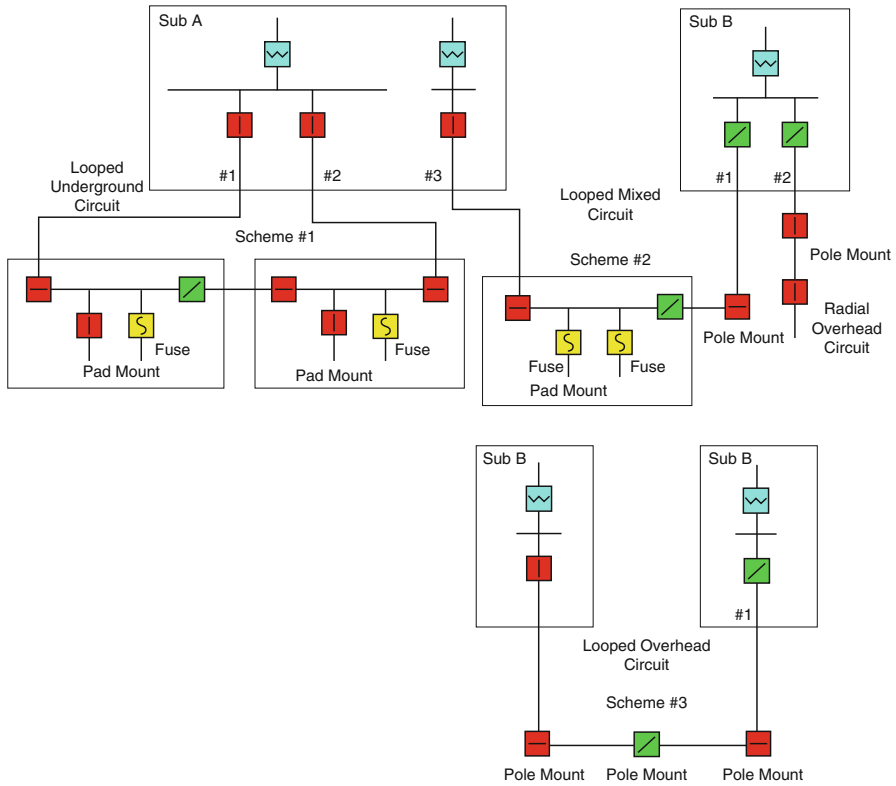

Fig. 2.5 Distribution automation (DA) system single lines

communications and automation maintenance personnel. The communication system utilizes an internet protocol (IP)–based communication system with included security routines designed to meet the latest NERC (North American Electric Reliability Corporation) or the distribution grid operator’s requirements.

Feeder circuits to be automated are typically selected because they have relatively high SAIDI indices serving high-profile commercial sites. Scheme 1 utilized two pad-mount switches connected to one substation. Scheme 2 consisted of a mix of overhead and underground with vault switchgear and a pole-mounted recloser. Scheme 3 was installed on overhead circuits with three pole-mounted reclosers.

Automation Schemes 1, 2 and 3 (Fig. 2.5) were designed to sense distribution faults, isolate the appropriate faulted line sections, and restore un-faulted circuit sections as available alternate source capacity permitted.

**Safety**

Safety is a critical piece of system operation. Each algorithm has several safety checks before any operation occurs. Before the scheme logic is initialized, a series of checks occur, including:

- Auto Restoration is enabled on a specific scheme – dispatchers do this via the distribution management system or SCADA system.
- Auto Restoration has not been disabled by a crew in the field via enable/disable switches at each device location.
- Auto Restoration has been reset – each scheme must be reset by the dispatcher after DA has operated and system has been restored to normal configuration.
- Communications Status – verifies that all necessary devices are on-line and communicating.
- Switch Position – verifies that each appropriate line switch is in the appropriate position (see Fig. 2.1).
- Voltages – checks that the appropriate buses/feeders are energized.
- Feeder Breaker Position – verifies the faulted feeder breaker has locked open and was opened only by a relay, not by SCADA or by the breaker control handle.

Prior to closing the tie switch and restoring customers in un-faulted sections, the following safety checks occur:

- Determine Pre-Fault Load – determine pre-fault load on un-faulted section of line.
- Compare Pre-Fault Load to Capacity – determine if alternate source can handle the un-faulted line section load.

After any DA algorithm executes:

- Notifies Dispatch of Status of DA System – success or failure of restoring load in un-faulted line sections.
- Reset is Necessary – algorithm is disabled until reset by dispatcher once the fault is repaired and the system is put back to normal configuration (see Fig. 2.1).

In summary, automation can occur *only* if these five conditions are true for every device on a scheme:

- Enable/Disable Switch is in enable position
- Local/Remote switch is in remote
- Breaker “hot-line” tag is off.
- Breaker opens from a relay trip and stays open for several seconds (that is, goes to lockout).
- Dispatch has reset the scheme(s) after the last automation activity.

Each pad-mounted or pole-mounted switch has a local enable/disable switch as shown in Fig. 2.6. Journeymen are to use these switches as the primary means of disabling a DA scheme before starting work on any of the six automated circuits or circuit breakers or any of the seven automated line switches.

## FDIR System Components

The automation system consists of controllers located in pad-mount switches, pole-mounted recloser controls (Fig. 2.7), and in substations (Fig. 2.8).





Fig. 2.6 Pad-mount controller and pole-mount reclosing relay with enable/disable switches



Fig. 2.7 Typical pad-mount and pole-mount switches



Fig. 2.8 Typical substation controller and vault switch

## **Pad-Mounted Controller**

The pad-mounted controller was selected according to the following criteria:

- Similar to existing substation controllers – simplifying configuration and overall compatibility
- Compatible with existing communications architecture
- Uses IEC 61131-3 programming
- Fault detection on multiple circuits
- Ethernet connection
- Supports multiple master stations
- Installed cost

The pad-mounted controller (Fig. 2.7) selected was an Ethernet-based controller that supported the necessary above requirements. The IEC 61131-3 programming languages include:

- Sequential Function Chart – describes operations of a sequential process using a simple graphical representation for the different steps of the process, and conditions that enable the change of active steps. It is considered to be the core of the controller configuration language, with other languages used to define the steps within the flowchart.
- Flowchart – a decision diagram composed of actions and tests programmed in structured text, instruction list, or ladder diagram languages. This is a proposed IEC 61131-3 language.
- Function Block Diagram – a graphic representation of many different types of equations. Rectangular boxes represent operators, with inputs on the left side of the box and outputs on the right. Custom function blocks may be created as well. Ladder diagram expressions may be a part of a function block program.
- Ladder Diagram – commonly referred to as “quick LD,” the LD language provides a graphic representation of Boolean expressions. Function blocks can be inserted into LD programs.
- Structured Text – high-level structured language designed for expressing complex automation processes which cannot be easily expressed with graphic languages. Contains many expressions common to software programming languages (CASE, IF-THEN-ELSE, etc.). It is the default language for describing sequential function chart steps.
- Instruction List – a low-level instruction language analogous to assembly code.

## **Pole-Mounted Controller with Recloser**

The recloser controller was selected according to the following criteria:

- Similar requirements to pad-mounted controllers
- Control must provide needed analog and status outputs to DA remote terminal units (RTU)

## **Substation Controller**

The substation controller (Fig. 2.8) was selected per the following criteria:

- Similar to field controllers – simplifying configuration and overall compatibility
- Compatible with communications architecture
- Uses IEC 61131-3
- Ethernet and serial connections
- Supports multiple master stations including master station protocols
- Remote configuration is supported

## ***Communications System***

### **General**

The primary requirement of the communications system was to provide a secure channel between the various switches and the substation. The communication channel also needed to allow remote connection to the switchgear intelligent electronic devices (IEDs) for engineers and maintenance personnel. Additionally, the DA system also required the support for multiple substation devices to poll the controller at the tie switch. These requirements indicated the need for multi-channel or broadband radio.

### **Radio Communication Selection Criteria**

Primary considerations for selecting radio communications include:

- Security
- Supports remote configuration
- Broadband or multiple channels
- Compatible with multiple protocols
- From a major supplier
- Installed cost

The radio selected is a broadband radio operating over 900 MHz spread spectrum and 512 kbps of bandwidth. The wide-area network (WAN), Ethernet-based radio, supports the necessary protocols and provides multiple communications channels.

The communications network operates as a WAN providing the capability to communicate between any two points simply by plugging into the 10baseT communications port. A DA maintenance master was installed to communicate with the various controllers and to provide a detailed view of the DA system from the dispatch center. The DA system was also connected to the dispatch master

station, which gives the dispatcher the ability to monitor and control the various DA algorithms and, in the future, typical SCADA control of the switches using distribution network protocol (DNP). (Since the dispatch master station currently does not support DNP over IP, a serial to Ethernet converter will be installed at the dispatch center to handle the conversion). Figure 2.9 illustrates the communications architecture.

The radios communicate using point to multi-point with an access point radio operating as the base station radio and two types of remote radios, with serial or Ethernet. Some of the remote controllers only used DNP serial channels, requiring the radios to convert the serial connection to Ethernet. The remote Ethernet-based devices connect to the radios using a standard 10BaseT connection. Refer to Fig. 2.9.

For sites that require multiple DNP masters to connect to the serial controllers, the radios and the controllers have two serial connections. A new feature of the serial controllers is the support of point-to-point protocol (PPP). PPP provides a method for transmitting datagrams over serial point-to-point links. PPP contains three main components:

- A method for encapsulating datagrams over serial links. PPP uses the high-level data link control (HDLC) protocol as a basis for encapsulating datagrams over point-to-point links.
- An extensible Link Control Protocol (LCP) which is used to establish, configure, maintain, terminate, and test the data link connection.
- A family of network control protocols (NCP) for establishing and configuring different network layer protocols after LCP has established a connection. PPP is designed to allow the simultaneous use of multiple network layer protocols.

Establishing a PPP connection provides support for DNP multiple masters and a remote connection for maintenance over one serial communication line, effectively providing full Ethernet functionality over a single serial channel.

## **Security**

The wireless system contains several security features. Table 2.1 outlines the threat and the security measures implemented in the radio to meet these threats.

## ***Automation Functionality***

### **Distribution Automation Schemes**

Distribution automation (DA) scheme operation is discussed in this section. All three schemes are configured the same, differing only in the type of midpoint and tie point switches used and whether the two sources are in the same or different

Radio Communications  
Consists of a Distribution Automation  
Wide Area Network

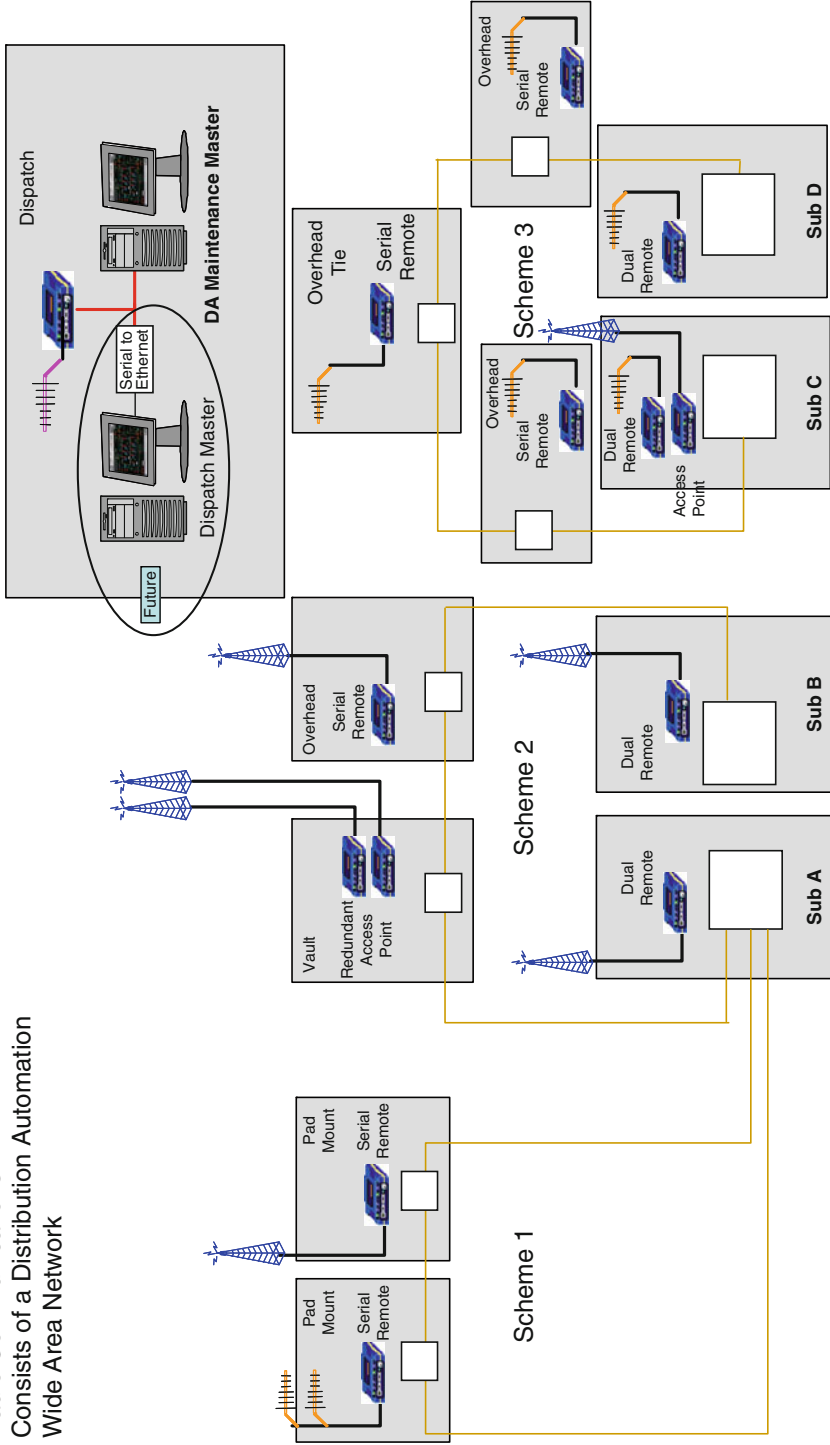

Fig. 2.9 DA communications infrastructure

**Table 2.1** Security risk management

Security threat	900 MHz radio security
Unauthorized access to the backbone network through a foreign remote radio	Approved remotes list. Only those remotes included in the AP list will connect
“Rogue” AP, where a foreign AP takes control of some or all remote radios and thus remote devices	Approved AP List. A remote will only associate to those AP included in its local
Dictionary attacks, where a hacker runs a program that sequentially tries to break a password	Failed-login lockdown. After three tries, the transceiver ignores login requests for 5 min. Critical event reports (traps) are generated as well
Denial of service, where Remote radios could be reconfigured with bad parameters bringing the network down	<ul style="list-style-type: none"> <li>• Remote login</li> <li>• Local console login</li> <li>• Disabled HTTP and Telnet to allow only local management services</li> </ul>
Airwave searching and other hackers in parking lots, etc.	<ul style="list-style-type: none"> <li>• 900 MHz FHSS does not talk over the air with standard 802.11b cards.</li> <li>• The transceiver cannot be put in a promiscuous mode.</li> <li>• Proprietary data framing</li> </ul>
Eavesdropping, intercepting messages	128-bit encryption
Key cracking	Automatic rotating key algorithm
Replaying messages	128-bit encryption with rotating keys
Unprotected access to configuration via SNMPv1	Implement SNMPv3 secure operation
Intrusion detection	Provides early warning via SNMP through critical event reports (unauthorized, logging attempts, etc.)

substations. All three are set up as two-zone circuit pairs, with one tie point and two midpoints. Only one scheme will be shown (Fig. 2.10), as the others are analogous. Scheme 1 operates on the system shown in Fig. 2.10. It consists of two pad-mount switches and one substation. The pad-mount controllers communicate with the controller in the substation and the substation controller communicates with the DA maintenance master station and, in the future, the dispatch master.

**Zone 1 Permanent Fault**

Before the algorithm operates, the safety checks occur as previously described. Refer to Figs. 2.11 and 2.12. If a permanent Zone 1 fault occurs (between switch 1 and substation CB14) and the algorithm is enabled and the logic has been initialized, the following actions occur:

1. After relaying locks out the substation breaker, the algorithm communicates with the field devices and the station protection relays to localize the fault.
2. Algorithm determines fault is between the substation and SW1.

Zone 1 Permanent Fault

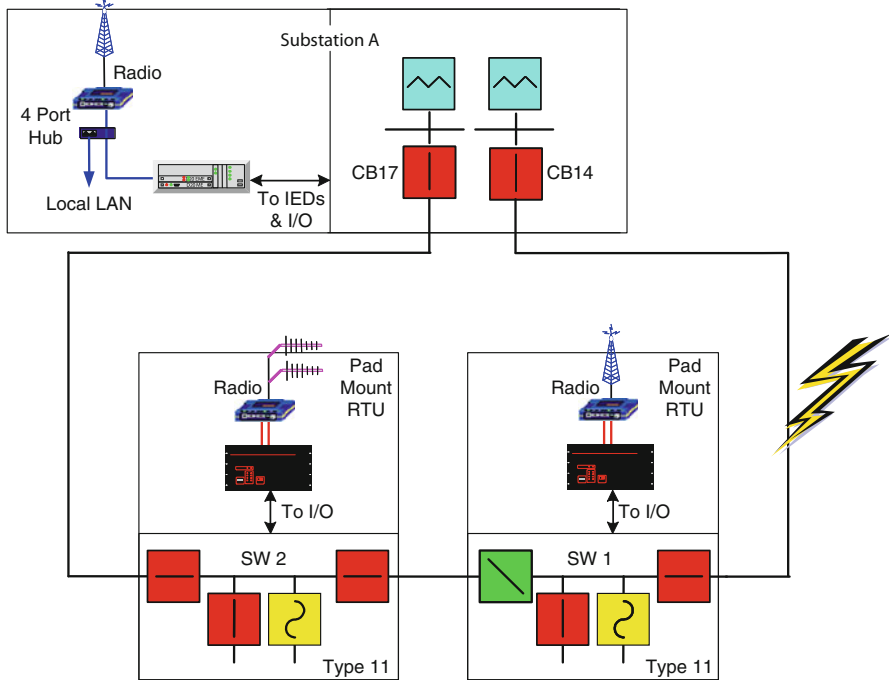

Fig. 2.10 Scheme 1 architecture

3. Algorithm opens the circuit at SW1 connected to the incoming line from the substation, isolating the fault.
4. Algorithm gathers pre-fault load of section downstream of SW1 from the field devices.
5. Algorithm determines if capacity exists on alternate source and alternate feeder.
6. If so, algorithm closes the tie switch and backfeeds load, restoring customers on un-faulted line.
7. Reports successful operation to dispatch. The system is now as shown in Figs. 2.11 and 2.12, resulting in a reduction of SAIFI and SAIDI.

**Zone 1 Permanent Fault: Load Too High to Safely Transfer**

In this case, a Zone 1 permanent fault occurs as shown in Fig. 2.13 and the previous example, except that this time loads are too high for the alternate source to accept load from the faulted feeder. Note the dispatch DA screens are descriptive and present information in plain language. Refer to Figs. 2.13 and 2.14.

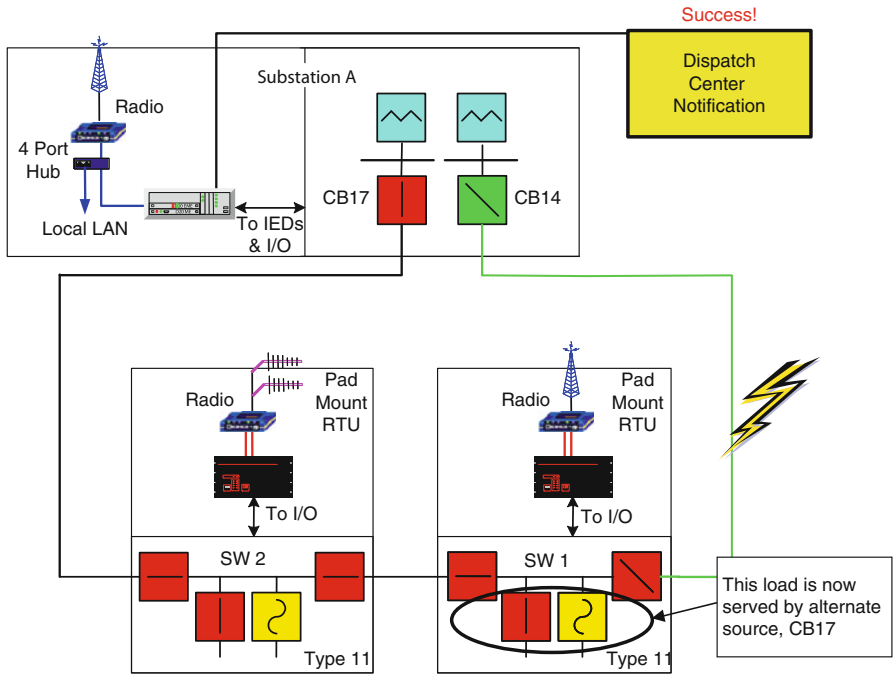

Fig. 2.11 Scheme 1 architecture after successful DA operation

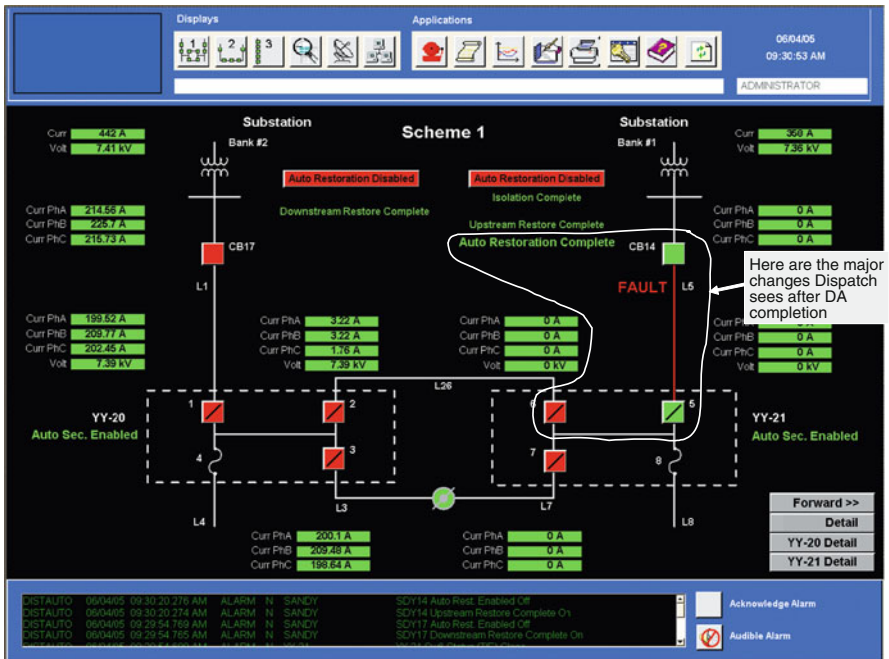

Fig. 2.12 Dispatch notification of scheme 1 isolation/restoration success



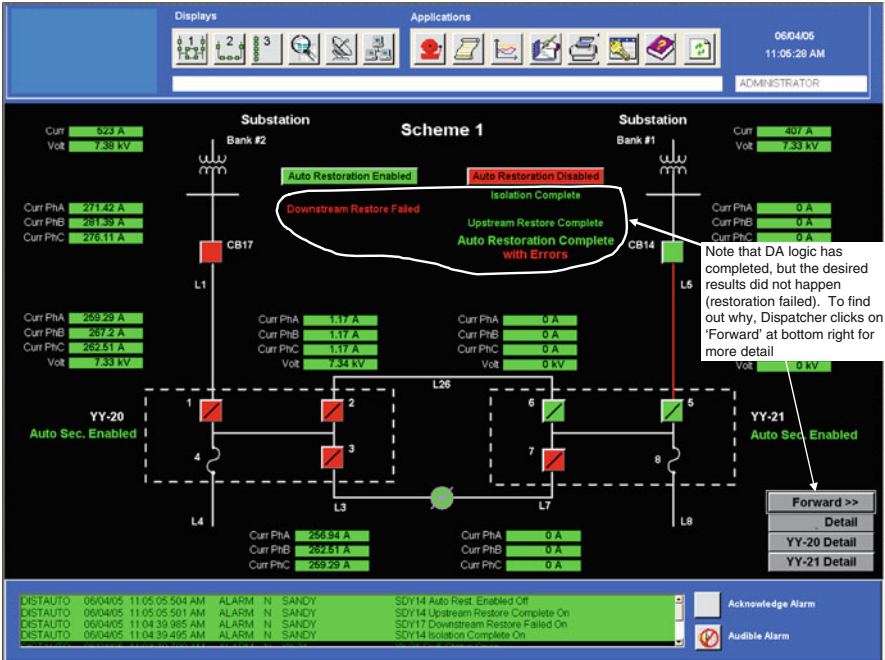

Fig. 2.13 Dispatch notification of scheme 1 restoration failure

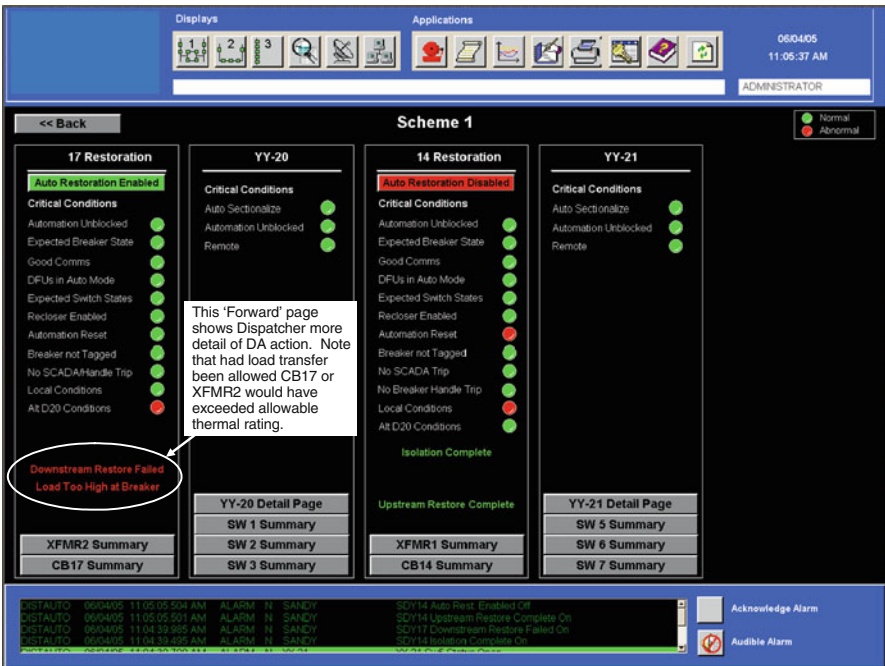

Fig. 2.14 Dispatch detail of scheme 1 restoration failure

### Zone 2 Permanent Fault

Depending on the type of the SW1 device (Fig. 2.15), the following actions occur:

If SW1 is a recloser (as in Schemes 2 and 3):

1. SW1 locks out in three shots. If SW1 is a pad-mount switch with no protection package (as in Scheme 1), the substation breaker goes to lockout. Fifty percent of CB11 customers remain in power.
2. This action occurs whether DA is enabled or disabled. That is, *existing circuit protection is unaffected by any DA scheme or logic.*
3. Safety checks are performed to ensure DA can safely proceed.
4. DA logic sees loss of voltage only beyond SW1 (recloser at lockout) and saw fault current through CB11 and SW1, so it recognizes that the line beyond SW1 is permanently faulted.
5. DA will not close into a faulted line, so the alternate source tie point (open point of SW2) remains open.
6. Customers between SW1 and SW2 lose power (about 50% of CB11 customers).

If SW1 is switchgear (as in Scheme 1):

1. Substation circuit breaker, CB11, locks out in three shots.
2. This action occurs whether DA is enabled or disabled. That is, *existing circuit protection is unaffected by any DA scheme or logic.*
3. Safety checks are performed to ensure DA can safely proceed.

### Zone 2 Permanent Fault

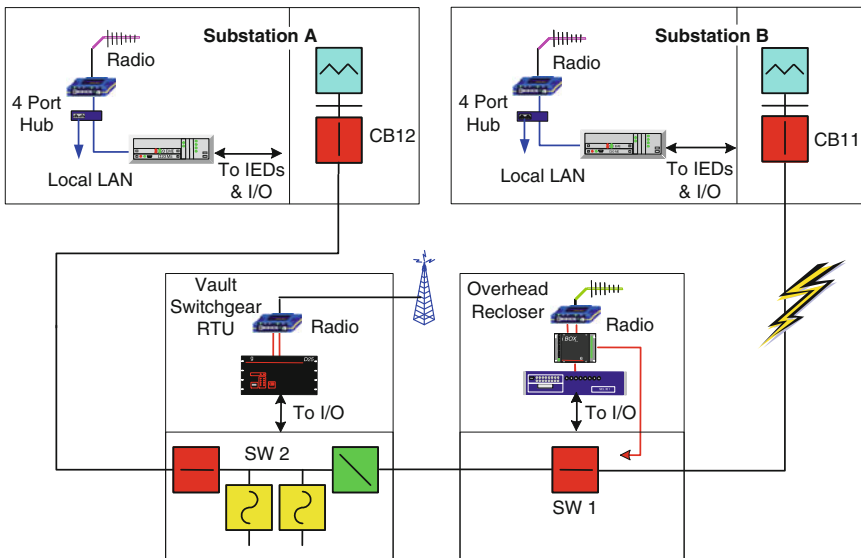

Fig. 2.15 Scheme 2 architecture

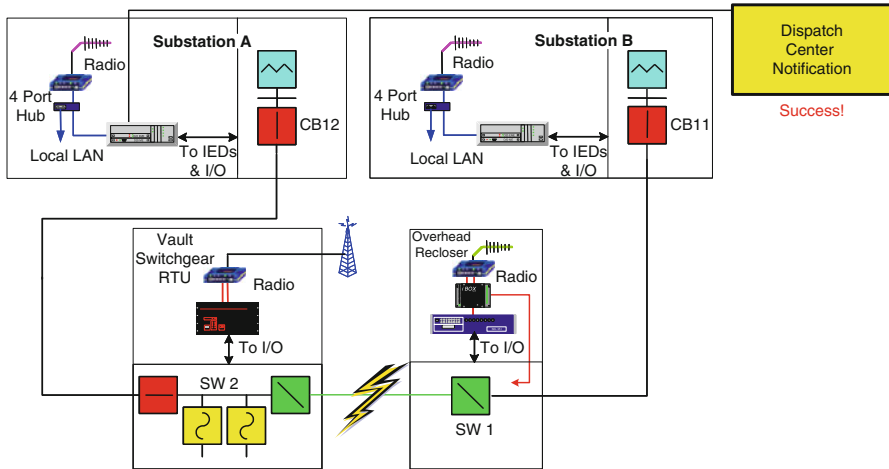

Fig. 2.16 Scheme 2 architecture after successful DA operation

4. DA logic sees loss of voltage beyond CB11 (CB at lockout) and saw fault current through CB11 and SW1, so it recognizes that the line beyond (not before) SW1 is permanently faulted.
5. Fault is isolated by DA logic, sending open command to SW1.
6. DA logic recognizes line upstream of SW1 is good (fault current sensed at two devices), and closes CB11, heating up line to source side of open SW1. Power is now restored to 50% of customers.
7. DA will not close into a faulted line, so the alternate source tie point (open point of SW2) remains open (Figs. 2.16 and 2.17).

**System Operation**

In 5 months of operation thus far the DA system has operated for 21 faults; all were Zone 2 faults on Scheme 3 (all downstream of the midpoint SW1). Three of those faults were permanent and took the line recloser SW1 to lockout. As a result, in 5 months, the DA pilot has saved 550 customers 6 h of power outage time (i.e., saved 3,300 customer hours lost) and eliminated 18 momentaries for those same 550 customers.

There have been no Zone 1 faults on any scheme; therefore, no load transfers to alternate sources have taken place.

**Automation Scheme: Volt/VAR Control (VVC)**

**General**

The various loads along distribution feeders result in resistive ( $I^2R$ ) and reactive ( $I^2X$ ) losses in the distribution system. If these losses are left uncompensated, an

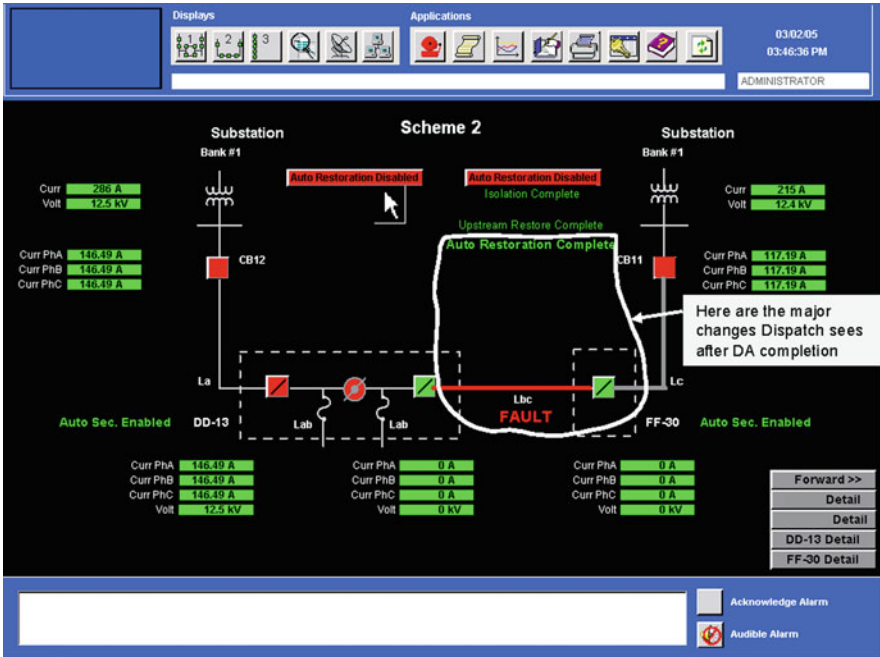

Fig. 2.17 Dispatch notification of scheme 2 isolation/restoration success

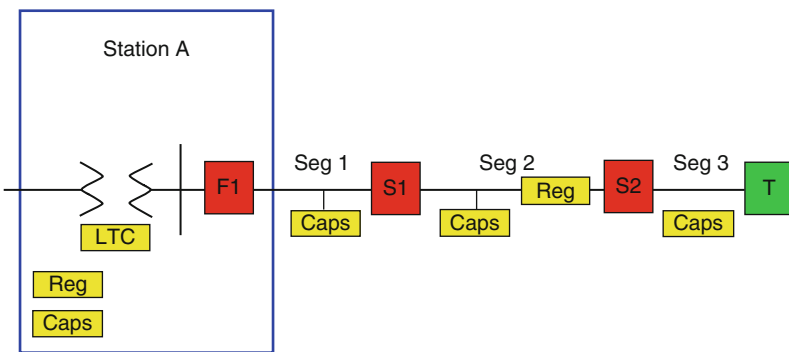

Fig. 2.18 Example station and feeder voltage/VAR control devices

additional problem of declining voltage profile along the feeder will result. The most common solution to these voltage problems is to deploy voltage regulators at the station or along the feeder and/or a transformer LTC (load tap changers) on the primary station transformer; additional capacitors at the station and at various points on the feeder also provide voltage support and compensate the reactive loads. Refer to Fig. 2.18.



**Fig. 2.19** Example station and feeder voltage/VAR control devices

Many utilities are looking for additional benefits through improved voltage management. Voltage management can provide significant benefits through improved load management and improved voltage profile management.

The station Volt/VAR equipment consists of a primary transformer with either an LTC (Fig. 2.18) or a station voltage regulator and possibly station capacitors. The distribution feeders include line capacitors and possibly line voltage regulators.

The LTC is controlled by an automatic tap changer controller (ATC). The substation capacitors are controlled by a station capacitor controller (SCC), the distribution capacitors are controlled by an automatic capacitor controller (ACC), and the regulators are controlled by an automatic regulator controller (ARC). These controllers are designed to operate when local monitoring indicates a need for an operation including voltage and current sensing. Distribution capacitors are typically controlled by local power factor, load current, voltage, VAR flow, temperature, or the time (hour and day of week).

Some utilities have realized additional system benefits by adding communications to the substation, and many modern controllers support standard station communications protocols such as DNP.

This system (shown in Figs. 2.19 and 2.20) includes the ability to remotely monitor and manually control the volt/VAR resources, as well as the ability to provide integrated volt/VAR control (IVVC).

### **Benefits of Volt/VAR Control (VVC)**

The VAR control systems can benefit from improved power factor and the ability to detect a blown fuse on the distribution capacitor. Studies and actual field data have indicated that systems often add an average of about 1 MVAR to each feeder. This can result in about a 2% reduction in the losses on the feeder.

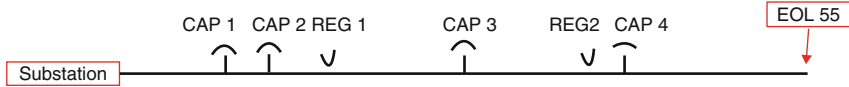

**Fig. 2.20** Three-phase station voltage regulator

Based on the assumptions, the benefits for line loss optimization that some utilities have calculated represent a significant cost-benefit payback. However, one of the challenges utilities face is that the cost and benefits are often disconnected. The utility's distribution business usually bears the costs for an IVVC system. The loss reduction benefits often initially flow to the transmission business and eventually to the ratepayer, since losses are covered in rates. Successful implementation of a loss reduction system will depend on helping align the costs with the benefits. Many utilities have successfully reconnected these costs and benefits of a Volt/VAR system through the rate process.

The voltage control systems can provide benefit from reduced cost of generation during peak times and improved capacity availability. This allows rate recovery to replace the loss of revenue created from voltage reduction when it is applied at times other than for capacity or economic reasons. The benefits for these programs will be highly dependent on the rate design, but could result in significant benefits.

There is an additional benefit from voltage reduction to the end consumer during off-peak times. Some utilities are approaching voltage reduction as a method to reduce load similar to a demand response (DR) program. Rate programs supporting DR applications are usually designed to allow the utility to recapture lost revenue resulting from a decreased load. In simplified terms, the consumer would pay the utility equal to the difference between their normal rate and the wholesale price of energy based on the amount of load reduction. Figure 2.21 highlights the impact of voltage as a load management tool.



Normal Operation = 7-23-10 @ 4:44pm  
 VVC Working properly = 7-24-10 @ 4:44pm

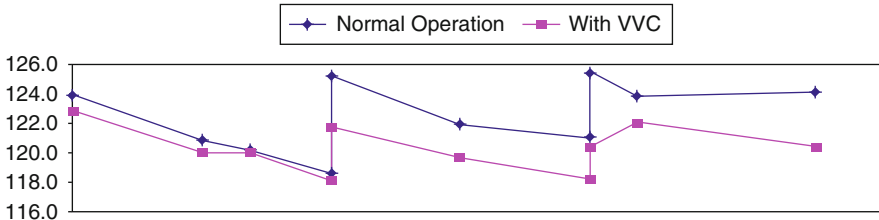
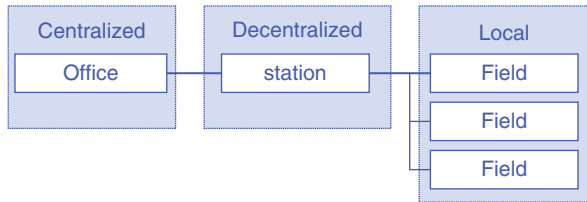

Fig. 2.21 Three-phase station voltage profile

Fig. 2.22 Relationship automation at centralized, decentralized, and local areas



This chart contains real data from a working feeder utilizing Volt/VAR control. As the chart indicates, with VVC, the feeder voltage profile is flatter and lower.

### Considerations

#### Centralized, Decentralized, or Local Algorithm

Given the increasing sophistication of various devices in the system, many utilities are facing a choice of location for the various algorithms (Fig. 2.22). Often it is driven by the unique characteristics of the devices installed or by the various alternatives provided by the automation equipment suppliers.

Table 2.2 compares the various schemes.

#### Safety and Work Processes

The safety of workers, of the general public, and of equipment must not be compromised. This imposes the biggest challenge for deploying any automatic or

**Table 2.2** Three-phase station voltage profile

Centralized	Decentralized	Local
Supports more complex applications such as: Load Flow, DTS, Study	Most station IEDs support automation	Local IEDs often include local algorithms
Support for full network model	Faster response than centralized DA	Usually initiated after prolonged comms outage, e.g., local capacitor controller
Optimizes improvements	Smaller incremental deployment costs	Operates faster than other algorithms usually for protection, reclosing, and initial sectionalizing
Dynamic system configuration	Often used for initial deployment because of the reduced complexity and costs	Usually only operates based on local sensing or peer communications
Automation during abnormal conditions	Typical applications: include: initial response, measure pre-event	Less sophisticated and less expensive
Enables integration with other sources of data – EMS, OMS, AMI, GIS	Flexible, targeted, or custom solution	Easiest to begin deploying
Integration with other processes planning, design, dispatch	Usually cheaper and easier for initial deploy	Hardest to scale sophisticated solutions
Easier to scale, maintain, upgrade, and backup	Hard to scale sophisticated solutions	

remotely controlled systems. New automation systems often require new work processes. Utility work process and personnel must be well trained to safely operate and maintain the new automated distribution grid systems.

Operating practices and procedures must be reviewed and modified as necessary to address the presence of automatic switchgear.

Safety related recommendations include:

- Requirement for “visible gap” for disconnect switches
- No automatic closures after 2 min have elapsed following the initial fault to protect line crews
- System disabled during maintenance (“live line”) work, typically locally and remotely

**The Law of Diminishing Returns**

Larger utilities serve a range of customer types across a range of geographic densities. Consequently, the voltage profile and the exposure to outages are very different from circuit to circuit. Most utilities analyze distribution circuits and deploy automation on the most troublesome feeders first. Figure 2.23 depicts this difference.



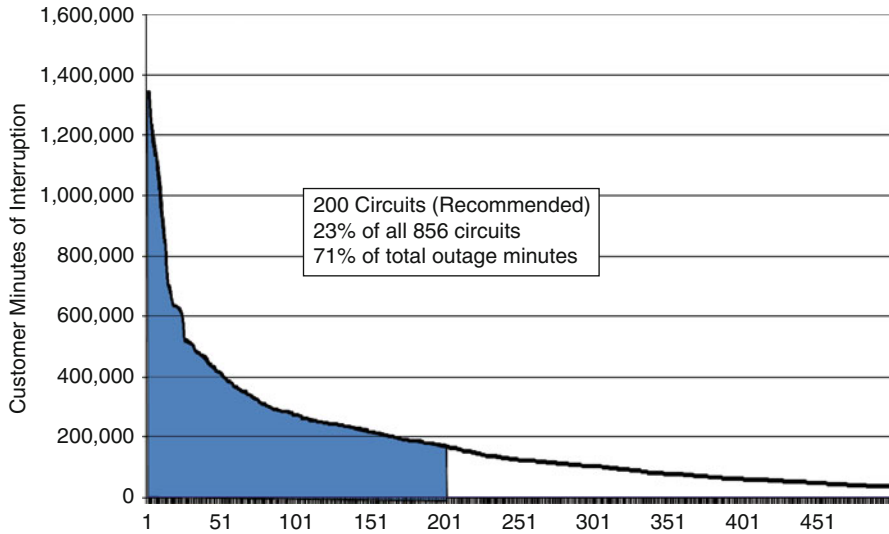

Fig. 2.23 Customer minutes interrupted by feeder

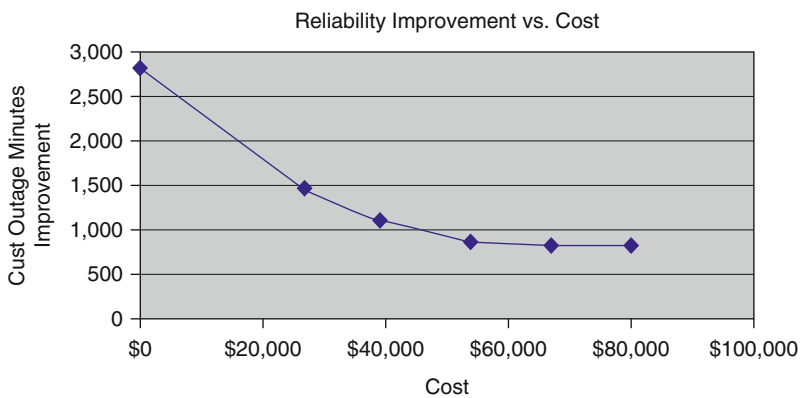

Fig. 2.24 Customer minutes interrupted by cost

Figure 2.23 highlights the decision by one utility to automate roughly 25% of feeders, which account for 70% of overall customer minutes interrupted.

The same analysis can be done on a circuit basis. The addition of each additional sensing and monitoring device to a feeder leads to a diminishing improvement to outage minutes as shown in Fig. 2.24.

Both of these elements are typically studied and modeled to determine the recommended amount of automation each utility is planning.

## Substations

### *Role and Types of Substations*

Substations are key parts of electrical generation, transmission, and distribution systems. Substations transform voltage from high to low or from low to high as necessary. Substations also dispatch electric power from generating stations to consumption centers. Electric power may flow through several substations between the generating plant and the consumer, and the voltage may be changed in several steps. Substations can be generally divided into three major types:

1. *Transmission substations* integrate the transmission lines into a network with multiple parallel interconnections so that power can flow freely over long distances from any generator to any consumer. This transmission grid is often called the bulk power system. Typically, transmission lines operate at voltages above 138 kV. Transmission substations often include transformation from one transmission voltage level to another.
2. *Sub-transmission substations* typically operate at 34.5 kV through 138 kV voltage levels, and transform the high voltages used for efficient long distance transmission through the grid to the sub-transmission voltage levels for more cost-effective transmission of power through supply lines to the distribution substations in the surrounding regions. These supply lines are radial express feeders, each connecting the substation to a small number of distribution substations.
3. *Distribution substations* typically operate at 2.4–34.5 kV voltage levels, and deliver electric energy directly to industrial and residential consumers. Distribution feeders transport power from the distribution substations to the end consumers' premises. These feeders serve a large number of premises and usually contain many branches. At the consumers' premises, distribution transformers transform the distribution voltage to the service level voltage directly used in households and industrial plants, usually from 110 to 600 V.

Recently, distributed generation has started to play a larger role in the distribution system supply. These are small-scale power generation technologies (typically in the range of 3–10,000 kW) used to provide an alternative to or an enhancement of the traditional electric power system. Distributed generation includes combined heat and power (CHP), fuel cells, micro-combined heat and power (micro-CHP), micro-turbines, photovoltaic (PV) systems, reciprocating engines, small wind power systems, and Stirling engines, as well as renewable energy sources.

Renewable energy comes from natural resources such as sunlight, wind, rain, tides, and geothermal heat, which are naturally replenished. New renewables (small hydro, modern biomass, wind, solar, geothermal, and biofuels) are growing very rapidly.

A simplified one-line diagram showing all major electrical components from generation to a customer's service is shown in Fig. 2.25.

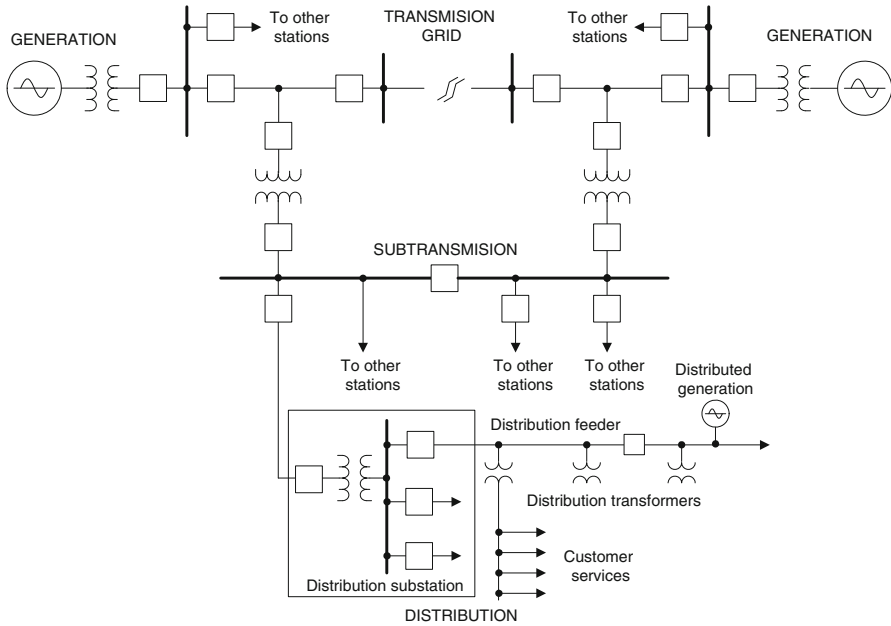

Fig. 2.25 One-line diagram of major components of power system from generation to consumption

### *Distribution Substation Components*

Distribution substations are comprised of the following major components.

#### **Supply Line**

Distribution substations are connected to a sub-transmission system via at least one supply line, which is often called a primary feeder. However, it is typical for a distribution substation to be supplied by two or more supply lines to increase reliability of the power supply in case one supply line is disconnected. A supply line can be an overhead line or an underground feeder, depending on the location of the substation, with underground cable lines mostly in urban areas and overhead lines in rural areas and suburbs. Supply lines are connected to the substation via high-voltage disconnecting switches in order to isolate lines from substation to perform maintenance or repair work.

#### **Transformers**

Transformers “step down” supply line voltage to distribution level voltage. See Fig. 2.26. Distribution substations usually employ three-phase transformers;

**Fig. 2.26** Voltage transformers (Courtesy of General Electric)



however, banks of single-phase transformers can also be used. For reliability and maintenance purposes, two transformers are typically employed at the substation, but the number can vary depending on the importance of the consumers fed from the substation and the distribution system design in general. Transformers can be classified by the following factors:

- (a) *Power rating*, which is expressed in kilovolt-amperes (kVA) or megavolt-amperes (MVA), and indicates the amount of power that can be transferred through the transformer. Distribution substation transformers are typically in the range of 3 kVA to 25 MVA.
- (b) *Insulation*, which includes liquid or dry types of transformer insulation. Liquid insulation can be mineral oil, nonflammable or low-flammable liquids. The dry type includes the ventilated, cast coil, enclosed non-ventilated, and sealed gas-filled types. Additionally, insulation can be a combination of the liquid-, vapor-, and gas-filled unit.
- (c) *Voltage rating*, which is governed by the sub-transmission and distribution voltage levels substation to which the transformer is connected. Also, there are standard voltages nominal levels governed by applicable standards. Transformer voltage rating is indicated by the manufacturer. For example, 115/34.5 kV means the high-voltage winding of the transformer is rated at 115 kV, and the low-voltage winding is rated at 34.5 kV between different phases. Voltage rating dictates the construction and insulation requirements of the transformer to withstand rated voltage or higher voltages during system operation.

- (d) *Cooling*, which is dictated by the transformer power rating and maximum allowable temperature rise at the expected peak demand. Transformer rating includes self-cooled rating at the specified temperature rise or forced-cooled rating of the transformer if so equipped. Typical transformer rated winding temperature rise is 55°C/65°C at ambient temperature of 30°C for liquid-filled transformers to permit 100% loading or higher if temporarily needed for system operation. Modern low-loss transformers allow even higher temperature rise; however, operating at higher temperatures may impact insulation and reduce transformer life.
- (e) *Winding connections*, which indicates how the three phases of transformer windings are connected together at each side. There are two basic connections of transformer windings; delta (where the end of each phase winding is connected to the beginning of the next phase forming a triangle); and star (where the ends of each phase winding are connected together, forming a neutral point and the beginning of windings are connected outside). Typically, distribution transformer is connected delta at the high-voltage side and wye at the low-voltage side. Delta connection isolates the two systems with respect to some harmonics (especially third harmonic), which are not desirable in the system. A wye connection establishes a convenient neutral point for connection to the ground.
- (f) *Voltage regulation*, which indicates that the transformer is capable of changing the low-voltage side voltage in order to maintain nominal voltage at customer service points. Voltage at customer service points can fluctuate as a result of either primary system voltage fluctuation or excessive voltage drop due to the high load current. To achieve this, transformers are equipped with voltage tap regulators. Those can be either no-load type, requiring disconnecting the load to change the tap, or under-load type, allowing tap changing during transformer normal load conditions. Transformer taps effectively change the transformation ratio and allow voltage regulation of  $\pm 10\text{--}15\%$  in steps of 1.75–2.5% per tap. Transformer tap changing can be manual or automatic; however, only under-load type tap changers can operate automatically.

## Busbars

Busbars (also called buses) can be found throughout the entire power system, from generation to industrial plants to electrical distribution boards. Busbars are used to carry large current and to distribute current to multiple circuits within switchgear or equipment (Fig. 2.27). Plug-in devices with circuit breakers or fusible switches may be installed and wired without de-energizing the busbars if so specified by the manufacturer.

Originally, busbars consisted of uncovered copper conductors supported on insulators, such as porcelain, mounted within a non-ventilated steel housing. This type of construction was adequate for current ratings of 225–600 A. As the use of busbars expanded and increased, loads demanded higher current ratings

**Fig. 2.27** Outdoor switchgear busbar (upper conductors) with voltage transformers (Courtesy of General Electric)



and housings were ventilated to provide better cooling at higher capacities. The busbars were also covered with insulation for safety and to permit closer spacing of bars of opposite polarity in order to achieve lower reactance and voltage drop.

By utilizing conduction, current densities are achieved for totally enclosed busbars that are comparable to those previously attained with ventilated busbars. Totally enclosed busbars have the same current rating regardless of mounting position. Bus configuration may be a stack of one busbar per phase (0–800 A), whereas higher ratings will use two (3,000 A) or three stacks (5,000 A). Each stack may contain all three phases, neutral, and grounding conductors to minimize circuit reactance.

Busbars' conductors and current-carrying parts can be either copper, aluminum, or copper alloy rated for the purpose. Compared to copper, electrical grade aluminum has lower conductivity and lower mechanical strength. Generally, for equal current-carrying ability, aluminum is lighter in weight and less costly. All contact locations on current-carrying parts are plated with tin or silver to prevent oxides or insulating film from building up on the surfaces.

In distribution substations, busbars are used at both high side and low side voltages to connect different circuits and to transfer power from the power supply to multiple outgoing feeders. Feeder busbars are available for indoor and outdoor construction. Outdoor busbars are designed to operate reliably despite exposure to the weather. Available current ratings range from 600 to 5,000 A continuous current. Available short-circuit current ratings are 42,000–200,000 A, symmetrical root mean square (RMS).

**Fig. 2.28** Indoor switchgear front view (Courtesy of General Electric)



## Switchgear

Switchgear (Fig. 2.28) is a general term covering primary switching and interrupting devices together with its control and regulating equipment. Power switchgear includes breakers, disconnect switches, main bus conductors, interconnecting wiring, support structures with insulators, enclosures, and secondary devices for monitoring and control. Power switchgear is used throughout the entire power system, from generation to industrial plants to connect incoming power supply and distribute power to consumers. Switchgear can be of outdoor or indoor types, or a combination of both. Outdoor switchgear is typically used for voltages above 26 kV, whereas indoor switchgear is commonly for voltages below 26 kV.

Indoor switchgear can be further classified into metal-enclosed switchgear and open switchgear, which is similar to outdoor switchgear but operates at lower voltages. Metal-enclosed switchgear can be further classified into metal-clad switchgear, low-voltage breaker switchgear, and interrupter switchgear. Metal-clad switchgear is commonly used throughout the industry for distributing supply voltage service above 1,000 V.

Metal-clad switchgear can be characterized as follows:

- (a) The primary voltage breakers and switches are mounted on a removable mechanism to allow for movement and proper alignment.
- (b) Grounded metal barriers enclose major parts of the primary circuit, such as breakers or switches, buses, potential transformers, and control power transformers.
- (c) All live parts are enclosed within grounded metal compartments. Primary circuit elements are not exposed even when the removable element is in the test, disconnected, or in the fully withdrawn position.
- (d) Primary bus conductors and connections are covered with insulating material throughout by means of insulated barriers between phases and between phase and ground.

- (e) Mechanical and electrical interlocking ensures proper and safe operation.
- (f) Grounded metal barriers isolate all primary circuit elements from meters, protective relays, secondary control devices, and wiring. Secondary control devices are mounted on the front panel, and are usually swing type as shown in Fig. 2.28.

Switchgear ratings indicate specific operating conditions, such as ambient temperature, altitude, frequency, short-circuit current withstand and duration, overvoltage withstand and duration, etc. The rated continuous current of a switchgear assembly is the maximum current in RMS (root mean square) amperes, at rated frequency, that can be carried continuously by the primary circuit components without causing temperatures in excess of the limits specified by applicable standards.

### Outcoming Feeders

A number of outcoming feeders are connected to the substation bus to carry power from the substation to points of service. Feeders can be run overhead along streets, or beneath streets, and carry power to distribution transformers at or near consumer premises. The feeders' breaker and isolator are part of the substation low-voltage switchgear and are typically the metal-clad type. When a fault occurs on the feeder, the protection will detect it and open the breaker. After detection, either automatically or manually, there may be one or more attempts to reenergize the feeder. If the fault is transient, the feeder will be reenergized and the breaker will remain closed. If the fault is permanent, the breaker will remain open and operating personnel will locate and isolate the faulted section of the feeder.

### Switching Apparatus

Switching apparatus is needed to connect or disconnect elements of the power system to or from other elements of the system. Switching apparatus includes switches, fuses, circuit breakers, and service protectors.

- (a) *Switches* are used for isolation, load interruption, and transferring service between different sources of supply.

Isolating switches are used to provide visible disconnect to enable safe access to the isolated equipment. These switches usually have no interrupting current rating, meaning that the circuit must be opened by other means (such as breakers). Interlocking is generally provided to prevent operation when the switch is carrying current.

Load interrupting or a load-break switch combines the functions of a disconnecting switch and a load interrupter for interrupting at rated voltage and currents not exceeding the continuous-current rating of the switch. Load-break switches are of the air- or fluid-immersed type. The interrupter switch is



usually manually operated and has a “quick-make, quick-break” mechanism which functions independently of the speed-of-handle operation. These types of switches are typically used on voltages above 600 V.

For services of 600 V and below, safety circuit breakers and switches are commonly used. Safety switches are enclosed and may be fused or un-fused. This type of switch is operated by a handle outside the enclosure and is interlocked so that the enclosure cannot be opened unless the switch is open or the interlock defeater is operated.

Transfer switches can be operated automatically or manually. Automatic transfer switches are of double-throw construction and are primarily used for emergency and standby power generation systems rated at 600 V and lower. These switches are used to provide protection against normal service failures.

- (b) *Fuses* are used as an over-current-protective device with a circuit-opening fusible link that is heated and severed as over-current passes through it. Fuses are available in a wide range of voltage, current, and interrupting ratings, current-limiting types, and for indoor and outdoor applications. Fuses perform the same function as circuit breakers, and there is no general rule for using one versus the other. The decision to use a fuse or circuit breaker is usually based on the particular application, and factors such as the current interrupting requirement, coordination with adjacent protection devices, space requirements, capital and maintenance costs, automatic switching, etc.
- (c) *Circuit breakers* (Fig. 2.29) are devices designed to open and close a circuit either automatically or manually. When applied within its rating, an automatic circuit breaker must be capable of opening a circuit automatically on a predetermined overload of current without damaging itself or adjacent elements. Circuit breakers are required to operate infrequently, although some classes of circuit breakers are suitable for more frequent operation. The interrupting and momentary ratings of a circuit breaker must be equal to or greater than the available system short-circuit currents.

Circuit breakers are available for the entire system voltage range, and may be as furnished single-, double-, triple-, or four-pole, and arranged for indoor or outside use. Sulfur hexafluoride (SF<sub>6</sub>) gas-insulated circuit breakers are available for medium and high voltages, such as gas-insulated substations.

When a current is interrupted, an arc is generated. This arc must be contained, cooled, and extinguished in a controlled way so that the gap between the contacts can again withstand the voltage in the circuit. Circuit breakers can use vacuum, air, insulating gas, or oil as the medium in which the arc forms. Different techniques are used to extinguish the arc, including:

- Lengthening the arc
- Intensive cooling (in jet chambers)
- Division into partial arcs
- Zero point quenching (contacts open at the zero current time crossing of the AC waveform, effectively breaking no-load current at the time of opening)
- Connecting capacitors in parallel with contacts in DC circuits

**Fig. 2.29** Breaker of indoor switchgear, rear “bus” side (Courtesy of General Electric)

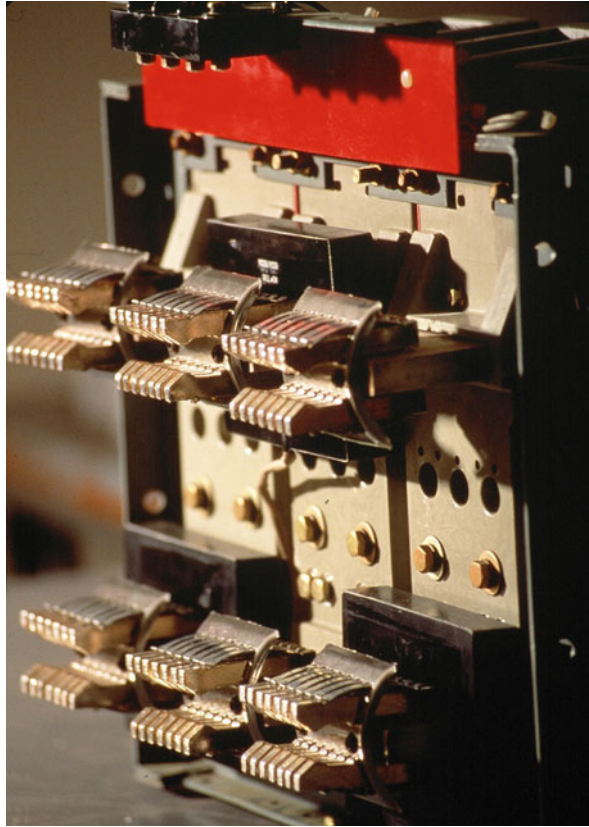

Traditionally, oil circuit breakers (Fig. 2.30) were used in the power industry, which use oil as a media to extinguish the arc and rely upon vaporization of some of the oil to blast a jet of oil through the arc.

Gas (usually sulfur hexafluoride) circuit breakers sometimes stretch the arc using a magnetic field, and then rely upon the dielectric strength of the sulfur hexafluoride to quench the stretched arc.

Vacuum circuit breakers have minimal arcing (as there is nothing to ionize other than the contact material), so the arc quenches when it is stretched by a very small amount ( $<2\text{--}3$  mm). Vacuum circuit breakers are frequently used in modern medium-voltage switchgear up to 35 kV.

Air blast circuit breakers may use compressed air to blow out the arc, or alternatively, the contacts are rapidly swung into a small sealed chamber, where the escaping displaced air blows out the arc.

Circuit breakers are usually able to terminate all current very quickly: Typically the arc is extinguished between 30 and 150 ms after the mechanism has tripped, depending upon age and construction of the device.

Indoor circuit breakers are rated to carry 1–3 kA current continuously, and interrupting 8–40 kA short-circuit current at rated voltage.

**Fig. 2.30** Outdoor medium-voltage oil-immersed circuit breaker (Courtesy of General Electric)



### Surge Voltage Protection

Transient overvoltages are due to natural and inherent characteristics of power systems. Overvoltages may be caused by lightning or by a sudden change of system conditions (such as switching operations, faults, load rejection, etc.), or both. Generally, the overvoltage types can be classified as lightning generated and as switching generated. The magnitude of overvoltages can be above maximum permissible levels, and therefore needs to be reduced and protected against to avoid damage to equipment and undesirable system performance.

The occurrence of abnormal applied overvoltage stresses, either short term or sustained steady state, contributes to premature insulation failure. Large amounts of current may be driven through the faulted channel, producing large amounts of heat. Failure to suppress overvoltage quickly and effectively or interrupt high short-circuit current can cause massive damage of insulation in large parts of the power system, leading to lengthy repairs.

The appropriate application of surge-protective devices will lessen the magnitude and duration of voltage surges seen by the protected equipment. The problem is complicated by the fact that insulation failure results from impressed overvoltages, and because of the aggregate duration of repeated instances of overvoltages.

Surge arresters have been used in power systems to protect insulation from overvoltages. Historically, the evolution of surge arrester material technology has produced various arrester designs, starting with the valve-type arrester, which has been used almost exclusively on power system protection for decades. The active element (i.e., valve element) in these arresters is a nonlinear resistor that exhibits relatively high resistance (megaohms) at system operating voltages, and a much lower resistance (ohms) at fast rate-of-rise surge voltages.

In the mid-1970s, arresters with metal-oxide valve elements were introduced. Metal-oxide arresters have valve elements (also of sintered ceramic-like material) of a much greater nonlinearity than silicon carbide arresters, and series gaps are no longer required. The metal-oxide designs offer improved protective characteristics and improvement in various other characteristics compared to silicon carbide designs. As a result, metal-oxide arresters have replaced gapped silicon carbide arresters in new installations.

In the mid-1980s, polymer housings began to replace porcelain housings on metal-oxide surge arresters offered by some manufacturers. The polymer housings are made of either EPDM (ethylene propylene diene monomer [M-class] rubber) or silicone rubber. Distribution arrester housings were first made with polymer, and later expanded into the intermediate and some station class ratings. Polymer housing material reduces the risk of injuries and equipment damage due to surge arrester failures.

Arresters have a dual fundamental-frequency (RMS) voltage rating (i.e., duty-cycle voltage rating), and a corresponding maximum continuous operating voltage rating. Duty-cycle voltage is defined as the designated maximum permissible voltage between the terminals at which an arrester is designed to perform.

## Grounding

Grounding is divided into two categories: power system grounding and equipment grounding.

*Power system grounding* means that at some location in the system there are intentional electric connections between the electric system phase conductors and ground (earth). System grounding is needed to control overvoltages and to provide a path for ground-current flow in order to facilitate sensitive ground-fault protection based on detection of ground-current flow. System grounding can be as follows:

- Solidly grounded
- Ungrounded
- Resistance grounded

Each grounding arrangement has advantages and disadvantages, with choices driven by local and global standards and practices, and engineering judgment.

Solidly grounded systems are arranged such that circuit protective devices will detect a faulted circuit and isolate it from the system regardless of the type of fault. All transmission and most sub-transmission systems are solidly grounded for

system stability purposes. Low-voltage service levels of 120–480 V four-wire systems must also be solidly grounded for safety of life. Solid grounding is achieved by connecting the neutral of the wye-connected winding of the power transformer to the ground.

Where service continuity is required, such as for a continuously operating process, the resistance grounded power system can be used. With this type of grounding, the intention is that any contact between one phase conductor and a ground will not cause the phase over-current protective device to operate. Resistance grounding is typically used from 480 V to 15 kV for three-wire systems. Resistance grounding is achieved by connecting the neutral of the wye-connected winding of the power transformer to the ground through the resistor, or by employing special grounding transformers.

The operating advantage of an ungrounded system is the ability to continue operations during a single phase-to-ground fault, which, if sustained, will not result in an automatic trip of the circuit by protection. Ungrounded systems are usually employed at the distribution level and are originated from delta-connected power transformers.

*Equipment grounding* refers to the system of electric conductors (grounding conductor and ground buses) by which all non-current-carrying metallic structures within an industrial plant are interconnected and grounded. The main purposes of equipment grounding are:

- To maintain low potential difference between metallic structures or parts, minimizing the possibility of electric shocks to personnel in the area
- To contribute to adequate protective device performance of the electric system, and safety of personnel and equipment
- To avoid fires from volatile materials and the ignition of gases in combustible atmospheres by providing an effective electric conductor system for the flow of ground-fault currents and lightning and static discharges to eliminate arcing and other thermal distress in electrical equipment

Substation grounding systems are thoroughly engineered. In an electrical substation, a ground (earth) mat is a mesh of metal rods connected together with conductive material and installed beneath the earth surface. It is designed to prevent dangerous ground potential from rising at a place where personnel would be located when operating switches or other apparatus. It is bonded to the local supporting metal structure and to the switchgear so that the operator will not be exposed to a high differential voltage due to a fault in the substation.

## **Power Supply Quality**

The quality of electrical power may be described as a set of values or parameters, such as:

- Continuity of service



**Fig. 2.31** Capacitor Bank (Courtesy of General Electric)

- Variation in voltage magnitude
- Transient voltages and currents
- Harmonic content in the supply voltages

Continuity of service is achieved by proper design, timely maintenance of equipment, reliability of all substation components, and proper operating procedures. Recently, remote monitoring and control have greatly improved the power supply continuity.

When the voltage at the terminals of utilization equipment deviates from the value on the nameplate of the equipment, the performance and the operating life of the equipment are affected. Some pieces of equipment are very sensitive to voltage variations (e.g., motors). Due to voltage drop down the supply line, voltage at the service point may be much lower compared with the voltage at substation. Abnormally low voltage occurs at the end of long circuits. Abnormally high voltage occurs at the beginning of circuits close to the source of supply, especially under lightly loaded conditions such as at night and during weekends. Voltage regulators are used at substations to improve the voltage level supplied from the distribution station. This is achieved by a tap changer mounted in the transformer and an automatic voltage regulator that senses voltage and voltage drop due to load current to increase or decrease voltage at the substation.

If the load power factor is low, capacitor banks (Fig. 2.31) may be installed at the substation to improve the power factor and reduce voltage drop. Capacitor banks are especially beneficial at substations near industrial customers where reactive power is needed for operation of motors.

Transients in voltages and currents may be caused by several factors, such as large motor starting, fault in the sub-transmission or distribution system, lightning, welding equipment and arc furnace operation, turning on or off large loads, etc. Lighting equipment output is sensitive to applied voltage, and people are sensitive to sudden illumination changes. A voltage change of 0.25–0.5% will cause a noticeable reduction in the light output of an incandescent lamp. Events causing such voltage effects are called flicker (fast change of the supply voltage), and voltage sags (depressed voltage for a noticeable time). Both flicker and sags have operational limits and are governed by industry and local standards.

Voltage and current on the ideal AC power system have pure single frequency sine wave shapes. Power systems have some distortion because an increasing number of loads require current that is not a pure sine wave. Single- and three-phase rectifiers, adjustable speed drives, arc furnaces, computers, and fluorescent lights are good examples. Capacitor failure, premature transformer failure, neutral overloads, excessive motor heating, relay misoperation, and other problems are possible when harmonics are not properly controlled.

Harmonics content is governed by appropriate industry and local standards, which also provide recommendations for control of harmonics in power systems.

### ***Substation Design Considerations***

Distribution substation design is a combination of reliability and quality of the power supply, safety, economics, maintainability, simplicity of operation, and functionality.

Safety of life and preservation of property are the two most important factors in the design of the substation. Codes must be followed and recommended practices or standards should be followed in the selection and application of material and equipment. Following are the operating and design limits that should be considered in order to provide safe working conditions:

- Interrupting devices must be able to function safely and properly under the most severe duty to which they may be exposed.
- Accidental contact with energized conductors should be eliminated by means of enclosing the conductors, installing protective barriers, and interlocking.
- The substation should be designed so that maintenance work on circuits and equipment can be accomplished with these circuits and equipment de-energized and grounded.
- Warning signs should be installed on electric equipment accessible to both qualified and unqualified personnel, on fences surrounding electric equipment, on access doors to electrical rooms, and on conduits or cables above 600 V in areas that include other equipment.
- An adequate grounding system must be installed.

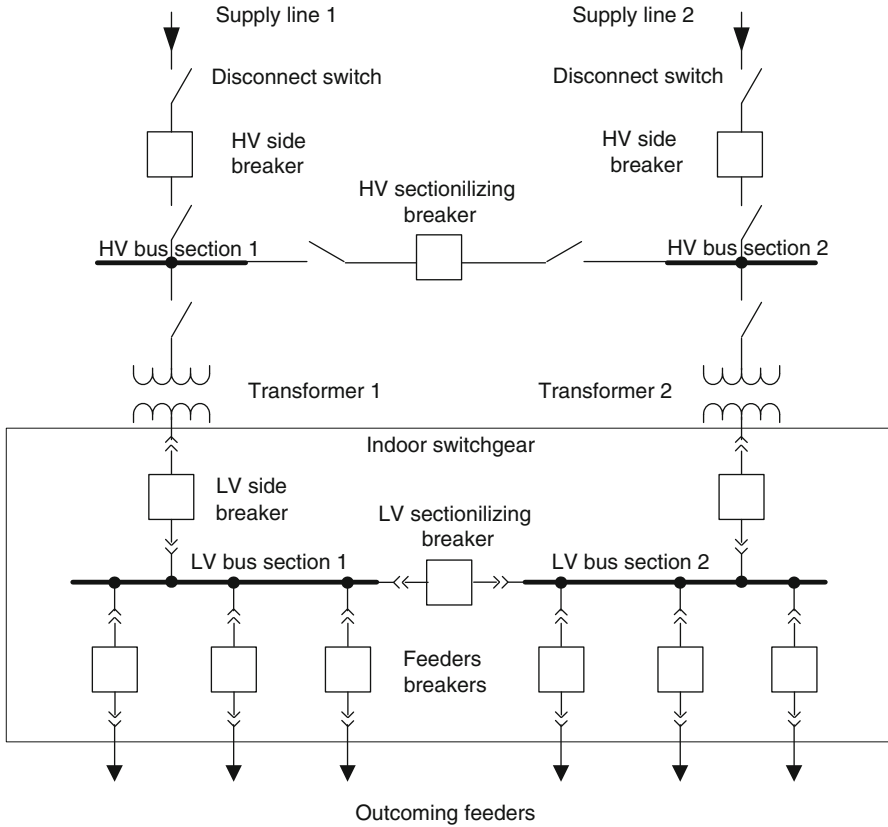

**Fig. 2.32** Example one-line diagram of distribution substation with two transformers and two supply lines

- Emergency lights should be provided where necessary to protect against sudden lighting failure.
- Operating and maintenance personnel should be provided with complete operating and maintenance instructions, including wiring diagrams, equipment ratings, and protective device settings.

A variety of basic circuit arrangements are available for distribution substations. Selection of the best system or combination of systems will depend upon the needs of the power supply process. In general, system costs increase with system reliability if component quality is equal. Maximum reliability per unit investment can be achieved by using properly applied and well-designed components.

Figure 2.32 provides an example of the distribution substation one-line diagram with two transformers, two supply lines, and two sections at both the high-voltage (HV) side and low-voltage (LV) sides, with sectionalizing breakers at both HV and LV voltages. Such an arrangement provides redundancy and reliability in case of



any component failure by transferring the power supply from one section to another. Additionally, any component of the substation can be taken out of service for maintenance.

If the substation is designed to supply a manufacturing plant, continuity of service may be critical. Some plants can tolerate interruptions while others require the highest degree of service continuity. The system should always be designed to isolate faults with a minimum disturbance to the system, and should have features to provide the maximum dependability consistent with the plant requirements and justifiable cost. The majority of utilities today supply energy to medium and large industrial customers directly at 34.5, 69, 115, 138, 161, and 230 kV using dedicated substations. Small industrial complexes may receive power at voltages as low as 4 kV.

Poor voltage regulation is harmful to the life and operation of electrical equipment. Voltage at the utilization equipment must be maintained within equipment tolerance limits under all load conditions, or equipment must be selected to operate safely and efficiently within the voltage limits. Load-flow studies and motor-starting calculations are used to verify voltage regulation.

### ***Substation Standardization***

Standards, recommended practices, and guides are used extensively in communicating requirements for design, installation, operation, and maintenance of substations. Standards establish specific definitions of electrical terms, methods of measurement and test procedures, and dimensions and ratings of equipment. Recommended practices suggest methods of accomplishing an objective for specific conditions. Guides specify the factors that should be considered in accomplishing a specific objective. All are grouped together as standards documents.

Standards are used to establish a small number agreed to by the substation community of alternative solutions from a range of possible solutions. This allows purchasers to select a specific standard solution knowing that multiple vendors will be prepared to supply that standard, and that different vendor's products will be able to interoperate with each other. Conversely, this allows vendors to prepare a small number of solutions knowing that a large number of customers will be specifying those solutions. Expensive and trouble-prone custom "one-of-a-kind" design and manufacturing can be avoided. For example, out of the almost infinite range of voltage ratings for 3-wire 60 Hz distribution substation low side equipment, NEMA C84.1 standardizes only seven: 2,400, 4,160, 4,800, 6,900, 13,800, 23,000, and 34,500 V. Considerable experience and expertise goes into the creation and maintenance of standards, providing a high degree of confidence that solutions implemented according to a standard will perform as expected. Standards also allow purchasers to concisely and comprehensively state their requirements, and allow vendors to concisely and comprehensively state their products' performance.

There are several bodies publishing standards relevant to substations. Representative of these are the following:

The Institute of Electrical and Electronics Engineers (IEEE) is a nonprofit, transnational professional association having 38 societies, of which the Power and Energy Society (PES) is “involved in the planning, research, development, construction, installation, and operation of equipment and systems for the safe, reliable, and economic generation, transmission, distribution, measurement, and control of electric energy.” PES includes several committees devoted to various aspects of substations that publish a large number of standards applicable to substations. For more information, visit [www.ieee-pes.org](http://www.ieee-pes.org).

The National Electrical Manufacturers Association (NEMA) is a trade association of the electrical manufacturing industry that manufactures products used in the generation, transmission and distribution, control, and end-use of electricity. NEMA provides a forum for the development of technical standards that are in the best interests of the industry and users; advocacy of industry policies on legislative and regulatory matters; and collection, analysis, and dissemination of industry data. For more information, visit [www.nema.org](http://www.nema.org).

American National Standards Institute (ANSI) oversees the creation, promulgation, and use of thousands of norms and guidelines that directly impact businesses in nearly every sector, including energy distribution. ANSI is also actively engaged in accrediting programs that assess conformance to standards – including globally recognized cross-sector programs such as the ISO 9000 (quality) and ISO 14000 (environmental) management systems. For more information, see [www.ansi.org](http://www.ansi.org).

National Fire Protection Association (NFPA) is an international nonprofit organization established in 1896 to reduce the worldwide burden of fire and other hazards on the quality of life by providing and advocating consensus codes and standards, research, training, and education. NFPA develops, publishes, and disseminates more than 300 consensus codes and standards intended to minimize the possibility and effects of fire and other risks. Of particular interest to substations is the National Electrical Code (NEC). For more information, see [www.nfpa.org](http://www.nfpa.org).

International Electrotechnical Commission (IEC) technical committee is an organization for the preparation and publication of International Standards for all electrical, electronic, and related technologies. These are known collectively as “electrotechnology.” IEC provides a platform to companies, industries, and governments for meeting, discussing, and developing the International Standards they require. All IEC International Standards are fully consensus based and represent the needs of key stakeholders of every nation participating in IEC work. Every member country, no matter how large or small, has one vote and a say in what goes into an IEC International Standard. For more information, see [www.iec.ch](http://www.iec.ch).

International Organization for Standardization (ISO) is a nongovernmental organization that forms a bridge between the public and private sectors. Many of its member institutes are part of the governmental structure of their countries, or are

mandated by their government while other members have their roots uniquely in the private sector, having been set up by national partnerships of industry associations. ISO enables a consensus to be reached on solutions that meet both the requirements of business and the broader needs of society. For more information, see [www.iso.org](http://www.iso.org).

International Telecommunication Union (ITU) is the United Nations' agency for information and communication technology issues, and the global focal point for governments and the private sector in developing networks and services. For 145 years, ITU has coordinated the shared global use of the radio spectrum, promoted international cooperation in assigning satellite orbits, worked to improve telecommunication infrastructure in the developing world, established the worldwide standards that foster seamless interconnection of a vast range of communications systems, and addressed the global challenges of our times, such as mitigating climate change and strengthening cyber security. For more information, see [www.itu.int](http://www.itu.int).

### ***Substation Physical Appearance***

It is desirable to locate distribution substations as near as possible to the load center of its service area, though this requirement is often difficult to satisfy. Locations that are perfect from engineering and cost points of view are sometimes prohibited due to physical, electrical, neighboring, or aesthetic considerations. Given the required high- and low-voltage requirements and the required power capacity, a low-cost above-ground design will satisfy power supply needs. However, an aboveground design requires overhead sub-transmission line structures (Fig. 2.33), which are often undesirable structures for neighborhoods. Therefore, incoming lines are often underground cables, and the entire substation is designed to be as unobtrusive as possible.

Underground cables are more costly than overhead lines for the same voltage and capacity. Installation of underground cables in urban areas is also often inconvenient and potentially hazardous.

Local conditions or system-wide policy may require landscaping at a substation site or for housing the substation within a building. A fence with warning signs or other protective enclosures is typically provided to keep unauthorized persons from coming in close proximity of the high-voltage lines and substation equipment. Alarm systems and video surveillance are becoming normal practices for monitoring and preventing intrusion by unauthorized persons.

### ***Protection and Automation***

The purpose of protection in distribution substations is to isolate faulted power system elements, such as feeders and transformers, from sources of electrical supply in order to:

**Fig. 2.33** Distribution substation view (Courtesy of General Electric)



- Prevent damage to un-faulted equipment that might otherwise result from sustained fault-level currents and/or voltages
- Reduce the probability and degree of harm to the general public, utility personnel, and property
- Reduce the amount of damage the faulted element sustains, thus containing repair costs, service interruption duration, and impact on the environment
- Clear transient faults and restore service

To accomplish this, protection devices must be able to rapidly determine that a fault has occurred, determine which system element or which section of the system has faulted, and to open the circuit breakers and switches that will disconnect the faulted element. To do this reliably, means must be provided to clear faults even in the event of a single failure in the protection system.

Substation automation facilities complement protection at distribution substations. In the past, automation at distribution substations was limited to automatic tap changer control and capacitor auto-switching to regulate voltage. Automation and communication facilities in modern distribution substations provide visibility to the system operator of the state of the substation, allowing rapid identification of the source and cause of interruptions and other troubles, and providing the ability to dispatch repair personnel quickly to the correct location and with the necessary equipment and spares to effect a repair. In these modern distribution substations, automation facilities often provide operators with the ability to remotely open and close breakers and switches, allowing power rerouting to restore service.

The principle by which protection operates depends to a large degree on the element covered by the protection. Common element types are as follows.

## **Incoming Sub-transmission Supply Line Protection at Distribution Substations**

In the past, distribution substations supplied only loads; there was little if any distributed generation. With this arrangement, faults on the incoming sub-transmission supply line do not result in energy flowing out of the distribution substation and into the supply line (i.e., backfeed). In that event, opening of the distribution substation end of the supply line is not necessary to isolate supply line faults; opening of the source end by protection located there is all that is necessary.

Recently, distributed generation from windmills, bio-digesters, mini-hydraulics, and photovoltaic sources has been increasing dramatically, in some cases to the point where the contribution to the supply line faults and must be interrupted to extinguish the fault. Various protection technologies exist to detect such faults, including reverse flow, distance, and current differential.

Reverse flow protection detects the reversal from the normal direction of power and/or current flow. This type of protection is only suitable for cases where the amount of distributed generation in relation to the amount of load is small enough that under normal un-faulted conditions the flow from the supply line is always into the distribution substation. Reverse flow occurs when a supply line fault causes voltage depression to the point where load current essentially disappears, yet the distributed generators continue to source current.

Distance protection estimates the impedance of the supply line between the distribution substation and a fault on the supply line. Supply lines typically have a constant amount of impedance per unit distance (e.g., per kilometer), so the impedance seen at the distribution substation is larger for a fault beyond the end of the supply line than for a fault on the supply line. Distance protection thus can usually discriminate between these two faults, and avoid unnecessary tripping for faults beyond the supply line. To a first approximation, impedance is simply the voltage divided by the current.

Current differential protection is based on the fact that the algebraic sum of all supply line terminal currents is equal to the supply line fault current, if any. Current resulting from external faults and from load flowing into the supply line is canceled as it flows out. Charging current is typically negligible at sub-transmission voltage levels.

With each of these three methods, current transformers (CTs) are needed to measure supply line current, and except for current differential, voltage transformers (VTs) are needed to measure the voltage at the distribution substation. With current differential, a communications channel to the other end(s) of the supply line is needed. A relay (also known as an IED) is needed to detect the supply line fault and discriminate it from other conditions such as faults on other elements. Also, a circuit breaker or circuit switcher is needed to interrupt the supply line connection on command from the relay.

**Fig. 2.34** Modern digital transformer protection relay (Courtesy of General Electric)



### Distribution Substation Transformer Protection

In distribution substations with relatively small delta/wye transformers (typically less than 10 MVA), transformer protection often consists of simple fusing. A power fault in the transformer or on the low side bus typically produces a large current in the high side terminals that melts the fusible links, interrupting the fault. Internal turn-to-turn winding faults that produce only small terminal fault currents are allowed to burn until the fault evolves into a fault with current large enough to operate the fuses. This is acceptable because there is little or no difference in the commercial value of faulted transformers, and because small transformers on which fuses are used are less costly.

On larger (and more expensive) transformers, through-current restrained differential relays (Fig. 2.34) are most often employed. These protections require CTs measuring all current paths in and out of the transformer. Most often, the CTs are mounted on the high side terminals of the transformer and on the breaker(s) that directly connect to the low side terminals. Where there is no breaker between the transformer and the low side bus, the bus is also covered. The operating principle of transformer current differential protection is based on the incoming high side current under normal and under external fault conditions approximately equaling the sum of the outgoing low side currents after adjusting for the transformer's transformation ratio and internal connection (e.g., delta/wye). During internal fault conditions, there is a large inequality.

Invariably, there is actually some difference between these (even in a healthy transformer) that is a small but constant percentage of the current flowing through the transformer. An on-load tap changer is an example of what can cause such a difference. For large through-currents, such as occurring during external low side faults, the difference is substantial, so the relay employs through-current restraint. The differential operating threshold is made dynamic by including in the trip threshold a percentage of the measured through-current.

Another problem with transformer differential protection is that when the transformer itself is saturated, which usually occurs on energization, relatively large currents flow through the excitation impedance, which appear to the

protection as differential current with no through-current. Energization current, however, contains a large harmonic component. Relays therefore monitor for the presence of such harmonics, most often the second harmonic, and when found block the differential element.

When a transformer fault is detected, the transformer is isolated by opening its high side connection. Where there are fuses, the fuses perform the interruption. Where there is a high side breaker or circuit switcher, they are tripped. Otherwise, a trip signal is sent to trip the remote end of the supply line. This signal may be via radio, optical fiber, or metallic pair, or may be the closing a switch that grounds one phase of the supply line causing the remote end to see and trip as for a supply line fault. Where there are distributed generators on the distribution system, the distributed generators or the distribution substation's low side breakers must be opened as well. Opening of low side breakers is often done even when there are no distributed generators.

### **Distribution Substation Bus Protection**

When fuses protect a distribution substation transformer and there is no transformer low side breaker and the differential uses feeder breaker CTs, the transformer protection covers the low side bus as well as the transformer.

Where a separate bus protection is used, there are several alternatives for detecting bus faults, including low impedance current differential, high impedance differential, and zone-interlocked schemes.

Low impedance bus differential with through-current restraint operates on the same basic principle as transformer differential protection. Buses have no significant energization current, so harmonic blocking is not implemented. Also there is no need to adjust for transformer connection. However, there are typically many more feeders to measure than in transformer differential applications, so a relay designed for bus protection is required. Low impedance bus differential protections without through-current restraint have been deployed, but often have trouble with CT saturation, causing unnecessary tripping.

High impedance bus differential protections include a simple over-current relay with a large stabilizing resistor connected in series. The relay current is from the parallel connection of the secondary windings of CTs measuring all bus connections. The CTs should be identical in type and ratio. With no fault, the current flowing into the bus is balanced by the current flowing out of the bus (a pattern that is matched in the CT secondary circuit), and thus little or no current flows through the over-current relay. The stabilizing resistor tends to prevent large external fault currents from saturating the CT of the faulted feeder and producing erroneous differential current.

Zone-interlocked schemes (also known as bus-blocking schemes) employ an over-current relay measuring infeed current from the main transformer. On detecting fault current, this over-current relay trips the bus unless one of the feeder protections sees a feeder fault and sends a blocking signal. Bus tripping is delayed

by a short time to ensure that the feeder protections have sufficient time to detect and block for feeder faults.

No matter the detection method used, when a bus fault is detected, the fault current coming from the main transformer must be interrupted. Where there is a transformer low side breaker, it is opened. Otherwise, the transformer high side is opened using one or more of the methods described in the transformer protection section. Where there are distributed generators on the distribution system, the distributed generators or the distribution substation's low side breakers or circuit switchers must be opened as well. Opening of low side breakers is often done even when there are no distributed generators.

### **Distribution Feeder Protection**

Distribution feeder protection at distribution substations is most often instantaneous and timed over-current functionality. Very often, these functions are implemented within a recloser, which is essentially a circuit breaker packaged with a mechanism that repeatedly trips when current exceeds a set threshold, and then recloses or locks out after a series of set delays. Alternatively, an electronic relay with instantaneous and inverse time over-current features is used.

Distribution feeders (Fig. 2.35) typically have fuses along its length and/or on lateral sections intended to separate a faulted section, allowing the rest to be supplied pending repair. Feeder protections usually implement either a fuse-saving or a trip-saving scheme.

Aerial feeders are prone to transient faults, faults that due to lightning or winding-induced swaying (the technical term is "galloping") disappear when the fault current is interrupted and the arc extinguished. A fuse-saving scheme is often used on these. Such a scheme has in normal conditions an instantaneous over-current element that trips the feeder breaker immediately upon detecting a fault. High speed tripping is used to prevent any fuses between the substation and the fault from melting. After the fault current has been interrupted, the instantaneous element is blocked, an inverse time element is enabled, and the feeder breaker reclosed. For transient faults, on reclosing, the fault will have disappeared and supply to all customers is restored. After a short delay of typically a few seconds, the scheme is reset and the instantaneous element placed back in service. For permanent faults, on reclosing, fault current will again flow, and the inverse time relay will start to operate. The inverse time relay is set to coordinate with the fuses such that if there is a fuse between the substation and the fault, the fuse will operate, interrupting customers on the section it supplies, but leaving all others energized. If the fault is located before any fuse, the inverse time relay will time out and trip the entire feeder.

Underground cable feeders rarely have transient faults; cable faults are almost always permanent. A trip-saving scheme is often used on these. Such a scheme has in normal conditions an inverse time element that trips the feeder only after sufficient time for any fuse between the substation and the fault to operate, interrupting customers on the section it supplies, but leaving all others energized.



**Fig. 2.35** Modern digital feeder protection relay (Courtesy of General Electric)



If the fault is located before any fuse, the inverse time relay will time out and trip the entire feeder. Following the feeder trip, an automatic reclose with instantaneous tripping may be attempted to restore service in cases of a fuse having melted but having been unable to interrupt fault current prior to the first trip.

Occasionally, distribution substation feeder protection includes distance supervision to prevent unnecessary tripping feeder tripping for faults on the low side of large distribution transformers near the substation. Such faults should instead be cleared at the distribution transformer location so that other customers on the feeder are not interrupted.

## High Penetration of Distributed Generation and Its Impact on System Design and Operations

High penetration of distributed generation presents significant challenges to design and engineering practices as well as to the reliable operation of the electrical distribution system. The large-scale implementation of distributed energy resources (DER) on system design, performance, and reliable operation requires an integrated approach focused on interoperability, adaptability, and scalability.

## *Vision for Modern Utilities*

### **Centralized Versus Distributed Generation**

The bulk of electric power used worldwide is produced at central power plants, most of which utilize large fossil fuel combustion, hydro or nuclear reactors. A majority of these central stations have an output between 30 MW (industrial plant) and 1,700 MW. This makes them relatively large in terms of both physical size and facility requirements as compared with DG alternatives. In contrast, DG is:

- Installed at various locations (closer to the load) throughout the power system
- Not centrally dispatched (although the development of “virtual” power plants, where many decentralized DG units operate as one single unit, may be an exception to this definition)
- Defined by power rating in a wide range from a few kW to tens of MW (in some countries MW limitation is defined by standards, e.g., US, IEEE 1547 defines DG up to 10 MW – either as a single unit or aggregate capacity)
- Connected to the distribution/medium-voltage network – which generally refers to the part of the network that has an operating voltage of 600 V up to 110 kV (depends on the utility/country)

The ownership of the DG is not a factor as to whether a power generator is classified as DG. DG can be owned or operated by electric customers, energy service companies, independent power producers (IPP), or utilities.

The main reasons why central, rather than distributed, generation still dominates current electricity production include economy of scale, fuel cost and availability, and lifetime. Increasing the size of a production unit decreases the cost per MW; however, the advantage of economy of scale is decreasing – technological advances in fuel conversion have improved the economy of small units. Fuel cost and availability is still another reason to keep building large power plants. Additionally, with a lifetime of 25–50 years, large power plants will continue to remain the prime source of electricity for many years to come [1].

The benefits of distributed generation include: higher efficiency; improved security of supply; improved demand-response capabilities; avoidance of overcapacity; better peak load management; reduction of grid losses; network infrastructure cost deferral (CAPEX deferral); power quality support; improved reliability; and environmental and aesthetic concerns (offers a wide range of alternatives to traditional power system design). DG offers extraordinary value because it provides a flexible range of combinations between cost and reliability. In addition, DG may eventually become a more desirable generation asset because it is “closer” to the customer and is more economical than central station generation and its associated transmission infrastructure [2]. The disadvantages of DG are ownership and operation, fuel delivery (machine-based DG, remote locations), cost of connection, dispatchability, and controllability (wind and solar).

## *Development of “Smart Grid”*

In recent years, there has been rapidly growing interest in what is called “smart grid – digitized grid – grid of the future.” The concept of smart grids has many definitions and interpretations dependent on the specific country, region, and industry stakeholder’s drivers and desirable outcomes and benefits.

The Smart Grids European Technology Platform (which is comprised of European stakeholders, including the research community) defines “a Smart Grid [as] an electricity network that can intelligently integrate the actions of all users connected to it – generators, consumers and those that do both, in order to efficiently deliver sustainable, economic and secure electricity supply” [1].

In North America, the two dominant definitions of the smart grid come from the Department of Energy (DOE) and the Electric Power Research Institute (EPRI).

- *US DOE*: “Grid 2030 envisions a fully automated power delivery network that monitors and controls every customer and node, ensuring two-way flow of information and electricity between the power plant and the appliance, and all points in between” [2].
- *EPRI*: “The term ‘Smart Grid’ refers to a modernization of the electricity delivery system so it monitors, protects, and automatically optimizes the operation of its interconnected elements — from the central and distributed generator through the high-voltage network and distribution system, to industrial users and building automation systems, to energy storage installations and to end-use consumers and their thermostats, electric vehicles, appliances, and other household devices” [3].

Beyond a specific, stakeholder-driven definition, smart grids should refer to the entire power grid from generation through transmission and distribution infrastructure all the way to a wide array of electricity consumers (Fig. 2.36).

Effective deployment of smart grid technologies requires well-defined and quantified benefits. These benefits can be quantified in the areas of technical and business performance, environmental goals, security of electricity supply, and macro-economic growth and business sustainability development. One of the key components to effectively enable full-value realization is technology – the wide range of technical functionalities and capabilities deployed and integrated as one cohesive end-to-end solution supported by an approach focused on scalability, interoperability, and adaptability. Smart grid technologies can be broadly captured under the following areas:

- *Low Carbon*: For example, large-scale renewable generation, distributed energy resources (DER), electric vehicles (EV), and carbon capture and sequestration (CCS).
- *Grid Performance*: For example, advanced distribution and substation automation (self-healing); wide-area adaptive protection schemes (special protection schemes); wide-area monitoring and control systems (power management unit [PMU]-based situational awareness); asset performance optimization and

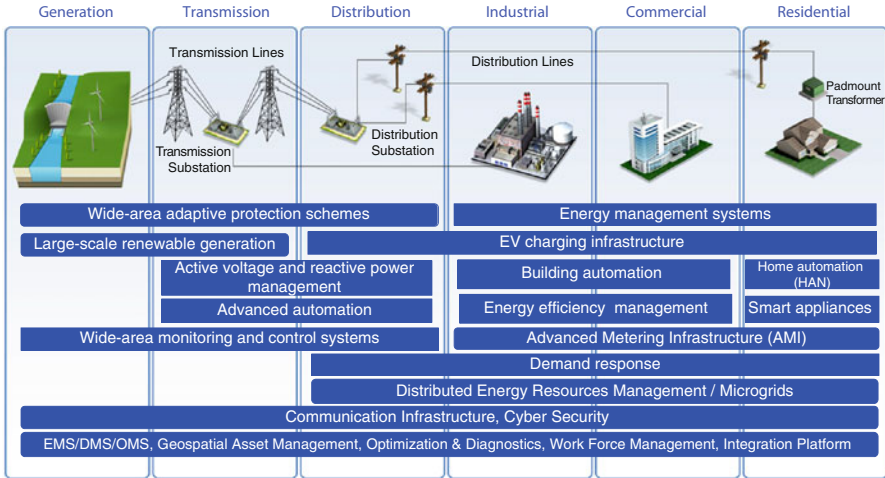

(Source: General Electric)

**Fig. 2.36** Smart Grid Technologies span across the entire electric grid (Source: General Electric)

conditioning (condition based monitoring); dynamic rating; advanced power electronics (e.g., flexible AC transmission system (FACTS), intelligent inverters, etc.), high temperature superconducting (HTS), and many others.

- *Grid-Enhanced Applications:* For example, distribution management systems (DMS); energy management systems (EMS); outage management systems (OMS); demand response (DR); advanced applications to enable active voltage and reactive power management (integrated voltage/VAR control (IVVC), coordinated voltage/VAR control (CVVC)); advanced analytics to support operational, non-operational and BI decision making; distributed energy resource management; microgrid and virtual power plant (VPP); work force management; geospatial asset management (geographic information system (GIS)); key performance indicator (KPI) dashboards and advanced visualization; and many others.
- *Customer:* For example, advanced metering infrastructure (AMI); home/building automation (home automation network (HAN)); energy management systems and display portals; electric vehicle (EV) charging stations; smart appliances, and many others.
- *Cyber Security and Data Privacy*
- *Communication and Integration Infrastructure*

### ***Distributed Generation Technology Landscape***

Common types of distributed generation include:

- Non-renewable generation:

- Combustion turbine generators
- Micro-turbines
- Internal combustion
- Small steam turbine units
- Renewable generation:
  - Low/high temperature fuel cells (e.g., alkaline fuel cell (AFC), molten carbonate fuel cell (MCFC), phosphoric acid fuel cell (PAFC), polymer electrolyte membrane fuel cell (PEMFC), solid oxide fuel cell (SOFC), direct methanol fuel cell (DMFC))
  - Photovoltaic (PV) (mono-, multicrystalline)
  - Concentrated PV (CPV)
  - Thin-film solar
  - Solar thermal
  - Hydro-electric (e.g., run-of-river)
  - Wind/mini-wind turbines
  - Tidal/wave
  - Ocean thermal energy conversion (OTEC) (e.g., land-, shelf-, floating-based plants, open, close, and hybrid cycles)
  - Energy storage (in the dispatch mode operations)

Each of these technologies is characterized by different electric efficiency, performance, installation footprint, and capital and operational costs.

### ***Demand-Response Design and Operational Challenges***

Demand-response (DR) interconnection engineering and engineering details depend on the specific installation size (kW vs. MW); however, the overall components of the installation should include the following:

- DG prime mover (or prime energy source) and its power converter
- Interface/step-up transformer
- Grounding (when needed – grounding type depends on utility-specific system requirements)
- Microprocessor protective relays for:
  - Three-, single-phase fault detection and DG overload (50, 51, 51V, 51N, 59N, 27N, 67)
  - Islanding and abnormal system conditions detection (81o/u, 81R, 27, 59)
  - Voltage and current unbalances detection (46, 47)
  - Undesirable reverse power detection (32)
  - Machine-based DG synchronization (25)
- Disconnect switches and/or switchgear(s)

**Table 2.3** DG interconnection requirements of utilities

Requirements	DG less than 10 kW	DG 10–100 kW	DG 100–1,000 kW	DG > 1,000 kW or >20% feeder load
Disconnect switch	Yes	Yes	Yes	Yes
Protective relays: islanding prevention and synchronization	Yes	Yes	Yes	Yes
Other protective relays (e.g., unbalance)	Optional	Optional	Yes	Yes
Dedicated transformer	Optional	Optional	Yes	Yes
Grounding impedance (due to ground fault contribution current)	No	No	Optional	Often
Special monitoring and control requirements	No	Optional	Yes	Yes
Telecommunication and transfer trip	No	Optional	Optional	Yes

- Metering, control, and data logging equipment
- Communication link(s) for transfer trip and dispatch control functions (when needed)

Table 2.3 summarizes the common DG interconnection requirements of utilities for various DG sizes (some details will vary based on utility-specific design and engineering practices).

### ***Demand-Response Integration and “Penetration” Level***

Integration of DG may have an impact on system performance. This impact can be assessed based on:

- Size and type of DG design: power converter type, unit rating, unit impedance, relay protection functions, interface transformer, grounding, etc.
- Type of DG prime mover: wind, PV, ICE (internal combustion engine), current transformer, etc.
- Interaction with other DG(s) or load(s)
- Location in the system and the characteristics of the grid, such as:
  - Network, auto-looped, radial, etc.
  - System impedance at connection point
  - Voltage control equipment types, locations, and settings
  - Grounding design
  - Protection equipment types, locations, and settings
  - Others

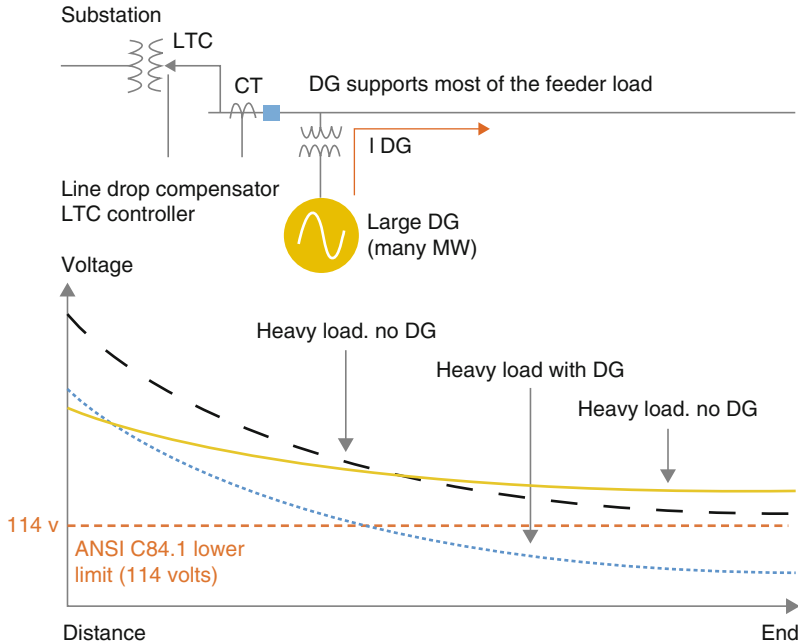

Fig. 2.37 DG connection close to the utility substation

DR system impact is also dependent on the “penetration” level of the DG connected to the grid. There are a number of factors that should be considered when evaluating the penetration level of DG in the system. Examples of DG penetration level factors include:

- DG as a percent of feeder or local interconnection point peak load (varies with location on the feeder)
- DG as a percent of substation peak load or substation capacity
- DG source fault current contribution as a percent of the utility source fault current (at various locations)

### ***Distributed Generation Impact on Voltage Regulation***

Voltage regulation, and in particular voltage rise effect, is a key factor that limits the amount (penetration level) of DG that can be connected to the system. Figure 2.37 shows an example of the network with a relatively large (MW size) DG interconnected at close proximity to the utility substation.

Careful investigation of the voltage profile indicates that during heavy-load conditions, with connected DG, voltage levels may drop below acceptable or permissible by standards. The reason for this condition is that relatively large DG reduces the circuit current value seen by the load tap changer (LTC) in the

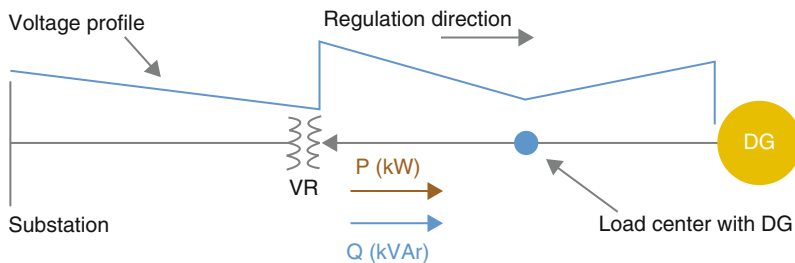

Fig. 2.38 VR bidirectional mode (normal flow)

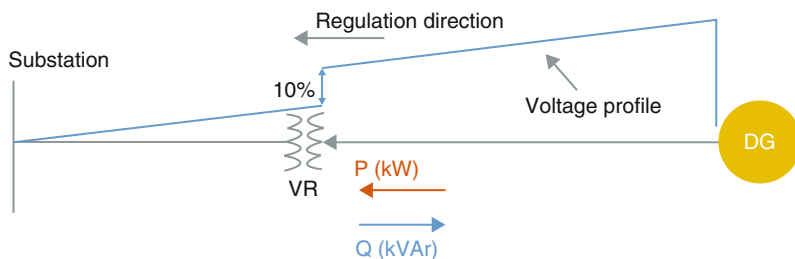

Fig. 2.39 VR bidirectional mode (reverse flow)

substation (DG current contribution). Since the LTC sees “less” current (representing a light load) than the actual value, it will lower the tap setting to avoid a “light-load, high-voltage” condition. This action makes the actual “heavy-load, low-voltage” condition worse. As a general rule, if the DG contributes less than 20% of the load current, then the DG current contribution effect will be minor and can probably be ignored in most cases.

Figures 2.38 and 2.39 show examples of the network with DG connected downstream from the bidirectional line voltage regulator (VR). During “normal” power flow conditions (Fig. 2.38), the VR detects the real power ( $P$ ) flow condition from the source (substation) toward the end of the circuit. The VR will operate in “forward” mode (secondary control). This operation is as planned, even though the “load center” has shifted toward the voltage regulator.

However, if the real power ( $P$ ) flow direction reverses toward the substation (Fig. 2.39), the VR will operate in the reverse mode (primary control). Since the voltage at the substation is a stronger source than the voltage at the DG (cannot be lowered by VR), the VR will increase the number of taps on the secondary side. Therefore, voltage on the secondary side increases dramatically.

### ***Distributed Generation Impact on Power Quality***

Two aspects of power quality are usually considered to be important during evaluation of DG impact on system performance: (1) voltage flicker conditions



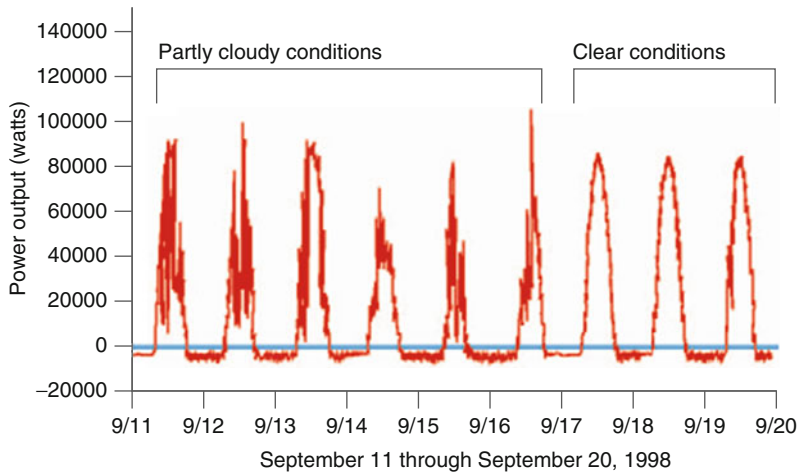

**Fig. 2.40** Power output fluctuation for 100 kW PV plant

and (2) harmonic distortion of the voltage. Depending on the particular circumstance, a DG can either decrease or increase the quality of the voltage received by other users of the distribution/medium-voltage network. Power quality is an increasingly important issue and generation is generally subject to the same regulations as loads. The effect of increasing the grid fault current by adding generation often leads to improved power quality; however, it may also have a negative impact on other aspects of system performance (e.g., protection coordination). A notable exception is that a single large DG, or aggregate of small DG connected to a “weak” grid may lead to power quality problems during starting and stopping conditions or output fluctuations (both normal and abnormal). For certain types of DG, such as wind turbines or PV, current fluctuations are a routine part of operation due to varying wind or sunlight conditions (Fig. 2.40).

Harmonics may cause interference with operation of some equipment, including overheating or de-rating of transformers, cables, and motors, leading to shorter life. In addition, they may interfere with some communication systems located in close proximity of the grid. In extreme cases they can cause resonant overvoltages, “blown” fuses, failed equipment, etc. DG technologies must comply with pre-specified by standards harmonic levels (Table 2.4).

In order to mitigate harmonic impact in the system, the following can be implemented:

- Use an interface transformer with a delta winding or ungrounded winding to minimize injection of triplen harmonics.
- Use a grounding reactor in neutral to minimize triplen harmonic injection.
- Specify rotating generator with 2/3 winding pitch design.
- Apply filters or use phase canceling transformers.

**Table 2.4** IEEE 519–1992, current distortion limits for general distribution systems

Maximum harmonic current distortion in % of $I_L$						
Individual harmonic order (odd harmonics)						
$I_{SC}/I_L$	<11	$11 \leq h < 17$	$17 \leq h < 23$	$23 \leq h < 35$	$35 \leq h$	TDD
<20 <sup>a</sup>	4.0	2.0	1.5	0.6	0.3	5.0
20 < 50	7.0	3.5	2.5	1.0	0.5	8.0
50 < 100	10.0	4.5	4.0	1.5	0.7	12.0
100 < 1,000	12.0	5.5	5.0	2.0	1.0	15.0
>1,000	15.0	7.0	6.0	2.5	1.4	20.0

Even harmonics are limited to 25% of the odd harmonic limits. TDD refers to total demand distortion and is based on the average maximum demand current at the fundamental frequency, taken at the PCC

$I_{SC}$  Maximum short circuit current at the PCC,  $I_L$  Maximum demand load current (fundamental) at the PCC,  $h$  Harmonic number

<sup>a</sup>All power generation equipment is limited to these values of current distortion regardless of  $I_{SC}/I_L$

- For inverters: Specify pulse width modulation (PWM) inverters with high switching frequency. Avoid line-commutated inverters or low switching frequency PWM; otherwise, more filters may be needed.
- Place DG at locations with high ratios of utility short-circuit current to DG rating.

### *Distributed Generation Impact on Ferroresonance*

Classic ferroresonance conditions can happen with or without interconnected DG (e.g., resonance between transformer magnetization reactance and underground cable capacitance on an open phase). However, by adding DG to the system, the case for overvoltage and resonance can increase for conditions such as: DG connected rated power is higher than the rated power of the connected load, presence of large capacitor banks (30–400% of unit rating), during DG formation on a non-grounded island.

### *DG Impact on System Protection*

Some DG will contribute current to a circuit current on the feeder. The current contribution will raise fault levels and in some cases may change fault current flow direction. The impact of DG fault current contributions on system protection coordination must be considered. The amount of current contribution, its duration, and whether or not there are protection coordination issues depend on:

- Size and location of DG on the feeder
- Type of DG (inverter, synchronous machine, induction machine) and its impedance

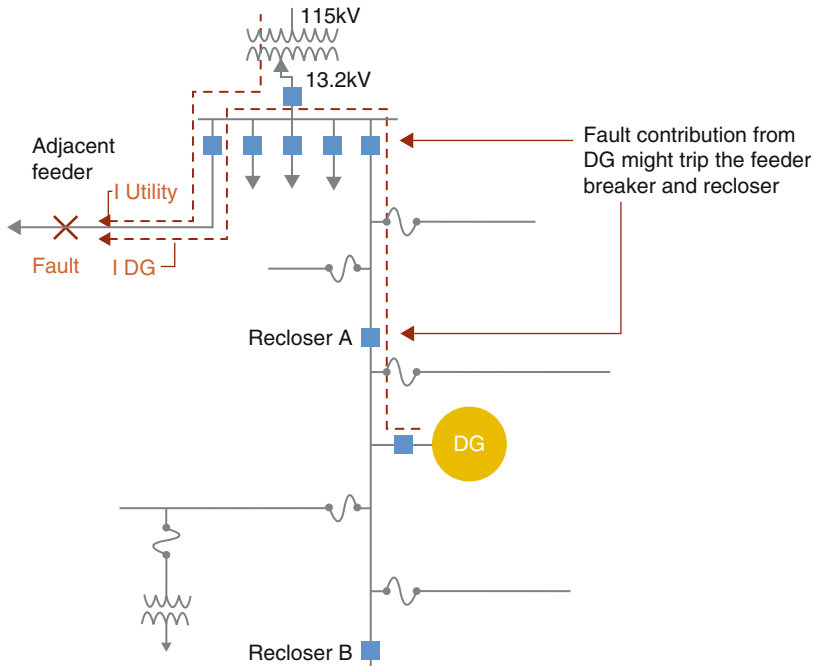

**Fig. 2.41** Undesirable protection trip (back-feeding)

- DG protection equipment settings (how fast it trips)
- Impedance, protection, and configuration of feeder
- Type of DG grounding and interface transformer

Machine-based DG (IEC, CT, some micro-turbines, and wind turbines) injects fault current levels of four to ten times their rated current with time contribution between 1/3 cycle and several cycles depending on the machine. Inverters contribute about one to two times their rated current to faults and can trip-off very quickly – many in less than one cycle under ideal conditions. Generally, if fault current levels are changed less than 5% by the DG, then it is unlikely that fault current contribution will have an impact on the existing system or equipment operation. Utilities must also consider interrupting capability of the equipment (e.g., circuit breakers, reclosers, and fuses must have sufficient capacity to interrupt the combined DG and utility source fault levels). Examples of DG fault contribution on system operation and possible protection mis-coordination are shown in Figs. 2.41 and 2.42.

## Future Directions

Today's distribution systems are becoming more and more complicated. New methods of producing and storing electrical energy such as PV, fuel cells, and battery storage systems and new methods of consuming electric energy such as

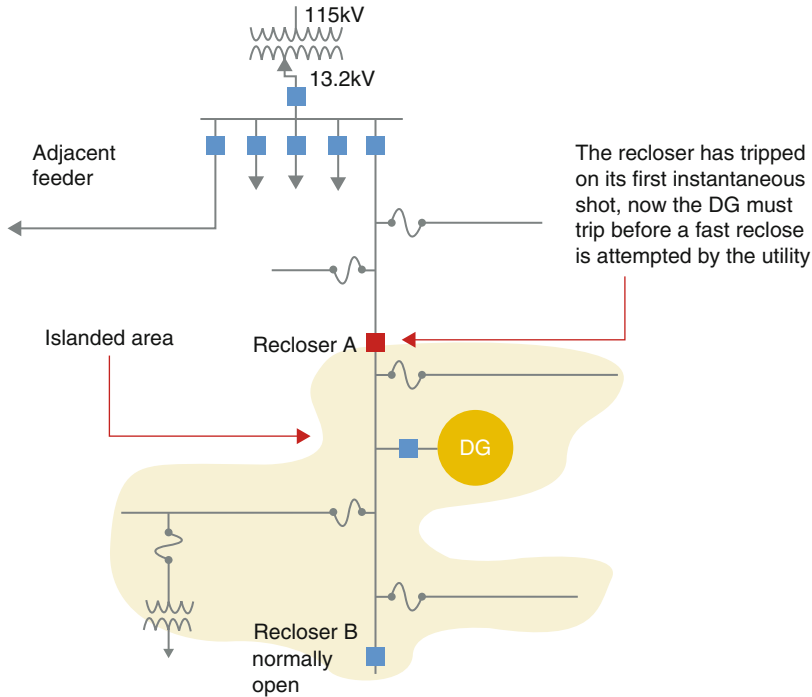

**Fig. 2.42** Unintentional DG Islanding

smart appliances and plug-in electric vehicles are being connected to the distribution grid. The rate of adoption of these devices will be driven faster as the economic and environmental benefits improve. In response, the automation systems used to monitor, control, and protect them will need to become more sophisticated.

Many utilities are facing these challenges today in increasingly larger areas of their distribution grid. Many developers are building new green communities that contain enough generation and storage to carry the community's load during an outage. Commonly referred to as microgrid operation, these areas of the distribution grid can be momentarily operated while isolated from the rest of main distribution grid. These microgrids can maintain service to un-faulted sections of the grid during some distribution outages. When these microgrids are connected to the distribution system, utilities are also investigating techniques to maximize the value of the distributed energy resources (DER) during times of economic peak or during capacity peaks. The electric energy in these devices can contribute watts, watt-hours, VARs, and voltage or frequency support during times of distribution system need.

The increasing complexity of the distribution grid will force a need to further integrate the various systems on that grid. The various systems described here will become increasingly integrated. These include the FDIR and Volt/VAR systems. As the FDIR system reconfigures the distribution system, the Volt/VAR system can then optimize the newly configured feeders. Information such as voltage and VARs from the

consumers can be used to improve the amount of the Volt/VAR system can control the grid without violating limits at the consumer. Microgrid operation will further push the integration of all of the distribution systems to maintain a safe, reliable, and efficient distribution grid.

This will have the effect of reducing the costs and increasing the overall benefits of these technologies, while maintaining an improved quality and reliability of the electric energy provided to the customers on the distribution system. This stronger economic justification will drive the rate of advance of these new technologies causing a significant impact on the issues and elements of the design of the distribution system and associated automation systems.

There are vast developments happening in the power industry changing whole transmission and distribution world including substations. Smart grid technologies make their way into transmission and distribution world to improve power supply, make it more efficient and reliable, and decrease greenhouse emissions. This became possible due to rapid developments in power electronics and communications. Major areas of developments are as follows:

- Smart metering implies getting metering data from all possible measurement points including end of the feeder over communications in order to maintain proper distribution voltage level for all consumers. This includes deploying voltage regulators, capacitor banks, switches, and other devices in the distribution network.
- Advances in communications imply real-time, live communication between the consumer, the network, and the generation station, so the utility can balance load demand in both directions. Advanced communications are also needed for manual or automatic reconfiguration of the network in case some components of the network are experiencing failures or deficiencies.
- Advanced protective relays and other control devices with enhanced communications and algorithms capabilities to automatically detect, isolate, and reconfigure the grid to maintain uninterrupted power supply.
- Renewable energy sources will continue fast deployment in the distribution network. Wind power, solar power, hydro power units will increase their capacity and output; energy storage systems will be deployed to help system to meet peak demand and offload system generators. Microgrids will provide consumers with reliable and high-quality energy when connection with a transmission system is lost or in case of isolated community.

A growing number of electric utilities worldwide are seeking ways to provide excellent energy services while becoming more customer focused, competitive, efficient, innovative, and environmentally responsible. Distributed generation is becoming an important element of the electric utility's smart grid portfolio in the twenty-first century. Present barriers to widespread implementation are being reduced as technologies mature and financial incentives (including government and investor supported funding) materialize. However, there are still technical challenges that need to be addressed and effectively overcome by utilities. Distributed generation should become part of a utility's day-to-day planning, design, and operational processes and practices, with special consideration given to:

- Transmission and distribution substation designs that are able to handle significant penetration of distributed generation
- Equipment rating margins for fault-level growth (due to added distributed generation)
- Protective relays and settings that can provide reliable and secure operation of the system with interconnected distributed generation (can handle multiple sources, reverse flow, variable fault levels, etc.)
- Feeder voltage regulation and voltage-drop design approaches that factor possible significant penetration of distributed generation
- Service restoration practices that reduce the chance of interference of distributed generation in the process and even take advantage of distributed generation to enhance reliability where possible
- Grounding practices and means to control distributed generation-induced ground-fault overvoltages.

## Bibliography

### *Primary Literature*

1. Smart Grids, European Union, <http://www.smartgrids.eu/>
2. United States Department of Energy, Office of Electric Transmission and Distribution (2003) Grid 2030: a national vision for electricity's second 100 years
3. EPRI (2009) Report to NIST on the smart grid's interoperability standards roadmap

### *Books and Reviews*

- Institute of Electrical and Electronics Engineers (1994) IEEE recommended practice for electric power distribution for industrial plants, IEEE Std 141-1993. Institute of Electrical and Electronics Engineers, New York. ISBN 978-1559373333
- Killian C, OG&E, Flynn B (2009) Justifying distribution automation at OG&E. In: 2009 DistribuTECH conference, San Diego, 3–5 Feb 2009
- Lathrop S, Flynn B, PacifiCorp (2006) Distribution automation pilot at PacifiCorp. In: Western Energy Institute, 2006 operations conference, Costa Mesa, 5–7 Apr 2006
- Lemke JW, Duke Energy, Flynn B (2009) Distributed generation, storage and the smart grid. In: Autovation 2009, The utilimetrics smart metering conference and exposition, Denver Colorado, 13–16 Sep 2009
- Stewart R, Flynn B, Pepco Holdings Incorporated (2007) Modeling DA improvements to reliability performance metrics. In: 2007 WPDAC, Spokane, Washington, DC, 3–5 Apr 2007
- Weaver T, AEP, Flynn B (2011) Achieving energy efficiency through distribution system improvements: integrated volt/VAR control (IVVC). In: 2011 DistribuTECH conference, San Diego, 3–5 Feb 2011
- Westinghouse Electric Corporation (1959) Electric utility engineering reference book, Distribution systems, vol 3. Westinghouse Electric Corporation, Pittsburgh