

THE EXPERT'S VOICE® IN F#

THIRD EDITION

# Expert F# 3.0

*TAKE YOUR PROGRAMMING SKILLS TO  
THE NEXT LEVEL THROUGH EFFICIENT,  
EXPRESSIVE, DATA-RICH FUNCTIONAL  
PROGRAMMING*

Don Syme, Adam Granicz and Antonio Cisternino

Apress®

# Expert F# 3.0



**Don Syme**  
**Adam Granicz**  
**Antonio Cisternino**

**Apress®**

### **Expert F# 3.0**

Copyright © 2012 by Don Syme, Adam Granicz, and Antonio Cisternino

This work is subject to copyright. All rights are reserved by the Publisher, whether the whole or part of the material is concerned, specifically the rights of translation, reprinting, reuse of illustrations, recitation, broadcasting, reproduction on microfilms or in any other physical way, and transmission or information storage and retrieval, electronic adaptation, computer software, or by similar or dissimilar methodology now known or hereafter developed. Exempted from this legal reservation are brief excerpts in connection with reviews or scholarly analysis or material supplied specifically for the purpose of being entered and executed on a computer system, for exclusive use by the purchaser of the work. Duplication of this publication or parts thereof is permitted only under the provisions of the Copyright Law of the Publisher's location, in its current version, and permission for use must always be obtained from Springer. Permissions for use may be obtained through RightsLink at the Copyright Clearance Center. Violations are liable to prosecution under the respective Copyright Law.

ISBN 978-1-4302-4650-3

ISBN 978-1-4302-4651-0 (eBook)

Trademarked names, logos, and images may appear in this book. Rather than use a trademark symbol with every occurrence of a trademarked name, logo, or image we use the names, logos, and images only in an editorial fashion and to the benefit of the trademark owner, with no intention of infringement of the trademark.

The use in this publication of trade names, trademarks, service marks, and similar terms, even if they are not identified as such, is not to be taken as an expression of opinion as to whether or not they are subject to proprietary rights.

While the advice and information in this book are believed to be true and accurate at the date of publication, neither the authors nor the editors nor the publisher can accept any legal responsibility for any errors or omissions that may be made. The publisher makes no warranty, express or implied, with respect to the material contained herein.

President and Publisher: Paul Manning

Lead Editors: Gwenan Spearing and Matthew Moodie

Technical Reviewer: Phil de Joux

Editorial Board: Steve Anglin, Ewan Buckingham, Gary Cornell, Louise Corrigan, Morgan Ertel,

Jonathan Gennick, Jonathan Hassell, Robert Hutchinson, Michelle Lowman, James Markham,

Matthew Moodie, Jeff Olson, Jeffrey Pepper, Douglas Pundick, Ben Renow-Clarke, Dominic

Shakeshaft, Gwenan Spearing, Matt Wade, Tom Welsh

Coordinating Editor: Mark Powers

Copy Editors: Pat Morris and Daryl Edelman

Compositor: Bytheway Publishing Services

Indexer: SPI Global

Artist: SPI Global

Cover Designer: Anna Ishchenko

Distributed to the book trade worldwide by Springer Science+Business Media New York, 233 Spring Street, 6th Floor, New York, NY 10013. Phone 1-800-SPRINGER, fax (201) 348-4505, e-mail orders-ny@springer-sbm.com, or visit [www.springeronline.com](http://www.springeronline.com).

For information on translations, please e-mail [rights@apress.com](mailto:rights@apress.com), or visit [www.apress.com](http://www.apress.com).

Apress and friends of ED books may be purchased in bulk for academic, corporate, or promotional use. eBook versions and licenses are also available for most titles. For more information, reference our Special Bulk Sales–eBook Licensing web page at [www.apress.com/bulk-sales](http://www.apress.com/bulk-sales).

Any source code or other supplementary materials referenced by the author in this text is available to readers at [www.apress.com/9781430246503](http://www.apress.com/9781430246503). For detailed information about how to locate your book's source code, go to [www.apress.com/source-code](http://www.apress.com/source-code).

*This book is dedicated to the memory of James Huddleston, the editor at Apress who initiated the first edition of Expert F# and encouraged the authors with his insights, loyalty, enthusiasm, and humor. Jim passed away in February 2007, an enormous loss to his family, Apress, and the authors.*

# Contents at a Glance

■ About the Authors .....	xx
■ About the Technical Reviewer .....	xxi
■ Acknowledgments.....	xxii
■ Chapter 1: Introduction .....	1
■ Chapter 2: Your First F# Program – Getting Started With F# .....	7
■ Chapter 3: Introducing Functional Programming.....	25
■ Chapter 4: Introducing Imperative Programming .....	49
■ Chapter 5: Understanding Types in Functional Programming.....	81
■ Chapter 6: Programming with Objects .....	111
■ Chapter 7: Encapsulating and Organizing Your Code .....	147
■ Chapter 8: Working with Textual Data .....	163
■ Chapter 9: Working with Sequences and Structured Data .....	189
■ Chapter 10: Numeric Programming and Charting.....	231
■ Chapter 11: Reactive, Asynchronous, and Parallel Programming .....	257
■ Chapter 12: Symbolic Programming with Structured Data .....	295
■ Chapter 13: Integrating External Data and Services .....	331
■ Chapter 14: Building Smart Web Applications .....	353
■ Chapter 15: Building Mobile Web Applications .....	391
■ Chapter 16: Visualization and Graphical User Interfaces .....	427
■ Chapter 17: Language-Oriented Programming: Advanced Techniques .....	477
■ Chapter 18: Libraries and Interoperating with Other Languages.....	503
■ Chapter 19: Packaging, Debugging and Testing F# Code .....	537
■ Chapter 20: Designing F# Libraries .....	565
Index .....	583

# Contents

■ <b>About the Authors</b> .....	<b>xx</b>
■ <b>About the Technical Reviewer</b> .....	<b>xxi</b>
■ <b>Acknowledgments</b> .....	<b>xxii</b>
■ <b>Chapter 1: Introduction</b> .....	<b>1</b>
The Genesis of F# .....	2
About This Book.....	2
Who This Book Is For .....	5
■ <b>Chapter 2: Your First F# Program – Getting Started With F#</b> .....	<b>7</b>
<b>Creating Your First F# Program</b> .....	<b>7</b>
Documenting Code .....	9
Using let.....	9
Understanding Types .....	10
Calling Functions .....	11
Lightweight Syntax .....	11
Understanding Scope .....	12
Using Data Structures.....	14
Using Properties and the Dot-Notation .....	14
Using Tuples .....	15
Using Imperative Code.....	17
<b>Using Object-Oriented Libraries from F#</b> .....	<b>18</b>
Using open to Access Namespaces and Modules .....	19
Using new and Setting Properties .....	20
Fetching a Web Page .....	22
<b>Summary</b> .....	<b>23</b>

<b>■ Chapter 3: Introducing Functional Programming</b> .....	<b>25</b>
<b>Starting with Numbers and Strings</b> .....	<b>25</b>
Some Simple Types and Literals.....	25
Arithmetic Conversions.....	26
Arithmetic Comparisons .....	27
Simple Strings .....	27
<b>Working with Conditionals: &amp;&amp; and   </b> .....	<b>28</b>
<b>Defining Recursive Functions</b> .....	<b>28</b>
<b>Lists</b> .....	<b>30</b>
<b>Options</b> .....	<b>33</b>
<b>Getting Started with Pattern Matching</b> .....	<b>34</b>
Matching on Structured Values.....	35
Guarding Rules and Combining Patterns.....	36
Further Ways of Forming Patterns.....	37
<b>Introducing Function Values</b> .....	<b>37</b>
Using Anonymous Function Values .....	39
Computing with Aggregate Operators .....	39
Composing Functions with >> .....	41
Building Functions with Partial Application .....	42
Using Local Functions.....	42
Iterating with Aggregate Operators .....	44
Abstracting Control with Functions .....	44
Using Object Methods as First-Class Functions .....	45
Some Common Uses of Function Values .....	45
<b>Summary</b> .....	<b>47</b>
<b>■ Chapter 4: Introducing Imperative Programming</b> .....	<b>49</b>
<b>About Functional and Imperative Programming</b> .....	<b>49</b>
<b>Imperative Looping and Iterating</b> .....	<b>50</b>
Simple for Loops.....	50
Simple While Loops .....	51
More Iteration Loops over Sequences .....	51
<b>Using Mutable Records</b> .....	<b>52</b>
Mutable Reference Cells.....	53
Avoiding Aliasing .....	54
Hiding Mutable Data.....	55

Using Mutable Locals .....	56
Working with Arrays .....	56
Generating and Slicing Arrays .....	58
Two-Dimensional Arrays.....	59
Introducing the Imperative .NET Collections .....	59
Using Resizable Arrays .....	59
Using Dictionaries.....	60
Using Dictionary's TryGetValue .....	61
Using Dictionaries with Compound Keys.....	62
Some Other Mutable Data Structures.....	62
Exceptions and Controlling Them .....	63
Catching Exceptions .....	64
Using try . . . finally.....	65
Defining New Exception Types.....	65
Having an Effect: Basic I/O .....	66
.NET I/O via Streams.....	67
Some Other I/O-Related Types.....	68
Using System.Console .....	69
Combining Functional and Imperative: Efficient Precomputation and Caching.....	69
Precomputation and Partial Application .....	69
Precomputation and Objects .....	70
Memoizing Computations .....	71
Lazy Values .....	74
Other Variations on Caching and Memoization.....	75
Combining Functional and Imperative: Functional Programming with Side Effects.....	75
Consider Replacing Mutable Locals and Loops with Recursion .....	76
Separating Pure Computation from Side-Effecting Computations .....	76
Separating Mutable Data Structures .....	76
Not All Side Effects Are Equal .....	77
Avoid Combining Imperative Programming and Laziness .....	78
Summary .....	79
■ Chapter 5: Understanding Types in Functional Programming.....	81
Exploring Some Simple Type Definitions .....	81
Defining Type Abbreviations .....	81
Defining Record Types .....	82
Handling Non-Unique Record Field Names .....	83



Cloning Records.....	84
Defining Discriminated Unions .....	84
Using Discriminated Unions as Records .....	86
Defining Multiple Types Simultaneously .....	87
<b>Understanding Generics .....</b>	<b>87</b>
Writing Generic Functions .....	88
Some Important Generic Functions .....	89
<b>Making Things Generic.....</b>	<b>94</b>
Generic Algorithms through Explicit Arguments .....	94
Generic Algorithms through Function Parameters.....	95
Generic Algorithms through Inlining .....	97
<b>More on Different Kinds of Types.....</b>	<b>99</b>
Reference Types and Value Types.....	99
Other Flavors of .NET Types.....	100
<b>Understanding Subtyping .....</b>	<b>100</b>
Casting Up Statically.....	101
Casting Down Dynamically .....	101
Performing Type Tests via Pattern Matching .....	102
Knowing When Upcasts Are Applied Automatically .....	102
Flexible Types .....	104
<b>Troubleshooting Type-Inference Problems .....</b>	<b>104</b>
Using a Visual Editing Environment .....	105
Using Type Annotations.....	105
Understanding the Value Restriction .....	106
Working Around the Value Restriction .....	107
Understanding Generic Overloaded Operators .....	109
<b>Summary .....</b>	<b>109</b>
<b>■ Chapter 6: Programming with Objects .....</b>	<b>111</b>
<b>Getting Started with Objects and Members .....</b>	<b>111</b>
<b>Using Classes .....</b>	<b>114</b>
<b>Adding Further Object Notation to Your Types .....</b>	<b>117</b>
Working with Indexer Properties .....	118
Adding Overloaded Operators.....	118
Using Named and Optional Arguments.....	120
Adding Method Overloading .....	121
<b>Defining Object Types with Mutable State.....</b>	<b>122</b>

Using Optional Property Settings.....	124
Declaring Auto-Properties .....	125
<b>Getting Started with Object Interface Types .....</b>	<b>126</b>
Defining New Object Interface Types.....	127
Implementing Object Interface Types Using Object Expressions .....	127
Implementing Object Interface Types Using Concrete Types .....	129
Using Common Object Interface Types from the .NET Libraries .....	129
Understanding Hierarchies of Object Interface Types.....	130
<b>More Techniques to Implement Objects .....</b>	<b>131</b>
Combining Object Expressions and Function Parameters .....	131
Defining Partially Implemented Class Types.....	133
Using Partially Implemented Types via Delegation .....	133
Using Partially Implemented Types via Implementation Inheritance .....	134
<b>Combining Functional and Objects: Cleaning Up Resources .....</b>	<b>135</b>
Resources and IDisposable .....	136
Managing Resources with More Complex Lifetimes .....	138
Cleaning Up Internal Objects .....	139
Cleaning Up Unmanaged Objects .....	140
<b>Extending Existing Types and Modules.....</b>	<b>141</b>
<b>Working with F# Objects and .NET Types .....</b>	<b>143</b>
Structs .....	144
Delegates.....	144
Enums.....	145
Working with null Values .....	145
<b>Summary .....</b>	<b>146</b>
<b>■ Chapter 7: Encapsulating and Organizing Your Code .....</b>	<b>147</b>
<b>Hiding Things .....</b>	<b>147</b>
Hiding Things with Local Definitions .....	148
Hiding Things with Accessibility Annotations .....	150
<b>Organizing Code with Namespaces and Modules .....</b>	<b>152</b>
Putting Your Code in a Module.....	153
Putting Your Modules and Types in Namespaces .....	153
Hiding Things with Signatures.....	154
Designing with Signatures .....	156
When Are Signature Types Checked? .....	156
Defining a Module with the Same Name as a Type .....	156

Preventing Client Code from Opening a Module .....	156
Using Files as Modules.....	157
Automatically Opening Modules .....	158
<b>Reusing Your Code.....</b>	<b>158</b>
Using Files as Small Reusable Components .....	159
Creating Assemblies, DLLs, and EXEs.....	159
Creating and Sharing Packages .....	161
<b>Summary .....</b>	<b>162</b>
<b>■ Chapter 8: Working with Textual Data .....</b>	<b>163</b>
<b>Building Strings and Formatting Data .....</b>	<b>163</b>
Building Strings .....	163
More about String Literals.....	164
Using printf and Friends .....	165
Generic Structural Formatting .....	167
Formatting Strings Using .NET Formatting.....	167
<b>Parsing Strings and Textual Data.....</b>	<b>168</b>
Parsing Basic Values .....	168
Processing Line-Based Input.....	169
Using Regular Expressions to Parse Lines .....	170
More on Matching with System.Text.RegularExpressions.....	171
Encoding and Decoding Unicode Strings.....	175
Encoding and Decoding Binary Data .....	176
<b>Using XML as a Concrete Language Format.....</b>	<b>176</b>
Using the System.Xml Namespace.....	176
From Concrete XML to Abstract Syntax.....	178
<b>Some Recursive Descent Parsing.....</b>	<b>180</b>
A Simple Tokenizer .....	181
Recursive-Descent Parsing .....	181
<b>Binary Parsing and Formatting .....</b>	<b>183</b>
<b>Summary .....</b>	<b>187</b>
<b>■ Chapter 9: Working with Sequences and Structured Data .....</b>	<b>189</b>
<b>Getting Started with Sequences.....</b>	<b>189</b>
Using Range Expressions .....	190
Iterating a Sequence .....	191
Transforming Sequences with Aggregate Operators.....	191
Which Types Can Be Used as Sequences? .....	192

Using Lazy Sequences from External Sources .....	192
Using Sequence Expressions.....	193
Enriching Sequence Expressions with Additional Logic .....	194
Generating Lists and Arrays Using Sequence Expressions .....	195
<b>More on Working with Sequences .....</b>	<b>196</b>
Using Other Sequence Operators: Truncate and Sort .....	197
Selecting Multiple Elements From Sequences .....	198
Finding Elements and Indexes in Sequences .....	199
Grouping and Indexing Sequences .....	200
Folding Sequences .....	201
Cleaning Up in Sequence Expressions .....	202
Expressing Some Operations Using Sequence Expressions.....	203
<b>Structure Beyond Sequences: Working with Trees .....</b>	<b>203</b>
Example: Abstract Syntax Representations .....	204
Transforming Abstract Syntax Representations.....	205
Using On-Demand Computation with Abstract Syntax Trees .....	206
Caching Properties in Abstract Syntax Trees .....	208
Memoizing Construction of Syntax Tree Nodes .....	208
<b>Active Patterns: Views for Structured Data .....</b>	<b>210</b>
Converting the Same Data to Many Views.....	211
Matching on .NET Object Types .....	213
Defining Partial and Parameterized Active Patterns.....	214
Hiding Abstract Syntax Implementations with Active Patterns.....	214
<b>Equality, Hashing, and Comparison for New Structured Data Types.....</b>	<b>216</b>
Equality, Hashing, and Comparison.....	216
Asserting Equality, Hashing, and Comparison Using Attributes .....	218
Fully Customizing Equality, Hashing, and Comparison on a Type .....	219
Suppressing Equality, Hashing, and Comparison on a Type .....	220
Customizing Generic Collection Types .....	221
<b>Tail Calls and Recursive Programming .....</b>	<b>222</b>
Tail Recursion and List Processing.....	223
Tail Recursion and Object-Oriented Programming .....	225
Tail Recursion and Processing Unbalanced Trees .....	226
Using Continuations to Avoid Stack Overflows .....	227
Another Example: Processing Syntax Trees.....	228
<b>Summary .....</b>	<b>230</b>

■ <b>Chapter 10: Numeric Programming and Charting</b> .....	<b>231</b>
<b>Basic Charting with FSharpChart</b> .....	<b>231</b>
<b>Basic Numeric Types and Literals</b> .....	<b>233</b>
Arithmetic Operators .....	234
Checked Arithmetic .....	234
Arithmetic Conversions.....	235
Arithmetic Comparisons .....	235
Overloaded Math Functions.....	236
Bitwise Operations .....	236
<b>Sequences, Statistics and Numeric Code</b> .....	<b>237</b>
Summing, Averaging, Maximizing and Minimizing Sequences.....	237
Counting and Categorizing .....	239
Writing Fresh Numeric Code.....	240
Making Numeric Code Generic .....	241
Example: KMeans .....	242
<b>Statistics, Linear Algebra and Distributions with Math.NET</b> .....	<b>244</b>
Basic Statistical Functions in Math.NET Numerics.....	245
Using Histograms and Distributions from Math.NET Numerics .....	246
Using Matrices and Vectors from Math.NET .....	248
Matrix Inverses, Decompositions and Eigenvalues.....	249
<b>Units of Measure</b> .....	<b>250</b>
Adding Units to a Numeric Algorithms.....	251
Adding Units to a Type Definition.....	253
Applying and Removing Units.....	254
Some Limitations of Units of Measure.....	254
<b>Summary</b> .....	<b>255</b>
■ <b>Chapter 11: Reactive, Asynchronous, and Parallel Programming</b> .....	<b>257</b>
<b>Introducing Some Terminology</b> .....	<b>258</b>
<b>Events</b> .....	<b>259</b>
Events as First-Class Values.....	260
Creating and Publishing Events.....	260
<b>Using and Designing Background Workers</b> .....	<b>262</b>
Building a Simpler Iterative Worker .....	264
Raising Additional Events from Background Workers.....	267
Connecting a Background Worker to a GUI.....	268

<b>Introducing Asynchronous and Parallel Computations .....</b>	<b>270</b>
Fetching Multiple Web Pages in Parallel, Asynchronously .....	270
Understanding Thread Hopping .....	272
Under the Hood: What Are Asynchronous Computations? .....	273
Parallel File Processing Using Asynchronous Workflows .....	275
Running Asynchronous Computations .....	278
Common I/O Operations in Asynchronous Workflows .....	279
Using Tasks with Asynchronous Programming .....	280
Understanding Exceptions and Cancellation .....	280
Under the Hood: Implementing Async.Parallel .....	281
Using async for CPU Parallelism with Fixed Tasks .....	282
<b>Agents .....</b>	<b>282</b>
Introducing Agents .....	283
Creating Objects That React to Messages .....	284
Scanning Mailboxes for Relevant Messages .....	286
Example: Asynchronous Web Crawling .....	287
<b>Observables .....</b>	<b>290</b>
<b>Using Shared-Memory Concurrency .....</b>	<b>290</b>
Creating Threads Explicitly .....	291
Shared Memory, Race Conditions, and the .NET Memory Model .....	291
Using Locks to Avoid Race Conditions .....	292
Using ReaderWriterLock .....	293
Some Other Concurrency Primitives .....	294
<b>Summary .....</b>	<b>294</b>
<b>■ Chapter 12: Symbolic Programming with Structured Data .....</b>	<b>295</b>
<b>Verifying Circuits with Propositional Logic .....</b>	<b>295</b>
Representing Propositional Logic .....	296
Evaluating Propositional Logic Naively .....	298
From Circuits to Propositional Logic .....	300
Checking Simple Properties of Circuits .....	303
Representing Propositional Formulae Efficiently Using BDDs .....	303
Circuit Verification with BDDs .....	307
<b>Symbolic Differentiation and Expression Rendering .....</b>	<b>309</b>
Modeling Simple Algebraic Expressions .....	310
Implementing Local Simplifications .....	312
A Richer Language of Algebraic Expressions .....	313

Parsing Algebraic Expressions .....	315
Simplifying Algebraic Expressions.....	317
Symbolic Differentiation of Algebraic Expressions .....	319
Rendering Expressions .....	320
Building the User Interface .....	327
Summary .....	329
<b>■ Chapter 13: Integrating External Data and Services .....</b>	<b>331</b>
Some Basic REST Requests .....	332
Getting Data in JSON Format.....	333
Parsing the XML or JSON Data .....	333
Handling Multiple Pages.....	334
Getting Started with Type Providers and Queries .....	335
Example - Language Integrated OData.....	335
What is a Type Provider? .....	336
What is a Query? .....	337
Handling Pagination in OData.....	339
Example - Language Integrated SQL .....	340
More on Queries .....	341
Sorting .....	342
Aggregation .....	342
Nullables.....	343
Inner Queries .....	343
Grouping .....	344
Joins .....	344
More on Relational Databases and ADO.NET .....	345
Establishing Connections using ADO.NET .....	347
Creating a Database using ADO.NET.....	348
Creating Tables using ADO.NET.....	348
Using Stored Procedures via ADO.NET.....	350
Using WSDL Services .....	351
Summary .....	352
<b>■ Chapter 14: Building Smart Web Applications .....</b>	<b>353</b>
Serving Web Content the Simple Way .....	353
Building Ajax Rich Client Applications .....	358
Learning More from the WebSharper Documentation .....	359
Getting Started with WebSharper .....	360

Calling Server Code from the Client .....	362
WebSharper Sitelets .....	363
Online vs. Offline Sitelets .....	364
Serving Content from WebSharper Sitelets .....	365
Using Dynamic Templates .....	367
Embedding Client-Side Controls in Sitelet Pages .....	368
Constructing and Combining Sitelets .....	369
Sitelet Routers and Controllers .....	372
Constructing Sitelets for Handling Non-GET HTTP Commands .....	372
WebSharper Formlets .....	379
Dependent Formlets and Flowlets .....	387
Automated Resource Tracking and Handling .....	387
Using Third-Party JavaScript Libraries .....	388
Working with .NET Proxies .....	389
<b>Summary .....</b>	<b>390</b>
<b>■ Chapter 15: Building Mobile Web Applications .....</b>	<b>391</b>
Web-based vs. Native Mobile Applications .....	391
Feature Detection and Polyfilling in WebSharper .....	393
Mobile Capabilities, Touch Events, and Mobile Frameworks .....	395
Serving Mobile Content .....	397
Building a Mobile Web Application for iOS Devices .....	398
Fleshing Out the Application .....	399
Digging Deeper .....	404
Developing Social Networking Applications .....	406
Configuring Your New Facebook Application .....	409
Defining the Main HTML Application .....	410
WebSharper Mobile .....	415
Developing Android Applications with WebSharper .....	417
Setting Up and Testing with Your Android Environment .....	418
Using the Android Application Visual Studio Template .....	420
Implementing Your Native Android Application .....	421
<b>Summary .....</b>	<b>426</b>
<b>■ Chapter 16: Visualization and Graphical User Interfaces .....</b>	<b>427</b>
Writing “Hello, World!” in a Click .....	427
Understanding the Anatomy of a Graphical Application .....	428



Composing User Interfaces .....	429
Drawing Applications.....	433
Writing Your Own Controls.....	438
Developing a Custom Control .....	438
Anatomy of a Control .....	441
Displaying Samples from Sensors.....	441
Building the GraphControl: The Model .....	443
Building the GraphControl: Style Properties and Controller .....	445
Building the GraphControl: The View .....	449
Putting It Together .....	453
Creating a Mandelbrot Viewer .....	454
Computing Mandelbrot .....	454
Setting Colors .....	455
Creating the Visualization Application .....	457
Creating the Application Plumbing .....	460
Windows Presentation Foundation .....	465
When GUIs Meet the Web .....	466
Drawing .....	468
Controls .....	471
Bitmaps and Images.....	474
Final Considerations .....	476
Summary .....	476
<b>■ Chapter 17: Language-Oriented Programming: Advanced Techniques .....</b>	<b>477</b>
Computation Expressions .....	478
An Example: Success/Failure Workflows.....	480
Defining a Workflow Builder .....	483
Workflows and Untamed Side Effects .....	485
Computation Expressions with Custom Query Operators .....	486
Example: Probabilistic Workflows.....	487
Combining Workflows and Resources .....	492
Recursive Workflow Expressions.....	492
Using F# Reflection .....	492
Reflecting on Types.....	493
Schema Compilation by Reflecting on Types .....	493
Using the F# Dynamic Reflection Operators .....	497
Using F# Quotations .....	498

Example: Using F# Quotations for Error Estimation .....	499
Resolving Reflected Definitions .....	501
Summary .....	501
■ <b>Chapter 18: Libraries and Interoperating with Other Languages .....</b>	<b>503</b>
Types, memory and interoperability .....	503
Libraries: A High-Level Overview.....	504
Namespaces from the .NET Framework.....	505
Namespaces from the F# Libraries.....	507
Using the System Types .....	508
Using Further F# and .NET Data Structures.....	508
System.Collections.Generic and Other .NET Collections .....	509
Supervising and Isolating Execution .....	509
Further Libraries for Reflective Techniques.....	510
Using General Types .....	510
Using Microsoft.FSharp.Reflection .....	511
Some Other .NET Types You May Encounter.....	511
Under the Hood: Interoperating with C# and other .NET Languages .....	512
The Common Language Runtime .....	512
Memory Management at Runtime .....	514
COM Interoperability.....	516
Calling COM Components from F#.....	516
The Running Object Table .....	521
Interoperating with C and C++ with PInvoke .....	522
Getting Started with PInvoke .....	523
Mapping C Data Structures to F# Code .....	525
Marshalling Parameters to and from C.....	526
Marshalling Strings to and from C.....	528
Passing Function Pointers to C.....	530
PInvoke Memory Mapping.....	531
Wrapper Generation and Limits of PInvoke .....	534
Summary .....	535
■ <b>Chapter 19: Packaging, Debugging and Testing F# Code .....</b>	<b>537</b>
Packaging Your Code .....	537
Mixing Scripting and Compiled Code.....	537
Choosing Optimization Settings.....	538

Generating Documentation .....	539
Building Shared Libraries .....	539
Using Static Linking.....	541
Packaging Different Kinds of Code .....	541
Using Data and Configuration Settings.....	542
<b>Debugging Your Code .....</b>	<b>543</b>
Using More Features of the Visual Studio Debugger .....	546
Instrumenting Your Program with the System.Diagnostics Namespace .....	548
Debugging Concurrent and Graphical Applications .....	551
<b>Debugging and Testing with F# Interactive .....</b>	<b>553</b>
Controlling F# Interactive .....	553
Some Common F# Interactive Directives.....	554
Understanding How F# Interactive Compiles Code.....	555
F# Interactive and Visual Studio .....	556
<b>Testing Your Code .....</b>	<b>557</b>
<b>Summary .....</b>	<b>563</b>
<b>■ Chapter 20: Designing F# Libraries .....</b>	<b>565</b>
Designing Vanilla .NET Libraries.....	566
Understanding Functional Design Methodology.....	571
Understanding Where Functional Programming Comes From.....	571
Understanding Functional Design Methodology .....	572
Applying the .NET Library Design Guidelines to F# .....	574
Recommendation: Use the .NET Naming and Capitalization Conventions Where Possible .....	574
Recommendation: Avoid Using Underscores in Names .....	576
Recommendation: Follow the .NET Guidelines for Exceptions .....	577
Recommendation: Consider Using Option Values for Return Types Instead of Raising Exceptions .....	577
Recommendation: Follow the .NET Guidelines for Value Types .....	577
Recommendation: Consider Using Explicit Signature Files for Your Framework.....	578
Recommendation: Consider Avoiding the Use of Implementation Inheritance for Extensibility .....	578
Recommendation: Use Properties and Methods for Attributes and Operations Essential to a Type .....	578
Recommendation: Avoid Revealing Concrete Data Representations Such as Records .....	579
Recommendation: Use Active Patterns to Hide the Implementations of Discriminated Unions.....	579
Recommendation: Use Object Interface Types Instead of Tuples or Records of Functions.....	579
Recommendation: Understand When Currying Is Useful in Functional Programming APIs .....	579
Recommendation: Use Tuples for Return Values, Arguments, and Intermediate Values .....	580

**Some Recommended Coding Idioms.....580**

    Recommendation: Use the Standard Operators.....581

    Recommendation: Place the Pipeline Operator |> at the Start of a Line.....581

    Recommendation: Format Object Expressions Using the member Syntax.....581

**Summary.....582**

**Index .....583**

# About the Authors



■ **Don Syme** is a principal researcher at Microsoft Research, and the main designer of F#. Since joining Microsoft Research in 1998, he has been a seminal contributor to a wide variety of leading-edge projects, including generics in C# and the .NET Common Language Runtime, F# itself, F# asynchronous programming, and units of measure in F#. He received a Ph.D. from the University of Cambridge Computer Laboratory in 1999.



■ **Adam Granicz** is the chief executive officer of IntelliFactory, the leading provider of F# training, development and consulting services, and technologies that enable rapid functional, reactive web development. He has over eight years of experience applying F# in commercial projects, and works on WebSharper, IntelliFactory's web development platform that offers unrivaled productivity, a uniform programming model based on F#, and the fastest way to develop robust, client-based rich Internet and mobile applications. Adam is an active F# evangelist, a regular F# author and speaker at development conferences and workshops, and serves on the steering committee of the Commercial Users of Functional Programming (CUFP) Workshop, representing the F# segment.



■ **Antonio Cisternino** is assistant professor in the computer science department of the University of Pisa, Italy. His primary research is on meta-programming and domain-specific languages on virtual-machine-based execution environments. He has been active in the .NET community since 2000. He recently developed VSLab, a Visual Studio add-in designed to add the ability of creating dynamic tool-windows, and he also contributed to the development of Octopus, a scheduler of virtual machines running on Hyper-V. He teaches F# in the Programming Graphical Interfaces course at the University of Pisa. Antonio has a Ph.D. in computer science from the University of Pisa.

# About the Technical Reviewer



■ **Phil de Joux** was a child math whiz, dirtbag climber, and bicycle messenger. His medical studies went asymptotic, and his eventual degree was in mathematical modeling. Like many kiwis, he left his native New Zealand islands to see a bit more of the world, and worked as a contracting software developer in England and France, financing a few long road trips rock climbing in the United States and Australia.

On return to New Zealand in 2003, he formed his company, Block Scope, named in allusion to the scoping rule, how contractors are hired for defined blocks of work, and for bouldering, a form of rock climbing where finding new problems involves scoping new lines on the rocks. He has used F# on commercial projects, analyzing time series data in the REPL, pulling in web services with type providers, and distributing messages with mailbox processors.

In Australia since the earthquakes hit his home town of Christchurch, he is learning a slew of functional programming languages and enjoying meetups with the Brisbane Functional Programming Group.

# Acknowledgments

We would like to thank Dominic Shakeshaft, Gwenan Spearing, Matt Moodie, and Mark Powers from Apress, who have worked with us and kept us on track for publication. Likewise, we thank Phil de Joux, who acted as technical reviewer and whose comments were invaluable in ensuring that the book is a comprehensive and reliable source of information.

The drafts and first two editions of this book were read and commented on by many people, and *Expert F# 3.0* has benefited greatly from their input. In particular, we would like to thank Ashley Feniello, whose meticulous reviews proved invaluable, as well as John Bates, Nikolaj Bjorner, Luca Bolognese, Laurent le Brun, Richard Black, Chris Brumme, Andrew Herbert, Ralf Herbrich, Luke Hoban, Jason Hogg, Anders Janmyr, Paulo Janotti, Pouya Larjani, Julien Laugel, Richard Mortier, Enrique Nell, Gregory Neverov, Raj Pai, Ravi Pandya, Phil Trelford, Dave Waterworth, Dave Wecker, and Onno Zoeter, to name but a few.

We also thank Microsoft Research, without which neither F# nor this book would have been possible, and we are very grateful for the interactions, help, and support given by other researchers and language designers, including Byron Cook, Anders Hejlsberg, Xavier Leroy, Simon Marlow, Erik Meijer, Malcolm Newey, Martin Odersky, Simon Peyton Jones, Mads Torgersen, and Phil Wadler. Finally, we thank our families and loved ones for their long-suffering patience. It would have been impossible to complete this book without their unceasing support.

## CHAPTER 1



# Introduction

F# is a strongly-typed functional programming language designed to empower programmers and domain experts to write simple, robust code to solve complex problems. It combines the succinctness, expressivity, efficiency, and compositionality of typed functional programming with the runtime support, libraries, interoperability, tools, and object models of modern programming frameworks. The aim of this book is to help you become an expert in using F# for a range of practical programming problems.

Functional programming has long inspired researchers, students, and programmers alike with its simplicity and expressive power. Applied functional programming is booming: a new generation of typed functional languages is reaching maturity; some functional language constructs have been integrated into languages such as C#, Python, and Visual Basic; and there is now a widespread expertise available in the pragmatic application of functional programming techniques. There is also strong evidence that functional programming offers significant productivity gains in important application areas such as data access, financial modeling, statistical analysis, machine learning, software verification, and bio-informatics. More recently, functional programming is part of the rise of declarative programming models, especially in the data query, concurrent, reactive, and parallel programming domains.

F# is a “functional-first” language, where functional programming is the first option used for solving most programming problems. However, F# differs from many functional languages in that it embraces imperative and object-oriented (OO) programming where necessary. It also provides a missing link between compiled and dynamic languages, allowing the idioms and programming styles typical of dynamic languages while preserving the performance and robustness of a strongly-typed compiled language. The F# designers have adopted a design philosophy that allows you to take the best and most productive aspects of these paradigms and combine them while still placing primary emphasis on simple functional programming techniques. This book helps you understand the power that F# offers through this combination.

F# offers an approach to computing that will continue to surprise and delight, and mastering functional programming techniques will help you become a better programmer regardless of the language you use. There has been no better time to learn functional programming, and F# offers the best route to learn and apply functional programming to solve real-world problems.

Although F# is an open-source language under an OSS-approved license, supported tooling for F# is available from Microsoft through tools such as Visual Studio 2010 and Visual Studio 2012, making functional programming a viable choice for many mainstream and professional programming activities. F# also has a vibrant community, contributing projects for using F# on a wide range of platforms, and contributing an ecosystem of supporting commercial and open-source components and tools. The designer of the F# language, Don Syme, is one of the authors of this book. This book benefits from his authority on F# and .NET and from all the authors’ years of experience with F# and other programming languages.



## The Genesis of F#

F# began in 2002, when Don Syme and others at Microsoft Research decided to ensure that the ML approach to pragmatic but theoretically based language design found a high-quality expression for the .NET platform. The project was closely associated with the design and implementation of Generics for the .NET Common Language Runtime. The first stabilized, supported version of F# was F# 2.0, included with Visual Studio 2010. In 2012, Microsoft released F# 3.0. This is the version of the language described in this book and is also the version included with Visual Studio 2012.

F# shares a core language with the programming language OCaml, which in turn comes from the ML family of programming languages, which dates back to 1974. F# also draws from Haskell, particularly with regard to two language features: sequence expressions and workflows.

Despite the similarities to OCaml and Haskell, programming with F# is quite different in practice. In particular, the F# approach to OO programming, and dynamic language techniques is substantially different from other mainstream functional languages. Programming in F# tends to be more object-oriented than in other functional languages. Programming also tends to be more flexible, as F# embraces techniques such as dynamic loading, dynamic typing, and reflection, and it adds techniques such as expression quotation, units-of-measure, type providers and active patterns. We cover these topics in this book and use them in many application areas.

F# also owes a lot to the designers of .NET, whose vision of language interoperability between C++, Visual Basic, and the language that eventually became C# is still shaping the computer industry. Today, F# draws much from the broader community around the Common Language Infrastructure (CLI), implemented by the Microsoft .NET Framework and Mono. F# is able to leverage libraries and techniques developed by Microsoft, the broader .NET community, the highly active open source community centered around Mono, and open source and cross-platform implementation of the ECMA CLI standard that works well on Windows, Mac, and Linux environments. Mono can also be used to author applications for the Android and Apple iOS platforms. F# code can also be edited and executed directly in most web browsers through sites such as [www.tryfsharp.org](http://www.tryfsharp.org). F# 3.0 can be compiled to Javascript through the open-source community project Pit and the professional open-source product WebSharper, [www.websharper.com](http://www.websharper.com).

## About This Book

This book is structured in three parts. Chapters 2 to 11 deal with the F# language and basic techniques such as functional, imperative and object-oriented programming, techniques to program with textual, structured and numeric data, and techniques for parallel, reactive and concurrent programming. Chapters 12 to 20 deal with a series of applied programming samples and topics ranging from building applications to software engineering and design issues.

Throughout this book, we address both *programming constructs* and *programming techniques*. Our approach is driven by examples: we show code, and then we explain it. Frequently, we give reference material describing the constructs used in the code and related constructs you may use in similar programming tasks. We've found that an example-driven approach helps bring out the essence of a language and how the language constructs work together. You can find a complete syntax guide in the appendix, and we encourage you to reference it while reading the book.

The book's chapters are as follows, starting with basic F# techniques:

Chapter 2, "Your First F# Program – Getting Started With F#," begins by introducing F# Interactive, a tool you can use to interactively evaluate F# expressions and declarations and that we encourage you to use while reading this book. In this chapter, you use F# Interactive to explore some basic F# and .NET constructs, and we introduce many concepts that are described in more detail in later chapters.

Chapter 3, “Introducing Functional Programming,” focuses on the basic constructs of typed functional programming, including arithmetic and string primitives, type inference, tuples, lists, options, function values, aggregate operators, recursive functions, function pipelines, function compositions, and pattern matching.

Chapter 4, “Introducing Imperative Programming,” introduces the basic constructs used for imperative programming in F#. Although the use of imperative programming is often minimized with F#, it’s used heavily in some programming tasks such as scripting. You learn about loops, arrays, mutability mutable records, locals and reference cells, the imperative .NET collections, exceptions, and the basics of .NET I/O.

Chapter 5, “Understanding Types in Functional Programming,” covers types in more depth, especially the more advanced topics of generic type variables and subtyping. You learn techniques that you can use to make your code generic and how to understand and clarify type error messages reported by the F# compiler.

Chapter 6, “Programming with Objects,” introduces object-oriented programming in F#. You learn how to define concrete object types to implement data structures, how to use OO notational devices such as method overloading with your F# types, and how to create objects with mutable state. You then learn how to define object interface types and a range of techniques to implement objects, including object expressions, constructor functions, delegation, and implementation inheritance.

Chapter 7, “Encapsulating and Organizing Your Code,” shows the techniques you can use to hide implementation details through encapsulation and to organize your code with namespaces and modules.

Chapter 8, “Working with Textual Data,” looks at techniques for formatting data, working with strings, JSON and XML, tokenizing text, parsing text, and marshaling binary values.

Chapter 9, “Working with Sequences and Structured Data,” looks at two important sets of functional programming techniques. In this chapter, you learn succinct and compositional techniques for building, transforming, and querying in-memory data structures and sequences. In addition, you learn techniques for working with tree-structured data, especially abstract syntax representations, how to use F# active patterns to hide representations, and how to traverse large structured data without causing stack overflows through the use of tail calls.

Chapter 10, “Numeric Programming and Charting,” looks at constructs and libraries for programming with numerical data in F#. In this chapter, you learn about basic numeric types, how to use library routines for summing, aggregating, maximizing and minimizing sequences, how to implement numeric algorithms, how to use the FSharpChart library for charting, how to use units of measure in F# to give strong typing to numeric data, and how to use the powerful open source Math.NET library for advanced vector, matrix, statistical, and linear-algebra programming.

Chapter 11, “Reactive, Asynchronous, and Parallel Programming,” shows how you can use F# for programs that have multiple logical threads of execution and that react to inputs and messages. You first learn how to construct basic background tasks that support progress reporting and cancellation. You then learn how to use F# asynchronous workflows to build scalable, massively concurrent reactive programs that make good use of the .NET thread pool and other .NET concurrency-related resources. This chapter concentrates on message-passing techniques that avoid or minimize the use of shared memory. However, you also learn the fundamentals of concurrent programming with shared memory using .NET.

Chapters 12 to 20 deal with applied topics in F# programming.

Chapter 12, “Symbolic Programming with Structured Data,” applies some of the techniques from Chapters 9 and 11 in two case studies. The first is symbolic expression differentiation and rendering, an extended version of a commonly used case study in symbolic programming. The second is verifying circuits with propositional logic; you learn how to use symbolic techniques to represent digital circuits, specify properties of these circuits, and verify these properties using binary decision diagrams (BDDs).

Chapter 13, “Integrating External Data and Services,” looks at several dimensions of querying and accessing data from F#. You first learn how to use the type provider feature of F# 3.0 to give fluent data scripting against databases and web services. You then learn how to use queries with F#, in particular the LINQ paradigm supported by .NET. You then look at how to use F# in conjunction with relational databases, particularly through the use of the ADO.NET and LINQ-to-SQL technologies that are part of the .NET Framework.

Chapter 14, “Build Smart Web Applications,” shows how to use F# with ASP.NET to write server-side scripts that respond to web requests. You learn how to serve web-page content using ASP.NET controls. We also describe how projects such as the WebSharper Platform let you write HTML5 Web Applications in F#.

Chapter 15, “Building Mobile Web Applications,” shows how to use the WebSharper framework to build web applications customized for mobile devices. In this chapter, you learn how you can serve mobile web content from your WebSharper applications, how you can use feature detection and polyfilling libraries in your applications to work around mobile browser limitations and missing features, how you can develop WebSharper applications for iOS that use platform-specific markup to access unique features such as multi-touch events, how you can develop WebSharper applications that use the Facebook API, how you can use WebSharper Mobile to create native Android and Windows Phone packages for your WebSharper applications, and how you can integrate mobile formlets and Bing Maps in a WebSharper application.

Chapter 16, “Visualization and Graphical User Interfaces,” shows how to design and build graphical user interface applications using F# and the .NET Windows Forms and WPF libraries. We also show how to design new controls using standard OO design patterns and how to script applications using the controls offered by the .NET libraries directly.

Chapter 17, “Language-Oriented Programming: Advanced Techniques,” looks at what is effectively a fourth programming paradigm supported by F#: the manipulation and representation of languages using a variety of concrete and abstract representations. In this chapter, you learn three advanced features of F# programming: F# computation expressions (also called workflows), F# reflection, and F# quotations. These are also used in other chapters, particularly Chapters 13 and 15.

Chapter 18, “Libraries and Interoperating with Other Languages,” shows how to use F# with other software libraries. In particular, you learn how to use F# with .NET libraries and look at some of the libraries available. You also learn how to interoperate C# code with COM, learn more about the .NET Common Language Runtime, look at how memory management works, and learn how to use the .NET Platform Invoke mechanisms from F#.

Chapter 19, “Packaging, Debugging and Testing F# Code,” shows the primary tools and techniques you can use to eliminate bugs from your F# programs. You learn how to package your code into .NET assemblies, learn about other package sharing techniques, learn how to use the .NET and Visual Studio debugging tools with F#, how to use F# Interactive for exploratory development and testing, and how to use the NUnit testing framework with F# code.

Chapter 20, “Designing F# Libraries,” gives our advice on methodology and design issues for writing libraries in F#. You learn how to write vanilla .NET libraries that make relatively little use of F# constructs at their boundaries in order to appear as natural as possible to other .NET programmers. We then cover functional programming design methodology and how to combine it with the OO design techniques specified by the standard .NET Framework design guidelines.

The appendix, “F# Brief Language Guide,” gives a compact guide to all key F# language constructs and the key operators used in F# programming.

Because of space limitations, we only partially address some important aspects of programming with F#. There are also hundreds of open-source projects related to .NET programming, many with a specific focus on F#. F# can also be used with alternative implementations of the CLI such as Mono, topics we address only tangentially in this book. Quotation meta-programming is described only briefly in Chapter 16, and some topics in functional programming such as the design and implementation of applicative data structures aren’t covered at all. We do not describe how to create new instances of the F# 3.0 feature called “type providers” because excellent material on authoring type providers is available from Microsoft. Also, some software engineering issues such as performance tuning are largely omitted.

## Who This Book Is For

We assume you have some programming knowledge and experience. If you don’t have experience with F#, you’ll still be familiar with many of the ideas it uses. However, you may also encounter some new and challenging ideas. For example, if you’ve been taught that OO design and programming are the only ways to think about software, then programming in F# may be a re-education. F# fully supports OO development, but F# programming combines elements of both functional and OO design. OO patterns such as implementation inheritance play a less prominent role than you may have previously experienced. Chapter 6 covers many of these topics in depth.

The following notes will help you set a path through this book, depending on your background:

*C++, C#, Java, and Visual Basic:* If you've programmed in a typed OO language, you may find that functional programming, type inference, and F# type parameters take a while to get used to. However, you'll soon see how to use these to be a more productive programmer. Be sure to read Chapters 2, 3, 5, and 6 carefully.

*Python, Scheme, Ruby, and dynamically typed languages:* F# is statically typed and type-safe. As a result, F# development environments can discover many errors while you program, and the F# compiler can more aggressively optimize your code. If you've primarily programmed in an untyped language such as Python, Scheme, or Ruby, you may think that static types are inflexible and wordy. However, F# static types are relatively nonintrusive, and you'll find the language strikes a balance between expressivity and type safety. You'll also see how type inference lets you recover succinctness despite working in a statically typed language. Be sure to read Chapters 2 to 6 carefully, paying particular attention to the ways in which types are used and defined.

*Typed functional languages:* If you're familiar with Haskell, OCaml, or Standard ML, you'll find the core of F# readily familiar, with some syntactic differences. However, F# embraces .NET, including the .NET object model, and it may take you awhile to learn how to use objects effectively and how to use the .NET libraries themselves. This is best done by learning how F# approaches OO programming in Chapters 6 to 8, and then exploring the applied .NET programming material in Chapters 11 to 20, referring to earlier chapters as necessary. Haskell programmers also need to learn the F# approach to imperative programming, described in Chapter 4, because many .NET libraries require a degree of imperative coding to create, configure, connect, and dispose of objects.

We strongly encourage you to use this book in conjunction with a development environment that supports F# directly, such as Visual Studio 2012 or Mono Develop 3.0. In particular, the interactive type inference in these environments is exceptionally helpful for understanding F# code; with a simple mouse movement, you can examine the inferred types of the sample programs. These types play a key role in understanding the behavior of the code.

---

■ **Note** You can download and install F# from [www.fsharp.net](http://www.fsharp.net). You can download all the code samples used in this book from [www.expert-fsharp.com](http://www.expert-fsharp.com); they were prepared and checked with F# 3.0. As with all books, it's inevitable that minor errors may exist in the text. An active errata and list of updates will be published at [www.expert-fsharp.com](http://www.expert-fsharp.com).

---

## CHAPTER 2



# Your First F# Program – Getting Started With F#

This chapter covers simple interactive programming with F# and .NET. To begin, download and install a version of the F# distribution from [www.fsharp.net](http://www.fsharp.net). (You may have a version on your machine already—for instance, if you have installed Visual Studio.) The sections that follow use F# Interactive, a tool you can use to execute fragments of F# code interactively, and one that is convenient for exploring the language. Along the way, you will see examples of the most important F# language constructs and many important libraries.

## Creating Your First F# Program

Listing 2-1 shows your first complete F# program. You may not follow it all at first glance, but we explain it piece by piece after the listing.

*Listing 2-1. Analyzing a String for Duplicate Words*

```
/// Split a string into words at spaces
let splitAtSpaces (text: string) =
    text.Split ' '
    |> Array.toList

/// Analyze a string for duplicate words
let wordCount text =
    let words = splitAtSpaces text
    let wordSet = Set.ofList words
    let numWords = words.Length
    let numDups = words.Length - wordSet.Count
    (numWords, numDups)

/// Analyze a string for duplicate words and display the results.
let showWordCount text =
    let numWords, numDups = wordCount text
    printfn "--> %d words in the text" numWords
    printfn "--> %d duplicate words" numDups
```

Paste this program into F# Interactive, which you can start by using the command line, by running `fsi.exe` from the F# distribution or by using an interactive environment, such as Visual Studio. If you're running from the command line, remember to enter `;;` to terminate the interactive entry—you don't need to do this in Visual Studio or other interactive environments.

---

■ **Tip** You can start F# Interactive in Visual Studio by selecting F# Interactive in the View menu or by pressing `Ctrl+Alt+F` in an F# file or script. A tool window appears, and you can send text to F# Interactive by selecting the text and pressing `Alt+Enter`.

---

```
C:\Users\dsyme\Desktop> fsi.exe

Microsoft (R) F# 3.0 Interactive build 11.0.50522.1
Copyright (c) Microsoft Corporation. All Rights Reserved.

For help type #help;;

> <paste in the earlier program here> ;;

val splitAtSpaces : text:string -> string list
val wordCount : text:string -> int * int
val showWordCount : text:string -> unit
```

---

Here, F# Interactive reports the type of the functions `splitAtSpaces`, `wordCount`, and `showWordCount` (you will learn more about types in a moment). The keyword `val` stands for *value*; in F# programming, functions are just values, a topic we return to in Chapter 3. Also, sometimes F# Interactive shows a little more information than we show in this book (such as some internal details of the generated values); if you're trying out these code snippets, you can ignore that additional information. For now, let's use the `wordCount` function interactively:

---

```
> let (numWords,numDups) = wordCount "All the king's horses and all the king's men";;

val numWords : int = 9
val numDups : int = 2
```

---

This code shows the results of executing the function `wordCount` and binding its two results to the names `numWords` and `numDups`, respectively. Examining the values shows that the given text contains nine words: two duplicates and seven words that occur only once. `showWordCount` prints the results instead of returning them as a value:

---

```
> showWordCount "Couldn't put Humpty together again";;

--> 5 words in the text
--> 0 duplicate words
```

---

From the output, you can more or less see what the code does. Now that you've done that, let's go through the program in detail.

## Documenting Code

Let's start with the definition of the `wordCount` function in Listing 2-1. The first line of the definition isn't code; rather, it's a comment:

```
/// Analyze a string for duplicate words
```

Comments are either lines starting with `//` or blocks enclosed by `(*` and `*)`. Comment lines beginning with three slashes (`///`) are XMLDoc comments and can, if necessary, include extra XML tags and markup. The comments from a program can be collected into a single `.xml` file and processed with additional tools.

## Using `let`

Now, look at the first two lines of the function `wordCount` in Listing 2-1. These lines define the function `wordCount` and the local value `words`, both using the keyword `let`:

```
let wordCount (text:string) =
    let words = ...
```

`let` is the single most important keyword you use in F# programming: it's used to define data, computed values, and functions. The left of a `let` binding is often a simple identifier, but it can also be a pattern. (See "Using Tuples" for examples.) It can also be a function name followed by a list of argument names, as in the case of `wordCount`, which takes one argument: `text`. The right of a `let` binding (after the `=`) is an expression.

---

## VALUES AND IMMUTABILITY

---

In other languages, a local *value* is called a local *variable*. In F#, however, you can't change the immediate value of locals after they've been initialized unless the local is explicitly marked as `mutable`, a topic we return to in Chapter 4. For this reason, F# programmers and the language specification tend to prefer the term *value* to *variable*.

As you'll see in Chapter 4, data indirectly referenced by a local value can still be mutable even if the local value isn't. For example, a local value that is a handle to a hash table can't be changed to refer to a different table, but the contents of the table itself can be changed by invoking operations that add and remove elements from the table. Many values and data structures in F# programming are completely *immutable*, *however*, in other words, neither the local value nor its contents can be changed through external mutation. These are usually just called *immutable values*. For example, all basic .NET types—such as integers, strings, and `System.DateTime` values—are immutable, and the F# library defines a range of immutable data structures, such as `Set` and `Map`, based on binary trees.

Immutable values offer many advantages. At first it may seem strange to define values you can't change. Knowing a value is immutable, however, means you rarely need to think about the value's *object identity*—you can pass such values to routines and know that they won't be mutated. You can also pass them among multiple threads without worrying about unsafe concurrent access to the values, which is discussed in Chapter 11.

---



## Understanding Types

F# is a typed language, so it's reasonable to ask what the *type* of `wordCount` is. F# Interactive has shown it already, but we can see it again:

```
wordCount;;

val it : (string -> int * int) = <fun:it@36>
```

This indicates that `wordCount` takes one argument of type `string` and returns `int * int`, which is F#'s way of saying “a pair of integers.” The keyword `val` stands for *value*, and the symbol `->` indicates that `wordCount` is a *function*. No explicit type is given in the program for the type of the argument `text`, because the full type for `wordCount` is *inferred* from its definition. We discuss type inference further in “What Is Type Inference?” and in more detail in later chapters.

Types are significant in both F# and .NET programming more generally for reasons that range from performance to coding productivity and interoperability. Types are used to help structure libraries, to guide you through the complexity of an API, and to place constraints on code to ensure that it can be implemented efficiently. Unlike in many other typed languages, F#'s type system is both simple and powerful, because it uses orthogonal, composable constructs, such as tuples and functions, to form succinct and descriptive types. Furthermore, type inference means you almost never have to write types in your program, although doing so can be useful.

Table 2-1 shows some of the most important Type constructors, which are the operators F# offers for defining new types (classes and delegates are well-known examples from other programming languages). Chapters 3 and 4 discuss all these types in more detail.

**Table 2-1.** Some important types and type constructors and their corresponding values—*int* is the type representing integer numbers.

Family of Types	Examples	Description
<i>type</i> option	<code>int option</code> , <code>option&lt;int&gt;</code>	A value of the given type or the special value <code>None</code> . For example: <code>Some 3</code> , <code>Some "3"</code> , <code>None</code> .
<i>type</i> list	<code>int list</code> , <code>list&lt;int&gt;</code>	An immutable linked list of values of the given type. All elements of the list must have the same type. For example: <code>[]</code> , <code>[3;2;1]</code> .
<i>type</i> 1 -> <i>type</i> 2	<code>int -&gt; string</code>	A function type, representing a value that accepts values of the first type and computes results of the second type. For example: <code>(fun x -&gt; x+1)</code> .
Family of Types	Examples	Description
<i>type</i> 1 * ... * <i>type</i> N	<code>int * string</code>	A tuple type, such as a pair, triple, or larger combination of types. For example: <code>(1, "3")</code> , <code>(3,2,1)</code> .
<i>type</i> []	<code>int []</code>	An array type for a flat, fixed-size, mutable collection.
unit	<code>unit</code>	A type containing a single value <code>()</code> , akin to <code>void</code> in many imperative languages.
'T	<code>'T</code> , <code>'a</code> , <code>'Key</code> , <code>'Value</code>	A variable type, used in generic code.

Some type constructors, such as `list` and `option`, are *generic*, which means they can be used to form a range of types by instantiating the generic variables, such as `int list`, `string list`, `int list list`, and so on. You can write instantiations of generic types using either prefix notation (such as `int list`) or postfix

notation (such as `list<int>`). Variable types such as `'a` and `'T` are placeholders for any type. Chapters 3 and 5 discuss generics and variable types in more detail.

---

## WHAT IS TYPE INFERENCE?

---

*Type inference* works by analyzing your code to collect constraints from the way you use let-introduced names without explicit type annotations. These are collected over the scope of particular parts of your program, such as each file for the F# command-line compiler and each chunk entered in F# Interactive. These constraints must be consistent, thus ensuring that your program is well typed; you get a type error if they are not. Constraints are collected from top to bottom, left to right, and outside in. This is important, because in some situations it may affect the inference process.

Type inference also *automatically generalizes* your code, which means that when your code is reusable and generic in certain obvious ways, it's given a suitable generic type without your needing to write down the generic type. Automatic generalization is the key to succinct but reusable typed programming. Chapter 5 discusses automatic generalization.

---

## Calling Functions

Functions are at the heart of most F# programming. It's not surprising that the first thing the `wordCount` function does is call a function—in this case, the `splitAtSpaces` function, which is the first function defined in the program:

```
let wordCount (text: string) =
    let words = splitAtSpaces text
```

Let's first investigate the `splitAtSpaces` function by running F# Interactive:

---

```
> splitAtSpaces "hello world";;

val it : string list = ["hello"; "world"]
```

---

You can see that `splitAtSpaces` breaks the given text into words, splitting at spaces. In the sample code, you can also see examples of:

- Literal characters, such as `' '` and `'a'`
- Literal strings, such as `"hello world"`
- Literal lists of strings, such as the returned value `[ "hello"; "world" ]`

Chapter 3 covers literals and lists in detail. Lists are an important data structure in F#, and you see many examples of their use in this book.

## Lightweight Syntax

The F# compiler and F# Interactive use the indentation of F# code to determine where constructs start and finish. The indentation rules are very intuitive; we discuss them in the appendix, which is a guide to the F# syntax. Listing 2-2 shows a version of the `wordCount` function that explicits all the scopes of names using the `in` keyword.

*Listing 2-2. A version of the wordCount function using explicit “in” tokens*

```
/// Analyze a string for duplicate words
let wordCount text =
    let words = splitAtSpaces text in
    let wordSet = Set.ofList words in
    let numWords = words.Length in
    let numDups = numWords - wordSet.Count in
    (numWords, numDups)
```

Double semicolons (;;) are still required to terminate entries to F# Interactive. If you’re using an interactive development environment such as Visual Studio, however, the environment typically adds them automatically when code is selected and executed. We show the double semicolons in the interactive code snippets used in this book, although not in the larger samples.

Sometimes it’s convenient to write let definitions on a single line. Do this by separating the expression that follows a definition from the definition itself, using in. For example:

```
let powerOfFour n =
    let nSquared = n * n in nSquared * nSquared
```

Here’s an example use of the function:

---

```
> powerOfFour 3;;
val it : int = 81
```

---

Indeed, let pat = expr1 in expr2 is the true primitive construct in the language, with pat standing for *pattern*, and expr1 and expr2 standing for *expressions*. The F# compiler inserts the in if expr2 is column-aligned with the let keyword on a subsequent line.

---

■ **Tip** We recommend that you use four-space indentation for F# code. Tab characters can’t be used, and the F# tools give an error if they’re encountered. Most F# editors convert uses of the Tab key to spaces automatically.

---

## Understanding Scope

Local values, such as words and wordCount, can’t be accessed outside their *scope*. In the case of variables defined using let, the scope of the value is the entire expression that follows the definition, although not the definition itself. Here are two examples of invalid definitions that try to access variables outside their scope. As you see, let definitions follow a sequential, top-down order, which helps ensure that programs are well-formed and free from many bugs related to uninitialized values:

```
let badDefinition1 =
    let words = splitAtSpaces text
    let text = "We three kings"
    words.Length

    gives
```

---

```
error FS0039: The value or constructor 'text' is not defined
```

---

and

```
let badDefinition2 = badDefinition2 + 1
```

gives

---

```
let badDefinition2 = badDefinition2 + 1
error FS0039: The value or constructor 'badDefinition2' is not defined
```

---

Within function definitions, you can *outscope* values by declaring another value of the same name. For example, the following function computes  $(n*n*n*n)+2$ :

```
let powerOfFourPlusTwo n =
    let n = n * n
    let n = n * n
    let n = n + 2
    n
```

This code is equivalent to:

```
let powerOfFourPlusTwo n =
    let n1 = n * n
    let n2 = n1 * n1
    let n3 = n2 + 2
    n3
```

Outscoping a value doesn't change the original value; it just means that the name of the value is no longer accessible from the current scope.

Because let bindings are simply a kind of expression, you can use them in a nested fashion. For example:

```
let powerOfFourPlusTwoTimesSix n =
    let n3 =
        let n1 = n * n
        let n2 = n1 * n1
        n2 + 2
    let n4 = n3 * 6
    n4
```

Here,  $n1$  and  $n2$  are values defined locally by let bindings within the expression that defines  $n3$ . These local values aren't available for use outside their scope. For example, this code gives an error:

```
let invalidFunction n =
    let n3 =
        let n1 = n + n
        let n2 = n1 * n1
        n1 * n2
    let n4 = n1 + n2 + n3    // Error! n3 is in scope, but n1 and n2 are not!
    n4
```

Local scoping is used for many purposes in F# programming, especially to hide implementation details that you don't want revealed outside your functions or other objects. Chapter 7 covers this topic in more detail.

## Using Data Structures

The next portion of the code is:

```
let wordCount (text:string) =
    let words = splitAtSpaces text
    let wordSet = Set.ofList words
    ...
```

This gives you your first taste of using data structures from F# code. The last of these lines lies at the heart of the computation performed by `wordCount`. It uses the function `Set.ofList` from the F# library to convert the given words to a concrete data structure that is, in effect, much like the mathematical notion of a set, although internally, it's implemented using a data structure based on trees. You can see the results of converting data to a set by using F# Interactive:

---

```
> Set.ofList ["b"; "a"; "b"; "b"; "c" ];;

val it : Set<string> = set [ "a"; "b"; "c" ]

> Set.toList (Set.ofList ["abc"; "ABC"]);;

val it : string list = ["ABC"; "abc"]
```

---

Here you can see several things:

- F# Interactive prints the contents of structured values, such as lists and sets.
- Duplicate elements are removed by the conversion.
- The elements in the set are ordered.
- The default ordering on strings used by sets is case sensitive.

The name `Set` references the F# module `Microsoft.FSharp.Collections.Set` in the F# library. This contains operations associated with values of the `Set<_>` type. It's common for types to have a separate module that contains associated operations. All modules under the `Microsoft.FSharp.Namespaces.Core.Collections`, `Text`, and `Control` can be referenced by simple one-word prefixes, such as `Set.ofList`. Other modules under these namespaces include `List`, `Option`, and `Array`.

## Using Properties and the Dot-Notation

The next two lines of the `wordCount` function compute the result you're after—the number of duplicate words. This is done by using two properties, `Length` and `Count`, of the values you've computed:

```
let numWords = words.Length
let numDups = numWords - wordSet.Count
```

F# performs resolution on property names at compile time (or interactively when you're using F# Interactive, in which there is no distinction between compile time and runtime). This is done using compile-time knowledge of the type of the expression on the left of the dot—in this case, `words` and `wordSet`. Sometimes, a type annotation is required in your code in order to resolve the potential ambiguity among possible property names. For example, the following code uses a type annotation to note that `inp` refers to a list. This allows the F# type system to infer that `Length` refers to a property associated with values of the `list` type:

```
let length (inp:'T list) = inp.Length
```

Here, the `'T` indicates that the `length` function is generic; that is, it can be used with any type of list. Chapters 3 and 5 cover generic code in more detail.

As you can see from the use of the dot-notation, F# is both a functional language and an object-oriented language. In particular, properties are a kind of *member*, a general term used for any functionality associated with a type or value. Members referenced by prefixing a type name are called *static members*, and members associated with a particular value of a type are called *instance members*; in other words, instance members are accessed through an object on the left of the dot. We discuss the distinction between values, properties, and methods later in this chapter, and Chapter 6 discusses members in full.

---

■ **Note** Type annotations can be useful documentation; when you use them, they should generally be added at the point where a variable is declared.

---

Sometimes, explicitly named functions play the role of members. For example, you could write the earlier code as:

```
let numWords = List.length words
let numDups = numWords - Set.count wordSet
```

You see both styles in F# code. Some F# libraries don't use members at all or use them only sparingly. Judiciously using members and properties, however, can greatly reduce the need for trivial `get/set` functions in libraries, can make client code much more readable, and can allow programmers who use environments such as Visual Studio to easily and intuitively explore the primary features of libraries they write.

If your code doesn't contain enough type annotations to resolve the dot-notation, you see an error such as:

---

```
> let length inp = inp.Length;;
```

```
error FS0072: Lookup on object of indeterminate type based on information prior to this
program point. A type annotation may be needed prior to this program point to constrain the
type of the object. This may allow the lookup to be resolved. You can resolve this by adding a
type annotation as shown earlier.
```

---

## Using Tuples

The final part of the `wordCount` function returns the results `numWords` and `numDups` as a *tuple*:

```

...
let numWords = words.Length
let numDups = numWords - wordSet.Count
(numWords, numDups)

```

Tuples are the simplest, but perhaps the most useful, of all F# data structures. A tuple expression is a number of expressions grouped together to form a new expression:

```

let site1 = ("www.cnn.com", 10)
let site2 = ("news.bbc.com", 5)
let site3 = ("www.msnbc.com", 4)
let sites = (site1, site2, site3)

```

Here, the inferred types and computed values are:

---

```

val site1 : string * int = ("www.cnn.com", 10)
val site2 : string * int = ("news.bbc.com", 5)
val site3 : string * int = ("www.msnbc.com", 4)
val sites : (string * int) * (string * int) * (string * int) =
  (("www.cnn.com", 10), ("news.bbc.com", 5), ("www.msnbc.com", 4))

```

---

Tuples can be decomposed into their constituent components in two ways. For pairs—that is, tuples with two elements—you can explicitly call the functions `fst` and `snd`, which, as their abbreviated names imply, extract the first and second parts of the pair:

---

```

> fst site1;;

val it : string = "www.cnn.com"

> let relevance = snd site1;;

val relevance : int = 10

```

---

The functions `fst` and `snd` are defined in the F# library and are always available for use by F# programs. Here are their simple definitions:

```

let fst (a, b) = a
let snd (a, b) = b

```

More commonly, tuples are decomposed using *patterns*, as in the code:

```

let url, relevance = site1
let siteA, siteB, siteC = sites

```

In this case, the names in the tuples on the left of the definitions are bound to the respective elements of the tuple value on the right; so again, `url` gets the value `"www.cnn.com"` and `relevance` gets the value `10`.

Tuple values are typed, and strictly speaking, there are an arbitrary number of families of tuple types: one for pairs holding two values, one for triples holding three values, and so on. This means that if you try to use a triple where a pair is expected, you get a type-checking error before your code is run:

---

```
> let a, b = (1, 2, 3);;

error FS0001: Type mismatch. Expecting a
    'a * 'b
but given a
    'a * 'b * 'c
The tuples have differing lengths of 2 and 3
```

---

Tuples are often used to return multiple values from functions, as in the `wordCount` example earlier. They're also often used for multiple arguments to functions, and frequently the tupled output of one function becomes the tupled input of another function. This example shows a different way of writing the `showWordCount` function defined and used earlier:

```
let showResults (numWords, numDups) =
    printfn "--> %d words in the text" numWords
    printfn "--> %d duplicate words" numDups

let showWordCount text = showResults (wordCount text)
```

The function `showResults` accepts a pair as input, decomposed into `numWords` and `numDups`. The two outputs of `wordCount` become the two inputs of `showResults`.

---

## VALUES AND OBJECTS

---

In F#, everything is a *value*. In some other languages, everything is an *object*. In practice, you can use the words largely interchangeably, although F# programmers tend to reserve *object* for special kinds of values:

- Values whose observable properties change as the program executes, usually through the explicit mutation of underlying in-memory data or through external state changes
- Values that refer to data or to a state that reveals an identity, such as a unique integer stamp or the overall object identity, where that identity is used to distinguish the object from otherwise identical values
- Values that can be queried to reveal additional functionality, through the use of casts, conversions, and interfaces

F# thus supports objects, but not all values are referred to as objects. F# programming is not “object-oriented”; rather, it uses objects where they are most useful. Chapter 4 discusses identity and mutation in more detail.

---

## Using Imperative Code

The `showWordCount` and `showResults` functions defined in the previous section output results using a library function called `printfn`:

```
printfn "--> %d words in the text" numWords
printfn "--> %d duplicate words" numDups
```



If you're familiar with OCaml, C, or C++, `printfn` will look familiar as a variant of `printf`—`printfn` also adds a newline character at the end of printing. Here, the pattern `%d` is a placeholder for an integer, and the rest of the text is output verbatim to the console.

F# also supports related functions, such as `printf`, `sprintf`, and `fprintf`, which are discussed further in Chapter 4. Unlike C/C++, `printf` is a type-safe text formatter in which the F# compiler checks that the subsequent arguments match the requirements of the placeholders. There are also other ways to format text with F#. For example, you can use the .NET libraries directly:

```
System.Console.WriteLine("--> {0} words in the text", box numWords)
System.Console.WriteLine("--> {0} duplicate words", box numDups)
```

Here, `{0}` acts as the placeholder, although no checks are made that the arguments match the placeholder before the code is run. The use of `printfn` also shows how you can use sequential expressions to cause effects in the outside world.

As with `let ... in ...` expressions, it's sometimes convenient to write sequential code on a single line. Do this by separating two expressions with a semicolon (`;`). The first expression is evaluated (usually for its side effects), its result is discarded, and the overall expression evaluates to the result of the second. Here is a simpler example of this construct:

```
let two = (printfn "Hello World"; 1 + 1)
let four = two + two
```

When executed, this code prints `Hello World` precisely once, when the right side of the definition of `two` is executed. F# doesn't have statements as such—the fragment `(printfn "Hello World"; 1 + 1)` is an expression, but when evaluated, the first part of the expression causes a side effect, and its result is discarded. It's also often convenient to use parentheses to delimit sequential code. The code from the script could, in theory, be parenthesized, with a semicolon added to make the primitive constructs involved more apparent:

```
(printfn "--> %d words in the text" numWords;
 printfn "--> %d duplicate words" numDups)
```

---

■ **Note** The token `;` is used to write sequential code within expressions, and `;` is used to terminate interactions with the F# Interactive session. Semicolons are optional when the individual fragments of your sequential code are placed on separate lines beginning at the same column position.

---

## Using Object-Oriented Libraries from F#

The value of F# lies not just in what you can do inside the language but also in what you can connect to outside the language. For example, F# doesn't come with a GUI library. Instead, F# is connected to .NET and via .NET to most of the significant programming technologies available on major computing platforms. You've already seen one use of the .NET libraries, in the first function defined earlier:

```
/// Split a string into words at spaces
let splitAtSpaces (text:string) =
    text.Split ' '
    |> Array.toList
```

Here, `text.Split` is a call to a .NET library instance method called `Split` defined on all string objects.

To emphasize this, the second sample uses two of the powerful libraries that come with the .NET Framework: `System.Net` and `System.Windows.Forms`. The full sample, in Listing 2-3, is a script for use with F# Interactive.

**Listing 2-3.** Using the .NET Framework Windows Forms and networking libraries from F# Interactive

```
open System.Windows.Forms

let form = new Form(Visible = true, TopMost = true, Text = "Welcome to F#")

let textB = new RichTextBox(Dock = DockStyle.Fill, Text = "Here is some initial text")
form.Controls.Add textB

open System.IO
open System.Net

/// Get the contents of the URL via a web request
let http (url: string) =
    let req = System.Net.WebRequest.Create(url)
    let resp = req.GetResponse()
    let stream = resp.GetResponseStream()
    let reader = new StreamReader(stream)
    let html = reader.ReadToEnd()
    resp.Close()
    html

textB.Text <- http "http://news.bbc.co.uk"
```

The above example uses several important .NET libraries and helps you explore some interesting F# language constructs. The following sections walk you through this listing.

## Using open to Access Namespaces and Modules

The first thing you see in the sample is the use of `open` to access functionality from the namespace `System.Windows.Forms`:

```
open System.Windows.Forms
```

Chapter 7 discusses namespaces in more detail. The earlier declaration means you can access any content under this path without quoting the long path. If it didn't use `open`, you'd have to write the following, which is obviously a little verbose:

```
let form = new System.Windows.Forms.Form(Visible = true, TopMost = true, Text = "Welcome to F#")
```

You can also use `open` to access the contents of an F# module without using long paths. Chapter 7 discusses modules in more detail.

---

## MORE ABOUT OPEN

---

Using `open` is an easy way to access the contents of namespaces and modules. There are some subtleties, however. For example, `open` doesn't actually load or reference a library—instead, it reveals functionality from already-loaded libraries. You load libraries by referring to a particular DLL, using `#r` in a script or `-r` as a command-line option.

Libraries and namespaces are orthogonal concepts: multiple libraries can contribute functionality to the same namespace, and each library can contribute functionality to multiple namespaces. Often, one particular library contributes most of the functionality in a particular namespace. For example, most of the functionality in the `System.Windows.Forms` namespace comes from a library called `System.Windows.Forms.dll`. As it happens, this library is automatically referenced by F# Interactive at startup, which is why you haven't needed an explicit reference to the library so far. You can place your code in a namespace by using a namespace declaration at the top of your file, as discussed in Chapter 7.

If two namespaces have types, subnamespaces, and/or modules with identical names, when you open these, you can access the contents of both using the same shortened paths. For example, the namespace `System` contains a type `String`, and the namespace `Microsoft.FSharp.Core` contains a module `String`. In this case, long identifier lookups such as `String.map` search the values and members under both of these, preferring the most recently opened if there is an ambiguity.

Finally, if you ever have name collisions, you can define your own short aliases for modules and types, such as by using `module MyString = My.Modules.String` and type `SysString = System.String`. You cannot alias namespaces.

---

## Using `new` and Setting Properties

The next lines of the sample script use the keyword `new` to create a top-level window (called a *form*) and set it to be visible. If you run this code in F# Interactive, you see a top-level window appear with the title text *Welcome to F#*:

```
let form = new Form(Visible = true, TopMost = true, Text = "Welcome to F#")
```

Here, `new` is shorthand for calling a function associated with the type `System.Windows.Forms.Form` that constructs a value of the given type—these functions are called *constructors*. Not all F# and .NET types have constructors; you also see values being constructed using names such as `System.Net.WebRequest.Create`, `String.init`, or `Array.init`. You see examples of each throughout this book.

A form is an *object*; that is, its properties change during the course of execution, and it's a handle that mediates access to external resources (the display device, mouse, and so on). Sophisticated objects such as forms often need to be configured, either by passing in configuration parameters at construction or by adjusting properties from their default values after construction. The arguments `Visible=true`, `TopMost=true`, and `Text="Welcome to F#"` set the initial values for three properties of the form. The labels `Visible`, `TopMost`, and `Text` must correspond to either named arguments of the constructor being called or properties on the return result of the operation. In this case, all three are object properties, and the arguments indicate initial values for the object properties.

Most properties on graphical objects can be adjusted dynamically. You set the value of a property dynamically using the notation `obj.Property <- value`. For example, you could also construct the form object as:

```
open System.Windows.Forms
let form = new Form()
form.Visible <- true
form.TopMost <- true
form.Text <- "Welcome to F#"
```

Likewise, you can watch the title of the form change by running the following code in F# Interactive:

```
form.Text <- "Programming is Fun!"
```

Setting properties dynamically is frequently used to configure objects, such as forms, that support many potential configuration parameters that evolve over time.

The object created here is bound to the name `form`. Binding this value to a new name doesn't create a new form; rather, two different handles now refer to the same object (they're said to *alias* the same object). For example, the following code sets the title of the same form, despite its being accessed via a different name:

```
let form2 = form
form2.Text <- "F# Forms are Fun"
```

---

## VALUES, FUNCTIONS, METHODS, AND PROPERTIES

---

Here are the differences among values, methods, and properties:

- **Values:** Parameters and top-level items defined using `let` or Pattern matching. Examples: `form`, `text`, `wordCount`.
- **Methods:** Named operations associated with types or values. Both simple values and objects may have methods. Methods can be overloaded (see Chapter 6) and must be applied immediately to their arguments. Examples: `System.Net.WebRequest.Create(url)` and `resp.GetResponseStream()`.
- **Properties:** Named "get" or "set" operations associated with types or values. A property is just shorthand for invoking method members that get or set underlying data. Examples: `System.DateTime.Now` and `form.TopMost`.
- **Indexer properties:** A property that accepts index arguments. Indexer properties named `Item` can be accessed using the `.[_]` syntax (note that the dot is required). Examples: `vector.[3]` and `matrix.[3,4]`.

The next part of the sample creates a new `RichTextBox` control and stores it in a variable called `textB`:

```
let textB = new RichTextBox(Dock = DockStyle.Fill)
form.Controls.Add(textB)
```

A control is typically an object with a visible representation—or, more generally, an object that reacts to operating-system events related to the windowing system. A form is one such control, but there are many others. A `RichTextBox` control is one that can contain formatted text, much like a word processor.

## Fetching a Web Page

The second half of Listing 2-3 uses the `System.Net` library to define a function `http` to read HTML Web pages. You can investigate the operation of the implementation of the function by entering the following lines into F# Interactive:

---

```
> open System;;
> open System.IO;;
> open System.Net;;

> let req = WebRequest.Create("http://www.microsoft.com");;

val req : WebRequest

> let resp = req.GetResponse();;

val resp : WebResponse

> let stream = resp.GetResponseStream();;

val stream : Stream

> let reader = new StreamReader(stream);;

val reader : StreamReader

> let html = reader.ReadToEnd();;

val html : string =
  "<html><head><title>Microsoft Corporation</title><meta http-equiv=[959 chars]

> textB.Text <- html;;
```

---

The final line sets the contents of the text-box form to the HTML contents of the Microsoft home page. Let's look at this code line by line.

The first line of the code creates a `WebRequest` object using the static method `Create`, a member of the type `System.Net.WebRequest`. The result of this operation is an object that acts as a handle to a running request to fetch a Web page—you could, for example, abandon the request or check to see whether the request has completed. The second line calls the instance method `GetResponse`. The remaining lines of the sample get a stream of data from the response to the request using `resp.GetResponseStream()`, make an object to read this stream using `new StreamReader(stream)`, and read the full text from this stream. Chapter 4 covers `.NET` I/O in more detail; for now, you can test by experimentation in F# Interactive that these actions do indeed fetch the HTML contents of a Web page. The inferred type for `http` that wraps up this sequence as a function is:

---

```
http;;

val it : (string -> string) = <fun:it@312-1>
```

---

■ **Note** *Static members* are items qualified by a concrete type or module. Examples include `System.String.Compare`, `System.DateTime.Now`, and `List.map`. *Instance members* are methods, properties, and values qualified by an expression. Examples include `form.Visible`, `resp.GetResponseStream()`, and `cell.contents`.

## XML HELP IN VISUAL STUDIO

In a rich editor such as Visual Studio, you can easily find out more about the functionality of .NET libraries by hovering your mouse over the identifiers in your source code. For example, if you hover over `Dock` in `textB.Dock`, you see the XML help shown here:

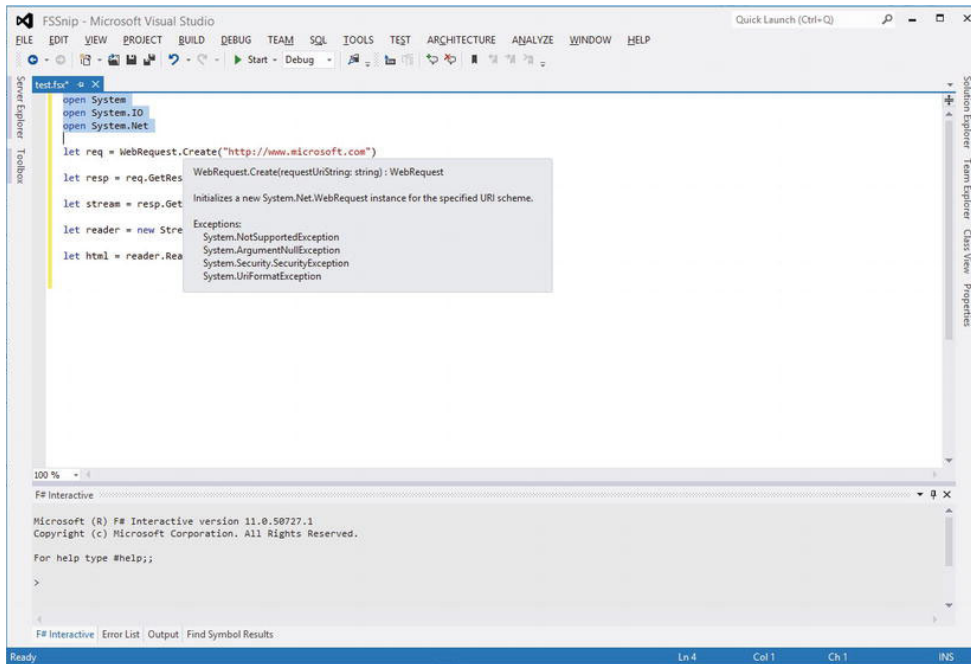

## Summary

This chapter looked at some simple interactive programming with F# and .NET. Along the way, you met many of the constructs you use in day-to-day F# programming. The next chapter takes a closer look at these and other constructs that are used to perform compositional and succinct functional programming in F#.

■ **Note** In Chapter 3, you will use some of the functions defined in this chapter. If you're using F# Interactive, you may want to leave your session open as you proceed.

## CHAPTER 3



# Introducing Functional Programming

F#'s effectiveness rests on the tried and tested foundation of functional programming. This chapter covers the core building blocks of functional programming with F#, including simple types and function values, pattern matching, lists and options. Chapters 4 through 6 cover imperative programming, generics, and object-oriented programming, and Chapters 9 and 10 cover many more advanced topics in functional programming with sequences, and structured and numeric data.

## Starting with Numbers and Strings

We first cover the most common base types of data manipulated in F# code, beginning with numbers and strings.

### Some Simple Types and Literals

Table 3-1 lists the basic numeric types used in F# code and their corresponding literal forms. The table also lists the nonnumeric types `bool` and `unit`.

*Table 3-1. Some Simple Types and Literals*

Type	Description	Sample Literals	Long Name
<code>bool</code>	True/false values	<code>true</code> , <code>false</code>	<code>System.Boolean</code>
<code>int</code>	32-bit signed integers	<code>0</code> , <code>19</code> , <code>0x0800</code> , <code>0b0001</code>	<code>System.Int32</code>
<code>float</code>	64-bit IEEE floating-point	<code>0.0</code> , <code>19.7</code> , <code>1.3e4</code>	<code>System.Double</code>
<code>string</code>	Unicode strings	<code>"abc"</code> , <code>@"\a\b"</code>	<code>System.String</code>
<code>unit</code>	The type with only one value	<code>()</code>	<code>Core.Unit</code>

Table 3-2 lists the most commonly used arithmetic operators. These are overloaded to work with all basic numeric types, including `int` and `float`.

*Table 3-2. Arithmetic Operators and Examples*

Operator	Description	Sample Use on <i>int</i>	Sample Use on <i>float</i>
+	Unchecked addition	1 + 2	1.0 + 2.0
-	Unchecked subtraction	12 - 5	12.3 - 5.4
*	Unchecked multiplication	2 * 3	2.4 * 3.9
/	Division	5 / 2	5.0 / 2.0
%	Modulus	5 % 2	5.4 % 2.0
-	Unary negation	-(5+2)	-(5.4+2.4)

The behavior of these and other operators can be extended for user-defined types, a topic covered in Chapter 6. In F#, addition, subtraction, and multiplication over integers are unchecked; that is, if overflow or underflow occurs beyond the representable range, then wraparound occurs. Checked arithmetic is discussed in Chapter 10.

Operator overloading interacts with type inference—if a use of an overloaded operator isn't otherwise constrained to work on a particular type, then F# assumes it works on 32-bit integers. To constrain a use of an operator to a particular type, you must give a type annotation that has the effect of telling the compiler the type on the left of the two arguments to the binary operator. For example, in the absence of additional type information, the following function is assumed to work with integers:

---

```
> let squareAndAdd a b = a * a + b;;
val squareAndAdd : a:int -> b:int -> int
```

---

A single type annotation on `a` is sufficient to indicate that `a * a` is an operation on float values and thus returns a float value, and that `a * a + b` is also an operation on float:

---

```
> let squareAndAdd (a:float) b = a * a + b;;
val squareAndAdd : a:float -> b:float -> float
```

---

In general, you can place such annotations on any of the function arguments or directly when you use them in the body of the function. If you want, you can also give full type annotations for the arguments and return type of a function:

---

```
> let squareAndAdd (a:float) (b:float) : float = a * a + b;;
val squareAndAdd : a:float -> b:float -> float
```

---

## Arithmetic Conversions

Numeric types aren't implicitly converted—conversions between different numeric types must be made explicitly. You do this by using overloaded conversion operators. These work the same way as overloaded infix operators, such as `+` and `*`. Table 3-3 shows the simplest and most common conversion operators. More conversion operators are described in Chapter 10.



**Table 3-3.** *The Simplest Overloaded Arithmetic Conversions and Examples*

Operator	Description	Sample Use	Result
int/int32	Convert/truncate to int32	int 17.8	17
		int -17.8	-17
string	Convert to string	string 65	"65"
float	Convert to float/double	float 65	65.0

## Arithmetic Comparisons

When used with numeric values, the binary comparison operators =, <>, <, <=, >, >=, min, and max perform comparisons according to the natural ordering for each particular numeric type. You can also use these operators on other data types, such as to compare lists of integers, and you can customize their behavior for new types that you define. Chapter 5 discusses generic comparison in detail, and Chapter 8 discusses customizing generic comparison.

## Simple Strings

The F# type `string` is an abbreviation for the type `System.String` and represents a sequence of Unicode UTF-16 characters. The operator `str.[index]` is used to access the elements of a string, the property `Length` retrieves its length, and the operator `str.[index..index]` can be used to take substrings:

---

```
> let s = "Couldn't put Humpty";;
val s : string = "Couldn't put Humpty"
> s.Length;;
val it : int = 19
> s.[13];;
val it : char = 'H'
> s.[13..16];;
val it : string = "Hump"
```

---

Strings are immutable; that is, a string value can't be modified after it's built. For example, the `Substring` method on the `string` type doesn't modify the original string but instead returns a new string representing the result. As mentioned in Chapter 2, immutability is a key concept for many F# values, and you encounter it many places in this book. If you attempt to mutate a string, you get an error like the one shown here:

---

```
> let s = "Couldn't put Humpty";;
val s : string = "Couldn't put Humpty"
> s.[13] <- 'h';;
error FS0751: Invalid indexer expression
```

---

The simplest way to build strings is via concatenation using the + operator:

---

```
> "Couldn't put Humpty" + " " + "together again";
val it : string = "Couldn't put Humpty together again"
```

---

Chapter 8 discusses other techniques for working with strings.

## Working with Conditionals: && and ||

A basic control construct in F# programming is if/then/elif/else. Here's an example:

```
let round x =
    if x >= 100 then 100
    elif x < 0 then 0
    else x
```

Conditionals are really shorthand for pattern matching; for example, the previous code could be written like this:

```
let round x =
    match x with
    | _ when x >= 100 -> 100
    | _ when x < 0 -> 0
    | _ -> x
```

Conditionals are always guarded by a Boolean-valued expression. You can build them using && and || (the “and” and “or” operators) as well as any library functions that return Boolean values:

```
let round2 (x, y) =
    if x >= 100 || y >= 100 then 100, 100
    elif x < 0 || y < 0 then 0, 0
    else x, y
```

The operators && and || have the usual short-circuit behavior in that the second argument of && is evaluated only if the first evaluates to true and, likewise, the second argument of || is evaluated only if the first evaluates to false.

## Defining Recursive Functions

A fundamental building block of computation in F# is recursion. The following code shows a simple, well-known recursive function:

---

```
> let rec factorial n = if n <= 1 then 1 else n * factorial (n - 1);;
val factorial : n:int -> int
> factorial 5;;
val it : int = 120
```

---

This example shows that a recursive function is simply one that can call itself as part of its own definition. Recursive functions are introduced by `let rec`. Functions aren't recursive by default, because it's wise to isolate recursive functions to help you control the complexity of your algorithms and keep your code maintainable. It may help to visualize the execution of `factorial 5` in the following way (note that, in reality, F# executes the function using efficient native code):

---

```
factorial 5
= 5 * factorial 4
= 5 * (4 * factorial 3)
= 5 * (4 * (3 * factorial 2))
= 5 * (4 * (3 * (2 * factorial 1 )))
= 5 * (4 * (3 * (2 * 1)))
= 5 * (4 * (3 * 2))
= 5 * (4 * 6)
= 5 * 24
= 120
```

---

As with all calls, the execution of the currently executing instance of the function is suspended while a recursive call is made.

Many of the operators you've encountered so far can be coded as recursive functions. For example, the following is one possible implementation of `List.length`:

```
let rec length l =
    match l with
    | [] -> 0
    | h :: t -> 1 + length t
```

Likewise, many other list processing functions, such as `List.iter`, are often implemented using recursive functions.

Recursion is sometimes used as a means of programming particular patterns of control. For example, the following code repeatedly fetches the HTML for a particular web page, printing each time it's fetched:

```
let rec repeatFetch url n =
    if n > 0 then
        let html = http url
        printfn "fetched <<< %s >>> on iteration %d" html n
        repeatFetch url (n - 1)
```

Recursion is powerful, but it is not always the ideal way to encode either data manipulations or control constructs, at least if other techniques are readily available. For example, the previous program could be implemented using a `for` loop (as explained in Chapter 4), which would be clearer. Likewise, you should typically avoid explicit recursion if an operator that captures the pattern of recursion being used is available. For example, many explicit loops and recursive functions can be replaced by uses of functions such as `List.map` and `Array.map`.

A typical error with recursion is to forget to decrement a variable at the recursive call. For example, we incorrectly entered the following nonterminating function when writing this chapter:

```
let rec badFactorial n = if n <= 1 then 1 else n * badFactorial n
```

You should always check your recursive calls to ensure that the function is tending toward termination—that is, that the arguments are approaching the base case. This is called *well-founded recursion*.

You can define multiple recursive functions simultaneously by separating the definitions with `and`. These are called *mutually recursive functions*. For example:

```
let rec even n = (n = 0u) || odd(n - 1u)
and odd n = (n <> 0u) && even(n - 1u)
```

This gives the following types:

---

```
val even : n:uint32 -> bool
val odd : n:uint32 -> bool
```

---

Of course, a more efficient, nonrecursive implementation of these is available:

```
let even n = (n % 2u) = 0u
let odd n = (n % 2u) = 1u
```

You must sometimes take care with recursive functions to ensure that they're *tail recursive*, or else the computation stack of your program may be exhausted by large inputs. This is particularly important for library functions or functions that operate over large data structures with very large numbers of recursive calls. Indeed, the implementation of `length` shown previously isn't tail recursive. Chapter 9 discusses tail recursion in depth.

## Lists

Some of the foundational data structures of F# coding are tuples, lists, and options. The following sections discuss these and some related topics by example.

F# lists are a common data structure used in functional programming. You saw some examples of concrete lists in Chapter 2. Table 3-4 shows the primitive constructs for building lists.

**Table 3-4.** Some List-Related Language Constructs and Operators

Operator/Expression	Description	Examples
<code>[]</code>	The empty list	<code>[]</code>
<code>expr :: expr</code>	“Cons” an element with a list	<code>1 :: [2; 3]</code>
<code>[expr; ...; expr]</code>	A list value	<code>[1; 2; 3]</code>
<code>[expr .. expr]</code>	A range	<code>[1 .. 99]</code> and <code>['A' .. 'Z'];;</code>
<code>[for x in list ...]</code>	A generated list (see end of chapter)	<code>[for x in 1..99 -&gt; x * x]</code>
<code>expr @ expr</code>	Concatenates two lists	<code>[1; 2] @ [3]</code>

Here are some basic list values:

```
let oddPrimes = [3; 5; 7; 11]
let morePrimes = [13; 17]
```

```
let primes = 2 :: (oddPrimes @ morePrimes)
```

The type and value of `primes` are as follows:

---

```
val primes : int list = [2; 3; 5; 7; 11; 13; 17]
```

---

Lists are immutable: the `cons ::` and `append @` operations don't modify the original lists; instead, they create new lists. You can see this in the following interactive session:

---

```
> let people = [ "Adam"; "Dominic"; "James" ];;
val people : string list = ["Adam"; "Dominic"; "James"]
> "Chris" :: people;;
val it : string list = ["Chris"; "Adam"; "Dominic"; "James"]
> people;;
val it : string list = ["Adam"; "Dominic"; "James"]
```

---

Note that `people` has not been changed by the construction of a new list using the `cons` operator. F# lists are immutable, and they are represented in memory as linked lists; each F# list value is a cons cell containing a value plus a pointer to the next chain in the list, or else it's a special `nil` object. When you create a new list using the `::` operator, then the tail of the new list points to the old list, which ensures that the inner memory associated with lists is often reused as part of multiple list values.

The F# library also includes a module `List` that contains some useful functions related to programming with lists. You see many of these functions in the next section and throughout this book. Table 3-5 shows some of them.

F# lists aren't appropriate for all circumstances. For example, very large data structures should probably be represented using arrays or other data structures, or even managed by an external tool, such as a relational database. We discuss a number of immutable data structures in “Some Common Immutable Data Structures” (see sidebar).

*Table 3-5. Some Sample Functions in the List Module*

Function	Type	Description
<code>List.length</code>	<code>'T list -&gt; int</code>	Returns the length of the list.
<code>List.head</code>	<code>'T list -&gt; 'T</code>	Returns the first element of a nonempty list.
<code>List.tail</code>	<code>'T list -&gt; 'T list</code>	Returns all the elements of a nonempty list except the first.
<code>List.init</code>	<code>int -&gt; (int -&gt; 'T) -&gt; 'T list</code>	Returns a new list. The length of the new list is specified by the first parameter. The second parameter must be a generating function that maps list indexes to values.
<code>List.append</code>	<code>'T list -&gt; 'T list -&gt; 'T list</code>	Returns a new list containing the elements of the first list followed by the elements of the second list.

<code>List.filter</code>	<code>('T -&gt; bool) -&gt; 'T list -&gt; 'T list</code>	Returns a new list containing only those elements of the original list where the function returns true.
<code>List.map</code>	<code>('T -&gt; 'U) -&gt; 'T list -&gt; 'U list</code>	Creates a new list by applying a function to each element of the original list.
<code>List.iter</code>	<code>('T -&gt; unit) -&gt; 'T list -&gt; unit</code>	Executes the given function for each element of the list.
<code>List.unzip</code>	<code>('T * 'U) list -&gt; 'T list * 'U list</code>	Returns two new lists containing the first and second elements of the pairs in the input list.
<code>List.zip</code>	<code>'T list -&gt; 'U list -&gt; ('T * 'U) list</code>	Returns a new list containing the elements of the two input lists combined pairwise. The input lists must be the same length; otherwise, an exception is raised.
<code>List.toArray</code>	<code>'T list -&gt; 'T []</code>	Creates an array from the given list.
<code>List.ofArray</code>	<code>'T [] -&gt; 'T list</code>	Creates a list from the given array.

---

Here are examples of how to use some of the functions from Table 3-5. The last two use *function values*, which we cover in more detail in “Introducing Function Values” later in this chapter.

---

```
> List.head [5; 4; 3];;
val it : int = 5
> List.tail [5; 4; 3];;
val it : int list = [4; 3]
> List.map (fun x -> x * x) [1; 2; 3];;
val it : int list = [1; 4; 9]
> List.filter (fun x -> x % 3 = 0) [2; 3; 5; 7; 9];;
val it : int list = [3; 9]
```

---

## SOME COMMON IMMUTABLE DATA STRUCTURES

---

Data structures are generally divided between *mutable* and *immutable*, a distinction touched on in Chapter 2 and covered in more detail in Chapter 4. Immutable data structures are sometimes called *persistent*, or simply *functional*. Here are some of the immutable data structures commonly used with F#:

- *Tuple values and option values*: These are immutable and are basic workhorses of F# programming.
- *Immutable linked lists of type 'T list*: These are cheap to access from the left end. They're inefficient for random-access lookup because the list must be traversed from the left for each lookup—that is, random-access lookup is  $O(n)$ , where  $n$  is the number of elements in the collection. The full name of this type is `Microsoft.FSharp.Collections.List<'T>`.

- *Immutable sets based on balanced trees:* Chapter 2 shows some examples of uses of immutable sets, and an implementation is provided via the type `Set<'T>` in the F# library namespace `Microsoft.FSharp.Collections`. These are cheap to add, access, and union, with  $O(\log(n))$  access times, where  $n$  is the number of elements in the collection. Because the type is immutable, internal nodes can be shared among different sets.
- *Immutable maps based on balanced trees:* These are similar to immutable sets but associate keys with values (that is, they're immutable dictionaries). One implementation of these is provided via the F# library type `Map<'Key, 'Value>` in `Microsoft.FSharp.Collections`. As with sets, these have  $O(\log(n))$  access times.

Chapter 4 covers imperative programming and mutable data structures.

---

## Options

Like lists and tuples, option values are simple constructs frequently used as workhorses in F# coding. An option is simply either a value “Some *v*” or the absence of a value “None”. For example, options are useful for returning the value of a search where you may or may not have a result. You see in the section “Defining Discriminated Unions” in Chapter 4 that the option type is defined in the F# library as follows:

```
type 'T option =
    | None
    | Some of 'T
```

The following is a data structure that uses options to represent the (optional) parents of some well-known characters:

---

```
> let people = [("Adam", None);
                ("Eve", None);
                ("Cain", Some("Adam", "Eve"));
                ("Abel", Some("Adam", "Eve"))];;

val people : (string * (string * string) option) list =
    [("Adam", None); ("Eve", None); ("Cain", Some ("Adam", "Eve"));
     ("Abel", Some ("Adam", "Eve"))]
```

---

One use of option values is to represent the success or failure of a computation. This can be useful when you're catching an exception, as shown in the following example (which uses the function `http` from Chapter 2):

```
let fetch url =
    try Some (http url)
    with :? System.Net.WebException -> None
```

Chapter 4 describes exceptions in more detail. What matters here is that if a network error occurs during the HTTP request, the exception is caught and the result of the `fetch` function is the value `None`. Successful web-page requests return a `Some` value. Option values can then be discriminated and decomposed using pattern matching, as shown here:

---

```
> match (fetch "http://www.nature.com") with
| Some text -> printfn "text = %s" text
| None -> printfn "**** no web page found";;
```

```
text = <!DOCTYPE html PUBLIC ... (note: the HTML is shown here if connected to the web)
```

---

## Getting Started with Pattern Matching

One important tool in F# programming is *pattern matching*, a general construct that combines decomposition and control. In the previous sections, you got a taste of how you can use pattern matching with some simple values, such as tuples and options. You can also use pattern matching in many other situations, however. You will see many other examples of pattern matching in this book, but let's start with some simple pattern matching over strings and integers. As you've already seen, pattern matches on explicit values are introduced using the `match ... with ...` construct:

```
let isLikelySecretAgent url agent =

    match (url, agent) with
    | "http://www.control.org", 99 -> true
    | "http://www.control.org", 86 -> true
    | "http://www.kaos.org", _ -> true    | _ -> false
```

The inferred type of the function is as follows:

---

```
val isLikelySecretAgent : url:string -> agent:int -> bool
```

---

The expression `(url, agent)` after the keyword `match` is a tuple of type `(string*int)`. You can omit the parentheses here (as in the subsequent `|` patterns) and use them only when you need to group inner tuples together, but it's a good practice to keep them around the values you are matching against. Each rule of the `match` is introduced with a `|` followed by a pattern, then `->`, and then a result expression. When executed, the patterns of the rules are used one by one, and the first successful pattern match determines which result expression is used. In the previous example, the first rule matches if `url` and `agent` are `"http://www.control.org"` and `99`, respectively. Likewise, the second rule matches `"http://www.control.org"` and `86`. The third rule matches if `url` is `"http://www.kaos.org"`, regardless of agent number. The last two rules all use "wildcard" patterns represented by the underscore character; these match all inputs.

The overall conditions under which `isLikelySecretAgent` returns `true` can be determined by reading through the pattern match: agents `86` and `99` are known agents of `"http://www.control.org"`, all agent numbers at `http://www.kaos.org` are assumed to be agents, and no other inputs are categorized as agents.

Patterns are a rich and powerful technique for simultaneous data analysis and decomposition. Patterns are also used in many workhorse situations. For example, pattern matching can be used to decompose list values from the head downward:

```
let printFirst primes =
    match primes with
    | h :: t -> printfn "The first prime in the list is %d" h
    | [] -> printfn "No primes found in the list"
```

---

```
> printFirst oddPrimes;;
```

```
The first prime in the list is 3
```

---



The first line after the match is a pattern-matching rule that matches the input `primes` against the pattern `h :: t`. If `primes` is a nonempty list, then the match is successful, and the first `printfn` is executed with `h` bound to the head of the list and `t` to its tail. The second line considers the case in which `primes` is an empty list. Note that the `::` and `[]` symbols can be used both to build up lists in expressions and to decompose them in pattern matching.

Likewise, pattern matching can be used to examine option values:

---

```
> let showParents (name, parents) =
    match parents with
    | Some (dad, mum) -> printfn "%s has father %s, mother %s" name dad mum
    | None -> printfn "%s has no parents!" name;;

val showParents : name:string * parents:(string * string) option -> unit

> showParents ("Adam", None);;

Adam has no parents!
```

---

## Matching on Structured Values

Pattern matching can be used to decompose structured values. Here is an example in which you match nested tuple values:

```
let highLow a b =
    match (a, b) with
    | ("lo", lo), ("hi", hi) -> (lo, hi)
    | ("hi", hi), ("lo", lo) -> (lo, hi)
    | _ -> failwith "expected a both a high and low value"
```

The match examines two pairs and looks at the strings in the first element of each, returning the associated values:

---

```
> highLow ("hi", 300) ("lo", 100);;

val it : int * int = (100, 300)
```

---

The first rule matches if the first parts of the input pairs are the strings "lo" and "hi", respectively. It then returns a pair made from the respective second parts of the tuples. The second rule is the mirror of this in case the values appeared in reverse order.

The final cases of both of the previous examples use wildcard patterns to cover remaining cases. This makes the patterns *exhaustive*. Frequently, no wildcard is needed to ensure this, because for many input types, F# is able to determine whether the given set of rules is sufficient to cover all possibilities for the given shape of data. If a match isn't exhaustive, however, a warning is given:

---

```
> let urlFilter3 url agent =
    match url,agent with
    | "http://www.control.org", 86 -> true
    | "http://www.kaos.org", _ -> false;;
```

---

*warning FS0025: Incomplete pattern matches on this expression. For example, the value '(\_,0)' may indicate a case not covered by the pattern(s).*  
`val urlFilter3 : url:string -> agent:int -> bool`

---

In these cases, it may be necessary to add an extra exception-throwing clause to indicate to the F# compiler that the given inputs aren't expected:

```
let urlFilter4 url agent =
    match url,agent with
    | "http://www.control.org", 86 -> true
    | "http://www.kaos.org", _ -> false
    | _ -> failwith "unexpected input"
```

Nonexhaustive matches are automatically augmented by a default case in which a `MatchFailureException` is thrown. Chapter 4 discusses exceptions.

F# is frequently able to determine whether pattern-matching rules are redundant, such as if a rule can never be selected because previous rules subsume all such cases. In this case, a warning is given. For example:

---

```
> let urlFilter2 url agent =
    match url,agent with
    | "http://www.control.org", _ -> true
    | "http://www.control.org", 86 -> true
    | _ -> false;;
```

*warning FS0026: This rule will never be matched*  
`val urlFilter2 : url:string -> agent:int -> bool`

---

■ **Tip** Use wildcard patterns with care. F# can often determine whether a match is exhaustive, and the use of wildcard patterns effectively disables this analysis for any particular pattern match. Sometimes it's better to write out the extra cases of a match as explicit patterns, because you can then adjust your code when new kinds of input data are introduced.

---

## Guarding Rules and Combining Patterns

Individual rules of a match can be guarded by a condition that is tested if the pattern itself succeeds. Here is a simple use of this mechanism to record the three clauses of computing the sign of an integer:

```
let sign x =
    match x with
    | _ when x < 0 -> -1
    | _ when x > 0 -> 1
    | _ -> 0
```

You can combine two patterns to represent two possible paths for matching:

```
let getValue a =
    match a with
    | (("lo" | "low"), v) -> v
    | ("hi", v) | ("high", v) -> v
    | _ -> failwith "expected a both a high and low value"
```

Here, the pattern `("lo" | "low")` matches either string. The pattern `("hi", v) | ("high", v)` plays essentially the same role by matching pairs values where the left of the pair is "hi" or "high" and by binding the value `v` on either side of the pattern.

## Further Ways of Forming Patterns

Table 3-6 summarizes all the ways to form patterns in F#; many of these involve building up patterns from other patterns. Chapter 8 covers active patterns and looks at further techniques for working with structured data.

*Table 3-6. Different Ways to Form Patterns*

General Form	Kind	Example
<code>(pat, ... , pat)</code>	Tuple pattern	<code>(1, 2, ("3", x))</code>
<code>[pat; ... ; pat]</code>	List pattern	<code>[x; y; z]</code>
<code>[  pat; ... ; pat  ]</code>	Array pattern	<code>[ "cmd"; arg1; arg2 ]</code>
<code>{id=pat; ... ; id=pat}</code>	Record pattern	<code>{ X = 1; Y = 2 }</code>
<code>Tag(pat, ... , pat)</code>	Tagged union or active pattern	<code>Point(x, y)</code>
<code>pat   pat</code>	“Or” pattern	<code>[x]   ["X"; x]</code>
<code>pat &amp; pat</code>	“And” pattern	<code>[p] &amp; [Point(x, y)]</code>
<code>pat as id</code>	Named pattern	<code>[x] as inp</code>
<code>id</code>	Variable pattern	<code>x</code>
<code>-</code>	Wildcard pattern	<code>-</code>
Any literal	Constant pattern	<code>36, "36", 27L, System.DayOfWeek. Monday</code>
<code>:? Type</code>	Type test pattern	<code>:? string</code>
<code>null</code>	Null test pattern	<code>null</code>

■ **Note** Individual patterns can’t bind the same variables twice. For example, a pattern `(x, x)` isn’t permitted, although `(x, y)` when `x = y` is permitted. Furthermore, each side of an “or” pattern must bind the same set of variables, and these variables must have the same types.

## Introducing Function Values

This section covers the foundational building block of F# functional programming: function values. We begin with a simple and well-known example: using function values to transform one list into another.

One of the primary uses of F# lists is as a general-purpose, concrete data structure for storing ordered input lists and ordered results. Input lists are often transformed to output lists using aggregate operations that transform, select, filter, and categorize elements of the list according to a range of criteria. These aggregate operations provide an excellent introduction to how to use function values. Let's take a closer look at this in the following code sample, which continues from the definition of `http` from Listing 2-2 in Chapter 2:

---

```
> let sites = ["http://www.live.com"; "http://www.google.com"];;
val sites : string list = ["http://www.live.com"; "http://www.google.com"];;
> let fetch url = (url, http url);;
val fetch : url:string -> string * string
> List.map fetch sites;
val it : (string * string) list =
    [("http://www.live.com",
     "<!-- ServerInfo:...
</body></html>");
     ("http://www.google.com",
     "<!doctype html>...
</script>")]
```

---

The first interaction defines `sites` as a literal list of URLs, and the second defines the function `fetch`. The third calls the aggregate operation `List.map`. This accepts the function value `fetch` as the first argument and the list `sites` as the second argument. The function applies `fetch` to each element of the list and collects the results in a new list.

Types are one useful way to help learn what a function does. Here's the type of `List.map`:

---

```
> List.map;;
val it : (('a -> 'b) -> 'a list -> 'b list)
```

---

This says `List.map` accepts a function value as the first argument and a list as the second argument, and it returns a list as the result. The function argument can have any type `'a -> 'b`, and the elements of the input list must have a corresponding type `'a`. The symbols `'a` and `'b` are called *type parameters*, and functions that accept type parameters are called *generic*. Chapter 5 discusses type parameters in detail.

---

**Tip** You can often deduce the behavior of a function from its type, especially if its type involves type parameters. For example, look at the type of `List.map`. Using type parameters, you can observe that the type `'T list` of the input list is related to the type `'T` accepted by the function passed as the first parameter. Similarly, the type `'U` returned by this function is related to the type `'U list` of the value returned by `List.map`. From this, it's reasonable to conclude that `List.map` calls the function parameter for items in the list and constructs its result using the values returned.

---

## Using Anonymous Function Values

Function values are so common in F# programming that it's convenient to define them without giving them names. Here is a simple example:

---

```
> let primes = [2; 3; 5; 7];;
val primes : int list = [2; 3; 5; 7]
> let primeCubes = List.map (fun n -> n * n * n) primes;;
val primeCubes: int list = [8; 27; 125; 343]
```

---

The definition of `primeCubes` uses the *anonymous function value* `(fun n -> n * n * n)`. Such values are similar to function definitions but are unnamed and appear as an expression rather than as a `let` declaration. `fun` is a keyword meaning function, `n` represents the argument to the function, and `n * n * n` is the result of the function. The overall type of the anonymous function expression is `int -> int`. You could use an anonymous function instead of the intermediary function `fetch` in the earlier sample:

```
let resultsOfFetch = List.map (fun url -> (url, http url)) sites
```

You will see anonymous functions throughout this book. Here is another example:

---

```
> List.map (fun (_,p) -> String.length p) resultsOfFetch;;
val it : int list = [12134; 45134]
```

---

Here you see two things:

- The argument of the anonymous function is a tuple pattern. Using a tuple pattern automatically extracts the second element from each tuple and gives it the name `p` within the body of the anonymous function.
- Part of the tuple pattern is a wildcard pattern, indicated by an underscore. This indicates that you don't care what the first part of the tuple is; you're interested only in extracting the length from the second part of the pair.

## Computing with Aggregate Operators

Functions such as `List.map` are called *aggregate operators*, and they're powerful constructs, especially when combined with the other features of F#. Here is a longer example that uses the aggregate operators `Array.filter` and `List.map` to count the number of URL links in an HTML page and then collects stats on a group of pages (this sample uses the function `http` defined in Chapter 2):

```
let delimiters = [| ' '; '\n'; '\t'; '<'; '>'; '=' |]

let getWords (s: string) = s.Split delimiters

let getStats site =
    let url = "http://" + site
    let html = http url
```

```
let hwords = html |> getWords
let hrefs = html |> getWords |> Array.filter (fun s -> s = "href")
(site, html.Length, hwords.Length, hrefs.Length)
```

Here, you use the function `getStats` with three web pages:

---

```
> let sites = ["www.live.com"; "www.google.com"; "search.yahoo.com"];;
val sites : string list
> sites |> List.map getStats;;
val it : (string * int * int * int) list =
  [("www.live.com", 12132, 892, 11); ("www.google.com", 44139, 2586, 33);
   ("search.yahoo.com", 12617, 846, 23)]
```

---

The function `getStats` computes the length of the HTML for the given web site, the number of words in the text of that HTML, and the approximate number of links on that page.

The previous code sample extensively uses the `|>` operator to *pipeline* operations, discussed in “Pipelining with `|>`” (see sidebar). The F# library design ensures that a common, consistent set of aggregate operations is defined for each structured type. Table 3-7 shows how the same convention is used for the `map` abstraction.

**Table 3-7.** A Recurring Aggregate Operator Design Pattern from the F# Library

Operator	Type
<code>List.map</code>	<code>('T -&gt; 'U) -&gt; 'T list -&gt; 'U list</code>
<code>Array.map</code>	<code>('T -&gt; 'U) -&gt; 'T [] -&gt; 'U []</code>
<code>Option.map</code>	<code>('T -&gt; 'U) -&gt; 'T option -&gt; 'U option</code>
<code>Seq.map</code>	<code>('T -&gt; 'U) -&gt; seq&lt;'T&gt; -&gt; seq&lt;'U&gt;</code>

You may see types that define methods that provide a slightly more succinct way of transforming data, such as `Map`. For example, you might represent sites by a new type with a `Map` instance member to compute site statistics, allowing you to write a transformation on a given site instance, like so:

```
site.Map getStats
```

This may require the use of a type annotation. Both styles are used in F# programming, depending on the methods and properties available for a particular data type.

---

## PIPELINING WITH `|>`

---

The `|>` forward pipe operator is perhaps the most important operator in F# programming. Its definition is deceptively simple:

```
let (|>) x f = f x
```

Here is how to use the operator to compute the cubes of three numbers:

```
[1;2;3] |> List.map (fun x -> x * x * x)
```

This produces [1; 8; 27], just as if you had written:

```
List.map (fun x -> x * x * x) [1; 2; 3]
```

In a sense, `|>` is function application in reverse. However, using `|>` has distinct advantages:

- *Clarity:* When used in conjunction with functions such as `List.map`, the `|>` operator allows you to perform the data transformations and iterations in a forward-chaining, pipelined style.
- *Type inference:* Using the `|>` operator lets type information flow from input objects to the functions manipulating those objects. F# uses information collected from type inference to resolve some language constructs, such as property accesses and method overloading. This relies on information being propagated left to right through the text of a program. In particular, typing information to the right of a position isn't taken into account when resolving property access and overloads.

For completeness, here is the type of the operator:

```
val (|>) : 'T -> ('T -> 'U) -> 'U
```

## Composing Functions with `>>`

You saw earlier how to use the `|>` forward pipe operator to pipe values through a number of functions. This was a small example of the process of *computing with functions*, an essential and powerful programming technique in F#. This section covers ways to compute new function values from existing ones using compositional techniques. First, let's look at function composition. For example, consider the following code:

```
let google = http "http://www.google.com"

google |> getWords |> Array.filter (fun s -> s = "href") |> Array.length
```

You can rewrite this code using function composition as follows:

```
let countLinks = getWords >> Array.filter (fun s -> s = "href") >> Array.length

google |> countLinks
```

You define `countLinks` as the composition of three function values using the `>>` forward composition operator. This operator is defined in the F# library as follows:

```
let (>>) f g x = g(f(x))
```

You can see from the definition that `f >> g` gives a function value that first applies `f` to the `x` and then applies `g`. Here is the type of `>>`:

```
val (>>) : ('T -> 'U) -> ('U -> 'V) -> ('T -> 'V)
```

Note that `>>` is typically applied to only two arguments: those on either side of the binary operator, here named `f` and `g`. The final argument `x` is typically supplied at a later point.

F# is good at optimizing basic constructions of pipelines and composition sequences from functions—for example, the function `countLinks` shown earlier becomes a single function calling the three functions in the pipeline in sequence. This means sequences of compositions can be used with relatively low overhead.

## Building Functions with Partial Application

Composing functions is just one way to compute interesting new functions. Another useful way is to use *partial application*. Here's an example:

```
let shift (dx, dy) (px, py) = (px + dx, py + dy)
let shiftRight = shift (1, 0)
let shiftUp = shift (0, 1)
let shiftLeft = shift (-1, 0)
let shiftDown = shift (0, -1)
```

The last four functions are defined by calling `shift` with only one argument, in each case leaving a residue function that expects an additional argument. F# Interactive reports the types as follows:

---

```
val shiftRight : (int * int -> int * int)
val shiftUp : (int * int -> int * int)
val shiftLeft : (int * int -> int * int)
val shiftDown : (int * int -> int * int)
```

---

Here is an example of how to use `shiftRight` and how to apply `shift` to new arguments `(2, 2)`:

---

```
> shiftRight (10, 10);;
val it : int * int = (11, 10)
> List.map (shift (2,2)) [(0,0); (1,0); (1,1); (0,1)];;
val it : (int * int) list = [(2, 2); (3, 2); (3, 3); (2, 3)]
```

---

In the second example, the function `shift` takes two pairs as arguments. You bind the first parameter to `(2, 2)`. The result of this partial application is a function that takes one remaining tuple parameter and returns the value shifted by two units in each direction. This resulting function can now be used in conjunction with `List.map`.

## Using Local Functions

Partial application is one way in which functions can be computed rather than simply defined. This technique becomes very powerful when combined with additional local definitions. Here's a simple and practical example, representing an idiom common in graphics programming:

```
open System.Drawing
```



```

let remap (r1:Rectangle) (r2:Rectangle) =
    let scalex = float r2.Width / float r1.Width
    let scaley = float r2.Height / float r1.Height
    let mapx x = int (float r2.Left + truncate (float (x - r1.Left) * scalex))
    let mapy y = int (float r2.Top + truncate (float (y - r1.Top) * scaley))
    let mapp (p:Point) = Point(mapx p.X, mapy p.Y)
    mapp

```

The function `remap` computes a new function value `mapp` that maps points in one rectangle to points in another. F# Interactive reports the type as follows:

---

```

val remap : r1: Rectangle -> r2: Rectangle -> (Point -> Point)

```

---

The type `Rectangle` is defined in the library `System.Drawing.dll` and represents rectangles specified by integer coordinates. The computations on the interior of the transformation are performed in floating point to improve precision. You can use this as follows:

---

```

> let mapp = remap (Rectangle(100, 100, 100, 100)) (Rectangle(50, 50, 200, 200));;
val mapp : Point -> Point
> mapp (Point(100, 100));;
val it : Point = {X=50,Y=50} {IsEmpty = false;
                          X = 50;
                          Y = 50;}
> mapp (Point(150, 150));;
val it : Point = {X=150,Y=150}
> mapp (Point(200, 200));;
val it : Point = {X=250,Y=250}

```

---

The intermediate values `scalex` and `scaley` are computed only once, despite the fact that you've called the resulting function `mapp` three times. It may be helpful to think of `mapp` as a function object being generated by the `remap` function.

In the previous example, `mapx`, `mapy`, and `mapp` are *local functions*—functions defined locally as part of the implementation of `remap`. Local functions can be context dependent—in other words, they can be defined in terms of any values and parameters that happen to be in scope. Here, `mapx` is defined in terms of `scalex`, `scaley`, `r1`, and `r2`.

---

■ **Note** Local and partially applied functions are, if necessary, implemented by taking the *closure* of the variables they depend on and storing them away until needed. In optimized F# code, the F# compiler often avoids this and instead passes extra arguments to the function implementations. Closure is a powerful technique that is used frequently in this book. It's often used in conjunction with functions, as in this chapter, but it is also used with object expressions, sequence expressions, and class definitions.

---

## Iterating with Aggregate Operators

It's common to use data to drive control. In functional programming, the distinction between data and control is often blurred: function values can be used as data, and data can influence control flow. One example is using a function such as `List.iter` to iterate over a list:

```
let sites = ["http://www.live.com";
            "http://www.google.com";
            "http://search.yahoo.com"]

sites |> List.iter (fun site -> printfn "%s, length = %d" site (http site).Length)
```

`List.iter` simply calls the given function (here an anonymous function) for each element in the input list. Many additional aggregate iteration techniques are defined in the F# and .NET libraries, particularly by using values of type `seq<type>`, discussed in “Getting Started with Sequences” later in this chapter.

## Abstracting Control with Functions

As a second example of how you can abstract control using functions, let's consider the common pattern of timing the execution of an operation (measured in wall-clock time). First, let's explore how to use `System.DateTime.Now` to get the wall-clock time:

---

```
> open System;;
> let start = DateTime.Now;;
val start : DateTime = 13/06/2012 9:54:36 p.m.
> http "http://www.newscientist.com";;
val it : string = "<!DOCTYPE html...</html>"
> let finish = DateTime.Now;;
val finish : DateTime = 13/06/2012 9:54:37 p.m.
> let elapsed = finish - start;;
val elapsed : TimeSpan = 00:00:01.1550660
```

---

Note that the type `TimeSpan` has been inferred from the use of the overloaded operator in the expression `finish - start`. Chapter 6 discusses overloaded operators in depth. You can now wrap up this technique as a function `time` that acts as a new control operator:

```
open System

let time f =
    let start = DateTime.Now
    let res = f()
    let finish = DateTime.Now
    (res, finish - start)
```

This function runs the input function `f` but takes the time on either side of the call. It then returns both the result of the function and the elapsed time. The inferred type is as follows:

---

```
val time : f:(unit -> 'a) -> 'a * TimeSpan
```

---

Here 'T is a *type variable* that stands for any type, and thus the function can be used to time functions that return any kind of result. Note that F# automatically infers a generic type for the function, a technique called *automatic generalization* that lies at the heart of F# type inference. Chapter 5 discusses automatic generalization in detail. Here is an example of using the `time` function, which again reuses the `http` function defined in Chapter 2:

---

```
> time (fun () -> http "http://www.newscientist.com");;
val it : string * TimeSpan = ... (The HTML text and time will be shown here)
```

---

## Using Object Methods as First-Class Functions

You can use existing .NET methods as first-class functions. For example:

---

```
> open System.IO;;
> [@"C:\Program Files"; @"C:\Windows"] |> List.map Directory.GetDirectories;;
val it : string [] list =
  [|"C:\Program Files\7-Zip"; "C:\Program Files\Application Verifier";
   "C:\Program Files\Common Files"; "C:\Program Files\DVD Maker";...
   "C:\Windows\Vss"; "C:\Windows\Web"; "C:\Windows\winsxs"|]
```

---

Sometimes you need to add extra type information to indicate which overload of the method is required. Chapter 6 discusses method overloading in more detail. For example, the following causes an error:

---

```
> open System;;
> let f = Console.WriteLine;;
error FS0041: A unique overload for method 'WriteLine' could not be determined based on type information prior to this program point. A type annotation may be needed.
```

---

However, the following succeeds:

---

```
> let f = (Console.WriteLine : string -> unit);;
val f : string -> unit
```

---

## Some Common Uses of Function Values

The function `remap` from the previous section generates values of type `Point -> Point`, representing “transformations for points.” You haven’t needed to define a new type for “transformations”—you just use functions as a way of modeling transformations. Many useful concepts can be modeled using function types and values. For example:

- **Actions.** The type `unit -> unit` is frequently used to model actions: operations that run and perform some unspecified side effect. For example, consider the expression `(fun () -> printfn "Hello World")`.
- **Predicates.** Types of the form `type -> bool` are frequently used to model *predicates*, which select a subset of values.
- **Counting Functions.** Types of the form `type -> int` are frequently used to model *counting functions*, which give a number for each input; the numbers may then be accumulated.
- **Statistical Functions.** Types of the form `type -> float` are frequently used to model *statistical functions*, which give a floating point number for each input. These may be used as an input into a statistical routine such `Seq.averageBy`.
- **Key Functions.** Types of the form `type -> keytype` are frequently used to model *key functions*, which give a key value for each input. For example, a key function may be an integer associated with each input. Operations such as `Seq.groupBy` and `Seq.sortBy` accept key functions.
- **Orderings.** Types of the form `type -> type -> int` are frequently used to model comparison functions over the type `type`. You also see `type * type -> int` used for this purpose, where a tuple is accepted as the first argument. In both cases, a negative result indicates less than, zero indicates equals, and a positive result indicates greater than. Operations such as `Seq.sortWith` accept ordering functions.
- **Callbacks.** Types of the form `type -> unit` are frequently used to model *callbacks*. Callbacks are often run in response to a system event, such as when a user clicks a user interface element. In this case, the parameter sent to the handler has some specific type, such as `System.Windows.Forms.MouseEventHandler`.
- **Delayed Computations.** Types of the form `unit -> type` are frequently used to model *delayed computations*, which are values that, when required, produce a value of type `type`. For example, a threading library can accept such a function value and execute it on a different thread, eventually producing a value of type `type`. Delayed computations are related to lazy computations and sequence expressions; these are discussed in “Using Sequence Expressions.”
- **Sinks.** Types of the form `type -> unit` are frequently used to model *sinks*, which are function values that, when required, consume a value of type `type`. For example, a logging API may use a sink to consume values and write them to a log file.
- **Generators.** Types of the form `int -> type` are frequently used to model *generators*, which are used to initialize a collection. The parameter may be an integer index into the collection. For example, `Array.init` accepts a generator function. More complex generators may accumulate state and optionally indicate the end of the generation process. For an example, see `Seq.unfold`.
- **Binary Operators.** Types of the form `type -> type -> type` are frequently used to model binary operations, which take two input values and combine them into one. Operations such as `List.reduce` accept binary operators.
- **Transformations.** Types of the form `type1 -> type2` are frequently used to model *transformers*, which are functions that transform each element of a collection. You see this pattern in the `map` operator for many common collection types.

- **Accumulators.** Types of the form `type1 -> type2 -> type2` are frequently used to model visitor *accumulating functions*, which are functions that visit each element of a collection (type `type1`) and accumulate a result (type `type2`). For example, a visitor function that accumulates integers into a set of integers has type `int -> Set<int> -> Set<int>`.
- 

■ **Note** The power of function types to model many different concepts is part of the enduring appeal of functional programming. This is one of the refreshing features F# brings to object-oriented programming: many simple abstractions are modeled in very simple ways and often have simple implementations through orthogonal, unified constructs, such as anonymous function values and function compositions.

---

## Summary

F# is a multiparadigm language, and this chapter looked at the core language constructs used for functional programming. The next chapter explores how to use F# for imperative programming: how to use mutable state, raise and handle exceptions, and perform I/O.

## CHAPTER 4



# Introducing Imperative Programming

In Chapter 3, you saw some of the constructs that make up F# functional programming. At the core of the functional-programming paradigm is “programming without side effects,” called pure functional programming. In this chapter you learn about programming *with* side effects, called imperative programming.

## About Functional and Imperative Programming

In the functional programming paradigm, programs compute the result of a mathematical expression and don't cause any side effects, simply returning the result of the computation. The formulas used in spreadsheets are often pure, as is the core of functional-programming languages such as Haskell.

However, F# is not a pure functional language – functions and expressions *can* have side-effects. It is very common to write pure functions and expressions in F#, but you can also write function and expression which mutate data, perform input/output, communicate over the network, start new parallel threads, and raise exceptions. These side-effects are collectively called imperative programming. The F#-type system doesn't enforce a strict distinction between expressions that perform these actions and expressions that don't.

If your primary programming experience has been with an imperative language such as C, C#, or Java, you may initially find yourself using imperative constructs fairly frequently in F#. Over time, however, F# programmers learn to perform a surprisingly large proportion of routine programming tasks within the side-effect-free subset of the language – functional programming can express an astounding range of computations succinctly and accurately. However, when you reach the limits of what functional programming can do, you will need to turn to imperative programming. In particular, F# programmers tend to use imperative programming in the following situations:

- When scripting and prototyping using F# Interactive
- When working with .NET library components that use side effects heavily, such as GUI libraries and I/O libraries
- When initializing complex data structures
- When using inherently imperative, efficient data structures, such as hash tables, hash sets and matrices
- When locally optimizing functions in a way that improves performance

- When working with very large data structures or in scenarios in which the allocation of data structures must be minimized for performance reasons

Some F# programs don't use any imperative techniques except as part of the outermost layer of their program architecture. Adopting this form of pure functional programming for a time is an excellent way to hone your functional programming techniques.

Programming with fewer side effects is attractive for many reasons. For example, eliminating unnecessary side effects nearly always reduces the complexity of your code, so it leads to fewer bugs and more rapid delivery of high-quality components. Another thing experienced functional programmers appreciate is that the programmer or compiler can easily adjust the order in which expressions are computed. If your programs don't have side effects, then it's easier to think clearly about your code: you can visually check when two programs are equivalent, and it's easier to make radical adjustments to your code without introducing new, subtle bugs. Programs that are free from side effects can often be computed on demand or in parallel, often by making very small, local changes to your code to introduce the use of delayed data structures or parallelism. Finally, mutation and other side-effects introduce complex time-dependent interactions into your code, making your code difficult to test and debug, especially when data is accessed concurrently from multiple threads, discussed further in Chapter 11.

## Imperative Looping and Iterating

The first imperative constructs you look at are those associated with looping and iteration. Three available looping constructs help simplify writing iterative code with side effects:

- Simple for loops: `for val = start-expr to end-expr do work-expr`
- Simple while loops: `while condition-expr do work-expr`
- Sequence loops: `for pattern in collection-expr do work-expr`

All three constructs are for writing imperative programs, indicated partly by the fact that in all cases the body of the loop must have a return type of `unit`. Note that `unit` is the F# type that corresponds to `void` in imperative languages, such as C, and it has the single value `()`. This means the loops don't produce a useful value, so the only use a loop can have is to perform some kind of side-effect. The following sections cover these three constructs in more detail.

### Simple for Loops

Simple for loops are used to iterate over integer ranges. This is illustrated here by a replacement implementation of the `repeatFetch` function from Chapter 2:

The first looping construct is simple for loops, which iterate over a range of integers. For example, the following construct fetched the same web page `n` times, printing the result each time:

```
let repeatFetch url n =
    for i = 1 to n do
        let html = http url
        printf "fetched << %s >>\n" html
    printf "Done!\n"
```

This loop is executed for successive values of `i` over the given range, including both start and end indexes.

## Simple While Loops

The second looping construct is a `while` loop, which repeats until a given guard is false. For example, here is a way to keep your computer busy until the weekend:

```
open System

let loopUntilSaturday() =
    while (DateTime.Now.DayOfWeek <> DayOfWeek.Saturday) do
        printf "Still working!\n"

    printf "Saturday at last!\n"
```

When executing this code in F# Interactive, you can interrupt its execution by choosing the “Cancel Interactive Evaluation” command in Visual Studio or by using `Ctrl+C` when running `fsi.exe` from the command line.

## More Iteration Loops over Sequences

As you will learn in depth in Chapter 9, any values compatible with the type `seq<type>` can be iterated using the `for pattern in seq do ...` construct. The input `seq` may be an F# list value, any `seq<type>`, or a value of any type supporting a `GetEnumerator` method. Here are some simple examples:

---

```
> for (b, pj) in [("Banana 1", false); ("Banana 2", true)] do
    if pj then
        printfn "%s is in pyjamas today!" b;;
```

*Banana 2 is in pyjamas today!*

---

The following example iterates the results of a regular expression match. The type returned by the .NET method `System.Text.RegularExpressions.Regex.Matches` is a `MatchCollection`, which, for reasons known best to the .NET designers, doesn't directly support the `seq<Match>` interface. It does, however, support a `GetEnumerator` method that permits iteration over the individual results of the operation, each of which is of type `Match`; the F# compiler inserts the conversions necessary to view the collection as a `seq<Match>` and perform the iteration. You will learn more about using the .NET Regular Expression library in Chapter 8:

---

```
> open System.Text.RegularExpressions;;
> for m in Regex.Matches("All the Pretty Horses", "[a-zA-Z]+") do
    printf "res = %s\n" m.Value;;
```

```
res = All
res = the
res = Pretty
res = Horses
```

---



## Using Mutable Records

One of the most common kinds of imperative programming is to use mutation to adjust the contents of values. Values whose contents can be adjusted are called *mutable* values. The simplest mutable values in F# are mutable records. Record types and their use in functional programming are discussed in more detail in Chapter 5. A record is mutable if one or more of its fields is labeled *mutable*. This means that record fields can be updated using the `<-` operator;—that is, the same syntax used to set a property. Mutable fields are generally used for records that implement the internal state of objects, discussed in Chapters 6 and 7.

For example, the following code defines a record used to count the number of times an event occurs and the number of times the event satisfies a particular criterion:

```
type DiscreteEventCounter =
    { mutable Total : int;
      mutable Positive : int;
      Name : string }

let recordEvent (s : DiscreteEventCounter) isPositive =
    s.Total <- s.Total+1
    if isPositive then s.Positive <- s.Positive + 1

let reportStatus (s : DiscreteEventCounter) =
    printfn "We have %d %s out of %d" s.Positive s.Name s.Total

let newCounter nm =
    { Total = 0;
      Positive = 0;
      Name = nm }
```

You can use this type as follows (this example uses the `http` function from Chapter 2):

```
let longPageCounter = newCounter "long page(s)"

let fetch url =
    let page = http url
    recordEvent longPageCounter (page.Length > 10000)
    page
```

Every call to the function `fetch` mutates the mutable-record fields in the global variable `longPageCounter`. For example:

---

```
> fetch "http://www.smh.com.au" |> ignore;;
> fetch "http://www.theage.com.au" |> ignore;;
> reportStatus longPageCounter;;
```

*We have 2 long page(s) out of 2*

---

Record types can also support members (for example, properties and methods) and give explicit implementations of interfaces, discussed in Chapter 6. When compiled, records become .NET classes and can be used from C# and other .NET languages. Practically speaking, this means you can use them as one way to implement object-oriented abstractions.

## Mutable Reference Cells

One particularly useful mutable record is the general-purpose type of mutable reference cells, or ref cells for short. These often play much the same role as pointers in other imperative programming languages. You can see how to use mutable reference cells in this example:

---

```
> let cell1 = ref 1;;
val cell1 : int ref = {contents = 1;}
> cell1.Value;;
val it : int = 1
> cell1 := 3;;
val it : unit = ()
> cell1;;
val it : int ref = {contents = 3;}
> cell1.Value;;
val it : int = 3
```

---

The type is 'T ref, and three associated functions are ref, !, and :=. The types of these are:

---

```
val ref : 'T -> 'T ref
val (:=) : 'T ref -> 'T -> unit
val (!) : 'T ref -> 'T
```

---

These allocate a reference cell, mutate the cell, and read the cell, respectively. The operation `cell1 := 3` is the key one; after this operation, the value returned by evaluating the expression `!cell1` is changed. You can also use either the `contents` field or the `Value` property to access the value of a reference cell.

Both the 'T ref type and its operations are defined in the F# library as simple record-data structures with a single mutable field:

```
type 'T ref =
    {mutable contents : 'T}
    member cell.Value = cell.contents
```

```
let (!) r = r.contents
```

```
let (:=) r v = r.contents <- v
```

```
let ref v = {contents = v}
```

The type 'T ref is a synonym for a type `Microsoft.FSharp.Core.Ref<'T>` defined in this way.

---

## WHICH DATA STRUCTURES ARE MUTABLE?

---

It's useful to know which data structures are mutable and which aren't. If a data structure can be mutated, this is typically evident in the types of operations you can perform on that structure. For example, if a data structure `Table<'Key, 'Value>` has an operation such as the following, in practice you can be sure that updates to the data structure modify the data structure itself:

```
val add : Table<'Key, 'Value> -> 'Key -> 'Value -> unit
```

That is, the updates to the data structure are destructive, and no value is returned from the operation; the result is the type `unit`, which is akin to `void` in C and many other languages. Likewise, the following member indicates that the data structure is almost certainly mutable:

```
member Add : 'Key * 'Value -> unit
```

In both cases, the presence of `unit` as a return type is a sure sign that an operation performs some side effects. In contrast, operations on immutable data structures typically return a new instance of the data structure when an operation such as `add` is performed. For example:

```
val add : 'Key -> 'Value -> Table<'Key, 'Value> -> Table<'Key, 'Value>
```

Or for example:

```
member Add : 'Key * 'Value -> Table<'Key, 'Value>
```

As discussed in Chapter 3, immutable data structures are also called functional or persistent. The latter name is used because the original table isn't modified when adding an element. Well-crafted persistent data structures don't duplicate the actual memory used to store the data structure every time an addition is made; instead, internal nodes can be shared between the old and new data structures. Example persistent data structures in the F# library are F# lists, options, tuples, and the types `Microsoft.FSharp.Collections.Map<'Key, 'Value>` and `Microsoft.FSharp.Collections.Set<'Key>`. Most data structures in the .NET libraries aren't persistent, although if you're careful, you can use them as persistent data structures by accessing them in read-only mode and copying them if necessary.

---

## Avoiding Aliasing

Like all mutable data structures, two mutable record values or two values of type `'T ref` may refer to the same reference cell—this is called *aliasing*. Aliasing of immutable data structures isn't a problem; no client consuming or inspecting the data values can detect that the values have been aliased. Aliasing of mutable data can lead to problems in understanding code, however. In general, it's good practice to ensure that no two values currently in scope directly alias the same mutable data structures. The following example continues from earlier and shows how an update to `cell1` can affect the value returned by `!cell2`:

---

```
> let cell2 = cell1;;
val cell2 : int ref = {contents = 3;}
> !cell2;;
val it : int = 3
> cell1 := 7;;
val it : unit = ()
```

```
> !cell2;;
val it : int = 7
```

---

## Hiding Mutable Data

Mutable data is often hidden behind an encapsulation boundary. Chapter 7 looks at encapsulation in more detail, but one easy way to do this is to make data private to a function. For example, the following shows how to hide a mutable reference within the inner closure of values referenced by a function value:

```
let generateStamp =
    let count = ref 0
    (fun () -> count := !count + 1; !count)
```

---

```
val generateStamp: unit -> int
```

---

The line `let count = ref 0` is executed once, when the `generateStamp` function is defined. Here is an example of the use of this function:

```
> generateStamp();;
val it : int = 1
> generateStamp();;
val it : int = 2
```

---

This is a powerful technique for hiding and encapsulating mutable state without resorting to writing new type and class definitions. It's good programming practice in polished code to ensure that all related items of mutable state are collected under some named data structure or other entity, such as a function.

---

## UNDERSTANDING MUTATION AND IDENTITY

---

F# encourages the use of objects whose logical identity (if any) is based purely on the characteristics (for example, fields and properties) of the object. For example, the identity of a pair of integers (1,2) is determined by the two integers themselves; two tuple values that each contain these two integers are, for practical purposes, identical. This is because tuples are immutable and support structural equality, hashing, and comparison, discussed further in Chapters 5 and 9.

Mutable reference cells are different; they can reveal their identities through aliasing and mutation. Not all mutable values necessarily reveal their identity through mutation, however. For example, sometimes mutation is used just to bootstrap a value into its initial configuration, such as when connecting the nodes of a graph. These are relatively benign uses of mutation.

Ultimately, you can detect whether two mutable values are the same object by using the function `System.Object.ReferenceEquals`. You can also use this function on immutable values to detect whether two values are represented by the physically same value. In this circumstance, however, the results returned by the function may change according to the optimization settings you apply to your F# code.

---

## Using Mutable Locals

You saw in the previous section that mutable references must be explicitly dereferenced. F# also supports mutable locals that are implicitly dereferenced. These must either be top-level definitions or be local variables in a function:

---

```
> let mutable cell1 = 1;;
val mutable cell1 : int = 1
> cell1;;
val it : int = 1
> cell1 <- 3;;
> cell1;;
val it : int = 3
```

---

The following shows how to use a mutable local:

```
let sum n m =
    let mutable res = 0
    for i = n to m do
        res <- res + i
    res
```

---

```
> sum 3 6;;
val it : int = 18
```

---

F# places strong restrictions on the use of mutable locals. In particular, unlike mutable references, mutable locals are guaranteed to be stack-allocated values, which is important in some situations because the .NET garbage collector won't move stack values. As a result, mutable locals may not be used in any inner anonymous functions or other closure constructs, with the exception of top-level mutable values, which can be used anywhere, and mutable fields of records and objects, which are associated with the heap-allocated objects themselves. You will learn more about mutable object types in Chapter 6. Reference cells and types containing mutable fields can be used instead to make the existence of heap-allocated imperative state obvious.

## Working with Arrays

Mutable arrays are a key data structure used as a building block in many high-performance computing scenarios. This example illustrates how to use a one-dimensional array of float values:

---

```
> let arr = [|1.0; 1.0; 1.0|];;
val arr : float [] = [|1.0; 1.0; 1.0|]
> arr.[1];;
val it : float = 1.0
```

```
> arr.[1] <- 3.0;;
> arr;;
val it : float [] = [|1.0; 3.0; 1.0|]
```

F# array values are usually manipulated using functions from the `Array` module; its full path is `Microsoft.FSharp.Collections.Array`, but you can access it with the short name `Array`. Arrays are created either by using the creation functions in that module (such as `Array.init`, `Array.create`, and `Array.zeroCreate`) or by using sequence expressions, as discussed in Chapter 9. Some useful methods are also contained in the `System.Array` class. Table 4-1 shows some common functions from the `Array` module.

*Table 4-1. Some Important Expressions, Functions, and Aggregate Operators from the Array Module*

Operator	Type	Explanation
<code>Array.append</code>	<code>'T[] -&gt; 'T[] -&gt; 'T[]</code>	Returns a new array containing elements of the first array followed by elements of the second array
<code>Array.sub</code>	<code>'T[] -&gt; int -&gt; int -&gt; 'T[]</code>	Returns a new array containing a portion of elements of the input array
<code>Array.copy</code>	<code>'T[] -&gt; 'T[]</code>	Returns a copy of the input array
<code>Array.iter</code>	<code>('T -&gt; unit) -&gt; 'T[] -&gt; unit</code>	Applies a function to all elements of the input array
<code>Array.filter</code>	<code>('T -&gt; bool) -&gt; 'T[] -&gt; 'T[]</code>	Returns a new array containing a selection of elements of the input array
<code>Array.length</code>	<code>'T[] -&gt; int</code>	Returns the length of the input array
<code>Array.map</code>	<code>('T -&gt; 'U) -&gt; 'T[] -&gt; 'U[]</code>	Returns a new array containing the results of applying the function to each element of the input array
<code>Array.fold</code>	<code>('T -&gt; 'U -&gt; 'T) -&gt; 'T -&gt; 'U[] -&gt; 'T</code>	Accumulates left to right over the input array
<code>Array.foldBack</code>	<code>('T -&gt; 'U -&gt; 'U) -&gt; 'T[] -&gt; 'U -&gt; 'U</code>	Accumulates right to left over the input array

F# arrays can be very large, up to the memory limitations of the machine (a 3GB limit applies on 32-bit systems). For example, the following creates an array of 100 million elements (of total size approximately 400MB for a 32-bit machine):

```
> let bigArray = Array.zeroCreate<int> 100000000;;
val bigArray : int [] = ...
```

The following attempt to create an array more than 4GB in size causes an `OutOfMemoryException` on one of our machines:

```
> let tooBig = Array.zeroCreate<int> 10000000000;;
System.OutOfMemoryException: Exception of type 'System.OutOfMemoryException'
was thrown.
```

---

■ **Note** Arrays of value types (such as `int`, `float32`, `float`, `int64`) are stored flat, so only one object is allocated for the entire array. Arrays of other types are stored as an array of object references. Primitive types, such as integers and floating-point numbers, are all value types; many other .NET types are also value types. The .NET documentation indicates whether each type is a value type. Often, the word `struct` is used for value types. You can also define new struct types directly in F# code, as discussed in Chapter 6. All other types in F# are reference types, such as all record, tuple, discriminated union, and class and interface values.

---

## Generating and Slicing Arrays

As you will explore in more depth in Chapter 9, you can use “sequence expressions” as a way to generate interesting array values. For example:

---

```
> let arr = [|for i in 0 .. 5 -> (i, i * i)|];;
val arr : (int * int) [] = [| (0, 0); (1, 1); (2, 4); (3, 9); (4, 16); (5, 25) |]
```

---

You can also use a convenient syntax for extracting subarrays from existing arrays; this is called *slice notation*. A slice expression for a single-dimensional array has the form `arr.[start..finish]`, where one of `start` and `finish` may optionally be omitted, and index zero or the index of the last element of the array is assumed instead. For example:

---

```
> let arr = [|for i in 0 .. 5 -> (i, i * i)|];;
val arr : (int * int) [] = [| (0, 0); (1, 1); (2, 4); (3, 9); (4, 16); (5, 25) |]
> arr.[1..3];;
val it : (int * int) [] = [| (1, 1); (2, 4); (3, 9) |]
> arr[..2];;
val it : (int * int) [] = [| (0, 0); (1, 1); (2, 4) |]
> arr.[3..];;
val it : (int * int) [] = [| (3, 9); (4, 16); (5, 25) |]
```

---

Slicing syntax is used extensively in the example “Verifying Circuits with Propositional Logic” in Chapter 12. You can also use slicing syntax with strings and several other F# types, such as vectors and matrices, and the operator can be overloaded to work with your own type definitions. The F# library definitions of vectors and matrices can be used as a guide.

---

■ **Note** Slices on arrays generate fresh arrays. Sometimes it’s more efficient to use other techniques, such as accessing the array via an accessor function or object that performs one or more internal index adjustments before looking up the underlying array. If you add support for the slicing operators to your own types, you can choose whether they return copies of data structures or an accessor object.

---

## Two-Dimensional Arrays

Like other .NET languages, F# directly supports two-dimensional array values that are stored flat—that is, where an array of dimensions (N, M) is stored using a contiguous array of  $N * M$  elements. The types for these values are written using `[, ]`, such as in `int[, ]` and `float[, ]`, and these types also support slicing syntax. Values of these types are created and manipulated using the values in the `Array2D` module. Likewise, there is a module for manipulating three-dimensional array values whose types are written `int[,,]`. You can also use the code in those modules as a template for defining code to manipulate arrays of higher dimension.

## Introducing the Imperative .NET Collections

The .NET Framework comes equipped with an excellent set of imperative collections under the namespace `System.Collections.Generic`. You've seen some of these already. The following sections look at some simple uses of these collections.

### Using Resizeable Arrays

As mentioned in Chapter 3, the .NET Framework comes with a type `System.Collections.Generic.List<'T>`, which, although named `List`, is better described as a resizeable array, and is like `std::vector<T>` in C++. The F# library includes the following type abbreviation for this purpose:

```
type ResizeArray<'T> = System.Collections.Generic.List<'T>
```

Here is a simple example of using this data structure:

---

```
> let names = new ResizeArray<string>();;
val names : ResizeArray<string>
> for name in ["Claire"; "Sophie"; "Jane"] do
    names.Add(name);;
val it : unit = ()
> names.Count;;
val it : int = 3
> names.[0];;
val it : string = "Claire"
> names.[1];;
val it : string = "Sophie"
> names.[2];;
val it : string = "Jane"
```

---

Resizeable arrays use an underlying array for storage and support constant-time random-access lookup. In many situations, this makes a resizeable array more efficient than an F# list, which supports efficient access only from the head (left) of the list. You can find the full set of members supported by this



type in the .NET documentation. Commonly used properties and members include `Add`, `Count`, `ConvertAll`, `Insert`, `BinarySearch`, and `ToArray`. A module `ResizeArray` is included in the F# library; it provides operations over this type in the style of the other F# collections.

Like other .NET collections, values of type `ResizeArray<'T>` support the `seq<'T>` interface. There is also an overload of the `new` constructor for this collection type that lets you specify initial values via a `seq<'T>`. This means you can create and consume instances of this collection type using sequence expressions:

---

```
> let squares = new ResizeArray<int>(seq {for i in 0 .. 100 -> i * i});;
val squares : ResizeArray<int>
> for x in squares do
    printfn "square: %d" x;;
square: 0
square: 1
square: 4
square: 9
...
square: 9801
square: 10000
```

---

## Using Dictionaries

The type `System.Collections.Generic.Dictionary<'Key, 'Value>` is an efficient hash-table structure that is excellent for storing associations between keys and values. Using this collection from F# code requires a little care, because it must be able to correctly hash the key type. For simple key types such as integers, strings, and tuples, the default hashing behavior is adequate. Here is a simple example:

---

```
> open System.Collections.Generic;;
> let capitals = new Dictionary<string, string>(HashIdentity.Structural);;
val capitals : Dictionary<string,string> = dict []
> capitals["USA"] <- "Washington";;
> capitals["Bangladesh"] <- "Dhaka";;
> capitals.ContainsKey("USA");;
val it : bool = true
> capitals.ContainsKey("Australia");;
val it : bool = false
> capitals.Keys;;
val it : Dictionary'2.KeyCollection<string,string> = seq ["USA"; "Bangladesh"]
> capitals["USA"];;
val it : string = "Washington"
```

---

Dictionaries are compatible with the type `seq<KeyValuePair<'key, 'value>>`, where `KeyValuePair` is a type from the `System.Collections.Generic` namespace and simply supports the properties `Key` and `Value`. Armed with this knowledge, you can use iteration to perform an operation for each element of the collection:

---

```
> for kvp in capitals do
    printf "%s has capital %s\n" kvp.Key kvp.Value;;
USA has capital Washington
Bangladesh has capital Dhaka
```

---

## Using Dictionary's TryGetValue

The `Dictionary` method `TryGetValue` is of special interest, because its use from F# is a little nonstandard. This method takes an input value of type `'Key` and looks it up in the table. It returns a `bool` indicating whether the lookup succeeded: `true` if the given key is in the dictionary and `false` otherwise. The value itself is returned via a .NET idiom called an *out parameter*. From F# code, three ways of using .NET methods rely on out parameters:

- You may use a local mutable in combination with the address-of operator `&`.
- You may use a reference cell.
- You may simply not give a parameter, and the result is returned as part of a tuple.

Here's how you do it using a mutable local:

```
open System.Collections.Generic

let lookupName nm (dict : Dictionary<string, string>) =
    let mutable res = ""
    let foundIt = dict.TryGetValue(nm, &res)
    if foundIt then res
    else failwithf "Didn't find %s" nm
```

The use of a reference cell can be cleaner. For example:

---

```
> let res = ref "";;
val res : string ref = {contents = "";}
> capitals.TryGetValue("Australia", res);;
val it : bool = false
> capitals.TryGetValue("USA", res);;
val it : bool = true
> res;;
val it : string ref = {contents = "Washington"}
```

---

Finally, with this technique you don't pass the final parameter, and instead the result is returned as part of a tuple:

---

```
> capitals.TryGetValue("Australia");;
val it : bool * string = (false, null)
> capitals.TryGetValue("USA");;
val it : bool * string = (true, "Washington")
```

---

Note that the value returned in the second element of the tuple may be null if the lookup fails when this technique is used; null values are discussed in the section “Working with null Values” in Chapter 6.

## Using Dictionaries with Compound Keys

You can use dictionaries with compound keys, such as tuple keys of type `(int * int)`. If necessary, you can specify the hash function used for these values when creating the instance of the dictionary. The default is to use generic hashing, also called *structural hashing*, a topic covered in more detail in Chapter 9. To indicate this explicitly, specify `Microsoft.FSharp.Collections.HashIdentity.Structural` when creating the collection instance. In some cases, this can also lead to performance improvements, because the F# compiler often generates a hashing function appropriate for the compound type.

This example uses a dictionary with a compound key type to represent sparse maps:

---

```
> open System.Collections.Generic;;
> open Microsoft.FSharp.Collections;;
> let sparseMap = new Dictionary<(int * int), float>();;
val sparseMap : Dictionary<(int * int),float> = dict []
> sparseMap.[(0,2)] <- 4.0;;
> sparseMap.[(1021,1847)] <- 9.0;;
> sparseMap.Keys;;
val it : Dictionary'2.KeyCollection<(int * int),float> =
  seq [(0, 2); (1021, 1847)]
```

---

## Some Other Mutable Data Structures

Some other important mutable data structures in the F# and .NET libraries are:

- `System.Collections.Generic.SortedList<'Key, 'Value>`: A collection of sorted values. Searches are done by a binary search. The underlying data structure is a single array.
- `System.Collections.Generic.SortedDictionary<'Key, 'Value>`: A collection of key/value pairs sorted by the key, rather than hashed. Searches are done by a binary search. The underlying data structure is a single array.
- `System.Collections.Generic.Stack<'T>`: A variable-sized last-in/first-out (LIFO) collection.

- `System.Collections.Generic.Queue<T>`: A variable-sized first-in/first-out (FIFO) collection.
- `System.Text.StringBuilder`: A mutable structure for building string values.
- `Microsoft.FSharp.Collections.HashSet<Key>`: A hash table structure holding only keys and no values. From .NET 3.5, a `HashSet<T>` type is available in the `System.Collections.Generic` namespace.

## Exceptions and Controlling Them

When evaluating an expression encounters a problem, it may respond in several ways: by recovering internally, emitting a warning, returning a marker value or incomplete result, or throwing an exception. The following code indicates how an exception can be thrown by some of the code you've been using:

---

```
> let req = System.Net.WebRequest.Create("not a URL");;
```

*System.UriFormatException: Invalid URI: The format of the URI could not be determined.*

---

Similarly, the `GetResponse` method also used in the `http` function may raise a `System.Net.WebException` exception. The exceptions that may be raised by routines are typically recorded in the documentation for those routines. Exception values may also be raised explicitly by F# code:

---

```
> (raise (System.InvalidOperationException("not today thank you"))) : unit;;
```

*System.InvalidOperationException: not today thank you*

---

In F#, exceptions are commonly raised using the F# `failwith` function:

---

```
> if false then 3 else failwith "hit the wall";;
```

*System.Exception: hit the wall*

---

Types of some common functions used to raise exceptions are:

---

```
val failwith : string -> 'T
val raise : System.Exception -> 'T
val failwithf : Printf.StringFormat<'T, 'U> -> 'T
val invalidArg : string -> string -> 'T
```

---

Note that the return types of all these are generic type variables: the functions never return normally and instead return by raising an exception. This means they can be used to form an expression of any particular type and can be handy when you're drafting your code. For example, in the following example, we've left part of the program incomplete:

```
if (System.DateTime.Now > failwith "not yet decided") then
    printfn "you've run out of time!"
```

Table 4-2 shows some common exceptions raised by `failwith` and other operations.

*Table 4-2. Common Categories of Exceptions and F# Functions That Raise Them*

Exception Type	F# Abbreviation	Description	Example
Exception	Failure	General failure	failwith "fail"
ArgumentException	InvalidArgument	Bad input	invalidArg "x" "y"
DivideByZeroException		Integer divide by 0	1 / 0
NullReferenceException		Unexpected null	(null : string).Length

## Catching Exceptions

You can catch exceptions using the `try ... with ...` language construct and `:?` type-test patterns, which filter any exception value caught by the `with` clause. For example:

```
try
    raise (System.InvalidOperationException ("it's just not my day"))
with
    :? System.InvalidOperationException -> printfn "caught!"
```

Giving:

---

*caught!*

---

Chapter 5 covers these patterns more closely. The following code sample shows how to use `try ... with ...` to catch two kinds of exceptions that may arise from the operations that make up the `http` method, in both cases returning the empty string `""` as the incomplete result. Note that `try ... with ...` is just an expression, and it may return a result in both branches:

```
open System.IO
```

```
let http (url : string) =
    try
        let req = System.Net.WebRequest.Create(url)
        let resp = req.GetResponse()
        let stream = resp.GetResponseStream()
        let reader = new StreamReader(stream)
        let html = reader.ReadToEnd()
        html
    with
        | :? System.UriFormatException -> ""
        | :? System.Net.WebException -> ""
```

When an exception is thrown, a value is created that records information about the exception. This value is matched against the earlier type-test patterns. It may also be bound directly and manipulated in the `with` clause of the `try ... with` constructs. For example, all exception values support the `Message` property:

```
try
    raise (new System.InvalidOperationException ("invalid operation"))
with
    err -> printfn "oops, msg = '%s'" err.Message
```

Giving:

---

```
oops, msg = 'invalid operation'
```

---

## Using try . . . finally

Exceptions may also be processed using the `try . . . finally . . .` construct. This guarantees to run the `finally` clause both when an exception is thrown and when the expression evaluates normally. This allows you to ensure that resources are disposed after the completion of an operation. For example, you can ensure that the web response from the previous example is closed as follows:

```
let httpViaTryFinally(url : string) =
    let req = System.Net.WebRequest.Create(url)
    let resp = req.GetResponse()
    try
        let stream = resp.GetResponseStream()
        let reader = new StreamReader(stream)
        let html = reader.ReadToEnd()
        html
    finally
        resp.Close()
```

In practice, you can use a shorter form to close and dispose of resources simply by using a `use` binding instead of a `let` binding if the resource implements `IDisposable`, a technique covered in Chapter 6. This closes the response at the end of the scope of the `resp` variable. Here is how the previous function looks using this form:

```
let httpViaUseBinding(url: string) =
    let req = System.Net.WebRequest.Create(url)
    use resp = req.GetResponse()
    let stream = resp.GetResponseStream()
    let reader = new StreamReader(stream)
    let html = reader.ReadToEnd()
    html
```

## Defining New Exception Types

F# lets you define new kinds of exception objects that carry data in a conveniently accessible form. For example, here is a declaration of a new class of exceptions and a function that wraps `http` with a filter that catches particular cases:

```
exception BlockedURL of string
```

```
let http2 url =
    if url = "http://www.kaos.org"
    then raise(BlockedURL(url))
    else http url
```

You can extract the information from F# exception values, again using pattern matching:

```
try
    raise(BlockedURL("http://www.kaos.org"))
```

```
with
    BlockedURL(url) -> printfn "blocked! url = '%s'" url
```

Giving:

---

```
blocked! url = 'http://www.kaos.org'
```

---

Exception values are always subtypes of the F# type `exn`, an abbreviation for the .NET type `System.Exception`. The declaration `exception BlockedURL of string` is shorthand for defining a new F# class type `BlockedURLException`, which is a subtype of `System.Exception`. Exception types can also be defined explicitly by defining new object types. Chapters 5 and 6 look more closely at object types and subtyping.

Table 4-3 summarizes the exception-related language and library constructs.

*Table 4-3. Exception-Related Language and Library Constructs*

Example Code	Kind	Notes
<code>raise expr</code>	F# library function	Raises the given exception
<code>failwith expr</code>	F# library function	Raises an <code>ArgumentException</code>
<code>try expr with rules</code>	F# expression	Catches expressions matching the pattern rules
<code>try expr finally expr</code>	F# expression	Executes the <code>finally</code> expression both when the computation is successful and when an exception is raised
<code>  :? ArgumentException -&gt;</code>	F# pattern rule	A rule matching the given .NET exception type
<code>  :? ArgumentException as e -&gt;</code>	F# pattern rule	A rule matching the given .NET exception type and naming it as its stronger type
<code>  Failure(msg) -&gt; expr</code>	F# pattern rule	A rule matching the given data-carrying F# exception
<code>  exn -&gt; expr</code>	F# pattern rule	A rule matching any exception, binding the name <code>exn</code> to the exception object value
<code>  exn when expr -&gt; expr</code>	F# pattern rule	A rule matching the exception under the given condition, binding the name <code>exn</code> to the exception object value

## Having an Effect: Basic I/O

Imperative programming and input/output are closely related topics. The following sections show some very simple I/O techniques using F# and .NET libraries.

The .NET types `System.IO.File` and `System.IO.Directory` contain a number of simple functions to make working with files easy. For example, here's a way to output lines of text to a file:

---

```
> open System.IO;;
> File.WriteAllLines("test.txt", [|"This is a test file.";
    "It is easy to read."|]);
```

---

Many simple file-processing tasks require reading all the lines of a file. You can do this by reading all the lines in one action as an array using `System.IO.File.ReadAllLines`:

---

```
> open System.IO;;
> File.ReadAllLines "test.txt";;
val it : string [] = [|"This is a test file."; "It is easy to read."|]
```

---

If necessary, the entire file can be read as a single string using `System.IO.File.ReadAllText`:

---

```
> File.ReadAllText "test.txt";;
val it : string = "This is a test file.
It is easy to read."
```

---

You can also use the method `System.IO.File.ReadLines`, which reads lines on-demand, as a sequence. This is often used as the input to a sequence expression or to a pipeline on sequence operators. For example, this;

```
seq { for line in File.ReadLines("test.txt") do
      let words = line.Split [|' '|]
      if words.Length > 3 && words.[2] = "easy" then
        yield line}
```

give results:

---

```
val it : seq<string> = seq ["It is easy to read."]
```

---

## .NET I/O via Streams

The .NET namespace `System.IO` contains the primary .NET types for reading/writing bytes and text from/to data sources. The primary output constructs in this namespace are:

- `System.IO.BinaryWriter`: Writes primitive data types as binary values. Create using `new BinaryWriter(stream)`. You can create output streams using `File.Create(filename)`.
- `System.IO.StreamWriter`: Writes textual strings and characters to a stream. The text is encoded according to a particular Unicode encoding. Create by using `new StreamWriter(stream)` and its variants or by using `File.CreateText(filename)`.
- `System.IO.StringWriter`: Writes textual strings to a `StringBuilder`, which eventually can be used to generate a string.

Here is a simple example of using `System.IO.File.CreateText` to create a `StreamWriter` and write two strings:

---

```
> let outp = File.CreateText "playlist.txt";;
val outp : StreamWriter
> outp.WriteLine "Enchanted";;
```



```
> outp.WriteLine "Put your records on";;
> outp.Close();
```

---

The primary input constructs in the `System.IO` namespace are:

- `System.IO.BinaryReader`: Reads primitive data types as binary values. When reading the binary data as a string, it interprets the bytes according to a particular Unicode encoding. Create using `new BinaryReader(stream)`.
- `System.IO.StreamReader`: Reads a stream as textual strings and characters. The bytes are decoded to strings according to a particular Unicode encoding. Create by using `new StreamReader(stream)` and its variants or by using `File.OpenText(filename)`.
- `System.IO.StringReader`: Reads a string as textual strings and characters.

Here is a simple example of using `System.IO.File.OpenText` to create a `StreamReader` and read two strings:

---

```
> let inp = File.OpenText("playlist.txt");;
val inp : StreamReader
> inp.ReadLine();;
val it : string = "Enchanted"
> inp.ReadLine();;
val it : string = "Put your records on"
> inp.Close();;
```

---

■ **Tip** In non-scripting production code, whenever you create objects such as a `StreamReader` that have a `Close` or `Dispose` operation or that implement the `IDisposable` interface, consider how to eventually close or otherwise dispose of the resource. We discuss this in Chapter 6.

---

## Some Other I/O-Related Types

The `System.IO` namespace contains a number of other types, all of which are useful for corner cases of advanced I/O but that you won't need to use from day to day. For example, these abstractions appear in the .NET documentation:

- `System.IO.TextReader`: Reads textual strings and characters from an unspecified source. This is the common functionality implemented by the `StreamReader` and `StringReader` types and the `System.Console.In` object. The latter is used to access the `stdin` input.
- `System.IO.TextWriter`: Writes textual strings and characters to an unspecified output. This is the common functionality implemented by the `StreamWriter` and

`StringWriter` types and the `System.Console.Out` and `System.Console.Error` objects. The latter are used to access the `stdout` and `stderr` output streams.

- `System.IO.Stream`: Provides a generic view of a sequence of bytes.

Some functions that are generic over different kinds of output streams make use of these; for example, the formatting function `twprintf` discussed in “Using `printf` and Friends” writes to any `System.IO.TextWriter`.

## Using `System.Console`

Some simple input/output routines are provided in the `System.Console` class. For example:

---

```
> System.Console.WriteLine "Hello World";
Hello World
> System.Console.ReadLine();
<enter "I'm still here" here>
val it : string = "I'm still here"
```

---

The `System.Console.Out` object can also be used as a `TextWriter`.

## Combining Functional and Imperative: Efficient Precomputation and Caching

All experienced programmers are familiar with the concept of *precomputation*, by which computations are performed as soon as some of the inputs to a function are known. The following sections cover a number of manifestations of precomputation in F# programming and the related topics of memoization and caching. These represent one common pattern in which imperative programming is used safely and non-intrusively within a broader setting of functional programming.

### Precomputation and Partial Application

Let's say you're given a large input list of words and you want to compute a function that checks whether a word is in this list. Do this:

```
let isWord (words : string list) =
    let wordTable = Set.ofList words
    fun w -> wordTable.Contains(w)
```

Here, `isWord` has the following type:

---

```
val isWord : words:string list -> (string -> bool)
```

---

The efficient use of this function depends crucially on the fact that useful intermediary results are computed after only one argument is applied and a function value is returned. For example:

---

```

> let isCapital = isWord ["London"; "Paris"; "Warsaw"; "Tokyo"];
val isCapital : (string -> bool)
> isCapital "Paris";
val it : bool = true
> isCapital "Manchester";
val it : bool = false

```

---

Here, the internal table `wordTable` is computed as soon as `isCapital` is applied to one argument. It would be a mistake to write `isCapital` as:

```
let isCapitalSlow inp = isWord ["London"; "Paris"; "Warsaw"; "Tokyo"] inp
```

This function computes the same results as `isCapital`. It does so inefficiently, however, because `isWord` is applied to both its first argument and its second argument every time you use the function `isCapitalSlow`. This means the internal table is rebuilt every time the function `isCapitalSlow` is applied, somewhat defeating the point of having an internal table in the first place. In a similar vein, the definition of `isCapital` shown previously is more efficient than either `isCapitalSlow2` or `isCapitalSlow3` in the following:

```
let isWordSlow2 (words : string list) (word : string) =
    List.exists (fun word2 -> word = word2) words
```

```
let isCapitalSlow2 word = isWordSlow2 ["London"; "Paris"; "Warsaw"; "Tokyo"] word
```

```
let isWordSlow3 (words : string list) (word : string) =
    let wordTable = Set<string>(words)
    wordTable.Contains(word)
```

```
let isCapitalSlow3 word = isWordSlow3 ["London"; "Paris"; "Warsaw"; "Tokyo"] word
```

The first uses an inappropriate data structure for the lookup (an F# list, which has  $O(n)$  lookup time), and the second attempts to build a better intermediate data structure (an F# set, which has  $O(\log n)$  lookup time) but does so on every invocation.

There are often trade-offs among different intermediate data structures or whether to use them at all. For example, in the previous example, you could just as well use a `HashSet` as the internal data structure. This approach, in general, gives better lookup times (constant time), but it requires slightly more care to use, because a `HashSet` is a mutable data structure. In this case, you don't mutate the data structure after you create it, and you don't reveal it to the outside world, so it's entirely safe:

```
let isWord (words : string list) =
    let wordTable = HashSet<string>(words)
    fun word -> wordTable.Contains word
```

## Precomputation and Objects

The examples of precomputation given previously are variations on the theme of computing functions, introduced in Chapter 3. The functions computed capture the precomputed intermediate data structures. It's clear, however, that precomputing via partial applications and functions can be subtle, because it

matters when you apply the first argument of a function (triggering the construction of intermediate data structures) and when you apply the subsequent arguments (triggering the real computation that uses the intermediate data structures).

Luckily, functions don't just have to compute functions; they can also return more sophisticated values, such as objects. This can help make it clear when precomputation is being performed. It also allows you to build richer services based on precomputed results. For example, Listing 4-1 shows how to use precomputation as part of building a name-lookup service. The returned object includes both a `Contains` method and a `ClosestPrefixMatch` method.

*Listing 4-1. Precomputing a Word Table Before Creating an Object*

```
open System

type NameLookupService =
    abstract Contains : string -> bool

let buildSimpleNameLookup (words : string list) =
    let wordTable = HashSet<_>(words)
    {new NameLookupService with
        member t.Contains w = wordTable.Contains w}
```

The internal data structure used in Listing 4-1 is the same as before: an F# set of type `Microsoft.FSharp.Collections.Set<string>`. The service can now be instantiated and used as follows:

---

```
> let capitalLookup = buildSimpleNameLookup ["London"; "Paris"; "Warsaw"; "Tokyo"];;
val capitalLookup : NameLookupService
> capitalLookup.Contains "Paris";;
val it : bool = true
```

---

In passing, note the following about this implementation:

- You can extend the returned service to support a richer set of queries of the underlying information by adding further methods to the object returned.

Precomputation of the kind used previously is an essential technique for implementing many services and abstractions, from simple functions to sophisticated computation engines. You see further examples of these techniques in Chapter 9.

## Memoizing Computations

Precomputation is one important way to amortize the costs of computation in F#. Another is called *memoization*. A memoizing function avoids recomputing its results by keeping an internal table, often called a *lookaside table*. For example, consider the well-known Fibonacci function, whose naive, unmemoized version is:

```
let rec fib n = if n <= 2 then 1 else fib (n - 1) + fib (n - 2)
```

Not surprisingly, a version keeping a lookaside table is much faster:

```
let fibFast =
    let t = new System.Collections.Generic.Dictionary<int, int>()
```

```

let rec fibCached n =
    if t.ContainsKey n then t.[n]
    elif n <= 2 then 1
    else let res = fibCached (n - 1) + fibCached (n - 2)
         t.Add (n, res)
         res
fun n -> fibCached n

// From Chapter 2, but modified to use stop watch.
let time f =
    let sw = System.Diagnostics.Stopwatch.StartNew()
    let res = f()
    let finish = sw.Stop()
    (res, sw.Elapsed.TotalMilliseconds |> sprintf "%f ms")

time(fun () -> fibFast 30)
time(fun () -> fibFast 30)
time(fun () -> fibFast 30)

```

---

```

val fibFast : (int -> int)
val time : f:(unit -> 'a) -> 'a * string
val it : int * string = (832040, "0.727200 ms")
val it : int * string = (832040, "0.066100 ms")
val it : int * string = (832040, "0.077400 ms")

```

---

On one of our laptops, with  $n = 30$ , there's an order of magnitude speed up from the first to second run. Listing 4-2 shows how to write a generic function that encapsulates the memoization technique.

#### Listing 4-2. A Generic Memoization Function

```

open System.Collections.Generic

let memoize (f : 'T -> 'U) =
    let t = new Dictionary<'T, 'U>(HashIdentity.Structural)
    fun n ->
        if t.ContainsKey n then t.[n]
        else let res = f n
             t.Add (n, res)
             res

let rec fibFast =
    memoize (fun n -> if n <= 2 then 1 else fibFast (n - 1) + fibFast (n - 2))

```

Here, the functions have the types:

---

```

val memoize : f:( 'T -> 'U) -> ( 'T -> 'U) when 'T : equality
val fibFast : (int -> int)

```

---

In the definition of `fibFast`, you use `let rec` because `fibFast` is self-referential—that is, used as part of its own definition. You can think of `fibFast` as a *computed, recursive* function. Such a function generates an

informational warning when used in F# code, because it's important to understand when this feature of F# is being used; you then suppress the warning with `#nowarn "40"`. As with the examples of computed functions from the previous section, omit the extra argument from the application of `memoize`, because including it would lead to a fresh memoization table being allocated each time the function `fibNotFast` was called:

```
let rec fibNotFast n =
    memoize (fun n -> if n <= 2 then 1 else fibNotFast (n - 1) + fibNotFast (n - 2)) n
```

Due to this subtlety, it's often a good idea to define your memoization strategies to generate objects other than functions (think of functions as very simple kinds of objects). For example, Listing 4-3 shows how to define a new variation on `memoize` that returns a `Table` object that supports both a lookup and a `Discard` method.

**Listing 4-3.** *A Generic Memoization Service*

```
open System.Collections.Generic

type Table<'T, 'U> =
    abstract Item : 'T -> 'U with get
    abstract Discard : unit -> unit

let memoizeAndPermitDiscard f =
    let lookasideTable = new Dictionary<_, _>(HashIdentity.Structural)
    {new Table<'T, 'U> with
        member t.Item
            with get(n) =
                if lookasideTable.ContainsKey(n)
                then lookasideTable.[n]
                else let res = f n
                     lookasideTable.Add(n, res)
                     res

        member t.Discard() =
            lookasideTable.Clear()}}

#nowarn "40" // do not warn on recursive computed objects and functions

let rec fibFast =
    memoizeAndPermitDiscard
        (fun n ->
            printfn "computing fibFast %d" n
            if n <= 2 then 1 else fibFast.[n - 1] + fibFast.[n - 2])
```

In Listing 4-3, `lookup` uses the `a.[b]` associative `Item` lookup property syntax, and the `Discard` method discards any internal partial results. The functions have these types:

---

```
val memoizeAndPermitDiscard : ('T -> 'U) -> Table<'T, 'U> when 'T : equality
val fibFast : Table<int,int>
```

---

This example shows how `fibFast` caches results but recomputes them after a `Discard`:

---

```

> fibFast.[3];;
computing fibFast 3
computing fibFast 2
computing fibFast 1
val it : int = 2

> fibFast.[5];;
computing fibFast 5
computing fibFast 4
val it : int = 5

> fibFast.Discard();;
> fibFast.[5];;
computing fibFast 5
computing fibFast 4
computing fibFast 3
computing fibFast 2
computing fibFast 1
val it : int = 5

```

---

■ **Note** Memoization relies on the memoized function being stable and idempotent. In other words, it always returns the same results, and no additional interesting side effects are caused by further invocations of the function. In addition, memoization strategies rely on mutable internal tables. The implementation of `memoize` shown in this chapter isn't thread safe, because it doesn't lock this table during reading or writing. This is fine if the computed function is used only from at most one thread at a time, but in a multithreaded application, use memoization strategies that use internal tables protected by locks, such as a `.NET ReaderWriterLock`. Chapter 11 further discusses thread synchronization and mutable state.

---

## Lazy Values

Memoization is a form of *caching*. Another important variation on caching is a simple *lazy* value, a delayed computation of type `Microsoft.FSharp.Control.Lazy<'T>` for some type `'T`. Lazy values are usually formed by using the special keyword `lazy` (you can also make them explicitly using the functions in the `Microsoft.FSharp.Core.Lazy` module). For example:

---

```

> let sixty = lazy (30 + 30);;
val sixty : Lazy<int> = Value is not created.
> sixty.Force();;
val it : int = 60

```

---

Lazy values of this kind are implemented as thunks holding either a function value that computes the result or the actual computed result. The lazy value is computed only once, and thus its effects are executed only once. For example, in the following code fragment, “Hello world” is printed only once:

---

```
> let sixtyWithSideEffect = lazy (printfn "Hello world"; 30 + 30);;
val sixtyWithSideEffect: Lazy<int> = Value is not created.
> sixtyWithSideEffect.Force();;
Hello world
val it : int = 60
> sixtyWithSideEffect.Force();;
val it : int = 60
```

---

Lazy values are implemented by a simple data structure containing a mutable reference cell. The definition of this data structure is in the F# library source code.

## Other Variations on Caching and Memoization

You can apply many different caching and memoization techniques in advanced programming, and this chapter can't cover them all. Some common variations are:

- Using an internal data structure that records only the last invocation of a function and basing the lookup on a very cheap test on the input.
- Using an internal data structure that contains both a fixed-size queue of input keys and a dictionary of results. Entries are added to both the table and the queue as they're computed. When the queue is full, the input keys for the oldest computed results are dequeued, and the computed results are discarded from the dictionary.

## Combining Functional and Imperative: Functional Programming with Side Effects

F# stems from a tradition in programming languages in which state is made explicit, largely by passing extra parameters. Many F# programmers use functional-programming techniques first before turning to their imperative alternatives, and we encourage you to do the same, for all the reasons listed at the start of this chapter.

F# also integrates imperative and functional programming together in a powerful way. F# is actually an extremely succinct imperative-programming language! Furthermore, in some cases, no good functional techniques exist to solve a problem, or those that do are too experimental for production use. This means that in practice, using imperative constructs and libraries is common in F#. For example, many examples you saw in Chapters 2 and 3 used side effects to report their results or to create GUI components.

Regardless, we still encourage you to think functionally, even about your imperative programming. In particular, it's always helpful to be aware of the potential side effects of your overall program and the characteristics of those side effects. The following sections describe five ways to help tame and reduce the use of side effects in your programs.



## Consider Replacing Mutable Locals and Loops with Recursion

When imperative programmers begin to use F#, they frequently use mutable local variables or reference cells heavily as they translate code fragments from their favorite imperative language into F#. The resulting code often looks very bad. Over time, programmers learn to avoid many uses of mutable locals. For example, consider this (naive) implementation of factorization, transliterated from C code:

```
let factorizeImperative n =
    let mutable factor1 = 1
    let mutable factor2 = n
    let mutable i = 2
    let mutable fin = false
    while (i < n && not fin) do
        if (n % i = 0) then
            factor1 <- i
            factor2 <- n / i
            fin <- true
        i <- i + 1
```

```
if (primefactor1 = 1) then None
else Some (primefactor1, primefactor2)
```

This code can be replaced by use of an inner recursive function:

```
let factorizeRecursive n =
    let rec find i =
        if i >= n then None
        elif (n % i = 0) then Some(i, n / i)
        else find (i + 1)
    find 2
```

The second code is not only shorter but also uses no mutation, which makes it easier to reuse and maintain. You can also see that the loop terminates (*i* is increasing toward *n*) and see the two exit conditions for the function (*i* >= *n* and *n* % *i* = 0). Note that the state *i* has become an explicit parameter.

## Separating Pure Computation from Side-Effecting Computations

Where possible, separate out as much of your computation as possible using side-effect-free functional programming. For example, sprinkling `printf` expressions throughout your code may make for a good debugging technique but, if not used wisely, it can lead to code that is difficult to understand and inherently imperative.

## Separating Mutable Data Structures

A common technique of object-oriented programming is to ensure that mutable data structures are private, and where possible, fully separated, which means there is no way that distinct pieces of code can access one another's internal state in undesirable ways. Fully separated state can even be used inside the implementation of what, to the outside world, appears to be a purely functional piece of code.

For example, where necessary, you can use side effects on private data structures allocated at the start of an algorithm and then discard these data structures before returning a result; the overall result is then effectively a side-effect-free function. One example of separation from the F# library is the library's

implementation of `List.map`, which uses mutation internally; the writes occur on an internal, separated data structure that no other code can access. Thus, as far as callers are concerned, `List.map` is pure and functional.

This second example divides a sequence of inputs into equivalence classes (the F# library function `Seq.groupBy` does a similar thing):

```
open System.Collections.Generic

let divideIntoEquivalenceClasses keyf seq =

    // The dictionary to hold the equivalence classes
    let dict = new Dictionary<'key, ResizeArray<'T>>()

    // Build the groupings
    seq |> Seq.iter (fun v ->
        let key = keyf v
        let ok, prev = dict.TryGetValue(key)
        if ok then prev.Add(v)
        else let prev = new ResizeArray<'T>()
             dict.[key] <- prev
             prev.Add(v))

    // Return the sequence-of-sequences. Don't reveal the
    // internal collections: just reveal them as sequences
    dict |> Seq.map (fun group -> group.Key, Seq.readonly group.Value)
```

This uses the `Dictionary` and `ResizeArray` mutable data structures internally, but these mutable data structures aren't revealed externally. The inferred type of the overall function is:

---

```
val divideIntoEquivalenceClasses :
  keyf:('T -> 'key) -> seq:seq<'T> -> seq<'key * seq<'T>> when 'key : equality
```

---

Here is an example use:

---

```
> divideIntoEquivalenceClasses (fun n -> n % 3) [0 .. 10];;
val it : seq<int * seq<int>>
= seq [(0, seq [0; 3; 6; 9]); (1, seq [1; 4; 7; 10]); (2, seq [2; 5; 8])]
```

---

## Not All Side Effects Are Equal

It's often helpful to use the weakest set of side effects necessary to achieve your programming task and at least be aware when you're using strong side effects:

- Weak side effects are effectively benign, given the assumptions you're making about your application. For example, writing to a log file is very useful and essentially benign (if the log file can't grow arbitrarily large and crash your machine!). Similarly, reading data from a stable, unchanging file store on a local disk is effectively treating

the disk as an extension of read-only memory, so reading these files is a weak form of side effect that isn't difficult to incorporate into your programs.

- Strong side effects have a much more corrosive effect on the correctness and operational properties of your program. For example, blocking network I/O is a relatively strong side effect by any measure. Performing blocking network I/O in the middle of a library routine can destroy the responsiveness of a GUI application, at least if the routine is invoked by the GUI thread of an application. Any constructs that perform synchronization between threads are also a major source of strong side effects.

Whether a particular side effect is stronger or weaker depends on your application and whether the consequences of the side effect are sufficiently isolated and separated from other entities. Strong side effects can and should be used freely in the outer shell of an application or when you're scripting with F# Interactive; otherwise, not much can be achieved.

When you're writing larger pieces of code, write your application and libraries in such a way that most of your code either doesn't use strong side effects or at least makes it obvious when these side effects are being used. Threads and concurrency are commonly used to mediate problems associated with strong side effects. Chapter 11 covers these issues in more depth.

## Avoid Combining Imperative Programming and Laziness

It's generally thought to be bad style to combine delayed computations (that is, laziness) and side effects. This isn't entirely true; for example, it's reasonable to set up a read from a file system as a lazy computation using sequences. It's relatively easy to make mistakes in this sort of programming, however. For example, consider:

```
open System.IO
let reader1, reader2 =
    let reader = new StreamReader(File.OpenRead("test.txt"))
    let firstReader() = reader.ReadLine()
    let secondReader() = reader.ReadLine()

    // Note: we close the stream reader here!
    // But we are returning function values which use the reader
    // This is very bad!
    reader.Close()
    firstReader, secondReader

// Note: stream reader is now closed! The next line will fail!
let firstLine = reader1()
let secondLine = reader2()
firstLine, secondLine
```

This code is wrong, because the `StreamReader` object `reader` is used after the point indicated by the comment. The returned function values are then called, and they try to read from the captured variable `reader`. Function values are just one example of delayed computations; others are lazy values, sequences, and any objects that perform computations on demand. Avoid building delayed objects such as `reader` that represent handles to transient, disposable resources, unless those objects are used in a way that respects the lifetime of that resource.

The previous code can be corrected to avoid using laziness in combination with a transient resource:

```
open System.IO

let line1, line2 =
    let reader = new StreamReader(File.OpenRead("test.txt"))
    let firstLine = reader.ReadLine()
    let secondLine = reader.ReadLine()
    reader.Close()
    firstLine, secondLine
```

Another technique uses language and/or library constructs that tie the lifetime of an object to some larger object. For example, you can use a use binding within a sequence expression, which augments the sequence object with the code needed to clean up the resource when iteration is finished or terminates. This technique, discussed further in Chapter 9, is shown by example here (see also the `System.IO.File.ReadLines`, which serves a similar role):

```
let linesOfFile =
    seq {use reader = new StreamReader(File.OpenRead("test.txt"))
        while not reader.EndOfStream do
            yield reader.ReadLine()}
```

The general lesson is to minimize the side effects you use, and to use separated, isolated state where possible. Orchestrating compositional, separated objects using functional programming as the orchestration language is often a highly effective technique. Use both delayed computations (laziness) and imperative programming (side effects) where appropriate, but be careful about using them together.

## Summary

In this chapter, you learned how to do imperative programming in F#, from some of the basic mutable data structures, such as reference cells, to working with side effects, such as exceptions and I/O. You also looked at some general principles for avoiding the need for imperative programming and isolating your uses of side effects. The next chapter continues to explore some building-blocks of typed functional programming in F#, with a deeper look at types, type inference, and generics.

## CHAPTER 5



# Understanding Types in Functional Programming

F# is a typed language, and F# programmers often use types in sophisticated ways. In this chapter, you learn about the foundations of types, focusing on how types are defined and used in F# functional programming. You also look closely at *generics*, and closely related to generics is the notion of *subtyping*. Generics and subtyping combine to allow you to write code that is generic over families of types. You will see how F# uses *automatic generalization* to automatically infer generic types for your code, and the chapter covers some of the basic generic functions in the F# libraries, such as generic comparison, hashing, and binary serialization.

## Exploring Some Simple Type Definitions

Given that F# is a typed language, you will often need to declare new shapes of types via type definitions and type abbreviations. This chapter covers only some of the simpler type definitions that are useful and succinct workhorses for functional programming. F# also lets you define a range of sophisticated type definitions related to object-oriented programming, discussed in Chapter 6. Often, however, these aren't required in basic functional programming.

## Defining Type Abbreviations

Type abbreviations are the simplest type definitions:

```
type index = int
type flags = int64
type results = string * System.TimeSpan * int * int
```

It's common to use lowercase names for type abbreviations, but it's certainly not compulsory. Type abbreviations aren't concrete, because they simply alias an existing type. For example, when doing .NET programming with F#, they're expanded during the process of compiling F# code to the format shared among multiple .NET languages. Because of this, a number of restrictions apply to type abbreviations. For example, you can't augment them with additional members, as can be done for concrete types, such as

records, discriminated unions, and classes. In addition, you can't truly hide a type abbreviation using a signature (see Chapter 7).

## Defining Record Types

The simplest concrete type definitions are records. Here's an example:

```
type Person =
  {Name : string
   DateOfBirth : System.DateTime}
```

You can construct record values by using the record labels:

---

```
> {Name = "Bill"; DateOfBirth = new System.DateTime(1962, 09, 02)};;
val it : Person = {Name="Bill"; DateOfBirth = 09/02/1962 ...}
```

---

Here, semicolons are used to separate each field, which are optional in the longer, one-field-per-line form above. Should there be a conflict between labels among multiple records, you can also construct record values by using an explicit type annotation:

---

```
> ({Name = "Anna"; DateOfBirth = new System.DateTime(1968, 07, 23)} : Person);;
val it : Person = {Name="Anna"; DateOfBirth = 23/07/1968 ... }
```

---

Other times, referencing the containing type for any given record label using the `type.field` syntax helps to avoid conflicts. Record values are often used to return results from functions:

```
type PageStats =
  {Site : string;
   Time : System.TimeSpan;
   Length : int;
   NumWords : int;
   NumHRefs : int}
```

This technique works well when returning a large number of heterogeneous results:

```
//Using the time, http and getWords functions from Chapter 3.
let stats site =
  let url = "http://" + site
  let html, t = time (fun () -> http url)
  let words = html |> getWords
  let hrefs = words |> Array.filter (fun s -> s = "href")
  {Site = site; Time = t; Length = html.Length;
   NumWords = words.Length; NumHRefs = hrefs.Length}
```

Here is the type of stats:

---

```
val stats : site:string -> PageStats
```

---

Here is how F# Interactive shows the results of applying the function:

---

```
> stats "www.live.com";;

val it : PageStats = {Site = "www.live.com";
                      Time = 00:00:03.0941770 {Days = 0; ...};
                      Length = 12139;
                      NumWords = 892;
                      NumHRefs = 11;}
```

---

## Handling Non-Unique Record Field Names

Record labels need not be unique among multiple record types. Here is an example:

```
type Person =
  {Name : string
   DateOfBirth : System.DateTime}
type Company =
  {Name : string
   Address : string}
```

When record names are non-unique, constructions of record values may need to use object expressions in order to indicate the name of the record type, thus disambiguating the construction. For example, consider the following type definitions:

```
type Dot = {X : int; Y : int}
type Point = {X : float; Y : float}
```

On lookup, record labels are accessed using the dot (.) notation in the same way as properties. One slight difference is that in the absence of further qualifying information, the type of the object being accessed is inferred from the record label. This is based on the latest set of record labels in scope from record definitions and uses of open. For example, given the previous definitions, you have the following:

---

```
> let coords1 (p:Point) = (p.X, p.Y);;
val coords1 : p:Point -> float * float
> let coords2 (d:Dot) = (d.X, d.Y);;
val coords2 : d:Dot -> int * int
> let dist p = sqrt (p.X * p.X + p.Y * p.Y);; // use of X and Y implies type "Point"
val dist : p:Point -> float
```

---

The accesses to the labels X and Y in the first two definitions have been resolved using the type information provided by the type annotations. The accesses in the third definition have been resolved using the default interpretation (taking the last definition that fits) of record field labels in the absence of any other qualifying information.

## Cloning Records

Records support a convenient syntax to clone all the values in the record, creating a new value with some values replaced. Here is a simple example:

```
type Point3D = {X : float; Y : float; Z : float}

let p1 = {X = 3.0; Y = 4.0; Z = 5.0}
let p2 = {p1 with Y = 0.0; Z = 0.0} val p1 : Point3D = {X = 3.0; Y = 4.0; Z = 5.0;}
```

---

```
val p2 : Point3D = {X = 3.0; Y = 0.0; Z = 0.0;}
```

---

The definition of `p2` is identical to this:

```
let p2 = {X = 3.0; Y = 0.0; Z = 0.0}
```

This expression form doesn't mutate the values of a record, even if the fields of the original record are mutable.

## Defining Discriminated Unions

The second kind of concrete type definition discussed in this section is a discriminated union. Here is a very simple example:

```
type Route = int
type Make = string
type Model = string
type Transport =
  | Car of Make * Model
  | Bicycle
  | Bus of Route
```

Each alternative of a discriminated union is called a *discriminator*. You can build values by using the discriminator much as if it were a function:

---

```
> let ian = Car("BMW", "360");;
val ian : Transport = Car ("BMW", "360")
> let don = [Bicycle; Bus 8];;
val don : Transport list = [Bicycle; Bus 8]
> let peter = [Car ("Ford", "Fiesta"); Bicycle];;
val peter : Transport list = [Car ("Ford", "Fiesta"); Bicycle];;
```

---

You can also use discriminators in pattern matching:

```
let averageSpeed (tr : Transport) =
```



```
match tr with
| Car _ -> 35
| Bicycle -> 16
| Bus _ -> 24
```

Discriminated unions can include recursive references (the same is true of records and other type definitions). This is frequently used when representing structured languages via discriminated unions, a topic covered in depth in Chapter 9:

```
type Proposition =
| True
| And of Proposition * Proposition
| Or of Proposition * Proposition
| Not of Proposition
```

Recursive functions can be used to traverse such a type. For example:

```
let rec eval (p : Proposition) =
match p with
| True -> true
| And(p1,p2) -> eval p1 && eval p2
| Or (p1,p2) -> eval p1 || eval p2
| Not(p1) -> not (eval p1)
```

Several of the types you've already met are defined as discriminated unions. For example, the 'T option type and the F# type of immutable lists are effectively defined as:

```
type 'T option =
| None
| Some of 'T

type 'T list =
| ([])
| (:::) of 'T * 'T list
```

A broad range of tree-like data structures are conveniently represented as discriminated unions. For example:

```
type Tree<'T> =
| Tree of 'T * Tree<'T> * Tree<'T>
| Tip of 'T
```

You can use recursive functions to compute properties of trees:

```
let rec sizeOfTree tree =
match tree with
| Tree(_, l, r) -> 1 + sizeOfTree l + sizeOfTree r
| Tip _ -> 1
```

Here is the inferred type of sizeOfTree:

---

```
val sizeOfTree : tree:Tree<'a> -> int
```

---

Here is an example of a constructed tree term and the use of the size function:

---

```
> let smallTree = Tree ("1", Tree ("2", Tip "a", Tip "b"), Tip "c");;
val smallTree : Tree<string> = Tree ("1",Tree ("2",Tip "a",Tip "b"),Tip "c")
> sizeOfTree smallTree;;
val it : int = 5
```

---

Chapters 9 and 12 discuss symbolic manipulation based on trees.

---

■ **Note** Discriminated unions are a powerful and important construct and are useful when modeling a finite, sealed set of choices. This makes them a perfect fit for many constructs that arise in applications and symbolic analysis libraries. They are, by design, nonextensible: subsequent modules can't add new cases to a discriminated union. This is deliberate: you get strong and useful guarantees by placing a limit on the range of possible values for a type.

---

## Using Discriminated Unions as Records

Discriminated union types with only one data tag are an effective way to implement record-like types:

```
type Point3D = Vector3D of float * float * float
```

```
let origin = Vector3D(0., 0., 0.)
let unitX = Vector3D(1., 0., 0.)
let unitY = Vector3D(0., 1., 0.)
let unitZ = Vector3D(0., 0., 1.)
```

These are particularly effective because they can be decomposed using succinct patterns in the same way as tuple arguments:

```
let length (Vector3D(dx, dy, dz)) = sqrt(dx * dx + dy * dy + dz * dz)
```

This technique is most useful for record-like values where there is some natural order on the constituent elements of the value (as shown earlier) or where the elements have different types.

It might also be helpful to be aware that when pattern matching against single-case discriminated union values in a match construct, the use of the pipe `|` operator is optional. This is also the case above, in the type definition.

## Defining Multiple Types Simultaneously

Multiple types can be declared together to give a mutually recursive collection of types, including record types, discriminated unions, and abbreviations. The type definitions must be separated by the keyword `and`:

```
type Node =
  {Name : string;
   Links : Link list}and Link =
  | Dangling
  | Link of Node
```

## Understanding Generics

F# constructs such as lists, tuples, and function values are all *generic*, which means they can be instantiated with multiple different types. For example, `int list`, `string list`, and `(int * int) list` are all instantiations of the generic family of F# list types. Likewise, `int -> int` and `string -> int` are both instantiations of the generic family of F# function types. The F# library and the .NET Framework have many other generic types and operations in addition to these.

Generic constructs are always represented through the use of *type variables*, which in F# syntax are written 'T, 'U, 'a, 'Key, and so on. For example, the definition of the `Set` type in the F# library begins like this:

```
type Set<'T> = ...
```

Type abbreviations can also be generic, e.g.

```
type StringMap<'T> = Map<string, 'T>
type Projections<'T, 'U> = ('T -> 'U) * ('U -> 'T)
```

Values can also be generic. A typical generic value is `List.map`, whose type is as follows:

---

```
val map : ('T -> 'U) -> 'T list -> 'U list
```

---

Each time you name a generic type or value, the F# type system must infer instantiations for the type variables involved. For example, in Chapter 3, you used `List.map` `fetch` over an input list, where `fetch` had the following type:

---

```
val fetch : url:string -> string * string
```

---

In this case, the type variable 'T in the signature of `List.map` is instantiated to `string`, and the type variable 'U is instantiated to `string * string`, giving a return type of `(string * string) list`.

Generic values and functions such as `List.map` are common in F# programming; they're so common that you usually don't even write the declarations of the type variables in the types of these values. Sometimes, however, the declaration point of these variables is made explicit in output from tools and the F# compiler. For example, you may see this:

---

```
val map<'T, 'U> : ('T -> 'U) -> 'T list -> 'U list
```

---

Frequently, type variables have an implicit scope, governed by the rules of automatic generalization discussed in the section “Writing Generic Functions.” This means you can introduce type variables simply by writing them as part of the type annotations of a function:

```
let rec map (f : 'T -> 'U) (l : 'T list) =
    match l with
    | h :: t -> f h :: map f t
    | [] -> []
```

If you want, you can also write the type parameters explicitly on a declaration. You typically have to use each type variable at least once in a type annotation in order to relate the type parameters to the actual code:

```
let rec map<'T, 'U> (f : 'T -> 'U) (l : 'T list) =
    match l with
    | h :: t -> f h :: map f t
    | [] -> []
```

---

■ **Note** By convention, uppercase type-variable names are used for user-declared type parameters, and lowercase names are used for inferred type parameters. In general, the style *TypeName*<'T> is preferred for F# types, although for historical reasons, the style 'T *TypeName* is used for list, option, reference, and array types.

---

## Writing Generic Functions

A key feature of F# is the automatic generalization of code. The combination of automatic generalization and type inference makes many programs simpler, more succinct, and more general. It also greatly enhances code reuse. Languages without automatic generalization force programmers to compute and explicitly write down the most general type of their functions, and often this is so tedious that programmers don't take the time to abstract common patterns of data manipulation and control.

For example, type parameters are automatically introduced when you write simple functions that are independent of some of their arguments:

```
let getFirst (a,b,c) = a
```

The inferred type of `getFirst` is reported as follows:

---

```
val getFirst : a:'a * b:'b * c:'c -> 'a
```

---

Here, `getFirst` has been *automatically inferred to be generic*. The function is generic in three type variables, where the result type is the first element of the input tuple type. Automatic generalization is applied when a `let` or `member` definition doesn't fully constrain the types of inputs or outputs. You can tell automatic generalization has been applied by the presence of type variables in an inferred type and ultimately by the fact that you can reuse a construct with multiple types.

Automatic generalization is particularly useful when taking functions as inputs. For example, the following takes two functions as input and applies them to each side of a tuple:

```
let mapPair f g (x, y) = (f x, g y)
```

The generalized, inferred type is as follows:

---

```
val mapPair : f:(('a -> 'b) -> g:(('c -> 'd) -> x:'a * y:'c -> 'b * 'd
```

---

## Some Important Generic Functions

The F# and .NET libraries include definitions for some important generic functions. You saw a number of these in action in earlier chapters. It's important to have a working knowledge of these building blocks, because often your code will automatically become generic when you use these primitives.

## Generic Comparison

The first primitives are all related to *generic comparison*, also often called *structural comparison*. Every time you use operators such as <, >, <=, >=, =, <>, compare, min, and max in F# code, you're using generic comparison. All of these operators are located in the Microsoft.FSharp.Core.Operators module, which is opened by default in all F# code. Some important data structures also use generic comparison internally; for example, you may also be using generic comparison when you use F# collection types such as Microsoft.FSharp.Collections.Set and Microsoft.FSharp.Collections.Map. This is discussed in the documentation for these types. The type signatures of the basic generic comparison operators are shown here:

---

```
val compare : 'T -> 'T -> int when 'T : comparison
val (=) : 'T -> 'T -> bool when 'T : equality
val (<) : 'T -> 'T -> bool when 'T : comparison
val (<=) : 'T -> 'T -> bool when 'T : comparison
val (>) : 'T -> 'T -> bool when 'T : comparison
val (>=) : 'T -> 'T -> bool when 'T : comparison
val (min) : 'T -> 'T -> 'T when 'T : comparison
val (max) : 'T -> 'T -> 'T when 'T : comparison
```

---

All of these routines are constrained, which means they may be used only on a subset of types that are known to support either equality (for =) or ordered comparison (for the others). It may help to think of those that implement ordered comparison as being implemented in terms of compare, which returns 0 if the arguments are equal and returns -1 and 1 for less than and greater than, respectively.

On ordinary simple types, such as integers, generic comparison works by invoking the default .NET behavior for these types, giving the natural ordering for these types. For strings, culture-neutral ordinal comparison is used, which means the local culture settings on your machine don't affect string comparison (see System.Globalization, System.Threading.Thread.CurrentThread.CurrentCulture, and String.Compare for more information about local culture settings and culture-specific string ordering). Most other .NET base types implement the System.IComparable interface, such as System.DateTime values, and generic comparison uses these implementations where necessary.

You can also use the comparison operators on most structured types. For example, you can use them on F# tuple values, where a lexicographic left-to-right comparison is used:

---

```
> ("abc", "def") < ("abc", "xyz");
val it : bool = true
> compare (10, 30) (10, 20);;
val it : int = 1
```

---

Likewise, you can use generic comparison with list and array values:

---

```
> compare [10; 30] [10; 20];;
val it : int = 1
> compare [|10; 30|] [|10; 20|];;
val it : int = 1
> compare [|10; 20|] [|10; 30|];;
val it : int = -1
```

---

## Generic Hashing

*Generic hashing* is an important partner of generic comparison. The primary primitive function used to invoke generic hashing is `hash`, again located in the `Microsoft.FSharp.Core.Operators` module. The type signature is:

---

```
val hash : 'T -> int when 'T : equality
```

---

Again, this is a constrained operation, requiring that the type support equality. Most types support some form of equality, even if it's the default reference equality of .NET.

When used with simple structural types, the function returns an integer that gives a stable hash of the input value:

---

```
> hash 100;;
val it : int = 100
> hash "abc";;
val it : int = 536991770
> hash (100, "abc");;
val it : int = 536990974
```

---

Generic hashing is implemented similarly to generic comparison. Like generic comparison, generic hashing should generally be used only with base types, such as integers, and with structural types built using records and discriminated unions.

For the most part, generic hashing and comparison are implemented efficiently—code is autogenerated for each type definition where possible fast-path comparison techniques are used. For example, the generated code uses primitive Common IL/native instructions for integer comparisons. This

means that in practice, structural comparison is typically fast when used with appropriately sized keys. However, you should consider the following before using generic comparison over complex new data types:

- When using .NET collections, consider passing the `HashIdentity.Structural` or `ComparisonIdentity.Structural` parameters to the object constructor of the collection. This helps the F# compiler optimize the performance of the hashing, equality, and comparison functions for the collection instance.
- Hashing, comparison, and equality on tuples can be slower than expected in some circumstances where the F# compiler can't optimize the hashing, equality, and comparison functions for these types. Consider replacing uses of tuples as keys by the use of a new, named key type, often using a union type with a single case, e.g. `type Key = Key of string * int`. This allows the compiler to optimize the hashing.
- Consider customizing the behavior of generic hashing, comparison, and equality for new types you define, at least when those types will be used as keys in a data structure. You can do this by implementing the `System.IComparable` interface and overriding the `System.Object.Equals` method, covered in Chapter 8. You can customize generic hashing for new types by either overriding the `GetHashCode` method or implementing the `Microsoft.FSharp.Core.IStructuralHash` interface, also covered in Chapter 8.
- Both ordered comparison and equality (in combination with hashing) can be used to build interesting indexed data structures. Collections built using these techniques are efficient over small keys. Performance issues may arise, however, if they're used repeatedly over large structured keys. In this case, using custom comparison may be appropriate.

## Generic Pretty-Printing

Some useful generic functions do generic formatting of values. The simplest ways to access this functionality is to use the `%A` specifiers in `printf` format strings. Here is an example:

---

```
> sprintf "result = %A" ([1], [true]);;
val it : string = "result = ([1], [true])"
```

---

This code uses .NET and F# reflection to walk the structure of values to build a formatted representation of the value. You format structural types such as lists and tuples using the syntax of F# source code. Unrecognized values are formatted by calling the .NET `ToString()` method for these values. F# and .NET reflection are discussed in more depth toward the end of Chapter 17.

## Generic Boxing and Unboxing

Two useful generic functions convert any F# data to and from the universal type `System.Object` (the F# type `obj`):

---

```
val box : 'T -> obj
val unbox : obj -> 'T
```

---

Here are some simple examples of these functions in action:

---

```
> box 1;;
val it : obj = 1
> box "abc";;
val it : obj = "abc"
> let stringObj = box "abc";;
val stringObj : obj = "abc"
> (unbox<string> stringObj);;
val it : string = "abc"
> (unbox stringObj : string);;
val it : string = "abc"
```

---

Note that using `unbox` generally requires you to specify the target type, given either as an explicit type parameter `unbox<string>` or as a type constraint (`unbox stringObj : string`)—these forms are equivalent. A runtime check is performed on unboxing to ensure that the object can be safely converted to the target type. Values of type `obj` carry dynamic type information, and attempting to unbox a value to an incompatible type raises an error:

---

```
> (unbox stringObj : int);;
System.InvalidCastException: Specified cast is not valid.
   at <StartupCode$FSI_0046>.$FSI_0046.main@()
Stopped due to error
```

---

Boxing is important partly because many early .NET libraries provide operations through functions that accept arguments of type `obj`. You see an example in the next section. Furthermore, some .NET APIs are dynamically typed, and almost all parameters are of type `obj`. This was common before generics were added in v2.0 of the .NET framework.

## Generic Binary Serialization via the .NET Libraries

The .NET libraries provide an implementation of generic binary serialization that is useful as a quick and easy way of saving computed values to disk and sending values over the network. Let's use this as an example to see how you can define building-block generic operations using functionality in the .NET libraries combined with `box` and `unbox`. You first define functions with the following signatures:

---

```
val writeValue : outputStream:System.IO.Stream -> x:'T -> unit
val readValue : inputStream:Stream -> 'a
```

---

The function `writeValue` takes an arbitrary value and writes a binary representation of its underlying object graph to the given I/O stream. The function `readValue` reverses this process, in much the same way



that `unbox` reverses the process performed by `box`. Here are the implementations of the functions in terms of the .NET binary serializer located in the namespace `System.Runtime.Serialization.Formatters.Binary`:

```
open System.IO
open System.Runtime.Serialization.Formatters.Binary

let writeValue outputStream (x : 'T) =
    let formatter = new BinaryFormatter()
    formatter.Serialize(outputStream, box x)

let readValue inputStream =
    let formatter = new BinaryFormatter()
    let res = formatter.Deserialize(inputStream)
    unbox res
```

Note that `box` and `unbox` are used in the implementation, because the `Serialize` and `Deserialize` functions accept and return a value of type `obj`. Here is an example of how to use the functions to write a value of type `Microsoft.FSharp.Collections.Map<string, string>` to a `FileStream` and read it back in again:

```
open System.IO
let addresses = Map.ofList [
    "Jeff", "123 Main Street, Redmond, WA 98052"
    "Fred", "987 Pine Road, Phila., PA 19116"
    "Mary", "PO Box 112233, Palo Alto, CA 94301"]

let fsOut = new FileStream("Data.dat", FileMode.Create)
writeValue fsOut addresses
fsOut.Close()
let fsIn = new FileStream("Data.dat", FileMode.Open)
let res : Map<string, string> = readValue fsIn
fsIn.Close()
```

The final result of this code when executed interactively is:

---

```
> res;;
val it : Map<string,string> =
    map
    [
        ("Fred", "987 Pine Road, Phila., PA 19116");
        ("Jeff", "123 Main Street, Redmond, WA 98052");
        ("Mary", "PO Box 112233, Palo Alto, CA 94301")]
```

---

Note that values of type `Map<string, string>` are printed interactively as sequences of key/value pairs. Also, a type annotation is required when reading the data back in using `readValue`, and a runtime type error results if the types of the objects reconstructed from the binary data don't match this type annotation.

The .NET Framework provides several other generic serializers that differ in output format and operational characteristics. The most important of these are based around the notion of `DataContract` serialization:

- `System.Runtime.Serialization.Json.DataContractJsonSerializer`: Used for serializing public data objects into the popular JavaScript Object Notation (JSON) format, using formats that aren't specifically tied to particular .NET types but that are, rather, compatible with a range of types
- `System.Runtime.Serialization.DataContractSerializer`: Used for serializing public data objects into XML, using formats that aren't specifically tied to particular .NET types but that are, rather, compatible with a range of types
- `System.Runtime.Serialization.NetDataContractSerializer`: Used for serializing arbitrary object graphs, including private data and closures, into XML using the same idioms as the other `DataContract` serializers

In addition, you can use some older serializers with F#. For example, `System.Runtime.Serialization.XmlSerializer` is used for serializing public data into XML. This serializer is now used less frequently; you should generally use `NetDataContractSerializer` instead. You can also write your own generic serializer, for example using the techniques described in Chapter 8.

## Making Things Generic

The following sections discuss how to make existing code more generic (that is, reusable) and how to systematically represent the abstract parameters of generic algorithms.

### Generic Algorithms through Explicit Arguments

A common pattern in F# programming is to accept function parameters in order to make an algorithm abstract and reusable. A simple sample is the following generic implementation of Euclid's algorithm for finding the highest common factor (HCF) of two numbers:

```
let rec hcf a b =
    if a = 0 then b
    elif a < b then hcf a (b - a)
    else hcf (a - b) b
```

The type of this function is:

---

```
val hcf : a:int -> b:int -> int
```

---

For example:

---

```
> hcf 18 12;;
val it : int = 6
> hcf 33 24;;
val it : int = 3
```

---

This algorithm isn't generic, however, because as written, it works only over integers. In particular, although the operator `(-)` is by default overloaded in F#, each use of the operator must be associated with at

most one type decided at compile time. This restriction is discussed in more detail in the section “Understanding Generic Overloaded Operators.” In addition, the constant 0 is an integer and isn’t overloaded.

Despite this, this algorithm can be easily generalized to work over any type. To achieve this, you must provide an explicit zero, a subtraction function, and an ordering. Here’s one way:

```
let hcfGeneric (zero, sub, lessThan) =
  let rec hcf a b =
    if a = zero then b
    elif lessThan a b then hcf a (sub b a)
    else hcf (sub a b) b
  hcf
```

The inferred, generic type of this function is as follows:

---

```
val hcfGeneric :
  zero:'a * sub:( 'a -> 'a -> 'a) * lessThan:( 'a -> 'a -> bool) ->
  ( 'a -> 'a -> 'a) when 'a : equality
```

---

The numeric type being manipulated has type 'a in the inferred type, and the result is a computed function. This approach uses techniques for computing functions similar to those discussed in Chapter 3. Here are some examples of using this generic function:

```
let hcfInt = hcfGeneric (0, (-), (<))
let hcfInt64 = hcfGeneric (0L, (-), (<))
let hcfBigInt = hcfGeneric (0I, (-), (<))
```

Note that when you instantiate the generic function for these cases, you’re drawing on particular instances of the default overloaded operator (-). You can check that the code is executing correctly as follows:

---

```
> hcfInt 18 12;;
val it : int = 6
> hcfBigInt 1810287116162232383039576I 1239028178293092830480239032I;;
val it : System.Numerics.BigInteger = 33224
```

---

## Generic Algorithms through Function Parameters

The generic implementation from the previous section took three related parameters for zero, comparison, and subtraction. It’s common practice to package related operations together. One way to do this is to use a concrete record type containing function values:

```
type Numeric<'T> =
  {Zero : 'T;
  Subtract : ('T -> 'T -> 'T);
  LessThan : ('T -> 'T -> bool);}
```

```

let intOps = {Zero = 0; Subtract = (-); LessThan = (<)}
let bigintOps = {Zero = 0I; Subtract = (-); LessThan = (<)}
let int64Ops = {Zero = 0L; Subtract = (-); LessThan = (<)}

let hcfGeneric (ops : Numeric<'T>) =
    let rec hcf a b =
        if a = ops.Zero then b
        elif ops.LessThan a b then hcf a (ops.Subtract b a)
        else hcf (ops.Subtract a b) b
    hcf

let hcfInt = hcfGeneric intOps
let hcfBigInt = hcfGeneric bigintOps

```

The inferred types are as follows and the `hcfGeneric` type is now simpler:

---

```

val hcfGeneric : ops:Numeric<'T> -> ('T -> 'T -> 'T) when 'T : equality
val hcfInt : (int -> int -> int)
val hcfBigInt :
    (System.Numerics.BigInteger -> System.Numerics.BigInteger -> System.Numerics.BigInteger)

```

---

To double-check that everything works as before:

---

```

> hcfInt 18 12;;
val it : int = 6
> hcfBigInt 1810287116162232383039576I 1239028178293092830480239032I;;
val it : System.Numerics.BigInteger = 33224

```

---

Record types such as `Numeric<'T>`, often called *dictionaries of operations*, are similar to vtables from object-oriented programming and the compiled form of type classes from Haskell. As you've seen, dictionaries such as these can be represented in different ways according to your tastes, using tuples or records. For larger frameworks, a carefully constructed classification of *object interface types* is often used in place of records. Here is an interface type definition that plays the same role as the record in the previous example:

```

type INumeric<'T> =
    abstract Zero : 'T
    abstract Subtract : 'T * 'T -> 'T
    abstract LessThan : 'T * 'T -> bool

```

You can implement interface types with object expressions similarly to record values:

```

let intOps =
    {new INumeric<int> with
        member ops.Zero = 0
        member ops.Subtract(x, y) = x - y
    }

```

```
member ops.LessThan(x, y) = x < y}
```

---

```
val intOps : INumeric<int>
```

---

The code for Euclid’s algorithm using interface types is essentially the same as for the code based on record types:

```
let hcfGeneric (ops : INumeric<'T>) =
    let rec hcf a b =
        if a = ops.Zero then b
        elif ops.LessThan(a, b) then hcf a (ops.Subtract(b, a))
        else hcf (ops.Subtract(a, b)) b
    hcf
```

---

## GENERIC ALGORITHMS AND FUNCTION PARAMETERS

---

One of the remarkable features of functional programming with F# is that generic programming is practical even when the types involved aren’t explicitly related. For example, the previous generic algorithm shows how you can write reusable code without resorting to relating the types involved through an inheritance hierarchy: the generic algorithm works over any type if an appropriate set of operations is provided to manipulate values of that type. This is a form of *explicit factoring by functions*. Object-oriented programming typically uses *implicit factoring by hierarchy*, because the library designer decides the relationships that hold among various types, and these are fixed in stone.

Type inference in F# makes explicit factoring by functions convenient. Given the simplicity and flexibility of this approach, it’s a useful way to write applications and to prototype frameworks. Factoring by hierarchy still plays a role in F# programming, however. For example, all F# values can be implicitly converted to and from the type `System.Object`, something that is extremely useful when you’re interoperating with many libraries. It would obviously be inconvenient to have to pass around functions to marshal (box/unbox) types to `System.Object` and back. Similarly, many F# values can be implicitly converted to the `IDisposable` interface. Hierarchical factoring requires careful design choices; in general, we recommend that you use explicit factoring first, moving toward implicit factoring only when an algorithmic pattern is truly universal and repeats itself many times, as is the case with the `IDisposable` idiom. The .NET and F# libraries contain definitions of many of the implicit factors you should use in practice, such as `IDisposable` and `IEnumerable`.

Some functional languages, such as Haskell, allow you to implicitly pass dictionaries of operations through an extension to type inference known as type classes. At the time of writing, this isn’t supported by F#, but the designers of F# have stated that they expect a future version of the language to support this. Either way, explicitly passing dictionaries of operations is common in all functional programming and is an important technique to master.

---

## Generic Algorithms through Inlining

An additional way to make code generic is to mark a function as `inline`. You can use this technique for code that uses F# operators, such as `float`, `int`, `+`, `-`, `*`, `/`, and other arithmetic operations. As we’ll discuss in the section “Understanding Generic Overloaded Operators,” each use of these operators is normally statically resolved. For example, consider this code:

```
let convertToFloat x = float x
```

In the F# type system, the type of the float function is `'T -> float` (requires member `op_Explicit`). This means the type `'T` must support an explicit conversion from `'T` to `float`. Thus, you can use it with integers, singles, doubles, decimals, and so on, but you can't use it with any old type. The `'T` is constrained.

As mentioned earlier, F# operators such as `float` are statically resolved. This means each use of `float` is associated with one statically inferred type. The same applies to other operators such as `+`, `*`, and so on. These operators also generally default to working over integers. For example, this shows `float` being used with three different statically resolved types:

```
float 3.0 + float 1 + float 3L
```

To make code such as this generic, you can use `inline`. For example, consider:

```
let inline convertToFloatAndAdd x y = float x + float y
```

`convertToFloatAndAdd` can be used with an integer and a float, or a decimal and an integer, or two decimals. You can use `inline` to write code and algorithms that are implicitly generic over arithmetic type while still maintaining type safety. This gives you generic, type-safe code while ensuring static resolution of basic numeric operations, making it easy to reason about the efficiency of your code.

You can also apply this technique to the earlier HCF algorithm:

```
let hcfGeneric (ops : INumeric<'T>) =
    let rec hcf a b =
        if a = ops.Zero then b
        elif ops.LessThan(a, b) then hcf a (ops.Subtract(b, a))
        else hcf (ops.Subtract(a, b)) b
    hcf
```

The type of this function is:

---

```
val inline hcf :
  a: ^a -> b: ^a -> ^a
  when ^a : (static member get_Zero : -> ^a) and ^a : comparison and
    ^a : (static member ( - ) : ^a * ^a -> ^a)
```

---

For example:

---

```
> hcf 18 12;;
val it : int = 6
> hcf 18I 12I;;
val it : System.Numerics.BigInteger = 6
```

---

The algorithm is now generic. You should use this technique sparingly, but it can be extremely powerful. Note the use of the F# library primitive `GenericZero` to get a zero value for an arbitrary type supporting a `Zero` static property.

One variation on this technique provides a simple wrapper that delegates to a non-inlined generic routine. For example, the following code delegates to the non-inlined routine `hcfGeneric`, defined earlier in this section:

```

let inline hcf a b =
    hcfGeneric
        {new INumeric<'T> with
            member ops.Zero = LanguagePrimitives.GenericZero<'T>
            member ops.Subtract(x, y) = x - y
            member ops.LessThan(x, y) = x < y}
    a b

```

This gives you a generic function `hcfGeneric` that can be used with any explicit set of arithmetic operations, and a generic routine `hcf` that can be used with any type that supports an implicit set of arithmetic operations.

## More on Different Kinds of Types

For the most part, programming in F# involves using types in a simple way: each type has some values, and types are related by using explicit functions to map from one type to another. In reality, however, types in F# are more sophisticated than this statement implies. First, F# types are really .NET types, and .NET makes some distinctions among different kinds of types that are occasionally important, such as between value types and reference types.

Furthermore, .NET and F# support hierarchical relationships between types through *subtyping*. The following sections first cover .NET types from the F# perspective and then cover subtyping.

## Reference Types and Value Types

The .NET documentation and other .NET languages often describe types as either *reference types* or *value types*. You can use `System.String` and `System.DateTime` as a typical example of each. First note that both of these types are immutable. That is, given a value of type `System.String`, you can't modify the contents of the string; the same is true for `System.DateTime`. This is by far the most important fact you need to know about these types: for immutable types the reference/value type distinction is relatively unimportant. It's still useful, however, to know the following:

- *Representation*: Values of type `System.String` are single pointers into the garbage-collected heap where the actual data for the string reside. Two `System.String` values may point to the same data. In contrast, values of type `System.DateTime` are somewhat larger blobs of integer data (64-bits of data, in this case), and no data live on the garbage-collected heap. The full data for the value are copied as needed.
- *Boxing*: All .NET types can be marshaled to and from the .NET type `System.Object` (the F# type `obj`) by using F# functions such as `box` and `unbox`. All reference types are trivially marshaled to this type without any change of representation or identity, so for reference types, `box` is a no-op. Boxing a value type involves a heap allocation, resulting in a new object. Often this object is immediately discarded after the operation on the `obj` type has been performed.

If a value can be mutated, then the distinction between value types and reference types is more serious. Fortunately, essentially all mutable values in the .NET libraries are reference types, which means mutation actually mutates the heap-allocated data referred to by the reference.

## Other Flavors of .NET Types

The .NET type system makes some additional distinctions among types that are occasionally significant for F# programming:

- *Delegate types*: Delegate types, such as `System.Windows.Forms.MouseEventHandler`, are a form of named function type supported by all .NET languages. They tend not to be as convenient to use as F# function types, because they don't support compositional operations such as pipelining and forward composition, but .NET APIs use delegates extensively. To create a delegate value, you name the delegate type and pass it a function value that accepts the same arguments expected by the delegate type, such as `MouseEventHandler(fun sender args -> printf "click!\n")`.
- *Attribute types*: Types derived from the `System.Attribute` class are used to add metadata to source-code declarations and typically end in the suffix `Attribute`. You can access these attributes via .NET and F# reflection. You can add attributes to F# declarations using the `[<...>]` syntax. For example, `System.ObsoleteAttribute` marks a function as obsolete, and the F# compiler produces a warning if the function is used. Attribute names such as this one, when used inside the `[<...>]` syntax, can omit the `...Attribute` suffix, which is then automatically inserted by the F# compiler.
- *Exception types*: Types derived from the `System.Exception` class are used to represent raised exceptions. Chapter 4 discussed exceptions in detail.
- *Enum types*: .NET enum types are simple integer-like value types associated with a particular name. They're typically used for specifying flags to APIs; for example, `FileMode` in the `System.IO` namespace is an enum type with values such as `FileMode.Open` and `FileMode.Create`. .NET enum types are easy to use from F# and can be combined using bitwise AND, OR, and XOR operations using the `&&&`, `|||`, and `^^^` operators. Most commonly, the `|||` operator is used to combine multiple flags. On occasion, you may have to mask an attribute value using `&&&` and compare the result to `enum 0`. You see how to define .NET-compatible enum types in F# at the end of Chapter 6.

## Understanding Subtyping

Simple types are related in simple ways. For example, values of the type `int` are distinct from values of the type `float`, and values of one record type are distinct from values of another. This approach to types is powerful and often sufficient, partly because type inference and function values make it easy to write generic code, although .NET and F# also support hierarchical relationships between types through *subtyping*. Subtyping is a key concept of object-oriented programming and is discussed in more detail in Chapter 6. In addition, you can use subtyping in conjunction with pure functional programming, because it offers one technique to make algorithms generic over a restricted family of types.

The following sections explain how these constructs appear to the F# programmer and the role they play in F# programming. Subtyping in F# is the same as that used by the .NET Framework, so if you're familiar with another .NET language, you already know how things work.



## Casting Up Statically

You can explore how subtyping works by using F# Interactive. First, let's look at how some of the F# types you've already seen relate to the type `obj`:

---

```
> let xobj = (1 :> obj);;
val xobj : obj = 1
> let sobj = ("abc" :> obj);;
val sobj : obj = "abc"
```

---

This example shows the subtyping relationship through the use of the built-in coercion (or *upcast*) operator, which is `:>`. This operator converts a value to any of its supertypes in precisely the same way as the `box` function.

The previous code indicates the subtyping between ordinary types and the type `obj`. Subtyping occurs between other kinds of types as well (Chapters 3 and 6 discuss the various kinds of type definitions, such as records, discriminated unions, classes, and interfaces):

- All types are subtypes of `System.Object` (called `obj` in F#).
- Record and discriminated union types are subtypes of the interface types they implement.
- Interface types are subtypes of the other interfaces they extend.
- Class types are subtypes of both the interfaces they implement and the classes they extend.
- Array types are subtypes of the .NET type `System.Array`.
- Value types (types such as `int32` that are abbreviations of .NET value types) are subtypes of the .NET type `System.ValueType`. Likewise, .NET enumeration types are subtypes of `System.Enum`.

## Casting Down Dynamically

Values that may have subtypes carry a *runtime type*, and you can use runtime-type tests to query the type of an object and convert it to one of the subtypes. You can do this in three main ways: the `unbox` operation, downcasts, and pattern type tests. We've already explained the `unbox` function. As with most object-oriented languages, the upcasts performed through subtyping are reversible through the use of downcasts—in other words, by using the `?:>` operator. Consider these examples:

---

```
> let boxedObject = box "abc";;
val boxedObject : obj
> let downcastString = (boxedObject :?> string);;
val downcastString : string = "abc"
```

---

Downcasts are checked at runtime and all values of the `obj` type are implicitly annotated with the runtime type of the value. The operator `?:>` raises an exception if the object isn't of a suitable type:

---

```
> let xobj = box 1;;
val xobj : obj = 1
> let x = (xobj :?> string);;
System.InvalidCastException: Unable to cast object of type 'System.Int32' to type 'System.String'.
at <StartupCode$FSI_0037>.$FSI_0037.main@()
```

---

## Performing Type Tests via Pattern Matching

A more convenient way of performing dynamic type tests uses *type-test patterns*—in particular the `:?>` pattern construct, which you encountered in Chapter 4 in the context of catching various .NET exception types. This example uses a pattern-type test to query the dynamic type of a value of type `obj`:

```
let checkObject (x : obj) =
    match x with
    | :? string -> printfn "The object is a string"
    | :? int -> printfn "The object is an integer"
    | _ -> printfn "The input is something else"
```

---

```
> checkObject (box "abc");;
The object is a string
```

---

Such a pattern may also bind the matched value at its more specific type:

```
let reportObject (x : obj) =
    match x with
    | :? string as s -> printfn "The input is the string '%s'" s
    | :? int as d -> printfn "The input is the integer '%d'" d
    | _ -> printfn "the input is something else"
```

---

```
> reportObject (box 17);;
The input is the integer '17'
```

---

## Knowing When Upcasts Are Applied Automatically

Like most object-oriented languages, F# automatically applies upcasts whenever a function or method is called or wherever a value is used. If a parameter to an F# function has a named type, then the function implicitly accepts parameters that are any subtype, assuming that type supports subtyping. This is particularly common when working with .NET libraries that use subtyping heavily. For example:

---

```
> open System.Windows.Forms;;
> let setTextOfControl (c : Control) (s : string) = c.Text <- s;;
```

---

```

val setTextOfControl : c:Control -> s:string -> unit
> let form = new Form();;
val form : Form = System.Windows.Forms.Form, Text:
> let textBox = new TextBox();;
val textBox : TextBox = System.Windows.Forms.TextBox, Text:
> setTextOfControl form "Form Text";;
> setTextOfControl textBox "Text Box Text";;

```

---

Here, the function `setTextOfControl` is used on two different subtypes of `Control`. When functions have parameters that accept named types such as `Control`, you don't need to supply an upcast explicitly.

`F#` doesn't apply upcasts in all the situations where other object-oriented languages do, however. In practice, this means you sometimes have to add explicit upcasts to your code to throw away information. For example, if each branch of an `if ... then ... else ...` construct returns different types, then you need to upcast the results of one or both of the branches. This is shown by the type error given for the following code, which returns `Console.In` (a `TextReader`) from one branch and the results of `File.OpenText` (a `StreamReader`) from the other branch:

```

open System
open System.IO

let textReader =
    if DateTime.Today.DayOfWeek = DayOfWeek.Monday
    then Console.In
    else File.OpenText("input.txt")

```

The error reported is as follows:

---

```

error FS0001: This expression was expected to have type
    TextReader
but here has type
    StreamReader

```

---

`StreamReader` is a subtype of `TextReader`, so the code can be corrected by throwing away the information that the returned type is a `StreamReader`:

```

open System
open System.IO

let textReader =
    if DateTime.Today.DayOfWeek = DayOfWeek.Monday
    then Console.In
    else (File.OpenText("input.txt") :> TextReader)

```

Upcasts are applied automatically in the following situations:

- When passing arguments to functions and all members associated with .NET and F# objects and types. This applies when parameters have named types, such as `TextReader`, rather than generic types.
- When calling functions with flexible parameter types (see in the following section), such as `#TextReader`.
- When assigning into fields and properties.
- When accessing members using dot notation. For example, given a value of type `StreamReader`, all the members associated with `TextReader` can also be accessed without needing to apply an upcast.

Note particularly that upcasts aren't applied automatically for the result of a function. For example, an upcast is needed here, to coerce a `StreamReader` to a `TextReader`, despite the presence of an explicit type annotation for the return type:

```
let getTextReader () : TextReader = (File.OpenText("input.txt") :> TextReader)
```

## Flexible Types

F# also has the notion of a *flexible type constraint*, which is shorthand for a generic function and a constraint on the type variable. You could equally write this:

---

```
> open System.Windows.Forms;;
> let setTextOfControl (c : 'T when 'T :> Control) (s : string) = c.Text <- s;;
val setTextOfControl: c:#Control -> s:string -> unit
```

---

Automatic generalization lifts the constraints implicit in types of the form `#type` to the nearest enclosing function or member definition. Flexible type constraints sometimes occur when you're working with sequence values. For example, consider this function from the F# library:

---

```
module Seq =
    ...
    val concat : seq<#seq<'T>> -> seq<'T>
    ...
```

---

When implicit flexibility of arguments is taken into account, the signature of `concat` means that `Seq.concat` accepts a list of lists, or a list of arrays, or an array of lists, and so forth. For example:

```
Seq.concat [[1;2;3]; [4;5;6]]
Seq.concat [[1; 2; 3]]; [[4; 5; 6]] ]
```

## Troubleshooting Type-Inference Problems

The following sections cover some of the techniques you can use to understand the type-inference process and to debug problems when inferred types aren't as expected.

## Using a Visual Editing Environment

The best and most important technique to debug and understand type inference is to use a visual editing environment for F#. For example, Visual Studio performs interactive type-checking as you're writing code. Such tools display errors interactively and show inferred types as you move the mouse pointer over identifiers.

## Using Type Annotations

Type inference in F# works through a process of type-constraint *propagation*. As a programmer, you can add further type constraints to your code in several ways. For example, you can do the following:

- Add a rigid type constraint using the `:` notation, such as `let t : float = 5.0`.
- Add a type constraint to an argument, such as `let setTextOfControl (c : Control) (s : string) = c.Text <- s`.
- Apply a function that accepts only a particular type of argument, such as `let f x = String.length x`. Here, the use of `String.length` generates a constraint on the type of `x`.

Adding type annotations to and removing them from your code is the standard technique to troubleshoot type-inference problems. For example, the following code doesn't type-check:

---

```
> let getLengths inp = inp |> Seq.map (fun y -> y.Length) ;;
```

```
error FS0072: Lookup on object of indeterminate type based on information prior to this program point. A type annotation may be needed prior to this program point to constrain the type of the object. This may allow the lookup to be resolved.
```

---

You can easily solve this problem by adding a type annotation, such as to `y`:

```
let getLengths inp =
    inp |> Seq.map (fun (y : string) -> y.Length)
```

You can also use type annotations to discover why code isn't as generic as you think it should be. For example, the following code has a mistake, and the F# type checker says the code is less generic than expected:

```
let printSecondElements (inp : seq<'T * int>) =
    inp
    |> Seq.iter (fun (x, y) -> printfn "y = %d" x)
```

---

```
> ... enter the code above ...
```

```
warning FS0064: This construct causes code to be less generic than indicated by the type annotations. The type variable 'T' has been constrained to be type 'int'.
```

---

The mistake here is that you're printing the variable `x` instead of `y`, but it's not always so easy to spot what has caused this kind of problem. One way to track down this problem is to temporarily change the generic type parameter to some arbitrary, unrelated type. After all, if code is generic, then you should be

able to use *any* type; and by changing the type variable to an unrelated type, you can track down where the inconsistency first arises. For example, let's change 'T to the type PingPong:

```
type PingPong = Ping | Pong

let printSecondElements (inp : seq<PingPong * int>) =
    inp
    |> Seq.iter (fun (x,y) -> printfn "y = %d" x)
```

You now get a different and in many ways more informative error message, localized to the first place that the value x marked with type PingPong is used in an unexpected way:

---

```
> ... enter the code above ...
```

```
error FS0001: The type 'PingPong' is not compatible with any of the types byte,int16,int32,int64,sbyte,uint16,uint32,uint64,nativeint,unativeint, arising from the use of a printf-style format string
```

---

## Understanding the Value Restriction

F# sometimes requires a little help before a definition is automatically generalized. In particular, only function definitions and simple immutable data expressions are automatically generalized; this is called the *value restriction*. For example, the following definition doesn't result in a generic type and gives an error:

---

```
> let empties = Array.create 100 [];
```

```
error FS0030: Value restriction. The value 'empties' has been inferred to have generic type
    val empties : '_a list []
```

*Either define 'empties' as a simple data term, make it a function with explicit arguments or, if you do not intend for it to be generic, add a type annotation.*

---

The code attempts to create an array of empty lists. The error message indicates that type inference has given empties the type '\_a list []'. The underscore (\_) indicates that the type variable 'a is *ungeneralized*, meaning this code isn't fully generic. It would make no sense to give empties the truly generic type 'a list [], because this would imply that you've created an array of lists somehow suitable for use with any type 'a. In reality, any particular array should have one specific type, such as int list [] or string list [], but not both. (If it were usable with both types, then you could store an integer list in the array and fetch it out as a string list!)

The value restriction ensures that declarations don't result in this kind of confusion; automatic generalization isn't applied to declarations unless they're functions or simple, immutable data constructs. One way to think of this is that you can create concrete objects only after the type-inference problem is sufficiently constrained so that every concrete object created at the top level of your program has a ground type—a type that doesn't contain any ungeneralized type variables.

The value restriction doesn't apply to simple immutable data constants or function definitions. For example, the following declarations are all automatically generalized, giving the generic types shown:

```
let emptyList = []
let initialLists = ([], [2])
```

```
let listOfEmptyLists = [[]; []]
let makeArray () = Array.create 100 []
```

---

```
val emptyList : 'a list
val initialLists : 'a list * int list
val listOfEmptyLists : 'a list list
val makeArray : unit -> 'a list []
```

---

## Working Around the Value Restriction

The value restriction crops up with mild regularity in F# coding—particularly when you’re using F# Interactive, where the scope of type inference is at the granularity of each entry sent to the tool rather than an entire file, and hence, fewer constraints are placed on these code fragments. You can work around the value restriction in several ways, depending on what you’re trying to do.

### Technique 1: Constrain Values to Be Nongeneric

The first technique applies when you make a definition such as `empties`, shown earlier, but you meant to create one value. Recall that this definition was problematic because it’s not clear what type of array is being created:

```
let empties = Array.create 100 []
```

If you meant to create one value with a specific type, then use an explicit type annotation:

```
let empties : int list [] = Array.create 100 []
```

The value is then not generic, and the value restriction doesn’t apply.

### Technique 2: Ensure Generic Functions Have Explicit Arguments

The next technique applies when you’re defining generic functions. In this case, make sure you define them with explicit arguments. For example, look at the following definition of a function value:

```
let mapFirst = List.map fst
```

You may expect this to be a generic function with type `('a * 'b) list -> 'a list`. This isn’t what happens. Type variables are automatically generalized at true syntactic function definitions—that is, function definitions with *explicit* arguments. The function `mapFirst` has *implicit* arguments. Fortunately, it’s easy to work around this by making the arguments explicit (or in academic terms, performing  $\eta$  [eta] abstraction):

```
let mapFirst inp = List.map fst inp
```

This function now has the following type:

---

```
val mapFirst : inp:(('a * 'b) list) -> 'a list
```

---

When there is only one argument, our favorite way of writing the extra arguments is as follows:

```
let mapFirst inp = inp |> List.map (fun (x, y) -> x)
```

The same problem arises when you try to define functions by composition. For example:

```
let printFstElements = List.map fst >> List.iter (printf "res = %d")
```

The arguments here are implicit, which causes problems. This definition isn't automatically generalized because this isn't a syntactic function. Again, make the arguments explicit:

```
let printFstElements inp = inp |> List.map fst |> List.iter (printf "res = %d")
```

### Technique 3: Add Dummy Arguments to Generic Functions When Necessary

Look at this definition again:

```
let empties = Array.create 100 []
```

It's possible that you really did intend to define a function that generates arrays of different types on demand. In this case, add a dummy argument:

```
let empties () = Array.create 100 []
let intEmpties : int list [] = empties()
let stringEmpties : string list [] = empties()
```

The dummy argument ensures that `empties` is a function with generic arguments and that it can be automatically generalized.

### Technique 4: Add Explicit Type Arguments When Necessary

You can use one final technique to make a value generic. This one is rarely used, but it is very handy when it's required. It's normally used when you're defining values that are generic but that are neither functions nor simple data expressions. For example, let's define a sequence of 100 empty lists:

```
let emptyLists = Seq.init 100 (fun _ -> [])
```

The expression on the right isn't a function or simple data expression (it's a function application), so the value restriction applies. One solution is to add an extra dummy argument, as in the previous section. If you're designing a library, however, this can seem very artificial. Instead, you can use the following declaration form to make `emptyLists` generic:

```
let emptyLists<'T> : seq<'T list> = Seq.init 100 (fun _ -> [])
```

You can now use `emptyLists` as a *type function* to generate values of different types. For example:

---

```
> Seq.length emptyLists;;
val it : int = 100
> emptyLists<int>;;
```



```

val it : seq<int list> = seq [[]; []; []; []; ...]
> emptyLists<string>;;
val it : seq<string list> = seq [[]; []; []; []; ...]

```

---

Some values and functions in the F# library are defined in this way, including `typeof<_>`, `Seq.empty`, and `Set.empty`. Chapter 17 covers `typeof`.

## Understanding Generic Overloaded Operators

There is one further important way in which code doesn't automatically become generic in F#: when you use overloaded operators such as `+`, `-`, `*`, and `/`, or overloaded conversion functions such as `float` and `int64`. For example, the following is *not* a generic function:

```
let twice x = (x + x)
```

In the absence of further information, the type of this function is as follows:

```
val twice : x:int -> int
```

---

This is because the overloaded operator `+` defaults to operating on integers. If you add type annotations or further type constraints, you can force the function to operate on any type supporting the overloaded `+` operator:

```
let twiceFloat (x : float) = x + x
```

```
val twiceFloat : x:float -> float
```

---

The information that resolves a use of an overloaded operator can come after the use of the operator:

```

let threeTimes x = (x + x + x)
let sixTimesInt64 (x:int64) = threeTimes x + threeTimes x

```

```

val threeTimes : x:int64 -> int64
val sixTimesInt64 : x:int64 -> int64

```

---

Note how the constraint in the definition of `sixTimesInt64` is the only mention of `int64` and affects the type of `threeTimes`. The technical explanation is that overloaded operators such as `+` give rise to *floating* constraints, which can be resolved later in the type-inference scope.

## Summary

F# is a typed language, and F# programmers often use types in sophisticated ways. In this chapter, you learned about the foundations of types, focusing on how types are used in functional programming and with generics and subtyping in particular. The next chapter covers the related topics of object-oriented and modular programming in F#.

## CHAPTER 6



# Programming with Objects

Chapters 2 through 5 dealt with the basic constructs of F# functional and imperative programming, and by now we trust you're familiar with the foundational concepts and techniques of practical, small-scale F# programming. This chapter covers language constructs related to *object programming*.

Programming in F# tends to be less “object-oriented” than in other languages, since functional programming with values, functions, lists, tuples and other shaped data is enough to solve many programming problems. Objects are used as a means to an end rather than as the dominant paradigm.

The first part of this chapter focuses on object programming with concrete types. We assume some familiarity with the basic concepts of object-oriented programming, although you may notice that our discussion of objects deliberately deemphasizes techniques such as implementation inheritance. You're then introduced to the notion of object interface types and some simple techniques to implement them. The chapter covers more advanced techniques to implement objects using function parameters, delegation, and implementation inheritance. Finally, it covers the related topics of modules (which are simple containers of functions and values) and extensions (in other words, how to add ad hoc dot-notation to existing modules and types). Chapter 7 covers the topic of encapsulation.

This chapter deemphasizes the use of .NET terminology for object types. However, all F# types are ultimately compiled as .NET types.

## Getting Started with Objects and Members

One of the most important activities of object programming is defining concrete types equipped with dot-notation. A concrete type has *fixed* behavior: that is, it uses the same member implementations for each concrete value of the type.

You've already met many important concrete types, such as integers, lists, strings, and records (introduced in Chapter 3). It's easy to add object members to concrete types. Listing 6-1 shows an example.

*Listing 6-1. A Vector2D Record Type with Object Members*

```
/// Two-dimensional vectors
type Vector2D =
    { DX : float; DY : float }

    /// Get the length of the vector
    member v.Length = sqrt(v.DX * v.DX + v.DY * v.DY)

    /// Get a vector scaled by the given factor
    member v.Scale(k) = { DX = k * v.DX; DY = k * v.DY }
```

```

/// Return a vector shifted by the given delta in the X coordinate
member v.ShiftX(x) = { v with DX = v.DX + x }

/// Return a vector shifted by the given delta in the Y coordinate
member v.ShiftY(y) = { v with DY = v.DY + y }

/// Return a vector shifted by the given distance in both coordinates
member v.ShiftXY(x,y) = { DX = v.DX + x; DY = v.DY + y }

/// Get the zero vector
static member Zero = { DX = 0.0; DY = 0.0 }

/// Return a constant vector along the X axis
static member ConstX(dx) = { DX = dx; DY = 0.0 }

/// Return a constant vector along the Y axis
static member ConstY(dy) = { DX = 0.0; DY = dy }

```

You can use the properties and methods of this type as follows:

---

```

> let v = { DX = 3.0; DY=4.0 };;
val v : Vector2D = {DX = 3.0; DY = 4.0;}
> v.Length;;
val it : float = 5.0
> v.Scale(2.0).Length;;
val it : float = 10.0
> Vector2D.ConstX(3.0);;
val it : Vector2D = {DX = 3.0; DY = 0.0}

```

---

As usual, it's useful to look at inferred types to understand a type definition. Here are the inferred types for the Vector2D type definition of Listing 6-1.

---

```

type Vector2D =
  {DX: float;
   DY: float;}
  with
    member Scale : k:float -> Vector2D
    member ShiftX : x:float -> Vector2D
    member ShiftXY : x:float * y:float -> Vector2D
    member ShiftY : y:float -> Vector2D
    member Length : float
    static member ConstX : dx:float -> Vector2D
    static member ConstY : dy:float -> Vector2D
    static member Zero : Vector2D
end

```

---

You can see that the Vector2D type contains the following:

- A collection of record fields
- One instance property (Length)
- Four instance methods (Scale, ShiftX, ShiftY, ShiftXY)
- One static property (Zero)
- Two static methods (ConstX, ConstY)

Let's look at the implementation of the Length property:

```
member v.Length = sqrt(v.DX * v.DX + v.DY * v.DY)
```

Here, the identifier `v` stands for the `Vector2D` value on which the property is being defined. In many other languages, this is called `this` or `self`, but in F# you can name this parameter as you see fit. The implementation of a property such as `Length` is executed each time the property is invoked; in other words, properties are syntactic sugar for method calls. For example, let's repeat the earlier type definition with an additional property that adds a side effect:

```
member v.LengthWithSideEffect =
    printfn "Computing!"
    sqrt(v.DX * v.DX + v.DY * v.DY)
```

Each time you use this property, you see the side effect:

---

```
> let x = {DX = 3.0; DY = 4.0};;
val x : Vector2D = {DX = 3.0; DY = 4.0;}
> x.LengthWithSideEffect;;
Computing!
val it : float = 5.0
> x.LengthWithSideEffect;;
Computing!
val it : float = 5.0
```

---

The method members for a type look similar to the properties but also take arguments. For example, let's look at the implementation of the `ShiftX` method member:

```
member v.ShiftX(x) = { v with DX = v.DX + x }
```

Here the object is `v`, and the argument is `dx`. The return result clones the input record value and adjusts the `DX` field to be `v.DX+dx`. Cloning records is described in Chapter 3. The `ShiftXY` method member takes two arguments:

```
member v.ShiftXY(x, y) = { DX = v.DX + x; DY = v.DY + y }
```

Like functions, method members can take arguments in either tupled or iterated form. For example, you could define `ShiftXY` as follows:

```
member v.ShiftXY x y = { DX = v.DX + x; DY = v.DY + y }
```

However, it's conventional for methods to take their arguments in tupled form. This is partly because OO programming is strongly associated with the design patterns and guidelines of the .NET Framework, and arguments always appear as tupled when using .NET methods from F#.

Discriminated unions are also a form of concrete type. In this case, the shape of the data associated with a value is drawn from a finite, fixed set of choices. Discriminated unions can also be given members. For example:

```

/// A type of binary trees, generic in the type of values carried at nodes and tips
type Tree<'T> =
    | Node of 'T * Tree<'T> * Tree<'T>
    | Tip

/// Compute the number of values in the tree
member t.Size =
    match t with
    | Node(_, l, r) -> 1 + l.Size + r.Size
    | Tip -> 0

```

---

### SHOULD YOU USE MEMBERS OR FUNCTIONS?

---

F# lets you define both members associated with types and objects via the dot-notation and static functions that can perform essentially the same operations. For example, the length of a string *s* can be computed by both the *s.Length* property and the *String.length* function. Given the choice, which should you use in your code? Although there is no fixed answer to this, here are some general rules:

- Use members (methods and properties) where they already exist, unless you have other good reasons not to do so. It's better to use *s.Length* than *String.length*, simply because it's shorter, even if it occasionally requires using an additional type annotation. That is, embrace dot-notation, but use it tastefully.
- When designing a framework or library, define members for the intrinsic, essential properties and operations associated with a type.
- When designing a framework or library, define additional functionality in new modules or by using extension members. The section “Extending Existing Types and Modules” later in this chapter covers extension members.

Sometimes there is duplication in functionality between dot-notation members and values in associated modules. This is intended and should be accepted as part of the mixed OO/functional nature of F#.

---

## Using Classes

Record and union types are symmetric: the values used to *construct* an object are the same as those *stored* in the object, which are a subset of those *published* by the object. This symmetry makes record and union types succinct and clear, and it helps give them other properties; for example, the F# compiler automatically derives generic equality, comparison, and hashing routines for these types.

However, more advanced object programming often needs to break these symmetries. For example, let's say you want to precompute and store the length of a vector in each vector value. It's clear you don't want everyone who creates a vector to have to perform this computation for you. Instead, you precompute the length as part of the construction sequence for the type. You can't do this using a record, except by using a helper function, so it's convenient to switch to a more general notation for *class types*. Listing 6-2 shows the *Vector2D* example using a class type.

*Listing 6-2. A Vector2D Type with Length Precomputation via a Class Type*

```

type Vector2D(dx : float, dy : float) =

    let len = sqrt(dx * dx + dy * dy)

    /// Get the X component of the vector
    member v.DX = dx

    /// Get the Y component of the vector
    member v.DY = dy

    /// Get the length of the vector
    member v.Length = len

    /// Return a vector scaled by the given factor
    member v.Scale(k) = Vector2D(k * dx, k * dy)

    /// Return a vector shifted by the given delta in the X coordinate
    member v.ShiftX(x) = Vector2D(dx = dx + x, dy = dy)

    /// Return a vector shifted by the given delta in the Y coordinate
    member v.ShiftY(y) = Vector2D(dx = dx, dy = dy + y)

    /// Return a vector that is shifted by the given deltas in each coordinate
    member v.ShiftXY(x, y) = Vector2D(dx = dx + x, dy = dy + y)

    /// Get the zero vector
    static member Zero = Vector2D(dx = 0.0, dy = 0.0)

    /// Get a constant vector along the X axis of length one
    static member OneX = Vector2D(dx = 1.0, dy = 0.0)

    /// Get a constant vector along the Y axis of length one
    static member OneY = Vector2D(dx = 0.0, dy = 1.0)

```

You can now use this type as follows:

---

```

> let v = Vector2D(3.0, 4.0);;
val v : Vector2D
> v.Length;;
val it : float = 5.0
> v.Scale(2.0).Length;;
val it : float = 10.0

```

---

Once again, it's helpful to look at the inferred type signature for the Vector2D type definition of Listing 6-2:

---

```

type Vector2D =
  class
    new : dx:float * dy:float -> Vector2D
    member Scale : k:float -> Vector2D
    member ShiftX : x:float -> Vector2D
    member ShiftXY : x:float * y:float -> Vector2D
    member ShiftY : y:float -> Vector2D
    member DX : float
    member DY : float
    member Length : float
    static member OneX : Vector2D
    static member OneY : Vector2D
    static member Zero : Vector2D
  end

```

---

The signature of the type is almost the same as that for Listing 6-1. The primary difference is in the construction syntax. Let's look at what's going on here. The first line says you're defining a type `Vector2D` with a *primary constructor*. This is sometimes called an *implicit constructor*. The constructor takes two arguments, `dx` and `dy`. The variables `dx` and `dy` are in scope throughout the (nonstatic) members of the type definition.

The second line is part of the computation performed each time an object of this type is constructed:

```
let len = sqrt(dx * dx + dy * dy)
```

Like the input values, the `len` value is in scope throughout the rest of the (nonstatic) members of the type. The next three lines publish both the input values and the computed length as properties:

```

member v.DX = dx
member v.DY = dy
member v.Length = len

```

The remaining lines implement the same methods and static properties as the original record type. The `Scale` method creates its result by calling the constructor for the type using the expression `Vector2D(k * dx, k * dy)`. In this expression, arguments are specified by position.

Class types with primary constructors always have the following form:

```

type TypeName <type-arguments> optional arguments [ as ident ] optional =
  [ inherit type [ as base ] optional ] optional
  [ let-binding | let-rec bindings ] zero-or-more
  [ do-statement ] zero-or-more
  [ abstract-binding | member-binding | interface-implementation ] zero-or-more

```

Later sections cover inheritance, abstract bindings, and interface implementations.

The `Vector2D` in Listing 6-2 uses a construction sequence. Construction sequences can enforce object invariants. For example, the following defines a vector type that checks that its length is close to 1.0 and refuses to construct an instance of the value if not:

```

/// Vectors whose length is checked to be close to length one.
type UnitVector2D(dx,dy) =
  let tolerance = 0.000001

  let length = sqrt (dx * dx + dy * dy)

```

```
do if abs (length - 1.0) >= tolerance then failwith "not a unit vector";

member v.DX = dx

member v.DY = dy

new() = UnitVector2D (1.0,0.0)
```

This example shows something else: sometimes it's convenient for a class to have multiple constructors. You do this by adding extra *explicit constructors* using a member named `new`. These must ultimately construct an instance of the object via the primary constructor. The inferred signature for this type contains two constructors:

---

```
type UnitVector2D =
  class
    new : unit -> UnitVector2D
    new : dx:float * dy:float -> UnitVector2D
    member DX : float
    member DY : float
  end
```

---

This represents a form of method overloading, covered in more detail in the “Adding Method Overloading” section later in this chapter.

Class types can also include static bindings. For example, this can be used to ensure only one vector object is allocated for the `Zero` and `One` properties of the vector type:

```
/// A class including some static bindings
type Vector2D(dx : float, dy : float) =

  static let zero = Vector2D(0.0, 0.0)
  static let onex = Vector2D(1.0, 0.0)
  static let oney = Vector2D(0.0, 1.0)

  /// Get the zero vector
  static member Zero = zero

  /// Get a constant vector along the X axis of length one
  static member OneX = onex

  /// Get a constant vector along the Y axis of length one
  static member OneY = oney
```

Static bindings in classes are initialized once, along with other module and static bindings in the file. If the class type is generic, it's initialized once per concrete type generic instantiation.

## Adding Further Object Notation to Your Types

As we mentioned, one of the most useful aspects of object programming is the notational convenience of dot-notation. This extends to other kinds of notation, in particular `expr.[expr]` *indexer* notation, named



arguments, optional arguments, operator overloading, and method overloading. The following sections cover how to define and use these notational conveniences.

## Working with Indexer Properties

Like methods, properties can take arguments; these are called *indexer* properties. The most commonly defined indexer property is called `Item`, and the `Item` property on a value `v` is accessed via the special notation `v.[i]`. As the notation suggests, these properties are normally used to implement the lookup operation on collection types. The following example implements a sparse vector in terms of an underlying sorted dictionary:

```
open System.Collections.Generic

type SparseVector(items : seq<int * float>)=
    let elems = new SortedDictionary<_,_>()
    do items |> Seq.iter (fun (k, v) -> elems.Add(k, v))

    /// This defines an indexer property
    member t.Item
        with get(idx) =
            if elems.ContainsKey(idx) then elems.[idx]
            else 0.0
```

You can define and use the indexer property as follows:

---

```
> let v = SparseVector [(3, 547.0)];;
val v : SparseVector
> v.[4];;
val it : float = 0.0
> v.[3];;
val it : float = 547.0
```

---

You can also use indexer properties as mutable setter properties with the syntax `expr.[expr] <- expr`. This is covered in the section “Defining Object Types with Mutable State.” Indexer properties can also take multiple arguments; for example, the indexer property for the F# Power Pack type `Microsoft.FSharp.Math.Matrix<'T>` takes two arguments. Chapter 10 describes this type.

## Adding Overloaded Operators

Types can also include the definition of overloaded operators. Typically, you do this by defining static members with the same names as the relevant operators. Here is an example:

```
type Vector2DWithOperators(dx : float, dy : float) =
    member x.DX = dx
    member x.DY = dy

    static member (+) (v1 : Vector2DWithOperators, v2 : Vector2DWithOperators) =
```

```

    Vector2DWithOperators(v1.DX + v2.DX, v1.DY + v2.DY)

    static member (-) (v1 : Vector2DWithOperators, v2 : Vector2DWithOperators) =
        Vector2DWithOperators (v1.DX - v2.DX, v1.DY - v2.DY)

```

---

```

> let v1 = new Vector2DWithOperators (3.0, 4.0);;
val v1 : Vector2DWithOperators
> v1 + v1;;
val it : Vector2DWithOperators = {DX = 6.0; DY = 8.0;}
> v1 - v1;;
val it : Vector2DWithOperators = {DX = 6.0; DY = 8.0;}

```

---

If you add overloaded operators to your type, you may also have to customize how generic equality, hashing, and comparison are performed. In particular, the behavior of generic operators such as `hash`, `<`, `>`, `<=`, `>=`, `compare`, `min`, and `max` isn't specified by defining new static members with these names, but rather by the techniques described in Chapter 9.

---

## HOW DOES OPERATOR OVERLOADING WORK?

---

Operator overloading in F# works by having fixed functions that map uses of operators through to particular static members on the static types involved in the operation. These functions are usually defined in the F# library. For example, the F# library includes the following definition for the (+) operator:

```
let inline (+) x y = ((^a or ^b): (static member (+) : ^a * ^b -> ^c) (x,y))
```

This defines the infix function (+) and is implemented using a special expression that says “implement `x + y` by calling a static member (+) on the type of the left or right operand.” The function is marked inline to ensure that F# can always check for the existence of this member and call it efficiently. When you name a static member (+), then that is really shorthand for the name `op_Addition`, which is the .NET standard encoded name for addition operators.

You can define your own operators if you want, but they aren't automatically overloaded in the same way as F# library definitions like the one shown previously. For example, the following defines a new infix operator that appends a single element to the end of a list:

```
let (++) x y = List.append x [y]
```

This operator isn't overloaded; it's a single fixed function. Defining non-overloaded operators can help make some implementation code more succinct, and you use this technique in the symbolic programming examples in Chapter 12.

In principle, you can define new operators that are truly overloaded in the same way as the definition of (+) in the F# library, mapping the operator across to particular static members. However, code is generally much clearer if you stick to the standard overloaded operators.

---

## Using Named and Optional Arguments

The F# object programming constructs are designed largely for use in APIs for software components. Two useful mechanisms in APIs permit callers to name arguments and let API designers make certain arguments optional.

Named arguments are simple. For example, in Listing 6-2, the implementations of some methods specify arguments by name, as in the expression `Vector2D(dx=dx+x, dy=dy)`. You can use named arguments with all dot-notation method calls. Code written using named arguments is often much more readable and maintainable than code relying on argument position. The rest of this book frequently uses named arguments.

You declare a member argument optional by prefixing the argument name with `?`. Within a function implementation, an optional argument always has an `option<_>` type; for example, an optional argument of type `int` appears as a value of type `option<int>` within the function body. The value is `None` if no argument is supplied by the caller and `Some(arg)` if the argument `arg` is given by the caller. For example:

```
open System.Drawing
```

```
type LabelInfo(?text : string, ?font : Font) =
    let text = defaultArg text ""
    let font = match font with
                | None -> new Font(FontFamily.GenericSansSerif, 12.0f)
                | Some v -> v
    member x.Text = text
    member x.Font = font

    /// Define a static method which creates an instance
    static member Create(?text, ?font) = new LabelInfo(?text=text, ?font=font)
```

The inferred signature for this type shows how the optional arguments have become named arguments accepting option values:

---

```
type LabelInfo =
    new : ?text:string * ?font:System.Drawing.Font -> LabelInfo
    static member Create : ?text:string * ?font:System.Drawing.Font -> LabelInfo
    member Font : System.Drawing.Font
    member Text : string
```

---

You can now create `LabelInfo` values using several different techniques:

---

```
> LabelInfo (text="Hello World");;
val it : LabelInfo = LabelInfo {Font = [Font: Name=Microsoft Sans Serif, Size=12, ...];}
> LabelInfo("Goodbye Lenin");;
val it : LabelInfo = LabelInfo {Font = [Font: Name=Microsoft Sans Serif, Size=12 ...];}
> LabelInfo(font = new Font(FontFamily.GenericMonospace, 36.0f),
            text = "Imagine");;
val it : LabelInfo = LabelInfo {Font = [Font: Name=Courier New, Size=36, ...];}
```

---

Optional arguments must always appear last in the set of arguments accepted by a method. They're usually used as named arguments by callers. At the callsite, this is done using the syntax *argument-name* = *argument-value*. If the argument has type *T option*, then *argument-value* must have type *T*.

In the example, you see the static member `Create` which also takes optional arguments, the code for which is repeated below.

```
type LabelInfo ... =
    ...

    /// Define a static method which creates an instance
    static member Create(?text, ?font) = new LabelInfo(?text = text, ?font = font)
```

This represents a common pattern when using optional arguments heavily within a framework implementation: one method taking optional arguments is defined in terms of another. The implementation of the `Create` method simply passes the optional arguments through to be optional arguments of the constructor. At the callsite, this is done using the syntax *?argument-name* = *argument-value*. Note the extra question mark at the callsite! If the argument has type *T option*, then *argument-value* must have type *T option* as well.

The implementation of `LabelInfo` uses the F# library function `defaultArg`, which is a useful way to specify simple default values for optional arguments. Its type is as follows:

---

```
val defaultArg : 'T option -> 'T-> 'T
```

---

■ **Note** The second argument given to the `defaultArg` function is evaluated *before* the function is called. This means you should take care that this argument isn't expensive to compute and doesn't need to be disposed. The previous example uses a match expression to specify the default for the `font` argument for this reason.

---

## Adding Method Overloading

.NET APIs and other object frameworks frequently use a notational device called *method overloading*. This means a type can support multiple methods with the same name, and uses of methods are distinguished by name, number of arguments, and argument types. For example, the `System.Console.WriteLine` method of .NET has 19 overloads!

Method overloading is used relatively rarely in F#-authored classes, partly because optional arguments and mutable property setters tend to make it less necessary. However, method overloading is permitted in F#. First, methods can easily be overloaded by the number of arguments. For example, Listing 6-3 shows a concrete type representing an interval of numbers on the number line. It includes two methods called `Span`, one taking a pair of intervals and the other taking an arbitrary collection of intervals. The overloading is resolved according to argument count.

### Listing 6-3. An Interval Type with Overloaded Methods

```
/// Interval(lo,hi) represents the range of numbers from lo to hi,
/// but not including either lo or hi.
type Interval(lo, hi) =
    member r.Lo = lo
```

```

member r.Hi = hi
member r.IsEmpty = hi <= lo
member r.Contains v = lo < v && v < hi

static member Empty = Interval(0.0, 0.0)

/// Return the smallest interval that covers both the intervals
/// This method is overloaded.
static member Span (r1 : Interval, r2 : Interval) =
    if r1.IsEmpty then r2 else
    if r2.IsEmpty then r1 else
    Interval(min r1.Lo r2.Lo, max r1.Hi r2.Hi)

/// Return the smallest interval that covers all the intervals
/// This method is overloaded.
static member Span(ranges : seq<Interval>) =
    Seq.fold (fun r1 r2 -> Interval.Span(r1, r2)) Interval.Empty ranges

```

Second, multiple methods can also have the same number of arguments and be overloaded by type. One of the most common examples is providing multiple implementations of overloaded operators on the same type. The following example shows a `Point` type that supports two subtraction operations, one subtracting a `Point` from a `Point` to give a `Vector` and one subtracting a `Vector` from a `Point` to give a `Point`:

```

type Vector =
    { DX : float; DY : float }
    member v.Length = sqrt( v.DX * v.DX + v.DY * v.DY)

type Point =
    { X : float; Y : float }

static member (-) (p1 : Point, p2 : Point) =
    { DX = p1.X - p2.X; DY = p1.Y - p2.Y }

static member (-) (p : Point, v : Vector) =
    { X = p.X - v.DX; Y = p.Y - v.DY }

```

Overloads must be unique by signature, and you should take care to make sure your overload set isn't too ambiguous—the more overloads you use, the more type annotations users of your types will need to add.

## Defining Object Types with Mutable State

All the types you've seen so far in this chapter have been immutable. For example, the values of the `Vector2D` types shown in Listing 6-1 and Listing 6-2 can't be modified after they're created. Sometimes you may need to define mutable objects, particularly because object programming is a generally useful technique for encapsulating mutable and evolving state. Listing 6-4 shows the definition of a mutable representation of a 2D vector.

*Listing 6-4. An Object Type with State*

```

type MutableVector2D(dx : float, dy : float) =
  let mutable currDX = dx
  let mutable currDY = dy

  member vec.DX with get() = currDX and set v = currDX <- v
  member vec.DY with get() = currDY and set v = currDY <- v

  member vec.Length
    with get () = sqrt (currDX * currDX + currDY * currDY)
    and set len =
      let theta = vec.Angle
      currDX <- cos theta * len
      currDY <- sin theta * len

  member vec.Angle
    with get () = atan2 currDY currDX
    and set theta =
      let len = vec.Length
      currDX <- cos theta * len
      currDY <- sin theta * len

```

The mutable state is held in two mutable local let bindings for currDX and currDY. It also exposes additional settable properties, Length and Angle, that interpret and adjust the underlying currDX/currDY values. Here is the inferred signature for the type:

---

```

type MutableVector2D =
  class
    new : dx:float * dy:float -> MutableVector2D
    member Angle : float
    member DX : float
    member DY : float
    member Length : float
    member Angle : float with set
    member DX : float with set
    member DY : float with set
    member Length : float with set
  end

```

---

You can use this type as follows:

---

```

> let v = MutableVector2D(3.0, 4.0);;
val v : MutableVector2D
> (v.DX, v.DY);;
val it : float * float = (3.0, 4.0)
> (v.Length, v.Angle);;
val it : float * float = (5.0, 0.927295218)

```

```

> v.Angle <- System.Math.PI / 6.0;;      // "30 degrees"
> (v.DX, v.DY);;
val it : float * float = (4.330127019, 2.5)
> (v.Length, v.Angle);;
val it : float * float = (5.0, 0.523598775)

```

---

Adjusting the `Angle` property rotates the vector while maintaining its overall length. This example uses the long syntax for properties, where you specify both set and get operations for the property.

If the type has an indexer (`Item`) property, then you write an indexed setter as follows:

```

open System.Collections.Generic
type IntegerMatrix(rows : int, cols : int)=
    let elems = Array2D.zeroCreate<int> rows cols

    /// This defines an indexer property with getter and setter
    member t.Item
        with get (idx1, idx2) = elems.[idx1, idx2]
         and set (idx1, idx2) v = elems.[idx1, idx2] <- v

```

---

■ **Note** Class types with a primary constructor are useful partly because they implicitly *encapsulate* internal functions and mutable state. This is because all the construction arguments and `let` bindings are private to the object instance being constructed. This is just one of the ways of encapsulating information in F# programming. Chapter 7 covers encapsulation more closely.

---



---

## OBJECTS AND MUTATION

---

Object programming was originally developed as a technique for controlling the complexity of mutable state. However, many of the concerns of object programming are orthogonal to this. For example, programming constructs such as object interface types, inheritance, and higher-level design patterns such as `publish/subscribe` stem from the OO tradition, whereas techniques such as functions, type abstraction, and aggregate operations such as `map` and `fold` stem from the functional programming tradition. Many object programming techniques have no fundamental relationship to object mutation and identity; for example, interfaces and inheritance can be used very effectively with immutable objects. Much of the expressivity of F# lies in the way it brings the techniques of object programming and functional programming comfortably together.

---

## Using Optional Property Settings

Throughout this book, you've used a second technique to specify configuration parameters when creating objects: *initial property settings* for objects. For example, in Chapter 2, you used the following code:

```

open System.Windows.Forms
let form = new Form(Visible = true, TopMost = true, Text = "Welcome to F#")

```

The constructor for the `System.Windows.Forms.Form` class takes no arguments, so in this case the named arguments indicate set operations for the given properties. The code is shorthand for this:

```
open System.Windows.Forms

let form =
    let tmp = new Form()
    tmp.Visible <- true
    tmp.TopMost <- true
    tmp.Text <- "Welcome to F#"
    tmp
```

The F# compiler interprets unused named arguments as calls that set properties of the returned object. This technique is widely used for mutable objects that evolve over time, such as graphical components, because it greatly reduces the number of optional arguments that need to be plumbed around.

Here's how to define a version of the `LabelInfo` type used earlier that is configurable by optional property settings:

```
open System.Drawing

type LabelInfoWithPropertySetting() =
    let mutable text = "" // the default
    let mutable font = new Font(FontFamily.GenericSansSerif, 12.0f)
    member x.Text with get() = text and set v = text <- v
    member x.Font with get() = font and set v = font <- v

> LabelInfoWithPropertySetting(Text="Hello World");;

let form = new Form(Visible = true, TopMost = true, Text = "Welcome to F#")
```

The “Defining Object Types with Mutable State” section later in this chapter covers mutable objects in more detail.

## Declaring Auto-Properties

When declaring properties, especially settable ones, a common pattern occurs where the property storage is defined, the initial value for the property is specified, and the member to allow external access to the property is defined. This has a more convenient syntactic declaration form called an auto-property. An auto-property declaration has the form `member val id = expr` followed by an optional `with get, set` if the property storage is mutable and a property setter should be exported. An example is shown below, defining the same type as above.

```
type LabelInfoWithPropertySetting() =
    member val Name = "label"
    member val Text = "" with get, set
    member val Font = new Font(FontFamily.GenericSansSerif, 12.0f) with get, set
```

Note that the initializer for an auto-property is executed once per object, when the object is initialized. Auto-properties can also be static.



## Getting Started with Object Interface Types

So far in this chapter, you've seen only how to define *concrete* object types. One of the key advances in both functional and object-oriented programming has been the move toward using *abstract* types for large portions of modern software. These values are typically accessed via *interfaces*, and you now look at defining new *object interface types*.

The notion of an object interface type can sound a little daunting at first, but the concept is actually simple; object interface types are ones whose member implementations can vary from value to value. As it happens, you've already met one important family of types whose implementations also vary from value to value: F# function types!

- In Chapter 3, you saw how functions can be used to model a range of concepts such as comparison functions, aggregation functions, and transformation functions.
- In Chapter 5, you saw how records of function values can be used for the parameters needed to make an algorithm generic.

You've also already met some other important object interface types such as `System.Collections.Generic.IEnumerable<'T>` and `System.IDisposable`. .NET object interface types always begin with the letter I.

Object interface types are always *implemented*, and the type definition itself doesn't specify how this is done. Listing 6-5 shows an object interface type `IShape` and a number of implementations of it. This section walks through the definitions in this code piece by piece, because they illustrate the key concepts behind object interface types and how they can be implemented.

*Listing 6-5. An Object Interface Type IShape and Some Implementations*

```
open System.Drawing
type IShape =
    abstract Contains : Point -> bool
    abstract BoundingBox : Rectangle

let circle (center : Point, radius : int) =
    { new IShape with
        member x.Contains(p : Point) =
            let dx = float32 (p.X - center.X)
            let dy = float32 (p.Y - center.Y)
            sqrt(dx * dx + dy * dy) <= float32 radius

        member x.BoundingBox =
            Rectangle(
                center.X - radius, center.Y - radius,
                2 * radius + 1, 2 * radius + 1)}

let square (center : Point, side : int) =
    { new IShape with
        member x.Contains(p : Point) =
            let dx = p.X - center.X
            let dy = p.Y - center.Y
            abs(dx) < side / 2 && abs(dy) < side / 2

        member x.BoundingBox =
            Rectangle(center.X - side, center.Y - side, side * 2, side * 2)}
```

```

type MutableCircle() =
  member val Center = Point(x = 0, y = 0) with get, set
  member val Radius = 10 with get, set

  member c.Perimeter = 2.0 * System.Math.PI * float c.Radius

  interface IShape with
    member c.Contains(p : Point) =
      let dx = float32 (p.X - c.Center.X)
      let dy = float32 (p.Y - c.Center.Y)
      sqrt(dx * dx + dy * dy) <= float32 c.Radius

    member c.BoundingBox =
      Rectangle(
        c.Center.X - c.Radius, c.Center.Y - c.Radius,
        2 * c.Radius + 1, 2 * c.Radius + 1)

```

## Defining New Object Interface Types

The key definition in Listing 6-5 is the following (it also uses `Rectangle` and `Point`, two types from the `System.Drawing` namespace):

```

open System.Drawing
type IShape =
  abstract Contains : Point -> bool
  abstract BoundingBox : Rectangle

```

Here you use the keyword `abstract` to define the member signatures for this type, indicating that the implementation of the member may vary from value to value. Also note that `IShape` isn't concrete; it's neither a record nor a discriminated union or class type. It doesn't have any constructors and doesn't accept any arguments. This is how F# infers that it's an object interface type.

## Implementing Object Interface Types Using Object Expressions

The following code from Listing 6-5 implements the object interface type `IShape` using an *object expression*:

```

let circle(center : Point, radius : int) =
  { new IShape with

    member x.Contains(p : Point) =
      let dx = float32 (p.X - center.X)
      let dy = float32 (p.Y - center.Y)
      sqrt(dx * dx + dy * dy) <= float32 radius

    member x.BoundingBox =
      Rectangle(
        center.X - radius, center.Y - radius,
        2 * radius + 1, 2 * radius + 1)}

```

The type of the function `circle` is as follows:

---

```
val circle : center:Point * radius:int -> IShape
```

---

The construct in the braces, { new IShape with ... }, is the object expression. This is a new expression form that you haven't encountered previously in this book, because it's generally used only when implementing object interface types. An object expression must give implementations for all the members of an object interface type. The general form of this kind of expression is simple:

```
{ new Type optional-arguments with
  member-definitions
  optional-extra-interface-definitions }
```

The member definitions take the same form as members for type definitions described earlier in this chapter. The optional arguments are given only when object expressions inherit from a class type, and the optional interface definitions are used when implementing additional interfaces that are part of a hierarchy of object interface types.

You can use the function `circle` as follows:

---

```
> let bigCircle = circle(Point(0, 0), 100);;
val bigCircle : IShape
> bigCircle.BoundingBox;;
val it : Rectangle = {X=-100,Y=-100,Width=201,Height=201}
> bigCircle.Contains(Point(70, 70));;
val it : bool = true
> bigCircle.Contains(Point(71, 71));;
val it : bool = false
```

---

Listing 6-5 also contains another function `square` that gives a different implementation for `IShape`, also using an object expression:

---

```
> let smallSquare = square(Point(1, 1), 1);;
val smallSquare : IShape
> smallSquare.BoundingBox;;
val it : Rectangle = {X=0,Y=0,Width=2,Height=2}
> smallSquare.Contains(Point(0,0));;
val it : bool = false
```

---

■ **Note** In object-oriented languages, implementing types in multiple ways is commonly called *polymorphism*, which you may call *polymorphism of implementation*. Polymorphism of this kind is present throughout F#, and not just with respect to the object constructs. In functional programming, the word *polymorphism* is used to mean generic type parameters. These are an orthogonal concept discussed in Chapters 2 and 5.

---

## Implementing Object Interface Types Using Concrete Types

It's common to have concrete types that both implement one or more object interface types and provide additional services of their own. Collections are a primary example, because they always implement `IEnumerable<'T>`. To give another example, in Listing 6-5 the type `MutableCircle` is defined as follows:

```
type MutableCircle() =
    let radius = 0
    member val Center = Point(x = 0, y = 0) with get, set
    member val Radius = radius with get, set
    member c.Perimeter = 2.0 * System.Math.PI * float radius

    interface IShape with
        member c.Contains(p : Point) =
            let dx = float32 (p.X - c.Center.X)
            let dy = float32 (p.Y - c.Center.Y)
            sqrt(dx * dx + dy * dy) <= float32 c.Radius

        member c.BoundingBox =
            Rectangle(
                c.Center.X - c.Radius, c.Center.Y - c.Radius,
                2 * c.Radius + 1, 2 * c.Radius + 1)
```

This type implements the `IShape` interface, which means `MutableCircle` is a subtype of `IShape`, but it also provides three properties—`Center`, `Radius`, and `Perimeter`—that are specific to the `MutableCircle` type, two of which are settable. The type has the following signature:

---

```
type MutableCircle =
    interface IShape
    new : unit -> MutableCircle
    member Perimeter : float
    member Center : Point with get, set
    member Radius : int with get, set
```

---

You can now reveal the interface (through a type cast) and use its members. For example:

---

```
> let circle2 = MutableCircle();;
val circle2 : MutableCircle
> circle2.Radius;;
val it : int = 10
> (circle2 :> IShape).BoundingBox;;
val it : Rectangle = {X=-10,Y=-10,Width=21,Height=21}
```

---

## Using Common Object Interface Types from the .NET Libraries

Like other constructs discussed in this chapter, object interface types are often encountered when using .NET libraries. Some object interface types such as `IEnumerable<'T>` (called `seq<'T>` in F# coding) are also

used throughout F# programming. It's a .NET convention to prefix the name of all object interface types with I. However, using object interface types is very common in F# object programming, so this convention isn't always followed.

Here's the essence of the definition of the `System.Collections.Generic.IEnumerable<'T>` type and the related type `IEnumerator` using F# notation:

```
type IEnumerator<'T> =
    abstract Current : 'T
    abstract MoveNext : unit -> bool

type IEnumerable<'T> =
    abstract GetEnumerator : unit -> IEnumerator<'T>
```

The `IEnumerable<'T>` type is implemented by most concrete collection types. It can also be implemented by a sequence expression or by calling a library function such as `Seq.unfold`, which in turn uses an object expression as part of its implementation.

---

■ **Note** The `IEnumerator<'T>` and `IEnumerable<'T>` interfaces are defined in a library component that is implemented using another .NET language. This section uses the corresponding F# syntax. In reality, `IEnumerator<'T>` also inherits from the nongeneric interface `System.Collections.IEnumerator` and the type `System.IDisposable`, and `IEnumerable<'T>` also inherits from the nongeneric interface `System.Collections.IEnumerable`. For clarity, we've ignored this. See the F# library documentation for full example implementations of these types.

---

Some other useful predefined F# and .NET object interface types are as follows:

- `System.IDisposable`: Represents values that may own explicitly reclaimable resources.
- `System.IComparable` and `System.IComparable<'T>`: Represent values that can be compared to other values. F# generic comparison is implemented via these types, as you see in Chapter 9.
- `Microsoft.FSharp.Control.IEvent`: Represents mutable ports into which you can plug event listeners, or *callbacks*. This technique is described in Chapter 11. Some other entity is typically responsible for raising the event and thus calling all the listener callbacks. In F#, .NET events become values of this type or the related type `Microsoft.FSharp.Control.IDelegateEvent`, and the module `Microsoft.FSharp.Control.Event` contains many useful functions for manipulating these values. You can open this module by using `open Event`.

## Understanding Hierarchies of Object Interface Types

Object interface types can be arranged in hierarchies using *interface inheritance*. This provides a way to classify types. To create a hierarchy, you use the `inherit` keyword in an object interface type definition along with each parent object interface type. For example, the .NET Framework includes a hierarchical classification of collection types: `ICollection<'T>` extends `IEnumerable<'T>`. Here are the essential definitions of these types in F# syntax, with some minor details omitted:

```

type IEnumerable<'T> =
    abstract GetEnumerator : unit -> IEnumerator<'T>

type ICollection<'T> =
    inherit IEnumerable<'T>
    abstract Count : int
    abstract IsReadOnly : bool
    abstract Add : 'T -> unit
    abstract Clear : unit -> unit
    abstract Contains : 'T -> bool
    abstract CopyTo : 'T [] * int -> unit
    abstract Remove : 'T -> unit

```

When you implement an interface that inherits from another interface, you must effectively implement both interfaces.

---

■ **Caution** Although hierarchical modeling is useful, you must use it with care: poorly designed hierarchies often have to be abandoned late in the software development life cycle, leading to major disruptions. For many applications, it's adequate to use existing classification hierarchies in conjunction with some new nonhierarchical interface types.

---

## More Techniques to Implement Objects

Objects can be difficult to implement from scratch; for example, a graphical user interface (GUI) component must respond to many different events, often in regular and predictable ways, and it would be tedious to have to recode all this behavior for each component. This makes it essential to support the process of creating partial implementations of objects, where the *partial implementations* can then be completed or customized. The following sections cover techniques to build partial implementations of objects.

### Combining Object Expressions and Function Parameters

One of the easiest ways to build a partial implementation of an object is to qualify the implementation of the object by a number of function parameters that complete the implementation. For example, the following code defines an object interface type called `ITextOutputSink`, a partial implementation of that type called `simpleOutputSink`, and a function called `simpleOutputSink` that acts as a partial implementation of that type. The remainder of the implementation is provided by a function parameter called `writeCharFunction`:

```

/// An object interface type that consumes characters and strings
type ITextOutputSink =

    /// When implemented, writes one Unicode character to the sink
    abstract WriteChar : char -> unit

    /// When implemented, writes one Unicode string to the sink
    abstract WriteString : string -> unit

```

```

/// Returns an object that implements ITextOutputSink by using writeCharFunction
let simpleOutputSink writeCharFunction =
    { new ITextOutputSink with
        member x.WriteChar(c) = writeCharFunction c
        member x.WriteString(s) = s |> String.iter x.WriteChar }

```

This construction function uses function values to build an object of a given shape. Here the inferred type is as follows:

---

```

val simpleOutputSink : writeCharFunction:(char -> unit) -> ITextOutputSink

```

---

The following code instantiates the function parameter to output the characters to a particular `System.Text.StringBuilder` object, an imperative type for accumulating characters in a buffer before converting these to an immutable `System.String` value:

```

let stringBuilderOutputSink (buf : System.Text.StringBuilder ) =
    simpleOutputSink (fun c -> buf.Append(c) |> ignore)

```

Here is an example that uses this function interactively:

---

```

> let buf = new System.Text.StringBuilder();
val buf : StringBuilder =
> let c = stringBuilderOutputSink(buf);
val c : ITextOutputSink
> ["Incy"; " "; "Wincy"; " "; "Spider"] |> List.iter c.WriteString;;
> buf.ToString();
val it : string = "Incy Wincy Spider"

```

---

Object expressions must give definitions for all unimplemented abstract members and can't add other members.

One powerful technique implements some or all abstract members in terms of function parameters. As you saw in Chapter 3, function parameters can represent a wide range of concepts. For example, here is a type `CountingOutputSink` that performs the same role as the earlier function `simpleOutputSink`, except that the number of characters written to the sink is recorded and published as a property:

```

/// A type which fully implements the ITextOutputSink object interface
type CountingOutputSink(writeCharFunction : char -> unit) =

    let mutable count = 0

    interface ITextOutputSink with
        member x.WriteChar(c) = count <- count + 1; writeCharFunction(c)
        member x.WriteString(s) = s |> String.iter (x :> ITextOutputSink).WriteChar

    member x.Count = count

```

---

■ **Note** Qualifying object implementations by function parameters can be seen as a simple form of the OO design pattern known as *delegation*, because parts of the implementation are delegated to the function values. Delegation is a powerful and compositional technique for reusing fragments of implementations and is commonly used in F# as a replacement for OO implementation inheritance.

---

## Defining Partially Implemented Class Types

In this chapter, you've seen how to define concrete types, such as `Vector2D` in Listings 6-2 and 6-3, and you've seen how to define object interface types, such as `IShape` in Listing 6-5. Sometimes it's useful to define types that are halfway between these types: *partially concrete types*. Partially implemented types are class types that also have abstract members, some of which may be unimplemented and some of which may have default implementations. For example, consider the following class:

```
/// A type whose members are partially implemented
[<AbstractClass>]
type TextOutputSink() =
    abstract WriteChar : char -> unit
    abstract WriteString : string -> unit
    default x.WriteString s = s |> String.iter x.WriteChar
```

This class defines two abstract members, `WriteChar` and `WriteString`, but gives a default implementation for `WriteString` in terms of `WriteChar`. (In C# terminology, `WriteString` is virtual and `WriteChar` is abstract). Because `WriteChar` isn't yet implemented, you can't create an instance of this type directly; unlike other concrete types, partially implemented types still need to be implemented. One way to do this is to complete the implementation via an object expression. For example:

```
{ new TextOutputSink() with
    member x.WriteChar c = System.Console.Write(c)}
```

## Using Partially Implemented Types via Delegation

This section covers how you can use partially implemented types to build complete objects. One approach is to instantiate one or more partially implemented types to put together a complete concrete type. This is often done via delegation to an instantiation of the partially concrete type; for example, the following example creates a private, internal `TextOutputSink` object whose implementation of `WriteChar` counts the number of characters written through that object. You use this object to build the `HtmlWriter` object that publishes three methods specific to the process of writing a particular format:

```
/// A type which uses a TextOutputSink internally
type HtmlWriter() =
    let mutable count = 0
    let sink =
        { new TextOutputSink() with
            member x.WriteChar c =
                count <- count + 1;
                System.Console.Write c }
```



```

member x.CharCount = count
member x.OpenTag(tagName) = sink.WriteString(sprintf "<%s>" tagName)
member x.CloseTag(tagName) = sink.WriteString(sprintf "</%s>" tagName)
member x.WriteString(s) = sink.WriteString(s)

```

## Using Partially Implemented Types via Implementation Inheritance

Another technique to use partially implemented types is called *implementation inheritance*, which is widely used in OO languages despite being a somewhat awkward technique. Implementation inheritance tends to be much less significant in F# because it comes with major drawbacks:

- Implementation inheritance takes base objects and makes a new type that is more complex, by adding new members. This is against the spirit of functional programming, where the aim is to build simple, composable abstractions. Functional programming, object expressions, and delegation tend to provide good alternative techniques for defining, sharing, and combining implementation fragments.
- Implementation hierarchies tend to leak across API boundaries, revealing how objects are implemented rather than how they can be used and composed.
- Implementation hierarchies are often fragile in response to minor changes in program specification. There is pressure on developers to put too much functionality in base classes, anticipating the needs of all derivations. There's also pressure to go back and change the base class as new needs arise. This gives rise to the “fragile base class” problem, a major curse of object-oriented programming.

If implementation inheritance is used, you should in many cases consider making all implementing classes private or hiding all implementing classes behind a signature. For example, the `Microsoft.FSharp.Collections.Seq` module provides many implementations of the `seq<'T>` interface but exposes no implementation inheritance.

Nevertheless, hierarchies of classes are important in domains such as GUI programming, and the technique is used heavily by .NET libraries written in other .NET languages. For example, `System.Windows.Forms.Control`, `System.Windows.Forms.UserControl`, and `System.Windows.Forms.RichTextBox` are part of a hierarchy of visual GUI elements. Should you want to write new controls, then you must understand this implementation hierarchy and how to extend it. However, even in this domain, implementation inheritance is often less important than you may think, because these controls can often be configured in powerful and interesting ways by adding function callbacks to events associated with the controls.

Here is a simple example of applying the technique to instantiate and extend the partially implemented type `TextOutputSink`:

```

/// An implementation of TextOutputSink, counting the number of bytes written
type CountingOutputSinkByInheritance() =
    inherit TextOutputSink()

    let mutable count = 0

    member sink.Count = count

    default sink.WriteChar c =
        count <- count + 1;
        System.Console.Write c

```

The keywords `override` and `default` can be used interchangeably; both indicate that an implementation is being given for an abstract member. By convention, `override` is used when giving implementations for abstract members in inherited types that already have implementations, and `default` is used for implementations of abstract members that didn't previously have implementations.

Implementations are also free to override and modify default implementations such as the implementation of `WriteString` provided by `TextOutputSink`. Here is an example:

```
{ new TextOutputSink() with
  member sink.WriteChar c = System.Console.Write c
  member sink.WriteString s = System.Console.Write s }
```

You can also build new partially implemented types by extending existing partially implemented types. The following example takes the `TextOutputSink` type from the previous section and adds two abstract members called `WriteByte` and `WriteBytes`, adds a default implementation for `WriteBytes`, adds an initial implementation for `WriteChar`, and overrides the implementation of `WriteString` to use `WriteBytes`. The implementations of `WriteChar` and `WriteString` use the .NET functionality to convert the Unicode characters and strings to bytes under `System.Text.UTF8Encoding`, documented in the .NET Framework class libraries:

```
open System.Text

/// A component to write bytes to an output sink
[<AbstractClass>]
type ByteOutputSink() =
  inherit TextOutputSink()

  /// When implemented, writes one byte to the sink
  abstract WriteByte : byte -> unit

  /// When implemented, writes multiple bytes to the sink
  abstract WriteBytes : byte[] -> unit

  default sink.WriteChar c = sink.WriteBytes(Encoding.UTF8.GetBytes [|c|])

  override sink.WriteString s = sink.WriteBytes(Encoding.UTF8.GetBytes s)

  default sink.WriteBytes b = b |> Array.iter sink.WriteByte
```

## Combining Functional and Objects: Cleaning Up Resources

Many constructs in the `System.IO` namespace need to be closed after use, partly because they hold on to operating-system resources such as file handles. This is an example where objects are used to encapsulate and manage resource lifetime. In polished code, you use language constructs such as `use val = expr` to ensure that the resource is closed at the end of the lexical scope where a stream object is active. For example:

```
let myWriteStringToFile() =
  use outp = File.CreateText("playlist.txt")
  outp.WriteLine("Enchanted")
  outp.WriteLine("Put your records on")
```

This is equivalent to the following:

```

let myWriteStringToFile () =
    let outp = File.CreateText("playlist.txt")
    try
        outp.WriteLine("Enchanted")
        outp.WriteLine("Put your records on")
    finally
        (outp :> System.IDisposable).Dispose()

```

Both forms ensure that the underlying stream is closed deterministically and the operating system resources are reclaimed when the lexical scope is exited. The longer form uses the `:>` operator to call `Dispose`, explained further in Chapter 5. This happens regardless of whether the scope is exited because of normal termination or because of an exception.

---

■ **Note:** If you don't use `using` or otherwise explicitly close the stream, the stream is closed when the stream object is finalized by the .NET garbage collector. It's generally bad practice to rely on finalization to clean up resources this way, because finalization isn't guaranteed to happen in a deterministic, timely fashion.

---

## Resources and IDisposable

All programming involves the use of real resources on the host machine(s) and operating system. For example:

- *Stack:* Implicitly allocated and deallocated as functions are called
- *Heap allocated memory:* Used by all reference-typed objects
- *File handles:* Such as operating-system file handles represented by `System.IO.FileStream` objects and its subtypes
- *Network connections:* Such as operating system I/O completion ports represented by `System.Net.WebResponse` and its subtypes
- *Threads:* Such as operating-system threads represented by `System.Threading.Thread` objects and also worker threads in the .NET thread pool
- *Graphics objects:* Such as drawing objects represented by various constructs under the `System.Drawing` namespace
- *Concurrency objects:* Such as operating-system synchronization objects represented by `System.Threading.WaitHandle` objects and its subtypes

All resources are necessarily finite. In .NET programming, some resources such as memory are fully *managed*, in the sense that you almost never need to consider when to clean up memory. This is done automatically through a process called *garbage collection*. Chapter 18 looks at garbage collection in more detail. Other resources must be *reclaimed* and/or *recycled*.

When prototyping, you can generally assume that resources are unbounded, although it's good practice when you're using a resource to be aware of how much of the resource you're using and roughly what your budget for the resource is. For example:

- On a modern 32-bit desktop machine, 10,000 tuple values occupy only a small fragment of a machine's memory, roughly 160KB, but 10,000 open file handles is an extreme number and will stress the operating system. Ten thousand simultaneous web requests may stress your network administrator.

- In some cases, even memory should be explicitly and carefully reclaimed. For example, on a modern 64-bit machine, the largest single array you can allocate in a .NET 2.0 program is 2GB. If your machine has, say, 4GB of real memory, you may be able to have only a handful of these objects and should strongly consider moving to a regime in which you explicitly recycle these objects and think carefully before allocating them.

With the exception of stack and memory, all objects that own resources should be subtypes of the .NET type `System.IDisposable`. This is the primary way you can recognize primitive resources and objects that wrap resources. The `System.IDisposable` interface has a single method; in F# syntax, it can be defined as:

```
namespace System
    type IDisposable =
        abstract Dispose : unit -> unit
```

A simple approach to managing `IDisposable` objects is to give each resource a *lifetime*: that is, some well-defined portion of the program execution for which the object is active. This is even easier when the lifetime of a resource is lexically scoped, such as when a resource is allocated on entry to a function and deallocated on exit. In this case, the resource can be tied to the scope of a particular variable, and you can protect and dispose of a value that implements `IDisposable` by using a `use` binding instead of a `let` binding. For example, in the following code, three values implement `IDisposable`, all of which are bound using `use`:

```
/// Fetch a web page
let http (url : string) =
    let req = System.Net.WebRequest.Create url
    use resp = req.GetResponse()
    use stream = resp.GetResponseStream()
    use reader = new System.IO.StreamReader(stream)
    let html = reader.ReadToEnd()
    html
```

This is an improved version of the similar function you defined in Chapter 2, because it deterministically closes the network connections. In all three cases, the objects (a `WebResponse`, a `Stream`, and a `StreamReader`) are automatically closed and disposed at the end of an execution of the function.

A number of important types implement `IDisposable`; Table 6-1 shows some of them. You can use tables such as this to chart the portions of the .NET Framework that reveal operating system functionality to .NET applications.

*Table 6-1. A Selection of the Types That Implement `IDisposable`*

Namespace	Some Types Implementing <code>IDisposable</code>
<code>System.IO</code>	<code>BinaryReader</code> , <code>BinaryWriter</code> , <code>FileSystemWatcher</code> , <code>IsolatedFileStorage</code> , <code>Stream</code> , <code>TextReader</code> , <code>TextWriter</code> , ...
<code>System.Drawing</code>	<code>Brush</code> , <code>BufferedGraphics</code> , <code>Font</code> , <code>FontFamily</code> , <code>Graphics</code> , <code>Icon</code> , <code>Image</code> , <code>Pen</code> , <code>Region</code> , <code>TextureBrush</code> , ...
<code>System.Drawing.Text</code>	<code>FontCollection</code> , ...
<code>System.Drawing.Drawing2D</code>	<code>CustomLineCap</code> , <code>GraphicsPath</code> , <code>GraphicsPathIterator</code> , <code>Matrix</code> , ...
<code>System.Drawing.Imaging</code>	<code>EncoderParameter</code> , <code>ImageAttributes</code> , ...
<code>System.Net</code>	<code>WebResponse</code> , ...

System.Net.Sockets	Socket, TcpClient, ...
System.Data.SqlClient	SqlBulkCopy, SqlCommand, SqlConnection, SqlTransaction, ...
System.Threading	Timer, WaitHandle, AutoResetEvent, ManualResetEvent, Mutex, Semaphore, ...
System.Web.UI	Control, HttpApplication, ...
System.Web.UI.WebControls	Button, CheckBox, DataGrid, ...
System.Windows.Forms	Button, CheckBox, Cursor, Control, DataGrid, Form, ...
Microsoft.Win32	RegistryKey, ...

---

■ **Tip:** A tool such as Visual Studio can help you determine when a type has implemented `IDisposable`. When you rest your mouse pointer over a value, you usually see this noted on the information displayed for a value.

---

## WHEN WILL THE RUNTIME CLEAN UP FOR YOU?

---

People often ask if the .NET Common Language Runtime automatically cleans up resources such as file handles the same way it cleans up memory. While when an object gets garbage collected, it may be *finalized*, if the object is well implemented, this results in it deallocating any unmanaged resources, closing any outstanding file connections, and releasing any operating-system resources. Although it's appropriate to rely on finalization when prototyping, never rely on finalization in code where you're hitting resource limits.

For example, let's say you have a loop where you open files using `System.IO.File.OpenRead`. If you forget to close the file handles, you may quickly allocate thousands of them. If you're lucky, the garbage collector may finalize these before you run out of OS resources, but if not, one of your `File.OpenRead` calls will fail with an exception, even if the file exists on disk.

Also, be aware of the potential for memory stickiness. This occurs when the .NET Common Language Runtime is unable to garbage-collect memory even though objects have become unreachable. This happens especially when long-running computations and inactive callbacks hold on to object handles related to the earlier phases of execution of a program. Memory stickiness can also lead to objects never being finalized, reinforcing that you shouldn't rely on finalization to release nonmemory resources. Memory profiling tools such as CLRProfiler are indispensable when you're tracking down memory leaks in production code or long-running applications.

---

## Managing Resources with More Complex Lifetimes

Sometimes, the lifetime of a resource isn't simple in the sense that it doesn't follow a stack discipline. In these cases, you should almost always adopt one of two techniques:

- Design objects that can own one or more resources and that are responsible for cleaning them up. Make sure these objects implement `System.IDisposable`.
- Use control constructs that help you capture the kind of computation you're performing. For example, when generating sequences of data (such as from a database connection), you should strongly consider using sequence expressions, discussed in Chapter 3. These may have internal use bindings, and the resources are disposed when each sequence iteration finishes. Likewise, when using asynchronous I/O, it

may be helpful to write your computation as an asynchronous workflow. Chapter 11 and the following sections provide examples.

Consider implementing the `IDisposable` interface on objects and types in situations such as:

- When you build an object that uses one or more `IDisposable` objects internally.
- When you're writing a wrapper for an operating-system resource or some resource allocated and managed in a native (C or C++) DLL. In this case, implement a finalizer by overriding the `Object.Finalize` method.
- When you implement the `System.Collections.Generic.IEnumerable<T>` (that is, sequence) interface on a collection. The `IEnumerable` interface isn't `IDisposable`, but it must generate `System.Collections.Generic.IEnumerator<T>` values, and this interface inherits from `IDisposable`. For nearly all collection types, the disposal action returns without doing anything.

The following sections give some examples of these.

## Cleaning Up Internal Objects

Listing 6-6 shows an example that implements an object that reads lines from a pair of text files, choosing the file at random at each line pull. You must implement the type `IDisposable`, because the object owns two internal `System.IO.StreamReader` objects, which are `IDisposable`. You also must explicitly check to see whether the object has already been disposed.

*Listing 6-6. Implementing `IDisposable` to Clean Up Internal Objects*

```
open System.IO

type LineChooser(fileName1, fileName2) =
    let file1 = File.OpenText(fileName1)
    let file2 = File.OpenText(fileName2)
    let rnd = new System.Random()

    let mutable disposed = false

    let cleanup() =
        if not disposed then
            disposed <- true;
            file1.Dispose();
            file2.Dispose();

    interface System.IDisposable with
        member x.Dispose() = cleanup()

    member obj.CloseAll() = cleanup()

    member obj.GetLine() =
        if not file1.EndOfStream &&
            (file2.EndOfStream || rnd.Next() % 2 = 0) then file1.ReadLine()
        elif not file2.EndOfStream then file2.ReadLine()
        else raise (new EndOfStreamException())
```

You can now instantiate, use, and dispose of this object as follows:

---

```

> open System; open System.IO;;
> File.WriteAllLines("test1.txt", [|"Daisy, Daisy"; "Give me your hand oh do"|]);
> File.WriteAllLines("test2.txt", [|"I'm a little teapot"; "Short and stout"|]);
> let chooser = new LineChooser ("test1.txt", "test2.txt");

val chooser : LineChooser
> chooser.GetLine();;

val it : string = "Daisy, Daisy"
> chooser.GetLine();;

val it : string = "I'm a little teapot"
> (chooser :> IDisposable).Dispose();;
> chooser.GetLine();;

System.ObjectDisposedException: Cannot read from a closed TextReader.

```

---

Disposal should leave an object in an unusable state, as shown in the last line of the previous example. It's also common for objects to implement a member with a more intuitive name that does precisely the same thing as its implementation of `IDisposable.Dispose`, which is `CloseAll` in Listing 6-6.

## Cleaning Up Unmanaged Objects

If you're writing a component that explicitly wraps some kind of unmanaged resource, then implementing `IDisposable` is a little trickier. Listing 6-7 shows the pattern that is used for this cleanup. Here, you mimic an external resource via a data structure that generates fresh, reclaimable integer tickets. The idea is that each customer is given an integer ticket, but this is kept internal to the customer, and customers return their tickets to the pool when they leave (that is, are disposed).

### *Listing 6-7. Reclaiming Unmanaged Tickets with `IDisposable`*

```

open System

type TicketGenerator() =
    let mutable free = []
    let mutable max = 0
    member h.Alloc() =
        match free with
        | [] -> max <- max + 1; max
        | h :: t -> free <- t; h
    member h.Dealloc(n:int) =
        printfn "returning ticket %d" n
        free <- n :: free

let ticketGenerator = new TicketGenerator()

type Customer() =
    let myTicket = ticketGenerator.Alloc()

```

```

let mutable disposed = false
let cleanup() =
    if not disposed then
        disposed <- true
        ticketGenerator.Dealloc(myTicket)
member x.Ticket = myTicket
interface IDisposable with
    member x.Dispose() = cleanup(); GC.SuppressFinalize(x)
override x.Finalize() = cleanup()

```

Note that you override the `Object.Finalize` method. This makes sure cleanup occurs if the object isn't disposed but is still garbage-collected. If the object is explicitly disposed, you call `GC.SuppressFinalize()` to ensure that the object isn't later finalized. The finalizer shouldn't call the `Dispose()` of other managed objects, because they have their own finalizers if needed. The following example session generates some customers, and tickets used by some of the customers are automatically reclaimed as they exit their scopes:

---

```

> let bill = new Customer();;
val bill : Customer
> bill.Ticket;;
val it : int = 1
> begin
    use joe = new Customer()
    printfn "joe.Ticket = %d" joe.Ticket
end;;
joe.Ticket = 2
returning ticket 2
> begin
    use jane = new Customer()
    printfn "jane.Ticket = %d" jane.Ticket
end;;
jane.Ticket = 2
returning ticket 2

```

---

In the example, Joe and Jane get the same ticket. Joe's ticket is returned at the end of the scope where the `joe` variable is declared because of the `IDisposable` cleanup implicit in the use binding.

## Extending Existing Types and Modules

The final topic covered in this chapter is how you can define ad hoc dot-notation extensions to existing library types and modules. This technique is used rarely but can be invaluable in certain circumstances. For example, the following definition adds the member `IsPrime` to `Int32`.

```

module NumberTheoryExtensions =
    let isPrime i =
        let lim = int (sqrt (float i))

```



```
let rec check j =
    j > lim || (i % j <> 0 && check (j + 1))
check 2
```

```
type System.Int32 with
    member i.IsPrime = isPrime i
```

The `IsPrime` property is then available for use in conjunction with `int32` values whenever the `NumberTheoryExtensions` module has been opened. (Note, F# extension members are very similar to C# extension methods). For example:

---

```
> open NumberTheoryExtensions;;
> (2 + 1).IsPrime;;

val it : bool = true

> (6093700 + 11).IsPrime;;

val it : bool = false
```

---

Type extensions can be given in any assembly, but priority is always given to the intrinsic members of a type when resolving dot-notation.

Modules can also be extended in a fashion. For example, say you think the `List` module is missing an obvious function such as `List.pairwise` to return a new list of adjacent pairs. You can extend the set of values accessed by the path `List` by defining a new module `List`:

```
module List =
    let rec pairwise l =
        match l with
        | [] | [_] -> []
        | h1 :: ((h2 :: _) as t) -> (h1, h2) :: pairwise t
```

---

```
> List.pairwise [1; 2; 3; 4];;

val it : (int * int) list = [(1,2); (2,3); (3,4)]
```

---

■ **Note** Type extensions are a good technique for equipping simple type definitions with extra functionality. However, don't fall into the trap of adding too much functionality to an existing type via this route. Instead, it's often simpler to use additional modules and types. For example, the module `Microsoft.FSharp.Collections.List` contains extra functionality associated with the F# `list` type.

---

## USING MODULES AND TYPES TO ORGANIZE CODE

---

You often have to choose whether to use modules or object types to organize your code. Here are some of the rules for using these to organize your code effectively and to lay the groundwork for applying good .NET library and framework design principles to your code:

- Use modules when prototyping and to organize scripts, ad hoc algorithms, initialization code, and active patterns.
  - Use concrete types (records, discriminated unions, and class types) to implement concrete data structures. In the long term, plan on completely hiding the implementation of these types. You see how to do this in Chapter 7. You can provide dot-notation operations to help users access parts of the data structure. Avoid revealing other representation details.
  - Use object interface types for types that have several possible implementations.
  - Implement object interface types by private concrete types or by object expressions.
  - In polished libraries, most concrete types exposed in an implementation should also implement one or more object interface types. For example, collections should implement `IEnumerable<'T>`, and many types should implement `IDisposable`.
  - Avoid relying on or revealing complex type hierarchies. In particular, avoid relying on implementation inheritance, except as an internal implementation technique or when doing GUI programming or authoring very large objects.
  - Avoid nesting modules or types inside other modules or types. Nested modules and types are useful implementation details, but they're rarely made public in APIs. Deep hierarchical organization can be confusing; when you're designing a library, you should place nearly all public modules and types immediately inside a well-named namespace.
- 

## Working with F# Objects and .NET Types

This chapter has deemphasized the use of .NET terminology for object types, such as class and interface. However, all F# types are ultimately compiled as .NET types. Here is how they relate:

- Concrete types such as record types, discriminated unions, and class types are compiled as .NET classes.
- Object interface types are by default compiled as .NET interface types.

If you want, you can delimit class types using `class/end`:

```
type Vector2D(dx : float, dy : float) =
  class
    let len = sqrt(dx * dx + dy * dy)
    member v.DX = dx
    member v.DY = dy
    member v.Length = len
  end
```

or you can use a `Class` attribute:

```
[<Class>]
type Vector2D(dx : float, dy : float) =
  let len = sqrt(dx * dx + dy * dy)
  member v.DX = dx
```

```
member v.DY = dy
member v.Length = len
```

You see this in F# code samples on the Web and in other books. However, we have found that this tends to make types harder to understand, so we've omitted `class/end` and `Class` attributes throughout this book. You can also delimit object interface types by `interface/end`:

```
type IShape =
  interface
    abstract Contains : Point -> bool
    abstract BoundingBox : Rectangle
  end
```

or you can use an attribute:

```
[<Interface>]
type IShape =
  abstract Contains : Point -> bool
  abstract BoundingBox : Rectangle
```

Again, we omit these attributes in this book.

## Structs

It's occasionally useful to direct the F# compiler to use a .NET struct (value type) representation for small, generally immutable objects. You can do this by adding a `Struct` attribute to a class type and adding type annotations to all arguments of the primary constructor:

```
[<Struct>]
type Vector2DStruct(dx : float, dy : float) =
  member v.DX = dx
  member v.DY = dy
  member v.Length = sqrt (dx * dx + dy * dy)
```

Finally, you can also use a form that makes the values held in a struct explicit:

```
[<Struct>]
type Vector2DStructUsingExplicitVals =
  val dx : float
  val dy : float
  member v.DX = v.dx
  member v.DY = v.dy
  member v.Length = sqrt (v.dx * v.dx + v.dy * v.dy)
```

Structs are often more efficient, but you should use them with care because the full contents of struct values are frequently copied. The performance characteristics of structs can also change depending on whether you're running on a 32-bit or 64-bit machine.

## Delegates

Occasionally, you need to define a new .NET delegate type in F#:

```
type ControlEventHandler = delegate of int -> bool
```

This is usually required only when using C code from F#, because some magic performed by the .NET Common Language Runtime lets you marshal a delegate value as a C function pointer. Chapter 18 looks at interoperating with C and COM. For example, here's how you add a new handler to the Win32 Ctrl+C-handling API:

```
open System.Runtime.InteropServices
let ctrlSignal = ref false
[<DllImport("kernel32.dll")>]
extern void SetConsoleCtrlHandler(ControlEventHandler callback, bool add)

let ctrlEventHandler = new ControlEventHandler(fun i -> ctrlSignal := true; true)

SetConsoleCtrlHandler(ctrlEventHandler, true)
```

## Enums

Occasionally, you need to define a new .NET enum type in F#. You do this using a notation similar to discriminated unions:

```
type Vowels =
| A = 1
| E = 5
| I = 9
| O = 15
| U = 21
```

This type is compiled as a .NET enum whose underlying bit representation is a simple integer. Likewise, you can define enums for other .NET primitive types such as byte, int64 and uint64.

## Working with null Values

The keyword `null` is used in programming languages as a special, distinguished value of a type that represents an uninitialized value or some other kind of special condition. In general, `null` isn't used in conjunction with types defined in F# code, although it's common to simulate `null` with a value of the option type. For example:

---

```
> let parents = [("Adam", None); ("Cain", Some("Adam", "Eve"))];;
val parents : (string * (string * string) option) list = ...
```

---

Reference types defined in other .NET languages do support `null`, however; when using .NET APIs, you may have to explicitly pass `null` values to the API and also, where appropriate, test return values for `null`. The .NET Framework documentation specifies when `null` may be returned from an API. It's recommended that you test for this condition using `null` value tests. For example:

```
match System.Environment.GetEnvironmentVariable("PATH") with
| null -> printf "the environment variable PATH is not defined\n"
| res -> printf "the environment variable PATH is set to %s\n" res
```

The following is a function that incorporates a pattern match with type tests and a `null`-value test:

```

let switchOnType (a : obj) =
    match a with
    | null                -> printf "null!"
    | :? System.Exception as e -> printf "An exception: %s!" e.Message
    | :? System.Int32 as i   -> printf "An integer: %d!" i
    | :? System.DateTime as d -> printf "A date/time: %O!" d
    | _                    -> printf "Some other kind of object\n"

```

There are other important sources of null values. For example, the semisafe function `Array.zeroCreate` creates an array whose values are initially null or, in the case of value types, an array each of whose entries is the zero bit pattern. This function is included with F# primarily because there is no other technique for initializing and creating the array values used as building blocks of larger, more sophisticated data structures, such as queues and hash tables. Of course, you must use this function with care, and in general you should hide the array behind an encapsulation boundary and be sure the values of the array aren't referenced before they're initialized.

---

■ **Note:** Although F# generally enables you to code in a null-free style, F# isn't totally immune to the potential existence of null values: they can come from the .NET APIs, and it's also possible to use `Array.zeroCreate` and other back-door techniques to generate null values for F# types. If necessary, APIs can check for this condition by first converting F# values to the `obj` type by calling `box` and then testing for null (see the F# Informal Language Specification for full details). In practice, this isn't required by the vast majority of F# programs; for most purposes, the existence of null values can be ignored.

---

## Summary

This chapter looked at the basic constructs of object-oriented programming in F#, including concrete object types, object notation, and object interface types and their implementations, as well as more advanced techniques to implement object interface types. You also saw how implementation inheritance is less important as an object implementation technique in F# than in other object-oriented languages and then learned how the F# object model relates to the .NET object model. The next chapter covers language constructs and practical techniques related to encapsulating, packaging, and deploying your code.

## CHAPTER 7



# Encapsulating and Organizing Your Code

Organizing code and making it available for people and programs to use is a key part of making the best use of F#. In this book, you've already seen many of the constructs to help do this: functions, objects, type definitions, modules, namespaces, and assemblies. In some cases, however, you've encountered these only peripherally when using the libraries that come with F#. This chapter covers these constructs from the perspective of code organization and encapsulation.

Packaging code has four distinct but related meanings:

- *Organizing* code into sensible entities using namespaces, types, and modules.
- *Encapsulating* internal data structures and implementation details by making them private.
- *Assembling* code and data as one component, which for F# is called an *assembly*. An assembly is code packaged together with supporting resources as a single, logical unit of deployment.
- *Deploying* one or more assemblies, for example as a Web application or using a Web-based community packaging mechanism, such as NuGET.

The first two of these topics are associated with the F# language, and the last is more associated with the pragmatics of deploying, installing, configuring, and maintaining software. The third lies in between, because a .NET assembly can act as both a unit of encapsulation and a unit of deployment. In Chapter 19, we also consider some of the different kinds of software you may write with F# and how you can organize and package your code for these different cases.

## Hiding Things

In all kinds of software, it's common to hide implementation details of data structures and algorithms behind *encapsulation boundaries*. Encapsulation is a fundamental technique when writing software and is possibly the most important idea associated with object-oriented programming.

For this book's purposes, *encapsulation* means hiding implementation details behind well-defined boundaries. This lets you enforce consistency properties and makes the structure of a program easier to manage. It also lets an implementation evolve over time. A good rule of thumb is to hide anything you don't want used directly by client code.

Later, this chapter explains how encapsulation applies when you're building assemblies, frameworks, and applications. In the extreme, you may even be ensuring that your code is *secure* when used in partial trust mode—in other words, that it can't be inadvertently or deliberately used to achieve malicious results when used as a library by code that doesn't have full permissions. The most important kind of encapsulation, however, is the day-to-day business of hiding the internal implementation details of functions, objects, types, and modules. The primary techniques used to do this are:

- Local definitions
- Accessibility annotations
- Explicit signatures

We cover the first two of these techniques next, and we cover explicit signatures in “Hiding Things with Signatures” later in this chapter.

## Hiding Things with Local Definitions

The easiest way to hide definitions is to make them local to expressions or constructed class definitions using inner `let` bindings. These aren't directly accessible from outside their scope. This technique is frequently used to hide state and other computed values inside the implementations of functions and objects. Let's begin with a simple example. Here is the definition of a function that incorporates a single item of encapsulated state:

```
let generateTicket =
    let count = ref 0
    (fun () -> incr count; !count)
```

If you examine this definition, you see that the `generateTicket` function isn't defined immediately as a function; instead, it first declares a local element of state called *count* and then returns a function value that refers to this state. Each time the function value is called, `count` is incremented and dereferenced, but the reference cell is never published outside the function implementation, and it is thus encapsulated.

Encapsulation through local definitions is a particularly powerful technique in F# when used in conjunction with object expressions. For example, Listing 7-1 shows the definition of an object interface type called `IPeekPoke` and a function that implements objects of this type using an object expression.

### *Listing 7-1. Implementing Objects with Encapsulated State*

```
type IPeekPoke =
    abstract member Peek : unit -> int
    abstract member Poke : int -> unit

let makeCounter initialState =
    let state = ref initialState
    {new IPeekPoke with
        member x.Poke n = state := !state + n
        member x.Peek() = !state}
```

The type of the function `Counter` is:

---

```
val makeCounter : initialState:int -> IPeekPoke
```

---

As with the earlier `generateTicket` function, the internal state for each object generated by the `makeCounter` function is hidden and accessible only via the published `Peek` and `Poke` methods.

The previous examples show how to combine `let` bindings with anonymous functions and object expressions. You saw in Chapter 6 how `let` bindings can also be used in constructed class types. For example, Listing 7-2 shows a constructed class type with private mutable state `count` that publishes two methods: `Next` and `Reset`.

**Listing 7-2.** *A Type for Objects with Encapsulated State*

```
type TicketGenerator() =
  // Note: let bindings in a type definition are implicitly private to the object
  // being constructed. Members are implicitly public.
  let mutable count = 0

  member x.Next() =
    count <- count + 1;
    count

  member x.Reset () =
    count <- 0
```

The variable `count` is implicitly private to the object being constructed and is hence hidden from outside consumers. By default, other F# definitions are public, which means they're accessible throughout their scope.

Frequently, more than one item of state is hidden behind an encapsulation boundary. For example, the following code shows a function `makeAverager` that uses an object expression and two local elements of state, `count` and `total`, to implement an instance of the object interface type `IStatistic`:

```
type IStatistic<'T,'U> =
  abstract Record : 'T -> unit
  abstract Value : 'U

let makeAverager(toFloat: 'T -> float) =
  let count = ref 0
  let total = ref 0.0
  {new IStatistic<'T, float> with
    member stat.Record(x) = incr count; total := !total + toFloat x
    member stat.Value = (!total / float !count)}
```

The inferred types here are:

---

```
type IStatistic<'T,'U> =
  interface
    abstract member Record : 'T -> unit
    abstract member Value : 'U
  end
val makeAverager : toFloat:(('T -> float) -> IStatistic<'T,float>
```

---

The internal state is held in values `count` and `total` and is, once again, encapsulated.



---

■ **Note** Most of the examples of encapsulation in this chapter show ways to hide *mutable state* behind encapsulation boundaries. Encapsulation can be just as important for immutable constructs, however, especially in larger software components. For example, the implementation of the immutable `System.DateTime` type in the .NET BCL hides the way the date and time are stored internally but reveals the information via properties.

---

## Hiding Things with Accessibility Annotations

Local definitions are good for hiding most implementation details. Sometimes, however, you may need definitions that are local to a type, a module, or an assembly. You can change the default accessibility of an item by using an *accessibility annotation* to restrict the code locations that can use a construct. These indicate what is private or partially private to a module, file, or assembly. The primary accessibility annotations are `private`, `internal`, and `public`:

- `private` makes a construct private to the enclosing type definition/module.
- `internal` makes a construct private to the enclosing assembly (DLL or EXE).
- `public` makes a construct available globally, which is the default for most constructs.

Accessibility annotations are placed immediately prior to the name of the construct. Listing 7-3 shows how to protect an internal table of data in a module using accessibility annotations.

### Listing 7-3. Protecting a Table Using Accessibility Annotations

```
open System
```

```
module public VisitorCredentials =
```

```
    /// The internal table of permitted visitors and the
    /// days they are allowed to visit.
```

```
    let private visitorTable =
        dict [("Anna", set [DayOfWeek.Tuesday; DayOfWeek.Wednesday]);
             ("Carolyn", set [DayOfWeek.Friday])]
```

```
    /// This is the function to check if a person is a permitted visitor.
    /// Note: this is public and can be used by external code
```

```
    let public checkVisitor(person) =
        visitorTable.ContainsKey(person) &&
        visitorTable.[person].Contains(DateTime.Today.DayOfWeek)
```

```
    /// This is the function to return all known permitted visitors.
```

```
    /// Note: this is internal and can be used only by code in this assembly.
    let internal allKnownVisitors() =
        visitorTable.Keys
```

The private table is `visitorTable`. Attempting to access this value from another module gives a type-checking error. The function `checkVisitor` is marked `public` and is thus available globally. The function `allKnownVisitors` is available only within the same assembly (or the same F# Interactive session) as the

definition of the `VisitorCredentials` module. Note that you could drop the `public` annotations from function `checkVisitor` and module `VisitorCredentials`, because these declarations are public by default.

Accessibility annotations are often used to hide state or handles to resources such as files. In Listing 7-4, you protect a single reference cell containing a value that alternates between `Tick` and `tock`. This example uses an internal *event*, a technique covered in more detail in Chapter 11.

**Listing 7-4.** *Protecting Internal State Using Accessibility Annotations*

```
module public GlobalClock =

    type TickTock = Tick | Tock

    let mutable private clock = Tick

    let private tick = new Event<TickTock>()

    let internal oneTick() =
        (clock <- match clock with Tick -> Tock | Tock -> Tick);
        tick.Trigger (clock)

    let tickEvent = tick.Publish

module internal TickTockDriver =

    open System.Threading

    let timer = new Timer(callback=(fun _ -> GlobalClock.oneTick()),
                          state = null, dueTime = 0, period = 100)
```

In Listing 7-4, the private state is `clock`. The assembly-internal module `TickTockDriver` uses the `System.Threading.Timer` class to drive the alternation of the state via the internal function `oneTick`. The `GlobalClock` module publishes one `IEvent` value, `tickEvent`, which any client can use to add handlers to listen for the event. The sample uses the `Event` type, covered in more detail in Chapter 11.

Another assembly can now contain the following code, which adds a handler to `TickEvent`:

```
module TickTockListener =
    GlobalClock.tickEvent.Add(function
        | GlobalClock.Tick -> printfn "tick!"
        | GlobalClock.Tock -> printfn "tock!")
```

You can add accessibility annotations in a number of places in F# code:

- On `let`, and extern definitions in modules, and in individual identifiers in patterns
- On `new(...)` object constructor definitions
- On member definitions associated with types
- On module definitions
- On type definitions associated with types
- On primary constructors, such as `type C private (...) = ...`

---

■ **Note** You can add accessibility annotations to type abbreviations. The abbreviation, however, is still just an abbreviation—only the name, and not the actual equivalence, is hidden. That is, if you define a type abbreviation such as `type private label = int`, then all users of the type `label` know that it's really just an abbreviation for `int` and not a distinct type definition of its own. This is because .NET provides no way to hide type abbreviations; the F# compiler expands type abbreviations in the underlying generated .NET IL code.

---

Listing 7-5 shows a type in which some methods and properties are labeled `public` but the methods that mutate the underlying collection (`Add` and the set method associated with the `Item` property) are labeled `internal`.

*Listing 7-5. Making Property Setters Internal to a Type Definition*

```
open System.Collections.Generic

type public SparseVector () =

    let elems = new SortedDictionary<int, float>()

    member internal vec.Add (k, v) = elems.Add(k ,v)

    member public vec.Count = elems.Keys.Count
    member vec.Item
        with public get i =
            if elems.ContainsKey(i) then elems.[i]
            else 0.0
        and internal set i v =
            elems.[i] <- v
```

---

■ **Note** In class types, `let` bindings in types are always private to the object being constructed, and all member bindings default to `public`—they have the same accessibility as the type definition. This is a useful default, because it corresponds to the common situation in which internal implementation details are fully private and published constructs are available widely, and because omitting accessibility annotations makes code more readable in the common case.

---

## Organizing Code with Namespaces and Modules

The most important organizational technique for large-scale software is giving sensible qualified names to your types and values. A qualified name is, for example, `Microsoft.FSharp.Collections.List` (for the F# list type) or `System.IO.StreamReader` (for one of the types in the .NET Framework BCL). Qualified names are particularly important when you're writing frameworks to be used by other people, and they are also a useful way to organize your own code.

You give types and functions qualified names by placing them in namespaces, modules, and type definitions. Table 7-1 shows these three kinds of containers and what they can contain. For completeness,

the table includes type abbreviations, which are slightly different, because you can't use them as a container for other constructs.

*Table 7-1. Namespaces, modules, types, and what they can contain*

Entity	Description	Examples
Namespace	A namespace can contain further namespaces, modules, and types. Multiple DLLs can contribute to the same namespace.	<code>System</code> , <code>Microsoft.FSharp</code>
Module	A module can contain nested modules, types, and values.	<code>Microsoft.FSharp.Collections.Map</code> , <code>Microsoft.FSharp.Collections.List</code>
Concrete type definition	A type definition can contain members and nested type definitions.	<code>System.String</code> , <code>System.Int32</code>
Type abbreviation	A type abbreviation such as <code>string</code> , for <code>System.String</code> , can't act as a container for additional members, values, or types.	<code>int</code> , <code>string</code>

## Putting Your Code in a Module

One way to group items together with a common qualified name is to use a *module*. A module is a simple container for values, type definitions, and submodules. For example, here is the `Vector2D` example rewritten to use a module to hold the operations associated with the type:

```
type Vector2D =
    {DX : float; DY : float}

module Vector2Dops =
    let length v = sqrt (v.DX * v.DX + v.DY * v.DY)
    let scale k v = {DX = k * v.DX; DY = k * v.DY}
    let shiftX x v = {v with DX = v.DX + x}
    let shiftY y v = {v with DY = v.DY + y}
    let shiftXY (x, y) v = {DX = v.DX + x; DY = v.DY + y}
    let zero = {DX = 0.0; DY = 0.0}
    let constX dx = {DX = dx; DY = 0.0}
    let constY dy = {DX = 0.0; DY = dy}
```

Some people prefer to use classes with static members for this purpose, although modules tend to be more convenient for rapid prototyping. Modules may also contain type and submodule definitions.

## Putting Your Modules and Types in Namespaces

When designing a library, it is usually better to place your code in a *namespace*, which can contain only types and modules. Think of this as a restricted form of module, because it is forbidden to use `let` bindings outside of module or type definitions. Using namespaces forces you to adopt design- and code-organization patterns that are familiar to other `F#`, `C#`, and `.NET` programmers.

For example, Listing 7-6 shows a file that contains two type definitions, both located in the namespace `Acme.Widgets`.

*Listing 7-6. A File Containing Two Type Definitions in a Namespace*

```
namespace Acme.Widgets
    type Wheel = Square | Round | Triangle
    type Widget = {id : int; wheels : Wheel list; size : string}
```

Most significantly, namespaces are *open*, which means multiple source files and assemblies can contribute to the same namespace. For example, another implementation file or assembly can contain the definitions shown in Listing 7-7.

*Listing 7-7. A File Containing Two Type Definitions in Two Namespaces*

```
namespace Acme.Widgets
    type Lever = PlasticLever | WoodenLever

namespace Acme.Suppliers
    type LeverSupplier = {name : string; leverKind : Acme.Widgets.Lever}
```

The file in Listing 7-7 contributes to two namespaces: `Acme.Widgets` and `Acme.Suppliers`. The two files can occur in the same assembly or in different assemblies. Either way, when you reference the assembly (or assemblies), the namespace `Acme.Widgets` appears to have at least three type definitions (perhaps more, if other assemblies contribute further type definitions), and the namespace `Acme.Suppliers` has at least one.

## Hiding Things with Signatures

Every piece of F# code you write has a *signature type*. The inferred signature type for a piece of code is shown for every code fragment you enter into F# Interactive, and it can also be reported by using the F# command-line compiler, `fsc.exe`, with the `-i` option. For example, consider the following code, placed in an implementation file `clock.fs`:

```
module Clock

type TickTock = Tick | Tock

let ticker x =
    match x with
    | Tick -> Tock
    | Tock -> Tick
```

You can now invoke the command-line compiler from a command prompt:

---

```
C:\Users\dsyme\Desktop> fsc -i -a clock.fs
```

```
module Clock

type TickTock =
    | Tick
    | Tock

val ticker : x:TickTock -> TickTock
```

---

The inferred signature shows the results of type inference and takes into account other information, such as accessibility annotations.

If you want, you can make the inferred types explicit by using an *explicit signature type* for each implementation file. The syntax used for explicit signature types is identical to the inferred types reported by F# Interactive or `fsc.exe`, like those shown previously. If you use explicit signatures, they're placed in a *signature file*, and they list the names and types of all values and members that are accessible in some way to the outside world. Signature files should use the same root name as the matching implementation file with the extension `.fsi`. For example, Listing 7-8 shows the explicit signature file `vector.fsi` and the implementation file `vector.fs`.

**Listing 7-8.** A Signature File `vector.fsi` with Implementation File `vector.fs`

```
// The contents of vector.fsi
namespace Acme.Collections
    type SparseVector =
        new: unit -> SparseVector
        member Add : int * float -> unit
        member Item : int -> float with get

// The contents of vector.fs
namespace Acme.Collections
    open System.Collections.Generic
    type SparseVector() =
        let elems = new SortedDictionary<int, float>()
        member vec.Add(k, v) = elems.Add(k, v)
        member vec.Item
            with get i =
                if elems.ContainsKey(i) then elems.[i]
                else 0.0
        and set i v =
            elems.[i] <- v
```

You can now invoke the command-line compiler from a command-line shell:

---

```
C:\Users\dsyme\Desktop> fsc -a vector.fsi vector.fs
```

---

■ **Note** You can use signature types to hide constructs, which can be used as an alternative to giving accessibility annotations on types, values, and members. Neither accessibility annotations nor signatures can hide type abbreviations, for the reasons discussed earlier in “Hiding Things with Accessibility Annotations.” Some additional restrictions apply to both hiding techniques. For example, if a type is revealed to be a constructed class type or interface type, all of its abstract members must be included in the signature. Similarly, a record type must reveal all of its fields, and a discriminated union type must reveal all of its cases. Also, in some languages, such as OCaml, a signature may restrict the type of an implementation construct. For example, if a function is inferred to have a generic type `'a -> 'a`, then in OCaml, the signature may specify a more restricted type, such as `int -> int`. This isn't permitted in F#.

---

## Designing with Signatures

Although explicit signature types are optional, many programmers like to use them, especially when writing a library framework, because the signature file gives a place to document and maintain a component's public interface. For example, a signature file can be used to contain the “public facing” API and documentation for a library, while the implementation contains the implementation.

Using explicit signature types comes with a cost: the signature files duplicate names, documentation, attributes, and some other information found in the implementation.

## When Are Signature Types Checked?

A signature file appears *before* the implementation file in the compilation order for the files in an F# program. The conformance between the signature type and the corresponding implementation is checked *after* an implementation has been fully processed, however. This is unlike type annotations that occur directly in an implementation file, which are applied *before* an implementation fragment is processed. This means that the type information in a signature file isn't used as part of the type-inference process when processing the implementation.

---

■ **Note** Each signature file must appear before its corresponding implementation file in the compilation order in an F# project. In Visual Studio, this means that the signature file must come before the implementation file in the project listing.

---

## Defining a Module with the Same Name as a Type

Sometimes it is useful to have a module with the same name as one of your types. You can do this by adding an attribute to your code:

```
type Vector2D =
    {DX : float; DY : float}

[<CompilationRepresentation(CompilationRepresentationFlags.ModuleSuffix)>]
module Vector2D =
    let length v = sqrt(v.DX * v.DX + v.DY * v.DY)
```

## Preventing Client Code from Opening a Module

Values in a module can be used via a long path, such as `Vector2D.length`. Alternatively, you can open the module, which makes all the contents accessible without qualification. For example, `open Vector2D` makes the identifier `length` available without qualification.

Modules, however, are often designed in such a way that client code should not normally “open” the module, because doing so will create too many ambiguities among various function and value names. Allowing clients to open your modules may make client code more brittle as you add new functions to your modules. For this reason, you can add an attribute `RequireQualifiedAccess` indicating that qualified access to the module or type is required:

```
[<RequireQualifiedAccess>]
module Vector2D =
    let length v = sqrt(v.DX * v.DX + v.DY * v.DY)
    let zero = {DX=0.0; DY=0.0}
```

The following code then gives an error:

---

```
> open Vector2D;;
```

```
error FS0892: This declaration opens the module 'FSI_0003.Vector2D', which is marked as
'RequireQualifiedAccess'. Adjust your code to use qualified references to the elements of the
module instead, e.g. 'List.map' instead of 'map'. This change will ensure that your code is
robust as new constructs are added to libraries.
```

---

## Using Files as Modules

In F#, a module is a simple container for values and type definitions. Modules also often are used to provide outer structure for fragments of F# code; many of the simple F# programs you've seen so far in this book have been in modules without your knowing about them. In particular:

- Code fragments typed into F# Interactive and delimited by `;;` are each implicitly placed in a module of their own.
- Files compiled with the command-line compiler using Visual Studio or loaded into F# Interactive with `#Load` have their values and types placed in a namespace or module according to the leading module or namespace declaration in the file. Declarations in files without a leading module or namespace declaration are placed in a module whose name is derived from the name of the implementation file.

Let's look at the second case in more detail. You can explicitly declare the name of the namespace/module for a file by using a leading module declaration. For example, Listing 7-9 defines the module `Acme.Widgets.WidgetWheels`, regardless of the name of the file containing the constructs.

### *Listing 7-9. An Implementation Module With an Explicit Initial Module Declaration*

```
module Acme.Widgets.WidgetWheels

type Wheel = Square | Triangle | Round

let wheelCornerCount =
    dict [(Wheel.Square, 4)
         (Wheel.Triangle, 3)
         (Wheel.Round, 0)]
```

Here, the first line gives the name for the module defined by the file. The namespace is `Acme.Widgets`, the module name is `WidgetWheels`, and the full path to the value is `Acme.Widgets.WidgetWheels.wheelCornerCount`.



## Automatically Opening Modules

Modules can be labeled `AutoOpen`, meaning they're treated as opened whenever the enclosing namespace or module is opened. This can be useful when you're defining ad hoc top-level operators and functions:

```
namespace Acme.Compenents

[<AutoOpen>]
module private Utilities =
    let swap (x,y) = (y,x)

// Note, the module is not explicitly opened, but 'swap' is accessible throughout the file
swap (3,4)
```

This mechanism can also be useful when designing libraries and frameworks, especially for modules holding extension members and functions. For example:

```
namespace Acme.NumberTheory

[<AutoOpen>]
module NumberTheoryExtensions =
    let private isPrime i =
        let lim = int (sqrt (float i))
        let rec check j =
            j > lim || (i % j <> 0 && check (j+1))
        check 2

    type System.Int32 with
        member i.IsPrime = isPrime i
```

In this example, the `IsPrime` extension property is automatically available as soon as the path `Acme.NumberTheory` is opened. There is then no need to open the specific extension module directly—you can simply open the enclosing namespace.

You can also attach an `AutoOpen` attribute to an assembly, with a string path. This means the path is opened as soon as the assembly is referenced, in the order in which the assemblies are given to the F# command-line compiler:

```
[<assembly:AutoOpen("Acme.NumberTheory")>]
do()
```

The path can be to a namespace or to a module. This last mechanism should be used rarely and diligently. It is most useful when writing a framework that configures F# as a scripting environment for a specific programming domain, because referencing an assembly can then automatically add various modules, types, functions, and extension members into the environment of the consuming code, without requiring “open” declarations in client code.

## Reusing Your Code

This book has used F# Interactive for most of the samples. F# Interactive is excellent when you're exploring a set of libraries and writing scripts or small applications that use them. As your F# programming progresses,

however, you will need to venture beyond these small scripts and start to write libraries and components that are reused across multiple projects and scripts.

## Using Files as Small Reusable Components

One of the simplest kinds of reusable components in F# is the “single standalone F# file with optional signature,” which we’ll call a *single file component*. We’ve seen examples of these earlier in this chapter, for example in Listing 7-8, showing implementation-file `vector.fs` and signature-file `vector.fsi`.

A single file component can be included in multiple assemblies simply by referencing the common file in multiple compilations. In Visual Studio, you can link to a single file from multiple projects—for example, using “Add Existing File” © “Add as Link” and using Alt-Up and Alt-Down to move the file(s) to the right place in the compilation order for the project.

A single file component can be referenced from an F# Interactive script using `#load`, e.g.,

```
#load "vector.fs"
```

In F#, a single file may sometimes contain a very large amount of functionality, especially if accompanied by a signature file. If a single file component has a signature file, you can also refer to that in the `#load` directive, e.g.,

```
#load "vector.fsi" "vector.fs"
```

A single file component may not list its dependencies in terms of other components or assemblies. This means the project that hosts the single file must list the dependencies in its references. For use from F# Interactive, however, you can place the dependencies in an accompanying script file that contains the necessary `#r` directives. For example, if you are using an F# wrapper for a charting library, and the wrapper is in `charting.fs` and `charting.fsi`, then it can be useful to also create a `charting.fsx` containing any necessary `#r` directives.

```
#load "charting.fsi" "charting.fs" "charting.fsx"
```

The `#load` directive for F# Interactive is not limited to a single file—you can include multiple signature files and implementation files in a single directive. For example:

```
#load "matrix.fsi" "matrix.fs" "vector.fsi" "vector.fs"
```

Again, the `#load` is only used in F# Interactive and is not valid in `.fs` or `.fsi` files.

## Creating Assemblies, DLLs, and EXEs

F# Interactive is excellent when you’re exploring a set of libraries and writing scripts or small applications that use them. But to understand how to write libraries and organize other kinds of applications, you need to learn how to use the F# command-line compiler, `fsc.exe`, to compile your code into DLLs and EXEs. A Dynamic Link Library (DLL) is a name for library components, and `.exe` is the extension used for executable programs.

As you saw at the start of this chapter, all .NET code compiled to IL exists in an *assembly*, which is, roughly speaking, either a DLL or an EXE. Assemblies can also contain supporting code and data files. Every time you compile a set of files using `fsc.exe`, you create one assembly, either a DLL or an EXE. Even when you use F# Interactive (`fsi.exe`), you’re dynamically adding code to a dynamically generated assembly. You will now learn how to use the command-line compiler to create assemblies.

To compile code to an EXE, you call `fsc.exe` with the names of your source-code files in dependency order. For example, if the file `dolphin.fs` contains the code in Listing 7-10, then you can compile the code using `fsc dolphin.fs`. You can also use the `-o` flag to name the generated EXE.

**Listing 7-10.** *File dolphins.fs*

```
let longBeaked = "Delphinus capensis"
let shortBeaked = "Delphinus delphis"
let dolphins = [longBeaked; shortBeaked]
printfn "Known Dolphins: %A" dolphins
```

You can now compile this code to an EXE:

---

```
C:\fsharp> fsc dolphins.fs
C:\fsharp> dir dolphins.exe
```

```
...
18/06/2012 02:30 p.m.          4,608 dolphin.exe
```

```
C:\fsharp> dolphins.exe
```

```
Known Dolphins: ["Delphinus capensis"; "Delphinus delphis"]
```

---

To compile F# code into a DLL, take one or more source files and invoke `fsc.exe` with the `-a` option. For example, let's assume the file `whales.fs` contains the code shown in Listing 7-11. (This sample also includes some documentation comments, referred to in the “Generating Documentation” section later in this chapter.)

**Listing 7-11.** *File whales.fs*

```
module Whales.Fictional

/// The three kinds of whales we cover in this release
type WhaleKind =
    | Blue
    | Killer
    | GreatWhale

/// The main whale
let moby = "Moby Dick, Pacific", GreatWhale

/// The backup whale
let bluey = "Blue, Southern Ocean", Blue

/// This whale is for experimental use only
let orca = "Orca, Pacific", Killer

/// The collected whales
let whales = [|moby; bluey; orca|]
```

You can now compile the code as follows:

```
C:\test> fsc -g -a whales.fs
C:\test> dir whales.dll
```

```
...
18/06/2012 02:37 p.m.          9,216 whales.dll
```

Here you've added one command-line flag: `-g` to generate debug output. When compiling other assemblies, you need to reference your DLLs. For example, consider the code in Listing 7-12, which needs to reference `whales.dll`.

**Listing 7-12.** *File whalewatcher.fs*

```
open Whales
open System

let idx = Int32.Parse(Environment.CommandLineArgs().[1])
let spotted = Fictional.whales.[idx]

printfn "You spotted %A!" spotted
```

You can compile this file by adding an `-r` flag to reference the DLLs on which the code depends. You can also use the `-o` flag to name the generated EXE or DLL and the `-I` flag to list search paths:

---

```
C:\fsharp> fsc -g -r whales.dll -o watcher.exe whaleWatcher.fs
C:\fsharp> dir watcher.exe
```

```
...
18/06/2012 02:48 p.m.          5,120 watcher.exe
C:\fsharp> watcher.exe 1
```

```
You spotted ("Blue, Southern Ocean", Blue)!
```

---

■ **Note** F# assemblies often contain a large amount of code. For example, a single assembly may contain the compiled output from as many as 30 to 50 F# source-code files. Having many small assemblies may seem tempting, but it can lead to difficulties when you're managing updates, and it can be confusing to end users. Large assemblies are easier to version: you have to update only one component, and you can package multiple updates into a single new version of the DLL.

---

## Creating and Sharing Packages

Once you have organized your code into files and assemblies, you may wish to make these available to a wider audience using a packaging and sharing mechanism. Sharing is at the heart of modern communities. Some alternatives for packaging your code for reuse and sharing are:

- *NuGET*. At the time of writing, one of the most popular package sharing mechanisms for F# and .NET code is NuGET, see [www.nuget.org](http://www.nuget.org).
- *Open Source Snippet Sites*. Place your code on a snippet site, such as [www.fsnip.net](http://www.fsnip.net) and [www.tryfsharp.org](http://www.tryfsharp.org).
- *Open Source Forges*. Make your code a project on a forge site, such as [www.github.com](http://www.github.com) or [www.codeplex.com](http://www.codeplex.com).

- *Blogs and Web Sites.* Make a ZIP of your code available on the Web.
- *Installers.* Package your code as an installer that installs local copies of components on a target machine in known locations.
- *Network Drives.* If using an intranet, place a copy of your code on a mounted network drive.

## Summary

In this chapter, you learned about a number of techniques related to encapsulating and organizing your code, from the language mechanisms used for accessibility, encapsulation, modules, namespaces, and signatures to building assemblies and the related topics of building applications and DLLs.

The next three chapters look at some of the techniques you need to master to work with different kinds of data as you progress with learning to program in F#.

## CHAPTER 8



# Working with Textual Data

Chapters 2 and 3 introduced the F# type for strings. While F#'s specialty is in programming with structured data, unstructured or semi-structured textual data are exceptionally common in programming, both as a data format and as working representation internally in algorithms that work over documents and text. In this section, you will learn some of the techniques available for working with textual data in F# programs, including working with the XML and JSON structured data formats, which are initially represented as text.

## Building Strings and Formatting Data

In Chapter 3, you saw the different forms of string literals (strings with escape characters and verbatim strings) and the most typical operations, such as concatenation using string builders. You may also remember that string values are *immutable* and that string operations that seem to change their input actually return a new string that represents the result. The following sections cover further ways to work with strings.

### Building Strings

In Chapter 3, you saw how the + operator is one simple tool for building strings, and you saw a number of simple string literals. You can also build strings using objects of the type `System.Text.StringBuilder`. These objects are mutable buffers that you can use to accumulate and modify text, and they're more efficient than repeated uses of the + operator. Here's an example:

---

```
> let buf = new System.Text.StringBuilder();  
  
val buf : System.Text.StringBuilder  
  
> buf.Append("Humpty Dumpty");  
  
> buf.Append(" sat on the wall");  
  
> buf.ToString();  
  
val it : string = "Humpty Dumpty sat on the wall"
```

---

## More about String Literals

The F# type `string` is an abbreviation for the type `System.String` and represents a sequence of Unicode UTF-16 characters. The following sections briefly introduce strings and the most useful functions for formatting them. Table 8-1 shows the different forms for writing string literals.

*Table 8-1. String and Character Literals*

Example	Kind	Type
"Humpty Dumpty"	String	<code>string</code>
"c:\\Program Files"	String	<code>string</code>
@"c:\\Program Files"	Verbatim string	<code>string</code>
""I "like" you""	Triple quote string	<code>string</code>
"xyZy3d2"B	Literal byte array	<code>byte []</code>
'c'	Character	<code>char</code>

As shown in Table 8-1, a literal form is also available for arrays of bytes: the characters are interpreted as ASCII characters, and non-ASCII characters can be embedded using escape codes. This can be useful when you're working with binary protocols. Verbatim string literals are particularly useful for file and path names that contain the backslash character (`\`):

---

```
> "MAGIC"B;;

val it : byte [] = [|77uy; 65uy; 71uy; 73uy; 67uy|]

> let dir = @"c:\Program Files";

val dir : string = "c:\Program Files"

> let text = ""I "like" you"";

val text : string = "I "like" you"
```

---

Triple-quote string literals can contain both embedded quotation marks (`"`) and backslashes (`\`) without escape, and include all the text until the terminating triple quote. You can also use multiline string literals:

---

```
> let s = "All the kings horses
- and all the kings men";

val s : string = " All the kings horses
and all the kings men"

> let s2 = ""All the kings' "horses"
- and all the kings men"";

val s2 : string = "All the kings' "horses"
- and all the kings men"
```

---

Table 8-2 shows the escape characters you can use in strings and characters.

**Table 8-2.** *Escape Characters in Nonverbatim Strings*

Escape	Character	ASCII/Unicode Value	Examples
\n	New line	10	"\n"
\r	Carriage return	13	"\r"
\t	Tab	9	"\t"
\b	Backspace	8	"a\b" ("a")
\NNN	Trigraph	NNN	"\032" ( <i>space</i> )
\uNNNN	Unicode character	NNNN	"\u00a9" (©)
\UNNNNNNNN	Long Unicode character	NNNN NNNN	"\U00002260" ( )

## Using printf and Friends

Throughout this book, you've used the `printfn` function, which is one way to print strings from F# values. This is a powerful, extensible technique for type-safe formatting. A related function called `sprintf` builds strings:

```
> sprintf "Name: %s, Age: %d" "Anna" 3;;
val it : string = "Name: Anna, Age: 3"
```

The format strings accepted by `printf` and `sprintf` are recognized and parsed by the F# compiler, and their use is statically type checked to ensure that the arguments given for the formatting holes are consistent with the formatting directives. For example, if you use an integer where a string is expected, you see a type error:

```
> sprintf "Name: %s, Age: %d" 3 10;;
error FS0001: This expression was expected to have type
    string
but here has type
    int
```

Several `printf`-style formatting functions are provided in the `Microsoft.FSharp.Text.Printf` module. Table 8-3 shows the most important of these.

**Table 8-3.** *Formatting Functions in the printf Module*

Function(s)	Outputs via Type	Outputs via Object	Example
<code>printf(n)</code> <sup>a</sup>	<code>TextWriter</code>	<code>Console.Out</code>	<code>printf "Result: %d" res</code>
<code>eprintf(n)</code>	<code>TextWriter</code>	<code>Console.Error</code>	<code>eprintf "Result: %d" res</code>
<code>fprintf(n)</code>	<code>TextWriter</code>	Any <code>TextWriter</code>	<code>fprintf stderr "Error: %d" res</code>
<code>sprintf</code>	<code>string</code>	Generates strings	<code>sprintf "Error: %d" res</code>
<code>bprintf(n)</code>	<code>StringBuilder</code>	Any <code>StringBuilder</code>	<code>bprintf buf "Error: %d" res</code>

<sup>a</sup> The functions with a suffix *n* add a new line to the generated text.



Table 8-4 shows the basic formatting codes for printf-style formatting.

**Table 8-4.** Formatting Codes for printf-style String and Output Formatting

Code	Type Accepted	Notes
%b	bool	Prints true or false
%s	string	Prints the string
%d, %u, %x, %X, %o	int/int32	Signed and unsigned decimal whole numbers, hex in lower and upper case, and octal formats for any integer types
%e, %E, %f, %g	float	Floating-point formats
%M	decimal	See the .NET documentation
%A	Any type	Uses structured formatting, discussed in the section “Generic Structural Formatting” and in Chapter 5
%+A	Any type	Uses structured formatting, but accesses to private internals of data structures if they are accessible via reflection
%O	Any type	Uses <code>Object.ToString()</code>
%a	Any type	Takes two arguments: one is a formatting function, and one is the value to format
%t	Function	Runs the function given as an argument

Any value can be formatted using a %O or %A pattern; these patterns are extremely useful when you're prototyping or examining data. %O converts the object to a string using the `Object.ToString()` function supported by all values. For example:

```
// The formatting of dates and times varies by region.
> System.DateTime.Now.ToString();

val it : string = "28/06/20.. 17:14:07 PM"

> sprintf "It is now %O" System.DateTime.Now;;

val it : string = "It is now 28/06/20... 17:14:09"
```

■ **Note** The format strings used with printf are scanned by the F# compiler during type checking, which means the use of the formats are type safe; if you forget arguments, a warning is given, and if your arguments are of the wrong type, an error is given. The format strings may also include the usual range of specifiers for padding and alignment used by languages such as C, as well as some other interesting specifiers for computed widths and precisions. You can find the full details in the F# library documentation for the `Printf` module.

## Generic Structural Formatting

`Object.ToString()` is a somewhat undirected way of formatting data. Structural types—such as tuples, lists, records, discriminated unions, collections, arrays, and matrices—are often poorly formatted by this technique. The `%A` pattern uses .NET reflection to format any F# value as a string based on the structure of the value. For example:

---

```
> printf "The result is %A\n" [1; 2; 3];;
```

```
The result is [1; 2; 3]
```

---

Generic structural formatting can be extended to work with any user-defined data types, a topic covered on the F# Web site. This is covered in detail in the F# library documentation for the `printf` function.

## Formatting Strings Using .NET Formatting

Throughout this book, you've used F# `printf` format strings to format text and output; Chapter 4 and the section above introduced the basic format specifiers for this kind of text formatting. Functions such as `printf` and `printfn` are located in the `Microsoft.FSharp.Text.Printf` module.

Another way to format strings is to use the `System.String.Format` static method or the other .NET composite formatting functions, such as `System.Console.WriteLine` and `TextWriter.WriteLine`. This is a distinct set of formatting functions and directives redesigned and implemented from the ground up for the .NET platform. Like `printf`, these methods take a format specifier and the objects to be formatted. The format specifier is a string with any number of format items acting as placeholders and designating which object is to be formatted and how. Consider this simple example:

---

```
> System.String.Format("{0} {1} {2}", 12, "a", 1.23);;
```

```
val it : string = "12 a 1.23"
```

---

Each format item is enclosed in braces giving the index of the object to be formatted, and each can include an optional alignment specification (always preceded by a comma after the index, giving the width of the region in which the object is to be inserted, as in `{0, 10}`) and a format type that guides how the given object is formatted (as in `{0:C}`, where `C` formats as a system currency). The general syntax of the format item is:

```
{index[,alignment][:formatType]}
```

You can use the alignment value to pad the formatted object with spaces; text alignment is left if its value is negative and right if positive. Table 8-5 summarizes the most-often-used format types.

**Table 8-5.** *The .NET Format Specifiers*

Specifier	Type
C	Currency
D	Decimal/long date
E	Scientific
F	Fixed-point
G	General
N	Number
P	Percent
X	Hexadecimal
d/D	Short/long date
t/T	Short/long time
M	Month
Y	Year

You can find more information about .NET composite formatting at [www.expert-fsharp.com/Topics/TextFormatting](http://www.expert-fsharp.com/Topics/TextFormatting).

## Parsing Strings and Textual Data

### Parsing Basic Values

The following session shows some sample uses of the `DateTime` type:

---

```
> open System;;
> DateTime.Parse("13 July 1968");;

val it : DateTime = 13/07/1968 00:00:00

> let date x = DateTime.Parse(x);;

val date : x:string -> DateTime

> printfn "date = %A" (date "13 July 1968");;

date = 13/07/1968 00:00:00

> printfn "birth = %A" (date "18 March 2003, 6:21:01pm");;

birth = 18/03/2003 18:21:01
```

---

Note that formatting dates depends on the user's localization settings; you can achieve more explicit formatting by using the `System.DateTime.ToString` overload that accepts explicit format information.

Here you use the `System.Uri` type to parse a URL:

---

```
> open System;;

> Uri.TryCreate("http://www.thebritishmuseum.ac.uk/", UriKind.Absolute);;

val it : bool * Uri =
  (true,
   http://www.thebritishmuseum.ac.uk/)
> Uri.TryCreate("e3f%/ww.gibberish.com", UriKind.Absolute);;

val it : bool * Uri = (false, null)
```

---

## Processing Line-Based Input

A common, simple case of parsing and lexing occurs when you're working with an existing line-based, text-file format. In this case, parsing is often as easy as splitting each line of input at a particular separator character and trimming whitespace off the resulting partial strings:

---

```
> let line = "Smith, John, 20 January 1986, Software Developer";;

val line : string = "Smith, John, 20 January 1986, Software Developer"

> line.Split ',';;

val it : string [] = [|"Smith"; " John"; " 20 January 1986"; " Software Developer"|]

> line.Split ',' |> Array.map (fun s -> s.Trim());;

val it : string [] = [|"Smith"; "John"; "20 January 1986"; "Software Developer"|]
```

---

You can then process each column in the data format:

```
let splitLine (line : string) =
  line.Split [|','|] |> Array.map (fun s -> s.Trim())

let parseEmployee (line : string) =
  match splitLine line with
  | [|last; first; startDate; title|] ->
    last, first, System.DateTime.Parse(startDate), title
  | _ ->
    failwithf "invalid employee format: '%s'" line
```

The type of this function is:

---

```
val parseEmployee : line:string -> string * string * DateTime * string
```

---

Here is an example use:

---

```
> parseEmployee line;;

val it : string * string * DateTime * string
      = ("Smith", "John", 20/01/1986 00:00:00 { ... }, "Software Developer")
```

---

You can now use on-demand reading of files to turn a file into an on-demand sequence of results. The following example takes the first three entries from an artificially generated file containing 10,000 copies of the same employee, sets up a processing pipeline for the lines of the file, and then truncates that to the first three elements.

```
open System.IO

File.WriteAllLines("employees.txt", Array.create 10000 line)

let readEmployees (fileName : string) =
    fileName |> File.ReadLines |> Seq.map parseEmployee

let firstThree = readEmployees "employees.txt" |> Seq.truncate 3 |> Seq.toList

> firstThree |> Seq.iter (fun (last, first, startDate, title) ->
    printfn "%s %s started on %A" first last startDate);;
```

---

```
John Smith started on 20/01/1986 00:00:00
John Smith started on 20/01/1986 00:00:00
John Smith started on 20/01/1986 00:00:00
```

---

This technique often is used to do exploratory analysis of large data files. After the algorithm is refined using a prefix of the data, the analysis can then be run directly over the full data file by removing the `Seq.truncate 3` step.

## Using Regular Expressions to Parse Lines

Another technique that's frequently used to extract information from strings is to use regular expressions. The `System.Text.RegularExpressions` namespace provides convenient string-matching and -replacement functions. For example, let's say you have a log file containing a record of HTML GET requests. Here is a sample request:

```
GET /favicon.ico HTTP/1.1
```

The following code captures the name of the requested resource (`favicon.ico`) and the lower version number of the HTML protocol (1) used:

```
open System.Text.RegularExpressions

let parseHttpRequest line =
    let result = Regex.Match(line, @"GET (.*) HTTP/1\.[01]$")
    let file = result.Groups.[1].Value
    let version = result.Groups.[2].Value
    file, version
```

The relevant fields are extracted by using the `Groups` attribute of the regular expression match to access the matched strings for each parenthesized group in the regular expression.

## More on Matching with `System.Text.RegularExpressions`

One of the most popular ways of working with strings as data is through the use of *regular expressions*. You do this using the functionality from the `.NET System.Text.RegularExpressions` namespace. To get started, first note that the F# library includes the following definition:

```
open System.Text.RegularExpressions
let regex s = new Regex(s)
```

To this, you can add the following Perl-like operators:

```
let (=~) s (re:Regex) = re.IsMatch(s)
let (<>~) s (re:Regex) = not (s =~ re)
```

Here, the inferred types are:

---

```
val regex : s:string -> Regex
val ( =~ ) : s:string -> re:Regex -> bool
val ( <>~ ) : s:string -> re:Regex -> bool
```

---

The infix operators allow you to test for matches:

---

```
> let samplestring = "This is a string";;
val samplestring : string = "This is a string"
> if samplestring =~ regex "his" then
    printfn "A Match! ";;
A Match!
```

---

Regular expressions can include `*`, `+`, and `?` symbols for zero or more occurrences, one or more occurrences, and zero or one occurrences of the immediately preceding regular expression, respectively, and they can include parentheses to group regular expressions. For example:

---

```
> "This is a string" =~ regex "(is )+";;
val it : bool = true
```

---

Regular expressions also can be used to split strings:

---

```
> regex(" ").Split("This is a string");;
val it : string [] = [|"This"; "is"; "a"; "string"|]
```

---

Here, you use the regular expression " " for whitespace. In reality, you probably want to use the regular expression " +" to match multiple spaces. Better still, you can match any Unicode whitespace character using \s, including end-of-line markers. When using escape characters, however, you should use verbatim strings to specify the regular expression, such as @" \s+". Let's try:

---

```
> regex(@"\s+").Split("I'm a little      teapot");;
val it : string [] = [|"I'm"; "a"; "little"; "teapot"|]
> regex(@"\s+").Split("I'm a little \t\t\n\t\n\t teapot");;
val it : string [] = [|"I'm"; "a"; "little"; "teapot"|]
```

---

Here's how to match by using the method Match instead of using =~ and IsMatch. This lets you examine the positions of a match:

---

```
> let m = regex("joe").Match("maryjoewashere");;
val m : Match = joe
> if m.Success then
    printfn "Matched at position %d" m.Index;;
```

*Matched at position 4*

---

Replacing text is also easy:

---

```
> let text = "was a dark and stormy night";;
val text : string = "was a dark and stormy night"
> let t2 = regex(@"\w+").Replace(text, "WORD");;
val t2: string = "WORD WORD WORD WORD WORD WORD"
```

---

Here, you use the regular expression "\w+" for a sequence of word characters.

Table 8-6 shows the broad range of specifiers you can use with .NET regular expressions.

**Table 8-6.** Regular Expression Escape Characters

Characters	Description
Ordinary characters	Characters other than . \$ ^ { [ (   ) * + ? \ match themselves.
.	Matches any character except \n. If RegexOptions.SingleLine is specified, it matches every character.
[aeiou0-9]	Matches any of the given characters or character ranges.
[^aeiou0-9]	Matches any character other than the given characters or character ranges.
\p{name}	Matches any character in the named character class specified by {name}. See the .NET documentation for full details.

Characters	Description
\P{name}	Matches text not included in groups and block ranges specified in {name}.
\w	Matches any word character.
\W	Matches any nonword character.
\s	Matches any whitespace character.
\S	Matches any nonwhitespace character.
Characters	Description
\d	Matches any decimal digit.
\D	Matches any nondigit.
\a	Matches a bell (alarm) \u0007.
\b	Matches a backspace \u0008 if in a [] character class; otherwise, in a regular expression, \b denotes a word boundary (between \w and \W characters). In a replacement pattern, \b always denotes a backspace.
\t	Matches a tab \u0009.
\r	Matches a carriage return \u000D.
\v	Matches a vertical tab \u000B.
\f	Matches a form feed \u000C.
\n	Matches a new line \u000A.
\e	Matches an escape \u001B.
\digit	Matches a back reference.
\040	Matches an ASCII character as octal.
\x20	Matches an ASCII character using hexadecimal representation (exactly two digits).
\cC	Matches an ASCII control character; for example, \cC is Ctrl+C.
\u0020	Matches a Unicode character using hexadecimal representation (exactly four digits).
\	When followed by a character that isn't recognized as an escaped character, matches that character. For example, \* is the same as \x2A.

You can specify case-insensitive matches by using (?i) at the start of a regular expression:

```
> samplestring =~ regex "(?i)HIS";;
val it : bool = true

> samplestring =~ regex "HIS";;
val it : bool = false
```

This final example shows the use of named groups:

```
let entry = @"
Jolly Jethro
```



```
13 Kings Parade
Cambridge, Cambs CB2 1TJ
"
```

```
let re =
  regex @"(?<=\n)\s*(?<city>[^\n+]\s*,\s*(?<county>\w+)\s+(?<pcode>.{3}\s*.{3}).*$"
```

You can now use this regular expression to match the text and examine the named elements of the match:

---

```
> let r = re.Match(entry);;
val r : Match = Cambridge, Cambs CB2 1TJ
> r.Groups["city"].Value;;
val it : string = "Cambridge"
> r.Groups["county"].Value;;
val it : string = "Cambs"
> r.Groups["pcode"].Value;;
val it : string = "CB2 1TJ"
```

---

You can also combine regular expression matching with active patterns, which are described in Chapter 9. For example:

```
let (|IsMatch|_|) (re : string) (inp : string) =
  if Regex(re).IsMatch(inp) then Some() else None
```

This active pattern can now be used as:

---

```
> match "This is a string" with
| IsMatch "(?i)HIS" -> "yes, it matched"
| IsMatch "ABC" -> "this would not match"
| _ -> "nothing matched"

val it : string = "yes, it matched "
```

---

Likewise, you can define functions or active patterns that extract and return named results from the match:

```
let firstAndSecondWord (inp : string) =
  let re = regex "(?<word1>\w+)\s+(?<word2>\w+)"
  let results = re.Match(inp)
  if results.Success then
    Some (results.Groups["word1"].Value, results.Groups["word2"].Value)
  else
    None
```

---

```
> firstAndSecondWord "This is a super string"

val it : (string * string) option = Some ("This", "is")
```

---

The string-based lookup of group names “word1” and “word2” in the result set is a little dissatisfying in a strongly typed language, and there are a couple of things you can do to improve this. First, you can use the dynamic operator, described in Chapter 17, to make the lookups slightly more natural. This code requires

```
let (?) (results : Match) (name : string) =
    results.Groups.[name].Value

let firstAndSecondWord (inp : string) =
    let re = regex "(?<word1>\w+)\s+(?<word2>\w+)"
    let results = re.Match(inp)
    if results.Success then
        Some (results ? word1, results ? word2)
    else
        None
```

---

■ **Note** .NET regular expressions have many more features than those described here. For example, you can compile regular expressions to make them match very efficiently. You can also use regular expressions to define sophisticated text substitutions.

---

## Encoding and Decoding Unicode Strings

It's often necessary to convert string data between different formats. For example, files read using the `ReadLine` method on the `System.IO.StreamReader` type are read with respect to a Unicode encoding. You can specify this when creating the `StreamReader`. If left unspecified, the .NET libraries attempt to determine the encoding for you.

One common requirement is to convert strings to and from ASCII representations, assuming that all the characters in the strings are in the ASCII range 0 to 127. You can do this using `System.Text.Encoding.ASCII.GetString` and `System.Text.Encoding.ASCII.GetBytes`. Table 8-7 shows the predefined encodings and commonly used members in the `System.Text.Encoding` type.

*Table 8-7. Types and Members Related to Unicode Encodings*

Type/Member	Description
<code>System.Text.Encoding</code>	Represents a character encoding
<code>UTF8 : Encoding</code>	The encoding for the UTF-8 Unicode format
<code>ASCII : Encoding</code>	The encoding for the ASCII 7-bit character set
<code>Unicode : Encoding</code>	The encoding for the UTF-16 Unicode format
<code>UTF32 : Encoding</code>	The encoding for the UTF-32 Unicode format
<code>GetEncoding : string -&gt; Encoding</code>	Fetches an encoding by name
<code>member GetBytes : string -&gt; byte[]</code>	Encodes a string to bytes
<code>member GetChars : byte[] -&gt; char[]</code>	Decodes a sequence of bytes
<code>member GetString : byte[] -&gt; string</code>	Decodes a sequence of bytes

## Encoding and Decoding Binary Data

Another common requirement is to convert binary data to and from the standard 64-character, string-encoded representation of binary data used in XML, e-mail, and other formats. You can do this using `System.Convert.FromBase64String` and `System.Convert.ToBase64String`.

## Using XML as a Concrete Language Format

One common source of structured data in a textual format is the data formatted in the Extensible Markup Language (XML). F# comes with well-engineered libraries for reading and generating XML, which you can use to manipulate a typed abstract representation of an XML document in memory, without having to worry about parsing/generating strings corresponding to the XML.

## Using the System.Xml Namespace

XML is a general-purpose markup language; it is extensible, because it allows its users to define their own tags. Its primary purpose is to facilitate the sharing of data across different information systems, particularly via the Internet. Here is a sample fragment of XML, defined as a string directly in F#:

```
let inp = """<?xml version="1.0" encoding="utf-8" ?>
  <Scene>
    <Composite>
      <Circle radius='2' x='1' y='0' />
    <Composite>
      <Circle radius='2' x='4' y='0' />
      <Square side='2' left='-3' top='0' />
    </Composite>
    <Ellipse top='2' left='-2' width='3' height='4' />
  </Composite>
</Scene>"""
```

The backbone of an XML document is a hierarchical structure, and each node is decorated with attributes keyed by name. You can parse XML using the types and methods in the `System.Xml` namespace provided by the .NET libraries and then examine the structure of the XML interactively:

---

```
> open System.Xml;;
> let doc = new XmlDocument();;

val doc : XmlDocument

> doc.LoadXml(inp);;

val it : unit = ()

> doc.ChildNodes;;

val it : XmlNodeList =
  seq [seq []; seq [seq [seq []; seq [seq []; seq []]; seq []]]]
```

---

The default F# Interactive display for the `XmlNode` type isn't particularly useful. Luckily, you can add an interactive printer to the `fsi.exe` session using the `AddPrinter` method on the `fsi` object:

---

```
> fsi.AddPrinter(fun (x:XmlNode) -> x.OuterXml);;
> doc.ChildNodes;;
val it : XmlNodeList =
    seq
    [ <?xml version="1.0" encoding="utf-8"?>;
      <Scene><Composite><Circle radius="2" x="1" y="0" /><Composite>...</Scene> ]
> doc.ChildNodes.Item(1);;
val it : XmlNode =
    <Scene><Composite><Circle radius="2" x="1" y="0" /><Composite>...</Scene>
> doc.ChildNodes.Item(1).ChildNodes.Item(0);;
val it : XmlNode =
    <Composite><Circle radius="2" x="1" y="0" />...</Composite>
> doc.ChildNodes.Item(1).ChildNodes.Item(0).ChildNodes.Item(0);;
val it : XmlNode = <Circle radius="2" x="1" y="0" />
> doc.ChildNodes.Item(1).ChildNodes.Item(0).ChildNodes.Item(0).Attributes;;
val it : XmlAttributeCollection = seq [radius="2"; x="1"; y="0"]
```

---

Table 8-8 shows the most commonly used types and members from the `System.Xml` namespace.

**Table 8-8.** Commonly Used Types and Members from the `System.Xml` Namespace

Type/Member	Description
type <code>XmlNode</code>	Represents a single node in an XML document
member <code>ChildNodes</code>	Gets all the child nodes of an <code>XmlNode</code>
member <code>Attributes</code>	Gets all the attributes of an <code>XmlNode</code>
member <code>OuterXml</code>	Gets the XML text representing the node and all its children
member <code>InnerText</code>	Gets the concatenated values of the node and all its children
member <code>SelectNodes</code>	Selects child nodes using an XPath query
Type/Member	Description
type <code>XmlAttribute</code>	Represents one attribute for an <code>XmlNode</code> ; also an <code>XmlNode</code>
member <code>Value</code>	Gets the string value for the attribute
type <code>XmlDocument</code>	Represents an entire XML document; also an <code>XmlNode</code>
member <code>Load</code>	Populates the document from the given <code>XmlReader</code> , stream, or file name
member <code>LoadXml</code>	Populates the document object from the given XML string
type <code>XmlReader</code>	Represents a reader for an XML document or source
type <code>XmlWriter</code>	Represents a writer for an XML document

---

## From Concrete XML to Abstract Syntax

Often, your first task in processing a concrete language is to bring the language fragments under the type discipline of F#. This section shows how to transform the data contained in the XML from the previous section into an instance of the recursive type shown here. This kind of type is usually called an *abstract syntax tree* (AST):

```
open System.Drawing
type Scene =
    | Ellipse of RectangleF
    | Rect of RectangleF
    | Composite of Scene list
```

This example uses the types `PointF` and `RectangleF` from the `System.Drawing` namespace, although you can equally define your own types to capture the information carried by the leaves of the tree. Listing 8-1 shows a recursive transformation to convert XML documents like the one used in the previous section into the type `Scene`.

**Listing 8-1.** *Converting XML into a Typed Format Using the System.Xml Namespace*

```
open System.Xml
open System.Drawing
type Scene =
    | Ellipse of RectangleF
    | Rect of RectangleF
    | Composite of Scene list

    /// A derived constructor
    static member Circle(center : PointF, radius) =
        Ellipse(RectangleF(center.X - radius, center.Y - radius,
            radius * 2.0f, radius * 2.0f))

    /// A derived constructor
    static member Square(left, top, side) =
        Rect(RectangleF(left, top, side, side))

    /// Extract a number from an XML attribute collection
    let extractFloat32 attrName (attribs : XmlAttributeCollection) =
        float32 (attribs.GetNamedItem(attrName).Value)

    /// Extract a Point from an XML attribute collection
    let extractPointF (attribs : XmlAttributeCollection) =
        PointF(extractFloat32 "x" attribs, extractFloat32 "y" attribs)

    /// Extract a Rectangle from an XML attribute collection
    let extractRectangleF (attribs : XmlAttributeCollection) =
        RectangleF(extractFloat32 "left" attribs, extractFloat32 "top" attribs,
            extractFloat32 "width" attribs, extractFloat32 "height" attribs)

    /// Extract a Scene from an XML node
    let rec extractScene (node : XmlNode) =
```

```

let attribs = node.Attributes
let childNodes = node.ChildNodes
match node.Name with
| "Circle" ->
    Scene.Circle(extractPointF(attribs), extractFloat32 "radius" attribs)
| "Ellipse" ->
    Scene.Ellipse(extractRectangleF(attribs))
| "Rectangle" ->
    Scene.Rect(extractRectangleF(attribs))
| "Square" ->
    Scene.Square(extractFloat32 "left" attribs, extractFloat32 "top" attribs,
                 extractFloat32 "side" attribs)
| "Composite" ->
    Scene.Composite [for child in childNodes -> extractScene(child)]
| _ -> failwithf "unable to convert XML '%s'" node.OuterXml

```

*/// Extract a list of Scenes from an XML document*

```

let extractScenes (doc : XmlDocument) =
    [for node in doc.ChildNodes do
        if node.Name = "Scene" then
            yield (Composite
                [for child in node.ChildNodes -> extractScene(child)]]]

```

The inferred types of these functions are:

---

```

type Scene =
    | Ellipse of RectangleF
    | Rect of RectangleF
    | Composite of Scene list
with
    static member Circle : center:PointF * radius:float32 -> Scene
    static member Square : left:float32 * top:float32 * side:float32 -> Scene
end

val extractFloat32 :
    attrName:string -> attribs:XmlAttributeCollection -> float32
val extractPointF : attribs:XmlAttributeCollection -> PointF
val extractRectangleF : attribs:XmlAttributeCollection -> RectangleF
val extractScene : node:XmlNode -> Scene
val extractScenes : doc:XmlDocument -> Scene list

```

---

The definition of `extractScenes` in Listing 8-1 generates lists using sequence expressions, which are covered in Chapter 3. You can now apply the `extractScenes` function to the original XML. (You first add a pretty-printer to the F# Interactive session for the `RectangleF` type using the `AddPrinter` function on the `fsi` object.)

---

```

> fsi.AddPrinter(fun (r:RectangleF) ->
    sprintf "[%A,%A,%A,%A]" r.Left r.Top r.Width r.Height);;

```

```
> extractScenes doc;;

val it : Scene list
= [Composite
  [Composite
    [Ellipse [-1.0f, -2.0f, 4.0f, 4.0f];
     Composite [Ellipse [2.0f, -2.0f, 4.0f, 4.0f]; Rect [-3.0f, 0.0f, 2.0f, 2.0f]];
    Ellipse [-2.0f, 2.0f, 3.0f, 4.0f]]]]
```

---

The following sections more closely explain some of the choices we've made in the abstract syntax design for the type `Scene`.

---

■ **Tip** Translating to a typed representation isn't always necessary: some manipulations and analyses are better performed directly on heterogeneous, general-purpose formats, such as XML or even on strings. For example, XML libraries support XPath, accessed via the `SelectNodes` method on the `XmlNode` type. If you need to query a large, semistructured document whose schema is frequently changing in minor ways, using XPath is the right way to do it. Likewise, if you need to write a significant amount of code that interprets or analyzes a tree structure, converting to a typed abstract syntax tree is usually better.

---

## Some Recursive Descent Parsing

Sometimes, you want to tokenize and parse a nonstandard language format, such as XML or JSON. The typical task is to parse the user input into your internal representation by breaking down the input string into a sequence of tokens (“lexing”) and then constructing an instance of your internal representation based on a grammar (“parsing”). Lexing and parsing don't have to be separated, and there are often convenient .NET methods for extracting information from text in particular formats, as shown in this chapter. Nevertheless, it's often best to treat the two processes separately.

In this section, you implement a simple tokenizer and parser for a language of polynomial expressions for input text fragments, such as

```
x^5 - 2x^3 + 20
or
x + 3
```

The aim is simply to produce a structured value that represents the polynomial to permit subsequent processing. For example, this may be necessary when writing an application that performs simple symbolic differentiation—say, on polynomials only. You want to read polynomials, such as  $x^5 - 2x^3 + 20$ , as input from your users, which in turn is converted to your internal polynomial representation so that you can perform symbolic differentiation and pretty-print the result to the screen. One way to represent polynomials is as a list of terms that are added or subtracted to form the polynomial:

```
type Term =
  | Term of int * string * int
  | Const of int

type Polynomial = Term list
```

For instance, the polynomial  $x^5 - 2x^3 + 20$  is represented as:

```
[Term (1,"x",5); Term (-2,"x",3); Const 20]
```

## A Simple Tokenizer

First, you implement a tokenizer for the input, using regular expressions:

*Listing 8-2. Tokenizer for Polynomials Using Regular Expressions*

```
type Token =
  | ID of string
  | INT of int
  | HAT
  | PLUS
  | MINUS

let tokenR = regex @"((?<token>(\d+|\w+|\^|\+|-))\s*)*"

let tokenize (s : string) =
  [for x in tokenR.Match(s).Groups["token"].Captures do
    let token =
      match x.Value with
      | "^" -> HAT
      | "-" -> MINUS
      | "+" -> PLUS
      | s when System.Char.IsDigit s.[0] -> INT (int s)
      | s -> ID s
    yield token]
```

The inferred type of the function is:

---

```
val tokenize : s:string -> Token list
```

---

We can now test the tokenizer on some sample inputs:

---

```
> tokenize "x^5 - 2x^3 + 20";;

val it : Token list =
  [ID "x"; HAT; INT 5; MINUS; INT 2; ID "x"; HAT; INT 3; PLUS; INT 20]
```

---

The tokenizer works by simply matching the entire input string, and for each text captured by the labeled “token” pattern, we yield an appropriate token depending on the captured text.

## Recursive-Descent Parsing

You can now turn your attention to parsing. In Listing 8-2, you built a lexer and a token type suitable for generating a token stream for the input text (shown as a list of tokens here):



```
[ID "x"; HAT; INT 5; MINUS; INT 2; ID "x"; HAT; INT 3; PLUS; INT 20]
```

Listing 8-3 shows a *recursive-descent parser* that consumes this token stream and converts it into the internal representation of polynomials. The parser works by generating a lazy list for the token stream. Lazy lists are a data structure in the F# library module `Microsoft.FSharp.Collections.LazyList`, and they're a lot like sequences, with one major addition—lazy lists effectively allow you to pattern-match on a sequence and return a residue lazy list for the tail of the sequence.

**Listing 8-3.** *Recursive-descent Parser for Polynomials*

```
type Term =
    | Term of int * string * int
    | Const of int

type Polynomial = Term list
type TokenStream = Token list

let tryToken (src : TokenStream) =
    match src with
    | tok :: rest -> Some(tok, rest)
    | _ -> None

let parseIndex src =
    match tryToken src with
    | Some (HAT, src) ->
        match tryToken src with
        | Some (INT num2, src) ->
            num2, src
        | _ -> failwith "expected an integer after '^'"
    | _ -> 1, src

let parseTerm src =
    match tryToken src with
    | Some (INT num, src) ->
        match tryToken src with
        | Some (ID id, src) ->
            let idx, src = parseIndex src
            Term (num, id, idx), src
        | _ -> Const num, src
    | Some (ID id, src) ->
        let idx, src = parseIndex src
        Term(1, id, idx), src
    | _ -> failwith "end of token stream in term"

let rec parsePolynomial src =
    let t1, src = parseTerm src
    match tryToken src with
    | Some (PLUS, src) ->
        let p2, src = parsePolynomial src
        (t1 :: p2), src
    | _ -> [t1], src
```

```
let parse input =
  let src = tokenize input
  let result, src = parsePolynomial src
  match tryToken src with
  | Some _ -> failwith "unexpected input at end of token stream!"
  | None -> result
```

The functions here have these types (using the type aliases you defined):

---

```
val tryToken : src:TokenStream -> (Token * Token list) option
val parseIndex : src:TokenStream -> int * Token list
val parseTerm : src:TokenStream -> Term * Token list
val parsePolynomial : src:TokenStream -> Term list * Token list
val parse : input:string -> Term list
```

---

Note in the previous examples that you can successfully parse either constants or complete terms, but after you locate a HAT symbol, a number must follow. This sort of parsing, in which you look only at the next token to guide the parsing process, is referred to as *LL(1)*, which stands for left-to-right, leftmost derivation parsing; 1 means that only one look-ahead symbol is used. To conclude, you can look at the parse function in action:

---

```
> parse "1+3";;

val it : Term list = [Const 1; Const 3]

> parse "2x^2+3x+5";;

val it : Term list = [Term (2,"x",2); Term (3,"x",1); Const 5]
```

---

## Binary Parsing and Formatting

One final case of parsing is common when working with binary data. That is, say you want to work with a format that is conceptually relatively easy to parse and generate (such as a binary format) but in which the process of actually writing the code to crack and encode the format is somewhat tedious. This section covers a useful set of techniques to write readers and writers for binary data quickly and reliably.

The running example shows a set of *pickling* (also called *marshalling*) and *unpickling* combinators to generate and read a binary format of our design. You can easily adapt the combinators to work with existing binary formats, such as those used for network packets. Picklers and unpicklers for different data types are function values that have signatures as follows:

```
type OutState = System.IO.BinaryWriter
type InState = System.IO.BinaryReader

type Pickler<'T> = 'T -> OutState -> unit
type Unpickler<'T> = InState -> 'T
```

Here, *OutState* and *InState* are types that record information during the pickling or unpickling process. In this section, these are just binary readers and writers; more generally, they can be any type that

can collect information and help compact the data during the writing process, such as by ensuring that repeated strings are given unique identifiers during the pickling process.

At the heart of every such library lies a set of primitive leaf functions for the base cases of aggregate data structures. For example, when you're working with binary streams, this is the usual set of primitive read/write functions:

```
// P is the suffix for pickling and U is the suffix for unpickling
let byteP (b : byte) (st : OutState) = st.Write(b)
let byteU (st : InState) = st.ReadByte()
```

You can now begin to define additional pickler/unpickler pairs:

```
let boolP b st = byteP (if b then 1uy else 0uy) st
let boolU st = let b = byteU st in (b = 1uy)

let int32P i st =
  byteP (byte (i &&& 0xFF)) st
  byteP (byte ((i >>> 8) &&& 0xFF)) st
  byteP (byte ((i >>> 16) &&& 0xFF)) st
  byteP (byte ((i >>> 24) &&& 0xFF)) st

let int32U st =
  let b0 = int (byteU st)
  let b1 = int (byteU st)
  let b2 = int (byteU st)
  let b3 = int (byteU st)
  b0 ||| (b1 <<< 8) ||| (b2 <<< 16) ||| (b3 <<< 24)
```

These functions have the following types (to keep output readable, `Pickler` and `Unpickler` types are used in the output instead of their expanded version that is reported by F# Interactive):

---

```
val byteP : Pickler<byte>
val byteU : Unpickler<byte>
val boolP : Pickler<bool>
val boolU : Unpickler<bool>
val int32P : Pickler<int>
val int32U : Unpickler<int>
```

---

So far, so simple. One advantage of this approach comes as you write combinators that put these together in useful ways. For example, for tuples:

```
let tup2P p1 p2 (a, b) (st : OutState) =
  (p1 a st : unit)
  (p2 b st : unit)

let tup3P p1 p2 p3 (a, b, c) (st : OutState) =
  (p1 a st : unit)
  (p2 b st : unit)
  (p3 c st : unit)
```

```
let tup2U p1 p2 (st : InState) =
  let a = p1 st
  let b = p2 st
  (a, b)

let tup3U p1 p2 p3 (st : InState) =
  let a = p1 st
  let b = p2 st
  let c = p3 st
  (a, b, c)
```

and for lists:

```
/// Outputs a list into the given output stream by pickling each element via f.
/// A zero indicates the end of a list, a 1 indicates another element of a list.
let rec listP f lst st =
  match lst with
  | [] -> byteP 0uy st
  | h :: t -> byteP 1uy st; f h st; listP f t st

// Reads a list from a given input stream by unpickling each element via f.
let listU f st =
  let rec loop acc =
    let tag = byteU st
    match tag with
    | 0uy -> List.rev acc
    | 1uy -> let a = f st in loop (a :: acc)
    | n -> failwithf "listU: found number %d" n
  loop []
```

These functions conform to the types:

---

```
val tup2P : Pickler<'a> -> Pickler<'b> -> Pickler<'a * 'b>
val tup3P : Pickler<'a> -> Pickler<'b> -> Pickler<'c> -> Pickler<'a * 'b * 'c>
val tup2U : Unpickler<'a> -> Unpickler<'b> -> Unpickler<'a * 'b>
val tup3U : Unpickler<'a> -> Unpickler<'b> -> Unpickler<'c> -> Unpickler<'a * 'b * 'c>
val listP : Pickler<'a> -> Pickler<'a list>
val listU : Unpickler<'a> -> Unpickler<'a list>
```

---

It's now beginning to be easy to pickle and unpickle aggregate data structures using a consistent format. For example, imagine that the internal data structure is a list of integers and Booleans:

```
type format = list<int32 * bool>

let formatP = listP (tup2P int32P boolP)
let formatU = listU (tup2U int32U boolU)

open System.IO

let writeData file data =
```

```

    use outStream = new BinaryWriter(File.OpenWrite(file))
    formatP data outStream

let readData file =
    use inStream = new BinaryReader(File.OpenRead(file))
    formatU inStream

```

You can now invoke the pickle/unpickle process:

---

```

> writeData "out.bin" [(102, true); (108, false)] ;;

val it : unit = ()

> readData "out.bin";;

val it : (int * bool) list = [(102, true); (108, false)]

```

---

Combinator-based pickling is a powerful technique that can be taken well beyond what has been shown here. For example, it's possible to:

- Ensure data are compressed and shared during the pickling process by keeping tables in the input and output states. Sometimes this requires two or more phases in the pickling and unpickling process.
- Build in extra-efficient primitives that compress leaf nodes, such as writing out all integers using `BinaryWriter.Write7BitEncodedInt` and `BinaryReader.Read7BitEncodedInt`.
- Build extra combinators for arrays, sequences, and lazy values and for lists stored in binary formats other than the 0/1 tag scheme used here.
- Build combinators that allow dangling references to be written to the pickled data, usually written as a symbolic identifier. When the data are read, the identifiers must be resolved and relinked, usually by providing a function parameter that performs the resolution. This can be a useful technique when processing independent compilation units.

Combinator-based pickling is used mainly because it allows data formats to be created and read in a relatively bug-free manner. It isn't always possible to build a single pickling library suitable for all purposes, and you should be willing to customize and extend code samples, such as those listed previously, in order to build a set of pickling functions suitable for your needs.

---

■ **Note** Combinator-based parsing borders on a set of techniques called *parser combinators* that we don't cover in this book. The idea is very much the same as the combinators presented here; parsing is described using a compositional set of functions. You also can write parser combinators using the workflow notation described in Chapter 17.

---

## Summary

In this chapter, you explored several topics related to working with textual data. You learned about formatting text using both F# type-safe formatting and .NET formatting, some simple techniques to parse data to primitive types, and the basics of working with regular expressions. You also learned how to work with XML as a concrete text format for structured data. Finally, you learned how to use recursive descent parsing and some combinator-based approaches for generating and reading binary data to/from structured data types. The next chapter goes deeper into working with structured data itself using the strongly typed functional-programming facilities of .NET.

## CHAPTER 9



# Working with Sequences and Structured Data

In the previous chapter, you learned about some techniques used to manipulate *unstructured data*, including how to parse and format structured data as unstructured text. In this chapter, you focus on F# programming techniques related to *structured data*.

Structured data, and its processing, is a broad topic that lies at the heart of much applied F# programming. In this chapter, you will learn about a number of applied topics in structured programming, including:

- *building, transforming* and *querying* in-memory data structures—in particular, using sequence-based programming
- *working with abstract syntax representations*, including some efficiency-related representation techniques
- *building new data structures*, including implementing *equality* and *comparison* operations for these types
- *defining structured views* of existing data structures using *active patterns*
- using *recursion* and *tail-calls*, especially over recursively structured types.

Closely related to programming with structured data is the use of *recursion* in F# to describe some algorithms. In order to use recursion effectively over structured data, you will also learn about *tail calls* and how they affect the use of the “stack” as a computational resource.

## Getting Started with Sequences

Many programming tasks require the iteration, aggregation, and transformation of data streamed from various sources. One important and general way to code these tasks is in terms of values of the type `System.Collections.Generic.IEnumerable<type>`, which is typically abbreviated to `seq<type>` in F# code. A `seq<type>` is a value that can be *iterated*, producing results of type `type` on demand. Sequences are used to wrap collections, computations, and data streams and are frequently used to represent the results of database queries. The following sections present some simple examples of working with `seq<type>` values.

## Using Range Expressions

You can generate simple sequences using *range expressions*. For integer ranges, these take the form of `seq {n .. m}` for the integer expressions `n` and `m`:

---

```
> seq {0 .. 2};;
val it : seq<int> = seq [0; 1; 2;]
```

---

You can also specify range expressions using other numeric types, such as `double` and `single`:

---

```
> seq {-100.0 .. 100.0};;
val it : seq<float> = seq [-100.0; -99.0; -98.0; -97.0; ...]
```

---

By default, F# Interactive shows the value of a sequence only to a limited depth; `seq<'T>` values are *lazy* in the sense that they compute and return the successive elements on demand. This means you can create sequences representing very large ranges, and the elements of the sequence are computed only if they're required by a subsequent computation. In the next example, you don't actually create a concrete data structure containing one trillion elements, but rather, you create a sequence value that has the *potential* to yield this number of elements on demand. The default printing performed by F# Interactive forces this computation up to depth 4:

---

```
> seq {1I .. 10000000000000I};;
val it : seq<Numerics.BigInteger> = seq [1 ; 2; 3; ...]
```

---

The default increment for range expressions is always 1. A different increment can be used via range expressions of the form `seq {n .. skip .. m}`:

---

```
> seq {1 .. 2 .. 5};;
val it : seq<int> = seq [1; 3; 5]

> seq {1 .. -2 .. -5};;
val it : seq<int> = seq [1; -1; -3; -5]
```

---

If the skip causes the final element to be overshoot, then the final element isn't included in the result:

---

```
> seq {0 .. 2 .. 5};;
val it : seq<int> = seq [0; 2; 4]
```

---

The `(..)` and `(.. ..)` operators are overloaded operators in the same sense as `(+)` and `(-)`, which means their behavior can be altered for user-defined types. Chapter 6 discusses this in more detail.



## Iterating a Sequence

You can iterate sequences using the `for ... in ... do` construct, as well as the `Seq.iter` aggregate operator discussed in the next section. Here is a simple example of the first:

---

```
> let range = seq {0 .. 2 .. 6};;

val range : seq<int>

> for i in range do printfn "i = %d" i;;
i = 0
i = 2
i = 4
i = 6
```

---

This construct forces the iteration of the entire `seq`. Use it with care when you're working with sequences that may yield a large number of elements.

## Transforming Sequences with Aggregate Operators

Any value of type `seq<type>` can be iterated and transformed using functions in the `Microsoft.FSharp.Collections.Seq` module. For example:

---

```
> let range = seq {0 .. 10};;

val range : seq<int>

> range |> Seq.map (fun i -> (i,i*i));;

val it : seq<int * int> = seq [(0, 0); (1, 1); (2, 4); (3, 9); ...]
```

---

Table 9-1 shows some important functions in this library module. The following operators necessarily evaluate all the elements of the input `seq` immediately:

- `Seq.iter`: This iterates all elements, applying a function to each.
- `Seq.toList`: This iterates all elements, building a new list.
- `Seq.toArray`: This iterates all elements, building a new array.

Most other operators in the `Seq` module return one or more `seq<type>` values and force the computation of elements in any input `seq<type>` values only on demand.

*Table 9-1. Some Important Functions and Aggregate Operators from the Seq Module*

Operator	Type
<code>Seq.append</code>	<code>seq&lt;'T&gt; -&gt; seq&lt;'T&gt; -&gt; seq&lt;'T&gt;</code>
<code>Seq.concat</code>	<code>seq&lt;#seq&lt;'T&gt;&gt; -&gt; seq&lt;'T&gt;</code>
<code>Seq.choose</code>	<code>('T -&gt; 'U option) -&gt; seq&lt;'T&gt; -&gt; seq&lt;'U&gt;</code>

Operator	Type
Seq.delay	(unit -> seq<'T>) -> seq<'T>
Seq.empty	seq<'T>
Seq.iter	('T -> unit) -> seq<'T> -> unit
Seq.filter	('T -> bool) -> seq<'T> -> seq<'T>
Seq.map	('T -> 'U) -> seq<'T> -> seq<'U>
Seq.singleton	'T -> seq<'T>
Seq.truncate	int -> seq<'T> -> seq<'T>
Seq.toList	seq<'T> -> 'T list
Seq.ofList	'T list -> seq<'T>
Seq.toArray	seq<'T> -> 'T []
Seq.ofArray	'T [] -> seq<'T>

## Which Types Can Be Used as Sequences?

Table 9-1 includes many uses of types such as `seq<'T>`. When a type appears as the type of an argument, the function accepts any value that's compatible with this type. Chapter 5 explained the notions of subtyping and compatibility in more detail; the concept should be familiar to OO programmers because it's the same as that used by languages such as C#, which itself is close to that used by Java and C++. In practice, you can easily discover which types are compatible with which others by using F# Interactive and tools such as Visual Studio: when you hover over a type name, the compatible types are shown. You can also refer to the online documentation for the F# libraries and the .NET Framework, which you can easily obtain using the major search engines.

Here are some of the types compatible with `seq<'T>`:

- *Array types*: For example, `int []` is compatible with `seq<int>`.
- *F# list types*: For example, `int list` is compatible with `seq<int>`.
- *All other F# and .NET collection types*: For example, `System.Collections.Generic.SortedList<string>` is compatible with `seq<string>`.

## Using Lazy Sequences from External Sources

Sequences are frequently used to represent the process of streaming data from an external source, such as from a database query or from a computer's file system. For example, the following recursive function constructs a `seq<string>` that represents the process of recursively reading the names of all the files under a given path. The return types of `Directory.GetFiles` and `Directory.GetDirectories` are `string[]`; and, as noted earlier, this type is always compatible with `seq<string>`:

```
open System.IO
let rec allFiles dir =
    Seq.append
        (dir |> Directory.GetFiles)
        (dir |> Directory.GetDirectories |> Seq.map allFiles |> Seq.concat)
```

This gives the following type:

---

```
val allFiles : dir:string -> seq<string>
```

---

Here is an example of the function being used on one of our machines:

---

```
> allFiles @"c:\WINDOWS\system32";;

val it : seq<string> =
    seq
    ["c:\WINDOWS\system32\12520437.cpx"; "c:\WINDOWS\system32\12520850.cpx";
     "c:\WINDOWS\system32\aaclient.dll";
     "c:\WINDOWS\system32\accessibilitycpl.dll"; ...]
```

---

The `allFiles` function is interesting partly because it shows many aspects of F# working seamlessly together:

- *Functions as values:* The function `allFiles` is recursive and is used as a first-class function value within its own definition.
- *Pipelining:* The pipelining operator `|>` provides a natural way to present the transformations applied to each subdirectory name.
- *Type inference:* Type inference computes all types in the obvious way, without any type annotations.
- *NET interoperability:* The `System.IO.Directory` operations provide intuitive primitives, which can then be incorporated in powerful ways using succinct F# programs.
- *Laziness where needed:* The function `Seq.map` applies the argument function lazily (on demand), which means subdirectories aren't read until required.

One subtlety with programming with on-demand or lazy values such as sequences is that side effects such as reading and writing from an external store shouldn't in general happen until the lazy sequence value is consumed. For example, the previous `allFiles` function reads the top-level directory `C:\` as soon as `allFiles` is applied to its argument. This may not be appropriate if the contents of `C:\` are changing. You can delay the computation of the sequence by using the library function `Seq.delay` or by using a sequence expression, covered in the next section, in which delays are inserted automatically by the F# compiler.

## Using Sequence Expressions

Aggregate operators are a powerful way of working with `seq<type>` values. However, F# also provides a convenient and compact syntax called *sequence expressions* for specifying sequence values that can be built using operations such as `choose`, `map`, `filter`, and `concat`. You can also use sequence expressions to specify the shapes of lists and arrays. It's valuable to learn how to use sequence expressions:

- They're a compact way of specifying interesting data and generative processes.
- They're used to specify database queries when using data-access layers such as Microsoft's Language Integrated Queries (LINQ). See Chapter 15 for examples of using sequence expressions this way.

- They're one particular use of *computation expressions*, a more general concept that has several uses in F# programming. Chapter 9 discusses computation expressions, and we show how to use them for asynchronous and parallel programming in Chapter 13.

The simplest form of a sequence expression is `seq { for value in expr .. expr -> expr }`. Here, `->` should be read “yield.” This is a shorthand way of writing `Seq.map` over a range expression. For example, you can generate an enumeration of numbers and their squares as follows:

---

```
> let squares = seq { for i in 0 .. 10 -> (i, i * i) };;

val squares : seq<int * int>
```

---

The more complete form of this construct is `seq { for pattern in sequence -> expression }`. The pattern allows you to decompose the values yielded by the input enumerable. For example, you can consume the elements of `squares` using the pattern `(i, iSquared)`:

---

```
> seq { for (i, iSquared) in squares -> (i, iSquared, i * iSquared) };;

val it : seq<int * int * int> =
  seq [(0, 0, 0); (1, 1, 1); (2, 4, 8); (3, 9, 27); ...]
```

---

The input sequence can be a `seq<type>` or any type supporting a `GetEnumerator` method.

## Enriching Sequence Expressions with Additional Logic

A sequence expression often begins with `for ... in ...`, but you can use additional constructs. For example:

- *A secondary iteration*: `for pattern in seq do seq-expr`
- *A filter*: `if expression then seq-expr`
- *A conditional*: `if expression then seq-expr else seq-expr`
- *A let binding*: `let pattern = expression in seq-expr`
- *Yielding a value*: `yield expression`

Secondary iterations generate additional sequences, all of which are collected and concatenated together. Filters let you skip elements that don't satisfy a given predicate. To see both of these in action, the following computes a checkerboard set of coordinates for a rectangular grid:

```
let checkerboardCoordinates n =
  seq { for row in 1 .. n do
        for col in 1 .. n do
          let sum = row + col
          if sum % 2 = 0 then
            yield (row, col) }
```

---

```
> checkerboardCoordinates 3;;
val it : seq<int * int> = seq [(1, 1); (1, 3); (2, 2); (3, 1); ...]
```

---

Using `let` clauses in sequence expressions allows you to compute intermediary results. For example, the following code gets the creation time and last-access time for each file in a directory:

```
let fileInfo dir =
    seq { for file in Directory.GetFiles dir do
          let creationTime = File.GetCreationTime file
          let lastAccessTime = File.GetLastAccessTime file
          yield (file, creationTime, lastAccessTime)}
```

In the previous examples, each step of the iteration produces zero or one result. The final `yield` of a sequence expression can also be another sequence, signified through the use of the `yield!` keyword. The following sample shows how to redefine the `allFiles` function from the previous section using a sequence expression. Note that multiple generators can be included in one sequence expression; the results are implicitly collated together using `Seq.append`:

```
let rec allFiles dir =
    seq { for file in Directory.GetFiles dir do
          yield file
          for subdir in Directory.GetDirectories dir do
            yield! allFiles subdir}
```

## Generating Lists and Arrays Using Sequence Expressions

You can also use range and sequence expressions to build list and array values. The syntax is identical, except the surrounding braces are replaced by the usual `[ ]` for lists and `[| |]` for arrays (Chapter 4 discusses arrays in more detail):

---

```
> [1 .. 4];;
val it: int list = [1; 2; 3; 4]
> [for i in 0 .. 3 -> (i, i * i)];;
val it : (int * int) list = [(0,0); (1,1); (2,4); (3,9)]
> [|for i in 0 .. 3 -> (i, i * i)|];;
val it : (int * int) [|] = [| (0, 0); (1, 1); (2, 4); (3, 9) |]
```

---

■ **Caution** F# lists and arrays are finite data structures built immediately rather than on demand, so you must take care that the length of the sequence is suitable. For example, `[1I .. 1000000000I]` attempts to build a list that is 1 billion elements long.

---

## More on Working with Sequences

In this section, we look at more techniques for working with sequences of data. This extends the initial techniques you learned in the previous section. For example, consider the `map` and `filter` operations. You can use these operators in a straightforward manner to query and transform in-memory data. For instance, given a table representing some people in your contacts list, you can select those names that start with the letter *A* as:

```
// A table of people in our startup
let people =
  [("Amber", 27, "Design")
   ("Wendy", 35, "Events")
   ("Antonio", 40, "Sales")
   ("Petra", 31, "Design")
   ("Carlos", 34, "Marketing")]

// Extract information from the table of people
let namesOfPeopleStartingWithA =
  people
  |> Seq.map (fun (name, age, dept) -> name)
  |> Seq.filter (fun name -> name.StartsWith "A")
  |> Seq.toList
```

At the end of the set of sequence operations, we use `Seq.toList` to evaluate the sequence once and convert the results into a concrete list. Similarly, the following finds all those in the design department:

```
// Extract the names of designers from the table of people
let namesOfDesigners =
  people
  |> Seq.filter (fun (_, _, dept) -> dept = "Design")
  |> Seq.map (fun (name, _, _) -> name)
  |> Seq.toList
```

The output from evaluating these declarations is:

---

```
val people : (string * int * string) list =
  [("Amber", 27, "Design"); ("Wendy", 35, "Events"); ("Antonio", 40, "Sales");
   ("Petra", 31, "Design"); ("Carlos", 34, "Marketing")]
val namesOfPeopleStartingWithA : string list = ["Amber"; "Antonio"]
val namesOfDesigners : string list = ["Amber"; "Petra"]
```

---

The `map` and `filter` operations on sequences, arrays, lists, and other structured data types are examples of *queries*. In these cases, the queries are expressed by using pipelined combinators that accept the data structure as input. In database terminology, the “`map`” and “`filter`” operations are, respectively, called “`select`” and “`where`.” Sequence-based functional programming gives you the tools to apply in-memory query logic on all types that are compatible with the F# sequence type, such as F# lists, arrays, sequences, and anything else that implements the `IEnumerable<'a>/seq<'a>` interface.

In the rest of this section, you learn about additional operations over sequences. Some further statistical and numeric operations, such as summing and averaging over sequences, are described in Chapter 10.

## Using Other Sequence Operators: Truncate and Sort

The Seq module contains many other useful functions in addition to the map and filter operators, some of which were described in Chapter 3. For instance, a useful query-like function is Seq.truncate, which takes the first *n* elements of a sequence and discards the rest. Likewise, you can sort a sequence by using Seq.sort. In the following example, you extract the first 3,000 even numbers from an unbounded stream of random numbers, and for each you return a pair of the number and its square. The sort operation uses the default comparison semantics for the type of elements in the sequence.

```

/// A random-number generator
let rand = System.Random()

/// An infinite sequence of numbers
let randomNumbers = seq { while true do yield rand.Next(100000) }

/// The first 10 random numbers, sorted
let firstTenRandomNumbers =
    randomNumbers
    |> Seq.truncate 10
    |> Seq.sort                // sort ascending
    |> Seq.toList

/// The first 3000 even random numbers and sort them
let firstThreeThousandEvenNumbersWithSquares =
    randomNumbers
    |> Seq.filter (fun i -> i % 2 = 0) // "where"
    |> Seq.truncate 3000
    |> Seq.sort                // sort ascending
    |> Seq.map (fun i -> i, i*i)    // "select"
    |> Seq.toList

```

The output for evaluating this expression is:

---

```

// random - results will vary!

val randomNumbers : seq<int>
val firstTenRandomNumbers : int list =
    [9444; 14443; 15015; 20448; 31038; 46145; 69447; 85050; 85509; 92181]
val firstThreeThousandEvenNumbersWithSquares : (int * int) list =
    [(56, 3136); (62, 3844); (66, 4356); (68, 4624); (70, 4900); (86, 7396);
    (144, 20736); (238, 56644); (248, 61504); (250, 62500); ... ]

```

---

The operations Seq.sortBy and Seq.sortWith take custom key-extraction and key-comparison functions, respectively. For example, the next code sample takes the first 10 numbers from our random-number sequence and sorts them by the *last* digit only (so 17510 appears before 16351, because the last digit 0 is lower than 1):

```

/// The first 10 random numbers, sorted by last digit
let firstTenRandomNumbersSortedByLastDigit =
    randomNumbers
    |> Seq.truncate 10

```

```
|> Seq.sortBy (fun x -> x % 10)
|> Seq.toList
```

The output is:

---

```
val firstTenRandomNumbersSortedByLastDigit : int list =
  [51220; 56640; 88543; 97424; 90744; 11784; 23316; 1368; 71878; 89719]
```

---

## Selecting Multiple Elements From Sequences

Often, you will find yourself writing sequence transformations that select *multiple* elements or *zero-or-one* elements for each input element in the sequence. This is in contrast to the operation `Seq.map`, which always selects *one* new element. The types of `Seq.collect` and `Seq.choose` are:

---

```
module Seq =
  val choose : chooser : ('T -> 'U option) -> source : seq<'T> -> seq<'U>
  val collect : mapping : ('T -> #seq<'U>) -> source : seq<'T> -> seq<'U>
  val map : mapping : ('T -> 'U) -> source : seq<'T> -> seq<'U>
```

---

For example, given a list of numbers 1 to 10, the following sample shows how to select the “triangle” of numbers 1, 1, 2, 1, 2, 3, 1, 2, 3, 4, etc. At the end of the set of sequence operations, we use `Seq.toList` to evaluate the sequence once and convert the results into a concrete list.

```
// Take the first 10 numbers and build a triangle 1, 1, 2, 1, 2, 3, 1, 2, 3, 4, ...
let triangleNumbers =
  [ 1 .. 10 ]
  |> Seq.collect (fun i -> [ 1 .. i ] )
  |> Seq.toList
```

The output is:

---

```
val triangleNumbers : int list =
  [1; 1; 2; 1; 2; 3; 1; 2; 3; 4; 1; 2; 3; 4; 5; 1; 2; 3; 4; 5; 6; 1; 2; 3; 4;
  5; 6; 7; 1; 2; 3; 4; 5; 6; 7; 8; 1; 2; 3; 4; 5; 6; 7; 8; 9; 1; 2; 3; 4; 5;
  6; 7; 8; 9; 10]
```

---

Likewise, you can use `Seq.choose` for the special case in which returning only zero-or-one elements, returning an option value `None` to indicate no new elements are produced and `Some value` to indicate the production of one element. The `Seq.choose` operation is logically the same as combining a filter and `map` operation into a single step. In the example below, you create an 8x8 “game board” full of random numbers, in which each element of the data structure includes the index position and a “game value” at that position. (Note that you will reuse this data structure below to explore several other sequence operations.)

```
let gameBoard =
  [ for i in 0 .. 7 do
    for j in 0 .. 7 do
      yield (i,j,rand.Next(10)) ]
```



We then select the positions containing an even number:

```
let evenPositions =
  gameBoard
  |> Seq.choose (fun (i,j,v) -> if v % 2 = 0 then Some (i,j) else None)
  |> Seq.toList
```

The output is:

---

```
// random - results will vary!
val gameBoard : (int * int * int) list = [(0, 0, 9); (0, 1, 2); (0, 2, 8); (0, 3, 2); ...]
val evenPositions : (int * int) list = [(0, 1); (0, 2); (0, 3); ... ]
```

---

## Finding Elements and Indexes in Sequences

One of the most common operations in sequence programming is searching a sequence for an element that satisfies a specific criteria. The operations you use to do this are `Seq.find`, `Seq.findIndex` and `Seq.pick`. These both will raise an exception if an element or index is not found, and they also have corresponding nonfailing partners `Seq.tryFind`, `Seq.tryFindIndex` and `Seq.tryPick`. The types of these operations are:

---

```
module Seq =
  val find : predicate : ('T -> bool) -> source : seq<'T> -> 'T
  val findIndex : predicate : ('T -> bool) -> source : seq<'T> -> int
  val pick : chooser : ('T -> bool) -> source : seq<'T> -> 'T
  val tryFind : predicate : ('T -> bool) -> source : seq<'T> -> 'T option
  val tryFindIndex : predicate : ('T -> bool) -> source : seq<'T> -> int option
  val tryPick : chooser : ('T -> 'U option) -> source : seq<'T> -> 'U option
```

---

For example, given the board you defined above, you can search the game board for the first location with a zero game value by using `Seq.tryFind`. This will return `None` if the search fails and `Some value` if it succeeds. Likewise, you can combine a selection and projection into a single operation using `Seq.tryPick`.

```
let firstElementScoringZero =
  gameBoard |> Seq.tryFind (fun (i, j, v) -> v = 0)

let firstPositionScoringZero =
  gameBoard |> Seq.tryPick (fun (i, j, v) -> if v = 0 then Some(i, j) else None)
```

The output is:

---

```
// random - results will vary!

val firstElementScoringZero : (int * int * int) option = Some (1, 5, 0)
val firstPositionScoringZero : (int * int) option = Some (1, 5)
```

---

## Grouping and Indexing Sequences

Search operations such as `Seq.find` search the input sequence linearly, from left to right. Frequently, it will be critical to performance of your code to *index* your operations over your data structures. There are numerous ways to do this, usually by building an indexed data structure, such as a Dictionary (see Chapter 4) or an indexed functional map (see Chapter 3).

In the process of building an indexed collection, you will often start with sequences of data and then *group* the data into buckets. Grouping is also useful, for many other reasons, when categorizing data for structural and statistical purposes. In the following example, you group the elements of the `gameBoard` defined previously into buckets according to the game value at each position:

```
let positionsGroupedByGameValue =
    gameBoard
        |> Seq.groupBy (fun (i, j, v) -> v)
        |> Seq.sortBy (fun (k, v) -> k)
        |> Seq.toList
```

The output is:

---

```
val positionsGroupedByGameValue : (int * seq<int * int * int>) list =
  [(0, <seq>); (1, <seq>); (2, <seq>); (3, <seq>); (4, <seq>); (5, <seq>);
  (6, <seq>); (7, <seq>); (8, <seq>); (9, <seq>)]
```

---

Note that each element in the grouping is a key and a sequence of values for that key. It is very common to immediately post-process the results of grouping into a dictionary or map. The built-in functions `dict` and `Map.ofSeq` are useful for this purpose, as they build dictionaries and immutable tree-maps, respectively. For example:

```
let positionsIndexedByGameValue =
    gameBoard
        |> Seq.groupBy (fun (i, j, v) -> v)
        |> Seq.sortBy (fun (k, v) -> k)
        |> Seq.map (fun (k, v) -> (k, Seq.toList v))
        |> dict
let worstPositions = positionsIndexedByGameValue.[0]
let bestPositions = positionsIndexedByGameValue.[9]
```

The output is:

---

```
// random - results will vary!

val positionsIndexedByGameValue :
  System.Collections.Generic.IDictionary<int,(int * int * int) list>
val worstPositions : (int * int * int) list =
  [(0, 6, 0); (2, 1, 0); (2, 3, 0); (6, 0, 0); (7, 0, 0)]
val bestPositions : (int * int * int) list =
  [(0, 3, 9); (0, 7, 9); (5, 3, 9); (6, 4, 9); (6, 7, 9)]
```

---

Note that for highly-optimized grouping and indexing, it can be useful to rewrite your core indexed tables into direct uses of highly optimized data structures, such as `System.Collections.Generic.Dictionary`, as described in Chapter 4.

## Folding Sequences

Some of the most general operators supported by most F# data structures are `fold` and `foldBack`. These apply a function to each element of a collection and accumulate a result. For `fold` and `foldBack`, the function is applied in left-to-right or right-to-left order, respectively. If you use the name `fold`, the ordering typically is left to right. Both functions also take an initial value for the accumulator. For example:

---

```
> List.fold (fun acc x -> acc + x) 0 [4; 5; 6];;
val it : int = 15

> Seq.fold (fun acc x -> acc + x) 0.0 [4.0; 5.0; 6.0];;
val it : float = 15.0

> List.foldBack (fun x acc -> min x acc) [4; 5; 6; 3; 5] System.Int32.MaxValue;;
val it : int = 3
```

---

The following are equivalent, but no explicit anonymous function values are used:

---

```
> List.fold (+) 0 [4; 5; 6];;
val it : int = 15

> Seq.fold (+) 0.0 [4.0; 5.0; 6.0];;
val it : float = 15.0

> List.foldBack min [4; 5; 6; 3; 5] System.Int32.MaxValue;;
val it : int = 3
```

---

If used carefully, the various `foldBack` operators are pleasantly compositional, because they let you apply a selection function as part of the accumulating function:

---

```
> List.foldBack (fst >> min) [(3, "three"); (5, "five")] System.Int32.MaxValue;;
val it : int = 3
```

---

The F# library also includes more direct accumulation functions, such as `Seq.sum` and `Seq.sumBy`. These use a fixed accumulation function (addition) with a fixed initial value (zero), and they are described in Chapter 10.

---

■ **Caution:** Folding operators are very powerful and can help you avoid many explicit uses of recursion or loops in your code. They're sometimes overused in functional programming, however, and they can be hard for novice users to read and understand. Take the time to document uses of these operators, or consider using them to build simpler operators that apply a particular accumulation function.

---

## Cleaning Up in Sequence Expressions

It's common to implement sequence computations that access external resources such as databases but that return their results on demand. This raises a difficulty: how do you manage the lifetime of the resources for the underlying operating-system connections? One elegant solution is via use bindings in sequence expressions:

- When a use binding occurs in a sequence expression, the resource is initialized each time a client enumerates the sequence.
- The connection is closed when the client disposes of the enumerator.

For example, consider the following function that creates a sequence expression that reads the first two lines of a file on demand:

```
open System.IO
```

```
let firstTwoLines file =
    seq {use s = File.OpenText(file)
        yield s.ReadLine()
        yield s.ReadLine()}
```

Let's now create a file and a sequence that reads the first two lines of the file on demand:

---

```
> File.WriteAllLines("test1.txt", [|"Es kommt ein Schiff";
                                   "A ship is coming"|]);
> let twolines() = firstTwoLines "test1.txt";

val twolines : unit -> seq<string>
```

---

At this point, the file hasn't yet been opened, and no lines have been read from the file. If you now iterate the sequence expression, the file is opened, the first two lines are read, and the results are consumed from the sequence and printed. Most important, the file has now also been closed, because the `Seq.iter` aggregate operator is careful to dispose of the underlying enumerator it uses for the sequence, which in turn disposes of the file handle generated by `File.OpenText`:

---

```
> twolines() |> Seq.iter (printfn "line = '%s'")

line = 'Es kommt ein Schiff'
line = 'A ship is coming'
```

---

## Expressing Some Operations Using Sequence Expressions

Sequences written using `map`, `filter`, `choose`, and `collect` can often be rewritten to use a sequence expression, as described in Chapter 3. For example, the `triangleNumbers` and `evenPositions` examples above can also be written as:

```
let triangleNumbers =
    [for i in 1 .. 10 do
      for j in 1 .. i do
        yield (i, j)]

let evenPositions =
    [for (i, j, v) in gameBoard do
      if v % 2 = 0 then
        yield (i, j)]
```

The output in each case is the same. In many cases, rewriting to use generative sequence expressions results in considerably clearer code. There are pros and cons to using sequence-expression syntax for some parts of queries:

- Sequence expressions are very good for the subset of queries expressed using iteration (`for`), filtering (`if/then`), and mapping (`yield`). They're particularly good for queries containing multiple nested `for` statements.
- Other query constructs, such as ordering, truncating, grouping, and aggregating, must be expressed directly using aggregate operators, such as `Seq.sortBy` and `Seq.groupBy`, or by using the more general notion of “query expressions” (see Chapter 14).
- Some queries depend on the index position of an item within a stream. These are best expressed directly using aggregate operators such as `Seq.mapI`.
- Many queries are part of a longer series of transformations chained by `|>` operators. Often, the type of the data being transformed at each step varies substantially through the chain of operators. These queries are best expressed using operator chains.

---

■ **Note:** F# also has a more general “query-expression” syntax that includes support for specifying grouping, aggregation, and joining operations. This is mostly used for querying external data sources and is discussed in Chapter 14.

---

## Structure Beyond Sequences: Working with Trees

In Chapter 5, you learned about some simple techniques to represent record and tree-structured data in F# using *record types* and *union types*. In Chapter 8, you learned how to move from an unstructured, textual representation such as XML to a structured, tree-like structures representation of the input data. In the following sections, you will learn techniques for working with structured data, in particular tree structures associated with the representation of the abstract syntax of languages. In particular, you will look at some important recurring techniques in designing and working with *abstract syntax representations*.

## Example: Abstract Syntax Representations

Let's look at the design of the abstract syntax type `Scene` from Listing 9-1. The type `Scene` uses fewer kinds of nodes than the concrete XML representation: the concrete XML has node kinds `Circle`, `Square`, `Composite`, and `Ellipse`, whereas `Scene` has just three (`Rect`, `Ellipse`, and `Composite`), with two derived constructors, `Circle` and `Square`, defined as static members of the `Scene`:

```
static member Circle(center:PointF,radius) =
    Ellipse(RectangleF(center.X-radius,center.Y-radius,
        radius*2.0f,radius*2.0f))

/// A derived constructor
static member Square(left,top,side) =
    Rect(RectangleF(left,top,side,side))
```

This is a common step when abstracting from a concrete syntax; details are dropped and unified to make the abstract representation simpler and more general. Extra functions are then added that compute specific instances of the abstract representation. This approach has pros and cons:

- Transformational and analytical manipulations are almost always easier to program if you have fewer constructs in your abstract syntax representation.
- You must be careful not to eliminate truly valuable information from an abstract representation. For some applications, it may really matter if the user specified a `Square` or a `Rectangle` in the original input; for example, an editor for this data may provide different options for editing these objects.

The AST uses the types `PointF` and `RectangleF` from the `System.Drawing` namespace. This simplification is a design decision that should be assessed: `PointF` and `RectangleF` use 32-bit, low-precision, floating-point numbers, which may not be appropriate if you're eventually rendering on high-precision display devices. You should be wary of deciding on abstract representations on the basis of convenience alone, although of course this is useful during prototyping.

The lesson here is that you should look carefully at your abstract syntax representations, trimming out unnecessary nodes and unifying nodes where possible, but only as long as doing so helps you achieve your ultimate goals.

Common operations on abstract syntax trees include traversals that collect information and transformations that generate new trees from old. For example, the abstract representation from Listing 9-1 has the property that, for nearly all purposes, the `Composite` nodes are irrelevant (this wouldn't be the case if you added an extra construct, such as an `Intersect` node). This means you can flatten to a sequence of `Ellipse` and `Rectangle` nodes:

```
let rec flatten scene =
    seq { match scene with
        | Composite scenes -> for x in scenes do yield! flatten x
        | Ellipse _ | Rect _ -> yield scene }
```

Here, `flatten` is defined using sequence expressions, introduced in Chapter 3. Its type is:

---

```
val flatten : scene:Scene -> seq<Scene>
```

---

Let's look at this more closely. Recall from Chapter 3 that sequences are on-demand (lazy) computations. Using functions that recursively generate `seq<'T>` objects can lead to inefficiencies in your

code if your abstract syntax trees are deep. It's often better to traverse the entire tree in an *eager* way (eager traversals run to completion immediately). For example, it's typically faster to use an accumulating parameter to collect a list of results. Here's an example:

```
let rec flattenAux scene acc =
    match scene with
    | Composite(scenes) -> List.foldBack flattenAux scenes acc
    | Ellipse _
    | Rect _ -> scene :: acc

let flatten2 scene = flattenAux scene [] |> Seq.ofList
```

The following does an eager traversal using a local mutable instance of a `ResizeArray` as the accumulator and then returns the result as a sequence. This example uses a local function and ensures that the mutable state is locally encapsulated:

```
let flatten3 scene =
    let acc = new ResizeArray<>()
    let rec flattenAux s =
        match s with
        | Composite(scenes) -> scenes |> List.iter flattenAux
        | Ellipse _ | Rect _ -> acc.Add s
    flattenAux scene;
    Seq.readonly acc
```

The types of these are:

---

```
val flatten2 : scene:Scene -> seq<Scene>
val flatten3 : scene:Scene -> seq<Scene>
```

---

There is no hard and fast rule about which of these is best. For prototyping, the second option—doing an efficient, eager traversal with an accumulating parameter—is often the most effective. Even if you implement an accumulation using an eager traversal, however, returning the result as an on-demand sequence still can give you added flexibility later in the design process.

## Transforming Abstract Syntax Representations

In the previous section, you saw examples of accumulating traversals of a syntax representation. It's common to traverse abstract syntax in other ways:

- *Leaf rewriting (mapping)*: Translating some leaf nodes of the representation but leaving the overall shape of the tree unchanged
- *Bottom-up rewriting*: Traversing a tree but making local transformations on the way up
- *Top-down rewriting*: Traversing a tree, but before traversing each subtree, attempting to locally rewrite the tree according to some particular set of rules
- *Accumulating and rewriting transformations*: For example, transforming the tree left to right but accumulating a parameter along the way

For example, this mapping transformation rewrites all leaf ellipses to rectangles:

```
let rec rectanglesOnly scene =
  match scene with
  | Composite scenes -> Composite (scenes |> List.map rectanglesOnly)
  | Ellipse rect | Rect rect -> Rect rect
```

Often, whole classes of transformations are abstracted into aggregate transformation operations, taking functions as parameters. For example, here is a function that applies one function to each leaf rectangle:

```
let rec mapRects f scene =
  match scene with
  | Composite scenes -> Composite (scenes |> List.map (mapRects f))
  | Ellipse rect -> Ellipse (f rect)
  | Rect rect -> Rect (f rect)
```

The types of these functions are:

---

```
val rectanglesOnly : scene:Scene -> Scene
val mapRects : f:(RectangleF -> RectangleF) -> scene:Scene -> Scene
```

---

Here is a use of the `mapRects` function to adjust the aspect ratio of all the `RectangleF` values in the scene (`RectangleF` values support an `Inflate` method):

```
let adjustAspectRatio scene =
  scene |> mapRects (fun r -> RectangleF.Inflate(r, 1.1f, 1.0f / 1.1f))
```

## Using On-Demand Computation with Abstract Syntax Trees

Sometimes it's feasible to delay loading or processing some portions of an abstract syntax tree. For example, imagine if the XML for the small geometric language from the previous section included a construct such as the following, in which the `File` nodes represent entire subtrees defined in external files:

```
<Composite>
  <File file='spots.xml' />
  <File file='dots.xml' />
</Composite>
```

It may be useful to delay loading these files. One general way to do this is to add a `Delay` node to the `Scene` type:

```
type Scene =
  | Ellipse of RectangleF
  | Rect of RectangleF
  | Composite of Scene list
  | Delay of Lazy<Scene>
```

You can then extend the `extractScene` function of Listing 9-1 with the following case to handle this node:



```
let rec extractScene (node : XmlNode) =
    let attrs = node.Attributes
    let childNodes = node.ChildNodes
    match node.Name with
    | "Circle" ->
        ...
    | "File" ->
        let file = attrs.GetNamedItem("file").Value
        let scene = lazy (let d = XmlDocument()
                          d.Load(file)
                          extractScene(d :> XmlNode))
        Scene.Delay scene
```

Code that analyzes trees (for example, via pattern matching) must typically be adjusted to force the computation of delayed values. One way to handle this is to first call a function to eliminate immediately delayed values:

```
let rec getScene scene =
    match scene with
    | Delay d -> getScene (d.Force())
    | _ -> scene
```

Here is the function `flatten2` from the “Processing Abstract Syntax Representations” section, but redefined to first eliminate delayed nodes:

```
let rec flattenAux scene acc =
    match getScene(scene) with
    | Composite scenes -> List.foldBack flattenAux scenes acc
    | Ellipse _ | Rect _ -> scene :: acc
    | Delay _ -> failwith "this lazy value should have been eliminated by getScene"

let flatten2 scene = flattenAux scene []
```

It’s generally advisable to have a single representation of laziness within a single syntax tree design. For example, the following abstract syntax design uses laziness in too many ways:

```
type SceneVeryLazy =
    | Ellipse of Lazy<RectangleF>
    | Rect of Lazy<RectangleF>
    | Composite of seq<SceneVeryLazy>
    | LoadFile of string
```

The shapes of ellipses and rectangles are lazy computations; each `Composite` node carries a `seq<SceneVeryLazy>` value to compute subnodes on demand, and a `LoadFile` node is used for delayed file loading. This is a bit of a mess, because a single `Delay` node would, in practice, cover all these cases.

---

■ **Note:** The `Lazy<'T>` type is defined in `System` and represents delayed computations. You access a lazy value via the `Value` property. F# includes the special keyword `lazy` for constructing values of this type. Chapter 8 also covered lazy computations.

---

## Caching Properties in Abstract Syntax Trees

For high-performance applications of abstract syntax trees, it can occasionally be useful to cache computations of some derived attributes within the syntax tree itself. For example, let's say you want to compute bounding boxes for the geometric language described in Listing 9-1. It's potentially valuable to cache this computation at Composite nodes. You can use a type such as the following to hold a cache:

```
type SceneWithCachedBoundingBox =
  | Ellipse of RectangleF
  | Rect of RectangleF
  | CompositeRepr of SceneWithCachedBoundingBox list * RectangleF option ref
```

This is useful for prototyping, although you should be careful to encapsulate the code that is responsible for maintaining this information. Listing 9-1 shows the full code for doing this.

*Listing 9-1. Adding the cached computation of a local attribute to an abstract syntax tree*

```
type SceneWithCachedBoundingBox =
  | Ellipse of RectangleF
  | Rect of RectangleF
  | CompositeRepr of SceneWithCachedBoundingBox list * RectangleF option ref

member x.BoundingBox =
  match x with
  | Ellipse rect | Rect rect -> rect
  | CompositeRepr (scenes, cache) ->
    match !cache with
    | Some v -> v
    | None ->
      let bbox =
        scenes
        |> List.map (fun s -> s.BoundingBox)
        |> List.reduce (fun r1 r2 -> RectangleF.Union(r1, r2))
      cache := Some bbox
      bbox

/// Create a Composite node with an initially empty cache
static member Composite(scenes) = CompositeRepr(scenes, ref None)
```

Other attributes that are sometimes cached include the hash values of tree-structured terms and the computation of all the identifiers in a subexpression. The use of caches makes it more awkward to pattern-match on terms. This issue can be largely solved by using active patterns, covered later in this chapter.

## Memoizing Construction of Syntax Tree Nodes

In some cases, abstract syntax tree nodes can end up consuming significant portions of the application's memory budget. In this situation, it can be worth memoizing some or all of the nodes constructed in the tree. You can even go as far as memoizing *all* equivalent nodes, ensuring that equivalence between nodes can be implemented by pointer equality, a technique often called *hash-consing*. Listing 9-2 shows an abstract representation of propositional logic terms that ensures that any two nodes that are syntactically

identical are shared via a memoizing table. Propositional logic terms are terms constructed using  $P$  AND  $Q$ ,  $P$  OR  $Q$ , NOT  $P$ , and variables  $a$ ,  $b$ , and so on. A noncached version of the expressions is:

```
type Prop =
  | And of Prop * Prop
  | Or of Prop * Prop
  | Not of Prop
  | Var of string
  | True
```

*Listing 9-2. Memoizing the construction of abstract syntax tree nodes*

```
type Prop =
  | Prop of int

and PropRepr =
  | AndRepr of Prop * Prop
  | OrRepr of Prop * Prop
  | NotRepr of Prop
  | VarRepr of string
  | TrueRepr

open System.Collections.Generic

module PropOps =

  let internal uniqStamp = ref 0
  type internal PropTable() =
    let fwdTable = new Dictionary<PropRepr, Prop>(HashIdentity.Structural)
    let bwdTable = new Dictionary<int, PropRepr>(HashIdentity.Structural)
    member t.ToUnique repr =
      if fwdTable.ContainsKey repr then fwdTable.[repr]
      else let stamp = incr uniqStamp; !uniqStamp
            let prop = Prop stamp
            fwdTable.Add (repr, prop)
            bwdTable.Add (stamp, repr)
            prop
    member t.FromUnique (Prop stamp) =
      bwdTable.[stamp]

  let internal table = PropTable ()

  // Public construction functions
  let And (p1, p2) = table.ToUnique (AndRepr (p1, p2))
  let Not p = table.ToUnique (NotRepr p)
  let Or (p1, p2) = table.ToUnique (OrRepr (p1, p2))
  let Var p = table.ToUnique (VarRepr p)
  let True = table.ToUnique TrueRepr
  let False = Not True
```

```
// Deconstruction function
let getRepr p = table.FromUnique p
```

You can construct terms using the operations in `PropOps` much as you would construct terms using the nonmemoized representation:

```
> open PropOps;;
> True;;

val it : Prop = Prop 1

> And (Var "x",Var "y");;

val it : Prop = Prop 5

> getRepr it;;

val it : PropRepr = AndRepr(Prop 3, Prop 4)

> And(Var "x",Var "y");;

val it : Prop = Prop 5
```

In this example, when you create two syntax trees using the same specification, `And (Var "x",Var "y")`, you get back the same `Prop` object with the same stamp 5. You can also use memoization techniques to implement interesting algorithms; in Chapter 12, you see an important representation of propositional logic called a *binary decision diagram* (BDD) based on a memoization table similar to the previous example.

The use of unique integer stamps and a lookaside table in the previous representation also has some drawbacks; it's harder to pattern match on abstract syntax representations, and you may need to reclaim and recycle stamps and remove entries from the lookaside table if a large number of terms is created or if the overall set of stamps must remain compact. You can solve the first problem by using active patterns, covered next in this chapter. If necessary, you can solve the second problem by scoping stamps in an object that encloses the `uniqStamp` state, the lookaside table, and the construction functions. Alternatively, you can explicitly reclaim the stamps by using the `IDisposable` idiom described in Chapter 8, although this approach can be intrusive to your application.

## Active Patterns: Views for Structured Data

Pattern matching is a key technique provided in `F#` for decomposing abstract syntax trees and other abstract representations of languages. So far in this book, all the examples of pattern matching have been directly over the core representations of data structures: for example, directly matching on the structure of lists, options, records, and discriminated unions. But pattern matching in `F#` is also *extensible*—that is, you can define new ways of matching over existing types. You do this through a mechanism called *active patterns*.

This book covers only the basics of active patterns. They can be indispensable, because they can let you continue to use pattern matching with your types even after you hide their representations. Active patterns also let you use pattern matching with `.NET` object types. The following section covers active patterns and how they work.

## Converting the Same Data to Many Views

In high-school math courses, you were probably taught that you can view complex numbers in two ways: as rectangular coordinates  $x + yi$  or as polar coordinates of a phase  $r$  and magnitude  $\phi$ . In most computer systems, complex numbers are stored in the first format, although often the second format is more useful.

Wouldn't it be nice if you could look at complex numbers through either lens? You could do this by explicitly converting from one form to another when needed, but it would be better to have your programming language look after the transformations needed to do this for you. Active patterns let you do exactly that. First, here is a standard definition of complex numbers:

```
[<Struct>]
type Complex(r : float, i : float) =
  static member Polar(mag, phase) = Complex(mag * cos phase, mag * sin phase)
  member x.Magnitude = sqrt(r * r + i * i)
  member x.Phase = atan2 i r
  member x.RealPart = r
  member x.ImaginaryPart = i
```

Here is a pattern that lets you view complex numbers as rectangular coordinates:

```
let (|Rect|) (x : Complex) = (x.RealPart, x.ImaginaryPart)
```

Here is an active pattern to help you view complex numbers in polar coordinates:

```
let (|Polar|) (x : Complex) = (x.Magnitude, x.Phase)
```

The key thing to note is that these definitions let you use `Rect` and `Polar` as tags in pattern matching. For example, you can now write the following to define addition and multiplication over complex numbers:

```
let addViaRect a b =
  match a, b with
  | Rect (ar, ai), Rect (br, bi) -> Complex (ar + br, ai + bi)

let mulViaRect a b =
  match a, b with
  | Rect (ar, ai), Rect (br, bi) -> Complex (ar * br - ai * bi, ai * br + bi * ar)
```

As it happens, multiplication on complex numbers is easier to express using polar coordinates, implemented as:

```
let mulViaPolar a b =
  match a, b with
  | Polar (m, p), Polar (n, q) -> Complex.Polar (m * n, p + q)
```

Here is an example of using the `(|Rect|)` and `(|Polar|)` active patterns directly on some complex numbers via the pattern tags `Rect` and `Polar`. You first make the complex number  $3+4i$ :

---

```
> fsi.AddPrinter (fun (c : Complex) -> sprintf "%gr + %gi" c.RealPart c.ImaginaryPart)
```

```

> let c = Complex (3.0, 4.0);;

val c : Complex = 3r + 4i

> c;;

val it : Complex = 3r + 4i

> match c with
| Rect (x, y) -> printfn "x = %g, y = %g" x y;;

x = 3, y = 4

> match c with
| Polar (x, y) -> printfn "x = %g, y = %g" x y;;

x = 5, y = 0.927295

> addViaRect c c;;

val it : Complex = 6r + 8i

> mulViaRect c c;;

val it : Complex = -7r + 24i

> mulViaPolar c c;;

val it : Complex = -7r + 24i

```

---

As you may expect, you get the same results if you multiply via rectangular or polar coordinates. The execution paths are quite different, however. Let's look closely at the definition of `mulViaRect`:

```

let mulViaRect a b =
  match a, b with
  | Rect (ar, ai), Rect (br, bi) ->
    Complex (ar * br - ai * bi, ai * br + bi * ar)

```

When F# needs to match the values `a` and `b` against the patterns `Rect (ar, ai)` and `Rect (br, bi)`, it doesn't look at the contents of `a` and `b` directly. Instead, it runs a function as part of pattern matching (which is why they're called *active* patterns). In this case, the function executed is `(|Rect|)`, which produces a pair as its result. The elements of the pair are then bound to the variables `ar` and `ai`. Likewise, in the definition of `mulViaPolar`, the matching is performed partly by running the function `(|Polar|)`.

The functions `(|Rect|)` and `(|Polar|)` are allowed to do anything, as long as each ultimately produces a pair of results. Here are the types of `(|Rect|)` and `(|Polar|)`:

```

val ( |Rect| ) : x:Complex -> float * float
val ( |Polar| ) : x:Complex -> float * float

```

---

These types are identical, but they implement completely different views of the same data.

The definitions of `addViaRect` and `mulViaPolar` can also be written using pattern matching in argument position:

```
let add2 (Rect (ar, ai)) (Rect (br, bi)) = Complex (ar + br, ai + bi)
let mul2 (Polar (r1, th1)) (Polar (r2, th2)) = Complex (r1 * r2, th1 + th2)
```

## Matching on .NET Object Types

One useful thing about active patterns is that they let you use pattern matching with existing .NET object types. For example, the .NET object type `System.Type` is a runtime representation of types in .NET and F#. Here are the members found on this type:

---

```
type System.Type with
    member IsGenericType : bool
    member GetGenericTypeDefinition : unit -> Type
    member GetGenericArguments : unit -> Type[]
    member HasElementType : bool
    member GetElementType : unit -> Type
    member IsByRef : bool
    member IsPointer : bool
    member IsGenericParameter : bool
    member GenericParameterPosition : int
```

---

This type looks very much like one you'd like to pattern match against. There are clearly three or four distinct cases here, and pattern matching helps you isolate them. You can define an active pattern to achieve this, as shown in Listing 9-3.

**Listing 9-3.** Defining an active pattern for matching on `System.Type` values

```
let (|Named|Array|Ptr|Param|) (typ : System.Type) =
    if typ.IsGenericType
    then Named(typ.GetGenericTypeDefinition(), typ.GetGenericArguments())
    elif typ.IsGenericParameter then Param(typ.GenericParameterPosition)
    elif not typ.HasElementType then Named(typ, [||])
    elif typ.IsArray then Array(typ.GetElementType(), typ.GetArrayRank())
    elif typ.IsByRef then Ptr(true, typ.GetElementType())
    elif typ.IsPointer then Ptr(false, typ.GetElementType())
    else failwith "MSDN says this can't happen"
```

This then lets you use pattern matching against a value of this type:

```
open System

let rec formatType typ =
    match typ with
    | Named (con, [||]) -> sprintf "%s" con.Name
    | Named (con, args) -> sprintf "%s<%s>" con.Name (formatTypes args)
    | Array (arg, rank) -> sprintf "Array(%d,%s)" rank (formatType arg)
    | Ptr(true, arg) -> sprintf "%s&" (formatType arg)
```

```

    | Ptr(false, arg) -> sprintf "%s*" (formatType arg)
    | Param(pos) -> sprintf "!"%d" pos

and formatTypes typs =
    String.Join(",", Array.map formatType typs)

or collect the free generic type variables:

let rec freeVarsAcc typ acc =
    match typ with
    | Array (arg, rank) -> freeVarsAcc arg acc
    | Ptr (_, arg) -> freeVarsAcc arg acc
    | Param _ -> (typ :: acc)
    | Named (con, args) -> Array.foldBack freeVarsAcc args acc

let freeVars typ = freeVarsAcc typ []

```

## Defining Partial and Parameterized Active Patterns

Active patterns can also be *partial*. You can recognize a partial pattern by a name such as (`|MulThree|_|`) and by the fact that it returns a value of type `'T option` for some `'T`. For example:

```

let (|MulThree|_|) inp = if inp % 3 = 0 then Some(inp / 3) else None
let (|MulSeven|_|) inp = if inp % 7 = 0 then Some(inp / 7) else None

```

Finally, active patterns can also be *parameterized*. You can recognize a parameterized active pattern by the fact that it takes several arguments. For example:

```

let (|MulN|_|) n inp = if inp % n = 0 then Some(inp / n) else None

```

The F# quotation API `Microsoft.FSharp.Quotations` uses both parameterized and partial patterns extensively.

## Hiding Abstract Syntax Implementations with Active Patterns

Earlier in this chapter, you saw the following type that defines an optimized representation of propositional logic terms using a unique stamp for each syntactically unique term:

```

type Prop = Prop of int
and internal PropRepr =
    | AndRepr of Prop * Prop
    | OrRepr of Prop * Prop
    | NotRepr of Prop
    | VarRepr of string
    | TrueRepr

```

What happens, however, if you want to pattern match against values of type `Prop`? Even if you exposed the representation, all you would get is an integer, which you would have to look up in an internal table. You can define an active pattern for restoring matching on that data structure, as shown in Listing 9-4.



**Listing 9-4.** Extending Listing 9-2 with an active pattern for the optimized representation

```

module PropOps =
  ...
  let (|And|Or|Not|Var|True|) prop =
    match table.FromUnique prop with
    | AndRepr (x, y) -> And (x, y)
    | OrRepr (x, y) -> Or (x, y)
    | NotRepr x -> Not x
    | VarRepr v -> Var v
    | TrueRepr -> True

```

This code defines an active pattern in the auxiliary module `PropOps` that lets you pattern match against `Prop` values, despite the fact that they're using optimized unique-integer references under the hood. For example, you can define a pretty-printer for `Prop` terms as follows, even though they're using optimized representations:

```

open PropOps

let rec showProp precedence prop =
  let parenIfPrec lim s = if precedence < lim then "(" + s + ")" else s
  match prop with
  | Or (p1, p2) -> parenIfPrec 4 (showProp 4 p1 + " || " + showProp 4 p2)
  | And (p1, p2) -> parenIfPrec 3 (showProp 3 p1 + " && " + showProp 3 p2)
  | Not p -> parenIfPrec 2 ("not " + showProp 1 p)
  | Var v -> v
  | True -> "T"

```

Likewise, you can define functions to place the representation in various normal forms. For example, the following function computes *negation normal form* (NNF), where all instances of NOT nodes have been pushed to the leaves of the representation:

```

let rec nnf sign prop =
  match prop with
  | And (p1, p2) ->
    if sign then And (nnf sign p1, nnf sign p2)
    else Or (nnf sign p1, nnf sign p2)
  | Or (p1, p2) ->
    if sign then Or (nnf sign p1, nnf sign p2)
    else And (nnf sign p1, nnf sign p2)
  | Not p ->
    nnf (not sign) p
  | Var _ | True ->
    if sign then prop else Not prop

let NNF prop = nnf true prop

```

The following demonstrates that two terms have equivalent NNF normal forms:

---

```

> let t1 = Not(And(Not(Var("x")), Not(Var("y"))));;

val t1 : Prop = Prop 8

> fsi.AddPrinter(showProp 5);;
> t1;;

val it : Prop = not (not x && not y)

> let t2 = Or(Not(Not(Var("x"))),Var("y"));;

val t2 : Prop = not (not x) || y

> (t1 = t2);;

val it : bool = false

> NNF t1;;

val it : Prop = x || y

> NNF t2;;

val it : Prop = x || y

> NNF t1 = NNF t2;;

val it : bool = true

```

---

## Equality, Hashing, and Comparison for New Structured Data Types

### Equality, Hashing, and Comparison

Many efficient algorithms over structured data are built on primitives that efficiently compare and hash representations of information. In Chapter 5, you saw a number of predefined generic operations, including generic comparison, equality, and hashing, accessed via functions such as:

---

```

val compare : 'T -> 'T -> int when 'T : comparison
val (=) : 'T -> 'T -> bool when 'T : equality
val (<) : 'T -> 'T -> bool when 'T : comparison
val (<=) : 'T -> 'T -> bool when 'T : comparison
val (>) : 'T -> 'T -> bool when 'T : comparison
val (>=) : 'T -> 'T -> bool when 'T : comparison
val min : 'T -> 'T -> 'T when 'T : comparison

```

```
val max : 'T -> 'T -> 'T when 'T : comparison
val hash : 'T -> int when 'T : equality
```

---

First, note that these are *generic* operations—they can be used on objects of many different types. This can be seen by the use of 'T in the signatures of these operations. The operations take one or two parameters of the same type. For example, you can apply the = operator to two Form objects, or two System.DateTime objects, or two System.Type objects, and something reasonable happens. Some other important derived generic types, such as the immutable (persistent) Set<\_> and Map<\_,\_> types in the F# library, also use generic comparison on their key type:

```
type Set<'T when 'T : comparison> = ...
type Map<'Key, 'Value when 'Key : comparison> = ...
```

These operations and types are all *constrained*, in this case by the equality and/or comparison constraints. The purpose of constraints on type parameters is to make sure the operations are used only on a particular set of types. For example, consider equality and ordered comparison on a System.Windows.Forms.Form object. Equality is permitted, because the default for nearly all .NET object types is reference equality:

```
let form1 = new System.Windows.Forms.Form()
let form2 = new System.Windows.Forms.Form()
form1 = form1    // true
form1 = form2    // false
```

Ordered comparison isn't permitted, however:

```
let form1 = new System.Windows.Forms.Form()
let form2 = new System.Windows.Forms.Form()
form1 <= form2
error FS0001: The type 'Windows.Forms.Form' does not support the 'comparison' constraint. For example, it does not support the 'System.IComparable' interface
```

That's good! There is no natural ordering for form objects, or at least no ordering is provided by the .NET libraries.

Equality and comparison can work over the structure of types. For example, you can use the equality operators on a tuple only if the constituent parts of the tuple also support equality. This means that using equality on a tuple of forms is permitted:

---

```
> let form1 = new System.Windows.Forms.Form();;
> let form2 = new System.Windows.Forms.Form();;
> (form1, form2) = (form1, form2);;

val it : bool = true

> (form1, form2) = (form2, form1);;

val it : bool = false
```

---

But using ordered comparison of a tuple isn't:

---

```
> (form1, "Data for Form1") <= (form2, " Data for Form2");;
```

*error FS0001: The type 'Windows.Forms.Form' does not support the 'comparison' constraint. For example, it does not support the 'System.IComparable' interface*

---

Again, that's good—this ordering would be a bug in your code. Now, let's take a closer look at when equality and comparison constraints are satisfied in F#.

- The equality constraint is satisfied if the type definition doesn't have the `NoEquality` attribute, and any dependencies also satisfy the equality constraint.
- The comparison constraint is satisfied if the type definition doesn't have the `NoComparison` attribute, and the type definition implements `System.IComparable`, and any dependencies also satisfy the comparison constraint.

An equality constraint is relatively weak, because nearly all CLI types satisfy it. A comparison constraint is a stronger constraint, because it usually implies that a type must implement `System.IComparable`.

## Asserting Equality, Hashing, and Comparison Using Attributes

These attributes control the comparison and equality semantics of type definitions:

- `StructuralEquality` and `StructuralComparison`: Indicate that a structural type must support equality and comparison
- `NoComparison` and `NoEquality`: Indicate that a type doesn't support equality or comparison
- `CustomEquality` and `CustomComparison`: Indicate that a structural type supports custom equality and comparison

Let's look at examples of these. Sometimes you may want to assert that a structural type must support structural equality, and you want an error at the definition of the type if it doesn't. Do this by adding the `StructuralEquality` or `StructuralComparison` attribute to the type:

```
[<StructuralEquality; StructuralComparison>]  
type MiniIntegerContainer = MiniIntegerContainer of int
```

This adds extra checking. In the following example, the code gives an error at compile time—the type can't logically support automatic structural comparison, because one of the element types doesn't support ordered comparison:

```
[<StructuralEquality; StructuralComparison>]  
type MyData = MyData of int * string * string * System.Windows.Forms.Form
```

*error FS1177: The struct, record or union type 'MyData' has the 'StructuralComparison' attribute but the component type 'System.Windows.Forms.Form' does not satisfy the 'comparison' constraint*

## Fully Customizing Equality, Hashing, and Comparison on a Type

Many types in the .NET libraries come with custom equality, hashing, and comparison implementations. For example, `System.DateTime` has custom implementations of these.

F# also allows you to define custom equality, hashing, and comparison for new type definitions. For example, values of a type may carry a unique integer tag that can be used for this purpose. In such cases, we recommend that you take full control of your destiny and define custom comparison and equality operations on your type. For example, Listing 9-5 shows how to customize equality, hashing (using the predefined hash function), and comparison based on a unique stamp integer value. The type definition includes an implementation of `System.IComparable` and overrides of `Object.Equals` and `Object.GetHashCode`.

*Listing 9-5. Customizing equality, hashing, and comparison for a record type definition*

```

/// A type abbreviation indicating we're using integers for unique stamps
/// on objects
type stamp = int

/// A structural type containing a function that can't be compared for equality
[<CustomEquality; CustomComparison>]
type MyThing =
    {Stamp : stamp;
     Behaviour : (int -> int)}

    override x.Equals(yobj) =
        match yobj with
        | :? MyThing as y -> (x.Stamp = y.Stamp)
        | _ -> false

    override x.GetHashCode() = hash x.Stamp
    interface System.IComparable with
        member x.CompareTo yobj =
            match yobj with
            | :? MyThing as y -> compare x.Stamp y.Stamp
            | _ -> invalidArg "yobj" "cannot compare values of different types"

```

The `System.IComparable` interface is defined in the .NET libraries:

```

namespace System

    type IComparable =
        abstract CompareTo : obj -> int

```

Recursive calls to compare subexpressions are processed using the functions:

---

```

val hash : 'T -> int when 'T : equality
val (=) : 'T -> 'T -> bool when 'T : equality
val compare : 'T -> 'T -> int when 'T : comparison

```

---

Listing 9-6 shows the same for a union type, this time using some helper functions.

*Listing 9-6. Customizing generic hashing and comparison on a union type*

```

let inline equalsOn f x (yobj : obj) =
    match yobj with
    | :? 'T as y -> (f x = f y)
    | _ -> false

let inline hashOn f x = hash (f x)

let inline compareOn f x (yobj : obj) =
    match yobj with
    | :? 'T as y -> compare (f x) (f y)
    | _ -> invalidArg "yobj" "cannot compare values of different types"

type stamp = int

[<CustomEquality; CustomComparison>]
type MyUnionType =
    | MyUnionType of stamp * (int -> int)

    static member Stamp (MyUnionType (s, _)) = s

    override x.Equals y = equalsOn MyUnionType.Stamp x y
    override x.GetHashCode() = hashOn MyUnionType.Stamp x
    interface System.IComparable with
        member x.CompareTo y = compareOn MyUnionType.Stamp x y

```

Listing 9-6 also shows how to implement the `System.Object` method `GetHashCode`. This follows the same pattern as generic equality.

Finally, you can declare that a structural type should use reference equality:

```

[<ReferenceEquality>]
type MyFormWrapper = MyFormWrapper of System.Windows.Forms.Form * (int -> int)

```

There is no such thing as reference comparison (the object pointers used by .NET move around, so the ordering would change). You can implement that by using a unique tag and custom comparison.

## Suppressing Equality, Hashing, and Comparison on a Type

You can suppress equality on an F# defined type by using the `NoEquality` attribute on the definition of the type. This means the type isn't considered to satisfy the equality constraint. Likewise, you can suppress comparison on an F# defined type by using the `NoComparison` attribute on the definition of the type:

```

[<NoEquality; NoComparison>]
type MyProjections =
    | MyProjections of (int * string) * (string -> int)

```

Adding these attributes to your library types makes client code safer, because it's less likely to inadvertently rely on equality and comparison over types for which these operations make no sense.

## Customizing Generic Collection Types

Programmers love defining new generic collection types. This is done less often in .NET and F# programming than in other languages, because the F# and .NET built-in collections are so good, but it's still important.

Equality and comparison play a role here. For example, it's common to have collections in which some of the values can be indexed using hashing, compared for equality when searching, or compared using an ordering. For example, seeing a constraint on this signature on a library type would come as no surprise:

```
type Graph<'Node when 'Node : equality>() = ...
```

The presence of the constraint is somewhat reassuring, because the requirement on node types is made clearer. Sometimes it's also desirable to be able to compare entire containers: for example, to compare one set with another, one map with another, or one graph with another. Consider the simplest generic collection type of all, which holds only one element. You can define it easily in F#:

```
type MiniContainer<'T> = MiniContainer of 'T
```

In this case, this is a structural type definition, and F# infers that there is an equality and comparison dependency on 'T. All done! You can use `MiniContainer<_>` with values of any type, and you can do equality and comparison on `MiniContainer` values only if the element type also supports equality and comparison. Perfect.

If `MiniContainer` is a class type or has customized comparison and equality logic, however, then you need to be more explicit about dependencies. You can declare dependencies by using the `EqualityConditionalOn` and `ComparisonConditionalOn` attributes on the type parameter. You should also use the operators `Unchecked.equals`, `Unchecked.hash`, and `Unchecked.compare` to process elements recursively. With these attributes, `MiniContainer<A>` satisfies the equality and comparison constraints if `A` satisfies these constraints. Here's a full example:

```
type MiniContainer<[<EqualityConditionalOn; ComparisonConditionalOn >]'T>(x : 'T) =
    member x.Value = x
    override x.Equals(yobj) =
        match yobj with
        | :? MiniContainer<'T> as y -> Unchecked.equals x.Value y.Value
        | _ -> false

    override x.GetHashCode() = Unchecked.hash x.Value

interface System.IComparable with
    member x.CompareTo yobj =
        match yobj with
        | :? MiniContainer<'T> as y -> Unchecked.compare x.Value y.Value
        | _ -> invalidArg "yobj" "cannot compare values of different types"
```

---

■ **Note:** Be careful about using generic equality, hashing, and comparison on mutable data. Changing the value of a field may change the value of the hash or the results of the operation. It's normally better to use the operations on immutable data or data with custom implementations.

---

## Tail Calls and Recursive Programming

In the previous section, you saw how to process tree-structured using recursive functions. In this section, you learn about important topics associated with programming with recursive functions: stack usage and tail-calls.

When F# programs execute, two resources are managed automatically, *stack*- and *heap*-allocated memory. Stack space is needed every time you call an F# function and is reclaimed when the function returns or when it performs a *tail call*. It's perhaps surprising that stack space is more limited than space in the garbage-collected heap. For example, on a 32-bit Windows machine, the default settings are such that each thread of a program can use up to 1MB of stack space. Because stack is allocated every time a function call is made, a very deep series of nested function calls causes a `StackOverflowException` to be raised. For example, on a 32-bit Windows machine, the following program causes a stack overflow when `n` reaches about 79000:

```
let rec deepRecursion n =
    if n = 1000000 then () else
    if n % 100 = 0 then
        printfn "--> deepRecursion, n = %d" n
    deepRecursion (n+1)
    printfn "<-- deepRecursion, n = %d" n
```

You can see this in F# Interactive:

---

```
> deepRecursion 0;;

--> deepRecursion, n = 0
...
--> deepRecursion, n = 79100
--> deepRecursion, n = 79200
--> deepRecursion, n = 79300
Process is terminated due to StackOverflowException
Session termination detected. Press Enter to restart.
```

---

Stack overflows are extreme exceptions, because it's often difficult to recover correctly from them. For this reason, it's important to ensure that the amount of stack used by your program doesn't grow in an unbounded fashion as your program proceeds, especially as you process large inputs. Furthermore, deep stacks can hurt in other ways; for example, the .NET garbage collector traverses the entire stack on every garbage collection. This can be expensive if your stacks are very deep.

Because recursive functions are common in F# functional programming, this may seem to be a major problem. There is, however, one important case in which a function call recycles stack space eagerly: a *tail call*. A tail call is any call that is the last piece of work done by a function. For example, Listing 9-7 shows the same program with the last line deleted.

### Listing 9-7. A simple tail-recursive function

```
let rec tailCallRecursion n : unit =
    if n = 1000000 then () else
    if n % 100 = 0 then
        printfn "--> tailCallRecursion, n = %d" n
    tailCallRecursion (n+1)
```



The code now runs to completion without a problem:

---

```
> tailCallRecursion 0;;
...
--> tailCallRecursion, n = 999600
--> tailCallRecursion, n = 999700
--> tailCallRecursion, n = 999800
--> tailCallRecursion, n = 999900
```

---

When a tail call is made, the .NET Common Language Runtime can drop the current stack frame before executing the target function, rather than waiting for the call to complete. Sometimes this optimization is performed by the F# compiler. If the `n = 1000000` check were removed in the previous program, the program would run indefinitely. (Note that `n` would cycle around to the negative numbers, because arithmetic is unchecked for overflow unless you open the module `Microsoft.FSharp.Core.Operators.Checked`.)

Functions such as `tailCallRecursion` are known as *tail-recursive* functions. When you write recursive functions, you should check either that they're tail recursive or that they won't be used with inputs that cause them to recurse to an excessive depth. The following sections give some examples of techniques you can use to make your functions tail recursive.

## Tail Recursion and List Processing

Tail recursion is particularly important when you're processing F# lists, because lists can be long and recursion is the natural way to implement many list-processing functions. For example, here is a function to find the last element of a list (this must traverse the entire list, because F# lists are pointers to the head of the list):

```
let rec last l =
    match l with
    | [] -> invalidArg "l" "the input list should not be empty"
    | [h] -> h
    | h::t -> last t
```

This function is tail recursive, because no work happens after the recursive call `last t`. Many list functions are written most naturally in non-tail-recursive ways, however. Although it can be a little annoying to write these functions using tail recursion, it's often better to use tail recursion than to leave the potential for stack overflow lying around your code. For example, the following function creates a list of length `n` in which every entry in the list is the value `x`:

```
let rec replicateNotTailRecursiveA n x =
    if n <= 0 then []
    else x :: replicateNotTailRecursiveA (n - 1) x
```

The problem with this function is that work is done after the recursive call. This becomes obvious when you write the function in this fashion:

```
let rec replicateNotTailRecursiveB n x =
    if n <= 0 then []
    else
        let recursiveResult = replicateNotTailRecursiveB (n - 1) x
        x :: recursiveResult
```

Clearly, a value is being constructed by the expression `x :: recursiveResult` after the recursive call `replicateNotTailRecursiveB (n-1) x`. This means that the function isn't tail recursive. The solution is to write the function using an *accumulating parameter*. This is often done by using an auxiliary function that accepts the accumulating parameter:

```
let rec replicateAux n x acc =
    if n <= 0 then acc
    else replicateAux (n - 1) x (x :: acc)

let replicate n x = replicateAux n x []
```

Here, the recursive call to `replicateAux` is tail recursive. Sometimes the auxiliary functions are written as inner recursive functions:

```
let replicate n x =
    let rec loop i acc =
        if i >= n then acc
        else loop (i + 1) (x :: acc)
    loop 0 []
```

The F# compiler optimizes inner recursive functions such as these to produce an efficient pair of functions that pass extra arguments as necessary.

When you're processing lists, accumulating parameters often accumulate a list in reverse order. This means a call to `List.rev` may be required at the end of the recursion. For example, consider this implementation of `List.map`, which isn't tail recursive:

```
let rec mapNotTailRecursive f inputList =
    match inputList with
    | [] -> []
    | h :: t -> (f h) :: mapNotTailRecursive f t
```

Here is an implementation that neglects to reverse the accumulating parameter:

```
let rec mapIncorrectAcc f inputList acc =
    match inputList with
    | [] -> acc // whoops! Forgot to reverse the accumulator here!
    | h :: t -> mapIncorrectAcc f t (f h :: acc)
```

```
let mapIncorrect f inputList = mapIncorrectAcc f inputList []
```

---

```
> mapIncorrect (fun x -> x * x) [1; 2; 3; 4];;
```

```
val it : int list = [16; 9; 4; 1]
```

---

Here is a correct implementation:

```
let rec mapAcc f inputList acc =
    match inputList with
    | [] -> List.rev acc
```

```

    | h::t -> mapAcc f t (f h :: acc)

let map f inputList = mapAcc f inputList []

> map (fun x -> x * x) [1; 2; 3; 4];;

val it : int list = [1; 4; 9; 16]

```

## Tail Recursion and Object-Oriented Programming

You often need to implement object members with a tail-recursive implementation. For example, consider this list-like data structure:

```

type Chain =
    | ChainNode of int * string * Chain
    | ChainEnd of string

member chain.LengthNotTailRecursive =
    match chain with
    | ChainNode(_, _, subChain) -> 1 + subChain.LengthNotTailRecursive
    | ChainEnd _ -> 0

```

The implementation of `LengthNotTailRecursive` is *not* tail recursive, because the addition `1 +` applies to the result of the recursive property invocation. One obvious tail-recursive implementation uses a local recursive function with an accumulating parameter, as shown in Listing 9-8.

### *Listing 9-8. Making an object member tail recursive*

```

type Chain =
    | ChainNode of int * string * Chain
    | ChainEnd of string

// The implementation of this property is tail recursive.
member chain.Length =
    let rec loop c acc =
        match c with
        | ChainNode(_, _, subChain) -> loop subChain (acc + 1)
        | ChainEnd _ -> acc
    loop chain 0

```

---

■ **Note:** The list-processing functions in the F# library module `Microsoft.FSharp.Collections.List` are tail recursive, except where noted in the documentation. Some of them have implementations that are specially optimized to take advantage of the implementation of the `list` data structure.

---

## Tail Recursion and Processing Unbalanced Trees

This section considers tail-recursion problems that are much less common in practice but for which it's important to know the techniques to apply if required. The techniques also illustrate some important aspects of functional programming—in particular, an advanced technique called *continuation passing*.

Tree-structured data are generally more difficult to process in a tail-recursive way than list-structured data. For example, consider this tree structure:

```
type Tree =
  | Node of string * Tree * Tree
  | Tip of string

let rec sizeNotTailRecursive tree =
  match tree with
  | Tip _ -> 1
  | Node(_, treeLeft, treeRight) ->
      sizeNotTailRecursive treeLeft + sizeNotTailRecursive treeRight
```

The implementation of this function isn't tail recursive. Luckily, this is rarely a problem, especially if you can assume that the trees are *balanced*. A tree is balanced when the depth of each subtree is roughly the same. In that case, a tree of depth 1,000 will have about 21,000 entries. Even for a balanced tree of this size, the recursive calls to compute the overall size of the tree won't recurse to a depth greater than 1,000—not deep enough to cause stack overflow except when the routine is being called by some other function already consuming inordinate amounts of stack. Many data structures based on trees are balanced by design; for example, the Set and Map data structures implemented in the F# library are based on balanced binary trees.

Some trees can be unbalanced, however. For example, you can explicitly make a highly unbalanced tree:

```
let rec mkBigUnbalancedTree n tree =
  if n = 0 then tree
  else Node("node", Tip("tip"), mkBigUnbalancedTree (n - 1) tree)

let tree1 = Tip("tip")
let tree2 = mkBigUnbalancedTree 15000 tree1
let tree3 = mkBigUnbalancedTree 15000 tree2
let tree4 = mkBigUnbalancedTree 15000 tree3
let tree5 = mkBigUnbalancedTree 15000 tree4
let tree6 = mkBigUnbalancedTree 15000 tree5
```

Calling `sizeNotTailRecursive(tree6)` now risks a stack overflow (note that this may depend on the amount of memory available on a system; change the size of the tree to force the stack overflow). You can solve this in part by trying to predict whether the tree will be unbalanced to the left or the right and by using an accumulating parameter:

```
let rec sizeAcc acc tree =
  match tree with
  | Tip _ -> 1 + acc
  | Node(_, treeLeft, treeRight) ->
      let acc = sizeAcc acc treeLeft
      sizeAcc acc treeRight
```

```
let size tree = sizeAcc 0 tree
```

This algorithm works for `tree6`, because it's biased toward accepting trees that are skewed to the right. The recursive call that processes the right branch is a tail call, which the call that processes the left branch isn't. This may be OK if you have prior knowledge of the shape of your trees. This algorithm still risks a stack overflow, however, and you may have to change techniques. One way to do this is to use a much more general and important technique known as *continuation passing*.

## Using Continuations to Avoid Stack Overflows

A continuation is a function that receives the result of an expression after it's been computed. Listing 9-9 shows an example implementation of the previous algorithm that handles trees of arbitrary size.

**Listing 9-9.** Making a function tail recursive via an explicit continuation

```
let rec sizeCont tree cont =
  match tree with
  | Tip _ -> cont 1
  | Node(_, treeLeft, treeRight) ->
    sizeCont treeLeft (fun leftSize ->
      sizeCont treeRight (fun rightSize ->
        cont (leftSize + rightSize)))

let size tree = sizeCont tree (fun x -> x)
```

What's going on here? Let's look at the type of `sizeCont` and `size`:

---

```
val sizeCont : tree:Tree -> cont:(int -> 'a) -> 'a
val size : tree:Tree -> int
```

---

The type of `sizeCont tree cont` can be read as “compute the size of the tree and call `cont` with that size.” If you look at the type of `sizeCont`, you can see that it will call the second parameter of type `int -> 'T` at some point—how else could the function produce the final result of type `'T`? When you look at the implementation of `sizeCont`, you can see that it does call `cont` on both branches of the match.

Now, if you look at recursive calls in `sizeCont`, you can see that they're both tail calls:

```
sizeCont treeLeft (fun leftSize ->
  sizeCont treeRight (fun rightSize ->
    cont (leftSize + rightSize)))
```

That is, the first call to `sizeCont` is a tail call with a new continuation, as is the second. The first continuation is called with the size of the left tree, and the second is called with the size of the right tree. Finally, you add the results and call the original continuation `cont`. Calling `size` on an unbalanced tree such as `tree6` now succeeds:

---

```
> size tree6;;

val it : int = 50001
```

---

How did you turn a tree walk into a tail-recursive algorithm? The answer lies in the fact that continuations are function objects, which are allocated on the garbage-collected heap. Effectively, you've generated a work list represented by objects, rather than keeping a work list via a stack of function invocations.

As it happens, using a continuation for both the right and left trees is overkill, and you can use an accumulating parameter for one side. This leads to a more efficient implementation, because each continuation-function object is likely to involve one allocation (short-lived allocations such as continuation objects are very cheap but not as cheap as not allocating at all!). For example, Listing 9-10 shows a more efficient implementation.

*Listing 9-10. Combining an accumulator with an explicit continuation*

```
let rec sizeContAcc acc tree cont =
  match tree with
  | Tip _ -> cont (1 + acc)
  | Node (_, treeLeft, treeRight) ->
    sizeContAcc acc treeLeft (fun accLeftSize ->
      sizeContAcc accLeftSize treeRight cont)

let size tree = sizeContAcc 0 tree (fun x -> x)
```

The behavior of this version of the algorithm is:

1. You start with an accumulator `acc` of 0.
2. You traverse the left spine of the tree until a `Tip` is found, building up a continuation for each `Node` along the way.
3. When a `Tip` is encountered, the continuation from the previous `Node` is called with `accLeftSize` increased by 1. The continuation makes a recursive call to `sizeContAcc` for its right tree, passing the continuation for the second-to-last node along the way.
4. When all is done, all the left and right trees have been explored, and the final result is delivered to the `(fun x -> x)` continuation.

As you can see from this example, continuation passing is a powerful control construct, although it's used only occasionally in F# programming.

## Another Example: Processing Syntax Trees

One real-world example where trees may become unbalanced is syntax trees for parsed languages when the inputs are very large and machine generated. In this case, some language constructs may be repeated very large numbers of times in an unbalanced way. For example, consider this data structure:

```
type Expr =
  | Add of Expr * Expr
  | Bind of string * Expr * Expr
  | Var of string
  | Num of int
```

This data structure would be suitable for representing arithmetic expressions of the forms *var*, *expr + expr*, and *bind var = expr in expr*. This chapter and Chapter 11 are dedicated to techniques for representing

and processing languages of this kind. As with all tree structures, most traversal algorithms over this type of abstract syntax trees aren't naturally tail recursive. For example, here is a simple evaluator:

```
type Env = Map<string, int>

let rec eval (env : Env) expr =
    match expr with
    | Add (e1, e2) -> eval env e1 + eval env e2
    | Bind (var, rhs, body) -> eval (env.Add(var, eval env rhs)) body
    | Var var -> env.[var]
    | Num n -> n
```

The recursive call `eval env rhs` isn't tail recursive. For the vast majority of applications, you never need to worry about making this algorithm tail recursive. Stack overflow may be a problem, however, if bindings are nested to great depth, such as in `bind v1 = (bind v2 = ... (bind v1000000 = 1. . .)) in v1+v1`. If the syntax trees come from human-written programs, you can safely assume this won't be the case. If you need to make the implementation tail recursive, however, you can use continuations, as shown in Listing 9-11.

**Listing 9-11.** *A tail-recursive expression evaluator using continuations*

```
let rec evalCont (env : Env) expr cont =
    match expr with
    | Add (e1, e2) ->
        evalCont env e1 (fun v1 ->
            evalCont env e2 (fun v2 ->
                cont (v1 + v2)))
    | Bind (var, rhs, body) ->
        evalCont env rhs (fun v1 ->
            evalCont (env.Add(var, v1)) body cont)
    | Num n ->
        cont n
    | Var var ->
        cont (env.[var])

let eval env expr = evalCont env expr (fun x -> x)
```

---

■ **Note:** Programming with continuations can be tricky, and you should use them only when necessary, or use the F# `async` type as a way of managing continuation-based code. Where possible, abstract the kind of transformation you're doing on your tree structure (for example, a map, fold, or bottom-up reduction) so you can concentrate on getting the traversal right. In the previous examples, the continuations all effectively play the role of a *work list*. You can also reprogram your algorithms to use work lists explicitly and to use accumulating parameters for special cases. Sometimes this is necessary to gain maximum efficiency, because an array or a queue can be an optimal representation of a work list. When you make a work list explicit, the implementation of an algorithm becomes more verbose, but in some cases, debugging can become simpler.

---

## Summary

This chapter covered some of the techniques you're likely to use in your day-to-day F# programming when working with *sequences* and *structured data*. Nearly all the remaining chapters use some of the techniques described in this chapter, and Chapter 12 goes deeper into symbolic programming based on structured-data programming techniques.

In the next chapter, you'll learn about programming techniques for another fundamental kind of data: programming with numeric data using structural and statistical methods.



## CHAPTER 10



# Numeric Programming and Charting

In Chapters 8 and 9, you learned constructs and techniques for programming with three important kinds of data in F#: *textual data*, *sequences of data*, and *structured data*. In this chapter, we return to constructs and techniques for one of the most important kinds of data in all programming systems: *numeric data*.

Programming with numbers is a huge topic, ultimately overlapping with many fields of mathematics, statistics, and computer science, and highly related to applied science, engineering, economics, and finance. In this chapter, you learn about:

- Programming with additional basic numeric types and literals beyond simple “integers” and “floating point” numbers already covered in Chapter 3
- Using library and hand-coded routines for *summing*, *aggregating*, *maximizing*, and *minimizing* sequences
- Some simple algorithmic programming with F#, implementing the KMeans clustering algorithm and applying it to some input data
- Some *charting* with F#, using the FSharpChart library
- Using the Math.NET library for *statistics*, *distributions*, and *linear algebra*
- Using the unique F# feature *units of measure* for giving strong types to numeric data

This chapter makes extensive reference to the Math.NET open-source math library. You can find out more about Math.NET at <http://www.mathdotnet.com/>.

## Basic Charting with FSharpChart

Your primary focus in this chapter is on numeric programming itself. A very common activity associated with working with numbers is *charting*. You will now explore some basic charting using the FSharpChart charting library, available by searching for “FSharpChart” on the Web.

FSharpChart is very easy to get going with. For example, consider creating 1,000 random points and plotting them:

```
#load "FSharpChart.fsx"  
open MSDN.FSharp.Charting
```

```

let rnd = System.Random()
let rand() = rnd.NextDouble()

let randomPoints = [for i in 0 .. 1000 -> 10.0 * rand(), 10.0 * rand()]

randomPoints |> FSharpChart.Point

```

This gives the chart:

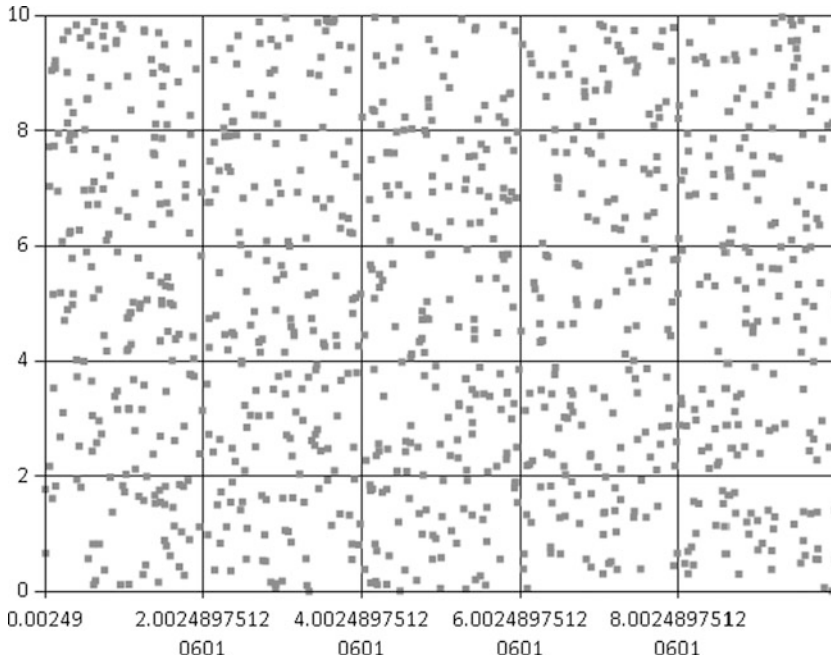

Likewise, consider two sinusoidal data sets with some random noise added.

```

let randomTrend1 = [for i in 0.0 .. 0.1 .. 10.0 -> i, sin i + rand()]
let randomTrend2 = [for i in 0.0 .. 0.1 .. 10.0 -> i, sin i + rand()]

```

You can combine two charts – the first data set as a line, and the second as a set of points – as follows:

```

type Chart = FSharpChart
Chart.Combine [Chart.Line randomTrend1; Chart.Point randomTrend2]

```

Giving:

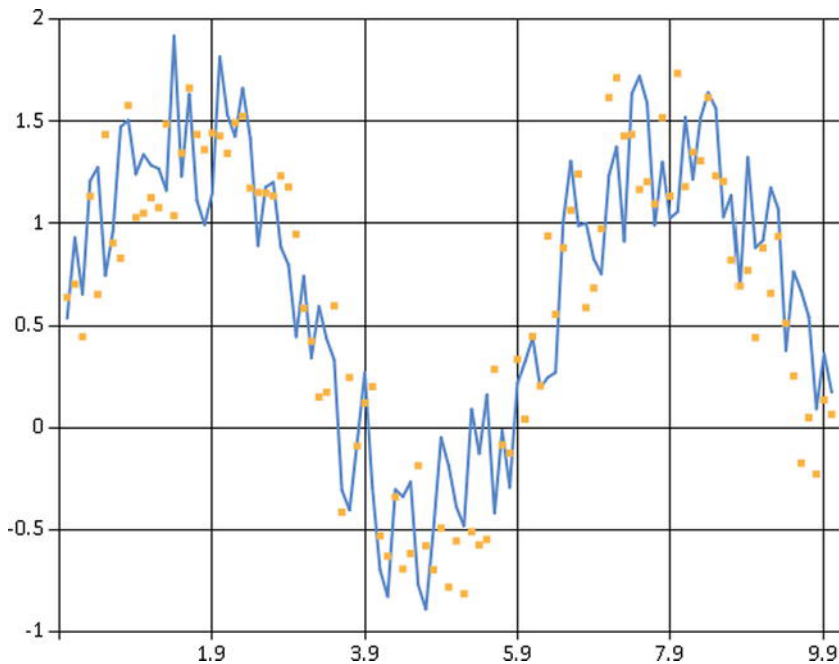

Many other chart types and options are available for use with FSharpChart. For example, you can add a title to your chart:

```
Chart.Line (randomPoints,Title="Expected Trend")
```

Charting is often used with pipelining, so attributes like this are often specified using “|> fun c ->” as follows:

```
randomPoints
  |> fun c -> Chart.Line (c,Title="Expected Trend")
```

## Basic Numeric Types and Literals

We first cover the most common base types of data manipulated in F# code, beginning with the basics of F# arithmetic. Table 10-1 lists the basic numeric types used in F# code and their corresponding literal forms. The table also lists the non-numeric types `bool` and `unit`.

*Table 10-1. Basic Types and Literals*

Type	Description	Sample Literals	Long Name
<code>bool</code>	True/false values	<code>true</code> , <code>false</code>	<code>System.Boolean</code>
<code>byte</code>	8-bit unsigned integers	<code>0uy</code> , <code>19uy</code> , <code>0xFFuy</code>	<code>System.Byte</code>
<code>sbyte</code>	8-bit signed integers	<code>0y</code> , <code>19y</code> , <code>0xFFy</code>	<code>System.SByte</code>
<code>int16</code>	16-bit signed integers	<code>0s</code> , <code>19s</code> , <code>0x0800s</code>	<code>System.Int16</code>
<code>uint16</code>	16-bit unsigned integers	<code>0us</code> , <code>19us</code> , <code>0x0800us</code>	<code>System.UInt16</code>

Type	Description	Sample Literals	Long Name
int, int32	32-bit signed integers	0, 19, 0x0800, 0b0001	System.Int32
uint32	32-bit unsigned integers	0u, 19u, 0x0800u	System.UInt32
int64	64-bit signed integers	0L, 19L, 0x0800L	System.Int64
uint64	64-bit unsigned integers	0UL, 19UL, 0x0800UL	System.UInt64
nativeint	Machine-sized signed integers	0n, 19n, 0x0800n	System.IntPtr
unativeint	Machine-sized unsigned integers	0un, 19un, 0x0800un	System.UIntPtr
single, float32	32-bit IEEE floating-point	0.0f, 19.7f, 1.3e4f	System.Single
double, float	64-bit IEEE floating-point	0.0, 19.7, 1.3e4	System.Double
decimal	High-precision decimal values	0M, 19M, 19.03M	System.Decimal
bigint	Arbitrarily large integers	0I, 19I	System.Numerics. BigInteger
complex	Complex numbers based on 64-bit floating point numbers	Complex(2.0, 3.0)	System.Numerics. Complex

## Arithmetic Operators

Table 10-2 lists the most commonly used arithmetic operators. These are overloaded to work with all the numeric types listed in Table 10-1.

*Table 10-2. Arithmetic Operators and Examples*

Operator	Description	Sample Use on int	Sample Use on float
+	Unchecked addition	1 + 2	1.0 + 2.0
-	Unchecked subtraction	12 - 5	12.3 - 5.4
*	Unchecked multiplication	2 * 3	2.4 * 3.9
/	Division	5 / 2	5.0 / 2.0
%	Modulus	5 % 2	5.4 % 2.0
-	Unary negation	-(5+2)	-(5.4+2.4)

## Checked Arithmetic

The behavior of these and other operators can be extended for user-defined types, a topic covered in Chapter 6. In F#, addition, subtraction, and multiplication over integers are unchecked; that is, if overflow or underflow occur beyond the representable range, wraparound occurs. For example, 2147483647 is the largest representable 32-bit integer of the int type:

```
> 2147483647 + 1;;
```

```
val it : int = -2147483648
```

You can access checked versions of arithmetic operators that raise `System.OverflowException` exceptions by opening the `Microsoft.FSharp.Core.Operators.Checked` module. If avoiding overflow is a priority, using the `decimal`, `bigint`, and `bignum` types is recommended. Division by zero raises a `System.`

`DivideByZeroException` exception, except in the case of floating-point numbers, in which it returns one of the special floating-point numbers `Infinity`, `-Infinity` and `NaN`. Operator overloading interacts with type inference—if a use of an overloaded operator isn't otherwise constrained to work on a particular type, F# assumes it works on 32-bit integers.

## Arithmetic Conversions

Numeric types aren't implicitly converted—conversions among different numeric types must be made explicitly. You do this by using overloaded conversion operators. These work the same way as overloaded infix operators such as `+` and `*`. Table 10-3 shows the primary conversion operators.

*Table 10-3. Overloaded Arithmetic Conversions and Examples*

Operator	Description	Sample Use	Result
<code>sbyte</code>	Convert/truncate to <code>sbyte</code>	<code>sbyte (-17)</code>	<code>-17y</code>
<code>byte</code>	Convert/truncate to <code>byte</code>	<code>byte 255</code>	<code>255uy</code>
<code>int16</code>	Convert/truncate to <code>int16</code>	<code>int16 0</code>	<code>0s</code>
<code>uint16</code>	Convert/truncate to <code>uint16</code>	<code>uint16 65535</code>	<code>65535us</code>
<code>int/int32</code>	Convert/truncate to <code>int32</code>	<code>int 17.8</code>	<code>17</code>
<code>uint32</code>	Convert/truncate to <code>uint32</code>	<code>uint32 12</code>	<code>12u</code>
<code>int64</code>	Convert/truncate to <code>int64</code>	<code>int64 (-100.4)</code>	<code>-100L</code>
<code>uint64</code>	Convert/truncate to <code>uint64</code>	<code>uint64 1</code>	<code>1UL</code>
<code>decimal</code>	Convert to <code>decimal</code>	<code>decimal 65.3</code>	<code>65.3M</code>
<code>float32</code>	Convert to <code>float32/single</code>	<code>float32 65</code>	<code>65.0f</code>
<code>float</code>	Convert to <code>float/double</code>	<code>float 65</code>	<code>65.0</code>

These conversions are all unchecked in the sense that they won't raise exceptions. Again, the `Microsoft.FSharp.Core.Operators.Checked` module has corresponding definitions of these operators. An alternative is to use the library static methods contained in the type `System.Convert`, such as `System.Convert.ToDouble()`. These do perform checking, which means they raise an exception if the source number can't be represented within the numeric range of the target type. As with many object-oriented library constructs, uses of `System.Convert` methods may require type annotations to resolve overloading, which is discussed in Chapters 5 and 6.

## Arithmetic Comparisons

When used with numeric values, the binary comparison operators `=`, `<>`, `<`, `<=`, `>`, `>=`, `min`, and `max` perform comparisons according to the natural ordering for each particular numeric type. You can also use these operators on other data types, such as to compare lists of integers, and you can customize their behavior for new types you define. Chapter 5 discusses generic comparison in detail, and Chapter 8 discusses customizing generic comparison.

When used with floating-point values, these operators implement the IEEE semantics for `NaN` (Not a Number) values. For example, `(NaN = NaN)` is false, as are `(NaN <= NaN)` and `(NaN < NaN)`.

## Overloaded Math Functions

The module `Microsoft.FSharp.Core.Operators` includes the definition of a number of useful overloaded math operators. These are shown in Table 10-4 and are overloaded either on a suitable range of integer types or on the basic floating-point types.

*Table 10-4. Overloaded Math Functions and Examples*

Function	Description	Sample Use	Result
<code>abs</code>	Absolute value of signed numeric types	<code>abs (-10.0f)</code>	10.0f
<code>cos</code> , <code>sin</code> , <code>tan</code>	Trigonometric functions	<code>cos 0.0</code>	1.0
<code>cosh</code> , <code>sinh</code> , <code>tanh</code>	Hyperbolic trigonometric functions	<code>cosh 1.0</code>	1.543080635
<code>acos</code> , <code>asin</code> , <code>atan</code> , <code>atan2</code>	Inverse trigonometric functions	<code>acos 1.0</code>	0.0
<code>ceil</code> , <code>floor</code>	Round up, round down	<code>ceil 1.001</code>	2.0
<code>truncate</code>	Round toward zero	<code>truncate 8.9</code>	8.0
<code>exp</code> , <code>log</code> , <code>log10</code>	Exponent, logarithm, base-10 logarithm	<code>exp 1.0</code>	2.718281828
<code>( ** )</code>	Power	<code>2.0 ** 4.0</code>	16.0

## Bitwise Operations

All the integer types listed in Table 10-1 support bitwise manipulations on their underlying representations. Table 10-5 shows the bitwise manipulation operators.

*Table 10-5. Bitwise Arithmetic Operators and Examples*

Operator	Description	Sample Use	Result
<code>&amp;&amp;&amp;</code>	Bitwise “and”	<code>0x65 &amp;&amp;&amp; 0x0F</code>	0x05
<code>   </code>	Bitwise “or”	<code>0x65     0x18</code>	0x7D
<code>^^^</code>	Bitwise “exclusive or”	<code>0x65 ^^^ 0x0F</code>	0x6A
<code>~~~</code>	Bitwise negation	<code>~~~0x65</code>	0xFFFFFFFF9a
<code>&lt;&lt;&lt;</code>	Left shift	<code>0x01 &lt;&lt;&lt; 3</code>	0x08
<code>&gt;&gt;&gt;</code>	Right shift (arithmetic if signed)	<code>0x65 &gt;&gt;&gt; 3</code>	0x0C

The following sample shows how to use these operators to encode 32-bit integers into 1, 2, or 5 bytes, represented by returning a list of integers. Integers in the range 0 to 127 return a list of length 1:

```
let encode (n : int32) =
    if (n >= 0 && n <= 0x7F) then [n]
    elif (n >= 0x80 && n <= 0x3FFF) then
        [(0x80 ||| (n >>> 8)) &&& 0xFF;
         (n &&& 0xFF)]
    else [0xC0;
          ((n >>> 24) &&& 0xFF);
          ((n >>> 16) &&& 0xFF);
          ((n >>> 8) &&& 0xFF);
          (n &&& 0xFF)]
```

Here's an example of the function in action:

---

```
> encode 32;;

val it : int32 list = [32]

> encode 320;;

val it : int32 list = [129; 64]

> encode 32000;;

val it : int32 list = [192; 0; 0; 125; 0]
```

---

## Sequences, Statistics and Numeric Code

Some of the most common and simplest numerical programming techniques with F# involves taking aggregate statistics over sequences of objects. In this section, you learn how to use the built-in aggregation operators, such as `Seq.sum` and `Seq.averageBy`. Further, you look at how to define additional functions with similar characteristics. In later sections, you learn how to use functionality from the `Math.NET` library to perform more advanced statistical analysis of sequences of numbers.

### Summing, Averaging, Maximizing and Minimizing Sequences

The table below shows how to compute the average, sum, maximum, and minimums over input sequences using operations from the `Seq` module to process the data.

```
data |> Seq.average
data |> Seq.sum
data |> Seq.max
data |> Seq.min
data |> Seq.averageBy (fun x -> proj)
data |> Seq.sumBy (fun x -> proj)
data |> Seq.maxBy (fun x -> proj)
data |> Seq.minBy (fun x -> proj)
```

For example, consider taking the average, sum, maximum, and minimum of a set of 1,000 numbers between 0 and 1, each generating by multiplying two random numbers drawn from a random-number generator.

```
let rnd = new System.Random()
let rand() = rnd.NextDouble()
let data = [for i in 1 .. 1000 -> rand() * rand()]
```

```
let averageOfData = data |> Seq.average
let sumOfData = data |> Seq.sum
let maxOfData = data |> Seq.max
let minOfData = data |> Seq.min
```

The results are:

---

```
// Random numbers, results may differ!
val averageOfData : float = 0.2365092084
val sumOfData : float = 236.5092084
val maxOfData : float = 0.9457838635
val minOfData : float = 6.153537535e-05
```

---

As expected, the average of the sequence lies near 0.25.

Normally, however, statistics are generated by projecting information from particular objects using operators such as `Seq.sumBy`. For example, consider taking the average X, Y, and Z positions of a random set of 1,000 points drawn in three dimensions:

```
type RandomPoint = {X : float; Y : float; Z : float}

let random3Dpoints =
    [for i in 1 .. 1000 -> {X = rand(); Y = rand(); Z = rand()}]

let averageX = random3Dpoints |> Seq.averageBy (fun p -> p.X)
let averageY = random3Dpoints |> Seq.averageBy (fun p -> p.Y)
let averageZ = random3Dpoints |> Seq.averageBy (fun p -> p.Z)
```

As expected, the results center around 0.5:

---

```
// Random numbers, results may differ!
val averageX : float = 0.4910144491
val averageY : float = 0.5001688922
val averageZ : float = 0.5170302648
```

---

Likewise, you can use `Seq.maxBy` to determine the element where a maximum occurs for a particular measure:

```
let maxY = random3Dpoints |> Seq.maxBy (fun p -> p.Y)
```

This operator returns the object that corresponds to the maximum:

---

```
// Random numbers, results may differ!
val maxY : RandomPoint = {X = 0.9829979292;
                        Y = 0.9997189497;
                        Z = 0.4552816481;}
```

---

Likewise, you can use `minimize` and `maximize` by other measures. For example, consider finding the point that minimizes the distance from the origin to the point:

```
let norm (p : RandomPoint) = sqrt (p.X * p.X + p.Y * p.Y + p.Z * p.Z)
let closest = random3Dpoints |> Seq.minBy (fun p -> norm p)
```

As expected, the point has relatively low values for all of X, Y, and Z:

---

```
// Random numbers, results may differ!
val norm : p:RandomPoint -> float
val closest : RandomPoint = {X = 0.05287901873;
```



```
Y = 0.0570056001;
Z = 0.1018355787;}
```

Note that `Seq.maxBy` and `Seq.minBy` return the input object that maximizes/minimizes the function respectively—that is, they return the *input object* and not the *maximum/minimum* value. Some other similar operations in the F# libraries and .NET framework return the value itself—the type signature of the operation allows you to tell the difference.

■ **Note** Sums, averages, maximums, and minimums can also be computed by using F# 3.0 *query expressions*, discussed in Chapter 13. For example, you can compute an average by using an expression such as `query { for x in data do averageBy p.X }`. The advantage of this approach is that, for some external data sources such as databases, the queries and aggregation can be executed on the remote server. As we shall see in Chapter 13, this depends on how *data* has been defined. While queries can be used over sequences and other in-memory data, for most in-memory processing, you should just use operations such as `Seq.averageBy` to process the data.

## Counting and Categorizing

A common statistical operation is categorizing elements according to some *key* (grouping, as discussed in Chapter 9) and counting the number of elements in each group. This corresponds to building a histogram for the data based on a selection function.

The simplest way to generate a histogram for in-memory data is to use `Seq.countBy`, which returns a sequence of key/count pairs. For example, consider the `random3Dpoints` you generated in the previous section. These can be categorized into 10 quantiles depending on how far they are from the origin. The maximum distance a point can be away from the origin is  $\sqrt{3}$ , so we multiply by 10, divide by  $\sqrt{3}$ , and round down to the nearest integer to compute the bucket a point belongs to:

```
let histogram =
    random3Dpoints
    |> Seq.countBy (fun p -> int (norm p * 10.0 / sqrt 3.0) )
    |> Seq.sortBy fst
    |> Seq.toList
```

The results reveal a concentration of points at distance  $0.6 * \sqrt{3} = 1.03$ .

```
// Random numbers, results may differ!
val closest : (int * int) list =
    [(0, 1); (1, 15); (2, 52); (3, 97); (4, 173); (5, 233); (6, 256); (7, 116);
     (8, 52); (9, 5)]
```

Note that you usually have to sort the counted results by the key and convert the overall results to a concrete data structure, such as a list, array, map, or dictionary.

■ **Note** The Math.NET library includes the type `Statistics.Histogram` for incrementally computing histograms from numerical input sets. You use this type later in this chapter.

## Writing Fresh Numeric Code

If you are writing a lot of numeric code, you will almost certainly want to use one of the standard math and statistical packages that can be used with F# programming, such as Math.NET, described later in this chapter. It is often necessary, however, to define new statistical computations in F# to extend the basic set of operations that are available for routine use.

As an example of this, consider defining the *variance* and *standard deviation* of a sequence of numbers. These are simple computations based on taking the average of a sequence and then the average of the sum-of-squares of variations from the average.

First, the simplest form of the operation simply computes the variance over an input array of floating-point numbers:

```
/// Compute the variance of an array of inputs
let variance (values : float[]) =
    let sqr x = x * x
    let avg = values |> Array.average
    let sigma2 = values |> Array.averageBy (fun x -> sqr (x - avg))
    sigma2

let standardDeviation values =
    sqrt (variance values)
```

These operations have types:

---

```
val variance : values:float [] -> float
val standardDeviation : values:float [] -> float
```

---

You can apply the functions to sequences of data. For example:

```
let sampleTimes = [|for x in 0 .. 1000 -> 50.0 + 10.0 * rand()|]

let exampleDeviation = standardDeviation sampleTimes
let exampleVariance = variance sampleTimes
```

Giving results:

---

```
val exampleDeviation : float = 2.865331753
val exampleVariance : float = 8.210126054
```

---

In some circumstances, it may make sense to define projection “By” versions of these operations, and further, it may make sense to place the operations in a utility module called “Seq”, “Array” or “List”, depending on the kind of input data accepted by the routine:

```
module Seq =
    /// Compute the variance of the given statistic from from the input data
    let varianceBy (f : 'T -> float) values =
        let sqr x = x * x
        let xs = values |> Seq.map f |> Seq.toArray
        let avg = xs |> Array.average
        let res = xs |> Array.averageBy (fun x -> sqr (x - avg))
        res
```

```

/// Compute the standard deviation of the given statistic drawn from the input data
let standardDeviationBy f values =
    sqrt (varianceBy f values)

```

---

■ **Note** The Math.NET library includes the functions `Statistics.StandardDeviation`, `Statistics.Variance`, `Statistics.Mean`, `Statistics.Maximum`, `Statistics.Minimum`, and `Statistics.DescriptiveStatistics` for computing basic statistics from sequences of floating-point numbers.

---

## Making Numeric Code Generic

It is often sufficient to define statistical functions over base types, such as floating-point numbers. If necessary, this code can be made either *unitized* or *generic*. You have already seen generic numeric algorithms in Chapter 5. You can make the code for variance and `standardDeviation` generic, because the underlying operations `Array.average` and `Array.averageBy` are themselves generic. For example:

```

let inline variance values =
    let sqr x = x * x
    let avg = values |> Array.average
    let sigma2 = values |> Array.averageBy (fun x -> sqr (x - avg))
    sigma2

let inline standardDeviation values =
    sqrt (variance values)

```

This code can now be used with any numeric types. The downside is that a complex relationship is asserted between the input and output types:

---

```

val inline variance :
    values: ^a [] -> ^c
    when ^a : (static member ( + ) : ^a * ^a -> ^a) and
         ^a : (static member DivideByInt : ^a * int -> ^a) and
         ^a : (static member get_Zero : -> ^a) and
         ^a : (static member ( - ) : ^a * ^a -> ^b) and
         ^b : (static member ( * ) : ^b * ^b -> ^c) and
         ^c : (static member ( + ) : ^c * ^c -> ^c) and
         ^c : (static member DivideByInt : ^c * int -> ^c) and
         ^c : (static member get_Zero : -> ^c)

val inline standardDeviation :
    values: ^a [] -> ^d
    when ^a : (static member ( + ) : ^a * ^a -> ^a) and
         ^a : (static member DivideByInt : ^a * int -> ^a) and
         ^a : (static member get_Zero : -> ^a) and
         ^a : (static member ( - ) : ^a * ^a -> ^b) and
         ^b : (static member ( * ) : ^b * ^b -> ^c) and
         ^c : (static member ( + ) : ^c * ^c -> ^c) and
         ^c : (static member DivideByInt : ^c * int -> ^c) and
         ^c : (static member get_Zero : -> ^c) and
         ^c : (static member Sqrt : ^c -> ^d)

```

---

This cost can sometimes be worth it, as the operation is very general—it can be used on decimals, floating-point numbers, and unitized versions of these. Further, the code produced is also usually as efficient as can be without writing a highly case-specific optimized routine.

## Example: KMeans

As an example, in Listing 10-1, we use one simple machine-learning algorithm, called *KMeans Clustering*. This algorithm accepts a set of inputs, each with a vector of numbers representing *features*. For example, each input may represent an observed object, such as a flower or animal in a biology field experiment, and the features may represent a set of observed measurements of that object.

The algorithm proceeds by clustering the data around a fixed number of centroids in the feature space. Each object is assigned to the “nearest” centroid according to a distance function. Once the groups are determined, new centers are then computed, and the process is repeated.

In this implementation of the algorithm, we keep a reference to the original data, of some type *T*, and assume a function is given that extracts the actual feature vectors from the parameters.

### Listing 10-1. KMeans Clustering Algorithm

```

type Input<T> = {Data : 'T; Features : float[]}
type Centroid = float[]

module Array =
    // Like Seq.groupBy, but returns arrays
    let classifyBy f (xs : _[]) =
        xs |> Seq.groupBy f |> Seq.map (fun (k, v) -> (k, Seq.toArray v)) |> Seq.toArray

module Seq =
    // Return x, f(x), f(f(x)), f(f(f(x))), ...
    let iterate f x = x |> Seq.unfold (fun x -> Some (x, f x))

    // Compute the norm distance between an input and a centroid
    let distance (xs : Input<_>) (ys : Centroid) =
        (xs.Features,ys)
        |> Array.map2 (fun x y -> (x - y) * (x - y))
        |> Array.sum

    // Find the average of set of inputs. First compute xs1 + ... + xsN, pointwise,
    // then divide each element of the sum by the number of inputs.
    let computeCentroidOfGroup (_, group : Input<_>[]) =
        let e0 = group.[0].Features
        [|for i in 0 .. e0.Length - 1 -> group |> Array.averageBy (fun e -> e.Features.[i])|]

    // Group all the inputs by the nearest centroid
    let classifyIntoGroups inputs centroids =
        inputs |> Array.classifyBy (fun v -> centroids |> Array.minBy (distance v))

    // Repeatedly classify the inputs, starting with the initial centroids
    let rec computeCentroids inputs centroids = seq {
        let classification = classifyIntoGroups inputs centroids
        yield classification
    }

```

```
let newCentroids = Array.map computeCentroidOfGroup classification
yield! computeCentroids inputs newCentroids}
```

```
/// Extract the features and repeatedly classify the inputs, starting with the
/// initial centroids
```

```
let kmeans inputs featureExtractor initialCentroids =
    let inputs =
        inputs
        |> Seq.map (fun i -> {Data = i; Features = featureExtractor i})
        |> Seq.toArray
    let initialCentroids = initialCentroids |> Seq.toArray
    computeCentroids inputs initialCentroids
```

We now generate a synthetic input data set that features four clusters of data:

```
open Microsoft.FSharp.Data.UnitSystems.SI.UnitSymbols

type Observation = {Time : float<s>; Location : float<m>}

let rnd = System.Random()
let rand() = rnd.NextDouble()
let randZ() = rnd.NextDouble() - 0.5

/// Create a point near the given point
let near p = {Time= p.Time + randZ() * 20.0<s>;
              Location = p.Location + randZ() * 5.0<m>}
```

```
let data =
    [for i in 1 .. 1000 -> near {Time= 100.0<s>; Location = 60.0<m>}
    for i in 1 .. 1000 -> near {Time= 120.0<s>; Location = 80.0<m>}
    for i in 1 .. 1000 -> near {Time= 180.0<s>; Location = 30.0<m>}
    for i in 1 .. 1000 -> near {Time= 70.0<s>; Location = 40.0<m>}]
```

The algorithm is run by extracting two features from the data into a normalized (0,1) range and choosing 10 initial centroids at random in this two-dimensional feature space.

We discard the classifications of the points to the centroids and simply report the centroids that have been found, renormalized into the original input space:

```
let maxTime = data |> Seq.maxBy (fun p -> p.Time) |> fun p -> p.Time
let maxLoc = data |> Seq.maxBy (fun p -> p.Location) |> fun p -> p.Location

let initialCentroids = [for i in 0 .. 9 -> [|rand(); rand()|]]
let featureExtractor (p : Observation) = [|p.Time / maxTime; p.Location / maxLoc|]
```

```
kmeans data featureExtractor initialCentroids
```

This gives an infinite sequence of centroid/classification groups representing repeated iterations of the algorithm. We discard the classifications and simply report the centroids that have been found, taking only the 100th iteration of the algorithm, and renormalize the centroids into the original input space:

```
kmeans data featureExtractor initialCentroids
|> Seq.map (Array.map (fun (c, _) -> c.[0] * maxTime, c.[1] * maxLoc))
|> Seq.nth 100
```

This gives the resulting centroids. For example, on one sample execution, the discovered centroids for the 100th iteration are:

---

```
> val it : (float<s> * float<m>) [] =
  [| (95.21297664, 59.92134092); (105.128182, 60.03017317);
    (120.0522592, 79.99954457); (179.7447501, 29.96446713);
    (65.97080136, 38.75120135); (75.63604991, 40.05351476);
    (64.8228706, 41.26265782) |]
```

---

The algorithm has determined seven centroids—those that no classify no points are discarded—and each of these correspond to one of the four original centroids—(100,60), (120,80), (180,30), (70,40)—used in the random generation of the data. (Several discovered centroids correspond to one original centroid; thus, the data are “over-fitted.” The over-fitting of the centroid model to the data is characteristic of naïve clustering algorithms. The use of more advanced statistical methods can avoid this.)

## Statistics, Linear Algebra and Distributions with Math.NET

In this chapter so far, you have seen how to use F# language and library constructs to implement a variety of numerical programming tasks “from scratch.” This is commonly done when using F# for writing simulators or doing basic data scripting, charting, and reporting.

For even moderately advanced math and numeric programming, however, you will want to make use of an existing F# or .NET math library. Several high-quality .NET libraries are available, and more are appearing all the time. Also, math and statistics libraries tend to have different characteristics:

- Some libraries use C/C++ code “under the hood.” For example, many managed .NET libraries use the Intel MKL library or an equivalent.
- Some libraries also have an “all managed” mode, meaning that most or all of the functionality in the library is authored in C# and F#. This means, for example, that math libraries can be highly portable and used across a number of situations in which .NET code is accepted.
- Some libraries implement optimizations such as “GPU” execution, allowing some or all of the routines to execute on a graphics processor.
- The libraries differ by license and availability. Some are open source, and some are commercial.
- Some libraries are designed for use from C# or F# but also have an F#-specific wrapper.

A detailed overview of math library choices for F# can also be found on the Microsoft MSDN pages at <http://msdn.microsoft.com/en-us/library/hh304368.aspx>. People often ask us which libraries we recommend. Table 10-6 shows some of the frameworks and libraries available at the time of writing that may interest you.

*Table 10-6. Some Math Frameworks and Libraries Not Covered in This Chapter*

Library Name	Description	URL
Alglib	ALGLIB is a cross-platform numerical-analysis and data-processing library.	<a href="http://www.alglib.net">www.alglib.net</a>
Extreme Optimization	A commercial math, vector, statistics, and matrix library for .NET.	<a href="http://www.extremeoptimization.com">www.extremeoptimization.com</a>
FCore	A commercial F#-specific math and statistics library, particularly suitable for quantitative development.	<a href="http://www.statfactory.co.uk">www.statfactory.co.uk</a>
Math.NET	The standard open-source math library for the .NET Framework. Includes special functions, linear algebra, probability models, statistics, random numbers, interpolation, and integral transforms (FFT).	<a href="http://www.mathdotnet.com">www.mathdotnet.com</a>
NMath	An object-oriented .NET math library that supports linear algebra and function optimization. NMath Stats is a .NET statistics library that can be used for data manipulation and statistical computation, as well as for biostatistics.	<a href="http://www.centerspace.net">www.centerspace.net</a>

## Basic Statistical Functions in Math.NET Numerics

In the rest of this book, we use the open-source library Math.NET Numerics. The preferred open-source math library for use with F# is called Math.NET Numerics, which is part of a larger project called Math.NET, an umbrella project for open-source math libraries on the .NET and Mono Frameworks. Math.NET Numerics includes:

- Types representing dense as well sparse vectors and matrices
- A library containing a full set of standard linear-algebra routines
- A range of random-number generators with different strengths
- Additional features that include support for certain numerical integration and statistical functions.

Math.NET Numerics is available for use as a pure-managed library, but it also includes wrappers for highly optimized native math libraries, such as Intel MKL and AMD ACML. This library is available under a broad open-source license, and it is available as a NuGET package. To install the library, either add it as a NuGET package to an existing project or install it directly from [www.mathdotnet.com](http://www.mathdotnet.com).

From an F# script in the root folder of a project with version 2.1.2 of MathNet.Numerics.FSharp installed as a NuGET package, the references can be added with relative paths.

```
#r @"..\packages\MathNet.Numerics.2.1.2\lib\Net40\MathNet.Numerics.dll"
#r @"..\packages\MathNet.Numerics.FSharp.2.1.2\lib\Net40\MathNet.Numerics.FSharp.dll"
#r @"..\packages\zlib.net.1.0.4.0\lib\zlib.net.dll"
```

Some basic statistical functions in Math.NET are shown in Table 10-7. We can use the functions in the expected way:

```
open MathNet.Numerics.Statistics

let data = [for i in 0.0 .. 0.01 .. 10.0 -> sin i]

let exampleVariance = data |> Statistics.Variance
let exampleMean = data |> Statistics.Mean
let exampleMin = data |> Statistics.Minimum
let exampleMax = data |> Statistics.Maximum
```

Giving:

---

```
val exampleVariance : float = 0.443637494
val exampleMean : float = 0.1834501596
val exampleMin : float = -0.9999971464
val exampleMax : float = 0.9999996829
```

---

**Table 10-7.** Some Statistical Functions in Math.NET, in Namespace `MathNet.Numerics.Statistics`

Notation	Description	URL
•	Standard Deviation	<code>Statistics.StandardDeviation</code>
• <sup>2</sup>	Variance	<code>Statistics.Variance</code>
μ	Mean	<code>Statistics.Mean</code>
max	Maximum	<code>Statistics.Maximum</code>
min	Minimum	<code>Statistics.Minimum</code>
	Computes an object giving a range of descriptive statistics for a set of numbers	<code>Statistics.DescriptiveStatistics</code>
$\binom{n}{k}$	Binomial function, number of ways of choosing k elements from n choices, “n choose k”	<code>Combinatorics.Combinations</code> <code>SpecialFunctions.Binomial</code>
$\binom{n}{k_1, k_2, \dots, k_r} = \frac{n!}{k_1! k_2! \dots k_r!}$	Multinomial function	<code>SpecialFunctions.Multinomial</code>
<code>erf(x)</code>	Error function	<code>SpecialFunctions.Erf</code>
<code>erfc(x)</code>	Complementary Error function	<code>SpecialFunctions.Erfc</code>
•(x)	Gamma function	<code>SpecialFunctions.Gamma</code>
<code>B(x,y)</code>	Beta function	<code>SpecialFunctions.Beta</code>
<code>n!</code>	Factorial function	<code>SpecialFunctions.Factorial</code>

## Using Histograms and Distributions from Math.NET Numerics

The Math.NET Numerics library includes implementations of all the most important statistical distributions in the namespace `MathNet.Numerics.Distributions`. For example, consider a normal (bell-curve) distribution centered on 100.0 with standard deviation 10.0.

```
open MathNet.Numerics.Distributions
open System.Collections.Generic

let exampleBellCurve = Normal(100.0, 10.0)
```



You can now draw random samples from this distribution as:

---

```
> exampleBellCurve.Samples();

val it : IEnumerable<float> =
  seq [102.4361311; 88.10527203; 100.1478871; 88.2344663; ...]
```

---

Math.NET Numerics also includes a type `MathNet.Numerics.Distributions.Histogram` for categorizing numeric data into a histogram. For example, we can define a function that categorizes data into a given number of buckets and generates a label for each bucket as:

```
let histogram n data =
  let h = Histogram(data, n)
  [|for i in 0 .. h.BucketCount - 1 ->
    (sprintf "%.0f-%.0f" h.[i].LowerBound h.[i].UpperBound, h.[i].Count)|]
```

Using this function, we can now chart the sample data drawn from the normal distribution as:

```
exampleBellCurve.Samples()
|> Seq.truncate 1000
|> histogram 10
|> Chart.Column
```

Giving:

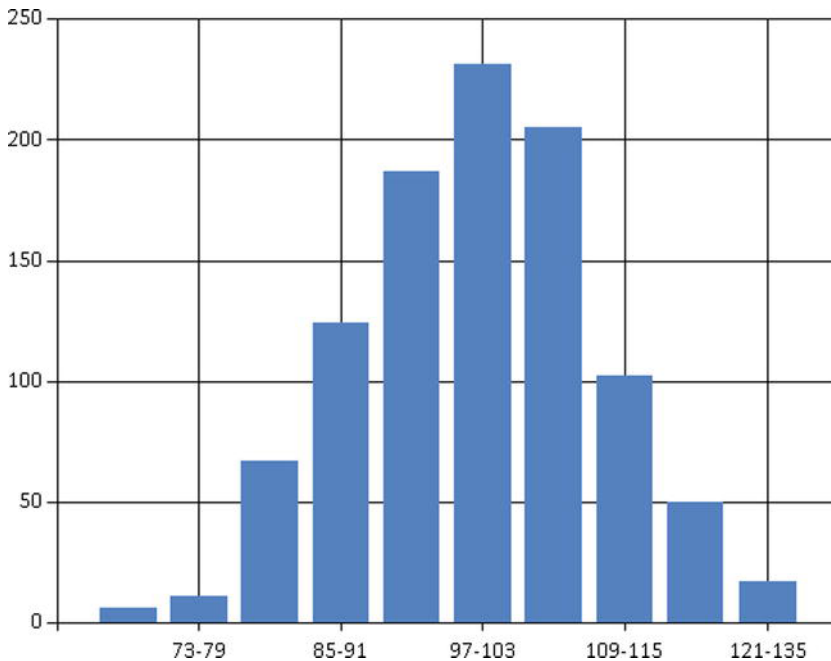

The Math.NET library supports many more-sophisticated distribution types, including multivariate Gaussian distributions (`MatrixNormal`), coin flips (`Bernoulli`), decaying-exponential distributions (`Exponential`), and distributions that can be used to simulate the time delays between occurrences of events (`Poisson`).

## Using Matrices and Vectors from Math.NET

The Math.NET Numerics library includes extensive support for matrices, vectors, and linear algebra. For example, you can create and add two vectors:

```
open MathNet.Numerics.FSharp
open MathNet.Numerics.LinearAlgebra.Generic

let vector1 = vector [1.0; 2.4; 3.0]
let vector2 = vector [7.0; 2.1; 5.4]
```

vector1 + vector2

giving:

---

```
val it : Vector<float> = seq [8.0; 4.5; 8.4]
```

---

Likewise, you can define and multiply two matrices:

```
let matrix1 = matrix [[1.0; 2.0]; [1.0; 3.0]];;
let matrix2 = matrix [[1.0; -2.0]; [0.5; 3.0]];;
let matrix12 = matrix1 * matrix2;;
```

Giving:

---

```
val matrix1 : Matrix<float> = 1,2
1,3
val matrix2 : Matrix<float> = 1,-2
0.5,3
val matrix12 : Matrix<float> = 2,4
2.5,7
```

---

The default formatting for vectors and matrices is not particularly good. Better formatting can be achieved by adding a print-transformer to first convert to one- or two-dimensional arrays, which offers better formatting in F# Interactive:

```
open MathNet.Numerics.LinearAlgebra.Double

fsi.AddPrintTransformer (fun (x : DenseVector) ->
    box [|for i in 0 .. x.Count - 1 -> x.[i]|])

fsi.AddPrintTransformer (fun (x : DenseMatrix) ->
    box (array2D [for i in 0 .. x.RowCount - 1 ->
        [for j in 0 .. x.ColumnCount - 1 -> x.[i, j]]]))
```

The results above then become:

---

```
val vector1 : Vector<float> = [|1.0; 2.4; 3.0|]
val vector2 : Vector<float> = [|7.0; 2.1; 5.4|]
val it : Vector<float> = seq [8.0; 4.5; 8.4]
```

---

and:

---

```
val matrix1 : Matrix<float> = [[1.0; 2.0]
                             [1.0; 3.0]]
val matrix2 : Matrix<float> = [[1.0; -2.0]
                             [0.5; 3.0]]
val matrix12 : Matrix<float> = [[2.0; 4.0]
                              [2.5; 7.0]]
```

---

## Matrix Inverses, Decompositions and Eigenvalues

The linear-algebra support in the Math.NET Numerics library is extensive and can be configured to use highly optimized native linear-algebra packages under-the-hood. The defaults are to use fully managed linear algebra. For example, to compute the inverse of a matrix, simply call the `.Inverse()` method on the matrix.

First, define a large 100x100 matrix with random numbers and compute its inverse:

```
let largeMatrix = matrix [for i in 1 .. 100 -> [for j in 1 .. 100 -> rand()]]

let inverse = largeMatrix.Inverse()
```

Next, multiply the two to check that the inverse is correct:

```
let check = largeMatrix * largeMatrix.Inverse()
```

Giving:

---

```
val check : Matrix<float> =
  [[1.0; 2.775557562e-16; 4.371503159e-15; 1.887379142e-15; 1.887379142e-15;
    -1.054711873e-15; -2.664535259e-15; 6.689093723e-15; 4.440892099e-16;
    -5.551115123e-16; -2.664535259e-15; -5.551115123e-16; 2.664535259e-15;
    -2.220446049e-15; 1.110223025e-16; -1.776356839e-15; -2.886579864e-15;
    ...
```

---

As expected, this is numerically very close to the identity matrix. Likewise, common decompositions of matrices can be computed using the `Svd()`, `Evd()`, `LU()`, and `QR()` methods on the matrix itself. For example, to compute the eigenvalues and eigenvectors of a matrix:

```
// Open this namespace so we can use the Evd extension method.
open MathNet.Numerics.LinearAlgebra.Double
open MathNet.Numerics.LinearAlgebra.Generic

let evd = largeMatrix.Evd()
let eigenValues = evd.EigenValues()
```

Giving:

---

```
val evd : Factorization.Evd
val eigenValues : Vector<Numerics.Complex>

> eigenValues;;
```

```
val it : Vector<Numerics.Complex> =
  seq
    [(49.9915503772098, 0);
     (-0.406120558380603, 2.92962073514449);
     ...]
```

---

Adding a printer for complex numbers:

```
fsi.AddPrinter (fun (c : System.Numerics.Complex) -> sprintf "%fr + %fi" c.Real c.Imaginary)
```

Gives:

```
val eigenValues : Vector<Numerics.Complex> =
  seq
    [49.991550r + 0.000000i; -0.406121r + 2.929621i; -0.406121r + -2.929621i;
     3.095556r + 0.000000i; ...]
```

---

## Units of Measure

F# includes a beautiful feature in its type system called *units of measure*. This feature lets you annotate numeric types with annotations such as `kg`, `m`, and `sec` that indicate the kind of number the quantity represents—that is, its unit of measure. You can also use the feature to annotate other, user-defined types that are ultimately based on numeric quantities. This feature is best explained using code for physical simulations and is rooted in scalable quantities. It also has a wide range of surprising applications outside physical simulation, including annotating code with units for integer quantities such as pixels, currencies, or click-counts.

The F# 3.0 library comes with predefined unit definitions matching the *Système International* (SI) standard in the namespaces `Microsoft.FSharp.Data.UnitSystems.SI.UnitNames` (for base unit names such as kilogram and derived units such as hertz) and namespaces `Microsoft.FSharp.Data.UnitSystems.SI.UnitSymbols` (for standard abbreviations of these names, such as `kg` and `hz`, respectively). To define a new kind of measure annotation, use a type definition with a `Measure` attribute:

```
[<Measure>]
type click
```

```
[<Measure>]
type pixel
```

```
[<Measure>]
type money
```

Once a set of measures is defined or chosen from the library, the basic numeric types and literals can include these qualifications. For example, consider the computation “we are receiving 200 clicks every second, and the Web site has been running 3.5 seconds.” This computation can be performed as:

```
open Microsoft.FSharp.Data.UnitSystems.SI.UnitNames
open Microsoft.FSharp.Data.UnitSystems.SI.UnitSymbols
```

```
let rateOfClicks = 200.0<click/s>
let durationOfExecution = 3.5<s>
```

A calculation involving these quantities is:

```
let numberOfClicks = rateOfClicks * durationOfExecution
```

The inferred type of `numberOfClicks` is `float<click>`.

```
val numberOfClicks: float<click> = 700.0
```

If a mismatched unit type is used in such a calculation, a type error is reported.

## Adding Units to a Numeric Algorithms

Code that uses units of measure may also be generic over the units involved. This is particularly important for generic algorithms. To demonstrate this, consider three simple algorithms for integrating a function, as learned in elementary calculus. We will take the first three numerical-integration techniques for integrating a function  $f(x)$  of one variable over the range from  $a$  to  $b$ , taken from [http://en.wikipedia.org/wiki/Numerical\\_integration](http://en.wikipedia.org/wiki/Numerical_integration). These are

- integrating by evaluating  $f$  at a midpoint

$$\int_a^b f(x) dx \approx (b - a) f\left(\frac{a + b}{2}\right).$$

- integrating by evaluating  $f$  at the endpoints

$$\int_a^b f(x) dx \approx (b - a) \frac{f(a) + f(b)}{2}.$$

- integrating by evaluating  $f$  at a mesh of  $n$  sub-intervals evenly spaced between  $a$  and  $b$

$$\int_a^b f(x) dx \approx \frac{b - a}{n} \left( \frac{f(a) + f(b)}{2} + \sum_{k=1}^{n-1} f\left(a + k \frac{b - a}{n}\right) \right)$$

Translating these into code, the nonunitized implementations are:

```
let integrateByMidpointRule f (a, b) = (b - a) * f ((a + b) / 2.0)
```

```
let integrateByTrapezoidalRule f (a, b) = (b - a) * ((f a + f b) / 2.0)
```

```
let integrateByIterativeRule f (a, b) n =
  (b - a) / float n *
  ((f a + f b) / 2.0 +
   List.sum [for k in 1 .. n - 1 -> f (a + float k * (b - a) / float n)])
```

Here are the unitized implementations. Note that you author the unitized numbers by introducing type annotations:

```
let integrateByMidpointRule (f : float<'u> -> float<'v>) (a : float<'u>, b : float<'u>) =
  (b - a) * f ( (a+b) / 2.0)
```

```
let integrateByTrapezoidalRule (f : float<'u> -> float<'v>) (a : float<'u>, b : float<'u>) =
  (b - a) * ((f a + f b) / 2.0)
```

```
let integrateByIterativeRule (f : float<'u> -> float<'v>) (a : float<'u>, b : float<'u>) n =
    (b - a) / float n *
    ((f a + f b) / 2.0 +
     List.sum [for k in 1 .. n - 1 -> f (a + float k * (b - a) / float n)])
```

In all three cases, the inferred, generic unitized type for the functions gives a return type of `float<'u 'v>`:

---

```
val integrateByMidpointRule :
  f:(float<'u> -> float<'v>) -> a:float<'u> * b:float<'u> -> float<'u 'v>
val integrateByTrapezoidalRule :
  f:(float<'u> -> float<'v>) -> a:float<'u> * b:float<'u> -> float<'u 'v>
val integrateByIterativeRule :
  f:(float<'u> -> float<'v>) ->
  a:float<'u> * b:float<'u> -> n:int -> float<'u 'v>
```

---

For example, if the  $x$  dimension is “time”,—for example, `float<s>`—and the  $y$  dimension is “velocity”—for example, `float<m/s>`—the result type is `float<s m / s>`, which simplifies to `float<m>`—for example, a distance. This is as expected: integrating a velocity over a period of time gives the distance travelled.

When we run these implementations of integration using a linear function as input, they all give the same answer. For example, consider a velocity function for a ball thrown upward at an initial velocity of `100.0<m/s>` and falling back to earth at `9.81<m/s>`. Using the numeric-integration techniques, we can evaluate the distance the ball is above the earth at time 10 seconds as:

```
let velocityFunction (t : float<s>) = 100.0<m/s> + t * -9.81<m/s^2>

let distance1 = integrateByMidpointRule velocityFunction (0.0<s>, 10.0<s>)
let distance2 = integrateByTrapezoidalRule velocityFunction (0.0<s>, 10.0<s>)
let distance3 = integrateByIterativeRule velocityFunction (0.0<s>, 10.0<s>) 10
```

As expected, the results of these approximate integration techniques are precise for a linear function, and in all three cases, the distance computed is 509.5 meters:

---

```
val distance1 : float<m> = 509.5
val distance2 : float<m> = 509.5
val distance3 : float<m> = 509.5
```

---

As our second example, consider adding units to the variance function you defined earlier in this chapter. In this case, we also change the input to be a sequence, to make the operation more general still:

```
let variance (values : seq<float<_>>) =
    let sqr x = x * x
    let xs = values |> Seq.toArray
    let avg = xs |> Array.average
    let variance = xs |> Array.averageBy (fun x -> sqr (x - avg))
    variance

let standardDeviation values =
    sqrt (variance values)
```

The types of the operations are now unitized:

---

```
val variance : values:seq<float<'u>> -> float<'u ^ 2>
val standardDeviation : values:seq<float<'u>> -> float<'u>
```

---

You can now apply the functions to unitized sequences of data. For example:

```
let sampleTimes = [for x in 0 .. 1000 -> 50.0<s> + 10.0<s> * rand()]

let exampleDeviation = standardDeviation sampleTimes
let exampleVariance = variance sampleTimes
```

Giving:

---

```
val exampleDeviation : float<s> = 2.865331753
val exampleVariance : float<s ^ 2> = 8.210126054
```

---

## Adding Units to a Type Definition

When you define a new type, you may include measure parameters as part of the definition of the type. These parameters must be marked with the Measure attribute. For example:

```
type Vector2D<[<Measure>] 'u> = {DX : float<'u>; DY : float<'u>}
```

You can use units of measure in conjunction with object-oriented programming, discussed in Chapter 6. For example, here is a vector-type generic over units of measure:

```
/// Two-dimensional vectors
type Vector2D<[<Measure>] 'u>(dx : float<'u>, dy : float<'u>) =

    /// Get the X component of the vector
    member v.DX = dx

    /// Get the Y component of the vector
    member v.DY = dy

    /// Get the length of the vector
    member v.Length = sqrt(dx * dx + dy * dy)

    /// Get a vector scaled by the given factor
    member v.Scale k = Vector2D(k * dx, k * dy)

    /// Return a vector shifted by the given delta in the X coordinate
    member v.ShiftX x = Vector2D(dx + x, dy)

    /// Return a vector shifted by the given delta in the Y coordinate
    member v.ShiftY y = Vector2D(dx, dy + y)

    /// Get the zero vector
    static member Zero = Vector2D<'u>(0.0<_>, 0.0<_>)
```

```

/// Return a constant vector along the X axis
static member ConstX dx = Vector2D<'u>(dx, 0.0<_>)

/// Return a constant vector along the Y axis
static member ConstY dy = Vector2D<'u>(0.0<_>, dy)

/// Return the sum of two vectors
static member (+) (v1 : Vector2D<'u>, v2 : Vector2D<'u>) =
    Vector2D(v1.DX + v2.DX, v1.DY + v2.DY)

/// Return the difference of two vectors
static member (-) (v1 : Vector2D<'u>, v2 : Vector2D<'u>) =
    Vector2D(v1.DX - v2.DX, v1.DY - v2.DY)

/// Return the pointwise-product of two vectors
static member (.*) (v1 : Vector2D<'u>, v2 : Vector2D<'u>) =
    Vector2D(v1.DX * v2.DX, v1.DY * v2.DY)

```

Note that some measure annotations are needed on zero values in this sample. In addition, a vector type such as this should normally implement the `IComparable` interface and the `Equals` and `GetHashCode` methods, as described in Chapter 8.

## Applying and Removing Units

When you have a unitized value, you can remove the units by simply applying the `float` function. When you have a nonunitized value, you can apply units to it by using `LanguagePrimitives.FloatWithMeasure`. For example:

```

let three = float 3.0<kg>
let sixKg = LanguagePrimitives.FloatWithMeasure<kg> (three + three)
    Giving:
val three : float = 3.0
val sixKg : float<kg> = 6.0

```

## Some Limitations of Units of Measure

Units of measure can help tame the sea of floating-point numbers that tends to characterize modern numerical programming. It is important, however, to be aware of limitations of this feature, to avoid its over-zealous application to the detriment of productivity, code-stability, and readability. In particular:

- Units of measure work best for algorithms that deal with summing, multiplying, dividing, and taking integral roots of inputs, such as square roots. Units of measure do not work well for algorithms or computations that deal with other functions, such as exponentials. Algorithms that use these functions can still often be “coarsely” unitized, first by removing units from the inputs and then by reapplying them to the outputs.
- Units of measure must be applied to a particular type, such as `float<_>`, `decimal<_>`, or a user-defined type, such as `Vector2D<_>` above. In particular, you can’t easily be generic over both this type *and* the unit of measure, except by writing an inlined generic algorithm, as explained in Chapter 5.



- Units of measure are an F#-only feature, and they are “erased” at runtime. This means that the unit information isn’t available to “reflective” metaprogramming. Unit information *can* be provided by F# type providers, something we will look at in Chapter 17.

---

■ **Note** F# units of measure are covered only briefly in this book. For more information, see the MSDN documentation or Andrew Kennedy’s four-part introduction to the topic: search for “Andrew Kennedy Units of Measure Part One” or visit <http://blogs.msdn.com/andrewkennedy>.

---



---

### EXERCISE: UNITIZING KMEANS

---

The KMeans algorithm uses distances between feature vectors based on sums of squares. This means that the feature vectors should, ideally, be “normalized” to prevent one dimension dominating another.

This indicates that units of measure can be used with the algorithm, in the sense that the algorithm should be generic w.r.t. to the “dimension” of the normalized numbers used in the feature space. As an exercise, try to apply units of measure to the code above. Start by making the type definitions unitized in this way:

```
type Input<'T, [<Measure>] 'u> =
    { Data : 'T
      Features: float<'u>[] }
```

```
type Centroid[<Measure>] 'u = float<'u>[]
```

You then simply need to adjust the code in a couple of places, and type inference will look after the rest. The adjustments needed are:

```
let distance (xs : Input<_, _>) (ys : Centroid<_>) = ...
```

```
let computeCentroidOfGroup (_, group : Input<_>[[]]) = ...
```

---

## Summary

In this chapter, you’ve seen how to use F# to perform a range of numeric programming tasks, including the use of the powerful open-source Math.NET library. In the next chapter, we turn to an increasingly important part of programming— building parallel, reactive, and event-driven systems.

## CHAPTER 11



# Reactive, Asynchronous, and Parallel Programming

So far in this book, you've seen functions and objects that process their inputs immediately using a single thread of execution in which the code runs to completion and produces useful results or state changes. In this chapter, you turn your attention to *concurrent*, *parallel*, *asynchronous*, and *reactive* programs. These represent substantially different approaches to programming from those you've seen so far. Some reasons for turning to these techniques are:

- To achieve better responsiveness in a graphical user interface (GUI)
- To report progress results during a long-running computation and to support cancellation of these computations
- To achieve greater throughput in a reactive application or service
- To achieve faster processing rates on a multiprocessor machine or cluster
- To take advantage of the I/O parallelism available in modern disk drives or network connections
- To sustain processing while network and disk I/O operations are in process

This chapter covers some techniques that can help achieve these outcomes:

- Using threads and the `BackgroundWorker` class for background computations
- Using events and messages to report results back to a GUI
- Using F# asynchronous workflows and the “thread pool” to handle network requests and other asynchronous I/O operations
- Using F# pattern matching to process message queues
- Using low-level shared-memory primitives to implement new concurrency techniques and control access to mutable data structures

In Chapter 2, you saw a very simple sample of the most common type of reactive programs: GUI programs that respond to events raised on the GUI thread. The inner loop of such an application (contained in the Windows Forms library) spends most of its time blocked and waiting for the underlying operating system to notify it of a relevant event, such as a click from the user or a timer event from the

operating system. This notification is received as an event in a message queue. Many GUI programs have only a single thread of execution, so all computation happens on the GUI thread. This can lead to problems, such as nonresponsive user interfaces. This is one of many reasons it's important to master some techniques of concurrent and asynchronous programming.

## Introducing Some Terminology

Let's begin by looking more closely at some terminology:

- *Processes* are, in the context of this chapter, standard operating system (OS) processes. Each instance of the .NET Common Language Runtime (CLR) runs in its own process, and multiple instances of the .NET CLR are often running on the same machine.
- *Threads* are, in the context of this chapter, standard .NET threads. On most implementations of .NET, these correspond to operating system threads. Each .NET process has many threads running within the one process.
- *Concurrent programs* are ones with multiple threads of execution, each typically executing different code, or at different execution points within the same code. Simultaneous execution may be simulated by scheduling and descheduling the threads, which is done by the OS. For example, most OS services and GUI applications are concurrent.
- *Parallel programs* are one or more processes or threads executing simultaneously. For example, many modern microprocessors have two or more physical CPUs capable of executing processes and threads in parallel. Parallel programs can also be *data parallel*. For example, a massively parallel device, such as a graphics processor unit (GPU), can process arrays and images in parallel. Parallel programs can also be a cluster of computers on a network, communicating via message passing. Historically, some parallel scientific programs have even used e-mail for communication.
- *Asynchronous programs* perform requests that don't complete immediately but that are fulfilled at a later time and where the program issuing the request has to do meaningful work in the meantime. For example, most network I/O is inherently asynchronous. A web crawler is also a highly asynchronous program, managing hundreds or thousands of simultaneous network requests.
- *Reactive programs* are ones whose normal mode of operation is to be in a state of waiting for some kind of input, such as waiting for user input or for input from a message queue via a network socket. For example, GUI applications and web servers are reactive programs.

Parallel, asynchronous, concurrent, and reactive programs bring many challenges. For example, these programs are nearly always *nondeterministic*. This makes debugging more challenging, because it's difficult to step through a program; even pausing a running program with outstanding asynchronous requests may cause timeouts. Most dramatically, incorrect concurrent programs may *deadlock*, which means that all threads are waiting for results from some other thread, and no thread can make progress. Programs may also *livelock*, in which processing is occurring and messages are being sent between threads, but no useful work is being performed.

## Events

One recurring idiom in .NET programming (and, for example, JavaScript) is that of *events*. An event is something you can listen to by registering a callback with the event. For example, here's how you can create a WinForms form and listen to mouse clicks on the form:

---

```
> open System.Windows.Forms;;

> let form = new Form(Text = "Click Form", Visible = true, TopMost = true);;

val form : Form = System.Windows.Forms.Form, Text: Click Form

> form.Click.Add(fun evArgs -> printfn "Clicked!");;
```

---

When you run this code in F# Interactive, a window appears; and each time you click the window with the mouse, you see “Clicked!” printed to the console. In .NET terminology, `form.Click` is an event, and `form.Click.Add` registers an event handler, also known as callback, with the event. You can register multiple callbacks with the same event, and many objects publish many events. For example, when you add the following, you see a stream of output when you move the mouse over the form:

```
> form.MouseMove.Add(fun args -> printfn "Mouse, (X, Y) = (%A, %A)" args.X args.Y);;
```

If necessary, you can remove event handlers by first adding them using the `AddHandler` method and then removing them by using `RemoveHandler`.

The process of clicking the form *triggers* (or fires) the event, which means that the callbacks are called in the order they were registered. Events can't be triggered from the outside. In other words, you can't trigger the `Click` event on a form; you can only handle it. Events also have *event arguments*. In the first example shown previously, the event arguments are called `evArgs`, and they are ignored. .NET events usually pass arguments of type `System.EventArgs` or some related type, such as `System.Windows.Forms.MouseEventArgs` or `System.Windows.Forms.PaintEventArgs`. These arguments usually carry pieces of information. For example, a value of type `MouseEventArgs` has the properties `Button`, `Clicks`, `Delta`, `Location`, `X`, and `Y`.

---

■ **Note:** NET event handlers also have an argument meant to bring information about the object source of the event. F# hides this argument in the process of making events first class and allowing their composition, as is explained later.

---

Events occur throughout the design of the .NET class libraries. Table 11-1 shows some of the more important events.

*Table 11-1. A selection of events from the .NET libraries*

Type	Some Sample Events
<code>System.AppDomain</code>	<code>AssemblyLoad</code> , <code>AssemblyResolve</code> , <code>DomainUnload</code> , <code>ProcessExit</code> , <code>UnhandledException</code> (and others)
<code>System.Diagnostics.Process</code>	<code>ErrorDataReceived</code> , <code>Exited</code> , <code>OutputDataReceived</code> (and others)
<code>System.IO.FileSystemWatcher</code>	<code>Changed</code> , <code>Created</code> , <code>Deleted</code> , <code>Error</code> , <code>Renamed</code> (and others)

Type	Some Sample Events
<code>System.Windows.Forms.Control</code>	<code>BackgroundImageChanged</code> , <code>Click</code> , <code>Disposed</code> , <code>DragDrop</code> , <code>KeyPress</code> , <code>KeyUp</code> , <code>KeyDown</code> , <code>Layout</code> , <code>LostFocus</code> , <code>MouseClicked</code> , <code>MouseDown</code> , <code>MouseEnter</code> , <code>MouseHover</code> , <code>MouseLeave</code> , <code>MouseUp</code> , <code>Paint</code> , <code>Resize</code> , <code>TextChanged</code> , <code>Validated</code> , <code>Validating</code> (and others)
<code>System.Windows.Forms.Timer</code>	<code>Tick</code>
<code>System.Timers.Timer</code>	<code>Elapsed</code>

## Events as First-Class Values

In F#, an event such as `form.Click` is a *first-class value*, which means you can pass it around like any other value. The main advantage this brings is that you can use the combinators in the F# library module `Microsoft.FSharp.Control.Event` to map, filter, and otherwise transform the event stream in compositional ways. For example, the following code filters the event stream from `form.MouseMove` so that only events with `X > 100` result in output to the console:

```
form.MouseMove
  |> Event.filter (fun args -> args.X > 100)
  |> Event.listen (fun args -> printfn "Mouse, (X, Y) = (%A, %A)" args.X args.Y)
```

If you work with events a lot, you find yourself factoring out useful portions of code into functions that preprocess event streams. Table 11-2 shows some functions from the F# Event module. One interesting combinator is `Event.partition`, which splits an event into two events based on a predicate.

*Table 11-2. Some functions from the event module*

Function	Type
<code>Event.choose</code>	<code>:'T -&gt; 'U option -&gt; IEvent&lt;'T&gt; -&gt; IEvent&lt;'U&gt;</code>
<code>Event.create</code>	<code>: unit -&gt; ('T -&gt; unit) * IEvent&lt;'T&gt;</code>
<code>Event.filter</code>	<code>:'T -&gt; bool -&gt; IEvent&lt;'T&gt; -&gt; IEvent&lt;'T&gt;</code>
<code>Event.scan</code>	<code>:'U -&gt; 'T -&gt; 'U -&gt; 'U -&gt; IEvent&lt;'T&gt; -&gt; IEvent&lt;'U&gt;</code>
<code>Event.listen</code>	<code>:'T -&gt; unit -&gt; IEvent&lt;'T&gt; -&gt; unit</code>
<code>Event.map</code>	<code>:'T -&gt; 'U -&gt; IEvent&lt;'T&gt; -&gt; IEvent&lt;'U&gt;</code>
<code>Event.partition</code>	<code>:'T -&gt; bool -&gt; IEvent&lt;'T&gt; -&gt; IEvent&lt;'T&gt; * IEvent&lt;'T&gt;</code>

## Creating and Publishing Events

As you write code in F#, particularly object-oriented code, you need to implement, publish, and trigger events. The normal idiom for doing this is to call `new Event<_>()`. Listing 11-1 shows how to define an event object that is triggered at random intervals.

*Listing 11-1. Creating a `RandomTicker` that defines, publishes, and triggers an event*

```
open System
open System.Windows.Forms
```

```

type RandomTicker(approxInterval) =
    let timer = new Timer()
    let rnd = new System.Random(99)
    let tickEvent = new Event<int> ()

    let chooseInterval() : int =
        approxInterval + approxInterval / 4 - rnd.Next(approxInterval / 2)

    do timer.Interval <- chooseInterval()

    do timer.Tick.Add(fun args ->
        let interval = chooseInterval()
        tickEvent.Trigger interval;
        timer.Interval <- interval)

    member x.RandomTick = tickEvent.Publish
    member x.Start() = timer.Start()
    member x.Stop() = timer.Stop()
    interface IDisposable with
        member x.Dispose() = timer.Dispose()

```

Here's how you can instantiate and use this type:

---

```

> let rt = new RandomTicker(1000);;

val rt : RandomTicker

> rt.RandomTick.Add(fun nextInterval -> printfn "Tick, next = %A" nextInterval);;

> rt.Start();;

Tick, next = 1072
Tick, next = 927
Tick, next = 765
...

> rt.Stop();;

```

---

Events are idioms understood by all .NET languages. F# event values are immediately compiled in the idiomatic .NET form. This is because F# allows you to go one step further and use events as first-class values. If you need to ensure that your events can be used by other .NET languages, do both of the following:

- Create the events using `new Event<DelegateType, Args>` instead of `new Event<Args>`.
- Publish the event as a property of a type with the [`<CLIEvent>`] attribute.

Events are used in most of the later chapters of this book, and you can find many examples there.

---

■ **Note:** Because events allow you to register callbacks, it's sometimes important to be careful about the thread on which an event is being raised. This is particularly true when you're programming with multiple threads or the .NET thread pool. Events are usually fired on the GUI thread of an application.

---

## Using and Designing Background Workers

One of the easiest ways to get going with concurrency and parallelism is to use the `System.ComponentModel.BackgroundWorker` class of the .NET Framework. A `BackgroundWorker` class runs on its own dedicated operating system thread. These objects can be used in many situations, but they are especially useful for coarse-grained concurrency and parallelism, such as checking the spelling of a document in the background. This section shows some simple uses of `BackgroundWorker` and how to build similar objects that use `BackgroundWorker` internally.

Listing 11-2 shows a simple use of `BackgroundWorker` that computes the Fibonacci numbers on the worker thread.

### *Listing 11-2. A simple BackgroundWorker*

```
open System.ComponentModel
open System.Windows.Forms

let worker = new BackgroundWorker()
let numIterations = 1000

worker.DoWork.Add(fun args ->

    let rec computeFibonacci resPrevPrev resPrev i =
        // Compute the next result
        let res = resPrevPrev + resPrev

        // At the end of the computation write the result into mutable state
        if i = numIterations then
            args.Result <- box res
        else
            // Compute the next result
            computeFibonacci resPrev res (i + 1)

    computeFibonacci 1 1 2)

worker.RunWorkerCompleted.Add(fun args ->
    MessageBox.Show(sprintf "Result = %A" args.Result) |> ignore)

// Execute the worker
worker.RunWorkerAsync()
```

Table 11-3 shows the primary members of a `BackgroundWorker` object. The execution sequence of the code in Listing 11-2 is:

1. The main application thread creates and configures a `BackgroundWorker` object.
2. After configuration is complete, the main application thread calls the `RunWorkerAsync` method on the `BackgroundWorker` object. This causes the `DoWork` event to be raised on the worker thread.
3. The `DoWork` event handler is executed in the worker thread and computes the 1,000th Fibonacci number. At the end of the computation, the result is written into `args.Result`, a mutable storage location, in the event arguments for the `DoWork` event. The `DoWork` event handler then completes.
4. At some point after the `DoWork` event handler completes, the `RunWorkerCompleted` event is automatically raised on the main application thread. This displays a message box with the result of the computation, retrieved from the `args` field of the event arguments.

*Table 11-3. Primary members of the `BackgroundWorker` class*

Member and Usage	Description
<code>worker.RunWorkerAsync()</code>	Starts the process on a separate thread asynchronously. Called from the main thread.
<code>worker.CancelAsync()</code>	Sets the <code>CancellationPending</code> flag of the background task. Called from the main thread.
<code>worker.CancellationPending</code>	Set to <code>true</code> by raising <code>CancelAsync</code> . Used by the worker thread.
<code>worker.WorkerReportsProgress</code>	Set to <code>true</code> if the worker can support progress updates. Used by the main thread.
<code>worker.WorkerSupportsCancellation</code>	Set to <code>true</code> if the worker can support cancellation of the current task in progress. Used by the main thread.
<code>worker.ReportProgress(count)</code>	Indicates the progress of the operation. Used by the worker thread.
<code>worker.DoWork</code>	Event fires in response to a call to <code>RunWorkerAsync</code> . Invoked on the worker thread.
<code>worker.RunWorkerCompleted</code>	Event fires when the background operation is canceled, when the operation is completed, or when an exception is thrown. Invoked on the main thread.
<code>worker.ProgressChanged</code>	Event fires whenever the <code>ReportProgress</code> property is set. Invoked on the main thread.

■ **Note:** An object such as a `BackgroundWorker` is two-faced: it has some methods and events that are for use from the main thread and some that are for use on the worker thread. This is common in concurrent programming. In particular, understand which thread an event is raised on. For `BackgroundWorker`, the `RunWorkerAsync` and `CancelAsync` methods are for use from the GUI thread, and the `ProgressChanged` and `RunWorkerCompleted` events are raised on the GUI thread. The `DoWork` event is raised on the worker thread, and the `ReportProgress` method and the `CancellationPending` property are for use from the worker thread when handling this event.

The members in Table 11-3 show two additional facets of `BackgroundWorker` objects: they can optionally support protocols for both cancellation and for reporting progress. To report progress



percentages, a worker must call the `ReportProgress` method, which raises the `ProgressChanged` event in the GUI thread. For cancellation, a worker computation need only check the `CancellationPending` property at regular intervals, exiting the computation as a result.

## Building a Simpler Iterative Worker

Capturing common control patterns, such as cancellation and progress reporting, is an essential part of mastering concurrent programming. One problem with .NET classes such as `BackgroundWorker`, however, is that they're often more imperative than you may want, and they force other common patterns to be captured by using mutable data structures shared between threads. This leads to the more difficult topic of shared-memory concurrency, discussed later in this chapter. Furthermore, the way `BackgroundWorker` handles cancellation means that you must insert flag-checks and early-exit paths in the executing background process. Finally, `BackgroundWorker` isn't useful for background threads that perform asynchronous operations, because the background thread exits too early, before the callbacks for the asynchronous operations have executed.

For this reason, it can often be useful to build abstractions that are similar to `BackgroundWorker` but that capture richer or different control patterns, preferably in a way that doesn't rely on the use of mutable state and that interferes less with the structure of the overall computation. Much of the rest of this chapter looks at various techniques to build these control structures.

You start with a case study in which you build a type `IterativeBackgroundWorker` that represents a variation on the `BackgroundWorker` design pattern. Listing 11-3 shows the code.

*Listing 11-3. A variation on the `BackgroundWorker` design pattern for iterative computations*

```
open System.ComponentModel
open System.Windows.Forms

/// An IterativeBackgroundWorker follows the BackgroundWorker design pattern
/// but instead of running an arbitrary computation it iterates a function
/// a fixed number of times and reports intermediate and final results.
/// The worker is paramaterized by its internal state type.
///
/// Percentage progress is based on the iteration number. Cancellation checks
/// are made at each iteration. Implemented via an internal BackgroundWorker.
type IterativeBackgroundWorker<'T>(oneStep : ('T -> 'T),
                                   initialState : 'T,
                                   numIterations : int) =

    let worker =          new BackgroundWorker(WorkerReportsProgress = true,
                                              WorkerSupportsCancellation = true)

    // Create the events that we will later trigger
    let completed = new Event<_>()
    let error = new Event<_>()
    let cancelled = new Event<_>()
    let progress = new Event<_>()

    do worker.DoWork.Add(fun args ->
        // This recursive function represents the computation loop.
```

```

// It runs at "maximum speed", i.e., is an active rather than
// a reactive process, and can only be controlled by a
// cancellation signal.
let rec iterate state i =
    // At the end of the computation, terminate the recursive loop
    if worker.CancellationPending then
        args.Cancel <- true
    elif i < numIterations then
        // Compute the next result
        let state' = oneStep state

        // Report the percentage computation and the internal state
        let percent = int ((float (i + 1) / float numIterations) * 100.0)
        do worker.ReportProgress(percent, box state);

        // Compute the next result
        iterate state' (i + 1)
    else
        args.Result <- box state

iterate initialState 0)

do worker.RunWorkerCompleted.Add(fun args ->
    if args.Cancelled then cancelled.Trigger()
    elif args.Error <> null then error.Trigger args.Error
    else completed.Trigger (args.Result :?> 'T))

do worker.ProgressChanged.Add(fun args ->
    progress.Trigger (args.ProgressPercentage,(args.UserState :?> 'T)))

member x.WorkerCompleted = completed.Publish
member x.WorkerCancelled = cancelled.Publish
member x.WorkerError = error.Publish
member x.ProgressChanged = progress.Publish

// Delegate the remaining members to the underlying worker
member x.RunWorkerAsync() = worker.RunWorkerAsync()
member x.CancelAsync() = worker.CancelAsync()
The types inferred for the code in Listing 11-3 are:

```

---

```

type IterativeBackgroundWorker<'T> =
    class
        new : oneStep:(('T -> 'T) * initialState:'T * numIterations:int ->
            IterativeBackgroundWorker<'T>
        member CancelAsync : unit -> unit
        member RunWorkerAsync : unit -> unit
        member ProgressChanged : IEvent<int * 'T>
        member WorkerCancelled : IEvent<unit>
        member WorkerCompleted : IEvent<'T>

```

```

    member WorkerError : IEvent<exn>
end

```

---

Let's look at this signature first, because it represents the design of the type. The worker constructor is given a function of type 'State -> 'State to compute successive iterations of the computation, plus an initial state and the number of iterations to compute. For example, you can compute the Fibonacci numbers using the iteration function:

```
let fibOneStep (fibPrevPrev : bigint, fibPrev) = (fibPrev, fibPrevPrev + fibPrev);;
```

The type of this function is:

```

val fibOneStep :
    fibPrevPrev:bigint * fibPrev:Numerics.BigInteger ->
    Numerics.BigInteger * Numerics.BigInteger

```

---

The RunWorkerAsync and CancelAsync members follow the BackgroundWorker design pattern, as do the events, except that you expand the RunWorkerCompleted event into three events to correspond to the three termination conditions and modify the ProgressChanged to include the state. You can instantiate the type as:

```
> let worker = new IterativeBackgroundWorker<_>(fibOneStep, (1I, 1I), 100);;
```

```
val worker : IterativeBackgroundWorker<bigint * Numerics.BigInteger>
```

```
> worker.WorkerCompleted.Add(fun result ->
    MessageBox.Show(sprintf "Result = %A" result) |> ignore);;
```

```
> worker.ProgressChanged.Add(fun (percentage, state) ->
    printfn "%d%% complete, state = %A" percentage state);;
```

```
> worker.RunWorkerAsync();;
```

```
1% complete, state = (1I, 1I)
```

```
2% complete, state = (1I, 2I)
```

```
3% complete, state = (2I, 3I)
```

```
4% complete, state = (3I, 5I)
```

```
...
```

```
98% complete, state = (135301852344706746049I, 218922995834555169026I)
```

```
99% complete, state = (218922995834555169026I, 354224848179261915075I)
```

```
100% complete, state = (354224848179261915075I, 573147844013817084101I)
```

---

One difference here is that cancellation and percentage progress reporting are handled automatically, based on the iterations of the computation. This is assuming that each iteration takes roughly the same amount of time. Other variations on the BackgroundWorker design pattern are possible. For example, reporting percentage completion of fixed tasks such as installation is often performed by timing sample executions of the tasks and adjusting the percentage reports appropriately.

---

■ **Note:** You implement `IterativeBackgroundWorker` via delegation rather than inheritance. This is because its external members are different from those of `BackgroundWorker`. The .NET documentation recommends that you use implementation inheritance for this, but we disagree. Implementation inheritance can only *add* complexity to the signature of an abstraction and never makes things simpler, whereas an `IterativeBackgroundWorker` is in many ways simpler than using a `BackgroundWorker`, despite the fact that it uses an instance of the latter internally. Powerful, compositional, simple abstractions are the primary building blocks of functional programming.

---

## Raising Additional Events from Background Workers

Often, you need to raise additional events from objects that follow the `BackgroundWorker` design pattern. For example, let's say you want to augment `IterativeBackgroundWorker` to raise an event when the worker starts its work and for this event to pass the exact time that the worker thread started as an event argument. Listing 11-4 shows the extra code you need to add to the `IterativeBackgroundWorker` type to make this happen. You use this extra code in the next section.

*Listing 11-4. Code to raise GUI-thread events from an `IterativeBackgroundWorker` object*

```
open System
open System.Threading

// Pseudo-code for adding event-raising to this object
type IterativeBackgroundWorker<'T>(...) =

    let worker = ...

    // The constructor captures the synchronization context. This allows us to post
    // messages back to the GUI thread where the BackgroundWorker was created.
    let syncContext = SynchronizationContext.Current
    do if syncContext = null then failwith "no synchronization context found"

    let started = new Event<_>()

    // Raise the event when the worker starts. This is done by posting a message
    // to the captured synchronization context.
    do worker.DoWork.Add(fun args ->
        syncContext.Post(SendOrPostCallback(fun _ -> started.Trigger(DateTime.Now)),
            state = null)

        ...

    /// The Started event gets raised when the worker starts. It is
    /// raised on the GUI thread (i.e. in the synchronization context of
    /// the thread where the worker object was created).
    // It has type IEvent<DateTime>
    member x.Started = started.Publish
```

The simple way to raise additional events is often wrong. For example, it's tempting to create an event, arrange for it to be triggered, and publish it, as you would do for a GUI control. If you do that, however, you end up triggering the event on the background worker thread, and its event handlers run on that thread.

This is dangerous, because most GUI objects, and many other objects, can be accessed only from the thread they were created on; this is a restriction enforced by most GUI systems.

---

■ **Note:** One nice feature of the `BackgroundWorker` class is that it automatically arranges to raise the `RunWorkerCompleted` and `ProgressChanged` events on the GUI thread. Listing 11-4 shows how to achieve this. Technically speaking, the extended `IterativeBackgroundWorker` object captures the *synchronization context* of the thread where it was created and posts an operation back to that synchronization context. A synchronization context is an object that lets you post operations back to another thread. For threads such as a GUI thread, this means that posting an operation posts a message through the GUI event loop.

---

## Connecting a Background Worker to a GUI

To round off this section on the `BackgroundWorker` design pattern, Listing 11-5 shows the full code required to build a small application with a background worker task that supports cancellation and reports progress.

*Listing 11-5. Connecting an `IterativeBackgroundWorker` to a GUI*

```
open System.Drawing
open System.Windows.Forms

let form = new Form(Visible = true, TopMost = true)

let panel = new FlowLayoutPanel(Visible = true,
                               Height = 20,
                               Dock = DockStyle.Bottom,
                               BorderStyle = BorderStyle.FixedSingle)

let progress = new ProgressBar(Visible = false,
                               Anchor = (AnchorStyles.Bottom ||| AnchorStyles.Top),
                               Value = 0)

let text = new Label(Text = "Paused",
                    Anchor = AnchorStyles.Left,
                    Height = 20,
                    TextAlign = ContentAlignment.MiddleLeft)

panel.Controls.Add(progress)
panel.Controls.Add(text)
form.Controls.Add(panel)

let fibOneStep (fibPrevPrev : bigint, fibPrev) = (fibPrev, fibPrevPrev + fibPrev)

// Run the iterative algorithm 500 times before reporting intermediate results
let rec repeatMultipleTimes n f s =
    if n <= 0 then s else repeatMultipleTimes (n - 1) f (f s)
```

```

// Burn some additional cycles to make sure it runs slowly enough
let rec burnSomeCycles n f s =
    if n <= 0 then f s else ignore (f s); burnSomeCycles (n - 1) f s

let step = (repeatMultipleTimes 500 (burnSomeCycles 1000 fibOneStep))

// Create the iterative worker.
let worker = new IterativeBackgroundWorker<_>(step, (1I, 1I), 80)

worker.ProgressChanged.Add(fun (progressPercentage, state)->
    progress.Value <- progressPercentage)

worker.WorkerCompleted.Add(fun (_, result) ->
    progress.Visible <- false;
    text.Text <- "Paused";
    MessageBox.Show(sprintf "Result = %A" result) |> ignore)

worker.WorkerCancelled.Add(fun () ->
    progress.Visible <- false;
    text.Text <- "Paused";
    MessageBox.Show(sprintf "Cancelled OK!") |> ignore)

worker.WorkerError.Add(fun exn ->
    text.Text <- "Paused";
    MessageBox.Show(sprintf "Error: %A" exn) |> ignore)

form.Menu <- new MainMenu()
let workerMenu = form.Menu.MenuItems.Add("&Worker")

workerMenu.MenuItems.Add(new MenuItem("Run", onClick = (fun _ args ->
    text.Text <- "Running";
    progress.Visible <- true;
    worker.RunWorkerAsync()))))

workerMenu.MenuItems.Add(new MenuItem("Cancel", onClick = (fun _ args ->
    text.Text <- "Cancelling";
    worker.CancelAsync()))))

form.Closed.Add(fun _ -> worker.CancelAsync())

```

When you run the code in F# Interactive, a window appears, as shown in Figure 11-1.

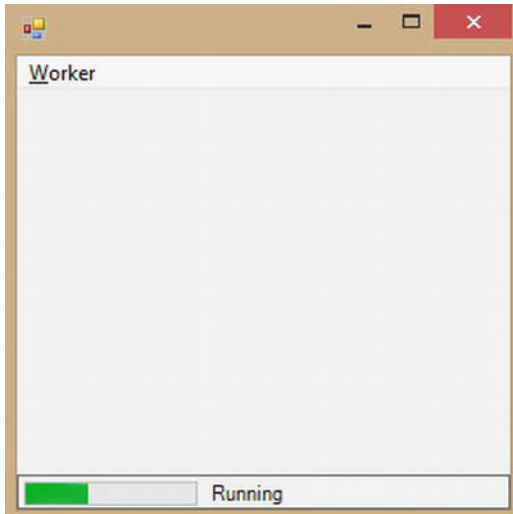

Figure 11-1. A GUI window with a `BackgroundWorker` reporting progress percentage

---

■ **Note:** Forcibly aborting computations uncooperatively isn't recommended in .NET programming. You can attempt to do this using `System.Threading.Thread.Abort()`, but this may have many unintended consequences, discussed later in this chapter.

---

## Introducing Asynchronous and Parallel Computations

The two background worker samples shown so far run at full throttle. In other words, the computations run on the background threads as active loops, and their reactive behavior is limited to flags that check for cancellation. In reality, background threads often have to do different kinds of work: by responding to completed asynchronous I/O requests, by processing messages, by sleeping, or by waiting to acquire shared resources. Fortunately, F# comes with a powerful set of techniques for structuring asynchronous programs in a natural way. These are called *asynchronous workflows*. The next three sections cover how to use asynchronous workflows to structure asynchronous and message-processing tasks in ways that preserve the essential logical structure of your code.

### Fetching Multiple Web Pages in Parallel, Asynchronously

One of the most intuitive asynchronous tasks is fetching a Web page; we all use Web browsers that can fetch multiple pages simultaneously. The samples in Chapter 2 show how to fetch pages synchronously. This is useful for many purposes, but browsers and high-performance Web crawlers have tens or thousands of connections in flight at once.

The type `Microsoft.FSharp.Control.Async<'T>` lies at the heart of F# asynchronous workflows. A value of type `Async<'T>` represents a program fragment that will generate a value of type `'T` at some point in the future. Listing 11-6 shows how to use asynchronous workflows to fetch several Web pages simultaneously.

*Listing 11-6. Fetching three Web pages simultaneously*

```

open System.Net
open System.IO

let museums = ["MOMA", "http://moma.org/";
               "British Museum", "http://www.thebritishmuseum.ac.uk/";
               "Prado", "http://www.museodelprado.es/"]

let fetchAsync(nm, url : string) = async {
    printfn "Creating request for %s..." nm
    let req = WebRequest.Create(url)

    let! resp = req.AsyncGetResponse()

    printfn "Getting response stream for %s..." nm
    let stream = resp.GetResponseStream()

    printfn "Reading response for %s..." nm
    let reader = new StreamReader(stream)
    let! html = reader.AsyncReadToEnd()

    printfn "Read %d characters for %s..." html.Length nm}

Async.Parallel [for nm, url in museums -> fetchAsync(nm, url)]
    |> Async.Ignore
    |> Async.RunSynchronously

```

The types of these functions and values are:

---

```

val museums : (string * string) list
val fetchAsync : nm:string * url:string -> Async<unit>

```

---

When run on one of our machines via F# Interactive, the output of the code from Listing 11-6 is:

---

```

Creating request for MOMA...
Creating request for British Museum...
Creating request for Prado...
Getting response for MOMA...
Reading response for MOMA...
Getting response for Prado...
Reading response for Prado...
Read 188 characters for Prado...
Read 41635 characters for MOMA...
Getting response for British Museum...
Reading response for British Museum...
Read 24341 characters for British Museum...

```

---

The heart of the code in Listing 11-6 is the construct introduced by `async { ... }`. This is an application of the workflow syntax that is covered in Chapter 17.



Let's take a closer look at Listing 11-6. The key operations are the two `let!` operations within the workflow expression:

```
async { ...
    let! resp = req.AsyncGetResponse()
    ...
    let! html = reader.AsyncReadToEnd()
    ... }
```

Within asynchronous workflow expressions, the language construct `let! var = expr in body` means “perform the asynchronous operation `expr` and bind the result to `var` when the operation completes. Then, continue by executing the rest of the computation body.”

With this in mind, you can now see what `fetchAsync` does:

- It synchronously requests a Web page.
- It asynchronously awaits a response to the request.
- It gets the response `Stream` and `StreamReader` synchronously after the asynchronous request completes.
- It reads to the end of the stream asynchronously.
- After the read completes, it prints the total number of characters read synchronously.

Finally, you use the method `Async.RunSynchronously` to initiate the execution of a number of asynchronous computations. This works by queueing the computations in the .NET thread pool. The following section explains the .NET thread pool in more detail.

## Understanding Thread Hopping

Asynchronous computations are different from normal, synchronous computations: an asynchronous computation tends to hop between different underlying .NET threads. To see this, let's augment the asynchronous computation with diagnostics that show the ID of the underlying .NET thread at each point of active execution. You can do this by replacing uses of `printfn` in the function `fetchAsync` with uses of the function:

```
let tprintfn fmt =
    printf "[.NET Thread %d]" System.Threading.Thread.CurrentThread.ManagedThreadId;
    printfn fmt
```

After doing this, the output changes to:

---

```
[.NET Thread 12]Creating request for MOMA...
[.NET Thread 13]Creating request for British Museum...
[.NET Thread 12]Creating request for Prado...
[.NET Thread 8]Getting response for MOMA...
[.NET Thread 8]Reading response for MOMA...
[.NET Thread 9]Getting response for Prado...
[.NET Thread 9]Reading response for Prado...
[.NET Thread 9]Read 188 characters for Prado...
[.NET Thread 8]Read 41635 characters for MOMA...
[.NET Thread 8]Getting response for British Museum...
```

```
[.NET Thread 8]Reading response for British Museum...
[.NET Thread 8]Read 24341 characters for British Museum...
```

---

Note how each individual Async program hops between threads; the MOMA request started on .NET thread 12 and finished life on .NET thread 8. Each asynchronous computation in Listing 11-6 executes in the same way:

- It starts life as a work item in the .NET thread pool. (The .NET thread pool is explained in “What Is the .NET Thread Pool?” These are processed by a number of .NET threads.
  - When the asynchronous computations reach the `AsyncGetResponse` and `AsyncReadToEnd` calls, the requests are made, and the continuations are registered as I/O completion actions in the .NET thread pool. No thread is used while the request is in progress.
  - When the requests complete, they trigger a callback in the .NET thread pool. These may be serviced by threads other than those that originated the calls.
- 

### WHAT IS THE .NET THREAD POOL?

---

.NET objects such as `BackgroundWorker` use a single .NET background thread, which corresponds to a single Windows or other OS thread. OS threads have supporting resources, such as an execution stack, that consume memory and are relatively expensive to create and run.

Many concurrent processing tasks, however, require only the ability to schedule short-lived tasks that then suspend, waiting for further input. To simplify the process of creating and managing these tasks, the .NET Framework provides the `System.Threading.ThreadPool` class. The thread pool consists of two main sets of suspended tasks: a queue containing user work items and a pool of I/O completion callbacks, each waiting for a signal from the operating system. The number of threads in the thread pool is automatically tuned, and items can be either queued asynchronously or registered against a .NET `WaitHandle` synchronization object (for example, a lock, a semaphore, or an I/O request). This is how to queue a work item in the .NET thread pool:

```
open System.Threading
ThreadPool.QueueUserWorkItem(fun _ -> printf "Hello!") |> ignore
```

---

## Under the Hood: What Are Asynchronous Computations?

`Async<'T>` values, the result of async workflows, are essentially a way of writing continuation-passing or callback programs explicitly. Continuations themselves were described in Chapter 9 along with techniques to pass them explicitly. `Async<'T>` computations call a *success continuation* when the asynchronous computation completes and an *exception continuation* if it fails. They provide a form of *managed asynchronous computation*, in which *managed* means that several aspects of asynchronous programming are handled automatically:

- *Exception propagation is added for free*: If an exception is raised during an asynchronous step, the exception terminates the entire asynchronous computation and cleans up any resources declared using `use`, and the exception value is then

handed to a continuation. Exceptions may also be caught and managed within the asynchronous workflow by using `try/with/finally`.

- *Cancellation checking is added for free:* The execution of an `Async<'T>` workflow automatically checks a cancellation flag at each asynchronous operation. Cancellation can be controlled through the use of cancellation tokens.
- *Resource lifetime management is fairly simple:* You can protect resources across parts of an asynchronous computation by using `use` inside the workflow syntax.

If you put aside the question of cancellation, values of type `Async<'T>` are effectively identical to the type:

```
type Async<'T> = Async of ('T -> unit) * (exn -> unit) -> unit
```

Here, the functions are the success continuation and exception continuations, respectively. Each value of type `Async<'T>` should eventually call one of these two continuations. The `async` object is of type `AsyncBuilder` and supports the following methods, among others:

---

```
type AsyncBuilder with
    member Return : value: 'T -> Async<'T>
    member Delay : generator:(unit -> Async<'T>) -> Async<'T>
    member Using: resource:'T * binding:(('T -> Async<'U>) -> Async<'U>) when 'T :> System.
IDisposable
    member Bind: computation:Async<'T> * binder:(('T -> Async<'U>) -> Async<'U>
```

---

The full definition of `Async<'T>` values and the implementations of these methods for the `async` object are given in the F# library source code. Builder objects, such as `async`, that contain methods like those shown previously mean that you can use the syntax `async { ... }` as a way of building `Async<'T>` values (see Chapter 17 for more on builder objects).

Table 11-4 shows the common constructs used in asynchronous workflow expressions. For example, the asynchronous workflow

```
async {let req = WebRequest.Create("http://moma.org/")
    let! resp = req.AsyncGetResponse()
    let stream = resp.GetResponseStream()
    let reader = new StreamReader(stream)
    let! html = reader.AsyncReadToEnd()
    html}
```

is shorthand for the code

```
async.Delay(fun () ->
    let req = WebRequest.Create("http://moma.org/")
    async.Bind(req.AsyncGetResponse(), (fun resp ->
        let stream = resp.GetResponseStream()
        let reader = new StreamReader(stream)
        async.Bind(reader.AsyncReadToEnd(), (fun html ->
            async.Return html))))))
```

As you will see in Chapter 17, the key to understanding the F# workflow syntax is always to understand the meaning of `let!`. In the case of `async` workflows, `let!` executes one asynchronous computation and schedules the next computation for execution after the first asynchronous computation completes. This is syntactic sugar for the `Bind` operation on the `async` object.

**Table 11-4.** Common constructs used in `async { ... }` workflow expressions

Construct	Description
<code>let! pat = expr</code>	Executes the asynchronous computation <code>expr</code> , and binds its result to <code>pat</code> when it completes. If <code>expr</code> has type <code>Async&lt;'T&gt;</code> , then <code>pat</code> has type <code>'T</code> . Equivalent to <code>async.Bind(expr, (fun pat -&gt; ...))</code> .
<code>let pat = expr</code>	Executes an expression synchronously, and binds its result to <code>pat</code> immediately. If <code>expr</code> has type <code>'T</code> , <code>pat</code> has type <code>'T</code> .
<code>do! expr</code>	Equivalent to <code>let! () = expr</code> .
<code>do expr</code>	Equivalent to <code>let () = expr</code> .
<code>return expr</code>	Evaluates the expression and returns its value as the result of the containing asynchronous workflow. Equivalent to <code>async.Return(expr)</code> .
<code>return! expr</code>	Executes the expression as an asynchronous computation, and returns its result as the overall result of the containing asynchronous workflow. Equivalent to <code>expr</code> .
<code>use pat = expr</code>	Executes the expression immediately and binds its result immediately. Calls the <code>Dispose</code> method on each variable bound in the pattern when the subsequent asynchronous workflow terminates, regardless of whether it terminates normally or by an exception. Equivalent to <code>async.Using(expr, (fun pat -&gt; ...))</code> .

## Parallel File Processing Using Asynchronous Workflows

This section shows a slightly longer example of asynchronous I/O processing. The running sample is an application that must read a large number of image files and perform some processing on them. This kind of application may be *compute bound* (if the processing takes a long time and the file system is fast) or *I/O bound* (if the processing is quick and the file system is slow). Using asynchronous techniques tends to give good overall performance gains when an application is I/O bound and can also give performance improvements for compute-bound applications if asynchronous operations are executed in parallel on multicore machines.

Listing 11-7 shows a synchronous implementation of the image-transformation program.

**Listing 11-7.** A synchronous image processor

```
open System.IO
let numImages = 200
let size = 512
let numPixels = size * size

let makeImageFiles () =
    printfn "making %d %dx%d images... " numImages size size
    let pixels = Array.init numPixels (fun i -> byte i)
    for i = 1 to numImages do
        System.IO.File.WriteAllBytes(sprintf "Image%d.tmp" i, pixels)
    printfn "done."

let processImageRepeats = 20

let transformImage (pixels, imageNum) =
    printfn "transformImage %d" imageNum;
    // Perform a CPU-intensive operation on the image.
```

```

    for i in 1 .. processImageRepeats do
        pixels |> Array.map (fun b -> b + 1uy) |> ignore
    pixels |> Array.map (fun b -> b + 1uy)

let processImageSync i =
    use inStream = File.OpenRead(sprintf "Image%d.tmp" i)
    let pixels = Array.zeroCreate numPixels
    let nPixels = inStream.Read(pixels,0,numPixels);
    let pixels' = transformImage(pixels,i)
    use outStream = File.OpenWrite(sprintf "Image%d.done" i)
    outStream.Write(pixels',0,numPixels)

let processImagesSync () =
    printfn "processImagesSync...";
    for i in 1 .. numImages do
        processImageSync(i)

```

You assume the image files already are created using the code:

---

```

> System.Environment.CurrentDirectory <- __SOURCE_DIRECTORY__;
> makeImageFiles();

```

---

You leave the transformation on the image largely unspecified, such as the function `transformImage`. By changing the value of `processImageRepeats`, you can adjust the computation from compute bound to I/O bound.

The problem with this implementation is that each image is read and processed sequentially, when in practice, multiple images can be read and transformed simultaneously, giving much greater throughput. Listing 11-8 shows the implementation of the image processor using an asynchronous workflow.

**Listing 11-8.** *The asynchronous image processor*

```

let processImageAsync i =
    async {use inStream = File.OpenRead(sprintf "Image%d.tmp" i)
        let! pixels = inStream.AsyncRead(numPixels)
        let pixels' = transformImage(pixels, i)
        use outStream = File.OpenWrite(sprintf "Image%d.done" i)
        do! outStream.AsyncWrite(pixels')}

let processImagesAsync() =
    printfn "processImagesAsync...";
    let tasks = [for i in 1 .. numImages -> processImageAsync(i)]
    Async.RunSynchronously (Async.Parallel tasks) |> ignore
    printfn "processImagesAsync finished!"

```

On one of our machines, the asynchronous version of the code ran up to three times as fast as the synchronous version (in total elapsed time) when `processImageRepeats` is 20 and `numImages` is 200. A factor of 2 was achieved consistently for any number of `processImageRepeats`, because this machine had two CPUs.

Let's take a closer look at this code. The call `Async.RunSynchronously (Async.Parallel ...)` executes a set of asynchronous operations in the thread pool, collects their results (or their exceptions), and returns

the overall array of results to the original code. The core asynchronous workflow is introduced by the `async { ... }` construct. Let's look at the inner workflow line by line:

```
async { use inStream = File.OpenRead(sprintf "Image%d.tmp" i)
  ... }
```

This line opens the input stream synchronously using `File.OpenRead`. Although this is a synchronous operation, the use of `use` indicates that the lifetime of the stream is managed over the remainder of the workflow. The stream is closed when the variable is no longer in scope—that is, at the end of the workflow, even if asynchronous activations occur in between. If any step in the workflow raises an uncaught exception, the stream is also closed while handling the exception.

The next line reads the input stream asynchronously using `inStream.AsyncRead`:

```
async { use inStream = File.OpenRead(sprintf "Image%d.tmp" i)
  let! pixels = inStream.AsyncRead(numPixels)
  ... }
```

`Stream.AsyncRead` is an extension method added to the `.NET System.IO.Stream` class defined in the `F#` library, and it generates a value of type `Async<byte[]>`. The use of `let!` executes this operation asynchronously and registers a callback. When the callback is invoked, the value `pixels` is bound to the result of the operation, and the remainder of the asynchronous workflow is executed. The next line transforms the image synchronously using `transformImage`:

```
async { use inStream = File.OpenRead(sprintf "Image%d.tmp" i)
  let! pixels = inStream.AsyncRead(numPixels)
  let pixels' = transformImage(pixels, i)
  ... }
```

Like the first line, the next line opens the output stream. Using `use` guarantees that the stream is closed by the end of the workflow regardless of whether exceptions are thrown in the remainder of the workflow:

```
async { use inStream = File.OpenRead(sprintf "Image%d.tmp" i)
  let! pixels = inStream.AsyncRead(numPixels)
  let pixels' = transformImage(pixels, i)
  use outputStream = File.OpenWrite(sprintf "Image%d.done" i)
  ... }
```

The final line of the workflow performs an asynchronous write of the image. Once again, `AsyncWrite` is an extension method added to the `.NET System.IO.Stream` class defined in the `F#` library:

```
async { use inStream = File.OpenRead(sprintf "Image%d.tmp" i)
  let! pixels = inStream.AsyncRead(numPixels)
  let pixels' = transformImage(pixels,i)
  use outputStream = File.OpenWrite(sprintf "Image%d.done" i)
  do! outputStream.AsyncWrite(pixels') }
```

If you now return to the first part of the function, you can see that the overall operation of the function is to create `numImages` individual asynchronous operations, using a sequence expression that generates a list:

```
let tasks = [ for i in 1 .. numImages -> processImageAsync(i) ]
```

You can compose these tasks in parallel using `Async.Parallel` and then run the resulting process using `Async.RunSynchronously`. This waits for the overall operation to complete and returns the result:

`Async.RunSynchronously` (`Async.Parallel` tasks)

Table 11-5 shows some of the primitives and combinators commonly used to build asynchronous workflows. Take the time to compare Listings 11-8 and 11-7. Notice:

- The overall structure and flow of the core of Listing 11-8 is similar to Listing 11-7: that is, the synchronous algorithm, even though it includes steps executed asynchronously.
- The performance characteristics of Listing 11-8 are the same as those of Listing 11-7. Any overhead involved in executing the asynchronous workflow is easily dominated by the overall cost of I/O and image processing. It's also much easier to experiment with modifications, such as making the write operation synchronous.

*Table 11-5. Some common primitives used to build `Async<T>` values*

Member/Type	Description
<code>Async.FromContinuations(callback)</code>	Builds a single primitive asynchronous step of an asynchronous computation. The function that implements the step is passed continuations to call after the step is complete or if the step fails.
<code>Async.FromBeginEnd(beginAction, endAction)</code>	Builds a single asynchronous computation from a .NET pair of <code>BeginOperation/EndOperation</code> methods.
<code>Async.AwaitTask(task)</code>	Builds a single asynchronous computation from a .NET 4.0 task. .NET tasks are returned by many .NET 4.0 APIs. These represent already-started asynchronous computations.
<code>Async.Parallel(computations)</code>	Builds a single asynchronous computation that runs the given asynchronous computations in parallel and waits for results from all to be returned. Each may either terminate with a value or return an exception. If any raises an exception, then the others are cancelled, and the overall asynchronous computation also raises the same exception.

## Running Asynchronous Computations

Values of type `Async<T>` are usually run using the functions listed in Table 11-6. You have seen samples of `Async.RunSynchronously` earlier in this chapter.

The most important function in this list is `Async.StartImmediate`. This starts an asynchronous computation using the current thread to run the prefix of the computation. For example, if you start an asynchronous computation from a GUI thread, this will run the prefix of the computation on the GUI thread. This should be your primary way of starting asynchronous computations when doing GUI programming or when implementing server-side asynchronous processes using systems such as ASP.NET that have a dedicated “page handling” thread.

*Table 11-6. Common methods in the `Async` type used to run `Async<T>` values*

Member/Type	Description
<code>Async.RunSynchronously(async)</code>	Runs an operation in the thread pool and waits for its result.
<code>Async.Start(async)</code>	Queues the asynchronous computation as an operation in the thread pool.

<code>Async.StartImmediate(async)</code>	Starts the asynchronous computation on the current thread. It will run on the current thread until the first point where a continuation is scheduled for the thread—for example, at a primitive asynchronous I/O operation.
<code>Async.StartChild(async)</code>	Queues the asynchronous computation, initially as a work item in the thread pool, but inherits the cancellation handle from the current asynchronous computation.

---

## Common I/O Operations in Asynchronous Workflows

Asynchronous programming is becoming more widespread because of the use of multicore machines and networks in applications, and many .NET APIs now come with both synchronous and asynchronous versions of their functionality. For example, all Web-service APIs generated by .NET tools have asynchronous versions of their requests. A quick scan of the .NET API documentation on the Microsoft Web site reveals the asynchronous operations listed in Table 11-7. These all have equivalent `Async<'T>` operations defined in the F# libraries as extensions to the corresponding .NET types.

*Table 11-7. Some asynchronous operations in the .NET libraries and corresponding expected F# naming Scheme*

.NET Asynchronous Operation	F# Naming Scheme	Description
<code>Stream.Begin/EndRead</code>	<code>AsyncRead</code>	Reads a stream of bytes asynchronously. See also <code>FileStream</code> , <code>NetworkStream</code> , <code>DeflateStream</code> , <code>IsolatedStorageFileStream</code> , and <code>SslStream</code> .
<code>Stream.Begin/EndWrite</code>	<code>AsyncWrite</code>	Writes a stream of bytes asynchronously. See also <code>FileStream</code> .
<code>Socket.BeginAccept/EndAccept</code>	<code>AsyncAccept</code>	Accepts an incoming network socket request asynchronously.
<code>Socket.BeginReceive/EndReceive</code>	<code>AsyncReceive</code>	Receives data on a network socket asynchronously.
<code>Socket.BeginSend/EndSend</code>	<code>AsyncSend</code>	Sends data on a network socket asynchronously.
<code>WebRequest.Begin/EndGetResponse</code>	<code>AsyncGetResponse</code>	Makes an asynchronous Web request. See also <code>FtpWebRequest</code> , <code>SoapWebRequest</code> , and <code>HttpWebRequest</code> .
<code>SqlCommand.Begin/EndExecuteReader</code>	<code>AsyncExecuteReader</code>	Executes an <code>SqlCommand</code> asynchronously.
<code>SqlCommand.Begin/EndExecuteXmlReader</code>	<code>AsyncExecuteXmlReader</code>	Executes a read of XML asynchronously.
<code>SqlCommand.Begin/EndExecuteNonQuery</code>	<code>AsynExecuteNonQuery</code>	Executes a nonreading <code>SqlCommand</code> asynchronously.

Sometimes, you may need to write a few primitives to map .NET asynchronous operations into the F# asynchronous framework. You will see some examples later in this section.



## Using Tasks with Asynchronous Programming

In C# 5.0 and .NET 4.0, the .NET Framework was updated with asynchronous programming using *tasks*. Tasks represent already-started asynchronous computations, and many tasks are returned by many .NET 4.0 APIs. In F#, the best way to deal with tasks is normally to immediately consume tasks in an asynchronous computation by using `Async.AwaitTask`, and you publish F# asynchronous computations as tasks by using `Async.StartAsTask`.

*Table 11-8. Some methods to consume and produce tasks*

Member/Usage	Description
<code>Async.AwaitTask(task)</code>	Builds a single asynchronous computation that awaits the completion of an already-running .NET 4.0 task
<code>Async.StartAsTask(computation)</code>	Start an asynchronous computation as a .NET 4.0 task

It can also sometimes be useful to program with tasks directly using the library primitives available in the .NET libraries. In particular, tasks support a rich (and somewhat bewildering) number of primitives for controlling timing and scheduling of computations. Examples of doing this can be found in C# programming guides on the web, and they can readily be translated to F#.

## Understanding Exceptions and Cancellation

Two recurring topics in asynchronous programming are exceptions and cancellation. Let's first explore some of the behavior of asynchronous programs with regard to exceptions:

---

```
> let failingTask = async { do failwith "fail" };;
```

```
val failingTask: Async<unit>
```

```
> Async.RunSynchronously failingTask;;
```

```
System.Exception
Stopped due to error
```

```
> let failingTasks = [async {do failwith "fail A"};
                    async {do failwith "fail B"}];;
```

```
val failingTasks : Async<unit> list
```

```
> Async.RunSynchronously (Async.Parallel failingTasks);;
```

```
System.Exception: fail A
stopped due to error
```

```
> Async.RunSynchronously (Async.Parallel failingTasks);;
```

```
System.Exception: fail B
stopped due to error
```

---

From these examples, you can see:

- Tasks fail only when they're actually executed. The construction of a task using the `async { ... }` syntax never fails.
- Tasks that are run using `Async.RunSynchronously` report any failure back to the controlling thread as an exception.
- It's nondeterministic which task will fail first.
- Tasks composed using `Async.Parallel` report the first failure from among the collected set of tasks. An attempt is made to cancel other tasks by setting the cancellation flag for the group of tasks, and any further failures are ignored.

You can wrap a task using the `Async.Catch` combinator. This has the type:

---

```
static member Catch : computation:Async<'T> -> Async<Choice<'T,exn>>
```

---

For example:

---

```
> Async.RunSynchronously (Async.Catch failingTask);;

val it : Choice<unit,exn> =
  Choice2Of2
    System.Exception: fail
```

---

You can also handle errors by using `try/finally` in an `async { ... }` workflow.

## Under the Hood: Implementing `Async.Parallel`

`Async.Parallel` can appear magical. Computation tasks are created, executed, and resynchronized almost without effort. Listing 11-9 shows that a basic implementation of this operator is simple and again helps you see how `Async<'T>` values work under the hood.

*Listing 11-9. A basic implementation of a fork-join parallel operator*

```
let forkJoinParallel(taskSeq) =
  Async.FromContinuations (fun (cont, econt, ccont) ->
    let tasks = Seq.toArray taskSeq
    let count = ref tasks.Length
    let results = Array.zeroCreate tasks.Length
    tasks |> Array.iteri (fun i p ->
      Async.Start
        (async {let! res = p
              results.[i] <- res;
              let n = System.Threading.Interlocked.Decrement(count)
              if n = 0 then cont results})))
```

This basic implementation first converts the input task sequence to an array and then creates mutable state `count` and `results` to record the progress of the parallel computations. It then iterates through the tasks and queues each for execution in the .NET thread pool. Upon completion, each writes its result and decrements the counter using an atomic `Interlocked.Decrement` operator, discussed further in the section

“Using Shared-Memory Concurrency” at the end of this chapter. The last process to finish calls the continuation with the collected results.

In practice, `Async.Parallel` is implemented more efficiently and takes into account exceptions and cancellation; again, see the F# library code for full details.

## Using async for CPU Parallelism with Fixed Tasks

One of the great advantages of F# async programming is that it can be used for both CPU and I/O parallel-programming tasks. For example, you can use it for many CPU parallelism tasks that don't perform any I/O but rather carry out straight CPU-bound computations.

For optimized, partitioned CPU parallelism, this is often done by using `Async.Parallel` with a number of tasks that exactly matches the number of physical processors on a machine. For example, the following code shows parallel initialization of an array in which each cell is filled by running the input function. The implementation of this function makes careful use of shared-memory primitives (a topic discussed later in this book) and is highly efficient:

```
open System.Threading
open System

// Initialize an array by a parallel init using all available processors
// Note, this primitive doesn't support cancellation.
let parallelArrayInit n f =
    let currentLine = ref -1
    let res = Array.zeroCreate n
    let rec loop () =
        let y = Interlocked.Increment(currentLine)
        if y < n then res.[y] <- f y; loop()

    // Start just the right number of tasks, one for each physical CPU
    Async.Parallel [for i in 1 .. Environment.ProcessorCount -> async {do loop()}]
        |> Async.Ignore
        |> Async.RunSynchronously

    res
```

---

```
> let rec fib x = if x < 2 then 1 else fib (x - 1) + fib (x - 2)
> parallelArrayInit 25 (fun x -> fib x);;
```

```
val it : int [] =
    [|1; 1; 2; 3; 5; 8; 13; 21; 34; 55; 89; 144; 233; 377; 610; 987; 1597; 2584;
    4181; 6765; 10946; 17711; 28657; 46368; 75025; 121393; 196418; 317811;
    514229; 832040|]
```

---

## Agents

A distinction is often made between *shared-memory* concurrency and *message passing* concurrency. The former is often more efficient on local machines and is covered in the section “Using Shared-Memory Concurrency” later in this chapter. The latter scales to systems in which there is no shared memory—for example, distributed systems—and also can be used to avoid performance problems associated with shared memory. Asynchronous message passing and processing is a common foundation for concurrent programming, and this section looks at some simple examples of message-passing programs.

## Introducing Agents

In a sense, you've already seen a good deal of message passing in this chapter. For example:

- In the `BackgroundWorker` design pattern, the `CancelAsync` method is a simple kind of message.
- Whenever you raise events on a GUI thread from a background thread, you are, under the hood, posting a message to the GUI's event queue. On Windows, this event queue is managed by the OS, and the processing of the events on the GUI thread is called the *Windows event loop*.

This section covers a simple kind of message processing called *mailbox processing* that's popular in languages such as Erlang. A *mailbox* is a message queue that you can scan for a message that is particularly relevant to the message-processing agent you're defining. Listing 11-10 shows a concurrent agent that implements a simple counter by processing a mailbox as messages arrive. The type `MailboxProcessor` is defined in the F# library—in this book, we use the name `Agent` for this type, through the use of a type alias.

*Listing 11-10. Implementing a counter using an agent*

```
type Agent<'T> = MailboxProcessor<'T>

let counter =
    new Agent<_>(fun inbox ->
        let rec loop n =
            async {printfn "n = %d, waiting..." n
                    let! msg = inbox.Receive()
                    return! loop (n + msg)}
            loop 0)
```

The type of counter is `Agent<int>`, in which the type argument indicates that this object expects to be sent messages of type `int`:

---

```
type Agent<'T> = MailboxProcessor<'T>
val counter : Agent<int>
```

---

The “Message Processing and State Machines” sidebar describes the general pattern of Listing 11-10 and the other `MailboxProcessor` examples in this chapter, all of which can be thought of as *state machines*. With this in mind, let's take a closer look at Listing 11-10. First, let's use counter on some simple inputs:

---

```
> counter.Start();;
n = 0, waiting...

> counter.Post(1);;
n = 1, waiting...

> counter.Post(2);;
n = 3, waiting...

> counter.Post(1);;
n = 4, waiting...
```

---

Looking at Listing 11-10, note that calling the `Start` method causes the processing agent to enter loop with `n = 0`. The agent then performs an asynchronous `Receive` request on the `inbox` for the `MailboxProcessor`; that is, the agent waits asynchronously until a message has been received. When the message `msg` is received, the program calls `loop (n+msg)`. As additional messages are received, the internal counter (actually an argument) is incremented further.

You post messages to the agent using `counter.Post`. The type of `inbox.Receive` is:

---

```
member Receive: ?timeout:int -> Async<'Message>
```

---

Using an asynchronous receive ensures that no real threads are blocked for the duration of the wait. This means the previous techniques scale to many thousands of concurrent agents.

---

## MESSAGE PROCESSING AND STATE MACHINES

---

Listing 11-10 shares a common structure with many of the other message-processing components you see in this chapter, all of which are *state machines*. This general structure is:

```
let agent =
    MailboxProcessor.Start(fun inbox ->

        // The states of the state machine
        let rec state1(args) = async { ... }
        and state2(args) = async { ... }
        ...
        and stateN(args) = async { ... }

        // Enter the initial state
        state1(initialArgs))
```

That is, message-processing components typically use sets of recursive functions, each defining an asynchronous computation. Each of these functions can be thought of as a state, and one of these states is identified as the initial state. You can pass arguments between these states just as you pass them between any other set of recursive functions.

---

## Creating Objects That React to Messages

Often, it's wise to hide the internals of an asynchronous computation behind an object, because the use of message passing can be seen as an implementation detail. Listing 11-10 doesn't show you how to retrieve information from the counter, except by printing it to the standard output. Furthermore, it doesn't show how to ask the processing agent to exit. Listing 11-11 shows how to implement an object wrapping an agent that supports `Increment`, `Stop`, and `Fetch` messages.

*Listing 11-11. Hiding a mailbox and supporting a fetch method*

```

/// The internal type of messages for the agent
type internal msg = Increment of int | Fetch of AsyncReplyChannel<int> | Stop

type CountingAgent() =
    let counter = MailboxProcessor.Start(fun inbox ->
        // The states of the message-processing state machine...
        let rec loop n =
            async {let! msg = inbox.Receive()
                match msg with
                | Increment m ->
                    // increment and continue...
                    return! loop(n + m)
                | Stop ->
                    // exit
                    return ()
                | Fetch replyChannel ->
                    // post response to reply channel and continue
                    do replyChannel.Reply n
                    return! loop n}

            // The initial state of the message-processing state machine...
            loop(0))

    member a.Increment(n) = counter.Post(Increment n)
    member a.Stop() = counter.Post Stop
    member a.Fetch() = counter.PostAndReply(fun replyChannel -> Fetch replyChannel)

```

The inferred public types indicate how the presence of a concurrent agent is successfully hidden by the use of an object:

---

```

type CountingAgent =
    class
        new : unit -> CountingAgent
        member Fetch : unit -> int
        member Increment : n:int -> unit
        member Stop : unit -> unit
    end

```

---

Here, you can see an instance of this object in action:

---

```

> let counter = new CountingAgent();;

val counter : CountingAgent

> counter.Increment(1);;

> counter.Fetch();;
val it : int = 1

> counter.Increment(2);;

> counter.Fetch();;

```

```
val it : int = 3

> counter.Stop();;
```

Listing 11-11 shows several important aspects of message passing and processing using the mailbox-processing model:

- Internal message protocols are often represented using discriminated unions. Here, the type `msg` has cases `Increment`, `Fetch`, and `Stop`, corresponding to the three methods accepted by the object that wraps the overall agent implementation.
- Pattern matching over discriminated unions gives a succinct way to process messages. A common pattern is a call to `inbox.Receive()` or `inbox.TryReceive()` followed by a match on the message contents.
- The `PostAndReply` on the `MailboxProcessor` type gives a way to post a message and wait for a reply. The temporary *reply channel* created should form part of the message. A reply channel is an object of type `Microsoft.FSharp.Control.AsyncReplyChannel<'reply>`, which in turn supports a `Post` method. The `MailboxProcessor` can use this to post a reply to the waiting caller. In Listing 11-11, the channel is sent to the underlying message-processing agent `counter` as part of the `Fetch` message.

Table 11-9 summarizes the most important members available on the `MailboxProcessor` type.

**Table 11-9.** Some members of the `MailboxProcessor<'Message>` type

Member/Usage	Description
<code>agent.Post(message)</code>	Posts a message to a mailbox queue.
<code>agent.Receive(?timeout)</code>	Returns the next message in the mailbox queue. If no messages are present, performs an asynchronous wait until the message arrives. If a timeout occurs, then raises a <code>TimeoutException</code> .
<code>agent.Scan(scanner, ?timeout)</code>	Scans the mailbox for a message in which the function returns a <code>Some(_)</code> value. Returns the chosen result. If no messages are present, performs an asynchronous wait until more messages arrive. If a timeout occurs, then raises a <code>TimeoutException</code> .
<code>agent.TryReceive(?timeout)</code>	Like <code>Receive</code> , but if a timeout occurs, then returns <code>None</code> .
<code>agent.TryScan(scanner, ?timeout)</code>	Like <code>Scan</code> , but if a timeout occurs, then returns <code>None</code> .

## Scanning Mailboxes for Relevant Messages

It's common for a message-processing agent to end up in a state in which it's not interested in all messages that may appear in a mailbox but only in a subset of them. For example, you may be awaiting a reply from another agent and aren't interested in serving new requests. In this case, it's essential that you use `MailboxProcessor.Scan` rather than `MailboxProcessor.Receive`. Table 11-9 shows the signatures of both of these. The former lets you choose between available messages by processing them in order, whereas the latter forces you to process every message. Listing 11-12 shows an example of using `MailboxProcessor.Scan`.

*Listing 11-12. Scanning a mailbox for relevant messages*

```

type Message =
  | Message1
  | Message2 of int
  | Message3 of string

let agent =
  MailboxProcessor.Start(fun inbox ->
    let rec loop() =
      inbox.Scan(function
        | Message1 ->
          Some (async {do printfn "message 1!"
                        return! loop()})
        | Message2 n ->
          Some (async {do printfn "message 2!"
                        return! loop()})
        | Message3 _ ->
          None)
      loop()
  )

```

You can now post these agent messages, including messages of the ignored kind `Message3`:

---

```

> agent.Post(Message1);;
message 1!
val it : unit = ()

> agent.Post(Message2(100));;
message 2!
val it : unit = ()

> agent.Post(Message3("abc"));;
val it : unit = ()

> agent.Post(Message2(100));;
message 2!
val it : unit = ()

> agent.CurrentQueueLength;;
val it : int = 1

```

---

When you send `Message3` to the message processor, the message is ignored. The last line, however, shows that the unprocessed `Message3` is still in the message queue, which you could examine using the backdoor property `UnsafeMessageQueueContents`.

## Example: Asynchronous Web Crawling

At the start of this chapter, we mentioned that the rise of the Web and other forms of networks is a major reason for the increasing importance of concurrent and asynchronous programming. Listing 11-13 shows an implementation of a Web crawler using asynchronous programming and mailbox-processing techniques.



*Listing 11-13. A scalable, controlled, asynchronous Web crawler*

```

open System.Collections.Generic
open System.Net
open System.IO
open System.Threading
open System.Text.RegularExpressions

let limit = 50
let linkPat = "href=\\s*\"[^\"]*(http://[^\"]*)\"\\s*"
let getLinks (txt:string) =
    [ for m in Regex.Matches(txt,linkPat) -> m.Groups.Item(1).Value ]

// A type that helps limit the number of active web requests
type RequestGate(n:int) =
    let semaphore = new Semaphore(initialCount=n,maximumCount=n)
    member x.AsyncAcquire(?timeout) =
        async { let! ok = Async.AwaitWaitHandle(semaphore,
            ?millisecondsTimeout=timeout)
            if ok then
                return
                { new System.IDisposable with
                    member x.Dispose() =
                        semaphore.Release() |> ignore }
            else
                return! failwith "couldn't acquire a semaphore" }

// Gate the number of active web requests
let webRequestGate = RequestGate(5)

// Fetch the URL, and post the results to the urlCollector.
let collectLinks (url:string) =
    async { // An Async web request with a global gate
        let! html =
            async { // Acquire an entry in the webRequestGate. Release
                // it when 'holder' goes out of scope
                use! holder = webRequestGate.AsyncAcquire()

                let req = WebRequest.Create(url,Timeout=5)

                // Wait for the WebResponse
                use! response = req.AsyncGetResponse()

                // Get the response stream
                use reader = new StreamReader(response.GetResponseStream())

                // Read the response stream (note: a synchronous read)
                return reader.ReadToEnd() }

            // Compute the links, synchronously
            let links = getLinks html

            // Report, synchronously
            do printfn "finished reading %s, got %d links" url (List.length links)

            // We're done
            return links }

/// 'urlCollector' is a single agent that receives URLs as messages. It creates new
/// asynchronous tasks that post messages back to this object.

```

```

let urlCollector =
  MailboxProcessor.Start(fun self ->

    // This is the main state of the urlCollector
    let rec waitForUrl (visited : Set<string>) =

      async { // Check the limit
        if visited.Count < limit then

          // Wait for a URL...
          let! url = self.Receive()
          if not (visited.Contains(url)) then
            // Start off a new task for the new url. Each collects
            // links and posts them back to the urlCollector.
            do! Async.StartChild
              (async { let! links = collectLinks url
                for link in links do
                  self.Post link }) |> Async.Ignore

          // Recurse into the waiting state
          return! waitForUrl(visited.Add(url)) }

    // This is the initial state.
    waitForUrl(Set.empty))

```

You can initiate a web crawl from a particular URL as follows:

---

```

> urlCollector.Post "http://news.google.com";;
finished reading http://news.google.com, got 191 links
finished reading http://news.google.com/?output=rss, got 0 links
finished reading http://www.ktvu.com/politics/13732578/detail.html, got 14 links
finished reading http://www.washingtonpost.com/wp-dyn/content/art..., got 218 links
finished reading http://www.newsobserver.com/politics/story/646..., got 56 links
finished reading http://www.foxnews.com/story/0,2933,290307,0..., got 22 links
...

```

---

The key techniques shown in Listing 11-13 are:

- The type `RequestGate` encapsulates the logic needed to ensure that you place a global limit on the number of active Web requests occurring at any point. This is instantiated to the particular instance `webRequestGate` with limit 5. This uses a `System.Threading.Semaphore` object to coordinate access to this shared resource. Semaphores are discussed in more detail in “Using Shared-Memory Concurrency.”
- The `RequestGate` type ensures that Web requests sitting in the request queue don’t block threads but rather wait asynchronously as callback items in the thread pool until a slot in the `webRequestGate` becomes available.
- The `collectLinks` function is a regular asynchronous computation. It first enters the `RequestGate` (that is, acquires one of the available entries in the `Semaphore`). After a response has been received, it reads off the HTML from the resulting reader, scrapes the HTML for links using regular expressions, and returns the generated set of links.
- The `urlCollector` is the only message-processing program. It’s written using a `MailboxProcessor`. In its main state, it waits for a fresh URL and spawns a new

asynchronous computation to call `collectLinks` once one is received. For each collected link, a new message is sent back to the `urlCollector`'s mailbox. Finally, you recurse to the waiting state, having added the fresh URL to the overall set of URLs you've traversed so far.

- The operator `<->` is used as shorthand for posting a message to an agent. This is a recommended abbreviation in F# asynchronous programming.
- The `AsyncAcquire` method of the `RequestGate` type uses a design pattern called a *holder*. The object returned by this method is an `IDisposable` object that represents the acquisition of a resource. This holder object is bound using `use`, and this ensures that the resource is released when the computation completes or when the computation ends with an exception.

Listing 11-13 shows that it's relatively easy to create sophisticated, scalable asynchronous programs using a mix of message passing and asynchronous I/O techniques. Modern Web crawlers have thousands of outstanding open connections, indicating the importance of using asynchronous techniques in modern scalable Web-based programming.

## Observables

As you learned earlier in this chapter, events are a central F# idiom to express configurable callback structures. F# also supports a more advanced mechanism for configurable callbacks that is more compositional than events. These are called *observables*, and in particular, they are characterized by the `System.IObservable` and `System.IObserver` types in the core libraries.

F# makes working with observables very easy, because all event objects also implement these interfaces and so can be used as observables. F# has only a limited library of combinators for working with observables in its core library, however. For example, here's how you can use observables to work with click events raised by a form:

---

```
> open System.Windows.Forms;;

> let form = new Form(Text = "Click Form", Visible = true, TopMost = true);;

val form : Form

> form.Click |> Observable.add (fun evArgs -> printfn "Clicked!");;

val it : unit = ()
```

---

When you run this code in F# Interactive, you see the expected printing each time the form is clicked. Likewise, you can filter and map using `Observable.filter` and `Observable.map` observables.

Programming with observables is powerful and compositional, and many further combinators are supported by the Rx programming library, available through the Rx library website on [www.codeplex.com](http://www.codeplex.com).

## Using Shared-Memory Concurrency

The final topics covered in this chapter are the various primitive mechanisms used for threads, shared-memory concurrency, and signaling. In many ways, these are the assembly language of concurrency.

This chapter has concentrated mostly on techniques that work well with immutable data structures. That isn't to say you should *always* use immutable data structures. It is, for example, perfectly valid to use mutable data structures as long as they're accessed from only one particular thread. Furthermore, private mutable data structures can often be safely passed through an asynchronous workflow, because at each point the mutable data structure is accessed by only one thread, even if different parts of the asynchronous workflow are executed by different threads. This doesn't apply to workflows that use operators, such as `Async.Parallel` and `Async.StartChild`, that start additional threads of computation.

This means we've largely avoided covering shared-memory primitives so far, because F# provides powerful declarative constructs, such as asynchronous workflows and message passing, that often subsume the need to resort to shared-memory concurrency. A working knowledge of thread primitives and shared-memory concurrency is still very useful, however, especially if you want to implement your own basic constructs or highly efficient concurrent algorithms on shared-memory hardware.

## Creating Threads Explicitly

This chapter has avoided showing how to work with threads directly, instead relying on abstractions, such as `BackgroundWorker` and the .NET thread pool. If you want to create threads directly, here is a short sample:

```
open System.Threading
let t = new Thread(ThreadStart(fun _ ->
    printfn "Thread %d: Hello" Thread.CurrentThread.ManagedThreadId));
t.Start();
printfn "Thread %d: Waiting!" Thread.CurrentThread.ManagedThreadId
t.Join();
printfn "Done!"
```

When run, this gives:

---

```
val t : Thread

Thread 1: Waiting!
Thread 10: Hello
Done!
```

---

■ **Caution:** Always avoid using `Thread.Suspend`, `Thread.Resume`, and `Thread.Abort`. These are guaranteed to put obscure concurrency bugs in your program. The MSDN Web site has a good description of why `Thread.Abort` may not even succeed. One of the only compelling uses for `Thread.Abort` is to implement Ctrl+C in an interactive development environment for a general-purpose language, such as F# Interactive.

---

## Shared Memory, Race Conditions, and the .NET Memory Model

Many multithreaded applications use mutable data structures shared among multiple threads. Without synchronization, these data structures will almost certainly become corrupt: threads may read data that have been only partially updated (because not all mutations are *atomic*), or two threads may write to the same data simultaneously (a *race condition*). Mutable data structures are usually protected by *locks*, although lock-free mutable data structures are also possible.

Shared-memory concurrency is a difficult and complicated topic, and a considerable amount of good material on .NET shared-memory concurrency is available on the Web. All this material applies to F# when you're programming with mutable data structures such as reference cells, arrays, and hash tables, and the data structures can be accessed from multiple threads simultaneously. F# mutable data structures map to .NET memory in fairly predictable ways; for example, mutable references become mutable fields in a .NET class, and mutable fields of word size can be assigned atomically.

On modern microprocessors, multiple threads can see views of memory that aren't consistent; that is, not all writes are propagated to all threads immediately. The guarantees given are called a *memory model* and are usually expressed in terms of the ordering dependencies among instructions that read/write memory locations. This is, of course, deeply troubling, because you have to think about a huge number of possible reorderings of your code, and it's one of the main reasons why shared mutable data structures are difficult to work with. You can find further details on the .NET memory model at [www.expert-fsharp.net/topics/MemoryModel](http://www.expert-fsharp.net/topics/MemoryModel).

## Using Locks to Avoid Race Conditions

Locks are the simplest way to enforce mutual exclusion between two threads attempting to read or write the same mutable memory location. Listing 11-14 shows an example of code with a race condition.

*Listing 11-14. Shared-memory code with a race condition*

```
type MutablePair<'T, 'U>(x : 'T, y : 'U) =
    let mutable currentX = x
    let mutable currentY = y
    member p.Value = (currentX, currentY)
    member p.Update(x, y) =
        // Race condition: This pair of updates is not atomic
        currentX <- x
        currentY <- y

let p = new MutablePair<_, _>(1, 2)
do Async.Start (async {do (while true do p.Update(10, 10))})
do Async.Start (async {do (while true do p.Update(20, 20))})
Here is the definition of the F# lock function:
open System.Threading
let lock (lockobj : obj) f =
    Monitor.Enter lockobj
    try
        f()
    finally
        Monitor.Exit lockobj
```

The pair of mutations in the Update method isn't atomic; that is, one thread may have written to currentX, another then writes to both currentX and currentY, and the final thread then writes to currentY, leaving the pair holding the value (10,20) or (20,10). Mutable data structures are inherently prone to this kind of problem if shared among multiple threads. Luckily, F# code tends to have fewer mutations than imperative languages, because functions normally take immutable values and return a calculated value. When you do use mutable data structures, they shouldn't be shared among threads, or you should design them carefully and document their properties with respect to multithreaded access.

Here is one way to use the F# lock function to ensure that updates to the data structure are atomic. Locks are also required on uses of the property p.Value:

```
do Async.Start (async { do (while true do lock p (fun () -> p.Update(10,10))) })
do Async.Start (async { do (while true do lock p (fun () -> p.Update(20,20))) })
```

---

■ **Caution:** If you use locks inside data structures, do so only in a simple way that uses them to enforce the concurrency properties you've documented. Don't lock just for the sake of it, and don't hold locks longer than necessary. In particular, beware of making indirect calls to externally supplied function values, interfaces, or abstract members while a lock is held. The code providing the implementation may not be expecting to be called when a lock is held, and it may attempt to acquire further locks in an inconsistent fashion.

---

## Using ReaderWriterLock

It's common for mutable data structures to be read more than they're written. Indeed, mutation often is used only to initialize a mutable data structure. In this case, you can use a .NET `ReaderWriterLock` to protect access to a resource. For example, consider the functions:

```
open System.Threading

let readLock (rwlock : ReaderWriterLock) f =
    rwlock.AcquireReaderLock(Timeout.Infinite)
    try
        f()
    finally
        rwlock.ReleaseReaderLock()

let writeLock (rwlock : ReaderWriterLock) f =
    rwlock.AcquireWriterLock(Timeout.Infinite)
    try
        f()
        Thread.MemoryBarrier()
    finally
        rwlock.ReleaseWriterLock()
```

Listing 11-15 shows how to use these functions to protect the `MutablePair` class.

### *Listing 11-15. Shared-memory code with a race condition*

```
type MutablePair<'T, 'U>(x : 'T, y : 'U) =
    let mutable currentX = x
    let mutable currentY = y
    let rwlock = new ReaderWriterLock()
    member p.Value =
        readLock rwlock (fun () ->
            (currentX, currentY))
    member p.Update(x, y) =
        writelock rwlock (fun () ->
            currentX <- x
            currentY <- y)
```

## Some Other Concurrency Primitives

Table 11-10 shows some other shared-memory concurrency primitives available in the .NET Framework.

**Table 11-10.** .NET shared-memory concurrency primitives

Type	Description
<code>System.Threading.WaitHandle</code>	A synchronization object for signaling the control of threads.
<code>System.Threading.AutoResetEvent</code>	A two-state (on/off) <code>WaitHandle</code> that resets itself to “off” automatically after the signal is read. Similar to a two-state traffic light.
<code>System.Threading.ManualResetEvent</code>	A two-state (on/off) <code>WaitHandle</code> that requires a call to <code>ManualResetEvent.Reset()</code> to set it “off.”
<code>System.Threading.Mutex</code>	A lock-like object that can be shared among operating system processes.
<code>System.Threading.Semaphore</code>	Used to limit the number of threads simultaneously accessing a resource. Use a mutex or lock if at most one thread can access a resource at a time, however.
<code>System.Threading.Interlocked</code>	Atomic operations on memory locations. Especially useful for atomic operations on F# reference cells.

## Summary

This chapter covered concurrent, reactive, and asynchronous programming, topics of growing importance in modern programming because of the widespread adoption of multicore microprocessors, network-aware applications, and asynchronous I/O channels. It discussed, in depth, background processing and a powerful F# construct called *asynchronous workflows*. Finally, the chapter covered applications of asynchronous workflows to message-processing agents and Web crawling, and it examined some of the shared-memory primitives for concurrent programming on the .NET platform. The next chapter returns to look at further applied topics in symbolic programming.

## CHAPTER 12



# Symbolic Programming with Structured Data

Symbols are everywhere. Numbers are symbols that stand for quantities, and you can add, multiply, or take square roots of numbers that are so small or large that it's hard to imagine the quantity they represent. You can solve equations, multiply polynomials, approximate functions using series, and differentiate or integrate numerically or symbolically—these are just a few everyday examples of using symbols in mathematics.

It would be a mistake to think symbols are useful only in mathematics and related fields. General problem-solving can't do without symbols; they provide the ability to abstract away details to make the larger picture clearer and help you understand relationships that may not appear obvious otherwise. Symbols always stand for something and have an attached meaning; they're created to bind this additional content to an existing object. This gives you an extraordinary tool to solve problems, describe behavior, make strategic decisions, create new words, and write poetry—the list could go on forever.

F# is well suited for symbolic computations. This chapter covers in depth two symbolic manipulation problems. First, it presents an implementation of a symbolic differentiation application, including expression rendering using techniques based on Windows Forms programming. The second example shows how you can use symbolic programming to model hardware circuits and presents the core of a symbolic hardware-verification engine based on binary decision diagrams. We could have chosen other examples of symbolic programming, but we found these two particularly enjoyable to code in F#.

Chapter 9 already covered many of the foundational techniques for symbolic programming. One technique that is particularly important in this chapter is the use of discriminated unions to capture the shape of the abstract syntax trees for symbolic languages. Using functions as first-class values and applying recursive problem decomposition also leads to a natural and clean approach to computations on symbolic entities. These and other features of F# combine to make symbolic programming concise and painless, allowing you to focus on the really interesting parts of your application domain.

## Verifying Circuits with Propositional Logic

The next example turns to a traditional application area for functional programming: describing digital hardware circuits and symbolically verifying their properties. We assume a passing familiarity with hardware design, but if you haven't looked inside a microprocessor chip for some time, a brief recap is included in the “About Hardware Design” sidebar.



In this example, you model circuits by *propositional logic*, a simple and familiar symbolic language made up of constructs such as AND, OR, NOT, and TRUE/FALSE values. You then implement an analysis that converts propositional logic formulae into a canonical form called *binary decision diagrams* (BDDs). Converting to a canonical form allows you to check conditions and properties associated with the digital circuits.

---

## ABOUT HARDWARE DESIGN

---

Digital hardware circuits such as microprocessors almost universally manipulate *bits*—that is, signals that are either low or high, represented by 0/1 or false/true values, respectively. The building blocks of interesting hardware circuits are primitives such as *gates* and *registers*. Gates are logical components that relate their inputs to their outputs; for example, an AND gate takes two input signals, and if both are high, it gives a high signal on its output. Registers are stateful components associated with a clock. This chapter doesn't consider registers and stateful circuits, although they can be tackled using techniques similar to those described here.

Hardware design is largely about building interesting behavior out of these primitives. For example, you can build arithmetic circuits that compute the sum or product of integers by using logical gates alone. These combinatorial circuits can be massive, and a key concern is to both verify their correctness and minimize the overall electrical delay through the circuit.

---

■ **Note** The examples in this section are inspired by the tutorials for the HOL88 system, a symbolic theorem prover implemented using an F#-like language that has been used for many purposes, including hardware verification. The carry/select adder and the BDD implementation follow those given by John Harrison in his HOL Light version of the same system. You can find out more about these and other systems, as well as delve into theorem proving, in *Handbook of Practical Logic and Automated Reasoning* by John Harrison (Cambridge University Press, 2009).

---

## Representing Propositional Logic

You begin by using language-oriented programming techniques to implement a little logic of Boolean expressions, of the kind that might be used to describe part of a hardware circuit or a constraint. Let's assume these have forms like the following:

```
P1 AND P2
P1 OR P2
P1 IMPLIES P2
NOT(P1)
v                -- variable, ranging over true/false
TRUE
FALSE
Exists v. P[v]   -- v ranges over true/false, P may use v
Forall v. P[v]   -- v ranges over true/false, P may use v
```

This is known as *quantified Boolean formulae* (QBF) and is an expressive way of modeling many interesting problems and artifacts that work over finite data domains. Listing 12-1 shows how you model this language in F#.

*Listing 12-1. A Minimalistic Representation of Propositional Logic*

```

type Var = string

type Prop =
  | And of Prop * Prop
  | Var of Var
  | Not of Prop
  | Exists of Var * Prop
  | False

let True          = Not False
let Or(p, q)      = Not(And(Not(p), Not(q)))
let Iff(p, q)     = Or(And(p, q), And(Not(p), Not(q)))
let Implies(p, q) = Or(Not(p), q)
let Forall(v, p)  = Not(Exists(v, Not(p)))

let (&&&) p q = And(p, q)
let (|||) p q = Or(p, q)
let (~~~) p   = Not p
let (<=>) p q = Iff(p, q)
let (==) p q  = (p <=> q)
let (==>) p q = Implies(p, q)
let (^^^)^ p q = Not (p <=> q)

let var (nm: Var) = Var nm

let fresh =
  let count = ref 0
  fun nm -> incr count; (sprintf "%s%d" nm !count : Var)

```

Listing 12-1 uses a *minimalistic* encoding of propositional logic terms, where `True`, `Or`, `Iff`, `Implies`, and `Forall` are *derived* constructs, defined using their standard classical definitions in terms of the primitives `Var`, `And`, `Not`, `Exists`, and `False`. This is adequate for your purposes because you aren't so interested in preserving the original structure of formulae; if you do need to display a symbolic propositional formula, you're happy to display a form different than the original input.

Variables in formulae of type `Prop` are *primitive propositions*. A primitive proposition is often used to model some real-world possibility. For example, “it is raining,” “it is cold,” and “it is snowing” can be represented by `Var("raining")`, `Var("cold")`, and `Var("snowing")`. A `Prop` formula may be a *tautology*—that is, something that is always true regardless of the interpretation of these primitives. A formula is *satisfiable* if there is at least one interpretation for which it's true. A formula can also be an *axiom*; for example, “if it's snowing, then it's cold” can be represented as the assumption `Implies(Var("snowing"), Var("cold"))`. In this example, variables are used to represent a wire in a digital circuit that may be low or high.

When you're dealing directly with the abstract syntax for `Prop`, it can be convenient to define infix operators to help you build abstract syntax values. Listing 12-1 shows the definition of seven operators (`&&&`, `|||`, `~`, `<=>`, `==`, `==>`, and `^^^`) that look a little like the notation you expect for propositional logic. You also define the function `var` for building primitive propositions and `fresh` for generating fresh variables. The types of these functions are as follows:

---

```

val var : nm:Var -> Prop
val fresh : (string -> Var)

```

---

■ **NOTE** The operators in Listing 12-1 aren't overloaded and indeed outscope the default overloaded bitwise operations on integers discussed in Chapter 3. However, that doesn't matter for the purposes of this chapter. If necessary, you can use alternative operator names.

## Evaluating Propositional Logic Naively

Before tackling the problem of representing hardware using propositional logic, let's look at some naive approaches for working with propositional logic formulae. Listing 12-2 shows routines that evaluate formulae given an assignment of variables and that generate the rows of a **truth table** for a *Prop* formula.

*Listing 12-2. Evaluating Propositional Logic Formulae*

```
let rec eval (env: Map<Var, bool>) inp =
  match inp with
  | Exists(v, p) -> eval (env.Add(v, false)) p || eval (env.Add(v, true)) p
  | And(p1, p2)  -> eval env p1 && eval env p2
  | Var v       -> if env.ContainsKey(v) then env.[v]
                  else failwithf "env didn't contain a value for %A" v
  | Not p       -> not (eval env p)
  | False      -> false

let rec support f =
  match f with
  | And(x, y)    -> Set.union (support x) (support y)
  | Exists(v, p) -> (support p).Remove(v)
  | Var p        -> Set.singleton p
  | Not x        -> support x
  | False       -> Set.empty

let rec cases supp =
  seq {
    match supp with
    | [] -> yield Map.empty
    | v :: rest ->
        yield! rest |> cases |> Seq.map (Map.add v false)
        yield! rest |> cases |> Seq.map (Map.add v true)
  }

let truthTable x =
  x |> support |> Set.toList |> cases
  |> Seq.map (fun env -> env, eval env x)

let satisfiable x =
  x |> truthTable |> Seq.exists (fun (env, res) -> res)

let tautology x =
  x |> truthTable |> Seq.forall (fun (env, res) -> res)

let tautologyWithCounterExample x =
  x |> truthTable |> Seq.tryFind (fun (env, res) -> not res)
  |> Option.map fst

let printCounterExample = function
  | None -> printfn "tautology verified OK"
  | Some env -> printfn "tautology failed on %A" (Seq.toList env)
```

The types of these functions are as follows:

---

```

val eval : env:Map<Var,bool> -> inp:Prop -> bool
val support : f:Prop -> Set<Var>
val cases : supp:'a list -> seq<Map<'a,bool>> when 'a : comparison
val truthTable : x:Prop -> seq<Map<Var,bool> * bool>
val satisfiable : x:Prop -> bool
val tautology : x:Prop -> bool
val tautologyWithCounterExample : x:Prop -> Map<Var,bool> option
val printCounterExample : _arg1:#seq<'b> option -> unit

```

---

The function `eval` computes the value of a formula given assignments for each of the variables that occurs in the formula. `support` computes the set of variables that occurs in the formula. You can now use these functions to examine truth tables for some simple formulae, although first you may want to define the following functions to display truth tables neatly in F# Interactive:

```

let stringOfBit b = if b then "T" else "F"

let stringOfEnv env =
    Map.fold (fun acc k v -> sprintf "%s=%s;" k (stringOfBit v) + acc) "" env

let stringOfLine (env, res) =
    sprintf "%20s %s" (stringOfEnv env) (stringOfBit res)

let stringOfTruthTable tt =
    "\n" + (tt |> Seq.toList |> List.map stringOfLine |> String.concat "\n")

```

Here are the truth tables for  $x$ ,  $x$  AND  $y$ , and  $x$  OR NOT( $x$ ):

---

```

> fsi.AddPrinter(fun tt -> tt |> Seq.truncate 20 |> stringOfTruthTable);;

> truthTable (var "x");;
val it : seq<Map<Var,bool> * bool> =

        x=F; F
        x=T; T
> truthTable (var "x" &&& var "y");;
val it : seq<Map<Var,bool> * bool> =

        y=F;x=F; F
        y=T;x=F; F
        y=F;x=T; F
        y=T;x=T; T
> truthTable (var "x" ||| ~~~(var "x"));;
val it : seq<Map<Var,bool> * bool> =

        x=F; T

```

---

From this, you can see that  $x$  OR NOT( $x$ ) is a tautology, because it always evaluates to TRUE regardless of the value of the variable  $x$ .

## From Circuits to Propositional Logic

Figure 12-1 shows a diagrammatic representation of three hardware circuits: a *half adder*, a *full adder*, and a *2-bit carry ripple adder*. The first of these has two input wires,  $x$  and  $y$ , and sets the *sum* wire high if exactly one of these is high. If both  $x$  and  $y$  are high, then the sum is low, and the carry wire is high instead. Thus, the circuit computes the 2-bit sum of the inputs. Likewise, a full adder computes the sum of three Boolean inputs, which, because it's at most three, can still be represented by 2 bits. A 2-bit carry ripple adder is formed by composing a half adder and a full adder together, wiring the carry from the first adder to one of the inputs of the second adder. The overall circuit has four inputs and three outputs.

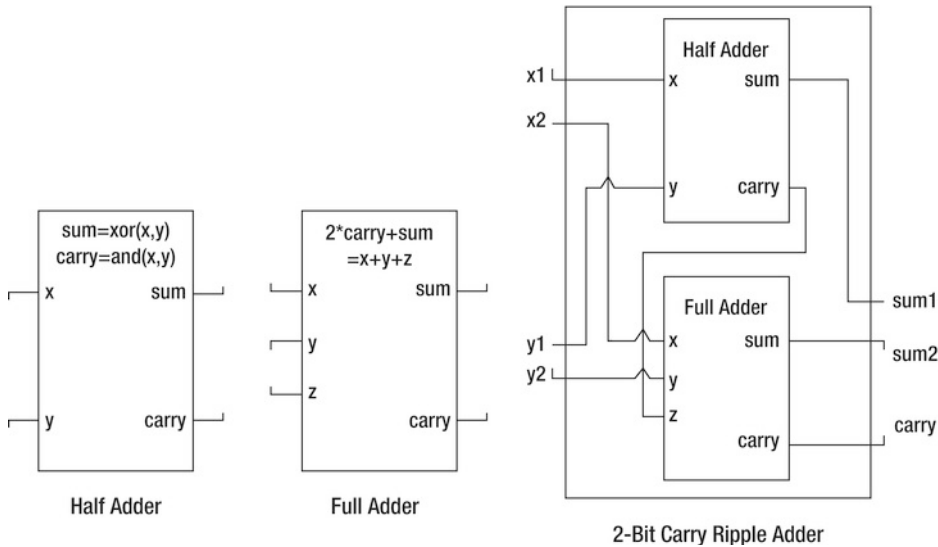

Figure 12-1. Three simple hardware circuits

The following code models these circuit components. This uses *relational modeling*, where each circuit is modeled not as a function but as a propositional logic predicate that relates its input wires to its output wires:

```
let sumBit x y = (x ^^ y)
let carryBit x y = (x && y)
let halfAdder x y sum carry =
  (sum === sumBit x y) &&&
  (carry === carryBit x y)

let fullAdder x y z sum carry =
  let xy = (sumBit x y)
  (sum === sumBit xy z) &&&
  (carry === (carryBit x y ||| carryBit xy z))

let twoBitAdder (x1, x2) (y1, y2) (sum1, sum2) carryInner carry =
  halfAdder x1 y1 sum1 carryInner &&&
  fullAdder x2 y2 carryInner sum2 carry
```

Note the close relation between the diagram for the 2-bit adder and its representation as code. You can read the implementation as a specification of the diagram, and vice versa. But the types of these functions are a little less informative:

---

```

val sumBit : x:Prop -> y:Prop -> Prop
val carryBit : x:Prop -> y:Prop -> Prop
val halfAdder : x:Prop -> y:Prop -> sum:Prop -> carry:Prop -> Prop
val fullAdder : x:Prop -> y:Prop -> z:Prop -> sum:Prop -> carry:Prop -> Prop
val twoBitAdder :
  x1:Prop * x2:Prop ->
  y1:Prop * y2:Prop ->
  sum1:Prop * sum2:Prop -> carryInner:Prop -> carry:Prop -> Prop

```

---

In practice, circuits are defined largely with respect to vectors of wires, not just individual wires. You can model these using arrays of propositions; and because it's now clear that you're modeling bits via propositions, you make an appropriate type abbreviation for them as well:

```

type bit = Prop
type bitvec = bit[]

let Lo : bit = False
let Hi : bit = True
let vec n nm : bitvec = Array.init n (fun i -> var (sprintf "%s%d" nm i))
let bitEq (b1: bit) (b2: bit) = (b1 <=> b2)
let AndL l = Seq.reduce (fun x y -> And(x, y)) l
let vecEq (v1: bitvec) (v2: bitvec) = AndL (Array.map2 bitEq v1 v2)

```

These functions have types as follows:

---

```

type bit = Prop
type bitvec = bit []
val Lo : bit = False
val Hi : bit = Not False
val vec : n:int -> nm:string -> bitvec
val bitEq : b1:bit -> b2:bit -> Prop
val AndL : l:seq<Prop> -> Prop
val vecEq : v1:bitvec -> v2:bitvec -> Prop

```

---

You can now proceed to define larger circuits. For example:

```

let fourBitAdder (x: bitvec) (y: bitvec) (sum: bitvec) (carry: bitvec) =
  halfAdder x.[0] y.[0] sum.[0] carry.[0] &&&
  fullAdder x.[1] y.[1] carry.[0] sum.[1] carry.[1] &&&
  fullAdder x.[2] y.[2] carry.[1] sum.[2] carry.[2] &&&
  fullAdder x.[3] y.[3] carry.[2] sum.[3] carry.[3]

```

Or, more generally, you can chain an arbitrary series of adders to form an  $N$ -bit adder. First you define an abbreviation for the `AndL` function to represent the composition of multiple circuit blocks:

```

let Blocks l = AndL l

```

And here is the definition of an  $N$ -bit adder with a halfAdder at one end:

```
let nBitCarryRippleAdder (n: int) (x: bitvec) (y: bitvec)
    (sum: bitvec) (carry: bitvec) =
  Blocks [ for i in 0 .. n-1 ->
    if i = 0
    then halfAdder x.[i] y.[i] sum.[i] carry.[i]
    else fullAdder x.[i] y.[i] carry.[i-1] sum.[i] carry.[i] ]
```

Using a similar approach, you get the following satisfying specification of a symmetric  $N$ -bit adder that accepts a carry as input and also gives a carry as output:

```
let rippleAdder (n: int) (x: bitvec) (y: bitvec)
    (sum: bitvec) (carry: bitvec) =
  Blocks [ for i in 0 .. n-1 ->
    fullAdder x.[i] y.[i] carry.[i] sum.[i] carry.[i+1] ]
```

Let's now look at the propositional formula for a halfAdder with variable inputs and outputs:

---

```
> halfAdder (var "x") (var "y") (var "sum") (var "carry");;

val it : Prop =
  And
    (Not
      (And
        (Not
          (And
            (Var "sum",
              Not
                (Not
                  (And
                    (Not (And (Var "x", Var "y")),
                      Not (And (Not (Var "x"), Not (Var "y")))))))),
          Not
            (And
              (Not (Var "sum"),
                Not
                  (Not
                    (Not
                      (And
                        (Not (And (Var "x", Var "y")),
                          Not (And (Not (Var "x"), Not (Var "y"))))))))))),
          Not
            (And
              (Not (And (Var "carry", And (Var "x", Var "y"))),
                Not (And (Not (Var "carry"), Not (And (Var "x", Var "y"))))))))
```

---

Clearly, you don't want to be doing too much of that! You see better ways of inspecting circuits and the symbolic values of bit vectors in the section "Representing Propositional Formulae Efficiently Using BDDs."

In passing, note that the twoBitAdder uses an internal wire. You can model this using an existential formula:

```
let twoBitAdderWithHiding (x1, x2) (y1, y2) (sum1, sum2) carry =
  let carryInnerVar = fresh "carry"
  let carryInner = var(carryInnerVar)
  Exists(carryInnerVar, halfAdder x1 y1 sum1 carryInner &&&
    fullAdder x2 y2 carryInner sum2 carry)
```

However, this brings up issues beyond the scope of this chapter. Instead, you take an approach to modeling where there are no boundaries to the circuits and where all internal wires are exposed.

## Checking Simple Properties of Circuits

Now that you've modeled the initial hardware circuits, you can check simple properties of these circuits. For example, you can check that if you give a `fullAdder` all low (that is, false) inputs, then the output wires may be low as well, and, conversely, that you have a contradiction if one of the output wires is high:

---

```
> tautology (fullAdder Lo Lo Lo Lo Lo);;
val it : bool = true

> satisfiable (fullAdder Lo Lo Lo Hi Lo);;
val it : bool = false
```

---

It's of course much better to check these results *symbolically* by giving symbolic inputs. For example, you can check that if the same value is given to the two inputs of a `halfAdder`, then the sum output is low and the carry output is the same as the input:

---

```
> tautology (halfAdder (var "x") (var "x") Lo (var "x"));;
val it : bool = true
```

---

Likewise, you can check that a 2-bit adder is commutative—in other words, that it doesn't matter if you swap the  $x$  and  $y$  inputs:

---

```
> tautology
  (nBitCarryRippleAdder 2 (vec 2 "x") (vec 2 "y") (vec 2 "sum") (vec 3 "carry")
  === nBitCarryRippleAdder 2 (vec 2 "y") (vec 2 "x") (vec 2 "sum") (vec 3 "carry"));;
val it : bool = true
```

---

However, if you repeat the same for sizes of 5 or bigger, things start to slow down, and the naive implementation of checking propositional logic tautology based on truth tables begins to break down. Hence, you have to turn to more efficient techniques to process propositional formulae.

## Representing Propositional Formulae Efficiently Using BDDs

In practice, propositional formulae to describe hardware can be enormous, involving hundreds of thousands of nodes. As a result, hardware companies have an interest in smart algorithms to process these formulae and check them for correctness. The circuits in the computers you use from day to day have almost certainly been verified using advanced propositional logic techniques, often using a functional language as the means to drive and control the analysis of the circuits.



A major advance in the application of symbolic techniques to hardware design occurred in the late 1980s with the discovery of *binary decision diagrams*, a representation for propositional logic formulae that is compact for many common circuit designs. BDDs represent a propositional formula via the use of if ... then ... else conditionals alone, which you write as (variable => true-branch | false-branch). Special nodes are used for true and false at the leaves: you write these as T and F. Every BDD is constructed with respect to a global variable ordering, so  $x$  AND NOT  $y$  can be represented as  $(x \Rightarrow (y \Rightarrow F \mid T) \mid F)$  if  $x$  comes before  $y$  in this ordering and as  $(y \Rightarrow F \mid (x \Rightarrow T \mid F))$  if  $y$  comes before  $x$ . The variable ordering can be critical for performance of the representation.

BDDs are efficient because they use some of the language representation techniques you saw in Chapter 9. In particular, they work by *uniquely memoizing* all BDD nodes that are identical, which works by representing a BDD as an integer index into a lookup table that stores the real information about the node. Furthermore, negative indexes are used to represent the negation of a particular BDD node without creating a separate entry for the negated node. Listing 12-3 shows an implementation of BDDs. Fully polished BDD packages are often implemented in C. It's easy to access those packages from F# using the techniques described in Chapter 19. Here, you have a clear and simple implementation entirely in F# code.

*Listing 12-3. Implementing Binary Decision Diagrams*

```
open System.Collections.Generic

let memoize f =
    let tab = new Dictionary<_, _>()
    fun x ->
        if tab.ContainsKey(x) then tab.[x]
        else let res = f x in tab.[x] <- res; res

type BddIndex = int
type Bdd = Bdd of BddIndex
type BddNode = Node of Var * BddIndex * BddIndex
type BddBuilder(order: Var -> Var -> int) =

    // The core data structures that preserve uniqueness
    let nodeToIndex = new Dictionary<BddNode, BddIndex>()
    let indexToNode = new Dictionary<BddIndex, BddNode>()

    // Keep track of the next index
    let mutable nextIdx = 2
    let trueIdx = 1
    let falseIdx = -1
    let trueNode = Node("", trueIdx, trueIdx)
    let falseNode = Node("", falseIdx, falseIdx)

    // Map indexes to nodes. Negative indexes go to their negation.
    // The special indexes -1 and 1 go to special true/false nodes.
    let idxToNode(idx) =
        if idx = trueIdx then trueNode
        elif idx = falseIdx then falseNode
        elif idx > 0 then indexToNode.[idx]
        else
            let (Node(v, l, r)) = indexToNode.[-idx]
            Node(v, -l, -r)
```

```

// Map nodes to indexes. Add an entry to the table if needed.
let nodeToUniqueIdx(node) =
  if nodeToIndex.ContainsKey(node) then nodeToIndex.[node]
  else
    let idx = nextIdx
    nodeToIndex.[node] <- idx
    indexToNode.[idx] <- node
    nextIdx <- nextIdx + 1
    idx

// Get the canonical index for a node. Preserve the invariant that the
// left-hand node of a conditional is always a positive node
let mkNode(v: Var, l: BddIndex, r: BddIndex) =
  if l = r then l
  elif l >= 0 then nodeToUniqueIdx(Node(v, l, r) )
  else -nodeToUniqueIdx(Node(v, -l, -r))

// Construct the BDD for a conjunction "m1 AND m2"
let rec mkAnd(m1, m2) =
  if m1 = falseIdx || m2 = falseIdx then falseIdx
  elif m1 = trueIdx then m2
  elif m2 = trueIdx then m1
  else
    let (Node(x, l1, r1)) = idxToNode(m1)
    let (Node(y, l2, r2)) = idxToNode(m2)
    let v, (la, lb), (ra, rb) =
      match order x y with
      | c when c = 0 -> x, (l1, l2), (r1, r2)
      | c when c < 0 -> x, (l1, m2), (r1, m2)
      | c -> y, (m1, l2), (m1, r2)
    mkNode(v, mkAnd(la, lb), mkAnd(ra, rb))

// Memoize this function
let mkAnd = memoize mkAnd

// Publish the construction functions that make BDDs from existing BDDs
member g.False = Bdd falseIdx
member g.And(Bdd m1, Bdd m2) = Bdd(mkAnd(m1, m2))
member g.Not(Bdd m) = Bdd(-m)
member g.Var(nm) = Bdd(mkNode(nm, trueIdx, falseIdx))
member g.NodeCount = nextIdx
The types of these functions are as follows:

```

---

```

val memoize : f:( 'a -> 'b ) -> ( 'a -> 'b ) when 'a : equality
type BddIndex = int
type Bdd = | Bdd of BddIndex
type BddNode = | Node of Var * BddIndex * BddIndex
type BddBuilder =
  class
    new : order:(Var -> Var -> int) -> BddBuilder

```

```

member And : Bdd * Bdd -> Bdd
member Not : Bdd -> Bdd
member Var : nm:Var -> Bdd
member False : Bdd
member NodeCount : int
end

```

---

In addition to the functions that ensure that nodes are unique, the only substantial function in the implementation is `mkAnd`. It relies on the following logical rules for constructing BDD nodes formed by taking the conjunction of existing nodes. Note how the second rule is used to interleave variables:

- $(x \Rightarrow P \mid Q) \text{ AND } (x \Rightarrow R \mid S)$  is identical to  $(x \Rightarrow P \text{ AND } R \mid Q \text{ AND } S)$ .
- $(x \Rightarrow P \mid Q) \text{ AND } (y \Rightarrow R \mid S)$  is identical to  $(x \Rightarrow P \text{ AND } T \mid Q \text{ AND } T)$  where  $T$  is simply  $(y \Rightarrow R \mid S)$ .

One final important optimization in the implementation is to memoize the application of the `mkAnd` operation.

Given the previous implementation of BDDs, you can now add the members `ToString` to convert BDDs to strings, `Build` to convert a `Prop` representation of a formula into a BDD, and `Equiv` to check for equivalence between two BDDs:

```

type BddBuilder(order: Var -> Var -> int) =
  ...
  member g.ToString(Bdd idx) =
    let rec fmt dep idx =
      if dep > 3 then "... " else
        let (Node(p, l, r)) = idxToNode(idx)
        if p = "" then if l = trueIdx then "T" else "F"
        else sprintf "(%s => %s | %s)" p (fmt (dep+1) l) (fmt (dep+1) r)
    in fmt 1 idx

  member g.Build(f) =
    match f with
    | And(x, y) -> g.And(g.Build x, g.Build y)
    | Var(p) -> g.Var(p)
    | Not(x) -> g.Not(g.Build x)
    | False -> g.False
    | Exists(v, p) -> failwith "Exists node"

  member g.Equiv(p1, p2) = g.Build(p1) = g.Build(p2)

```

You can now install a pretty-printer and inspect the BDDs for some simple formulae:

---

```

> let bddBuilder = BddBuilder(compare);;
val bddBuilder: BddBuilder

> fsi.AddPrinter(fun bdd -> bddBuilder.ToString(bdd));;
val it: unit = ()

> bddBuilder.Build(var "x");;
val it : Bdd = (x => T | F)

```

```

> bddBuilder.Build(var "x" &&& var "x");;
val it : Bdd = (x => T | F)

> bddBuilder.Build(var "x") = bddBuilder.Build(var "x" &&& var "x");;
val it : bool = true

> (var "x") = (var "x" &&& var "x");;
val it : bool = false

> bddBuilder.Build(var "x" &&& var "y");;
val it : Bdd = (x => (y => T | F) | F)

> bddBuilder.Equiv(var "x", var "x" &&& var "x");;
val it : bool = true

```

---

Note that the BDD representations of  $x$  and  $x$  AND  $x$  are identical, whereas the Prop representations aren't. The Prop representation is an *abstract syntax* representation, whereas the BDD representation is more of a *semantic* or *computational* representation. The BDD representation incorporates all the logic necessary to prove propositional formula equivalent; in other words, this logic is built into the representation.

## Circuit Verification with BDDs

You can now use BDDs to perform circuit verification. For example, the following verifies that you can swap the  $x$  and  $y$  inputs to an 8-bit adder:

```

> bddBuilder.Equiv(
  nBitCarryRippleAdder 8 (vec 8 "x") (vec 8 "y") (vec 8 "sum") (vec 9 "carry"),
  nBitCarryRippleAdder 8 (vec 8 "y") (vec 8 "x") (vec 8 "sum") (vec 9 "carry"));;
val it : bool = true

```

---

Thirty-three variables are involved in this circuit. A naive exploration of this space would involve searching a truth table of more than eight billion entries. The BDD implementation takes moments on any modern computer. Efficient symbolic representations pay off!

A more substantial verification problem involves checking the equivalence of circuits that have substantial structural differences. To explore this, let's take a different implementation of addition called a *carry select adder*. This avoids a major problem with ripple adders caused by the fact that the carry signal must propagate along the entire length of the chain of internal adders, causing longer delays in the electrical signals and thus reducing the clock rates of a circuit or possibly increasing power consumption. A carry select adder gets around this through a common hardware trick of speculative execution. It divides the inputs into blocks and adds each block twice: once assuming the carry is low and once assuming it's high. The result is then selected *after* the circuit, when the carry for the block has been computed. Listing 12-4 shows the specification of the essence of the hardware layout of a carry select adder using the techniques developed so far. The specification uses the slicing syntax for arrays described in Chapter 4.

*Listing 12-4. A Carry Select Adder Modeled Using Propositional Logic*

```

let mux a b c = ((~~~a ==> b) &&& (a ==> c))

let carrySelectAdder
  totalSize maxBlockSize
  (x: bitvec) (y: bitvec)
  (sumLo: bitvec) (sumHi: bitvec)
  (carryLo: bitvec) (carryHi: bitvec)
  (sum: bitvec) (carry: bitvec) =
  Blocks
  [ for i in 0..maxBlockSize..totalSize-1 ->
    let sz = min (totalSize-i) maxBlockSize
    let j = i+sz-1
    let carryLo = Array.append [| False |] carryLo.[i+1..j+1]
    let adderLo = rippleAdder sz x.[i..j] y.[i..j] sumLo.[i..j] carryLo
    let carryHi = Array.append [| True |] carryHi.[i+1..j+1]
    let adderHi = rippleAdder sz x.[i..j] y.[i..j] sumHi.[i..j] carryHi
    let carrySelect = (carry.[j+1] ==> mux carry.[i] carryLo.[sz] carryHi.[sz])
    let sumSelect =
      Blocks
      [ for k in i..j ->
        sum.[k] ==> mux carry.[i] sumLo.[k] sumHi.[k] ]
    adderLo &&& adderHi &&& carrySelect &&& sumSelect ]

```

You can now check that a `carrySelectAdder` is equivalent to a `rippleAdder`. Here's the overall verification condition:

```

let checkAdders n k =
  let x = vec n "x"
  let y = vec n "y"
  let sumA = vec n "sumA"
  let sumB = vec n "sumB"
  let sumLo = vec n "sumLo"
  let sumHi = vec n "sumHi"
  let carryA = vec (n+1) "carryA"
  let carryB = vec (n+1) "carryB"
  let carryLo = vec (n+1) "carryLo"
  let carryHi = vec (n+1) "carryHi"
  let adder1 = carrySelectAdder n k x y sumLo sumHi carryLo carryHi sumA carryA
  let adder2 = rippleAdder n x y sumB carryB
  (adder1 &&& adder2 &&& (carryA.[0] ==> carryB.[0]) ==>
    (vecEq sumA sumB &&& bitEq carryA.[n] carryB.[n]))

```

Ignoring the construction of the inputs, the verification condition specifies the following:

- Assume you have the two adder circuits, with the same inputs.
- Assume the input carry bits are the same.
- Then, the output sum vectors are identical, and the final output carry bits are identical.

Here is the verification condition being checked interactively, for 5-bit inputs, in chunks of 2 for the `carrySelectAdder`:

---

```
> bddBuilder.Equiv(checkAdders 5 2, True);;  
val it : bool = true
```

---

In practice, BDDs require a good variable ordering, and the default alphabetic ordering is unlikely to be the best. Here is a larger verification using a more random ordering induced by first comparing on the hash codes of the names of the variables:

```
let approxCompareOn f x y =  
    let c = compare (f x) (f y)  
    if c <> 0 then c else compare x y  
let bddBuilder2 = BddBuilder(approxCompareOn hash)
```

---

```
> bddBuilder2.Equiv(checkAdders 7 2, True);;  
val it : bool = true
```

---

Seventy-four Boolean variables are involved in this last verification problem. You would have to generate up to  $2^{74}$  test cases to explore this systematically via testing; that's 22 thousand billion billion test cases. By using symbolic techniques, you've explored this entire space in a matter of seconds and in only a few hundred lines of code.

---

■ **Note** Hardware and software verification are highly active areas of research and one of the most important applications of symbolic programming techniques in the industrial arena. The verifications performed here aim to give you a taste of how symbolic techniques can provide nontrivial results about circuits in a matter of seconds. We've omitted some simple techniques that can make these verifications scale to very large circuits; for example, we expand equivalence nodes in propositional formulae. Preserving them can lead to smaller symbolic descriptions and more efficient processing with BDDs.

---

## Symbolic Differentiation and Expression Rendering

You've probably come across the need to perform symbolic differentiation one way or another; and unless you had access to a full-fledged mathematics application such as Maple, Matlab or Mathematica, you had to resort to working out the math yourself on paper. This no longer has to be the case, because you can develop your own symbolic differentiation tool in almost no time and with surprising brevity and clarity. Figure 12-2 shows the symbolic differentiation application that you will implement in this chapter.

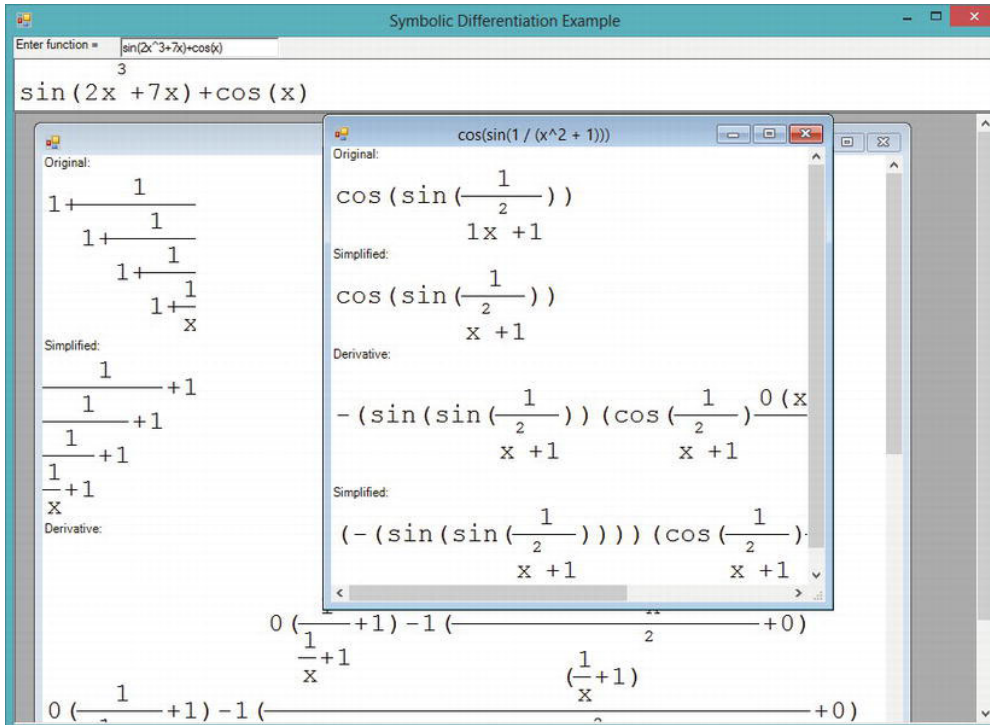

Figure 12-2. The visual symbolic differentiation application

## Modeling Simple Algebraic Expressions

Let's take it easy at first and assume you're dealing with simple algebraic expressions that can consist only of numbers, a single variable (it doesn't matter what it is, but let's assume it's  $x$ ), sums, and products. Listing 12-5 shows the implementation of symbolic differentiation over this simple expression type.

Listing 12-5. Symbolic Differentiation Over a Simple Expression Type

open System

type Expr =

```
| Var
| Num of int
| Sum of Expr * Expr
| Prod of Expr * Expr
```

let rec deriv expr =

```
match expr with
| Var          -> Num 1
| Num _        -> Num 0
| Sum (e1, e2) -> Sum (deriv e1, deriv e2)
| Prod (e1, e2) -> Sum (Prod (e1, deriv e2), Prod (e2, deriv e1))
```

The type of the `deriv` function is as follows:

---

```
val deriv : expr:Expr -> Expr
```

---

Now, let's find the derivative of a simple expression, say  $1+2x$ :

---

```
> let e1 = Sum (Num 1, Prod (Num 2, Var));;
val e1 : Expr = Sum (Num 1,Prod (Num 2,Var))

> deriv e1;;
val it : Expr = Sum (Num 0,Sum (Prod (Num 2,Num 1),Prod (Var,Num 0)))
```

---

The resulting expression is a symbolic representation of  $0+(2*1+x*0)$ , which indeed is 2— so it's right. You should do a couple of things next. First, install a custom printer so that F# Interactive responds using expressions that you're more used to using. Before you apply brute force and put parentheses around the expressions in each sum and product, let's contemplate it a bit. Parentheses are usually needed to give precedence to operations that would otherwise be applied later in the sequence of calculations. For instance,  $2+3*4$  is calculated as  $2+(3*4)$  because the product has a higher precedence; if you were to find  $(2+3)*4$ , you would need to use parentheses to designate the new order of calculation. Taking this argument further, you can formulate the rule for using parentheses: they're needed in places where an operator has lower precedence than the one surrounding it. You can apply this reasoning to the expression printer by passing a context precedence parameter:

```
let precSum = 10
let precProd = 20

let rec stringOfExpr prec expr =
    match expr with
    | Var -> "x"
    | Num i -> i.ToString()
    | Sum (e1, e2) ->
        let sum = stringOfExpr precSum e1 + "+" + stringOfExpr precSum e2
        if prec > precSum then
            "(" + sum + ")"
        else
            sum
    | Prod (e1, e2) ->
        stringOfExpr precProd e1 + "*" + stringOfExpr precProd e2
```

You can add this as a custom printer for this expression type:

---

```
> fsi.AddPrinter (fun expr -> stringOfExpr 0 expr);;
val it : unit = ()

> let e3 = Prod (Var, Prod (Var, Num 2));;
val e3 : Expr = x*x*2

> deriv e3;;
val it : Expr = x*(x*0+2*1)+x*2*1
```

---



Parentheses are omitted only when a sum is participating in an expression that has a higher precedence, which in this simplified example means products. If you didn't add precedence to the pretty-printer, you'd get  $x*x^0+2*1+x^2*1$  for the last expression, which is incorrect.

## Implementing Local Simplifications

The next thing to do is to get your symbolic manipulator to simplify expressions so you don't have to do so. One easy modification is to replace the use of the `Sum` and `Prod` constructors in `deriv` with local functions that perform local simplifications such as removing identity operations, performing arithmetic, bringing forward constants, and simplifying across two operations. Listing 12-6 shows how to do this.

*Listing 12-6. Symbolic Differentiation with Local Simplifications*

```
let simpSum = function
  | Num n, Num m -> Num (n+m)      // constants!
  | Num 0, e | e, Num 0 -> e        // 0+e = e+0 = e
  | e1, e2 -> Sum(e1, e2)

let simpProd = function
  | Num n, Num m -> Num (n*m)      // constants!
  | Num 0, e | e, Num 0 -> Num 0    // 0*e=0
  | Num 1, e | e, Num 1 -> e        // 1*e = e*1 = e
  | e1, e2 -> Prod(e1, e2)

let rec simpDeriv = function
  | Var          -> Num 1
  | Num _        -> Num 0
  | Sum (e1, e2) -> simpSum (simpDeriv e1, simpDeriv e2)
  | Prod (e1, e2) -> simpSum (simpProd (e1, simpDeriv e2),
                              simpProd (e2, simpDeriv e1))
```

These measures produce significant improvement over the previous naive approach, but they don't place the result in a normal form, as the following shows:

---

```
> simpDeriv e3;;
val it : Expr = x*2+x*2
```

---

However, you can't implement all simplifications using local rules; for example, collecting like terms across a polynomial involves looking at every term of the polynomial.

---

■ **Note** Listing 12-6 uses the expression form `function pattern-rules -> expression`. This is equivalent to `(fun x -> match x with pattern-rules -> expression)` and is especially convenient as a way to define functions working directly over discriminated unions.

---

## A Richer Language of Algebraic Expressions

This section goes beyond the approach presented so far and shows how to develop a UI application that can accept algebraic expressions as input and simplify, differentiate, and render them graphically. Figure 12-3 shows the project structure. To run this example, you will need to install the F# PowerPack, a collection of useful F# tools and libraries available at <http://fsharppowerpack.codeplex.com>; and add library references to `FSharp.PowerPack` from the F# PowerPack and `System.Windows.Forms` from the standard .NET libraries. For convenience, you can add the lexer `ExprLexer.fsl` and the parser `ExprParser.fsy` to the project so you can quickly edit them if necessary. You can manually include a reference to the F# PowerPack targets in the project file to automatically generate code for the parser and lexer definitions, or you can manually generate these files. You do the latter for this example, but in both cases you need to add the generated files (`ExprParser.fs` and `ExprLexer.fs`) to the project.

The main `Expr` type that represents algebraic expressions is contained in `Expr.fs`. Although you can use the expression constructors defined in this type to create expression values on the fly, the most convenient method for embedding complex expressions into this representation is by parsing them.

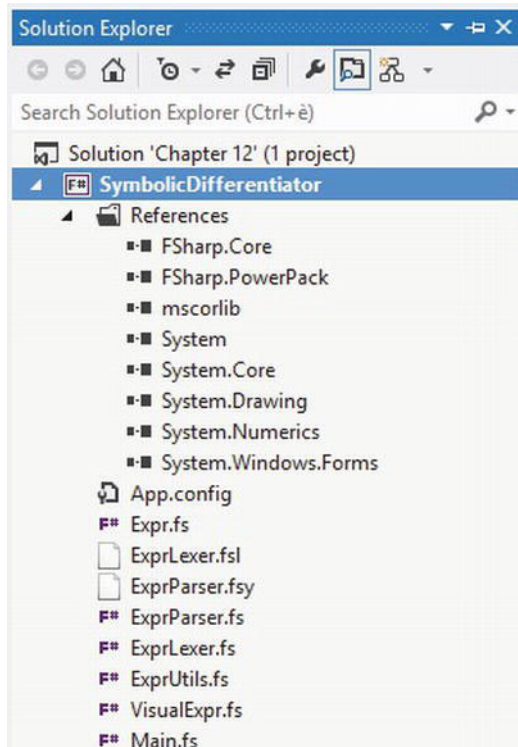

Figure 12-3. The Symbolic Differentiation Solution in Visual Studio 2012

Armed with the ability to encode and parse algebraic expressions, you place the derivation and simplification logic in its own module and file (`ExprUtil.fs`). The last piece is rendering (in `VisualExpr.fs`). Finally, a simple UI client in `Main.fs` completes the application.

Listing 12-7 shows the definition of the abstract syntax representation of expressions using a single `Expr` type. Expressions contain numbers, variables, negation, sums, differences, products, fractions, exponents, basic trigonometric functions ( $\sin x$ ,  $\cos x$ ), and  $e^x$ .

Let's look at this abstract syntax design more closely. In Chapter 9, you saw that choosing an abstract syntax often involves design choices, and that these choices often relate to the roles the abstract syntax representation should serve. In this case, you use the abstract syntax to compute symbolic derivatives and simplifications (using techniques similar to those earlier in this chapter) and also to graphically visualize the resulting expressions in a way that is pleasant for the human user. For this reason, you don't use an entirely minimalistic abstract syntax (for example, by replacing quotients with an inverse node), because it's helpful to maintain some additional structure in the input.

Here, you represent sums and differences not as binary terms (as you do for products and quotients) but instead as a list of expression terms. The `Sub` term also carries the *minuend*, the term that is to be reduced, separately. As a result, you have to apply different strategies when simplifying them.

*Listing 12-7. Expr.fs: The Core Expression Type for the Visual Symbolic Differentiation Application*

```
namespace Symbolic.Expressions
```

```
type Expr =
    | Num of decimal
    | Var of string
    | Neg of Expr
    | Add of Expr list
    | Sub of Expr * Expr list
    | Prod of Expr * Expr
    | Frac of Expr * Expr
    | Pow of Expr * decimal
    | Sin of Expr
    | Cos of Expr
    | Exp of Expr

static member StarNeeded e1 e2 =
    match e1, e2 with
    | Num _, Neg _ | _, Num _ -> true
    | _ -> false

member self.IsNumber =
    match self with
    | Num _ -> true | _ -> false

member self.NumOf =
    match self with
    | Num num -> num | _ -> failwith "NumOf: Not a Num"

member self.IsNegative =
    match self with
    | Num num | Prod (Num num, _) -> num < 0M
    | Neg e -> true | _ -> false

member self.Negate =
    match self with
    | Num num -> Num (-num)
    | Neg e -> e
    | exp -> Neg exp
```

Listing 12-7 also shows the definition of some miscellaneous augmentations on the expression type, mostly related to visual layout and presentation. The `StarNeeded` member is used internally to determine whether the multiplication operator (the star symbol, or asterisk) is needed in the product of two expressions, `e1` and `e2`. You may want to extend this simple rule: any product whose right side is a number requires the explicit operator, and all other cases don't. Thus, expressions such as  $2(x+1)$  and  $2x$  are rendered without the asterisk.

The `IsNumber` member returns `true` if the expression at hand is numeric and is used in conjunction with `NumOf`, which returns this numeric component. Similarly, the `IsNegative` and `Negate` members determine whether you have an expression that starts with a negative sign, and they negate it on demand.

## Parsing Algebraic Expressions

This sample uses a lexer and a parser generated by the F# tools `fsyacc.exe` and `fslex.exe`, available as part of the F# PowerPack. This chapter skips over the details of how the tools work; instead it assumes that you have these tools installed. Listings 12-8 and 12-9 show the code for the lexer and parser. You need to manually build the lexer (generating `ExprLexer.fs`) and parser (generating `ExprParser.fs`) from the Windows command line as follows:

---

```
C:\samples> fsyacc ExprParser.fsy --module ExprParser
C:\samples> fslex ExprLexer.fsl --unicode
```

---

*Listing 12-8. ExprLexer.fsl: Tokenizing the Concrete Syntax for Algebraic Expressions*

```
{
module ExprLexer

open System
open Microsoft.FSharp.Text.Lexing
open ExprParser

let lexeme = LexBuffer<_>.LexemeString

let special lexbuf = function
    | "+" -> PLUS    | "-" -> MINUS
    | "*" -> TIMES   | "/" -> DIV
    | "(" -> LPAREN  | ")" -> RPAREN | "^" -> HAT
    | _ -> failwith "Invalid operator"

let id lexbuf = function
    | "sin" -> SIN   | "cos" -> COS
    | "e"   -> E     | id   -> ID id
}

let digit = ['0'-'9']
let int   = digit+
let float = int ('.' int)? (['e' 'E'] int)?
let alpha = ['a'-'z' 'A'-'Z']
let id    = alpha+ (alpha | digit | ['_' '$'])*
let ws    = ' ' | '\t'
```

```

let nl      = '\n' | '\r' '\n'
let special = '+' | '-' | '*' | '/' | '(' | ')' | '^'

rule main = parse
| int      { INT      (Convert.ToInt32(lexeme lexbuf)) }
| float    { FLOAT    (Convert.ToDouble(lexeme lexbuf)) }
| id       { id       lexbuf (lexeme lexbuf) }
| special  { special  lexbuf (lexeme lexbuf) }
| ws | nl  { main     lexbuf }
| eof      { EOF      }
| _        { failwith (lexeme lexbuf) }

```

The parser has some syntactic sugar for polynomial terms, so it can parse  $2x$ ,  $2x^3$ , or  $x^4$  without requiring you to add an explicit multiplication after the coefficient.

*Listing 12-9. ExprParser.fsy: Parsing the Concrete Syntax for Algebraic Expressions*

```

%{
open System
open Symbolic.Expressions
%}

%token <int> INT
%token <float> FLOAT
%token <string> ID

%token EOF LPAREN RPAREN PLUS MINUS TIMES DIV HAT SIN COS E

%left ID
%left prec_negate
%left LPAREN
%left PLUS MINUS
%left TIMES DIV
%left HAT

%start expr
%type <Expr> expr
%%

expr:
  | exp EOF { $1 }

number:
  | INT      { Convert.ToDecimal($1) }
  | FLOAT    { Convert.ToDecimal($1) }
  | MINUS INT %prec prec_negate { Convert.ToDecimal(-$2) }
  | MINUS FLOAT %prec prec_negate { Convert.ToDecimal(-$2) }

```

```

exp:
| number                { Num $1 }
| ID                    { Var $1 }
| exp PLUS exp          { Add [$1; $3] }
| exp MINUS exp         { Sub ($1, [$3]) }
| exp TIMES exp         { Prod ($1, $3) }
| exp DIV exp           { Frac ($1, $3) }
| SIN LPAREN exp RPAREN { Sin $3 }
| COS LPAREN exp RPAREN { Cos $3 }
| E HAT exp             { Exp $3 }
| term                  { $1 }
| exp HAT number        { Pow ($1, $3) }
| LPAREN exp RPAREN     { $2 }
| MINUS LPAREN exp RPAREN { Neg $3 }

term:
| number ID                { Prod (Num $1, Var $2) }
| number ID HAT number     { Prod (Num $1, Pow (Var $2, $4)) }
| ID HAT number            { Prod (Num 1M, Pow (Var $1, $3)) }

```

## Simplifying Algebraic Expressions

At the start of this chapter, you simplified expressions using local techniques, but you also saw the limitations of this approach. Listing 12-10 shows a more complete implementation of a separate function (`Simplify`) that performs some nonlocal simplifications as well. Both this function and the one for derivation shown in the subsequent section are placed in a separate file (`ExprUtil.fs`).

`Simplify` uses two helper functions (`collect` and `negate`). The former collects constants from products using a bottom-up strategy that reduces constant subproducts and factors out constants by bringing them outward (to the left). Recall that product terms are binary.

### *Listing 12-10. ExprUtils.fs: Simplifying Algebraic Expressions*

```

module Symbolic.Expressions.Utils

open Symbolic.Expressions

/// A helper function to map/select across a list while threading state
/// through the computation
let selectFold f l s =
    let l,s' = List.fold
        (fun (l',s') x ->
            let x',s'' = f x s'
            (List.rev x') @ l',s'')
        ([],s) l
    List.rev l,s'

/// Collect constants
let rec collect = function
| Prod (e1, e2) ->
    match collect e1, collect e2 with
    | Num num1, Num num2 -> Num (num1 * num2)

```

```

| Num n1, Prod (Num n2, e)
| Prod (Num n2, e), Num n1 -> Prod (Num (n1 * n2), e)
| Num n, e | e, Num n      -> Prod (Num n, e)
| Prod (Num n1, e1), Prod (Num n2, e2) ->
  Prod (Num (n1 * n2), Prod (e1, e2))
| e1', e2'                -> Prod (e1', e2')
| Num _ | Var _ as e      -> e
| Neg e                   -> Neg (collect e)
| Add exprs               -> Add (List.map collect exprs)
| Sub (e1, exprs)         -> Sub (collect e1, List.map collect exprs)
| Frac (e1, e2)           -> Frac (collect e1, collect e2)
| Pow (e1, num)           -> Pow (collect e1, num)
| Sin e                   -> Sin (collect e)
| Cos e                   -> Cos (collect e)
| Exp _ as e              -> e

```

*/// Push negations through an expression*

```

let rec negate = function
| Num num                -> Num (-num)
| Var v as exp           -> Neg exp
| Neg e                  -> e
| Add exprs              -> Add (List.map negate exprs)
| Sub _                  -> failwith "unexpected Sub"
| Prod (e1, e2)          -> Prod (negate e1, e2)
| Frac (e1, e2)          -> Frac (negate e1, e2)
| exp                    -> Neg exp

```

*/// Simplify an expression*

```

let rec simp = function
| Num num                -> Num num
| Var v                  -> Var v
| Neg e                  -> negate (simp e)
| Add exprs ->
  let filterNums (e:Expr) n =
    if e.IsNumber
    then [], n + e.NumOf
    else [e], n
  let summands = function | Add es -> es | e -> [e]
  let exprs', num =
    selectFold (simp >> summands >> selectFold filterNums) exprs OM
  match exprs' with
  | [Num _ as n] when num = OM -> n
  | []                          -> Num num
  | [e] when num = OM           -> e
  | _ when num = OM             -> Add exprs'
  | _                           -> Add (exprs' @ [Num num])
| Sub (e1, exprs) ->
  simp (Add (e1 :: List.map Neg exprs))
| Prod (e1, e2) ->
  match simp e1, simp e2 with
  | Num num, _ | _, Num num when num = OM -> Num OM

```

```

| Num num, e | e, Num num when num = 1M -> e
| Num num1, Num num2 -> Num (num1 * num2)
| e1, e2 -> Prod (e1, e2)
| Frac (e1, e2) ->
  match simp e1, simp e2 with
  | Num num, _ when num = 0M -> Num num
  | e1, Num num when num = 1M -> e1
  | Num (_ as num), Frac (Num (_ as num2), e) ->
    Prod (Frac (Num num, Num num2), e)
  | Num (_ as num), Frac (e, Num (_ as num2)) ->
    Frac (Prod (Num num, Num num2), e)
  | e1, e2 -> Frac (e1, e2)
| Pow (e, n) when n=1M -> simp e
| Pow (e, n) -> Pow (simp e, n)
| Sin e -> Sin (simp e)
| Cos e -> Cos (simp e)
| Exp e -> Exp (simp e)

```

```
let Simplify e = e |> simp |> simp |> collect
```

The main simplification algorithm works as follows:

- Constants and variables are passed through verbatim. You use `negate` when simplifying a negation, which assumes the expression at hand no longer contains differences and that sums were flattened (see the next item in this list).
- Sums are traversed and nested sums are flattened, at the same time all constants are collected and added up. This reduces the complexity of further simplification considerably.
- Differences are converted to sums: for instance,  $A-B-C$  is converted to  $A+(-B)+(-C)$ . Thus, the first element is preserved without negation.
- When simplifying a product, you first simplify its factors, and then you remove identity operations (multiplying by zero or one) and reduce products of constants.
- Fractions are handled similarly. Zero divided by anything is 0, anything divided by 1 is itself, and multiline fractions can be collapsed if you find numeric denominators or numerators.
- The rest of the match cases deal with simplifying subexpressions.

## Symbolic Differentiation of Algebraic Expressions

Applying symbolic differentiation is a straightforward translation of the mathematical rules of differentiation into code. You could use local functions that act as constructors and perform local simplifications, but with the simplification function described earlier, this isn't needed. Listing 12-11 shows the implementation of symbolic differentiation for the `Expr` type. Note how beautifully and succinctly the code follows the math behind it: the essence of the symbolic processing is merely 20 lines of code!



*Listing 12-11. ExprUtil.fs (continued): Symbolic Differentiation for Algebraic Expressions*

```

let Differentiate v e =
    let rec diff v = function
        | Num num          -> Num OM
        | Var v' when v'=v -> Num 1M
        | Var v'           -> Num OM
        | Neg e            -> diff v (Prod ((Num -1M), e))
        | Add exprs        -> Add (List.map (diff v) exprs)
        | Sub (e1, exprs)  -> Sub (diff v e1, List.map (diff v) exprs)
        | Prod (e1, e2)    -> Add [Prod (diff v e1, e2); Prod (e1, diff v e2)]
        | Frac (e1, e2)    ->
            Frac (Sub (Prod (diff v e1, e2), [Prod (e1, diff v e2)]),
                Pow (e2, 2M))
        | Pow (e1, num)    ->
            Prod (Prod (Num num, Pow (e1, num - 1M)), diff v e1)
        | Sin e            -> Prod (Cos e, diff v e)
        | Cos e            -> Neg (Prod (Sin e, diff v e))
        | Exp (Var v') as e when v'=v -> e
        | Exp (Var v') as e when v'<>v -> Num OM
        | Exp e            -> Prod (Exp e, diff v e)
    diff v e

```

## Rendering Expressions

Now that you have the basic machinery to easily parse, simplify, and differentiate expressions, you can start looking into how to visualize them to really enjoy the benefits of the application. The rendering engine (placed in `VisualExpr.fs`) has two main parts: converting expressions to `VisualExpr` values and then rendering them directly. Ideally, you should hide the representation of the `VisualExpr` (and its related `VisualElement`) type with a signature (not shown here) so that it isn't possible to construct these values directly.

Before you get to the conversion and rendering functions, you need to do a bit of setup. To control how the different parts of an expression are rendered on the screen, you introduce the `RenderOptions` type containing the fonts and pen (which determines the color used to draw) that are applied during rendering. Listing 12-12 shows the code that defines the rendering options used in the remainder of this example.

*Listing 12-12. VisualExpr.fs: Rendering Options for the Visual Symbolic Differentiation Application*

```

namespace Symbolic.Expressions.Visual

open Symbolic.Expressions
open System.Drawing
open System.Drawing.Imaging

type RenderOptions =
    { NormalFont: Font; SmallFont: Font; IsSuper: bool; Pen: Pen; }

    static member Default =
        {
            NormalFont = new Font("Courier New", 18.0f, FontStyle.Regular)
            SmallFont = new Font("Courier New", 12.0f, FontStyle.Regular)
        }

```

```

    IsSuper = false
    Pen = new Pen(Color.Black, 1.0f)
}

```

```

member self.Brush =
    (new SolidBrush(Color.FromArgb(255, self.Pen.Color)) :> Brush)

```

Each algebraic expression is converted to a `VisualExpr` value as part of the rendering process. This ensures that you don't have to deal with the variety of expression forms but only with a small set of simple shapes that can be rendered according to a few simple rules. These simpler building blocks are defined in the `VisualElement` type and shown in Listing 12-13. For instance, there are no sums or products; these and similar expressions are broken down into sequences of symbols (such as 1, x, and +). The two other visual elements are exponentiation and fractions, which are used to guide the display logic later during the rendering phase. Each visual element carries a size value that is calculated using a given set of rendering options.

**Listing 12-13.** *VisualExpr.fs (continued): Visual Elements and Sizes for the Visual Symbolic Differentiation Application*

```

type VisualElement =
    | Symbol    of string * ExprSize
    | Power     of VisualElement * VisualElement * ExprSize
    | Sequence  of VisualElement list * ExprSize
    | Fraction  of VisualElement * VisualElement * ExprSize

member self.Size =
    match self with
    | Symbol (_, size) | Power (_, _, size)
    | Sequence (_, size) | Fraction (_, _, size) -> size

member self.Height = self.Size.Height
member self.Width  = self.Size.Width
member self.Midline = self.Size.Midline

and ExprSize =
    { Width: int; Height: int; Midline: int; }

member self.CenterOnMidline size x y =
    x + (size.Width-self.Width)/2, y + (size.Midline-self.Midline)

member self.Frac size opt =
    {
        Width = max self.Width size.Width
        Height = self.Height + size.Height + self.FracSepHeight opt
        Midline = self.Height + (self.FracSepHeight opt)/2
    }

member self.FracSepHeight (opt: RenderOptions) =
    max (int (opt.Pen.Width * 5.0f)) 4

member self.AddPower (e: VisualElement) =

```

```

    {
        Width = self.Width + e.Width
        Height = self.Height + e.Height
        Midline = self.Midline + e.Height
    }

    static member ExpandOne (size: ExprSize) (e: VisualElement) =
        {
            Width = size.Width + e.Width
            Height = max size.Height e.Height
            Midline = max size.Midline e.Midline
        }

    member self.Expand (exprs: VisualElement list) =
        List.fold ExprSize.ExpandOne self exprs

    static member Seq (exprs: VisualElement list) =
        List.fold ExprSize.ExpandOne ExprSize.Zero exprs

    static member Zero =
        { Width=0; Height=0; Midline=0; }

```

The size value encodes the dimensions (width and height in pixels) of the related visual expression and is managed through the `ExprSize` type, which provides various members to compute precise dimensions. Basically, this type handles the gory details of putting together small visuals to compose a large expression and manages how and where these small visuals should be placed. The main guideline is to align these visuals on a line (measured from the top of the expression in pixels and stored in the `Midline` field), as depicted in Figure 12-4.

The darker rectangles in this figure denote arbitrary expressions, whereas the lighter rectangles mark the dimensions of the parent expression aligned on the midline.

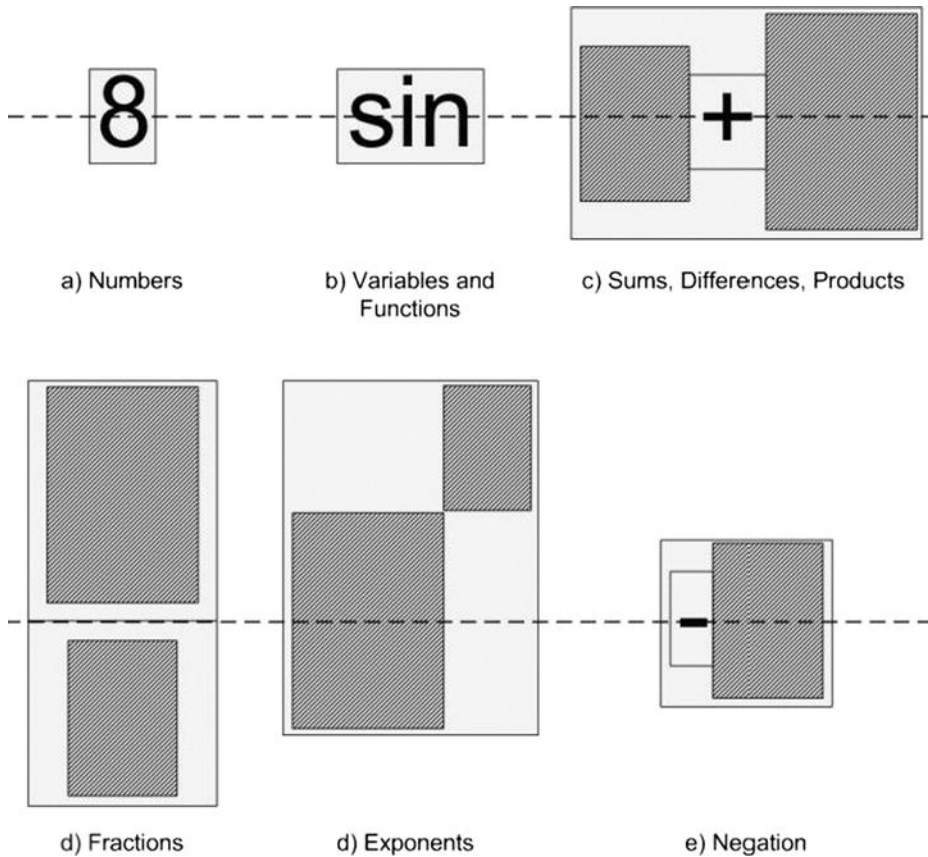

Figure 12-4. Expressions and their sizes

## Converting to VisualExpr

Listing 12-14 shows the type `VisualExpr` that carries the main visual element and the rendering options that were used to produce it. This type also provides the method `OfExpr` to build a `VisualExpr` from an `Expr`.

**Listing 12-14.** *VisualExpr.fs (continued): Visual Expressions for the Visual Symbolic Differentiation Application*

```
type VisualExpr =
    { Expression : VisualElement; RenderOptions: RenderOptions; }

    static member OfExpr (opt: RenderOptions) e =
        use bmp = new Bitmap(100, 100, PixelFormat.Format32bppArgb)
        use gra = Graphics.FromImage(bmp)
        let sizeOf (opt: RenderOptions) s =
            use sFormat = new StringFormat(StringFormat.GenericTypographic)
            let font = if opt.IsSuper then opt.SmallFont else opt.NormalFont
            let size = gra.MeasureString(s, font, PointF(0.0f, 0.0f), sFormat)
            let height = int size.Height
```

```

    {
      Width = int size.Width + 2
      Height = height
      Midline = height/2
    }
let precPow = 70
let precProd1, precProd2 = 30, 40
let precAdd1, precAdd2 = 10, 11
let precStart = 5
let precNeg1, precNeg2 = 1, 20
let sym opt s = Symbol (s, sizeOf opt s)

let applyPrec opt pprec prec exprs (size: ExprSize) =
  if pprec > prec then
    sym opt "(" :: exprs @ [sym opt ")"],
    size.Expand [sym opt "("; sym opt ")"]
  else
    exprs, size

let mkSequence opt pprec prec exprs =
  let size = ExprSize.Seq exprs
  let exprs, size = applyPrec opt pprec prec exprs size
  Sequence (exprs, size)

let rec expFunc opt f par =
  let f' = sym opt f
  let exprs' = [sym opt "("; exp opt precStart par; sym opt ")"]
  Sequence (f' :: exprs', f'.Size.Expand exprs')

and exp (opt: RenderOptions) prec = function
| Num n ->
  let s = n.ToString() in Symbol (s, sizeOf opt s)
| Var v ->
  Symbol (v, sizeOf opt v)
| Neg e ->
  let e' = exp opt precNeg1 e
  let exprs, size = applyPrec opt prec precNeg1 [e'] e'.Size
  let exprs' = [sym opt "-"] @ exprs
  mkSequence opt prec precNeg2 exprs'
| Add exprs ->
  let exprs' =
    [ for i,e in Seq.mapi (fun i x -> (i,x)) exprs do
      let first = (i=0)
      let e' = exp opt (if first then precAdd1 else precAdd2) e
      if first || e.IsNegative
      then yield! [e']
      else yield! [sym opt "+"; e'] ]
  mkSequence opt prec precAdd1 exprs'
| Sub (e1, exprs) ->
  let e1' = exp opt prec e1
  let exprs' =

```

```

    [ for e in exprs do
      if e.IsNegative then
        let e' = exp opt precAdd2 e.Negate
        yield! [sym opt "+"; e']
      else
        let e' = exp opt precAdd2 e
        yield! [sym opt "-"; e' ]

    mkSequence opt prec precAdd1 (e1'::exprs')
| Prod (e1, e2) ->
  let e1' = exp opt precProd1 e1
  let e2' = exp opt precProd2 e2
  let exprs' =
    if Expr.StarNeeded e1 e2
    then [e1'; sym opt "*"; e2']
    else [e1'; e2']
  mkSequence opt prec precProd1 exprs'
| Pow (e1, e2) ->
  let e1' = exp opt precPow e1
  let e2' = exp { opt with IsSuper=true } precPow (Num e2)
  Power (e1', e2', e1'.Size.AddPower e2')
| Sin e ->
  expFunc opt "sin" e
| Cos e ->
  expFunc opt "cos" e
| Exp expo ->
  let e' = sym opt "e"
  let expo' = exp { opt with IsSuper=true } precPow expo
  Power (e', expo', e'.Size.AddPower expo')

| Frac (e1, e2) ->
  let e1' = exp opt precStart e1
  let e2' = exp opt precStart e2
  Fraction (e1', e2', e1'.Size.Frac e2'.Size opt)
let exp = exp opt precStart e
{ Expression=exp; RenderOptions=opt; }

```

The conversion implemented in Listing 12-14 is relatively straightforward. It uses various local helper functions to break each expression into smaller visual elements, carefully keeping track of the bounding-box calculation. There are a number of things to consider: precedence is enforced, and expressions are parenthesized as necessary. For example, consider how you convert a product:

```

| Prod (e1, e2) ->
  let e1' = exp opt precProd1 e1
  let e2' = exp opt precProd2 e2
  let exprs' =
    if Expr.StarNeeded e1 e2
    then [e1'; sym opt "*"; e2']
    else [e1'; e2']
  mkSequence opt prec precProd1 exprs'

```

This code converts the two interior expressions and decides on a list of display symbols by first checking whether a multiplication symbol is required. The function `mkSequence` then calculates the size of this new list of expressions, applies precedence rules to determine whether parentheses are required, and produces a final visual element as a result.

Other cases are handled similarly; for sums, you iterate through the elements `exprs` in the sum using sequence expression notation. If you find a negative term, you omit the plus sign (so `1+(-2)` is rendered as `1-2`). Differences are treated similarly, but here you change negative terms to positive, so `3-2-(-1)` becomes `3-2+1`. When converting products, you omit the multiplication operator if you can.

## Rendering

Listing 12-15 shows the code for rendering visual expressions. You may have noticed in the definition of the `VisualElement` type that the only directly drawable visual element is `Symbol`. The other constructors carry one or more visual elements that must be drawn recursively and according to a well-defined logic. The key observation in the rendering function in Listing 12-15 is that, when drawing each element, you pass in the `x` and `y` coordinates of the bounding box in which it's to be drawn. You also pass in the size of the parent box in which the element is to be aligned (as guided by the `midline` property).

*Listing 12-15. VisualExpr.fs (continued): Rendering Visual Expressions*

```
type VisualExpr =
    ...
    member self.Render =
        let pt x y = PointF(float32 x, float32 y)
        let rec draw (gra: Graphics) opt x y psize = function
            | Symbol (s, size) ->
                let font =
                    if opt.IsSuper then opt.SmallFont else opt.NormalFont
                let x', y' = size.CenterOnMidline psize x y
                gra.DrawString(s, font, opt.Brush, pt x' y')
            | Power (e1, e2, size) ->
                let x', y' = size.CenterOnMidline psize x y
                draw gra opt x' (y'+e2.Height) e1.Size e1
                draw gra { opt with IsSuper=true } (x'+e1.Width) y' e2.Size e2
            | Sequence (exps, size) ->
                let x', y' = size.CenterOnMidline psize x y
                List.fold (fun (x, y) (e: VisualElement) ->
                    let psize' =
                        {
                            Width = e.Width
                            Height = psize.Height;
                            Midline =size.Midline
                        }
                    draw gra opt x y psize' e
                    x+e.Width, y) (x', y') exps |> ignore
            | Fraction (e1, e2, size) as e ->
                let psize1 =
                    { psize with Height=e1.Height; Midline=e1.Midline }
                let psize2 =
                    { psize with Height=e2.Height; Midline=e2.Midline }
                draw gra opt x y psize1 e1
```

```

        gra.DrawLine(self.RenderOptions.Pen, x, y+size.Midline,
                    x+psize.Width, y+size.Midline);
        draw gra opt x (y+e1.Height+size.FracSepHeight opt) psize2 e2
let bmp = new Bitmap(self.Expression.Width, self.Expression.Height,
                    PixelFormat.Format32bppArgb)
let gra = Graphics.FromImage(bmp)
gra.FillRectangle(new SolidBrush(Color.White), 0, 0,
                 self.Expression.Width+1, self.Expression.Height+1)
draw gra self.RenderOptions 0 0 self.Expression.Size self.Expression
bmp

```

## Building the User Interface

Listing 12-16 is the final piece: the UI client (`Main.fs`). It's simple yet powerful. The main form contains an input field and a preview panel where the expressions are rendered on the fly as typed in. When the user presses the Enter key, a new MDI child window is created, and the original, simplified, derived, and final expressions are rendered on it. A bit of extra work is involved in creating the child windows to make them scrollable.

*Listing 12-16. `Main.fs`: The User Interface Client for the Visual Symbolic Differentiation Application*

```

module Symbolic.Expressions.UI

open Symbolic.Expressions
open Symbolic.Expressions.Visual
open System.Windows.Forms
open System.Drawing

let CreateScrollableChildWindow parent =
    let scroll = new ScrollableControl(Dock=DockStyle.Fill, AutoScroll=true)
    let form2 = new Form(MdiParent=parent, BackColor=Color.White)
    form2.Controls.Add scroll
    form2, scroll

let NewExpression parent s es =
    let form, scroll = CreateScrollableChildWindow parent
    let AddLabel (top, maxw) (parent: Control) s =
        let l = new Label(Text=s, AutoSize=true, Top=top)
        parent.Controls.Add l
        (top+l.Height), max maxw l.Width
    let AddPic (top, maxw) (parent: Control) (e: Expr) =
        let e' = VisualExpr.OfExpr RenderOptions.Default e
        let bmp = e'.Render
        let pic = new PictureBox(Image=bmp, Height=bmp.Height,
                                Width=bmp.Width, Top=top)
        parent.Controls.Add pic
        (top+bmp.Height), max maxw bmp.Width
    let height, width = List.fold (fun top (lab, e) ->
        AddPic (AddLabel top scroll lab) scroll e) (0, 0) es
    form.Text <- s
    form.Height <- min 640 (height+40)
    form.Width <- min 480 (width+40)
    form.Show()

```



```

let UpdatePreview (scroll: Control) e =
    let e' = VisualExpr.OfExpr RenderOptions.Default e
    let bmp = e'.Render
    let pic = new PictureBox(Image=bmp, Height=bmp.Height, Width=bmp.Width)
    scroll.Controls.Clear()
    scroll.Controls.Add pic

let NewExpressionError form s =
    let cform, scroll = CreateScrollableChildWindow form
    let label = new Label(Text=s, Font=new Font("Courier New", 10.f), AutoSize=true)
    scroll.Controls.Add label
    cform.Show()

exception SyntaxError

let Parse s =
    let lex = Lexing.LexBuffer<char>.FromString s
    try ExprParser.expr ExprLexer.main lex
    with _ -> raise SyntaxError

let NewStringExpression form s =
    try
        let e1 = Parse s
        let e2 = Utils.Simplify e1
        let e3 = Utils.Differentiate "x" e2
        let e4 = Utils.Simplify e3
        NewExpression form s ["Original:", e1; "Simplified:", e2;
                             "Derivative:", e3; "Simplified:", e4]
    with
        | SyntaxError ->
            let msg = Printf.sprintf "Syntax error in:\n%s" s
            NewExpressionError form msg
        | Failure msg ->
            NewExpressionError form msg

let ConstructMainForm () =
    let form = new Form(Text="Symbolic Differentiation Example",
                       IsMdiContainer=true,
                       Visible=true, Height=600, Width=700)
    let label = new Label(Text="Enter function=", Width=100, Height=20)
    let tb = new TextBox(Width=150, Left=100)
    let panel = new Panel(Dock=DockStyle.Top, Height=tb.Height+50)
    let preview = new Panel(Dock=DockStyle.Bottom, BackColor=Color.White,
                           Height=50, BorderStyle=BorderStyle.FixedSingle)
    panel.Controls.AddRange([|label; preview; tb |])
    form.Controls.Add(panel)
    tb.KeyUp.Add (fun arg ->
        if arg.KeyCode = Keys.Enter then
            NewStringExpression form tb.Text
            tb.Text <- ""
            tb.Focus() |> ignore
        else
    )

```

```

    try
        let e = Parse tb.Text
        UpdatePreview preview e
    with
    | _ -> ()
form

```

```

let form = ConstructMainForm ()
NewStringExpression form "cos(sin(1/(x^2+1)))"
Application.Run(form)

```

To recap, in this example you've seen the following:

- Two abstract syntax representations for different classes of algebraic expressions: one simple, and one much more realistic
- How to implement simplification and symbolic differentiation routines on these representations of algebraic expressions
- How to implement parsing and lexing for concrete representations of algebraic expressions
- How to perform size estimation and visual layout for abstract syntax representations of algebraic expressions, here using Windows Forms
- How to put this together into a final application

## Summary

This chapter looked at two applications of language-oriented symbolic programming. The first was hardware modeling and verification using propositional logic and binary decision diagrams, where you saw how to use symbolic techniques to describe circuits as propositional logic formulae and then used brute-force and/or binary decision diagram techniques to analyze these for correctness. The second was algebraic symbolic differentiation and visualization, where you learned how to differentiate, simplify, and display algebraic expressions. These examples are only two of many in the large domain of symbolic computation problems, a domain where functional programming and F# truly excels.



# Integrating External Data and Services

One of the major trends in modern computing is “the data deluge,” meaning the rapid rise in availability of massive quantities of digital information available for analysis, especially through reliable networked services and large-scale data storage systems. Some of this data may be collected by an individual or an organization, some may be acquired from data providers, and some from free data sources.

In this world, programmed services and applications can be viewed as components that consume, filter, transform and re-publish information within a larger connected and reactive system. Nearly all modern software components or applications incorporate one or more external information sources. This may include static data in tables, static files copied into your application, data coming from relational databases, data coming from networked services (including the web or the local enterprise network), or data from the ambient context of sensors and devices. When the whole web is included, there are an overwhelming number of data sources which you might use, and hundreds more appearing every month! The digital world is exploding with information, almost beyond imagination.

For example, consider the data provided by the World Bank (<http://api.worldbank.org>), which includes thousands of data sets for hundreds of countries. From one perspective, this is a lot of data: it would take you a long time to learn and explore all this, and there are a lot of practical things you can do with it. However, from another perspective, the World Bank data is *tiny*: it is just one data source hidden in one remote corner of the Internet which you’ve probably never heard of until just now.

Because the world of external data is so big, in this chapter we can’t hope to describe how to use every data source, or even every “kind” of data source. We also can’t cover the incredible range of things you might want to do with different data sources. Instead, this chapter introduces a selection of topics in data-rich programming. Along the way you get to use and learn some important and innovative F# features related to this space.

- You first learn some simple and pragmatic techniques to work with external web data using HTTP REST requests, XML, and JSON.
- You then look at how F# 3.0 allows for language integration of some schematized data sources through the *type provider* feature introduced in this version of the language. You learn how to use the F# built-in type providers to query OData REST services and SQL databases directly from F# code in a more immediate way.
- You then learn how to author more advanced queries, including sorting, grouping, joins, and statistical aggregates.

- You then look at how to use the lower-level ADO.NET libraries for some data programming tasks for relational databases.

Along the way, remember that the role of F# is as a workhorse to help control the complexity of working with external data.

## Some Basic REST Requests

We begin our adventures in working with external information sources by looking at some simple examples of making HTTP REST requests to web-hosted resources. You have already used the basic code to make an HTTP request in Chapters 2 and 3:

```
open System.IO
open System.Net

let http (url: string) =
    let req = WebRequest.Create(url)
    use resp = req.GetResponse()
    use stream = resp.GetResponseStream()
    let reader = new StreamReader(stream)
    reader.ReadToEnd()
```

You have used this function to fetch web pages containing HTML, but it can also be used to fetch structured data in formats such as XML and JSON from web-hosted services. For example, one such service is the World Bank API mentioned in the introduction to this chapter. This service exposes a data space containing *regions*, *countries* and *indicators*, where the indicators are a time-series of time/value pairs. You can fetch the list of countries by using:

```
let worldBankCountriesXmlPage1 = http "http://api.worldbank.org/country"
```

This fetches the first page of the country list as XML, and the results will be like this:

---

```
val worldBankCountriesXmlPage1 : string =
  "<?xml version='1.0' encoding='utf-8'?>
  <wb:countries page='1'+[25149 chars]

> worldBankCountriesXmlPage1;;

val it : string =
  "<?xml version='1.0' encoding='utf-8'?>
  <wb:countries page='1' pages='5' per_page='50' total='246' xmlns:wb='http://www.worldbank.
  org'>
  <wb:country id='ABW'>
    <wb:iso2Code>AW</wb:iso2Code>
    <wb:name>Aruba</wb:name>
    <wb:region id='LCN'>Latin America & Caribbean (all income levels)</wb:region>
    <wb:adminregion id='' />
    <wb:incomeLevel id='NOC'>High income: nonOECD</wb:incomeLevel>
    <wb:lendingType id='LNX'>Not classified</wb:lendingType>
    <wb:capitalCity>Oranjestad</wb:capitalCity>
    <wb:longitude>-70.0167</wb:longitude>
    <wb:latitude>12.5167</wb:latitude>
```

```

</wb:country>
<wb:country id="AFG">
...
</wb:country>
...
</wb:countries>"

```

---

## Getting Data in JSON Format

Web data sources typically support both XML and JSON result formats. For example, you can fetch the same data in JSON format as follows:

```
let worldBankCountriesJsonPage1 = http "http://api.worldbank.org/country?format=json"
```

The results will then look like this:

---

```
val worldBankCountriesJsonPage1 : string =
  "[{"page":1,"pages":5,"per_page":"50","total":246},{{"id":"ABW"+[17322 chars]
```

---

## Parsing the XML or JSON Data

Once we have the resulting XML or JSON data back from the service, we can parse it using techniques you have already seen from Chapters 8 and 9:

```

#r "System.Xml.Linq.dll"
open System.Xml.Linq

/// The schema tag for this particular blob of XML
let xmlSchemaUrl = "http://www.worldbank.org"

// General utilities for XML
let xattr s (el: XElement) = el.Attribute(XName.Get(s)).Value
let xelem s (el: XElement) = el.Element(XName.Get(s, xmlSchemaUrl))
let xelems s (el: XElement) = el.Elements(XName.Get(s, xmlSchemaUrl))
let xvalue (el: XElement) = el.Value

/// The results of parsing
type Country = { Id: string; Name: string; Region: string; }

/// Parse a page of countries from the WorldBank data source
let parseCountries xml =
  let doc = XDocument.Parse xml
  [ for countryXml in doc |> xelem "countries" |> xelems "country" do
    let region = countryXml |> xelem "region" |> xvalue
    yield
      {
        Id = countryXml |> xattr "id"
        Name = countryXml |> xelem "name" |> xvalue
        Region = region
      }
  ]

```

This extracts some of the fields from each of the <country> nodes in the returned XML. When we execute the XML parsing over the first page of input data, we get:

---

```
> parseCountries worldBankCountriesXmlPage1;
val it : Country list =
  [{Id = "ABW";
    Name = "Aruba";
    Region = "Latin America & Caribbean (all income levels)"};
  ...
  {Id = "CYM";
    Name = "Cayman Islands";
    Region = "Latin America & Caribbean (all income levels)"}]
```

---

Parsing data in JSON format can be done in a similar way using a library such as NewtonSoft's Json.NET, from [json.codeplex.com](http://json.codeplex.com).

## Handling Multiple Pages

Web-hosted services like the WorldBank API are “stateless” – they will essentially respond to identical requests with identical responses. Accessing services like this uses a technique known as REST, which stands for *REpresentational State Transfer*. This means that any “state” is passed back and forth between the client and the services as data.

One simple example of this works is how we collect multiple pages of data from the services. So far, we have only retrieved the first page of countries. If we want to collect all the pages, we need to make multiple requests, where we give a page parameter. For example, we can get the second page as follows:

```
let worldBankCountriesXmlPage2 = http "http://api.worldbank.org/country?page=2"
```

Note that the “state” of the process of iterating through the collection is passed simply by using a different URL, one with “page=2” added. This is very typical of REST requests.

The total number of pages can be fetched by parsing the first page, which contains the total page count as an attribute. If using XML, we use the following:

```
let doc = XDocument.Parse worldBankCountriesXmlPage1
let totalPageCount = doc |> xelem "countries" |> xattr "pages" |> int
```

When executed, this reveals a total page count of 5:

---

```
val totalPageCount : int = 5
```

---

We can now put this together into a function that fetches all the pages through a sequence of requests, as follows:

```
let rec getCountryPages() =
  let page1 = http "http://api.worldbank.org/country"
  let doc1 = XDocument.Parse page1
  let numPages = doc1 |> xelem "countries" |> xattr "pages" |> int
  let otherPages =
    [ for i in 2 .. numPages ->
      http ("http://api.worldbank.org/country?page=" + string i) ]
  [ yield! parseCountries page1
```

```
for otherPage in otherPages do
    yield! parseCountries otherPage ]
```

When executed, this reveals a total country count of 246 at the time of writing:

---

```
> getCountryPages() |> Seq.length;;
val it : int = 246
```

---

As an alternative, you can often simply increase a REST parameter that indicates how many results to return per page. For example, in the case of the WorldBank API this is the `per_page` parameter, e.g. this URL:

```
http://api.worldbank.org/country?format=json&per_page=1000
```

This will return all the results in a single page which can then be parsed. However, not all services allow arbitrarily high numbers of items per page so parsing multiple pages is still often necessary.

## Getting Started with Type Providers and Queries

In the first section you performed some basic REST requests in F#. However, you will have noticed that working with external information in this way is somewhat tedious because you must manually construct REST API calls and manually parse the XML or JSON returned by the service. This gets progressively harder as services become more complex, as services change, and as additional features like authentication are required. Further, it is very easy to make mistakes in all parts of this process, including parsing the XML or JSON.

In this section, we look at a unique F# language/tooling feature called *type providers* which is designed to make information sources directly available in the F# language in simpler, more intuitive, and more directly strongly-typed way.

### Example - Language Integrated OData

Our first example is accessing an internet data protocol using F# programming. We use “OData” (see [www.odata.org](http://www.odata.org)) as our example. Here is the code to access the data service:

```
#r "System.Data.Services.Client.dll"
#r "FSharp.Data.TypeProviders.dll"
open Microsoft.FSharp.Data.TypeProviders

type Northwind =
    ODataService<"http://services.odata.org/Northwind/Northwind.svc/">

let db = Northwind.GetDataContext()
```

In this code, you first reference two libraries: the “runtime” library for OData services `System.Data.Services.Client`, and the F# library for the F# 3.0 OData type provider `FSharp.Data.TypeProviders.dll`. You can now get data from the service as follows:

```
let first10Customers =
    query { for c in db.Customers do
            take 10
```

```

        select c }
|> Seq.toList

```

When run, this gives the first 10 customers from the OData service:

---

```

> first10Customers;;
val it : Northwind.ServiceTypes.Customer list =
  [Customer {Address = "Obere Str. 57";
             City = "Berlin";
             CompanyName = "Alfreds Futterkiste";
             ContactName = "Maria Anders";
             ContactTitle = "Sales Representative";
             Country = "Germany";
             CustomerDemographics = seq [];
             CustomerID = "ALFKI";
             Fax = "030-0076545";
             Orders = seq [];
             Phone = "030-0074321";
             PostalCode = "12209";
             Region = null;};...]

```

---

To understand what's going on, it's helpful to add the following line before executing the code above:

```
service.DataContext.SendingRequest.Add (fun x -> printfn "requesting %A" x.Request.RequestUri)
```

After you add this, you will see that the output begins:

---

```
requesting http://services.odata.org/Northwind/Northwind.svc/Customers()?&top=10
```

---

As you can see, OData is a protocol for querying data sources over HTTP, and is ultimately implemented by REST requests. The code above accesses the data service at `services.odata.org/Northwind/Northwind.svc`. Under the hood, an OData service request is a URL with embedded strings to represent queries. The response text is JSON or XML, which is automatically turned back into objects for you.

## What is a Type Provider?

The example above uses two things that you have not yet seen in this book: a use of a type provider, and a use of an F# query. The use of the type provider is here:

```

open Microsoft.FSharp.Data.TypeProviders

type Northwind =
    ODataService<"http://services.odata.org/Northwind/Northwind.svc/">

```

A type provider is a compile-time component that, given optional static parameters identifying an external information space, provides two things to the host F# compiler/tooling:

- A component “signature” that acts as the programming interface to that information space, and which is computed on-demand as needed by the F# compiler. For F#, the component signature contains provided namespaces, types, methods, properties,



events, attributes, and literals that give a .NET object-oriented characterization of the information space.

- An implementation of the component signature. This is given by either an actual .NET assembly that implements the component signature (the generative model for the provided types), or a pair of erasure functions giving representation types and representation expressions for the provided types and provided methods respectively (the erasure model for the provided types).

Put simply, type providers are about using a provider model for the “type import” logic of the host language compiler or tooling. Essentially, a type provider is an adapter component that reads schematized data and services and transforms them into types in the target programming language. This allows programmers to quickly leverage rich, schematized information sources without an explicit transcription process (be it code generation or a manually created ontology). The provided types can then be leveraged by not only the type-checker and runtime, but also by tools that rely on the type-checker, such as IDE auto-completion. Also, if the data source contains additional descriptive metadata (such as a description of various columns in a database), this can be transformed by the type provider into information that is visible to the programmer within the IDE (such as documentation contained in tooltips).

A type provider does not necessarily contain any types itself; rather, it is a component for generating descriptions of types, methods, and their implementations. A type provider is thus a form of compile-time meta-programming: a compiler plugin that augments the set of types that are known to the type-checker and compiler. Importantly, a type provider can provide types and methods on-demand, i.e. lazily, as the information is required by the host tool such as the F# compiler. This allows the provided type space to be very large or even infinite.

## What is a Query?

The second new construct in the code above is a *query*, in particular this program text:

```
query { for c in db.Customers do
    take 10
    select c }
```

If you know C# you will recognize this as a way of writing LINQ queries. A LINQ query is simply a way of specifying a query of a data source using a set of operators such as `select`, `where`, `take`, and so on. In F#, the code inside `query { ... }` is converted by a “LINQ query provider” into an actual request that is sent to the data provider—in this particular case, a REST request sent to the OData service. This translation relies on the F# compiler to insert quotations automatically, and using the underlying quotation representation to convert the inner F# expression to a LINQ query that can be iterated over. You’ve seen one example already of how this translation works, where the code above becomes:

---

```
requesting http://services.odata.org/Northwind/Northwind.svc/Customers()?$top=10
```

---

You can experiment with this particular implementation of query translation from F# queries to OData. For example, the simpler:

```
query { for c in db.Customers do
    select c }
```

uses the URL:

---

```
requesting http://services.odata.org/Northwind/Northwind.svc/Customers()
```

---

and this more complex query:

```
query { for c in db.Customers do
    where (c.ContactName.Contains "Maria")
    take 10
    select c }
```

yields this request:

---

```
requesting http://services.odata.org/Northwind/Northwind.svc/Customers()
?$filter=substringof('Maria',ContactName)&$top=10
```

---

You will learn more about queries and query translation later in this chapter.

---

## QUERYING ODATA – NOT QUITE AS EASY AS IT LOOKS

---

This section has used the F# 3.0 support for the OData protocol as an example of integrating a remote data source into F# programming. While OData gives a great “in-the-box” example of F# type providers, it turns out that querying OData is actually quite a bit harder than we’ve made it look in this section. This isn’t really anything to do with F#—it is mostly to do with the OData query implementation itself in the .NET Framework and because so far we’ve ignored some important issues like authentication.

So, in the name of full disclosure, we state openly that querying OData with F# 3.0 (or C# 5.0) is actually full of a surprising number of subtleties. Here is a quick guide:

- **Queries should select an entity.** Select an entity (e.g., a customer *c*) rather than a property of an entity (such as *c.Name*). Selecting a property of an entity gives a cryptic error message about “Navigation properties.”
- **Queries returning simple entities are easy.** Simple entities have properties which are all primitive types like integers, strings, dates, and GUIDs.
- **Queries returning complex entities need “Expand.”** If the data being returned contains further entities (e.g. a *Customer* contains a list of *Orders*), then things become surprisingly harder and you must “expand” those entities. If not, the corresponding data will appear as empty! You will see examples of how to do this later in this chapter. A quick example is:

```
query { for c in db.Customers.Expand("Orders") do
    select c }
```

- **If you expand, only query the DataContext once.** When you expand some nested entities, these get placed in the reified graph of objects for the OData context. If you have already queried the data context, you will not see the expanded data. *So, if you need to expand, make sure you haven’t already used the data context for other queries against that collection!*
- **Learn what you can use in filters.** Filters (where) can use a range of methods. For example, on strings you can use *.StartsWith*, *.EndsWith*, *.Replace*, *.ToLower*, *.ToUpper*, *.Trim*, *.Substring*, *.Length* and on *DateTime* values you can use *.Year*, *.Month*, *.Day*, *.Hour*, *.Minute*, *.Second*.

- **\* Learn what you can use in queries.** Queries can use `from`, `where`, `sortBy`, `thenBy`, `select`, `skip` and `take` plus uses of `.Expand`. You can't really use anything else in OData queries. Don't try.
- **Learn how to get paged data.** OData service implementations usually only return the first 20 to 100 results of a query. To get the remaining results you need to use "pagination." This is a common pattern for all service-oriented programming. You will see examples of doing OData pagination later in this chapter.
- **If using credentials, set them in the `SendingRequest` callback.** OData services may need credentials, usually either using Basic or OAuth authentication. To set them, use the following for Basic:

```
db.DataContext.SendingRequest.Add(fun e ->
    e.RequestHeaders["Authorization"] <- "Basic " + base64 encoding of
    "username:password")
```

and the following for OAuth:

```
db.DataContext.SendingRequest.Add(fun e ->
    e.RequestHeaders["Authorization"] <- "OAuth " + securityToken)
```

- **On some platforms, you need to use asynchronous requests.** In Silverlight and Windows 8, the OData implementations only allow asynchronous requests, in order to avoid blocking the UI thread. If on a UI thread, you will need to use async programming in F# (see Chapter 11). If already on a background thread, you can make a synchronous request like this:

```
Async.FromBeginEnd(q.BeginExecute, q.EndExecute) |> Async.RunSynchronously
```

Paginated requests are a little harder; you will need a similarly modified version of the pagination code shown later in this chapter.

---

## Handling Pagination in OData

As mentioned in the side bar above, OData service implementations usually only return the first 20 to 100 results of a query. To get the remaining results, you need to use "pagination." This is a common pattern for all service-oriented programming, but is particularly tricky for F#. Here is a function you can use to collect paginated results into a single sequence:

```
open System.Data.Services.Client
open System.Linq

let executePaginated (ctxt: DataServiceContext) (query: IQueryable<'T>) =
    match query with
    | :? DataServiceQuery<'T> as q ->
        seq {
            let rec loop (cont: DataServiceQueryContinuation<'T>) = seq {
                if cont <> null then
                    let rsp = ctxt.Execute cont
                    yield! rsp
                    yield! loop (rsp.GetContinuation())
            }
            let rsp = q.Execute()
```

```

        yield! rsp
        let cont = (rsp :?) QueryOperationResponse<'T>).GetContinuation()
        yield! loop cont }
| _ -> query.AsEnumerable()

```

You use it like this:

```

let allCustomersQuery =
    query { for c in db.Customers do select c }
    |> executePaginated db.DataContext
    |> Seq.toList

```

## Example - Language Integrated SQL

For our second example of working with data through a type provider, we use data drawn from a relational database and queried using SQL. The following sections show how to perform relational database queries using F# 3.0 queries. F# 3.0 uses F# quotation metaprogramming to represent SQL queries. These are then translated across to SQL and executed using the Microsoft LINQ libraries that are part of .NET Framework 4.0 or higher.

We assume you're working with the `Northwnd.mdf` database, a common database used in many database samples. You can download this sample database as part of the F# Power Pack, or from many other sources on the Web.

The code to access the database is very simple and remarkably similar to that used to access OData:

```

#r "System.Data.Linq.dll"
#r "FSharp.Data.TypeProviders.dll"

open Microsoft.FSharp.Linq
open Microsoft.FSharp.Data.TypeProviders

type NorthwndDb =
    SqlConnectionString =
        @"AttachDBFileName = 'C:\Scripts\northwnd.mdf';
        Server='. \SQLEXPRESS';User Instance=true;Integrated Security=SSPI",
        Pluralize=true>

let db = NorthwndDb.GetDataContext()

```

In this code, you first reference two libraries: the “runtime” library for SQL data access `System.Data.Linq`, and the F# library for the F# 3.0 SQL type providers called `FSharp.Data.TypeProviders.dll`. You then create an instance of a “data context” to access the database. You can now get data from the service as follows:

```

let customersSortedByCountry =
    query { for c in db.Customers do
        sortBy c.Country
        select (c.Country, c.CompanyName) }
    |> Seq.toList

```

When run, this gives the full list of customers from the database:

---

```
val customersSortedByCountry : (string * string) list =
  [("Argentina", "Cactus Comidas para llevar");
   ("Argentina", "Océano Atlántico Ltda."); ("Argentina", "Rancho grande");
   ...
   ("Venezuela", "LINO-Delicatesses"); ("Venezuela", "HILARION-Abastos");
   ("Venezuela", "GROSELLA-Restaurante")]
```

---

To understand what's going on, it's helpful to add the following line before executing the code above:

```
db.DataContext.Log <- System.Console.Out
```

After you add this, you will see that the output begins:

---

```
SELECT [t0].[Country] AS [Item1], [t0].[ContactName] AS [Item2]
FROM [dbo].[Customers] AS [t0]
ORDER BY [t0].[Country]
-- Context: SqlProvider(Sql2008) Model: AttributedMetaModel Build: 4.0.30319.17929
```

---

As you can see, the query has been converted into SQL text and sent to the relational database for execution. A slightly more complex query is shown below:

```
let selectedEmployees =
  query { for emp in db.Employees do
    where (emp.BirthDate.Value.Year > 1960)
    where (emp.LastName.StartsWith "S")
    select (emp.FirstName, emp.LastName)
    take 5 }
  |> Seq.toList
```

The results are as follows (only one employee is ultimately selected):

---

```
SELECT TOP (5) [t0].[FirstName] AS [Item1], [t0].[LastName] AS [Item2]
FROM [dbo].[Employees] AS [t0]
WHERE ([t0].[LastName] LIKE @p0) AND (DATEPART(Year, [t0].[BirthDate])) > @p1
-- @p0: Input NVarChar (Size = 4000; Prec = 0; Scale = 0) [S%]
-- @p1: Input Int (Size = -1; Prec = 0; Scale = 0) [1960]
-- Context: SqlProvider(Sql2008) Model: AttributedMetaModel Build: 4.0.30319.17929

val selectedEmployees : (string * string) list = [("Michael", "Suyama")]
```

---

## More on Queries

In this section, you will learn how to perform a number of relational query operations in the F# query syntax.

## Sorting

The sorting operations in queries are `sortBy`, `sortByDescending`, `thenBy`, `thenByDescending`, and their corresponding versions for nullable values such as `sortByNullable`. These are added to a query starting with one of the `sortBy` operations (for the first sorting key) and a sequence of `thenBy` operations (for secondary and subsequent sorting keys). Sorting is done in ascending order unless the “descending” variations are used. For example:

```
let customersSortedTwoColumns =
    query { for c in db.Customers do
            sortBy c.Country
            thenBy c.Region
            select (c.Country, c.Region, c.CompanyName) }
    |> Seq.toList
```

Giving:

---

```
val customersSortedTwoColumns : (string * string * string) list =
    [("Argentina", null, "Cactus Comidas para llevar");
     ("Argentina", null, "Océano Atlántico Ltda.");
     ("Argentina", null, "Rancho grande"); ("Austria", null, "Piccolo und mehr");
     ("Austria", null, "Ernst Handel"); ("Belgium", null, "Maison Dewey");
     ...
     ("Venezuela", "DF", "GROSELLA-Restaurante");
     ("Venezuela", "Lara", "LILA-Supermercado");
     ("Venezuela", "Nueva Esparta", "LINO-Delicatesses");
     ("Venezuela", "Táchira", "HILARION-Abastos)"]
```

---

## Aggregation

Aggregation operations (sum, average, maximum, minimum) are performed by using the query operators `sumBy`, `sumByNullable`, `averageBy`, `averageByNullable`, `maxBy`, `maxByNullable`, `minBy` or `minByNullable`. For example:

```
let totalOrderQuantity =
    query { for order in db.OrderDetails do
            sumBy (int order.Quantity) }

let customersAverageOrders =
    query { for c in db.Customers do
            averageBy (float c.Orders.Count) }
```

Giving:

---

```
val totalOrderQuantity : int = 51317
val customersAverageOrders : float = 9.120879121
```

---

## Nullables

Data in SQL tables, OData services and other data sources may be missing values. When using these data sources via the usual type providers or code generators for F# (e.g. `ODataService`, `SqlDataProvider` and `SqlEntityProvider`), the potential for missing primitive values is represented using the .NET type `System.Nullable<_>`.

Full techniques to handle nullable values are discussed in the MSDN documentation for F# queries. Here we show just some examples. For example, to compute the average price over the range of products on offer, you can use `averageByNullable`:

```
let averagePriceOverProductRange =
    query { for p in db.Products do
            averageByNullable p.UnitPrice }
```

Giving:

---

```
val averagePriceOverProductRange : System.Nullable<decimal> = 28.8663M
```

---

Note that the result of the averaging is itself a nullable value.

Working with nullable values can be slightly awkward in F#. Here are some techniques to use:

- Very often, you will need to eliminate nullable values using either the `.Value` property, or the `.GetValueOrDefault()` method. You can also call conversion functions such `int` or `float`.
- To create a nullable value, use the constructor for the `System.Nullable` type, e.g., `System.Nullable(3)`.
- To compare, add, subtract, multiply, or divide nullable values, use the special operators such as `?+?` in `Microsoft.FSharp.Linq.NullableOperators`.

## Inner Queries

It is very common to use one or more “inner” queries to collect information about an entity before selecting it. For example, consider the task of writing a query which iterates the customers, sums the number of orders (if any), and finds the average unit price of orders (if any) for that customer. Here is the query:

```
let totalOrderQuantity =
    query { for c in db.Customers do
            let numOrders =
                query { for o in c.Orders do
                        for od in o.OrderDetails do
                            sumByNullable (Nullable(int od.Quantity)) }
            let averagePrice =
                query { for o in c.Orders do
                        for od in o.OrderDetails do
                            averageByNullable (Nullable(od.UnitPrice)) }
            select (c.ContactName, numOrders, averagePrice) }
|> Seq.toList
```

Giving:

---

```
val totalOrderQuantity :
  (string * System.Nullable<int> * System.Nullable<decimal>) list =
  [("Maria Anders", 174, 26.7375M); ("Ana Trujillo", 63, 21.5050M);
   ("Antonio Moreno", 359, 21.7194M); ("Thomas Hardy", 650, 19.1766M);
   ...
   ("Zbyszek Piestrzeniewicz", 205, 20.6312M)]
```

---

## Grouping

The previous example showed how to use inner queries to compute and return a number of statistical properties of an entity using a query. Very often, this is instead done over a group of entities. To group entities, you use the `groupBy .. into ...` operator:

```
let productsGroupedByAndCountedTest1 =
  query { for p in db.Products do
    groupBy p.Category.CategoryName into group
    let sum =
      query { for p in group do
        sumBy (int p.UnitsInStock.Value) }
    select (group.Key, sum) }
  |> Seq.toList
```

Giving:

---

```
val productsGroupedByAndCountedTest1 : (string * int) list =
  [("Beverages", 559); ("Condiments", 507); ("Confections", 386);
   ("Dairy Products", 393); ("Grains/Cereals", 308); ("Meat/Poultry", 165);
   ("Produce", 100); ("Seafood", 701)]
```

---

## Joins

You can write both normal SQL joins and “group” joins using F# queries. For example, a simple join is written as follows:

```
let innerJoinQuery =
  query { for c in db.Categories do
    join p in db.Products on (c.CategoryID =? p.CategoryID)
    select (p.ProductName, c.CategoryName) } //produces flat sequence
  |> Seq.toList
```

The operator `=?` is a nullable comparison operator, mentioned in the previous section, because `p.CategoryID` may be missing. This gives:

---

```
val innerJoinQuery : (string * string) list =
  [("Chai", "Beverages"); ("Chang", "Beverages");
   ("Aniseed Syrup", "Condiments");
   ...
   ("Lakkalikööri", "Beverages");
   ("Original Frankfurter grüne Soße", "Condiments")]
```

---



As it happens, many joins are actually implicit in F# queries over types provided by the usual type providers. For example, the above query could have been written:

```
let innerJoinQuery =
    query { for p in db.Products do
            select (p.ProductName, p.CategoryName) }
    |> Seq.toList
```

Likewise, you can also write “group joins”, where the inner iteration results in an overall group of elements that satisfy the joining constraint. For example:

```
let innerGroupJoinQueryWithAggregation =
    query { for c in db.Categories do
            groupJoin p in db.Products on (c.CategoryID =? p.CategoryID) into prodGroup
            let groupMax = query { for p in prodGroup do maxByNullable p.UnitsOnOrder }
            select (c.CategoryName, groupMax) }
    |> Seq.toList
```

This gives:

---

```
val innerGroupJoinQueryWithAggregation : (string * Nullable<int16>) list =
    [("Beverages", 40s); ("Condiments", 100s); ("Confections", 70s);
     ("Dairy Products", 70s); ("Grains/Cereals", 80s); ("Meat/Poultry", 0s);
     ("Produce", 20s); ("Seafood", 70s)]
```

---

## More on Relational Databases and ADO.NET

So far in this chapter, you have seen how to perform simple “raw” HTTP web requests to an information service, and how to use the type provider and query mechanisms to access OData and SQL data in a more directly strongly typed, and clear way.

However, it is often necessary to access databases in a “raw” way as well. To do this, you use the ADO.NET library which has been part of .NET since its first releases. Like web requests, this is a “lowest common denominator” way of doing information access from F# code. While it is usually nicer to use the type provider mechanism where possible, this is not always possible for all databases, and is also not really possible for cases where you are creating tables dynamically. Further, some data access standards (e.g. ODBC, a common data connectivity standard developed in the late 1990s) will definitely require you to use lower level libraries that look a lot like ADO.NET. Note that you can also use the newer Entity Framework to work with databases on a higher conceptual level. However, in this current discussion, we are mostly concerned with low-level details such as programmatically creating tables, executing update and insert statements, and querying using plain SQL code.

First, however, we examine databases more generally and give a guide to your choices about which database to use in the first place. Databases provide many benefits. Some of the more important ones are listed here:

- *Data security*: When you have centralized control of your data, you can erect a full security system around the data, implementing specific access rules for each type of access or parts of the database.
- *Sharing data*: Any number of applications with the appropriate access rights can connect to your database and read the data stored within—without needing to worry about containing the logic to extract this data. As you will see shortly,

applications use various query languages (most notably SQL) to communicate with databases.

- *A logical organization of data:* You can write new applications that work with the same data without having to worry about how the data is physically represented and stored. On the basic level, this logical structure is provided by a set of entities (data tables) and their relationships.
- *Avoiding data redundancy:* Having all requirements from each consuming application up front helps to identify a logical organization for your data that minimizes possible redundancy. For instance, you can use foreign keys instead of duplicating pieces of data. *Data normalization* is the process of systematically eliminating data redundancy, a large but essential topic that we don't consider in this book.
- *Transactions:* Reading from and writing to databases occurs atomically, and as a result, two concurrent transactions can never leave data in an inconsistent, inaccurate state. *Isolation levels* refer to specific measures taken to ensure transaction isolation by locking various parts of the database (fields, records, tables). Higher isolation levels increase locking overhead and can lead to a loss of parallelism by rendering concurrent transactions sequential; on the other hand, no isolation can lead to inconsistent data.
- *Maintaining data integrity:* Databases make sure data is stored accurately. Having no redundancy is one way to maintain data integrity (if a piece of data is changed, it's changed in the only place it occurs; thus, it remains accurate); on the other hand, data security and transaction isolation are needed to ensure that the data stored is modified in a controlled manner.

Table 13-1 shows some of the most common database engines, all of which can be used from F# and .NET.

*Table 13-1. Common Databases*

Name	Type	Description	Available From
PostgreSQL	Open source	Open source database engine	<a href="http://www.postgresql.org">www.postgresql.org</a>
SQLite	Open source	Small, embeddable, zero-configuration SQL database engine	<a href="http://www.sqlite.org">www.sqlite.org</a>
DB2	Commercial	IBM's database engine	<a href="http://www-01.ibm.com/software/data/db2/ad/dotnet.html">www-01.ibm.com/software/data/db2/ad/dotnet.html</a>
Firebird	Open source	Based on Borland Interbase	<a href="http://www.firebirdsql.org">www.firebirdsql.org</a>
MySQL	Open source	Reliable and popular database	<a href="http://www.mysql.com">www.mysql.com</a>
Mimer SQL	Commercial	Reliable database engine	<a href="http://www.mimer.com">www.mimer.com</a>
Oracle	Commercial	One of the most popular enterprise database engines	<a href="http://www.oracle.com">www.oracle.com</a>
SQL Server	Commercial	Microsoft's main database engine	<a href="http://www.microsoft.com/sql">www.microsoft.com/sql</a>
SQL Server Express	Commercial	Free and easy-to-use version of SQL Server	<a href="http://www.microsoft.com/express/database">www.microsoft.com/express/database</a>
Sybase iAnywhere	Commercial	Mobile database engine	<a href="http://www.iAnywhere.com">www.iAnywhere.com</a>

Applications communicate with relational databases using Structured Query Language (SQL). Each time you create tables, create relationships, insert new records, or update or delete existing ones, you are explicitly or implicitly issuing SQL statements to the database. The examples in this chapter use a dialect of Standard SQL called Transact-SQL (T-SQL), used by SQL Server and SQL Server Express. SQL has syntax to define the structure of a database schema (loosely speaking, a collection of data tables and their relations) and also syntax to manage the data within. These subsets of SQL are called *Data Definition Language* (DDL) and *Data Manipulation Language* (DML), respectively.

ADO.NET is the underlying database-access machinery in the .NET Framework, and it provides full XML support, disconnected and typed datasets, scalability, and high performance. This section gives a brief overview of the ADO.NET fundamentals.

With ADO.NET, data is acquired through a *connection* to the database via a provider. This connection serves as a medium against which to execute a *command*; this can be used to fetch, update, insert, or delete data from the data store. Statements and queries are articulated as SQL text (CREATE, SELECT, UPDATE, INSERT, and DELETE statements) and are passed to the command object's constructor. When you execute these statements, you obtain data (in the case of queries) or the number of affected rows (in the case of UPDATE, INSERT, and DELETE statements). The data returned can be processed via two main mechanisms: sequentially in a read-only fashion using a *DataReader* object or by loading it into an in-memory representation (a *DataSet* object) for further disconnected processing. *DataSet* objects store data in a set of table objects along with metadata that describes their relationships and constraints in a fully contained model.

## Establishing Connections using ADO.NET

Before you can do any work with a database, you need to establish a connection to it. For instance, you can connect to a locally running instance of SQL Server Express using the following code:

```
open System.Data
open System.Data.SqlClient

let connString = @"Server=.\SQLEXPRESS;Integrated Security=SSPI"
let conn = new SqlConnection(connString)
```

The value `connString` is a connection string. Regardless of how you created your connection object, to execute any updates or queries on it, you need to open it first:

---

```
> conn.Open();;
```

---

If this command fails, then you may need to do one of the following:

- Consult the latest SQL Server Express samples for alternative connection strings.
- Add `UserInstance='true'` to the connection string. This starts the database engine as a user-level process.
- Change the connection string if you have a different database engine installed and running (for instance, if you're using SQL Server instead of SQL Server Express).

Connections established using the same connection string are pooled and reused depending on your database engine. Connections are often a limited resource and should generally be closed as soon as possible within your application.

## Creating a Database using ADO.NET

Now that you've established a connection to the database engine, you can explicitly create a database from F# code by executing a SQL statement directly. For example, you can create a database called `company` as follows:

```
open System.Data
open System.Data.SqlClient

let execNonQuery conn s =
    let comm = new SqlCommand(s, conn, CommandTimeout = 10)
    comm.ExecuteNonQuery() |> ignore

execNonQuery conn "CREATE DATABASE company"
```

You use `execNonQuery` in the subsequent sections. This method takes a connection object and a SQL string and executes it as a SQL command, ignoring its result.

---

■ **Note** If you try to create the same database twice, you receive a runtime exception. However, if you intend to drop an existing database, you can do so by issuing a `DROP DATABASE company` SQL command. The `DROP` command can also be used for other database artifacts, including tables, views, and stored procedures.

---

## Creating Tables using ADO.NET

You can execute a simple SQL command to create a table; all you need to do is specify its data fields and their types and whether null values are allowed. The following example creates an `Employees` table with a primary key `EmpID` and `FirstName`, `LastName`, and `Birthday` fields:

```
execNonQuery conn "CREATE TABLE Employees (
    EmpID int NOT NULL,
    FirstName varchar(50) NOT NULL,
    LastName varchar(50) NOT NULL,
    Birthday datetime,
    PRIMARY KEY (EmpID))"
```

You can now insert two new records as follows:

```
execNonQuery conn "INSERT INTO Employees (EmpId, FirstName, LastName, Birthday)
VALUES (1001, 'Joe', 'Smith', '02/14/1965')"
```

```
execNonQuery conn "INSERT INTO Employees (EmpId, FirstName, LastName, Birthday)
VALUES (1002, 'Mary', 'Jones', '09/15/1985')"
```

and retrieve two columns of what was inserted using a fresh connection and a data reader:

```
let query() =
    seq {
        use conn = new SqlConnection(connString)
        conn.Open()
        use comm = new SqlCommand("SELECT FirstName, Birthday FROM Employees", conn)
        use reader = comm.ExecuteReader()
        while reader.Read() do
```

```

        yield (reader.GetString 0, reader.GetDateTime 1)
    }

```

When you evaluate the query expression in F# Interactive, a connection to the database is created and opened, the command is built, and the reader is used to read successive elements:

---

```

> fsi.AddPrinter(fun (d: System.DateTime) -> d.ToString());;
> query();;
val it : seq<string * System.DateTime> =
    seq [("Joe", 14/02/1965 12:00:00AM); ("Mary", 15/09/1985 12:00:00AM)]

```

---

The definition of query uses sequence expressions that locally define new `IDisposable` objects such as `conn`, `comm`, and `reader` using declarations of the form `use var = expr`. These ensure that the locally defined connection, command, and reader objects are disposed after exhausting the entire sequence. See Chapters 4, 8, and 9 for more details about sequence expressions of this kind.

F# sequences are on-demand (that is, lazy), and the definition of query doesn't open a connection to the database. This is done when the sequence is first iterated; a connection is maintained until the sequence is exhausted.

Note that the command object's `ExecuteReader` method returns a `DataReader` instance that is used to extract the typed data returned from the query. You can read from the resulting sequence in a straightforward manner using a sequence iterator. For instance, you can use a simple anonymous function to print data on the screen:

---

```

> query() |> Seq.iter (fun (fn, bday) -> printfn "%s has birthday %0" fn bday);;
Joe has birthday 14/02/1965 00:00:00
Mary has birthday 15/09/1985 00:00:00

```

---

The query brings the data from the database in-memory, although still as a lazy sequence. You can then use standard F# in-memory data transformations on the result:

---

```

> query()
  |> Seq.filter (fun (nm, bday) -> bday < System.DateTime.Parse("01/01/1985"))
  |> Seq.length;;
val it : int = 1

```

---

However, be aware that these additional transformations are happening in-memory and not in the database.

The command object has different methods for executing different queries. For instance, if you have a statement, you need to use the `ExecuteNonQuery` method (for `UPDATE`, `INSERT`, and `DELETE` statements, as previously in `execNonQuery`), which returns the number of rows affected (updated, inserted, or deleted), or the `ExecuteScalar` method, which returns the first column of the first row of the result, providing a fast and efficient way to extract a single value, such as the number of rows in a table or a result set.

In the previous command, you extracted fields from the result rows using `GetXXX` methods on the reader object. The particular methods have to match the types of the fields selected in the SQL query, and

a mismatch results in a runtime `InvalidCastException`. For these and other reasons, `DataReader` tends to be suitable only in situations when the following items are true:

- You need to read data only in a sequential order (as returned from the database). `DataReader` provides forward-only data access.
- The field types of the result are known, and the query isn't configurable.
- You're reading only and not writing data. `DataReader` provides read-only access.
- Your use of the `DataReader` is localized. The data connection is open throughout the reader loop.

Database connections are precious resources, and you should always release them as soon as possible. In the previous case, you did this by using a locally defined connection. It's also sufficient to implicitly close the reader by constructing it with the `CloseConnection` option that causes it to release and close the data connection upon closing the reader instance.

Common options include `SchemaOnly`, which you can use to extract field information only (without any data returned); `SingleResult` to extract a single value only (the same as using the `ExecuteScalar` method discussed earlier); `SingleRow` to extract a single row; and `KeyInfo` to extract additional columns (appended to the end of the selected ones) automatically that uniquely identify the rows returned.

## Using Stored Procedures via ADO.NET

Stored procedures are defined and stored in your relational database and provide a number of benefits over literal SQL. First, they're external to the application and thus provide a clear division of the data logic from the rest of the application. This enables you to make data-related modifications without having to change application code or having to redeploy the application. Second, they're stored in the database in a prepared or compiled form and thus are executed more efficiently than literal SQL statements (although those can be prepared as well at a one-time cost, they're still contained in application space, which is undesirable). Supplying arguments to stored procedures instantiates the compiled formula.

In Visual Studio, you can add stored procedures just like any other database artifacts using the Server Explorer window: right-click the Stored Procedures item in the appropriate database, and select Add New Stored Procedure. Doing so creates a stored procedure template that you can easily customize. Alternatively, you can add stored procedures programmatically using the `CREATE PROCEDURE SQL` command. Consider the following stored procedure that returns the first and last names of all employees whose last name matches the given pattern:

```
execNonQuery conn "
CREATE PROCEDURE dbo.GetEmployeesByLastName ( @Name nvarchar(50) ) AS
    SELECT Employees.FirstName, Employees.LastName
    FROM Employees
    WHERE Employees.LastName LIKE @Name"
```

You can wrap this stored procedure in a function as follows:

```
let GetEmployeesByLastName (name: string) =
    use comm = new SqlCommand("GetEmployeesByLastName", conn,
        CommandType = CommandType.StoredProcedure)
    comm.Parameters.AddWithValue("@Name", name) |> ignore
    use adapter = new SqlDataAdapter(comm)
    let table = new DataTable()
    adapter.Fill(table) |> ignore
    table
```

You can execute the stored procedure as follows to find employees with the last name Smith:

---

```
> for row in GetEmployeesByLastName("Smith").Rows do
    printfn "row = %0, %0" (row.Item "FirstName") (row.Item "LastName");

row = Joe, Smith
```

---

## Using WSDL Services

Since around 2000, a popular web service protocol has been WSDL. The use of this protocol is now declining, but it is still common to find useful WSDL web service implementations, particularly in enterprises. In this section, you learn how to access a WSDL service from F#.

WSDL web services can be easily consumed in F# in much the same way as OData web services by using the `WsdService` type provider that comes with F#. For example, consider the weather service at <http://www.websvc.com/globalweather.asmx?wsdl>. This can be accessed using the following code:

```
#r "System.ServiceModel.dll"
#r "FSharp.Data.TypeProviders.dll"

open Microsoft.FSharp.Data.TypeProviders

type Weather = WsdService<"http://www.websvc.com/globalweather.asmx?wsdl">

let ws = Weather.GetGlobalWeatherSoap();;

let weatherInCanberra = ws.GetWeather("Canberra", "Australia")
```

In this case, the result is just XML giving the weather at the given location:

---

```
val weatherInCanberra : string =
  "<?xml version='1.0' encoding='utf-16'?>
<CurrentWeather>
  <Location>Canberra, Australia (YSCB) 35-18S 149-11E 580M</Location>
  <Time>Aug 14, 2012 - 12:00 PM EDT / 2012.08.14 1600 UTC</Time>
  <Wind> from the E (080 degrees) at 7 MPH (6 KT):0</Wind>
  <Visibility> greater than 7 mile(s):0</Visibility>
  <SkyConditions> partly cloudy</SkyConditions>
  <Temperature> 35 F (2 C)</Temperature>
  <Wind>Windchill: 28 F (-2 C):1</Wind>
  <DewPoint> 33 F (1 C)</DewPoint>
  <RelativeHumidity> 93%</RelativeHumidity>
  <Pressure> 30.00 in. Hg (1016 hPa)</Pressure>
  <Status>Success</Status>
</CurrentWeather>"
```

---

Often, WSDL web services return structured, strongly typed results, and no further XML parsing is required.

## Summary

In this chapter, you learned about how the growing availability of data is changing programming, forcing programmers to incorporate more data and network access code into their applications. You learned both low-level and high-level techniques for accessing a range of web, database, and service technologies. Along the way, you learned the basics of two important F# features that are used for data access: F# queries and F# type providers. Together these give an elegant and direct way of integrating data into your programs. You also learned low-level techniques for REST requests and database access with ADO.NET. These are pragmatic techniques that allow you to do more, but less directly.

The next chapter continues on the theme of web programming by looking at a range of topics in delivering content via the Web, from delivering HTML directly to writing full web applications using WebSharper, the web application framework for F#.



## CHAPTER 14



# Building Smart Web Applications

Delivering content and applications via web browsers is one of the most important aspects of modern software development. This chapter examines how you can build web applications using F#. The topics covered are:

- Serving static files and dynamic content by directly responding to HTTP requests
- Techniques to build client-based web applications with WebSharper, the main F# web framework
- A walkthrough of the main WebSharper features, including pagelets, sitelets, formlets, and flowlets
- Using dynamic templates and sitelets to build WebSharper applications
- Building sitelets that handle different HTTP requests
- Using dependent formlets and flowlets to model user interface dependencies and wizard-like sequences of web forms
- Defining resources and attaching them to different code units
- A brief overview of developing WebSharper extensions to third-party JavaScript libraries
- Defining WebSharper proxies to extend the JavaScript translation coverage to additional .NET types

## Serving Web Content the Simple Way

When you point your browser at a web page or call a web service from your application, you're effectively issuing one or more requests (commands) to a web (HTTP) server. HTTP commands are simple text-based instructions that are automatically generated by your web browser. For instance, when your browser goes to a particular URL, it:

- Requests the page from the web server and waits for the response
- Analyzes the contents of the page in the response for further content to be fetched (images, for example), and issues the appropriate requests if necessary
- Displays the results, and executes any dynamic scripts and content contained in the page

A response can be a verbatim copy of a resource found on the web server (most often a static file such as an image, a style sheet, or a media file) or can be generated on the fly. This section shows how you can use F# to serve content directly.

Listing 14-1 shows a simple web server written directly in F#.

*Listing 14-1. A Simple Web Server*

```
open System.Net
open System.Net.Sockets
open System.IO
open System.Text.RegularExpressions
open System.Text

/// A table of MIME content types.
let mimeTypes =
    dict [".html", "text/html";
          ".htm", "text/html";
          ".txt", "text/plain";
          ".gif", "image/gif";
          ".jpg", "image/jpeg";
          ".png", "image/png"]

/// Compute a MIME type from a file extension.
let getMimeType(ext) =
    if mimeTypes.ContainsKey(ext) then mimeTypes.[ext]
    else "binary/octet"

/// The pattern Regex1 uses a regular expression to match one element.
let (|Regex1|_|) (patt : string) (inp : string) =
    try Some(Regex.Match(inp, patt).Groups.Item(1).Captures.Item(0).Value)
    with _ -> None

/// The root for the data we serve
let root = @"c:\inetpub\wwwroot"

/// Handle a TCP connection for an HTTP GET request.
let handleRequest (client: TcpClient) (port: int) =
    async {
        use stream = client.GetStream()
        use out = new StreamWriter(stream)
        let sendHeaders (lines: seq<string>) =
            let printLine = fprintf out "%s\r\n"
            Seq.iter printLine lines
            // An empty line is required before content, if any.
            printLine ""
            out.Flush()
        let notFound () = sendHeaders ["HTTP/1.0 404 Not Found"]
        let inp = new StreamReader(stream)
        let request = inp.ReadLine()
        match request with
            // Requests to root are redirected to the start page.
```

```

| "GET / HTTP/1.0" | "GET / HTTP/1.1" ->
  sendHeaders <|
    [
      "HTTP/1.0 302 Found"
      sprintf "Location: http://localhost:%d/iisstart.htm" port
    ]
| Regexp1 "GET /(.*?) HTTP/1\\.\\.[01]$" fileName ->
  let fname = Path.Combine(root, fileName)
  let mimeType = getMimeType(Path.GetExtension(fname))
  if not <| File.Exists(fname) then notFound()
  else
    let content = File.ReadAllBytes fname
    sendHeaders <|
      [
        "HTTP/1.0 200 OK";
        sprintf "Content-Length: %d" content.Length;
        sprintf "Content-Type: %s" mimeType
      ]
    stream.Write(content, 0, content.Length)
| _ ->
  notFound()
}

/// The server as an asynchronous process. We handle requests sequentially.
let server =
  let port = 8090
  async {
    let socket = new TcpListener(IPAddress.Parse("127.0.0.1"), port)
    socket.Start()
    while true do
      use client = socket.AcceptTcpClient()
      do! handleRequest client port
  }

```

You can use this code as follows, where `http` is the function defined in Chapter 2 for requesting web pages and where you assume the directory `c:\inetpub\wwwroot` contains the file `iisstart.htm`:

---

```

> Async.Start server;;
val it : unit = ()

> http "http://localhost:8090";;
val it : string = "... " // the text of the iisstart.htm file will be shown here

```

---

This HTTP request (you can also open the previous URL in a browser) ultimately sends the following text down the TCP socket connection:

```
GET iisstart.htm HTTP/1.1
```

When started, the server in Listing 14-1 attaches itself to a given port (8090) on the local machine (which has IP 127.0.0.1) and listens for incoming requests. These requests are line-based, so when one

comes in, you read the full input line and attempt to parse a valid GET request using regular expression matching. Other commands and error recovery aren't dealt with.

The server's actions in response are simple: it locates the requested file relative to a root web directory, determines the MIME type from a fixed table, and sends the necessary response header and content of the file through the client TCP connection. When all this is done, the connection is disposed, and the session ends. The main loop of the server task is a busy waiting loop, so you busy wait for requests indefinitely and handle them one by one.

Listing 14-1 uses two techniques not directly related to web programming:

- `Regex1` is a simple and common *active pattern* for regular expression pattern matching. You learned about active patterns in Chapter 9. This example is particularly interesting because it also shows how to use a parameterized active pattern.
- The value `server` is an asynchronous task, as is the `handleRequest` function. You learned about asynchronous tasks in Chapter 11. Many web servers handle multiple requests simultaneously, and high-performance web servers use asynchronous techniques extensively. In this example, the server task serves requests sequentially using a single thread, but you can just as well start a dedicated thread for the server using more explicit threading techniques from `System.Threading`.

While the above example may look simple, many common server-side applications are primarily TCP-based, and you can use the pattern shown above to implement many of these. For example, the following encapsulates an arbitrary TCP server:

```
type AsyncTcpServer(addr, port, handleServerRequest) =
    let socket = new TcpListener(addr, port)

    member x.Start() = async { do x.Run() } |> Async.Start

    member x.Run() =
        socket.Start()
        while true do
            let client = socket.AcceptTcpClient()
            async {
                try do! handleServerRequest client with e -> ()
            }
        |> Async.Start
```

This class can now be instantiated and developed in many ways, including more interesting applications than simple HTTP servers. For example, the code below is a simulation of a “quote server” that serves “quotes” (represented here as a blob of bytes) to a TCP client every 1 second. Because serving each quote is very simple (simply writing a few bytes to the socket), you can serve many thousands of clients simultaneously using this technique.

```
module Quotes =
    let private quoteSize = 8
    let private quoteHeaderSize = 4
    let private quoteSeriesLength = 3

    module Server =
        let HandleRequest (client: TcpClient) =
            // Dummy header and quote
            let header = Array.init<byte> quoteSize (fun i -> 1uy)
            let quote = Array.init<byte> quoteSize (fun i -> byte(i % 256))
            async {
```

```

        use stream = client.GetStream()
        do! stream.AsyncWrite(header, 0, quoteHeaderSize) // Header
        for _ in [0 .. quoteSeriesLength] do
            do! stream.AsyncWrite(quote, 0, quote.Length)
            // Mock an I/O wait for the next quote
            do! Async.Sleep 1000
        }

let Start () =
    let S = new AsyncTcpServer(IPAddress.Loopback,10003,HandleRequest)
    S.Start()

module Client =
    let RequestQuote =
        async {
            let client = new TcpClient()
            client.Connect(IPAddress.Loopback, 10003)
            use stream = client.GetStream()
            let header = Array.create quoteHeaderSize Ouy
            let! read = stream.AsyncRead(header, 0, quoteHeaderSize)
            if read = 0 then return () else printfn "Header: %A" header
            while true do
                let buffer = Array.create quoteSize Ouy
                let! read = stream.AsyncRead(buffer, 0, quoteSize)
                if read = 0 then return () else printfn "Quote: %A" buffer
            }
        }
    |> Async.Start

```

Additionally, you should consider using secure sockets (HTTPS) for your application. Secure network programming is a vast topic, beyond the scope of this book, but the code below indicates the basic shape of an SSL server, built compositionally using a non-secure one, and indicates the .NET types you can use to implement authentication-related functionality:

```

open System.Net.Security
open System.Security.Authentication
open System.Security.Cryptography.X509Certificates

AsyncTcpServerSecure(addr, port, handleServerRequest) =

    // Gets the first certificate with a friendly name of localhost.
    let getCertificate() =
        let store = new X509Store(StoreName.My, StoreLocation.LocalMachine)
        store.Open(OpenFlags.ReadOnly)
        let certs =
            store.Certificates.Find(
                findType = X509FindType.FindBySubjectName,
                findValue = Dns.GetHostName(),
                validOnly = true)
        seq {
            for c in certs do if c.FriendlyName = "localhost" then yield Some(c)
        }
        yield None
    |> Seq.head

let handleServerRequestSecure (client : TcpClient) =
    async {
        let cert = getCertificate()
        if cert.IsNone then printfn "No cert"; return ()
        let stream = client.GetStream()
    }

```

```

let sslStream = new SslStream(innerStream = stream, leaveInnerStreamOpen = true)
try
    sslStream.AuthenticateAsServer(
        serverCertificate = cert.Value,
        clientCertificateRequired = false,
        enabledSslProtocols = SslProtocols.Default,
        checkCertificateRevocation = false)
with _ -> printfn "Can't authenticate"; return()

printfn "IsAuthenticated: %A" sslStream.IsAuthenticated
if sslStream.IsAuthenticated then
    // In this example only the server is authenticated.
    printfn "IsEncrypted: %A" sslStream.IsEncrypted
    printfn "IsSigned: %A" sslStream.IsSigned

    // Indicates whether the current side of the connection
    // is authenticated as a server.
    printfn "IsServer: %A" sslStream.IsServer

return! handleRequestStream stream
}

let server = AsyncTcpServer(addr, port, handleServerRequestSecure)

member x.Start() = server.Start()

```

TCP-based applications achieve excellent scaling, and cloud-computing solutions such as Azure allow you to host your TCP-based services on a load-balanced set of machines dedicated to serving requests under one common TCP address. The modern Web is built with server-side programs following the architectures similar to those laid out above.

## Building Ajax Rich Client Applications

In recent years, a new class of rich-client web applications has emerged, leading to what is commonly called the *Ajax* development paradigm. This is a general term for any web application that incorporates substantial amounts of code executed on the client side of the application by running JavaScript in the web browser.

You can develop Ajax applications in at least three ways using F#:

- You can manually write and serve additional JavaScript files as part of your web application. This isn't hard, but you don't benefit from existing frameworks.
- You can use the Ajax support via ASP.NET and develop Ajax web applications with F# code-behind files or F# library code exposed via C# or VB code-behind.
- You can use WebSharper (<http://websharper.com>) to write both client and server code in F#.

Developing Ajax applications with the first two techniques follows a fairly standard path mostly independent of F#. The remainder of this section gives a brief overview of some of the core WebSharper features, including *sitelets*, *pagelets*, *formlets*, and *flowlets*.

WebSharper enables rapid, client-based web application development with F# and provides a wealth of composable primitives to build web applications from small to large-scale. These represent an extremely powerful way of writing robust, efficient, integrated client/server applications in a single, type-

checked framework. In particular, WebSharper employs several advanced features of F#, the combination of which offers a unique programming experience for developing web applications:

- Client-side and server-side code are marked with custom attributes and can be authored in a single F# project. Client-side code, called *pagelets*, is automatically translated to JavaScript using F# quotations and reflection and is served to the client on demand. (See Chapter 17 for details on F# quotations and reflection.)
- The program runs initially as an ASP.NET-compatible server-side application, generating JavaScript code to populate and handle the interactions of the web user interface. WebSharper plays nicely with MVC (and includes project templates for it as well) and can easily be adopted to be used in conjunction with Web API as well.
- Web forms can be expressed in an extraordinarily compact form as first-class, type-safe values and are represented as *formlets*. They can be composed and enhanced with just a few lines of code, including adding validation and complex user interactions, and defining *dependent* formlets.
- Sequences of web forms, *flowlets*, are first-class values, providing an elegant and concise way to express larger-than-page functionality, yet remaining in Ajax space.
- The client-side code can use functionality from many .NET and F# libraries. The calls are mapped to corresponding JavaScript functionality through sophisticated techniques. You can also provide custom proxies to any .NET type, describing how to translate it to JavaScript.
- The client side may make calls to any JavaScript technology via WebSharper stubs implemented for that technology. At the time of writing, WebSharper comes with a number of extensions to various JavaScript libraries, including jQuery, jQuery UI, Google Maps, Google Visualization, ExtJS, Sencha Touch, Yahoo UI, and jQuery Mobile, among others.
- The client side may make asynchronous calls to the server using variations on the techniques described in Chapter 11.
- The resulting web applications are dramatically shorter and easier to maintain and extend, and can be readily deployed under IIS on the top of ASP.NET, or in any other ASP.NET-compatible web container.

## Learning More from the WebSharper Documentation

While this section serves as a quick and somewhat thorough introduction to WebSharper and some of its features, you may want to consult the main WebSharper documentation for more details. This documentation is largely found in the main WebSharper PDF book, which sits in the /doc folder of your local WebSharper installation, or alternatively you can download it from <http://websharper.com/websharper.pdf>.

In addition, you can read more about the core WebSharper features such as sitelets and formlets online at <http://websharper.com/docs>, and you can check out the samples on the main WebSharper page. These samples come with fully annotated descriptions, the code you can copy and paste into your own projects, and you can even try them live.

## Getting Started with WebSharper

WebSharper is open source and available free of charge for open source projects. It's the recommended way of developing Rich Internet Applications (RIAs) with F#. You can grab the latest version of WebSharper from <http://websharper.com/downloads>.

WebSharper installs as a set of tools, most notably the F# to JavaScript compiler, and various Visual Studio project templates to build WebSharper applications. These templates, shown in Figure 14-1, come in different flavors and enable you to build WebSharper applications based on traditional ASP.NET, ASP.NET MVC, and WebSharper sitelets—and for different mobile platforms such as Android and Windows Phone. Some of these templates create single-project solutions, most notably offline sitelet projects such as the HTML Site project (see the section on offline vs. online sitelets later in this chapter). Other templates are multi-project and integrate onto standard ASP.NET web projects. For instance, the ASP.NET template creates two projects: an F# library project that contains WebSharper application code, and a web application project that exposes WebSharper site functionality via ASPX markup and includes the settings and post-processing hooks to make compiling, running, and deploying a pleasant experience. Finally, some templates come in two flavors; next to an empty application template you can find a matching sample application template as well. These make it easy to experiment with the different development approaches, such as using plain ASP.NET, MVC, or WebSharper sitelets.

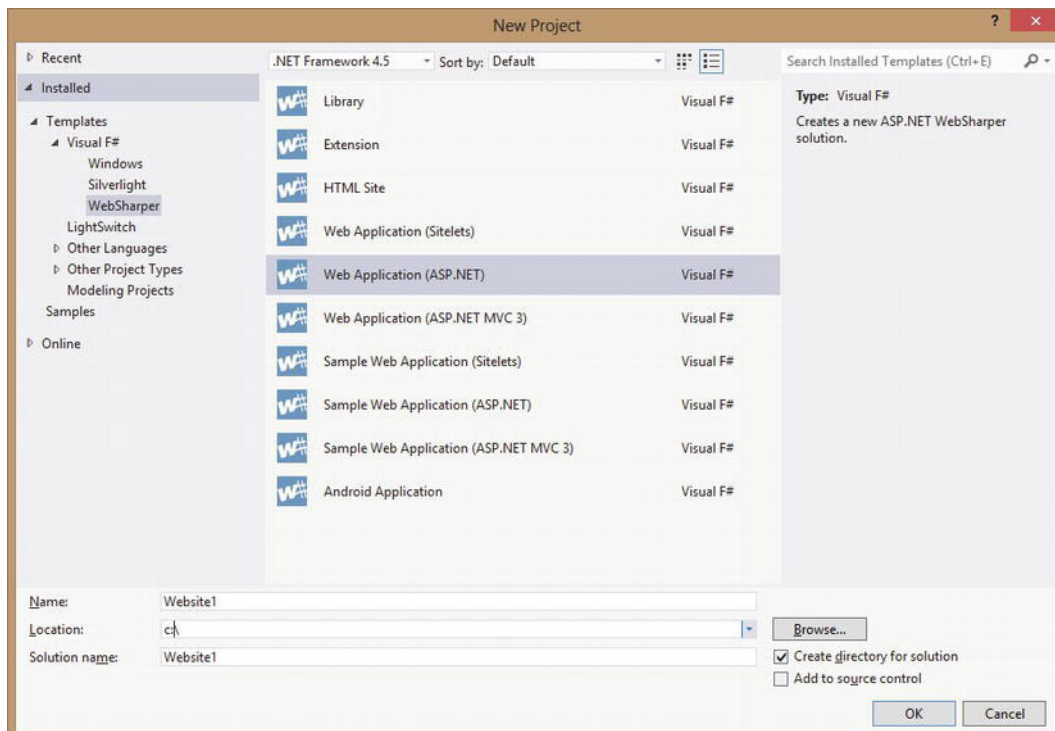

Figure 14-1. WebSharper Project Templates in Visual Studio 2010

## WebSharper Pagelets

Handling user input in ASP.NET applications involves declaring server-side controls that are rendered to HTML to take input from the end user, and defining various event handlers to handle that input. You can



add validators by declaring further server-side controls and connecting them with the controls they're to validate against. Similarly, the ASP.NET controls defined in ASPX markup are paired with their event handlers either by a predefined naming convention or by connecting them via strings in the markup.

These examples of loose coupling between the various ASP.NET components easily lead to problems when you need to code more complex web applications. Furthermore, the server-centric view requires that all components be rendered to code on the server side, which then executes to produce HTML with any submission/processing event delegated to the server again, leaving little opportunity to customize interaction on the client side.

WebSharper takes a fundamentally different approach and views web applications primarily from a client-based perspective. Client-side functionality in WebSharper applications are made up of pagelets: annotated F# code that is automatically translated to JavaScript to run on the client on demand. You can combine pagelets to form larger pagelets; and you can develop full web pages and even entire web sites as a single pagelet. Pagelets that create DOM nodes can be exposed as ASP.NET server controls and composed into ASPX markup seamlessly as you will see shortly.

Consider the following simple example:

```
namespace Website

open IntelliFactory.WebSharper
open IntelliFactory.WebSharper.Html

[<JavaScript>]
let HelloWorld () =
    let welcome = P [Text "Welcome"]
    Div [
        welcome
        Input [Attr.Type "Button"; Attr.Value "Click me!"]
        |>! OnClick (fun e args ->
            welcome.Text <- "Hello, world!")
    ]
```

Here, `HelloWorld` defines a pagelet that returns a DOM node: a `DIV` tag with two child nodes. The first child node is a paragraph containing `welcome` text, and the second is an HTML button with “Click me!” as its title. The key thing to note here is the use of the `[<JavaScript>]` attribute, which defines a particular code element to be available in JavaScript and thus on the client side. The button's `click` event handler is attached using `OnClick`, a shorthand function for `Events.OnClick`. Additional client-side HTML combinators are available in the `IntelliFactory.WebSharper.Html` namespace. These are not to be confused with their server-side HTML combinator equivalents in `IntelliFactory.Html`, as you will see shortly in the next sections describing WebSharper sitelets. Each combinator takes a sequence of DOM nodes or a sequence of attributes. If both are required, you can use the `-<` combinator, such as:

```
Div [Attr.Class "your-css-class"] -< [ ... ]
```

Your pagelets can be embedded into ASP.NET markup directly, provided that you wrap them into ASP.NET server-side controls:

```
type MyControl() =
    inherit Web.Control()

    [<JavaScript>]
    override this.Body = HelloWorld () :> _
```

Here, the `IntelliFactory.WebSharper.Web.Control` type you are inheriting from is a subclass of `System.Web.UI.Control`, and it includes a `Body` member that bootstraps your pagelet when it is embedded into ASP.NET markup or used in a WebSharper sitelet, as you will see in the sections below. Among others, this control type, along with the WebSharper *script manager control*, acts as a conduit between server and client-side code; it ensures that any client-side dependencies are correctly tracked and included (see the section later in this chapter on resource dependencies), and computes and injects the DOM structure into the containing page. Roughly speaking, it renders a “skeleton” DOM node into the output, which “comes alive” once its associated scripts and tracked dependencies start executing on the client.

To be able to add this WebSharper pagelet to your ASPX markup, your `web.config` file has to contain a `controls` declaration for your assembly that contains it. In the Visual Studio templates that come with WebSharper, the F# assembly that contains sitelet code (by default, called `Website.dll`) is preconfigured in `web.config` as follows:

```
<configuration>
  <system.web>
    <pages>
      <controls>
        <add tagPrefix="WebSharper"
            namespace="IntelliFactory.WebSharper.Web"
            assembly="IntelliFactory.WebSharper.Web" />
        <add tagPrefix="ws"
            namespace="Website"
            assembly="Website" />
      </controls>
    </pages>
  </system.web>
</configuration>
...

```

With these set up, you can embed your `MyControl` pagelet into your ASPX markup as follows:

```
<html xmlns="http://www.w3.org/1999/xhtml">
  <head runat="server">
    <title>Your WebSharper Application</title>
    <WebSharper:ScriptManager runat="server" />
  </head>
  <body>
    <ws:MyControl runat="server"/>
  </body>
</html>

```

Note how you included the WebSharper script manager control in the `<head>` section as well. This server-side control tracks resource dependencies for all WebSharper pagelets contained in your ASPX page and injects these dependencies into the HTML content served back from the server. You can read more about WebSharper’s resource tracking and dependency handling later in this chapter.

## Calling Server Code from the Client

While you can develop fully client-based (that is, all-JavaScript) applications with WebSharper, and indeed they are a very promising breed of applications, especially considering the opportunities in the mobile space, a more likely scenario is building client-server applications, where the client is actively using services or data obtained from the server either through pulling or asynchronous calls, or being pushed to using various reactive means. The common pattern in these applications is that once a page is served, it contains client-side code that implements application logic and makes occasional calls back to the server

on demand. The general trend is to move as much functionality as possible to the client, yielding highly interactive, client-based applications that use clever client-side techniques and make occasional server calls only when they need to.

You can define server-side functionality, such as functions to fetch data from server files or databases as easily as you define client-side code. Server-side functions can be exposed as web services or defined to execute over RPC. RPC functions can be called from client-code seamlessly; the communication protocol is automatically inserted and is implemented by the WebSharper runtime as JavaScript code. The following skeleton code shows the necessary annotations:

```
module YourWebApplication =
    open IntelliFactory.WebSharper

    module Server =

        [

```

One rule of thumb: be sure to add your client and server code into separate F# modules for better readability. Mixing the two in a single module is possible, but adds an extra constraint: all your client-side bindings and pagelets must be functions, e.g., you can't have top-level client-side value bindings.

## WebSharper Sitelets

So far, you have seen how you can serve dynamic, client-side functionality wrapped in ASPNET server-side controls and embedded directly into ASPX markup. WebSharper also offers a fundamentally different way to construct web applications using sitelets. WebSharper sitelets enable you to serve content without requiring a containing ASPX page, and instead let you programmatically define entire web sites in F# in a type-safe, robust, and composable way. They also provide automatic resource tracking within pages, safe URLs (computed URLs that never go out of sync), a closed representation of the entry points to your web applications, and a whole host of other useful features.

For instance, the following defines a single-page sitelet:

```
namespace Website

module OnePageSite =
    open IntelliFactory.Html
    open IntelliFactory.WebSharper.Sitelets

    type Action = | MyPage

    module Pages =
        let MyPage =
            Content.PageContent <| fun ctx ->
```

```

    {
        Page.Default with
            Title = Some "My page"
            Body =
                [
                    H1 [Text "Hello world!"]
                ]
    }

```

```
let EntireSite = Sitelet.Content "/" Action.MyPage Pages.MyPage
```

```

type Website() =
    interface IWebsite<Action> with
        member this.Sitelet = EntireSite
        member this.Actions = []

```

Above, first, you define an Action type that contains a union case for the single page in your application. This Action type is the key to understanding sitelets: it is the type that describes the interface to the outside world by providing a discriminated union for every “entry point” in your web application. A sitelet and all of its content (for example, Pages.MyPage above) then is parameterized over a given Action type. This is reflected in the type of EntireSite, which is Sitelet<Action>.

Note how you defined the content served back on various entry points. The above sitelet serves a single entry point: “/”, e.g., the root of the application, maps it to the Action.MyPage action, and serves the content Pages.MyPage as a result. Note that both the action and the response content can be parameterized to provide flexibility in handling various request parameters. See the sections below about defining content in different shapes, and about composing sitelets into larger, more complex ones.

Once you defined your sitelet value, you can formally declare it as a web application by marking your assembly with the Sitelets.Website attribute and giving the type of your sitelet to be served as a top-level application:

```
open IntelliFactory.WebSharper
```

```
[<assembly : Sitelets.Website(typeof<OnePageSite.Website>)>]
do ()
```

An assembly with the Sitelets.Website attribute is then processed by the sitelet handler configured in your application’s web.config file, provided that you started your project based on one of the standard WebSharper sitelet project templates.

## Online vs. Offline Sitelets

You may often see references to *offline* sitelets, for instance in HTML Site projects and mobile web projects for Android or Windows Phone (see Chapter 15). An offline sitelet is a rendered form of a sitelet, containing all HTML and JavaScript code used by that sitelet. In short, you can take an offline sitelet and view it in a web browser without having to serve and generate the content by a web server.

The most fundamental examples of offline sitelets are the applications you can develop using the HTML Site project template. These applications consist of 100% client-side code without an active server component. They can make calls to web services or involve other forms of dynamism, but their content is rendered into pure HTML and JavaScript when these applications are compiled.

Offline sitelets are useful from a number of perspectives. First, the offline sitelet-based applications you develop can be served by any web container, without having to pin yourself to an ASP.NET-compatible

web server such as IIS. Second, they provide the vehicle to develop self-contained mobile applications, a topic you will learn about in Chapter 15.

Online sitelets, in contrast, involve an active server-side component that responds to client queries issued over RPC. These sitelets can also be rendered into HTML and JavaScript, and packed into native mobile applications; however, their active server-side must also be available for these applications to work properly.

## Serving Content from WebSharper Sitelets

In the example above, you constructed an HTML response using `Content.PageContent`, one of the union cases of the `IntelliFactory.WebSharper.Sitelets.Content<_>` type, a type that provides an abstraction for the content of server responses. This case is appropriate when you need to construct an ordinary HTML response, such as a web page with standard headers and content you define. To help assemble such standard HTML responses, WebSharper provides the `IntelliFactory.WebSharper.Sitelets.Page` type. This type encapsulates the basic features of an HTML page in a record type and provides a `Default` member to give a default implementation:

```
/// Represents HTML pages with embedded WebSharper controls.
type Page =
{
    Doctype : string option
    Title   : string option
    Renderer : string option -> string option -> Writer -> Writer -> HtmlTextWriter -> unit
    Head    : Element<unit> seq
    Body    : Element<Control> seq
}

static member Default =
{
    Doctype = Some "<!DOCTYPE html>"
    Title   = None
    Head    = []
    Renderer = ...
    Body    = []
}
```

As in the example in the previous section, you can use `Page.Default` and override the fields you need to, most often the `Title` and `Body` of your page. The anonymous function passed to `Content.PageContent` takes a context parameter of type `Context<Action>`, where `Action` is the same action type that your sitelet and its response contents are parameterized over. You can use this context parameter to construct context-sensitive markup, such as using information available from the request or via important functions such as `Link` or `ResolveUrl`. These and the other `Context<_>` fields are summarized in Table 14-1.

**Table 14-1.** `IntelliFactory.WebSharper.Sitelets.Context<'Action>` Record Fields

Field	Type	Description
<code>ApplicationPath</code>	<code>String</code>	The virtual application root path on the server
<code>Link</code>	<code>'Action -&gt; string</code>	Generates the URL for the given action
<code>Json</code>	<code>Core.Json.Provider</code>	The typed JSON provider for interacting with the client

Field	Type	Description
Metadata	Core.Metadata.Info	WebSharper metadata required for serializing pagelets
ResolveUrl	string -> string	Generates the URL respecting the application path
ResourceContext	Core.Resources.Context	Stores information about each page and its place in the site's structure
Request	Http.Request	Provides access to the underlying request object and its various constituents.

Often times, you may need to construct non-HTML content for a response. For these situations, you can use `Content.CustomContent`, a `Content` constructor that takes a function returning an `Http.Response` value. This type is defined as a record type that provides all the necessary tools to cater to any kind of an HTTP response:

```
//// Represents HTTP responses
type Response =
{
    Status      : Http.Status
    Headers     : Http.Header seq
    WriteBody  : System.IO.Stream -> unit
}
```

Here, `Status` is the HTTP status code returned (normally, you want to return `Http.Status.Ok`, but other often-used codes are available as well), `Headers` contains the HTTP headers returned with the response to instruct the requesting clients about treating the response in various ways, and `WriteBody` is the function responsible for writing the response from a `System.IO.Stream` value.

An example for returning content and triggering a Save As... dialog box with `myfile.zip` is:

```
Content.CustomContent <| fun ctx ->
    let cd = "attachment; filename=\"myfile.zip\""
    {
        Status = Http.Status.Ok
        Headers = [Http.Header.Custom "Content-Disposition" cd]
        WriteBody = ...
    }
```

Next to using the two `Content` constructors, `PageContent` and `CustomContent`, you can also return various standard HTTP error codes using shorthand functions in the `IntelliFactory.WebSharper.Sitelets.Content` module; these are summarized in Table 14-2.

**Table 14-2.** HTTP Error Code Functions in `IntelliFactory.WebSharper.Sitelets.Content`

Function	Type	Description
Forbidden	Content<_>	The 403 Forbidden response
NotFound	Content<_>	The 404 Not Found response
ServerError	Content<_>	The 500 Server Error response
Unauthorized	Content<_>	The 401 Unauthorized response

## Using Dynamic Templates

Next to outputting all markup programmatically, WebSharper also provides templating facilities that enable you to externalize some or all of your markup into template files. These are typically easier to work with, as your design team can provide them separately or make stylistic changes on demand without affecting the code that is embedded into these templates.

As a historic note, WebSharper included *static templating* until version 2.4. Static templates were automatically translated to F# code by a Visual Studio add-in upon editing, and provided a type safe mechanism to instantiate templates programmatically. As of the current version of WebSharper, however, static templates are no longer supported; instead you should consider using dynamic templates as outlined below.

Dynamic templates plug in directly into the server-side sitelet content infrastructure, and generate values of `Content<'T>` similarly to `Content.PageContent` and `Content.CustomContent`. The main ingredients are templates defined with a set of content holes and `Content.WithTemplate` to fill these holes with actual content. Dynamic templates are created and instantiated at runtime, without static guarantees about their structure and content. This has the obvious disadvantage that templates may be incorrect and incompatible when filled with the content that your application intends to serve, but they have the flexibility to change markup dynamically, without requiring recompilation (as opposed to the now-obsolete static templates), greatly reducing the time it takes to go through various design iterations.

To use dynamic templates, you first need to define a record type to hold the content your template will be instantiated with. For instance, the following defines a `Placeholders` type for two placeholders and a `MainTemplate` template (of type `Content.Template<Placeholders>`) defined over this placeholder type that serves a local `MyTemplate.html` file with two content holes “title” and “body” defined within (you will see shortly how) instantiated from an eventual placeholder value:

```
open System.IO
open IntelliFactory.WebSharper.Sitelets

module MySite =
    open IntelliFactory.WebSharper
    open IntelliFactory.Html

    // Your sitelet action type
    type Action =
        | Home

    module Skin =
        type Placeholders =
            {
                Title : string
                Body : list<Content.HtmlElement>
            }

        let MainTemplate =
            let path = Path.Combine(__SOURCE_DIRECTORY__, "MyTemplate.html")
            Content.Template<Placeholders>(path)
                .With("title", fun x -> x.Title)
                .With("body", fun x -> x.Body)

        let WithTemplate title body : Content<Action> =
            Content.WithTemplate MainTemplate <| fun context ->
```

```

    {
        Title = title
        Body = body context
    }

```

The last function, `Skin.WithTemplate` takes a value for a title and a list of server-side HTML elements representing the body of the page, and calls `Content.WithTemplate` to instantiate `MainTemplate` with them, returning a `Content<Action>` value representing the assembled content. You can use these content values to build sitelet pages as you saw in the earlier sections.

A quick look in the imaginary `template.html` file that you are serving reveals the main dynamic templating elements:

```

<!DOCTYPE html>
<html>
  <head>
    <title>${title}</title>
    <meta name="generator" content="websharper" data-replace="scripts" />
  </head>
  <body>
    <div data-hole="body"></div>
  </body>
</html>

```

Here, you can see the main placeholder variants that WebSharper dynamic templates support:

- A `<div>` tag called "body" defined in `data-hole` mode. This mode causes the content of the placeholder to be added underneath/inside the annotated node. The content inserted must be a list of server-side HTML elements.
- A `<meta>` tag in the `<head>` section of the document, using `data-replace` mode. This mode causes the content of the placeholder to be added in place of the annotated node, in other words, replacing it. Here, the special name "scripts" is used to instruct WebSharper to embed the tracked resources and dependencies of the page, if any. Content inserted into `data-replace` nodes must be a list of server-side HTML elements.
- A string placeholder called "title", using the special syntax `${title}`. As you may expect, content inserted into string placeholders must be strings.

As you see from the example, dynamic templates are also typed (albeit only weakly), and checking that inserted content is of the right type is done at the time the template is instantiated. Various other checks are performed at this time as well, such as checking for uninstantiated placeholders, resulting in a runtime error if things don't match up. You will see examples using dynamic templates later in this chapter and in Chapter 15.

## Embedding Client-Side Controls in Sitelet Pages

Client-side controls (pagelets) can be embedded into sitelet `Content` values directly, wrapped in a parent DOM node. Here is an example of embedding the Hello World control `MyControl` you saw earlier in this chapter into the dynamic template you defined in the previous section:

```

MySite.Skin.WithTemplate "Hello World" <| fun ctx ->
  [

```



```
    Div [new Website.MyControl()]
  ]
```

Formlets, as you will see shortly, can also be similarly embedded.

## Constructing and Combining Sitelets

Building sitelets from smaller sitelets is a fundamental operation used in nearly all sitelet-based WebSharper applications. The most basic sitelet serves a response for a GET HTTP command at a given URL, for instance in the example above:

```
let EntireSite = Sitelet.Content "/" Action.MyPage Pages.MyPage
```

This constructs a sitelet over the `Action` type, which serves `Pages.MyPage` when the root path is requested. As you saw in the previous section, you have a number of alternatives for constructing responses, including basic HTML markup, non-HTML content, and various error codes.

Another important sitelet primitive is available for constructing *protected sitelets*, e.g., sitelets whose contents are protected until a requesting user logs in and possibly some further condition holds. Building upon our running example, you can update the `Action` type for your sitelet to introduce three more action cases: one for a protected page, and one for logging in and logging out. The `Login` case also takes an optional `Action` value that will be used to redirect the user after logging in:

```
module MySite =
  open IntelliFactory.Html
  open IntelliFactory.WebSharper.Sitelets

  type Action =
    | MyPage
    | Protected
    | Login of Action option
    | Logout
```

The contents you serve for these action cases are expanded as well; here you use a new helper function `Utils.SimpleContent` to construct simple HTML content with `Login/Logout` facilities prefixed:

```
module Pages =

  /// A helper function to create a hyperlink.
  let ( => ) title href = A [HRef href] -> [Text title]

  /// A helper function to create a 'fresh' URL with a random parameter
  /// in order to make sure that browsers don't show a cached version.
  let R url =
    url + "?d=" +
      System.Uri.EscapeUriString (System.DateTime.Now.ToString())

  module Utils =

    let SimpleContent title content =
      Content.PageContent <| fun ctx ->
        { Page.Default with
          Title = Some title
          Body =
```

```

        [
            match UserSession.GetLoggedInUser() with
            | None ->
                yield "Login" => ctx.Link (Action.Login (Some Action.MyPage))
            | Some user ->
                yield "Log out ["+user+"]" => R (ctx.Link Action.Logout)
        ] @ content ctx
    }

let MyPage =
    Utils.SimpleContent "My Page" <| fun ctx ->
        [
            H1 [Text "Hello world!"]
            "Protected content" => R (ctx.Link Action.Protected)
        ]

let ProtectedPage =
    Utils.SimpleContent "Protected Page" <| fun ctx ->
        [
            H1 [Text "This is protected content!"]
            "Go back" => (ctx.Link Action.MyPage)
        ]

let LoginPage action =
    Utils.SimpleContent "Login Page" <| fun ctx ->
        let redirectUrl =
            match action with
            | None ->
                Action.MyPage
            | Some action ->
                action
            |> ctx.Link
            |> R
        [
            H1 [Text "You have been logged in magically..."]
            "Proceed further" => redirectUrl
        ]

```

Now you can build two sitelets, one for the non-protected and one for the protected parts of your application, and combine them to form the complete web application. For constructing the former, you can use the handy sitelet constructor `Sitelet.Infer`, which creates a sitelet from an `Action to Content<Action>` mapping, greatly reducing the effort necessary to define larger sitelets:

```

let NonProtected =
    Sitelet.Infer <| function
    | Action.MyPage ->
        Pages.MyPage
    | Action.Login action->
        // Log in a user as "visitor" without requiring anything
        UserSession.LoginUser "visitor"
        Pages.LoginPage action

```

```

| Action.Logout ->
  // Log out the "visitor" user and redirect to home
  UserSession.Logout ()
  Content.Redirect Action.MyPage
| Action.Protected ->
  Content.ServerError

```

The price you pay for not having to stitch together single-response `Sitelet.Content` values is losing the ability to control the URL space for your resulting sitelet, e.g., observe how `Sitelet.Infer` does away with you having to specify what URLs are matched with content. Instead, `Sitelet.Infer`, as its name suggests, infers these URLs from the names of the corresponding `Action` cases, and creates unique URLs such as `/MyPage`, `/Login/...`, `/Logout`, and `/Protected` automatically. You can also manually override the URL (without any trailing slashes) for an `Action` case by annotating it with the `CompiledName` attribute as shown in the following snippet:

```

type Action =
| [<CompiledName "home">] MyPage
| Protected
| Login of Action option
| Logout

```

This will cause the URL for `MyPage` to be `/home`. One of the many advantages of `WebSharper` sitelets is this ability to automatically manage URLs and use action values instead for referring to concrete entry points that may otherwise go out of sync as development progresses. Therefore, as a best practice, you should always use the `Link` member (see Table 14-1 above) on your `WebSharper` context to compute URLs instead of hardcoded string values.

Note that above, `NonProtected` needs to match all `Action` cases, even the protected one, for which you are returning a 500 server error response. This response would be raised if you don't provide an alternate response earlier in the request serving pipeline. To set that alternate response up, you can define a protected sitelet for handling requests to the page that you want to protect (`Pages.ProtectedPage`):

```

let Protected =
  let filter : Sitelet.Filter<Action> =
    {
      VerifyUser = fun _ -> true
      LoginRedirect = Some >> Action.Login
    }

  Sitelet.Protect filter <|
    Sitelet.Content "/protected" Action.Protected Pages.ProtectedPage

```

These lines define a new response available at `/protected`, serving the `Action.Protected` action with the content `Pages.ProtectedPage`. In addition, this response is protected with a `Sitelet.Filter` value defined over the same action space. This filter requires that the requesting user is logged in. In addition, you can impose further conditions by giving a user predicate in `VerifyUser`. In this example, no additional filtering is defined and we allow any logged in user to proceed. When the filter determines that the protected content can't be served (e.g., there is no logged in user or the `VerifyUser` predicate fails), it redirects to the action specified by `LoginRedirect`, which maps the current protected action to the one where you want to redirect to for logging in (note the use of the forward composition operator `>>` to wrap this action into an option first). In our example, `Action.Login` takes an optional `Action` parameter, making it a suitable solution to divert to the login page with a return URL.

For the above to work, you need to combine the non-protected and the protected parts of your application by “summing” the corresponding sitelets, and making sure that `Protected` appears first so that

no 500 server error response is raised by `NonProtected` when requesting the protected page. You can sum several sitelets using the `<|>` operator, or alternatively the `Sitelet.Sum` combinator:

```
let EntireSite = Protected <|> NonProtected
```

Next to `Sitelet.Content`, `Sitelet.Protected`, `<|>` and `Sitelet.Sum`, there are a number of other useful sitelet combinators in the `IntelliFactory.WebSharper.Sitelets` namespace. These are summarized in Table 14-3.

**Table 14-3.** *Sitelet Combinators in IntelliFactory.WebSharper.Sitelets*

Function	Type	Description
<code>Sitelet.Empty</code>	<code>Sitelet&lt;_&gt;</code>	An empty sitelet, yielding 404 Not Found.
<code>Sitelet.Protect</code>	<code>Filter&lt;'A&gt; -&gt; Sitelet&lt;'A&gt; -&gt; Sitelet&lt;'A&gt;</code>	Protects the given sitelet with the given filter.
<code>Sitelet.Content</code>	<code>string -&gt; 'A -&gt; Content&lt;'A&gt; -&gt; Sitelet&lt;'A&gt;</code>	Constructs a singleton sitelet that serves the given content for the given URL and action
<code>Sitelet.Map</code>	<code>('A -&gt; 'B) -&gt; ('B -&gt; 'A) -&gt; Sitelet&lt;'A&gt; -&gt; Sitelet&lt;'B&gt;</code>	Maps a sitelet over to another action type.
<code>Sitelet.Sum</code>	<code>Sitelet&lt;'A&gt; seq -&gt; Sitelet&lt;'A&gt;</code>	Combines several sitelets, with the leftmost taking precedence.
<code>Sitelet.Shift</code>	<code>string -&gt; Sitelet&lt;'A&gt; -&gt; Sitelet&lt;'A&gt;</code>	Shifts all sitelet URLs by the specified folder prefix.
<code>Sitelet.Folder</code>	<code>string -&gt; Sitelets&lt;'A&gt; seq -&gt; Sitelet&lt;'A&gt;</code>	Serves the sum of the given sitelets under the specified “folder” prefix.
<code>Sitelet.Infer</code>	<code>('A -&gt; Content&lt;'A&gt;) -&gt; Sitelet&lt;'A&gt;</code>	Constructs a sitelet with an inferred router and the given controller function.

## Sitelet Routers and Controllers

`WebSharper` sitelets provide a powerful abstraction for representing web applications as F# values. They are based on two encapsulated concepts: *routers* and *controllers*. Routers are functions responsible for mapping incoming requests to sitelet actions and linking/resolving these actions back to URLs. Ideally, these should form a bijection between requests and actions, except in the cases of non-GET requests.

Controllers are functions mapping sitelet actions to actual content. As you saw in the earlier sections, you can assemble this content in various ways and provide for standard HTML or other server responses, and error codes.

You will see an example of defining routers and controllers manually in the next section. You can also consult the `WebSharper` documentation for more examples and other utilities that `WebSharper` provides to work with routers and controllers.

## Constructing Sitelets for Handling Non-GET HTTP Commands

Often times, you may need to construct sitelets that respond to non-GET HTTP commands, for instance to implement REST interfaces. As you saw in the previous sections, `Sitelet.Infer` and `Sitelet.Content` create sitelets that respond to GET requests, and in turn they abstract away the details that would otherwise be necessary to extend their coverage to other HTTP commands. You can nonetheless tap into the underlying routers and controllers to implement coverage for non-GET scenarios.

In this section, you will walk through the steps required to develop a small application to manage a set of orders and implement a simple REST API to manage these orders. This application consists of two main pages: one for adding a new order, and one for listing all past orders. These are accessible via regular GET requests at `/create` and `/orders`, respectively. The rest of the functionality is exposed via POST/PUT/DELETE requests, to create, update, and delete orders, respectively.

To get started, you may want to create an empty sitelet-based WebSharper solution. You will be updating the `Main.fs` and the `Main.html` files within this solution for this sample. In `Main.fs`, first, you create the `Order` type that represents orders. To keep things simple, your representation will cover an item name and ordered quantity only, although extending these fields to cover a realistic set of order attributes is straightforward.

```
namespace Website

type Order =
{
    ItemName : string
    Quantity : int
}
static member Dummy() =
    { ItemName = "N/A"; Quantity = 0 }
```

Next, you implement a basic `Orders` store where orders are stored. This store provides an API to generate IDs (using a private mutable reference cell to keep track of the last ID assigned), save, update and delete orders, and find them by IDs. In a real-life application, you would want to save orders into a database or some other form of persistent storage.

```
module Orders =
    let private id = ref 0
    let Store = ref Map.empty

    let Save (id: int) (order: Order) =
        Store := (!Store).Add(id, order)

    let FindById (id: int) =
        if (!Store).ContainsKey id then
            Some <| (!Store).[id]
        else
            None

    let Delete (id: int) =
        if (!Store).ContainsKey id then
            Store := (!Store).Remove id

    let GetId () =
        id := !id + 1
        !id
```

You now can create a sitelet action type that enumerates the various entry points to your application, providing a conceptual mapping between the different functionalities and actions.

```
open IntelliFactory.WebSharper
```

```

type Action =
  | CreateOrderForm
  | CreateOrder of Order
  | DeleteOrder of int
  | GetOrder of int
  | ListOrders
  | UpdateOrder of int * Order

```

Here, `CreateOrderForm` and `ListOrders` correspond to the order creation and listing pages, whereas the other actions represent the REST API you are providing. Note that these actions carry strongly-typed `Order` values when they need to.

Your application will use dynamic templating based on the `main.html` file in the root of your web application project, and you will use the helper functions you saw in earlier sections already:

```

module Skin =
  open System.Web
  open IntelliFactory.Html
  open IntelliFactory.WebSharper.Sitelets

  let TemplateLoadFrequency = Content.Template.PerRequest

  type Page = { Body : list<Content.HtmlElement> }

  let MainTemplate =
    let path = HttpContext.Current.Server.MapPath("~/Main.html")
    Content.Template<Page>(path, TemplateLoadFrequency)
      .With("body", fun x -> x.Body)

  let WithTemplate body : Content<Action> =
    Content.WithTemplate MainTemplate <| fun context ->
      {
        Body = body context
      }

```

Note how the title placeholder was removed from the sample template to make things a tiny bit shorter. You should also modify your `Main.html` file accordingly:

```

<!DOCTYPE html>
<html>
  <head>
    <meta name="generator" content="websharper" data-replace="scripts" />
  </head>
  <body>
    <div data-hole="body" />
  </body>
</html>

```

To continue in `Main.fs`, you can build a simple formlet to gather the order information from the user. You will learn about `WebSharper` formlets in the next section, for now just observe the clarity and progressive enhancement you can apply in building this formlet.

```

module Client =
  open IntelliFactory.WebSharper.Formlet

```

```

open IntelliFactory.WebSharper.Html

[<JavaScript>]
let OrderForm orderPostUrl =
    Formlet.Yield (fun title qty -> { ItemName = title; Quantity = qty })
    <*> (Controls.Input ""
        |> Validator.IsNotEmpty "Must enter a title"
        |> Enhance.WithTextLabel "Title")
    <*> (Controls.Input ""
        |> Validator.IsInt "Must enter a valid quantity"
        |> Formlet.Map int
        |> Enhance.WithTextLabel "Quantity")
    |> Enhance.WithSubmitAndResetButtons
    |> Enhance.WithErrorSummary "Errors"
    |> Enhance.WithFormContainer
    |> Enhance.WithJsonPost
        {
            Enhance.JsonPostConfiguration.EncodingType = None
            Enhance.JsonPostConfiguration.ParameterName = "order"
            Enhance.JsonPostConfiguration.PostUrl = Some orderPostUrl
        }

type OrderFormControl(orderPostUrl: string) =
    inherit Web.Control()

    [<JavaScript>]
    override this.Body =
        Div [
            OrderForm(orderPostUrl)
        ] :> _

```

Here, the `OrderForm` function and the encapsulating `OrderFormControl` server control takes the URL to where your formlet will send a POST request with an `Order` record embedded in the request variables under the "order" parameter. This URL will be computed when you construct the various pages in your sitelet. First, let's begin with the create order page:

```

module Pages =
    open IntelliFactory.Html

    let ( => ) text url =
        A [HRef url] -< [Text text]

    let Links (ctx: Context<Action>) =
        UL [
            LI ["Home" => ctx.Link Action.ListOrders]
            LI ["New" => ctx.Link Action.CreateOrderForm]
        ]

    let CreateOrderFormPage =
        Skin.WithTemplate <| fun ctx ->
            [

```

```

    H1 [Text "Create order"]
    Links ctx
    HR []
    Div [
        new Client.OrderFormControl(
            Order.Dummy() |> Action.CreateOrder |> ctx.Link
        )
    ]
]

```

This page displays a basic menu and the order creation form. The URL passed here for creating the order is computed using `ctx.Link` and a dummy order passed to the right action. The page that lists the stored orders is equally straightforward, creating a bullet list of the orders with a link to display/get each.

```

let ListOrdersPage =
    Skin.WithTemplate <| fun ctx ->
    [
        H1 [Text "Orders"]
        Links ctx
        HR []
        UL <|
            ((!Orders.Store)
            |> Map.toList
            |> Seq.map (fun (id, order) ->
                LI [
                    A [HRef <| ctx.Link (Action.GetOrder id)] -< [
                        sprintf "#%d: %s [%d]" id order.ItemName order.Quantity
                    ]> Text
                ]
            ])
        ])
    ])

```

For retrieving a specific order, you can display it in HTML or serve it back in a more reusable format, say in JSON. Below is a function rendering JSON responses for a given order ID.

```

let GetOrder id =
    if (!Orders.Store).ContainsKey id then
        Content.CustomContent <| fun ctx ->
        {
            Http.Response.Status = Http.Status.Ok
            Http.Response.Headers = [Http.Header.Custom "Content-type" "application/
json"]
            Http.Response.WriteBody = fun stream ->
                use writer = new System.IO.StreamWriter(stream)
                let order = (!Orders.Store).[id]
                let encoder = Web.Shared.Json.GetEncoder(typeof<Order>)
                order
                |> encoder.Encode
                |> Web.Shared.Json.Pack
                |> Core.Json.Stringify
                |> writer.Write

```



```

        writer.Close()
    }
else
    Content.NotFound

```

With the necessary response content functions defined, you can now build your sitelet to represent the entire web application:

```

module MySite =
    open IntelliFactory.WebSharper.Sitelets
    open UrlHelpers

    let (|PATH|_) (uri: System.Uri) = Some <| uri.LocalPath

    let MySitelet =
        Sitelet.Sum [
            Sitelet.Content "/create" Action.CreateOrderForm Pages.CreateOrderFormPage
            Sitelet.Content "/orders" Action.ListOrders Pages.ListOrdersPage
        ]
    <|>
    {
        Router = Sitelets.Router.New
        <| function
            | POST (values, PATH @"/order") ->
                try
                    let decoder = Web.Shared.Json.GetDecoder<Order>()
                    let order =
                        values
                        |> Map.ofList
                        |> fun map -> map.[ "order" ]
                        |> Core.Json.Parse
                        |> decoder.Decode
                    Some <| Action.CreateOrder order
                with
                    | _ ->
                        None
            | GET (values, SPLIT_BY '/' ["order"; INT id]) ->
                Some <| Action.GetOrder id
            | PUT (values, SPLIT_BY '/' ["order"; INT id]) ->
                try
                    let decoder = Web.Shared.Json.GetDecoder<Order>()
                    let order =
                        values
                        |> Map.ofList
                        |> fun map -> map.[ "order" ]
                        |> Core.Json.Parse
                        |> decoder.Decode
                    Some <| Action.UpdateOrder(id, order)
                with
                    | _ ->
                        None
    }

```

```

        | DELETE (values, SPLIT_BY '/' ["order"; INT id]) ->
            Some <| Action.DeleteOrder id
        | _ ->
            None
    <| function
        | Action.CreateOrder order ->
            Some <| System.Uri(@"/order", System.UriKind.Relative)
        | Action.DeleteOrder id
        | Action.GetOrder id
        | Action.UpdateOrder (id, _) ->
            Some <| System.Uri(sprintf @"/order/%d" id, System.UriKind.Relative)
        | _ ->
            None

Controller =
{
    Handle = function
        | Action.CreateOrder order ->
            Orders.Save (Orders.GetId()) order
            Content.Redirect Action.ListOrders
        | Action.DeleteOrder id ->
            Orders.Delete id
            Content.Redirect Action.ListOrders
        | Action.GetOrder id ->
            Pages.GetOrder id
        | Action.UpdateOrder (id, order) ->
            Orders.Save id order
            Content.Redirect Action.ListOrders
        | _ ->
            failwith "unmatched"
    }
}

```

```

type MyWebsite() =
    interface IWebsite<Action> with
        member this.Sitelet = MySitelet

```

member this.Actions = []The above code implements a router and controller manually. The router is created using `Sitelets.Router.New` and giving two functions to map from requests to actions and back. Note how you can use the various URL helpers from the `Sitelets.UrlHelpers` module to differentiate between the different HTTP commands and to parse out parts of the URLs in a type-safe manner. Consider, for instance, handling the GET request to an order, where `id` is an integer:

```

    | GET (values, SPLIT_BY '/' ["order"; INT id]) ->
        Some <| Action.GetOrder id

```

For the POST and PUT requests, next to the ID passed in the URL, we also expect a JSON representation of an `Order` value among the values passed in the request. This value is then extracted and converted to an `Order` instance using the built-in `WebSharper` JSON decoder.

The controller is less interesting; it simply maps actions to server responses. For instance, the `CreateOrder` action writes the given order into the store and redirects the user to the order listing page.

The final piece left is to mark this application as a website on the assembly:

```
[<assembly: Website(typeof<MySite.MyWebsite>)>]
do ()
```

Figure 14-2 shows the application in action: the create order and the list orders pages. When requesting a given order you get a JSON response, for instance:

```
{"$TYPES": [], "$DATA": {"$V": {"ItemName": "Windows Server 2012", "Quantity": 5}}}
```

This contains some additional fields embedded into the JSON representation that WebSharper uses to facilitate communication and type-safe conversation of values between the client and the server. You may also use another .NET JSON library to produce clean, neutral representations if you wish.

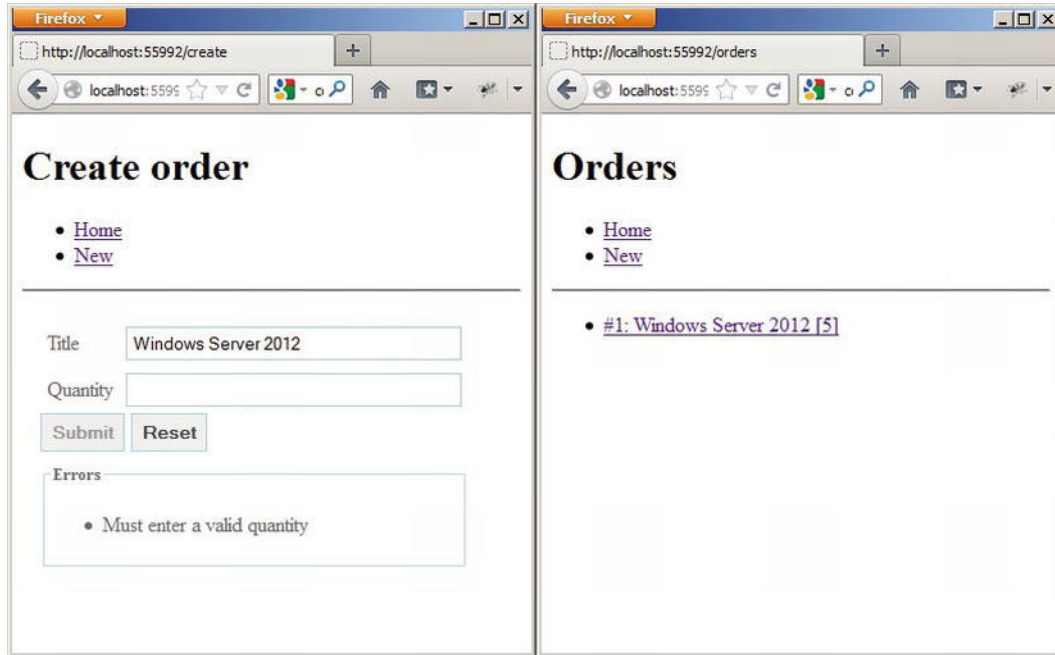

Figure 14-2. The Create Order and the List Orders Pages

## WebSharper Formlets

Nearly all web pages need to take user input in one way or another. For example, the user may click buttons or links, or enter values in a web form. Furthermore, web forms typically impose various limitations for the values entered; for instance, many fields are required fields and must be supplied a value, or certain fields such as date fields require values in a specific format, or else, others expect values that contain alpha, numeric and/or special characters only, and the list goes on.

WebSharper formlets provide an elegant, type-safe, and robust way to build web forms and encapsulate the structural make-up, the validations involved, and the layout and other presentation details as a single F# value. They're composable building blocks that can be nested, enhanced, and customized to an arbitrary complexity.

The `IntelliFactory.WebSharper.Formlet` namespace contains various formlet controls and enhancements that you can apply to them, along with important formlet combinators such as `Formlet.Run`, which renders a formlet into a DOM node. A simple example is a text-box formlet that takes a string input from the user:

```

namespace Website

open IntelliFactory.WebSharper

module FormletSnippets =
    open IntelliFactory.WebSharper.Formlet
    open IntelliFactory.WebSharper.Html

    [<JavaScript>]
    let Snippet1 = Controls.Input "initial value"

```

You can test this and other formlets quickly by writing a short wrapper function that takes a render function that translates values to DOM nodes and a formlet that supplies those values:

```

[<JavaScript>]
let RunInBlock title f formlet =
    let output = Div []
    formlet
    |> Formlet.Run (fun res ->
        let elem = f res
        output -< [ elem ] |> ignore)
    |> fun form ->
        Div [Attr.Style "float:left;margin-right:20px;width:300px;min-height:200px;" ] -< [
            H5 [Text title]
            Div [form]
            output
        ]

```

Another helper function takes simple string formlets and echoes what has been accepted by those formlets:

```

[<JavaScript>]
let RunSnippet title formlet =
    formlet
    |> RunInBlock title (fun s ->
        Div [
            P ["You entered: " + s |> Text]
        ])

```

RunSnippet returns a client-side Element value that you can wrap in an ASP.NET server control:

```

module Formlets =
    open FormletSnippets
    open IntelliFactory.WebSharper.Html

    type Snippet() =
        inherit Web.Control()

        [<JavaScript>]
        override this.Body = RunSnippet "Snippet1" Snippet1 :> _

```

Adding this ASP.NET server control to an ASPX markup displays a text box to write text into and an empty echo message. Each time you press a key, an event is triggered, and the formlet enters an accepting state; subsequently, it displays a new echo message that is appended to the previous ones. Note that this formlet is in an accepting state even without typing anything into it.

To remove the initial empty echo message, that is to cause the formlet not to enter an accepting state initially, and impose further conditions for its acceptance, you can add various validators that “block” until a certain condition holds. For instance, you can use `Validator.Is` to inspect its current value and reject or accept based on any criteria you define. For instance, here is a basic input formlet, enhanced with a validator that doesn’t accept values with fewer than three characters:

```
[<JavaScript>]
let Snippet1a =
    Formlet.Yield (fun name -> name)
    <*> (Controls.Input ""
        |> Validator.Is (fun s -> s.Length > 3) "Enter a valid name")
```

This is a slightly more elaborate version of the input formlet, enhanced with a general validator and wrapped in a `Formlet.Yield` combinator. This function defines how the values collected in the formlet are combined and returned from the formlet and comes in handy for composing larger formlets that contain multiple input fields. The general form of `Formlet.Yield` looks like this:

```
Formlet.Yield (fun v1 ... vn -> <compose into a single return value>)
<*> formlet1
<*> ...
<*> formletn
```

Here, `v1`, ..., `vn` correspond to the return values of `formlet1`, ..., `formletn`, respectively. Note how these formlets are combined using the `<*>` formlet operator. Combining two formlets yields another formlet with the visuals of the combined formlets laid out vertically. You can learn about changing formlet layout later in this section.

Now that you are familiar with constructing basic formlets with validators and combining them to build larger formlets, let’s look at a few more snippets that apply progressive enhancement to your basic input formlet. Table 14-4 contains the most often used enhancements.

**Table 14-4.** *Formlet Enhancement Functions in `IntelliFactory.WebSharper.Formlet.Enhance`*

Function	Type	Description
<code>WithCssClass</code>	<code>string -&gt; Formlet&lt;'T&gt; -&gt; Formlet&lt;'T&gt;</code>	Enhances the given formlet with a CSS class.
<code>WithCustomFormContainer</code>	<code>FormContainerConfiguration -&gt; Formlet&lt;'T&gt; -&gt; Formlet&lt;'T&gt;</code>	Enhances the given formlet with a custom form container.
<code>WithCustomResetButton</code>	<code>FormButtonConfiguration -&gt; Formlet&lt;'T&gt;</code>	Enhances the given formlet with a custom reset button.
<code>WithCustomSubmitAndResetButtons</code>	<code>FormButtonConfiguration -&gt; FormButtonConfiguration -&gt; Formlet&lt;'T&gt; -&gt; Formlet&lt;'T&gt;</code>	Enhances the given formlet with custom submit and reset buttons.
<code>WithCustomSubmitButton</code>	<code>FormButtonConfiguration -&gt; Formlet&lt;'T&gt; -&gt; Formlet&lt;'T&gt;</code>	Enhances the given formlet with a custom submit button.
<code>WithCustomValidationFrame</code>	<code>ValidationFrameConfiguration -&gt; Formlet&lt;'T&gt; -&gt; Formlet&lt;'T&gt;</code>	Enhances the given formlet with a custom validation frame.

Function	Type	Description
WithCustomValidationIcon	ValidationIconConfiguration -> Formlet<'T> -> Formlet<'T>	Enhances the given formlet with a custom validation icon.
WithErrorFormlet	(string list -> Formlet<'U>) -> Formlet<'T> -> Formlet<'T>	Enhances the given formlet with a formlet for displaying error messages.
WithErrorSummary	string -> Formlet<'T> -> Formlet<'T>	Enhances the given formlet with an error summary that contains a list of error messages when in a failing state.
WithFormContainer	Formlet<'T> -> Formlet<'T>	Enhances the given formlet with a standard form container.
WithLabel	(unit -> Html.Element) -> Formlet<'T> -> Formlet<'T>	Enhances the given formlet with a label generated by the first argument.
WithLabelAbove	Formlet<'T> -> Formlet<'T>	Enhances the given formlet by displaying labels above components.
WithLabelAndInfo	string -> string -> Formlet<'T> -> Formlet<'T>	Enhances the given formlet by a text label and an info tooltip.
WithLabelConfiguration	Layout.LabelConfiguration -> Formlet<'T> -> Formlet<'T>	Enhances the given formlet by a custom label.
WithLabelLeft	Formlet<'T> -> Formlet<'T>	Enhances the given formlet by displaying labels on the left.
WithLegend	string -> Formlet<'T> -> Formlet<'T>	Enhances the given formlet with a legend box.
WithResetButton	Formlet<'T> -> Formlet<'T>	Enhances the given formlet with a basic reset button.
WithResetFormlet	Formlet<'T> -> Formlet<'U> -> Formlet<'T>	Enhances the first formlet with reset capabilities defined by the second.
WithResetAction	(unit -> bool) -> Formlet<'T> -> Formlet<'T>	Adds a reset predicate that controls the resetting behavior of the containing formlet.
WithRowConfiguration	Layout.FormRowConfiguration -> Formlet<'T> -> Formlet<'T>	Enhances the given formlet with a custom row configuration.
WithSubmitAndReset	Formlet<'T> -> ((unit -> unit) -> Result<'T> -> Formlet<'U>) -> Formlet<'U>	Enhances the given formlet with the given submitting formlet and reset function.
WithSubmitAndResetButtons	Formlet<'T> -> Formlet<'T>	Enhances the given formlet with basic submit and reset buttons.
WithSubmitButton	Formlet<'T> -> Formlet<'T>	Enhances the given formlet with a basic submit button.
WithSubmitFormlet	Formlet<'T> -> (Result<'T> -> Formlet<unit>) -> Formlet<'T>	Enhances the given formlet by applying a submitting formlet.
WithTextLabel	string -> Formlet<'T> -> Formlet<'T>	Enhances the given formlet by a text label.

Function	Type	Description
WithValidationIcon	Formlet<'T> -> Formlet<'T>	Enhances the given formlet with a basic validation icon.
WithValidationFrame	Formlet<'T> -> Formlet<'T>	Enhances the given formlet with a standard validation frame.
CustomMany	ManyConfiguration -> Formlet<'T> -> Formlet<list<'T>>	Creates a custom formlet for inputting a list of values using the given formlet.
Many	Formlet<'T> -> Formlet<list<'T>>	Creates a formlet for inputting a list of values using the given formlet.
WithJsonPost	JsonPostConfiguration -> Formlet<'T> -> Html.Element	Wraps the given formlet in an Element, and submits the values entered in a POST to a given URL.

Many features of the WebSharper formlet library are driven by pure CSS, and the necessary CSS resources are automatically included in your page when you use formlet form containers by applying the `Enhance.WithFormContainer` function. This applies a clean visual theme to your buttons and input fields, and lights up the validation and informational features. For instance, here is a basic input control wrapped in a form container with a validator that accepts any non-empty string (so it blocks on empty input):

```
[<JavaScript>]
let Snippet1b =
    Formlet.Yield (fun name -> name)
    <*> (Controls.Input ""
        |> Validator.IsNotEmpty "Enter a valid name"
        |> Enhance.WithFormContainer)
```

You can also cause this formlet not to accept until a submit button is pressed. In addition, you can supply a reset button that resets the formlet to its original state. This example adds both:

```
[<JavaScript>]
let Snippet1c =
    Formlet.Yield (fun name -> name)
    <*> (Controls.Input ""
        |> Validator.IsNotEmpty "Enter a valid name"
        |> Enhance.WithFormContainer
        |> Enhance.WithSubmitAndResetButtons)
```

The accepting status of this formlet and any validation error messages can be revealed to the user via a validation icon or an error summary enhancement. For these to work properly, your formlet needs to be in a form container. You can add a validation icon and/or a validation error summary as follows:

```
[<JavaScript>]
let Snippet1d =
    Formlet.Yield (fun name -> name)
    <*> (Controls.Input ""
        |> Validator.IsNotEmpty "Enter a valid name"
        |> Enhance.WithValidationIcon
        |> Enhance.WithErrorSummary "Errors")
```

```

    |> Enhance.WithSubmitAndResetButtons
    |> Enhance.WithFormContainer)

```

Adding a label for the input control is yet another enhancement:

```

[<JavaScript>]
let Snippet1e =
    Formlet.Yield (fun name -> name)
    <*> (Controls.Input ""
        |> Validator.IsNotEmpty "Enter a valid name"
        |> Enhance.WithValidationIcon
        |> Enhance.WithTextLabel "Name"
        |> Enhance.WithSubmitAndResetButtons
        |> Enhance.WithFormContainer)

```

And finally, you can add an information icon before the label:

```

[<JavaScript>]
let Snippet1f =
    Formlet.Yield (fun name -> name)
    <*> (Controls.Input ""
        |> Validator.IsNotEmpty "Enter a valid name"
        |> Enhance.WithValidationIcon
        |> Enhance.WithLabelAndInfo "Name" "Enter your name"
        |> Enhance.WithSubmitAndResetButtons
        |> Enhance.WithFormContainer)

```

You can quickly test these formlets side-by-side by defining ASP.NET server-side controls for each and embed them into your ASPX markup as you did before. You can also test them quickly by embedding them into a sitelet page. Assuming you have the above snippets in a Formlets module, you can add in the same module a new pagelet to display them all:

```

module Formlets =
    open FormletSnippets
    open IntelliFactory.WebSharper.Html

    type Snippet() =
        inherit Web.Control()

        [<JavaScript>]
        override this.Body = RunSnippet "Snippet1" Snippet1 :> _

    type Snippets() =
        inherit Web.Control()

        [<JavaScript>]
        override this.Body =
            Div [
                RunSnippet "Snippet1" Snippet1
                RunSnippet "Snippet1a" Snippet1a
                RunSnippet "Snippet1b" Snippet1b
                RunSnippet "Snippet1c" Snippet1c

```



```

        RunSnippet "Snippet1d" Snippet1d
        RunSnippet "Snippet1e" Snippet1e
        RunSnippet "Snippet1f" Snippet1f
    ] :> _

```

Your sitelet can then serve this pagelet in a single-page, single-action sitelet under the root path:

```

module VariousFormletSnippets =
    open IntelliFactory.Html
    open IntelliFactory.WebSharper.Sitelets

    type Action = | Home

    module Pages =
        let SnippetsPage =
            Content.PageContent <| fun ctx ->
                { Page.Default with
                    Title = Some "Formlet snippets"
                    Body =
                        [
                            H1 [Text "Snippets"]
                            Div [new Formlets.Snippets()]
                        ]
                }

        let EntireSite =
            Sitelet.Content "/" Action.Home Pages.SnippetsPage

    type Website() =
        interface IWebsite<Action> with
            member this.Sitelet = EntireSite
            member this.Actions = []

[<assembly : Sitelets.Website(typeof<VariousFormletSnippets.Website>)>]
do ()

```

The formlets from this sitelet are shown in Figure 14-3. Although these examples contain a single input field, you can also create input formlets with multiple fields as shown in the following example:

```

[<JavaScript>]
let input (label : string) (err : string) =
    Controls.Input ""
    |> Validator.IsNotEmpty err
    |> Enhance.WithValidationIcon
    |> Enhance.WithTextLabel label

[<JavaScript>]
let inputInt (label : string) (err : string) =
    Controls.Input ""
    |> Validator.IsInt err
    |> Enhance.WithValidationIcon
    |> Enhance.WithTextLabel label

```

```
[<JavaScript>]
let Snippet2 : Formlet<string * int> =
  Formlet.Yield (fun name age -> name, age |> int)
  <*> input "Name" "Please enter your name"
  <*> inputInt "Age" "Please enter a valid age"
  |> Enhance.WithSubmitAndResetButtons
  |> Enhance.WithFormContainer
```

Note how this formlet returns a string-int pair for the name and age obtained from the user, in essence providing a type-safe and robust way to collect and handle the input values.

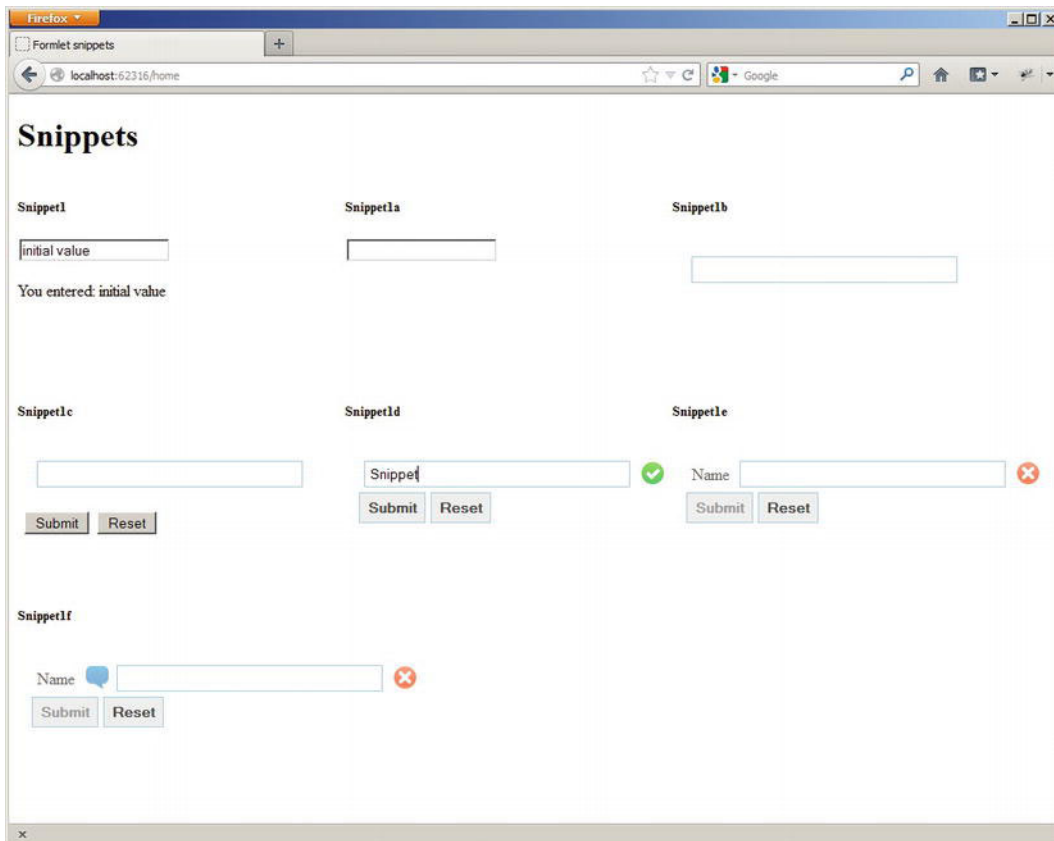

Figure 14-3. Various Formlet Snippets

Another useful formlet combinator is `Enhance.Many`. It gives you the ability to collect a list of values based on a formlet that collects a single value:

```
[<JavaScript>]
let Snippet3a =
  Formlet.Yield (fun name age -> name, age |> int)
  <*> input "Name" "Please enter your name"
  <*> inputInt "Age" "Please enter a valid age"
```

```

|> Enhance.WithLegend "Person"
|> Enhance.WithTextLabel "Person"
|> Enhance.Many
|> Enhance.WithLegend "People"
|> Enhance.WithSubmitAndResetButtons
|> Enhance.WithFormContainer

```

## Dependent Formlets and Flowlets

Often, web forms need more elaborate considerations. For instance, part of a web form may depend on a value entered in another part. You can express these dependencies using *dependent formlets*, which you can create most conveniently using the `Formlet.Do` computation expression builder. As plain formlets, dependent formlets are also first-class values and further encode linear dependencies between the various form parts. Consider the following simple example in which the name and age are obtained one after the other, requiring that a name is entered before the input field for the age is displayed:

```

[<JavaScript>]
let Snippet4 =
    Formlet.Do {
        let! name = input "Name" "Please enter your name"
        let! age = inputInt "Age" "Please enter a valid age"
        return name, age |> int
    }
|> Enhance.WithSubmitAndResetButtons
|> Enhance.WithFormContainer

```

The `IntelliFactory.WebSharper.Formlet` namespace provides additional combinators you can use to express nonlinear dependencies and build complex user interface interactions and forms.

Similar to dependent formlets, *flowlets* provide a slightly different visual experience and enable you to serve various formlets as a sequence of steps, collecting and accumulating the composite result of the entire flowlet. The following example dresses up each primitive formlet step in a form container with reset and submit buttons:

```

[<JavaScript>]
let Snippet4b =
    Formlet.Do {
        let! name = input "Name" "Please enter your name"
            |> Enhance.WithSubmitAndResetButtons
            |> Enhance.WithFormContainer
        let! age = inputInt "Age" "Please enter a valid age"
            |> Enhance.WithSubmitAndResetButtons
            |> Enhance.WithFormContainer
        return name, age |> int
    }
|> Formlet.Flowlet

```

## Automated Resource Tracking and Handling

Pagelets often need to define their own resource dependencies, such as style sheets, JavaScript code, and other artifacts that they need to work properly. These dependencies are automatically referenced and included by the `WebSharper` script manager when those pagelets are used in an ASPX or sitelet page. For

instance, the formlet examples in the preceding section came with a dependency on the main formlet style sheet provided by WebSharper (along with additional skins), giving the appearance shown in Figure 14-3.

Resources can be defined and tagged on various parts of your code, most typically on functions or modules when binding various JavaScript libraries, and once those parts are referenced, the corresponding resources are included in the consuming page. From this automation point of view, resource annotations serve to define anchors to external artifacts using generated HTML markup, inserted into the <head> section of the containing page.

The most low-level implementation of a resource thus renders this HTML markup:

```
namespace Website

open IntelliFactory.WebSharper
open IntelliFactory.WebSharper.Core

// Put "my.js" in the root of the web project.
type MyResource() =
    interface Resources.IResource with
        member this.Render ctx writer =
            writer.WriteLine "<script src='my.js' type='javascript'></script>"
```

You rarely need to use custom rendered resources. Instead, to define a resource pointing to a CSS or JavaScript file, you can simply use the `BaseResource` class. This class has two constructors: one that you can use to define a resource embedded into the assembly, and another that can address an external resource relative to an absolute base URL (in the first argument). An example for an embedded resource, here, be sure to mark `my.js` as an embedded resource in your solution:

```
[<assembly:System.Web.UI.WebResource("my.js", "text/javascript")>]
do ()
```

```
type MyEmbeddedResource() =
    inherit Resources.BaseResource("my.js")
```

Using the multi-argument constructor:

```
type MyExternalResource() =
    inherit Resources.BaseResource(@"http://your.net", "lib.js", "style.css")
```

The advantage of using `Resources.BaseResource` is that you can avoid having to render HTML in your resource declaration. Instead, `Resources.BaseResource` is smart enough to tell apart JavaScript and CSS artifacts, and outputs the right markup for each.

Once you have defined the resources you need, you can annotate them on any type (or module) or any static member using the `Require` attribute, specifying the type of the resource that is to be pinned to the given code unit.

```
[<Require(typeof<MyExternalResource>)>]
type Hello = ..
```

From this point, any use of the `Hello` type will trigger a dependency defined in `MyExternalResource`.

## Using Third-Party JavaScript Libraries

One of WebSharper's great strengths is its ability to use any JavaScript library in client-side F# code, freeing you from having to develop untyped JavaScript code as a separate code base. To talk to these JavaScript libraries in F#, you need a WebSharper *extension* for each library. At the time of writing, WebSharper comes

with a number of extensions to various JavaScript libraries, including jQuery, Google Maps and Visualization, Yahoo UI, jQuery UI, jQuery Mobile, and many others. Some of these come with the main WebSharper installer (for instance, jQuery and the HTML5 extensions), and some you have to download from the WebSharper site (<http://websharper.com>) separately.

You can also develop WebSharper extensions to your own or third-party JavaScript libraries. Many JavaScript libraries use loosely typed constructs, such as functions that take a variable number and type of arguments, and return objects with different structures. To bind these libraries, you often need to resort to a low-level, weakly-typed extension often referred to as a *native extension*, and build a derived, more strongly-typed and safer F# abstraction around it as second library.

WebSharper extensions are defined in F# using embedded domain-specific language syntax and are processed through the WebSharper Interface Generator (WIG) tool. These definitions are meant to be terse and compact, reiterating the underlying JavaScript API in F# using a set of convenient notations and operators.

You can quickly get started with a new extension by using the Extension project template that comes with the standard WebSharper installer. This creates a new F# project with a single source file `Main.fs` that contains two important pieces: first, a `Definition` module that uses the WIG syntax to define various types, interfaces, classes, and members that form an “assembly,” which is a code unit that represents a JavaScript library as a single F# value, and second, a `Main` module that triggers the generation of the extension from this “assembly” value. The generation of the extension involves outputting source code decorated with `Inline` attributes, and compiling it to a .NET assembly that contains the extension. You could also write the code that WIG generates by hand, but you would quickly start to appreciate the amount of effort WIG saves you by automating many of the abstraction chores and common JavaScript usage patterns.

The full WIG language definition is outside the scope of this chapter, and you should consult the WebSharper documentation for more details. You will see a short example of using WIG in Chapter 15 for describing a small portion of the Facebook API to be used in mobile web application.

## Working with .NET Proxies

WebSharper enables you to use F# in your client-side coding and gives you nearly the entire F# language to develop client-side code, including powerful language features such as pattern matching, active patterns, discriminated unions and records, classes, interfaces, exceptions, and asynchronous computations, among others. This is coupled with the ability to use a large part of the F# core libraries and standard .NET namespaces in client-side code, without having to worry about how to map them to JavaScript. The mechanism to enable this seamless translation experience is *proxying*, a fundamental WebSharper concept that you should be familiar with, as you may need to add proxies yourself to your own or third-party libraries to extend translation coverage.

WebSharper proxies provide a JavaScript interpretation for a .NET type. This proxy type is annotated with the `Proxy` attribute, giving the type of the underlying target .NET type for which the proxy is provided. Here is a small, partial example to proxy the standard F#/.NET `int` type:

```
open IntelliFactory.WebSharper

[<Proxy(typeof<System.Int32>>)]
type private Int32 =

    static member MaxValue with [Inline "2147483647"] get () = 0
    static member MinValue with [Inline "-2147483648"] get () = 0

    [Inline "parseInt($s)"]
    static member Parse(s: string) = X<int>
```

Note how the three static members use the `InLine` attribute to express their counterparts in JavaScript, and these inline expressions will be evaluated and used in the translation of client-side code instead of invoking the right-hand side of each member. The above snippet also demonstrates a subtle point in how proxies (and JavaScript stubs as well) are defined, e.g., what you supply as the `.NET` implementation for each member. You can apply the following techniques in defining your JavaScript mapping for proxying a `.NET` type or stubbing JavaScript code:

- You should never call proxies directly. Remember, they are only used in translating `.NET` types to JavaScript. Hence, you can leave their implementation empty (say, by constructing the default value of the return type) or yield an exception. For this, you can use the `X< 'T>` construct as in the `Parse` member above. Yielding an exception is a preferred approach, so in case you accidentally call proxy members, you are notified runtime.
- Since stubbed (that is, inlined) code is designed to be called, you need to take care how you call these stubbed functions and members. Calling from client code is the intended behavior; here, `WebSharper` will evaluate and use the attached inline expressions and ignore the `.NET` implementation. However, if you also want to make your stubbed functions available for server-side use (a rare, but useful device when used in a controlled fashion), you should attach a semantically correct `.NET` implementation.

## Summary

In this chapter, you've seen how to use F# to perform a range of web programming tasks. You started by using sockets and TCP/IP to implement a web server and other TCP-based services directly, an example of a system or web network programming task. In the larger part of the chapter, you have looked at using `WebSharper`, the main F# web framework to develop client-based applications that incorporate significant client-side scripting, and authored them in pure F# code. You looked at `WebSharper` pagelets, learned how you can use them to embed client-side functionality into your pages, and learned about `WebSharper` sitelets to represent entire web applications as server-side F# values in a type-safe and composable manner. You also saw how to build user interfaces and web forms in a declarative fashion, employing progressive enhancement techniques and represent these client-side user interfaces as strongly-typed F# values that can be combined and nested to an arbitrary complexity. As well, you saw a number of powerful formlet combinators that yield a massive productivity factor when it comes to building more complex web forms, such as accepting a list of user inputs, expressing dependencies within form elements, and applying different visual rendering techniques and validation functions.

You also became familiar with `WebSharper`'s extensibility framework: how you can develop `WebSharper` extensions to any third-party JavaScript library, or proxies to extend the `.NET` to JavaScript translation coverage. With these techniques, you can leverage a massive paradigm shift towards building more client-oriented, reactive applications with less code, while enjoying more robustness and type safety.

## CHAPTER 15



# Building Mobile Web Applications

Mobile applications are changing the way people interact with software. With the abundance of mobile devices such as smart phones and tablets, developing mobile applications and delivering content to mobile devices requires learning new skills and technologies. This chapter examines how you can build mobile web and native applications in F# using WebSharper. The topics covered are:

- Why web-based mobile applications are becoming increasingly important
- How you can use feature detection and polyfilling libraries in your applications to work around mobile browser limitations and missing features
- How you can serve mobile web content from your WebSharper applications
- How you can develop WebSharper applications for iOS that use platform-specific markup to access unique features such as multi-touch events
- How you can develop WebSharper applications that use the Facebook API, parts of which you bind manually using a WebSharper Extension project
- How you can use WebSharper Mobile to create native Android and Windows Phone packages for your WebSharper applications
- How you can integrate mobile formlets and Bing Maps in a WebSharper application

## Web-based vs. Native Mobile Applications

Mobile applications are designed to run on mobile devices and to utilize their additional capabilities such as GPS positioning, camera, and touch screen; more technically, they rely on the executing mobile operating system to provide access to mobile capabilities found on the device. When mobile devices first appeared, various vendors produced operating systems for them, each providing a unique user experience and capabilities, and with that, a unique way to develop applications for these platforms.

Native applications are those designed to run specifically on a given platform (or even a specific hardware device), and depend on the exact capabilities that are provided on that platform by its execution environment. Typically, a native application needs heavy adaptation or even an entire rewrite in order to run on another platform. For instance, many iPhone or iPad applications are developed in Apple's own programming language, using vendor-specific libraries and development environments. The same holds for native Android, Windows Phone, Symbian, and other applications.

To add to the diverse mobile operating system landscape, each platform comes with its own *application store*, giving end-users a one-stop shop for new applications and their updates. While the

existence of application stores has resulted in a massive explosion in the number of mobile applications available and, with that, several mainstream mobile platforms solidifying, it has also played an important role in developers looking for *cross-platform solutions* to build their applications in order to reach a larger audience, and undoubtedly, to save on their efforts by avoiding to build several versions of the same application for different platforms.

One approach to cross-platform mobile development is utilizing the existing HTML4-based mobile browsers and providing mobile websites (you probably saw countless examples of these sitting at URLs like `http://m.something.com`) next to native mobile applications. These are web applications with reduced capabilities, compared to their mobile counterparts, due to their lack of web/HTML features that could provide similar user experience and functionality. Nonetheless, mobile websites played and continue to play an important role in providing content and applications on mobile devices, thus contributing to mobile device explosion. On one hand, mobile websites provide a clean and simple version of an application, therefore prompting the developers to consider the essential parts of their applications. On the other hand, mobile websites acted as a conduit to explore new and innovative uses of web applications coupled with the convenience of mobile devices.

Another parallel development is the appearance of various HTML5 standards. HTML5 is a large and constantly evolving set of standards, now covering important mobile features such as multi-touch, native-strength audio, video and camera capabilities, efficient client-server communication via web sockets, and so on. HTML5 along with CSS3 now provide a standards-driven alternative to native mobile applications, and have proven not only viable, but also in many respects, superior to native application development.

In this chapter, you will be taking a short introduction into developing mobile web applications in F# using WebSharper, the F# web framework you saw in Chapter 14. You will learn about progressive enhancement, responsive web design, feature detection and polyfilling, various HTML and JavaScript features such as multi-touch events and mobile meta tags supported on different mobile browsers, developing WebSharper mobile web applications using these features, and finally, using WebSharper Mobile to package these applications into native Android or Windows Phone applications.

---

## PROGRESSIVE ENHANCEMENT AND RESPONSIVE WEB DESIGN

---

One of the challenges of mobile web development (or ordinary web development for that matter) is accommodating the vast diversity of end-user devices that come with different capabilities to render content. In the past, one way to work with this added complexity was to detect certain devices or browsers and implicitly causing or even explicitly advising users to update to a newer version that better supports the features of the given application. This is a failed attempt to provide *graceful degradation*, a technique that starts with a feature-rich version customized to a particular browser technology and provides various fallback mechanisms for certain features when they are detected missing.

In today's world, new techniques are emerging to tackle this problem in a fundamentally different, better way. For one, you can apply *progressive enhancement*, a strategy where you develop applications based on clean and rich semantic markup that is accessible to all devices, and add more sophisticated features as enhancements in layers that, where interpreted correctly, yield an improved user experience. These enhancements can be applied on the presentation layer using various CSS and styling elements, and on the behavioral layer using client-side scripting.

We have used the term *progressive enhancement* in a similar but slightly different context in Chapter 14, where you saw how you can apply incremental enhancements to formlets and their input controls. These enhancements concerned visual details such as labels, icons, and layout, and dynamic behaviors such as validation, and were applied incrementally to build progressively more enhanced formlets.

*Responsive web design* uses progressive enhancement to enable web applications to adapt to different screen resolution and plays an important role in developing modern mobile web applications. It relies on



three fundamental building blocks: fluid grids, flexible images, and media queries. Fluid grids structure their content depending on the available screen size, and may shift cells in predictable ways to better adapt to the real estate available on the device. Flexible images resize on demand to keep the content in which they are embedded consistently formatted. Media queries provide conditional styling based on a CSS media type (such as handheld, print, projection, or tv) and an optional set of expressions that involve particular media features such as width or orientation. A handful of media query examples are shown in Table 15-1.

*Table 15-1. Examples for Media Queries*

Media Query	Note
@media screen and (max-width: 640px) {...}	Apply if the width of the viewing area is no more than 640 pixels.
@media screen and (min-width: 1024px) {...}	Apply if the width of the viewing area is at least 1024 pixels.
@media screen and (max-device-width: 480px) {...}	Apply if the width of the device is no more than 480 pixels.
@media screen and (min-device-width: 320px) {...}	Apply if the width of the device is at least 320 pixels.
@media (orientation: portrait) {...}	Apply if the orientation of the device is portrait.

## Feature Detection and Polyfilling in WebSharper

At first look, mobile web applications differ little from ordinary web applications. However, although HTML5 is spreading quickly to mobile browsers, there are still various differences that need to be dealt with on various platforms. Coming to the rescue, you should design your applications with running in different contexts in mind using *feature detection*, via a multitude of JavaScript libraries such as Modernizr (<http://modernizr.com>) or has.js. In conjunction with feature checking, you can also use what is often referred to as *polyfilling*, e.g., using JavaScript to fill in for missing browser features. Many of the polyfilling libraries exist to provide various HTML5 support such as canvas, video or audio on older browsers such as IE7 and IE8, that otherwise do not support HTML5.

It is impossible to do justice to the various available feature-checking and polyfilling libraries in one short chapter, nor are they set in stone, as there are new and better libraries appearing all the time. Instead, you can find a short list of libraries and the various features they relate to in Table 15-2.

Feature detection libraries provide an easy-to-use API to query for various browser features, often as a table lookup facility or a function call that identifies browser features with keys (usually as strings), and returning a Boolean value depending on whether the given feature is supported in the executing context or not. For instance, in has.js, you can check whether the end user's browser supports HTML5/video with the following JavaScript snippet:

```
if(has("video")) {
    // Your envioment supports HTML5 video
} else {
    // It doesn't, so you must use some kind of video polyfill
}
```

Modernizr also provides a convenient shorthand notation not only to check for various features, but also to polyfill them if they are absent. Consider the following Modernizr JavaScript snippet:

```
Modernizr.load({
  test: Modernizr.geolocation,
  yep : 'geo.js',
  nope: 'geo-polyfill.js'
});
```

This snippet defines a conditional loading of a script based on the result of a particular test function `Modernizr.geolocation`, which checks for geolocation support in the executing environment. Modernizr includes a large number of tests for various CSS, JavaScript, HTML5, and other features you can use in your applications to detect context support and fall back accordingly.

*Table 15-2. Some Notable Polyfill Libraries Available*

Name	Library URL	Type
AmplifyJS	<a href="http://amplifyjs.com/">http://amplifyjs.com/</a>	HTML5/LocalStorage
audio.js	<a href="http://kolber.github.com/audiojs/">http://kolber.github.com/audiojs/</a>	HTML5/Audio
excanvas	<a href="http://code.google.com/p/explorercanvas/">http://code.google.com/p/explorercanvas/</a>	HTML5/Canvas
Flashcanvas	<a href="http://flashcanvas.net/">http://flashcanvas.net/</a>	HTML5/Canvas
HTML-History-API	<a href="https://github.com/devote/HTML5-History-API">https://github.com/devote/HTML5-History-API</a>	HTML5/History
MediaElement.JS	<a href="http://mediaelementjs.com/">http://mediaelementjs.com/</a>	HTML5/Video+Audio
pdf.js	<a href="https://github.com/mozilla/pdf.js">https://github.com/mozilla/pdf.js</a>	PDF
Raphaël	<a href="http://dmitrybaranovskiy.github.io/raphael/">http://raphaeljs.com</a>	SVG/VML Graphics
Shumway	<a href="https://github.com/mozilla/shumway">https://github.com/mozilla/shumway</a>	Flash
Socket.IO	<a href="http://socket.io">http://socket.io</a>	HTML5/WebSockets
Video.js	<a href="http://videojs.com">http://videojs.com</a>	HTML5/Video

To use JavaScript libraries like Modernizr or `has.js` in your WebSharper applications, you have several choices. First, you can define JavaScript inlines in your WebSharper code to “stub” certain functions and to instruct WebSharper to output your inlines for them at code generation time. For this to work correctly, you need to make sure that the module containing your inlined functions is properly annotated to require any JavaScript/CSS artifacts that belong to the library you are referencing. Here is an example to inline `has.js`'s `has(...)` function you saw earlier and to make it available to your F# code as `HasJs.Has`:

```
open IntelliFactory.WebSharper

module MyResources =
  type HasJs() =
    inherit Resources.BaseResource("http://[put-URL-here]/has.js")

  module Features =
    type Video() =
      inherit Resources.BaseResource("http://[put-URL-here]/has.js")

    ...

[<Require(typeof<MyResources.HasJs>>)]
module HasJs =
  module Features =
```

```
[<Require(typeof<MyResources.Features.Video>)>]
[<JavaScript>]
let Video() = "video"
...

[<Inline("has($s) ? $ifyes() : $ifno()")>]
let Has (s: string) (ifyes: unit -> unit) (ifno: unit -> unit) =
    ()
```

With this JavaScript stub, your WebSharper code could use `has.js` to detect various browser features. For instance, the snippet you saw above could be phrased in WebSharper as:

```
do HasJs.Has (HasJs.Features.Video())
  <| fun () ->
    // Your enviroment supports HTML5 video
    ...
  <| fun () ->
    // It doesn't, so you must use some kind of video polyfill
    ...
```

In addition to manually stubbing out JavaScript functions with inlines, you can also create a new WebSharper extension for your JavaScript library at hand using the WebSharper Interface Generator tool you saw in Chapter 14. Extensions are an essential part of using WebSharper because they provide the bridge to the outside world and to any JavaScript library; and you may find the need to build WebSharper extensions from time to time, either to existing third-party JavaScript libraries or to libraries of your own. You will see an example of developing a WebSharper extension to a small part of the Facebook API later in this chapter.

Alternatively, you can check if a given WebSharper extension is already available on the WebSharper downloads page at <http://websharper.com/downloads>. WebSharper extensions are added regularly, so there is a good chance that someone has already done the work for you. At the time of writing, WebSharper has over two dozen extensions available, covering a good selection of mobile libraries, including jQuery Mobile (<http://jquerymobile.com/>), Sencha Touch (<http://www.sencha.com/products/touch/>), and Kendo UI (<http://kendoui.com/>), and many other JavaScript libraries you can use in your web or mobile web applications.

## Mobile Capabilities, Touch Events, and Mobile Frameworks

One of key differentiators of mobile applications is the ability to use various touch events to control them. You will see later in this chapter how you can add handlers to these events using JavaScript libraries, such as jQuery Mobile, that provide access to vendor-specific JavaScript events in a unified way. There are a growing number of similar JavaScript libraries that aim to enable your applications to respond to touch events. For instance, `hammer.js` (<http://eightmedia.github.com/hammer.js>) and `zepto.js` (<http://zeptojs.com>) both provide support for touch events. Table 15-3 summarizes the different kinds of touch events that emerged as “standard” on touch-based devices.

*Table 15-3. Summary of Touch Events*

Event	Description
Tap	Touching on a single point for a short period.
Double Tap	Tapping on a single point twice within a time threshold.

Event	Description
Swipe	Touching on a single point and moving horizontally or vertically.
Hold	Touching on a single point for a longer period.
Transform	Touching on at least two points and moving them in any direction.
Drag / Pan	Touching on a single point and moving in any direction.

Beyond single and multi-touch events, mobile devices also provide a number of other capabilities to applications running on them. Some of these mobile capabilities are listed in Table 15-4. Mobile JavaScript libraries and frameworks, and technologies such as WebSharper Mobile (introduced later in this chapter) and PhoneGap (<http://phonegap.com>) provide access to some or all of these capabilities using JavaScript. More advanced capabilities, such as access to local storage, the file system on the device, its communication and networking capabilities, and any contacts databases stored on the device are also becoming available to JavaScript as these technologies mature.

*Table 15-4. Some Mobile Capabilities Available in Mobile Devices*

Capability	Description
Accelerometer	Providing information on the device's acceleration
Audio/Media	Playing sounds using the device's speakerphone(s)
Camera	Taking pictures using the device camera
Communication	Enabling access to the device's communication channels
Compass	Providing directional/compass information
Geolocation	Providing geolocation information using GPS or A-GPS
Vibration	Responding by vibration
Storage	Providing access to local storage
Touch and Multi Touch	Responding to touch events, summarized in Table 15-3

As you will shortly see in this chapter, serving mobile content and developing mobile web applications that use various mobile capabilities doesn't involve any magic and is actually quite fun to learn to do. To take this experience even further, a large number of JavaScript mobile web frameworks exist that not only enable you to use various mobile user interface widgets and capabilities, but also provide a sort of application framework (some basic, some nearly end-to-end) in which to develop your mobile web applications. Some of these frameworks are listed in Table 15-5.

*Table 15-5. A Handful of JavaScript Mobile Web Application Frameworks*

Framework	URL
Appcelerator Titanium	<a href="http://www.appcelerator.com/">http://www.appcelerator.com/</a>
DHTMLX Touch	<a href="http://www.dhtmlx.com/touch/">http://www.dhtmlx.com/touch/</a>
iUI	<a href="http://www.iui-js.org">http://www.iui-js.org</a>
jQuery Mobile	<a href="http://jquerymobile.com/">http://jquerymobile.com/</a>
Sencha Touch	<a href="http://www.sencha.com/products/touch/">http://www.sencha.com/products/touch/</a>
Sproutcore	<a href="http://sproutcore.com/">http://sproutcore.com/</a>
wink	<a href="http://www.winktoolkit.org/">http://www.winktoolkit.org/</a>

## Serving Mobile Content

So far in this chapter you saw how you can apply feature detection and polyfilling to accommodate different rendering environments, preparing your application to gracefully fall back on older devices and browsers. In this section, you will look at a couple fundamental details that you need to be aware of before you can start serving mobile web content, in particular, understanding how mobile browsers interpret your content differently than desktop browsers.

To start with, consider what happens when you view a basic web page with a header and some text in a desktop browser and compare it with the same page viewed in a mobile browser. You will find that the mobile browser will scale it like a web page. For instance, on Safari it will be scaled to a 980 pixels width, with the expectation that you want to surf pages like on a desktop. However, most mobile devices have fewer physical pixels and therefore the header and text in your test page will appear tiny, if at all visible.

You can fix this by embedding more information in your markup to let your mobile browser know that it is receiving content intended for mobile devices. For instance, to solve the scaling issue, you can emit an additional meta tag in the header of your page:

```
<meta name="viewport" content="width=device-width, initial-scale=1"/>
```

This tells mobile browsers to set the default width of the page to the actual width of the device (likely to something fewer than 980 pixels) and not to scale the content. You can also set `minimum-scale` and `maximum-scale` to 1 to avoid the mobile browser zooming in and out, but many users might find this less usable.

The available options for `viewport` and some further iOS meta tags are listed in Table 15-6.

*Table 15-6. Special Meta Tags Available in iOS/Safari*

Meta tag key (name="...")	Meta tag value (content="...")	Description
apple-mobile-web-app-capable	yes/no	If yes, run application in full screen mode.
apply-mobile-web-app-status-bar-style	default/black/black-translucent	In full screen mode, specifies how the status bar is displayed.
format-detection	telephone=no	Disable making strings that look like phone numbers into dial links.
viewport	width=... [980] height=... initial-scale=... maximum-scale=... [0.25] minimum-scale=... [5.0] user-scalable=... [yes]	Using comma as a separator, configure various viewport options. The defaults of each option are shown in brackets. You can use <code>device-height</code> and <code>device-width</code> to refer to the dimensions of the device.

Another way to fix the viewport is to apply a different document type, one that specifically targets mobile devices (such as XHTML Mobile Profile 1.0/1.2). However, to use HTML5 features, your best bet remains using the plain HTML5 document type:

```
<!DOCTYPE html>
```

You can serve content with this document type and with the extra meta tags programmatically as you saw in Chapter 14, or you can embed them directly into your dynamic template file. You will use this latter approach for the examples in the remainder of this chapter.

## Building a Mobile Web Application for iOS Devices

For the examples that follow in this chapter, you will be using various WebSharper extensions, providing stubs to different JavaScript libraries. Some of these extensions you will develop yourself, and some you will download from the WebSharper website (<http://websharper.com>).

In this section, you are going to build a web application that uses specific iOS/Safari mobile browser features and its JavaScript support for multi touch events. Your application will work on other mobile browsers as well, but some features such as multi-touch events may be missing. To simplify your coding, we assume that no feature detection needs to be done; you can insert these on demand in your real life coding. As you'll see, these mobile browser features provide for a user experience that is reasonably similar to native applications. Yet, the development effort and the ability to move a lot of the code to other platforms without changes makes mobile web applications much more attractive than their native counterparts.

The application you are going to be developing in this section is shown in Figure 15-1. It implements a basic image viewer application that preloads a large image and enables the user to rotate it, move it, and zoom it using multi-touch events.

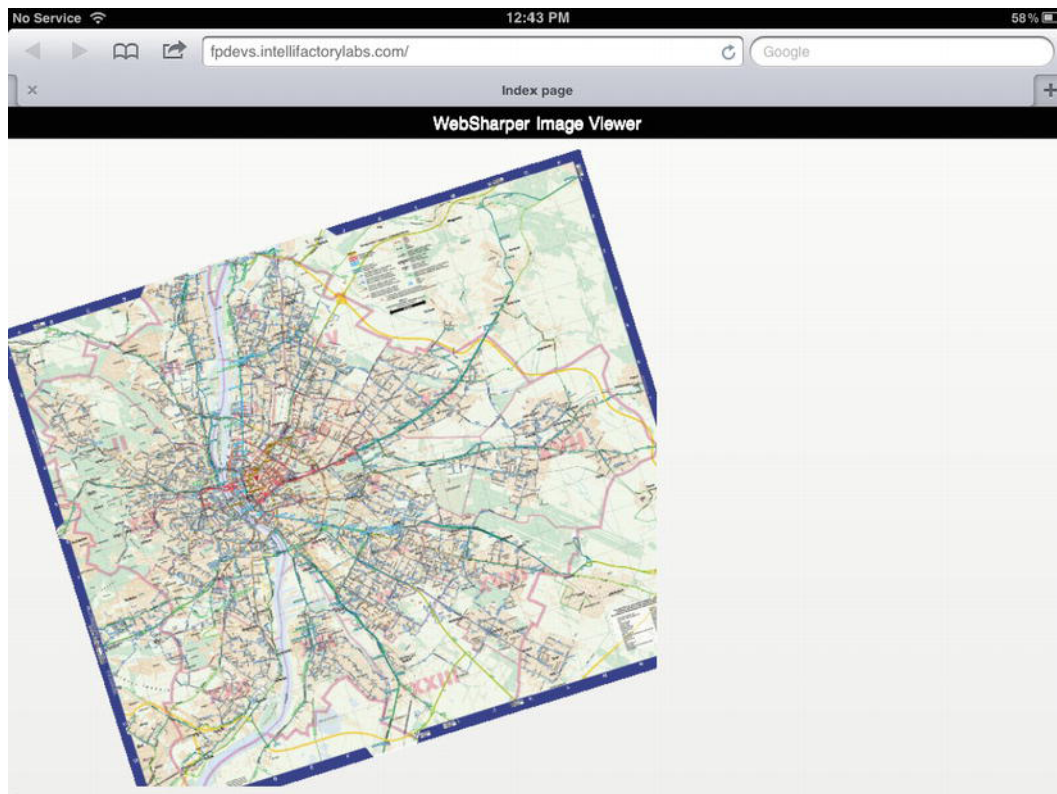

*Figure 15-1. The image viewer application running on iPad*



```

        overflow: hidden;
    }

    .head
    {
        position: absolute;
        height: 30px;
        text-align: center;
        line-height: 30px;
        background-color: Black;
        color: White;
        z-index: 1;
        width: 100%;
    }

    .head > *
    {
        float: left;
        margin-right: 10px;
    }

    .pan-image
    {
        display: none;
    }

    .pan-canvas
    {
        position: absolute;
        top: 30px;
        left: 0;
    }
    ]]></style>
</head>
<body>
    <div data-hole="body"></div>
</body>
</html>

```

Note in Listing 15-2 that you use the HTML5 document type, and that the style markup is contained in a CDATA block to avoid any XML parsing errors. WebSharper dynamic templates must be valid XML documents, and using CDATA blocks to embed text with special characters is a convenient way to get around any limitations you may encounter otherwise. And the last bit, your main content placeholder `body` is wrapped in a `div` node.

Now that you have your basic template and the extra `.files` configuration set up, the only piece left is the main application code itself. This is shown in Listing 15-3.

**Listing 15-3.** `Main.fs`

```
namespace MyNamespace
```



```

open System
open System.IO
open System.Web
open IntelliFactory.WebSharper
open IntelliFactory.WebSharper.Sitelets

module MySite =
    open IntelliFactory.Html

    type Action = | Index

    module Skin =
        type Page =
            {
                Body: Content.HtmlElement list
            }

        let MainTemplate =
            let path = Path.Combine(__SOURCE_DIRECTORY__, "Main.html")
            Content.Template<Page>(path)
                .With("body", fun x -> x.Body)

        let WithTemplate body : Content<Action> =
            Content.WithTemplate MainTemplate <| fun context ->
                {
                    Body = body context
                }

    module Client =
        open IntelliFactory.WebSharper.Html
        open IntelliFactory.WebSharper.JQuery

        type State =
            {
                mutable x: float
                mutable y: float
                mutable scale: float
                mutable angle: float
            }

        type MyControl() =
            inherit IntelliFactory.WebSharper.Web.Control()

            [<JavaScript>]
            override this.Body =
                let main = Div [Attr.Class "main"]
                let head =
                    Div [Attr.Class "head"] -< [
                        Text "WebSharper Image Viewer"
                    ]
                main -< [

```

```

head
HTML5.Tags.Canvas [
  Attr.Class "pan-canvas";Attr.Width "600";Attr.Height "600"
]
|>! OnAfterRender (fun e ->
  let canvas = As<Html5.CanvasElement> e.Body
  let ctx = canvas.GetContext "2d"
  Img [Attr.Src "images/map.jpg"; Attr.Class "pan-image"]
  |> Events.OnLoad (fun img ->
    let state = { x = 0.; y = 0.; scale = 1.; angle = 0. }
    let delta = { x = 0.; y = 0.; scale = 1.; angle = 0. }
    let redraw() =
      // Reset the transformation matrix
      // and clear the canvas.
      ctx.SetTransform(1., 0., 0., 1., 0., 0.)
      ctx.ClearRect(0., 0.,
        float canvas.Width, float canvas.Height)

      // In order to have centered rotation and zoom, we
      // must first put the center of the image at the
      // origin of the coordinate system.
      ctx.Translate(float canvas.Width / 2.,
        float canvas.Height / 2.)
      ctx.Scale(state.scale * delta.scale,
        state.scale * delta.scale)
      ctx.Rotate(state.angle + delta.angle)

      // Then, when the rotation and zoom are done, we put
      // the image back at the center of the screen, plus
      // the (x, y) translation.
      ctx.Translate(state.x+delta.x - float canvas.Width/2.,
        state.y + delta.y - float canvas.Height / 2.)
      ctx.DrawImage(img.Body, 0., 0.)
    let settleDelta() =
      state.x <- state.x + delta.x
      state.y <- state.y + delta.y
      state.angle <- state.angle + delta.angle
      state.scale <- state.scale * delta.scale
      delta.x <- 0.
      delta.y <- 0.
      delta.scale <- 1.
      delta.angle <- 0.
      redraw()
    let panStartPosition = ref None
    // Pan events
    Mobile.Events.VMouseDown.On(jQuery.Of(e.Body), fun ev ->
      panStartPosition:=Some(ev.Event.PageX, ev.Event.PageY)
      ev.Event.PreventDefault())
    Mobile.Events.VMouseMove.On(jQuery.Of(e.Body), fun ev ->
      match !panStartPosition with
      | None -> ()

```

```

    | Some (sx, sy) ->
      let dx = float(ev.Event.PageX - sx)
      let dy = float(ev.Event.PageY - sy)
      let angle = state.angle + delta.angle
      let scale = state.scale * delta.scale
      delta.x <- (dx * Math.Cos angle + dy * Math.Sin angle) / scale
      delta.y <- (dy * Math.Cos angle - dx * Math.Sin angle) / scale
      redraw()
      ev.Event.PreventDefault()
  Mobile.Events.VMouseUp.On(JQuery.Of("body"), fun ev ->
    if (!panStartPosition).IsSome then
      settleDelta()
      panStartPosition := None
      ev.Event.PreventDefault()
  // iOS-only rotozoom events
  e.Body.AddEventListener("gesturechange", (fun (ev: Dom.Event) ->
    delta.scale <- ev?scale
    delta.angle <- ev?rotation * System.Math.PI / 180.
    redraw()
    ev.PreventDefault()
  ), false)
  e.Body.AddEventListener("gestureend", (fun (ev: Dom.Event) ->
    settleDelta()
    ev.PreventDefault()
  ), false)
  redraw()
)
] :> IPagelet

let Index =
  Skin.WithTemplate <| fun ctx ->
    [
      Div [new Client.MyControl()]
    ]

let MySitelet =
  Sitelet.Content "/index" Action.Index Index

type MyWebsite() =
  interface IWebsite<MySite.Action> with
    member this.Sitelet = MySite.MySitelet
    member this.Actions = [MySite.Action.Index]

[<assembly: Website(typeof<MyWebsite>)>]
do ()

```

## Digging Deeper

The main application code above sets up basic dynamic templating based on `Main.html` in your project, and defines the main pagelet `MyControl` in the `Client` module, along with a single-page sitelet, `MySitelet`. These are then used to declare the sitelet as a website on the assembly. Note that you specified a singleton list of actions for the `Actions` member in the website declaration: this is used to instruct the offline sitelet generator tool to output the sitelet page that handles this action; in other words, to output the single HTML page in your application. This will yield an HTML file named after the single `Action` case, `index.html`. Building the project in Visual Studio successfully will pop up a Windows Explorer window containing the generated files, and you can open `index.html` in a browser to see it in action.

To use it from an iOS device, you need to publish the application to a public URL and open that URL in your iPad's or iPhone's Safari browser. These devices support multi-touch events, so you should be able to rotate and scale the image you added to your application.

Now, let's look at how the application works. The main client-side control `Client.MyControl` creates the following dynamic markup:

```
<div class="main">
  <div class="head">WebSharper Image Viewer</div>
  <canvas class="pan-canvas" width="600" height="600">
  </canvas>
</div>
```

When the `<canvas>` element is first created and rendered, the `OnAfterRender` event is fired. This event handler is the heart of your application and is attached using the `|!>` operator, which registers a callback function to the given event without returning the parent DOM node. First, it creates an `<img>` node and loads the image you added earlier to the project. Although this image is never added as an actual DOM node, creating it dynamically still causes the browser to construct it and to call its `OnLoad` event. This event then performs a number of steps:

- Creates some bookkeeping for representing the visual state and the delta in between various touch events
- Defines a `redraw()` function that draws the loaded image onto the `<canvas>` element respecting the current state and delta registers
- Defines a `settleDelta()` function that propagates the current delta register into the state and initiates a redraw
- Registers various event handlers

The general format for registering an event handler involves finding the event handler by name and registering a callback function to it taking the event argument and performing the actions you need.

In the above example, you take two different approaches for binding to various events. Recall that earlier you added a reference to `WebSharper Extensions for jQuery Mobile` to your project. You did this because `jQuery Mobile` provides a useful abstraction over single-touch events under what it calls *virtual mouse* events, making touch and mouse events uniform regardless of running on mobile or desktop browsers. These events can be addressed with the `jQuery Mobile` extensions in a type-safe manner:

```
Mobile.Events.VMouseDown.On(jQuery.Of(e.Body), fun ev ->
  panStartPosition := Some (ev.Event.PageX, ev.Event.PageY)
  ev.PreventDefault())
```

The above call registers an event handler for `jQuery Mobile`'s `VMouseDown` event: the event that occurs when the user clicks down using the mouse or when a touch device is touched. The event handler is added to the canvas element (represented by `e`), and the callback function takes an event arguments parameter `ev`

of type `Mobile.VMouseEventArgs`. This type contains various important virtual mouse-related members, such as `ClientX`, `ClientY`, `ScreenX`, `ScreenY`, and an `Event` member to refer back to the underlying jQuery event object. This object carries, among others, the click/touch coordinates in `PageX` and `PageY`.

The various other events available in the `IntelliFactory.WebSharper.Mobile.Events` class are summarized in Table 15-7. Many of these events are key to mobile applications, providing interactions such as swiping, scrolling, and tapping on a mobile device, and responding to important events such as changes in the orientation of the device or updating the presentation layout.

Next to binding to events using jQuery Mobile, the second approach you saw in the example above involves binding to non-standard events, such as the multi touch events not available in the current version of WebSharper Extensions for jQuery Mobile, using the plain JavaScript event binding primitive `AddEventListener`. Consider the following snippet from the example:

```
e.Body.AddEventListener("gesturechange", (fun (ev: Dom.Event) ->
    delta.scale <- ev?scale
    delta.angle <- ev?rotation * System.Math.PI / 180.
    redraw()
    ev.PreventDefault()
), false)
```

This registers an event handler for the `gesturechange` event, a non-standard event available in iOS/Safari browsers. Here, the callback function takes a plain DOM event object that contains standard JavaScript functions to manipulate how the event is propagated (such as `PreventDefault`), where and when it was initiated, etc. It also contains in various browser implementations additional pieces of data that are tagged onto it for specific events. In the above snippet, `scale` and `rotation` are extracted using the dynamic access operator (`?`). This operator attempts to fetch from its first argument a field with a name given by an F# identifier following it: roughly the dynamic equivalent of the dot used for ordinary .NET member access. In our example, `scale` and `rotation` are known to be available in browsers that support the `gesturechange` event (most notably, iOS/Safari), but in general, you should provide for a fallback when the dynamic lookup fails.

**Table 15-7.** Mobile Events Provided by WebSharper Extensions for jQuery Mobile

Event	Type	Description
OrientationChange	<code>Mobile.Event&lt;Mobile.OrientationChangeEvent&gt;</code>	Triggered when the orientation of the devices changes. [portrait   landscape]
ScrollStart	<code>Mobile.Event</code>	Triggered when scrolling starts.
ScrollStop	<code>Mobile.Event</code>	Triggered when scrolling stops.
Swipe	<code>Mobile.Event</code>	Triggered when a horizontal drag occurs within a specific duration.
SwipeLeft	<code>Mobile.Event</code>	Triggered when a swipe event occurs moving in the left direction.
SwipeRight	<code>Mobile.Event</code>	Triggered when a swipe event occurs moving in the right direction.
Tap	<code>Mobile.Event</code>	Triggered after a quick, complete touch event.
TapHold	<code>Mobile.Event</code>	Triggered after a held complete touch event.
UpdateLayout	<code>Mobile.Event</code>	Triggered when the application's layout changes.
VClick	<code>Mobile.Event</code>	Triggered on a mouse click or a touch event.
VMouseCancel	<code>Mobile.Event</code>	Triggered when a virtual mouse event is cancelled.

Event	Type	Description
VMouseDown	Mobile.Event	Triggered on a mouse or touch click down event.
VMouseMove	Mobile.Event	Triggered on a mouse or touch move event.
VMouseOut	Mobile.Event	Triggered on a mouse or touch out event.
VMouseOver	Mobile.Event	Triggered on a mouse or touch over event.
VMouseUp	Mobile.Event	Triggered on a mouse or touch up event.

## Developing Social Networking Applications

In the previous section you saw how you can build an HTML5 mobile application that uses specific mobile browser features such as multi-touch events to enhance user experience. In this section, you are going to build another HTML5 mobile application that interfaces with the Facebook API (<http://developers.facebook.com>) to retrieve a Facebook user's status updates and to display them in a mobile application built with WebSharper Extensions for jQuery Mobile. The example demonstrates how you can build a WebSharper extension to the subset of the Facebook API you need, and how to use this extension to build an HTML5 application that is enhanced to run on mobile devices using the jQuery Mobile library and its corresponding WebSharper extension.

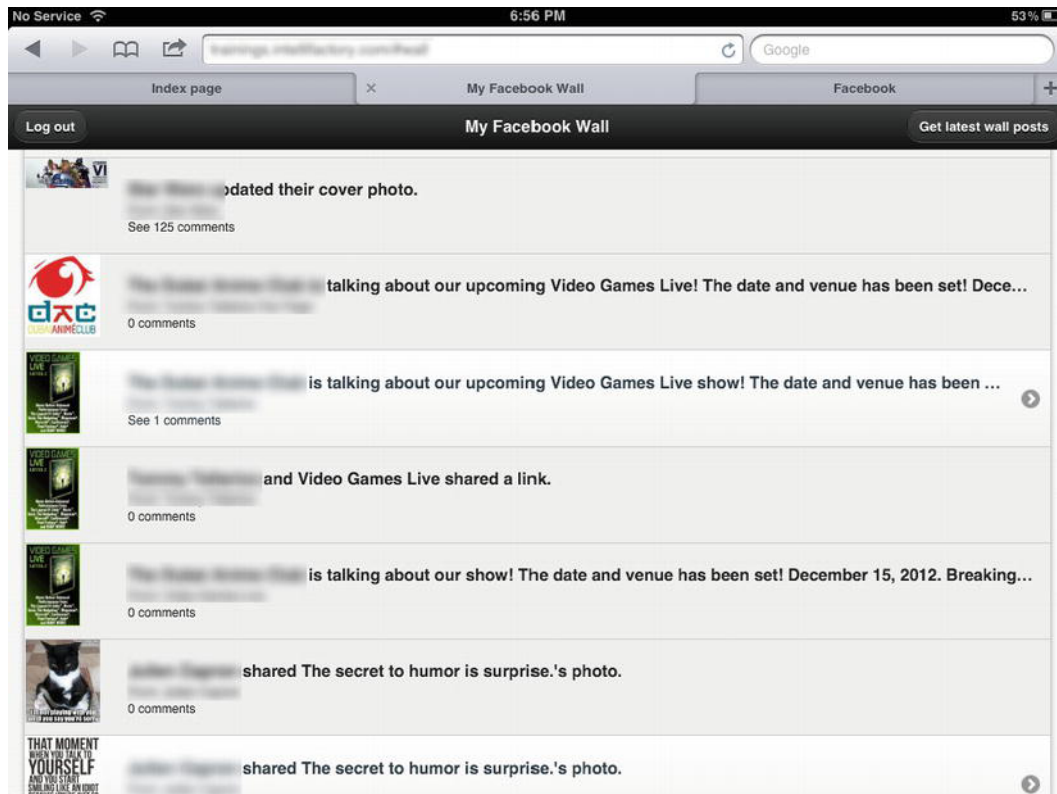

Figure 15-2. Displaying Facebook status messages

The application in this section is built as a multi-project solution in Visual Studio. You should start by creating a WebSharper Extension project, and later add a WebSharper HTML Site project to complete the application. As a first step, after you created your new Extension project, replace the contents of `Main.fs` with the code in Listing 15-4.

**Listing 15-4.** `Main.fs` – Defining a WebSharper Extension to a Part of Facebook API

```
namespace IntelliFactory.WebSharper.Facebook

module Definition =
    open IntelliFactory.WebSharper.InterfaceGenerator
    open IntelliFactory.WebSharper.Dom

    module Res =
        let FacebookAPI =
            Resource "FacebookAPI" "https://connect.facebook.net/en_US/all.js"

    let FlashHidingArgs =
        Class "FB.FlashHidingArgs"
        |> Protocol [
            "state" =? T<string>
            "elem" =? T<Element>
        ]

    let InitOptions =
        Pattern.Config "FB.InitOptions" {
            Required = []
            Optional =
                [
                    "appId", T<string>
                    "cookie", T<bool>
                    "logging", T<bool>
                    "status", T<bool>
                    "xfbml", T<bool>
                    "channelUrl", T<string>
                    "authResponse", T<obj>
                    "frictionlessRequests", T<bool>
                    "hideFlashCallback", FlashHidingArgs ^-> T<unit>
                ]
        }

    let AuthResponse =
        Class "FB.AuthResponse"
        |> Protocol [
            "accessToken" =? T<string>
            "expiresIn" =? T<string>
            "signedRequest" =? T<string>
            "userId" =? T<string>
        ]
```

```

let UserStatus =
    Pattern.EnumStrings "FB.UserStatus"
        ["connected"; "not_authorized"; "unknown"]

let LoginResponse =
    Class "FB.LoginResponse"
    |> Protocol [
        "authResponse" =? AuthResponse
        "status" =? UserStatus
    ]

let LoginOptions =
    Pattern.Config "FB.LoginOptions" {
        Optional =
            [
                "scope", T<string>
                "display", T<string>
            ]
        Required = []
    }
}

let FB =
    Class "FB"
    |> [
        "init" => !?InitOptions ^-> T<unit>
        "login" => (LoginResponse ^-> T<unit>) * !?LoginOptions ^-> T<unit>
        "logout" => (LoginResponse ^-> T<unit>) ^-> T<unit>
        "getLoginStatus" => (LoginResponse ^-> T<unit>) ^-> T<unit>
        "getAuthResponse" => T<unit> ^-> AuthResponse
        "api" => T<string>?url * !?T<string>'?'method' * !?T<obj>?options * (T<obj> ^->
T<unit>)?callback ^-> T<unit>
    ]
    |> Requires [Res.FacebookAPI]

let Assembly =
    Assembly [
        Namespace "IntelliFactory.WebSharper.Facebook" [
            FlashHidingArgs
            InitOptions
            AuthResponse
            UserStatus
            LoginResponse
            LoginOptions
            FB
        ]
        Namespace "IntelliFactory.WebSharper.Facebook.Resources" [
            Res.FacebookAPI
        ]
    ]
]

```



```

module Main =
    open IntelliFactory.WebSharper.InterfaceGenerator

    do Compiler.Compile stdout Definition.Assembly

```

The various operators you see in this code listing are explained in more detail in the WebSharper documentation in the chapter that describes the WebSharper Interface Generator tool. For instance, given a class type defined via the `Class` function, `|+>` enhances it with new members. You can create a new member giving its name as a string, the `=>` operator, and its type. In addition, you can also use the `=?/=!/=@` operators to create a read-only/write-only/mutable property, or `=%` to create a field. Types are constructed using the types you created in code, using the `T<...>` operator to refer to existing .NET types, using the star (\*) operator for tuple types, using the `^->` operator for function types, using the `!?` operator for optional parameters, and `!+` operator for a variable number of arguments, among others.

The extension definition above covers a subset of the Facebook API. In particular, it deals with authenticating users, retrieving their login status, and provides a generic `api` function to retrieve various bits of information from the Facebook service. These functions are defined in a class called `FB`, inside the main `IntelliFactory.WebSharper.Facebook` namespace, along with the various configuration and helper types necessary. To make these functions work correctly at runtime, the `FB` class is enhanced to require the main Facebook API JavaScript file, defined as the resource `Res.FacebookAPI`, pointing to the Facebook domain. This resource will be automatically referenced and included in any sitelet page or ASPX markup that uses the functionality provided by the `FB` class.

## Configuring Your New Facebook Application

Before you can implement the main application code, you need to register your application with Facebook to receive an ID that you can use to query the Facebook API. To register your application, go to <http://developers.facebook.com/apps>, sign in if you haven't already, make sure your account is verified, and click the **Create New App** button on the top. In the popup in Figure 15-3, add the name of your application, select if you need optional hosting, and click **Continue**.

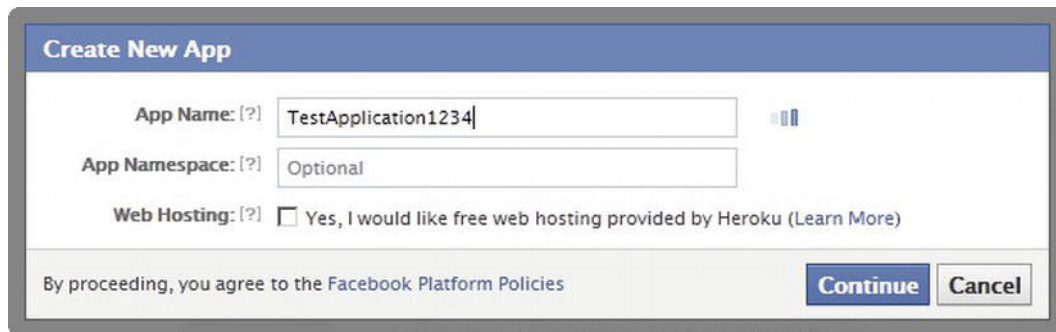

*Figure 15-3. Creating a new Facebook application*

In the next step, you need to enter some CAPTCHA validation, and then proceed onto setting up the application properties. By this point, your new Facebook application has been created and it has a unique ID and secret code pair as shown in Figure 15-4, and shortly you will need the former in your application code.



Figure 15-4. The unique identifiers of your Facebook application

But first, in the Basic Info panel, enter the URL of your new application: either the URL where you will be manually hosting your application files, or you can create and configure a hosting domain on Heroku if you have chosen to tick the Web Hosting option in the previous step. You can see an example setup in Figure 15-5, where you used Heroku to host your application files.

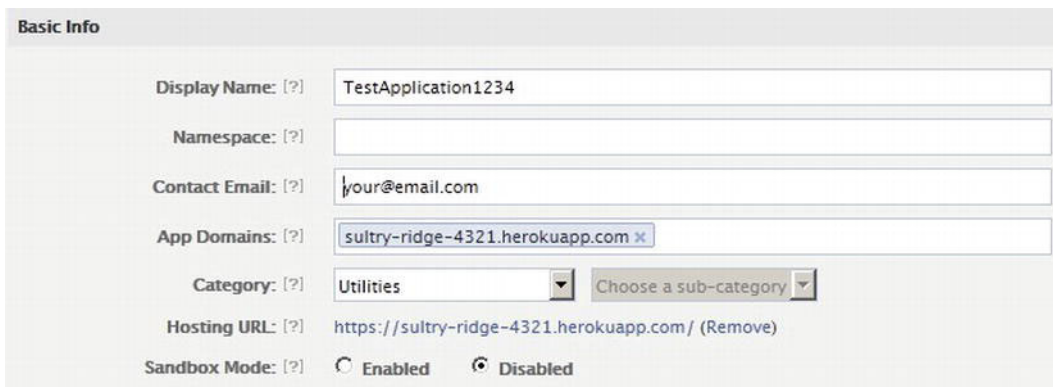

Figure 15-5. Configuring the domains and the URL of your application

As a last configuration step, enter your application URL in the Website with Facebook Login option of the application integration section as shown in Figure 15-6.

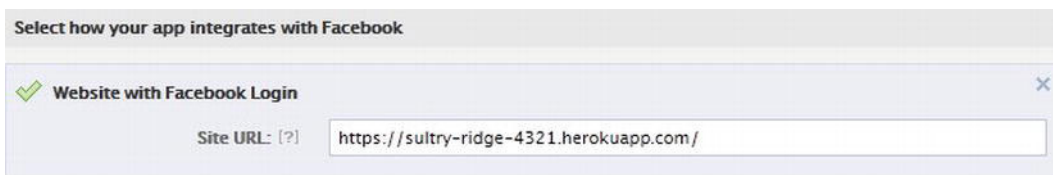

Figure 15-6. Configuring your application

## Defining the Main HTML Application

The main HTML application uses the same kind of dynamic templating that you saw in the previous section. The template markup in Main.html is shown in Listing 15-5.

*Listing 15-5. Main.html – Defining the Dynamic Template for the Facebook Application*

```

<!DOCTYPE html>
<html>
  <head>
    <title>My Facebook Wall</title>
    <meta name="viewport" content="width=device-width, initial-scale=1" />
    <meta name="generator" content="websharper" data-replace="scripts" />
  </head>
  <body>
    <div data-replace="body" />
    <div data-role="page" id="dummy" />
  </body>
</html>

```

The templating functionality should look familiar to you already. The main application is placed in the Client module and is shown in Listing 15-6.

*Listing 15-6. Main.fs – The Application Code*

```

namespace IntelliFactory.Facebook.Application

open System
open System.IO
open IntelliFactory.WebSharper.Sitelets

module MySite =
  open IntelliFactory.WebSharper
  open IntelliFactory.Html

  type Action = | Index

  module Skin =

    type Page =
      {
        Body : Content.HtmlElement list
      }

    let MainTemplate =
      let path = Path.Combine(__SOURCE_DIRECTORY__, "Main.html")
      Content.Template<Page>(path)
        .With("body", fun x -> x.Body)

    let WithTemplate body : Content<Action> =
      Content.WithTemplate MainTemplate <| fun context ->
        {
          Body = body context
        }

  module Client =
    open IntelliFactory.WebSharper.Html

```

```

open IntelliFactory.WebSharper.Facebook
open IntelliFactory.WebSharper.JQuery
open IntelliFactory.WebSharper.JQuery.Mobile

type Control() =
    inherit IntelliFactory.WebSharper.Web.Control()

    [<JavaScript>]
    let (|!?) (x: 'a) (y: 'a) = if As<bool> x then x else y

    [<JavaScript>]
    override this.Body =
        Mobile.Use()
        Mobile.Instance.DefaultPageTransition <- "slide"
        FB.Init(InitOptions(AppId="<<PUT-YOUR-APPID-HERE>>"))
        let btncStatus = Span [Text "Log in"]
        let btnGetPosts =
            A [
                Text "Get latest wall posts"
                Attr.HRef "#"; Attr.Style "display: none;"
            ]
        let updateStatus (resp: LoginResponse) =
            if resp.Status = UserStatus.Connected then
                btncStatus.Text <- "Log out"
                JQuery.Of(btnGetPosts.Body).Show().Ignore
            else
                btncStatus.Text <- "Log in"
                JQuery.Of(btnGetPosts.Body).Hide().Ignore
        let wallPage =
            Div [
                Attr.Id "wall"; HTML5.Attr.Data "role" "page"
                HTML5.Attr.Data "url" "#wall"
            ]
        let wall =
            UL [
                HTML5.Attr.Data "role" "listview"
                HTML5.Attr.Data "inset" "true"
            ]
        wallPage <- [
            Div [
                HTML5.Attr.Data "role" "header"
                HTML5.Attr.Data "position" "fixed"
            ] <- [
                H1 [Text "My Facebook Wall"]
                A [Attr.HRef "#"] <- [btncStatus]
                |>! OnClick (fun el ev ->
                    FB.GetLoginStatus <| fun resp ->
                        if resp.Status = UserStatus.Connected then
                            FB.Logout updateStatus
                        else
                            FB.Login(

```

```

        updateStatus,
        LoginOptions(Scope = "read_stream"))
    )
    |>! OnAfterRender (fun _ -> FB.GetLoginStatus updateStatus)
    btnGetPosts
    |>! OnClick (fun e1 ev ->
        Mobile.Instance.ShowPageLoadingMsg("a","Receiving posts")
        FB.Api("/me/home", fun o ->
            wall.Clear()
            o?data |> Array.iter (fun x ->
                let message = x?message ||? x?story ||? x?caption
                LI [
                    yield H6 [Text message]
                    yield P [Text ("From: " + x?from?name)]
                    let numComments =
                        if x?comments && x?comments?count > 0 then
                            "See " + x?comments?count
                        else
                            "0"
                    yield P [Text (numComments + " comments")]
                    yield Img [Attr.Src (if x?picture then x?picture else "")]
                    if x?comments && x?comments?data then
                        yield UL [
                            yield! x?comments?data |> Array.map (fun comment ->
                                LI [
                                    H6 [Text comment?message]
                                    P [Text comment?from?name]
                                ]
                            )
                        yield LI [
                            HTML5.Attr.Data "iconpos" "left";
                            HTML5.Attr.Data "icon" "arrow-l"] -< [
                                A [Attr.HRef "#"] -< [Text "Back"]
                                |>! OnClick (fun _ _ ->
                                    Mobile.Instance.ChangePage(
                                        JQuery.Of(wallPage.Body),
                                        ChangePageConfig(
                                            Reverse = true))
                                )
                            ]
                        ]
                    ]
                ]
            |> wall.Append
            Mobile.Instance.HidePageLoadingMsg()
        )
        JQuery.Of(wall.Body) |> ListView.Refresh
    )
    )
]
Div [HTML5.Attr.Data "role" "content"] -< [wall]
]

```

```

    |>! OnAfterRender (fun el ->
        JQuery.Of(el.Body)
        |> JQuery.Page
        |> Mobile.Instance.ChangePage
    ) :> IPagelet

let Index =
    Skin.WithTemplate <| fun ctx ->
        [
            Div [new Client.Control()]
        ]

let MySitelet =
    Sitelet.Content "/" Action.Index Index

type MyWebsite() =
    interface IWebsite<MySite.Action> with
        member this.Sitelet = MySite.MySitelet
        member this.Actions = [MySite.Action.Index]

[<assembly: Website(typeof<MyWebsite>)>]
do ()
    The main client control creates the following skeleton markup:
    <div id="wall" data-role="page" data-url="#wall">
        <div data-role="header" data-position="fixed">
            ...
        </div>
        <div data-role="content">
            <ul data-role="listview" data-inset="true">
                ...
            </ul>
        </div>
    </div>

```

This markup represents a jQuery Mobile “page” with a header and a content panel, the latter with a list of items displayed. Pages are an essential user interface abstraction in jQuery Mobile, as they provide the basic building blocks of multi-page applications where control transfers from one page to another usually enhanced with some sort of visual effect such as sliding in and out, creating a native-like user experience.

In the example above, the header part of the main page contains a title and two buttons: one that reflects the user’s login status and displays Log in or Log out, accordingly, and another to fetch the user’s wall posts if the user is logged in. This piece of logic is implemented in the `updateStatus` function, which is called when the user logs in or signs out. Logging in and signing out is implemented using the `FB.Login` and `FB.Logout` functions, respectively. Logging in prompts the familiar Facebook login as a new page, and upon successfully authenticating with it, the popup is closed and control is returned to the requesting page. It is therefore important that your application sits on a public URL and that this URL is set up correctly with Facebook, so this redirection can successfully happen.

The main part of the application is in the Click event handler for `btnGetPosts`: the “Get latest wall posts” button. Since the call to the Facebook API to retrieve the user’s wall posts can take a few moments, a loading animation is shown using `Mobile.Instance.ShowPageLoadingMsg`. This animation is then turned off by the time control is transferred to handling the data returned from the Facebook service. This is initialized with an `FB.Api` call to `/me/home`, and registering a callback to display the data received. The data

you get back from this call is highly dynamic in structure and may contain different pieces for the different types of wall posts. The following line is used to extract either the message, the story, or the caption (for picture posts) of the post:

```
let message = x?message ||? x?story ||? x?caption
```

This bit uses the dynamic “OR” operator `||?` you defined earlier in the `Client` module. This operator uses the fact that a dynamic lookup (using the standard `?` operator) in a record for a non-existing field returns null, which can be checked against as a Boolean value. So the fragment above returns either the message, the story, or the caption fields – whichever is non-null first in the given order. You should refer to the Facebook API documentation for the various post types and the structure they adhere to in case you need to cater to further post types.

The code then returns an LI node for each wall post retrieved and these are then wrapped inside the main UL list view placeholder node. These LI nodes contain the extracted message text, the author of the post, the number of comments, and an optional image that might accompany the post. Any embedded comment data is shown as a nested list view with a Back button to return to the original post.

You should take a look at the Facebook API and incorporate new bits of it into your WebSharper extension, and in turn use these in your application to provide more features such as posting comments, enabling users to like posts, etc. These pieces of functionality are straightforward to add, and you are urged to try out more possibilities the Facebook API and a bit of WebSharper coding can enable.

## WebSharper Mobile

In the previous sections you saw how you can build web applications that use specific mobile browser features and WebSharper mobile extensions to implement a native-like user experience on various mobile devices. These included the ability to use the entire device screen for your applications, adding them as icons to your iOS device, using multi-touch events and other gestures, etc. In this section, you are going to build native application packages using WebSharper Mobile, a set of extensions to WebSharper that provide mobile capabilities and native application containers for mobile web applications. These mobile features are shipped with the standard WebSharper installer.

The native mobile capabilities supported in WebSharper Mobile across different platforms are encapsulated in `IntelliFactory.WebSharper.Mobile` as a set of interfaces and helper types, and are given concrete implementations in the corresponding mobile namespaces such as `IntelliFactory.WebSharper.Android`. At the time of writing, WebSharper Mobile supports creating native applications for Android and Windows Phone, and exposes WebSharper access to accelerometer and geo location data, camera functionality, and logging. These members are summarized in Tables 15-8, 15-9, 15-10, and 15-11.

*Table 15-8. Members Related to Acceleration in `IntelliFactory.WebSharper.Mobile.IAcceleration`*

Member	Type	Description
<code>AccelerationChange</code>	<code>IEvent&lt;Mobile.Acceleration&gt;</code>	Allows subscription to acceleration updates
<code>IsMeasuringAcceleration</code>	<code>Bool</code>	Gets or sets the state of acceleration subscription

*Table 15-9. Members Related to Locations in `IntelliFactory.WebSharper.Mobile.IGeocator`*

Member	Type	Description
<code>GetLocation</code>	<code>unit -&gt; Async&lt;Mobile.Location&gt;</code>	Returns the current location of the device

**Table 15-10. Members Related to Logging in `IntelliFactory.WebSharper.Mobile.ILog`**

Member	Type	Description
Trace	Mobile.Priority -> string -> string -> unit	Traces a message to the system log

**Table 15-11. Members Related to Camera Support in `IntelliFactory.WebSharper.Mobile.ICamera`**

Member	Type	Description
Location.Latitude	Double	Gets the latitude of the current location
TakePicture	unit -> Async<Mobile.Jpeg>	Uses the device camera, if available, to take a picture

The concrete platform implementations may also contain specific features beyond the core set of mobile functions. For instance, WebSharper, at the time of writing, provides experimental support to Bluetooth communication on Android devices. This API is listed in Table 15-12.

**Table 15-12. Members in `IntelliFactory.WebSharper.Android.Bluetooth`**

Member	Type	Description
CancelDiscovery	unit -> unit	Cancels the Bluetooth discovery process
ConnectToDevice	Bluetooth.Device * string -> Async<Bluetooth.Socket>	Connects to the given Bluetooth device asynchronously
Enable	unit -> async<unit>	Enables Bluetooth on the device
GetBondedDevices	unit -> seq<Bluetooth.Device>	Gets all paired Bluetooth devices
MakeDiscoverable	int -> Async<unit>	Makes the current device discoverable for a given number of seconds.
Serve	string -> string -> (Bluetooth. Connection -> Async<unit>) -> Bluetooth.Server	Starts a Bluetooth server with the given name and UUID
StartDiscovery	unit -> unit	Starts the Bluetooth device discovery process
Discovery	IEvent<Bluetooth.Device>	The Bluetooth device discovery event
IsDiscoverable	bool	Tests if the current Android device is discoverable via Bluetooth
IsDiscovering	bool	Tests if the Bluetooth device discovery process is active
IsEnabled	bool	Tests if Bluetooth is enabled on the current Android device
this.Get	unit -> Bluetooth.Context option	Gets a Bluetooth context, if present on the current platform

The easiest way to get started developing native mobile applications with WebSharper is by creating a WebSharper Android or Windows Phone Application project. These templates contain, beyond the basic offline sitelet library hooks and the basic WebSharper Mobile foundation, the Android and Windows Phone implementations of the WebSharper Mobile core capabilities and any platform-specific extensions, respectively.



## Developing Android Applications with WebSharper

In this section, you will be developing a small native Android application that combines some of the WebSharper Mobile capabilities with specific extensions such as Formlets for jQuery Mobile and Bing Maps. In particular, Formlets for jQuery Mobile provides a formlet abstraction using the jQuery Mobile look and feel, giving you the ability to define type-safe, composable mobile user interfaces: an important building block to declaratively build native mobile applications with attractive user interfaces.

The application you will develop is shown in Figure 15-7, running on the Android emulator from the Android SDK. It constructs a simple login dialog using jQuery Mobile formlets, and proceeds onto a page with a Bing map showing your current location, updating regularly to reflect the user's location as he or she may be moving around. Naturally, to see this application in action you should deploy it on an actual Android device; nonetheless, testing with the Android emulator is a good way to get going. Alternatively, you can also test device-neutral functionality in a plain browser such as Firefox or Chrome.

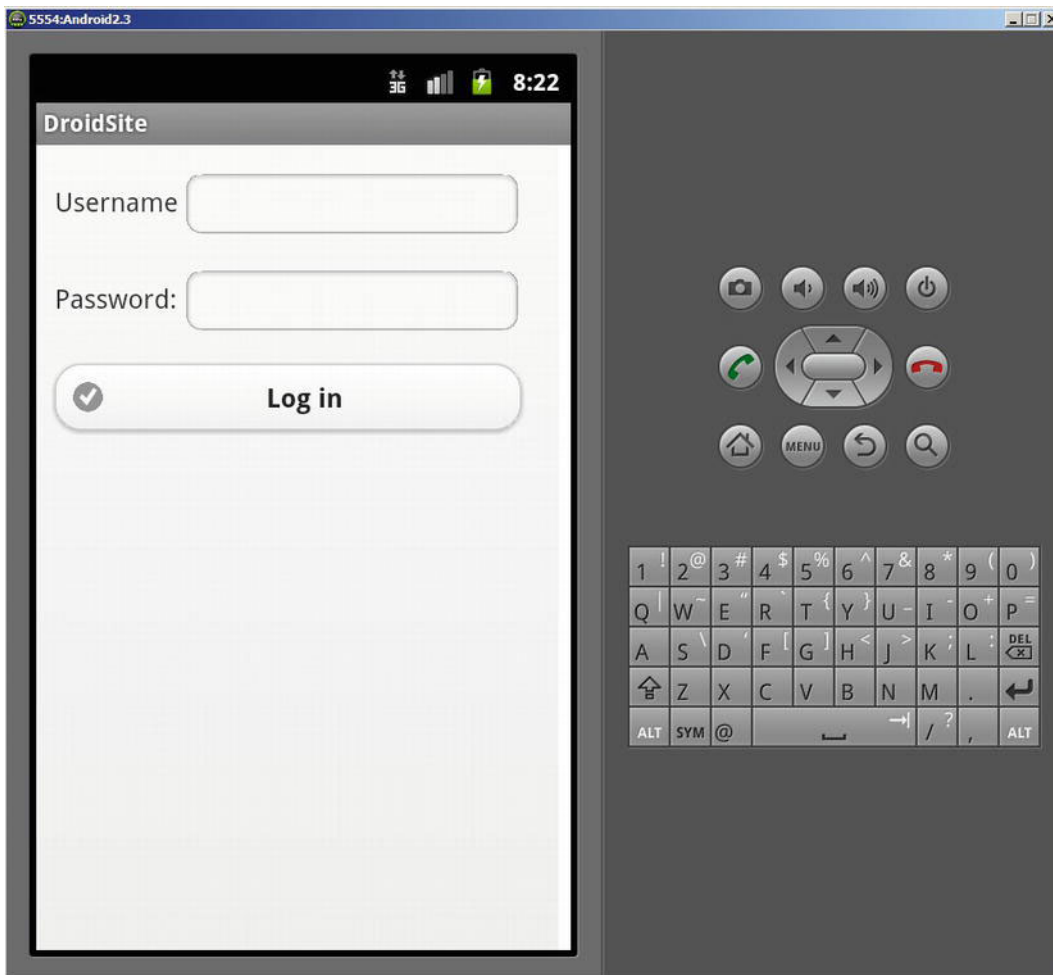

Figure 15-7. Your native Android application running in the Android emulator

## Setting Up and Testing with Your Android Environment

To develop for Android, and before you get started with your application, you should make sure to have the following prerequisites installed and set up on your machine:

- The Java Development Kit (JDK) 7, available from <http://www.oracle.com/technetwork/java/javase/downloads/jdk-7u4-downloads-1591156.html>
- The Android SDK, available from <http://developer.android.com/sdk/index.html>
- Apache Ant, available from <http://ant.apache.org/>
- Set `JAVA_HOME` to the path of your JDK installation, such as `c:\Program Files\Java\jdk1.7.0`
- Set `ANDROID_SDK` to the path of your Android SDK, such as `c:\android-sdk`
- Set `ANT_HOME` to the path of your Ant installation, such as `c:\tools\apache-ant-1.8.4`
- Add the values of `%JAVA_HOME%`, `%ANDROID_SDK%`, `%ANDROID_SDK%\platform-tools`, and `%ANT_HOME%` to your `PATH`

Figure 15-8 shows the Android SDK Manager, the tool you can use to manage your installed Android APIs and their associated libraries. This tool will also notify you if you have updates to any library, or when a new API version or revision is published. Android has evolved quickly, and up to date, still enjoys a strong momentum of updates, with consecutive API versions introducing new and enriched capabilities and a wider reach of mobile devices to run on. Android 3.X or above is an appropriate choice for tablets, so if you

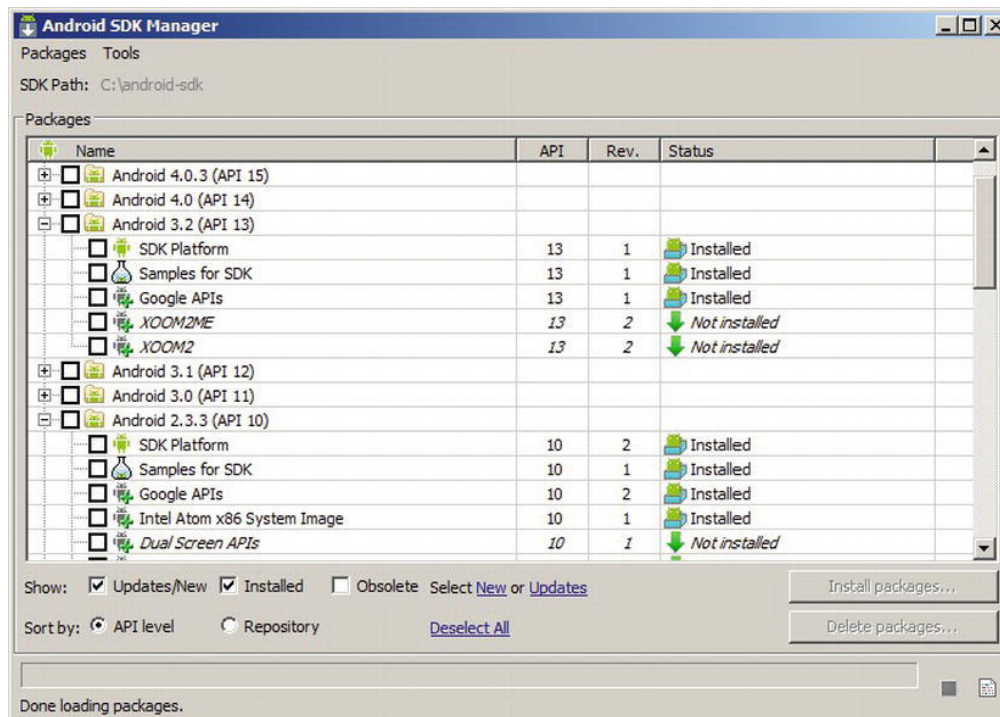

Figure 15-8. The Android SDK Manager

want to develop and test applications for Android tablets, choose and install an API 3.x or above. Older Android versions such as API 2.2 and API 2.3 are an appropriate choice for targeting smaller devices such as smart phones.

Once you have the appropriate Android APIs installed, you need to configure the Android virtual machines you want to target and test with.

This you can do by creating an Android Virtual Device using the Manage AVDs link in the Tools menu in the SDK Manager, or the separate AVD Manager tool installed with Android SDK. We recommend that you create an Android 2.3 and an Android 3.2 virtual device for the sample in this section, so you can test it on various formats such as smart phones and tablets.

Go ahead and click New... in the AVD Manager and create these new AVDs: an example configuration for Android 2.3 is shown in Figure 15-9. The Target dropdown is populated based on the APIs you have installed on your system. For each API, you can choose between various built-in skins that are available, or specify a custom resolution for your device. The Hardware section lists various properties for your device. Figure 15-9 contains a few properties that enable, among others, GPS support on the emulated device. You should consult the Android SDK documentation for a more in-depth treatment of communicating “hardcoded” settings such as your current location into your virtual devices, or interacting with them on the fly in various other ways.

A couple useful tools that you should be aware of while developing Android applications:

- `adb.exe` (in `%ANDROID_HOME%\platform-tools`) – the Android Debug Bridge. This is the tool/server that enables you to interact with a physical Android device connected to your machine in USB debug mode, or with a running virtual device. Running it without parameters will display a long list of options and parameters that control different aspects of communicating with the connected Android device. A few important commands are:
  - `adb.exe install <apk-package>` – installs the given `.apk` package. In general, this is the easiest and quickest way to install your WebSharper-generated `.apk` to your emulator or to your connected physical device.
  - `adb.exe uninstall <apk-package>` – uninstalls the given `.apk` package. Alternatively, you can also uninstall a package in the emulator itself via Settings \ Applications.
  - `adb.exe kill-server` – attempts to kill the Android Debug Bridge server and might be necessary if your device is not detected.
  - `adb.exe start-server` – attempts to start the Android Debug Bridge server on a given port and might be necessary if your device is not detected.
- `telnet.exe` (in `%SystemRoot%\System32`) – your old friend from the past, a client tool that enables you to communicate with the Android Debug Bridge using the Telnet communication protocol. Telnet can be installed via the system Control Panel, under Programs and Features, by turning on the Telnet feature. In general, you invoke it as `telnet.exe localhost <port>`, where `<port>` is the port number your Android Debug Bridge server is listening on.

Once you have successfully connected to the Android bridge server, you can issue various commands. For instance, you can hardcode the GPS coordinates to the connected Android device with the following command:

```
geo fix <long> <lat>
```

Here, `<lat>` and `<long>` are the latitude and longitude values, respectively.

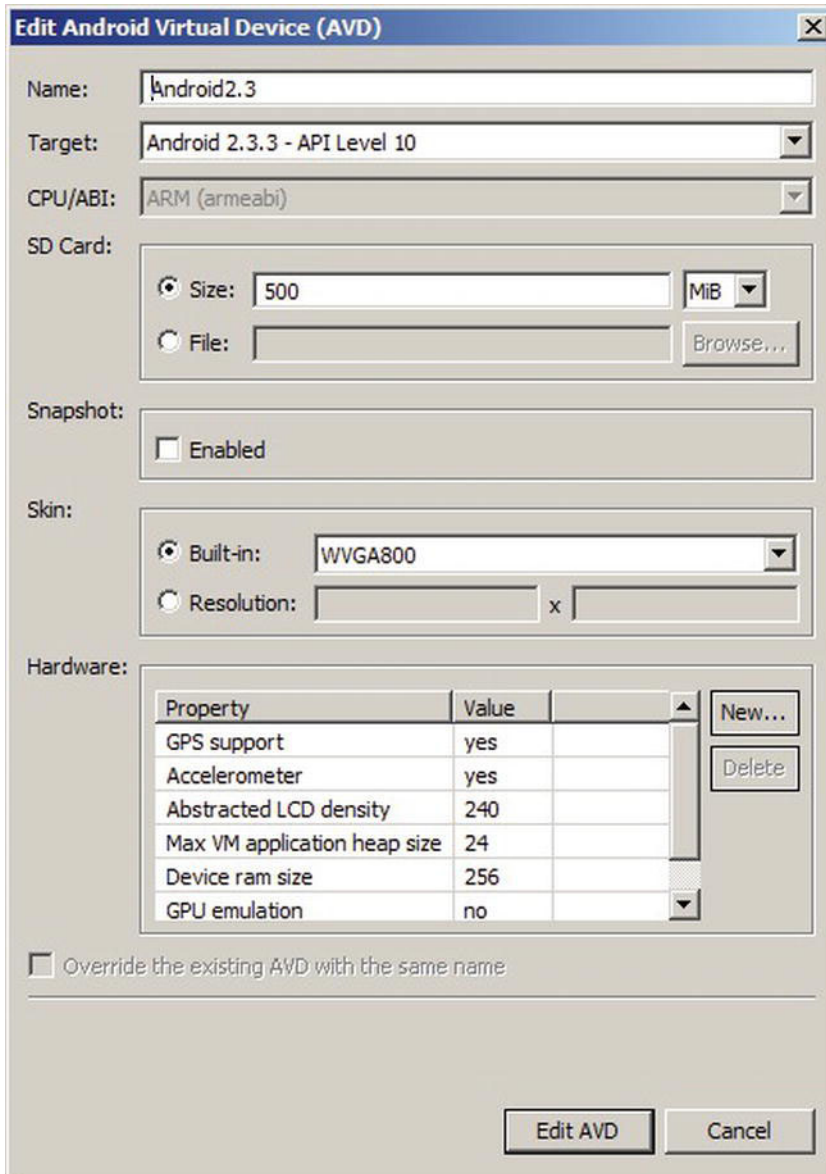

Figure 15-9. Configuring an Android virtual device

## Using the Android Application Visual Studio Template

Now that you are familiar with installing different Android APIs and setting up virtual devices running those APIs, you can get started on your native Android application. First, choose the Android Application template in Visual Studio and create your new project. This template provides the necessary tooling to distill a set of JavaScript files and other artifacts from your application, and to package them into a native Android application, a technique employed by other popular tools like PhoneGap (<http://phonegap.com>).

PhoneGap provides packaging for several mobile platforms, including Android, Windows Phone, iOS, Blackberry, Bada, and others, and can be used in conjunction with WebSharper offline sitelets to package your WebSharper applications for any of these mobile platforms. You may want to use PhoneGap for packaging WebSharper applications for iOS, such as the ones you saw in earlier sections in this chapter, as iOS is not yet supported as a target native application format in WebSharper Mobile. Nonetheless, WebSharper Mobile provides a hassle-free packaging experience for Android and Windows Phone applications and is tightly coupled with WebSharper.

The Android Application template you used to create your application from contains an `android` folder with files that are related to packaging your final Android application. In particular, the `.project` file in the root of this folder contains the name of your Android package, set by default to `DroidSite`. You may want to rename this according to your needs later on.

Another important artifact in the `android` folder is `ant.properties`, a configuration file used in conjunction with building with `ant`. This file contains your signature settings for signing the resulting packages. By default, these settings are not configured and your application packages are unsigned. Therefore, before distributing your packages, you should generate a key store using the `keytool.exe` tool in your JDK, and configure `ant.properties` accordingly.

Building via `ant` is the preferred way of building Android packages, as the `msbuild` script shipped with the Android Application WebSharper template will trigger `ant` as part of the build process to bundle the final Android package automatically. Your resulting Android package will be under `android\bin`, whereas the distilled HTML+JavaScript code along with any additional artifacts that were packaged will be copied under `android\assets` to make it easier to investigate them offline.

## Implementing Your Native Android Application

Other than the `android` folder you saw in the previous section, your empty Android application project has the same two files you saw in previous sections: `Main.fs` for your application code, and `Main.html` for your dynamic template markup. The latter is shown in Listing 15-7, and it may look quite familiar to you since it contains a barebones mobile-aware markup you used in other examples in this chapter.

*Listing 15-7. Main.html – Defining the Dynamic Template for the Android Application*

```
<!DOCTYPE html>
<html>
  <head>
    <title>Your Android Application</title>
    <meta name="viewport" content="width=device-width, initial-scale=1" />
    <meta name="generator" content="websharper" data-replace="scripts" />
  </head>
  <body>
    <div data-hole="body" />
  </body>
</html>
```

The main application code is shown in Listing 15-8. The code uses the jQuery Mobile formlets extension (which depends on the jQuery Mobile extension) and the Bing Maps extension, so you need to download and install WebSharper Extensions for jQuery Mobile, Formlets for jQuery Mobile, and Bing Maps, respectively, from the WebSharper download site (<http://websharper.com/downloads>), and add references to `IntelliFactory.WebSharper.JQuery.Mobile`, `IntelliFactory.WebSharper.Formlets`, `JQueryMobile`, `IntelliFactory.WebSharper.Bing`, and `IntelliFactory.WebSharper.Bing.Rest` from the folders you installed them into.

*Listing 15-8. Main.fs—Implementing your Android Application*

```

namespace MyApplication

open IntelliFactory.WebSharper
open IntelliFactory.WebSharper.Sitelets

module MySite =
    type Action = | Home

    module Skin =
        open System.IO

        type Page =
            {
                Body : list<Content.HtmlElement>
            }

        let MainTemplate =
            let path = Path.Combine(__SOURCE_DIRECTORY__, "Main.html")
            Content.Template<Page>(path)
                .With("body", fun x -> x.Body)

        let WithTemplate body : Content<Action> =
            Content.WithTemplate MainTemplate <| fun context ->
                {
                    Body = body context
                }

    module Client =
        open IntelliFactory.WebSharper.Html
        open IntelliFactory.WebSharper.Bing
        open IntelliFactory.WebSharper.JQuery
        open IntelliFactory.WebSharper.JQuery.Mobile
        open IntelliFactory.WebSharper.Formlet
        open IntelliFactory.WebSharper.Formlets.JQueryMobile

        [<JavaScript>]
        let BingMapsKey = "<put-your-bing-maps-key-here>"

        [<JavaScript>]
        let ShowMap () =
            let screenWidth = JQuery.Of("body").Width()
            let MapOptions = Bing.MapViewOptions(
                Credentials = BingMapsKey,
                Width = screenWidth - 20,
                Height = screenWidth - 40,
                Zoom = 16)

            let label = Span []
            let setMap (map : Bing.Map) =
                let updateLocation() =

```

```

// Gets the current location
match Android.Context.Get() with
| Some ctx ->
    if ctx.Geolocator.IsSome then
        async {
            let! loc = ctx.Geolocator.Value.GetLocation()
            // Sets the label to be the address of
            // the current location.
            Rest.RequestLocationByPoint(
                BingMapsKey,
                loc.Latitude, loc.Longitude, ["Address"],
                fun result ->
                    let locInfo = result.ResourceSets.[0].Resources.[0]
                    label.Text <-
                        "You are currently at " +
                        JavaScript.Get "name" locInfo
            // Sets the map at the current location.
            let loc =
                Bing.Location(loc.Latitude, loc.Longitude)
            let pin = Bing.Pushpin loc
            map.Entities.Clear()
            map.Entities.Push pin
            map.SetView(Bing.ViewOptions(Center = loc))
        }
    |> Async.Start
else
    ()
| None ->
    ()
JavaScript.SetInterval updateLocation 1000 |> ignore
let map =
    Div []
    |>! OnAfterRender (fun this ->
        let map = Bing.Map(this.Body, MapOptions)
        map.SetMapType(Bing.MapTypeId.Road)
        setMap map)
Div [
    label
    Br []
    map
]

[<JavaScript>]
let LoginSequence () =
    Formlet.Do {
        let! username, password =
            Formlet.Yield (fun user pass -> user, pass)
        <*> (Controls.TextField "" Enums.Theme.C
            |> Enhance.WithTextLabel "Username"
            |> Validator.IsNotEmpty "Username cannot be empty!")
        <*> (Controls.Password "" Enums.Theme.C

```

```

        |> Enhance.WithTextLabel "Password: "
        |> Validator.IsRegexMatch "^[1-4]{4,}[5-9]$"
            "The password is wrong!")
    |> Enhance.WithSubmitButton "Log in" Enums.Theme.C
do! Formlet.OfElement (fun _ ->
    Div [
        H3 [Text ("Welcome " + username + "!")]
        ShowMap()
    ])
}
|> Formlet.Flowlet

type ApplicationControl() =
    inherit Web.Control()

    [<JavaScript>]
    override this.Body =
        Div [LoginSequence ()] :> _

module Pages =
    open IntelliFactory.Html

    let Home =
        Skin.WithTemplate <| fun ctx ->
            [
                Div [
                    HTML5.Data "role" "page"
                    Id "main"
                    HTML5.Data "url" "main"
                ] -< [
                    new Client.ApplicationControl()
                ]
            ]

type MyWebsite() =
    interface IWebsite<Action> with
        member this.Sitelet =
            Sitelet.Content "/index" Action.Home Pages.Home
        member this.Actions = [ Action.Home ]

[<assembly: Website(typeof<MySite.MyWebsite>)>]
do ()

```

In order to be able to run your application, you need to configure your own Bing Maps key in `Client.BingMapsKey`. To obtain such a key, you should consult the Bing Maps home page. This key enables you to make programmatic queries to the Bing Maps service, such calling the various REST APIs provided by WebSharper Extensions for Bing Maps.

The main part of the application is in the `Client` module. There are two distinct components: one for showing a map marked with the user's current GPS location, and another for displaying a login form that "authenticates" the current user to see this map. The main "application" control, defined with the



ApplicationControl server control type, simply exposes this login formlet, which then in turn invokes the map if the user passed the authentication step.

The ShowMap() function creates a <div> node, with a label and the map component. The map itself is embedded in a nested <div> node, with an event handler firing once the corresponding DOM node has been inserted into and rendered in the document the user sees:

```
let map =
  Div [
    |>! OnAfterRender (fun this ->
      let map = Bing.Map(this.Body, MapOptions)
      map.SetMapType(Bing.MapTypeId.Road)
      setMap map)
  ]
...

```

This code creates a Bing Map control with the options defined in MapOptions, sets its map type to road map, and calls setMap on it. In turn, setMap defines an update function updateLocation and registers it to fire every second using the JavaScript.SetInterval function. The heart of the map functionality, updateLocation retrieves the GPS geo-locator object from the Android context (if either is missing, it does nothing – here, you may want to add some fallback logic yourself to make the application testable on plain non-mobile browsers, etc.), and uses this object to retrieve the device's current GPS coordinates, then queries the Bing Maps service to map those to an actual street name, and displays that in the label component along with a pushpin on the map itself.

The formlet code is even more intuitive. Take a look at the partial snippet below:

```
Formlet.Do {
  let! username, password =
    Formlet.Yield (fun user pass -> user, pass)
  <*> <... formlet-1 ...>
  <*> <... formlet-2 ...>
  |> Enhance.WithSubmitButton "Log in" Enums.Theme.C
  do! Formlet.OfElement (fun _ ->
    Div [
      H3 [Text ("Welcome " + username + "!")]
      ShowMap()
    ]
  )
}
|> Formlet.Flowlet

```

Here, “formlet-1” and “formlet-2” declare two input boxes, enhanced with a label and a validator to input the user name and the password strings from the user. Note that these validators require that the user enters a non-empty user name, and a password that contains at least four digits between 1 and 4 followed by a digit between 5 and 9, for instance, “12345”. These input boxes are then composed into a single formlet, returning a (username, password) tuple, and enhanced with a submit button. Here, all three functions Controls.TextField, Controls.Password, and Enhance.WithSubmitButton are from the IntelliFactory.WebSharper.Formlets.JQueryMobile namespace, and implement their functionality using jQuery Mobile look and feel.

The username/password formlet is enhanced as a flowlet; e.g., its individual formlet steps (marked with let!) are executed in a sequential wizard-style presentation, one following the other. In your formlet example above, once the user enters a username/password pair and successfully passes the validations after pressing the Submit button, control transfers to the do! block, which responds by welcoming the newly signed-in user and showing the Bing Map control defined in ShowMap.

## Summary

This chapter gave you a short introduction to developing web and native mobile applications with WebSharper. You saw how a new breed of mobile applications is emerging, utilizing HTML5 and CSS3; how you can output this sort of mobile HTML5 markup from WebSharper sitelets; apply various feature detection and polyfilling libraries to get over missing browser features; and develop iOS mobile web applications that use easy-to-embed, Safari-specific markup instructions to mimic some of the features of native mobile applications, such as the ability to use the entire screen or adding web applications as icons to the desktop. In the latter half of the chapter, you also saw how you can develop WebSharper extensions to third-party JavaScript APIs and use these extensions in a mobile web application to display a user's Facebook status updates with jQuery Mobile-based list views, giving an elegant mobile look to your application. And last, you saw how you can combine the expressiveness of WebSharper formlets with mobile UI controls to build declarative, composable, type-safe mobile user interfaces and apply them in an application that uses Bing Maps to show your location.

All in all, you learned that the functional concepts such as formlets and sitelets that WebSharper enables yield a powerful device that you can employ to develop mobile web applications, and together with WebSharper Mobile, package them into native application packages for Android and Windows Phone, or use third-party packaging technologies such as PhoneGap (<http://phonegap.com>) to cover alternate platforms. At this point, you have keen eyes on upcoming HTML5 support of various mobile features, and recognize that it is only a short time away until mobile browser features are unified in further HTML5 standards to bring uniformity into developing for touch-based mobile devices.

## CHAPTER 16



# Visualization and Graphical User Interfaces

GUI applications revolve around events, and F# provides a natural way to process events with functions. Graphical interfaces are often developed using visual editors, in particular to build GUIs by assembling *controls*. Applications, however, often need drawing capabilities for displaying and manipulating data, which requires custom programming to augment available controls. This chapter discusses how to develop graphical applications with F# and why the functional traits of the language suit the event-driven programming paradigm typical of GUIs.

In this chapter, you use the Windows Forms library. The Windows Presentation Foundation (WPF) is the presentation framework for the Windows, Silverlight, and Windows Phone platforms; it's discussed later in this chapter. You may wonder why it's useful to know about the old-fashioned Windows Forms toolkit. The answer is twofold: on one hand, the framework structure is shaped after a consolidated model that dominated graphical programming for decades and is still used in many other frameworks for programming GUIs, such as GTK#, a managed library for writing applications based on the GTK toolkit.

## Writing “Hello, World!” in a Click

It's traditional to start with a “Hello, World!” application, so let's honor that and begin with a simple program that provides a button to display the magic phrase when clicked:

```
open System.Windows.Forms

let form = new Form(Text = "Hello World WinForms")
let button = new Button(Text = "Click Me!", Dock = DockStyle.Fill)

button.Click.Add(fun _ -> MessageBox.Show("Hello, World!", "Hey!") |> ignore)
form.Controls.Add(button)
form.Show()
```

Even in its simplicity, the application captures many traits typical of GUI applications. After opening the namespace associated with Windows Forms, you create the form `form` that contains the button `button`, set the form and button captions by assigning their `Text` properties, and tell the button that it should fill the entire form.

Most GUI programming is devoted to handling events through callbacks from the graphical interface. Events are described in Chapter 11. To display a message box containing the "Hello, World!" string, you have to configure the button so that when its Click event is fired, a function is called. In the example, you pass a function to the Add method for the button's Click event, which adds an event handler to an event source. You then add the button to the form and call the form's Show method to display it.

Note that this code should be executed using `fsi.exe`. It won't run as a stand-alone application unless you add the following line at the end:

```
Application.Run(form)
```

This line relates to the *event loop* of a GUI application, and it's required to handle events such as button clicks. Moreover, if you execute the compiled program, notice that the window uses the classic Windows look and feel rather than the more fashionable look and feels featured by Windows versions since Windows XP. This can be easily addressed by adding the following call to the `EnableVisualStyles` static method, right after the open statement:

```
Application.EnableVisualStyles()
```

If you use `fsi.exe`, both visual styles and the event loop are handled by F# Interactive.

## Understanding the Anatomy of a Graphical Application

Graphical applications are built on the abstractions provided by the graphical environment hosting them. The application must interact with its environment and process input in an unstructured way. User input isn't the only kind of input received from a windowing system. Window management often involves requests to or from the application itself, such as painting or erasing a form.

Windowing systems provide a common and abstract way to interact with a graphical application: the notion of an *event*. When an event occurs, the application receives a message in the *message queue* with information about the event.

The graphical application is responsible for delivering messages from the message queue to the control for which they're meant. A set of functions provided by the API of the windowing system supports this. This activity of reading messages from the message queue and dispatching them is known as the *event loop* of the application. If the loop fails for any reason, the GUI components cease to work, the application hangs, and Windows may eventually inform you that the application isn't responding.

It's rare for an application to program the event loop explicitly. Programming toolkits encapsulate this functionality, because it's basically always the same. The `Run` method of the `Application` class is responsible for handling the event loop, and it ensures that messages related to events are delivered to targets within the application.

GUI programs often involve multiple *threads* of execution. Chapter 11 discusses threading and concurrency in more detail; for this chapter, it's important to remember that event dispatching is a single-threaded activity, even if it may seem to be the opposite. The thread executing the event loop calls the functions and methods registered for handling the various events. In the "Hello, World!" example, for instance, you told the button to call back the function to show the message box when clicked.

---

### AN EXPLICIT EVENT LOOP

---

A Windows Forms event loop can also be explicitly defined by the application using the `Application.DoEvents` method; in this case, each invocation performs a step in event handling and returns the control to the caller. Some programs can benefit from this control, because they can interleave event processing and computation using a single thread. Computer games, for instance, tend to use this approach, because event-based timers provided by the framework aren't reliable for producing the frames of the game at the required pace. The following is a typical explicit event loop:

```
let form = new Form(Text = "Explicit Event Loop")
form.Show()
while form.Created do
    // Perform some task
    Application.DoEvents()
```

When events are handled explicitly, a program must call the `DoEvents` method frequently: if events aren't processed, the graphical interface may become unresponsive, which provides the wrong feedback to the user.

---

Software reuse has always been a priority in the world of graphical applications, because of the many details involved in realizing even simple behaviors. It's not surprising that programming techniques favoring software reuse have always flourished in this context. You can develop a GUI application without writing a single line of code by combining existing controls into a new interface.

Articulated frameworks, such as Windows Forms, provide a significant number of reusable controls so that you can develop entire applications without needing to use drawing facilities provided by the interface. For this reason, frameworks have started to support two kinds of customers: those composing interfaces with controls and those who need to develop new controls or explicitly use drawing primitives. The following sections explore the Windows Forms framework from both perspectives: the functional nature of F# is very effective for using controls, and the ability to define objects helps you to develop new ones.

## Composing User Interfaces

A control is represented by an object inheriting, either directly or indirectly, from the `Control` class in the `System.Windows.Forms` namespace. Building interfaces using controls involves two tasks: placing controls into containers (that are themselves a particular type of control) such as panels or forms, and registering controls with event handlers to be notified of relevant events.

As an example, let's develop a simple Web browser based on the Internet Explorer control, which is a control that allows wrapping the HTML renderer (the interior of an Internet Explorer window) into an application. This example shows how to develop the application interactively using `fsi.exe`. Start by opening the libraries required for using Windows Forms:

```
open System
open System.Drawing
open System.Windows.Forms
```

Then, enable the Windows visual styles, declaring through the custom attribute `STAThread` that the application adopts the *single thread apartment model*, which is a COM legacy often required for Windows Forms applications to interact with COM components:

```
[<STAThread>]
do Application.EnableVisualStyles()
```

You need this in the example because Internet Explorer is a COM component accessible through a .NET wrapped type named `WebBrowser` in the `System.Windows.Forms` namespace, as are all the base controls offered by Windows Forms (assume that types are from this namespace unless otherwise specified).

Now you have to decide what the browser application should look like (see Figure 16-1). The bare minimum is a toolbar featuring the address bar and the classic Go button, a status bar with a progress bar shown during page loading, and the browser control in the middle of the form.

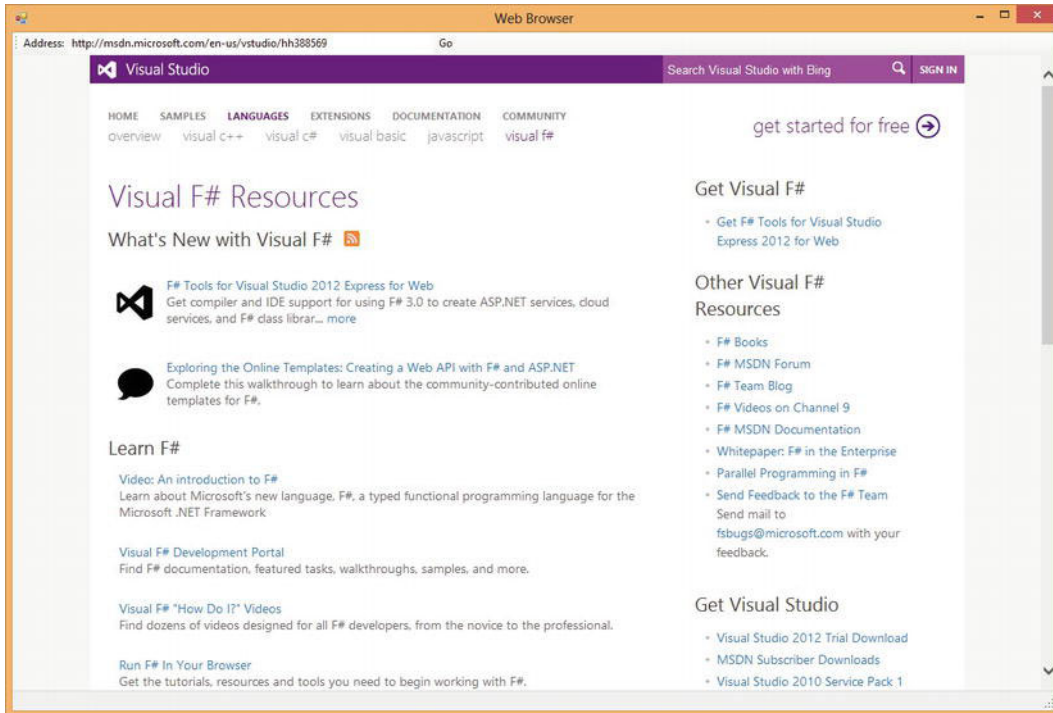

Figure 16-1. A simple Web browser application

Next, configure the elements, starting from the status bar, as shown in the following code. Add the progress bar to the status bar and configure both. The Dock property of the status bar is set to Bottom, meaning that the status bar should fill the bottom part of the form. The progress bar is resized, and then its Style property is set to Marquee, meaning that you don't want to show any specific progress but just something moving during download:

```
let statusProgress =
    new ToolStripProgressBar(Size = new Size(200, 16),
                           Style = ProgressBarStyle.Marquee,
                           Visible = false)
let status = new StatusStrip(Dock = DockStyle.Bottom)
status.Items.Add(statusProgress) |> ignore
```

You can now set up the browser's toolbar, as shown in the following code. The toolbar should be in the top area of the form, so set its Dock property to Top. First add a label, the text box for typing the URL, and the button. Then, stretch the address text box and associate an event handler with its KeyPress event. This way, you can catch the Enter key and start browsing the typed URL without having to wait for the Go button. Finally, configure the Go button by setting its label and associating an event handler with the Click event:

```
let toolbar = new ToolStrip(Dock = DockStyle.Top)
let address = new ToolStripTextBox(Size = new Size(400, 25))
let browser = new WebBrowser(Dock = DockStyle.Fill)
let go = new ToolStripButton(DisplayStyle = ToolStripItemDisplayStyle.Text,
```

```

        Text = "Go")
address.KeyPress.Add(fun arg ->
    if (arg.KeyChar = '\r') then browser.Url <- new Uri(address.Text))
go.Click.Add(fun arg -> browser.Url <- new Uri(address.Text))
toolbar.Items.Add(new ToolStripLabel("Address:")) |> ignore
toolbar.Items.Add(address) |> ignore
toolbar.Items.Add(go) |> ignore

```

Both event handlers set the `Url` property of the browser object, causing the `WebBrowser` control to load the given `Uri`. Notice how nicely and compactly F# lets you specify event handlers. This is possible because F# lets you use functions directly as arguments to `Add`.

You can now take care of the browser control and set its properties. Tell the browser to occupy all of the remaining area in the form left over after the toolbar and the status bar are docked, by setting the `Dock` property to `Fill`. Then subscribe to two events, `Navigating` and `DocumentCompleted`, in order to be notified by the browser when document loading starts and completes. When the browser begins fetching a URL, you show the progress bar in the status bar, setting its `Visible` property to `true`. After the document is loaded, hide the progress bar, and update the address bar so that if the user follows a link, the address shown remains consistent with the current document:

```

browser.Navigating.Add(fun args ->
    statusProgress.Visible <- true)
browser.DocumentCompleted.Add(fun args ->
    statusProgress.Visible <- false;
    address.Text <- browser.Url.AbsoluteUri)

```

You're almost finished with the interface. You have to tell Windows Forms that the controls are contained in the form `form`. Then, configure the form by setting its caption with the `Text` property and its size with the `Size` property. You call `PerformLayout` to update the current layout of the form, and then you can call `Show` to display the browser:

```

let form = new Form(Text = "Web Browser", Size = new Size(800, 600))
form.Controls.Add(browser)
form.Controls.Add(toolbar)
form.Controls.Add(status)
form.PerformLayout()
form.Show()

```

To compile the application rather than execute it interactively, add the following at the end, as mentioned previously:

```
Application.Run(form)
```

---

## WATCH THE APPLICATION GROW

---

You can see the form growing interactively using `fsi.exe`. Usually, applications first configure forms and controls and then call `Show` to present the user with a form that's ready to use. It's also useful to set the properties `TopMost=true` and `Visible=true`. The properties of a form can also be set after the form is visible, allowing you to see the effects of each operation on it. F# Interactive offers the unique opportunity to watch the form growing interactively; you can, for instance, build the interface of the simple Web browser by showing the form immediately and then proceed to add controls and set their properties. Thus, you can experiment with the various properties of controls and see how they affect the interface.

---

What have you learned by developing this application? It's clear that building interfaces based on controls requires a significant amount of code to configure controls by setting their properties. The form's layout is also set by defining properties of controls, as you did in the browser. Moreover, an ever-increasing number of controls are available, and each provides a large number of properties. F# syntax supports this process by letting you set initial values for control properties within the call to the control constructor, and adding functions as event handlers, leading to very compact programs that are easier to understand.

---

## CONTROL LAYOUT

---

The layout of controls, done either by hand or through a visual editor, defines how a form looks when it is opened. Users expect that the layout will adapt gracefully to form resizing. One simple approach to the problem is to forbid the resizing operation, as is done in many dialog boxes; a better solution is to define how controls must adapt their positions and sizes as the form changes size.

Windows Forms has two ways to indicate how a control should adapt when the size of its container changes. You can use the property `Dock` to *dock* the control to one of the four edges or to the center of the container (as shown in Figure 16-2). Docking to the edges constrains the control to be always attached to one of them, and either its width or its height should change in order to ensure that the whole edge is filled with it (as shown in Figure 16-2, horizontal edges have precedence over vertical ones). When docked to the middle, a control is resized to fill the area of the container left over or not occupied by the controls docked to the edges. Docking is a flexible way to define layouts that adapt to size changes of the user interface. If the five areas defined by this strategy aren't enough, you can rely on logical containers such as panels: a panel represents a group of controls with a given layout. Using panels, you can nest layouts and use docking on a panel docked in the surrounding container.

An alternative to docking is *anchoring*. Through the property `Anchor`, you can dictate that the distance between an edge of the control and the corresponding edge of the container should be constant. This gives you finer control over how the component should be resized or moved. When a control is anchored only to a horizontal and vertical edge (for instance `Top` and `Left`), its size and offsets from the anchored edges don't change.

Although docking and anchoring are useful for controlling how the control must be adapted to the interface, sometimes these strategies aren't enough to address the needs of a complex layout. The WPF adopts a more articulated notion of extensible layout management based on the notion of a layout manager (a similar notion has always been present in Java AWT and in HTML).

---

*Visual designers* are graphical applications that allow you to design interfaces using a visual metaphor. Controls are dragged and dropped onto forms and then configured through a property window. Visual Studio provides a visual designer, although it isn't available for all programming languages. The F# project system doesn't feature visual design of GUIs within Visual Studio for Windows Forms or for WPF frameworks. Using the Visual Studio designer is still a useful way to explore controls and to play with their properties, however, and the generated C# fragments can be examined and used in F# code. To understand how the Visual Studio designer works, let's design the same browser application in C#, as shown in Figure 16-2. The Visual Studio designer generates, for the form `Browser`, a C# file named `Browser.Designer.cs` containing all the C# code required to set up the interface. If you look at that file, you can see that it contains mainly the assignments of control properties similar to those you manually used to prepare the browser form.



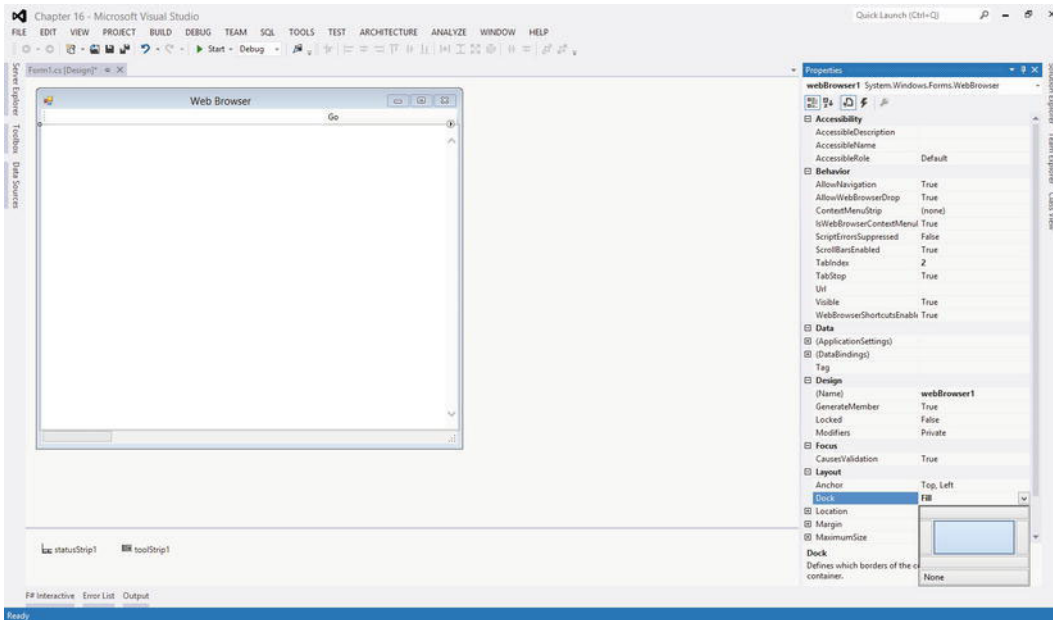

Figure 16-2. The Visual Studio form designer

Without a visual designer for F#, there are essentially four options for building graphical interfaces in the language:

- Write the interface code by hand, as you did for the browser sample.
- Develop a visual designer that outputs F# code (although it's a hard job), and use it.
- Use the C# visual designer, and then convert the assignments in `file.Designer.cs` into F#.
- Exploit the interoperability of the .NET platform by designing the interface with the designer, generating C# or another supported language and using the F# code as a library.

Leverage on existing designers and .NET interoperability suits many graphical applications scenarios, allowing programmers to exploit the F# data-processing expressivity and power to fuel the UI created using productivity tools. You can easily define simple interfaces with F# code, however, and the rest of this chapter shows you how to do so. You now focus on the more important part of designing graphical applications: drawing and control development.

## Drawing Applications

So far, you've developed graphical applications based on the composition of predeveloped graphical controls, but what do you do if no graphical control suits your needs? You need to learn how to draw using the drawing primitives provided by the graphical system.

To understand how drawing works, you need to review the model behind the rendering process of a graphical application. This model really distinguishes Windows Forms from WPF; later, this chapter

reviews the traditional paint-based model that still dominates the presentation systems panorama. You know already that the event-driven programming paradigm best suits graphical applications; so far, you've associated event handlers with user actions, but events are used by the graphical system as a general mechanism to communicate with the graphical application.

An application uses resources provided by the graphical system, and these resources are mostly windows. A *window* is a rectangular area on the screen, not necessarily a top-level window with buttons, a title bar, and all the amenities you usually associate with it. Windows can be nested, and they are the unit of traditional windowing systems. Windows can contain other windows, and the windowing system is responsible for ensuring that events are routed to the callbacks registered for handling the events for each window.

Windows are allowed to draw in their own client areas, and the drawing is performed through the *device context*, an object provided by the graphical system and used to perform the *graphic primitives* to draw the content. The graphic primitives issued to the graphics system aren't retained by it; therefore, when the window is covered for some reason, the portion that becomes hidden must be repainted when it's uncovered. Because the information required to redraw the hidden portion is held by the application owning the window, the graphical system sends a *paint* message to the window.

To better understand the drawing model, consider a simple graphical application that shows how to draw a curved line using the Bézier curve and canonical splines, given four control points. Start by opening your namespaces and telling Windows Forms that your form can use the current Windows look rather than the classic Windows 95 style; also, set a global flag to tell standard controls to use the new GDI+ text-rendering primitives rather than those of the traditional GDI (this code is omitted from now on, but remember to use it later; also, remember that this must be done before windows are created—otherwise, an exception is thrown):

```
open System
open System.Drawing
open System.Windows.Forms
```

```
Application.EnableVisualStyles()
Application.SetCompatibleTextRenderingDefault(false)
```

Next, create the form and define the initial values of the control points. The `movingPoint` variable keeps track of the point the user is dragging, to adjust the curve:

```
let form = new Form(Text = "Curves")
let cpt = [|Point(20, 60); Point(40, 50); Point(130, 60); Point(200, 200)|]
let mutable movingPoint = -1
```

Let's introduce three menus to configure the application. They're used to check features to be drawn:

```
let newMenu (s : string) = new ToolStripMenuItem(s, Checked = true, CheckOnClick = true)
let menuBezier = newMenu "Show &Bézier"
let menuCanonical = newMenu "Show &Canonical spline"
let menuControlPoints = newMenu "Show control &points"
```

Use a scrollbar to define different values for the tension parameter of the canonical spline curve:

```
let scrollbar = new VScrollBar(Dock = DockStyle.Right, LargeChange = 2, Maximum = 10)
```

Control points are drawn if required, and an ellipse is used to mark each of them. The function receives the device context in the form of a `Graphics` object; draw the ellipse by invoking the `DrawEllipse` primitive on it. Use a `Pen` to draw the ellipse—in this case, a red pen:

```
let drawPoint (g : Graphics) (p : Point) =
    g.DrawEllipse(Pens.Red, p.X - 2, p.Y - 2, 4, 4)
```

---

## BRUSHES AND PENS

---

Windows Forms uses two kinds of objects to define colored primitives: brushes and pens. A *brush* is used to fill an area with a given pattern. A number of different patterns are available; solid colors are provided by the `SolidBrush` class, hatched patterns are provided by `HatchBrush`, gradients are provided by `LinearGradientBrush` and `PathGradientBrush`, and textured gradients are provided by `TextureBrush`. The `Brushes` class provides a number of static brush objects describing solid colors.

*Pens* are brushes with a contour. The line drawn by a pen has a filling (the brush part) but also a width and different styles (dashed or not, with different caps at the beginning and at the end). The `Pens` class provides a number of static pen objects with the basic solid colors.

Both pen and brush objects contain resources of the graphical system; it's important to dispose of them as soon as they aren't required anymore. A `using` binding or the `using` function discussed in Chapters 4 and 8 helps ensure that you don't forget to call the `Dispose` method that all these objects provide from the `IDisposable` interface that otherwise should be called explicitly.

---

You're now ready to define the function responsible for drawing in your window. You can't assume anything about the current state of the window; thus, the `paint` function always draws the visible primitives<sup>1</sup> depending on the state of menu entries:

```
let paint (g : Graphics) =
    if (menuBezier.Checked) then
        g.DrawLine(Pens.Red, cpt.[0], cpt.[1])
        g.DrawLine(Pens.Red, cpt.[2], cpt.[3])
        g.DrawBeziers(Pens.Black, cpt)
    if (menuCanonical.Checked) then
        g.DrawCurve(Pens.Blue, cpt, float32 scrollbar.Value)
    if (menuControlPoints.Checked) then
        for i = 0 to cpt.Length - 1 do
            drawPoint g cpt.[i]
```

Figure 16-3 shows the result of the drawing all the elements. The Bézier curve, widely used in image-processing and vector applications, uses the four control points to define the start and end points of the curve and the two segments tangent to the curve at its ends. The cubic parametric curve is calculated from these points and produces the lines shown in Figure 16-3. The canonical spline, on the other hand, is a curve that traverses all the control points; the tension parameter controls how curvy the curve is.

You now want to allow users to move control points by dragging and dropping. You're interested in mouse events—in particular, when the mouse button is pressed, when it moves, and when the button is released. Thanks to the well-defined model for rendering the application, you can update the state of your variables and ask the graphical system to issue a `paint` message that causes the window to receive a `paint` message and update the current frame.

---

<sup>1</sup>If primitives fall out of the area allowed for drawing, they're clipped in part or entirely.

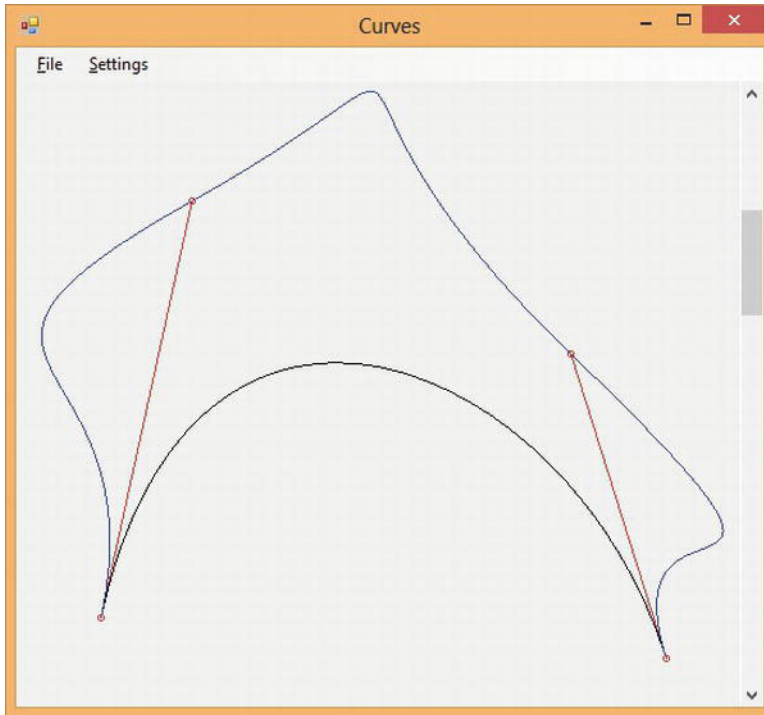

Figure 16-3. Output of the Curves application

---

## BACKGROUND PAINTING

---

In the Curves application, you draw assuming that the window is clean—but who is responsible for clearing the previous drawing in the window? Windows Forms calls the `OnPaintBackground` method before calling the paint handler, and this method by default clears the area with the color returned by the `BackColor` property. When the function responsible for painting draws the area entirely, painting the background could be useless and even problematic: the quick repaint may flicker because the eye can perceive the background as clear and then the drawing of the current frame. You can use the `SetStyle` method of the `Form` class to configure the application to do all the paint operations in the handler of the paint event, and you can override `OnPaintBackground` to an empty method to avoid this effect.

You define a helper function to define a circular area around a point that is sensible to your interaction. This is required in order to not require the user to pick the exact pixel corresponding to the control point:

```
let isClose (p : Point) (l : Point) =
    let dx = p.X - l.X
    let dy = p.Y - l.Y
    (dx * dx + dy * dy) < 6
```

When the mouse button is pressed, you check whether the click is over any control point. In this case, you store its index in the `movingPoint` variable; otherwise, the event is ignored:

```
let mouseDown (p : Point) =
    try
        let idx = cpt |> Array.findIndex (isClose p)
        movingPoint <- idx
    with _ -> ()
```

When the mouse moves over the client area of the window, the mouse move event is generated. If the `movingPoint` member has a value other than `-1`, you have to update the corresponding control point with the current position of the mouse defined by the variable `p`:

```
let mouseMove (p : Point) =
    if (movingPoint <> -1) then
        cpt.[movingPoint] <- p
        form.Invalidate()
```

Next, define for the window a File menu and a Settings submenu. The first features the classic Exit option, and the second shows the three checked menu items that control what the paint method should draw. You define menus by composing objects that correspond to the various menu entries. You also define the event handlers associated with each menu item. When Exit is clicked, the `form` is disposed. In all the other cases, you rely on the menu item's ability to change its checked state, and you invalidate the form content to force the redraw of the window:

```
let setupMenu () =
    let menu = new MenuStrip()
    let fileMenuItem = new ToolStripMenuItem("&File")
    let settMenuItem = new ToolStripMenuItem("&Settings")
    let exitMenuItem = new ToolStripMenuItem("&Exit")
    menu.Items.Add(fileMenuItem) |> ignore
    menu.Items.Add(settMenuItem) |> ignore
    fileMenuItem.DropDownItems.Add(exitMenuItem) |> ignore
    settMenuItem.DropDownItems.Add(menuBezier) |> ignore
    settMenuItem.DropDownItems.Add(menuCanonical) |> ignore
    settMenuItem.DropDownItems.Add(menuControlPoints) |> ignore
    exitMenuItem.Click.Add(fun _ -> form.Close ())
    menuBezier.Click.Add(fun _ -> form.Invalidate())
    menuCanonical.Click.Add(fun _ -> form.Invalidate())
    menuControlPoints.Click.Add(fun _ -> form.Invalidate())
    menu
```

You're now ready to use the functions you defined to configure the controls. Set up the scrollbar and register the controls in the form and the event handlers for the various events. Finally, start the application's event loop and play with it:

```
scrollbar.ValueChanged.Add(fun _ -> form.Invalidate())
form.Controls.Add(scrollbar)
form.MainMenuStrip <- setupMenu()
form.Controls.Add(form.MainMenuStrip)
form.Paint.Add(fun e -> paint(e.Graphics))
form.MouseDown.Add(fun e -> mouseDown(e.Location))
form.MouseMove.Add(fun e -> mouseMove(e.Location))
form.MouseUp.Add(fun e -> movingPoint <- -1)
form.Show()
```

If you're not using F# Interactive, don't forget to add:

```
[<SThread>]
do Application.Run(form)
```

## Writing Your Own Controls

The Curves example from the previous section draws inside a form by handling events. This is a rare way to draw things in graphical applications, because the resulting code is scarcely reusable, and drawing on the surface of a form raises issues when additional controls have to be placed in its client area.

User controls are the abstraction provided by the Windows Forms framework to program custom controls. If delegation is used to handle events generated from controls, inheritance and method overriding are the tools used to handle them in controls.

## Developing a Custom Control

To make this discussion concrete, consider a control that implements a simple button. You can use the control from C# inside the Visual Studio designer like the native button, as shown in Figure 16-4.

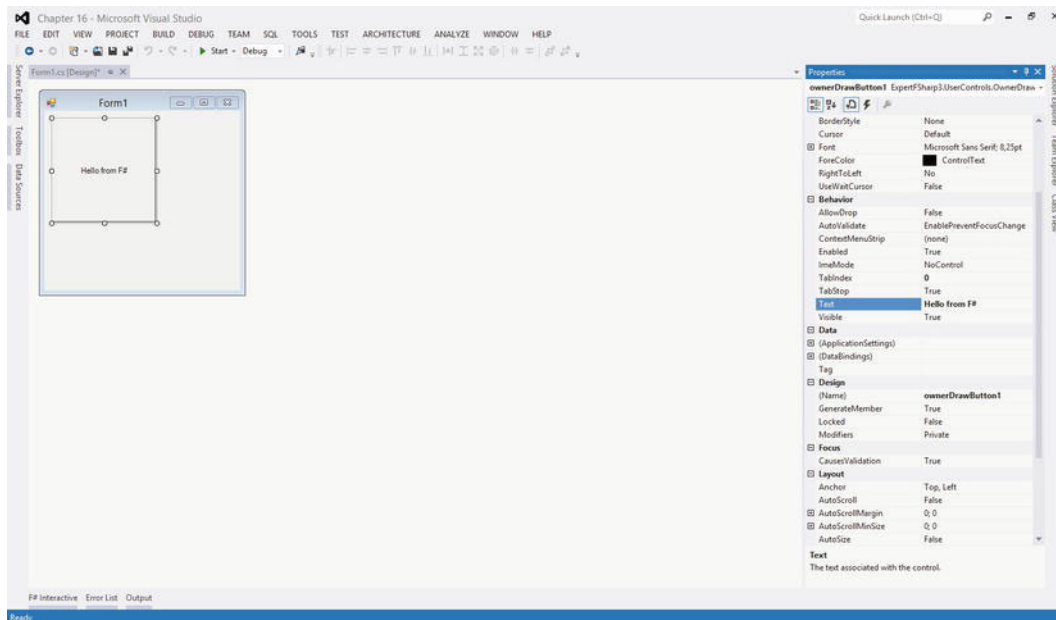

Figure 16-4. The F# button control used in a C# application and the Visual Studio designer

You start your control by inheriting from the `UserControl` class:<sup>2</sup>

```
namespace ExpertFSharp3.UserControls
```

```
open System
open System.Drawing
open System.Windows.Forms
```

<sup>2</sup>Note that this example hasn't been designed to be entered using F# Interactive.

```
open System.ComponentModel

type OwnerDrawButton() =
    inherit UserControl()
```

You then define the state of the control in terms of the class's fields:

```
    let mutable text = ""
    let mutable pressed = false
```

The text field contains the button's label. As with the `movingPoint` variable in the Curves example, the `pressed` field is responsible for remembering whether the button is currently pressed, allowing the paint handler to behave appropriately. You override the `OnPaint` method to handle the paint event. You allocate the pens and the brush required to draw and invert the role of the border colors in order to achieve the raised effect when the button isn't pressed and the depressed look otherwise. You also measure the size of the label string, because you're interested in drawing the string in the center of the button. You can then draw the lines on the borders, playing with colors to obtain a 3D effect. The pens and brushes are disposed of at the end of the function:

```
    override x.OnPaint (e : PaintEventArgs) =
        let g = e.Graphics
        use pll = new Pen(SystemColors.ControlLightLight)
        use pl = new Pen(SystemColors.ControlLight)
        use pd = new Pen(SystemColors.ControlDark)
        use pdd = new Pen(SystemColors.ControlDarkDark)
        use bfg = new SolidBrush(x.ForeColor)
        let szf = g.MeasureString(text, x.Font)
        let spt = PointF((float32(x.Width) - szf.Width) / 2.0f,
                        (float32(x.Height) - szf.Height) / 2.0f)
        let ptt, pt, pb, pbb =
            if pressed then pdd, pd, pl, pll
            else pll, pl, pd, pdd

        g.Clear(SystemColors.Control)
        g.DrawLine(ptt, 0, 0, x.Width - 1, 0)
        g.DrawLine(ptt, 0, 0, 0, x.Height - 1)
        g.DrawLine(pt, 1, 1, x.Width - 2, 1)
        g.DrawLine(pt, 1, 1, 1, x.Height - 2)
        g.DrawLine(pbb, 0, x.Height - 1, x.Width - 1, x.Height - 1)
        g.DrawLine(pbb, x.Width - 1, 0, x.Width - 1, x.Height - 1)
        g.DrawLine(pb, 1, x.Height - 2, x.Width - 2, x.Height - 2)
        g.DrawLine(pb, x.Width - 2, 1, x.Width - 2, x.Height - 2)
        g.DrawString(text, x.Font, bfg, spt)
```

Note the use of the colors defined in the `SystemColors` class: you use the system definition of colors so that the button uses the colors set by the user as display settings. Configuration is an important aspect of a user control, because it's normally performed through a visual editor, such as Visual Studio. Well-defined controls are those that can be highly customized without having to extend the control programmatically or, even worse, to change its source code.

Now that you've defined the drawing procedure, you can define the behavior of the control by handling mouse events. You restrict the implementation to mouse events, although a key event handler should be provided in order to react to a press of the Enter key:

```

override x.OnMouseUp (e : MouseEventArgs) =
    pressed <- false
    x.Invalidate()

override x.OnMouseDown (e : MouseEventArgs) =
    pressed <- true
    x.Invalidate()

```

The `OnMouseDown` event sets the `pressed` member and asks the control to repaint by invalidating its content. When the mouse is released, the `OnMouseUp` is called, and you reset the flag and ask for repaint.

Controls are usually configured through the assignment of properties. If you annotate a property with an attribute of type `Category` and one of type `Browsable`, the property is displayed by Visual Studio in the control property box. To show this, you define the `Text` property, which exposes the button's label to users of the control:

```

[<Category("Behavior")>]
[<Browsable(true)>]
override x.Text
    with get() = text
    and set(t : string) = text <- t; x.Invalidate()

```

You're now ready to test your new control by writing a few lines of F# code as:

```

let form = new Form(Visible = true)
let c = new OwnerDrawButton(Text = "Hello button")

c.Click.Add(fun _ -> MessageBox.Show("Clicked!") |> ignore)
form.Controls.Add(c)

```

To see your control at work in the Visual Studio designer, you must create a Windows Forms application C# project. With the default form created by the application wizard opened, right-click the Toolbox window and select the Choose Items option; then, browse for the `OwnerDrawButton.dll` file obtained by compiling the F# control. Now you can visually drag your F# control into the form and configure its properties using the Properties window.

---

## VSLAB VIEWLETS

---

VSLab is an add-in for Visual Studio, available at <http://vs1ab.codeplex.com>, which allows displaying graphical information inside Visual Studio toolwindows controlled by the F# interactive session. VSLab is built around a notion of *viewlet*, a control capable of showing as a Visual Studio toolwindow, and it can be programmed like a Windows Forms user control. In fact, the base class for `Viewlet` class is `UserControl`; thus, it is possible to program viewlets in the same way as discussed in this chapter with the only limitation being that a viewlet cannot contain other controls. To overcome this limitation, a lightweight controls library has been developed so that standard controls are available to some extent.

---

Custom controls are seen as black-box objects by the applications that host them. Several hacks are possible to handle the behavior of controls from outside (subclassing is often used on Windows), but none of them are really satisfactory. Later, this chapter discusses how this constraint is overcome by the retention-based rendering process feature in WPF.



## Anatomy of a Control

As illustrated by the `OwnerDrawButton` control example, the structure of a graphic control tends to assume the form of a finite state automaton. Events received by the control make the automaton change its internal state, usually causing an update of its actual display.

A well-known model that describes this structure is the Model-View-Controller design pattern. As shown in Figure 16-5, the model organizes a graphical element (either an application or a single control) into three parts: the model, the view, and the controller.

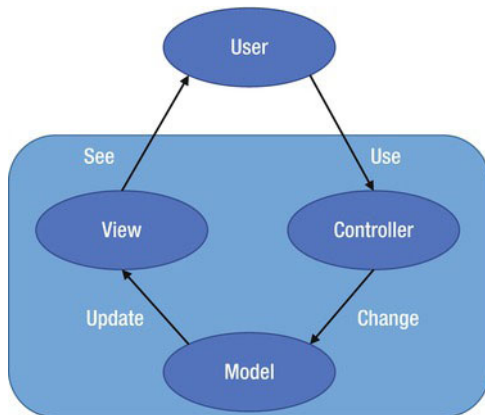

*Figure 16-5. The structure of the Model-View-Controller design pattern*

The model constitutes the internal representation of the information displayed by the control. A word processor, for instance, stores a document in memory as part of the model, even though the entire text doesn't fit the current visible area. In your simple button, the model is defined by the pressed and text values.

When the model changes, the view must be updated, and a rendering of the information kept in memory should be performed. Usually, the `paint` method corresponds to the view portion of the control. Event handlers triggered by the user form the controller of the control. The controller defines how these elements affect the model.

The Model-View-Controller pattern isn't the only model developed to describe graphical interfaces. It captures the intrinsic nature of the problem, however, providing a good framework for classifying the elements of an interface or a control. The rest of this chapter refers to this pattern to indicate the various elements of the applications you learn how to develop.

## Displaying Samples from Sensors

Now that you have reviewed the essential concepts behind programming graphical interfaces, you're ready to work on some applications. They're full of details typical of real graphical applications. This section presents a graphic control whose purpose is to plot samples acquired over time—for instance, from a sensor. The control has been designed to be reusable and highly configurable, providing a rich set of properties that can be set even at runtime by the application hosting it, as shown in Figure 16-6.

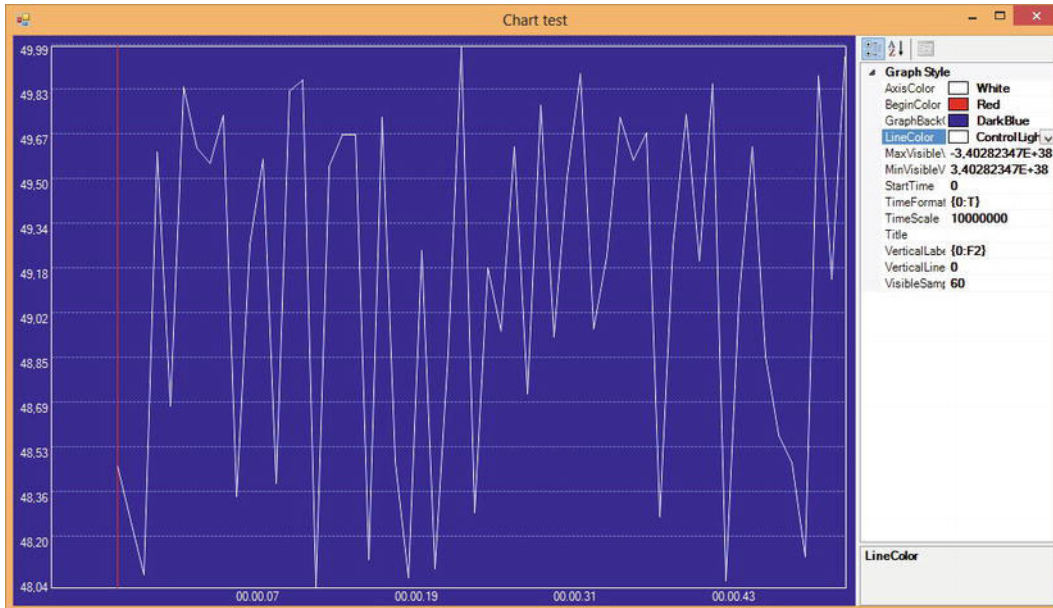

**Figure 16-6.** The `GraphControl` used in a test application that lets the user to change its appearance at runtime

The basic function of the control is to receive and store samples labeled with time. If `c` is the variable that refers to an instance of the control, the application feeds data through an `AddSample` method that adds a new sample to the data set, causing the control to update the displayed chart:

```
c.AddSample(t, v)
```

The next section shows how to define the control and the `AddSample` method.

Despite the simple interface provided by `GraphControl` to update the data set, the control isn't easy to implement, because it must hold a large number of samples and provide a means to navigate through a view that doesn't fit all the samples. Another area important to controls is *configuration*: users of the control want to customize its appearance to fit the needs of their application. To support these needs, you must adopt the coding conventions required to integrate the control in the Windows Forms framework so that it integrates with all the tools used to design applications.

---

## USING FSHARPCHART

---

`GraphControl` implements a micro subset of the `System.Windows.Forms.DataVisualization` library included with the .NET Framework 4.0 and used as the basis for `FSharpChart`. This excerpt shows an output similar to the test program used for the `GraphControl`:

```
let timer = new Timer(Interval = 200)

let rnd = new Random()
let time = ref 0
let data = timer.Tick |> Observable.map(fun _ ->
```

```
incr time
let v = 48.0 + 2.0 * rnd.NextDouble()
(!time, v))
```

```
FSharpChart.Line(data, MaxPoints = 20)
```

The use of `Observable` allows transforming the timer tick into a source of values that cause the update of the line chart. It is not obvious to configure `FSharpChart` to behave exactly as `GraphControl`, because of the many assumptions the control makes about input format and data flow.

---

## Building the `GraphControl`: The Model

According to the Model-View-Controller paradigm, you first define the control's model, which should contain all the information needed to draw the control when required. You first define the type of a sample:

```
type Sample = {Time : int64; Value : float32}
```

Samples are pairs  $(t, v)$ , with  $t$  being the time at which the sample  $v$  has been read. Samples are collected in a data structure named `DataSamples`, whose purpose is to provide a uniform view of data; the class definition is reported in Listing 16-1. Assume that the data set is always small enough to stay in memory; this limitation can be overcome in the future by changing this class. Samples are collected into a `ResizeArray` and kept in the field named `data`. Also, use a form of run-length-encoding (RLE) compression to optimize memory usage, and use linear interpolation to make data appear continuous in order to simplify the implementation of the zoom feature. Because not all the samples are recorded, the count field is used to keep track of the number of added samples.

The `AddSample` method is used to add a new sample to the data set. It assumes that data come sorted with respect to time; if a sample preceding the last added is detected, it's discarded. The `Last` property returns the last-added sample; you may have discarded it because it's equal to the previous, so rebuild the sample using the `lastTime` field that records the time value of the last sample added.

Interpolation is done by the `GetValue` method, which, given a time value, calculates the corresponding value. The list of samples is searched using a binary search. If a sample matches the given time, it's returned; otherwise, the interpolation is performed.

The last operation implemented by `DataSamples` is `FindMinMax`, a method that computes the minimum and maximum values of the data in a given interval. You can initialize the values for minimum and maximum, as well as a stride to use to do the search. The stride is useful in conjunction with zoom, because the number of samples that can be displayed is finite, and the rendering procedure must subsample when zooming out.

### *Listing 16-1. The `DataSamples` class definition*

```
open System
```

```
type Sample = {Time : int64; Value : float32}
```

```
type DataSamples() =
```

```
    let data = new ResizeArray<Sample>()
```

```
    let mutable count = 0
```

```
    let mutable lastTime = 0L
```

```
    member x.Last = {Time = lastTime; Value = data.[data.Count - 1].Value}
```

```

member x.AddSample(t, v) =
  let s = {Time = t; Value = v}
  let last = if (data.Count = 0) then s else x.Last

  count <- count + 1
  lastTime <- max last.Time s.Time
  if data.Count = 0 then data.Add(s)

  elif last.Time < s.Time && last.Value <> s.Value then
    if data.[data.Count - 1].Time <> last.Time then data.Add(last)
    data.Add(s)

member x.Count = count

// The model is continuous: missing samples are obtained by interpolation
member x.GetValue(time : int64) =

  // Find the relevant point via a binary search
  let rec search (lo, hi) =
    let mid = (lo + hi) / 2
    if hi - lo <= 1 then (lo, hi)
    elif data.[mid].Time = time then (mid, mid)
    elif data.[mid].Time < time then search (mid, hi)
    else search (lo, mid)

  if (data.Count = 0) then failwith "No data samples"

  if (lastTime < time) then failwith "Wrong time!"

  let lo, hi = search (0, data.Count - 1)

  if (data.[lo].Time = time || hi = lo) then data.[lo].Value
  elif (data.[hi].Time = time) then data.[hi].Value
  else
    // interpolate
    let p = if data.[hi].Time < time then hi else lo
    let next = data.[min (p+1) (data.Count-1)]
    let curr = data.[p]
    let spant = next.Time - curr.Time
    let spanv = next.Value - curr.Value
    curr.Value + float32(time-curr.Time) *(spanv / float32 spant)

  // This method finds the minimum and the maximum values given
  // a sampling frequency and an interval of time
  member x.FindMinMax(sampleFreq : int64, start : int64, finish : int64,
    minval : float32, maxval : float32) =

    if (data.Count = 0) then (minval, maxval) else
      let start = max start 0L
      let finish = min finish lastTime

```

```

let minv, maxv =
  seq {start .. sampleFreq .. finish}
  |> Seq.map x.GetValue
  |> Seq.fold (fun (minv, maxv) v -> (min v minv, max v maxv))
            (minval, maxval)

if (minv = maxv) then
  let delta = if (minv = 0.0f) then 0.01f else 0.01f * abs minv
  (minv - delta, maxv + delta)
else (minv, maxv)

```

## Building the GraphControl: Style Properties and Controller

Listing 16-2 shows the code for the `GraphControl` class except for the `OnPaint` drawing method, which is shown in the next section. This control exhibits the typical structure of a graphic control; it features a large number of constants and fields that serve configuration purposes. The class inherits from `UserControl`, which is the base class of Windows Forms controls, and it contains a field named `data` of type `DataSamples` that represents the data shown by the control. The appearance is controlled through properties, fields, and constant values; for instance, the axis color is controlled by the pattern:

```

let mutable axisColor:Color = Color.White
[<Category("Graph Style"); Browsable(true)>]
member x.AxisColor
  with get() = x.axisColor
  and set(v:Color) = x.axisColor <- v; x.Invalidate()

```

The `AxisColor` property lets the control's host change the color of the axis color displayed by the control, because properties are part of the controller of the control; thus, when the setter is invoked, you call the `Invalidate` method to ensure that a paint message is sent to the control so that the view is updated. Note that a fully fledged control might read defaults from a store of user-specific configuration properties.

### *Listing 16-2. The GraphControl class*

```

open System
open System.Drawing
open System.Drawing.Drawing2D
open System.Windows.Forms
open System.ComponentModel

type GraphControl() as x =
  inherit UserControl()

  let data = new DataSamples()
  let mutable minVisibleValue = Single.MaxValue
  let mutable maxVisibleValue = Single.MinValue
  let mutable absMax = Single.MinValue
  let mutable absMin = Single.MaxValue
  let mutable lastMin = minVisibleValue
  let mutable lastMax = maxVisibleValue
  let mutable axisColor = Color.White
  let mutable beginColor = Color.Red

```

```

let mutable verticalLabelFormat = "{0:F2}"
let mutable startTime = 0L
let mutable visibleSamples = 10
let mutable initView = startTime - int64(visibleSamples)
let mutable verticalLines = 0
let mutable timeScale = 10000000 // In 100-nanoseconds
let mutable timeFormat = "{0:T}"

let rightBottomMargin = Size(10, 10)
let leftTopMargin = Size(10, 10)

do
    x.SetStyle(ControlStyles.AllPaintingInWmPaint, true)
    x.SetStyle(ControlStyles.OptimizedDoubleBuffer, true)
    base.BackColor <- Color.DarkBlue

[<Category("Graph Style"); Browsable(true)>]
member x.AxisColor
    with get() = axisColor
    and set(v : Color) = axisColor <- v; x.Invalidate()

[<Category("Graph Style"); Browsable(true)>]
member x.BeginColor
    with get() = beginColor
    and set(v : Color) = beginColor <- v; x.Invalidate()

[<Category("Graph Style"); Browsable(true)>]
member x.MinVisibleValue
    with get() = minVisibleValue
    and set(v : float32) =
        minVisibleValue <- v; lastMin <- v; x.Invalidate()

[<Category("Graph Style"); Browsable(true)>]
member x.MaxVisibleValue
    with get() = maxVisibleValue
    and set(v : float32) =
        maxVisibleValue <- v; lastMax <- v; x.Invalidate()

[<Category("Graph Style"); Browsable(true)>]
member x.VerticalLines
    with get() = verticalLines
    and set(v : int) = verticalLines <- v; x.Invalidate()

[<Category("Graph Style"); Browsable(true)>]
member x.GraphBackColor
    with get() = x.BackColor
    and set(v : Color) = x.BackColor <- v

[<Category("Graph Style"); Browsable(true)>]
member x.LineColor
    with get() = x.ForeColor

```

```

    and set(v : Color) = x.ForeColor <- v

[<Category("Graph Style"); Browsable(true)>]
member x.VerticalLabelFormat
    with get() = verticalLabelFormat
    and set(v : string) = verticalLabelFormat <- v; x.Invalidate()

[<Category("Graph Style"); Browsable(true)>]
member x.StartTime
    with get() = startTime
    and set(v : int64) = startTime <- v; x.Invalidate()

[<Category("Graph Style"); Browsable(true)>]
member x.Title
    with get() = x.Text
    and set(v : string) = x.Text <- v; x.Invalidate()

[<Category("Graph Style"); Browsable(true)>]
member x.VisibleSamples
    with get() = visibleSamples
    and set(v : int) =
        visibleSamples <- v;
        initView <- startTime - int64(visibleSamples);
        x.Invalidate()

[<Category("Graph Style"); Browsable(true)>]
member x.TimeScale
    with get() = timeScale
    and set(v : int) = timeScale <- v; x.Invalidate()

[<Category("Graph Style"); Browsable(true)>]
member x.TimeFormat
    with get() = timeFormat
    and set(v : string) = timeFormat <- v; x.Invalidate()

// ... Further portions of this class shown further below

```

Listing 16-3 includes the remaining portions of the `GraphControl` class corresponding to the controller part of the Model-View-Controller paradigm. Samples are added through the `AddSample` method (`AddSampleData` generates random samples to display inside the control). This method adds the sample to the inner `DataSamples` object and updates the values of two fields meant to store the minimum and maximum values recorded for samples; both of these values are used in the display process. Because the model of the control changes, you need to update the view, and you invalidate the control as you did for properties.

---

## OVERRIDING VS. DELEGATION

---

Event handling can be performed by both subscribing delegates and overriding methods. The former approach is more typical of applications; the latter is more common in control development. Method

overriding guarantees more control over event handling, because it allows a complete redefinition of the inherited behavior, whereas with delegation, you can only add behavior.

When an overridden method starts with a call to the method to be overridden in the base class, it's functionally equivalent to using delegation rather than method overriding. It's traditional, however, to use method overriding in the case of control development, in order to have a uniform notation for event handling.

Be careful during method overriding, because if the call to the overridden method is omitted, the corresponding delegate event isn't fired: delegate events are invoked by the event handlers of the base classes.

---

Let's look at how to handle the mouse-move events and the use of the mouse wheel. When the wheel of the mouse is scrolled, the control adjusts the scale factor to zoom in or out of the current view. To understand how this method works, you need to know how to decide which portion of the data is made available through the view of the control. You use two fields: `initView` and `visibleSamples`. Because you can't assume that all the samples fit in the control's display, the former indicates the time (in the time scale of the samples) corresponding to the leftmost visible value, and the latter indicates the number of time units in the unit scale of samples that should be visible. Zooming is performed by changing the density of time units to be displayed inside the viewport.

The last method in Listing 16-3 is `GetTime`: it converts the time unit of samples in microseconds using a scale factor that is one of the configuration properties made available by the control.

*Listing 16-3. Extract of the controller of the `GraphControl` class*

```

override x.OnMouseWheel (e : MouseEventArgs) =
    base.OnMouseWheel(e)
    x.Zoom(e.Delta)

override x.OnSizeChanged (e : EventArgs) =
    base.OnSizeChanged(e)
    x.Invalidate()

member x.Zoom (amount : int) =
    let newVisibleSamples = max 5 (visibleSamples + amount)
    if (initView - startTime < 0L) then
        let e = initView + int64(visibleSamples)
        initView <- startTime - int64(newVisibleSamples) + e
        visibleSamples <- newVisibleSamples
        x.Invalidate()

member x.AddSample (time : int64, value : float32) =
    if (value < absMin) then absMin <- value
    if (value > absMax) then absMax <- value
    if (data.Count > 0) then
        initView <- initView + time - data.Last.Time
    data.AddSample(time, value)
    x.Invalidate()

member x.GetTime (time : int64) =
    DateTime(max 0L time * int64(timeScale))

```



## Building the GraphControl: The View

The view of the `GraphControl` is entirely contained within the `OnPaint` method, which is invoked when the GUI needs to repaint the content of the control or when an invocation of the `Invalidated` method occurs. Listing 16-4 shows the full code for this method. Programming graphical controls can get complicated, and often the code is factorized further using functions.

The `OnPaint` method begins computing some information, such as the rectangles containing the string with the values to be displayed. The dimension of a string depends on the font used for display and the particular device context used to render it. You rely on the `MeasureString` method of the `Graphics` object you received from the GUI. You compute the `plotBox` rectangle, which represents the area where you draw the data; it's obtained by removing from the dimension of the control that the margins specified in the configuration and the space required by the labels, if visible. Later, set an appropriate coordinate system on the device context so that the drawing primitives render in this new system:

```
g.TranslateTransform(float32(plotBox.Left), float32(x.Height - plotBox.Top))
g.ScaleTransform(1.0f, -1.0f)
```

You translate the origin of the coordinate system in the lower-left vertex of the margins rectangle. You also flip the  $y$  axis by setting a scale transform that inverts the direction, multiplying  $y$  coordinates by  $-1.0f$ ; in this way, you obtain a coordinate system oriented as in mathematics. Coordinate transformation is supported by Windows Forms on the `Graphics` object: all the coordinates specified in the drawing primitives are affected by a transformation matrix stored in the device context. Once set, a transformation of the library takes care of the calculations necessary to rotate, translate, and scale all the objects.

After clearing the background using the `Background` color property, you draw the various lines, such as the axes and the labels, depending on the configuration settings specified by setting the control's properties. This is the typical structure of a paint method, in which the model is tested to decide what should be drawn and the style to be used.

The drawing of the data samples is controlled by the `timePerUnit` and `pixelsPerUnit` variables, and then the inner recursive function `drawSamples` selects the visible samples and uses the `DataSamples` object to compute results. You rely on the ability of the `DataSamples` class to interpolate data and to not have to deal with discrete samples.

The core business of the paint method is often simple (having paid attention when you defined the model and the controller of the control); it quickly becomes entangled in testing all the configuration properties to determine how the control should be rendered.

### *Listing 16-4. Drawing the control*

```
override x.OnPaint (e : PaintEventArgs) =
    let g = e.Graphics

    // A helper function to size up strings
    let msrstr s = g.MeasureString(s, x.Font)

    // Work out the size of the box to show the values
    let valBox =
        let minbox = msrstr (String.Format(verticalLabelFormat, lastMin))
        let maxbox = msrstr (String.Format(verticalLabelFormat, lastMax))
        let vbw = max minbox.Width maxbox.Width
        let vbh = max minbox.Height maxbox.Height
        SizeF(vbw, vbh)

    // Work out the size of the box to show the times
```

```

let timeBox =
    let lasttime = x.GetTime(initView + int64(visibleSamples))
    let timelbl = String.Format(timeFormat, lasttime)
    msrstr timelbl

// Work out the plot area for the graph
let plotBox =
    let ltm = leftTopMargin
    let rbm = rightBottomMargin

    let ltm, rbm =
        let ltm = Size(width = max ltm.Width (int(valBox.Width) + 5),
                       height = max ltm.Height (int(valBox.Height / 2.0f) + 2))
        let rbm = Size(width = rightBottomMargin.Width,
                       height = max rbm.Height (int(timeBox.Height) + 5))
        ltm, rbm

    // Since we invert y axis use Top instead of Bottom and vice versa
    Rectangle(ltm.Width, rbm.Height,
              x.Width - ltm.Width - rbm.Width,
              x.Height - ltm.Height - rbm.Height)
// The time interval per visible sample
let timePerUnit =
    let samplew = float32(visibleSamples) / float32(plotBox.Width)
    max 1.0f samplew

// The pixel interval per visible sample
let pixelsPerUnit =
    let pixelspan = float32(plotBox.Width) / float32(visibleSamples)
    max 1.0f pixelspan

// Compute the range we need to plot
let (lo, hi) = data.FindMinMax(int64(timePerUnit),
                               initView,
                               initView + int64(visibleSamples),
                               minVisibleValue,
                               maxVisibleValue)

// Save the range to help with computing sizes next time around
lastMin <- lo; lastMax <- hi

// We use these graphical resources during plotting
use linePen = new Pen(x.ForeColor)
use axisPen = new Pen(axisColor)
use beginPen = new Pen(beginColor)
use gridPen = new Pen(Color.FromArgb(127, axisColor),
                      DashStyle = DashStyle.Dash)
use fontColor = new SolidBrush(axisColor)

// Draw the title
if (x.Text <> null && x.Text <> String.Empty) then

```

```

let sz = msrstr x.Text
let mw = (float32(plotBox.Width) - sz.Width) / 2.0f
let tm = float32(plotBox.Bottom - plotBox.Height)

let p = PointF(float32(plotBox.Left) + mw, tm)
g.DrawString(x.Text, x.Font, new SolidBrush(x.ForeColor), p)

// Draw the labels
let nly = int((float32(plotBox.Height) / valBox.Height) / 3.0f)
let nlx = int((float32(plotBox.Width) / timeBox.Width) / 3.0f)
let pxly = plotBox.Height / max nly 1
let pxlx = plotBox.Width / max nlx 1
let dvy = (hi - lo) / float32(nly)
let dvx = float32(visibleSamples) / float32(nlx)
let drawString (s : string) (xp : float32) (yp : float32) =
    g.DrawString(s, x.Font, fontColor, xp, yp)

// Draw the value (y) labels
for i = 0 to nly do
    let liney = i * pxly + int(valBox.Height / 2.0f) + 2
    let lblfmt = verticalLabelFormat
    let posy = float32(x.Height - plotBox.Top - i * pxly)
    let label = String.Format(lblfmt, float32(i) * dvy + lo)
    drawString label (float32(plotBox.Left) - valBox.Width)
                    (posy - valBox.Height / 2.0f)

    if (i = 0 || ((i > 0) && (i < nly))) then
        g.DrawLine(gridPen, plotBox.Left, liney, plotBox.Right, liney)

// Draw the time (x) labels
for i = 0 to nlx do
    let linex = i * pxlx + int(timeBox.Width / 2.0f) + 2
    let time = int64(float32(i) * dvx + float32(initView))
    let label = String.Format(timeFormat, x.GetTime(time))

    if (time > 0L) then
        drawString label
            (float32(plotBox.Left + i * pxlx) + timeBox.Width / 2.0f)
            (float32(x.Height - plotBox.Top + 2))

// Set a transform on the graphics state to make drawing in the
// plotBox simpler
g.TranslateTransform(float32(plotBox.Left),
                    float32(x.Height - plotBox.Top));
g.ScaleTransform(1.0f, -1.0f);

// Draw the plotBox of the plot area
g.DrawLine(axisPen, 0, 0, 0, plotBox.Height)
g.DrawLine(axisPen, 0, 0, plotBox.Width, 0)
g.DrawLine(axisPen, plotBox.Width, 0, plotBox.Width, plotBox.Height)
g.DrawLine(axisPen, 0, plotBox.Height, plotBox.Width, plotBox.Height)

```

```

// Draw the vertical lines in the plotBox
let px = plotBox.Width / (verticalLines + 1)
for i = 1 to verticalLines do
    g.DrawLine(gridPen, i * px, 0, i * px, plotBox.Height)

// Draw the 'begin' marker that shows where data begins
if (initView - startTime <= 0L) then
    let off = float32(Math.Abs(x.StartTime - initView))
    let sx = int((off / timePerUnit) * pixelsPerUnit)
    g.DrawLine(beginPen, sx, 0, sx, plotBox.Height)

// Draw the 'zero' horizontal line if it's visible
if (hi <> lo && lo < 0.0f) then
    let sy = int((float32(plotBox.Height) / (hi - lo)) * (0.0f - lo))
    g.DrawLine(axisPen, 0, sy, plotBox.Width, sy)

// Draw the visible data samples
let rec drawSamples i pos =
    if (i < (float32(plotBox.Width) / pixelsPerUnit) &&
        pos <= (initView + int64 visibleSamples - int64 timePerUnit))
    then
        if (pos >= 0L) then
            let dh = float32(plotBox.Height) / (hi - lo)
            let sx = int(pixelsPerUnit * i)
            let dx = int(pixelsPerUnit * (i + 1.0f))
            let sy = int(dh * (data.GetValue(pos) - lo))
            let dy = int(dh * (data.GetValue(pos + int64 timePerUnit)
                - lo))
            g.DrawLine(linePen, sx, sy, dx, dy);

            drawSamples (i + 1.0f) (pos + int64 timePerUnit)

drawSamples 0.0f initView

```

---

## DOUBLE BUFFERING

---

Flickering is a very annoying phenomenon of graphical applications. It happens when two updates of a graphical element are interleaved by a refresh of its background. The graphic adapter sends the video signal to the display, reading bytes from video memory at a given frequency that is different than the update frequency of the paint message.

Flickering happens during animations when a pixel is cleared with the background color and then with the desired one. The graphic adapter may display the pixel before the update, making it blink. A standard technique for avoiding this phenomenon is known as *double buffering*: it consists of performing the drawing primitives into a bitmap offscreen; then, when the entire drawing is finished, the bitmap is drawn.

You can easily implement double buffering explicitly, although modern frameworks provide support for it. The example uses the `SetStyle` method inherited from `UserControl` to enable implicit support for double buffering. If you comment out the two invocations to that method, you see flickering in action.

---

## Putting It Together

The following code uses the control that defines the application shown in Figure 16-6:

```
let form = new Form(Text = "Chart test", Size = Size(800, 600), Visible = true, TopMost = true)
let graph = new GraphControl(VisibleSamples = 60, Dock = DockStyle.Fill)
let properties = new PropertyGrid(Dock = DockStyle.Fill)
let timer = new Timer(Interval = 200)
let container = new SplitContainer(Dock = DockStyle.Fill, SplitterDistance = 350)

// We use a split container to divide the area into two parts
container.Panel1.Controls.Add(graph)
container.Panel2.Controls.Add(properties)

// Configure the property grid to display only properties in the
// category "Graph Style"
properties.SelectedObject <- graph
let graphStyleCat = (CategoryAttribute("Graph Style") :> Attribute)
properties.BrowsableAttributes <- AttributeCollection([|graphStyleCat|])
form.Controls.Add(container)
let rnd = new Random()
let time = ref 0
// A timer is used to simulate incoming data
timer.Tick.Add(fun _ ->
    incr time
    let v = 48.0 + 2.0 * rnd.NextDouble()
    graph.AddSample(int64(!time), float32(v)))
timer.Start()
form.Disposed.Add(fun _ -> timer.Stop())
```

The form uses a `SplitContainer` control to define two areas, one for `GraphControl` and the other for a `PropertyGrid` control. A timer object is used to add samples periodically, and you use the `AddSample` method to add random samples to the control.

---

## THE PROPERTYGRID CONTROL

---

`PropertyGrid` is a graphic control that lets you inspect object properties at runtime and change them, as shown in the right side of the window in Figure 16-6. You set the `SelectedObject` property to indicate the control to display, in this case the `GraphControl`.

`PropertyGrid` uses the reflection abilities of the Common Language Runtime to dynamically inspect the object and generate the visual grid. By default, the control displays the properties of the given object annotated using the `BrowsableAttribute` custom attribute. You set the `BrowsableAttributes` property to indicate that you're interested in displaying only the properties annotated as `[<Category("Graph Style")>]`.

Not all types can be edited from the `PropertyGrid`, although the control can deal with many. A property of type `Color`, for instance, causes the grid to display the preview of the color and lets you define the value several ways, including the `Color Chooser` dialog box.

---

## Creating a Mandelbrot Viewer

Fractals are one of the diamonds of mathematics. They show the beauty of mathematical structures visually, which allows nonexperts to see something that is often hidden by formulas that few really appreciate. The Mandelbrot set is one of the most famous fractals. This section shows how to develop an application to browse this set. The result is shown in Figure 16-7.

This application adopts the *delegation* programming style, subscribing to events rather than using inheritance to override the behavior of a component. This allows you to develop the application interactively using `fsi.exe`. This is a good example of how effectively you can use F# to develop an application interactively while retaining the performance of a compiled language, which is extremely important in such CPU-intensive tasks as computing the points of the Mandelbrot set.

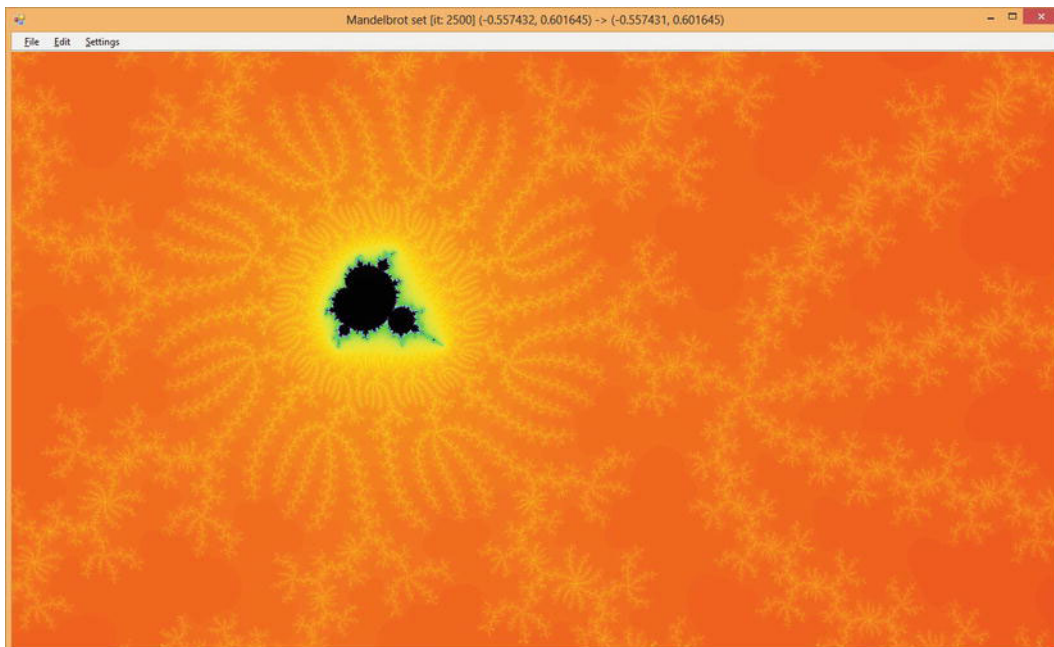

Figure 16-7. The Mandelbrot viewer in action

## Computing Mandelbrot

First, you need to be familiar with the math required to generate the Mandelbrot set. The set is defined over the set of complex numbers, which is an extension of the real numbers, allowing computation of square roots over negative numbers. A complex number has the following form, where  $a$  and  $b$  are real numbers and  $i$  is the imaginary unit (by definition,  $i^2 = -1$ ):

$$c = a + bi$$

Using standard algebraic calculations, you can define the sum and product of these numbers:

$$c1 + c2 = (a1 + a2) + (b1 + b2) i$$

$$c1 \cdot c2 = (a1 \cdot a2 - b1 \cdot b2) + (a1 \cdot b2 + a2 \cdot b1) i$$

Because you have two components in the definition of the number, you can graphically represent complex numbers using a plane.

This Mandelbrot viewer shows a portion of the complex plane in which each point in the plane is colored according to a relation that defines the Mandelbrot set. The relation is based on the iterative definition:

$$M(c) = \begin{cases} z_0 = c \\ z_{i+1} = z_i^2 + c \end{cases}$$

A complex number belongs to the Mandelbrot set if  $z_n$  converges for  $n$ . You can test each number  $c$  in the complex plane and decide whether the number belongs to the Mandelbrot set. Because it's not practical to perform an infinite computation to test each number of the complex plane, there is an approximation of the test based on a theorem that if the distance of  $z_i$  from the origin passes 2, then the sequence will diverge, and the corresponding  $z_0$  won't belong to the set.

The code to compute membership of the Mandelbrot set is:

```
open System.Numerics

let sqrMod (x : Complex) = x.Real * x.Real + x.Imaginary * x.Imaginary
let rec mandel maxit (z : Complex) (c : Complex) count =
    if (sqrMod(z) < 4.0) && (count < maxit) then
        mandel maxit ((z * z) + c) c (count + 1)
    else count
```

You can create a simple visual representation of the Mandelbrot set by coloring all the points belonging to the set. In this way, you obtain the black portion of Figure 16-7. How can you obtain the richness of color? The trick is to color points depending on how fast the sequence reaches the distance of 2 from the origin. You use 250 colors and map the  $[0, \text{maxit}]$  interval to the  $[0, 250]$  discrete color interval.

## Setting Colors

In order for the Mandelbrot viewer application to have appealing coloring, you need to produce some form of continuity in the color variation in the chosen range. Use an array of colors to store these values, but you need a procedure to fill this array so that colors change continuously.

Colors in the Red Green Blue (RGB) space used in graphics libraries are known to define a color space that isn't perceived as continuous by human vision. A color space known to be more effective in this respect is the Hue Saturation Value (HSV), in which a color is defined in terms of hue, color saturation, and the value of luminance (see Figure 16-8). This model was inspired by the method used by painters to create colors in oil painting.

Figure 16-8 shows a typical geometric representation of the two color spaces. In the RGB color model, the three axes represent the three base colors varying from black to the full color; in the HSV space, the angle is used to indicate the hue, the distance from the axis of the cone represents the saturation, and the value corresponds to the height of the point inside the cone.

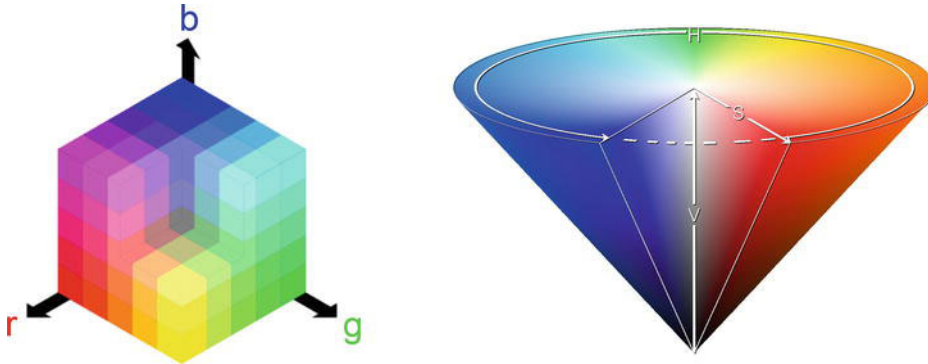

**Figure 16-8.** The RGB (left) and HSV (right) color spaces and their geometric representation

You can define a conversion from RGB color space to HSV, and vice versa. Listing 16-5 shows the F# functions performing the conversions between the two models. These functions assume the three components R, G, and B are in the interval  $[0, 1]$  rather than integers between 0 and 255.

**Listing 16-5.** Conversion from RGB to HSV, and vice versa

```
let RGBtoHSV (r, g, b) =
    let (m : float) = min r (min g b)
    let (M : float) = max r (max g b)
    let delta = M - m
    let posh (h : float) = if h < 0.0 then h + 360.0 else h
    let deltaf (f : float) (s : float) = (f - s) / delta
    if M = 0.0 then (-1.0, 0.0, M) else
        let s = (M - m) / M
        if r = M then (posh(60.0 * (deltaf g b)), s, M)
        elif g = M then (posh(60.0 * (2.0 + (deltaf b r))), s, M)
        else (posh(60.0 * (4.0 + (deltaf r g))), s, M)

let HSVtoRGB (h, s, v) =
    if s = 0.0 then (v, v, v) else
        let hs = h / 60.0
        let i = floor (hs)
        let f = hs - i
        let p = v * (1.0 - s)
        let q = v * (1.0 - s * f)
        let t = v * (1.0 - s * (1.0 - f))
        match int i with
        | 0 -> (v, t, p)
        | 1 -> (q, v, p)
        | 2 -> (p, v, t)
        | 3 -> (p, q, v)
        | 4 -> (t, p, v)
        | _ -> (v, p, q)
```

To let users choose the coloring of the set, you create an array of 10 functions, given an integer between 0 and 250, for a corresponding color. The default color function is based on the HSV color model;



it uses the input parameter to set the hue of the color, leaving the saturation and luminance at the maximum values. The other functions use the RGB color space, following directions in the color cube. You use the `createPalette` function to generate the color palette that is used while drawing fractal points; the `palette` mutable variable holds this palette. Listing 16-6 shows the code that deals with colors. The `pickColor` function is responsible for mapping the iteration `it`, at which the computation of the Mandelbrot set terminates given the maximum number of iterations allowed, `maxit`.

**Listing 16-6. Color-palette definition**

```
let makeColor (r, g, b) =
    let f x = int32(x * 255.0)
    Color.FromArgb(f(r), f(g), f(b))

let defaultColor i = makeColor(HSVtoRGB(360.0 * (float i / 250.0), 1.0, 1.0))

let coloring =
    [
        defaultColor;
        (fun i -> Color.FromArgb(i, i, i));
        (fun i -> Color.FromArgb(i, 0, 0));
        (fun i -> Color.FromArgb(0, i, 0));
        (fun i -> Color.FromArgb(0, 0, i));
        (fun i -> Color.FromArgb(i, i, 0));
        (fun i -> Color.FromArgb(i, 250 - i, 0));
        (fun i -> Color.FromArgb(250 - i, i, i));
        (fun i -> if i % 2 = 0 then Color.White else Color.Black);
        (fun i -> Color.FromArgb(250 - i, 250 - i, 250 - i))
    ]

let createPalette c =
    Array.init 253 (function
        | 250 -> Color.Black
        | 251 -> Color.White
        | 252 -> Color.LightGray
        | i -> c i)

let mutable palette = createPalette coloring.[0]

let pickColor maxit it =
    palette.[int(250.0 * float it / float maxit)]
```

## Creating the Visualization Application

You're now ready to implement the graphical application. The basic idea is to map a rectangle of the complex plane in the client area of your form. Each point of your window corresponds to a complex number and is colored according to the value computed by the `mandel` function.

A typical value for `maxit` is 150 for the initial rendering of the Mandelbrot set, although it should be incremented when zooming into the fractal. The total computation required to generate an entire image is significant; therefore, you can't rely on the main thread to perform the computation of the various points. It's

important to recall that event handlers are invoked by the graphical interface's thread, and if this thread is used to perform heavy computations, the application windows won't respond to other events.

You introduce a thread responsible for performing the computations required by the Mandelbrot set so that the GUI thread can continue to handle events. (Chapter 11 discusses threads in more detail.) Here, you use shared memory to communicate the results between the threads by using a bitmap image in memory, referenced by the `bitmap` variable, which is updated by the thread performing the computation task and read by the GUI thread when the form must be painted. The bitmap is convenient, because you need a matrix of points to be colored, and the device context is designed to avoid pixel coloring to be device independent (it doesn't provide a `SetColor(x, y)` operation). To avoid race conditions, use the `lock` function to guarantee exclusive access to the bitmap shared between the two threads. Chapter 11 looks at this in more detail. The thread responsible for the set computation executes the function:

```
// t=top, l=left, r=right, b=bottom, bm=bitmap, p=pixel, w=width, h=height
let run filler (form : #Form) (bitmap : Bitmap) (tlx, tly) (brx, bry) =
    let dx = (brx - tlx) / float bmpw
    let dy = (tly - bry) / float bmpw
    let maxit = iterations (tlx, tly) (brx, bry)
    let x = 0
    let y = 0
    let transform x y = new Complex(tlx + (float x)* dx, tly - (float y) * dy)
    form.Invoke(new MethodInvoker(fun () ->
        form.Text <- sprintf "Mandelbrot set [it: %d] (%f, %f) -> (%f, %f)"
            maxit tlx tly brx bry
    )) |> ignore
    filler maxit transform
    timer.Enabled <- false
```

Use `dx` and `dy` variables to map the `x` and `y` coordinates of the bitmap into the complex plane. Then invoke the `filler` function responsible for performing the calculation. There are different possible filling strategies to compute the colors of the set; the straightforward approach is left to right and top to bottom, implemented by the `linearFill` function:

```
let linearFill (bw : int) (bh : int) maxit map =
    for y = 0 to bh - 1 do
        for x = 0 to bw - 1 do
            let c = mandel maxit Complex.Zero (map x y) 0
            lock bitmap (fun () -> bitmap.SetPixel(x, y, pickColor maxit c))
```

Another typical filling strategy is to gradually refine the set by computing points in blocks and filling the blocks of the appropriate color; then, the missing points are computed by refining the block size. Using this strategy, you can provide a quick preview of the fractal without having to wait for the entire computation. The `blockFill` function implements this strategy:

```
let blockFill (bw : int) (bh : int) maxit map =
    let rec fillBlock first sz x y =
        if x < bw then
            let c = mandel maxit Complex.Zero (map x y) 0
            lock bitmap (fun () ->
                let g = Graphics.FromImage(bitmap)
                g.FillRectangle(new SolidBrush(pickColor maxit c),
                    x, y, sz, sz)
                g.Dispose())
            fillBlock first sz
```

```

                (if first || ((y / sz) % 2 = 1) then x + sz
                 else x + 2 * sz) y
    elif y < bh then
        fillBlock first sz
            (if first || ((y / sz) % 2 = 0) then 0 else sz) (y + sz)
    elif sz > 1 then
        fillBlock false (sz / 2) (sz / 2) 0

```

```
fillBlock true 64 0 0
```

The variable `fillFun` is used to store the current filling function:

```
let mutable fillFun = blockFill
```

You clear the bitmap by obtaining a device context to the bitmap and clearing it. The global variable `bitmap` is used to access the image from the code; this is an effective choice to speed up the development of the application. This technique can be a problem from a software engineering standpoint, however, because the program is less modular, and the mutable state isn't encapsulated:

```
let clearOffScreen (b : Bitmap) =
    use g = Graphics.FromImage(b)
    g.Clear(Color.White)
```

```
let mutable bitmap = new Bitmap(form.Width, form.Height)
let mutable bmpw = form.Width
let mutable bmpH = form.Height
```

To refresh the application form while the fractal computation is ongoing, use a timer that triggers a refresh of the form every tenth of a second (the fully qualified name for the `Timer` class is needed to disambiguate between `System.Threading.Timer` and `System.Windows.Forms.Timer`). The `paint` function draws the bitmap that is updated by the worker thread:

```
let paint (g : Graphics) =
    lock bitmap (fun () -> g.DrawImage(bitmap, 0, 0))
    g.DrawRectangle(Pens.Black, rect)
    g.FillRectangle(new SolidBrush(Color.FromArgb(128, Color.White)), rect)
```

```
let timer = new System.Windows.Forms.Timer(Interval = 100)
timer.Tick.Add(fun _ -> form.Invalidate() )
```

```
let stopWorker () =
    if worker <> Thread.CurrentThread then
        worker.Abort()
        worker <- Thread.CurrentThread
```

The `drawMandel` function is responsible for starting the rendering process:

```
let drawMandel () =
    let bf = fillFun bmpw bmpH
    stopWorker()
    timer.Enabled <- true
    worker <- new Thread(fun () -> run bf form bitmap tl br)
    worker.IsBackground <- true
    worker.Priority <- ThreadPriority.Lowest
    worker.Start()
```

## Creating the Application Plumbing

Now that you've defined the architecture of the application, you can define the graphical aspects, the form, and the menus, as well as how users interact with the application. The code is similar to the previous applications, as shown in Listing 16-7. Note two aspects: the `rect` variable contains the current selection, and it's drawn as a rectangle filled with transparent white; the application uses the clipboard to store and retrieve the coordinates of a particular fractal view or save the current state of the drawn bitmap. When `Ctrl+C` is pressed, a small XML document similar to the following is saved to the clipboard:

```
<Mandel iter="1000">
  <topleft>
    <re>-7.47421339220139e-001</re>
    <im>1.64667039391667e-001</im>
  </topleft>
  <bottomright>
    <re>-7.47082959511805e-001</re>
    <im>1.64413254610417e-001</im>
  </bottomright>
</Mandel>
```

The saved parameters are the most compact representation of the current view, and they are loaded back if `Ctrl+V` is pressed; this way, you can save the state of navigation. You save and read text from the clipboard using the `Clipboard` class's `SetText` and `GetText` methods. When the `Ctrl+Shift+C` key sequence is pressed, the current bitmap is copied to the clipboard using the `SetDataObject` method; the bitmap can be pasted in any program capable of pasting images.

The selection rectangle is updated by the mouse event handlers. You obtain the zoom facility by setting the bounds of the complex plane defined by the variables `tl` and `br`.

### *Listing 16-7. Setup of the application form and event handling*

```
type CanvasForm() as x =
  inherit Form()
  do x.SetStyle(ControlStyles.OptimizedDoubleBuffer, true)
  override x.OnPaintBackground(args) = ()

// Creates the Form
let form = new CanvasForm(Width = 800, Height = 600, Text = "Mandelbrot set")
let timer = new Timer(Interval = 100)
timer.Tick.Add(fun _ -> form.Invalidate() )

let mutable worker = Thread.CurrentThread
let mutable bitmap = new Bitmap(form.Width, form.Height)
let mutable bmpw = form.Width
let mutable bmpH = form.Height
let mutable rect = Rectangle.Empty
let mutable tl = (-3.0, 2.0)
let mutable br = (2.0, -2.0)

let mutable menuIterations = 150

let iterations (tlx, tly) (brx, bry) =
  menuIterations
```

```

let RGBtoHSV (r, g, b) = ...
let HSVtoRGB (h, s, v) = ...
let makeColor (r, g, b) = ...
let defaultColor i = ...
let coloring = ...
let createPalette c = ...
let mutable palette = createPalette coloring.[0]
let pickColor maxit it = ...
let sqrMod (x : Complex) = ...
let run filler (form : #Form) (bitmap : Bitmap) (tlx, tly) (brx, bry) = ...
let linearFill (bw : int) (bh : int) maxit map = ...
let blockFill (bw : int) (bh : int) maxit map = ...
let mutable fillFun = blockFill
let clearOffScreen (b : Bitmap) = ...
let paint (g : Graphics) = ...
let stopWorker () = ...
let drawMandel () = ...

let mutable startsel = Point.Empty

let setCoord (tlx : float, tly : float) (brx : float, bry : float) =
    let dx = (brx - tlx) / float bmpw
    let dy = (tly - bry) / float bmph
    let mapx x = tlx + float x * dx
    let mapy y = tly - float y * dy
    tl <- (mapx rect.Left, mapy rect.Top)
    br <- (mapx rect.Right, mapy rect.Bottom)

let ensureAspectRatio (tlx : float, tly : float) (brx : float, bry : float) =
    let ratio = (float bmpw / float bmph)
    let w, h = abs(brx - tlx), abs(tly - bry)
    if ratio * h > w then
        br <- (tlx + h * ratio, bry)
    else
        br <- (brx, tly - w / ratio)

let updateView () =
    if rect <> Rectangle.Empty then setCoord tl br
    ensureAspectRatio tl br
    rect <- Rectangle.Empty
    stopWorker()
    clearOffScreen bitmap
    drawMandel()

let click (arg : MouseEventArgs) =
    if rect.Contains(arg.Location) then
        updateView()
    else
        form.Invalidate()
        rect <- Rectangle.Empty
        startsel <- arg.Location

```

```

let mouseMove (arg : MouseEventArgs) =
    if arg.Button = MouseButton.Left then
        let tlx = min startsel.X arg.X
        let tly = min startsel.Y arg.Y
        let brx = max startsel.X arg.X
        let bry = max startsel.Y arg.Y
        rect <- new Rectangle(tlx, tly, brx - tlx, bry - tly)
        form.Invalidate()

let resize () =
    if bmpw <> form.ClientSize.Width ||
        bmpw <> form.ClientSize.Height then
        stopWorker()
        rect <- form.ClientRectangle
        bitmap <- new Bitmap(form.ClientSize.Width, form.ClientSize.Height)
        bmpw <- form.ClientSize.Width
        bmpw <- form.ClientSize.Height

        updateView()

let zoom amount (tlx, tly) (brx, bry) =
    let w, h = abs(brx - tlx), abs(tly - bry)
    let nw, nh = amount * w, amount * h
    tl <- (tlx + (w - nw) / 2., tly - (h - nh) / 2.)
    br <- (brx - (w - nw) / 2., bry + (h - nh) / 2.)
    rect <- Rectangle.Empty
    updateView()

let selectDropDownItem (l : ToolStripMenuItem) (o : ToolStripMenuItem) =
    for el in l.DropDownItems do
        let item = (el :>) ToolStripMenuItem
        item.Checked <- (o = item)

let setFillMode (p : ToolStripMenuItem) (m : ToolStripMenuItem) filler _ =
    if (not m.Checked) then
        selectDropDownItem p m
        fillFun <- filler
        drawMandel()

let setupMenu () =
    let m = new MenuStrip()
    let f = new ToolStripMenuItem("&File")
    let c = new ToolStripMenuItem("&Settings")
    let e = new ToolStripMenuItem("&Edit")
    let ext = new ToolStripMenuItem("E&xit")
    let cols = new ToolStripComboBox("ColorScheme")
    let its = new ToolStripComboBox("Iterations")
    let copybmp = new ToolStripMenuItem("Copy &bitmap")
    let copy = new ToolStripMenuItem("&Copy")
    let paste = new ToolStripMenuItem("&Paste")
    let zoomin = new ToolStripMenuItem("Zoom &In")

```

```

let zoomout = new ToolStripMenuItem("Zoom &Out")
let fillMode = new ToolStripMenuItem("Fill mode")
let fillModeLinear = new ToolStripMenuItem("Line")
let fillModeBlock = new ToolStripMenuItem("Block")

let itchg = fun _ ->
    menuIterations <- System.Int32.Parse(its.Text)
    stopWorker()
    drawMandel()
    c.HideDropDown()
ext.Click.Add(fun _ -> form.Dispose()) |> ignore

copybmp.Click.Add(fun _ -> Clipboard.SetDataObject(bitmap))|> ignore
copybmp.ShortcutKeyDisplayString <- "Ctrl+Shift+C"
copybmp.ShortcutKeys <- Keys.Control ||| Keys.Shift ||| Keys.C

copy.Click.Add(fun _ ->
    let maxit = (iterations tl br)
    let tlx, tly = tl
    let brx, bry = br
    Clipboard.SetText(sprintf "<Mandel iter=\"%d\"><topleft><re>%14e</re><im>%14e</im></
topleft><bottomright><re>%14e</re><im>%14e</im></bottomright></Mandel>" maxit tlx tly brx bry)
) |> ignore
copy.ShortcutKeyDisplayString <- "Ctrl+C"
copy.ShortcutKeys <- Keys.Control ||| Keys.C

paste.Click.Add(fun _ ->
    if Clipboard.ContainsText() then
        let doc = new XmlDocument()
        try
            doc.LoadXml(Clipboard.GetText())
            menuIterations <-
                int (doc.SelectSingleNode("/Mandel").Attributes["iter"].Value)
            tl <- (float (doc.SelectSingleNode("//topleft/re").InnerText),
                float (doc.SelectSingleNode("//topleft/im").InnerText))
            br <- (float (doc.SelectSingleNode("//bottomright/re").InnerText),
                float (doc.SelectSingleNode("//bottomright/im").InnerText))
            rect <- Rectangle.Empty
            updateView()
        with _ -> ()
    ) |> ignore
paste.ShortcutKeyDisplayString <- "Ctrl+V"
paste.ShortcutKeys <- Keys.Control ||| Keys.V

zoomin.Click.Add(fun _ -> zoom 0.9 tl br) |> ignore
zoomin.ShortcutKeyDisplayString <- "Ctrl+T"
zoomin.ShortcutKeys <- Keys.Control ||| Keys.T
zoomout.Click.Add(fun _ -> zoom 1.25 tl br) |> ignore
zoomout.ShortcutKeyDisplayString <- "Ctrl+W"
zoomout.ShortcutKeys <- Keys.Control ||| Keys.W

```

```

for x in [f; e; c] do m.Items.Add(x) |> ignore
f.DropDownItems.Add(ext) |> ignore
let tsi x = (x :> ToolStripItem)
for x in [tsi cols; tsi its; tsi fillMode] do c.DropDownItems.Add(x)
|> ignore
for x in [tsi copy; tsi paste; tsi copybmp; tsi zoomin; tsi zoomout] do
e.DropDownItems.Add(x) |> ignore
for x in ["HSL Color"; "Gray"; "Red"; "Green"] do cols.Items.Add(x)
|> ignore
fillMode.DropDownItems.Add(fillModeLinear) |> ignore
fillMode.DropDownItems.Add(fillModeBlock) |> ignore
cols.SelectedIndex <- 0
cols.DropDownStyle <- ComboBoxStyle.DropDownList

cols.SelectedIndexChanged.Add(fun _ ->
palette <- createPalette coloring.[cols.SelectedIndex]
stopWorker()
drawMandel()
c.HideDropDown()
)
its.Text <- string menuIterations
its.DropDownStyle <- ComboBoxStyle.DropDown
for x in ["150"; "250"; "500"; "1000"] do its.Items.Add(x) |> ignore
its.LostFocus.Add(itchg)
its.SelectedIndexChanged.Add(itchg)
fillModeBlock.Checked <- true
fillModeLinear.Click.Add(setFillMode fillMode fillModeLinear linearFill)
fillModeBlock.Click.Add(setFillMode fillMode fillModeBlock blockFill)
m

clearOffScreen bitmap
form.MainMenuStrip <- setupMenu()
form.Controls.Add(form.MainMenuStrip)
form.MainMenuStrip.RenderMode <- ToolStripRenderMode.System
form.Paint.Add(fun arg -> paint arg.Graphics)
form.MouseDown.Add(click)
form.MouseMove.Add(mouseMove)
form.ResizeEnd.Add(fun _ -> resize())
form.Show()

Application.DoEvents()

drawMandel()

[<SThread>]
do Application.Run(form)

```

Use the program's last statement only if the application is compiled; with `fsi.exe`, it must be omitted. As already noted, the plumbing code is dominated by setting up menus and configuring the application form; the rest contains the event handlers that are registered with the various controls.



# Windows Presentation Foundation

Microsoft introduced a new presentation framework called Windows Presentation Foundation (WPF) for programming graphical applications on the Windows platform with Windows Vista. It's not merely a new framework, such as Windows Forms; rather than another layer on top of the traditional Win32 presentation system, it's a complete new rendering system that coexists with the traditional one. More recently, Windows 8 introduced a new UI framework, the foundation and architecture of which has its roots in WPF and requires a compiler to output a new binary format called winmd.

---

**Note:** WPF is a .NET framework and thus accessible to F# applications. In Visual Studio, the tight integration with XAML markup language used by WPF isn't supported by the F# project system, and you should instead add your XAML files to your Visual Studio solution. You can also use F# to develop Silverlight code, because Silverlight is a Web plug-in featuring a subset of WPF capabilities. It is possible, however, to use the XAML type provider available in the `FSharpX.TypeProviders` package, obtainable with NuGet, to access XAML defined objects within F# source code. With this clever type provider, it is possible to use any XAML visual designer, including Blend and Visual Studio, and bind to XAML elements F# code in a way similar to what happens to WPF applications developed using C#. Also, note that the F# compiler is not able to generate winmd format yet, though F# assemblies can be used from C# Windows 8 UI projects.

---

At first sight, a WPF application doesn't differ much from a Windows Forms application. Here are few lines of code to open a window from F# Interactive:

```
#r "WindowsBase"
#r "PresentationCore"
#r "PresentationFramework"
#r "System.Xaml"

open System.Windows
open System.Windows.Controls

let w = new Window()

let b = new Button(Content = "Hello from WPF!")
b.Click.Add(fun _ -> w.Close())

w.Content <- b
w.Show()
```

The application has an event loop (see the sidebar “WPF Event Loop”) hosted by F# Interactive. With a few (very important) differences, you've created a window hosting a huge button that closes it when clicked.

---

## WPF EVENT LOOP

---

WPF applications have an event loop, because events are still one of the foundations of this new presentation system; this event loop, however, differs from that used by Windows Forms applications. It's started through

an instance of the `System.Windows.Application` class (note that in Windows Forms, the `System.Windows.Forms.Application` class is used as a singleton without the need to create instances).

To run the button example as a stand-alone application, add the same references to the F# project. Instead of the `w.Show()` method invocation, you can add the following lines:

```
let a = new Application()
```

```
[<SThread>]
do a.Run(w) |> ignore
```

F# Interactive can host both Windows Forms and WPF event loops, so you can create windows using both frameworks, even at the same time. F# Interactive, however, uses Windows Forms by default. There is a script called `load_wpf.fsx` in the F# Power Pack that you must load into an F# interactive session and start with a Windows Forms event loop, in order to enable full WPF support. You must also explicitly refer to WPF assemblies before creating WPF objects.

---

It's reassuring that events are still there, even within a framework based on a different programming paradigm. Moreover, you still create user interfaces by composing graphical controls and attaching to their event handlers. The button is the only control hosted by the window! You don't access a `Controls` property of the window to add the button to a list of children controls. Instead, you set all the window content with a button, resulting in a huge button that occupies the window's entire client area.

WPF's layout model is completely different from what you've grown accustomed to using Windows Forms: objects are positioned by the container and don't have `Top` and `Left` properties to explicitly set a control position.

Layout is only one of many aspects of WPF that diverge from the traditional structure of graphic toolkits; this section introduces the most relevant. Look for more information about the framework in dedicated publications. The most important changes introduced by WPF are:

- Retention-based, device-independent rendering
- XML-based composition language
- Dependency properties and animations

## When GUIs Meet the Web

The long-established model of GUI toolkits has its roots in a world very different from today's. Several assumptions made by these programming models are still true, but others no longer hold. This is an important point that you must always consider when working with WPF after any other graphical toolkit.

One of the authors was introduced to graphical programming during the 1980s, using Turbo Pascal, and was surprised that drawing primitives weren't retained by the system like console characters. The situation, however, was better than it had been a few years before, on a MS-DOS PC with graphics: the screen buffer was owned by a single application, so redrawing was needed to remove a primitive and restore its background. With windowing systems, the user experience improved significantly for the user, but the situation worsened for the application programmer: the application's main control must be delegated to the graphical toolkit, and everything becomes an event. Events significantly optimize resource usage, because applications are notified only when needed so that a user can execute multiple applications simultaneously, but events are also used to optimize drawing resources through the paint architecture discussed previously. As you've seen, the GUI system sends the paint message to a window whenever its content needs to be updated; therefore, primitives aren't retained by the windowing system. It's up to you to issue them as necessary.

In essence, the familiar paint-event-based paradigm you're used to exists because of the need to save memory when it's scarce; this is a form of Kolmogorov-style compression, in which a program generates information instead of storing it. As illustrated by Web browsers, today's computers have enough memory to change this underlying assumption and revise the original decision of who is responsible for retaining graphics primitives. With WPF, Microsoft decided to radically change the toolkit model and define a foundation based on the notion of graphics-primitive retention.

This example shows how a typical drawing is performed by a WPF application:

```
#r "WindowsBase"
#r "PresentationCore"
#r "PresentationFramework"

open System.Windows
open System.Windows.Controls
open System.Windows.Shapes
open System.Windows.Media

let c = new Canvas()
let w = new Window(Topmost = true, Content = c)
w.Show()

let r = new Rectangle(Width = 100., Height = 100.,
    RadiusX = 5., RadiusY = 5.,
    Stroke = Brushes.Black)
c.Children.Add(r)

let e = new Ellipse(Width = 150., Height = 150.,
    Stroke = Brushes.Black)
c.Children.Add(e)
Canvas.SetLeft(e, 100.)
Canvas.SetTop(e, 100.)

e.MouseLeftButtonUp.Add(fun _ ->
    e.Fill <-
        if e.Fill = (Brushes.Yellow :> Brush) then Brushes.Red
        else Brushes.Yellow)
```

At first, this example doesn't differ much from the one showing a button in a window: you create a Canvas object, which is a container for multiple UI elements, and add two graphic objects. In the Windows Form world, you'd think of two graphic controls used for drawing, although they wouldn't blend, because each traditional window is opaque. In fact, these two graphics primitives are represented by two objects and are retained by the presentation system; pick correlation and event dispatching are guaranteed by the graphical toolkit.

Note that the ellipse is an outline, so the click event is raised only by clicking the outline; when the fill brush is specified, you can change the fill color by clicking inside the ellipse. Another relevant aspect is the positioning of an element: there is no Left or Top property, because it's the responsibility of the container (in this case, the canvas) to lay out contained objects.

## Drawing

An application can draw any shape by adding graphics primitives to a WPF window's *visual tree*. Because the system retains these primitives, you don't need to implement an event handler for the paint message: it's up to the graphical toolkit to render the tree in the appropriate way whenever needed. Problems such as visible primitives and efficient drawing fade away quickly and are dealt with by the system; nevertheless, you're still responsible for using the visual tree.

Because graphics primitives are organized in a tree structure, it's natural to use an XML-based language to initialize this tree with the window's initial state. WPF introduced the XAML language for this purpose; it recalls HTML, though it was designed for defining rich UIs instead of hypertext. The drawing example shown in the previous section can be expressed using the XAML markup in Listing 16-8.

**Listing 16-8.** Example of a window definition using XAML.

```
<Window xmlns="http://schemas.microsoft.com/winfx/2006/xaml/presentation"
        xmlns:x="http://schemas.microsoft.com/winfx/2006/xaml"
        Title="MainWindow" Height="350" Width="525">
  <Canvas>
    <Rectangle Width="100" Height="100" Stroke="Black"
              RadiusX="5" RadiusY="10"/>
    <Ellipse Name="Circle"
            Canvas.Left="100" Canvas.Top="100"
            Width="150" Height="150" Stroke="Black"/>
  </Canvas>
</Window>
```

The markup syntax is a wonderful tool for compacting several programming-language statements into a single line, because properties can be set as attributes. XAML adopts a well-defined bridge between the XML elements and the corresponding .NET classes and objects. Tag names are mapped onto classes and implicitly define instances, attributes are used to assign objects' properties, and attributes containing a dot are interpreted as static properties (for example, `Canvas.Left` and `Canvas.Top`). Each node may have a *name*, which is useful for retrieving a reference to the node; in this case, the ellipse element is named `Circle`.

---

## LOADING XAML INTO F# APPLICATIONS

---

At the time of writing, the F# project system in Visual Studio 2010 doesn't include full XAML support. This means there is no WPF Visual Studio Wizard for the F# language. For C#, the compilation process for WPF applications involves a precompilation of XAML files in C# source files and an optimized representation of XAML called Binary XAML (BAML). The source-code generation has the goal of making it easier to interact with graphical objects defined within the XAML file using a mechanism successfully employed for ASP.NET files: *code behind*. Using the special attribute `x:Class`, you can indicate a class in which to inject the definition of graphical elements of the XAML file, so that C# methods can be referred to through XML attributes (to indicate event handlers) and XAML objects are exposed as fields. It's possible, however, to load XAML at runtime, letting F# applications benefit from the ability to use XAML UI definitions instead of having to manipulate WPF objects explicitly. The following is a simple example of a function that loads XAML markup from a file and, assuming it contains the definition of a window, converts the reference into an instance of the `Window` class:

```
#r "WindowsBase"
#r "PresentationCore"
#r "PresentationFramework"
```

```
#r "System.Xaml"

open System.Windows
open System.Windows.Controls
open System.Windows.Markup
open System.Windows.Media
open System.Xml

let loadXamlWindow (filename : string) =
    let reader = XmlReader.Create(filename)
    XmlReader.Load(reader) :?> Window

System.Environment.CurrentDirectory <- __SOURCE_DIRECTORY__
let wnd = loadXamlWindow("window.xaml")
wnd.Show()
```

You can use a WYSIWYG editor for XAML to visually author UIs. To load it in an F# application, ensure that the `x:Class` attribute is removed; otherwise, the `Load` method will raise an exception. Don't associate event handlers through the UI: they should be explicitly associated inside the F# code.

Using these functions, you can load any XAML fragment. In F#, the most common case is to load the definition of a window. It's also possible to parse XAML code embedded in strings: for instance, in the resources embedded in the application or embedded as a string within the program. The rest of this chapter refers to this function without including its definition.

Using the `FSharpX` type provider for XAML you can also load the `Window.xaml` code as:

```
// The full Nuget package path is not shown and will vary with your installation
#r @"...\packages\...\FsharpX.Core.dll"
#r @"...\packages\...\FsharpX.TypeProviders.dll"

open FSharpX

type MainWindow = XAML<"window.xaml">

let mainwnd = new MainWindow()
let wnd = mainwnd.Root
wnd.Show()
```

The type provider here is generating, at compile time, a set of types representing part of the visual tree defined in the XAML file. The main difference is that many type checks are anticipated at compile time, avoiding runtime type-cast exceptions. This use of type providers avoids source-code generation typical of C# WPF code-generation integration and offering a set of features similar to those available for C#.

XAML has been rightly touted as separating the world of business logic from that of UI design, offering direct control to graphic designers through XAML and allowing programmers to rely on names to instrument graphical controls. XAML and the names of graphical elements are the contract between programmers and designers, allowing for concurrent work on GUI-application development. This approach has proven successful for the Web and shows that hardware is powerful enough to shift toward a more programmer-friendly paradigm.

XAML can be generated and manipulated from a number of graphical editors, including Visual Studio and Microsoft Expression Blend. Even though full support isn't yet available for developing WPF applications using F#, it's easy to load XAML-based UIs into F# applications; this largely addresses the

lack of graphical environments for developing GUIs (see the sidebar “Loading XAML into F# Applications”). Assuming that the XAML in Listing 16-8 is saved in a file named `window.xaml`, you can use it from F# (assuming the appropriate references and the `loadXamlWindow` function are defined) as:

```
let w = loadXamlWindow("window.xaml")
w.Show()

let e = w.FindName("Circle") :?> Ellipse

e.MouseLeftButtonUp.Add(fun _ ->
    e.Fill <-
        if e.Fill = (Brushes.Yellow :> Brush) then Brushes.Red
        else Brushes.Yellow)
```

You use the `FindName` method to find a reference to the ellipse object; this is how you can refer from F# code to elements defined in the XAML markup, unless you use the XAML type provider, in which case you simply access the `Circle` property on the type generated by the provider. Because you can define animations in markup and connect to user actions (for example, sliding or collapsing menus can be defined entirely in XAML), the number of statements needed to connect the F# state to the visual tree is small—drastically smaller than the amount of code needed to do GUIs in Windows Forms. Sometimes it may be useful to navigate the entire visual tree in which WPF stores the graphics primitives; the `VisualTreeHelper` class features navigation methods useful for doing this.

Drawing primitives refer to the coordinates of some coordinate space. Traditionally, computer programs relied on pixels, even though Win32 API supported different coordinate systems from the beginning. WPF features vector graphics, supporting affine transformations of the coordinate system (translation, rotation, scaling, and skew); the use of a pixel-based system seemed obsolete in a world in which the dots per inch (dpi) of display devices changes significantly. The adopted unit is 1/96<sup>th</sup> of an inch (in honor of the traditional monitor resolution), whatever the target display device, including printers.

You can apply transformations to any subtree of the visual tree, transforming all the primitives, including those issued by contained controls.

Let’s consider the XAML example shown in Listing 16-9. It uses a container that stacks graphical elements horizontally to lay out three elements: a block of text, a text box, and a line. Nodes may also have explicit names, such as the `TextBox` node here. The application’s output is shown in Figure 16-9, where the elements are rotated according to the indicated transformations: the container is laid out rotated 45 degrees counterclockwise, and the text box is rotated 90 degrees clockwise.

**Listing 16-9.** XAML defining the composition of transformed elements

```
<Window xmlns="http://schemas.microsoft.com/winfx/2006/xaml/presentation"
        xmlns:x="http://schemas.microsoft.com/winfx/2006/xaml"
        Title="MainWindow" Height="350" Width="525">
  <Canvas>
    <StackPanel Orientation="Horizontal" VerticalAlignment="Center">
      <StackPanel.LayoutTransform>
        <RotateTransform Angle="-45"/>
      </StackPanel.LayoutTransform>
      <TextBlock>This is a test</TextBlock>
      <TextBox Name="Input">
        <TextBox.LayoutTransform>
          <RotateTransform Angle="90"/>
        </TextBox.LayoutTransform>
        Input here
      </TextBox>
    </StackPanel>
  </Canvas>
</Window>
```

```

        </TextBox>
        <Line X1="0" X2="50" Y1="0" Y2="50" Stroke="Black"/>
    </StackPanel>
</Canvas>
</Window>

```



Figure 16-9. F# application demonstrating the XAML

Transformations are implemented using matrices, as already discussed for Windows Forms; you can use them to obtain nontrivial transformations of the coordinate space. These transformations affect the subtree rooted in the node to which they're applied and can be programmatically accessed through the `LayoutTransform` and `RenderTransform` properties. The former affects the layout computation, and the latter affects the final rendering, possibly overflowing the container node.

Drawing involves brushes and pens, which are similar to their Windows Forms counterparts.

## Controls

The ability to instantiate and use existing controls is one of the pillars of user interfaces. In the earlier discussion of the difference between writing components and combining them, it was evident that a control in a traditional framework is *opaque*: the container allocates a rectangle and delegates event handling and drawing to the window procedure coordinated by the event loop.

In WPF, things are less clear-cut, which opens new horizons to graphical developers who appreciate the visual tree and the different role played by controls. To appreciate the extent of this statement, let's modify the example from Listing 16-9 by enclosing the `StackPanel` element in a `Button` element (add a `<Button>` tag immediately after `<Canvas>` and `</Button>` immediately before `</Canvas>`). The resulting window looks like the one shown in Figure 16-10: you've nested two controls, which is an almost impossible task in traditional graphical toolkits.

The designers of the WPF framework must have considered problems that never came up with traditional toolkits, given the system's ability to retain graphics primitives in the form of a tree. You can think of a button as a background shaped like a button, with the label in the middle; it can be defined as a subtree of the primitives needed to draw its borders and a placeholder in the middle to insert the label. In an opaque system, the content could be another rectangle but nothing more; in a retention-based system, you can replace the label node in the tree with an arbitrary, complicated subtree.

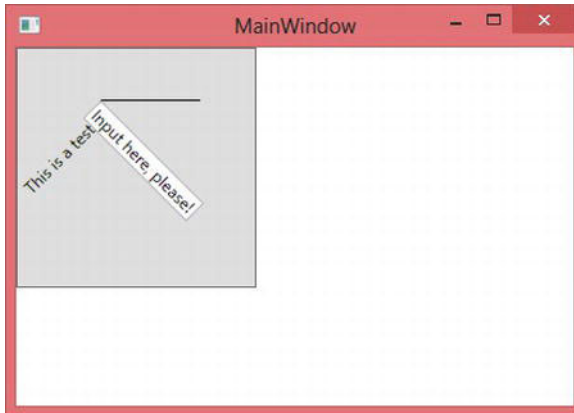

Figure 16-10. Nested controls in WPF

You can display the visual tree of any WPF element using the static methods of the `VisualTreeHelper` class. The following F# function prints to the console (or in the F# Interactive tool window) the visual tree associated with a WPF element:

```
let ShowVisualTree(obj : DependencyObject) =
    let rec browse indentlvl node =
        let indent n = for i = 0 to (n - 1) do printf "  "
        let n = VisualTreeHelper.GetChildrenCount(node)

        indent indentlvl
        printfn "<%=s%>" (node.GetType().Name) (if n = 0 then "/" else "")
        for i = 0 to (n - 1) do
            browse (indentlvl + 1) (VisualTreeHelper.GetChild(node, i))
        if n > 0 then
            indent indentlvl
            printfn "</%=s%>" (node.GetType().Name)

    browse 0 obj
```

---

■ **Note:** WPF also defines the *logical tree*, which is a simplified version of the visual tree that hides formatting nodes. The logical tree makes it easier to find relevant controls without having to deal with unneeded nodes. Logical tree is not available on lighter versions of WPF, such as Silverlight.

---

The function implements a recursive visit to the visual tree rooted in the given element. If you pass the instance returned by `loadXamlWindow`, you get an idea of how many primitives are issued by the various controls you're using in the window. If you pass the instance of a button, perhaps found using the `FindName` method as you did earlier, you obtain output similar to:

```
<Button>
  <ButtonChrome>
    <ContentPresenter>
      <TextBlock/>
```



```

    </ContentPresenter>
  </ButtonChrome>
</Button>

```

ContentPresenter is the root of the subtree dedicated to the button content; the rest defines the graphics primitives surrounding the node. The ButtonChrome node refers to a class used to implement a specific theme; it's even possible to change the definition of the button without affecting its logic or its content. You can find more information about this ability of WPF in textbooks or online.

---

## EVENTS AND WPF

---

What are the consequences of a model in which controls are no longer black boxes? The most important is the notion of pick correlation: in the example, if you click the text block or line, you get the container button that has been pressed, but if the click is directed to the text box, the button doesn't receive it. Event routing in WPF is more complicated than in other toolkits, because events are tunneled to tree nodes from the root toward the control and then bubbled up backward. In this way, the button may know that it's clicked in the first phase but may ignore the click event in the second phase. In addition, transparency may cause the same event to be triggered to more than one control at the same time. All these possibilities require further study of WPF that is beyond the scope of this book.

The type expected by the ShowVisualTree function is DependencyObject, which returns to the notion of *dependency*—a pervasive concept deeply entrenched within the framework. Dependency is a relation among two or more elements; in its asymmetry, it expresses something whose nature depends on something else. Dependency properties are a programming pattern used across WPF to define properties that you can listen to for change. If *w* is a Window object obtained from parsing the XAML contained in Listing 16-9, you can read and set the Text property of the TextBox object from F#:

```

let t = w.FindName("Input") :?> TextBox
MessageBox.Show(sprintf "Input value is %s " t.Text) |> ignore
t.Text <- "Hello"
MessageBox.Show(sprintf "Input value now is %s " t.Text) |> ignore

```

The Text property behaves as a standard property, and you can use it programmatically as you're used to doing with all properties. Text is a dependency property, and any observer in the code can listen for changes. You can detect its change as:

```
open System.ComponentModel
```

```

let desc =
  DependencyPropertyDescriptor.FromProperty(TextBox.TextProperty, typeof<TextBox>)
desc.AddValueChanged(t, fun _ _ -> MessageBox.Show("Text changed!") |> ignore)

```

You use the conventions used by TextBox implementers to access the descriptor of the Text dependency property called TextProperty and rely on appropriate data structures to register your callback. Whenever the text-box value changes, a message box is displayed.

Implementing a dependency property is easy: in the class, you define a static field describing the property; then, the property must be registered in a global structure hosted by the DependencyProperty class. You then add a standard .NET property using the GetValue and SetValue methods—inherited from the DependencyObject class, which must be an ancestor of the class defining the property—hiding the implementation details. Supported callbacks are registered to inform the framework about the observable events on the property (such as the property-value change).

At first, this may seem unnecessarily verbose: why is it useful to be able to observe when a property changes its value? The answer lies in WPF's ability to support the animation of virtually any element property and the fact that dependency properties are the building blocks of the animation engine. Animations often correlate properties of different visual objects. For instance, think of an object and its shadow: whenever the object's position changes, its shadow must follow. Dependency properties provide a pervasive infrastructure to propagate property changes across visual tree nodes in a consistent way. To exemplify this idea, let's change Listing 16-9 again by replacing the `TextBox` element definition with:

```
<TextBlock Text="{Binding Path=Text, ElementName=Input}"></TextBlock>
```

The expression in curly braces is a *data-binding* expression, which is an expression evaluated by WPF engine to set the `Text` property of the `TextBlock` node. If you run the example, the text block updates its content when the text box changes its value. WPF defines several forms of data binding to declare how dependency properties must be updated without explicit coding; you can define several automatic actions using these mechanisms.

In WPF, controls are a way to instantiate subtrees and attach predefined behaviors to nodes and properties. They're less opaque in WPF than before; nevertheless, if a change in the visual tree disrupts the assumptions made by a control's logic, a control may fail. For this reason, controls in WPF offer placeholders for inserting content, as you've seen with buttons, as well as a means to change the control's appearance while preserving the essential traits of the visual subtree that make its inner code work.

## Bitmaps and Images

Vector graphics, after being abandoned in favor of raster graphics, have again become popular, because they let you define graphics that can be scaled without the annoying pixelated effects typical of raster graphics. Vector primitives are exact, and the rendering engine can compute the value of any number of pixels affected by the primitive. If you zoom a line, you can compute all the pixels of the line without any loss in detail. If the line is contained in a bitmap, this isn't possible: the zoomed line contains artifacts introduced by the algorithm that resized the image.

It's impossible to imagine a user interface without images. What, however, does it mean to work with pixels in a world of abstract coordinates where points are considered sizeless entities, as in geometry? An image's size is defined in the application space, and WPF is responsible for the rastering process and for generating enough pixels at a given resolution. A 100×100 image at 96dpi uses the same number of pixels on a standard monitor, or more pixels if the device has a higher dpi resolution. This concept isn't unfamiliar: in the Mandelbrot example, you used a bitmap to set pixel colors, because of the lack of a `SetPixel` method on the `Graphics` object representing the device context for drawing. WPF, however, defines its own set of classes to deal with images, featuring a slightly different set of properties and capabilities.

To exemplify the use of images with WPF, let's consider a simple but useful application: a batch-size conversion for JPEG images. The application is a command-line tool that converts a directory containing hi-res pictures into a mirrored version containing resized versions of the same pictures for a specific resolution. With this tool, it's easy to convert thousands of photos into versions suitable for a photo frame, thus saving space. The conversion process preserves JPEG metadata information such as tags, which may be useful after conversion.

The two main functions are shown in Listing 16-10. `transformFile` is responsible for transforming a single JPEG image and saving it into a new file; `transformDir` performs a recursive visit to a directory tree and builds a mirror tree in the destination directory, relying on the first function to convert the image files.

The image transformation relies on `JpegBitmapDecoder` and `JpegBitmapEncoder`, two classes dealing with the JPEG format. These classes support a streaming model for decoding and encoding images, so you read information about the first frame (an image may contain more than a single frame) to ensure that all the metadata is read from the source image. The desired output size is passed in the form of a screen

resolution through the width and height arguments, and a best-fit policy is used to define the size of an in-memory bitmap instance of the class `BitmapImage`. The image resize is performed by asking the in-memory image to load data from the source file and fit the desired size; this way, you avoid allocating the full image in memory and performing the resize operation while reading pixels from disk. You then use the encoder to save the image, with the desired quality, in the new file, along with the metadata and the creation-time and change-time information.

**Listing 16-10.** *A function to resize all the images in a directory*

```
open System
open System.IO
open System.Windows.Media.Imaging

let transformFile quality width height srcFileName outFileName =
    let dec = new JpegBitmapDecoder(
        Uri(srcFileName),
        BitmapCreateOptions.PreservePixelFormat,
        BitmapCacheOption.Default)
    let w = dec.Frames.[0].Width
    let h = dec.Frames.[0].Height

    let b = new BitmapImage()
    b.BeginInit()
    b.UriSource <- new Uri(srcFileName)
    if width > 0 then
        if w >= h then b.DecodePixelWidth <- width
        else b.DecodePixelHeight <- height
    b.EndInit()

    let metadata = dec.Frames.[0].Metadata

    let enc = new JpegBitmapEncoder()
    enc.Frames.Add(BitmapFrame.Create(b, null,
        metadata :> BitmapMetadata, null))
    let fs = new FileStream(outFileName, FileMode.OpenOrCreate)
    enc.QualityLevel <- quality
    enc.Save(fs)
    fs.Close()
    let fin = new FileInfo(srcFileName)
    let fout = new FileInfo(outFileName)
    fout.CreationTime <- fin.CreationTime
    fout.LastWriteTime <- fin.LastWriteTime

let transformDir quality width height src dest =
    let rec visit (dirIn : DirectoryInfo) (dirOut : DirectoryInfo) =
        for f in dirIn.EnumerateFiles() do
            if f.Extension.ToUpper() = ".JPG" then
                printfn "Processing file %s..." f.FullName
                transformFile
                    quality width height f.FullName
                    (dirOut.FullName + "\\\" + f.Name)
```

```

    for d in dirIn.EnumerateDirectories() do
        visit d (dirOut.CreateSubdirectory(d.Name))

let dirIn = new DirectoryInfo(src)
let dirOut =
    if not(Directory.Exists(dest)) then Directory.CreateDirectory dest
    else new DirectoryInfo(dest)
visit dirIn dirOut

```

Start the transformation process by invoking the `transformDir` function with the JPEG compression quality, the target screen size, and the input and output folders. The following lines assume that you're converting summer photos for a frame supporting 1024×768 resolution:

```

let dn = @"C:\Users\SomeUser\Pictures\Summer 2010"
let dno = @"e:\Summer PhotoFrame 2010"

```

```
transformDir 75 1027 768 dn dno
```

Bitmap manipulation can be very tricky using WPF, and some tasks are more difficult than they are using Windows Forms. In particular, it's easy to obtain a device context to a bitmap and draw using GDI functions. You can raster WPF primitives into a bitmap, but many programmers prefer to refer to both libraries and to convert images from one framework to the other, in an attempt to benefit from both worlds.

## Final Considerations

WPF isn't just another framework built on top of the traditional Win32 and GDI rastering engine: it's a new presentation system designed with a different programming paradigm in mind. This section introduced some important ideas behind this new presentation system and how you can use it from F# applications. The content is far from exhaustive, and several topics have been left out or only mentioned in an attempt to convey the core ideas as a starting point for further investigation. The literature about WPF is very rich, and we encourage you to read more specific material.

## Summary

Event-driven programming is the dominant paradigm of graphical applications. Although object-oriented programming is used to build the infrastructure for graphical frameworks, events are naturally expressed in terms of calling back a given function. F# is effective in GUI programming, because it supports both paradigms and provides access to full-featured frameworks, such as Windows Forms.

This chapter covered the basics of GUI programming. It introduced controls and applications, including details typical of real-world applications. The presentation was based on the Windows Forms framework, but many of the ideas discussed can be easily transposed to other graphical frameworks: the fundamental structure of this class of applications is mostly unchanged. Finally, we introduced WPF and discussed differences between it and Windows Forms.

## CHAPTER 17



# Language-Oriented Programming: Advanced Techniques

Chapters 3 to 6 covered three well-known programming paradigms in F#: *functional*, *imperative*, and *object* programming. Throughout this book, however, you have in many ways been exploring what is essentially a fourth programming paradigm: *language-oriented programming*. In this chapter, you will focus on advanced aspects of language-oriented programming through language-integrated, domain-specific languages and meta-programming.

The word *language* can have a number of meanings in this context. For example, take the simple language of arithmetic expressions and algebra that you learned in high school mathematics, made up of named variables, such as  $x$  and  $y$ , and composite expressions, such as  $x+y$ ,  $xy$ ,  $-x$ , and  $x^2$ . For the purposes of this chapter, this language can have a number of manifestations:

- One or more *concrete representations*: for example, using an ASCII text format or an XML representation of arithmetic expressions.
- One or more *abstract representations*: for example, as F# types and values representing the normalized form of an arithmetic expression tree.
- One or more *computational representations*, either by functions that compute the values of arithmetic expressions or via other engines that perform analysis, interpretation, compilation, execution, or transformation on language fragments. These can be implemented in F#, in another .NET language, or in external engines.

The language-oriented programming techniques covered in this book (including some in this chapter) are:

- Manipulating unstructured text and binary representations of languages, including writing parsers and lexers (Chapter 8)
- Manipulating semi-structured language representations, such as XML (Chapter 8)
- Using F# functions, types, and active patterns for abstract and symbolic representations of languages (Chapters 3, 9 and 12)
- Using F# sequence expressions, asynchronous expressions, and, more generally, F# computation expressions for tightly language-integrated representations of some languages (Chapters 9, 11, and 13, and this chapter)

- Using the F# “dynamic” operators to give a slightly improved syntax for accessing information stored using dynamic (untyped) representation techniques (this chapter)
- Using F# reflection and quotations to represent languages via meta-programming (this chapter)

As you can see, language-oriented programming isn’t a single technique; sometimes you work with fully concrete representations (for example, reading bits from disk) and sometimes with fully computational representations (for example, defining and using functions that compute the value of arithmetic expressions). Most often, you work somewhere in between (for example, manipulating abstract syntax trees). These tasks require different techniques, and there are trade-offs among choosing to work with different kinds of representations. For example, if you’re generating human-readable formulae, then you may need to store more concrete information; but if you’re interested just in evaluating arithmetic expressions, then a purely computational encoding may be more effective. You see some of those trade-offs in the different techniques described above.

---

■ **Note:** The term *language-oriented programming* was originally applied to F# by Robert Pickering in the Apress book *Beginning F#*, and it really captures a key facet of F# programming. Thanks, Robert!

---

## Computation Expressions

Chapter 3 introduced a useful notation for generating sequences of data, called *sequence expressions*. For example:

---

```
> seq { for i in 0 .. 3 -> (i, i * i) };;
val it : seq<int * int> = seq [(0, 0); (1, 1); (2, 4); (3, 9)]
```

---

Sequence expressions are used extensively throughout this book. For example, Chapter 9 uses sequence expressions for a range of sequence-programming tasks.

Likewise, Chapter 11 introduced a useful notation for generating individual results *asynchronously*, meaning that the result of a computation is eventually delivered to a continuation, a form of *future*, *task*, or *promise*. Asynchronous computations can also represent actions that do not “block” .NET threads when waiting for I/O. For example, consider the body of an agent from Chapter 11, which asynchronously waits for a message and then recursively loops—this is a form of asynchronous state machine.

```
let rec loop n =
    async { printfn "n = %d, waiting..." n
            let! msg = inbox.Receive()
            return! loop (n + msg) }
```

It turns out that both sequence expressions and asynchronous expressions are just two instances of a more general construct called *computation expressions*. These are also sometimes called *workflows*, although they bear only a passing similarity to the workflows used to model business processes. The general form of a computation expression is `builder { comp-expr }`. Table 17-1 shows the primary constructs that can be used within the braces of a computation expression and how these constructs are de-sugared by the F# compiler given a computation expression builder `builder`.

The three most important applications of computation expressions in F# programming are:

- General-purpose programming with sequences, lists, and arrays
- Parallel, asynchronous, and concurrent programming using asynchronous workflows, discussed in detail in Chapter 11
- Database queries, by quoting a workflow and translating it to SQL via the .NET LINQ libraries, a technique demonstrated in Chapter 13

This section covers briefly how computation expressions work through some simple examples.

**Table 17-1.** Main constructs in computation expressions and their ee-sugaring

Construct	De-sugared Form
<code>let pat = expr in cexpr</code>	<code>let pat = expr in "cexpr"</code>
<code>let! pat = expr in cexpr</code>	<code>b.Bind (expr, (fun pat -&gt; "cexpr"))</code>
<code>use val = expr in cexpr</code>	<code>b.Using(expr, (fun val -&gt; "cexpr"))</code>
<code>use! val = expr in cexpr</code>	<code>b.Bind (expr, (fun x -&gt; "use val = expr in cexpr"))</code>
<code>do expr in cexpr</code>	<code>expr; b.Delay (fun () -&gt; "cexpr")</code>
<code>do! expr in cexpr</code>	<code>b.Bind (expr, (fun () -&gt; "cexpr"))</code>
<code>for pat in expr do cexpr</code>	<code>b.For (expr, (fun pat -&gt; "cexpr"))</code>
<code>while expr do cexpr</code>	<code>b.While ((fun () -&gt; expr), b.Delay (fun () -&gt; "cexpr"))</code>
<code>try cexpr1 with val -&gt; expr2</code>	<code>b.TryWith(b.Delay(fun () -&gt; "cexpr1"), (fun val -&gt; "cexpr2"))</code>
<code>try cexpr finally expr</code>	<code>b.TryFinally(b.Delay(fun () -&gt; "cexpr"), (fun () -&gt; expr))</code>
<code>if expr then cexpr1 else cexpr2</code>	<code>if expr then "cexpr1" else "cexpr2"</code>
<code>if expr then cexpr cexpr1; cexpr2</code>	<code>if expr then "cexpr" else b.Zero() v.Combine ("cexpr1", b.Delay(fun () -&gt; "cexpr2"))</code>
<code>yield expr</code>	<code>b.Yield expr</code>
<code>yield! expr</code>	<code>b.YieldFrom expr</code>
<code>return expr</code>	<code>b.Return expr</code>
<code>return! expr</code>	<code>b.ReturnFrom expr</code>

■ **Note:** If you've never seen F# workflows or Haskell monads before, you might find that workflows take a bit of getting used to. They give you a way to write computations that may behave and execute quite differently than normal programs do.

## F# WORKFLOWS AND HASKELL MONADS

Computation expressions are the F# equivalent of monadic syntax in the programming language Haskell. Monads are a powerful and expressive design pattern; they are characterized by a generic type `M<'T>` combined with at least two operations:

```
bind : M<'T> -> ('T -> M<'U>) -> M<'U>
return : 'T -> M<'T>
```

These correspond to the primitives `let!` and `return` in the F# computation-expression syntax. Several other elements of the computation-expression syntax can be implemented in terms of these primitives, but the F# de-sugaring process leaves this up to the implementer of the workflow, because sometimes, derived operations can have more efficient implementations. Well-behaved monads should satisfy three important rules, called the *monad laws*.

F# uses the terms *computation expression* and *workflow* for four reasons:

- When the designers of F# talked with the designers of Haskell about this, they agreed that the word *monad* is obscure and sounds a little daunting and that using other names might be wise.
- There are some technical differences: for example, some F# workflows can be combined with imperative programming, utilizing the fact that workflows can have side effects that aren't tracked by the F# type system. In Haskell, all side-effecting operations must be lifted into the corresponding monad. The Haskell approach has some important advantages: you can know for sure what side effects a function can have by looking at its type. It also, however, makes it more difficult to use external libraries from within a computation expression.
- F# workflows can be reified using F# quotations, providing a way to execute the workflow by alternative means—for example, by translation to SQL. This gives them a different role in practice, because they can be used to model both concrete languages and computational languages.
- F# workflows can also be used to embed computations that generate multiple results (called *monoids*), such as sequence expressions (also known as *comprehension syntax*). These generally use `yield` and `yield!` instead of `return` and `return!` and often have no `let!`.

## An Example: Success/Failure Workflows

Perhaps the simplest kind of workflow is one in which failure of a computation is made explicit: for example, in which each step of the workflow may either *succeed*, by returning a result `Some(v)`, or *fail*, by returning the value `None`. You can model such a workflow using functions of type `unit -> 'T option`—that is, functions that may or may not compute a result. In this section, assume that these functions are pure and terminating: they have no side effects, raise no exceptions, and always terminate.

Whenever you define a new kind of workflow, it's useful to give a name to the type of values/objects generated by that workflow. In this case, let's call them `Attempt` objects:

```
type Attempt<'T> = (unit -> 'T option)
```

Of course, you can use regular functional programming to start to build `Attempt<'T>` objects:

```
let succeed x = (fun () -> Some(x)) : Attempt<'T>
let fail = (fun () -> None) : Attempt<'T>
let runAttempt (a : Attempt<'T>) = a()
```

These conform to the types:



---

```

val succeed : x:'T -> Attempt<'T>
val fail : Attempt<'T>
val runAttempt : a:Attempt<'T> -> 'T option

```

---

Using only normal F# expressions to build Attempt values can be a little tedious and lead to a proliferation of many different functions that stitch together Attempt values in straightforward ways. Luckily, as you've seen with sequence expressions, F# comes with predefined syntax for building objects such as Attempt values. You can use this syntax with a new type by defining a *builder* object that helps stitch together the fragments that make up the computation expression. Here's an example of the signature of an object you have to define in order to use workflow syntax with a new type (note that this is a type signature for an object, not actual code—we show how to define the AttemptBuilder type and its members later in this section):

---

```

type AttemptBuilder =
    member Bind : p:Attempt<'T> * ('T -> Attempt<'U>) -> Attempt<'U>
    member Delay : f:(unit -> Attempt<'T>) -> Attempt<'T>
    member Return : x:'T -> Attempt<'T>
    member ReturnFrom : x:Attempt<'T> -> Attempt<'T>

```

---

Typically, there is one global instance of each such builder object. For example:

```
let attempt = new AttemptBuilder()
```

---

```
val attempt : AttemptBuilder
```

---

First, let's see how you can use the F# syntax for workflows to build Attempt objects. You can build Attempt values that always succeed:

---

```

> let alwaysOne = attempt { return 1 };;
val alwaysOne : Attempt<int>
> let alwaysPair = attempt { return (1,"two") };;
val alwaysPair : Attempt<int * string>
> runAttempt alwaysOne;;
val it : int option = Some 1
> runAttempt alwaysPair;;
val it : (int * string) option = Some (1, "two")

```

---

Note that Attempt values such as alwaysOne are just functions; to run an Attempt value, just apply it. These correspond to uses of the succeed function, as you will see shortly.

You can also build more interesting Attempt values that check a condition and return different Attempt values on each branch, as shown in this example:

---

```

> let failIfBig n = attempt {if n > 1000 then return! fail else return n};;

val failIfBig : n:int -> Attempt<int>

> runAttempt (failIfBig 999);;

val it : int option = Some 999

> runAttempt (failIfBig 1001);;

val it : int option = None

```

---

Here, one branch uses `return!` to return the result of running another `Attempt` value, and the other uses `return` to give a single result. These correspond to `yield!` and `yield` in sequence expressions.

Next, you can build `Attempt` values that sequence together two `Attempt` values by running one, getting its result, binding it to a variable, and running the second. You do this by using the syntax form `let! pat = expr`, which is unique to computation expressions:

---

```

> let failIfEitherBig (inp1, inp2) = attempt {
    let! n1 = failIfBig inp1
    let! n2 = failIfBig inp2
    return (n1, n2)};;

val failIfEitherBig : inp1:int * inp2:int -> Attempt<int * int>

> runAttempt (failIfEitherBig (999, 998));;

val it : (int * int) option = Some (999, 998)

runAttempt (failIfEitherBig (1003, 998));;

val it : (int * int) option = None

> runAttempt (failIfEitherBig (999, 1001));;

val it : (int * int) option = None

```

---

Let's look at this more closely. First, what does the first `let!` do? It runs the `Attempt` value `failIfBig inp1`, and if this returns `None`, the whole computation returns `None`. If the computation on the right delivers a value (that is, returns `Some`), then it binds the result to the variable `n1` and continues. Note the following for the expression `let! n1 = failIfBig inp1`:

- The expression on the right (`failIfBig inp1`) has type `Attempt<int>`.
- The variable on the left (`n1`) is of type `int`.

This is somewhat similar to a sequence of normal `let` binding, but `let!` also controls whether the rest of the computation is executed. In the case of the `Attempt` type, it executes the rest of the computation only when it receives a `Some` value. Otherwise, it returns `None`, and the rest of the code is never executed.

You can use normal `let` bindings in computation expressions. For example:

```
let sumIfBothSmall (inp1, inp2) =
  attempt { let! n1 = failIfBig inp1
            let! n2 = failIfBig inp2
            let sum = n1 + n2
            return sum}
```

In this case, the `let` binding executes exactly as you would expect; it takes the expression `n1+n2` and binds its result to the value `sum`. To summarize, you've seen that computation expressions let you:

- Use an expression-like syntax to build `Attempt` computations
- Sequence these computations together using the `let!` construct
- Return results from these computations using `return` and `return!`
- Compute intermediate results using `let`

Workflows let you do a good deal more than this, as you will see in the sections that follow.

## Defining a Workflow Builder

Listing 17-1 shows the implementation of the workflow builder for `Attempt` workflows; this is the simplest definition for `AttemptBuilder`.

### *Listing 17-1. Defining a workflow builder*

```
let succeed x = (fun () -> Some(x))
let fail = (fun () -> None)
let runAttempt (a : Attempt<'T>) = a()
let bind p rest = match runAttempt p with None -> fail | Some r -> (rest r)
let delay f = (fun () -> runAttempt (f()))
let combine p1 p2 = (fun () -> match p1() with None -> p2() | res -> res)

type AttemptBuilder() =

    /// Used to de-sugar uses of 'let!' inside computation expressions.
    member b.Bind(p, rest) = bind p rest

    /// Delays the construction of an attempt until just before it is executed
    member b.Delay(f) = delay f

    /// Used to de-sugar uses of 'return' inside computation expressions.
    member b.Return(x) = succeed x

    /// Used to de-sugar uses of 'return!' inside computation expressions.
    member b.ReturnFrom(x : Attempt<'T>) = x

    /// Used to de-sugar uses of 'c1; c2' inside computation expressions.
    member b.Combine(p1 : Attempt<'T>, p2 : Attempt<'T>) = combine p1 p2

    /// Used to de-sugar uses of 'if .. then ..' inside computation expressions when
    /// the 'else' branch is empty
    member b.Zero() = fail

let attempt = new AttemptBuilder()
```

The inferred types here are:

---

```

type AttemptBuilder =
  class
    new : unit -> AttemptBuilder
    member Bind : p:Attempt<'T> * rest:(('T -> Attempt<'U>) -> Attempt<'U>)
    member Combine : p1:Attempt<'T> * p2:Attempt<'T> -> Attempt<'T>
    member Delay : f:(unit -> Attempt<'T>) -> Attempt<'T>
    member Return : x:'T -> Attempt<'T>
    member ReturnFrom : x:Attempt<'T> -> Attempt<'T>
    member Zero : unit -> Attempt<'T>
  end

val attempt : AttemptBuilder

```

---

F# implements workflows by de-sugaring computation expressions using a builder. For example, given the previous `AttemptBuilder`, the workflow

```

attempt { let! n1 = failIfBig inp1
          let! n2 = failIfBig inp2
          let sum = n1 + n2
          return sum}

```

de-sugars to

```

attempt.Bind(failIfBig inp1, (fun n1 ->
  attempt.Bind(failIfBig inp2, (fun n2 ->
    let sum = n1 + n2
    attempt.Return sum))))

```

One purpose of the F# workflow syntax is to make sure you don't have to write this sort of thing by hand. The de-sugaring of the workflow syntax is implemented by the F# compiler. Table 17-2 shows some of the typical signatures that a workflow builder needs to implement.

**Table 17-2.** Some typical Workflow-builder members as required by the F# compiler

Member	Description
member Bind : M<'T> * ('T -> M<'U>) -> M<'U>	Used to de-sugar <code>let!</code> and <code>do!</code> within computation expressions.
member Return : 'T -> M<'T>	Used to de-sugar <code>return</code> within computation expressions.
member ReturnFrom : M<'T> -> M<'T>	Used to de-sugar <code>return!</code> within computation expressions.
member Delay : (unit -> M<'T>) -> M<'T>	Used to ensure that side effects within a computation expression are performed when expected.
member For : seq<'T> * ('T -> M<'U>) -> M<'U>	Used to de-sugar <code>for ... do ...</code> within computation expressions. <code>M&lt;'U&gt;</code> can optionally be <code>M&lt;unit&gt;</code> .
member While : (unit -> bool) * M<'T> -> M<'T>	Used to de-sugar <code>while ... do ...</code> within computation expressions. <code>M&lt;'T&gt;</code> may optionally be <code>M&lt;unit&gt;</code> .

---

Member	Description
member Using : 'T * ('T -> M<'T>) -> M<'T> when 'T :> IDisposable	Used to de-sugar use bindings within computation expressions.
member Combine : M<'T> * M<'T> -> M<'T>	Used to de-sugar sequencing within computation expressions. The first M<'T> may optionally be M<unit>.
member Zero : unit -> M<'T>	Used to de-sugar empty else branches of if/then constructs within computation expressions.

Most of the elements of a workflow builder are usually implemented in terms of simpler primitives. For example, assume you're defining a workflow builder for some type M<'T> and you already have implementations of functions bindM and returnM with the types:

```
val bindM : M<'T> -> ('T -> M<'U>) -> M<'U>
val returnM : 'T -> M<'T>
```

You can implement Delay using the functions:

```
let delayM f = bindM (returnM ()) f
```

You can now define an overall builder in terms of all four functions:

```
type MBuilder() =
    member b.Return(x) = returnM x
    member b.Bind(v, f) = bindM v f
    member b.Delay(f) = delayM f
```

Let and Delay may also have more efficient direct implementations, however, which is why F# doesn't insert the previous implementations automatically.

## Workflows and Untamed Side Effects

It's possible, and in some cases even common, to define workflows that cause side effects. For example, you can use printfn in the middle of an Attempt workflow:

```
let sumIfBothSmall (inp1, inp2) =
    attempt { let! n1 = failIfBig inp1
              printfn "Hey, n1 was small!"
              let! n2 = failIfBig inp2
              printfn "n2 was also small!"
              let sum = n1 + n2
              return sum }
```

Here's what happens when you call this function:

```
> runAttempt(sumIfBothSmall (999, 999));;
```

```
Hey, n1 was small!
n2 was also small!
val it : int option = Some 1998
```

```
> runAttempt(sumIfBothSmall (999, 999));
```

```
Hey, n1 was small!
```

```
val it : int option = None
```

---

Side effects in workflows must be used with care, particularly because workflows are typically used to construct delayed or on-demand computations. In the previous example, printing is a fairly benign side effect. More significant side effects, such as mutable state, can also be sensibly combined with some kinds of workflows, but be sure you understand how the side effect will interact with the particular kind of workflow you're using. This example allocates a piece of mutable state that is local to the Attempt workflow, and this is used to accumulate the sum:

```
let sumIfBothSmall (inp1, inp2) =
  attempt { let sum = ref 0
            let! n1 = failIfBig inp1
            sum := sum.Value + n1
            let! n2 = failIfBig inp2
            sum := sum.Value + n2
            return sum.Value }
```

We leave it as an exercise for you to examine the de-sugaring of this workflow to see that the mutable reference is indeed local, in the sense that it doesn't escape the overall computation and that different executions of the same workflow use different reference cells.

As mentioned, workflows are nearly always delayed computations. As you saw in Chapter 4, delayed computations and side effects can interact. For this reason, the de-sugaring of workflow syntax inserts a Delay operation around the entire workflow. This

```
let printThenSeven = attempt { printf "starting..."; return 3 + 4 }
de-sugars to
let printThenSeven = attempt.Delay(fun () -> printf "starting..."; attempt.Return(3 + 4))
```

This means that “starting...” is printed each time the printThenSeven attempt object is executed.

## Computation Expressions with Custom Query Operators

F# 3.0 includes a set of extensions to computation expressions that allow builders to define additional “custom operators” associated with a computation-expression builder. This is particularly used to define query-like languages that progressively add constraints, sorting, and other declarations to a query. For example, we can change the “Attempt” builder above to use a custom query operator “condition” (to replace if/then):

```
type Attempt<'T> = (unit -> 'T option)
let succeed x = (fun () -> Some(x))
let fail = (fun () -> None)
let runAttempt (a : Attempt<'T>) = a()
let bind p rest = match runAttempt p with None -> fail | Some r -> (rest r)
let delay f = (fun () -> runAttempt (f()))
let condition p guard = (fun () ->
  match p() with
  | Some x when guard x -> Some x
```

```

| _ -> None)

type AttemptBuilder() =
    member b.Return(x) = succeed x
    member b.Bind(p, rest) = bind p rest
    member b.Delay(f) = delay f

    [<CustomOperation("condition",MaintainsVariableSpaceUsingBind = true)>]
    member x.Condition(p, [<ProjectionParameter>] b) = condition p b

let attempt = new AttemptBuilder()

```

Note that custom operations are declared using the `CustomOperation` attribute. Loosely speaking, a custom operation gets to operate on the “whole” computation—any values already declared in the computation expression are packaged up into a tuple, the operation is applied, and the values are then unpackaged. The technique used to package/unpackage is either “return/let!” (`MaintainsVariableSpaceUsingBind` is true), or “yield/for” (`MaintainsVariableSpaceUsingBind` is false). Parameters to custom operations can access the variables defined in the computation expression through the `ProjectionParameter` attribute.

For example, a workflow to generate a pair of random numbers in the unit circle is:

```

let randomNumberInCircle =
    attempt { let x, y = rand(), rand()
              condition (x * x + y * y < 1.0)
              return (x, y) }

```

Note that this is simply an alternative to an if/then expression. For F# 3.0, you must use either “control flow” operators, such as if/then/else, or “custom” operators, such as `condition`, in your own computation expressions. Attempts to combine these are unlikely to be satisfying.

Custom operators are very rarely defined in F# 3.0 programming and are primarily for use with F# 3.0 query expressions, used in Chapter 13.

## Example: Probabilistic Workflows

Workflows provide a fascinating way to embed a range of nontrivial, nonstandard computations into F#. To give you a feel for this, this section defines a *probabilistic* workflow. That is, instead of writing expressions to compute, say, integers, you instead write expressions that compute *distributions* of integers. This case study is based on a paper by Ramsey and Pfeffer from 2002.

For the purposes of this section, you’re interested in distributions over discrete domains characterized by three things:

- You want to be able to sample from a distribution (for example, sample an integer or a coin flip).
- You want to compute the support of a distribution: that is, a set of values in which all elements outside the set have zero chance of being sampled.
- You want to compute the expectation of a function over the distribution. For example, you can compute the probability of selecting element A by evaluating the expectation of the function (`fun x -> if x = A then 1.0 else 0.0`).

You can model this notion of a distribution with abstract objects. Listing 17-2 shows the definition of a type of distribution values and an implementation of the basic primitives `always` and `coinFlip`, which help build distributions.

*Listing 17-2. Implementing probabilistic modeling using computation expressions*

```
type Distribution<'T when 'T : comparison> =
    abstract Sample : 'T
    abstract Support : Set<'T>
    abstract Expectation: ('T -> float) -> float

let always x =
    { new Distribution<'T> with
        member d.Sample = x
        member d.Support = Set.singleton x
        member d.Expectation(H) = H(x) }

let rnd = System.Random()

let coinFlip (p : float) (d1 : Distribution<'T>) (d2 : Distribution<'T>) =
    if p < 0.0 || p > 1.0 then failwith "invalid probability in coinFlip"
    { new Distribution<'T> with
        member d.Sample =
            if rnd.NextDouble() < p then d1.Sample else d2.Sample
        member d.Support = Set.union d1.Support d2.Support
        member d.Expectation(H) =
            p * d1.Expectation(H) + (1.0 - p) * d2.Expectation(H) }
```

The types of these primitives are:

---

```
type Distribution<'T when 'T : comparison> =
    interface
        abstract member Expectation : ('T -> float) -> float
        abstract member Sample : 'T
        abstract member Support : Set<'T>
    end

val always : x:'T -> Distribution<'T> when 'T : comparison
val coinFlip :
    p:float -> d1:Distribution<'T> -> d2:Distribution<'T> -> Distribution<'T>
    when 'T : comparison
```

---

The simplest distribution is `always x`; this is a distribution that always samples to the same value. Its expectation and support are easy to calculate. The expectation of a function `H` is just `H` applied to the value, and the support is a set containing the single value `x`. The next distribution defined is `coinFlip`, which is a distribution that models the ability to choose between two outcomes.

Listing 17-3 shows how you can define a workflow builder for distribution objects.

*Listing 17-3. Defining a builder for probabilistic modeling using computation expressions*

```
let bind (dist : Distribution<'T>) (k : 'T -> Distribution<'U>) =
    { new Distribution<'U> with
```



```

    member d.Sample =
      (k dist.Sample).Sample
    member d.Support =
      Set.unionMany (dist.Support |> Set.map (fun d -> (k d).Support))
    member d.Expectation H =
      dist.Expectation(fun x -> (k x).Expectation H) }

type DistributionBuilder() =
  member x.Delay f = bind (always ()) f
  member x.Bind(d, f) = bind d f
  member x.Return v = always v
  member x.ReturnFrom vs = vs

let dist = new DistributionBuilder()

```

The types of these primitives are:

---

```

val bind :
  dist:Distribution<'T> -> k:(('T -> Distribution<'U>) -> Distribution<'U>
  when 'T : comparison and 'U : comparison val dist: DistributionBuilder

```

---

Listing 17-4 shows the all-important `bind` primitive; it combines two distributions, using the sample from the first to guide the sample from the second. The support and expectation are calculated by taking the support from the first and splaying it over the support of the second. The expectation is computed by using the first distribution to compute the expectation of a function derived from the second. These are standard results in probability theory, and they are the basic machinery you need to get going with some interesting modeling.

Before you begin using workflow syntax, you define two derived functions to compute distributions. Listing 17-4 shows the additional derived operations for distribution objects that you use later in this example.

**Listing 17-4.** *Defining the derived operations for probabilistic modeling using computation expressions*

```

let weightedCases (inp : ('T * float) list) =
  let rec coinFlips w l =
    match l with
    | [] -> failwith "no coinFlips"
    | [(d, _) ] -> always d
    | (d, p) :: rest -> coinFlip (p / (1.0 - w)) (always d) (coinFlips (w + p) rest)
  coinFlips 0.0 inp

let countedCases inp =
  let total = Seq.sumBy (fun (_, v) -> v) inp
  weightedCases (inp |> List.map (fun (x, v) -> (x, float v / float total)))

```

The two functions `weightedCases` and `countedCases` build distributions from the weighted selection of a finite number of cases. The types are:

---

```

val weightedCases :
  inp:(('T * float) list -> Distribution<'T> when 'T : comparison
val countedCases :
  inp:(('a * int) list -> Distribution<'a> when 'a : comparison

```

---

For example, here is the distribution of outcomes on a fair European roulette wheel:

```
type Outcome = Even | Odd | Zero
let roulette = countedCases [ Even,18; Odd,18; Zero,1]
```

You can now use sampling to draw from this distribution:

---

```
> roulette.Sample;;
val it : Outcome = Even

> roulette.Sample;;
val it : Outcome = Odd
```

---

You can compute the expected payout of a \$5 bet on Even, where you would get a \$10 return:

---

```
> roulette.Expectation (function Even -> 10.0 | Odd -> 0.0 | Zero -> 0.0);;

val it : float = 4.864864865
```

---

Now, let's model another scenario. Let's say you have a traffic light with the following probability distribution for showing red/yellow/green:

```
type Light =
  | Red
  | Green
  | Yellow

let trafficLightD = weightedCases [Red, 0.50; Yellow, 0.10; Green, 0.40]
```

Drivers are defined by their behavior with respect to a traffic light. For example, a cautious driver is highly likely to brake on a yellow light and always stops on a red:

```
type Action = Stop | Drive

let cautiousDriver light =
  dist { match light with
        | Red -> return Stop
        | Yellow -> return! weightedCases [Stop, 0.9; Drive, 0.1]
        | Green -> return Drive}
```

An aggressive driver is unlikely to brake on yellow and may even go through a red light:

```
let aggressiveDriver light =
  dist { match light with
        | Red -> return! weightedCases [Stop, 0.9; Drive, 0.1]
        | Yellow -> return! weightedCases [Stop, 0.1; Drive, 0.9]
        | Green -> return Drive}
```

This gives the value of the light showing in the other direction:

```
let otherLight light =
  match light with
  | Red -> Green
  | Yellow -> Red
  | Green -> Red
```

You can now model the probability of a crash between two drivers given a traffic light. Assume there is a 10 percent chance that two drivers going through the intersection will avoid a crash:

```
type CrashResult = Crash | NoCrash

// Where the suffix D means distribution
let crash (driverOneD, driverTwoD, lightD) =
  dist { // Sample from the traffic light
    let! light = lightD

    // Sample the first driver's behavior given the traffic light
    let! driverOne = driverOneD light

    // Sample the second driver's behavior given the traffic light
    let! driverTwo = driverTwoD (otherLight light)

    // Work out the probability of a crash
    match driverOne, driverTwo with
    | Drive, Drive -> return! weightedCases [Crash, 0.9; NoCrash, 0.1]
    | _ -> return NoCrash}
```

You can now instantiate the model to a cautious/aggressive driver pair, sample the overall model, and compute the overall expectation of a crash as approximately 3.7 percent:

---

```
> let model = crash (cautiousDriver, aggressiveDriver, trafficLightD);;

val model : Distribution<CrashResult>

> model.Sample;;

val it : CrashResult = NoCrash
...
> model.Sample;;

val it : CrashResult = Crash

> model.Expectation (function Crash -> 1.0 | NoCrash -> 0.0);;

val it : float = 0.0369
```

---

■ **Note:** This section showed how to define a simplistic embedded *computational probabilistic modeling language*. There are many more efficient and sophisticated techniques to apply to the description, evaluation, and analysis of probabilistic models than those shown here, and you can make the implementation of the primitives shown here more efficient by being more careful about the underlying computational representations.

---

## Combining Workflows and Resources

In some situations, workflows can sensibly make use of transient resources, such as files. The tricky thing is that you still want to be careful about closing and disposing of resources when the workflow is complete or when it's no longer being used. For this reason, the workflow type must be carefully designed to correctly dispose of resources halfway through a computation, if necessary. This is useful, for example, in sequence expressions, such as this one that opens a file and reads lines on demand:

```
let linesOfFile(fileName) =
    seq { use textReader = System.IO.File.OpenText(fileName)
          while not textReader.EndOfStream do
              yield textReader.ReadLine() }
```

Chapter 4 discussed the construct `use pat = expr`. As shown in Table 17-2, you can also use this construct within workflows. In this case, the `use pat = expr` construct de-sugars into a call to `seq.Using`. In the case of sequence expressions, this function is carefully implemented to ensure that `textReader` is kept open for the duration of the process of reading from the file. Furthermore, the `Dispose` function on each generated `IEnumerator` object for a sequence calls the `textReader.Dispose()` method. This ensures that the file is closed even if you enumerate only half of the lines in the file. Workflows thus allow you to scope the lifetime of a resource over a delayed computation.

## Recursive Workflow Expressions

Like functions, workflow expressions can be defined recursively. Many of the best examples are generative sequences. For example:

```
let rnd = System.Random()

let rec randomWalk k =
    seq { yield k
          yield! randomWalk (k + rnd.NextDouble() - 0.5) }
```

---

```
> randomWalk 10.0;;
```

```
val it : seq<float> = seq [10.0; 10.44456912; 10.52486359; 10.07400056; ...]
```

```
> randomWalk 10.0;;
```

```
val it : seq<float> = seq [10.0; 10.03566833; 10.12441613; 9.922847582; ...]
```

---

## Using F# Reflection

The final topics in this chapter are *F# quotations*, which provide a way to get at a representation of F# expressions as abstract syntax trees, and *reflection*, which lets you get at representations of assemblies, type definitions, and member signatures. Let's look at reflection first.

## Reflecting on Types

One of the simplest uses of reflection is to access the representation of types and generic type variables using the `typeof` operator. For example, `typeof<int>` and `typeof<'T>` are both expressions that generate values of type `System.Type`. Given a `System.Type` value, you can use the .NET APIs to access the `System.Reflection.Assembly` value that represents the .NET assembly that contains the definition of the type (.NET assemblies are described in Chapter 19). You can also access other types in the `System.Reflection` namespace, such as `MethodInfo`, `PropertyInfo`, `MemberInfo`, and `ConstructorInfo`. The following example examines the names associated with some common types:

---

```
> let intType = typeof<int>;;

val intType : System.Type = System.Int32

> intType.FullName;;

val it : string = "System.Int32"

> intType.AssemblyQualifiedName;;

val it : string =
  "System.Int32, mscorlib, Version=4.0.0.0, Culture=neutral, PublicKeyToken=b77a5c561934e089"

> let intListType = typeof<int list>;;

val intListType : System.Type =
  Microsoft.FSharp.Collections.FSharpList'1[System.Int32]

> intListType.FullName;;

val it : string =
  "Microsoft.FSharp.Collections.FSharpList'1[[System.Int32, mscorlib, Version=4.0.0.0, Culture=neutral, PublicKeyToken=b77a5c561934e089]]"
```

---

## Schema Compilation by Reflecting on Types

The F# library includes the namespace `Microsoft.FSharp.Reflection`, which contains types and functions that extend the functionality of the `System.Reflection` namespace of .NET.

You can use the combination of .NET and F# reflection to provide generic implementations of language-related transformations. This section gives one example of this powerful technique. Listing 17-5 shows the definition of a *generic schema reader compiler*, in which a data schema is described using F# types and the schema compiler helps convert untyped data from comma-separated value text files into this data schema.

*Listing 17-5. Using Types and Attributes to Guide Dynamic Schema Compilation*

```
open System
open System.IO
open System.Globalization
open Microsoft.FSharp.Reflection
```

```

/// An attribute to be added to fields of a schema record type to indicate the
/// column used in the data format for the schema.
type ColumnAttribute(col : int) =
    inherit Attribute()
    member x.Column = col

/// SchemaReader builds an object that automatically transforms lines of text
/// files in comma-separated form into instances of the given type 'Schema.
/// 'Schema must be an F# record type where each field is attributed with a
/// ColumnAttribute attribute, indicating which column of the data the record
/// field is drawn from. This simple version of the reader understands
/// integer, string and DateTime values in the CSV format.
type SchemaReader<'Schema>() =

    // Grab the object for the type that describes the schema
    let schemaType = typeof<'Schema>

    // Grab the fields from that type
    let fields = FSharpType.GetRecordFields(schemaType)

    // For each field find the ColumnAttribute and compute a function
    // to build a value for the field
    let schema =
        fields |> Array.mapi (fun fldIdx fld ->
            let fieldInfo = schemaType.GetProperty(fld.Name)
            let fieldConverter =
                match fld.PropertyType with
                | ty when ty = typeof<string> -> (fun (s : string) -> box s)
                | ty when ty = typeof<int> -> (System.Int32.Parse >> box)
                | ty when ty = typeof<DateTime> ->
                    (fun s -> box (DateTime.Parse(s, CultureInfo.InvariantCulture))))
                | ty -> failwithf "Unknown primitive type %A" ty

            let attrib =
                match fieldInfo.GetCustomAttributes(typeof<ColumnAttribute>, false) with
                | [:(? ColumnAttribute as attrib)] -> attrib
                | _ -> failwithf "No column attribute found on field %s" fld.Name
                (fldIdx, fld.Name, attrib.Column, fieldConverter))

    // Compute the permutation defined by the ColumnAttribute indexes
    let columnToFldIdxPermutation c =
        schema |> Array.pick (fun (fldIdx, _, colIdx, _) ->
            if colIdx = c then Some fldIdx else None)

    // Drop the parts of the schema we don't need
    let schema =
        schema |> Array.map (fun (_, fldName, _, fldConv) -> (fldName, fldConv))

    // Compute a function to build instances of the schema type. This uses an
    // F# library function.
    let objectBuilder = FSharpValue.PreComputeRecordConstructor(schemaType)

```

```
// OK, now we're ready to implement a line reader
member reader.ReadLine(textReader : TextReader) =
  let line = textReader.ReadLine()
  let words = line.Split(['|','|']) |> Array.map(fun s -> s.Trim())
  if words.Length <> schema.Length then
    failwith "unexpected number of columns in line %s" line
  let words = words |> Array.permute columnToFldIdxPermutation

  let convertColumn colText (fieldName, fieldConverter) =
    try fieldConverter colText
    with e ->
      failwithf "error converting '%s' to field '%s'" colText fieldName

  let obj = objectBuilder (Array.map2 convertColumn words schema)

// OK, now we know we've dynamically built an object of the right type
unbox<'Schema>(obj)

/// This reads an entire file
member reader.ReadFile(file) =
  seq { use textReader = File.OpenText(file)
        while not textReader.EndOfStream do
          yield reader.ReadLine(textReader) }
```

The type of the SchemaReader is simple:

---

```
type SchemaReader<'Schema> =
  class
    new : unit -> SchemaReader<'Schema>
    member ReadFile : file:string -> seq<'Schema>
    member ReadLine : textReader:System.IO.TextReader -> 'Schema
  end
```

---

First, see how the SchemaReader is used in practice. Let's say you have a text file containing lines such as:

```
Steve, 12 March 2010, Cheddar
Sally, 18 Feb 2010, Brie
...
```

It's reasonable to want to convert this data to a typed data representation. You can do this by defining an appropriate record type along with enough information to indicate how the data in the file map into this type. This information is expressed using *custom attributes*, which are a way to add extra meta-information to assembly, type, member, property, and parameter definitions. Each custom attribute is specified as an instance of a typed object, here `ColumnAttribute`, defined in Listing 17-5. The suffix `Attribute` is required when defining custom attributed but can be dropped when using them:

```
type CheeseClub =
  { [

```

You can now instantiate the `SchemaReader` type and use it to read the data from the file into this typed format:

---

```
> let reader = new SchemaReader<CheeseClub>();

val reader : SchemaReader<CheeseClub>

> fsi.AddPrinter(fun (c : System.DateTime) -> c.ToString());;
> System.IO.File.WriteAllLines("data.txt",
    [|"Steve, 12 March 2010, Cheddar"; "Sally, 18 Feb 2010, Brie"|]);;

> reader.ReadFile("data.txt");;

val it : seq<CheeseClub>
= seq
    [{Name = "Steve";
      FavouriteCheese = "Cheddar";
      LastAttendance = 12/03/2010 00:00:00;};
     {Name = "Sally";
      FavouriteCheese = "Brie";
      LastAttendance = 18/02/2010 00:00:00;}]
```

---

There is something somewhat magical about this; you've built a layer that automatically does the impedance matching between the untyped world of a text-file format into the typed world of F# programming. Amazingly, the `SchemaReader` type itself is only about 50 lines of code. The comments in Listing 17-5 show the basic steps being performed. The essential features of this technique are:

1. The schema information is passed to the `SchemaReader` as a type variable. The `SchemaReader` then uses the `typeof` operator to extract a `System.Type` representation of the schema type.
2. The information needed to drive the transformation process comes from custom attributes. Extra information can also be supplied to the constructor of the `SchemaReader` type if necessary.
3. The `let` bindings of the `SchemaReader` type are effectively a form of precomputation (they can also be seen as a form of compilation). They precompute as much information as possible given the schema. For example, the section analyzes the fields of the schema type and computes functions for creating objects of the field types. It also computes the permutation from the text file columns to the record fields.
4. The data objects are ultimately constructed using reflection functions, in this case a function computed by `Microsoft.FSharp.Reflection.Value.GetRecordConstructor` or primitive values parsed using `System.Int32.Parse` and similar functions. This and other functions for creating F# objects dynamically are in the `Microsoft.FSharp.Reflection` library. Other functions for creating other .NET objects dynamically are in the `System.Reflection` library.
5. The member bindings of `SchemaReader` interpret the residue of the precomputation stage, in this case using the information and computed functions to process the results of splitting the text of a line.



This technique has many potential applications and has been used for CSV file reading, building F#-centric serializers/deserializers, and building generic strongly typed database schema access.

## Using the F# Dynamic Reflection Operators

F# lets you define two special operators, (?) and (?<-), to perform dynamic lookups of objects. These are conceptually very simple operators, but they add interesting new opportunities for interoperability between dynamic data and static data in F# programming.

These operators implicitly translate their second argument to a string, if it's a simple identifier. That is, a use of these operators is translated as:

```
expr ? nm           Ⓢ  (?) expr "nm"
expr1 ? nm <- expr2 Ⓢ  (?<-) expr1 "nm" expr2
```

This means that the operators can be used to simulate a dynamic lookup of a property or a method on an object. This dynamic lookup can use any dynamic/reflective technique available to you. One such technique is to use .NET reflection to look up and/or set the properties of an object:

```
open System.Reflection
```

```
let (?) (obj : obj) (nm : string) : 'T =
    obj.GetType().InvokeMember(nm, BindingFlags.GetProperty, null, obj, [||])
    |> unbox<'T>
```

```
let (?<-) (obj : obj) (nm : string) (v : obj) : unit =
    obj.GetType().InvokeMember(nm, BindingFlags.SetProperty, null, obj, [|v|])
    |> ignore
```

Now, you can use the operators to dynamically query data:

```
type Record1 = {Length : int; mutable Values : int list}
```

```
let obj1 = box [1; 2; 3]
let obj2 = box {Length = 4; Values = [3; 4; 5; 7]}
```

```
let n1 : int = obj1?Length
let n2 : int = obj2?Length
let valuesOld : int list = obj2?Values
```

Here, both `obj1` and `obj2` have type `obj`, but you can do dynamic lookups of the properties `Length` and `Values` using the `?` operator. Of course, these uses aren't strongly statically typed—this is why you need the type annotations `: int` and `: int list` to indicate the return type of the operation. Given the earlier definition of the `(?<-)` operator, you can also set a property dynamically::

```
obj2?Values <- [7; 8; 9]
let valuesNew : int list = obj2?Values
```

Using the `(?)` and `(?<-)` operators obviously comes with strong drawbacks: you lose considerable type safety, and performance may be affected by the use of dynamic techniques. Their use is recommended only when you're consistently interoperating with weakly typed objects, or when you continually find yourself doing string-based lookup of elements of an object.

## Using F# Quotations

The other side to reflective meta-programming in F# is *quotations*. These allow you to reflect over expressions in much the same way that you've reflected over types in the previous section. It's simple to get going with F# quotations; you open the appropriate modules and surround an expression with `<@ . . . @>` symbols:

---

```
> open Microsoft.FSharp.Quotations;;

> let oneExpr = <@ 1 @>;

val oneExpr : Expr<int> = Value (1)

> let plusExpr = <@ 1 + 1 @>;

val plusExpr : Expr<int> = Call (None, op_Addition, [Value (1), Value (1)])
```

---

You can see here that the act of quoting an expression gives you back the expression as data. Those familiar with Lisp or Scheme know a sophisticated version of this in the form of Lisp quotations, and those familiar with C# 3.0 will find it familiar, because C# uses similar mechanisms for its lambda expressions. F# quotations are distinctive partly because they're *typed* (like C# lambda expressions) and because the functional, expression-based nature of F# means that so much of the language can be quoted and manipulated relatively easily.

Chapter 13 uses F# queries that implicitly convert F# quotations to SQL via the .NET LINQ library. Perhaps the most important application is in Chapter 14, where quotations are converted to JavaScript when using WebSharper. This may be implemented by a function with a type such as

---

```
val CompileToJavaScript : Expr<'T> -> string
```

---



---

### WHAT ARE F# QUOTATIONS FOR?

---

The primary rationale for F# quotations is to allow fragments of F# syntax to be executed by alternative means: for example, as an SQL query via LINQ or by running on another device, such as a GPU or as JavaScript in a client-side Web browser. F# aims to leverage heavy-hitting external components that map subsets of functional programs to other execution machinery. Another example use involves executing a subset of F# array code by dynamic generation of Fortran code and invoking a high-performance vectorizing Fortran compiler. The generated DLL is loaded and invoked dynamically.

This effectively means that you can convert from a computational representation of a language (for example, regular F# functions and F# workflow expressions) to an abstract syntax representation of the same language. This is a powerful technique, because it lets you design using a computational model of the language (for example, sampling from a distribution or running queries against local data) and then switch to a more concrete abstract syntax representation of the same programs in order to analyze, execute, print, or compile those programs in other ways.

---

## Example: Using F# Quotations for Error Estimation

Listing 17-6 shows a prototypical use of quotations, in this case to perform error estimation on F# arithmetic expressions.

*Listing 17-6. Error analysis on F# expressions implemented with F# quotations*

```

open Microsoft.FSharp.Quotations
open Microsoft.FSharp.Quotations.Patterns
open Microsoft.FSharp.Quotations.DerivedPatterns

type Error = Err of float

let rec errorEstimateAux (e : Expr) (env : Map<Var, _>) =
    match e with
    | SpecificCall <@@ (+) @@> (tyargs, _, [xt; yt]) ->
        let x, Err(xerr) = errorEstimateAux xt env
        let y, Err(yerr) = errorEstimateAux yt env
        (x + y, Err(xerr + yerr))

    | SpecificCall <@@ (-) @@> (tyargs, _, [xt; yt]) ->
        let x, Err(xerr) = errorEstimateAux xt env
        let y, Err(yerr) = errorEstimateAux yt env
        (x - y, Err(xerr + yerr))

    | SpecificCall <@@ ( * ) @@> (tyargs, _, [xt; yt]) ->
        let x, Err(xerr) = errorEstimateAux xt env
        let y, Err(yerr) = errorEstimateAux yt env
        (x * y, Err(xerr * abs(y) + yerr * abs(x) + xerr * yerr))

    | SpecificCall <@@ abs @@> (tyargs, _, [xt]) ->
        let x, Err(xerr) = errorEstimateAux xt env
        (abs(x), Err(xerr))

    | Let(var, vet, bodyt) ->
        let varv, verr = errorEstimateAux vet env
        errorEstimateAux bodyt (env.Add(var, (varv, verr)))

    | Call(None, MethodWithReflectedDefinition(Lambda(v, body)), [arg]) ->
        errorEstimateAux (Expr.Let(v, arg, body)) env

    | Var(x) -> env.[x]

    | Double(n) -> (n, Err(0.0))

    | _ -> failwithf "unrecognized term: %A" e

let rec errorEstimateRaw (t : Expr) =
    match t with
    | Lambda(x, t) ->
        (fun xv -> errorEstimateAux t (Map.ofSeq [(x, xv)]))

```

```
| PropertyGet(None, PropertyGetterWithReflectedDefinition(body), []) ->
  errorEstimateRaw body
| _ -> failwithf "unrecognized term: %A - expected a lambda" t
```

```
let errorEstimate (t : Expr<float -> float>) = errorEstimateRaw t
```

The inferred types of the functions are:

---

```
type Error = | Err of float
val errorEstimateAux : e:Expr -> env:Map<Var,(float * Error)> -> float * Error
val errorEstimateRaw : t:Expr -> (float * Error -> float * Error)
val errorEstimate :
  t:Expr<(float -> float)> -> (float * Error -> float * Error)
```

---

That is, `errorEstimate` is a function that takes an expression for a `float -> float` function and returns a function value of type `float * Error -> float * Error`.

Let's see it in action. First, define the function `err` and a pretty-printer for `float * Error` pairs, here using the Unicode symbol for error bounds on a value:

---

```
> let err x = Err x;;

val err : x:float -> Error

> fsi.AddPrinter (fun (x : float, Err v) -> sprintf "%g±%g" x v);;
> errorEstimate <@ fun x -> x + 2.0 * x + 3.0 * x * x @> (1.0, err 0.1);;

val it : float * Error = 6±0.93

> errorEstimate <@ fun x -> let y = x + x in y * y + 2.0 @> (1.0, err 0.1);;

val it : float * Error = 6±0.84
```

---

The key aspects of the implementation of `errorEstimate` are:

- The `errorEstimate` function converts the input expression to a raw expression, which is an untyped abstract syntax representation of the expression designed for further processing. It then calls `errorEstimateRaw`. Traversals are generally much easier to perform using raw terms.
- The `errorEstimateRaw` function then checks that the expression given is a lambda expression, using the active pattern `Lambda` provided by the `Microsoft.FSharp.Quotations.Patterns` module.
- The `errorEstimateRaw` function then calls the auxiliary function `errorEstimateAux`. This function keeps track of a mapping from variables to value/error estimate pairs. It recursively analyzes the expression looking for `+`, `-`, `*` and `abs` operations. These are all overloaded operators and hence are called *generic functions* in F# terminology, so the function uses the active pattern `SpecificCall` to detect applications of these operators. At each point, it performs the appropriate error estimation.

- For variables, the environment map `env` is consulted. For constants, the error is zero.
- Two additional cases are covered in `errorEstimateAux` and `errorEstimateRaw`. The `Let` pattern allows you to include expressions of the form `let x = e1 in e2` in the subset accepted by the quotation analyzer. The `MethodWithReflectedDefinition` case allows you to perform analyses on some function calls, as you will see next.

## Resolving Reflected Definitions

One problem with meta-programming with explicit `<@ ... @>` quotation marks alone is that you can't analyze very large programs, because the entire expression to be analyzed must be delimited by these markers. This is solved in F# by allowing you to tag top-level `member` and `let` bindings as reflected. This ensures that their definitions are persisted to a table attached to their compiled DLL or EXE. These functions can also be executed as normal F# code. For example, here is a function whose definition is persisted:

```
[<ReflectedDefinition>]
let poly x = x + 2.0 * x + 3.0 * (x * x)
```

You can retrieve definitions such as this using the `MethodWithReflectedDefinition` and `PropertyGetterWithReflectedDefinition` active patterns, as shown in Listing 17-6. You can now use this function in a regular `<@ ... @>` quotation and thus analyze it for errors:

---

```
> errorEstimate <@ poly @> (3.0, err 0.1);;

val it : float * Error = 36±2.13
> errorEstimate <@ poly @> (30271.3, err 0.0001);;

val it : float * Error = 2.74915e+09±18.1631
```

---

## Summary

This chapter covered key topics in a programming paradigm, *language-oriented programming*, that is central to F#. In previous chapters, you saw some techniques for traversing abstract syntax trees. These language-representation techniques give you powerful ways to manipulate concrete and abstract syntax fragments.

In this chapter, you saw two language-representation techniques that are more tightly coupled to F#: F# computation expressions, which are useful for embedded computational languages involving sequencing, and F# quotations, which let you give an alternative meaning to existing F# program fragments. Along the way, the chapter touched on reflection and its use in mediating between typed and untyped representations.

In the next chapter, you'll look at some of the interoperability mechanisms that come with the .NET implementation of F#.

## CHAPTER 18



# Libraries and Interoperating with Other Languages

*Programming in different languages is like composing pieces in different keys, particularly if you work at the keyboard. If you have learned or written pieces in many keys, each key will have its own special emotional aura. Also, certain kinds of figurations “lie in the hand” in one key but are awkward in another. So you are channeled by your choice of key. In some ways, even enharmonic keys, such as C-sharp and D-flat, are quite distinct in feeling. This shows how a notational system can play a significant role in shaping the final product.*

Gödel, Escher, Bach: an eternal golden braid, Hofstadter, 1980, Chapter X

Software integration and reuse is becoming one of the most relevant activities in software development. This chapter discusses how F# programs can interoperate with the outside world, accessing code available from both .NET and other languages.

## Types, memory and interoperability

F# programs need to call libraries, even for the very basic tasks, such as printing or accessing files, and these libraries come in binary form as part of the Common Language Runtime (CLR), the piece of software responsible for running programs after compilation. Libraries can be, and have been, written using different programming languages, leveraging on the fact that the output of the compilation has a common format that the CLR uses for executing their code. Even considering just the core libraries, such as `microsoft.dll` (containing essential types such as `System.String`, the underlying type for the F# type `string`), most of the code has been written using C#.

You need to understand language interoperability, at least to some extent, to be a proficient F# programmer. There are four levels of interoperability to consider:

- F# library
- Non-F# .NET library
- COM library
- Binary DLL library

If a library has been compiled using the F# compiler and it is meant to be used from F#, everything feels like F#—types, modules, and functions are available as in F# source form, except for scope restrictions introduced by visibility clauses, such as `private`. The F# compiler, unless told otherwise, generates additional information into the binary files meant to be used when compiling other F# source files that depend on them.

---

■ **Note:** For more information about designing F# libraries to be used from other .NET languages, see the F# component design guidelines, available at <http://tinyurl.com/fs-component-design-guidelines>

---

In all the other cases, the problem is essentially the same: how to represent types defined in a library within F# so that their values can be safely accessed from the program. Sometimes a value can be accessed as is, accessing the single in-memory copy from F# generated code; otherwise, some form of *marshalling* is needed to convert a value from the library representation to one accessible from F#. Although simple in theory, sharing types and their values among different runtimes of programming languages results in many subtle issues in practice, with increasing complexity depending how close their runtime support is. Even a relatively simple type, such as the .NET string, has a memory representation very different from C.

.NET libraries compiled with languages other than F# and designed to be consumed from many .NET languages (i.e., designed according to the Common Language Specification, <http://tinyurl.com/dotnetCLS>, to define a subset of the .NET type system that can be safely shared among different programming languages) are easily accessible from F# programs in the form of a set of classes that can be instantiated and whose methods can be invoked. F# specific types, such as tuples or discriminated unions, are usually unavailable as type of method arguments; thus, you need some form of marshalling to convert F# types into simpler .NET types. Apart from these small issues, using these libraries is seamless, because the runtime is shared and the .NET binary format contains meta-information, such as the type structure, that can be used by compilers to spare many details related to interoperability.

COM components have been constituents of the Windows operating system and are still widely used for integrating binary components. Notorious ActiveX controls are, in fact, a kind of COM component capable of displaying a UI inside a host application. The CLR itself is exposed as a COM component, and it tightly couples with the COM infrastructure. The COM type system and memory management are less rich and safe than .NET, but type libraries and `IDispatch` interface approximate .NET reflection, and the CLR usually can wrap COM components as .NET types. COM is still underlying in some form to the newest WinRT API released by Microsoft for programming Windows 8-style applications.

C has been de facto standard for language interoperability for many years. CLR is capable of interoperating with C binary interfaces at the cost of manually annotating .NET types and, sometime, taking care explicitly of marshalling and memory handling.

This chapter explores the various levels of interoperability, giving an overview of the .NET libraries in the first place. An overview of the COM components is also given, with the goal of enabling F# programmers to consume these software units. Finally, the platform invoke API is introduced, showing how to link binary libraries and interacting with C code; this interface is part of the .NET ECMA standard and it is available on different CLR implementations, including Mono, the open-source implementation running on MacOS X and Linux.

## Libraries: A High-Level Overview

One way to get a quick overview of the .NET Framework and the F# library is to look at the primary DLLs and namespaces contained in them. Recall from Chapters 2 and 7 that DLLs correspond to the *physical* organization of libraries, and that namespaces and types give the *logical* organization of a naming

hierarchy. Let's look at the physical organization first. The types and functions covered in this chapter are drawn from the DLLs in Table 18-1.

*Table 18-1. DLLs containing the library constructs referred to in this chapter*

DLL Name	Notes
mscorlib.dll	Minimal system constructs, including the types in the System namespace.
System.dll	Additional commonly used constructs in namespaces, such as System and System.Text.
System.Xml.dll	See the corresponding namespace in Table 18-2.
System.Data.dll	See the corresponding namespace in Table 18-2.
System.Drawing.dll	See the corresponding namespace in Table 18-2.
System.Web.dll	See the corresponding namespace in Table 18-2.
System.Windows.Forms.dll	See the corresponding namespace in Table 18-2.
System.Core.dll	The foundation types for LINQ and some other useful types. From .NET 3.5 onward.
DLL Name	Notes
WindowsBase.dll	Core functionality for Windows Presentation Foundation.
PresentationCore.dll	Core functionality for Windows Presentation Foundation.
PresentationFramework.dll	Core functionality for Windows Presentation Foundation.
FSharp.Core.dll	Minimal constructs for F# assemblies.

To reference additional DLLs, you can embed a reference directly into your source code in F# scripting files that use .fsx extension. For example:

```
#I @"C:\Program Files\Reference Assemblies\Microsoft\Framework\v3.5";;
#r "System.Core.dll";;
```

The first line specifies an include path, the equivalent of the -I command-line option for the F# compiler. The second line specifies a DLL reference, the equivalent of the -r command-line option. Chapter 7 described these. If you're using Visual Studio, you can adjust the project property settings for your project.

---

■ **Note:** Hundreds of high-quality frameworks and libraries are available for .NET, and more are appearing all the time. For space reasons, this chapter covers only the .NET libraries and frameworks listed in Table 18-1. “Some Other .NET Libraries” lists some libraries you may find interesting.

---

## Namespaces from the .NET Framework

Table 18-2 shows the primary namespaces in .NET Framework DLLs from Table 18-1. In some cases, parts of these libraries are covered elsewhere in this book; the table notes these cases. For example, Chapter 4 introduced portions of the .NET I/O library from the System.IO namespace.



*Table 18-2. Namespaces in the DLLs from Table 18-1, with MSDN descriptions*

Namespace	Description
System	Types and methods that define commonly used value and reference data types, events and event handlers, interfaces, attributes, and processing exceptions, supporting data-type conversions, mathematics, application environment management, and runtime supervision of managed and unmanaged applications. See Chapter 3 for many of the basic types in this namespace.
System.CodeDom	Types that can be used to represent the elements and structure of a source-code document. Not covered in this book.
Namespace	Description
System.Collections	Types that define various nongeneric collections of objects, such as lists, queues, and bit arrays. Partially covered in “Using Further F# and .NET Data Structures” later in this chapter.
System.Collections.Generic	Types that define generic collections. See Chapter 4 and “Using Further F# and .NET Data Structures” later in this chapter.
System.ComponentModel	Types that are used to implement the runtime and design-time behavior of components and controls. See Chapter 16.
System.Configuration	Types that provide the programming model for handling configuration data.
System.Data	Types that represent the ADO.NET database access architecture. See Chapter 13.
System.Diagnostics	Types that allow you to interact with system processes, event logs, and performance counters. See Chapter 19.
System.Drawing	Types that allow access to GDI+ basic graphics functionality. More advanced functionality is provided in the <code>System.Drawing.Drawing2D</code> , <code>System.Drawing.Imaging</code> , and <code>System.Drawing.Text</code> namespaces. See Chapter 16.
System.Globalization	Types that define culture-related information, including the language, the country/region, the calendars in use, the format patterns for dates, the currency, the numbers, and the sort order for strings. Not covered in this book.
System.IO	Types that allow reading and writing files and data streams, as well as types that provide basic file and directory support. See Chapter 4 for a basic overview.
System.Media	Types for playing and accessing sounds and other media formats. Not covered in this book. .NET 3.0 and later.
System.Net	Types to programmatically access many of the protocols used on modern networks. See Chapters 2 and 14 for examples and a basic overview.
System.Reflection	Types that retrieve information about assemblies, modules, members, parameters, and other entities in managed code. See Chapter 17 for a brief overview.
System.Reflection.Emit	Types for generating .NET code dynamically at runtime.
System.Resources	Types that let you create, store, and manage various culture-specific resources used in an application. See Chapter 7 for a brief overview.

Namespace	Description
System.Security	Types to interface with the underlying structure of the CLR security system, including base classes for permissions. Not covered in this book.
System.Text	Types representing ASCII, Unicode, UTF-8, and other character encodings. Also abstract types for converting blocks of characters to and from blocks of bytes. See Chapter 3 and “Using Regular Expressions and Formatting” later in this chapter.
System.Threading	Types for creating and synchronizing threads and, in .NET 4.0, tasks. Also parallel operations and some functionality related to cancellation. See Chapter 11.
System.Web	Types that enable Web applications. See Chapter 14.
System.Windows.Forms	Types for creating windowed applications. See Chapter 16.
System.Xml	Types that implement standards-based support for processing XML. See Chapter 8.
Microsoft.Win32	Types that wrap Win32 API common dialog boxes and components. Not covered in this book.

## Namespaces from the F# Libraries

Table 18-3 shows the primary namespaces in F# library DLLs from Table 18-1. The following are opened by default in F# code:

```
Microsoft.FSharp.Core
Microsoft.FSharp.Collections
Microsoft.FSharp.Control
Microsoft.FSharp.Text
```

**Table 18-3.** Namespaces in the DLLs from Table 18-1

Namespace	Description
Microsoft.FSharp.Core	Provides primitive constructs related to the F# language, such as tuples. See Chapter 3.
Microsoft.FSharp.Collections	Provides functional programming collections, such as sets and maps implemented using binary trees. See Chapter 3 and “Using Further F# and .NET Data Structures” later in this chapter.
Namespace	Description
Microsoft.FSharp.Control	Provides functional programming control structures, including asynchronous and lazy programming. Chapter 11 covers programming with the <code>IEvent&lt;'T&gt;</code> type and the <code>IEvent</code> module, as well as the <code>Async&lt;'T&gt;</code> type.
Microsoft.FSharp.Text	Provides types for structured and <code>printf</code> -style textual formatting of data. See Chapter 4 for an introduction to <code>printf</code> formatting.
Microsoft.FSharp.Reflection	Provides extensions to the <code>System.Reflection</code> functionality that deal particularly with F# record and discriminated union values. See Chapter 17 for a brief introduction, and see “Further Libraries for Reflective Techniques” section later in this chapter for more details.
Microsoft.FSharp.Quotations	Provides access to F# expressions as abstract syntax trees. See Chapter 17.

## Using the System Types

Table 18-4 shows some of the most useful core types from the System namespace. These types are particularly useful because of the care and attention taken crafting them and the functionality they provide.

*Table 18-4. Useful core types from the System Namespace*

Function	Description
System.DateTime	A type representing a date and time
System.DayOfWeek	An enumeration type representing a day of the week
System.Decimal	A numeric type suitable for financial calculations requiring large numbers of significant integral and fractional digits and no round-off errors
System.Guid	A type representing a 128-bit globally unique ID
System.Nullable<'T>	A type with an underlying value type 'T' but that can be assigned null like a reference type
System.TimeSpan	A type representing a time interval
System.Uri	A type representing a uniform resource identifier (URI), such as an Internet URL

Many .NET types are used to hold static functions, such as those for converting data from one format to another. Types such as System.Random play a similar role via objects with a small amount of state. Table 18-5 shows some of the most useful of these types.

*Table 18-5. Useful services from the System Namespace*

Function	Description
System.BitConverter	Contains functions to convert numeric representations to and from bit representations
System.Convert	Contains functions to convert between various numeric representations
System.Math	Contains constants and static methods for trigonometric, logarithmic, and other common mathematical functions
System.Random	Provides objects to act as random-number generators
System.StringComparer	Provides objects implementing various types of comparisons on strings (case insensitive, and so on)

## Using Further F# and .NET Data Structures

As you saw in Chapter 2, F# comes with a useful implementation of some functional programming data structures. Recall that functional data structures are *persistent*: you can't mutate them, and if you add an element or otherwise modify the collection, you generate a new collection value, perhaps sharing some internal nodes but from the outside appearing to be a new value.

Table 18-6 summarizes the most important persistent functional data structures that are included in FSharp.Core.dll. It's likely that additional functional data structures will be added in future F# releases.

**Table 18-6.** *The F# Functional Data Structures from Microsoft.FSharp.Collections*

Type	Description
List<'T>	Immutable lists implemented using linked lists
Set<'T>	Immutable sets implemented using trees
Map<'Key, 'Value>	Immutable maps (dictionaries) implemented using trees
LazyList<'T>	Lists generated on demand, with each element computed only once

## System.Collections.Generic and Other .NET Collections

Table 18-7 summarizes the imperative collections available in the System.Collections.Generic namespace.

**Table 18-7.** *The .NET and F# imperative data structures from System.Collections.Generic*

Type	Description
List<'T>	Mutable, resizable integer-indexed arrays, usually called ResizeArray<'T> in F#.
SortedList<'T>	Mutable, resizable lists implemented using sorted arrays.
Dictionary<'Key, 'Value>	Mutable, resizable dictionaries implemented using hash tables.
SortedDictionary<'Key, 'Value>	Mutable, resizable dictionaries implemented using sorted arrays.
Queue<'T>	Mutable, first-in, first-out queues of unbounded size.
Stack<'T>	Mutable, first-in, last-out stacks of unbounded size.
HashSet<'T>	Mutable, resizable sets implemented using hash tables. New in .NET 3.5. The F# library also defines a Microsoft.FSharp.Collections.HashSet type usable in conjunction with earlier versions of .NET.

---

## SOME OTHER COLLECTION LIBRARIES

---

Two additional libraries of .NET collections deserve particular attention. The first is PowerCollections, currently provided by Wintellect. It provides additional generic types, such as Bag<'T>, MultiDictionary<'Key, 'Value>, OrderedDictionary<'Key, 'Value>, OrderedMultiDictionary<'T>, and OrderedSet<'T>. The second is the C5 collection library, provided by ITU in Denmark. It includes implementations of some persistent/functional data structures, such as persistent trees, that may be of particular interest for use from F#.

---

## Supervising and Isolating Execution

The .NET System namespace includes a number of useful types that provide functionality related to the execution of running programs in the .NET Common Language Runtime. Table 18-8 summarizes them.

**Table 18-8.** Types related to runtime supervision of applications

Function	Description
System.Runtime	Contains advanced types that support compilation and native interoperability
System.Environment	Provides information about, and the means to manipulate, the current environment and platform.
System.GC	Controls the system garbage collector. Garbage collection is discussed in more detail later in this chapter.
Function	Description
System.WeakReference	Represents a weak reference, which references an object while still allowing that object to be reclaimed by garbage collection.
System.AppDomain	Represents an application domain, which is a software-isolated environment in which applications execute. Application domains can hold code generated at runtime and can be unloaded.

## Further Libraries for Reflective Techniques

As discussed in Chapter 17, .NET and F# programming frequently use reflective techniques to analyze the types of objects, create objects at runtime, and use type information to drive generic functions in general ways. For example, in Chapter 17, you saw an example of a technique called *schema compilation*, which was based on .NET attributes, F# data types, and a compiler to take these and use reflective techniques to generate an efficient text-file reader and translator. The combination of reflective techniques and .NET generics allows programs to operate at the boundary between statically typed code and dynamically typed data.

## Using General Types

There are a number of facets to reflective programming with .NET. In one simple kind of reflective programming, a range of data structures are accessed in a general way. For example, .NET includes a type `System.Array` that is a parent type of all array types. The existence of this type allows you to write code that is generic over *all* array types, even one-dimensional and multidimensional arrays. This is occasionally useful, such as when you're writing a generic array printer.

Table 18-9 summarizes the primary general types defined in the .NET Framework.

**Table 18-9.** General types in the .NET Framework

Function	Description
System.Array	General type of all array values.
System.Delegate	General type of all delegates.
System.Enum	General type of all enum values.
System.Exception	General type of all exception values.
System.Collections.IEnumerable	General type of all sequence values. This is the nongeneric version of the F# type <code>seq&lt;'T&gt;</code> , and all sequence and collection values are compatible with this type.
System.IComparable	General type of all comparable types.

Function	Description
System.IDisposable	General type of all explicitly reclaimable resources.
System.IFormattable	General type of all types supporting .NET formatting.
System.Object	General type of all values.
System.Type	Runtime representation of .NET types.
System.ValueType	General type of all value types.

## Using Microsoft.FSharp.Reflection

In Chapter 17, the schema compiler used functions from the `Microsoft.FSharp.Reflection` namespace. This namespace is a relatively thin extension of the `System.Reflection` namespace. It offers an interesting set of techniques for creating and analyzing F# values and types in ways that are somewhat simpler than those offered by the `System.Reflection` namespace. These operations are also designed to be used in precompilation phases to amortize costs associated with reflective programming.

Table 18-10 summarizes the two types in this namespace

*Table 18-10. Some operations in the Microsoft.FSharp.Reflection namespace*

Class and Static Members	Description
Microsoft.FSharp.Reflection.FSharpType	Operations to analyze F# types
Microsoft.FSharp.Reflection.FSharpValue	Operations to analyze F# values

## Some Other .NET Types You May Encounter

When .NET was first designed, the .NET type system didn't include generics or a general notion of a function type as used by F#. Instead of functions, .NET uses delegates, which you can think of as named function types (that is, each kind of function type is given a different name).

This means that you often encounter delegate types when using .NET libraries from F#. Since .NET 2.0, some of these are even generic, giving an approximation of the simple and unified view of function types used by F#. Every .NET delegate type has a corresponding F# function type. For example, the F# function type for the .NET delegate type `System.Windows.Forms.PaintEventHandler` is `obj -> System.Windows.Forms.PaintEventArgs -> unit`. You can figure out this type by looking at the signature for the `Invoke` method of the given delegate type.

.NET also comes with definitions for some generic delegate types. F# tends to use function types instead of these, so you don't see them often in your coding. However, Table 18-11 shows these delegate types just in case you meet them.

*Table 18-11. Delegate types encountered occasionally in F# coding*

Function	F# Function Type	Description
System.Action<'T>	'T -> unit	Used for imperative actions.
System.AsyncCallback	System.IAsyncResult -> unit	Used for callbacks when asynchronous actions complete.
System.Converter<'T,'U>	'T -> 'U	Used to convert between values.
System.Comparison<'T>	'T -> 'T -> int	Used to compare values.

Function	F# Function Type	Description
<code>System.EventHandler&lt;'T&gt;</code>	<code>obj -&gt; 'T -&gt; unit</code>	Used as a generic event-handler type.
<code>System.Func&lt;'T, 'U&gt;</code>	<code>'T -&gt; 'U</code>	A .NET 3.5 LINQ function delegate. Further arity-overloaded types exist accepting additional arguments: for example, <code>System.Func&lt;'T, 'U, 'V&gt;</code> , <code>System.Func&lt;'T, 'U, 'V, 'W&gt;</code> .
<code>System.Predicate&lt;'T&gt;</code>	<code>'T -&gt; bool</code>	Used to test a condition.

## Under the Hood: Interoperating with C# and other .NET Languages

Libraries and binary components provide a common way to reuse software; even the simplest C program is linked to the standard C runtime to benefit from core functions, such as memory management and I/O. Modern programs depend on a large number of libraries that are shipped in binary form, and only some of them are written in the same language as the program. Libraries can be linked statically during compilation into the executable, or they can be loaded dynamically during program execution. Dynamic linking has become significantly common to help share code (dynamic libraries can be linked by different programs and shared among them) and adapt program behavior while executing.

Interoperability among binaries compiled by different compilers, even of the same language, can be a nightmare. One of the goals of the .NET initiative was to ease this issue by introducing the Common Language Runtime (CLR), which is targeted by different compilers and different languages to help interoperability among software developed in those languages.

### The Common Language Runtime

The CLR is a runtime designed to run programs compiled for the .NET platform; in addition to Microsoft, NET, CLR has been implemented by the open source project Mono. The binary format of these programs differs from the traditional one adopted by executables; Microsoft terminology uses *managed* for the first class of programs and *unmanaged* otherwise (see Figure 18-1).

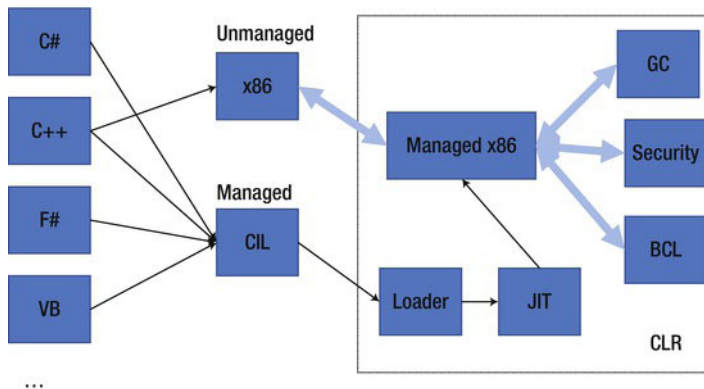

Figure 18-1. Compilation scheme for managed and unmanaged code

---

## A DEEPER LOOK INSIDE .NET EXECUTABLES

---

Programs for the .NET platform are distributed in a form that is executed by the CLR. Binaries are expressed in an intermediate language that is compiled incrementally by the Just-In-Time (JIT) compiler during program execution. A .NET assembly, in the form of a .dll or an .exe file, contains the definition of a set of types and the definition of the method bodies, and the additional data describing the structure of the code in the intermediate language form are known as *metadata*. The intermediate language is used to define method bodies based on a stack-based machine, with operations performed by loading values on a stack of operands and then invoking methods or operators.

Consider the following simple F# program in the `Program.fs` source file:

```
open System

let i = 2g

Console.WriteLine("Input a number:")

let v = Int32.Parse(Console.ReadLine())

Console.WriteLine(i * v)
```

The F# compiler generates an executable that can be disassembled using the `ildasm.exe` tool distributed with the .NET Framework. The following screenshot shows the structure of the generated assembly. Because everything in the CLR is defined in terms of types, the F# compiler must introduce the class `$Program$Main` in the `<StartupCode$applicationname>` namespace. In this class, the definition of the `main@` static method is the entry point for the execution of the program. This method contains the intermediate language corresponding to the example F# program. The F# compiler generates several elements that aren't defined in the program, whose goal is to preserve the semantics of the F# program in the intermediate language.

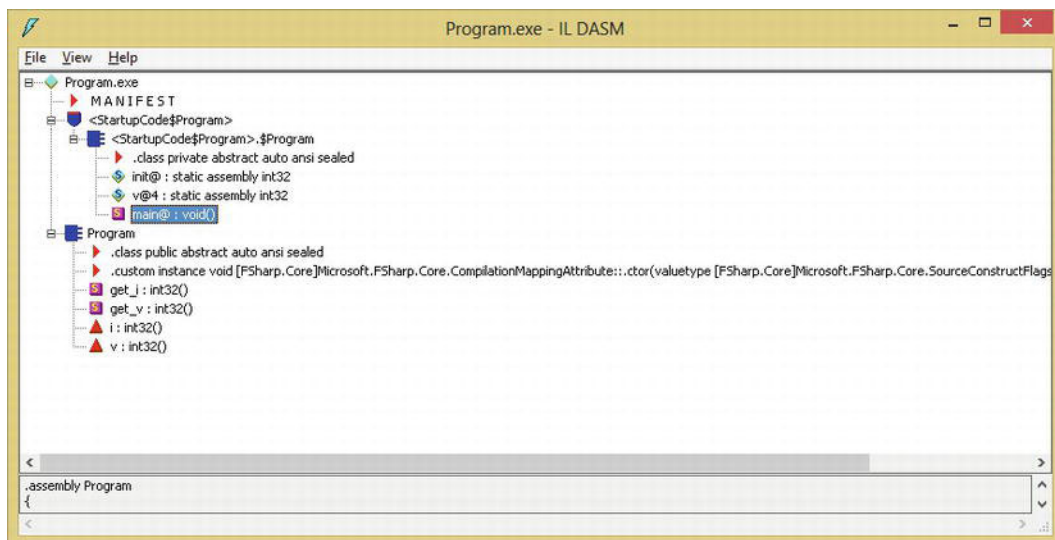

If you open the `main@` method, you find the following code, which is annotated here with the corresponding F# statements:



```

.method public static void main@() cil managed
{
    .entrypoint
    // Code size      38 (0x26)
    .maxstack 4

    // Console.WriteLine("Input a number:")
    IL_0000: ldstr      "Input a number:"
    IL_0005: call       void [mscorlib]System.Console::WriteLine(string)

    // let v = Int32.Parse(Console.ReadLine())
    IL_000a: call      string [mscorlib]System.Console::ReadLine()
    IL_000f: call      int32 [mscorlib]System.Int32::Parse(string)
    IL_0014: stsfld   int32 '<StartupCode$ConsoleApplication1>'. $Program::v@4

    // Console.WriteLine(i * v) // Note that i is constant and its value has been inlined
    IL_0019: ldc.i4.2
    IL_001a: call      int32 Program::get_v()
    IL_001f: mul
    IL_0020: call      void [mscorlib]System.Console::WriteLine(int32)

    // Exits
    IL_0025: ret
} // end of method $Program$Main::main@

```

The `ldxxx` instructions are used to load values onto the operand stack of the abstract machine, and the `stxxx` instructions store values from that stack in locations (locals, arguments, or class fields). In this example, a static field is used for `v`, and the value of `i` is inlined using the `ldc` instruction. For method invocations, arguments are loaded on the stack, and a `call` operation is used to invoke the method.

The JIT compiler is responsible for generating the binary code that runs on the actual processor. The code generated by the JIT interacts with all the elements of the runtime, including external code loaded dynamically in the form of DLLs or COM components.

Because the F# compiler targets the CLR, its output is managed code, allowing compiled programs to interact directly with other programming languages targeting the .NET platform. Chapter 16 showed how to exploit this form of interoperability, demonstrating how to develop a graphic control in F# and use it in a C# application.

## Memory Management at Runtime

Interoperability of F# programs with unmanaged code requires an understanding of the structure of the most important elements of a programming language's runtime. In particular, consider how program memory is organized at runtime. Memory used by a program is generally classified in three classes depending on the way it's handled:

- *Static memory*: Allocated for the entire lifetime of the program
- *Automatic memory*: Allocated and freed automatically when functions or methods are executed

- *Dynamic memory*: Explicitly allocated by the program, and freed explicitly or by an automatic program called the *garbage collector*

As a rule of thumb, top-level variables and static fields belong to the first class, function arguments and local variables belong to the second class, and memory explicitly allocated using the `new` operator belongs to the last class. The code generated by the JIT compiler uses different data structures to manage memory and automatically interacts with the operating system to request and release memory during program execution.

Each execution thread has a stack where local variables and arguments are allocated when a function or method is invoked (see Figure 18-2). A stack is used, because it naturally follows the execution flow of method and function calls. The topmost record contains data about the currently executing function; below that is the record of the caller of the function, which sits on top of another record of its caller, and so on. These *activation records* are memory blocks used to hold the memory required during the execution of the function and are naturally freed at the end of its execution by popping the record off the stack. The stack data structure is used to implement the automatic memory of the program, and because different threads execute different functions at the same time, a separate stack is assigned to each of them.

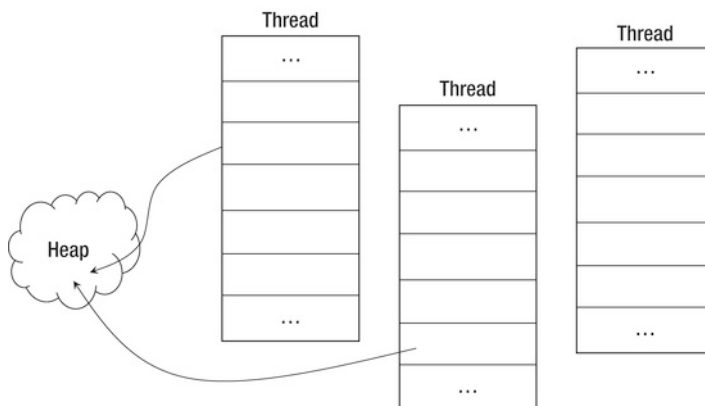

**Figure 18-2.** Memory organization of a running CLR program

Dynamic memory is allocated in the *heap*, which is a data structure where data resides for an amount of time not directly related to the events of program execution. The memory is explicitly allocated by the program, and it's deallocated either explicitly or automatically, depending on the strategy adopted by the runtime to manage the heap. In the CLR, the heap is managed by a *garbage collector*, which is a program that tracks memory usage and reclaims memory that is no longer used by the program. Data in the heap is always referenced from the stack—or other known areas, such as static memory—either directly or indirectly. The garbage collector can deduce the memory potentially reachable by program execution in the future, and the remaining memory can be collected. During garbage collection, the running program may be suspended, because the collector may need to manipulate objects needed by its execution. In particular, a garbage collector may adopt a strategy called *copy collection* that can move objects in memory; during this process, the references may be inconsistent. To avoid dangling references, the memory model adopted by the CLR requires that methods access the heap through object references stored on the stack; objects in the heap are forbidden to reference data on the stack.

Data structures are the essential tool provided by programming languages to group values. A data structure is rendered as a contiguous area of memory in which the constituents are available at a given offset from the beginning of the memory. The actual layout of an object is determined by the compiler (or by the interpreter for interpreted languages) and is usually irrelevant to the program because the programming

language provides operators to access fields without having to explicitly access the memory. System programming, however, often requires explicit manipulation of memory, and programming languages such as C let you control the in-memory layout of data structures. The C specification, for instance, defines that fields of a structure are laid out sequentially, although the compiler is allowed to insert extra space between them. Padding is used to align fields at word boundaries of the particular architecture in order to optimize the access to the fields of the structure. Thus, the same data structure in a program may lead to different memory layouts depending on the strategy of the compiler or the runtime, even in a language such as C, in which field ordering is well defined. By default, the CLR lays out structures in memory without any constraint, which gives you the freedom of optimizing memory usage on a particular architecture, although it may introduce interoperability issues if a portion of memory must be shared among the runtimes of different languages.<sup>1</sup>

Interoperability among different programming languages revolves mostly around memory layouts, because the execution of a compiled routine is a jump to a memory address. But routines access memory explicitly, expecting that data are organized in a certain way. The rest of this chapter discusses the mechanisms used by the CLR to interoperate with external code in the form of DLLs or COM components.

## COM Interoperability

Component Object Model (COM) is a technology that Microsoft introduced in the 1990s to support interoperability among different programs that were possibly developed by different vendors. The Object Linking and Embedding (OLE) technology that lets you embed arbitrary content in a Microsoft Word document, for instance, relies on this infrastructure. COM is a binary standard that allows code written in different languages to interoperate, assuming that the programming language supports this infrastructure. Most of the Windows operating system and its applications are based on COM components.

The CLR was initially conceived of as an essential tool to develop COM components, because COM was the key technology at the end of 1990s. It's no surprise that the Microsoft implementation of CLR interoperates easily and efficiently with the COM infrastructure.

This section briefly reviews how COM components can be consumed from F# (and vice versa) and how F# components can be exposed as COM components.

## Calling COM Components from F#

COM components can be easily consumed from F# programs, and the opposite is also possible, by exposing .NET objects as COM components. The following example is based on the Windows Scripting Host and uses F# and `fsi.exe`:

---

```
> open System;;
> let o = Activator.CreateInstance(Type.GetTypeFromProgID("Word.Application"));
val o : obj

> let t = o.GetType();
val t : Type = Microsoft.Office.Interop.Word.ApplicationClass

> t.GetProperty("Visible").SetValue(o, (true :> Object), null);
val it : unit = ()
```

<sup>1</sup>Languages targeting .NET aren't affected by these interoperability issues because they share the same CLR runtime.

```

> let m = t.GetMethod("Quit");;
val m : Reflection.MethodInfo =
    Void Quit(System.Object ByRef, System.Object ByRef, System.Object ByRef)

> m.GetParameters().Length;;
val it : int = 3

> m.GetParameters();;
val it : Reflection.ParameterInfo [] =
    [|System.Object& SaveChanges
      {Attributes = In, Optional, HasFieldMarshal;
        CustomAttributes = seq
          [[System.Runtime.InteropServices.InAttribute();
            [System.Runtime.InteropServices.OptionalAttribute());
            [System.Runtime.InteropServices.MarshalAsAttribute((System.
Runtime.InteropServices.UnmanagedType)27, ArraySubType = 0, SizeParamIndex = 0, SizeConst = 0,
IidParameterIndex = 0, SafeArraySubType = 0)]];
        DefaultValue = System.Reflection.Missing;
        HasDefaultValue = false;
        IsIn = true;
        IsLcid = false;
        IsOptional = true;
        IsOut = false;
        IsRetVal = false;
        Member = Void Quit(System.Object ByRef, System.Object ByRef, System.Object ByRef);
        MetadataToken = 134223584;
        Name = "SaveChanges";
        ParameterType = System.Object&;
        Position = 0;
        RawDefaultValue = System.Reflection.Missing;};
    ... more ... |]

> m.Invoke(o, [|null; null; null|]);;

```

---

*val it : obj = null* Because F# imposes type inference, you can't use the simple syntax provided by an interpreter. The compiler should know in advance the number and type of arguments of a method and the methods exposed by an object. Remember that even though `fsi.exe` allows you to interactively execute F# statements, it's still subject to the constraints of a compiled language. Because you're creating an instance of a COM component dynamically in this example, the compiler doesn't know anything about this component, so it can be typed as `System.Object`. To obtain the same behavior as an interpreted language, you must resort to .NET runtime's reflection support. Using the `GetMethod` method, you can obtain an object describing the type of the object `o`. Then, you can obtain a `PropertyInfo` object describing the `Visible` property, and you can invoke the `SetValue` method on it to show the Word main window. The `SetValue` method is generic; therefore, you have to cast the Boolean value to `System.Object` to comply with the method signature.

In a similar way, you can obtain an instance of the `MethodInfo` class describing the `Quit` method. Because a method has a signature, you ask for the parameters; there are three of them, and they're optional. You can invoke the `Quit` method by calling the `Invoke` method and passing the object target of the invocation and an array of arguments that you set to `null`, because arguments are optional.

■ **Note:** Although COM technology is still widely used for obtaining so-called automation, .NET is quietly entering the picture, and several COM components are implemented using the CLR. Whenever a reference to `mscorlib.dll` appears in the `InprocServer32` registry key, the .NET runtime is used to deliver the COM services using the specified assembly. Through COM interfaces, native and .NET components can be composed seamlessly, leading to very complex interactions between managed and unmanaged worlds. Microsoft Word 2010, for instance, returns a .NET object instead of a COM wrapper, which provides access to Word services without the need for explicit use of reflection.

How can the runtime interact with COM components? The basic approach is based on the *COM callable wrapper* (CCW) and the *runtime callable wrapper* (RCW), as shown in Figure 18-3. The former is a chunk of memory dynamically generated with a layout compatible with the one expected from COM components, so that external programs—even legacy Visual Basic 6 applications—can access services implemented as managed components. The latter is more common and creates a .NET type dealing with the COM component, taking care of all the interoperability issues. It's worth noting that although the CCW can always be generated, because the .NET runtime has full knowledge about assemblies, the opposite isn't always possible. Without `IDispatch` or type libraries, there is no description of a COM component at runtime. Moreover, if a component uses custom marshalling, it can't be wrapped by an RCW. Fortunately, for the majority of COM components, it's possible to generate an RCW.

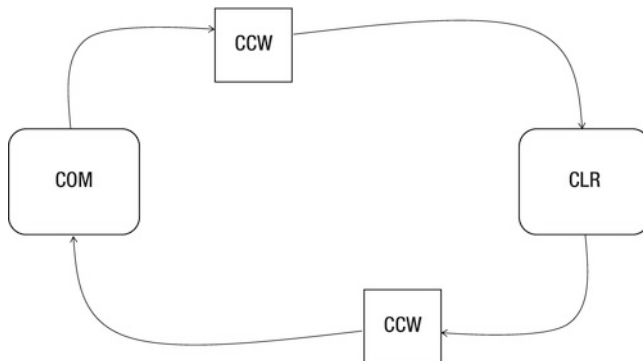

Figure 18-3. The wrappers generated by the CLR to interact with COM components

Programming patterns based on event-driven programming are widely adopted, and COM components have a programming pattern to implement callbacks based on the notion of a *sink*. The programming pattern is based on the delegate event model, and the sink is where a listener can register a COM interface that should be invoked by a component to notify an event. The Internet Explorer Web Browser COM component (implemented by `shdocvw.dll`), for instance, provides a number of events to notify its host about various events, such as loading a page or clicking a hyperlink. The RCW generated by the runtime exposes these events in the form of delegates and takes care of handling all the details required to perform the communication between managed and unmanaged code.

Although COM components can be accessed dynamically using .NET reflection, explicitly relying on the ability of the CLR to generate CCW and RCW, it's desirable to use a less verbose approach to COM interoperability. The .NET runtime ships with tools that allow you to generate RCW and CCW wrappers offline, which lets you use COM components as .NET classes and vice versa. These tools are:

- `tlbimp.exe`: This is a tool for generating an RCW of a COM component given its type library.
- `aximp.exe`: This is similar to `tlbimp.exe` and supports the generation of “ActiveX” COM components<sup>2</sup> that have graphical interfaces and that can be integrated with Windows Forms.
- `tlbexp.exe`: This generates a COM type library describing a .NET assembly. The CLR is loaded as a COM component and generates the appropriate CCW to make .NET types accessible as COM components.
- `regasm.exe`: This is similar to `tlbexp.exe`. It also performs the registration of the assembly as a COM component.

To better understand how COM components can be accessed from your F# programs and vice versa, let's consider two examples. In the first, you wrap the widely used Flash Player into a form interactively; in the second, you see how an F# object type can be consumed as if it were a COM component.

The Flash Player you're accustomed to using in everyday browsing is a COM control that is loaded by Internet Explorer using an `OBJECT` element in the HTML page (it's also a plug-in for other browsers, but here you're interested in the COM component). By using a search engine, you can easily find that an HTML element similar to the following is used to embed the player in Internet Explorer:

```
<OBJECT
  classid="clsid:D27CDB6E-AE6D-11cf-96B8-444553540000"
  codebase="http://download.macromedia.com/pub/shockwave/cabs/flash/swflash.cab"
  title="My movie" width="640" height="480">
  <param name="movie" value="MyMovie.swf" />
  <param name="quality" value="high" />
</OBJECT>
```

From this tag, you know that the CLSID of the Flash Player COM component is the one specified with the `classid` attribute of the `OBJECT` element. You can now look in the Windows registry under `HKEY_CLASSES_ROOT\CLSID` for the subkey corresponding to the CLSID of the Flash COM control. If you look at the subkeys, you notice that the ProgID of the component is `ShockwaveFlash.ShockwaveFlash`, and `InprocServer32` indicates that its location is `C:\Windows\system32\Macromed\Flash\FFlash10d.ocx`. You can also find the GUID relative to the component type library—which, when investigated, shows that the type library is contained in the same OCX file.

---

■ **Note:** With a 64-bit version of Windows and the 32-bit version of the Flash Player, you should look for the key CLSID under `HKEY_CLASSES_ROOT\Wow6432Node`, which is where the 32-bit component's information is stored. In general, all references to the 32-bit code are stored separately from the 64-bit information. The loader tricks old 32-bit code into seeing different portions of the registry. In addition, executable files are stored under `%WinDir%\SysWow64` instead of `%WinDir%\system32`. Moreover, to wrap 32- or 64-bit components, you need the corresponding version of the .NET tool.

---

<sup>2</sup>ActiveX components are COM components implementing a well-defined set of interfaces. They have a graphical interface. Internet Explorer is well known for loading these components, but ActiveX can be loaded by any application using the COM infrastructure.

Because Flash Player is a COM control with a GUI, you can rely on `aximp.exe` rather than just `tlbimp.exe` to generate the RCW for the COM component (for 64-bit systems, use `c:\Windows\SysWOW64` instead of `c:\Windows\System32` and link the `.ocx` file contained in the Flash directory):

---

```
C:\> aximp c:\Windows\System32\Macromed\F\Flash\F\Flash32_11_3_370_17810d.ocx
Generated Assembly: C:\ShockwaveFlashObjects.dll
Generated Assembly: C:\AxShockwaveFlashObjects.dll
```

---

If you use `ildasm.exe` to analyze the structure of the generated assemblies, notice that the wrapper of the COM component is contained in `ShockwaveFlashObjects.dll` and is generated by the `tlbimp.exe` tool. The second assembly contains a Windows Forms host for COM components and is configured to host the COM component, exposing the GUI features in terms of the elements of the Windows Forms framework.

You can test the Flash Player embedded in an interactive F# session:

---

```
#I @"c:\";;
--> Added 'c:\ ' to library include path

#r "AxShockwaveFlashObjects.dll";;
--> Referenced 'c:\AxShockwaveFlashObjects.dll'

> open AxShockwaveFlashObjects;;
> open System.Windows.Forms;;

> let f = new Form();;
val f : Form = System.Windows.Forms.Form, Text:

> let flash = new AxShockwaveFlash();;
val flash : AxShockwaveFlash = AxShockwaveFlashObjects.AxShockwaveFlash

> f.Show();;
> flash.Dock <- DockStyle.Fill;;
> f.Controls.Add(flash);;
> flash.LoadMovie(0, "http://laptop.org/img/meshDemo18.swf");;
```

---

First add to the include path of the `fsi.exe` directory containing the assemblies generated by `aximp.exe` using the `#I` directive, and then reference the `AxShockwaveFlashObjects.dll` assembly using the `#r` directive. The namespace `AxShockwaveFlashObjects` containing the `AxShockwaveFlash` class is opened; this is the managed class wrapping the COM control. You create an instance of the Flash Player that is now exposed as a Windows Forms control; then set the `Dock` property to `DockStyle.Fill` to let the control occupy the entire area of the form. Finally, add the control to the form.

When you're typing the commands into F# Interactive, it's possible to test the content of the form. When it first appears, a right-click on the client area is ignored. After the COM control is added to the form, the right-click displays the context menu of the Flash Player. You can now programmatically control the player by setting the properties and invoking its methods; the generated wrapper takes care of all the communications with the COM component.

## The Running Object Table

Sometimes you need to obtain a reference to an out-of-process COM object that is already running. This is useful when you want to automate some task of an already-started application or reuse an object model without needing to start a process more than once. The easiest way to achieve this is through the `GetActiveObject` method featured by the `Marshal` class:

```
#r "EnvDTE80"
open System.Runtime.InteropServices

let appObj = Marshal.GetActiveObject("VisualStudio.DTE.11.0") :?> EnvDTE80.DTE2
printfn "%s" appObj.ActiveDocument.FullName.
```

In this example, you obtain a reference to one of the most important interfaces of Visual Studio's COM automation model. An interesting experiment is printing the name of the active document open in the editor and trying to run different instances of Visual Studio, opening different documents. The COM infrastructure connects to one instance of the COM server without being able to specify a particular one.

You can find a specific instance by accessing a system-wide data structure called the Running Object Table (ROT), which provides a list of running COM servers. Because the name of a running server must be unique within the ROT, many servers mangle the PID with the COM ProgID, so it's possible to connect to a given instance. This is the case for Visual Studio. The following F# function connects to a specific Visual Studio instance:

```
#r "EnvDTE"

open System.Runtime.InteropServices
open System.Runtime.InteropServices.ComTypes

[<DllImport("ole32.dll")>]
extern int internal GetRunningObjectTable(uint32 reserved, IRunningObjectTable& pprot)

[<DllImport("ole32.dll")>]
extern int internal CreateBindCtx(uint32 reserved, IBindCtx& pctx)

let FetchVSDTE (pid : int) =
    let mutable prot : IRunningObjectTable = null
    let mutable pmonkenum : IEnumMoniker = null
    let (monikers : IMoniker[]) = Array.create 1 null
    let pfetched = System.IntPtr.Zero
    let mutable (ret : obj) = null
    let endpid = sprintf "%d" pid

    try
        if (GetRunningObjectTable(0u, &prot) <> 0) || (prot = null) then
            failwith "Error opening the ROT"
        prot.EnumRunning(&pmonkenum)
        pmonkenum.Reset()
        while pmonkenum.Next(1, monikers, pfetched) = 0 do
            let mutable (insname : string) = null
            let mutable (pctx : IBindCtx) = null
            CreateBindCtx(0u, &pctx) |> ignore
            (monikers.[0]).GetDisplayName(pctx, null, &insname);
```



```

    Marshal.ReleaseComObject(pctx) |> ignore
    if insname.StartsWith("!VisualStudio.DTE") && insname.EndsWith(endpid) then
        prot.GetObject(monikers.[0], &ret) |> ignore
finally
    if prot <> null then Marshal.ReleaseComObject(prot) |> ignore
    if pmonkenum <> null then Marshal.ReleaseComObject(pmonkenum) |> ignore
(ret :?)> EnvDTE.DTE)

```

You use two `PInvoke` declarations to import functions from the `ole.dll` COM library in which the ROT is defined. After you get a reference to the table, you perform an enumeration of its elements, retrieving the display name and looking for any Visual Studio DTE with a specific PID at its end. The `GetObject` method is used to finally connect to the desired interface.

This example shows the flexible control .NET and F# can provide over COM infrastructure. The ability to access specific COM object instances is widely used on the server side to implement services made available through Web pages.

## Interoperating with C and C++ with PInvoke

Through the CLI, F# implements a standard mechanism for interoperating with C and C++ code that is called “Platform Invoke”, normally known as “PInvoke”. This is a core feature of the standard available on all CLI implementations, including Mono.

The basic model underlying PInvoke is based on loading DLLs into the program, which allows managed code to invoke functions exported from C and C++. DLLs don’t provide information other than the entry point location of a function; this isn’t enough to perform the invocation unless additional information is made available to the runtime.

The invocation of a function requires:

- The address of the code in memory
- The calling convention, which is how parameters, return values, and other information are passed through the stack to the function
- Marshalling of values and pointers so that the different runtime support can operate consistently on the same values

You obtain the address of the entry point using a system call that returns the pointer to the function given a string. You must provide the remaining information to instruct the CLR about how the function pointer should be used.

---

### CALLING CONVENTIONS

---

Function and method calls (a method call is similar to a function call but with an additional pointer referring to the object passed to the method) are performed by using a shared stack between the caller and the callee. An activation record is pushed onto the stack when the function is called, and memory is allocated for arguments, the return value, and local variables. Additional information—such as information about exception handling and the return address when the execution of the function terminates—is also stored in the activation record,

The physical structure of the activation record is established by the compiler (or by the JIT in the case of the CLR), and this knowledge must be shared between the caller and the called function. When the binary code

is generated by a compiler, this isn't an issue, but when code generated by different compilers must interact, it may become a significant issue. Although each compiler may adopt a different convention, the need to perform system calls requires that the calling convention adopted by the operating system is implemented, and it's often used to interact with different runtimes. Another popular approach is to support the calling convention adopted by C compilers, because it's widely used and has become a fairly universal language for interoperability. Note that although many operating systems are implemented in C, the libraries providing system calls may adopt different calling conventions. This is the case with Microsoft Windows: the operating system adopts the *stdcall* calling convention rather than *cdecl*, which is the C calling convention.

A significant dimension in the arena of possible calling conventions is the responsibility for removing the activation record from the thread stack. At first glance, it may seem obvious that before returning, the called function resets the stack pointer to the previous state. This isn't the case for programming languages such as C that allow functions with a variable number of arguments, such as `printf`. When variable arguments are allowed, the caller knows the exact size of the activation record; therefore, it's the caller's responsibility to free the stack at the end of the function call. Apart from being consistent with the chosen convention, there may seem to be little difference between the two choices, but if the caller is responsible for cleaning the stack, each function invocation requires more instructions, which leads to larger executables. For this reason, Windows uses the *stdcall* calling convention instead of the C calling convention. It's important to notice that the CLR uses an array of objects to pass a variable number of arguments, which is very different from the variable arguments of C: the method receives a single pointer to the array that resides in the heap.

It's important to note that if the memory layout of the activation record is compatible, as it is in Windows, using the *cdecl* convention instead of the *stdcall* convention leads to a subtle memory leak. If the runtime assumes the *stdcall* convention (which is the default), and the callee assumes the *cdecl* convention, the arguments pushed on the stack aren't freed, and at each invocation, the height of the stack grows until a stack overflow happens.

The CLR supports a number of calling conventions. The two most important are *stdcall* and *cdecl*. Other implementations of the runtime may provide additional conventions to the user. In the PInvoke design, nothing restricts the supported conventions to these two (and in fact the runtime uses the *fastcall* convention to invoke services provided by the runtime from managed code).

The additional information required to perform the function call is provided by custom attributes that are used to decorate a function prototype and inform the runtime about the signature of the exported function.

## Getting Started with PInvoke

This section starts with a simple example of a DLL developed using C++, to which you add code during your experiments using PInvoke. The `CInteropDLL.h` header file declares a macro defining the decorations associated with each exported function:

```
#define CINTEROPDLL_API __declspec(dllexport)
extern "C" {
void CINTEROPDLL_API HelloWorld();
}
```

The `__declspec` directive is specific to the Microsoft Visual C++ compiler. Other compilers may provide different ways to indicate the functions that must be exported when compiling a DLL.

The first function is `HelloWorld`; its definition is as expected:

```
void CINTEROPDLL_API HelloWorld()
{
    printf("Hello C world invoked by F#!\n");
}
```

Say you now want to invoke the `HelloWorld` function from an F# program. You have to define the prototype of the function and inform the runtime how to access the DLL and the other information needed to perform the invocation. The program performing the invocation is:

```
open System.Runtime.InteropServices

module CInterop =
    [DllImport("CInteropDLL", CallingConvention = CallingConvention.Cdecl)]
    extern void HelloWorld()

CInterop.HelloWorld()
```

The `extern` keyword informs the compiler that the function definition is external to the program and must be accessed through the `PInvoke` interface. A C-style prototype definition follows the keyword, and the whole declaration is annotated with a custom attribute defined in the `System.Runtime.InteropServices` namespace. The F# compiler adopts C-style syntax for extern prototypes, including argument types (as you see later), because C headers and prototypes are widely used; this choice helps in the `PInvoke` definition. The `DllImport` custom attribute provides the information needed to perform the invocation. The first argument is the name of the DLL containing the function; the remaining option specifies the calling convention chosen to make the call. Because you don't specify otherwise, the runtime assumes that the name of the F# function is the same as the name of the entry point in the DLL. You can override this behavior using the `EntryPoint` parameter in the `DllImport` attribute.

It's important to note the declarative approach of the `PInvoke` interface. No code is involved in accessing external functions. The runtime interprets metadata in order to automatically interoperate with native code contained in a DLL. This is a different approach from the one adopted by different virtual machines, such as the Java virtual machine. The Java Native Interface (JNI) requires that you define a layer of code using types of the virtual machine and invoke the native code.

`PInvoke` requires high privileges in order to execute native code, because the activation record of the native function is allocated on the same stack that contains the activation records of managed functions and methods. Moreover, as discussed shortly, it's also possible to have the native code invoking a delegate marshalled as a function pointer, allowing stacks with native and managed activation records to be interleaved.

The `HelloWorld` function is a simple case, because the function doesn't have input arguments and doesn't return any value. Consider this function with input arguments and a return value:

```
int CINTEROPDLL_API Sum(int i, int j)
{
    return i + j;
}
```

Invoking the `Sum` function requires integer values to be marshalled to the native code and the value returned to managed code. Simple types, such as integers, are easy to marshal, because they're usually passed by value and use types of the underlying architecture. The F# program using the `Sum` function is:

```
module CInterop =
    [DllImport("CInteropDLL", CallingConvention = CallingConvention.Cdecl)]
    extern int Sum(int i, int j)

printf "Sum(1, 1) = %d\n" (CInterop.Sum(1, 1));
```

Parameter passing assumes the same semantics of the CLR, and parameters are passed by value for value types and by the value of the reference for reference types. Again, you use the custom attribute to specify the calling convention for the invocation.

## Mapping C Data Structures to F# Code

Let's first cover what happens when structured data are marshalled by the CLR in the case of nontrivial argument types. Here, you see the `SumC` function responsible for adding two complex numbers defined by the `Complex` C data structure:

```
typedef struct _Complex {
    double re;
    double im;
} Complex;

Complex CINTEROPDLL_API SumC(Complex c1, Complex c2)
{
    Complex ret;
    ret.re = c1.re + c2.re;
    ret.im = c1.im + c2.im;
    return ret;
}
```

To invoke this function from F#, you must define a data structure in F# corresponding to the `Complex` C structure. If the memory layout of an instance of the F# structure is the same as that of the corresponding C structure, values can be shared between the two languages. How can you control the memory layout of a managed data structure? Fortunately, the `PInvoke` specification helps with custom attributes that let you specify the memory layout of data structures. The `StructLayout` custom attribute indicates the strategy adopted by the runtime to lay out fields of the data structure. By default, the runtime adopts its own strategy in an attempt to optimize the size of the structure, keeping fields aligned to the machine world in order to ensure fast access to the structure's fields. The C standard ensures that fields are laid out in memory sequentially in the order they appear in the structure definition; other languages may use different strategies. Using an appropriate argument, you can indicate that a C-like sequential layout strategy should be adopted. It's also possible to provide an explicit layout for the structure, indicating the offset in memory for each field of the structure. This example uses the sequential layout for the `Complex` value type:

```
module CInterop =
    [

```

```
let mutable c3 = CInterop.SumC(c1, c2)
printf "c3 = SumC(c1, c2) = %f + %fi\n" c3.re c3.im
```

The `SumC` prototype refers to the F# `Complex` value type. But because the layout of the structure in memory is the same as the corresponding C structure, the runtime passes the bits that are consistent with those expected by the C code.

## Marshalling Parameters to and from C

A critical aspect of dealing with `PInvoke` is ensuring that values are marshalled correctly between managed and native code, and vice versa. A structure's memory layout doesn't depend only on the order of the fields. Compilers often introduce padding to align fields to memory addresses so that access to fields requires fewer memory operations, because CPUs load data into registers with the same strategy. Padding may speed up access to the data structure, but it introduces inefficiencies in memory usage: there may be gaps in the structures, leading to allocated but unused memory.

Consider, for instance, the C structure:

```
struct Foo {
    int i;
    char c;
    short s;
};
```

Depending on the compiler decision, it may occupy from 8 to 12 bytes on a 32-bit architecture. The most compact version of the structure uses the first 4 bytes for `i`, a single byte for `c`, and 2 more bytes for `s`. If the compiler aligns fields to addresses that are multiples of 4, then the integer `i` occupies the first slot, 4 more bytes are allocated for `c` (although only one is used), and the same happens for `s`.

Padding is a common practice in C programs; because it may affect performance and memory usage, directives instruct the compiler about padding. It's possible to have data structures with different padding strategies running within the same program.

The first step you face when using `PInvoke` to access native code is finding the definition of data structures, including information about padding. Then, you can annotate F# structures to have the same layout as the native ones, and the CLR can automate the marshalling of data. You can pass parameters by reference; thus, the C code may access the memory managed by the runtime, and errors in memory layout may result in corrupted memory. For this reason, keep `PInvoke` code to a minimum and verify it accurately to ensure that the execution state of the virtual machine is preserved. The declarative nature of the interface is a great help in this respect, because you must check declarations and not interop code.

Not all the values are marshalled as is to native code; some may require additional work from the runtime. Strings, for instance, have different memory representations between native and managed code. C strings are arrays of bytes that are null terminated, whereas runtime strings are .NET objects with a different layout. Also, function pointers are mediated by the runtime: the calling convention adopted by the CLR isn't compatible with external conventions, so code stubs are generated that can be called by native code from managed code, and vice versa.

In the `SumC` example, arguments are passed by value, but native code often requires data structures to be passed by reference to avoid the cost of copying the entire structure and passing only a pointer to the native data. The `ZeroC` function resets a complex number whose pointer is passed as an argument:

```
void CINTEROPDLL_API ZeroC(Complex* c)
{
    c->re = 0;
    c->im = 0;
}
```

The F# declaration for the function is the same as the C prototype:

```
[<DllImport("CInteropDLL", CallingConvention = CallingConvention.Cdecl)>]
extern void ZeroC(Complex* c)
```

Now you need a way to obtain a pointer given a value of type `Complex` in F#. You can use the `&&` operator to indicate a pass by reference; this results in passing the pointer to the structure expected by the C function:

```
let mutable c4 = CInterop.SumC(c1, c2)
printf "c4 = SumC(c1, c2) = %f + %fi\n" c4.re c4.im
```

```
CInterop.ZeroC(&&c4)
printf "c4 = %f + %fi\n" c4.re c4.im
```

In C and C++, the notion of objects (or struct instances) and the classes of memory are orthogonal: an object can be allocated on the stack or on the heap and share the same declaration. In .NET, this isn't the case; objects are instances of classes and are allocated on the heap, and value types are stored in the stack or wrapped into objects in the heap.

Can you pass objects to native functions through `PInvoke`? The main issue with objects is that the heap is managed by the garbage collector, and one possible strategy for garbage collection is *copy collection* (a technique that moves objects in the heap when a collection occurs). Thus, the base address in memory of an object may change over time, which can be a serious problem if the pointer to the object has been marshalled to a native function through a `PInvoke` invocation. The CLR provides an operation called *pinning* that prevents an object from moving during garbage collection. Pinned pointers are assigned to local variables, and pinning is released when the function performing the pinning exits. It's important to understand the scope of pinning: if the native code stores the pointer somewhere before returning, the pointer may become invalid but still usable from native code.

Now, let's define an object type for `Complex` and marshal F# objects to a C function. The goal is to marshal the F# object to the `ZeroC` function. In this case, you can't use the pass-by-reference operator, and you must define everything so that the type checker is happy. You can define another function that refers to `ZeroC` but with a different signature involving `ObjComplex`, which is an object type similar to the `Complex` value type. The `EntryPoint` parameter maps the F# function onto the same `ZeroC` C function, although in this case, the argument is of type `ObjComplex` rather than `Complex`:

```
module CInterop =
    [<StructLayout(LayoutKind.Sequential)>]
    type ObjComplex =
        val mutable re : double
        val mutable im : double

        new() = {re = 0.0; im = 0.0}
        new(r : double, i : double) = {re = r; im = i}

    [<DllImport("CInteropDLL", EntryPoint = "ZeroC",
        CallingConvention = CallingConvention.Cdecl)>]
    extern void ObjZeroC(ObjComplex c)

let oc = CInterop.ObjComplex(2.0, 1.0)
printf "oc = %f + %fi\n" oc.re oc.im
CInterop.ObjZeroC(oc)
printf "oc = %f + %fi\n" oc.re oc.im
```

In this case, the object reference is marshalled as a pointer to the C code, and you don't need the `&&` operator in order to call the function. The object is pinned to ensure that it doesn't move during the function call.

## Marshalling Strings to and from C

`PInvoke` defines the default behavior for mapping common types used by the Win32 API. Table 18-12 shows the default conversions. Most of the mappings are natural, but note that there are several entries for strings. This is because strings are represented in different ways in programming language runtimes.

*Table 18-12. Default mapping for types of the Win32 API listed in `Wtypes.h`*

Unmanaged Type in <code>Wtypes.h</code>	Unmanaged C Type	Managed Class	Description
HANDLE	<code>void*</code>	<code>System.IntPtr</code>	32 bits on 32-bit Windows operating systems, 64 bits on 64-bit Windows operating systems
BYTE	<code>unsigned char</code>	<code>System.Byte</code>	8 bits
SHORT	<code>short</code>	<code>System.Int16</code>	16 bits
WORD	<code>unsigned short</code>	<code>System.UInt16</code>	16 bits
INT	<code>int</code>	<code>System.Int32</code>	32 bits
UINT	<code>unsigned int</code>	<code>System.UInt32</code>	32 bits
LONG	<code>long</code>	<code>System.Int32</code>	32 bits
BOOL	<code>long</code>	<code>System.Int32</code>	32 bits
DWORD	<code>unsigned long</code>	<code>System.UInt32</code>	32 bits
ULONG	<code>unsigned long</code>	<code>System.UInt32</code>	32 bits
CHAR	<code>char</code>	<code>System.Char</code>	Decorate with ANSI
LPSTR	<code>char*</code>	<code>System.String</code> or <code>System.Text.StringBuilder</code>	Decorate with ANSI
LPCSTR	<code>const char*</code>	<code>System.String</code> or <code>System.Text.StringBuilder</code>	Decorate with ANSI
LPWSTR	<code>wchar_t*</code>	<code>System.String</code> or <code>System.Text.StringBuilder</code>	Decorate with Unicode
LPCWSTR	<code>const wchar_t*</code>	<code>System.String</code> or <code>System.Text.StringBuilder</code>	Decorate with Unicode
FLOAT	<code>Float</code>	<code>System.Single</code>	32 bits
DOUBLE	<code>Double</code>	<code>System.Double</code>	64 bits

To see how strings are marshalled, start with a simple C function that echoes a string on the console:

```
void CINTEROPDLL_API echo(char* str)
{
    puts(str);
}
```

The corresponding F# `PInvoke` prototype is:

```
[<DllImport("CInteropDLL", CallingConvention = CallingConvention.Cdecl)>]
extern void echo(string s)
```

What happens when the F# function `echo` is invoked? The managed string is represented by an array of Unicode characters described by an object in the heap; the C function expects a pointer to an array of single-byte ANSI characters that are null terminated. The runtime is responsible for performing the conversion between the two formats, and it's performed by default when mapping a .NET string to an ANSI C string.

It's common to pass strings that are modified by C functions, yet .NET strings are immutable. For this reason, it's also possible to use a `System.Text.StringBuilder` object instead of a string. Instances of this class represent mutable strings and have an associated buffer containing the characters of the string. You can write a C function in the DLL that fills a string buffer given the size of the buffer:

```
void CINTEROPDLL_API sayhello(char* str, int sz)
{
    static char* data = "Hello from C code!";
    int len = min(sz, strlen(data));
    strncpy(str, data, len);
    str[len] = 0;
}
```

Because the function writes into the string buffer passed as an argument, use a `StringBuilder` rather than a string to ensure that the buffer has the appropriate room for the function to write. You can use the F# `PInvoke` prototype:

```
open System.Text
[<DllImport("CInteropDLL", CallingConvention = CallingConvention.Cdecl)>]
extern void sayhello(StringBuilder sb, int sz)
```

Because you have to indicate the size of the buffer, you can use a constructor of the `StringBuilder` class that allows you to do so:

```
let sb = new StringBuilder(50)
sayhello(sb, 50)
printf "%s\n" (sb.ToString())
```

You've used ANSI C strings so far, but this isn't the only type of string. Wide-character strings are becoming widely adopted and use 2 bytes to represent a single character; following the C tradition, the string is terminated by a null character. Consider a wide-character version of the `sayhello` function:

```
void CINTEROPDLL_API sayhellow(wchar_t* str, int sz)
{
    static wchar_t* data = L"Hello from C code Wide!";
    int len = min(sz, wcslen(data));
    wcsncpy(str, data, len);
    str[len] = 0;
}
```

How can you instruct the runtime that the `StringBuilder` should be marshalled as a wide-character string rather than an ANSI string? The declarative nature of `PInvoke` helps by providing a custom attribute to annotate function parameters of the prototype and to inform the CLR about the marshalling strategy to be adopted. The `sayhello` function is declared in F# as:

```
open System.Text
[<DllImport("CInteropDLL", CallingConvention = CallingConvention.Cdecl)>]
```



```
extern void sayhello([<MarshalAs(UnmanagedType.LPWStr)>]StringBuilder sb, int sz)
```

In this case, the `MarshalAs` attribute indicates that the string should be marshalled as LPWSTR rather than LPSTR.

## Passing Function Pointers to C

Another important data type that often should be passed to native code is a function pointer. Function pointers, which are widely used to implement callbacks, provide a simple form of functional programming; think, for instance, of a sort function that receives as input the pointer to the comparison function. Graphical toolkits have widely used this data type to implement event-driven programming, and they often have to pass a function that is invoked by another one.

`PInvoke` can marshal delegates as function pointers; again, the runtime is responsible for generating a suitable function pointer callable from native code. When the marshalled function pointer is invoked, a stub is called, and the activation record on the stack is rearranged to be compatible with the calling convention of the runtime. Then, the delegate function is invoked.

Although in principle the generated stub is responsible for implementing the calling convention adopted by the native code receiving the function pointer, the CLR supports only the `stdcall` calling convention for marshalling function pointers. Thus, the native code should adopt this calling convention when invoking the pointer. This restriction may cause problems, but in general, on the Windows platform, the `stdcall` calling convention is widely used.

The following C function uses a function pointer to apply a function to an array of integers:

```
typedef int (_stdcall *TRANSFORM_CALLBACK)(int);

void CINTEROPDLL_API transformArray(int* data, int count, TRANSFORM_CALLBACK fn)
{
    int i;
    for (i = 0; i < count; i++)
        data[i] = fn(data[i]);
}
```

The `TRANSFORM_CALLBACK` type definition defines the prototype of the function pointer you're interested in here: a function takes an integer as the input argument and returns an integer as a result. The `CALLBACK` macro is specific to the Microsoft Visual C++ compiler and expands to `__stdcall` in order to indicate that the function pointer, when invoked, should adopt the `stdcall` calling convention instead of the `cdecl` calling convention.

The `transformArray` function takes as input an array of integers with its length and the function to apply to its elements. You now have to define the F# prototype for this function by introducing a delegate type with the same signature as `TRANSFORM_CALLBACK`:

```
type Callback = delegate of int -> int
```

```
[<DllImport("CInteropDLL", CallingConvention = CallingConvention.Cdecl)>]
extern void transformArray(int[] data, int count, Callback transform)
```

Now you can increment all the elements of an array by using the C function:

```
let anyToString any = sprintf "%A" any
let data = [|1; 2; 3|]
printf "%s\n" (String.Join("; ", (Array.map anyToString data)))
```

```
transformArray(data, data.Length, new Callback(fun x -> x + 1))
printf "%s\n" (String.Join("; ", (Array.map anyToString data)))
```

PInvoke declarations are concise, but for data types such as function pointers, parameter passing can be expensive. In general, libraries assume that crossing the language boundary causes a loss of efficiency and callbacks are invoked at a price different from ordinary functions. In this respect, the example represents a situation in which the overhead of PInvoke is significant: a single call to `transformArray` causes a number of callbacks without performing any real computation into the native code.

## PInvoke Memory Mapping

As a more complicated example of PInvoke usage, this section shows you how to benefit from memory mapping into F# programs. Memory mapping is a popular technique that allows a program to see a file (or a portion of a file) as if it were in memory. This provides an efficient way to access files, because the operating system uses the machinery of virtual memory to access files and significantly speed up data access on files. After proper initialization, which is covered in a moment, the program obtains a pointer into the memory, and access to that portion of memory appears the same as accessing data stored into the file.

You can use memory mapping to both read and write files. Every access performed to memory is reflected in the corresponding position in the file.

This is a typical sequence of system calls in order to map a file into memory:

1. A call to the `CreateFile` system call to open the file and obtain a handle to the file.
2. A call to the `CreateFileMapping` system call to create a mapped file object.
3. One or more calls to `MapViewOfFile` and `UnmapViewOfFile` to map and release portions of a file into memory. In a typical usage, the whole file is mapped at once in memory.
4. A call to `CloseHandle` to release the file.

The PInvoke interface to the required functions involves simple type mappings, as is usual for Win32 API functions. All the functions are in `kernel32.dll`, and the signature can be found in the Windows SDK. Listing 18-1 contains the definition of the F# wrapper for memory mapping.

The `SetLastError` parameter informs the runtime that the called function uses the Windows mechanism for error reporting and that the `GetLastError` function can be read in case of error; otherwise, the CLR ignores such a value. The `CharSet` parameter indicates the character set assumed, and it's used to distinguish between ANSI and Unicode characters; with `Auto`, you delegate the runtime to decide the appropriate version.

You can define the generic class `MemMap` that uses the functions to map a given file into memory. The goal of the class is to provide access to memory mapping in a system in which memory isn't directly accessible, because the runtime is responsible for its management. A natural programming abstraction to expose the memory to F# code is to provide an array-like interface in which the memory is seen as a homogeneous array of values.

### *Listing 18-1. Exposing memory mapping in F#*

```
module MMap =
    open System
    open System.IO
    open System.Runtime.InteropServices
```

```

open Microsoft.FSharp.NativeInterop
open Printf

type HANDLE = nativeint
type ADDR = nativeint

[<DllImport("kernel32", SetLastError = true)>]
extern bool CloseHandle(HANDLE handler)

[<DllImport("kernel32", SetLastError = true, CharSet = CharSet.Auto)>]
extern HANDLE CreateFile(string lpFileName,
    int dwDesiredAccess,
    int dwShareMode,
    HANDLE lpSecurityAttributes,
    int dwCreationDisposition,
    int dwFlagsAndAttributes,
    HANDLE hTemplateFile)

[<DllImport("kernel32", SetLastError = true, CharSet = CharSet.Auto)>]
extern HANDLE CreateFileMapping(HANDLE hFile,
    HANDLE lpAttributes,
    int flProtect,
    int dwMaximumSizeLow,
    int dwMaximumSizeHigh,
    string lpName)

[<DllImport("kernel32", SetLastError = true)>]
extern ADDR MapViewOfFile(HANDLE hFileMappingObject,
    int dwDesiredAccess,
    int dwFileOffsetHigh,
    int dwFileOffsetLow,
    int dwNumBytesToMap)

[<DllImport("kernel32", SetLastError = true, CharSet = CharSet.Auto)>]
extern HANDLE OpenFileMapping(int dwDesiredAccess,
    bool bInheritHandle,
    string lpName)

[<DllImport("kernel32", SetLastError = true)>]
extern bool UnmapViewOfFile(ADDR lpBaseAddress)

let INVALID_HANDLE = new IntPtr(-1)
let MAP_READ = 0x0004
let GENERIC_READ = 0x80000000
let NULL_HANDLE = IntPtr.Zero
let FILE_SHARE_NONE = 0x0000
let FILE_SHARE_READ = 0x0001
let FILE_SHARE_WRITE = 0x0002
let FILE_SHARE_READ_WRITE = 0x0003
let CREATE_ALWAYS = 0x0002
let OPEN_EXISTING = 0x0003

```

```

let OPEN_ALWAYS = 0x0004
let READONLY = 0x00000002

type MemMap<'T when 'T : unmanaged> (fileName) =

    let ok =
        match typeof<'T> with
        | ty when ty = typeof<int> -> true
        | ty when ty = typeof<int32> -> true
        | ty when ty = typeof<byte> -> true
        | ty when ty = typeof<sbyte> -> true
        | ty when ty = typeof<int16> -> true
        | ty when ty = typeof<uint16> -> true
        | ty when ty = typeof<int64> -> true
        | ty when ty = typeof<uint64> -> true
        | _ -> false

    do if not ok then failwithf "the type %s is not a basic blittable type" ((typeof<'T>).
ToString())
    let hFile =
        CreateFile (fileName,
                    GENERIC_READ,
                    FILE_SHARE_READ_WRITE,
                    IntPtr.Zero, OPEN_EXISTING, 0, IntPtr.Zero )
    do if (hFile.Equals(INVALID_HANDLE)) then
        Marshal.ThrowExceptionForHR(Marshal.GetHRForLastWin32Error());
    let hMap = CreateFileMapping (hFile, IntPtr.Zero, READONLY, 0, 0, null)
    do CloseHandle(hFile) |> ignore
    do if hMap.Equals(NULL_HANDLE) then
        Marshal.ThrowExceptionForHR(Marshal.GetHRForLastWin32Error());

    let start = MapViewOfFile (hMap, MAP_READ, 0, 0 ,0)

    do if (start.Equals(IntPtr.Zero)) then
        Marshal.ThrowExceptionForHR(Marshal.GetHRForLastWin32Error())

    member m.AddressOf(i : int) : 'T nativeptr =
        NativePtr.ofNativeInt(start + (nativeint i))

    member m.GetBaseAddress (i : int) : int -> 'T =
        NativePtr.get (m.AddressOf(i))

    member m.Item with get(i : int) : 'T = m.GetBaseAddress 0 i

    member m.Close() =
        UnmapViewOfFile(start) |> ignore;
        CloseHandle(hMap) |> ignore

    interface IDisposable with
        member m.Dispose() = m.Close()

```

The class exposes two properties: `Item` and `Element`. The former returns a function that allows access to data in the mapped file at a given offset using a function; the latter allows access to the mapped file at a given offset from the origin.

This example uses the `MemMap` class to read the first byte of a file:

```
let mm = new MMap.MemMap<byte>("somefile.txt")

printf "%A\n" (mm.[0])

mm.Close()
```

Memory mapping provides good examples of how easy it can be to expose native functionalities into the .NET runtime and how F# can be effective in this task. It's also a good example of the right way to use `PInvoke` to avoid calling `PInvoked` functions directly and build wrappers that encapsulate them. Verifiable code is one of the greatest benefits provided by virtual machines, and `PInvoke` signatures often lead to nonverifiable code that requires high execution privileges and risks corrupting the runtime's memory.

A good approach to reducing the amount of potentially unsafe code is to define assemblies that are responsible for accessing native code with `PInvoke` and that expose functionalities in a .NET verifiable approach. This way, the code that should be trusted by the user is smaller, and programs can have all the benefits provided by verified code.

## Wrapper Generation and Limits of `PInvoke`

`PInvoke` is a flexible and customizable interface, and it's expressive enough to define prototypes for most libraries available. In some situations, however, it can be difficult to map directly the native interface into the corresponding signature. A significant example is function pointers embedded into structures, which are typical C programming patterns that approximate object-oriented programming. Here, the structure contains a number of pointers to functions that can be used as methods; but you must take care to pass the pointer to the structure as the first argument to simulate the `this` parameter. Oracle's Berkeley Database (BDB) is a popular database library that adopts this programming pattern. The core structure describing an open database is:

```
struct __db {
    /* ... */
    DB_ENV *dbenv;           /* Backing environment. */
    DBTYPE type;            /* DB access method type. */
    /* ... */
    int (*close) __P((DB *, u_int32_t));
    int (*cursor) __P((DB *, DB_TXN *, DBC **, u_int32_t));
    int (*del) __P((DB *, DB_TXN *, DBT *, u_int32_t));
    // ...
}
```

The `System.Runtime.InteropServices.Marshal` class features the `GetFunctionPointerForDelegate` for obtaining a pointer to a function that invokes a given delegate. The caller of the function must guarantee that the delegate object will remain alive for the lifetime of the structure, because stubs generated by the runtime aren't moved by the garbage collector but can still be collected. Furthermore, callbacks must adopt the `stdcall` calling convention: if this isn't the case, the `PInvoke` interface can't interact with the library.

When `PInvoke`'s expressivity isn't enough for wrapping a function call, you can still write an adapter library in a native language such as C. This is the approach followed by the `BDB#` library, in which an intermediate layer of code has been developed to make the interface to the library compatible with

PInvoke. The trick has been, in this case, to define a function for each database function, taking as input the pointer to the structure and performing the appropriate call:

```
DB *db;
// BDB call
db->close(db, 0);
// Wrapper call
db_close(db, 0);
```

The problem with wrappers is that they must be maintained manually when the signatures of the original library change. The intermediate adapter makes it more difficult to maintain the code's overall interoperability.

Many libraries have a linear interface that can be easily wrapped using PInvoke, and, of course, wrapper generators have been developed. At the moment, there are no wrapper generators for F#, but the C-like syntax for PInvoke declarations makes it easy to translate C# wrappers into F# code. An example of such a tool is SWIG, which is a multilanguage wrapper generator that reads C header files and generates interop code for a large number of programming languages, such as C#.

## Summary

In this chapter, you saw how F# can interoperate with native code in the form of COM components and the standard Platform Invoke interface defined by the ECMA and ISO standards. Neither mechanism is dependent on F#, but the language exposes the appropriate abstractions built into the runtime. You studied how to consume COM components from F# programs and vice versa, and how to access DLLs through PInvoke.



# Packaging, Debugging and Testing F# Code

Successful programming must involve a healthy marriage of *good code* with *good software engineering* techniques and practice. Sometimes these overlap: functional programming is a good software-engineering technique: among other benefits, anecdotal evidence indicates that functional programming frequently leads to a substantially reduced bug rate for good programmers. This is primarily because programs built using functional techniques tend to be highly compositional, building correct programs out of correct building blocks. The functional-programming style avoids or substantially reduces the use of side effects in the program, one property that makes programs more compositional. Debugging and testing are still essential activities to ensure that a program is as close as possible to its specifications, however. Bugs and misbehaviors are facts of life, and F# programmers must learn techniques to find and remove them. Often, these techniques are not inherently “functional” or even particularly “code” related, but they are still critical to the process of writing robust, maintainable, and successful software components.

You also need to learn many pragmatics of building and packaging F# code. As a result, this chapter turns to the pragmatics of *packaging*, *debugging*, and *testing* F# code.

## Packaging Your Code

To begin your exploration of ways to package F# code, let's first talk about the sorts of things you may be building with F#.

## Mixing Scripting and Compiled Code

Small programs are often used both as interactive scripts and as small compiled applications. Here are some useful facts to know about scripting with F# and F# Interactive:

- F# scripts use the extension `.fsx`.
- A script file can contain `#r` directives. These reference a library or a type provider.
- A script file can contain `#load` directives. This is as if the files had been compiled using the command-line compiler and included in the same assembly as the referencing script.

- A script that is referenced via a #load can itself contain further #load and #r references. This means that a script can act like a “little library.” If the same root file transitively references the same script more than once via #load, the file acts as if it is logically only referenced once.
- You can access command-line arguments from within scripts by using the expression `fsi.CommandLineArgs`. Within compiled code, use `System.Environment.GetCommandLineArgs`. Within code used in both modes, use conditional compilation to switch between these, as shown in the next coding example.
- You can run a script on startup by using the `--exec` command-line option for `fsi.exe` or by giving a single file name on the command line. You can find other command-line options by using `fsi.exe --help`.

Conditional compilation is a particularly useful feature for scripts—especially the predefined conditional compilation symbols `COMPILED` and `INTERACTIVE`. The former is set whenever you compile code using the command-line compiler, `fsc.exe`, and the latter is set whenever you load code interactively using F# Interactive. A common use for these flags is to start the GUI event loop for a Windows Forms or other graphical application, such as using `System.Windows.Forms.Application.Run`. F# Interactive starts an event loop automatically, so you require a call to this function in the compiled code only:

```
open System.Windows.Forms

let form = new Form(Width = 400, Height = 300,
                  Visible = true, Text = "F# Forms Sample")
#if COMPILED
// Run the main code
System.Windows.Forms.Application.Run(form)
#endif
```

---

■ **Note:** You can specify additional conditional compilation directives by using the `--define` command-line compiler option.

---

## Choosing Optimization Settings

The F# compiler comes with a simple choice of optimization levels. You nearly always want to compile your final code using `--optimize`, which applies maximum optimizations to your code. This is also the default optimization setting when using `fsc.exe` or `fsi.exe` directly, but it is not the default for compiled code using Visual Studio’s “Debug” mode.

The F# compiler is a cross-module, cross-assembly optimizing compiler, and it attaches optimization information to each assembly you create when using optimization. This information may contain some code fragments of your assembly, which may be inlined into later assemblies by the optimizing compiler. In some situations, you may not want this information included in your assembly. For example, you may expect to independently version assemblies, and in this case, you may want to ensure that code is never duplicated from one assembly to another during compilation. In this case, you can use the `--nooptimizationdata` switch to prevent optimization data being recorded with the assemblies that you create.



## Generating Documentation

In Chapter 2, you saw that comments beginning with `///` are XML documentation comments, which are used by interactive tools such as Visual Studio. They can also be collected to generate either HTML or XML documentation. You generate HTML documentation using an auxiliary tool, such as `FsHtmlDoc`, which is available in the F# Power Pack.

You can also generate a simple XML documentation file using the `--doc` command-line option. You must name the output file. For example, using `fsc -a --doc:whales.xml whales.fs` for the code in Listing 7-11 in Chapter 7 generates the file `whales.xml` containing:

---

```
<?xml version="1.0" encoding="utf-8"?>
<doc>
  <assembly><name>whales</name></assembly>
  <members>
    <member name="T:Whales.Fictional.WhaleKind">
      <summary> The three kinds of whales we cover in this release</summary>
    </member>
    <member name="P:Whales.Fictional.bluey">
      <summary> The backup whale</summary>
    </member>
    <member name="P:Whales.Fictional.moby">
      <summary>The main whale</summary>
    </member>

    <member name="P:Whales.Fictional.orca">
      <summary> This whale is for experimental use only</summary>
    </member>
    <member name="P:Whales.Fictional.whales">
      <summary> The collected whales</summary>
    </member>
    <member name="T:Whales.Fictional">
      </member>
  </members>
</doc>
```

---

## Building Shared Libraries

You usually need to share libraries among multiple applications. You can do this by using any of these techniques:

- Including the same library source file in multiple projects and/or compilations
- Duplicating the DLL for the library into each application directory
- Creating a library and sharing it using a package-sharing tool such as NuGET
- Creating a strong name-shared library and installing it on the target machine

This section covers the last option in more detail. A strong name-shared library has the characteristics:

- It's a DLL.

- You install it in the .NET global-assembly cache (GAC) on the target machine.
- You give it a strong name by using `--keyfile`. This corresponds to project-signing options in the MonoDevelop and Visual Studio settings.
- You package all of its supporting data files using `--linkresource`. This corresponds to “EmbeddedResource” in the MonoDevelop and Visual Studio settings.
- You (optionally) give it a version number using an `AssemblyVersion` attribute in your code.
- You ensure that all of its dependencies are shared libraries.

The usual place to install shared libraries is the .NET GAC. The GAC is a collection of assemblies installed on the machine and available for use by any application that has sufficient privileges. Most libraries used in this book, such as `System.Windows.Forms.dll`, are installed in the GAC when you install the .NET Framework on a machine.

The remaining requirements are easy to satisfy and are conditions that must hold before you install something in the GAC. For example, assemblies must have strong names. All assemblies have names; for example, the assembly `whales.dll` (which you compiled in the earlier “Compiling DLLs” section using `fsc -a whales.fs`) has the name `whales`. An assembly with a strong name includes a hash using a cryptographic public/private key pair. This means that only people who have access to the private key can create a strong-named assembly that matches the public key. Users of the DLL can verify that the contents of the DLL were generated by someone holding the private key. A strong name looks something like:

---

```
mscorlib, Version=2.0.0.0, Culture=neutral, PublicKeyToken=b77a5c561934e089
```

---

It's easy to create a strong-named assembly: generate a public/private key pair using the `sn.exe` tool that comes with the .NET Framework SDK, and give that as your keyfile argument. You can install libraries into the GAC using the .NET Framework SDK utility `gacutil.exe`. This command-line session shows how to do this for the code shown in Listing 7-11, again in Chapter 7:

---

```
C:\Users\dsyme\Desktop> sn.exe -k whales.snk
```

```
Microsoft (R) .NET Framework Strong Name Utility Version 4.0.30319.17929  
Copyright (c) Microsoft Corporation. All rights reserved.
```

```
Key pair written to whales.snk
```

```
C:\Users\dsyme\Desktop> fsc -a --keyfile:whales.snk whales.fs  
Microsoft (R) F# Compiler version 11.0.50727.1  
Copyright (c) Microsoft Corporation. All Rights Reserved.
```

```
C:\Users\dsyme\Desktop> gacutil /i whales.dll  
Microsoft (R) .NET Global Assembly Cache Utility. Version 4.0.30319.17929  
Copyright (c) Microsoft Corporation. All rights reserved.
```

```
Assembly successfully added to the cache
```

---

Installer generators, such as WiX, also include directives to install libraries into the GAC. Installer generators are discussed later in this chapter.

---

■ **Note:** If you're planning to write libraries for use by the rest of the world, we recommend that you take the time to read the .NET library design guidelines, document them using XML and HTML docs, and learn how to version your libraries. Chapter 20 takes a deeper look at guidelines for library design.

---

## Using Static Linking

Sometimes, applications use a DLL as a library, but when it comes to deploying the application on a Web site or as installed software, it may be easier to bundle that DLL as part of the application. You can do this in two ways: by placing the DLL alongside the EXE for the application or by statically linking the DLL when you create the EXE. You select the DLL by using the `--staticlink` compiler option with the assembly name of the DLL.

You can also bundle the F# libraries into your application to give a zero-dependency application. You statically link all DLLs that depend on the F# libraries by using the `--standalone` compiler option.

Static linking can cause problems in some situations and should be used only for a final EXE or a DLL used as an application plug-in.

## Packaging Different Kinds of Code

Table 19-1 lists some of the kinds of software implemented with F#. These tend to be organized in slightly different ways and tend to use encapsulation to varying degrees. For example, encapsulation is used heavily in frameworks but not when you're writing 100-line scripts.

*Table 19-1. Some kinds of software built using F#*

Software Entity	Description
Script	A program or set of program fragments, usually in a single file and fewer than 1,000 lines, usually with an <code>.fsx</code> extension, run through F# Interactive. Sometimes also compiled. Organized using functions and occasional type definitions. Freely uses static global state. Usually has no signature file or accessibility annotations.
Application	An EXE or a web application DLL, perhaps with some supporting DLLs. Organized using namespaces, modules, functions, and some abstract types. Often uses some static global state. Some internal files and data structures may have signatures, but often these aren't needed.
Application extension (plug-in or add-on)	A component that extends an application, often compiled as a DLL containing types along with an accompanying XML file that describes the plug-in to the application. The host application loads the DLLs using .NET reflection. Generally has no static state because this lets the application instantiate multiple instances of the plug-in. Example: the DLL plug-ins for Visual Studio, MonoDevelop.
Type Provider	A specific application extension that extends the resolution logic of the F# compiler, F# Interactive, and the F# editing tools.
Framework	A collection of related type definitions, functions, and algorithms organized according to established .NET and F# library-design guidelines. Usually compiled as a DLL, strong-name signed, installed into the GAC on the target machine, and versioned as an independent entity. Generally has no static state except where it mediates essential state on the host computer or operating system.

---

Software Entity	Description
Framework extension	A component that extends a framework, usually by defining types that implement particular interfaces. Organized in an appropriate namespace as a simple set of classes and functions that generate objects that implement the interfaces defined in a framework. Generally has no static state. Example: the Firebird.NET API, which provides implementations of the ADO.NET Data Access framework interfaces to enable access to Firebird databases.

## Using Data and Configuration Settings

So far, this book has focused on code. In reality, almost every program comes with additional data resources that form an intrinsic part of the application. Common examples of the latter include the resource strings, sounds, fonts, and images for GUI applications. Applications typically select among different data resources based on language or culture settings. Often, programs also access additional parameters, such as environment variables derived from the execution context or registry settings recording user-configuration options. It can be useful to understand the idioms used by .NET to make managing data and configuration settings more uniform. Table 19-2 shows some terminology used for data resources.

*Table 19-2. Application data: Terminology*

Terminology	Meaning	Example
Static application data	A data resource whose name/location is always known, whose value doesn't change during execution, and that your application can generally assume always exists.	The PATH environment variable or a data file distributed with your application.
Strongly typed data	Data accessed as a named, typed .NET value through code written by you or generated by a tool you're using. The code hides the complexity of locating and decoding the resource.	An icon data resource decoded to a System.Drawing.Icon value. The ResGen.exe tool can generate strongly typed APIs for common Windows resources, such as bitmaps and icons.
GUI resource	A string, a font, an icon, a bitmap, an image, a sound, or another binary resource that is attached to a Windows application or DLL using the Win32 .res format or .NET managed .resx format. Often dependent on language/culture settings.	A bitmap added as a resource to a Windows Forms application or to an error message from a compiler.

You may need to access many different kinds of data resources and application settings. Table 19-3 summarizes the most common ones.

**Table 19-3.** *Commonly used data and configuration settings*

<b>Data Resource</b>	<b>Notes</b>
Source directory	The source directory containing the source file(s) at time of compilation. Often used to access further resources in F# Interactive scripts or for error reporting in compiled applications. Accessed using the <code>__SOURCE_DIRECTORY__</code> predefined identifier.
Command arguments	Arguments passed to the invocation of the program. Accessed using <code>System.Environment.CommandLineArgs</code> and <code>fsi.CommandLineArgs</code> when running in F# Interactive.
Installation location	Where a program EXE or DLL is installed. Accessed by using <code>System.Windows.Forms.Application.StartupPath</code> or by reading the <code>Assembly.Location</code> of any of the types defined in your assembly. For F# Interactive scripts, the installation location is usually the same as the source directory.
User directories	Paths to common logical directories, such as Program Files, My Documents, and Application Data. Accessed using <code>System.Environment.GetFolderPath</code> .
Environment variables	User- or machine-wide settings, such as PATH and COMPUTERNAME. Accessed using <code>System.Environment.EnvironmentVariable</code> .
Registry settings	User- or machine-wide settings used to hold the vast majority of settings on a Windows machine. Accessed using <code>Microsoft.Win32.Registry.GetValue</code> and related types and methods.
Configuration settings	Database connection strings and other configuration settings, often used for Web applications. If an application is called <code>MyApp.exe</code> , this is usually stored in a file such as <code>MyApp.exe.config</code> alongside the executable; web applications use a <code>Web.Config</code> file. Accessed using <code>System.Configuration.ConfigurationManager</code> .
Isolated storage	A special storage area accessible only to an installed application and that looks just like disk storage.
Fonts, colors, icons, and so on	Specifications of Windows-related resources. Often taken from predefined system fonts and colors using the functions in <code>System.Drawing</code> ; for example, <code>Color.MidnightBlue</code> or <code>new Font(FontFamily.GenericMonospace, 8.0f)</code> . Can be added as a binary resource to an assembly and accessed using <code>System.Resources.ResourceManager</code> .

You can author GUI data resources, such as fonts, images, strings, and colors, by creating a `.resx` file using a tool such as Visual Studio. You then compile them to binary resources by using the `resgen.exe` tool that is part of the .NET Framework SDK. Most development environments have tools for designing and creating these resources. Often, the .NET Framework contains a canonical type, such as `System.Drawing.Color`, for any particular kind of resource; avoid writing needless duplicate types to represent them.

Sometimes it's a good idea to make sure a data resource is officially part of an assembly. For example, this is required if the assembly will be installed into the GAC. You can embed resources in applications (or associate them with a DLL) by using the `--resource` compiler option.

## Debugging Your Code

Programming systems such as .NET support debugging as a primary activity through tools to help you inspect programs for possible errors. The debugger is one of the most important of these tools, and it

allows you to inspect the program state during execution. You can execute the program stepwise and analyze its state during execution.

---

## DEBUGGABLE PROGRAMS

---

The debugger requires support from debugged programs in order to work properly. For interpreted languages, the interpreter supervises program execution, and the debugger must interact with it. Compiled languages, on the other hand, must include this support during compilation so that the debugger can properly interact with the running program.

The CLR provides support for program debugging, and compiled programs provide information to the debugger via a file with a .pdb file extension, which is the program-debugging database. Because the compilation process maps high-level programming constructs into equivalent ones in a less expressive language (in this case, the intermediate language), some information gets lost during this process even if the semantics of the program are preserved. For example, in the intermediate language, the names of local variables are referred to as indexes into an array rather than names. A database is used to preserve the information about the correspondence between the program instructions and the intermediate language instructions. The debugging infrastructure uses it to create the illusion that the program is interpreted at the language level, showing the current line of execution in the source code rather than the one in the compiled—and actually running—program. The database retains correspondence among intermediate-language instructions (and those that have been used to generate them) and other important information, such as local variable names, that is lost during compilation. The program database is language independent, so the debugger tool can be shared among programming languages, and you can analyze the program execution even when a program has been developed with different languages. It's also possible to step through unmanaged code from managed code, and vice versa.

Debugging without the .pdb file is possible, although the debugger is incapable of showing the source code; instead, the intermediate code or the machine code is shown to the user.

---

Let's start with the following simple function, which is in principle meant to return true if the input string is a palindrome and false otherwise:

```
let isPalindrome (str : string) =
    let rec check(s : int, e : int) =
        if s = e then true
        elif str.[s] <> str.[e] then false
        else check(s + 1, e - 1)

    check(0, str.Length - 1)
```

The function appears correct at first sight. It works only for strings with an odd number of characters and strings with an even length that aren't palindromes, however. In particular, the program raises an exception with the "abba" string as input.

Let's see how to use the Visual Studio debugger to figure out the problem with this simple function. The algorithm recursively tests the characters of the string pairwise at the beginning and at the end of the string, because a string is a palindrome if the first and last characters are equal and the substring obtained by removing them is a palindrome too. The *s* and *e* variables define the boundaries of the string to be tested and initially refer to the first and last characters of the input string. Recursion terminates when the outermost characters of the string to be tested differ or when you've tested the whole string and the indexes collide.

Figure 19-1 shows the debugging session of the simple program. You set a breakpoint at the instruction that prints the result of the `isPalindrome` function for the "abba" string by clicking where the red circle is shown, which indicates the location of the breakpoint. When you start the program in debug mode, its execution stops at the breakpoint, and you can step through the statements. The current instruction is indicated by the yellow arrow, and the current statement is highlighted, as shown in Figure 19-1.

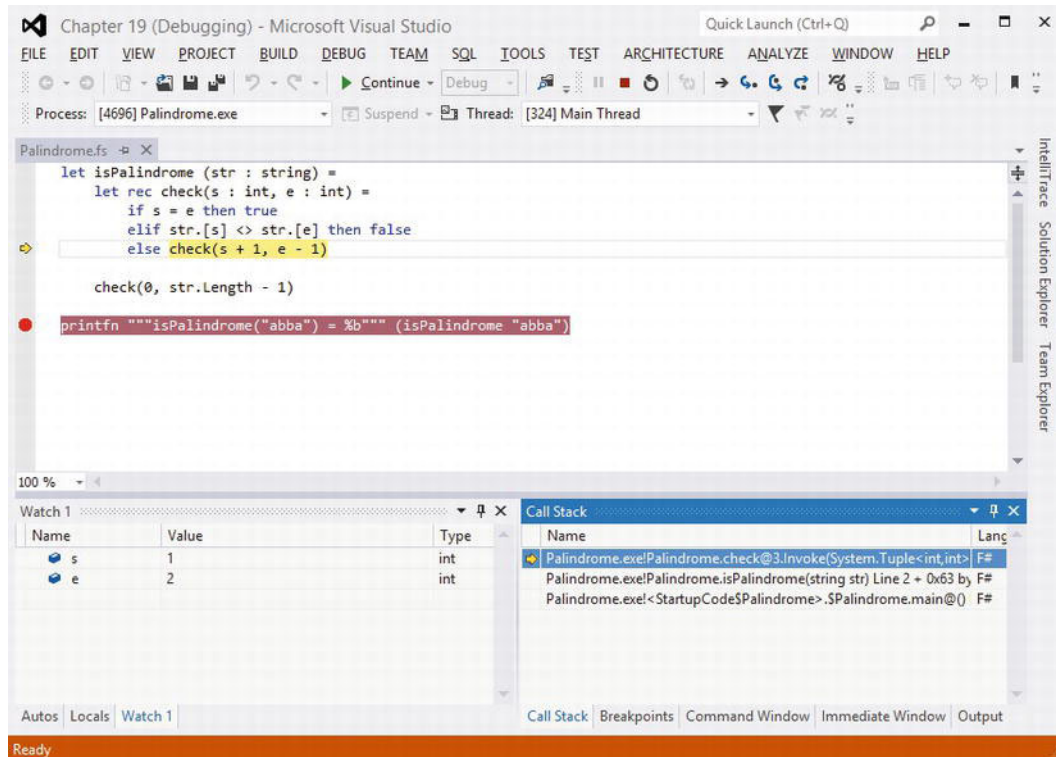

Figure 19-1. The Visual Studio debugger

You can access the state of the program through a number of windows that show different aspects of the running program and that are usually docked at the bottom of the debugging window. For instance, you can inspect the state of the local variables of the current method (the Locals window shows the local variables and arguments, `e` and `s` in this example) or the state of the call stack to see the sequence of method calls (the Call Stack window). The Watch view lets you write variable names and simple expressions and watch them change during execution. You can also evaluate expressions in the Immediate window and invoke methods, as shown in Figure 19-1, where the simple expressions `e` and `s` are used. More views are available through the Debug menu, including the state of executing threads and the memory.

This simple example examines why `isPalindrome` misbehaves for an input string of even length. As shown in Figure 19-1, the Watch window is used to monitor the `s` and `e` variables intended to define the bounds of the substring that has yet to be checked; in this case, the two indexes cross without ever becoming equal, which is the criterion used to successfully stop the recursion. This happens when `s` has value 2 and `e` has value 1 in the example. The symptom of the function misbehavior is that an exception is thrown; this is frequently where debugging starts. In this example, the exception is thrown a few steps forward, when `e` gets value -1, which is an invalid index for accessing a character in a string. If you used

`str[e]` as the watch expression or in the Immediate window, the problem would be evident. In more complicated situations, the ability to inspect the application state when the exception is raised makes it possible to determine what conditions to break on and where to set breakpoints before a bug occurs. Now that you've found the bug, you can fix it by extending the test from `s = e` to `s >= e` to ensure that even if the end index becomes smaller than the starting index, you deal with the situation appropriately.

---

■ **Note:** In Visual Studio and other Microsoft .NET debugging tools, debugger expressions follow the C# syntax, and arrays don't require the dot before the square braces. The most noticeable difference between C# and F# expression syntax is that access to arrays uses `[ ]` rather than `. [ ]` and the equality operator is `==` rather than `=`.

---

## Using More Features of the Visual Studio Debugger

This section focuses on relevant aspects of the debugging facilities that the CLR provides to managed applications via tools such as the Visual Studio debugger.

Consider the notion of a *breakpoint*—an essential tool to mark a statement in a program where you want to suspend execution and inspect the program state. Often, a bug appears only under very specific conditions. Trivial bugs, such as the one discussed earlier, are the easiest to track and the first to be fixed in a program. It can be difficult or even impossible to selectively suspend program execution at a statement only when certain conditions are met. Many programmers introduce an `if` statement with a dummy statement for the body and set the breakpoint to the statement to suspend the program under the defined condition. This requires a recompilation of the program and a change to the source code, which may lead to further problems, particularly when several points of the program must be kept under control. A more effective strategy is to use *conditional breakpoints*, a powerful tool offered by the debugger. When you right-click a breakpoint in the editor window or in the Breakpoints window (accessible through the Debug menu), a number of additional options become available.

For each breakpoint you can indicate:

- *A condition:* An expression that must be satisfied by the program state in order to suspend program execution
- *A hit count:* The number of times the breakpoint should be hit before suspending execution
- *A filter:* A mechanism to filter the machine, process, and thread to select the set of threads that will be suspended when the breakpoint is hit
- *An action:* Something to be executed when the breakpoint is hit

Breakpoint conditions and hit counts are the most frequently used options. A hit count is useful when a bug appears only after a significant period of execution. For instance, when you're debugging a search engine, a bug may occur only after indexing gigabytes of data; the number of hits of the breakpoint can be determined.<sup>1</sup> Conditional expressions are more useful when it's difficult to reproduce the exact circumstances that trigger a bug and when the number of times the breakpoint is hit is variable. For expressions entered in the Immediate window, conditional expressions are expressed as in C#; this is true

---

<sup>1</sup>One of the authors became a fan of this approach when a program he was writing crashed only after crunching 2GB of input data. The ability to stop the program immediately before the crash made it possible to find a particular input sequence that was unexpected. It would have been very difficult to find this bug by printing the state of the application.



for all languages, because the debugger infrastructure within the CLR is designed to deal with compiled programs and ignores the source language.

Sometimes you need to debug a running program that has been started without the debugger; a typical situation is one in which you're debugging a service started through the Service snap-in of the Management Console or debugging a Web application live that is executed by IIS rather than by the Web server used for development by Visual Studio. In these situations, you can attach the debugger to a running process by selecting Tools ► Attach to Process and selecting the process to debug. There are standard processes that are generally known to programmers: `w3p.exe` is used by IIS to run application pools where ASP.NET applications run, and the `svchost.exe` process generally hosts Windows services. Sometimes, however, it can be difficult to find out which process is running the code to debug, because several of these generic process hosts run applications.

Debugging a program significantly slows down its execution speed because the debugger infrastructure injects code to monitor program execution. Conditional breakpoints tend to worsen the situation, because every time the breakpoint is hit, the condition must be tested before standard execution resumes.

The CLR debugging infrastructure operates at the level of compiled assemblies. This has several implications. The objects and types that are visible to the debugger are those generated by the compiler and aren't always explicitly defined by you in the source code. The program database information tends to preserve the mapping between the source and the compiled program, but sometimes, the underlying structure surfaces to the user. On the other hand, you can debug programs written in different programming languages, even when managed and unmanaged code must interoperate.

---

■ **Note:** One tricky problem with F# programs is debugging *tail calls*. (Chapter 8 described tail calls.) In particular, when a tail call is executed, the calling stack frame is removed prior to the call. This means that the calls shown in the Visual Studio call stack window may not be complete. Entries may be missing that should, logically speaking, be present, according to the strict call sequence that caused a program to arrive at a particular point. Likewise, the debugger commands `step-into` and `step-out` can behave a little unusually when stepping into a tail call. This behavior may be absent for programs compiled for debugging because many optimizations are disabled, but it appears when you're debugging a program compiled for release.

---

Figure 19-2 shows a debugging session for the program discussed in Chapter 18; you've stepped into the `HelloWorld` method, which is a C function accessed through the `PlInvoke` interface as witnessed by the Call Stack window. To enable cross-language debugging, indicate in the project options' Debug section that the debugging scope is the whole program rather than the current project.

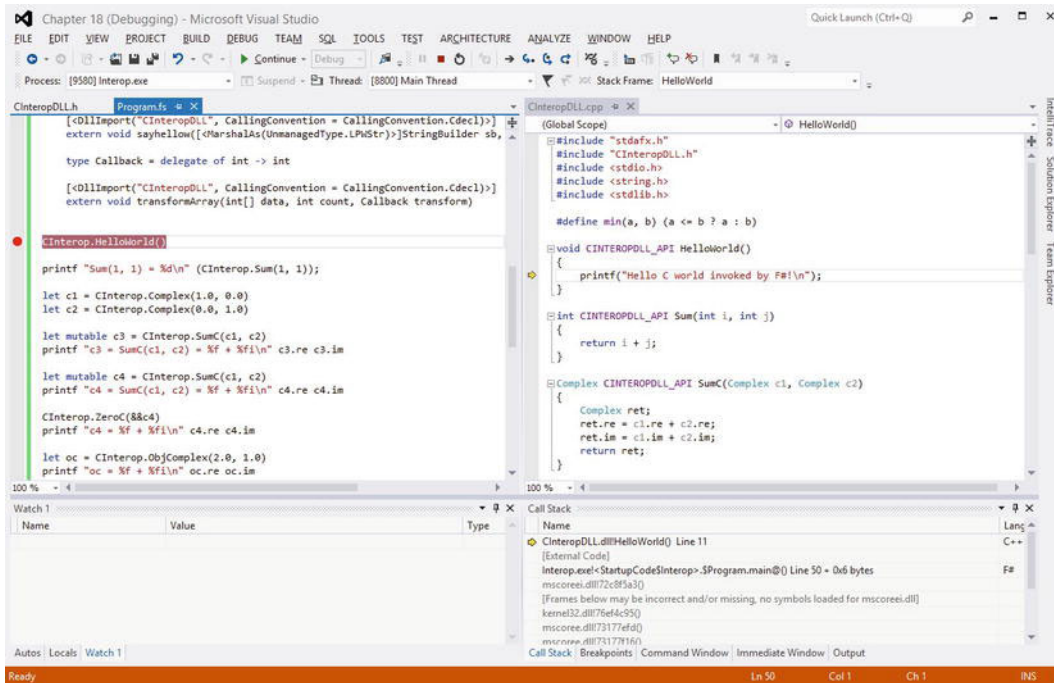

Figure 19-2. Cross-language debugging with the Visual Studio debugger

## Instrumenting Your Program with the System.Diagnostics Namespace

A managed application can programmatically access the debugging services of the CLR through the types contained in the `System.Diagnostics` namespace. Several types in the namespace encompass aspects of the runtime, including stack tracing, communicating with the debugger, accessing performance counters to read statistics about the computer state (memory and CPU usage are typically available using them), and handling operating system processes.

This section focuses on the classes related to debugging and the debugger. You can interact with the debugging infrastructure in three primary ways:

- The `Debug` class programmatically asserts conditions in the program and outputs debugging and tracing information to debuggers and other listeners.
- The `Debugger` class interacts with the debugger, checks whether it's attached, and triggers breaks explicitly from the program.
- The debugging attributes are a set of custom attributes that you can use to annotate the program to control its behavior (see Chapters 9 and 10 for more information about custom attributes).

The `Debug` class provides a way to output diagnostic messages without assuming that the program has been compiled as a console application; the debug output is collected by one or more *listeners* that receive the output notifications and do something with them. Each listener is an instance of a class inherited from the `TraceListener` class and typically sends the output to the console or to a file, or notifies the user with a

dialog box (you can find more information about how to write a listener in the class library documentation). The following example instruments the `isPalindrome` function with tracing statements:

```
open System.Diagnostics

let isPalindrome (str : string) =
    let rec check(s : int, e : int) =
        Debug.WriteLine("check call")
        Debug.WriteLineIf((s = 0), "check: First call")
        Debug.Assert((s >= 0 || s < str.Length), sprintf "s is out of bounds: %d" s)
        Debug.Assert((e >= 0 || e < str.Length), sprintf "e is out of bounds: %d" e)
        if s = e || s = e + 1 then true
        else if str.[s] <> str.[e] then false
        else check(s + 1, e - 1)
    check(0, str.Length - 1)
```

The `WriteXXX` methods of the `Debug` class output data of a running program are a sophisticated version of the `printf` debugging approach, where the program is enriched with print statements that output useful information about its current state. In this case, however, you can redirect all the messages to different media rather than just print them to the console. You can also conditionally output messages to reduce the number of messages sent to the debug output. The example outputs a message each time the `check` method is invoked and uses the conditional output to mark the first invocation.

---

■ **Note:** By default, the diagnostic output isn't sent to the console on Windows. When a program is executed in debugging mode in Visual Studio, the output is sent to the Output window. Otherwise, you need a tool such as `DebugView`, available on Microsoft TechNet. F# Interactive doesn't output any debug assertions being compiled for release.

---

*Assertions* are a well-known mechanism to assert conditions about the state of a running program, ensuring that at a given point in the program, certain preconditions must hold. For instance, assertions are often used to ensure that the content of an option-valued variable isn't `None` at some point in the program. During testing, ensure that if this precondition isn't satisfied, program execution is suspended as soon as possible. This avoids tracing back from the point where the undefined value of the variable would lead to an exception. The `Assert` method lets you specify a Boolean condition that must hold; otherwise, the given message is displayed, prompting the user with the failed assertion.

Both debug output and assertions are statements that typically are useful during program development, but when a release is made, these calls introduce unnecessary overhead. Often, the program compiled with these extra checks is called the *checked version* of the program. The .NET Framework designers devised a general mechanism to strip out the calls to methods under a particular condition with the help of the compiler. The `ConditionalAttribute` custom attribute is used to label methods whose calls are included in the program only if a given compilation symbol is defined; for the methods in the `Debug` type, it's the `DEBUG` symbol. The F# compiler supports this mechanism, making it possible to use these tools to instrument the F# program in a way that is supported by the .NET infrastructure.

The `Debugger` type lets you check whether the program is attached to a debugger and to trigger a break if required. You can also programmatically launch the debugger using this type and send log messages to it. This type is used less often than the `Debug` type, but it may be useful if a bug arises only when there is no attached debugger. In this case, you can programmatically start the debugging process when needed.

Another mechanism that lets you control the interaction between a program and the debugger is based on a set of custom attributes in the `System.Diagnostics` namespace. Table 19-4 shows the attributes that control in part the behavior of the debugger.

*Table 19-4. Attributes controlling program behavior under debug*

Attribute	Description
<code>DebuggerBrowsableAttribute</code>	Determines whether and how a member is displayed in the Debug window.
<code>DebuggerDisplayAttribute</code>	Indicates how a type or field should be displayed in the Debug window.
<code>DebuggerHiddenAttribute</code>	The debugger may interpret this attribute and forbid interaction with the member annotated by it.
<code>DebuggerNonUserCodeAttribute</code>	Marks code that isn't user written (for instance, designer-generated code) and that can be skipped to avoid complicating the debugging experience.
<code>DebuggerStepperBoundaryAttribute</code>	Locally overrides the use of <code>DebuggerNonUserCodeAttribute</code> .
<code>DebuggerStepThroughAttribute</code>	The debugger may interpret this attribute and disallow stepping into the target method.
<code>DebuggerTypeProxyAttribute</code>	Indicates a type that is responsible for defining how a type is displayed in the Debug window. It may affect debugging performance and should be used only when it's really necessary to radically change how a type is displayed.
<code>DebuggerVisualizerAttribute</code>	Indicates for a type the type that defines how to render it while debugging.

These attributes allow you to control two aspects of debugging: how data are visualized by the debugger and how the debugger should behave with respect to the visibility of members.

The ability to control how types are displayed by the debugger can help you produce customized views of data that may significantly help you inspect the program state in an aggregate view. The easiest way is to use `DebuggerDisplayAttribute`, which supports customizing the text associated with a value in the Debug window; an object of that type can still be inspected in every field. Consider the simple example:

```
open System
```

```
[<DebuggerDisplay("{re}+{im}i")>]
type MyComplex= {re : double; im : double}
```

```
let c = {re = 0.0; im = 0.0}
Console.WriteLine("{0}+{1}i", c.re, c.im)
```

Here, you introduce a record named `MyComplex` with the classic definition of a complex number. The `DebuggerDisplayAttribute` attribute is used to annotate the type so that the debugger displays its instances using the mathematical notation rather than just displaying the type name. The syntax allowed assumes that curly braces are used to indicate the name of a property whose value should be inserted in the format string. Figure 19-3 shows the result in the Visual Studio debugger: on the left is how the debugger window appears when `MyComplex` is without the `DebuggerDisplay` annotation; on the right, the custom string appears, with the properties in the string in curly braces. As you can see, the difference is in the value field,

and the structure can still be inspected. You can use a custom visualizer to fully customize the appearance of the data in the debugger, but it may affect debugging performance.

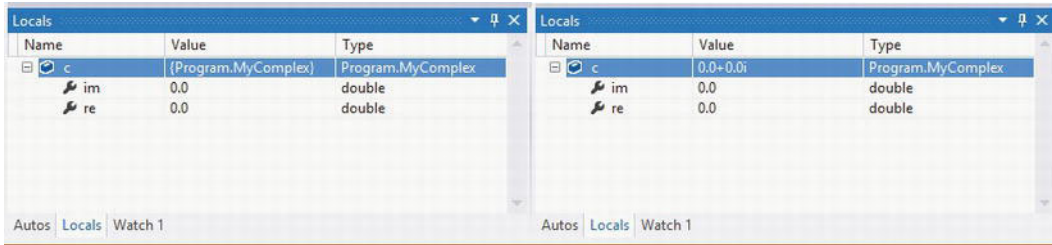

*Figure 19-3. The `MyComplex` type shown by the debugger without and with `DebuggerDisplay`*

Figure 19-3 is also interesting because it shows how the debugger displays information from the compiled program. In this case, the association between the name `c` and the runtime local variable has been lost, and the record appears because it has been compiled by the compiler as a pair of fields and public properties.

The rest of the namespace contains classes to interact with the runtime: the event-logging infrastructure, process, and thread management; and the representation of a thread's stack. Stack manipulation can be useful if you need to know the call sequence that leads to executing a particular method. The `StackTrace` type exposes a list of `StackFrame` objects that provide information about each method call on the stack.

## Debugging Concurrent and Graphical Applications

Although a debugger is a fundamental tool for inspecting applications, it isn't the Holy Grail, and it must be used carefully: the process interferes with an application's normal execution. The most relevant impact of the debugging process on a running program is the influence on execution timing, and graphical and concurrent programs are much more prevalent these days. Sometimes, a bug disappears while the debugger is being used, because of these changes in execution timing.

Debugging and testing concurrent applications can be particularly difficult, because using a debugger is guaranteed to alter execution timing. There is no general rule for debugging concurrent applications, but this section briefly discusses how you can use the debugger in these cases. Consider this simple example of a multithreaded application:

```
open System
open System.Threading

let t1 = Thread(fun () -> while true do printf "Thread 1\n")
let t2 = Thread(fun () -> while true do printf "Thread 2\n")

t1.Start(); t2.Start()
```

---

■ **Note:** If you run this example in F# Interactive, you must abort the thread explicitly by calling the `Abort` method, right-clicking the F# Interactive window, and choosing `Cancel Evaluation`. If it doesn't resume, you may have to kill the `fsi.exe` process that is using the CPU most. This is a common solution when a computation gets out of control during interactive sessions.

---

Threads `t1` and `t2` access the console, which is a shared resource; when you run the program without a debugger attached, the string printed by the two threads appears interleaved on the console. If you set a breakpoint on the two `printf` statements and start a debugging session, stepping automatically moves from one thread to the other; the output of the program is completely different from that obtained without debugging. This is true also if you disable the breakpoints. The output is even more unbalanced if you set the breakpoint in only one of the two threads.

Chapter 11 discussed shared-memory multithreaded applications. In such applications, shared objects accessed by different threads are critical resources that may be viewed in the debugger. If the debug of a single thread fails, setting breakpoints in different threads may help you study the dynamic of the application, even if the full interaction of the threads can't be fully simulated. If this approach fails, it may be useful to introduce tests inside the application and use the `Debugger` type only when a given condition occurs. Channel-based message-passing applications are generally easier to debug than those that rely on shared memory, because you can monitor the communication end points using breakpoints or logging messages. Although careful use of the debugger may help when you're debugging concurrent applications, sometimes, external observation is enough to influence a running program. In these cases, tracing through debug output becomes a viable alternative; large systems have different levels of traces to monitor program execution.

Graphical applications also present issues when you're debugging. As discussed in Chapter 16, a GUI application's event loop is handled by a single thread; if this is blocked, the application's GUI ceases working while it's suspended in the debugger. Consider the simple application:

```
open System
open System.Windows.Forms

let f = new Form(Text = "Hello world")
let b = new Button(Text = "Click me!", Dock = DockStyle.Fill)

b.Click.Add(fun _ ->
    b.Text <- "Click me again"
    MessageBox.Show("Hello world") |> ignore)

f.Controls.Add(b)
f.Show()
Application.Run(f)
```

If you set a breakpoint at the `MessageBox` statement and debug the application, when the button is clicked, the debugger suspends execution, and the form stops responding. The text of the button doesn't change until execution resumes, because the thread suspended by the debugger is responsible for handling GUI events, including the paint event that refreshes the button's content and updates the button label.

More specifically, event handlers can affect the appearance of a form in two ways: by setting properties of graphical controls and by explicitly drawing using a `Graphics` object. In the first case, the change isn't noticed until execution resumes; the property change usually asks for a refresh of the control's appearance, which eventually results in a paint event that must be processed by the thread that is suspended in the debugger. In the second case, updates are immediately visible when a statement involving drawing primitives is executed (unless double buffering has been enabled on the window).

For example, consider this program, which displays a window with a number of vertical lines:

```
open System
open System.Windows.Forms
open System.Drawing
```

```

let f = new Form(Text = "Hello world")

f.Paint.Add(fun args ->
    let g = args.Graphics

    for i = 0 to f.Width / 10 do
        g.DrawLine(Pens.Black, i * 10, 0, i * 10, f.Height))

f.Show()
Application.Run(f)

```

Set a breakpoint at the `DrawLine` statement and start debugging the application, moving the debugger window in order to make the application form visible. If you continue the execution one statement at a time, you can see the lines appear on the form. In this case, the interaction with the graphical system doesn't trigger an event but interacts directly with the `Graphics` object by emitting graphic primitives that are rendered immediately.

This discussion of debugging graphical applications uses examples based on Windows Forms. The same considerations apply to all event systems in which a thread is responsible for event notification. For graphical systems such as WPF, based on the retention of graphic primitives, things work slightly differently, but there are analogous considerations.

## Debugging and Testing with F# Interactive

Functional programming languages have traditionally addressed many debugging and testing issues through their ability to interactively evaluate program statements and print the values of variables, inspecting the program state interactively. *F# Interactive* allows you to execute code fragments and quickly test them; you can also inspect the state of the `fsi` script by querying values from the top level.

Development and testing using *F# Interactive* can effectively reduce development time, because you can evaluate code fragments more than once without having to recompile the entire system. The Visual Studio project system for *F#* makes this process even more productive, because code is edited in the development environment with type checking and IntelliSense; you can send code to *F# Interactive* by selecting it and pressing the `Alt+Enter` shortcut. In this scenario, the `isPalindrome` function from the previous section could have been developed incrementally and tested by invoking it with a test-input argument. After you found and fixed the issue, you could evaluate the function definition again and test it for further bugs.

During software development, it's common practice to write simple programs to test specific features (the "Unit Testing" section discusses this topic more extensively). With *F# Interactive*, you can define tests as functions stored in a file and selectively evaluate them in Visual Studio. This approach can be useful in developing and defining new tests, but you can use more specific tools to run tests in a more systematic way.

## Controlling F# Interactive

As you saw in Chapter 9, programs run in *F# Interactive* have access to an object called `fsi` that lets you control some aspects of the interactive execution. It's contained in the assembly `FSharp.Interactive.Settings.dll`, which is automatically referenced in files ending with `.fsx` and in *F# Interactive* sessions.

Table 19-5 shows some of the methods supported by this object.

*Table 19-5. Members of the fsi object*

Member	Type	Description
<code>fsi.FloatingPointFormat</code>	string	Gets or sets the format used for floating-point numbers, based on .NET Formatting specifications
<code>fsi.FormatProvider</code>	System.IFormat Provider	Gets or sets the cultural format used for numbers, based on .NET Formatting specifications
<code>fsi.PrintWidth</code>	int	Gets or sets the print width used for formatted text output
<code>fsi.PrintDepth</code>	int	Gets or sets the depth of output for tree-structured data
<code>fsi.PrintLength</code>	int	Gets or sets the length of output for lists and other linear data structures
<code>fsi.ShowProperties</code>	bool	Gets or sets a flag indicating whether properties should be printed for displayed values
<code>fsi.ShowDeclarationValues</code>	bool	Gets or sets a flag indicating whether declaration values should be printed
<code>fsi.ShowIEnumerable</code>	bool	Gets or sets a flag indicating whether sequences should be printed in the output of the interactive session
<code>fsi.AddPrinter</code>	('a -> string) -> unit	Adds a printer for values compatible with the specific type 'a
<code>fsi.AddPrintTransformer</code>	('a -> obj) -> unit	Adds a printer that shows any values compatible with the specific type 'a as if they were values returned by the given function
<code>fsi.CommandLineArgs</code>	string[]	Gets the command-line arguments after ignoring the arguments relevant to the interactive environment and replacing the first argument with the name of the last script file

## Some Common F# Interactive Directives

Table 19-6 shows several common directives accepted by F# Interactive, some of which correspond to options for the F# command-line compiler.

*Table 19-6. Some commonly used F# Interactive directives*

Directive	Description
<code>#r path</code>	References a DLL. The DLL is loaded dynamically when first required.
<code>#I path</code>	Adds the given search path to that used to resolve referenced DLLs.
<code>#load file ... file</code>	Loads the given file(s) as if it had been compiled by the F# command-line compiler.
<code>#time</code>	Toggles timing information on/off.
<code>#quit</code>	Exits F# Interactive.



## Understanding How F# Interactive Compiles Code

Although F# Interactive is reminiscent of the read-eval-print loops of interpreted languages, it's substantially different, because it compiles code rather than interprets it. Whenever a code fragment is typed at the top level, it's compiled on the fly as part of a dynamic assembly and evaluated for side effects. This is particularly important for types, because you can create new ones at the top level, and their dependencies may be tricky to understand fully.

Let's start with an example of a nontrivial use of F# Interactive that shows these intricacies. You define the class `APoint`, which represents points using an angle and a radius:

```
type APoint(angle, radius) =
    member x.Angle = angle
    member x.Radius = radius
    new() = APoint(angle = 0.0, radius = 0.0)
```

If you create an instance of the class using F# Interactive, you can inspect the actual type by using the `GetType` method. The output is:

---

```
> let p = APoint();;
val p : APoint

> p.GetType();;
val it : System.Type =
    FSI_0004+APoint
    {Assembly = FSI-ASSEMBLY, Version=0.0.0.0, Culture=neutral, PublicKeyToken=null;
      AssemblyQualifiedName = "FSI_0004+APoint, FSI-ASSEMBLY, Version=0.0.0.0, ...}
```

---

Now, suppose you want to extend the `APoint` class with an additional member that stretches the point radius a given amount; it's natural to type the new definition of the class into the top level and evaluate it. F# Interactive doesn't complain about the redefinition of the type:

```
type APoint(angle, radius) =
    member x.Angle = angle
    member x.Radius = radius
    member x.Stretch (k : double) = APoint(angle = x.Angle, radius = x.Radius + k)
    new() = APoint(angle = 0.0, radius = 0.0)
```

Because you've redefined the structure of `APoint`, you may be tempted to invoke the `stretch` method on it, but doing so results in an error:

---

```
> p.Stretch(22.0);;
error FS0039: The field, constructor or member 'Stretch' is not defined
```

---

To understand what's happening, create a new instance `p2` of the class `APoint` and ask for the type:

---

```
> let p2 = APoint();;
val p2 : APoint

> p2.GetType();;
val it : System.Type =
    FSI_0007+APoint
```

```
{Assembly = FSI-ASSEMBLY, Version=0.0.0.0, Culture=neutral, PublicKeyToken=null;
 AssemblyQualifiedname = "FSI_0007+APoint, FSI-ASSEMBLY, Version=0.0.0.0, ...}
```

---

As you can see, the name of `p2`'s type is `FSI_0005+APoint`, whereas `p`'s type is `FSI_0002+APoint`. Under the hood, F# Interactive compiles types into different modules to ensure that types can be redefined; it also ensures that the most recent definition of a type is used. The older definitions are still available, and their instances aren't affected by the type redefinition.

Understanding the inner mechanisms of F# Interactive is useful when you use it to test F# programs, because interactive evaluation isn't always equivalent to running code compiled using the command-line compiler. On the other hand, the compiled nature of the system guarantees that the code executed by F# Interactive performs as well as compiled code.

## F# Interactive and Visual Studio

The relation between Visual Studio and F# Interactive is different from typical Visual Studio add-ins. It's useful to understand, because the state of an F# Interactive session is separate from the Visual Studio state and can affect the process of testing and debugging in many subtle ways. You can also manage external resources through .NET and COM interfaces, including automating Visual Studio tasks, but accessing its interfaces is less easy than it may appear at first.

F# Interactive is a Visual Studio tool window<sup>2</sup> that lets you interact with an `fsi.exe` process like a standard console. You communicate with the `fsi.exe` process using standard streams. This design choice ensures that a code mistake that causes the F# Interactive to hang doesn't affect the Visual Studio editor that contains the data. You can restart F# Interactive from the tool window and obtain a fresh new instance without having to restart Visual Studio.

Restarting F# Interactive during testing and debugging ensures a clean environment. Consider, for example, a class whose instances open the same file. During a test, the file may be locked by an instance and become inaccessible due to variable redefinition; at some point, the garbage collector runs the finalizer and may close the file, slowing the iterative process of testing with F# Interactive. Sometimes, redefinition causes problems too: a class definition may be evaluated before you make additional changes, and the interface may then behave differently than the one in the program editor; you may continue to evaluate code that refers to the older version. In these cases, restarting F# Interactive is an option, and it returns you to a clean state.

Using Visual Studio automation, you can use F# Interactive to access objects exposing functionalities of the programming environment. The DTE and the DTE2 interfaces are the entry points to the entire Visual Studio object model. For instance, you can print the full path of the active document window:

```
#r @"EnvDTE.dll"
#r @"EnvDTE80.dll"
open System.Runtime.InteropServices
let appObj = Marshal.GetActiveObject("VisualStudio.DTE") :> EnvDTE80.DTE2
printfn "%s" (appObj.ActiveDocument.FullName)
```

You use the `GetActiveObject` method to obtain a reference to the Visual Studio object model, and then you use the .NET assembly containing the interface generated from the COM types to access the object model. In this example, you connect to a running instance of Visual Studio (usually the first one started), not necessarily the same one associated with the F# Interactive executing the code. To attach to a specific instance of Visual Studio, you need to access the COM Running Object Table and associate it with the desired instance.

---

<sup>2</sup>Tool windows in Visual Studio are dockable, like the Solution Explorer window.

Using Visual Studio automation, you can automate several tasks during testing and debugging, including building temporary configurations within Visual Studio for testing purposes. Manipulation of Visual Studio elements isn't restricted to F# projects, but it can affect any area also affected by the macro system.

## Testing Your Code

Anecdotal evidence indicates that functional programming frequently leads to a substantially reduced bug rate for good programmers. This is primarily because programs built using functional techniques tend to be highly compositional, building correct programs out of correct building blocks. The functional programming style avoids or substantially reduces the use of side effects in the program, one property that makes programs more compositional. Debugging and testing, however, are still essential activities to ensure that a program is as close as possible to its specifications. Bugs and misbehaviors are facts of life, and F# programmers must learn techniques to find and remove them.

As a result, software testing is important when you're developing large systems. Tests are initially carried out by writing small programs and interactively running them, but a larger infrastructure quickly becomes necessary as a system grows and as new functionalities must preserve the existing ones. This chapter discusses how you can perform testing with F# using F# Interactive, using the debugging facilities provided by Visual Studio and the .NET infrastructure, and using the NUnit framework for unit testing.

A widely adopted debugging technique is the “do-it-yourself-by-augmenting-your-program-with-printf” approach. This technique suffers from several problems, however; although it's useful, it shouldn't be the only technique you're prepared to apply to the complexities associated with program testing and debugging.

You can use several strategies to test programs and ensure that they behave as expected. The testing theory developed by software engineering has introduced several techniques used every day in software development. This chapter focuses on three aspects of program debugging and testing with F#:

- Using the Visual Studio debugger and the .NET debugging framework
- Using F# Interactive for testing and debugging
- Doing unit testing using NUnit, a freely available framework for unit testing

Alternative tools for debugging and unit testing are available; these include the .NET debugger that ships with the .NET Framework and the testing framework included in some Visual Studio flavors. The concepts behind these tools are similar to those presented here, and the techniques discussed in this chapter can be easily adapted when using them. All these techniques and tools are very helpful, but remember that these are just tools, and you must use them in the appropriate way.

Software testing is an important task in software development; its goal is to ensure that a program or a library behaves according to the system specifications. It's a significant area of software-engineering research, and tools have been developed to support increasing efforts in software verification. Among a large number of testing strategies, unit testing has rapidly become popular because of the software tools used to support this strategy. The core idea behind this approach involves writing small programs to test single features of a system during development. When bugs are found, new unit tests are added to ensure that a particular bug doesn't occur again. Recently, it's been proposed that testing should drive software development, because tests can be used to check new code and later to conduct regression tests, ensuring that new features don't affect existing ones.

---

## FSCHECK

---

Unit testing is not the only strategy for testing; other automatic testing approaches have been investigated and have led to tools implementing them. One of these is FsCheck, available on Codeplex (at <http://fscheck.codeplex.com>), which is a port of Haskell QuickCheck to F# that works with .NET languages such as C#, VB.NET, and, of course, F#. The approach focuses on property verification: a statement in the form of function is checked to find if potential inputs may falsify it.

To give an idea of uses of this tool, we introduce a very simple example taken from the quick start. The property states the simple fact that twice reversing of a list is the list itself:

```
let revPropertyCheck (xs:list<int>) = List.rev(List.rev xs) = xs
```

Using the `Check.Quick` function with the `revPropertyCheck`, FsCheck generates 100 tests and verifies that the property holds for all of them. If, for instance, we change the `revPropertyCheck` function with a test checking, if the reversed list is equal to itself, we get the output:

```
> Check.Quick revPropertyCheck;;
Falsifiable, after 2 tests (2 shrinks) (StdGen (1809913113,295281725)):
[0; 1]
```

FsCheck generates inputs for verifying properties using strategies depending on involved types, and it features the ability to run multiple tests at once and control the number of cases to be generated and tested. With unit tests, the test cases are under control of the unit-test developer; with FsCheck, test cases are generated by the framework with pros and cons: tests may leave particular cases unchecked (this is also holds for programmer-developed unit tests), and the way properties are specified is more declarative, indicating that some property must hold rather testing for specific cases. Combining the two approaches may increase significantly the coverage and effectiveness of tests.

---

This section discusses how you can develop unit tests in F# using the freely available NUnit tool ([www.nunit.com](http://www.nunit.com)). The tool was inspired by JUnit, a unit-testing suite for the Java programming language, but the programming interface has been redesigned to take advantage of the extensible metadata that the CLR provides by means of custom attributes.

Let's start with an example and develop a very simple test suite for the `isPalindrome` function. The first choice you face is whether tests should be embedded in the application. If you create tests as a separated application, you can invoke only the public interface of your software; features internal to the software can't be tested directly. On the other hand, if you embed unit tests in the program, you introduce a dependency from the `nunit.framework.dll` assembly, and the unit tests are available at runtime even where they aren't needed. Because the NUnit approach is based on custom attributes, performance isn't affected in either case. If you use tests during program development, it's more convenient to define them inside the program; in this case, conditional compilation may help to include them only in checked builds.

Listing 19-1 shows a *test fixture* for the `isPalindrome` function—that is, a set of unit tests. Test fixtures are represented by a class annotated with the `TestFixture` custom attribute; tests are instance methods with the signature `unit -> unit` and annotated with the `Test` custom attribute. Inside a test case, you use methods of the `Assert` class to test conditions that must be satisfied during the test. If one of these fails, the entire test is considered a failure, and it's reported to the user by the tool that coordinates test execution.

### *Listing 19-1. A test fixture for the isPalindrome function*

```
open System
open NUnit.Framework
open IsPalindrome
```

```
[<TestFixture>]
type Test() =

    let posTests(strings) =
        for s in strings do
            Assert.That(isPalindrome s, Is.True,
                sprintf "isPalindrome(\"%s\") must return true" s)

    let negTests(strings) =
        for s in strings do
            Assert.That(isPalindrome s, Is.False,
                sprintf "isPalindrome(\"%s\") must return false" s)

[<Test>]
member x.EmptyString () =
    Assert.That(isPalindrome(""), Is.True,
        "isPalindrome must return true on an empty string")

[<Test>]
member x.SingleChar () = posTests ["a"]

[<Test>]
member x.EvenPalindrome () = posTests ["aa"; "abba"; "abaaba"]

[<Test>]
member x.OddPalindrome () = posTests ["aba"; "abbba"; "abababa"]

[<Test>]
member x.WrongString () = negTests ["as"; "F# is wonderful"; "Nice"]
```

*Test units* are methods that invoke objects of the program and test return values to be sure their behavior conforms to the specification. This example also introduces the `posTests` and `negTests` functions used in several tests.

Developing unit tests is a matter of defining types containing the tests. Although you can write a single test for a program, it's a good idea to have many small tests that check various features and different inputs. In this case, you introduce five tests: one for each significant input to the function. You could develop a single test containing all the code used for the individual tests, but, as you see shortly, doing so would reduce the test suite's ability to spot problems in the program. In general, the choice of the test suite's granularity for a program is up to you; it's a matter of finding a reasonable tradeoff between having a large number of unit tests checking very specific conditions and having a small number of unit tests checking broader areas of the program.

To compile the project, you must reference the `nunit.framework.dll` assembly. After the program has been compiled, you can start NUnit and open the executable.

As shown in Figure 19-4, the assembly containing the unit tests is inspected using the CLR's reflection capabilities, classes annotated with the `TestFixture` attribute are identified by NUnit, and searched-for methods are annotated with the `Test` attribute. Initially, all the fixtures and the tests are marked with gray dots. When you run tests, the dot is colored green or red depending on the outcome of the particular test.

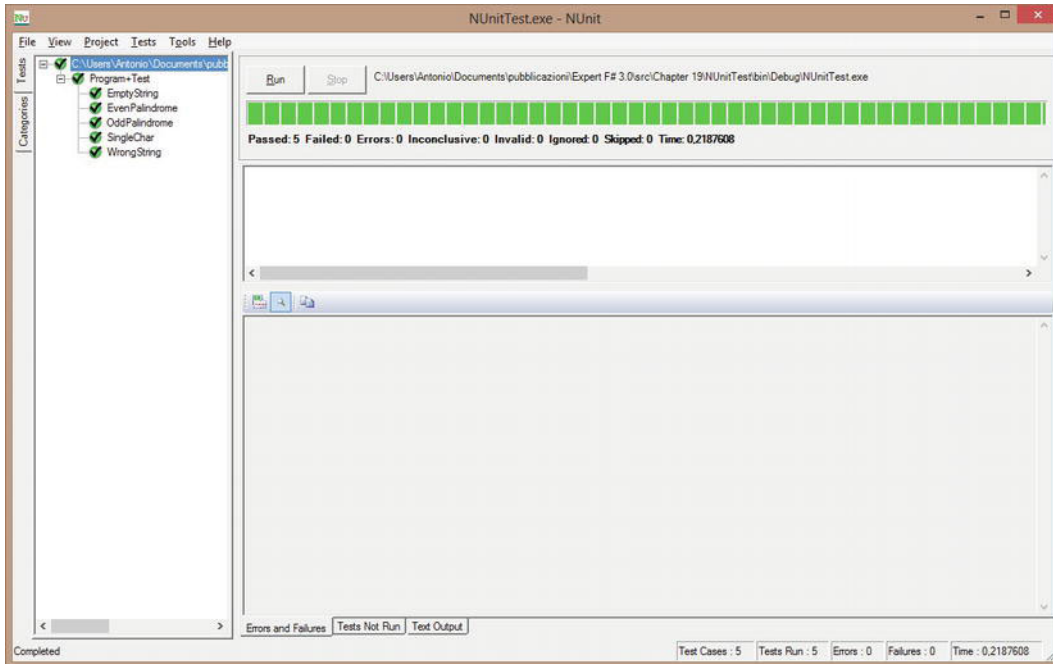

Figure 19-4. Test unit of `isPalindrome` executed in NUnit

If you reintroduce the original bug in the `isPalindrome` function and run NUnit again, `EmptyString` and `EvenPalindrome` fail, the corresponding dots are marked red, and the `Errors` and `Failures` tabs contain details about the test failure. This is the main benefit of having a large number of small unit tests: tools can run them automatically to identify problems in a program as well as the area potentially involved in the problem. Even in this simple example, a single test for the entire function would indicate the problem with the function, although it would fail to spot the kind of input responsible for the issue.

Like every other piece of software, unit tests must be maintained, documented, and updated to follow the evolution of the software for which they're designed. The number of test cases, organized in fixtures, tends to grow with the system during development, and a large system may have thousands of these tests. Tools such as NUnit have features to control tests, and they allow you to run subsets of the entire set of test cases for a system. Test fixtures are a form of grouping; a test suite may contain different test fixtures that may group test cases for different aspects to be tested.

NUnit features a number of additional attributes to support the documentation and classification of test cases and test fixtures. The `Description` attribute lets you associate a description with annotated test fixtures and test cases. You can use the `Category` and `Culture` attributes to associate a category and a culture string with test fixtures and test cases; in addition, to provide more information about tests, NUnit lets you filter tests to be run using the content of the attributes. The ability to select the tests that must be run is important, because running all tests for a system may require a significant amount of time. Other mechanisms to control the execution of tests are offered by the `Ignore` and `Explicit` attributes; you can use the former to disable a test fixture for a period without having to remove all the annotations, and the latter indicates that a test case or a fixture should only be run explicitly.

Another important aspect of testing nontrivial software is the test fixture's life cycle. Test cases are instance methods of a class; and with a simple experiment, you can easily find that NUnit creates an instance of the class and runs all the tests it contains. To verify this, it's enough to define a counter field in the class annotated as a fixture and update its value every time a test is run; the value of the counter is

incremented for each test in the suite. Although you may rely on the standard life cycle of the class, NUnit provides additional annotations to indicate the code that must be run to set up a fixture and the corresponding code to free the resources at the end of the test. You can also define a pair of methods that are run before and after each test case. The `TestFixtureSetUp` and `TestFixtureTearDown` attributes annotate methods to set up and free a fixture; `SetUp` and `TearDown` are the attributes for the corresponding test cases.

Listing 19-2 shows a test fixture for the `isPalindrome` function that includes most of the attributes discussed and one test case.<sup>3</sup> You mark the category of this test case as a “special case.” You also include a description for each test case and the methods invoked before and after the fixture and single-test cases are run. NUnit’s graphical interface includes a tab that reports the output sent to the console; when tests run, the output shows the invocation sequence of the setup and teardown methods.

*Listing 19-2. A Refined Test Fixture for the isPalindrome Function*

```
open System
open NUnit.Framework

[<TestFixture;
 Description("Test fixture for the isPalindrome function")>]
type Test() =
    [<TestFixtureSetUp>]
    member x.InitTestFixture () =
        printfn "Before running Fixture"

    [<TestFixtureTearDown>]
    member x.DoneTestFixture () =
        printfn "After running Fixture"

    [<SetUp>]
    member x.InitTest () =
        printfn "Before running test"

    [<TearDown>]
    member x.DoneTest () =
        Console.WriteLine("After running test")

    [<Test;
     Category("Special case");
     Description("An empty string is palindrome")>]
    member x.EmptyString () =
        Assert.That(isPalindrome(""), Is.True,
                    "isPalindrome must return true on an empty string")
```

The ability to set up resources for test cases may introduce problems during unit testing. In particular, you must treat the setup and teardown methods of test fixtures carefully, because the state shared by different test cases may affect the way they execute. Suppose, for instance, that a file is open during the setup of a fixture. This may save time, because the file is opened only once and not for each test case. If a test case fails and the file is closed, subsequent tests may fail, because they assume that the file has been opened during the fixture’s setup. Nevertheless, in some situations, preloading resources only once for a fixture may save significant time.

<sup>3</sup>To run the example, you must include the definition of the `isPalindrome` function.

NUnit comes with two versions of the tool: one displaying the graphical interface shown in Figure 19-4, and a console version that prints results to the console. Both versions are useful: the windowed application is handy to produce reports about tests and interactively control test processing, and the console version can be used to include the test process in a chain of commands invoked via scripts. Also, other programs can read the tool's output to automate tasks after unit tests. Many command-line arguments are available in the console version to specify all the options available, including test filtering based on categories.

When a unit test fails, you must set up a debugging session to check the application state and the reason for the failure. You can debug tests with the Visual Studio debugger by configuring the Debug tab in the project properties in a similar way, as shown in Figure 19-5. After it's configured, you can set breakpoints in the code and start the debugging session, attach the debugger to `nunit-agent.exe` process, and start the tests. This is important when code development is driven by tests, because new features can be implemented alongside test cases. It's a good way to capitalize on the small test programs that developers frequently write: these small programs become test cases and can be collected without having to develop a new test program each time.

The example shown in Figure 19-5 passes a single argument to `nunit-console.exe`, the assembly containing the tests to be executed. You can also specify an additional argument to filter the tests that

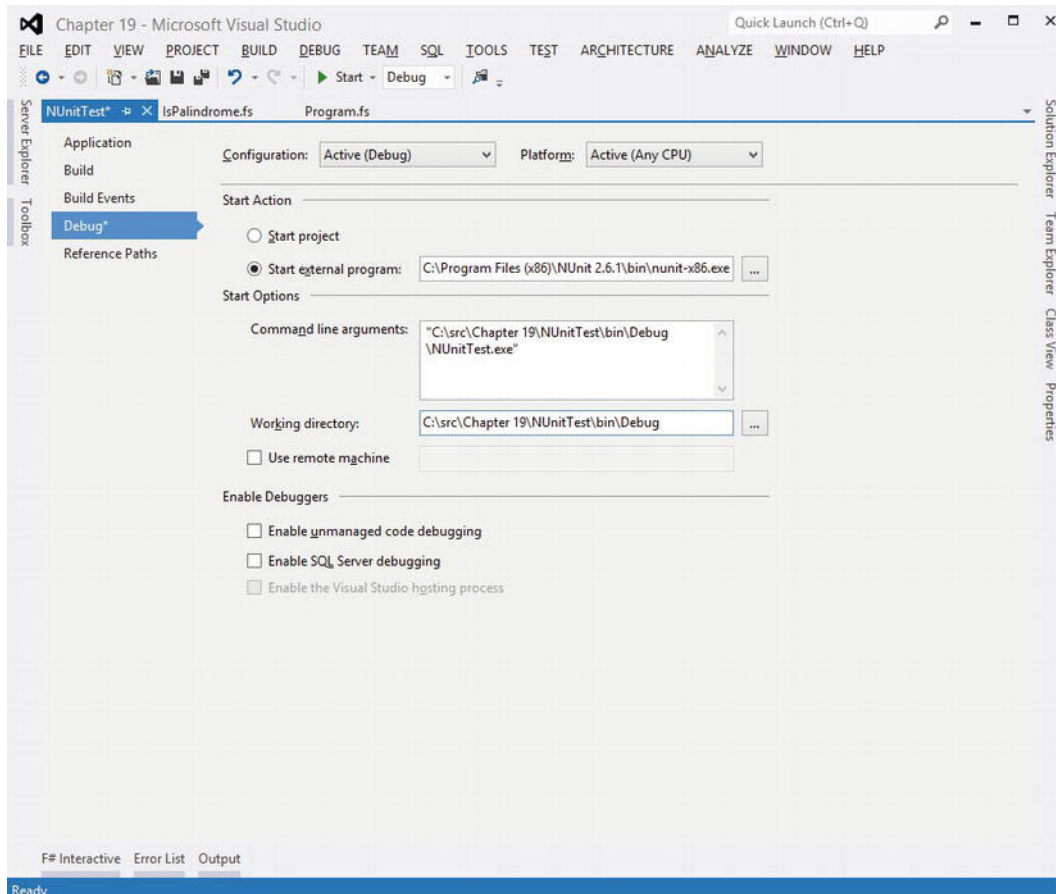

Figure 19-5. Configuring an F# project for debugging NUnit test fixtures



must be run. In this example, if you set a breakpoint in one of the test cases annotated explicitly, the debugger doesn't stop, because by default, these tests are skipped.

---

■ **Note:** This section shows how you can use NUnit to define test cases using F#. NUnit isn't the only tool for unit testing that's available for .NET, however. For example, Visual Studio includes powerful unit-testing tools.

---

## Summary

This chapter introduced techniques and tools you can use to package, debug, and test F# programs, and it also gave an overview of some of the libraries available for use with F# code. Many, many other libraries are available for .NET, and we couldn't possibly cover them in a single book. Many design patterns that you've seen here recur in those libraries; after you get to know the libraries discussed here, you'll find that other libraries are easy to use.

The final chapter covers another set of software engineering issues for F# code: library design in the context of F# and .NET.

## CHAPTER 20



# Designing F# Libraries

This book deals with F#, a language situated in the context of .NET-based software construction and engineering. As an expert F# programmer, you need more than knowledge of the F# language; you also need to use a range of software-engineering tools and methodologies wisely to build software that is truly valuable for the situation for which it's deployed. The previous chapter touched on some important tools. This final chapter looks at some of the methodological issues related to F# library design, including:

- Designing vanilla .NET libraries that minimize the use of F#-specific constructs, according to existing .NET design conventions
- Elements of *functional programming design methodology*, which offers important and deep insights into programming, but doesn't address several important aspects of the library or component design problems
- Specific suggestions for designing .NET and F# libraries, including naming conventions, how to design types and modules, and guidelines for using exceptions

F# is often seen as a functional language, but as this book emphasizes, it's really a multiparadigm language. The OO, functional, imperative, and language-manipulation paradigms are all well supported. That is, F# is a *function-oriented* language, so many of the defaults are set up to encourage functional programming, but programming in the other paradigms is effective and efficient, and a combination is often best of all. Nonetheless, a multiparadigm language brings challenges for library designs and coding conventions.

It's a common misconception that the functional and OO programming methodologies compete; in fact, they're largely orthogonal. It's important to note, however, that functional programming doesn't directly solve many of the practical and prosaic issues associated with library design—for solutions to these problems, you must look elsewhere. In the context of .NET programming, this means turning first to the *.NET Library Design Guidelines*, published online by Microsoft and as a book by Addison-Wesley.

In the official documents, the .NET library design is described in terms of conventions and guidelines for the use of the following constructs in public framework libraries:

- Assemblies, namespaces, and types (see Chapters 6 and 7 of this book)
- Classes and objects, containing properties, methods, and events (see Chapter 6)
- Interfaces (in other words, object interface types; see Chapter 6)
- .NET delegate types (mentioned briefly in Chapters 5 and 6)

- Enumerations (that is, enums from languages such as C#, mentioned briefly in Chapter 6)
- Constants (that is, constant literals from languages such as C#)
- Type parameters (that is, generic parameters; see Chapter 5)

From the perspective of F# programming, you must also consider the following constructs:

- Discriminated union types and their tags (Chapters 3 and 9)
- Record types and their fields (Chapter 3)
- Type abbreviations (Chapter 3)
- Values and functions declared using `let` and `let rec` (Chapter 3)
- Modules (Chapter 6)
- Named arguments (Chapter 6)
- Optional arguments (Chapter 6)

Framework library design is always nontrivial and often underestimated. F# framework and library design methodology is inevitably strongly rooted in the context of .NET OO programming. This chapter gives our opinions about how you can approach library design in the context of F# programming. These opinions are neither proscriptive nor official. More official guidelines may be developed by the F# team and community at some future point, although ultimately the final choices lie with F# programmers and software architects.

---

■ **Note:** Some F# programmers choose to use library and coding conventions much more closely associated with OCaml, Python, or a particular application domain, such as hardware verification. For example, OCaml coding uses underscores in names extensively, a practice avoided by the .NET Framework guidelines but used in places by the F# library. Some also choose to adjust coding conventions to their personal or team tastes.

---

## Designing Vanilla .NET Libraries

One way to approach library design with F# is to design libraries according to the .NET Library Design Guidelines. This implicitly can mean avoiding or minimizing the use of F#-specific or F#-related constructs in the public API. We call these libraries *vanilla .NET libraries*, as opposed to libraries that use F# constructs without restriction and are mostly intended for use by F# applications.

Designing vanilla .NET libraries means adopting the following rules:

- Apply the .NET Library Design Guidelines to the public API of your code. Your internal implementation can use any techniques you want.
- Restrict the constructs you use in your public APIs to those that are most easily used and recognized by .NET programmers. This means avoiding the use of some F# idioms in the public API.
- Use the Microsoft FxCop quality-assurance tool to check the public interface of your assembly for compliance. Use FxCop exemptions where you deem necessary.

At the time of writing, here are some specific recommendations from the authors of this book:

- Avoid using F# list types 'T list in vanilla .NET APIs. Use seq<'T> (i.e. IEnumerable<'T>) or arrays instead of lists.
- Avoid using F# function types in vanilla .NET APIs. F# function values tend to be a little difficult to create from other .NET languages. Instead, consider using .NET delegate types, such as the overloaded System.Func<...> types available from .NET 3.5 onward.
- Avoid using F#-specific language constructs, such as discriminated unions and optional arguments, in vanilla .NET APIs.

For example, consider the code in Listing 20-1, which shows some F# code that you intend to adjust to be suitable for use as part of a .NET API.

*Listing 20-1. An F# Type Prior to Adjustment for Use as Part of a Vanilla .NET API*

```
namespace global

open System

type APoint(angle, radius) =
    member x.Angle = angle
    member x.Radius = radius
    member x.Stretch(l) = APoint(angle = x.Angle, radius = x.Radius * l)
    member x.Warp(f) = APoint(angle = f(x.Angle), radius = x.Radius)

    static member Circle(n) =
        [ for i in 1..n -> APoint(angle = 2.0 * Math.PI / float(n), radius = 1.0) ]

    new() = APoint(angle = 0.0, radius = 0.0)
```

The inferred F# type of this class is:

---

```
type APoint =
    class
        new : unit -> APoint
        new : angle:float * radius:float -> APoint
        member Stretch : l:float -> APoint
        member Warp : f:(float -> float) -> APoint
        member Angle : float
        member Radius : float
        static member Circle : n:int -> APoint list
    end
```

---

Let's look at how this F# type appears to a programmer using C# or another .NET library. The approximate C# signature is:

---

```
// C# signature for the unadjusted APoint class of Listing 20-1
```

```
[Serializable]
public class APoint
```

```

{
    public APoint();
    public APoint(double angle, double radius);

    public double Angle { get; }
    public double Radius { get; }

    public static Microsoft.FSharp.Collections.FSharpList<APoint> Circle(int n);
    public APoint Stretch(double l);
    public APoint Warp(Microsoft.FSharp.Core.FSharpFunc<double, double> f);
}

```

---

There are some important points to notice about how F# has chosen to represent constructs here. For example:

- Metadata, such as argument names, has been preserved.
- F# methods that take tupled arguments become C# methods that take multiple arguments.
- Functions and lists become references to corresponding types in the F# library.

The full rules for how F# types, modules, and members are represented in the .NET Common Intermediary Language are explained in the F# language reference on the F# web site.

To make a .NET component, place it in a file `component.fs` and compile this code into a strong-name signed DLL using the techniques from Chapter 7:

---

```

C:\fsharp> sn -k component.snk
C:\fsharp> fsc --target:library --keyfile:component.snk component.fs

```

---

Figure 20-1 shows the results of applying the Microsoft FxCop tool to check this assembly for compliance with the .NET Framework Design Guidelines. This reveals a number of problems with the assembly. For example, the .NET Framework Design Guidelines require:

- Types must be placed in namespaces.
- Public identifiers must be spelled correctly.
- Additional attributes must be added to assemblies related to .NET Security and Common Language Specification (CLS) compliance.

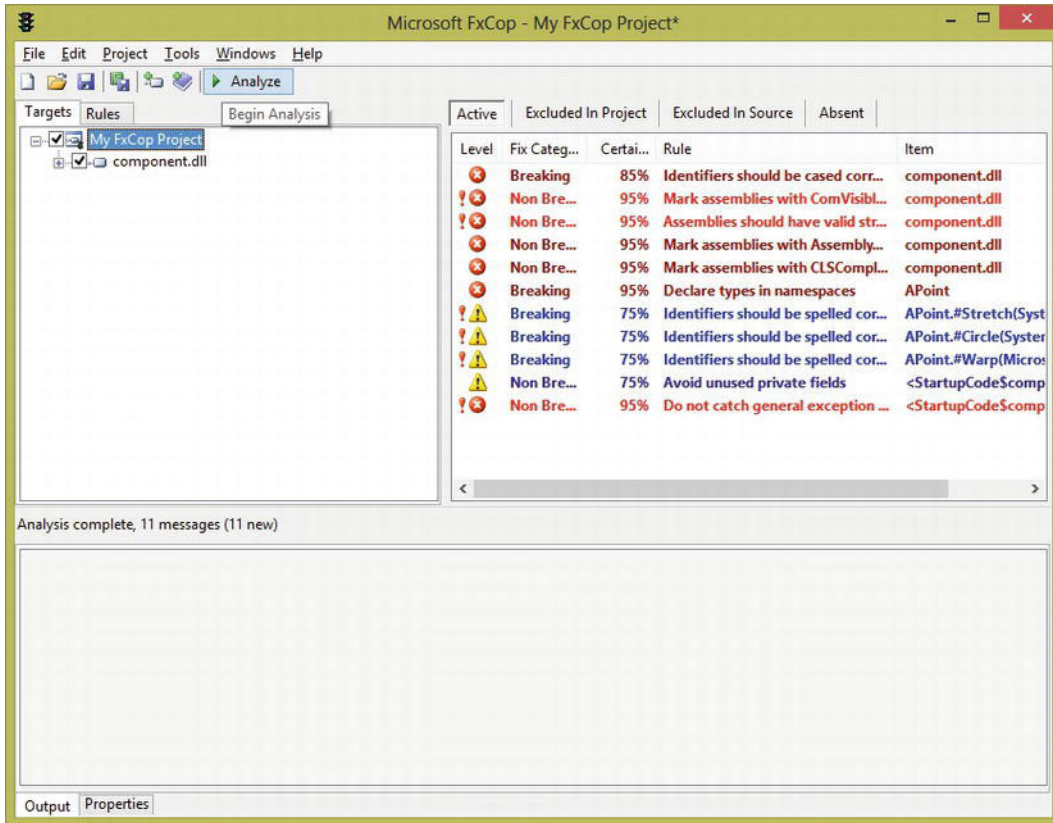

Figure 20-1. Running FxCop on the code from Listing 20-1

Listing 20-2 shows how to adjust this code to take these things into account.

**Listing 20-2.** An F# Type After Adjustment for Use As Part of a Vanilla.NET API

```
namespace ExpertFSharp.Types
```

```
open System
```

```
module AssemblyAttributes =
    [<assembly : System.Runtime.InteropServices.ComVisible(false);
     assembly : System.CLSCompliant(true)>]
    do()
```

```
type RadialPoint(angle, radius) =
    member x.Angle = angle
    member x.Radius = radius
    member x.Stretch(factor) = RadialPoint(angle = x.Angle, radius = x.Radius * factor)
    member x.Warp(transform : Converter<_, _>) =
        RadialPoint(angle = transform.Invoke(x.Angle), radius = x.Radius)
    static member Circle(count) =
```

```

    seq { for i in 1..count ->
          RadialPoint(angle = 2.0 * Math.PI / float(count), radius = 1.0)}
new() = RadialPoint(angle = 0.0, radius = 0.0)

```

The inferred F# type of the code in Listing 20-2 is:

---

```

type RadialPoint =
  class
    new : unit -> RadialPoint
    new : angle:float * radius:float -> RadialPoint
    member Stretch : factor:float -> RadialPoint
    member Warp : transform:System.Converter<float,float> -> RadialPoint
    member Angle : float
    member Radius : float
    static member Circle : count:int -> seq<RadialPoint>
  end

```

---

The C# signature is now:

---

```

// C# signature for the unadjusted RadialPoint class of Listing 20-2
[Serializable]
public class RadialPoint
{
    public RadialPoint();
    public RadialPoint(double angle, double radius);

    public double Angle { get; }
    public double Radius { get; }

    public static IEnumerable<RadialPoint> Circle(int count);
    public RadialPoint Stretch(double factor);
    public RadialPoint Warp(Converter<double, double> transform);
}

```

---

The fixes you make to prepare this type for use as part of a vanilla .NET library are:

- Add several attributes as directed by the FxCop tool. You can find the meaning of these attributes in the MSDN documentation referenced by the FxCop warning messages.
- Adjust several names: APoint, n, l, and f to become RadialPoint, count, factor, and transform, respectively.
- Use a return type of seq<RadialPoint> instead of RadialPoint list by changing a list construction using [ ... ] to a sequence construction using seq { ... }. An alternative option would be to use an explicit upcast ([ ... ] :> seq<\_>).
- Use the .NET delegate type System.Converter instead of an F# function type.

After applying these, the last remaining FxCop warning tells you that namespaces with two to three types aren't recommended.

The last two previous points aren't essential, but, as mentioned, delegate types and sequence types tend to be easier for C# programmers to use than F# function and list types (F# function types aren't compiled to .NET delegate types, partly for performance reasons). Note that you can use FxCop exemptions to opt out of any of the FxCop rules, either by adding an exemption entry to FxCop itself or by attaching attributes to your source code.

---

■ **Tip:** If you're designing libraries for use from any .NET language, there's no substitute for actually doing some experimental C# and Visual Basic programming to ensure that uses of your libraries look good from these languages. You can also use tools such as .NET Reflector and the Visual Studio Object Browser to ensure that libraries and their documentation appear as expected to developers. If necessary, enlist the help of a C# programmer and ask her what she thinks.

---

## Understanding Functional Design Methodology

So far, this chapter has looked at how to do vanilla .NET library design with F#. Frequently, however, F# programmers design libraries that are free to make more sophisticated use of F#, and they more or less assume that client users are using F# as well. To make the best use of F# in this situation, it's helpful to use functional programming design techniques as part of the library design process. For this reason, this section covers what functional programming brings to the table with regard to design methodology.

## Understanding Where Functional Programming Comes From

Let's recap the origins of the major programming paradigms from a design perspective:

- *Procedural programming* arises from the fundamentally imperative nature of processing devices: microprocessors are state machines that manipulate data using side effects.
- *Object-oriented programming* arises from the need to encapsulate and reuse large objects and associated behaviors, such as those used for GUI applications.
- *Functional programming* differs in that it arises from one view of the *mathematics* of computation. That is, functional programming, in its purest form, is a way of describing computations using constructs that have useful mathematical properties, independent of their implementations.

For example, the functional programming design methodology places great importance on constructs that are *compositional*. For example, in F#, you can map a function over a list of lists as:

```
let map2 f inp = List.map (List.map f) inp
```

This is a simple example of the inherent compositionality of generic functions: the expression `List.map f` produces a new function that can in turn be used as the argument to `List.map`. Understanding compositionality is the key to understanding much of what goes by the name of functional programming. For example, functional programmers aren't interested in a lack of side effects just for the sake of it—



instead, they like programs that don't use side effects, because such programs tend to be more compositional than those that do.

Functional programming often goes further by emphasizing *transformations that preserve behavior*. For example, you expect to be able to make the following refactorings to your code regardless of the function `f` or of the values `inp`, `x`, or `rest`:

```
List.hd (x :: rest) > x
```

```
List.concat (List.map (List.filter f) inp) > List.filter f (List.concat inp)
```

Equations such as these can be a source of useful documentation and test cases, and in some situations, they can even be used to specify entire programs. Furthermore, good programmers routinely manipulate and optimize programs in ways that effectively assume these transformations are valid. If these transformations are *not* valid, it's easy to accidentally insert bugs when you're working with code. That said, many important transformation equations aren't guaranteed to *always* be valid—they typically hold only if additional assumptions are made. As in the first example, the expression `rest` shouldn't have side effects.

Transformational reasoning works well for some kinds of code and badly for others. Table 20-1 lists some of the F# and .NET constructs that are highly compositional and for which transformational reasoning tends to work well in practice.

**Table 20-1.** Some Compositional F# Library Constructs Amenable to Equational Reasoning

Constructs	Examples	Explanation
Base types	<code>int</code> , <code>float</code>	Code using immutable basic types is often relatively easy to reason about. There are some exceptions to the rule: the presence of NaN values and approximations in floating-point operations can make it difficult to reason about floating-point code.
Collections	<code>Set&lt;'T&gt;</code> , <code>Map&lt;'Key, 'Value&gt;</code>	Immutable collection types are highly amenable to equational reasoning. For example, you expect equations such as <code>Set.union Set.empty x = x</code> to hold.
Control types	<code>Lazy&lt;'T&gt;</code> , <code>Async&lt;'T&gt;</code>	Control constructs are often highly compositional and have operators that allow you to combine them in interesting ways. For example, you expect equations such as <code>(lazy x).Force() = x</code> to hold.
Data abstractions	<code>seq&lt;'T&gt;</code>	F# sequences aren't pure values, because they may access data stores using major side effects, such as network I/O. In practice, uses of sequences tend to be very amenable to equational reasoning. This assumes that the side effects for each iteration of the sequence are isolated and independent.

## Understanding Functional Design Methodology

Functional design methodology is rooted in compositionality and reasoning. In practice, it's largely about these steps:

1. Deciding what values you're interested in representing. These values may range from simple integers to more sophisticated objects, such as expression trees, from Chapter 9, or the asynchronous tasks from Chapter 13.
2. Deciding what operations are required to build these values, extracting information from them, and combining them and transforming them.
3. Deciding what equations and other algebraic properties should hold between these values, and assessing whether these properties hold for the implementation.

Steps 1 and 2 explain why functional programmers often prefer to define operations separately from types. As a result, functional programmers often find OO programming strange, because it emphasizes operations on *single* values, whereas functional programming emphasizes operations that *combine* values. This carries over to library implementation in functional programming, in which you often see types defined first and then modules containing operations on those types.

Because of this, one pattern that is common in the F# library is:

- The type is defined first.
- Then, a module defines the functions to work over the type.
- Finally, a with augmentation adds the most common functions as members. Chapter 6 describes augmentations.

One simple example of functional programming methodology in this book appears in Chapter 12, where you saw how a representation for propositional logic is defined using a type:

```
type Var = string

type Prop =
    | And of Prop * Prop
    | Var of Var
    | Not of Prop
    | Exists of Var * Prop
    | False
```

Operations were then defined to combine and analyze values of type Prop. It wouldn't make sense to define all of these operations as intrinsic to the Prop type, an approach often taken in OO design. In that same chapter, you saw another representation of propositional logic formulae where two logically identical formulae were normalized to the same representations. This is an example of step 3 of the functional design methodology: the process of designing a type involves specifying the equations that should hold for values of that type.

You've seen many examples in this book of how OO programming and functional programming can work well together. For example, F# objects are often immutable, but use OO features to group together some functionality working on the same data. Also, F# object interface types are often used as a convenient notation for collections of functions.

However, some tensions exist between functional programming and OO design methodology. For example, when you define operations independently of data (that is, the functional style), it's simple to add a new operation, but modifying the type is more difficult. In OO programming using abstract and virtual methods, it's easy to add a new inherited type, but adding new operations (that is, new virtual methods) is difficult.

Similarly, functional programming emphasizes *simple but compositional* types: for example, functions and tuples. OO programming tends to involve creating many (often large and complex) types with

considerable amounts of additional metadata. These are often less compositional, but sometimes, more self-documenting.

Finally, although functional programming doesn't provide a complete software design methodology, it's beautiful and powerful when it works, creating constructs that can be welded with amazing expressivity and a low bug rate. However, not all constructs in software design are amenable to compositional descriptions and implementations, and an over-reliance on pure programming can leave you bewildered and abandoned when the paradigm doesn't offer useful solutions that scale in practice. This is the primary reason why F# is a multiparadigm language: to ensure that functional techniques can be combined with other techniques where appropriate.

---

■ **Note** Some functional languages such as Haskell place strong emphasis on equational reasoning principles. In F#, equational reasoning is slightly less important; however, it still forms an essential part of understanding what functional programming brings to the arena of design methodology.

---

## Applying the .NET Library Design Guidelines to F#

This section presents some additional recommendations for applying the .NET Library Design Guidelines to F# programming. We do this by making a series of recommendations that can be read as extensions to these guidelines.

### Recommendation: Use the .NET Naming and Capitalization Conventions Where Possible

Table 20-2 summarizes the .NET guidelines for naming and capitalization in code. We've added our own recommendations for how these should be adjusted for some F# constructs. This table refers to the following categories of names:

- *PascalCase*: LeftButton and TopRight, for example
- *camelCase*: leftButton and topRight, for example
- *Verb*: A verb or verb phrase; performAction or SetValue, for example
- *Noun*: A noun or noun phrase; cost or ValueAfterDepreciation, for example
- *Adjective*: An adjective or adjectival phrase; Comparable or Disposable, for example

In general, the .NET guidelines strongly discourage the use of abbreviations (for example, “use OnButtonClick rather than OnBtnClick”). Common abbreviations such as Async for Asynchronous are tolerated. This guideline has historically been broken by functional programming; for example, List.iter uses an abbreviation for iterate. For this reason, using abbreviations tends to be tolerated to a greater degree in F# programming, although we discourage using additional abbreviations beyond those found in existing F# libraries.

Acronyms such as XML aren't abbreviations and are widely used in .NET libraries, although in uncapitalized form (Xml). Only well-known, widely recognized acronyms should be used.

The .NET guidelines say that casing can't be used to avoid name collisions and that you must assume some client languages are case insensitive. For example, Visual Basic is case insensitive.

**Table 20-2.** Conventions Associated with Public Constructs in .NET Frameworks and Author-Recommended Extensions for F# Constructs

Construct	Case	Part	Examples	Notes
Concrete types	PascalCase	Noun/ adjective	List, DoubleComplex	Concrete types are structs, classes, enumerations, delegates, records, and unions. Type names are traditionally lowercase in OCaml, and F# code has generally followed this pattern. However, as F# matures as a language, it's moving much more to follow standardized .NET idioms.
DLLs	PascalCase		Microsoft.FSharp. Core.dll  <Company>. <Component>.dll	
Union tags	PascalCase	Noun	Some, Add, Success	Don't use a prefix in public APIs. Optionally use a prefix when internal, such as type Teams = TAlpha   TBeta   TDelta.
Event	PascalCase	Verb	ValueChanged	
Exceptions	PascalCase		WebException	
Field	PascalCase	Noun	CurrentName	
Interface types	PascalCase	Noun/ adjective	IDisposable	
Method	PascalCase	Verb	ToString	
Namespace	PascalCase		Microsoft.FSharp. Core	Generally use <Organization>.<Technology>[.<Subnamespace>], but drop the organization if the technology is independent of organization.
Parameters	camelCase	Noun	typeName, transform, range	
let values (internal)	camelCase	Noun/ verb	getValue, myTable	
let values (external)	camelCase or PascalCase	Noun	List.map, Dates. Today	let-bound values are often public when following traditional functional design patterns. However, generally use PascalCase when the identifier can be used from other .NET languages.
Property	PascalCase	Noun/ adjective	IsEndOfFile, BackColor	Boolean properties generally use Is and Can and should be affirmative, as in IsEndOfFile, not IsNotEndOfFile.
Type parameters	Any	Noun/ adjective	'T, 't, 'Key, 'Value	

We generally recommend using lowercase for variable names, unless you're designing a library:

- `let x = 1`
- `let now = System.DateTime.Now`

We recommend using lowercase for all variable names bound in pattern matches, function definitions, and anonymous inner functions. Functions may also use uppercase:

- `let add I J = I + J`
- `let add i j = i + j`

Use uppercase when the natural convention is to do so, as in the case of matrices, proper nouns, and common abbreviations such as `I` for the identity function:

- `let f (A: matrix) (B: matrix) = A + B`
- `let Monday = 1`
- `let I x = x`

We recommend using camelCase for other values, including:

- Ad hoc functions in scripts
  - Values making up the internal implementation of a module
  - Locally bound values in functions
- `let emailMyBossTheLatestResults = ...`
  - `let doSomething () =`  
`let firstResult = ...`  
`let secondResult = ...`

## Recommendation: Avoid Using Underscores in Names

In some older F# code, you see the frequent use of underscores to qualify some names. For example:

- Suffixes such as `_left` and `_right`
- Prefix verbs such as `add_`, `remove_`, `try_`, and `is_`, `do_`
- Prefix connectives such as `to_`, `of_`, `from_`, and `for_`

We recommend avoiding this style because it clashes with .NET naming conventions.

---

**■ Note** No rules are hard and fast. Some F# programmers ignore this advice and use underscores heavily, partly because functional programmers often dislike extensive capitalization. Furthermore, OCaml code uses underscores everywhere. But be aware that the style is often disliked by others who have a choice about whether to use it. It has the advantage that abbreviations can be used in identifiers without them being run together.

---

## Recommendation: Follow the .NET Guidelines for Exceptions

The .NET Framework Design Guidelines give good advice about the use of exceptions in the context of all .NET programming. Some of these guidelines are as follows:

- Don't return error codes. Exceptions are the main way of reporting errors in frameworks.
- Don't use exceptions for normal flow of control. Although this technique is often used in languages such as OCaml, it's bug-prone and slow on .NET. Instead, consider returning a `None` option value to indicate failure.
- Document all exceptions thrown by your code when a function is used incorrectly.
- Where possible, throw existing exceptions in the `System` namespaces.
- Use `InvalidOperationException` and `ArgumentException` to throw exceptions where possible

---

■ **Note** Other exception-related topics covered by the .NET guidelines include advice on designing custom exceptions, wrapping exceptions, choosing exception messages, and special exceptions to avoid throwing (`OutOfMemoryException`, `ExecutionEngineException`, `COMException`, `SEHException`, `StackOverflowException`, `NullReferenceException`, `AccessViolationException`, and `InvalidCastException`).

---

## Recommendation: Consider Using Option Values for Return Types Instead of Raising Exceptions

The .NET approach to exceptions is that they should be exceptional. That is, they should occur relatively infrequently. However, some operations (for example, searching a table) may fail frequently. F# option values are an excellent way to represent the return types of these operations.

## Recommendation: Follow the .NET Guidelines for Value Types

The .NET guidelines give good guidance about when to use .NET value types (that is, structs, introduced in Chapter 6). In particular, they recommend using a struct in a public API only when the following are all true:

- A type logically represents a single value similar to a primitive type.
- It has an instance size smaller than 16 bytes.
- It's immutable.
- It won't have to be boxed frequently (that is, converted to/from the type `System.Object`).

Some programmers are much stricter and almost never use structs in public APIs.

## Recommendation: Consider Using Explicit Signature Files for Your Framework

Chapter 7 describes explicit signature files. Using explicit signatures files for framework code ensures that you know the full public surface of your API and can cleanly separate public documentation from internal implementation details.

## Recommendation: Consider Avoiding the Use of Implementation Inheritance for Extensibility

Chapter 6 describes implementation inheritance. In general, the .NET guidelines are agnostic with regard to the use of implementation inheritance. In F#, implementation inheritance is used more rarely than in other .NET languages. The main rationale for this is given in Chapter 6, which also presents many alternative techniques for designing and implementing OO types using F#. However, implementation inheritance is used heavily in GUI frameworks.

---

■ **Note** Other OO extensibility topics discussed in the .NET guidelines include events and callbacks, virtual members, abstract types and inheritance, and limiting extensibility by sealing classes.

---

## Recommendation: Use Properties and Methods for Attributes and Operations Essential to a Type

Here's an example:

- type HardwareDevice with
  - ...
    - member ID: string
    - member SupportedProtocols: seq<Protocol>

Consider using methods for the intrinsic operations essential to a type:

- type HashTable<'Key, 'Value> *with*
  - ...
    - member Add : 'Key \* 'Value -> unit
    - member ContainsKey : 'Key -> bool
    - member ContainsValue : 'Value -> bool

Consider using static methods to hold a Create function instead of revealing object constructors:

- type HashTable<'Key, 'Value> with
  - static member Create : IHashProvider<'Key> -> HashTable<'Key, 'Value>

## Recommendation: Avoid Revealing Concrete Data Representations Such as Records

Where possible, avoid revealing concrete representations such as records, fields, and implementation inheritance hierarchies in framework APIs.

The rationale is that one of the overriding aims of library design is to avoid revealing concrete representations of objects, for the obvious reason that you may want to change the implementation later. For example, the concrete representation of `System.DateTime` values isn't revealed by the external, public API of the .NET library design. At runtime, the Common Language Runtime knows the committed implementation that will be used throughout execution. However, compiled code doesn't pick up dependencies on the concrete representation.

## Recommendation: Use Active Patterns to Hide the Implementations of Discriminated Unions

Where possible, avoid using large discriminated unions in framework APIs, especially if you expect there is a chance that the representation of information in the discriminated union will undergo revision and change. For frameworks, you should typically hide the type or use active patterns to reveal the ability to pattern match over language constructs. Chapter 9 describes active patterns.

This doesn't apply to the use of discriminated unions internal to an assembly or to an application. Likewise, it doesn't apply if the only likely future change is the addition of further cases, and you're willing to require that client code be revised for these cases. Finally, active patterns can incur a performance overhead, and this should be measured and tested, although their benefits frequently outweigh this cost.

---

■ **Note** Using large, volatile discriminated unions freely in APIs encourages people to use pattern-matching against these discriminated union values. This is appropriate for unions that don't change. However, if you reveal discriminated unions indiscriminately, you may find it very hard to version your library without breaking user code.

---

## Recommendation: Use Object Interface Types Instead of Tuples or Records of Functions

In Chapter 5, you saw various ways to represent a dictionary of operations explicitly, such as using tuples of functions or records of functions. In general, we recommend that you use object interface types for this purpose, because the syntax associated with implementing them is generally more convenient.

## Recommendation: Understand When Currying Is Useful in Functional Programming APIs

*Currying* is the name used when functions take arguments in the iterated form—that is, when the functions can be partially applied. For example, the following function is curried:

```
let f x y z = x + y + z
```

This isn't curried:



```
let f (x, y, z) = x + y + z
```

Here are some of our guidelines for when to use currying and when not to use it:

- Use currying freely for rapid prototyping and scripting. Saving keystrokes can be very useful in these situations.
- Use currying when partial application of the function is highly likely to give a useful residual function (see Chapter 3).
- Use currying when partial application of the function is necessary to permit useful precomputation (see Chapter 8).
- Avoid using currying in vanilla .NET APIs or APIs to be used from other .NET languages.

When using currying, place arguments in order from the least varying to the most varying. Doing so makes partial application of the function more useful and leads to more compact code. For example, `List.map` is curried with the function argument first because a typical program usually applies `List.map` to a handful of known function values but many different concrete list values. Likewise, you saw in Chapters 8 and 9 how recursive functions can be used to traverse tree structures. These traversals often carry an environment. The environment changes relatively rarely—only when you traverse the subtrees of structures that bind variables. For this reason, the environment is the first argument.

When you use currying, consider the importance of the pipelining operator; for example, place function arguments first and object arguments last.

F# also uses currying for `let`-bound binary operators and combinators:

- `let divmod n m = ...`
- `let map f x = ...`
- `let fold f z x = ...`

However, see Chapters 6 and 8 for how to define operators as static members in types, which aren't curried.

## Recommendation: Use Tuples for Return Values, Arguments, and Intermediate Values

Here is an example of using a tuple in a return type:

- `val divmod : n:int -> m:int -> int * int`

## Some Recommended Coding Idioms

This section looks at a small number of recommendations for writing implementation code, as opposed to library designs. We don't give many recommendations on formatting, because formatting code is relatively simple for #light indentation-aware code. We do make a couple of formatting recommendations that early readers of this book asked about.

## Recommendation: Use the Standard Operators

The following operators are defined in the F# standard library and should be used wherever possible instead of defining equivalents. Using these operators tends to make code much easier to read, so we strongly recommend it. This is spelled out explicitly because other languages similar to F# don't support all of these operators, and thus some F# programmers aren't aware that these operators exist:

```
f >> g  -- forward composition
g << f  -- reverse composition
x |> f  -- forward pipeline
f <| x  -- reverse pipeline

x |> ignore  -- throwing away a value

x + y  -- overloaded addition (including string concatenation)
x - y  -- overloaded subtraction
x * y  -- overloaded multiplication
x / y  -- overloaded division
x % y  -- overloaded modulus

x <<< y  -- bitwise left shift
x >>> y  -- bitwise right shift
x ||| y  -- bitwise or, also for working with enumeration flags
x &&& y  -- bitwise and, also for working with enumeration flags
x ^^ y  -- bitwise exclusive or, also for working with enumeration flags

x && y  -- lazy/short-circuit and
x || y  -- lazy/short-circuit or
```

## Recommendation: Place the Pipeline Operator |> at the Start of a Line

People often ask how to format pipelines. We recommend this style:

```
let methods =
    System.AppDomain.CurrentDomain.GetAssemblies()
    |> List.ofArray
    |> List.map (fun assem -> assem.GetTypes())
    |> Array.concat
```

## Recommendation: Format Object Expressions Using the member Syntax

People often ask how to format object expressions. We recommend this style:

```
open System

[<AbstractClass>]
```

```
type Organization() =
    abstract member Chief : string
    abstract member Underlings : string list

let thePlayers = {
    new Organization() with
        member x.Chief = "Peter Quince"
        member x.Underlings =
            ["Francis Flute"; "Robin Starveling"; "Tom Snout"; "Snug"; "Nick Bottom"]
    interface IDisposable with
        member x.Dispose() = ()}
```

---

■ **Note** The discussion of F# design and engineering issues in Chapters 18 and 19 is necessarily limited. In particular, we haven't covered topics such as aspect-oriented programming, design and modeling methodologies, software quality assurance, or software metrics, all of which are outside the scope of this book.

---

## Summary

This chapter covered some of the rules you may apply to library design in F#, particularly taking into account the idioms and traditions of .NET. It also considered some of the elements of the functional programming design methodology, which offers many important and deep insights. Finally, we gave some specific suggestions for use when you're designing .NET and F# libraries.

That concludes our tour of F#. We hope you enjoy a long and productive career working with the language.



# Index

## A

- Abstract keyword, 127
- Abstract members, 135
- Abstract syntax implementations, 214–216
- Abstract syntax representations
  - caching properties, 208
  - flatten, 204–205
  - mapping transformation, 205–206
  - memoizing construction, 208–210
  - pros and cons, 204
  - syntax type design, 204
  - using on-demand computation, 206–207
- Abstract syntax trees (ASTs), 178
  - drawing namespace, 178
  - extractScenes, 179–180
  - inferred types, 179
  - XML conversion, 178–179
- Accumulating and rewriting transformations, 205
- Accumulating functions, 47
- Accumulating parameter, 224
- Action.Login, 371
- Activation records, 515
- Active patterns, 174
  - converting same data to many views, 211–213
  - hiding abstract syntax implementations, 214–216
  - matching on .NET object types, 213–214
  - .NET Library Design Guidelines and, 579
  - partial and parameterized active patterns, 214
- adb.exe, 419
- ADO.NET, 347–351
- agent.Post(message), 286
- agent.Receive(?timeout), 286
- Agents. See MailboxProcessor
- agent.Scan(scanner, ?timeout), 286
- agent.TryReceive(?timeout), 286
- agent.TryScan(scanner, ?timeout), 286
- Aggregate operators, 191–192
- Anchoring control, 432
- Application store, 391–392
- Arithmetic expressions, error estimation , 499–501
- Arithmetic operators, 234
- Array2D module, 59
- ASCII character encoding, 175
- AsyncAccept, 279
- AsyncAcquire method, 290
- Async.AwaitTask(task), 278, 280
- Async.Catch combinator, 281
- AsyncExecuteReader, 279
- AsyncExecuteXmlReader, 279
- Async.FromBeginEnd(beginAction, endAction), 278
- Async.FromContinuations(callback), 278
- AsyncGetResponse, 279
- Asynchronous and parallel computations
  - Async type methods, 278–279
  - cancellation checking, 274
  - common constructs used, 274, 275
  - common I/O operations, 279
  - exception propagation, 273–274
  - exceptions and cancellation, 280–281
  - fetching multiple Web pages, 270–272
  - fork-join parallel operator implementation, 281
  - in CPU parallelism, 282
  - parallel file processing
    - asynchronous image processor, 276–278
    - primitives and combinators, 278
    - synchronous image processor, 275–276
  - resource lifetime management, 274
  - thread hopping, 272–273

- Asynchronous and parallel computations (*cont.*)
  - using tasks, 280
- Asynchronous programs, 258
- Asynchronous Web crawling, 287–290
- Async.Parallel(computations), 278
- AsyncRead, 279
- AsyncReceive, 279
- Async.RunSynchronously(async), 278
- AsyncSend, 279
- Async.StartAsTask(computation), 280
- Async.Start(async), 278
- Async.StartChild(async), 279
- Async.StartImmediate(async), 279
- AsyncWrite, 279
- AsyncExecuteNonQuery, 279
- Attribute types
  - custom attributes and, 495, 496
  - .NET types, 100
- Automatic generalization, 45
- Automatic memory, 514
- AxisColor property, 445
- AxShockwaveFlashObjects, 520

## B

- Background Workers
  - building iterative worker, 264–267
  - GUI connection, 268–270
  - primary object members, 262, 263
  - raising GUI-thread events, 267–268
  - simple use of, 262–263
  - two-faced object, 263
- Berkeley Database (BDB), 534
- bigint type, 234
- Binary comparison operators, 27
- Binary data, 176
- Binary decision diagrams (BDD), 296
  - circuit verification, 307
  - Equiv, 306
  - implementation, 304–306
  - language representation techniques, 304
  - logical rules, 306
  - mkAnd operation, 306
  - pretty-printer installation, 306–307
  - Prop representation, 306, 307
  - ToString member, 306
- Binary operators, 46
- BinaryReader, 68
- Binary serialization, 92–94
- BinaryWriter, 67
- Binary XAML (BXAML), 468

- Bitwise operations, 236–237
- Boolean-valued expression, 28
- Bool type, 233
- Bottom-up rewriting, 205
- box function, 91–92
  - binary serialization, 92, 93
  - .NET types, 99
- builder, for workflows, 478, 483–485, 488
- byte
  - literal byte arrays and, 164
  - operator, 235

## C

- C5 collection library, 509
- Callbacks model, 46
- Cancellation checking, 274
- CAPTCHA validation, 409
- Case insensitivity, 173, 574
- Close operation, 68
- Closure, 43
- Code
  - implementation code and, 580
  - signature
    - command-line compiler, 154
    - design, 156
    - explicit signature type, 155
    - file vector.fs, 155
    - .fsi file extension, 155
    - inferred type, 154, 155
    - type-inference process, 156
- Code encapsulation and organization
  - accessibility annotation
    - checkVisitor function, 150
    - code restriction, 150
    - F# code, 151
    - GlobalClock module, 151
    - internal state, 151
    - property setters, 152
    - table protection, 150
  - code reuse
    - code compilation, 159
    - DLLs, 159
    - executable programs, 159
    - file dolphins.fs, 160
    - file whales.fs, 160
    - file whalewatcher.fs, 161
    - F# programming progress, 158
    - reusable components, 159
    - sharing and packaging mechanism, 161–162
  - encapsulation boundaries, 147

- local definiton
    - count state, 148
    - inferred types, 149
    - IPeekPoke, 148
    - IStatistic type, 149
    - let bindings, 148, 149
    - mutable state count, 149
    - variable count, 149
  - namespace and modules
    - attribute addition, 156
    - AutoOpen attribute, 158
    - client code prevention, 156
    - container types, 152, 153
    - definition, 154
    - explicit initial module declaration, 157
    - F# code fragments, 157
    - qualified names, 152
    - signature (see Code signature)
    - Vector2D, 153
    - .NET assembly, 147
    - packaging code, 147
  - Coercion operator, 101
  - collectLinks function, 289
  - COM callable wrapper (CCW), 518
  - Common Intermediary Language (CIL), 568
  - Common Language Runtime (CLR), 503, 512–514
  - Comparison operators, 89, 235
  - CompiledName attribute, 371
  - Component Object Model (COM)
    - characteristics, 516
    - Flash Player, 519–520
    - F# program
      - compiler, 517
      - F# and fsi.exe, 516–517
      - GetType method, 517
      - Quit method, 517
      - SetValue method, 517
    - .NET classes, 518
    - .NET components, 518
      - COM callable wrapper, 518
      - programming pattern, 518
      - runtime callable wrapper, 518
    - running object table
      - Marshal class, 521
      - Visual Studio, 521, 522
  - Composite formatting, 167
  - Compositional constructs, 571
  - Computation expressions. See Workflows
  - Computations
    - delayed, 486
    - precomputation and, 496
  - Compute bound application, 275
  - Concrete language format
    - ASTs
      - drawing namespace, 178
      - extractScenes, 179–180
      - inferred types, 179
      - XML conversion, 178–179
    - System.XML namespace
      - data sharing, 176
      - hierarchical structure, 176
      - interactive function, 177
      - sample fragment, 176
      - types and members, 177
  - Concrete representations, .NET Library Design
    - Guidelines and, 579
  - Concurrency objects, 136
  - Concurrent programs, 258
  - && conditionals operator, 28
  - || conditionals operator, 28
  - Connection strings, databases and, 347
  - Console.In, 103
  - Construction sequences, 116
  - Constructors, 116, 124
    - Explicit constructors and, 117
    - functions, 20
  - Content constructors, 366
  - Content.CustomContent, 367
  - Content.PageContent, 367
  - Continuation passing, 226–228
  - Conversion operators, 26, 235
  - convertToFloatAndAdd, 98
  - Copy collection, 515
  - Counting functions, 46
  - CPU parallelism, 282
  - Create method, 121
  - CreateText function, 67
  - Cross-platform solutions, 392
  - Currying, 579
  - Custom attributes, 495, 496
  - CustomContent, 366
  - Custom Control, 438–440
  - CustomEquality and CustomComparison, 218
- D**
- Databases
    - advantages of, 345
    - closing connections and, 350
    - creating, 348
    - database engine and, 346, 347
  - DataContract serialization, 93

Data Definition Language (DDL), 347  
 Data Manipulation Language (DML), 347  
 Data structures  
     concrete, 38  
     delayed, 50  
     foundational, 30  
     F# program, 14  
     hash function, 91  
     immutable, 9, 31–33, 54  
     mutable, 32, 33, 54, 62–63, 76–77  
     options, 33  
 Decimal type, 234  
 defaultArg functions, 121  
 Default keyword, 135  
 Delayed computations, 46, 78–79, 486  
 Delayed data structures, 50  
 Delegates, 100, 144  
 Delegation, 133  
 DependencyObject, 473  
 Deserialize function, 93  
 dictionariesENDRG, 62  
 Dictionary  
     hash-table structure, 60  
     key types, 60  
     KeyValuePair, 61  
     TryGetValue method, 61–62  
     with compound keys, 62  
 Discriminated unions  
     as records, 86  
     discriminator, 84  
     .NET Library Design Guidelines and, 579  
     nonextensible modules, 86  
     pattern matching, 84–85  
     recursive functions, 85  
     recursive references, 85  
     size function, 86  
     sizeOfTree, 85  
     ‘T option type, 85  
     tree-like data structures, 85  
 Discriminator, 84  
 Dispose operation, 68  
 DivideByZeroException, 234  
 <div> tag, 368  
 DllImport custom attribute, 524  
 Docking control, 432  
 do expr constructs, 275  
 do! expr constructs, 275  
 Dot (.) notation, 83  
 Double buffering, 452  
 Downcast operator, 101–102  
 Drawing namespace, 178

Dynamic Link Libraries (DLLs), 159  
 Dynamic lookups, 497  
 Dynamic memory, 515

## ■ E

emptyLists generics, 108  
 Encoding/decoding  
     binary data , 176  
     unicode strings, 175  
 Enums, 145  
 Enum types, 100  
 Equality, hashing, and comparison  
     asserting using attributes, 218  
     constraints, 217, 218  
     customizing on a type, 219–220  
     generic collection types, 221  
     generic operations, 217  
     ordered comparison, 218  
     suppressing on a type, 220  
 Equational reasoning, 572, 574  
 Error estimation, via quotations, 499  
 Euclid’s algorithm, 94, 97  
 Events, 151  
     as first-class values, 260  
     creating and publishing, 260–262  
     creating WinForms, 259  
     from .NET libraries, 259–260  
 Exception propagation, 273–274  
 Exception-related language and library constructs,  
     66  
 Exception types, 100  
 Exhaustive patterns, 35  
 Explicit arguments, 107–108  
 Explicit constructors, 117  
 Explicit factoring, 97  
 Extern keyword, 524  
 Extreme Optimization library, 245

## ■ F

F#, 295, 296  
     background of, 2  
     web site for, 6  
 Facebook  
     Class function, 409  
     configuration, 409–410  
     FB class, 409  
     IntelliFactory.WebSharper.Facebook  
         namespace, 409  
     Main.fs, 407–409  
     main HTML application

- Boolean value, 415
- Click event handler, 414
- FB.Login and FB.Logout functions, 414
- LI node, 415
- Main.fs, 411–414
- Main.html, 410–411
- Mobile.Instance.ShowPageLoadingMsg, 414
  - updateStatus function, 414
- Res.FacebookAPI resource, 409
- status messages, 406
- Visual Studio, 407
- WebSharper documentation, 409
- F# and .NET libraries
  - binary format, 504
  - C5 collection library, 509
  - COM components, 504
  - data structures, 508
    - Microsoft.FSharp.Collections, 508
    - System.Collections.Generic namespace, 509
  - DLLs, library constructs, 505
  - F# compiler, 504
  - interoperability, 512
    - COM (see Component Object Model (COM))
    - Common Language Runtime, 512–514
    - memory management, 514–516
    - types, 503
  - namespaces and, 507
  - .NET delegate type, 511
  - PowerCollections, 509
  - reflective techniques
    - general types, 510–511
    - Microsoft.FSharp.Reflection, 511
    - schema compilation, 510
- F# code
  - debugging
    - “abba” string, 544, 545
    - assertions, 549
    - attributes controlling program, 550
    - classes, 548
    - concurrent and graphical applications, 551–553
    - ConditionalAttribute, 549
    - debuggable programs, 544
    - DebuggerDisplayAttribute, 550
    - isPalindrome function, 549
    - menu, 545
    - MyComplex record, 550, 551
    - palindrome string, 544
    - program state inspection, 544
    - recursion, 544
    - System.Diagnostics namespace, 548–551
    - Visual Studio debugger (see Visual Studio debugger)
    - Watch view, 545
    - window, 545
    - WriteXXX methods, 549
  - packaging
    - application data, 542
    - command-line compiler, 538
    - conditional compilation, 538
    - data and configuration settings, 543
    - interactive scripts, 537–538
    - optimization settings, 538
    - shared libraries, 539–541
    - software entity, 541–542
    - static linking, 541
    - XML documentation, 539
  - testing
    - Category and Culture attributes, 560
    - fixtures, 561
    - FsCheck, 558
    - goal, 557
    - Ignore and Explicit attributes, 560
    - .NET debugger, 557
    - nunit-console.exe, 562
    - NUnit tool, 558–562
    - posTests and negTests functions, 559
    - setup and teardown methods, 561
    - test fixture, isPalindrome function, 558, 561
    - TestFixtureSetUp and TestFixtureTearDown attributes, 561
    - test suite, isPalindrome function, 558
    - unit tests, 559, 560
- F# command-line compiler (fsc.exe), 154
- F# compiler, 11, 12
- File handling technique, 136
- File.OpenText, 103
- FindMinMax method, 443
- FindName method, 470
- F# Interactive, 7, 465
  - Alt+Enter shortcut, 553
  - compiles code, 555
  - data structures, 14
  - development and testing, 553
  - directives, 554
  - double semicolons (;), 12
  - F# code, 11, 12
  - fsi.exe, 8
  - fsi object, 554
  - .NET Framework, 19
  - scripting, 537
  - showWordCount function, 8



- F# Interactive (*cont.*)
  - splitAtSpaces function, 8, 11
  - val keyword, 8
  - Visual Studio, 8, 556
  - wordCount function, 8
- Firebird database engine, 346
- First-in/first-out (FIFO) collection, 63
- Flexible type constraint, 104
- F# libraries, 119
  - design compliance checks and, 568
  - functional programming design techniques, 571
  - .NET Library Design Guidelines and, 565, 568
  - vanilla .NET libraries, 566
- Flickering, 452
- FLinq, 340
- float32 type, 234
- Floating constraints, 109
- Float operator, 235
- Flowlets, 359, 387
- F# operators
  - dynamic reflection operators, 497
  - quotations
    - error estimation, 499–501
    - need for, 498
    - resolving reflected definitions, 501
- Form, 20–21
- Format static method, 167
- Formatting dates, 168
- Formlets, 359
  - Android applications, 425
  - ASP.NET server control, 380–381
  - ASP.NET server-side controls, 384
  - dependent, 387
  - Enhance.Many, 386–387
  - Enhance.WithFormContainer function, 383
  - Formlet.Yield combinator, 381
  - helper function, 380
  - input field, 385
  - IntelliFactory.WebSharper.Formlet.Enhance, 381–383
  - IntelliFactory.WebSharper.Formlet namespace, 379–380
  - library features, 383
  - RunSnippet, 380
  - sitelet, 385
  - snippets, 384, 386
  - string-int pair, 386
  - text-box formlet, 379
  - validation error, 383
  - Validator.Is, 381
  - wrapper and render function, 380
- Forward pipe (|>) operator, 581
- F# PowerPack, 313
- F# program
  - calling functions, 11
  - code documentation, 9
  - data structures, 14
  - F# Interactive (*see* F# Interactive)
  - imperative code, 17–18
  - let keyword, 9
  - Lightweight Syntax, 11–12
  - object-oriented libraries (*see* Object-oriented libraries)
  - properties and dot-notation, 14–15
  - scope, 12–14
  - string analysis, duplicate words, 7
  - tuples
    - arbitrary number, 16
    - fst and snd functions, 16
    - inferred types and computed values, 16
    - patterns, 16
    - showResults function, 17
    - showWordCount function, 17
    - type-checking error, 16–17
    - values and objects, 17
    - wordCount function, 15
  - types, 10–11
  - values and immutability, 9
- F# quotations, 498
- .fsi file extension, 155
- Functional programming
  - conditionals, 28
  - currying and, 579
  - F# library design techniques, 571
  - function values. (*see* Function values)
  - and imperative programming, 49
    - memoization (*see* Memoization)
    - precomputation (*see* Precomputation)
  - lists (*see* Lists)
  - multiparadigm languages and, 565
  - numbers
    - arithmetic comparisons, 27
    - arithmetic conversions, 26
    - arithmetic operators, 26
    - binary operator, 26
    - overloaded operator, 26
    - type annotation, 26
    - types and literals, 25
  - options, 33
  - pattern matching (*see* Pattern matching)
  - recursive functions
    - alternatives, 29

- control, 29
- factorial coding, 29
- HTML fetching, 29
- List.length, 29
- mutually, 30
- nonrecursive implementation, 30
- tail recursive, 30
- well-founded, 30
- strings, 27
- types
  - definitions (*see* Type definitions)
  - generics (*see* Generics)
  - .NET types (*see* .NET types)
  - subtyping (*see* Subtyping)
  - type-inference (*see* Type inference)
- with side effects
  - imperative programming and laziness, 78
  - mutable data structures separation, 76
  - pure and side-effecting computations
    - separation, 76
  - recursion, 76
  - weak vs. strong side effects, 77
- Functions
  - currying, 579
  - generic, 500
- Function values
  - abstract control, 44
  - accumulators model, 47
  - actions model, 46
  - aggregate operators
    - Array.filter and List.map, 39
    - design pattern, 40
    - getStats function, 40
    - iteration, 44
    - pipeline operations, 40
  - anonymous, 39
  - binary operators model, 46
  - callbacks model, 46
  - concrete data structure, 38
  - counting functions model, 46
  - delayed computations model, 46
  - forward composition operator, 41
  - function fetch, 38
  - generators model, 46
  - input lists, 38
  - key functions model, 46
  - List.map, 38
  - literal list of URLs, 38
  - local functions, 42
  - object methods as first-class functions, 45
  - orderings model, 46

- output lists, 38
- partial application, 42
- predicates model, 46
- remap function, 45
- sinks model, 46
- statistical functions model, 46
- transformations model, 46
- FxCop, 566

## G

- Garbage collection, 136, 515
- g command-line flag, 161
- Generators, 46
- Generic algorithms
  - explicit arguments, 94
  - function parameters
    - concrete record type, 95
    - dictionaries of operations, 96
    - explicit factoring by functions, 97
    - hcfGeneric type, 96, 97
    - IDisposable interface, 97
    - implicit factoring by hierarchy, 97
    - object interface types, 96
    - type classes, 97
  - inlining, 97
- Generic functions, 38, 500
- Generic operators, 119
- Generics
  - algorithms (*see* Generic algorithms)
  - F# list types, 87
  - functions
    - automatic generalization, 88
    - binary serialization, 92
    - boxing and unboxing, 91
    - dummy arguments, 108
    - generic comparison, 89
    - hashing, 90
    - pretty-printing, 91
  - List.map, 87
- Generics
  - overloaded operators, 109
  - Set type, 87
  - type abbreviations, 87
  - type annotation, 88
  - type parameters, 88
  - type variables, 87, 88
- GenericZero function, 98
- getFirst, 88
- GetResponse method, 22

- GraphControl
  - AddSample method, 442, 443
  - configuration, 442
  - DataSamples class definition, 443
  - FindMinMax method, 443
  - FSharpChart, 442
  - Model-View-Controller paradigm, 443
  - plot samples, 441
  - PropertyGrid, 453
  - SplitContainer control, 453
  - style properties and controller
    - AxisColor property, 445
    - Model-View-Controller paradigm, 447
    - mouse-move events, 448
    - OnPaint drawing method, 445, 448
    - overridden vs delegation, 448
  - test application, 442
  - view
    - Background color property, 449
    - double buffering, 452
    - drawing, 449
    - OnPaint method, 449
    - paint method, 449
- Graphics objects, 136
- GUI
  - BackgroundWorker connection, 268
  - thread events code, 267

## ■ H

- Hardware design, 296
- Hash function, 90
- Haskell programming language and monads, 2, 479
- hcfGeneric function, 98, 99
- Heap allocated memory, 136
- Hello World (sample) function, 523
- Highest common factor (HCF), 94
- HTML5 standards, 392
- Hue saturation value (HSV), 455

## ■ I

- I command-line flag, 161
- i command-line option, 154
- IComparable interface, 130
- IDisposable interface, 68, 97, 130
- IEnumerable interface, 129
- IEnumerator interface, 130
- IEvent interface, 130
- if/then/elif/else construct, 28
- Immutability, 9, 27
- Immutable data structures, 9, 32, 54

- Immutable lists, 85
- Immutable values, 9
- Imperative programming, 33
  - arrays and ENDRG, 60
  - arrays
    - generation and slices, 58
    - module, 57
    - .NET types, 58
    - one-dimensional, 56
    - primitive types, 58
    - reference types, 58
    - two-dimensional, 59
    - value types, 58
  - dictionaries and ENDRG, 62
  - exceptions
    - catching, 64
    - categories, 64
    - failwith function, 63
    - function types, 63
    - GetResponse method, 63
    - new types, 65
    - System.Net.WebException, 63
    - try ... finally ... construct, 65
    - values, 63
  - and laziness, 78
  - for loops, 50
  - vs. functional programming, 49
  - and functional programming
    - memoization (*see* Memoization)
    - precomputation (*see* Precomputation)
    - with side effects, 75
- I/O techniques
  - abstractions, 68
  - file-processing, 67
  - .NET I/O via streams, 67
  - ReadLines function, 67
  - System.Console, 69
  - WriteAllLines function, 66
- loops, 50
- mutable locals, 56
- mutable records. (*see* Mutable records)
- .NET collections
  - dictionaries (*see* Dictionary)
  - other mutable data structures, 62
  - resizeable arrays, 59
- sequence loops, 51
- while loops, 51
- Implementation, 304
  - code, 580
  - inheritance, 134
  - delegation and, 133

- .NET Library Design Guidelines and, 578, 579
- Implicit arguments, 107
- constructors, 116
- factoring, 97
- Indexer properties, 21, 118, 124
- Inferred type parameters, 88
- Inferred types, 115
  - Infix function, 119
  - operators, 26, 171
- Inherit keyword, 130
- Instance members, 15, 23
- Integrating external data/services
  - language integrated OData
    - example, 335
    - handling pagination in OData, 339
    - query, 337
    - type provider, 336
  - language integrated SQL, 340
  - relational databases and ADO.NET
    - advantages of, 345
    - connecting to, 347
    - creating tables, 348
    - database engine and, 346
    - using stored procedures, 350
  - relational query operations
    - aggregation, 342
    - grouping, 344
    - inner queries, 343
    - joins, 344
    - nullables, 343
    - sorting, 342
  - REST requests
    - handling multiple pages, 334
    - JSON Format, 333
    - parsing XML/JSON data, 333
    - using WSDL services, 351
- IntelliFactory.WebSharper.Android, 415
- IntelliFactory.WebSharper.Android.Bluetooth, 416
- IntelliFactory.WebSharper.Formlet namespace, 387
- IntelliFactory.WebSharper.Formlets.JQueryMobile namespace, 425
- IntelliFactory.WebSharper.Mobile, 415
- IntelliFactory.WebSharper.Mobile.IAcceleration, 415
- IntelliFactory.WebSharper.Mobile.ICamera, 416
- IntelliFactory.WebSharper.Mobile.IGeolocator, 415
- IntelliFactory.WebSharper.Mobile.ILog, 416
- IntelliFactory.WebSharper.Sitelets, 372
- IntelliFactory.WebSharper.Sitelets.Content module, 366

- IntelliFactory.WebSharper.Web.Control, 362
- Interface inheritance, 130
- Interfaces
  - concrete types, 129
  - definition, 126, 127
  - ENDRG, 135
  - hierarchies of, 130
  - implementing, 127, 129
  - from .NET libraries, 129
  - partial implementations for, 131, 135
- Internal accessibility annotation, 150, 152
- Internal message protocols, 286
- Internet Explorer Web Browser COM component, 518
- InteropServices namespace, 524
- int operator, 235
- int type, 234
- I/O bound application, 275
- iOS devices
  - AddEventListener, 405
  - <canvas> element, 404
  - CDATA block, 400
  - Client.MyControl, 404
  - extra.files, 399
  - gesturechange event, 405
  - image viewer application, 398
  - index.html, 404
  - IntelliFactory.WebSharper.Mobile.Events class, 405
  - jQuery Mobile extensions, 404
  - Main.fs, 400
  - Main.html, 399
  - mobile events and features, 405
  - MyControl, 404
  - MySitelet, 404
  - OnAfterRender event, 404
  - OnLoad event, 404
  - scale and rotation, 405
  - virtual mouse events, 404
  - VMouseDown event, 404
- Item property, 118, 124
- Iterative worker, 264
- ITextOutputSink, 131

## J

- Java Native Interface (JNI), 524
- JavaScript.SetInterval function, 425
- JpegBitmapDecoder, 474
- JpegBitmapEncoder, 474
- JSON format, 333

Just-In-Time (JIT) compiler, 513

## K

Key functions, 46

## L

Lambda expressions and F# quotations, 498

Language integrated OData

example, 335

handling pagination in OData, 339

query, 337

type provider, 336

Language integrated SQL, 340

Language-oriented programming

quotations and, 498

reflection and, 492

workflows and, 478

relational databases and, 347

Last-in/first-out (LIFO) collection, 62

Lazy lists, 182

Lazy sequences, 192, 349

Leaf rewriting (mapping), 205

Left-to-right, leftmost derivation (LL parsers), 183

Let bindings

resolving definitions for, 501

workflows and, 482

let pat = expr constructs, 275

let! pat = expr constructs, 275

Lexers, language oriented programming, 477

Line-based input processing, 169

LINQ (Language Integrated Query), ToSql queries, 340

Lists

and arrays, 195

cons operator, 31

foundational data structures, 30

function values, 32

input, 38

language constructs and operators, 30

List.map, 38

literal, 38

module, 31

@ operations, 31

output, 38

primes type and value, 31

processing, 223

values, 30

vs. resizable arrays, 59

Literal byte arrays, 164

loadXamlWindow, 472

Local functions, 42

Local variable, 9

Lock function, 292

LoginRedirect, 371

## M

MailboxProcessor

asynchronous web crawling, 287

implementing counter, 283

member types, 286

object wrapping, 284, 285, 286

scanning mailboxes, 286

state machines, 284

Mandelbrot Viewer creation

application plumbing, 460

computing Mandelbrot, 454

delegation programming style, 454

fractals, 454

setting colors, 455

visualization application, 457

Map and filter operations, 196

mapFirst function, 107

Markup syntax, 468

Marshal class, 521

MatchCollection, 51

MatchFailureException, 36

Measure attribute, 250

membersENDRG, 114

Memoization

and caching, 75

fibFast function, 72, 74

fibNotFast function, 73

function, 72

lazy values, 74

lookaside table, 71

lookup and a discard method, 73

mutable internal tables, 74

service, 73

well-known Fibonacci function, 71

Memory model, 292

Message passing concurrency, 282

Message processing and state machines, 284

Metadata, 513

<meta> tag, 368

Method overloading, 121

Methods, .NET Library Design Guidelines and, 21, 578

Microsoft

FxCop, 566

Microsoft.FSharp.Reflection namespace, 511

Mimer SQL, 346  
 Mobile.VMouseEventArgs, 405  
 Mobile web applications
 

- Android Applications (*see* WebSharper, Android applications)
  - feature detection and polyfilling
    - Boolean value, 393
    - HasJs.Has, 394
    - HTML5 support, 393
    - JavaScript snippet, 393
    - libraries, 394
    - Modernizr, 393
    - WebSharper, 395
  - iOS devices. (*see* iOS devices)
  - mobile capabilities, 396
  - mobile frameworks, 396
  - serving mobile content, 397
  - social networking (*see* Facebook)
  - touch events, 395
  - vs. native mobile applications, 391
  - WebSharper mobile, 415

 Model-View-Controller design pattern, 441  
 Monads, 479  
 Monoids, 480  
 Multiparadigm languages, 565, 574  
 Mutable data structures, 33, 54, 62, 76  
 MutablePair class, 293  
 Mutable records
 

- aliasing, 54
- event counter, 52
- hidden mutable data, 55
- long page counter, 52
- mutable values, 52
- mutation and identity, 55
- <- operator, 52
- reference cells, 53

 Mutable reference cells, 53  
 Mutable state, 122  
 Mutually recursive functions, 30  
 MyExternalResource, 388  
 MySQL, 346

## ■ N

Named arguments, 120  
 Naming conventions, 576
 

- interfaces and, 126
- object interface types and, 130
- per .NET Library Design Guidelines, 574

 Nativeint type, 234  
 Negation normal form (NNF), 215

N escape character, 165  
 .NET asynchronous operations, 279  
 .NET CLR, 258  
 .NET collections, 91  
 .NET event handlers, 259  
 NET interoperability, 193  
 NET libraries
 

- vanilla, 566

 .NET libraries. *See* F# and .NET libraries
 

- binary serialization, 92
- imperative code, 18
- object-oriented libraries, 18
- text.Split, 19
- XML, 23

 NET Library Design Guidelines, 565
 

- applying to F# programming, 574
- checking for compliance with, 568

 .NET methods, 45, 51  
 .NET proxies, 389  
 .NET shared-memory concurrency primitives, 294  
 .NET thread pool, 273  
 NET ToString() method, 91  
 .NET types
 

- attribute types, 100
- delegate types, 100
- enum types, 100
- exception types, 100
- reference types, 99
- value types, 99

 Network connections, 136  
 NoComparison and NoEquality, 218  
 Nonexhaustive matches, 36  
 Non-numeric types, 25, 233  
 Northwnd sample database, 340  
 Not a Number (NaN) values, 235  
 Null values, 145  
 numDups, 8  
 Numeric data, 231
 

- built-in aggregation operators
  - advantage, 239
  - complex relationship, 241
  - computation, 237
  - counting and categorization, 239
  - KMeans clustering algorithm, 242
  - numeric code writing, 240
  - Seq.maxBy operator, 238
  - Seq.minBy operator, 239
  - Seq.sumBy operator, 238
  - unitized/generic code, 241
- charting with FSharpChart, 231, 232, 233
- .NET math library

Numeric data, .NET math library (*cont.*)  
 and frameworks, 245  
 characteristics, 244  
 eigenvalues and eigenvectors of matrix, 250  
 histograms and distributions, 246  
 inverse matrix, 249  
 matrices and vectors, 248  
 matrix decomposition, 249  
 statistical function, 245  
 types and literals  
   arithmetic conversion, 235  
   arithmetic operators, 234  
   bitwise operations, 236  
   bool and unit, 233, 234  
   checked arithmetic, 234  
   comparison operators, 235  
   overloaded Math functions, 236  
 units of measure  
   annotations, 250, 251  
   applications, 250  
   apply and removal of units, 254  
   attribute, 250  
   computation, 250  
   data sequence, 253  
   generic algorithm, 251  
   KMeans algorithm, 255  
   limitations, 254  
   linear function, 252  
   numerical-integration techniques, 251  
   parameters, 253  
   variance function, 252  
   vector type, 253, 254  
 Numeric types, 25, 26  
 numWords, 8

## O

Object expressions, formatting, 581  
 Object identity, 9  
 Object interface types, design guidelines, , 96, 579  
 object interface types. *See* Interfaces , 126  
 Object Linking and Embedding (OLE) technology, 516  
 Object-oriented libraries  
   fetching Web Page, 22  
   .NET libraries, 18  
   new keyword, setting properties, 20  
   open keyword, namespaces and modules, 19  
 Object-oriented (OO) programming, 225  
   functional programming and, 565  
   library design and, 571, 573  
   .NET Library Design Guidelines and, 578

Object programming  
 classes  
   construction sequence, 116  
   constructors, 116  
   explicit constructors, 117  
   generic instantiation, 117  
   inferred type, 115  
   length precomputation, 114, 115  
   Scale method, 116  
   static bindings, 117  
   symmetry, 114  
 cleanup resource  
   IDisposable, 136  
   lexical scope, 135  
   operating-system resources, 135  
 F# object and .NET types  
   delegates, 144  
   delimitation, 143  
   enums, 145  
   null values, 145  
   structs, 144  
 modules extension  
   code organization, 143  
 mutable state  
   auto-property, 125  
   complexity, 124  
   currDX and currDY, 123  
   definition, 122  
   indexer property, 124  
   inferred signature type, 123, 124  
   optional property settings, 124, 125  
   Vector2D type, 122  
 notational convenience  
   dot notation, 117  
   indexers property, 118  
   method overloading, 121, 122  
   named arguments, 120, 121  
   optional arguments, 120, 121  
   overloaded properties, 118, 119  
 object interface types  
   abstract types, 126  
   concrete types, 129  
   definition, 127  
   hierarchies of, 130, 131  
   implementation variations, 126  
   IShape, 126, 127  
   from .NET libraries, 129, 130  
   object expression, 127, 128  
   objects and members, general rules, 114  
 partial implementation  
   abstract members, 133

- concrete types, 133
- creation, 131
- delegation, 133, 134
- function parameter, 131, 132
- implementation inheritance, 134
- object expression, 131, 132
- objects, 135
- Observables, 290
- OCaml
  - library design and, 566
  - underscore (`_`) and, 576
- OCaml programming language, 2
- O command-line flag, 161
- Offline sitelets, 364
- On-demand computation, 206
- Online sitelets, 365
- OnPaintBackground method, 436
- OpenText function, 68
- Operator overloading, 235
- Operators, 290
  - infix, 171
  - recommendations for using, 581
- Optional arguments, 120
- Optional property settings, 124
- Option values, .NET Library Design Guidelines and, 577
- Oracle database engine, 346
- Out parameter, 61
- Outscope values, 13
- Override keyword, 135
- Overriding methods, 447

## P

- Packaging code, abbreviations, 153
- Padding, 516, 526
- PageContent, 366
- Pagelets, 359, 360
- Pages.ProtectedPage, 371
- Parallel programs, 258
  - Parser combinators, language-oriented programming and, 477, 186
- Partial and parameterized active patterns, 214
- Pattern matching, 21, 28, 286
  - form patterns, 37
  - guarding rules and combining patterns, 36
  - inferred type function, 34
  - isLikelySecretAgent, 34
  - keyword, 34
  - list values, 34
  - match ... with ... construct, 34
  - option, 33, 35
  - primes, 35
  - rule, 34
  - strings and integers, 34
  - structured values, 35
  - subtyping, 102
  - tuple, 34
- Performance guidelines (*see* Guidelines)
- Persistent data structure. (*see* Immutable data structures)
- Pickering, Robert, 478
- Pinning, 527
- Pipeline operations, 40, 581
- Pipelining, 193
- Placeholders, 367
- Platform Invoke
  - calling conventions
    - activation record, 522
    - fcall convention, 523
    - memory leak, 523
    - stdcall and cdecl convention, 523
    - thread stack, 523
- C data structures mapping
  - definition, 525
  - StructLayout custom attribute, 525
  - SumC prototype, 526
- definition, 522
- DllImport custom attribute, 524
- execute native code, 524
- extern keyword, 524
- function pointers, 530
- functions, 522
- Hello World (sample) function, 523, 524
- interopServices namespace, 524
- Java Native Interface, 524
- marshalling parameters
  - function pointers, 526
  - native code, 526
  - native functions, 527
  - padding, 526
  - strings, 526
  - ZeroC function, 526, 527
- marshalling strings
  - ANSI C strings, 529
  - C function, 528
  - default conversions, 528
  - F# PInvoke prototype, 529
  - sayhello function, 529
  - string buffer, 529



- Platform Invoke, marshalling strings (*cont.*)
  - System.Text.StringBuilder object, 529
  - memory mapping, 531, 533, 534
  - parameter passing, 525
  - Sum function, 524
  - wrapper generation limitations, 534, 535
- Polymorphism, 128
- PostAndReply, 286
- PostgreSQL, 346
- PowerCollections library, 509
- precomputation, 496
- Precomputation
  - and objects, 70
  - and partial application, 69
- Primary constructors, 116, 124
- Printf module and function, 17, 165
- Private accessibility annotation, 150
- probabilistic workflows, 487
- Procedural programming, library design and, 571
- Progressive enhancement, 392
- rProperties, design guidelines
- PropertyGrid, 453
- Propositional logic
  - AndL function, 301
  - arrays of propositions, 301
  - BDD
    - circuit verification, 307
    - Equiv, 306
    - language representation techniques, 304
    - logical rules, 306
    - mkAnd operation, 306
    - pretty-printer installation, 306
    - Prop representation, 306, 307
    - ToString member, 306
  - circuit components, code, 300
  - circuits property, checking, 303
  - formulae evaluation, 298
  - halfAdder, propositional formula, 302
  - hardware circuits, 300
  - minimalistic representation, 297
  - N-bit adder, 301
  - primitive propositions, 297
  - Prop formula, 297
  - QBF, 296
  - truth tables, 299
  - twoBitAdder, 302
- Public accessibility annotation, 150, 151, 152

## ■ Q

- Qualified names, 152

- Quantified Boolean formulae (QBF), 296
- Queries. *See* also Relational query operations
- Query, definition, 337
- Quotations
  - example of, 499
  - rationale for using, 498

## ■ R

- RandomTicker, 260
- Range expressions, 190
- r command-line flag, 161
- Reactive programs, 258
- ReadAllLines function, 67
- ReadAllText function, 67
- ReaderWriterLock, 293
- readValue function, 92
- Records
  - cloning, 84
  - discriminated unions, 86
  - F# Interactive, 83
  - heterogeneous results, 82
  - labels, 82
  - .NET Library Design Guidelines and, 579
  - non-unique field names, 83
  - stats, 82
  - type annotation, 82
  - type.field syntax, 82
- Records, relational databases and, 348
- Recursive functions
  - alternatives, 29
  - control, 29
  - discriminated unions, 85
  - factorial coding, 29
  - HTML fetching, 29
  - List.length, 29
  - mutually, 30
  - nonrecursive implementation, 30
  - tail recursive, 30
  - well-founded, 30
- Recursive workflow expressions, 492
- redraw() function, 404
- Reference types, 99
- Reflection
  - types and, 493
  - library, 496
- reflection, 492
- Regular expressions, 163
- Relational databases and language
- Relational databases and ADO.NET
  - advantages of, 345

- connecting to \r conn, 347
- creating, 348
- creating tables, 348
- database engine and, 346
- using stored procedures, 350
- Relational query operations
  - aggregation, 342
  - grouping, 344
  - inner queries, 343
  - joins, 344
  - nullables, 343
  - sorting, 342
- RequestGate, 289
- Require attribute, 388
- R escape character, 165
- Resgen.exe tool, 543
- ResizeArray module, 60
- Resource lifetime management, 274
- Resources, combine with workflows
- Resources.BaseResource, 388
- Resources for further reading, mmeasure, 255
- Responsive web design, 392REST requests
  - handling multiple pages, 334
  - JSON Format, 333
  - parsing XML/JSON data, 333
- return expr constructs, 275
- return! expr constructs, 275
- RichTextBox control, 21
- Runtime callable wrapper (RCW), 518
- Runtime type, 101

## S

### Samples

- error estimation, quotations and, 499
- workflows, 480
- sbyte operator, 235
- sbyte type, 233
- Schemas, type reflection, 493
- Scope, 12
- Sequence expressions and workflows, 478
- Sequences
  - aggregate operators, 191
  - compatible types, 192
  - expressions, 58, 60, 349
  - finding elements and indexes, 199
  - folding sequences, 201
  - grouping and indexing, 200
  - iteration, 191
  - lazy sequences, 192
  - map and filter operations, 196

- selecting multiple elements, 198
- truncate and sort operations, 197
- using range expressions, 190
- using sequence expressions
  - additional logic, 194
  - cleaning up, 202
  - computation expressions, 194
  - expressing operations, 203
  - generating lists and arrays, 195
- Serialize function, 93
- Serializer, 93, 94
- Server-side functionality, 363
- Set.ofList function, 14
- setTextOfControl function, 103
- settleDelta() function, 404
- Shared-memory concurrency, 282
  - concurrency primitives, 294
  - explicit thread creation, 291
  - race conditions and .NET memory model, 291
  - using locks, 292
  - using ReaderWriterLock, 293
- showResults function, 17
- ShowVisualTree function, 473
- showWordCount function, 17
- Side effects and workflows, 485
- Signature types/signature files, and guidelines, 578
- Silverlight, 465
- Sinks, 46
- Sitelet.Filter value, 371
- Sitelet.Infer constructor, 370
- Sitelets
  - Action.MyPage action, 364
  - Action type, 364
  - client-side controls, 368
  - construction, 369
  - dynamic templates, 367
  - non-GET HTTP commands
    - basic menu and order creation form, 376
    - conceptual mapping, 373
    - Create Order and List Orders pages, 379
    - CreateOrderForm, 374
    - formlet, 374
    - helper functions, 374
    - JSON representation, 378, 379
    - ListOrders, 374
    - Main.fs file, 373, 374
    - Main.html file, 373, 374
    - order attributes, 373
    - order storage, 373
    - POST and PUT requests, 378
    - response content functions, 377

- Sitelets, non-GET HTTP commands (*cont.*)
  - specific order retrieval, 376
  - online vs. offline, 364
  - routers and controllers, 372
  - serving content, 365
  - single-page sitelet, 363
  - Sitelets.Website attribute, 364
- Sitelet.Sum combinator, 372
- Slice notation, 58
- Smart web applications
  - Ajax rich client applications
    - development methods, 358
    - WebSharper (*see* WebSharper)
  - web server
    - arbitrary TCP server, 356
    - asynchronous task, 356
    - cloud-computing solutions, 358
    - coding in F#, 354
    - GET request, 356
    - HTTP commands, 353
    - quote server, 356
    - Regex1, 356
    - scaling, 358
    - SSL server, 357
    - TCP socket connection, 355
- splitAtSpaces function, 11
- SplitContainer control, 453
- sprintf function, 165
- SQLite, 346
- SQL Server Express, 346, 347
- Stack- and heap-allocated memory, 222
- Stack, resources, 136
- Static members, 15, 23
- Static memory, 514
- Statistical functions, 46
- stdcall calling convention, 530
- stored procedures, 350
- Stream, 69
- StreamReader, 68, 78
- StreamWriter, 67
- StringBuilder, 67
- String placeholder, 368
- StringReader, 68
- Strings
  - formatting, 163, 167
  - parsing, 170
  - printfn function and, 165
  - regular expressions and, 171
  - sprintf function and, 165
  - unicode encoding/decoding and, 175
- StringWriter, 67
- StructLayout custom attribute, 525
- Structs, 144
- Structural comparison, 89
- StructuralEquality and StructuralComparison, 218
- Structural formatting, 167
- Structural hashing, 62
- Structured data
  - active patterns (*see* Active patterns)
  - equality, hashing, and comparison. (*see* Equality, hashing, and comparison)
- Structured Query Language (SQL), 347
- Subarrays, 58
- Submodules, 153
- Subtyping
  - automatic upcasting, 102
  - dynamic casting, 101
  - flexible types, 104
  - .NET types, 99
  - pattern matching, 102
  - static casting, 101
- SWIG wrapper generator, 535
- Sybase iAnywhere, 346
- Symbolic differentiation
  - algebraic expression
    - abstract syntax representation, 313, 314
    - ExprUtil.fs, 313, 320
    - main Expr type, 313
    - parsing, 315
    - simplifications, 317
    - StarNeeded member, 315
    - VisualExpr.fs, 313
    - Visual Studio 2012, 313
  - expression rendering
    - code, 326
    - expressions and sizes, 323
    - rendering options, 320
    - RenderOptions type, 320
    - visual elements and sizes, 321
    - VisualExpr, 323
  - local simplifications, 312
  - simple algebraic expressions modeling, 310
  - user interface client, 327
  - visual application, 310
- Symbolic programming. *See* Propositional logic
- Synchronization context, 268
- Syntax member, object expressions and, 581
- Syntax trees, 228
- System namespace
  - core types, 508
  - supervising and program execution, 509
  - useful services, 508

System.Net library, 22  
 System.Net.WebRequest, 22  
 System.Object.ReferenceEquals function, 55  
 System.Reflection namespace, 493  
 System.Text.RegularExpressions, 171  
 System.Text.RegularExpressions.Regex.Matches, 51  
 System.Threading.AutoResetEvent, 294  
 System.Threading.Interlocked, 294  
 System.Threading.ManualResetEvent, 294  
 System.Threading.Mutex, 294  
 System.Threading.Semaphore, 294  
 System.Threading.WaitHandle, 294  
 System.Windows.Forms.Form, 20

## T

Tables, relational databases and, 348  
 Tail calls and recursive programming  
     and list processing, 223  
     object-oriented programming, 225  
     processing syntax trees, 228  
     processing unbalanced trees, 226  
     simple tail-recursive function, 222, 223  
     stack- and heap-allocated memory, 222  
     using continuations, 227  
 telnet.exe, 419  
 Text label, 20  
 TextOutputSink object, 133  
 TextReader, 68  
 text.Split, 19  
 Textual data  
     binary parsing and formatting  
         advantages, 184, 185  
         combinator-based pickling, 186  
         data aggregation, 185  
         data reliability, 183  
         marshalling, 183  
         picklers and unpicklers, 183  
         primitive read/write functions, 184  
     concrete type. (*see* Concrete language format)  
     data format  
         ASCII characters, 164  
         building strings, 163  
         code, printf style, 166  
         escape characters, nonverbatim strings, 165  
         generic structural formatting, 167  
         .NET formatting, 167  
         %O/%A pattern, 166  
         printfn and sprintf functions, 165  
         printfn module, 165  
         string and character laterals, 164

triple-quote string laterals, 164  
 parsing strings  
     basic value, 168  
     encoding and decoding. *See* Encoding/  
         decoding  
     line-based input processing, 169, 170  
     regular expressions, 170  
     System.Text.RegularExpressions, 171, 172,  
         173, 174  
 recursive descent parsing  
     information extraction, 180  
     lazy lists generation, 182  
     LL parsers, 183  
     polynomials, 182  
     symbolic differentiation, 180  
     tokenizer for polynomials, 181  
 TextureBrush, 435  
 TextWriter, 68, 69  
 Thread hopping, 272  
 Threads, 258  
 Top-down rewriting, 205  
 Top-level members, resolving, 501  
 TopMost label, 20  
 Transact-SQL (T-SQL), 347  
 Transformations, 572  
 TRANSFORM\_CALLBACK type, 530  
 Transformers model, 46  
 Truncate and sort operations, 197  
 TryGetValue method, 61  
 T-SQL (Transact-SQL), 347  
 Tuples  
     arbitrary number, 16  
     fst and snd functions, 16  
     hash function, 91  
     inferred types and computed values, 16  
     .NET Library Design Guidelines and, 580  
     patterns, 16  
     showResults function, 17  
     showWordCount function, 17  
     type-checking error, 16  
     values and objects, 17  
     wordCount function, 15  
 Two-dimensional arrays, 59  
 Type abbreviations, 81, 153  
 Type annotations, 15, 88, 105  
 Type classes, 97  
 Type constraint, 92, 105  
 Type constructors, 10

- Type definitions
  - discriminated unions (*see* Discriminated Unions)
  - multiple types, 87
  - record (*see* Records)
  - type abbreviations, 81
- Type function, 108
- Type inference, 10, 11, 41, 45, 193
  - explicit factoring, 97
  - generic functions, 88
  - subtyping, 100
  - troubleshooting
    - generic overloaded operators, 109
    - type annotations, 105
    - value restriction. (*see* Value restriction)
    - visual editing environment, 105
  - type classes, 97
- Type of operator, 493
- Type parameters, 38, 92
- Type PingPong, 106
- Type provider, 336
- Types
  - language-oriented programming and, 477, 478
  - .NET Library Design Guidelines and, 578
  - partially implemented, 135
  - reflection and, 493
- Type signatures, 89, 90
- Type StreamReader, 103
- Type-test patterns, 64, 102
- Type TextReader, 103
- Type TimeSpan, 44
- Type variable, 45

## U

- uint16 operator, 235
- uint16 type, 233
- uint32 operator, 235
- uint32type, 234
- uint64 operator, 235
- uint64 type, 234
- Unativeint type, 234
- Unbox function, 92
  - binary serialization, 92, 93
  - dynamic casting, 101
  - .NET types, 99
- Underscore (`_`), 576
- Ungeneralized type variables, 106
- UNNNNNNNN escape character, 165
- Upcast operator, 101
- urlCollector, 289

- use pat = expr constructs, 275
- UserControl class, 438
- Utils.SimpleContent function, 369

## V

- Value restriction
  - automatic generalization, 106
  - definition, 106
  - empty lists, 106
  - explicit type arguments, 108
  - generic functions
    - dummy arguments, 108
    - explicit arguments, 107
  - nongeneric constrain values, 107
- Values, 21
  - types, 99
  - .NET Library Design Guidelines and, 577
- vanilla .NET libraries, 566
- Verbatim strings, 164, 172
- VerifyUser, 371
- Visible label, 20
- Visualization and Graphical User Interfaces
  - control
    - anatomy of, 441
    - docking and anchoring, 432
    - Dock property, 430
    - fsi.exe., 431
    - layout, 432
    - placing controls, 429
    - registering controls, 429
    - single thread apartment model, 429
    - STAThread, 429
    - status bar, 430
    - Visual designers, 432
    - Web browser application, 430
    - WebBrowser control, 431
    - Windows Forms, 431
  - creation (*see* Mandelbrot Viewer creation)
  - drawing applications
    - Bézier curve, 434
    - brushes and pens, 435
    - canonical splines, 434
    - control point, 436
    - curves application, 436
    - movingPoint variable, 436
    - OnPaintBackground method, 436
    - paint-based model, 434
    - window, 434
  - graphical applications, 428
  - Hello, World! application, 427

sensor samples. *See* `GraphControl`  
 WPF (*see* Windows Presentation Foundation (WPF))  
 Visual Studio, 23, 350  
 Visual Studio debugger  
   debugging session, 545  
   features, 546  
 Visual Studio's COM automation model, 521  
 VSLab Viewlets, 440

**W**

WebRequest object, 22  
 WebSharper  
   Android applications  
     Android emulator, 417  
     ApplicationControl server control, 425  
     Client.BingMapsKey, 424  
     Client module, 424  
     Controls.Password function, 425  
     Controls.TextField function, 425  
     device configuration, 420  
     Enhance.WithSubmitButton function, 425  
     formlet code, 425  
     formlets, 417  
     installation and set up, 418  
     Main.fs, 422  
     Main.html, 421  
     MapOptions, 425  
     SDK documentation, 419  
     SDK Manager, 418, 419  
     setMap, 425  
     ShowMap() function, 425  
     tools, 419  
     updateLocation, 425  
     Visual Studio template, 420  
   ASP.NET-compatible server-side application, 359  
   automated resource tracking and handling, 387  
   documentation, 359  
   feature detection and polyfilling, 395  
   flowlets, 359, 387  
   formlets (*see* Formlets)  
   mobile, 415  
   .NET proxies, 389  
   pagelets, 359, 360  
   Rich Internet Applications (RIAs), 360  
   server code, 362  
   sitelets (*see* Sitelets)  
   third-party JavaScript libraries, 388  
   Visual Studio 2010, 360

WebSharper script manager control, 362  
 Well-founded recursion, 30  
 Whitespace, regular expression and, 172  
 Wildcard patterns, 34, 36  
 Windows Forms  
   articulated frameworks, 429  
   brushes and pens, 435  
   COM components, 429  
   coordinate transformation, 449  
   DataSamples, 445  
   event loop, 428  
   F# Interactive, 466  
   fsi.exe, 429  
   OnPaintBackground method, 436  
   System.Windows.Application class, 466  
   User controls, 438  
   VSLab, 440  
   WPF's layout model, 466  
 Windows Presentation Foundation (WPF)  
   bitmaps and images, 474  
   controls  
     ButtonChrome node, 473  
     data-binding expression, 474  
     DependencyProperty class, 473  
     FindName method, 472  
     loadXamlWindow, 472  
     logical tree, 472  
     nested controls, 472  
     opaque, 471  
     ShowVisualTree function, 473  
     TextBox implementers, 473  
     Text property, 473  
     visual tree, 472  
   definition, 465  
   dependency properties and animations, 466  
   drawing  
     application, 467  
     markup syntax, 468  
     window's visual tree, 468  
     XAML (*see* XAML)  
   event loop, 465  
   FSharp.TypeProviders package, 465  
   layout model, 466  
   .NET framework, 465  
   paint-event-based paradigm, 467  
   retention-based, device-independent rendering, 466  
   Silverlight, 465  
   toolkit model, 467  
   Turbo Pascal, 466  
   Win32 and GDI rastering engine, 476

- Windows Presentation Foundation (*cont.*)
  - window from F# Interactive, 465
  - XML-based composition language, 466
- Window.xaml code, 469
- wordCount function
  - calling functions, 11
  - code documentation, 9
  - F# Interactive, 8
  - Length and Count, 14
  - let keyword, 9
  - lightweight syntax, 11, 12
  - scope, 12
  - tuple, 15
  - type, 10
- workflows
  - examples of, 480
  - workflows (computation expressions), 194
    - builder for, 478, 483, 488
    - combining with resources, 492
    - constructs, 479
    - how they work, 478
    - key uses of, 478
    - probabilisticBEGINRG, 487
    - probabilisticENDRG, 491
    - recursive workflow expressions and, 492
    - resources cleanup and , 492
    - side effects and, 485
    - success/failure and, 480
    - terminology and, 480
    - with custom query operators, 486
  - workflowsENDRG, 492
  - writeCharFunction parameter, 131
  - WriteLine functions, 167
  - writeValue function, 92
  - WSDL services, 351

## ■ X, Y

### XAML

- ASP.NET files, 468
- BAML, 468
- Blend and Visual Studio, 465
- business logic, 469
- coordinate system, 470
- C# source files, 468
- FindName method, 470
- F# project system, 468
- FSharpX type, 469
- F# source code, 465
- graphical elements, 469
- Microsoft Expression Blend, 469
- source-code generation, 468
- transformed elements composition, 470
- Visual Studio, 469
- visual tree, 469
- Window class, 468
- window definition, 468
- WYSIWYG editor, 469
- XML, 23
  - language-oriented programming and, 477
- XmlAttribute type, 177
- XmlDocument type, 177
- Xml namespace, 176
- XmlNode type, 177
- XmlReader type, 177
- XmlWriter type, 177
- XPath, 180

## ■ Z

- zeroCreate function, 146