

SUBCELLULAR BIOCHEMISTRY  
Volume 44

# Peroxioredoxin Systems

Structures and Functions

Edited by

Leopold Flohé and  
J. Robin Harris

 Springer

# Peroxiredoxin Systems

Subcellular Biochemistry

Volume 44

# SUBCELLULAR BIOCHEMISTRY

## SERIES EDITOR

J.ROBIN HARRIS, University of Mainz, Mainz, Germany

## ASSISTANT EDITORS

B.B. BISWAS, University of Calcutta, Calcutta, India

P.QUINN, King's College London, London, U.K

---

### *Recent Volumes in this Series*

- Volume 31 **Intermediate Filaments**  
Edited by Harald Herrmann and J. Robin Harris
- Volume 32 **alpha-Gal and Anti-Gal: alpha-1,3-Galactosyltransferase, alpha-Gal Epitopes and the Natural Anti-Gal Antibody**  
Edited by Uri Galili and Jos-Luis Avila
- Volume 33 **Bacterial Invasion into Eukaryotic Cells**  
Tobias A. Oelschlaeger and Jorg Hacker
- Volume 34 **Fusion of Biological Membranes and Related Problems**  
Edited by Herwig Hilderson and Stefan Fuller
- Volume 35 **Enzyme-Catalyzed Electron and Radical Transfer**  
Andreas Holzenburg and Nigel S. Scrutton
- Volume 36 **Phospholipid Metabolism in Apoptosis**  
Edited by Peter J. Quinn and Valerian E. Kagan
- Volume 37 **Membrane Dynamics and Domains**  
Edited by P.J. Quinn
- Volume 38 **Alzheimer's Disease: Cellular and Molecular Aspects of Amyloid beta**  
Edited by R. Harris and F. Fahrenholz
- Volume 39 **Biology of Inositols and Phosphoinositides**  
Edited by A. Lahiri Majumder and B.B. Biswas
- Volume 40 **Reviews and Protocols in DT40 Research**  
Edited by Jean-Marie Buerstedde and Shunichi Takeda
- Volume 41 **Chromatin and Disease**  
Edited by Tapas K. Kundu and Dipak Dasgupta
- Volume 42 **Inflammation in the Pathogenesis of Chronic Diseases**  
Edited by Randall E. Harris
- Volume 43 **Subcellular Proteomics**  
Edited by Eric Bertrand and Michel Faupel
- Volume 44 **Peroxiredoxin Systems**  
Edited by Leopold Flohé and J. Robin Harris

# Peroxioredoxin Systems

Structures and Functions

Subcellular Biochemistry

Volume 44

Edited by

Leopold Flohé

*MOLISA GmbH Magdeburg, Germany*

and

J. Robin Harris

*University of Mainz, Germany*



Springer

This series is a continuation of the journal Sub-Cellular Biochemistry. Volume 1 to 4 of which were published quarterly from 1972 to 1975

ISBN 978-1-4020-6050-2 (HB)

ISBN 978-1-4020-6051-9 (e-book)

---

© 2007 Springer

All rights reserved. This work may not be translated or copied in whole or in part without the written permission of the publisher (Springer Science + Business Media, Inc., 233 Springer street, New York, NY 10013, USA), except for brief excerpts in connection with review or scholarly analysis. Use in connection with any form of information storage and retrieval, electronic adaption, computer software, or by similar or dissimilar methodology now known or hereafter developed is forbidden.

The use in this publication of trade names, trademarks, service marks and similar terms, whether or not they are subject to proprietary rights.

(BS/DH)

9 8 7 6 5 4 3 2 1

springer.com

## INTERNATIONAL ADVISORY EDITORIAL BOARD

R. BITTMAN, Queens College, City University of New York, New York, USA

D. DASGUPTA, Saha Institute of Nuclear Physics, Calcutta, India

H. ENGELHARDT, Max-Planck-Institute for Biochemistry, Munich, Germany

L. FLOHE, MOLISA GmbH, Magdeburg, Germany

H. HERRMANN, German Cancer Research Center, Heidelberg, Germany

A. HOLZENBURG, Texas A&M University, Texas, USA

H-P. NASHEUER, National University of Ireland, Galway, Ireland

S. ROTTEM, The Hebrew University, Jerusalem, Israel

M. WYSS, DSM Nutritional Products Ltd., Basel, Switzerland

P. ZWICKL, Max-Planck-Institute for Biochemistry, Munich, Germany

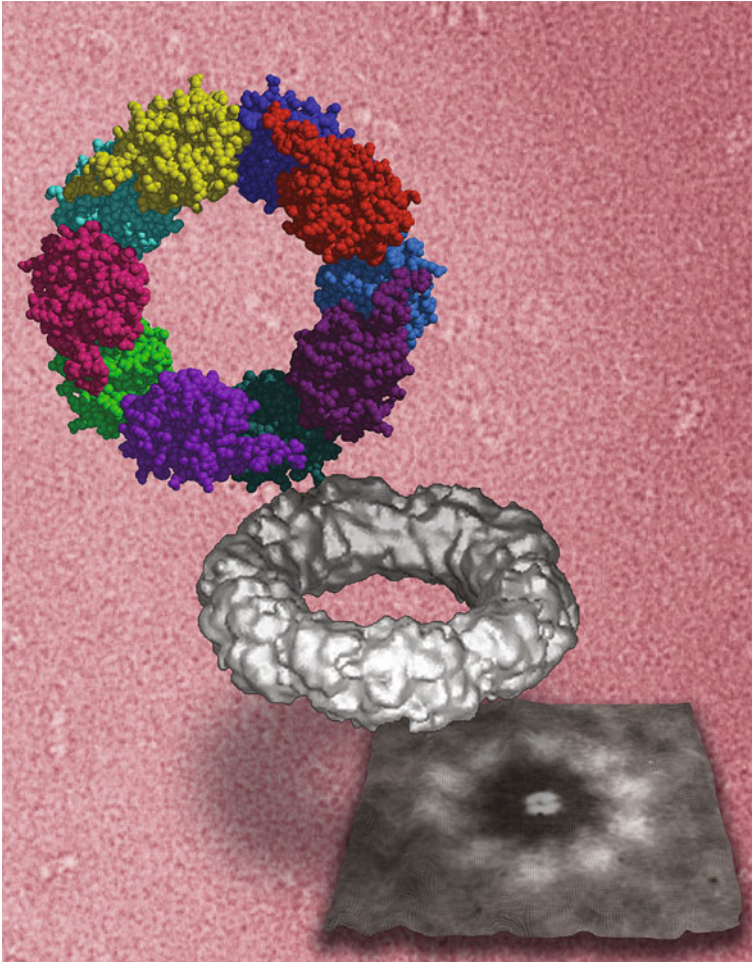

## CONTENTS

List of Contributors	ix
Preface	xiii
1. Introduction Leopold Flohé and J. Robin Harris	1
2. Evolution of the Peroxiredoxins Bernard Knoops, Eléonore Loumaye and Valérie Van Der Eecken	27
3. Structural Survey of the Peroxiredoxins P. Andrew Karplus and Andrea Hall	41
4. The Catalytic Mechanism of Peroxiredoxins Leslie B. Poole	61
5. Kinetics of Peroxiredoxins and their Role in the Decomposition of Peroxynitrite Madia Trujillo, Gerardo Ferrer-Sueta, Leonor Thomson, Leopold Flohé and Rafael Radi	83
6. The Peroxiredoxin Repair Proteins Thomas J. Jönsson and W. Todd Lowther	115
7. Peroxiredoxins in Bacterial Antioxidant Defense James M. Dubbs and Skorn Mongkolsuk	143
8. The NADH Oxidase-Prx System in <i>Amphibacillus Xylanus</i> Youichi Niimura	195
9. Peroxiredoxin Systems in Mycobacteria Timo Jaeger	207
10. Peroxiredoxin Systems of Protozoal Parasites Marcel Deponte, Stefan Rahlfs and Katja Becker	219



11. The Trypanothione System Luise R. Krauth-Siegel, Marcelo A. Comini and Tanja Schlecker	231
12. Functions of Typical 2-Cys Peroxiredoxins in Yeast Brian A. Morgan and Elizabeth A. Veal	253
13. The Dual Function of Plant Peroxiredoxins in Antioxidant Defence and Redox Signaling Karl-Josef Dietz	267
14. Mitochondrial Peroxiredoxins Zhenbo Cao, J. Gordon Lindsay and Neil W. Isaacs	295
15. Peroxiredoxins in the Lung with Emphasis on Peroxiredoxin VI Bruno Schremmer, Yefim Manevich, Sheldon I. Feinstein and Aron B. Fisher	317
16. Peroxiredoxins in Gametogenesis and Embryo Development Isabelle Donnay and Bernard Knoops	345
17. Peroxiredoxins in the Central Nervous System Fumiyuki Hattori and Shinzo Oikawa	357
18. Stress-Induced Peroxiredoxins Tetsuro Ishii And Toru Yanagawa	375
Index	385

## LIST OF CONTRIBUTORS

Katja Becker

Interdisciplinary Research Center, Justus Liebig University, Heinrich-Buff-Ring 26–32, D-35392 Giessen, Germany

Zhenbo Cao

Division of Biochemistry and Molecular Biology, Davidson Building, Institute of Biomedical and Life Sciences, University of Glasgow, Glasgow G12 8QQ, UK

Marcelo A. Comini

Biochemie-Zentrum der Universität Heidelberg, Im Neuenheimer Feld 504, D-69120, Heidelberg, Germany

Marcel Deponte

Interdisciplinary Research Center, Justus Liebig University, Heinrich-Buff-Ring 26–32, D-35392 Giessen, Germany

Karl-Josef Dietz

Biochemistry and Physiology of Plants, Faculty of Biology W5-134, University of Bielefeld, 33501 Bielefeld, Germany

Isabelle Donnay

Veterinary Unit, Institut des Sciences de la Vie, Université catholique de Louvain, Place Croix du Sud, 5, B-1348 Louvain-La-Neuve, Belgium

James M. Dubbs

Laboratory of Biotechnology, Chulabhorn Research Institute, Lak Si, Bangkok 10210, Thailand.

Sheldon I. Feinstein

Institute for Environmental Medicine, University of Pennsylvania, Philadelphia, PA 19104, USA

Gerardo Ferrer-Sueta

Center for Free Radical and Biomedical Research, Facultad de Medicina, Universidad de la República, 11800 Montevideo, Uruguay, and Instituto de Química

Biológica, Facultad de Ciencias, Universidad de la República, 11400 Montevideo, Uruguay

Aron B. Fisher  
Institute for Environmental Medicine, University of Pennsylvania. Philadelphia, PA 19104, USA

Leopold Flohé  
MOLISA GmbH, Universitätsplatz 2, D-39106 Magdeburg, Germany *Home address:* Rudolf-Breitscheid-Str. 184, D-14482 Potsdam, Germany

Andrea Hall  
Department of Biochemistry and Biophysics, Oregon State University, Corvallis, OR 97331

J. Robin Harris  
Institute of Zoology, University of Mainz. D-55099 Mainz, Germany *Home address:* 11 Hackwood Park, Hexham, Northumberland, NE46 1AX, UK

Fumiyuki Hattori  
Asubio Pharma Co. Ltd.  
Research park, Institute of Integrated Medical Research Keio University School of Medicine, Tokyo, Japan

Neil W. Isaacs  
WestCHEM, Department of Chemistry, University of Glasgow, Glasgow G12 8QQ, UK

Tetsuro Ishii  
Majors of Medical Sciences, Graduate School of Comprehensive Human Sciences, University of Tsukuba, Tsukuba, Ibaraki, 305–8575 Japan

Timo Jaeger  
MOLISA GmbH, Molecular Links Sachsen-Anhalt, Universitaetsplatz 2, D-39106 Magdeburg, Germany

Thomas J. Jönsson  
Center for Structural Biology, Department of Biochemistry, Wake Forest University School of Medicine, Winston-Salem, North Carolina, 27157, USA

P. Andrew Karplus  
Department of Biochemistry and Biophysics, Oregon State University, Corvallis, OR 97331

Bernard Knoops

Université catholique de Louvain, Institut des Sciences de la Vie (ISV), Laboratory of Cell Biology, Place Croix du Sud, 5, 1348 Louvain-la-Neuve Belgium

Luise R. Krauth-Siegel

Biochemie-Zentrum der Universität Heidelberg, Im Neuenheimer Feld 504, D-69120, Heidelberg, Germany

J. Gordon Lindsay

Division of Biochemistry and Molecular Biology, Davidson Building, Institute of Biomedical and Life Sciences, University of Glasgow, Glasgow G12 8QQ, UK

Eléonore Loumaye

Université catholique de Louvain, Institut des Sciences de la Vie (ISV), Laboratory of Cell Biology, Place Croix du Sud, 5, 1348 Louvain-la-Neuve Belgium

W. Todd Lowther

Center for Structural Biology, Department of Biochemistry, Wake Forest University School of Medicine, Winston-Salem, North Carolina, 27157, USA

Yefim Manevich

Institute for Environmental Medicine, University of Pennsylvania. Philadelphia, PA 19104, USA

Skorn Mongkolsuk

Laboratory of Biotechnology, Chulabhorn Research Institute, Lak Si, Bangkok 10210, and Department of Biotechnology, Faculty of Science, Mahidol University, Bangkok 10400, Thailand

Brian A. Morgan

Institute of Cell and Molecular Biosciences, Faculty of Medical Sciences, Newcastle University, Newcastle upon Tyne, NE2 4HH, UK

Youichi Niimura

Department of Bioscience, Tokyo University of Agriculture, Tokyo Japan

Shinzo Oikawa

Asubio Pharma Co. Ltd.

Research park, Institute of Integrated Medical Research Keio University School of Medicine, Tokyo, Japan

Leslie B. Poole

Department of Biochemistry, Center for Structural Biology, BGTC, Wake Forest University School of Medicine, Winston-Salem, NC 27157, USA

Rafael Radi

Departamento de Bioquímica, Center for Free Radical and Biomedical Research, Facultad de Medicina, Universidad de la República, 11800, Montevideo, Uruguay

Stefan Rahlfs

Interdisciplinary Research Center, Justus Liebig University, Heinrich-Buff-Ring 26–32, D-35392 Giessen, Germany

Tanja Schlecker

Biochemie-Zentrum der Universität Heidelberg, Im Neuenheimer Feld 504, D-69120, Heidelberg, Germany

Bruno Schremmer

Institute for Environmental Medicine, University of Pennsylvania, Philadelphia, PA 19104, USA

Leonor Thomson

Center for Free Radical and Biomedical Research, Facultad de Medicina, Universidad de la República, 11800 Montevideo, Uruguay, and Instituto de Química Biológica, Facultad de Ciencias, Universidad de la República, 11400 Montevideo, Uruguay

Madia Trujillo

Departamento de Bioquímica, Center for Free Radical and Biomedical Research, Facultad de Medicina, Universidad de la República, 11800 Montevideo, Uruguay

Valérie Van der Eecken

Université catholique de Louvain, Institut des Sciences de la Vie (ISV), Laboratory of Cell Biology, Place Croix du Sud, 5, 1348 Louvain-la-Neuve Belgium

Elizabeth A. Veal

Institute of Cell and Molecular Biosciences, Faculty of Medical Sciences, Newcastle University, Newcastle upon Tyne, NE2 4HH, UK

Toru Yanagawa

Majors of Medical Sciences, Graduate School of Comprehensive Human Sciences, University of Tsukuba, Tsukuba, Ibaraki, 305–8575 Japan

## PREFACE

A volume within the *Subcellular Biochemistry* series is an appropriate setting for the first multi-author book devoted to the new family of antioxidant and cell signalling proteins, the *peroxiredoxins*. Within the antioxidant and cell signalling fields, even the existence of the peroxiredoxins has yet to be appreciated by many; with this book we aim to rectify this situation. We have tried to select diverse chapter topics to cover relevant aspects of the subject and to persuade knowledgeable authors to contribute a manuscript. As almost inevitable, a few authors let us down by failing to respond, others could not submit a manuscript in time for personal reasons. These unfortunately were two of the pioneers, Earl Stadtman and Sue Goo Rhee, but we appreciate that they communicated a lot of details that helped us to reconstruct the early phase of peroxiredoxin enzymology. We have thus compiled a book that competently covers the peroxiredoxin field from its beginnings through to currently relevant topics.

In the introductory Chapter 1 we provide a short historical survey of the subject, based upon the early structural and enzymic studies on peroxiredoxins, and then lead into some of our current personal interests, such as the likely continuing contribution of transmission electron microscopy (TEM) for the study of high molecular mass peroxiredoxin complexes and the association of peroxiredoxins with other proteins, and the targeting of drugs against microbial peroxiredoxins, as future therapeutic approaches. The subsequent chapters fall into roughly two sections, the first group dealing with the fundamental structural and enzymic aspects, followed by chapters dealing with the peroxiredoxins within defined organisms and biological systems.

In Chapter 2, Bernard Knoops and his colleagues provide a survey on the evolution of the peroxiredoxins, followed in Chapter 3 by a structural survey of these molecules, from Andrew Karplus and Andrea Hall. In Chapter 4, Leslie Poole discusses the catalytic mechanism of the peroxiredoxins, leading to a consideration in Chapter 5 of the kinetics of the peroxiredoxins and their role in the decomposition of peroxynitrite, from Madia Trujillo and colleagues, and the peroxiredoxin repair proteins are dealt with by Thomas Jönsson and Todd Lowther, in Chapter 6.

Moving to the physiological systems-based considerations, Chapter 7, on the peroxiredoxins in bacterial antioxidant defense is written by James Dubbs and Skorn Mongkolsuk, and the NADH oxidase-Prx system in *Amphibacillus xylanus*, by Youichi Niimura, in Chapter 8. Then, in Chapter 9, Timo Jaeger discusses the peroxiredoxin systems in mycobacteria. In Chapter 10 Marcel Deponte and colleagues present the peroxiredoxin systems of protozoal parasites in general,

and Luise Krauth-Siegel and colleagues focus on the tyrypanothione system of kinetoplasts in Chapter 11. Brian Moragan and Elizabeth Veal present the functions of typical 2-Cys peroxiredoxins in yeast, in Chapter 12. The dual function of plant peroxiredoxins in antioxidant defence and redox signalling is presented by Karl-Josef Dietz in Chapter 13 and Zhenbo Cao, and colleagues deal with the mitochondrial peroxiredoxins in Chapter 14. Brunno Schremmer and colleagues in Chapter 15 deal with peroxiredoxins in the lung, with emphasis upon peroxiredoxin VI, and in Chapter 16 Isabelle Donnay and Bernard Knoops present an assessment of the involvement of the peroxiredoxins in gametogenesis and embryo development. In Chapter 17, Fumiyuki Hattori and Shinzo Oikawa deal with the significant involvement of the peroxiredoxins in the central nervous system, and in Chapter 18 Tetsuro Ishii and Toru Yanagihawa write on the stress-induced peroxiredoxins.

We hope that this compilation will be of interest and use to those on the periphery of the peroxiredoxin field, dealing with other antioxidant systems and cell signalling mechanisms, as well as those who are currently directly concerned with peroxiredoxin structure and function. As with other rapidly expanding topics, it is difficult to keep fully abreast of this field of study; nevertheless, this book provides a comprehensive present-day account of the peroxiredoxin subject, which will undoubtedly move forward to more detailed understandings and into new areas of significance.

*Leopold Flohé and J. Robin Harris*

January, 2007.

## CHAPTER 1

### INTRODUCTION

#### *History of the peroxiredoxins and topical perspectives*

LEOPOLD FLOHÉ<sup>1</sup> AND J. ROBIN HARRIS<sup>2</sup>

<sup>1</sup>MOLISA GmbH, Universitätsplatz 2, D-39106 Magdeburg, Germany

<sup>2</sup>Institute of Zoology, University of Mainz, D-55099 Mainz, Germany

**Abstract:** We have surveyed the early biochemical, structural and enzymatic studies on the peroxiredoxin family, within the broad context of the other chapters included within this book. Both the antioxidant defence and peroxide-linked cell signalling roles of the peroxiredoxins are introduced. The possible membrane-association of certain peroxiredoxins is assessed and the structural characterization of the peroxiredoxins by electron microscopy is given some emphasis here. The important contribution of X-ray crystallographic studies to the understanding of peroxiredoxin structure is given due attention. Finally, some medical perspectives are introduced, with emphasis upon the understanding of the microbial peroxiredoxins as possible future drug targets

**Keywords:** Peroxiredoxin, (Prx), Prx discovery, Prx structure, Prx function, Antioxidant defence

### 1. FROM EARLY DISCOVERIES TO THE EMERGENCE OF AN UBIQUITOUS PROTEIN FAMILY

As with many enzyme families, for the peroxiredoxins the discovery, structural and biochemical characterization of a protein with unknown function preceded the assignment of enzymatic activity. Thus, the single torus protein/torin, a decameric ring-like protein complex isolated from human erythrocytes, was first revealed by transmission electron microscopy (TEM) (Harris, 1968; Harris, 1969). The native sedimentation coefficient of torin was determined as  $\sim 11S$  (Harris, 1971), the subunit mass by SDS-PAGE as  $\sim 20kDa$  (Harris and Naeem, 1978) and the isoelectric point (pI) as  $\sim pH 4.8$  (Harris, 1980). Torin, also characterized as the erythrocyte membrane Band 8 protein, is now known to be identical to the erythrocyte peroxiredoxin II. Some confusion was exhibited in these early studies, because of the co-isolation of a hollow cylindrical protein complex from erythrocytes, now known to be the 20S proteasome. Indeed, this confusion was further perpetuated in the literature by the isolation from bovine mitochondria of a protein complex



that spontaneously formed hollow cylinders and longer tubular stacks, from a ring-like native protein containing a  $\sim 24$ kDa subunit (Kato *et al.*, 1985). It eventually emerged that this protein corresponds to stacked SP-22 molecules, initially defined as a substrate for the mitochondrial ATP-dependent protease (Watabe *et al.*, 1997), but now known as the mitochondrial thioredoxin peroxidase or PrxIII (Gourlay *et al.*, 2003). In general, the terminology and abbreviations to be encountered within the early peroxiredoxin literature are extremely varied, and will be covered here for the sake of historical accuracy and completeness, rather than a deliberate attempt to further confuse the reader, *see* Table 1 (modified from Wood *et al.*, 2003).

In 1989, the murine erythroleukemic MER5 housekeeping gene was defined (Yamamoto *et al.*, 1989) and subsequently an amino acid sequence comparison of the erythrocyte torin revealed homology with the MER5 gene product (JRH, unpublished data). At about the same time others found relevant protein homologies. Early in the 1990s, Chae and colleagues (Chae *et al.*, 1993; Chae and Rhee, 1994; Chae *et al.*, 1994a,b; Lim *et al.*, 1993) cloned and sequenced the gene of Earl Stadtman's thiol-specific antioxidant protein (TSA) from *Saccharomyces cerevisiae* (Kim *et al.*, 1988) and thereby established the homology with the C22 component alkyl hydroperoxide reductase (AhpC) of *Salmonella typhimurium* (Tartaglia *et al.*, 1990) and other bacteria, immediately suggestive of the existence of a large family of proteins. These workers also extended their TSA work to human brain and erythrocytes (Chae *et al.*, 1994b; Lim *et al.*, 1994a, 1994b), thus bridging the gap to the peroxiredoxins of higher eukaryotes, which lead to the widespread use of the terms thiol-specific antioxidant protein (TSA), antioxidant protein (AOP) or protector protein (PRP (Chae *et al.*, 1994b, Chae and Rhee, 1994; Rabilloud *et al.*, 1995). At much the same time the term TPx for either thioredoxin-dependent peroxide reductase or thiol peroxidase was introduced, a terminology that paralleled discovery of the peroxidase nature of these proteins, which had first been established for the bacterial enzymes (Tartaglia *et al.*, 1990; *see* below). But since the precise enzymatic mechanism by which these proteins exerted their "antioxidant" function still remained unclear, a bewildering terminology emerged that described the peroxiredoxins according to source of isolation or presumed biological role, e. g., erythroleukemic heme-binding protein 23 (HBP23), macrophage 23-kDa stress protein (MP23), natural killer-enhancing factor (NKEF) (Hungyi *et al.*, 1997; Shau *et al.*, 1997), plant antioxidant protein (BAS1), osteoblastic specific factor (OSF-3) (Kawai *et al.*, 1994), porcine erythrocyte NKEF-B (Schröder *et al.*, 1998) which is, in fact, equivalent to TPx-B/PrxII and calpromotin (Kristensen *et al.*, 1999) (*see* Table 1).

The term *peroxiredoxin* was first introduced by Chae *et al.* (1994b). It was coined to describe a family of redox-active proteins that are homologous by sequence and explicitly not to characterize these proteins in terms of a defined reaction or substrate specificity (Sue Goo Rhee, personal communication), which turned out to be a wise decision in view of the diversity of peroxiredoxin-catalysed reactions. The term became widely accepted in 1995 (Immenschuh *et al.*, 1995; Iwahara *et al.*, 1995), although it was sometimes slightly modified to peroxidoxin (Rabilloud, 1995), and

Table 1. Six classes of the proxiredoxins (Prxs) from mammals (modified from Wood et al., 2003)

Prx subtype	PrxI (2-Cys)	PrxII (2-Cys) TYPICAL 2-CYS	PrxIII (2-Cys)	PrxIV (2-Cys)	PrxV ATYPICAL 2-CYS	PrxVI (1-Cys) 1-CYS
Previous nomenclature	TPx-A NKEF A MSP23 OSF-3 HBP23 PAG	TPx-B NKEF B PRP Calpromotin Torin Band-8 TSA	AOP-1 SP22 MER5	AOE372 TRANK	AOEB166 PMP20 AOPP Alu corepressor 1	ORF06 LTW4 AOP2 NSGPx AiPLA2 p67phox binding protein
Polypeptide length from human cDNA	199 aa	198 aa	256 aa (cleaved at 63–64)*	271 aa (cleaved at 36–37)*	214 aa (cleaved at 52–53)*	224 aa
Human chromosomal location	1q34.1	19p13.2	10q25–q26	10p22.11	11q13	1q25.1
Cellular location	Cytosol, Nucleus	Cytosol, Membrane	Mitochondria	Cytosol, Golgi, Secreted, Membrane	Mitochondria, Peroxisome, Cytosol	Cytosol
Monomeric Mass from human cDNA	22110Da	21892Da	27693Da (21468Da*)	30540Da	22026Da (21468Da*)	25035Da
3-D Structure	1QO2	IQMV	IZYE	N/A	1HD2, 1OC3, 1H40	PRX1
Swiss-Prot /TrEMBL	PRDX1_HUMAN Q06830	PRDX2_HUMAN P32119	PRDX3_HUMAN P30048	PRDX4_HUMAN Q13162	PRDX5_HUMAN P30044	PRDX6_HUMAN P30041
Interactions with proteins and other ligands	c-Abi Presenilin-1 Heme Thioredoxin Macrophage migration inhibitory factor Cyclophilin c-Myc	Protein 7.2b (stomatin) Presenilin-1 Erythrocyte Membrane Thioredoxin Cyclophilin	Cyclophilin Abrin A-chain ATP-dependent protease Thioredoxin	Heparin Cyclophilin Membrane (testis) Thioredoxin	DNA Cyclophilin Thioredoxin	Cyclophilin p67phox $\pi$ GST

\* Post-translationally processed

a year later the word peroxiredoxin (Prx) first appeared in the title of a publication by Stacy *et al.* (1996) and thereafter became widely used (*e.g.* Lim *et al.*, 1998). The basic classification of the six mammalian types of peroxiredoxins (Table 1) can be extended slightly to include diverse members of the ubiquitous peroxiredoxin family.

The typical and atypical 2-Cys peroxiredoxins and the 1-Cys peroxiredoxin terminology underly the overall classification, which now extends through many organisms, even to the *Archaea* (Mizohata *et al.*, 2005).

Through the early years, as this field of study rapidly expanded, the diverse terms for the antioxidant proteins have continued to be used alongside *peroxiredoxin* and, for good reasons, new ones have been, and likely will continue to be, introduced. Peroxiredoxin being a category of molecular taxonomy only, conventional enzymological names have to be used to complement the taxonomical classification of a particular peroxiredoxin, as soon as its enzymatic activity has been elucidated. Typical examples are “alkylhydroperoxide reductase” (Ahp; systematically: NAD(P)H : hydroperoxide oxidoreductase) for the majority of bacterial 2-Cys peroxiredoxins, “thioredoxin peroxidase” (TPx or TrxPx; thioredoxin : hydroperoxide oxidoreductase) for some bacterial and many eukaryotic 2-Cys peroxiredoxins and “tryparedoxin peroxidase” (TXNPx; tryparedoxin : hydroperoxide oxidoreductase) for the typical 2-Cys peroxiredoxins of kinetoplasts.

## 2. DISCOVERY OF THE PEROXIDASE ACTIVITY OF PEROXIREDOXINS

As is evident from the above, a common enzymatic nature of the peroxiredoxins did not emerge for quite a while and has not yet been established for all members of the family. As a rule, however, peroxiredoxins are now considered to be peroxidases.

The first essentially correct assignment of an enzymatic activity to a peroxiredoxin system was that of an alkyl hydroperoxide reductase to the *ahp* gene product of enterobacteria. Searching for new tester strains that specifically responded to oxidants with increased mutation rates in the classical Ames test, an oxyR-regulated gene cluster was identified that encoded the alkyl hydroperoxide reductase consisting of two co-purifying proteins, AhpC and AhpF (Christman *et al.*, 1989; Jacobson *et al.*, 1989). Sequencing of the *ahp* locus, however, led to the erroneous assignment of the peroxidase activity to AhpF, which belongs to the family of flavin-containing disulfide reductases (Tartaglia *et al.*, 1990). Proteins homologous to the actual peroxidase component, AhpC, were not detected due to sequencing errors, and thus it was left to Chae *et al.* (1994b) to bridge the gap between the bacterial AhpCs, yeast TSA, and the mammalian peroxiredoxins.

Initially, the enzymatic nature of yeast TSA was not clarified. Originally, yeast TSA was discovered in Earl Stadtman’s laboratory as a protein that protected glutamine synthetase against oxidative damage exerted by a free radical-producing system composed of iron, DTT and oxygen (Kim *et al.*, 1988). Since the protein seemingly acted without any co-substrate and did not exhibit superoxide dismutase

or catalase activity, it was presumed to simply scavenge oxygen- or sulphur-centred radicals. Nevertheless, a vague suspicion that it might be a peroxidase working with thiols as reductants emerged. As early as 1991, Earl Stadtman, at a meeting at the Lake Starnberg, Germany, asked one of us (LF) to confidentially screen the newly established TSA sequence for homology with glutathione peroxidases, which, of course, was not found. However, homology was subsequently detected, once PSI-blast became available in the mid-1990s, and enabled the detection of the TRX fold within both classes. Superposition of the common TRX fold suggested that the peroxidatic cysteine in Prx might coincide with the Cys32 in TRX and the seleno-Cys of GPX (*see* Schröder and Ponting, 1998).

When the homology between TSA and AhpC became evident, and also that AhpC could substitute for TSA in the glutamine synthetase protection assay (Chae *et al.*, 1994b), the idea that TSA might be also be a peroxidase was straight forward and, within the same year, thioredoxin was identified as the physiological reductant of TSA (Chae *et al.*, 1994a). Cha and Kim (1995) firmed-up the enzymological significance of TPx in human erythrocytes, in relation to the thioredoxin/thioredoxin reductase system. In retrospect, the confusing observation that the protein, now renamed as thioredoxin peroxidase, seemed to act without any reductant was easily explained. DTT adopts multiple roles in the glutamine synthetase protection assay: It is the source of H<sub>2</sub>O<sub>2</sub> due to iron-catalyzed autoxidation, it reduces Fe<sup>3+</sup> to Fe<sup>2+</sup> and thus helps to generate destructive OH radicals from H<sub>2</sub>O<sub>2</sub> and simultaneously serves as an artificial reductant of the peroxidase (Netto *et al.*, 1996).

For a third time, the peroxidase nature of peroxiredoxins was *rediscovered* during the attempts to elucidate the peroxide detoxifying system in trypanosomatids. These parasites had been reported to lack any of the canonical peroxidases such as catalase or selenium-type glutathione peroxidases (Fairlamb and Cerami, 1992). Instead, they had been shown to use the bis-(glutathionyl) conjugate of glutathione, trypanothione, for enzymatic hydroperoxide reduction (Henderson *et al.*, 1987). The postulated “trypanothione peroxidase” was never isolated and finally Docampo’s group concluded that the trypanothione-dependent H<sub>2</sub>O<sub>2</sub> reduction in trypanosomatids was likely to be a non-enzymatic process (Carnieri *et al.*, 1993). Driven by the firm believe that nature does not rely on non-enzymatic processes in pivotal tasks, Flohé’s team decided to chase the non-existing enzyme in the mid-1990s. The first approach, PCR-based gene fishing by means of probes designed from conserved regions of the glutathione peroxidase family, failed, while a more conventional strategy soon seemed to yield success: A protein with a size of 21 kDa was isolated from the model organism *Crithidia fasciculata* (“Cf 21”) that displayed trypanothione peroxidase activity, when a crude preparation of trypanothione reductase was used to monitor the purification. Also, partial sequencing of Cf 21 revealed clear homology to yeast TSA that had meanwhile been shown to be a peroxidase. When the purification scheme was repeated with well-documented reagents, the very same protein was obtained, but then showed no trace of trypanothione peroxidase activity. The mystery was finally unravelled by purification of a second protein (“Cf 16”) from the trypanothione reductase preparation that was used for the

pilot experiments. Cf 16 turned out to be a remote relative of thioredoxin and was therefore termed tryparedoxin (TXN). It proved to be the protein that reacts with trypanothione (Gommel *et al.*, 1997; Nogoceke *et al.*, 1997) and in its reduced form fuels the TSA-related Cf 21 which, therefore, is not a trypanothione peroxidase, but a tryparedoxin peroxidase (TXNPx). The unique cascade of redox reactions to cope with hydroperoxides, as discovered in *Crithidia* (Nogoceke *et al.*, 1997), was later shown to operate in all pathogenic *Trypanosoma* and *Leishmania* species (Lüdemann *et al.*, 1998; Castro *et al.*, 2002; Levick *et al.*, 1998; Lopez *et al.*, 2000; Flohé *et al.*, 2002; Krauth-Siegel *et al.*, 2003) and different Prx-linked peroxidase systems were discovered in the mitochondria and cytosol of these parasites (Wilkinson *et al.*, 2000; Tetaud *et al.*, 2001; Castro *et al.*, 2002) (see also Chapter 8).

A common feature of the Prx-type peroxidases mentioned so far is that they use proteins as reductants, that are characterized by CXXC motifs that are pivotal to the redox process, be it the CGPC motif in Trx (Chae *et al.*, 1994a), the CPPC in TXN (Budde *et al.*, 2003; Nogoceke *et al.*, 1997), the N-terminal CHNC motif in AhpF of *Salmonella* (Reynolds and Poole, 2001) or the CSHC motif of AhpD from *Mycobacterium tuberculosis* (Bryk *et al.*, 2002). This also appears to hold true for all typical 2-Cys-Prxs and some atypical 2-Cys-Prxs (Baker and Poole, 2003; Jaeger *et al.*, 2004). The donor substrate specificity of most of the 1-Cys-Prxs, however, remains to be determined. Only exceptionally has thioredoxin been found to react with any of the 1-Cys Prxs (Pedrajas *et al.*, 2000). Instead, a glutathione peroxidase activity has been reported for human PrxVI (Fisher *et al.*, 1999), debated and reconfirmed (Ralat *et al.*, 2006). The glutathione peroxidase activity of this 1-Cys Prx requires the participation of a  $\pi$ -glutathione S-transferase which suggests a very special case of functional synergy between these two proteins (Manevitch *et al.*, 2004) that can not likely be applied to other 1-Cys Prxs. Whenever tested, 1-Cys Prxs have, however, been shown to display antioxidant activity in the presence of the non-physiological dithiol DTT and thus may also be suspected to be thiol-dependent peroxidases. (See also Note added in proof on p.25)

The first proposal as to how a protein without any prosthetic group or reactive hetero-atom acts as a peroxidase with reasonable rates was presented by Chae *et al.* (1994c). By site-directed mutagenesis cysteine 47 in yeast TSH was shown to be absolutely essential to its peroxidase activity and is therefore called the “peroxidatic cysteine”, C<sub>p</sub>. Based on this observation, this cysteine residue was postulated to be oxidized by the peroxide substrate to a sulfenic acid. That this oxidation state is indeed formed during Prx catalysis was unequivocally established by Leslie Poole’s group by scavenging the unstable intermediate and MS analysis of the reaction products in bacterial AhpC and TPx (Baker and Poole, 2003; Ellis and Poole, 1997; Poole and Ellis, 2002). In this respect, the reaction mechanism turned out to be similar to that of the non-homologous GPx-type proteins, in which a reactive chalcogen, selenium or sulphur, is presumed to be oxidized by a hydroperoxide to a selenenic or sulfenic acid, respectively (Flohé, 1989). In fact, the analogy of GPx and Prx catalysis is further corroborated by the finding that in a strange Prx of *Eubacterium acidamidophilum* the C<sub>p</sub> is replaced by

selenocysteine (Söhling *et al.*, 2001). Unlike the selenium-containing GPxs, where the reducing substrate, typically glutathione, immediately attacks the selenenic acid, the analogous reactive intermediate of the yeast thioredoxin peroxidase appeared to be inaccessible to the physiological reductant. As again corroborated by site-directed mutagenesis, its oxidized Cys47 had first to form a disulfide bridge to Cys170 of an inversely oriented (domain-swapped) second subunit, before the oxidized enzyme could be reduced by thioredoxin (Chae *et al.*, 1994c). The distally conserved cysteine is therefore called resolving cysteine ( $C_R$ ). The sequence of catalytic steps thus is: i) oxidation of the N-terminally conserved “peroxidatic” cysteine ( $C_P$ ) to a sulfenic acid, ii) conservation of the oxidation equivalents in form of an internal disulfide bond and iii) reduction of the latter through attack by the reducing substrate on the conserved “resolving” cysteine ( $C_R$ ). This catalytic scheme has meanwhile been accepted for all 2-Cys Prxs. As in many enzymes (Marianayagam *et al.*, 2004) the active sites of these peroxidases are built up by dimers, and dimerization appears to be a characteristic feature of almost the entire peroxiredoxin family. It is obligatory for typical 2-Cys Prxs, which tend to form higher aggregates with 10 or more reaction centres (see below), but is equally seen with the functionally monomeric 1-Cys Prxs or atypical 2-Cys Prxs.

### 3. ANTIOXIDANT DEFENCE

Characterisation of a family of enzymes as peroxidases almost automatically triggers the idea that they are in charge of defence against oxidative stress. This is not necessarily justified, and many examples of better known peroxidase families may be quoted to highlight that the ability to reduce hydroperoxides is used physiologically for different purposes. In fact, most of the known heme-type peroxidases just use the substrate  $H_2O_2$  to achieve specific syntheses that require oxidation equivalents, and similarly the phospholipid hydroperoxide glutathione peroxidase (GPx4) makes use of hydroperoxides to cross-link proteins, which is a process indispensable for sperm maturation in mammals (Ursini *et al.*, 1999).

However, ever since the production of an oxygen-rich atmosphere early in biological evolution, living organisms have of necessity developed protective systems to combat the powerful damaging effects of oxidation. Peroxides (hydrogen peroxide, alkyl hydroperoxides and peroxyxynitrite) and oxygen- and nitrogen-centred radicals derived there from (ROS or NOS, respectively) have the potential to chemically damage carbohydrates, proteins, lipids and nucleic acids. Being a kind of unavoidable hazard in aerobic life, ROS and NOS are further “misused” to build up the armamentarium of the steady battle between pathogenic micro-organisms and their victims. In this context, the formation of the superoxide radical is often complicated by generation of NO and lipid hydroperoxides by NO synthases and lipoxygenases, respectively. Inevitably, this scenario affords efficient systems of self-protection and defence against the chemical attack from outside. The required efficiency is best achieved by catalysis, and accordingly the biological defence systems are commonly composed of enzymes.

The first line of defence appears to be common to all organisms with the exception of some anaerobes (Jenney *et al.*, 1999). One or the other type of superoxide dismutase (SOD) eliminates the superoxide radical anion that arises from autooxidation processes, leakage of the respiratory chain or the respiratory burst during the innate immune response. One of the products of the SOD reaction,  $H_2O_2$ , has to be removed by peroxidases, since it is cytotoxic as such and may generate even more drastic oxidants such as hypochloric acid or the hydroxyl radical which destroys most of the cellular components with diffusion-limited rate constants. Nature has invented at least three distinct families of proteins for this job: the heme-type peroxidases, the glutathione peroxidases (Flohé and Brigelius-Flohé, 2006), and the peroxiredoxins (Hofmann *et al.*, 2002), and such proteins and their supply devices have been combined during evolution, with considerable complexity, to provide species-specific antioxidant defence systems (*see* Chapters 6–8 and 10–12). The peroxidase family known best, the heme proteins, appears to be least suited to cope with the demand, since they typically reduce only  $H_2O_2$  at sufficient rates; the glutathione peroxidases act on a large variety of hydroperoxides and do so with extreme velocity when they contain selenocysteine in their active site; the peroxiredoxins, which almost exclusively work with sulphur catalysis, are less efficient, but share with glutathione peroxidases the broad substrate specificity that may cover hydroperoxides of complex lipids and even peroxynitrite (Bryk *et al.*, 2000; Hofmann *et al.*, 2002; Jaeger *et al.*, 2004; Trujillo *et al.*, 2004). In many micro-organisms, which often lack the more efficient heme- and selenoperoxidases, peroxiredoxins appear to be the predominant, if not the only peroxide-detoxifying enzymes. In vertebrates, where the peroxiredoxins have to compete with a variety of faster peroxidases, more specific biological roles than defence against generalized oxidative stress are likely to be involved (Hofmann *et al.*, 2002). In some mammalian tissues, however, peroxiredoxins are sufficiently abundant to contribute to defence against oxidative stress (Lee *et al.*, 2003).

#### 4. PEROXIDE-LINKED REDOX SIGNALLING

Modification of proteins by redox processes has for long been discussed as a concept of regulating cellular events. Starting in 1965 Pontremoli and Horrecker (Nakashima *et al.*, 1969; Pontremoli *et al.*, 1965; Pontremoli *et al.*, 1967) reported on the activation of fructose diphosphatase and, in consequence, gluconeogenesis by physiological disulfides such as cystamine and oxidized CoA, and later hydroperoxide exposure was shown to induce gluconeogenesis in perfused rat liver (Sies *et al.*, 1972). Sulfhydryl oxidation was also implicated in the regulation of glucose-6-phosphate dehydrogenase (Jacob and Jandl, 1966) and other enzymes in the 1960s (reviewed by Brigelius, 1985). In the 1970s, signal-transduction by hormones was firmly linked to redox events. For example, the action of insulin was related to thiol oxidation (Czech *et al.*, 1974), and  $H_2O_2$  was suspected to be the second messenger in transduction of the insulin signal (May and de Haen, 1979a; May and de Haen, 1979b; Mukherjee and Lynn, 1977). But these early hints were overshadowed by

the regulatory principle of protein phosphorylation and dephosphorylation in the following decades (Fischer, 1997). Interestingly, Aslan and Ozben (2003) showed that the phosphorylation-mediated signalling cascade of insulin could be enhanced by vanadate plus  $\text{H}_2\text{O}_2$  (Heffetz *et al.*, 1990) or by largely equivalent peroxovanadate complexes (Posner *et al.*, 1994), a tool that is now widely used to inhibit a variety of protein phosphatases. The efficacy of peroxovanadate, which is consistently better than that of vanadate itself, again reveals the redox-sensitivity of many phosphatases, and this phenomenon has meanwhile been accepted as an important mechanism to modulate many of the phosphorylation cascades (Rhee *et al.*, 2003). Moreover, like insulin, other hormones, cytokines and growth factors themselves proved to induce the formation of  $\text{O}_2^-$ ,  $\text{H}_2\text{O}_2$  or lipid hydroperoxides, which modulate their signalling cascades (Aslan and Ozben, 2003; Eling and Glasgow, 1994; Flohé *et al.*, 1997; Griendling and Ushio-Fukai, 2000; Maulik and Das, 2002; Radeke *et al.*, 1990; Zhu and Bunn, 1999)

Oxidative inactivation of protein phosphatases turned out to be only one of the possible ways to interfere with signalling (Rhee *et al.*, 2003). Interesting alternative mechanisms of redox signalling are, *e.g.*, inhibitory binding of reduced, but not oxidized thioredoxin to the apoptosis signal regulating kinase-1 (ASK1) (Saitoh *et al.*, 1998), facilitating DNA binding of NF $\kappa$ B by reduced thioredoxin (Hirota *et al.*, 1999), and the oxidation of pivotal cysteines in Keap1 that results in nuclear translocation and activation of the transcription factor Nfr2 (Banning *et al.*, 2005; Itoh *et al.*, 1999).

Through the past decade the link between generation of hydrogen peroxide, lipoxygenases products or NOS and signal transduction was firmly established (Finkel, 2000), and Rhee (1999) advanced the concept that the peroxiredoxins could provide a sensor mechanism for  $\text{H}_2\text{O}_2$  levels, *via* a reversible active site cysteine oxidation to a sulphinic acid that in turn modulates the local concentration of cytokine- or growth factor-induced  $\text{H}_2\text{O}_2$  (Rhee *et al.*, 2005; Vivancos *et al.*, 2005). The reduced sensitivity of prokaryotic *versus* eukaryotic 2-Cys peroxiredoxins to oxidative inactivation led Wood *et al.* (2003) to propose their “floodgate theory”, based upon structural adaptation that enabled low levels of hydrogen peroxide to be retained during resting metabolism, while higher levels could be utilized, *e.g.*, for stress signal transduction.

Nevertheless, the question as to which of the plethora of available peroxidases regulates a particular cellular event remains a challenging problem. Many of the genetic studies that support a regulatory role of peroxiredoxins have also been performed with glutathione peroxidases with similar results and similar conclusions (for review see Flohé and Brigelius-Flohé, 2006). This is not surprising, since the two families of peroxidases similarly affect the redox balance of the cell. But some observations made with glutathione peroxidases reveal that that it might be too simplistic to expect a meaningful regulation just from the cellular peroxide rise or fall of the redox potential. A moderate overexpression of GPx-4, for instance, abrogated interleukin-1 signalling, while a huge variation in GPx-1 had only a minor effect (Brigelius-Flohé *et al.*, 2004). The molecular basis of this surprising



finding is unclear, but suggests that peroxidase actions go beyond the mere elimination of peroxides. In fact,  $H_2O_2$  is not an ideal regulatory mediator, since it will react promiscuously with any accessible SH group that is dissociated at physiological pH. The reaction products of the peroxidases have a better chance to target proteins specifically. Peroxiredoxins share with glutathione peroxidases the ability to reduce organic hydroperoxides and to thereby create specific effector molecules (Tang *et al.*, 2002). The donor substrate specificity being more pronounced, it may be anticipated that GPx-type peroxidases might preferentially regulate *via* the GSH/GSSG couple and the peroxiredoxins *via* the thioredoxin system. A most appealing idea, however, is that the peroxidases themselves could act as thiol-modifying agents. GPx-3, GPx-4, and all 2-cysteine Prxs so far investigated are known to use protein thiols as donor substrates. The product could be an oxidized protein, as is the case in the reaction with thioredoxin or glutaredoxin, but may also be a peroxidase-modified protein with modified biological activity, if the reacting thiol of the targeted protein is that of an isolated cysteine residue. A few examples of this scheme have so far been reported: In late sperm differentiation GPx-4 reacts this way with itself and other thiol-rich proteins to form the mitochondrial capsule material in the mid-section of spermatozoa (Ursini *et al.*, 1999), and several human Prxs were shown to bind to cyclophilin A, which was associated with increased peroxidase activity (Jäschke *et al.*, 1998; Lee *et al.*, 2001). PrxII was indeed found to be covalently linked to the cyclophilin *via* a disulfide bridge (Lee *et al.*, 2001). Furthermore, in yeasts, several  $H_2O_2$  sensor systems have been defined, such as Sty1 (Veal *et al.*, 2005; Vivancoos *et al.*, 2004) Pap1 (Bozonet *et al.*, 2005) and the Orp1- Yap1 sensor (Toledano *et al.*, 2004). In the latter case the  $H_2O_2$ -oxidized  $C_p$  of a GPx-type protein reacts with, and thereby activates the transcription factor Yap 1, while reversal of this activation requires a thioredoxin. Such peroxide-dependent protein/protein interaction would ideally meet the requirements of a regulatory process in being highly specific, essentially irreversible, but being reversed by a distinct route, thus allowing an independent steering of the forward and backward reaction, as is almost mandatory for regulatory circuits.

It can be anticipated that the significance of this complex aspect of peroxidase function will continue to be explored alongside the more fundamental role in antioxidant defence. The present state of knowledge on Prx-linked regulation is presented in detail in Chapters 12 and 13.

## 5. POSSIBLE MEMBRANE-ASSOCIATION

The association of the protein torin with the cytoplasmic surface of the erythrocyte membrane was implied from the early studies (Harris, 1968). However, this was subsequently qualified, as it was shown that hemolysis of the erythrocyte can produce a large number of small membrane lesions rather than a single large lesion. This creates a natural membrane filter that allows the escape of hemoglobin and small molecules, but selectively entraps higher molecular mass cytosolic molecules, such as torin/PrxII, the soluble p97 Mg-ATPase complex and the 20S proteasome,

which also tend to be at least partially retained during the repeated washings used to produce hemoglobin-free erythrocyte ghosts. Bearing in mind that the erythrocyte PrxII is now known to be the 2nd most abundant erythrocyte cytosolic protein after hemoglobin (Shau and Kim, 1994), the subsequent release of torin following induction of membrane damage to erythrocyte ghosts by freeze-thawing is not surprising. The presence of calcium in the hemolysis and washing buffers does, however, influence the quantity of membrane-bound torin/PrxII (erythrocyte membrane protein Band 8), catalase and other proteins (Allen and Cadman, 1979).

Apart from its antioxidant activity, the erythrocyte PrxII (at that time termed calpromotin) was shown to activate the erythrocyte membrane Ca-dependent potassium (Gardos) channels (Moore *et al.*, 1990, 1991; Moore and Shriver, 1997; Plishker *et al.*, 1986; 1992), apparently through membrane binding. Furthermore, calpromotin was claimed to be involved with the formation of dense erythrocytes in sickle cell anaemia, where a larger quantity of calpromotin was associated with the cytoplasmic surface of the cell membrane of these cells, possibly do to the higher cytoplasmic calcium level (Moore *et al.*, 1997). A conclusive parallel between human erythrocyte calpromotin and the antioxidant protein TSA/PrxII was presented by Kristensen *et al.* (1999). Dimer and higher molecular weight oligomer formation by calpromotin also correlated well with the properties of TSA/PrxII. Additional support for the interaction of human erythrocyte TSA/PrxII with erythrocyte membranes came from the study of Cha *et al.* (2000) who showed that the presence of the C-terminal peptide (Gln-185 to Gln-197) was essential for membrane binding, and this provided evidence for both a soluble and membrane-associated form of the enzyme.

The mitochondrial and chloroplast peroxiredoxins, although clearly localized to these organelles, are soluble proteins rather than membrane-associated proteins, but the neutrophil p29 peroxiredoxin may interact with and protect the phagolysosomal and plasma membrane p67 protein (Leavey *et al.*, 2002). A membrane-bound form of PrxIV has been shown to be involved with acrosome formation during spermiogenesis in rats (Sasagawa *et al.*, 2001) and for *Entamoeba histolytica* a cell surface peroxiredoxin has been shown to protect the organism from oxidant attack (Choi *et al.*, 2005). Nevertheless, it remains to be demonstrated whether or not most other peroxiredoxins associate functionally with cellular membranes; the available evidence suggests that this is generally not the case.

## 6. STRUCTURE

### 6.1. Characterization

Purification and structural characterization of some peroxiredoxins has been direct from tissue or defined cells, but an increasing number of studies have used molecular cloning of peroxiredoxins, often combined with the production of mutants for comparison with the wild-type molecules. The ability to readily perform amino acid sequence comparison has been important for the assessment of homology across

the peroxiredoxin family, with definition of the highly conserved cysteines and the study of mutants has progressively provided information on the structural features essential for enzymatic activity, subunit dimerization and oligomer formation.

## 6.2. Transmission Electron Microscopy

Transmission electron microscopy (TEM) played a useful role in the early structural studies on the peroxiredoxins. The limited TEM resolution achievable in 3D image reconstructions is  $\sim 20$  Å from negative staining, but is currently somewhat better than 10 Å from cryoelectron microscopy of unstained vitrified specimens of protein molecules. For detailed structural studies TEM has been greatly surpassed by higher resolution crystallographic X-ray diffraction analysis (see below). Nevertheless, correlation of a  $\sim 19$  Å resolution 3D reconstruction produced from the negative stain TEM data of the decameric human erythrocyte PrxII with the available 1.7 Å X-ray structure (Harris *et al.*, 2002; Schröder *et al.*, 1999; Schröder *et al.*, 2000) firmly validated the lower resolution TEM data. In instances where the Prx subunit dimer forms an incomplete ring (*i.e.* 4-mer, 6-mer and 8-mer), arc-like images have been detected by TEM, in particular for the cloned 6 His-tagged tryparedoxin peroxidase (JRH and LF, unpublished data).

Whilst the subunit number within the ring-like Prx oligomers has usually been assessed as 10, there have been a few cases where erroneous numbers have been advanced from TEM data, such as eight for the *Aeropyrum peris* TPx (ApTPx; Jeon and Ishikawa, 2003), which was subsequently shown to be 10 by X-ray crystallography (Mizohata *et al.*, 2005). However, the AhpE from *Mycobacterium tuberculosis* does indeed form an octamer (Li *et al.*, 2005). In a converse manner, the mitochondrial SP22/PrxIII was initially thought from TEM data to contain 10 subunits (Gourlay *et al.*, 2003), but was recently shown by X-ray crystallography to contain 12 subunits (Cao *et al.*, 2005).

The ability of TEM to directly provide information on the varying oligomerization state of a peroxiredoxin, together with the higher-order association state of the oligomer (e.g. Jeon and Ishikawa, 2003; Gourlay *et al.*, 2003) remain valid reasons for the continued use of TEM alongside the available biochemical and biophysical techniques used for the study of protein mass.

A comparison of human erythrocyte PrxII decamers and bovine mitochondrial PrxIII dodecamers is shown in Figure 1. The PrxIII has a tendency to associate to form tube-like molecular stacks, a feature not so far observed for any of the Prxs.

Prx association to form a higher-order assembly also exemplified by the ability of the erythrocyte PrxII decamer, which in the presence of PEG and ammonium molybdate can form a regular dodecahedral macromolecular assembly, containing 12 decamers (Figure 2); for details see Meissner *et al.* (2006). Rows of side-to-side linked PrxII decamers and randomly clustered decamers have also been detected under these *in vitro* conditions (*cf* Harris and Scheffler, 2002). An *aggregated* state can be induced by hyperoxidation of PrxI decamers (Schröder and Harris, unpublished data), which can be separated by gel filtration chromatography from any

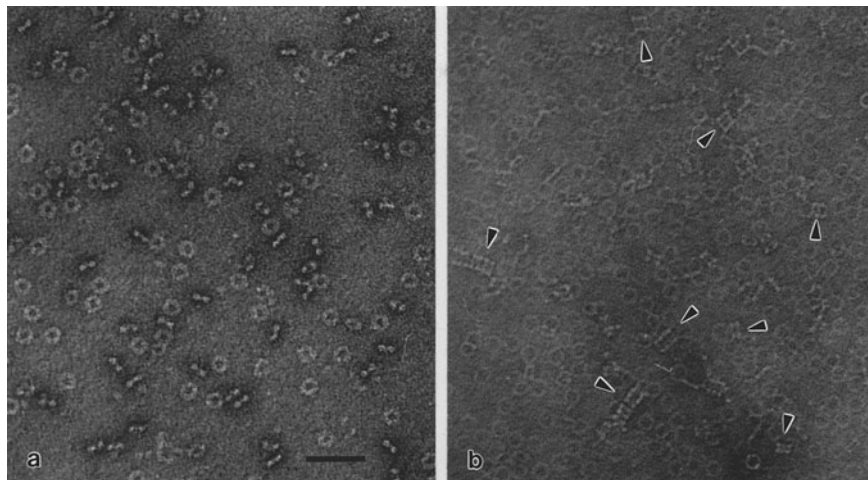

*Figure 1.* Negatively stained TEM images of peroxiredoxins-II and -III. (a) Human erythrocyte PrxII, negatively stained with 2% uranyl acetate. This electron micrograph shows the characteristic ring-like and double-dot images of this decameric molecule, and is essentially equivalent to those included in the first publication showing this protein (Harris, 1969). (b) Mitochondrial PrxIII (SP22), negatively stained with 5% ammonium molybdate, 1% trehalose (Harris and Scheffler, 2002). Again the molecule is revealed as ring-like and double-dot images. Note, however, that the dodecameric PrxIII tends to produce tube-like stacks (arrowheads) and that the central hole of the rings is more pronounced than for PrxII. The scale bar indicates 100nm

remaining single decamers (Figure 3). Similarly, creation of 2-D crystals from the *Thermus aquaticus* AhpC has been assessed by TEM (Figure 4)F4 (*see Harris et al.*, 2006); strangely, other decameric peroxiredoxins failed to form 2-D crystals, although disordered 2-D arrays were produced from erythrocyte PrxII (Harris *et al.*, 2001)

As a word of caution, it must be mentioned that negatively stained TEM specimens do carry with them an element of risk, in that small spherical electron transparent structures can readily be produced from micro-air bubbles attached to hydrophobic regions on the carbon support film, as negative staining artefacts which can readily be confused with images of  $\sim$  spherical protein molecules or protein complexes. Whether or not this was the case for the high molecular mass smooth-surfaced electron transparent particles of oxidized yeast cPrxI produced by Jang *et al.* (2004) is not clear, but it is apparent that these are distinctly different from the loose PrxI decamer aggregates shown in Figure 3 and those produced by oxidized *Trypanosoma brucei brucei* TbTXNPx by Budde *et al.* (2003). The interaction/association of decameric TbTXNPx with other proteins was also monitored by TEM by Budde *et al.* (2003), an aspect of TEM work that is likely to hold considerable future potential, even at the level of the peroxiredoxin subunit or subunit dimer. The formation of filamentous PrxII complexes *in vivo* during H<sub>2</sub>O<sub>2</sub>-dependent cell cycle arrest, revealed by confocal microscopy (Phalen *et al.*, 2006), requires confirmation from future TEM studies.

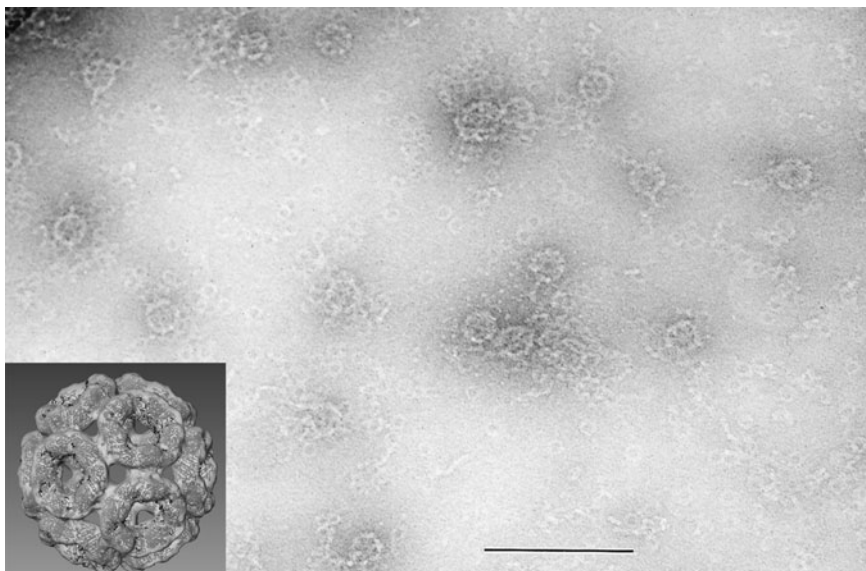

*Figure 2.* Human erythrocyte PrxII following treatment with ammonium molybdate and PEG during the TEM specimen preparation (Meissner *et al.*, 2006). Note the formation of higher-order dodecahedral assemblies, set within a background of individual PrxII decamers and clusters. The inset shows a  $\sim 19$  Å 3D reconstruction of the dodecahedron produced from the TEM data (Meissner *et al.*, 2007), with the 1.7 Å X-ray structure (Schröder *et al.*, 2001) automatically fitted. The scale bar indicates 200 nm

### 6.3. X-ray Crystallography

The first X-ray crystal structure of a peroxiredoxin was for the human peroxidase (hORF6), from which important molecular features were immediately defined (Choi *et al.*, 1998). ORF6 was shown to form a domain-swapped dimer, with the C-terminal domain being used for dimerization and the N-terminal domain was shown to contain a thioredoxin fold, with the cysteine-47 functionally important at the active site. This was followed by the crystal structure of heme-binding protein 23 (HBP23), which again formed a domain swapped dimer (Hirotsu *et al.*, 1999). These workers emphasised the formation of inter-subunit disulfide bonds between the active site cys-52 and cys-173 within the dimer. Although this peroxiredoxin bound both heme and the c-Abl protein tyrosine kinase, the mechanism of this interaction was not determined. The presence of 10 subunits as a characteristic of the 2-Cys and 1-Cys Prx molecules and although implicit from the early TEM work (Harris, 1968, 1969), was confirmed by the X-ray crystallographic studies Schröder *et al.* (1999; 2000) for the erythrocyte PrxII, and by Kitano *et al.* (1999) for *Amphibacillus xylanus* AhpC, together with the fact that the oligomer has five-fold symmetry (*i.e.* 52/D52 point group symmetry) because of the underlying subunit dimerization. Interestingly, the 1-cys peroxiredoxin AhpE from *Mycobacterium tuberculosis* has been shown by X-ray crystallography to form an octamer

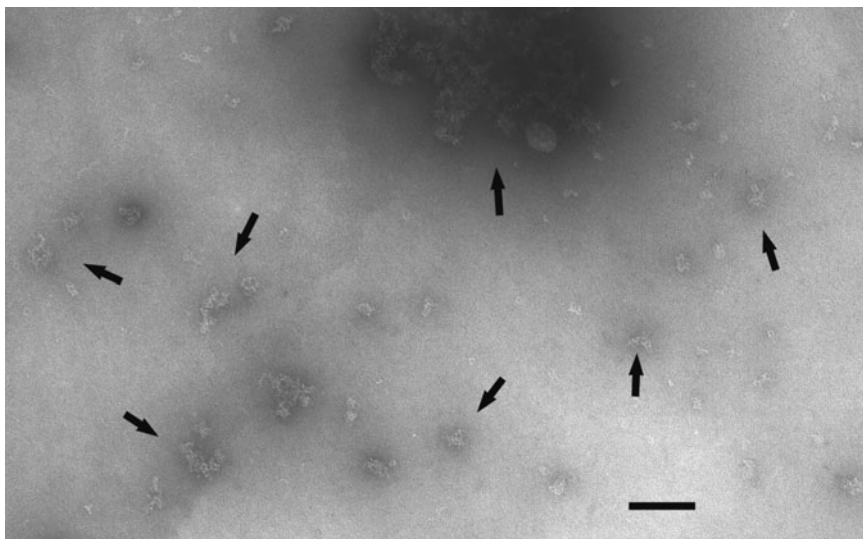

*Figure 3.* The void (excluded) fraction of PrxI treated at pH 8 with 20mM DTT and 2mM H<sub>2</sub>O<sub>2</sub> to produce hyperoxidation, followed by gel filtration (kindly provided by Ewald Schröder). This treatment, which is likely to cause hyperoxidation of Cys-52 and possibly Cys83, produced randomly linked clusters of PrxI decamers (arrows), ranging in size from several hundred molecules (top) to relatively few. Note in all cases that the individual molecules within the clusters can be defined. Relatively few single decamers are present, but there may be some instability within the clusters leading to breakdown in the absence of DTT and H<sub>2</sub>O<sub>2</sub> following gel filtration. The scale bar indicates 200 nm

(Li *et al.*, 2005). However, the 1-Cys peroxiredoxin from *Plasmodium falciparum* forms only the homodimer (Sarma *et al.*, 2005), as does the oxidised form of human PrxV (Evard *et al.*, 2004). Also remarkable is the ring-like dodecamer formed by bovine mitochondrial SP22/PrxIII (Cao *et al.*, 2005), but again with the subunit dimer as a structural feature. However, the human PrxV is anomalous, in that it does not form a dimer (Declercq *et al.*, 2001).

Thus, it can be seen that from approximately the year 2000, the expansion of the available X-ray crystallography data on the peroxiredoxins (wild-type molecules and mutants) has been impressive. This has led to the detailed correlation of oligomerization with oxidation state, and of structure with enzymatic function for most Prx classes (*see* Chapter 3).

## 7. MEDICAL PERSPECTIVES

As outlined above and compiled in detail in Chapters 14 to 18, the mammalian peroxiredoxins might be involved in the regulation of numerous metabolic events such as inflammation, cell cycle regulation, apoptosis or antioxidant defence. The elucidation of their individual roles is likely, therefore, to contribute to a better understanding of human diseases. Already, a link between peroxiredoxins and

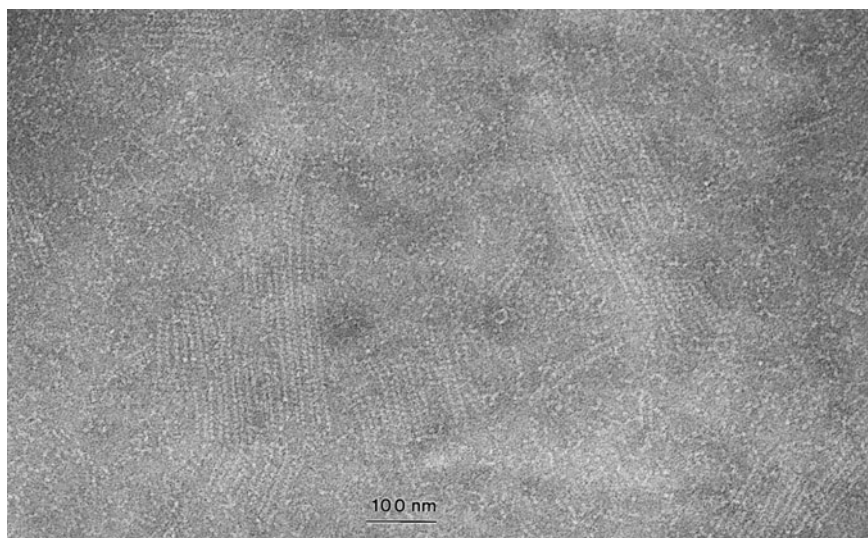

Figure 4. 2-Dimensional crystalline arrays of the decameric 2-Cys peroxiredoxin-II from *Thermus aquaticus* (courtesy of Stephen G. Mayhew), produced when forming negatively stained specimens on holey carbons support films in the presence of ammonium molybdate, trehalose and PEG (Harris and Scheffler, 2002). Note the oblique arrangement of the stacked molecules and compare with PrxIII (Figure 1b) and erythrocyte PrxII in Harris *et al.* (2001)

neurological disorders has been established (Kim *et al.*, 2001; Krapfenbauer *et al.*, 2003; Gao *et al.*, 2005) and also in autoimmune and dermatological disease states. At present, however it appears premature to speculate about any therapeutic interference with the mammalian peroxiredoxin systems, since pertinent knowledge is still too rudimentary.

In contrast, the role of peroxiredoxins in microorganism has become more defined over the last decade. In many pathogens they clearly substitute for the selenoproteins that dominate hydroperoxide metabolism in mammals (Flohé *et al.*, 2000; Jäger and Flohé, 2006). This fundamental difference in strategy to cope with oxidative stress presents a unique chance to selectively compromise the pathogen's viability and virulence by inhibiting its ability to defend itself against the oxidative attack, to which it is inevitably exposed during by the host's innate immune response. In short, shutting down the pathogen's peroxiredoxin system would be likely to expose it unprotected to the arsenal of ROS and NOS that is released *in vivo* as a defence mechanism by the phagocytes of the infected organism. This idea was conceived for the therapy of "hard to treat" infections such as Trypanosomiasis and Leishmaniasis, even at times when the role of their peroxiredoxins in the causative agents had not yet discovered (Fairlamb and Cerami, 1992) and has since become a realistic option, which could be applied to a large variety of infectious diseases (Becker *et al.*, 2003; Fairlamb, 2003; Flohé, 1998; Flohé *et al.*, 1999).

For Trypanosoma and Leishmania species, most enzymes of the trypanothione system including the cytosolic TXNPx, were shown to be of vital importance and thus validated as drug targets (Comini *et al.*, 2004; Dumas *et al.*, 1997; Krieger *et al.*, 2000; Schmidt and Krauth-Siegel, 2002; Tovar *et al.*, 1998a; Tovar *et al.*, 1998b; Wilkinson *et al.*, 2003). In principle, therefore, it would not matter at which level the trypanothione system is blocked. Yet TXNPx itself is not likely to be an ideal drug target, since it might be difficult to hit the parasitic enzyme selectively in view of the closely related human peroxiredoxins. Of the different enzymes that constitute the system, those involved in trypanothione synthesis appear to be the most attractive target, since they are present at low abundance and are unique in sequence (Comini *et al.*, 2005). Furthermore, not only would the antioxidant defence of the parasite in this way be eliminated, but also its DNA synthesis, which in these organisms also depends on trypanothione (Dormeyer *et al.*, 2001).

Similarly, it appears advisable to target the peroxiredoxin supply system in *Mycobacteria* rather than their AhpC or thiol peroxidase, since both are reduced by one or the other thioredoxin (Jaeger *et al.*, 2004). In order to prevent a mutual substitution of the peroxiredoxins or their regenerating thioredoxins, the safest way to block the entire system would be to target the bacterial thioredoxin reductase. An identical approach could be envisaged for fighting *Helicobacter pylori*, whose thiol peroxidase also depends on thioredoxin (Baker *et al.*, 2001; Jaeger and Flohé, 2006).

A more complex situation is faced in the case of malaria. The defence system of *Plasmodium* species comprises peroxidases of two protein families, the GPx- and Prx-type proteins. Surprisingly, however, all these peroxidases require thioredoxin as reductant (Becker *et al.*, 2003; Sztajer *et al.*, 2001). Again, an optimum therapeutic opportunity can therefore be expected by inhibition of thioredoxin reductase. However, the possibility of a mutual substitution of the plasmodial glutathione and thioredoxin systems cannot be excluded. Since the rapid development of resistance against any too-specific a drug could be anticipated, it might thus be wise to target both pathways simultaneously (Jaeger and Flohé, 2006).

In conclusion, the discovery of more or less unique peroxiredoxin systems in pathogenic bacteria or protozoa has opened up an appealing route to search for a novel type of safe and efficacious antibiotics that would meet real medical demands.

## REFERENCES

- Allen, D.W., Cadman, S., 1979, Calcium-induced erythrocyte membrane changes. The role of adsorption of cytosol proteins and proteases. *Biochim. Biophys. Acta* **551**: 1–9.
- Aslan, M., Ozben, T., 2003, Oxidants in receptor tyrosine kinase signal transduction pathways. *Antioxid. Redox Signal* **5**: 781–788.
- Baker, L.M., Poole, L.B., 2003, Catalytic mechanism of thiol peroxidase from *Escherichia coli*. Sulfenic acid formation and overoxidation of essential CYS61. *J. Biol. Chem.* **278**: 9203–9211.
- Baker, L.M., Raudonikiene, A., Hoffman, P.S., Poole, L.B., 2001, Essential thioredoxin-dependent peroxiredoxin system from *Helicobacter pylori*: genetic and kinetic characterization. *J. Bacteriol.* **183**: 1961–1973.



- Banning, A., Deubel, S., Kluth, D., Zhou, Z., Brigelius-Flohé, R., 2005, The GI-GPx gene is a target for Nrf2. *Mol. Cell. Biol.* **25**: 4914–4923.
- Becker, K., Rahlfs, S., Nickel, C., Schirmer, R.H., 2003, Glutathione–functions and metabolism in the malarial parasite *Plasmodium falciparum*. *Biol. Chem.* **384**: 551–566.
- Bozonet, S.M., Findlay, V.J., Day, A.M., Cameron, J., Veal, E.A., Morgan, B.A., 2005, Oxidation of a eukaryotic 2-Cys peroxiredoxin is a molecular switch controlling the transcriptional response to increasing levels of hydrogen peroxide. *J Biol Chem.* **280**: 23319–23327.
- Brigelius-Flohé, R., Banning, A., Kny, M., Bol, G.F., 2004, Redox events in interleukin-1 signaling. *Arch. Biochem. Biophys.* **423**: 66–73.
- Brigelius, R., 1985, Mixed disulfides: biological functions and increase in oxidative Stress. Academic Press, London, Orlando, San Diego, New York, Toronto, Montreal, Sydney, Tokyo.
- Bryk, R., Griffin, P., Nathan, C., 2000, Peroxynitrite reductase activity of bacterial peroxiredoxins. *Nature* **407**: 211–215.
- Bryk, R., Lime, C.D., Erdjument-Bromage, H., Tempst, P., Nathan, C., 2002, Metabolic enzymes of mycobacteria linked to antioxidant defense by a thioredoxin-like protein. *Science* **295**: 1073–1077
- Budde, H., Flohé, L., Hecht, H.-J., Hofmann, B., Stehr, M., Wissing, J., Lünsdorf, H., 2003, Kinetics and redox-sensitive oligomerization reveal negative subunit cooperativity in trypanothione peroxidase of *Trypanosoma brucei brucei*. *Biol. Chem.* **384**: 619–633.
- Cao, Z., Roszak, A.W., Gourlay, L.J., Lindsay, J.G., Isaacs N.W., 2005, Bovine mitochondrial peroxiredoxin III forms a two-ring catenane. *Structure* **13**: 1661–1664.
- Carnieri, E.G., Moreno, S.N., Docampo, R., 1993, Trypanothione-dependent peroxide metabolism in *Trypanosoma cruzi* different stages. *Mol. Biochem. Parasitol.* **61**: 79–86.
- Castro, H., Sousa, C., Santos, M., Cordeiro-da-Silva, A., Flohé, L., Tomas, A.M., 2002, Complementary antioxidant defence by cytoplasmic and mitochondrial peroxiredoxins in *Leishmania infantum*. *Free Radic. Biol. Med.* **33**: 1552–1562.
- Cha, M.-K., Kim, I.-H., 1995, Thioredoxin-linked peroxidase from human red blood cell: Evidence for the existence of thioredoxin and thioredoxin reductase in human red blood cell. *Biochem. Biophys. Res. Commun.* **217**: 900–907.
- Cha, M.-K., Yin, C.-H. Kim, I.-H., 2000, Interaction of human thiol-specific antioxidant protein I with erythrocyte plasma membrane. *Biochemistry* **39**: 6944–6950.
- Chae, H.Z., Chung, S.J., Rhee, S.G., 1994a, Thioredoxin-dependent peroxide reductase from yeast. *J. Biol. Chem.* **269**: 27670–27678.
- Chae, H.Z., Rhee, S.G., 1994, A thiol-specific antioxidant and sequence homology to various proteins of unknown function. *Biofactors* **4**: 177–180.
- Chae, H.Z., Uhm, T.B., Rhee, S.G., 1994c, Dimerization of thiol-specific antioxidant and the essential role of cysteine 47. *Proc. Natl. Acad. Sci. USA* **91**: 7022–7026.
- Chae, H.Z., Kim, I.H., Kim, K., Rhee, S.G., 1993, Cloning, sequencing, and mutation of thiol-specific antioxidant gene of *Saccharomyces cerevisiae*. *J. Biol. Chem.* **268**: 16815–16821.
- Chae, H.Z., Robison, K., Poole, L.B., Church, G., Storz, G., Rhee, S.G., 1994b, Cloning and sequencing of thiol-specific antioxidant from mammalian brain: Alkyl hydroperoxide reductase and thiol-specific antioxidant define a large family of antioxidant enzymes. *Proc. Natl. Acad. Sci. USA* **91**: 7017–7021.
- Choi, H.-J., Kang, S.W., Yang, C.-H., Rhee, S.G., Ryu, S.-E., 1998, Crystal structure of a novel human peroxidase enzyme at 2.0 Å resolution. *Nature Struct. Biol.* **5**: 400–406.
- Choi, M.-H., Sajed, D., Poole, L., Hirata, K., Herdman, S., Torian, B.E., Reed, S.L., 2005, An unusual surface peroxiredoxin protects invasive *Entamoeba histolytica* from oxidant attack. *Mol. Biochem. Parasitol.* **143**: 80–89.
- Christman, M.F., Storz, G., Ames, B.N., 1989, OxyR, a positive regulator of hydrogen peroxide-inducible genes in *Escherichia coli* and *Salmonella typhimurium*, is homologous to a family of bacterial regulatory proteins. *Proc. Natl. Acad. Sci. USA* **86**: 3484–3488.
- Comini, M., Menge, U., Wissing, J., Flohé, L., 2005, Trypanothione synthesis in *Crithidia* revisited. *J. Biol. Chem.* **280**: 6850–6860.
- Comini, M.A., Guerrero, S.A., Haile, S., Menge, U., Lünsdorf, H., Flohé, L., 2004, Validation of *Trypanosoma brucei* trypanothione synthetase as drug target. *Free Radic. Biol. Med.* **36**: 1289–1302.

- Czech. M.P., Lawrence. J.C. Jr., Lynn. W.S., 1974, Evidence for the involvement of sulfhydryl oxidation in the regulation of fat cell hexose transport by insulin. *Proc. Natl. Acad. Sci. USA* **71**: 4173–4177.
- Declercq. J.-P., Evrard, C., Clippe. A., van der Stricht. D., Bernard. A., Knoops, B., 2001, Crystal structure of human peroxiredoxin 5, a novel type of mammalian peroxiredoxin at 1.5 Å resolution. *J. Mol. Biol.* **311**: 751–759.
- Dormeyer, M., Reckenfelderbäumer, N., Lüdemann, H., Krauth-Siegel, R.L., 2001, Trypanothione-dependent synthesis of deoxyribonucleotides by *Trypanosoma brucei* ribonucleotide reductase. *J. Biol. Chem.* **276**: 10602–10606.
- Dumas, C., Ouellette, M., Tovar, J., Cunningham, M.L., Fairlamb, A.H., Tamar, S., Olivier, M., Papadopoulou, B., 1997, Disruption of the trypanothione reductase gene of *Leishmania* decreases its ability to survive oxidative stress in macrophages. *EMBO J.* **16**: 2590–2598.
- Eling, T.E., Glasgow, W.C., 1994, Cellular proliferation and lipid metabolism: importance of lipoxygenases in modulating epidermal growth factor-dependent mitogenesis. *Cancer Metastasis Rev.* **13**: 397–410.
- Ellis, H.R., Poole, L.B., 1997, Novel application of 7-chloro-4-nitrobenzo-2-oxa-1,3-diazole to identify cysteine sulfenic acid in the AhpC component of alkyl hydroperoxide reductase. *Biochemistry* **36**:15013–15018.
- Evrard, C., Capron, A., Marchand, C., Clippe, A., Wattiez, R., Soumillon, P., Knoops, B., Declercq, J.-P., 2004, Crystal structure of a dimeric oxidized form of human peroxiredoxin 5. *J. Mol. Biol.* **337**: 1079–1090.
- Fairlamb, A., 2003, Chemotherapy of human African trypanosomiasis: current and future prospects. *Trends Parasitol.* **19**: 488–494.
- Fairlamb, A.H., Cerami, A., 1992, Metabolism and functions of trypanothione in the Kinetoplastida. *Ann. Rev. Microbiol.* **46**: 695–729.
- Finkel, T., 2000, Redox-dependent signal transduction. *FEBS Lett.* **476**: 52–54.
- Fischer. E.H., 1997, Cellular regulation by protein phosphorylation: a historical overview. *Biofactors* **6**: 367–374.
- Fisher. A.B., Dodia. C., Manevich. Y., Chen. J.W., Feinstein. S.I., 1999, Phospholipid hydroperoxides are substrates for non-selenium glutathione peroxidase. *J. Biol. Chem.* **274**: 21326–21334.
- Flohé. L., 1998, The Achilles' heel of trypanosomatids: trypanothione-mediated hydroperoxide metabolism. *Biofactors* **8**: 87–91.
- Flohé. L., 1989, The selenoprotein glutathione peroxidase. John Wiley & Sons, Inc., New York.
- Flohé. L., Andreesen. J.R., Brigelius-Flohé. R., Maiorino. M., Ursini. F., 2000, Selenium, the element of the moon, in life on earth. *IUBMB Life* **49**: 411–420.
- Flohé L., Brigelius-Flohé R., 2006, Selenoproteins of the glutathione system. Kluwer Academic Publishers, Boston, Dordrecht, London.
- Flohé, L., Brigelius-Flohé, R., Saliou, C., Traber, M.G., Packer, L., 1997, Redox regulation of NF-kappa B activation. *Free Radic. Biol. Med.* **22**: 1115–1126.
- Flohé, L., Budde, H., Bruns, K., Castro, H., Clos, J., Hofmann, B., Kansal-Kalavar, S., Krumme, D., Menge, U., Plank-Schumacher, K., Sztajer, H., Wissing., Wylegalla, C., Hecht, H.J., 2002, Tryparedoxin peroxidase of *Leishmania donovani*: molecular cloning, heterologous expression, specificity, and catalytic mechanism. *Arch. Biochem. Biophys.* **397**: 324–335.
- Flohé, L., Hecht, H.J., Steinert, P., 1999, Glutathione and trypanothione in parasitic hydroperoxide metabolism. *Free Radic. Biol. Med.* **27**: 966–984.
- Gao, L., Tse, S.-W., Conrad, C., Andreadis, A., 2005, Saitohin, which is nested in the tau locus and confers allele-specific susceptibility to several neurodegenerative diseases, interacts with peroxiredoxin 6. *J. Biol. Chem.* **280**: 39268–39272.
- Gommel, D.U., Nogoceke, E., Morr, M., Kiess, M., Kalisz, H.M., Flohé, L., 1997, Catalytic characteristics of tryparedoxin. *Eur. J. Biochem.* **248**: 913–918.
- Gourlay, L.J., Bhella, D., Kelly, S.M., Price, N.C. Lindsay, J.G., 2003, Structure-function analysis of recombinant substrate protein 22 kDa (SP-22). *J. Biol. Chem.* **278**: 32631–32637.
- Griendling, K.K., Ushio-Fukai, M., 2000, Reactive oxygen species as mediators of angiotensin II signaling. *Regul. Pept.* **91**: 1–27.

- Harris, J.R., 1968, Release of a macromolecular protein component from human erythrocyte ghosts. *Biochim. Biophys. Acta* **150**: 534–537.
- Harris, J.R., 1969, Some negative staining features of a protein from erythrocyte ghosts. *J. Mol. Biol.* **46**: 329–335.
- Harris, J.R., 1971, Further studies on the proteins released from haemoglobin-free erythrocyte ghosts at low ionic strength. *Biochim. Biophys. Acta* **229**: 761–770.
- Harris, J.R., 1980, Torin and Cyldrin, two extrinsic proteins of the erythrocyte membrane: a review. *Nouv. Rev. Fr. Hematol.* **22**: 411–448.
- Harris, J.R., Bhella, D., Adrian, M., 2006. Recent developments in negative staining for transmission electron microscopy. *Microscopy and Analysis*, Issue 101, May, pp. 17–21.
- Harris, J.R., Naeem, I., 1978, The subunit composition of two high molecular weight extrinsic proteins from human erythrocyte membranes. *Biochim. Biophys. Acta* **537**: 495–500.
- Harris, J.R., Schröder, E., Isupov, M.N., Scheffler, D., Kristensen, P., Littlechild, J.A., Vagin A.A., Meissner U., 2001, Comparison of the decameric structure of peroxiredoxin-II by transmission electron microscopy and X-ray crystallography. *Biochim. Biophys. Acta* **1547**: 221–234.
- Harris, J.R., Scheffler, D., 2002, Routine preparation of air-dried negatively stained specimens and unstained specimens on holey carbon support films: a review of applications. *Micron* **33**: 461–480.
- Heffetz, D., Bushkin, I., Dror, R., Zick, Y., 1990, The insulinomimetic agents H<sub>2</sub>O<sub>2</sub> and vanadate stimulate protein tyrosine phosphorylation in intact cells. *J. Biol. Chem.* **265**: 2896–2902.
- Henderson, G.B., Fairlamb, A.H., Cerami, A., 1987, Trypanothione dependent peroxide metabolism in *Crithidia fasciculata* and *Trypanosoma brucei*. *Mol. Biochem. Parasitol.* **24**: 39–45.
- Hirota, K., Murata, M., Sachi, Y., Nakamura, H., Takeuchi, J., Mori, K., Yodoi, J., 1999, Distinct roles of thioredoxin in the cytoplasm and in the nucleus. A two-step mechanism of redox regulation of transcription factor NF-kappaB. *J. Biol. Chem.* **274**: 27891–27897.
- Hirotsu, S., Abe, Y., Okada, K., Nagahara, N., Hori, H., Nishino, T., Hakoshima, T., 1999, Crystal structure of a multifunctional 2-Cys peroxiredoxin heme-binding protein 23 kDa/proliferation-associated gene product. *Proc.Natl. Acad. Sci. USA* **96**: 12333–12338.
- Hofmann, B., Hecht, H.J., Flohé, L., 2002, Peroxiredoxins. *Biol. Chem.* **383**: 347–364.
- Hungyi, S., Kim, A.T., Hedrick, C.C., Lusic, A.J., Tompkins, C., Finney, R., Leung, D.W., Paglia, D.E., 1997, Endogenous natural killer enhancing factor-B increases cellular resistance to oxidative stresses. *Free Rad. Biol. Med.* **22**: 497–507.
- Immenschuh, S., Iwahara, S., Satoh, H., Nell, C., Katz, N., Müller-Eberhard, U., 1995, Expression of the mRNA of heme-binding protein 23 is coordinated with that of heme oxygenase-1 by heme and heavy metals in primary rat hepatocytes and hepatoma cells. *Biochemistry* **34**: 13407–13411.
- Itoh, K., Wakabayashi, N., Katoh, Y., Ishii, T., Igarashi, K., Engel, J.D., Yamamoto, M., 1999, Keap1 represses nuclear activation of antioxidant responsive elements by Nrf2 through binding to the amino-terminal Neh2 domain. *Genes Devel.* **13**: 76–86.
- Iwahara, S., Satoh, H., Song, D.X., Webb, J., Burlingame, A.L., Nagae, Y., Müller-Eberhard, U., 1995, Purification, characterization, and cloning of a heme-binding protein (23 kDa) in rat liver cytosol. *Biochemistry* **34**: 13398–13406.
- Jacob, H.S., Jandl, J.H., 1966, Effects of sulfhydryl inhibition on red blood cells. 3. Glutathione in the regulation of the hexose monophosphate pathway. *J. Biol. Chem.* **241**: 4243–4250.
- Jacobson, F.S., Morgan, R.W., Christman, M.F., Ames, B.N., 1989, An alkyl hydroperoxide reductase from *Salmonella typhimurium* involved in the defense of DNA against oxidative damage. Purification and properties. *J. Biol. Chem.* **264**: 1488–1496.
- Jaeger, T., Budde, H., Flohé, L., Menge, U., Singh, M., Trujillo, M., Radi, R., 2004, Multiple thioredoxin-mediated routes to detoxify hydroperoxides in *Mycobacterium tuberculosis*. *Arch. Biochem. Biophys.* **423**: 182–191.
- Jaeger, T., Flohé, L., 2006, The thiol-based redox network of pathogens as target in the search for new drugs. *BioFactors* **27**: 109–120.
- Jäschke, A., Mi, H., Tropschug, M., 1998, Human T cell cyclophilin18 binds to thiol-specific antioxidant protein Aop1 and stimulates its activity. *J. Mol. Biol.* **277**: 763–769.

- Jang, H.H., Lee, K.O., Chi, Y.H., Jung, B.G., Park, S.K., Park, J.H., Lee, J.R., Lee, S.S., Moon, J.C., Yun, J.W., Choi, Y.O., Kim, W.Y., Kang, J.S., Cheong, C.-W., Yun, D.-J., Rhee, S.G., Cho, M.J., Lee, S.Y., 2004, Two enzymes in one: two yeast peroxiredoxins display oxidative stress-dependent switching from a peroxidase to a molecular chaperone function. *Cell* **117**: 625–635.
- Jenney, F.E. Jr., Verhagen, M.F., Cui, X., Adams, M.W., 1999, Anaerobic microbes: oxygen detoxification without superoxide dismutase. *Science* **286**: 306–309.
- Jeon, S.-J., Ishikawa, K., 2003, Characterization of novel hexadecameric thioredoxin peroxidase from *Aeropyrum pernix* K1\*. *J. Biol. Chem.* **278**: 24174–24180.
- Kato, H., Asanoi, M., Nakazawa, T., Maruyama, K., 1985, Cylinder protein isolated from rat liver mitochondria. *Zool. Sci.* **2**: 485–490.
- Kawai, S., Takeshita, S., Okazaki, M., Kikuno, R., Kudo, A., Amann, E., 1994, Cloning and characterization of OSF-3, a new member of the MER5 family, expressed in mouse osteoblastic cells. *J. Biochem.* **115**: 641–643.
- Kim, K., Kim, I.H., Lee, K.Y., Rhee, S.G., Stadtman, E.R., 1988, The isolation and purification of a specific “protector” protein which inhibits enzyme inactivation by a thiol/Fe(III)/O<sub>2</sub> mixed-function oxidation system. *J. Biol. Chem.* **263**: 4704–4711.
- Kim, S.H., Fountoulakis, M., Cairns, N., Lubec, G., 2001, Protein levels in human peroxiredoxin subtypes in brains of patients with Alzheimer’s disease and Down syndrome. *J. Neural Transm. Suppl* **61**: 223–235.
- Kitano, K., Niimura, Y., Nishiyama, Y., Miki, K., 1999, Stimulation of peroxidase activity by decamerization relation to ionic strength: AhpC protein from *Amphibacillus xylanus*. *J. Biochem.* **126**: 313–319.
- Krapfenbauer, K., Engidawork, E., Cairns, N., Fountoulakis, M., Lubec, G., 2003, Aberrant expression of peroxiredoxin subtypes in neurodegenerative disorders. *Brain Res.* **967**: 152–160.
- Krauth-Siegel, R.L., Meiering, S.K., Schmidt, H., 2003, The parasite-specific trypanothione metabolism of trypanosoma and leishmania. *Biol. Chem.* **384**: 539–549.
- Krieger, S., Schwarz, W., Ariyanayagam, M.R., Fairlamb, A.H., Krauth-Siegel, R.L., Clayton, C., 2000, Trypanosomes lacking trypanothione reductase are avirulent and show increased sensitivity to oxidative stress. *Mol. Microbiol.* **35**: 542–552.
- Kristensen, P., Rasmussen, D.E., Kristensen, B.I., 1999, Properties of thiol-specific anti-oxidant protein or calpromotin in solution. *Biochem. Biophys. Res. Commun.* **262**: 127–131.
- Leavey, P.J., Gonzalez-Aller, C., Thurman, G., Kleinberg, M., Rinckel, L., Ambrusso, D.W., Freeman, S., Kuypers, F.A., Ambrusso, D.R., 2002, A 29-kDa protein associated with p67phox expresses both peroxiredoxin and phospholipase A2 activity and enhances superoxide anion production by a cell-free system of NADPH oxidase activity. *J. Biol. Chem.* **277**: 45181–45187.
- Lee, S.P., Hwang, Y.S., Kim, Y.J., Kwon, K.S., Kim, H.J., Kim, K., Chae, H.Z., 2001, Cyclophilin A binds to peroxiredoxins and activates its peroxidase activity. *J Biol Chem* **276**: 29826–29832.
- Lee, T.H., Kim, S.U., Yu, S.L., Kim, S.H., Park, do S., Moon, H.B., Dho, S.H., Kwon, K.S., Kwon, H.J., Han, Y.H., Jeong, S., Kang, S.W., Shin, H.S., Lee, K.K., Rhee, S.G., Yu, D.Y., 2003, Peroxiredoxin II is essential for sustaining life span of erythrocytes in mice. *Blood* **101**: 5033–5038.
- Levick, M.P., Tetaud, E., Fairlamb, A.H., Blackwell, J.M., 1998, Identification and characterisation of a functional peroxidoxin from *Leishmania major*. *Mol. Biochem. Parasitol.* **96**: 125–137.
- Li, S., Peterson, N.A., Kim, M.-Y., Kim, C.-Y., Hung, L.-W., Yi, M., Lakin, T., Segelke, B.W., Lott, J.S., Baker, E.N., 2005, Crystal structure of AhpE from *Mycobacterium tuberculosis*, a 1-Cys peroxiredoxin. *J. Mol. Biol.* **346**: 1035–1046.
- Lim, Y.S., Cha, M.K., Kim, H.K., Uhm, T.B., Park, J.W., Kim, K., Kim, I.H., 1993, Removal of hydrogen peroxide and hydroxyl radical by thiol-specific antioxidant protein as a possible role in vivo. *Biochem. Biophys. Res. Commun.* **192**: 273–280.
- Lim, M.J., Chae, H.Z., Rhee, S.G., Yu, D.Y., Lee, K.K., Yeom, Y.I., 1998, The type II peroxiredoxin gene family of the mouse: molecular structure, expression and evolution. *Gene* **216**: 197–205.
- Lim, Y.S., Cha, M.K., Kim, H.K., Kim, I.H., 1994a, The thiol-specific antioxidant protein from human brain: gene cloning and analysis of conserved cysteine regions. *Gene* **140**: 279–284.

- Lim, Y.-S., Cha, M.K., Yun, C.-H., Kim, H.-K., Kim, K., Kim, I.-H., 1994b, Purification and characterization of thiol-specific antioxidant protein from human red blood cell: a new type of antioxidant protein. *Biochem. Biophys. Res. Commun.* **199**: 199–206.
- Lopez, J.A., Carvalho, T.U., de Souza, W., Flohé, L., Guerrero, S.A., Montemartini, M., Kalisz, H.M., Nogoceke, E., Singh, M., Alves, M.J., Colli W., 2000, Evidence for a trypanothione-dependent peroxidase system in *Trypanosoma cruzi*. *Free Radic. Biol. Med.* **28**: 767–772.
- Lüdemann, H., Dormeyer, M., Sticherling, C., Stallmann, D., Follmann, H., Krauth-Siegel, R.L., 1998, *Trypanosoma brucei* tryparedoxin, a thioredoxin-like protein in African trypanosomes. *FEBS Lett.* **431**: 381–385.
- Manevich, Y., Feinstein, S.I., Fisher, A.B., 2004, Activation of the antioxidant enzyme l-CYS peroxiredoxin requires glutathionylation mediated by heterodimerization with pi GST. *Proc. Natl. Acad. Sci. USA* **10**: 3780–3785.
- Maulik, N., Das, D.K., 2002, Redox signaling in vascular angiogenesis. *Free Radic. Biol. Med.* **33**: 1047–1060.
- Marianayagam, N.J., Sunde, M., Matthews, J.M., 2004, The power of two: protein dimerization in biology. *TIBS* **29**: 618–625.
- May, J.M., de Haen, C., 1979a, The insulin-like effect of hydrogen peroxide on pathways of lipid synthesis in rat adipocytes. *J. Biol. Chem.* **254**: 9017–9021.
- May, J.M., de Haen, C., 1979b, Insulin-stimulated intracellular hydrogen peroxide production in rat epididymal fat cells. *J. Biol. Chem.* **254**: 2214–2220.
- Meissner, U., Schröder, E., Scheffler, D., Martin, A.G., Harris, J.R., 2007, Formation, TEM study and 3D Reconstruction of the Human Erythrocyte Peroxidoredoxin-2 Dodecahedral Higher-order Assembly. *Micron* **38**: 29–39.
- Mizohata, E., Sakai, H., Fusatomi, E., Terada, T., Murayama, K., Shorouzu, M., Yokoyama, S., 2005, Crystal structure of an archeal peroxiredoxin from the aerobic hyperthermic crenarchaeon *Aeropyrum pernix*K1. *J. Mol. Biol.* **354**: 317–329.
- Moore, R.B., Plishker, G.A., Shriver, S.K., 1990, Purification and measurement of calpromotin, the cytoplasmic protein which activates calcium-dependent potassium transport. *Biochem. Biophys. Res. Commun.* **166**: 146–153.
- Moore, R.B., Mankad, M.V., Shriver, S.K., Mankad, V.N., Plishker, G.A., 1991, Reconstitution of Ca(2+)-dependent K<sup>+</sup> transport in erythrocyte membrane vesicles requires a cytoplasmic protein. *J. Biol. Chem.* **266**: 18964–18968.
- Moore, R.B., Shriver S.K., Jenkins L.D., Mankad V.N., Shah A.K., Plishker G.A., 1997, Calpromotin, a cytoplasmic protein, is associated with the formation of dense cells in sickle cell anemia. *Amer. J. Hematol.* **56**: 100–106.
- Moore, R.B., Shriver, S.K., 1997, Protein 7.2b of human erythrocyte membranes binds to calpromotin. *Biochem. Biophys. Res. Commun.* **232**: 294–297.
- Mukherjee, S.P., Lynn, W.S., 1977, Reduced nicotinamide adenine dinucleotide phosphate oxidase in adipocyte plasma membrane and its activation by insulin. Possible role in the hormone's effects on adenylate cyclase and the hexose monophosphate shunt. *Arch. Biochem. Biophys.* **184**: 69–76.
- Nakashima, K., Pontremoli, S., Horecker, B.L., 1969, Activation of rabbit liver fructose diphosphatase by coenzyme A and acyl carrier protein. *Proc. Natl. Acad. Sci. USA* **64**: 947–951.
- Netto, L.E.S., Chae, H.Z., Kang, S.-W., Rhee, S.G., Stadtman, E.R., 1996, Removal of hydrogen peroxide by thiol-specific antioxidant enzyme (TSA) is involved with its antioxidant properties. *J. Biol. Chem.* **271**: 15315–15321.
- Nogoceke, E., Gommel, D.U., Kiess, M., Kalisz, H.M., Flohé, L., 1997, A unique cascade of oxidoreductases catalyses trypanothione-mediated peroxide metabolism in *Crithidia fasciculata*. *Biol. Chem.* **378**: 827–836.
- Pedrajas, J.R., Miranda-Vizuete, A., Javanmardy, N., Gustafsson, J.A., Spyrou, G., 2000, Mitochondria of *Saccharomyces cerevisiae* contain one-conserved cysteine type peroxiredoxin with thioredoxin peroxidase activity. *J. Biol. Chem.* **275**: 16296–16301.

- Phalen, T.J., Weirather, K., Deming, P.B., Anathy, V., Howe, A.K., van der Vlier, A., Jönsson, T.J., Poole, L.B., Heintz, N.H., 2006, Oxidation state governs structural transitions in peroxiredoxin II that correlate with cell cycle arrest and recovery. *J. Cell Biol.* **175**: 779–789.
- Plishker, G.A., White, P.A., Cadman, E.D., 1986, Involvement of a cytoplasmic protein calcium-dependent potassium efflux in red blood cells. *Am. J. Physiol.* **251**: C535.
- Plishker, G.A., Chevalier, D., Seinoth, L., Moore, R.B., 1992, Calcium-activated potassium transport and high molecular weight forms of calpromotin. *J. Biol. Chem.* **267**: 21839–21843.
- Pontremoli, S., Luppis, B., Traniello, S., Rippa, M., Horecker, B.L., 1965, Fructose diphosphatase from rabbit liver.IV. Sulfhydryl groups and their relation to the catalytic activity. *Arch. Biochem. Biophys.* **112**: 1–15.
- Pontremoli, S., Traniello, S., Enser, M., Shapiro, S., Horecker, B.L., 1967, Regulation of fructose diphosphatase activity by disulfide exchange. *Proc. Natl. Acad. Sci. USA* **58**: 286–293.
- Poole, L.B., Ellis, H.R., 2002, Identification of cysteine sulfenic acid in AhpC of alkyl hydroperoxide reductase. *Meth. Enzymol.* **348**: 122–136.
- Posner, B.I., Faure, R., Burgess, J.W., Bevan, A.P., Lachance, D., Zhang-Sun, G., Fantus, I.G., Ng, J.B., Hall, D.A., Lum, B.S., *et al.*, 1994, Peroxovanadium compounds. A new class of potent phosphotyrosine phosphatase inhibitors which are insulin mimetics. *J. Biol. Chem.* **269**: 4596–4604.
- Rabilloud, T., Berthier, R., Vincon, M., Ferbus, D., Doubin, G., Lawrence, J.J., 1995, Early events in erythroid differentiation: accumulation of the acidic peroxiredoxin. *Biochem. J.* **312**: 669–705.
- Radeke, H.H., Meier, B., Topley, N., Flöge, J., Habermehl, G.G., Resch, K., 1990, Interleukin 1- $\alpha$  and tumor necrosis factor- $\alpha$  induce oxygen radical production in mesangial cells. *Kidney Int.* **37**: 767–775.
- Ralat, L.A., Manevich, Y., Fisher, A.B., Colman R.F., 2006, Direct evidence for the formation of a complex between 1-cysteine peroxiredoxin and glutathione S-transferase pi with activity changes in both enzymes. *Biochemistry* **45**: 360–372.
- Reynolds, C.M., Poole, L.B., 2001, Activity of one of two engineered heterodimers of AhpF, the NADH:peroxiredoxin oxidoreductase from *Salmonella typhimurium*, reveals intrasubunit electron transfer between domains. *Biochemistry* **40**: 3912–3919.
- Rhee, S.G., 1999, Redox signalling: hydrogen peroxides as intracellular messenger. *Exptl. Molec. Med.* **31**: 53–59.
- Rhee, S.G., Chang, T.S., Bae, Y.S., Lee, S.R., Kang, S.W., 2003, Cellular regulation by hydrogen peroxide. *J. Am. Soc. Nephrol.* **14**(8 Suppl 3):S211–215.
- Rhee, S.G., Kang, S.W., Jeong, W., Chang, T.-S., Yang, K.-S., Woo, H.A., 2005, Intracellular messenger function of hydrogen peroxide and its regulation by peroxiredoxins. *Curr. Opin. Cell Biol.* **17**: 183–189.
- Saitoh, M., Nishitoh, H., Fujii, M., Takeda, K., Tobiume, K., Sawada, Y., Kawabata, M., Miyazono, K., Ichijo, H., 1998, Mammalian thioredoxin is a direct inhibitor of apoptosis signal-regulating kinase (ASK) 1. *EMBO J.* **17**: 2596–2606.
- Sarma, G.N., Nickel, C., Rahlfs, S., Fischer, M., Becker, K., Karplus, P.A., 2005, Crystal structure of a novel *Plasmodium falciparum* 1-Cys peroxiredoxin. *J. Mol. Biol.* **346**: 1021–1034.
- Sasagawa, I., Matsuki, S., Suzuki, Y., Iuchi, Y., Tohya, K., Kimura, M., Nakada, T., Fujii, J., 2001, Possible involvement of the membrane-bound form of peroxiredoxin 4 in acrosome formation during spermiogenesis of rats. *Eur J. Biochem.* **268**: 3053–3061.
- Schmidt, A.K., Krauth-Siegel, R., 2002, Enzymes of the trypanothione metabolism as targets for antitrypanosomal drug development. *Curr. Top. Med. Chem.* **2**:1239–1259.
- Schmidt, A and Krauth-Siegel, RL (2002) Enzymes of the trypanothione metabolism as targets for antitrypanosomal drug development. *Curr Top Med Chem*:1239–1259.
- Schröder, E., Isupov, M.N., Naran, A., Littlechild, J.A., 1999, Crystallization and preliminary X-ray analysis of human thioredoxin peroxidase-B from red blood cells. *Acta Cryst.* **D55**: 536–538.
- Schröder, E., Littlechild, J.A., Lebedev, A.A., Errington, N., Vagin, A.A., Isupov, M.N., 2000, Crystal structure of decameric 2-Cys peroxiredoxin from human erythrocytes at 1.7 Å resolution. *Structure* **8**: 605–615.

- Schröder, E., Ponting, C.P., 1998. Evidence that the peroxiredoxins are novel members of the thioredoxin fold superfamily. *Protein Science* **7**: 2465–2468.
- Schröder, E., Willis, A.C., Ponting, C.P., 1998. Porcine natural-killer enhancing factor-B: oligomerization and identification as a calpain substrate in vitro. *Biochim Biophys. Acta* **1383**: 279–291.
- Shau, H., Kim, A., 1994. Identification of natural killer enhancing factor as a major antioxidant in human red blood cells. *Biochem. Biophys. Res. Commun.* **199**: 83–88.
- Shau, H., Kim, A.T., Hedrick, C.C., Lusic, A.J., Tompkins, C., Finney, R., Leung, D.W., Paglia, D.E., 1997. Endogenous natural killer enhancing factor-B increases cellular resistance to oxidative stress. *Free Rad. Biol. Med.* **22**: 497–507.
- Sies, H., Gerstenecke, R.C., Menzel, H., Flohé, L., 1972. Oxidation in the NADP system and release of GSSG from hemoglobin-free perfused rat liver during peroxidatic oxidation of glutathione by hydroperoxides. *FEBS Lett.* **27**: 171–175.
- Söhling, B., Parther, T., Rucknagel, K.P., Wagner, M.A., Andreesen, J.R., 2001. A selenocysteine-containing peroxiredoxin from the strictly anaerobic organism *Eubacterium acidaminophilum*. *Biol. Chem.* **382**: 979–986.
- Stacy, R.A., Munthe, E., Steinum, T., Sharma, B., Aalen, R.B., 1996. A peroxiredoxin antioxidant is encoded by a dormancy-related gene, Per1, expressed during late development in the aleurone and embryo of barley grains. *Plant Mol. Biol.* **31**: 1205–1216.
- Sztajer, H., Gamain, B., Aumann, K.D., Slomianny, C., Becker, K., Brigelius-Flohé, R., Flohé, L., 2001. The putative glutathione peroxidase gene of *Plasmodium falciparum* codes for a thioredoxin peroxidase. *J. Biol. Chem.* **276**: 7397–7403.
- Tang, D.G., La, E., Kern, J., Kehrer, P., 2002. Fatty acid oxidation and signaling in apoptosis. *Biol. Chem.* **383**: 425–442.
- Tartaglia, L.A., Storz, G., Brodsky, M.H., Lai, A., Ames, B.N., 1990. Alkyl hydroperoxide reductase from *Salmonella typhimurium*. Sequence and homology to thioredoxin reductase and other flavoprotein disulfide oxidoreductases. *J. Biol. Chem.* **265**: 10535–10540.
- Tetaud, E., Giroud, C., Prescott, A.R., Parkin, D.W., Baltz, D., Biteau, N., Baltz, T., Fairlamb, A.H., 2001. Molecular characterisation of mitochondrial and cytosolic trypanothione-dependent trypanredoxin peroxidases in *Trypanosoma brucei*. *Mol. Biochem. Parasitol.* **116**: 171–183.
- Toledano, M.B., Delaunay, A., Monceau, L., Tacnet, F., 2004. Microbial H<sub>2</sub>O<sub>2</sub> sensors as archetypical redox signaling modules. *TIBS.* **29**: 351–357.
- Tovar, J., Cunningham, M.L., Smith, A.C., Croft, S.L., Fairlamb, A.H., 1998a. Down-regulation of *Leishmania donovani* trypanothione reductase by heterologous expression of a trans-dominant mutant homologue: effect on parasite intracellular survival. *Proc. Natl. Acad. Sci. USA* **95**: 5311–5316.
- Tovar, J., Wilkinson, S., Mottram, J.C., Fairlamb, A.H., 1998b. Evidence that trypanothione reductase is an essential enzyme in *Leishmania* by targeted replacement of the tryA gene locus. *Mol. Microbiol.* **29**: 653–660.
- Trujillo, M., Budde, H., Pineyro, M.D., Stehr, M., Robello, C., Flohé, L., Radi, R., 2004. *Trypanosoma brucei* and *Trypanosoma cruzi* trypanredoxin peroxidases catalytically detoxify peroxynitrite via oxidation of fast reacting thiols. *J. Biol. Chem.* **279**: 34175–34182.
- Ursini, F., Heim, S., Kiess, M., Maiorino, M., Roveri, A., Wissing, J., Flohé, L., 1999. Dual function of the selenoprotein PHGPx during sperm maturation. *Science* **285**: 1393–1396.
- Veal, E.A., Findlay, V.J., Day, A.M., Bozonet, S.M., Evans, J.M., Quinn, J., Morgan, B.A., 2004. A 2-Cys peroxiredoxin regulates peroxide-induced oxidation and activation of a stress-activated MAP kinase. *Mol. Cell.* **15**: 129–139.
- Vivancos, A.P., Castillo, E.A., Biteau, B., Nicot, C., Ayte, J., Toledano, M.B., Hidalgo, E., 2005. A cysteine-sulphinic acid in peroxiredoxin regulates H<sub>2</sub>O<sub>2</sub>-sensing by the antioxidant Pap1 pathway. *Proc. Natl. Acad. Sci. USA* **102**: 8875–8880.
- Watabe, S., Hiroi, T., Yamamoto, Y., Fujioka, Y., Hasegawa, H., Yago, N., Takahashi, S.Y., 1997. SP-22 is a thioredoxin-dependent peroxide reductase in mitochondria. *Eur. J. Biochem.* **249**: 52–60.
- Wilkinson, S.R., Prathalingam, S.R., Kelly, J.M., 2003. RNA interference identifies two hydroperoxide metabolizing enzymes that are essential to the bloodstream form of the African trypanosome. *J. Biol. Chem.* **278**: 31640–31646.

- Wilkinson, S.R., Temperton, N.J., Mondragon, A., Kelly, .M., 2000, Distinct mitochondrial and cytosolic enzymes mediate trypanothione-dependent peroxide metabolism in *Trypanosoma cruzi*. *J. Biol. Chem.* **275**: 8220–8225.
- Wood, Z., Schröder, E., Harris, J.R., Poole, L.B., 2003, Structure, mechanism and regulation of peroxiredoxins. *TIBS* **28**: 32–40.
- Yamamoto, T., Matsui, Y., Natori, S., Obinata, M., 1989, Cloning of a housekeeping gene (MER5) preferentially expressed in murine erythroleukemia cells. *Gene* **80**: 337–343.
- Zhu, H., Bunn, H.F., 1999, Oxygen sensing and signaling: impact on the regulation of physiologically important genes. *Respir. Physiol.* **115**: 239–247.

Note added in proof: Recently Netto's group in Sao Paulo has provided compelling evidence that the physiological reductant of 1-Cys Prx is not necessarily a thiol, but is ascorbate in yeast and other species of diverse phyla [G. Monteiro, B. B. Horta, D. C. Pimenta, O. Augusto and L. E. S. Netto (2007) Reduction of 1-Cys peroxiredoxin changes the thiol-specific paradigm, revealing another function of vitamin C. *Proc Natl. Acad. Sci. USA* **104**: 4886–4891].



## CHAPTER 2

### EVOLUTION OF THE PEROXIREDOXINS

#### *Taxonomy, homology and characterization*

BERNARD KNOOPS, ELÉONORE LOUMAYE  
AND VALÉRIE VAN DER ECKEN

*Laboratory of Cell Biology, Institut des Sciences de la Vie, Université catholique de Louvain, Place  
Croix du Sud, 5, B-1348 Louvain-la-Neuve, Belgium*

**Abstract:** Peroxiredoxins compose a superfamily of peroxidases ubiquitously found throughout evolution in prokaryotes, archaea and eukaryotes. These enzymes contain a conserved catalytic peroxidatic cysteine (Cp) in the N-terminal region of the protein. The residues surrounding Cp and the catalytic site appear also to be well conserved. Peroxiredoxins can be classified either into three subfamilies according to their catalytic mechanism or into five subfamilies according to sequence homology. Notably, the number of peroxiredoxin genes increased during evolution. In eukaryotes, the higher number of genes coding for peroxiredoxin family members is due to the existence of different isoforms targeted to different subcellular compartments but is probably due also to the acquisition of new functions. Indeed, it has been postulated that the antioxidant protective role of peroxiredoxins, which is particularly critical in prokaryotes, in yeasts and in parasitic eukaryotes, may have evolved to a modulatory role in hydrogen peroxide signaling in plants and animals

**Keywords:** Peroxidase, Antioxidant enzyme, Peroxide, Bacteria, Archaea, Eukaryotes

#### 1. INTRODUCTION

The first characterized peroxiredoxin (Prx or, as imposed by International Nomenclature Committees, PRDX for human/bovine peroxiredoxins or Prdx for murine counterparts) has been identified in the yeast *Saccharomyces cerevisiae* (Kim *et al.*, 1988). Subsequently, it appeared that this novel antioxidant enzyme, named at that time TSA for thiol-specific antioxidant, was a member of an emerging superfamily of proteins conserved throughout the evolution in all kingdoms of life (Prosperi *et al.*, 1993; Chae *et al.*, 1994a). Indeed, numerous members of the Prx superfamily have been later identified and characterized in prokaryotes, archaea and eukaryotes (see Table 1; Hofmann *et al.*, 2002). It appeared afterwards that Prxs are ancestral thiol-dependent selenium- and heme-free peroxidases highly expressed

*Table 1.* Classification of Prxs from different kingdoms of life. Prxs are classified according to their enzymatic mechanism (typical 2-Cys, atypical 2-Cys or 1-Cys) and sequence homology (geometric forms in the table but see also phylogenetic tree of Fig. 2). Circles (PrxI/PRDX1 subfamily), triangles (PrxV/PRDX5 subfamily), inverted triangles (BCP-PrxQ subfamily), squares (PrxVI/PRDX6 subfamily) and hexagons (Tpx subfamily) represent the different clusters based on sequence homology. The phylogenetic tree is shape-coded accordingly. *E. coli*: *Escherichia coli*; *A. pernix*: *Aeropyrum pernix*; *S. cerevisiae*: *Saccharomyces cerevisiae*; *P. falciparum*: *Plasmodium falciparum*; *A. thaliana*: *Arabidopsis thaliana*; *D. melanogaster*: *Drosophila melanogaster*; *H. sapiens*: *Homo sapiens*

			Enzymatic mechanism			
			Typical 2-Cys	Atypical 2-Cys	1-Cys	
<b>Bacteria</b>	<i>E. coli</i>	AhpC	O			
		Tpx		⬡		
		BCP			▽	
<b>Archaea</b>	<i>A. pernix</i>	Prx	□			
<b>Eukaryotes</b>	<b>Yeasts</b>	<i>S. cerevisiae</i>	Tsa1p	O		
			Tsa2p	O		
			Ahp1p	Δ		
			Prx1p			□
			Dot5p		▽	
<b>Protozoa</b>	<i>P. falciparum</i>	TPx1	O			
		TPx2	O			
		AOP			Δ	
		1-Cys-Prx			□	
<b>Plants</b>	<i>A. thaliana</i>	2-Cys PrxA	O			
		2-Cys PrxB	O			
		PrxIIB	Δ			
		PrxIIC	Δ			
		PrxIID	Δ			
		PrxIIE	Δ			
		PrxIIF	Δ			
		1-Cys Prx			□	
PrxQ		▽				
<b>Animals</b>	<i>D. melanogaster</i>	Prx4156	O			
		Prx4783	O			
		Prx5037	O			
		PrxV		Δ		
		Prx6005			□	
		Prx2540			□	
	<i>H. sapiens</i>	PRDX1	O			
		PRDX2	O			
		PRDX3	O			
		PRDX4	O			
PRDX5		Δ				
PRDX6			□			

in virtually all living species including anaerobic organisms (Wood *et al.*, 2003a; Rhee *et al.*, 2005). In *Escherichia coli*, Prxs are among the ten most expressed proteins (Link *et al.*, 1997) and in mammalian cells they represent 0.1 to 0.8% of soluble proteins (Seo *et al.*, 2000). Moreover, it must be noted that Prxs are now very often detected as major spots in proteomic analyses using two-dimensional gel electrophoresis.

Interestingly, Prxs show no significant sequence homology with catalases, superoxide dismutases or other peroxidases such as selenocysteine-containing glutathione peroxidases, although they may be structurally close to them (see below and Chapter 3). Prxs do not contain any redox cofactors such as heme, flavin or metal ions. The presence of a conserved and catalytically essential cysteine residue in the N-terminal domain of all Prxs, termed now the peroxidatic cysteine (Cp), was noted earlier (Chae *et al.*, 1994b). Not only the residues surrounding the Cp but also the entire peroxidatic catalytic site appear to be well conserved among Prxs (Wood *et al.*, 2003a and see Chapter 3 and 4). The N-terminal Cp is the primary site of enzyme oxidation (Figure 1 and see Chapter 3 and 4). Indeed, the Cp attacks the peroxide and is subsequently oxidized to a cysteine sulfenic acid (Cp-SOH) (Wood *et al.*, 2003a and Chapter 4). The high reactivity of the conserved Cp in Prxs with peroxides is due to its low  $pK_a$  in its catalytic site. Indeed, the Cp environment promotes ionization of the thiol group to the thiolate anion (Wood *et al.*, 2003a and Chapter 4). The reduction of the cysteine sulfenic acid is the second step of the peroxidase reaction and differs according to the type of Prx (Figure 1 and Chapter 4) but probably also depends on the availability of the electron-donor substrate for certain Prxs. Based on the resolution mechanism and the existence or the lack of a resolving cysteine (Cr) localized to the C-terminal region of the enzyme, Prxs were divided into three subgroups referred to as typical 2-Cys, atypical 2-Cys and 1-Cys Prxs (Seo *et al.*, 2000). Finally, at the end of the catalytic cycle, the enzyme is reduced by a thiol-containing reductant. Thus, the conservation and the success of Prxs throughout evolution may be due to their apparently simple catalytic mechanism that does not require heme, flavin or reactive heteroatoms. It could also be due to their ability to use, depending on the type of Prx, different electron donor substrates such as thioredoxins, trypanredoxin, glutathione or glutaredoxins for their reduction. However, the drawback of this simple mechanism would be their moderate catalytic efficiencies towards peroxides ( $\sim 10^5 \text{ M}^{-1} \text{ s}^{-1}$ ) compared to selenocysteine-containing glutathione peroxidases ( $\sim 10^8 \text{ M}^{-1} \text{ s}^{-1}$ ) or even heme-containing catalases ( $\sim 10^6 \text{ M}^{-1} \text{ s}^{-1}$ ).

Functionally, it has been proposed that certain Prxs (typical 2-Cys Prxs) have evolved from antioxidant protective enzymes in bacteria or in parasites to regulators of peroxide-mediated signaling cascades in organisms such as yeasts, plants and mammals (Wood *et al.*, 2003, see also Chapter 12). Indeed, many cell types are known to produce hydrogen peroxide in response to extracellular stimuli and the generated peroxide may affect the function of several proteins including transcription factors or protein kinases and phosphatases (Rhee *et al.*, 2005). In mammals, typical 2-Cys Prxs have been shown to be more sensitive to inactivation than prokaryotic Prxs by hydrogen peroxide through overoxidation of the Cp into

## (a) typical 2-Cys Prx

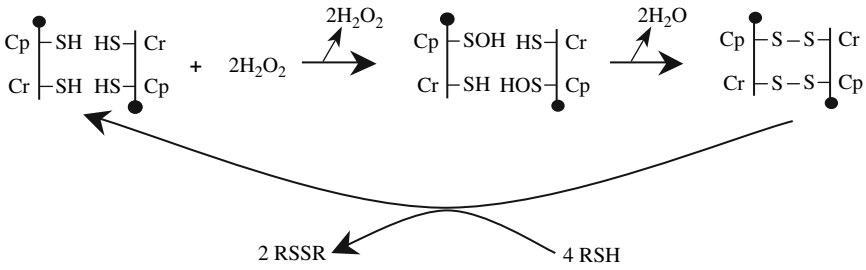

## (b) atypical 2-Cys Prx

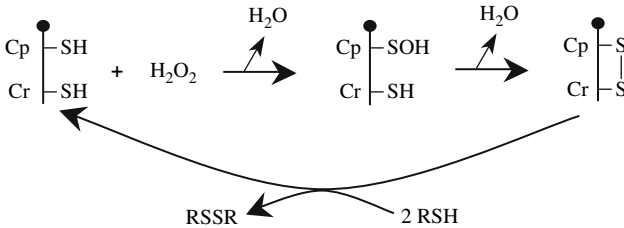

## (c) 1-Cys Prx

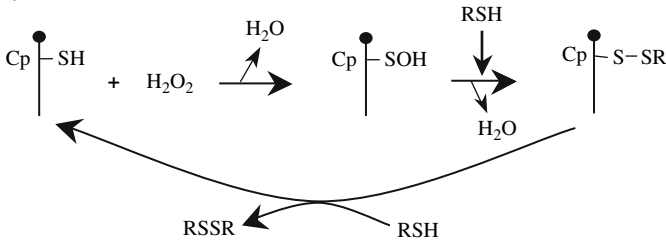

**Figure 1.** Peroxidase reaction mechanisms of (a) typical 2-Cys Prxs; (b) atypical 2-Cys Prxs; (c) 1-Cys Prxs (modified from Chae *et al.*, 1994b; Kang *et al.*, 1998; Seo *et al.*, 2000). Hydrogen peroxide ( $\text{H}_2\text{O}_2$ ) or organic hydroperoxides (ROOH) are reduced by the Cp, which is oxidized in sulfenic acid (-SOH). This later reacts immediately with a thiol group to form an intermolecular (typical 2-Cys Prxs) or an intramolecular (atypical 2-Cys Prxs) disulfide bond, which is subsequently reduced by thiol-containing electron donors (RSH) that are thioredoxins for mammalian typical and atypical 2-Cys Prxs and glutathione for mammalian 1-Cys Prx. Cp and Cr refer to peroxidatic and resolving cysteines respectively. Closed circles correspond to the amino-terminus of each protein

sulfinic (Cp-SO<sub>2</sub>H) or sulfonic (Cp-SO<sub>3</sub>H) acid forms. As such, Prxs would act as a dam against peroxides. The ratio of active to inactive enzymes would determine the signaling cascade and the oxidation of transcription factors or signaling effectors by peroxides (Wood *et al.*, 2003b; Rhee *et al.*, 2005). Interestingly, this mechanism is probably finely regulated as overoxidation of the Cp into sulfinic acid may be reduced by sulfiredoxin in yeasts, plants and mammals (Biteau *et al.*, 2003; Jeong *et al.*, 2006; Liu *et al.*, 2006), and also by sestrins (Budanov *et al.*, 2004). Moreover, phosphorylation of mammalian typical 2-Cys Prxs by cyclin-dependent kinases was also demonstrated to modulate their peroxidase activity, showing that other post-translational mechanisms in addition to overoxidation may regulate peroxide reduction by mammalian Prxs (Chang *et al.*, 2002).

As a matter of fact, the number of *Prx* genes increased throughout evolution depending also on the phyla and species. For example, there are three genes coding for Prxs in the bacterium *Escherichia coli*, five in the yeast *Saccharomyces cerevisiae*, but six in *Homo sapiens* and even nine in the plant *Arabidopsis thaliana* (Table 1). In eukaryotes, the higher number of genes coding for family members is partly explained by the compartmentalization and the existence of mitochondrial, nuclear, peroxisomal and chloroplast isoforms. However, Prx functions in metazoa could be more complex than thought previously. Indeed, knocked-out mice for *Prdx1* (Neumann *et al.*, 2003), *Prdx2* (Lee *et al.*, 2003) and *Prdx6* (Wang *et al.*, 2003) have revealed that mutants are more sensitive to certain oxidative stresses.

## 2. CLASSIFICATION OF PEROXIREDOXINS

As mentioned above, all Prxs exhibit a conserved Cp residue in their N-terminal region that attacks peroxides but also peroxynitrite at least for some members of the family (Bryk *et al.*, 2000; Dubuisson *et al.*, 2004; Jaeger *et al.*, 2004). Originally in mammals, Prxs were divided into two subfamilies (or subgroups), the 1-Cys and the 2-Cys Prxs, based on the number of cysteine residues directly involved in the enzymatic mechanism and the conservation of surrounding residues around catalytic cysteines (Rhee *et al.*, 2005). Later, a third subfamily emerged and now mammalian Prxs are divided into three subfamilies referred to as typical 2-Cys, atypical 2-Cys and 1-Cys Prxs (Rhee *et al.*, 2005; Figure 1 and Table 1). This classification is based on catalytic mechanisms and has been extended to all Prxs from all biological kingdoms. In the typical 2-Cys subfamily, the resolving cysteine, corresponding to the second redox-active cysteine, is localized to the C-terminal region of the enzyme. During the peroxidase reaction, the cysteine sulfenic acid from one subunit is attacked by the resolving cysteine of another subunit resulting in the formation of a stable intersubunit disulfide bond which can then be reduced by thioredoxin in mammalian Prxs. In atypical 2-Cys Prxs, the C-terminal resolving cysteine is located within the same polypeptide chain and the reaction with the peroxidatic cysteine results in the formation of an intramolecular disulfide bond. The mammalian atypical 2-Cys Prx uses thioredoxin to reduce the disulfide bond. Finally, in 1-Cys Prxs, only the N-terminal peroxidatic cysteine is present and the resolving cysteine is

missing. Nevertheless, in mammalian 1-Cys Prx, the peroxidatic cysteine sulfenic acid formed upon reaction with peroxides is reduced by glutathione (Manevich *et al.*, 2004). Thus, it appears that this mechanistic classification may be extended to all Prxs only when the enzymatic mechanism is clearly characterized for novel Prx members first identified on homology criteria by alignment of their amino acid sequences. Indeed, sequence alignment of Prxs from prokaryotes, archaea and eukaryotes, and construction of phylogenetic trees (Verdoucq *et al.*, 1999; Hofmann *et al.*, 2002; Figure 2) revealed clusters or subfamilies that may include

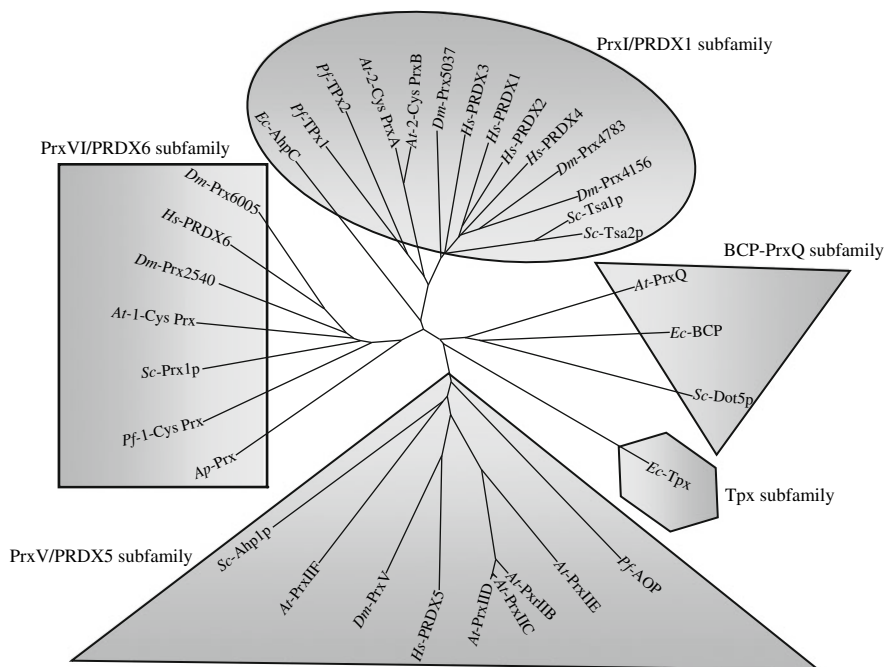

**Figure 2.** Phylogenetic tree of the peroxidredoxin family. Protein alignment was performed with ClustalX 1.81 program (Higgins and Sharp, 1988). Tree drawing was achieved with the neighbor-joining method (Saitou and Nei, 1987). The unrooted tree was drawn with Treeview, and has been divided into five clusters (subfamilies) represented by the different shapes. *Ec*: *Escherichia coli*; *Ap*: *Aeropyrum pernix*; *Sc*: *Saccharomyces cerevisiae*; *Pf*: *Plasmodium falciparum*; *At*: *Arabidopsis thaliana*; *Dm*: *Drosophila melanogaster*; *Hs*: *Homo sapiens*. GenBank™ accession numbers of the peptide sequences are as follows: *Ec*-AhpC (NP\_415138); *Ec*-Tpx (NP\_415840); *Ec*-BCP (NP\_416975); *Ap*-Prx (NP\_148509); *Sc*-Tsa1p (NP\_013684); *Sc*-Tsa2p (NP\_010741); *Sc*-Prx1p (NP\_009489); *Sc*-Dot5p (NP\_012255); *Sc*-Ahp1p (NP\_013210); *Pf*-TPx1 (AAF67110); *Pf*-TPx2 (AAK20024); *Pf*-1-Cys-Prx (AAG14353); *Pf*-AOP (1X1YA); *At*-PrxIIB (NP\_176773); *At*-PrxIIC (NP\_176772); *At*-PrxIID (NP\_564763); *At*-PrxIIE (NP\_190864); *At*-PrxIIF (NP\_566268); *At*-2-Cys PrxA (NP\_187769); *At*-2-Cys PrxB (NP\_568166); *At*-1-Cys Prx (NP\_175247); *At*-PrxQ (NP\_189235); *Dm*-Prx4156 (NM\_080263); *Dm*-Prx4783 (NM\_167359); *Dm*-Prx5037 (NM\_079663); *Dm*-PrxV (NM\_176513); *Dm*-Prx6005 (NM\_078739); *Dm*-Prx2540 (NM\_165769); *Hs*-PRDX1 (NM\_002574); *Hs*-PRDX2 (NM\_005809); *Hs*-PRDX3 (NM\_006793); *Hs*-PRDX4 (NM\_006406); *Hs*-PRDX5 (NM\_012094); *Hs*-PRDX6 (NM\_004905)

Prxs mechanistically classified as 1-Cys or 2-Cys Prxs (Figure 2 and Table 1). For example, human PRDX5, which is the prototype of an atypical 2-Cys, belongs to the phylogenetic cluster of *S. cerevisiae* Ahp1p Prx, although this one is mechanistically classified among typical 2-Cys Prxs (Park *et al.*, 2000). Interestingly, biochemical characterization of a novel Prx of *Toxoplasma gondii* has also revealed that a Prx initially classified among 1-Cys Prxs may present mechanistic features of a typical 2-Cys Prx (Deponete and Becker, 2005). As illustrated in Figure 2 and based on sequence alignment of Prxs from all biological kingdoms in agreement with Hofmann *et al.* (2002), five major clusters can be distinguished among Prxs.

More recently, several authors have proposed a third type of Prx classification based on primary sequence characteristics and structural data (Copley *et al.*, 2004; Sarma *et al.*, 2005; Mizohata *et al.*, 2005). Notably, according to these classifications, Prxs could be separated into four (Copley *et al.*, 2004) or even up to seven subfamilies (Mizohata *et al.*, 2005). However, more structural data of Prxs from various species are needed to validate these classifications. It appears also from these studies that in remote species, especially in archaea, Prxs may evolve by elongating their C-terminal domain containing additional catalytic cysteines (Mizohata *et al.*, 2005).

### 3. PEROXIREDOXINS IN PROKARYOTES

Historically, before the eukaryotic peroxiredoxin TSA from *Saccharomyces cerevisiae* was characterized (Kim *et al.*, 1988), another antioxidant enzyme from the prokaryotes *Salmonella typhimurium* and *Escherichia coli* had been identified as a peroxidase of the alkyl hydroperoxide reductase system and was named AhpC for alkyl hydroperoxide reductase subunit C (Jacobson *et al.*, 1989). This alkyl hydroperoxide reductase system was shown to be composed of the 21-kDa AhpC and the 57-kDa flavoprotein AhpF. Moreover, mechanistically, the alkyl hydroperoxide reductase system involved peroxide reduction by AhpC and subsequent reduction of AhpC for regeneration by AhpF, coupled to NAD(P)H oxidation (Jacobson *et al.*, 1989). Interestingly, homology between bacterial AhpC and *S. cerevisiae* TSA became clear (Chae *et al.*, 1994). Subsequently, two additional Prxs, the thiol peroxidase (Tpx also known as p20 and scavengase) and the thioredoxin-dependent bacterioferritin-comigratory protein (BCP), were identified and characterized in bacteria including *E. coli* (Cha *et al.*, 1995; Jeong *et al.*, 2000). Contrary to AhpC, Tpx and BCP use reducing equivalents from thioredoxin to reduce peroxides. In addition, it must be noted that novel hybrid Prx proteins with a fused glutaredoxin domain were also found recently in pathogenic and anaerobic bacteria (Vergauwen *et al.*, 2001; Kim *et al.*, 2003; Pauwels *et al.*, 2003). Functionally, prokaryotic Prxs appear to play an important role in antioxidant protection in non-pathogenic species but also in pathogenic species to defend against peroxides and peroxynitrite produced by inflammatory cells (Seaver and Imlay, 2001).

#### 4. PEROXIREDOXINS IN ARCHAEA

Genome sequencing projects as well as biochemical studies have identified Prxs in aerobic and anaerobic archaea such as *Aeropyrum pernix* (Jeon and Ishikawa, 2003; Mizohata *et al.*, 2005; see also Table 1 and Figure 2), *Sulfolobus solfataricus* (Limauro *et al.*, 2006) and *Pyrococcus horikoshii* (Kawakami *et al.*, 2004). Interestingly, as mentioned previously, data suggest also that in *A. pernix*, the new Prx could define a novel structural subfamily of Prx (Mizohata *et al.*, 2005). Indeed, this archaeal Prx presents a primary sequence homologous to mammalian PRDX6 classified in 1-Cys Prxs (see Table 1) although with a longer C-terminal extension. However, mechanistically, *A. pernix* Prx possesses at least two catalytically active cysteines that classify it among classical 2-Cys Prxs (Mizohata *et al.*, 2005). Also, the expression of archaeal Prx is induced by exogenous exposure to hydrogen peroxide in *A. pernix* and in *S. solfataricus* and by exogenous oxygen in anaerobic *P. horikoshii*, suggesting that archaeal Prx may *in vivo* act indeed as protective antioxidant enzyme (Jeon and Ishikawa, 2003; Kawakami *et al.*, 2004; Limauro *et al.*, 2006).

#### 5. PEROXIREDOXINS IN EUKARYOTES

In eukaryotes, the number of genes coding for Prxs increased compared to the number of genes identified in prokaryotes and archaea (Hofmann *et al.*, 2002; see Table 1). The higher number of Prxs in eukaryotic species may be explained both by the subcellular compartmentalization but also by the acquisition of new functions like that of a modulator of hydrogen peroxide signaling. In eukaryotic cells, Prxs are located in the cytosol, in mitochondria, in chloroplasts, in peroxisomes, and in some cases they are secreted (Hofmann *et al.*, 2002; Wood *et al.*, 2003; Leyens *et al.*, 2003).

##### 5.1. Yeast (*saccharomyces cerevisiae*)

Referring to the introduction, TSA from *S. cerevisiae* was the first Prx to be characterized (Kim *et al.*, 1988). It appeared later that four additional Prxs are encoded by distinct *S. cerevisiae* genes (Park *et al.*, 2000). Interestingly, the characterization of the five Prxs showed that depending on the isoform, they may be localized to the cytoplasm, the mitochondria, the peroxisomes or the nucleus (Park *et al.*, 2000). *S. cerevisiae* Prxs are reduced during the catalytic cycle by electrons provided by thioredoxins (Park *et al.*, 2000). Functionally, *S. cerevisiae* Prx-deficient mutants are viable but more sensitive to various oxidants and Prx-null yeast cells for the five Prxs have been reported to show an increased rate of spontaneous nuclear DNA mutations (Wong *et al.*, 2004). Interestingly, a chaperone function has recently been reported for yeast for Prxs (Jang *et al.*, 2004).

##### 5.2. Protozoa

In protozoa, Prxs have been extensively studied in *Plasmodium falciparum*, the causative agent of malaria, but also in the pathogens of the genera *Trypanosoma* and



*Leishmania* among others (Hofmann *et al.*, 2002). These parasites are challenged by reactive oxygen and nitrogen species during their life stages in humans and consequently their redox systems, including Prxs, have been thought to be essential for their pathogenicity. Interestingly, in *P. falciparum*, catalase and selenocysteine-containing glutathione peroxidases are lacking (Rahfls *et al.*, 2002). Therefore, Prxs appear as a major defense line against oxidative and nitrosative attacks in these organisms, and also as potential targets for therapeutic strategies (Hofmann *et al.*, 2002; Sarma *et al.*, 2005). In *P. falciparum*, four Prxs have been characterized and classified mechanistically among typical 2-Cys and 1-Cys Prxs (Sarma *et al.*, 2005; see Table 1). Moreover, among the four characterized *P. falciparum* Prxs, one is mitochondrial and three appear to be cytosolic (Sarma *et al.*, 2005; Yano *et al.*, 2005).

### 5.3. Plants

In *A. thaliana*, the first higher plant whose genome has been completely sequenced, phylogenetic and biochemical analyses have confirmed the existence of nine expressed Prxs (Rouhier and Jacquot, 2005; Dietz *et al.*, 2006). More recently, the analysis of the genome of *Oryza sativa* (rice) has also shown the presence of nine Prxs demonstrating that plants possess more members of the Prx family compared to prokaryotes, archaea, yeasts, protozoa or animals (Dietz *et al.*, 2006; see below and Chapter 13). In higher plants, it appeared that Prxs evolved into four distinct classes (Rouhier and Jacquot, 2005; Dietz *et al.*, 2006) corresponding to four subfamilies, as illustrated in Table 1 and Figure 2. These Prxs include typical and atypical 2-Cys Prxs and one 1-Cys Prx. Interestingly, in *A. thaliana*, four Prxs are localized to chloroplasts, three to the cytoplasm, one to mitochondria and one to the nucleus/cytoplasm. Thus, *A. thaliana* Prxs are localized to different subcellular compartments where they may act either as protective antioxidant enzymes, as modulator of peroxide- or peroxynitrite-mediated signal transduction or as redox sensors (Dietz *et al.*, 2006; Rouhier and Jacquot, 2005).

### 5.4. Animals

In animals and especially in mammals, Prxs have been known under very different names (Wood *et al.*, 2003a; Leyens *et al.*, 2003; see also Chapter 1) although their homology with yeast and bacterial Prxs was noted more than a decade ago (Prosperi *et al.*, 1993; Chae *et al.*, 1994). Functionally, the role of animal Prxs as protective antioxidant enzymes has been questioned in view of the enzymatic efficiency with peroxides of selenocysteine-containing glutathione peroxidases and catalase. These latter are expressed in the same subcellular compartments of animal cells (Hofmann *et al.*, 2002). Indeed, at least some animal Prxs may be acting more specifically as modulators of hydrogen peroxide-mediated signal transduction (Wood *et al.*, 2003; Rhee *et al.*, 2005).

#### 5.4.1. Invertebrates

Relatively few data exist on invertebrate Prxs except for insects and certain parasitic metazoa such as nematodes.

**5.4.1.1. Nematodes** In parasitic nematodes, Prxs have been studied because of their possible implication in the protection of the parasites against oxidative attacks by the host phagocytes (Henkle-Dührsen and Kampkötter, 2001). Interestingly, parasitic nematodes are able to reduce peroxides but catalase or selenocysteine-containing glutathione peroxidases are expressed at low levels in contrast to high levels of Prxs, suggesting that Prxs could be essential antioxidant enzymes in these animals (Chandrashekar *et al.*, 2000). 2-Cys and 1-Cys Prxs have been identified in nematodes such as *Onchocerca volvulus*, *Onchocerca ochengi*, *Dirofilaria immitis* or *Brugia malayi* but more biochemical and structural characterizations are needed (Henkle-Dührsen and Kampkötter, 2001).

**5.4.1.2. Insects** In *Drosophila melanogaster*, six distinct Prxs encoded by six distinct genes have been identified and characterized (Radyuk *et al.*, 2001; Radyuk *et al.*, 2003; Peterson and Luckhart, 2006). Moreover, their orthologs have been found also in the genome of *Anopheles gambiae* by *in silico* homology search in databases (Peterson and Luckhart, 2006). *D. melanogaster* Prx members are either classified among typical and atypical 2-Cys Prxs as well as 1-Cys Prxs (Table 1 and Figure 2). Three *D. melanogaster* Prxs are localized to the cytosol, two are targeted to the mitochondria and one was found to be secreted (Radyuk *et al.*, 2001; Peterson and Luckhart, 2006). Moreover, overexpression of insect Prxs conferred increased resistance to toxicity induced by hydrogen peroxide, paraquat or peroxyxynitrite (Radyuk *et al.*, 2001; Peterson and Luckhart, 2006).

#### 5.4.2. Vertebrates

In vertebrates, orthologs of mammalian Prxs have been identified in databases of fish, amphibian and bird species but so far, except of course for mammalian Prxs, there are few biochemical and functional studies available in the literature.

**5.4.2.1. Mammals** Mammalian Prxs have been extensively studied (for review see Hofmann *et al.*, 2002; Wood *et al.*, 2003a; Leyens *et al.*, 2003; Rhee *et al.*, 2005). Six distinct genes encode six different Prxs in man, rat, mouse and cattle (Leyens *et al.*, 2003; Rhee *et al.*, 2005). Mammalian Prxs have been classified mechanistically into three subfamilies. Indeed, in mammals, PRDX1 to PRDX4 are classical 2-Cys Prxs, PRDX5 is an atypical 2-Cys Prx and PRDX6 is a 1-Cys Prx (Seo *et al.*, 2000). Prxs are expressed constitutively in virtually all mammalian tissues although at different levels of expression (Seo *et al.*, 2000; Leyens *et al.*, 2003). PRDX1, PRDX2 and PRDX6 are cytosolic enzymes (Rhee *et al.*, 2005). PRDX3 is a mitochondrial Prx addressed to this organelle by an N-terminal mitochondrial presequence and PRDX4 exhibits an N-terminal signal sequence for its secretion

(Rhee *et al.*, 2005). Finally, PRDX5 presents a more complex subcellular distribution, as it has an N-terminal mitochondrial presequence, a C-terminal peroxisomal targeting sequence and it has been localized also to the cytosol and the nucleus (Knoops *et al.*, 1999; Banmeyer *et al.*, 2004; Rhee *et al.*, 2005). Human Prxs reduce peroxides by the use of reducing equivalents derived from cytosolic thioredoxin for PRDX1, PRDX2 and cytosolic PRDX5, from mitochondrial thioredoxin for PRDX3 and mitochondrial PRDX5 and finally from glutathione for PRDX6 (Manevich *et al.*, 2004; Rhee *et al.*, 2005). As mentioned before, it has been shown that the activity of certain mammalian Prxs can be modulated by posttranslational modification such as phosphorylation of a threonine residue (Chang *et al.*, 2002) or reversible overoxidation of the Cp (Chang *et al.*, 2004), suggesting that in mammals, Prxs may serve as components of hydrogen peroxide-mediated signal transduction (Wood *et al.*, 2003; Rhee *et al.*, 2005; see Chapter 15).

## ACKNOWLEDGMENTS

The work of the authors is financially supported by the Fonds National de la Recherche Scientifique (FNRS) and by the Communauté française de Belgique-Actions de Recherche Concertées (ARC).

## REFERENCES

- Banmeyer, I., Marchand, C., Verhaeghe, C., Vucic, B., Rees, J.F. and Knoops, B., 2004, Overexpression of human peroxiredoxin 5 in subcellular compartments of Chinese Hamster Ovary cells: effects on cytotoxicity and DNA damage caused by peroxides. *Free Radic. Biol. Med.*, **36**: 65–77.
- Biteau, B., Labarre, J. and Toledano, M.B., 2003, ATP-dependent reduction of cysteine-sulphinic acid by *S. cerevisiae* sulphiredoxin. *Nature*, **425**: 980–984.
- Bryk, R., Griffin, P. and Nathan, C., 2000, Peroxynitrite reductase activity of bacterial peroxiredoxins. *Nature*, **407**:211–215.
- Budanov, A.V., Sablina, A.A., Feinstein, E., Koonin, E.V. and Chumakov, P.M., 2004, Regeneration of peroxiredoxins by p53-regulated sestrins, homologs of bacterial AhpD. *Science*, **304**: 596–600.
- Cha, M.K., Kim, H.K. and Kim, I.H., 1995, Thioredoxin-linked “thiol peroxidase” from periplasmic space of *Escherichia coli*. *J. Biol. Chem.*, **270**: 28635–28641.
- Chae, H.Z., Robison, K., Poole, L.B., Church, G., Storz, G. and Rhee, S.G., 1994a, Cloning and sequencing of thiol-specific antioxidant from mammalian brain: alkyl hydroperoxide reductase and thiol-specific antioxidant define a large family of antioxidant enzymes. *Proc. Natl. Acad. Sci. USA*, **91**: 7017–7021.
- Chae, H.Z., Uhm, T.B. and Rhee, S.G., 1994b, Dimerization of thiol-specific antioxidant and the essential role of cysteine 47. *Proc. Natl. Acad. Sci. USA*, **91**: 7022–7026.
- Chandrashekar, R., Tsuji, N., Morales, T.H., Carmody, A.B., Ozols, V.O., Welton, J. and Tang, L., 2000, Removal of hydrogen peroxide by a 1-Cysteine peroxiredoxin enzyme of the filarial parasite *Dirofilaria immitis*. *Parasitol. Res.*, **86**: 200–206.
- Chang, T.S., Jeong, W., Choi, S.Y., Yu, S., Kang, S.W. and Rhee, S.G., 2002, Regulation of peroxiredoxin I activity by Cdc2-mediated phosphorylation. *J. Biol. Chem.*, **277**: 25370–25376.
- Chang, T.S., Jeong, W., Woo, H.A., Lee, S.M., Park, S. and Rhee, S.G., 2004, Characterization of mammalian sulfiredoxin and its reactivation of hyperoxidized peroxiredoxin through reduction of cysteine sulfinic acid in the active site to cysteine. *J. Biol. Chem.*, **279**: 50994–51001.

- Copley, S.D., Novak, W.R. and Babbit, P.C., 2004, Divergence of function in the thioredoxin fold superfamily: evidence for evolution of peroxiredoxins from a thioredoxin-like ancestor. *Biochemistry*, **43**: 13981–13995.
- Deponte, M. and Becker, K., 2005, Biochemical characterization of *Toxoplasma gondii* 1-Cys peroxiredoxin 2 with mechanistic similarities to typical 2-Cys Prx. *Mol. Biochem. Parasitol.*, **140**: 87–96.
- Dietz, K.J., Jacob, S., Oelze, M.L., Laxa, M., Tognetti, V., de Miranda, S.M., Baier, and Finkemeier, I., 2006, The function of peroxiredoxins in plant organelle redox metabolism. *J. Exp. Bot.*, **57**: 1697–1709.
- Dubuisson, M., Vander Stricht, D., Clippe, A., Etienne, F., Nauser, T., Kissner, R., Koppenol, W.H., Rees, J.F. and Knoops, B., 2004, Human peroxiredoxin 5 is a peroxynitrite reductase. *FEBS Lett.*, **571**: 161–165.
- Henkle-Dührsen, K. and Kampkötter, A., 2001. Antioxidant enzyme families in parasitic nematodes. *Mol. Biochem. Parasitol.*, **114**: 129–142.
- Higgins and Sharp, 1988, CLUSTAL: a package for performing multiple sequence alignment on a microcomputer. *Gene*, **73**: 237–244.
- Hofmann, B., Hecht H.H. and Flohé, L., 2002. Peroxiredoxins. *Biol. Chem.*, **383**: 347–364.
- Jaeger, T., Budde, H., Flohé, L., Menge, U., Singh, M., Trujillo, M. and Radi, R., 2004, Multiple thioredoxin-mediated routes to detoxify hydroperoxides in *Mycobacterium tuberculosis*. *Arch. Biochem. Biophys.* **423**: 182–191.
- Jacobson, F.S., Morgan, R.W., Christman, M.F. and Ames, B.N., 1989, An alkyl hydroperoxide reductase from *Salmonella typhimurium* involved in the defense of DNA against oxidative damage. Purification and properties. *J. Biol. Chem.*, **264**: 1488–1496.
- Jang, H.H., Lee, K.O., Chi, Y.H., Jung, B.G., Park, S.K., Park, J.H., Lee, J.R., Lee, S.S., Moon, J.C., Yun, J.W., Choi, Y.O., Kim W.Y., Kang J.S., Cheong G.W., Yun D.J., Rhee S.G., Cho M.J. and Lee SY. 2004, Two enzymes in one; two yeast peroxiredoxins display oxidative stress-dependent switching from a peroxidase to a molecular chaperone function. *Cell*, **117**: 625–635.
- Jeon, S.J. and Ishikawa, K., 2003, Characterization of novel hexadecameric thioredoxin peroxidase from *Aeropyrum pernix* K1. *J. Biol. Chem.*, **278**: 24174–24180.
- Jeong, W., Cha, M.K. and Kim, I.H., 2000, Thioredoxin-dependent hydroperoxide peroxidase activity of bacterioferritin comigratory protein (BCP) as a new member of the thiol-specific antioxidant protein (TSA)/alkyl hydroperoxide peroxidase C (AhpC) family. *J. Biol. Chem.*, **275**: 2924–2930.
- Jeong, W., Park, S.J., Chang, T.S., Lee, D.Y. and Rhee, S.G., 2006, Molecular mechanism of the reduction of cysteine sulfenic acid of peroxiredoxin to cysteine by mammalian sulfiredoxin. *J. Biol. Chem.*, **281**: 14400–14407.
- Kang, S. W., Baines, I.C. and Rhee, S.G., 1998, Characterization of a mammalian peroxiredoxin that contains one conserved cysteine. *J. Biol. Chem.*, **273**: 6303–6311.
- Kawakami, R., Sakuraba, H., Kamohara, S., Goda, S., Kawarabayasi, Y. and Oshima, T., 2004, Oxidative stress response in an anaerobic hyperthermophilic archaeon: presence of a functional peroxiredoxin in *Pyrococcus horikoshii*. *J. Biochem.*, **136**: 541–547.
- Kim, K.; Kim, I.; Lee, K.Y.; Rhee, S.G. and Stadtman, E.R., 1988, The isolation and purification of a specific “protector” protein which inhibits enzyme inactivation by thiol/Fe(III)/O<sub>2</sub> mixed-function oxidation system. *J. Biol. Chem.*, **263**: 4704–4711.
- Kim S.J., Woo J.R., Hwang Y.S., Jeong D.G., Shin D.H., Kim K. and Ryu S.E., 2003, The tetrameric structure of *Haemophilus influenzae* hybrid Prx5 reveals interactions between electron donor and acceptor proteins. *J. Biol. Chem.* **278**: 10790–10798.
- Knoops, B., Clippe, A., Bogard, C., Arsalane, K., Wattiez, R., Hermans, C., Duconseille, E., Falmagne, P. and Bernard, A., 1999, Cloning and characterization of AOEB166, a novel mammalian antioxidant enzyme of the peroxiredoxin family. *J. Biol. Chem.* **274**: 30451–30458.
- Lee, T. H., Kim, S.U., Yu, S. L., Kim, S. H., Park do, S., Moon, H. B., Dho, S. H., Kwon, K. S., Kwon, H. J., Han, Y. H., Jeong, S., Kang, S. W., Shin, H. S., Lee, K. K., Rhee, S. G. and Yu. D.Y., 2003, Peroxiredoxin II is essential for sustaining life span of erythrocytes in mice. *Blood*, **101**: 5033–5038.
- Leyens, G., Donnay, I. and Knoops, B., 2003, Cloning of bovine peroxiredoxins-gene expression in bovine tissues and amino acid sequence comparison with rat, mouse and primate peroxiredoxins. *Comp. Biochem. Physiol. Part B.*, **136**: 943–955.

- Limauro, D., Pedone, E., Pirone, L. and Bartolucci, S., 2006, Identification and characterization of 1-Cys peroxiredoxin from *Sulfolobus solfataricus* and its involvement in the response to oxidative stress. *FEBS J.*, **273**: 721–731.
- Link, A.J., Robison, K. and Church, G.M., 1997, Comparing the predicted and observed properties of proteins encoded in the genome of *Escherichia coli* K-12. *Electrophoresis*, **18**: 1259–1313.
- Liu, X.P., Liu, X.Y., Zhang, J., Xia, Z.L., Liu, X., Qin, H.J. and Wang, D.W., 2006, Molecular and functional characterization of sulfiredoxin homologs from higher plants. *Cell Res.*, **16**: 287–296.
- Manevich Y., Feinstein S.I. and Fisher A.B., 2004, Activation of the antioxidant enzyme 1-CYS peroxiredoxin requires glutathionylation mediated by heterodimerization with pi GST. *Proc. Natl. Acad. Sci. USA.*, **101**: 3780–3785.
- Mizohata, E., Sakai, H., Fusatomi, E., Terada, T., Murayama, K., Shirouzu, M. and Yokohaya, S., 2005, Crystal structure of an archaeal peroxiredoxin from the aerobic hyperthermophilic crenarchaeon *Aeropyrum pernix* K1. *J. Mol. Biol.*, **354**: 317–329.
- Neumann, C.A., Krause, D.S., Carman, C.V., Das, S., Dubey, D.P., Abraham, J.L., Bronson, R.T., Fujiwara, Y., Orkin, S.H. and Van Etten, R.A., 2003, Essential role for the peroxiredoxin Prdx1 in erythrocyte antioxidant defence and tumour suppression. *Nature*, **424**: 561–565.
- Park, S.G., Cha, M.K., Jeong, W. and Kim, I.H., 2000, Distinct physiological functions of thiol peroxidase isoenzymes in *Saccharomyces cerevisiae*. *J. Biol. Chem.*, **275**: 5723–5732.
- Pauwels, F., Vergauwen, B., Vanrobaeys, F., Devreese, B. and Van Beeumen, J.J., 2003, Purification and characterization of a chimeric enzyme from *Haemophilus influenzae* Rd that exhibits glutathione-dependent peroxidase activity. *J. Biol. Chem.*, **278**: 16658–16666.
- Peterson, T.M. and Luckhart, S., 2006, A mosquito 2-Cys peroxiredoxin protects against nitrosative and oxidative stresses associated with malaria parasite infection. *Free Radic. Biol. Med.*, **40**: 1067–1082.
- Prosperi, M.T., Ferbus, D., Karczinski, I. and Goubin, G., 1993, A human cDNA corresponding to a gene overexpressed during cell proliferation encodes a product sharing homology with amoebic and bacterial proteins. *J. Biol. Chem.*, **268**: 11050–11056.
- Radyuk, S.N., Sohal, R.S. and Orr, W.C., 2003, Thioredoxin peroxidases can foster cytoprotection or cell death in response to different stressors: over- and under-expression of thioredoxin peroxidase in *Drosophila* cells. *Biochem. J.*, **371**: 743–752.
- Radyuk, S.N., Klichko, V.I., Spinola, B., Sohal, R.S. and Orr, W.C., 2001, The peroxiredoxin gene family in *Drosophila melanogaster*. *Free Radic. Biol. Med.*, **31**: 1090–1100.
- Rahlfs, S., Schirmer, R.H. and Becker, K., 2002, The thioredoxin system of *Plasmodium falciparum* and other parasites. *Cell. Mol. Life Sci.*, **59**: 1024–1041.
- Rhee, S.G., Chae, H.Z. and Kim, K., 2005, Peroxiredoxins: a historical overview and speculative preview of novel mechanisms and emerging concepts in cell signaling. *Free Radic. Biol. Med.*, **38**: 1543–1552.
- Rhee, S.G., Kang, S.W., Jeong, W., Chang, T.S., Yang, K.S. and Woo, H.A., 2005, Intracellular messenger function of hydrogen peroxide and its regulation by peroxiredoxins. *Curr. Opin. Cell Biol.*, **17**: 183–189.
- Rouhier, N. and Jacquot, J.P., 2005, The plant multigenic family of thiol peroxidases. *Free Radic. Biol. Med.*, **38**: 1413–1421.
- Sarma, G.N., Nickel, C., Rahlfs, S., Fischer, M., Becker, K. and Karplus, P.A., 2005, Crystal structure of a novel *Plasmodium falciparum* 1-Cys peroxiredoxin. *J. Mol. Biol.*, **346**: 1021–1034.
- Saitou, N. and Nei, M., 1987, The neighbor-joining method: a new method for reconstructing phylogenetic trees. *Mol. Biol. Evol.*, **4**: 406–425.
- Seaver, L.C. and Imlay, J.A., 2001, Alkyl hydroperoxide reductase is the primary scavenger of endogenous hydrogen peroxide in *Escherichia coli*. *J. Bacteriol.*, **183**: 7173–7181.
- Seo, M.S., Kang, S.W., Kim, K., Baines, I.C., Lee, T.H. and Rhee, S.G., 2000, Identification of a new type of mammalian peroxiredoxin that forms an intramolecular disulfide as a reaction intermediate. *J. Biol. Chem.*, **275**: 20346–20354.
- Verdoucq, L., Vignols, F., Jacquot, J.P., Chartier, Y. and Meyer, Y., 1999, In vivo characterization of a thioredoxin h target protein defines a new peroxiredoxin family. *J. Biol. Chem.*, **274**: 19714–19722.
- Vergauwen, B., Pauwels, F., Jacquemotte, F., Meyer, T.E., Cusanovich, M.A., Bartsch, R.G. and Van Beeumen, J.J., 2001, Characterization of glutathione amide reductase from *Chromatium gracile*.

- Identification of a novel thiol peroxidase (Prx/Grx) fueled by glutathione amide redox cycling. *J. Biol. Chem.*, **276**: 20890–20897.
- Wang, X., Phelan, S.A., Forsman-Semb K., Taylor, E.F., Petros, C., Brown, A., Lerner, C.P. and Paigen, B., 2003, Mice with targeted mutation of peroxiredoxin 6 develop normally but are susceptible to oxidative stress. *J. Biol. Chem.*, **278**: 25179–25190.
- Wong, C.M., Siu, K.L. and Jin, D.Y., 2004, Peroxiredoxin-null yeast cells are hypersensitive to oxidative stress and are genomically unstable. *J. Biol. Chem.*, **279**: 23207–23213.
- Wood, Z.S., Schröder, E., Robbin Harris, J. and Poole, L.B., 2003a, Structure, mechanism and regulation of peroxiredoxins. *Trends Biochem. Sci.* **28**: 32–40.
- Wood, Z.A., Poole, L.B. and Karplus, P.A., 2003b, Peroxiredoxin evolution and the regulation of hydrogen peroxide signaling. *Science*, **300**: 650–653.
- Yano, K., Komaki-Yasuda, K., Kobayashi, T., Takemae, H., Kita, K., Kano, S. and Kawazu, S., 2005, Expression of mRNAs and proteins for peroxiredoxins in *Plasmodium falciparum* erythrocytic stage. *Parasitol. Int.*, **54**: 35–41.

## CHAPTER 3

# STRUCTURAL SURVEY OF THE PEROXIREDOXINS

P. ANDREW KARPLUS AND ANDREA HALL

*Department of Biochemistry and Biophysics, Oregon State University, Corvallis, OR 97331*

**Abstract:** Peroxiredoxins (Prxs) are ubiquitous proteins that use an active site Cys residue to reduce hydroperoxides. Structural studies since the first Prx structure was determined in 1998 have produced 35 crystal structures of wild type and mutant Prxs with at least one representative structure from each of the five major evolutionary subfamilies of Prxs. These structures have yielded a great deal of knowledge about Prx structure and structure-function relations, revealing fascinating variations in quaternary structure and details of the fully-folded and locally-unfolded conformations that are involved in the catalytic cycle of all Prxs

**Keywords:** Protein structure, Peroxiredoxin families, Local unfolding, Conformational change, Active site

### 1. SCOPE AND PURPOSE

A protein's function flows directly from its structure, and for this reason knowledge of the three-dimensional structures of proteins plays a crucial role in guiding our understanding of protein function at the molecular level. In this regard, structure encompasses not only a set of coordinates, but also the dynamic and energetic properties of a protein. Since this chapter on peroxiredoxin (Prx) structure is present in the context of a whole volume documenting biochemical, enzymatic, physiological and regulatory aspects of Prxs, this review will not be a full synthesis of structure-function relations of Prxs, as was recently provided by Wood *et al.* (2003b), but will highlight and synthesize the key aspects of what is known today about the Prx structures themselves. It is designed so that when read together with Chapters 2, 4 and 5, it will give a complete picture of Prx structure-function relations. Also, whereas all of the currently known Prx structures will be cataloged here, it is not possible in this review to capture all of the ideas and insights that are present in the reports that describe these Prx structures in the original literature, so readers are encouraged to dig into the original structure reports (see citations in Table 1) in order to benefit from the descriptions and insights they have to offer.

Table 1. Deposited crystal structures of Prxs<sup>a</sup>

	Structure	Oligomer state	Interface type	Redox <sup>b</sup> State	Conformation <sup>c</sup>	Mutation	PDB code	Resolution (Å)	Reference
<b>PrxI</b>									
1	HsPrxII	( $\alpha_2$ ) <sub>5</sub>	BA	51SO <sub>2</sub> H172	FF	–	IQMV	1.7	(Schröder <i>et al.</i> , 2000)
2	RnPrxI	$\alpha_2$	B <sup>d</sup> (A)	52SS173	LU <sub>prxI</sub> <sup>1/2</sup>	C83S	IQO2	2.6	(Hirotsu <i>et al.</i> , 1999)
3	BtPrxIII	( $\alpha_2$ ) <sub>6</sub> <sup>e</sup>	BA	47SH168	FF	C168S	IZYE	3.3	(Cao <i>et al.</i> , 2005)
4	TcTXNPx	( $\alpha_2$ ) <sub>5</sub>	BA	52SH173	FF	–	IUUL	2.8	(Pinneyro <i>et al.</i> , 2005)
5	CfTryp	( $\alpha_2$ ) <sub>5</sub>	BA	52SH173	LU <sub>prxI</sub>	–	IE2Y	3.2	(Alphey <i>et al.</i> , 2000)
6	HpAhpC	( $\alpha_2$ ) <sub>5</sub>	BA	49SS169	LU <sub>prxI</sub>	–	IZOF	2.95	(Papinutto <i>et al.</i> , 2005)
7	Pv2Cys	( $\alpha_2$ ) <sub>5</sub>	BA	50SS170	LU <sub>prxI</sub>	–	2H66	2.5	Unpublished
8	PyPrxI	( $\alpha_2$ ) <sub>4</sub>	BA	44SH164	LU <sub>prxI</sub>	–	2H01	2.3	Unpublished
9	MtAhpC	( $\alpha_2$ ) <sub>6</sub>	BA	61SS174	LU <sub>prxI</sub> <sup>1/2</sup>	C176S	2BMX	2.4	(Guimaraes <i>et al.</i> , 2005)
10	StAhpC	( $\alpha_2$ ) <sub>5</sub>	BA	46SS165	LU <sub>prxI</sub>	–	1YEP	2.5	(Wood <i>et al.</i> , 2002)
11	StAhpC	( $\alpha_2$ ) <sub>5</sub>	BA	46SS165	LU <sub>prxI</sub>	T77D	1YEX	2.3	(Parsonage <i>et al.</i> , 2005)
12	StAhpC	( $\alpha_2$ ) <sub>5</sub>	BA	46SS165	LU <sub>prxI</sub>	T77I	1YF0	2.5	(Parsonage <i>et al.</i> , 2005)
13	StAhpC	( $\alpha_2$ ) <sub>5</sub>	BA	46SS165	LU <sub>prxI</sub>	T77V	1YF1	2.6	(Parsonage <i>et al.</i> , 2005)
14	StAhpC	( $\alpha_2$ ) <sub>5</sub>	BA	46SH <sup>f</sup> 165	FF	C46S	IN8J	2.17	(Wood <i>et al.</i> , 2003)
15	AxAhpC	( $\alpha_2$ ) <sub>5</sub>	BA	47SS166	LU <sub>prxI</sub>	–	IWE0	2.9	(Alphey <i>et al.</i> , 2000)
<b>Prx6</b>									
16	HsPrxVI	$\alpha_2$	B	47SOH	FF	C91S	IPRX	2.0	(Choi <i>et al.</i> , 1998)
17	Py1Cys	$\alpha_2$	B	47SH	FF	–	IXCC	2.3	Unpublished
18	ApTpx	( $\alpha_2$ ) <sub>5</sub>	BA	50SO <sub>3</sub> H213	FF	–	2CV4	2.3	(Mizohata <i>et al.</i> , 2005)
19	ApTpx	( $\alpha_2$ ) <sub>5</sub>	BA	50SH213	FF	C207S	1X0R	2.0	(Nakamura <i>et al.</i> , 2006)
<b>Prx5</b>									
20	HsPrxV	$\alpha_2$	A	47SH151	FF	–	IH40	1.95	Unpublished
21	HsPrxV	$\alpha_2^g$	A	47SH151	FF	–	IHD2	1.5	(Declercq <i>et al.</i> , 2001)
22	HsPrxV	$\alpha_2$	A	47SS151	LU <sub>prx5</sub>	–	IOC3	2.0	(Evrard <i>et al.</i> , 2004)
23	HsPrxV	$\alpha_2$	A	47SH <sup>f</sup> 151	FF	C47S	IURM	1.7	(Evrard <i>et al.</i> , 2004)
24	PtPrxD	$\alpha_2$	A	51SH	FF	–	ITP9	1.62	(Echalier <i>et al.</i> , 2005)
25	H/HyPrxV	$\alpha_2^h$	A	49SH	LU <sub>prx5</sub>	–	INM3	2.8	(Kim <i>et al.</i> , 2003)
26	PfAOP	$\alpha_2$	A	59SO <sub>3</sub> H	FF	–	IXIY	1.8	(Sarma <i>et al.</i> , 2005)



<b><i>Tpx</i></b>									
27	<i>EcTpx1</i>	$\alpha_2$	A	61SS95	LU <sub>TPX</sub>	-	1QXH	2.2	(Choi <i>et al.</i> , 2003)
28	<i>HtTpx</i>	$\alpha_2$	A	59SS93	LU <sub>TPX</sub>	-	1Q98	1.9	Unpublished
29	<i>MtTpx</i>	$\alpha_2$	A	60SH <sup>1</sup> 93	FF	C60S	1Y25	2.1	(Stehr <i>et al.</i> , 2006)
30	<i>SpTpx</i>	$\alpha_2$	A	58SH92	FF	-	1PSQ	2.3	Unpublished
<b><i>BCP</i></b>									
31	<i>ApBCP</i>	$\alpha_2$	A	49SH/SS54	FF/LU <sub>BCP</sub>	-	2CX4	2.3	Unpublished
32	<i>ApBCP</i>	$\alpha_2$	A	49SS54	LU <sub>BCP</sub>	-	2CX3	2.6	Unpublished
33	<i>ScnTPx</i>	$\alpha$	-	107SH <sup>1</sup> 112	FF	C107S/C112S	2A4V	1.8	(Choi <i>et al.</i> , 2005)
???									
34	<i>MtAhpE</i>	$\alpha_2^j$	A	45SH	FF	-	1XXU	1.9	(Li <i>et al.</i> , 2005)
35	<i>MtAhpE</i>	$\alpha_2^j$	A	45SOH	FF	-	1XVW	1.87	(Li <i>et al.</i> , 2005)

<sup>a</sup> Organism abbreviations are as follows:

*Ap*=*Aeropyrum pernix*; *Ax*=*Amphibacillus xylanus*; *Bt*=*Bos taurus*; *Cf*=*Crithidia fasciculata*; *Ec*=*Escherichia coli*; *Ht*=*Haemophilus influenzae*; *Hp*=*Helicobacter pylori*; *Hs*=*Homo sapiens*; *Mt*=*Mycobacterium tuberculosis*; *Pf*=*Plasmodium falciparum*; *Pt*=*Populus trichocarpa*; *Pv*=*Plasmodium vivax*; *Py*=*Plasmodium yoelii*; *Rn*=*Rattus norvegicus*; *Sc*=*Saccharomyces cerevisiae*; *Sp*=*Streptococcus pneumoniae*; *St*=*Salmonella typhimurium*; *Tc*=*Trypanosoma cruzi*

<sup>b</sup> The redox state of C<sub>p</sub> is given as well as the residue numbers of C<sub>p</sub> and, for 2-Cys Prxs, C<sub>R</sub>.

<sup>c</sup> The conformation of the active site is indicated as FF for fully-folded and LU with subscripts for the kinds of local unfolding seen in various subfamilies (see Figure 5).

<sup>d</sup> This disulfide form shows only the stable B-type dimer, but the protein is believed to be a BA decamer in the reduced state.

<sup>e</sup> A concatameric interaction of the dodecamers is believed to be an artifact of crystallization.

<sup>f</sup> A Cys → Ser mutant of C<sub>p</sub> mimics the reduced state.

<sup>g</sup> Originally described as a monomer when published by the authors but later acknowledged as A-type dimer (Evrard *et al.*, 2004).

<sup>h</sup> The glutaredoxin domains interact to make the protein a dimer of dimers.

<sup>i</sup> *MtAhpE* does not clearly fit into any of the designated subfamilies and so has been set apart.

<sup>j</sup> The authors described the structures as an ( $\alpha_2$ )<sub>4</sub> octamer, but we suspect (see text) the octamer is an artifact of high protein concentration. Also, the FF form in entry 1XXU is as seen for other subfamilies, but that in 1XVW is slightly different.

## 2. INTRODUCTION

As first recognized in 1994 (Chae *et al.*, 1994) Prxs are a widely distributed family of peroxide reducing enzymes that evidence suggests have evolved from an ancestor protein having the thioredoxin fold (Copley *et al.*, 2004). All of the known Prx sequences share recognizable similarities, including an absolutely conserved Cys residue (called the peroxidatic Cys) that is involved directly in the reduction of the substrate hydroperoxides. As outlined in Chapter 2, the known Prx sequences can be organized into five major subfamilies, each constituting a group of proteins that are more similar to each other than to the other Prxs. This grouping based on sequence similarity is most useful here because the level of structural similarity observed between two homologous proteins is generally related to their level of sequence similarity (Chothia and Lesk, 1986). For the sake of consistency, we will here use the nomenclature introduced in Chapter 2, with the five subfamilies being referred to as Prx1, Prx6, Prx5, Tpx and BCP (shortened from BCP/PrxQ). In terms of the Prxs from humans, subfamily Prx1 contains human PrxI, II, III and IV, subfamily Prx6 contains PrxVI, and subfamily Prx5 contains PrxV. Subfamily Tpx contains only bacterial Prxs and subfamily BCP contains bacterial and plant (PrxQ) Prxs. Subfamilies Prx1 and Prx6 are listed next to each other as they are similar enough to each other that in some reports they are grouped into a single subfamily (e.g. Copley *et al.*, 2004).

It is wise to be cautious about assigning a particular Prx to a subfamily just based on the common name of the enzyme, because many individual Prxs were named based on their activities before it was known which ones were most similar to each other. For example, within the Prx1 subfamily individual enzymes have a variety of common names ranging as widely as PrxI, PrxII, PrxIII, PrxIV, Tsa1, PrxA, PrxB, Tpx1, and AhpC. In terms of labels based on mechanism, all “typical 2-cys” Prxs are in the Prx1 and Prx6 subfamilies, while “atypical 2-Cys Prxs”, and “1-Cys Prxs” are not associated with any family in particular, but are distributed among a variety of families (see section 6.2 below).

## 3. UNIVERSAL FEATURES OF THE PRX CATALYTIC CYCLE

A combination of structural and enzymatic studies has revealed that all Prxs have in common a catalytic cycle that includes a crucial conformational step as well as (at least) three chemical steps (Figure 1). Throughout this Chapter, the Cys that directly reduces peroxide will be referred to as the peroxidatic Cys, using  $S_p$  to designate the sulfur atom of the Cys side chain and using  $C_p$  to designate the residue. Similarly, the resolving thiol, the thiol that forms a disulfide with  $C_p$ , will be designated by  $S_R$  for the sulfur atom and  $C_R$  for the residue if it is a Cys.

As seen in Figure 1, the catalytic cycle begins with the peroxide substrate (either an alkyl hydroperoxide or hydrogen peroxide) entering the fully-folded substrate binding pocket and reacting with the peroxidatic Cys ( $C_p$ ) at the base of this pocket. In chemical step 1, the peroxide substrate is reduced to its corresponding alcohol and

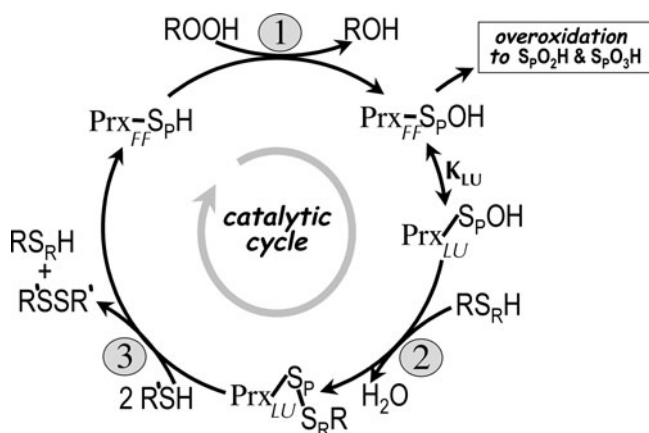

Figure 1. The universal catalytic cycle of Prxs. The three main chemical steps of (1) peroxidation, (2) resolution, and (3) recycling are shown along with an explicit local unfolding step required for the resolution reaction. S<sub>P</sub> and S<sub>R</sub> designate the sulfur atoms of the peroxidatic and resolving thiols, respectively. The fully-folded and locally-unfolded enzyme conformations are designated as FF and LU, respectively. See the text for further details

C<sub>P</sub> becomes oxidized to the sulfenic acid form (S<sub>P</sub>OH). Resolution (step 2) occurs when a free thiol (S<sub>R</sub>H) attacks the S<sub>P</sub>OH to release water and form a disulfide. This attacking thiol, whether present on the same or another subunit of the Prx, is referred to as the resolving thiol, as it resolves a potential block of the catalytic cycle resulting from the poor accessibility of C<sub>P</sub> by the bulky natural substrate. Because in the fully-folded enzyme C<sub>P</sub> is located in a protected active site pocket, resolution cannot occur without a conformational change that involves (at a minimum) the local unfolding of the active site pocket so as to make the C<sub>P</sub> side chain much more accessible. It is expected that the locally-unfolded and fully-folded conformations of the protein are in a dynamic equilibrium, governed by the equilibrium constant K<sub>LU</sub> that may differ for different Prxs and for the various redox states of each Prx. Because disulfide formation involves the adduction to C<sub>P</sub> of a large group, the disulfide forms of Prxs cannot adopt the fully-folded conformation, but remain locked into a locally-unfolded conformation. The reaction cycle is completed when the disulfide form is recycled to regenerate the peroxidatic and resolving thiols (step 3), and the Prx is freed to again adopt the fully-folded peroxidatic active site. In principle, recycling may involve protein or small molecule thiols. For many Prxs this step is known to involve a thioredoxin-like dithiol containing protein or domain (see Chapter 4).

While it is not part of the normal productive catalytic cycle, in competition with the resolution reaction is an overoxidation reaction (Figure 1). In this side reaction, the fully-folded S<sub>P</sub>OH form reacts with a second molecule of peroxide to form a sulfinic acid (S<sub>P</sub>O<sub>2</sub>H) and in certain Prxs this can further react with a third peroxide substrate to yield a terminally oxidized sulfonic acid (S<sub>P</sub>O<sub>3</sub>H) form.

As discussed by Sarma *et al.* (2005), the terminal state for a given Prx appears to be governed by details of the active site geometry. In any case, neither of these “overoxidized” forms can be readily converted to a disulfide and thus represent inactive forms of the enzyme, although the  $S_pO_2H$  form of certain eukaryotic Prxs is thought to be physiologically relevant in peroxide signal transduction (Wood *et al.*, 2003; Immenschuh *et al.*, 2005; Kang *et al.*, 2005; Chapters 14 & 15) and can be resurrected to  $S_pOH$  in an ATP dependent reaction (Biteau *et al.*, 2003; Woo *et al.*, 2003; Chang *et al.*, 2004). The structural studies summarized in the next section reveal not only representative fully-folded and locally unfolded structures for various Prx subfamilies, but also interesting variations in quaternary structure that add complexity to the structure-function relations.

#### 4. SUMMARY OF STRUCTURAL INVESTIGATIONS

Since the first Prx crystal structure was reported in 1998 (Choi *et al.*, 1998), the field has rapidly matured so that as of July 2006, as summarized in Table 1, 35 crystal structures of Prxs are available in the Protein Data Bank (Berman *et al.*, 2000). Although three Prxs from the Prx5 subfamily have been analyzed by NMR to the point of making resonance assignments (Trivelli *et al.*, 2003; Bouillac *et al.*, 2004; Echaliier *et al.*, 2005), no complete NMR-derived structures are in the protein Data Bank. The 35 available structures represent the wild type and/or mutant forms of 25 distinct Prxs, including at least one representative from each Prx subfamily: eleven from subfamily Prx1, three from subfamily Prx6, four from subfamily Prx5, five from subfamily Tpx, and two from subfamily BCP. Eight of the structures, some of which are derived from structural genomics projects, have not yet been described in a publication in the original literature. In terms of the redox state of the peroxidatic Cys residue, all possibilities have been seen from SH, SOH,  $SO_2H$ ,  $SO_3H$  and SS, although in only three cases, those of AhpC from *Salmonella typhimurium* (subfamily Prx1), human PrxV (subfamily Prx1), and a BCP from *Aeropyrum pernix* have both SH and SS states been observed for the same protein.

#### 5. STRUCTURAL FEATURES COMMON TO ALL PRXS

##### 5.1. Overall Structure

At the topology level, all Prxs have core tertiary structures that are highly spatially conserved (Figure 2a) with variations in loop lengths and conformations and N- and C-terminal extensions. When schematized, the core structure can be seen to include 7  $\beta$ -strands and 5  $\alpha$ -helices, which are organized as a central 5-stranded antiparallel  $\beta$ -sheet, including strands  $\beta_5$ - $\beta_4$ - $\beta_3$ - $\beta_6$ - $\beta_7$ , with one face of the sheet covered by  $\beta_1$ - $\beta_2$ - $\alpha_1$  and  $\alpha_4$  and the other face of the sheet covered by  $\alpha_2$ ,  $\alpha_3$  and  $\alpha_5$  (Figure 2b). Because strand  $\beta_5$  has some interaction with strand  $\beta_1$ , the central sheet is sometimes referred to as a single 7-stranded sheet rather than a 5-stranded

(a)



(b)

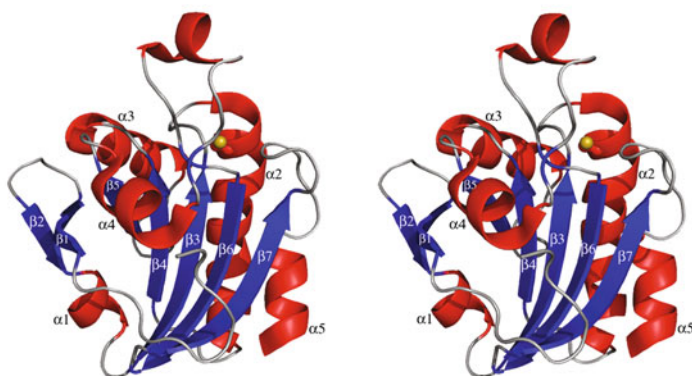

*Figure 2.* The Prx fold. (a) An overlay of all 19 fully-folded Prx structures indicating the conservation of the core of the fold. Colored by mobility with deep blue representing the least mobile portions of the chain and bright red representing the most mobile portions. (b) Stereoview of a representative fully-folded Prx (PDB code 1HD2) labeled to identify the common core  $\alpha$ -helices (red), and  $\beta$ -strands (blue) that are conserved among all Prx proteins. The peroxidatic cysteine in the first turn of helix  $\alpha 2$  is shown as a ball and stick with  $S_p$  in mustard yellow (See Plate 1)

sheet plus an additional 2-stranded  $\beta$ -hairpin. In the fully-folded conformation of Prxs (as shown in Figure 2) the  $C_p$ -residue is always located in the first turn of helix  $\alpha 2$ , and the unraveling of the first turn or two of this helix appears to be a universal feature of local unfolding.

In crystal structures, in addition to the coordinates, temperature factors (or B-factors) are derived for each atom. These values give information about the level of mobility of the structure, with larger values implying more disordered regions. In Figure 2a, the coloring of the Prx structure indicates the level of order, with a color gradient extending from the less mobile portions being blue to the most mobile portions being red. Figure 2a makes it very clear that surface loops are in general the most mobile parts of the structure, and these are also the regions that vary most in conformation and in the presence of insertions and deletions.

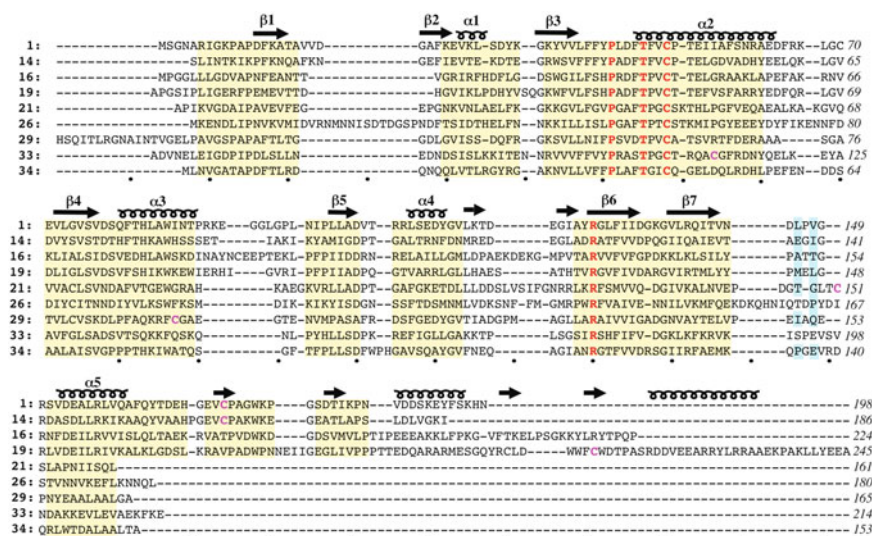
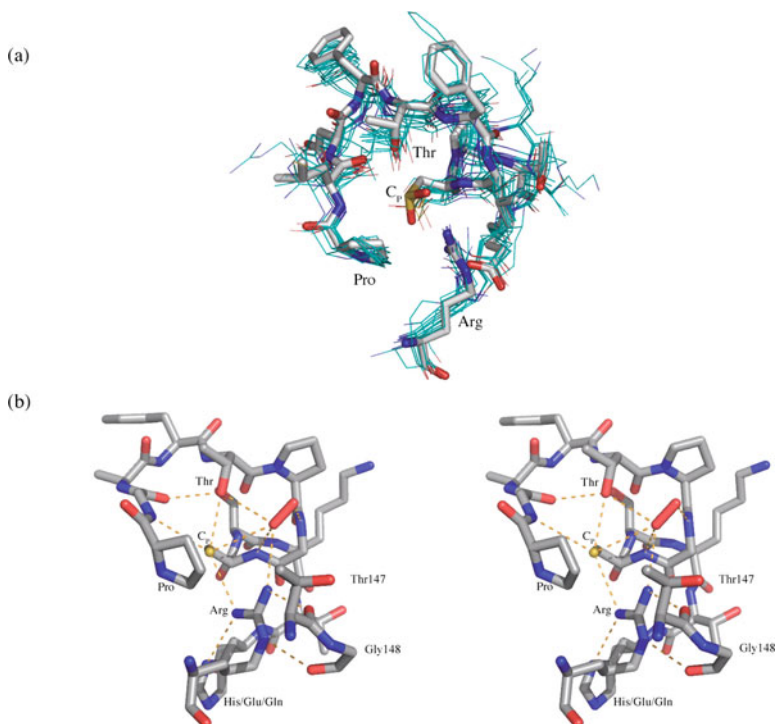

**Figure 3.** Structure based sequence alignment of representative Prxs. Regions of common main-chain path are highlighted by a tan background. Secondary structure elements are indicated by coils ( $\alpha$ -helices,  $3_{10}$ -helices) and arrows ( $\beta$ -strands) above the sequence, and core elements are labeled as in figure 2b. Four residues absolutely conserved are colored red and  $C_R$  of 2-Cys Prxs are colored violet. Residues involved in passing chain stabilization of the active site Arg are highlighted by a cyan background. Structures are referenced by index number from Table 1 and include in order a sensitive Prx1, a robust Prx1, a 1-Cys Prx6, a 2-Cys Prx6, a 2-Cys Prx5, a 1-Cys Prx5, a Tpx, a BCP, and the difficult to classify *MtAhpE*. Reference residue numbers are at the end of each line and for convenience, dots below the sequence blocks mark every ten spaces. Structure based sequence alignment was aided by the use of Sequoia (Bruns *et al.*, 1999) (See Plate 2)

Figure 3 presents a structure-based sequence alignment that includes representative Prxs from each of the five subfamilies. This alignment reveals in a different way how insertions and deletions in the various families are generally located between the common core secondary structural elements.

## 5.2. The Fully-folded Peroxidatic Active Site

As was noted above, in the fully-folded enzyme the peroxidatic active site is located in a pocket with the  $C_P$  residue present in the first turn of helix  $\alpha_2$ . A comparison of the active sites of all of the fully-folded structures (Figure 4a) shows that the geometry of this region is highly conserved despite the broad sequence diversity represented among the five subfamilies. In addition to the peroxidatic Cys, there are a Pro, a Thr and an Arg that are absolutely conserved in known Prx sequences (Figure 3). These three residues are all located directly in the fully-folded peroxidatic active site and are in van der Waals contact with  $C_P$  (Figure 4b). The high structural conservation of the active site among Prxs means that one structure can be used to represent the



**Figure 4.** The peroxidatic active site of Prxs. (a) An overlay of fully-folded Prx structures (thin lines with atom coloring C=cyan, N=blue, O=red, S=mustard) to indicate the high conservation of the peroxidatic active site geometry. Included are residues in the segment surrounding  $C_p$  and the conserved Arg. PDB entry IQMV is modeled as sticks with atom coloring (C=grey, N=blue, O=red, S=yellow). (b) Stereoview of the fully-folded active site of human PrxV (Declercq *et al.*, 2001), the highest resolution structure (PDB code 1HD2). This active site has a bound molecule of benzoate, and in this figure, we have inserted a peroxide molecule close to the positions occupied by the benzoate oxygens (see text). Potential H-bonding interactions (dashed lines) are shown. In addition to the residues shown in (a), two residues (Thr147 and Gly148) from the loop between strand  $\beta 7$  and helix  $\alpha 5$  are also included as they stabilize the Arg by their peptide oxygens. In Figure 3, the residues contributing equivalent carbonyls are highlighted with a cyan background. Although not seen in the BCP structure selected for Figure 3, the other BCP structure (PDB entry 2CX4) does conserve this feature (See Plate 3)

interactions common to all. Fortunately, the highest resolution image of the fully-folded active site as seen in human PrxV (Declercq *et al.*, 2001), has a bound molecule of benzoate, which we speculate binds as a substrate analog with the two carboxylate oxygens crudely mimicking the placement of the two oxygens of a peroxide substrate.

The interactions of various residues can be seen in Figure 4b. The conserved Arg is positioned by three H-bonds (one to a His conserved as His or Glu in most Prxs and two to peptide oxygens from the loop between strand  $\beta 7$  and helix  $\alpha 5$ ), while the other two H-bonds of the Arg point at  $S_p$  and the peroxide oxygen to be attacked. A second H-bond to  $S_p$  comes from the backbone amide located just after

the conserved Pro. The Thr residue has an interesting position where it approaches closely to both a benzoate oxygen and the backbone oxygen of the residue following the conserved Pro. Both of these atoms are H-bond acceptors so one of these close approaches is expected to be an unfavorable electrostatic repulsion, because normally Thr can only donate one H-bond. Two final important interactions are H-bonds from two peptide nitrogens in the first turn of helix  $\alpha_2$  to the benzoate oxygens.

The interactions seen support the idea that the benzoate is mimicking peroxide, although inaccurately, since the peroxide bond length is 1.4 Å while the O $\cdots$ O separation in benzoate is  $\sim$ 2.3 Å. The closer O $\cdots$ O separation in peroxide would allow it to make much better H-bonds to the two backbone amides. In terms of proposed roles for the three conserved residues, the Pro shields the C<sub>p</sub> from water and positions the peptide NH that contributes to C<sub>p</sub> activation, the Arg not only activates C<sub>p</sub>, but also influences the position and chemistry of the peroxide oxygen that will be attacked, and the Thr may play a role as a proton shuttle possibly between C<sub>p</sub> and/or the two oxygens of the peroxide. In addition, the peptide amide from C<sub>p</sub> and the residue preceding it play crucial roles in positioning the two oxygens of the peroxide, and stabilizing them as they separate during catalysis.

### 5.3. Local Unfolding of the Peroxidatic Active Site

Currently, structures are available for locally-unfolded disulfide bonded forms of four of the five Prx subfamilies; the one missing is subfamily Prx6. Although there are variations in the details of the local unfolding transition(s) of each subfamily, they all have in common an unraveling of the first turn of helix  $\alpha_2$  so that C<sub>p</sub> itself is no longer in a helix but is highly exposed in a loop segment (Figure 5). In

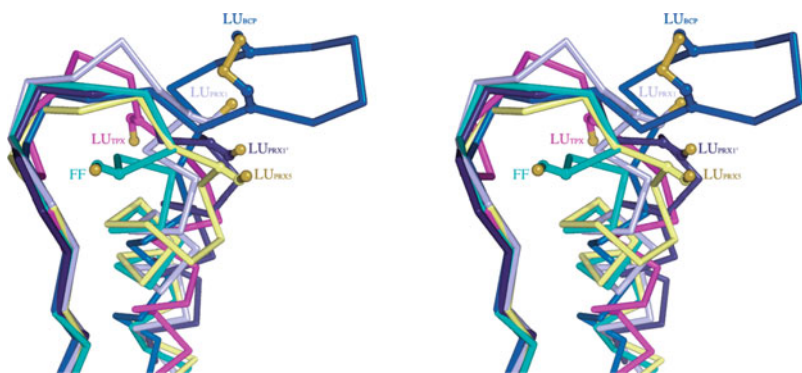

*Figure 5.* Local unfolding transitions of the peroxidatic active site region. Stereoview comparing the structure of the canonically fully-folded helix  $\alpha_2$  (cyan for PDB entry 1QMV) compared with a set of representative locally-unfolded C<sub>p</sub> loops: two from subfamily Prx1 (light purple for PDB entry 1YEX and dark purple for PDB entry 2BMX), and one each from subfamilies Prx5 (yellow for PDB entry 1OC3), Tpx (magenta for PDB entry 1QXH) and BCP (dark blue for PDB entry 2CX3). The C<sub>p</sub> residue is in each case shown as ball and stick with S<sub>p</sub> in mustard yellow. The LU structures are all involved in disulfide bonds even though the C<sub>R</sub> is only shown for the LU<sub>BCP</sub> case (See Plate 4)



Prx structure descriptions, this loop is sometimes referred to as the C<sub>p</sub>-loop (Wood *et al.*, 2002). Further aspects of the locally unfolded structures are unique to each subfamily, and so will be presented in the sections below.

## 6. FEATURES VARYING BETWEEN PRX SUBFAMILIES

### 6.1. Quaternary Structures

The peroxidative active site only includes residues from a single monomer, so in principle Prxs could be monomeric. Among structurally known Prxs, however, only one, the BCP from *Saccharomyces cerevisiae*, appears to be monomeric (entry #33, Table 1). The remaining ones have quaternary structures that include two distinct kinds of dimers, as well as octamers, decamers and dodecamers (Figure 6). To fit into this categorization, three Prxs require some additional explanation. First is the hybrid Grx-Prx from *Haemophilus influenza* (entry #25 in Table 1) which is actually tetrameric. We treat it here as dimeric because structurally it is made up of two dimeric Prxs that are joined to make a tetramer by dimerization interactions of the Grx domains of the protein (Kim *et al.*, 2003). Thus as far as the Prx interactions, it is dimeric. Second is *Mycobacterium tuberculosis* AhpE (entries #34 and #35 in Table 1) which was reported to be an octamer (Li *et al.*, 2005), but two reasons lead us to suspect that the octamer is an artifact of crystallization rather than a physiologically relevant state: Most importantly, gel filtration at high concentration showed the large majority of the protein was present as a dimer with only a little octamer present, and less conclusive but still of interest to note, the interface building the octamers was not very extensive and did not involve the known B-type interface (see section 6.1.1 below). The third structure requiring comment is the structure of *Bos taurus* PrxIII (entry #3 in Table 1) which in the crystal was seen to be a remarkable concatenated pair of dodecamers (Cao *et al.*, 2005). The authors opined that the concatenation was an artifact, and that the physiological state of the protein is a single dodecamer as was seen for *M. tuberculosis* AhpC (entry #9 in Table 1; Guimaraes *et al.*, 2005).

#### 6.1.1. A-type and B-type interfaces

All oligomeric Prxs are formed via associations involving only two distinct interfaces. One of these interfaces, as seen in Figure 6b, involves the edge to edge association of strands  $\beta$ 7 of the central  $\beta$ -sheet of two Prx chains to make an extended 10-stranded  $\beta$ -sheet (or a 14-stranded sheet if one considers the monomer topology to be a 7-stranded sheet). The other interface is a tip-to-tip association centered on helix  $\alpha$ 3 packing against its counterpart in the other chain. Following the suggestion of Sarma *et al.* (2005), we refer to these interfaces as the B-type interface (B for “ $\beta$ -sheet” based) and the A-type interface (A for “alternate” or for “ancestral”), respectively. Prxs with B-type interfaces have in common a C-terminal subdomain that reaches out across the two-fold axis to make extensive interactions that help stabilize the dimer. For more detailed descriptions of the A and B-type interfaces readers are referred to treatments in the original literature (Choi *et al.*,

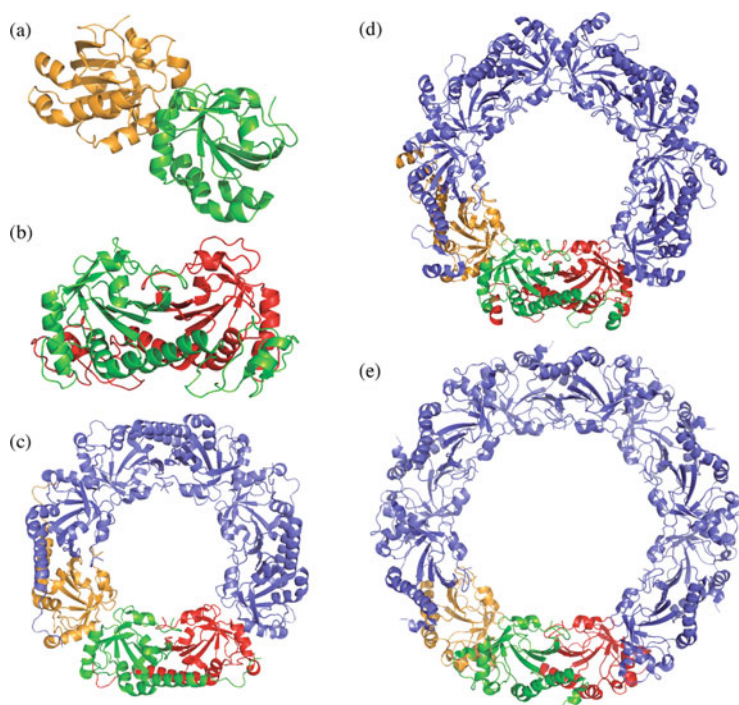

Figure 6. Quaternary structures of Prxs. Shown are representative structures of an (a) A-type dimer (PDB entry 1HD2), (b) B-type dimer (PDB entry 1PRX), (c) octamer (PDB entry 2H01), (d) decamer (PDB entry 1QMV) and (e) dodecamer (PDB entry 2BMX). Subunit coloring for the A-type dimer (gold and green) and the B-type dimer (green and red) are used in the higher order structures to show how they are built from these two types of interactions. The octamer, decamer and dodecamer are on the same scale and have inner diameters of  $\sim 50$  Å,  $\sim 60$  Å and  $\sim 70$  Å, respectively (See Plate 5)

1998; Wood *et al.*, 2002; Choi *et al.*, 2003; Echaliier *et al.*, 2005; Sarma *et al.*, 2005).

As seen in Table 1, both subfamilies Prx1 and Prx6 have dimeric Prxs with the B-type interface (Figure 6b), but subfamilies Prx5 and Tpx exist exclusively as A-type dimers (Figure 6a). One BCP subfamily structure appears to be monomeric (having no packing interactions in the crystal involving either the A- or B-type interface), but the other BCP representative has tight packing interactions in the crystals that involve the A-type interface, so we have tentatively identified it as an A-type dimer (Table 1). The relative orientation of subunits interacting via the A-type interface may differ by up to  $\sim 30^\circ$  among various Prxs (Sarma *et al.*, 2005). In terms of higher order oligomers, the octameric, decameric and dodecameric Prxs are exclusive to the Prx1 and Prx6 subfamilies and consist of four, five or six B-type dimers associating to form the higher order structure via A-type interfaces (Figure 6c,d,e). Comparisons reveal that the tighter ring structure of the octamer and the expanded ring structure of the dodecamer are due to shifts in the packing at

the B-type interface with the A-type interfaces being equivalent. We expect based on this that octameric, decameric, and dodecameric Prxs will function equivalently despite the difference in appearance; for simplicity, in the remainder of this review, any properties of decameric Prxs that are discussed are expected to refer equally well to octamers and dodecamers.

### 6.1.2. A linkage of decamer assembly and the catalytic cycle

As first shown by Wood *et al.* (2002) and since confirmed by Guimaraes *et al.* (2005), decameric Prxs have a redox-linked quaternary structure, with disulfide formation weakening decamer stability so that the disulfide form of the enzyme is present as B-type dimers (or mixtures of dimers and higher order oligomers) and all other forms of the enzyme ( $S_pH$ ,  $S_pOH$ ,  $S_pO_2H$ ,  $S_pO_3H$ ) expected to be present as stable decamers. The dimer-decamer equilibrium is also influenced somewhat by pH and ionic strength (Schröder *et al.*, 1998; Kitano *et al.*, 1999; Kristensen *et al.*, 1999; Schröder *et al.*, 2000; Chauhan and Mande, 2001; Papinutto *et al.*, 2005), but these factors are not expected to vary much *in vivo*. The proposed physical explanation for the linkage between disulfide formation and decamer disruption is that the fully-folded active site buttresses the decamer building (A-type) interface and when the local-unfolding of the active site is locked into place by disulfide formation, the decamer is destabilized (Wood *et al.*, 2002). Thus, during the catalytic cycle (Figure 1) these enzymes undergo a change from decamers to dimers and back to decamers again (Wood *et al.*, 2002). If correct, this explanation implies that for decameric Prxs enzymes, the stability of the fully-folded active site conformation (and hence catalytic activity) is linked to decamerization. This link was confirmed by a study showing that mutants of *S. typhimurium* AhpC that could not effectively form decamers were 100-fold less active than wild-type enzyme (Parsonage *et al.*, 2005). Since the A-type interface is most widespread among bacterial Prxs and because the A-type interface has some linkage to catalytic activity, Sarma *et al.* (2005) proposed that it is the more ancestral mode of association for Prxs.

## 6.2. Variations in the Presence and Placement of the Resolving Cys

The universal mechanism of Prxs (Figure 1) involves a single conserved peroxidatic Cys residue, but there is a diversity as to where the resolving Cys comes from. Prxs that do not contain a resolving Cys are called 1-Cys Prxs and for these enzymes the regeneration of the reduced  $C_p$  must be achieved by a different protein or small molecule reductant. Prxs that have a resolving Cys are called 2-Cys Prxs and are divided into two classes: “typical 2-Cys Prxs” are a narrow group with the resolving Cys coming from the other chain of a B-type dimer, and “atypical 2-Cys Prxs” are a broad grouping that includes all 2-Cys Prxs that are not “typical”. Known atypical 2-Cys Prxs have the resolving Cys positioned in one of three distinct places: Prx5 Prxs have it in the loop between strand  $\beta 7$  and helix  $\alpha 5$ , Tpx Prxs have it in helix  $\alpha 3$ , and BCP Prxs have it in helix  $\alpha 2$  just 5 residues beyond  $C_p$ . These

distinct placements of  $C_R$  imply that this family has an evolutionary history that involves multiple independent (convergent) conversions between 1-Cys and 2-Cys mechanisms, and that basically any place that can locally unfold to form a disulfide with  $C_P$  is a potential acceptable spot for  $C_R$ .

### 6.2.1. Subfamily Prx1: sensitive and robust varieties of typical 2-Cys Prxs

Prxs of the Prx1 subfamily form strong B-type dimers as their basic unit, stabilized by a C-terminal subdomain that associates strongly with the second domain of the dimer (Figure 6b). All enzymes assigned to this subfamily are typical 2-Cys Prxs with the  $C_R$  residue present in the C-terminal extension of the other chain of a B-type dimer. The  $C_R$  residue in these enzymes is buried within the folded C-terminal subdomain and is about 14 Å away from  $C_P$  in the fully-folded form (Figure 7a). Thus for resolution to occur in these enzymes, not only does the peroxidatic active site need to locally unfold to expose  $C_P$ , but the C-terminal subdomain must unfold to expose  $C_R$ . The result is that in the disulfide-bonded form of these enzymes the C-terminal extension becomes largely disordered and is generally not visible in the crystal structures (Figure 7a). In terms of the conformation of the locally unfolded  $C_P$ -loop, two variations have been seen, one that just involves unwinding of first turn of the helix (designated  $LU_{PRX1}$  in Figure 5) and a second that involves an additional shift in the direction of helix  $\alpha 2$  (designated  $LU_{PRX1}'$  in Figure 5). As described by Wood *et al.* (2002), the structure of the dimeric *R. norvegicus* PrxI (Hirotsu *et al.*, 1999) suggests that when the disulfide-bonded decamer dissociates into dimers, the  $C_P$ -loop undergoes a further conformational change to a more compact structure (designated  $LU_{PRX1}''$  in Table 1) that may enhance its ability to be recycled by thioredoxin or other reductant to regenerate the  $C_P$  and  $C_R$  thiols.

While all Prx1 subfamily enzymes share the above structural transitions, they can be subdivided into two distinct groups based on their sensitivity to the overoxidative inactivation shunt described earlier (Figure 1), which occurs when the active site  $S_P$ OH reacts with a second molecule of peroxide. Certain types of these enzymes, such as human PrxI and PrxII are sensitive to such inactivation while others, such as the various bacterial AhpC enzymes, are robust (Wood *et al.*, 2003b). The structural origin of this difference was discovered to be the presence in sensitive enzymes of a C-terminal helix that packed on top of the base of helix  $\alpha 2$  and hindered the local unfolding of the peroxidatic active site (Figure 8). With reference to Figure 1, it can be seen that if local unfolding is an unfavorable event (i.e.  $K_{LU}$  is small), then flow down the overoxidation shunt will be enhanced making the enzyme more sensitive to oxidative inactivation. This structural explanation has been biochemically confirmed by protein engineering of two Prxs from *Schistosoma mansoni* (Sayed *et al.*, 2004). To provide a rationale for why sensitivity to inactivation by peroxides has been selected for during evolution, Wood *et al.* (2003a) speculated that it allows these proteins to act as a peroxide floodgate to regulate hydrogen peroxide signaling in eukaryotes. This and other possible explanations are the subject of other Chapters in this volume.

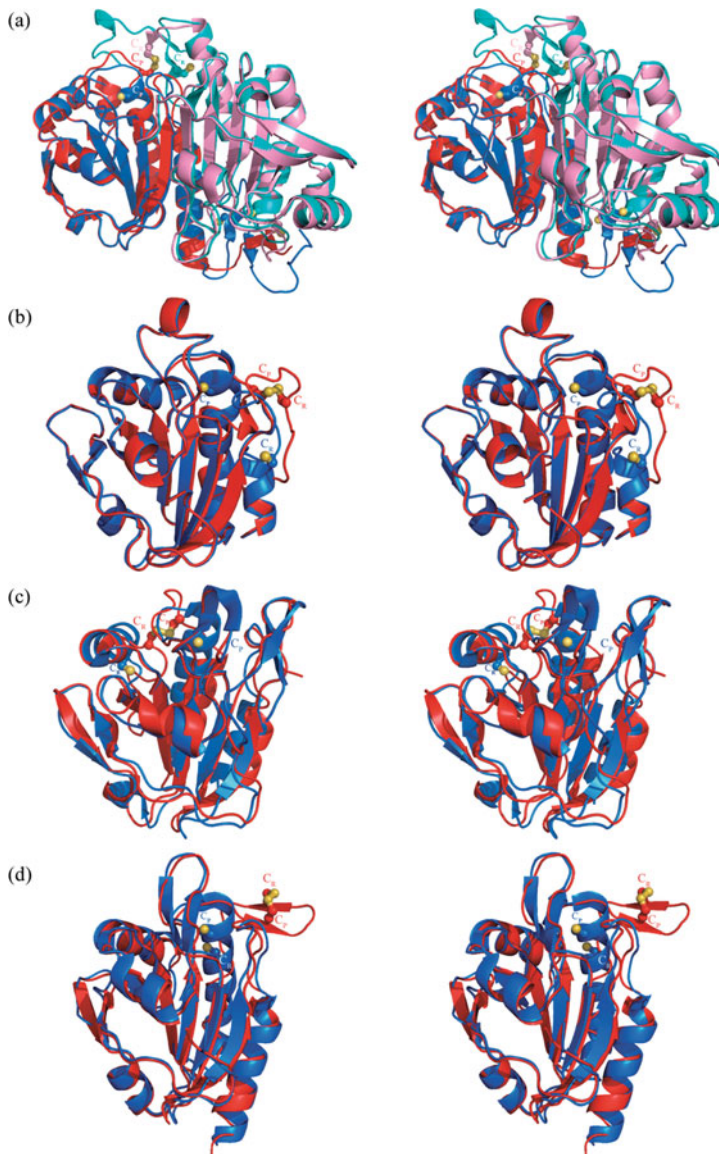

*Figure 7.* The local-unfolding conformational changes involved in resolution. Stereoviews are shown overlaying a representative fully-folded (blue tones) and locally-unfolded (red tones) structure from each of four Prx subfamilies: (a) the Prx1 subfamily represented by the B-type dimeric building block of *S. typhimurium* AhpC, with each chain of the dimer colored a distinct shade; (b) the Prx5 subfamily represented by human PrxV with an inferred locally-unfolded structure (see text); (c) the Tpx subfamily represented by *M. tuberculosis* and *H. influenzae* Tpx; (d) the BCP subfamily represented by *A. permix* BCP. The C<sub>p</sub> and C<sub>r</sub> residues are shown as ball-and-stick models in each structure with S<sub>p</sub> and S<sub>r</sub> colored mustard yellow (See Plate 6)

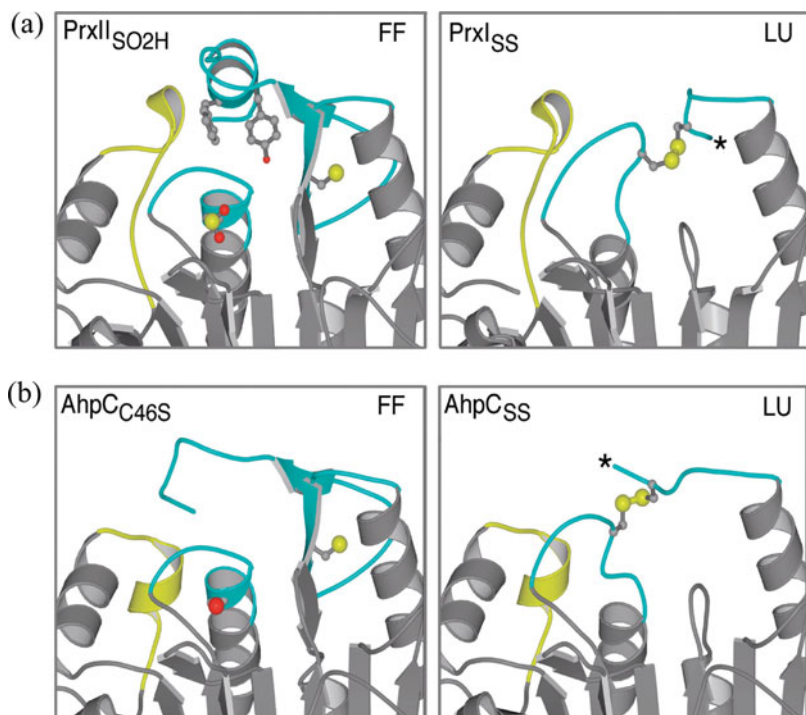

**Figure 8.** The structural difference between robust and sensitive typical 2-Cys Prxs. Views of (a) a sensitive Prx and (b) a robust Prx in the fully-folded forms (left panels) and in the locally-unfolded forms (right panels). In sensitive Prxs but not in robust Prxs, a C-terminal helix with a well conserved Tyr-Phe motif packs above the start of helix  $\alpha_2$ , and like a cork in a bottle stabilizes the fully-folded conformation, hindering its unfolding. This slows the resolution reaction and favors overoxidation by reaction with a second molecule of peroxide. In the locally-unfolded forms, an asterisk indicates the presence of additional disordered C-terminal residues. Figure reprinted from Wood *et al.* (2003a) *Science* **300**, 650–653 with permission (See Plate 7)

### 6.2.2. Subfamily Prx6

Subfamily Prx6 members studied thus far have a C-terminal extension that is even longer than the Prx1 enzymes, and include both 1-Cys and typical 2-Cys enzymes (Table 1). For the 1-Cys enzymes there is of course no resolving Cys required. The structurally known 2-Cys enzyme is representative of a group of archaeal Prxs having decameric structure and a C-terminally located C<sub>R</sub> that would appear to be mechanistically indistinguishable from the typical 2-Cys enzymes in the Prx1 subfamily. However, these enzymes are distinct in that the C<sub>R</sub> residue is positioned about 35 residues later in the sequence and is often present in close association with a third Cys in a CXDWWFC<sub>R</sub> motif (Mizohata *et al.*, 2005). The third Cys is not essential but may facilitate catalysis in certain circumstances. In the folded protein C<sub>R</sub> and C<sub>P</sub> are 13 Å apart and while no structure of a disulfide form is yet

known, as for Prx1 enzymes, disulfide formation must require some disordering of the C-terminal extension as well as local unfolding of the C<sub>p</sub> region.

### 6.2.3. Subfamily Prx5

The Prx5 subfamily also has both 1-Cys and 2-Cys (human Prx5) members, with 1-Cys members seemingly being more common (Copley *et al.*, 2004). For human PrxV, the C<sub>R</sub> residue is located in the turn between  $\beta$ 7 and  $\alpha$ 5 and is 14 Å away from C<sub>p</sub> (Figure 7b). No crystal structure is yet available for the catalytically relevant intramolecular disulfide form, but a structure for this form has been inferred from a fortuitous crystal structure of human Prx5 that includes an intermolecular disulfide between C<sub>p</sub> of one dimer with C<sub>R</sub> from another dimer (Evrard *et al.*, 2004). This structure reveals that disulfide formation involves unfolding of the first half of helix  $\alpha$ 5 as well as the unfolding of the C<sub>p</sub>-loop (Figure 7b).

### 6.2.4. Subfamily Tpx

The Tpx subfamily members all are atypical 2-Cys Prxs with the C<sub>R</sub> residue coming from within the C-terminal portion of helix  $\alpha$ 3 (Figure 3). The first structure solved in this family was for the disulfide form of *E. coli* Tpx (Choi *et al.*, 2003), and in this protein helix  $\alpha$ 3 (called  $\alpha$ 2 in that paper) was much shorter, and C<sub>R</sub> was located in the middle of a fairly long and mobile loop. The authors proposed, based on comparisons with fully-folded Prx structures, that in the dithiol form of Tpx the C<sub>R</sub>-containing chain segment would become helical and C<sub>p</sub> and C<sub>R</sub> would be separated by ~13 Å (Choi *et al.*, 2003). The unpublished structures now available for two fully-folded Tpxs (see Table 1) confirms those predictions (Figure 7c), revealing that resolution for this family requires the local unfolding of parts of both  $\alpha$ 2 and  $\alpha$ 3. During this structural change, a well-conserved aromatic residue just preceding C<sub>R</sub> tucks into the protein core vacated by the first turn of  $\alpha$ 2 when it unfolds.

### 6.2.5. Subfamily BCP

The structurally known BCP subfamily members are all atypical 2-Cys Prxs with the C<sub>R</sub> residue located just five residues beyond C<sub>p</sub> (Figure 3). Apparently some BCP members are 1-Cys Prxs, as they do not have this Cys residue present (See Table 3.2 of Copley *et al.*, 2004). Interestingly, in an unpublished structure of *A. permix* BCP, a 2-Cys Prx having two dimers in the asymmetric unit has one chain from each dimer in the fully-folded conformation and one chain in the disulfide bonded locally-unfolded conformation. Based on this structure, in the fully-folded enzyme C<sub>p</sub> and C<sub>R</sub> are 12 Å apart on successive turns of the  $\alpha$ 2 helix, and resolution involves complete unraveling of the  $\alpha$ 2 helix and the formation of a short beta-hairpin with the strands bridged by the disulfide (Figure 7d). Whether the redox asymmetry observed in the crystal reflects an asymmetry in solution chemistry of the dimer is not known.

## 7. OUTLOOK

In terms of structural understanding, the eight years of work since the first Prx structure was solved have seen much exciting progress, so that a firm foundation of knowledge exists that will support biochemical and biomedical research of all types of Prxs. The major remaining hole in structural knowledge of Prxs comes from the complete lack of structures of wild-type and mutant enzymes in complex with known substrates, products, or inhibitors. This is an exciting area for future research that will expand our currently rather limited understanding of detailed structural aspects of substrate recognition and enzyme mechanism.

## ACKNOWLEDGEMENTS

The authors thank Leslie Poole for editorial suggestions, and Kara Miles-Rockenfield for help with the preparation of figures. The authors' joint research program with Leslie Poole on peroxiredoxins is supported by National Institutes of Health grant RO1 GM050389.

## REFERENCES

- Alpey, M.S., Bond, C.S., Tetaud, E., Fairlamb, A.H., Hunter, W.N., 2000, The structure of reduced tryparedoxin peroxidase reveals a decamer and insight into reactivity of 2-Cys-peroxiredoxins. *J. Mol. Biol.* **300**: 903–916.
- Berman, H.M., Westbrook, J., Feng, Z., Gilliland, G., Bhat, T.N., Weissig, H., Shindyalov, I.N., Bourne, P. E., 2000, The Protein Data Bank. *Nucleic Acids Res.* **28**: 235–242.
- Biteau, B., Labarre, J., Toledano, M.B., 2003, ATP-dependent reduction of cysteine-sulphinic acid by *S. cerevisiae* sulphiredoxin. *Nature* **425**: 980–984.
- Bouillac, S., Rouhier, N., Tsan, P., Jacquot, J.P., Lancelin, J.M., 2004, (1)H, (13)C and (15)N NMR assignment of the homodimeric poplar phloem type II peroxiredoxin. *J. Biomol. NMR* **30**: 105–106.
- Bruns, C.M., Hubatsch, I., Ridderstrom, M., Mannervik, B., Tainer, J.A., 1999, Human glutathione transferase A4-4 crystal structures and mutagenesis reveal the basis of high catalytic efficiency with toxic lipid peroxidation products. *J. Mol. Biol.* **288**: 427–439.
- Cao, Z., Roszak, A.W., Gourlay, L. J., Lindsay, J.G., Isaacs, N.W., 2005, Bovine mitochondrial peroxiredoxin III forms a two-ring catenane. *Structure (Camb.)* **13**: 1661–1664.
- Chae, H.Z., Robison, K., Poole, L.B., Church, G., Storz, G., Rhee, S.G., 1994, Cloning and sequencing of thiol-specific antioxidant from mammalian brain: alkyl hydroperoxide reductase and thiol-specific antioxidant define a large family of antioxidant enzymes. *Proc Natl. Acad. Sci. USA* **91**: 7017–7021.
- Chang, T.S., Jeong, W., Woo, H.A., Lee, S.M., Park, S., Rhee, S.G., 2004, Characterization of mammalian sulfiredoxin and its reactivation of hyperoxidized peroxiredoxin through reduction of cysteine sulfinic acid in the active site to cysteine. *J. Biol. Chem.* **279**: 50994–51001.
- Chauhan, R., Mande, S.C., 2001, Characterization of the Mycobacterium tuberculosis H37Rv alkyl hydroperoxidase AhpC points to the importance of ionic interactions in oligomerization and activity. *Biochem. J.* **354**: 209–215.
- Choi, H.J., Kang, S.W., Yang, C.H., Rhee, S.G., Ryu, S.E., 1998, Crystal structure of a novel human peroxidase enzyme at 2.0 Å resolution. *Nat. Struct. Biol.* **5**: 400–406.
- Choi, J., Choi, S., Cha, M.K., Kim, I.H., Shin, W., 2003, Crystal structure of Escherichia coli thiol peroxidase in the oxidized state: insights into intramolecular disulfide formation and substrate binding in atypical 2-Cys peroxiredoxins. *J. Biol. Chem.* **278**: 49478–49486.



- Choi, J., Choi, S., Chon, J.K., Cha, M.K., Kim, I.H., Shin, W., 2005, Crystal structure of the C107S/C112S mutant of yeast nuclear 2-Cys peroxiredoxin. *Proteins* **61**: 1146–1149.
- Chothia, C., Lesk, A.M., 1986, The relation between the divergence of sequence and structure in proteins. *EMBO J.* **5**: 823–826.
- Copley, S.D., Novak, W.R., Babbitt, P.C., 2004, Divergence of function in the thioredoxin fold suprafamily: evidence for evolution of peroxiredoxins from a thioredoxin-like ancestor. *Biochemistry* **43**: 13981–13995.
- Declercq, J.-P., Evrard, C., Clippe, A., van der Stricht, D., Knoops, B., 2001, Crystal structure of human peroxiredoxin 5, a novel type of mammalian peroxiredoxin at 1.5 Å resolution. *J. Mol. Biol.* **311**: 751–759.
- Echalier, A., Trivelli, X., Corbier, C., Rouhier, N., Walker, O., Tsan, P., Jacquot, J.P., Aubry, A., Krimm, I., and Lancelin, J.M., 2005, Crystal structure and solution NMR dynamics of a D (type II) peroxiredoxin glutaredoxin and thioredoxin dependent: a new insight into the peroxiredoxin oligomerism. *Biochemistry* **44**: 1755–1767.
- Evrard, C., Capron, A., Marchand, C., Clippe, A., Wattiez, R., Soumillion, P., Knoops B., and Declercq, J.P., 2004, Crystal structure of a dimeric oxidized form of human peroxiredoxin 5. *J. Mol. Biol.* **337**: 1079–1090.
- Guimaraes, B.G., Souchon, H., Honore, N., Saint-Joanis, B., Brosch, R., Shepard, W., Cole, S.T., and Alzari, P.M., 2005, Structure and mechanism of the alkyl hydroperoxidase AhpC, a key element of the Mycobacterium tuberculosis defense system against oxidative stress. *J Biol. Chem.* **280**: 25735–25742.
- Hirotsu, S., Abe, Y., Okada, K., Nagahara, N., Hori, H., Nishino T., and Hakoshima, T., 1999, Crystal structure of a multifunctional 2-Cys peroxiredoxin heme-binding protein 23 kDa/proliferation-associated gene product. *Proc. Natl. Acad. Sci. USA* **96**: 12333–12338.
- Immenschuh, S., and Baumgart-Vogt, E., 2005, Peroxiredoxins, oxidative stress, and cell proliferation. *Antioxid. Redox Signal.* **7**: 768–777.
- Kang, S.W., Rhee, S.G., Chang, T.S., Jeong W., and Choi, M.H., 2005, 2-Cys peroxiredoxin function in intracellular signal transduction: therapeutic implications. *Trends Mol. Med.* **11**: 571–578.
- Kim, S.J., Woo, J.R., Hwang, Y.S., Jeong, D.G., Shin, D.H., Kim K., and Ryu, S.E., 2003, The tetrameric structure of Haemophilus influenzae hybrid Prx5 reveals interactions between electron donor and acceptor proteins. *J. Biol. Chem.* **278**: 10790–10798.
- Kitano, K., Niimura, Y., Nishiyama Y., and Miki, K., 1999, Stimulation of peroxidase activity by decamerization related to ionic strength: AhpC protein from Amphibacillus xylanus. *J. Biochem. (Tokyo)* **126**: 313–319.
- Kristensen, P., Rasmussen D.E., and Kristensen, B.I., 1999, Properties of thiol-specific anti-oxidant protein or calpromotin in solution. *Biochem. Biophys. Res. Commun.* **262**: 127–131.
- Li, S., Peterson, N.A., Kim, M.Y., Kim, C.Y., Hung, L.W., Yu, M., Legin, T., Segelke, B.W., Lott J.S., and Baker, E.N., 2005, Crystal Structure of AhpE from Mycobacterium tuberculosis, a 1-Cys peroxiredoxin. *J. Mol. Biol.* **346**: 1035–1046.
- Mizohata, E., Sakai, H., Fusatomi, E., Terada, T., Murayama, K., Shirouzu M., and Yokoyama, S., 2005, Crystal structure of an archaeal peroxiredoxin from the aerobic hyperthermophilic crenarchaeon *Aeropyrum pernix* K1. *J. Mol. Biol.* **354**: 317–329.
- Nakamura, T., Yamamoto, T., Inoue, T., Matsumura, H., Kobayashi, A., Hagihara, Y., Uegaki, K., Ataka, M., Kai Y., and Ishikawa, K., 2006, Crystal structure of thioredoxin peroxidase from aerobic hyperthermophilic archaeon *Aeropyrum pernix* K1. *Proteins* **62**: 822–826.
- Papinutto, E., Windle, H.J., Cendron, L., Battistutta, R., Kelleher D., and Zanotti, G., 2005, Crystal structure of alkyl hydroperoxide-reductase (AhpC) from *Helicobacter pylori*. *Biochim. Biophys. Acta* **1753**: 240–246.
- Parsonage, D., D. S. Youngblood, G. N. Sarma, Z. A. Wood, P. A. Karplus and L. B. Poole, 2005, Analysis of the link between enzymatic activity and oligomeric state in AhpC, a bacterial peroxiredoxin. *Biochemistry* **44**: 10583–10592.
- Pineyro, M.D., Pizarro, J.C., Lema, F., Pritsch, O., Cayota, A., Bentley G.A., and Robello, C., 2005, Crystal structure of the tryparedoxin peroxidase from the human parasite *Trypanosoma cruzi*. *J. Struct. Biol.* **150**: 11–22.

- Sarma, G.N., Nickel, C., Rahlfs, S., Fischer, M., Becker K., and Karplus, P.A., 2005, Crystal structure of a novel *Plasmodium falciparum* 1-Cys peroxiredoxin. *J. Mol. Biol.* **346**: 1021–1034.
- Sayed, A.A., and Williams, D.L., 2004, Biochemical characterization of 2-Cys peroxiredoxins from *Schistosoma mansoni*. *J. Biol. Chem.* **279**: 26159–26166.
- Schröder, E., Littlechild, J.A., Lebedev, A.A., Errington, N., Vagin A.A., and Isupov, M.N., 2000, Crystal structure of decameric 2-Cys peroxiredoxin from human erythrocytes at 1.7 Å resolution. *Structure Fold. Des.* **8**: 605–615.
- Schröder, E., Willis A.C., and Ponting, C.P., 1998, Porcine natural-killer-enhancing factor-B: oligomerization and identification as a calpain substrate in vitro. *Biochim. Biophys. Acta* **1383**: 279–291.
- Stehr, M., Hecht, H.-J., Jäger, T., Flohé, L., and Singh, M., 2006, Structure of the inactive variant C60S of *Mycobacterium tuberculosis* thiol peroxidase. *Acta Crystallogr. D. Biol. Crystallogr.* **62**: 563–567.
- Trivelli, X., Krimm, I., Ebel, C., Verdoucq, L., Prouzet-Mauleon, V., Chartier, Y., Tsan, P., Lauquin, G., Meyer Y., and Lancelin, J.M., 2003, Characterization of the yeast peroxiredoxin Ahp1 in its reduced active and overoxidized inactive forms using NMR. *Biochemistry* **42**: 14139–14149.
- Woo, H.A., Chae, H.Z., Hwang, S.C., Yang, K.S., Kang, S.W., Kim K., and Rhee, S.G., 2003, Reversing the inactivation of peroxiredoxins caused by cysteine sulfinic acid formation. *Science* **300**: 653–656.
- Wood, Z. A., Poole, L.B., Hantgan R.R., and Karplus, P.A., 2002, Dimers to doughnuts: redox-sensitive oligomerization of 2-cysteine peroxiredoxins. *Biochemistry* **41**: 5493–5504.
- Wood, Z.A., Poole L.B., and Karplus, P.A., 2003a, Peroxiredoxin evolution and the regulation of hydrogen peroxide signaling. *Science* **300**: 650–653.
- Wood, Z.A., Schröder, E., Harris J.R., and Poole, L.B., 2003b, Structure, mechanism and regulation of peroxiredoxins. *Trends Biochem. Sci.* **28**: 32–40.

## CHAPTER 4

# THE CATALYTIC MECHANISM OF PEROXIREDOXINS

LESLIE B. POOLE

*Department of Biochemistry, Center for Structural Biology, BGTC, Wake Forest University School of Medicine, Winston-Salem, NC 27157, USA*

**Abstract:** Peroxiredoxins carry out the efficient reduction of a typically broad range of peroxide substrates through an absolutely conserved, activated cysteine residue within a highly conserved active site pocket structure. Though details of reductive recycling after cysteine sulfenic acid formation at the active site vary among members of different Prx classes, local unfolding around the active site cysteine is likely generally required in these proteins for disulfide bond formation with a second resolving cysteine and/or for access of the reductant to the oxidized active site. The conformational change associated with the catalytic cycle and the redox-dependent decamer formation occurring in at least some typical 2-Cys Prxs have interesting implications in the interplay between active site loop dynamics, oligomerization state, catalytic efficiency and propensity toward inactivation during turnover in these important antioxidant enzymes

**Keywords:** Cysteine thiol, Sulfenic acid, Conformational change, Oligomerization, Oxidative inactivation

## 1. INTRODUCTION

Unlike the other major peroxide detoxification systems, namely catalases and peroxidases (which contain tightly or covalently bound heme) and true glutathione peroxidases (which have a selenocysteine at the active site), peroxiredoxins (Prxs; EC 1.11.1.15) rely on the cysteine sulfur at the active site as the catalytic center attacking the peroxy  $-O-O-$  bond. Nonetheless, activation of this cysteine and the surrounding residues that support this function are sufficient, in at least some of the Prxs, to impart a level of catalytic efficiency that is on a par with those of the above enzymes ( $> 10^7 \text{ M}^{-1} \text{ s}^{-1}$ ) (Budde *et al.*, 2003; Akerman and Müller, 2005; Parsonage *et al.*, 2005). Initial studies of the biochemical functions of members of this family of antioxidant proteins focused on roles in protection of bacterial DNA from oxidant damage (Christman *et al.*, 1985; Greenberg and Demple, 1988; Jacobson *et al.*, 1989) and in protection of yeast glutamine synthetase from oxidative inactivation (Kim *et al.*, 1988). As the recognition and understanding of

this family grew (Chae *et al.*, 1994), it became clear that, in addition to or as a part of the various cellular functions that were ascribed to these proteins, the Prxs have in common their ability to enzymatically reduce peroxides, including (for broad specificity Prxs, which seems to include most) hydrogen peroxide, organic hydroperoxides and peroxyxynitrite (Hofmann *et al.*, 2002; Wood *et al.*, 2003b). In *Escherichia coli*, the major Prx in the cytosol, AhpC, is the primary reducing system for endogenously-generated hydrogen peroxide, with catalase becoming the primary scavenger only at relatively high levels of peroxides ( $> 5 \mu\text{M}$ ), because the capacity to regenerate reduced AhpC becomes limiting (Seaver and Imlay, 2001). The increasing availability of structural and kinetic information for the widespread and in some ways diverse group of Prx proteins has given us insight into many aspects of the structure-function relationships within them. As described in further detail in this chapter, a coalition of structural, dynamic and chemical features are all intimately involved in imparting to Prxs their modulated catalytic and cellular functions.

## 2. CATALYSIS OF THE PEROXIDE REDUCTION STEP

### 2.1. Reaction at the Critical Cysteine Residue

With one notable exception of a selenocysteine-containing Prx (Söhling *et al.*, 2001), the only redox center in Prxs, completely conserved among all members, is the Cys residue at the active site (Cys51 in PrxII numbering), termed the peroxidatic Cys ( $C_p$  or  $S_p$  symbols used for the peroxidatic Cys or sulfur atom, respectively, Fig. 1). Accordingly, any mutations of this residue completely abrogate activity (Chae *et al.*, 1994; Ellis and Poole, 1997; Montemartini *et al.*, 1999; Chen *et al.*, 2000; Flohé *et al.*, 2002; König *et al.*, 2003; Deponite and Becker, 2005). A second Cys residue, designated as the resolving Cys ( $C_R$  or  $S_R$ ) can and often does participate in catalysis in later steps (see below and Fig. 2), but this residue is both unnecessary and peripheral (in a structural and chemical sense) to the peroxidatic active site and mechanism. Interestingly, although the Prxs have diverged into separate classes based on their sequences, oligomerization properties and recycling mechanisms, they exhibit very highly conserved structures and sequences around the active site. The peroxidatic Cys is located within the first turn of an  $\alpha$ -helix following a flexible loop region, in a location that parallels that of the second Cys of the CxxC motif in thioredoxin (Trx); Trx is a distant homologue which defines the core structural fold of Prxs and is prototypical of a superfamily of redox enzymes built on related motifs (T/S/CxxC and CxxT/S/C) (Fomenko and Gladyshev, 2003; Wood *et al.*, 2003b; Copley *et al.*, 2004). In Prxs, this Cys residue sits at the base of the active site pocket and is activated for catalysis by interactions with several conserved residues surrounding it (see below), in part acting to lower the  $pK_a$  of this group for nucleophilic attack on the terminal oxygen of the hydroperoxide (ROOH) substrate (Fig. 3). The need for deprotonation as well as additional activation by other features of the active site microenvironment is clear, given that protonated

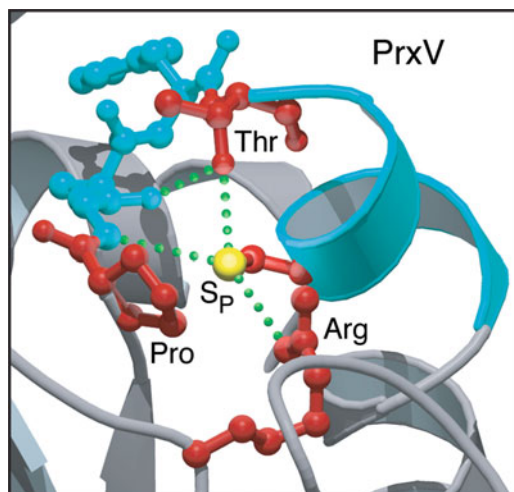

*Figure 1.* Conserved structure of Prx active sites. Shown in red are the conserved Pro, Thr, and Cys in the PxxTxxC active site motif, as well as the conserved Arg residue contributed by another part of the polypeptide (from human PrxV, PDB code 1hd2). Dotted lines indicate the conserved hydrogen bonding network. Blue indicates the loop-helix region around the active site that undergoes local unfolding following oxidation to form a disulfide bond in typical and atypical 2-Cys Prxs. This figure was reprinted from *Trends in Biochemical Sciences*, Vol. 28, article by Wood, Z.A., Schröder, E., Harris, J.R., and Poole, L.B., Structure, mechanism and regulation of peroxiredoxins, pages 32–40, Copyright 2003, with permission from Elsevier (See Plate 8)

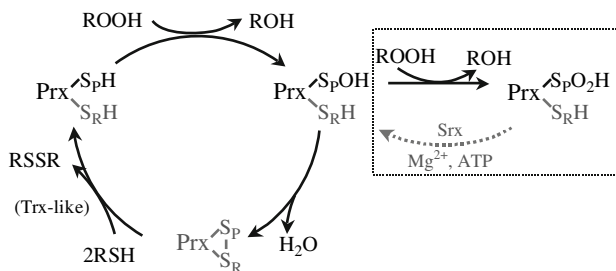

*Figure 2.* Catalytic and overoxidation cycles of Prxs. The peroxidatic Cys of the Prx is depicted as a thiol ( $S_pH$ ) or sulfenic acid ( $S_pOH$ ), or in a disulfide with the resolving Cys ( $S_RH$ ). In 2-Cys Prxs both Cys residues are involved in the mechanism (black and grey), whereas catalysis in 1-Cys Prxs involves only the black species. The box to the right illustrates the inactivation shunt which can occur in the presence of excess substrate. In select Prxs, this overoxidation can be reversed by specialized sulfiredoxin (Srx) or sestrin proteins (grey, dotted line). The disulfide reductase system (lower left) that returns oxidized Prxs to their activated state varies with the organism and isoform, often being a thioredoxin (Trx) or glutaredoxin homologue and/or flavoenzyme (e.g. AhpF or thioredoxin reductase), and generally utilizing at least one, and usually more, CxxC-containing proteins or domains

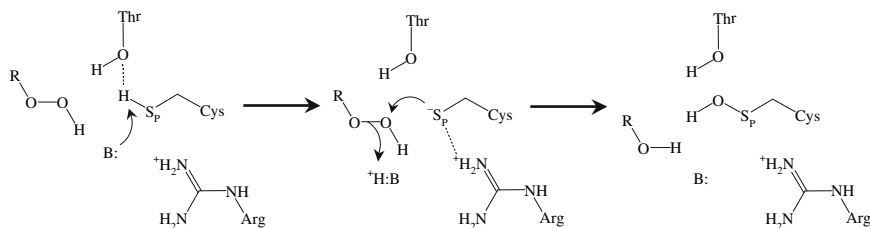

*Figure 3.* The common first step of peroxide reduction in Prxs. Peroxide reduction is initiated by nucleophilic attack by the thiolate form of the peroxidatic cysteine; this generates the sulfenic acid form of the active site cysteine and the alcohol (or first water) product. Both the catalytic base that deprotonates the peroxidatic cysteine and the catalytic acid that protonates the RO<sup>-</sup> leaving group are labelled “B”, although this does not imply that they are necessarily the same entity. The positively-charged guanidino group of the conserved arginine and the proximal threonine are presumed to stabilize the thiolate anion at the active site

thiol groups (R-SH) are essentially unreactive with peroxides in the absence of metals, and model thiolate anions (R-S<sup>-</sup>) exhibit rates of reaction toward peroxides in a range of about 18 to 26 M<sup>-1</sup>s<sup>-1</sup> at 37 °C (Torchinaky, 1981; Winterbourn and Metodiewa, 1999).

## 2.2. Other Active Site Residues Participating in Catalysis

Ideally, the reaction of the cysteine with peroxide, as shown in Fig. 3, would involve a base to remove the proton from the peroxidatic Cys and/or an acid to protonate the RO<sup>-</sup> leaving group, but it is still not clear which residue(s) may be responsible for such role(s) in these enzymes (and either or both roles could be played by water). One candidate present in a subset of 1-Cys Prxs is a His side chain (His39 in human PrxVI and *Toxoplasma gondii* Prx2), but this could only be a player in the restricted set of Prxs that have it (Choi *et al.*, 1998; Deponete and Becker, 2005) and may instead have a primary role in Cys-SOH (or Cys-SO<sup>-</sup>) stabilization. Two of the most highly conserved residues in the vicinity of the active site Cys, Thr48 and Arg127, appear to act in concert with the peroxidatic Cys (Cys51 in PrxII numbering) to carry out catalysis in all Prxs, as described in more detail below. Stabilization of the cysteine sulfenic acid (S-hydroxycysteine, abbreviated Cys-SOH here) that remains on the enzyme after attack on the peroxide may also be a factor whereby similar mechanisms, including hydrogen bonding with the thiol(ate) and/or lowering of the cysteinyl pK<sub>a</sub> before reaction, are again involved in stabilization of this oxidized enzyme species.

As shown in Figs. 1 and 3, Thr48 of the “TxxC” motif with C<sub>p</sub> is clearly important to catalysis, being within reasonable hydrogen bonding distance from the S<sub>γ</sub> of the peroxidatic Cys in structures with a “fully folded” active site loop-helix region (Wood *et al.*, 2003b). As expected, it is the hydroxyl group of the Thr side chain that is important, as Ser replacing this residue in an engineered mutant (and as a natural substitution in a few Prxs) seems to preserve activity, whereas substitution

of the corresponding Thr by Val does not yield active enzyme in the Prx studied from *Leishmania donovani* (Flohé *et al.*, 2002). Potential mechanistic roles for this conserved Thr include enhancement of the nucleophilicity of the peroxidatic Cys residue and maintenance of the proper orientation of this side chain for peroxide reactivity (Wood *et al.*, 2003b). For the conserved Arg residue (Arg127 in PrxII), the putative  $pK_a$  lowering effect is probably largely due to the electrostatic influence of the positively charged guanidino group contributed by this side chain that is distant in sequence, but near the active site in three-dimensional structure (Figs. 1 and 3). Mutagenesis of this residue in studies of a *Crithidia fasciculata* Prx enzyme (R128E) yielded inactive enzyme, although the drastic nature of the charge replacement and the tendency of this mutant to denature were complicating aspects of this analysis (Montemartini *et al.*, 1999). In *L. donovani* Prx, a similar substitution (R128D) also yielded inactive enzyme, although denaturation was not observed in this case (Flohé *et al.*, 2002). In the barley Prx (the Bas1 protein that localizes to chloroplasts) in which this Arg was replaced with a much more conservative Gln (R140Q), the enzyme was inhibited by about 50% in a thioredoxin-dependent assay, more when dithiothreitol (DTT) was used as the reductant in the assay (König *et al.*, 2003). Notably, this Arg side chain varies in orientation and location with respect to the  $C_p$  residue in the different crystal structures, with its strongest (bidentate salt bridge) interaction with Cys51 seen in the hyperoxidized, sulfinic acid form of PrxII from human erythrocytes (Schröder *et al.*, 2000). Interestingly, this conserved Arg residue replaces a conserved *cis*-Pro residue found in thioredoxins (Trxs) and cytochrome maturation proteins (CMPs), two distantly homologous protein families (see below) where this residue helps to form the binding platform for polypeptide substrates (Copley *et al.*, 2004). As pointed out by Copley, Novak and Babbitt (2004), with peroxides as substrates rather than polypeptides, the *cis*-Pro in this position in Trxs and CMPs is no longer needed by Prxs. It might be noted, however, that Prxs do interact with other redox proteins as part of their regeneration after peroxide reduction; for this part of the catalytic cycle, however, it appears that the structural context of the peroxidatic Cys is quite distinct from that of the “fully folded” active site (see below).

One additional residue, highlighted in Fig. 1, is also absolutely conserved in Prxs in proximity of the active site; based on structural observations, Pro44, within the conserved PxxxTxxC motif, limits solvent and peroxide accessibility of the peroxidatic Cys and helps shield the reactive Cys-SOH intermediate from oxidative inactivation by excess peroxide (Wood *et al.*, 2003b). In comparisons with related Trx and CMP proteins, this Pro residue replaces a Trp that is conserved in CMPs but only partially conserved in Trxs (Copley *et al.*, 2004).

### 2.3. Substrate Specificity Studies

Regarding specificity for peroxide substrates, it is clear that Prxs as a family exhibit activity toward a broad spectrum of hydroperoxides; most will reduce small hydroperoxides such as hydrogen peroxide and ethyl hydroperoxides, as well as

bulkier and more hydrophobic hydroperoxides such as t-butyl hydroperoxide and cumene hydroperoxide (Hofmann *et al.*, 2002; Dietz, 2003). In addition, fatty acid hydroperoxides and phospholipid-associated hydroperoxides are also accepted to a significant degree as substrates for a number of Prxs. Most studies do not provide highly quantitative information about substrate specificity, however, as various substrates are compared only as a set under given conditions, rather than as variable substrates in detailed analyses of bisubstrate kinetics. Such studies can give an overall impression of specificity if some substrates are very poor, but may miss large differences in  $K_m$  or  $k_{cat}$  values using just single concentrations of hydroperoxide substrates and/or assay conditions wherein reduction is rate limiting. Another approach to assessing substrate specificity, e.g. used in yeast and bacterial studies, is by looking for a growth defect after peroxide treatment upon targeted knockout of the Prx protein of interest (Lee *et al.*, 1999; Park *et al.*, 2000; Seaver and Imlay, 2001; Comtois *et al.*, 2003; Cha *et al.*, 2004). Such studies can be somewhat informative regarding physiological roles of various Prx family members, but are not direct readouts of specificity in enzymological terms.

Where specific  $k_{cat}$  and  $K_m$  values have been measured, the theme of broad specificity is maintained among a wide range of Prxs, where  $k_{cat}/K_m$  values for catalytic efficiency with the smallest hydrogen peroxide substrate through the larger t-butyl hydroperoxide and cumene hydroperoxide substrates differ by less than 10-fold (Choi *et al.*, 1999; Jeong *et al.*, 2000; Pedrajas *et al.*, 2000; König *et al.*, 2002; Rouhier *et al.*, 2004; Sayed and Williams, 2004). Several exceptions to this generally broad specificity have also been shown. For example, for *E. coli* thiol peroxidase (Tpx, also known as p20), cumene hydroperoxide was a much better substrate ( $k_{cat}/K_m = 7.7 \times 10^6 \text{ M}^{-1} \text{ s}^{-1}$ ) than was hydrogen peroxide ( $k_{cat}/K_m \approx 4 \times 10^4 \text{ M}^{-1} \text{ s}^{-1}$ ), with the  $K_m$  for the latter substrate above 1 mM (Baker and Poole, 2003). In a study of a 2-Cys Prx from the parasite *Toxoplasma gondii*, t-butyl hydroperoxide was reportedly a 32-fold better substrate than hydrogen peroxide based on  $k_{cat}/K_m$  values, although the very low (sub-micromolar)  $K_m$  values for both, far below the lowest substrate concentration used in the assays for t-butyl hydroperoxide, in particular, leave some doubt as to the quantitative validity of these findings (Akerman and Müller, 2005). For *S. typhimurium* AhpC, where quantitative assays to assess true  $K_m$  and  $k_{cat}$  values were only recently developed (Parsonage *et al.*, 2005),  $k_{cat}$  is approximately the same for all substrates tested, whereas the  $K_m$  values for organic hydroperoxides, at  $> 50 \mu\text{M}$ , are considerably higher than for hydrogen peroxide (1.4  $\mu\text{M}$ ) (Parsonage and Poole, unpublished results).

Lipid hydroperoxides, either as the fatty acids (e.g. linoleic acid hydroperoxide) or as fatty acyl chains within phospholipids (e.g. “phosphatidyl choline hydroperoxide,” probably representing phosphatidylcholine dilinoleoyl hydroperoxide), particularly as prepared using soybean lipoxygenase, have also been studied as substrates of Prxs (Hofmann *et al.*, 2002; Dietz, 2003). Again, highly quantitative evaluation of these species as substrates is generally lacking and is made more difficult by the low solubility of these hydrophobic substrates and their tendency to



form micelles in solution, as well as the common observation of substrate inactivation by these species (Cha *et al.*, 2000; Baker and Poole, 2003; Budde *et al.*, 2003a). Nonetheless, it is clear that Prxs may play an important role in reducing lipid hydroperoxides, formed during oxidative damage to cells or as lipoxygenase or cyclooxygenase products, and must be considered in the biological roles the Prxs play.

At least some, and perhaps all, Prxs are also able to act as peroxynitrite reductases and may well be the major players in reduction of this potent reactive species that results from superoxide and nitric oxide combination. Early work demonstrated the generation of sulfenic acid at the active site of bacterial AhpC proteins upon reaction with peroxynitrite (Bryk *et al.*, 2000). Subsequent studies of eukaryotic Prxs, as well, have demonstrated the extremely rapid rate of peroxynitrite-mediated oxidation of Prxs and their ability to act catalytically in reduction of these species (Dubuisson *et al.*, 2004; Trujillo *et al.*, 2004).

An interesting case of possible modulation of substrate specificity was discovered in *E. coli* AhpC, where a mutation that enhanced the ability of these bacteria to grow in an organic solvent, tetralin (1,2,3,4-tetrahydronaphthalene), was mapped to the *ahpC* gene and found to encode a G142V mutation (amino acid numbering including the N-terminal Met, which is removed from the mature protein) (Ferrante *et al.*, 1995). The resistance of these bacteria toward organic solvents extended to other agents such as cyclohexane, propylbenzene, and 1,2-dihydronaphthalene, as well. The working hypothesis for the effect of this mutation, with some evidence from assays of crude extracts of the wild type and mutant bacteria, was that the toxicity of the organic solvents is imparted to a significant degree by their hydroperoxides (e.g. tetralin hydroperoxide), and that the modified enzyme is more active with such substrates than is wild type AhpC. More studies are needed, however, to truly understand the link between this mutation, substrate specificity and protection of the bacteria from exposure to organic solvents.

### 3. RESIDUES CONSERVED AMONG SPECIFIC GROUPS OF PRXS WITH POSSIBLE ROLES IN CATALYSIS

Based on sequence and structure considerations, Prxs can be divided into four (or arguably five) groups, designated here by their prototypic members (Table 1) (Hofmann *et al.*, 2002; Dietz, 2003; Copley *et al.*, 2004; Rouhier and Jacquot, 2005; see also Chapter 2). Additional specific residues conserved among members of each of the groups may have roles in peroxidatic or reductive cycles of these Prxs and are therefore pointed out here, although such roles remain only speculative at this point.

The most widespread group of Prxs, found across all kingdoms, is the group that includes the “typical 2-Cys” Prxs related to bacterial AhpC and mammalian Prxs I through IV, so named due to the absolute conservation of both peroxidatic and resolving Cys residues that participate in catalysis (with C<sub>R</sub> in the partner subunit of the dimer, within a C-terminal extension relative to the Trx

Table 1. Classification of Prxs based on sequence and structure

Prototype members	Catalytic mechanism <sup>1</sup>	Predominant oligomeric state and interface type <sup>2</sup>	Active site consensus sequence <sup>3</sup>
Bacterial AhpC Human Prxs I-IV Human Prx VI Plant chloroplast Basi	Typical 2-Cys or Classical 1-Cys	( $\alpha_2$ ) <sub>5</sub> Decamers (built from dimers using A-type interface) and Dimers (B-type)	<b>PADFTFVCPTEL</b>
<i>E. coli</i> BCP Plant PrxQ	Atypical 2-Cys or 1-Cys	Monomers	<b>PLAFTPVCTKEAC</b>
Human PrxV Plant type II Prxs	Atypical 2-Cys or 1-Cys <sup>4</sup>	Dimers (A-type) or Monomers	<b>PGAFTPTCSANHL</b>
<i>E. coli</i> Tpx	Atypical 2-Cys	Dimers (A-type)	<b>PSIDTGVCAAQ/ SVR</b>

<sup>1</sup> 1-Cys mechanism involves only the peroxidatic Cys of the Prx, whereas a 2-Cys mechanism also includes a step of disulfide bond formation with a second resolving Cys elsewhere in the protein, as either an intersubunit disulfide (typical 2-Cys) or an intrasubunit disulfide (atypical 2-Cys).

<sup>2</sup> Two possible interfaces between subunits exist in Prxs, as either the B-type (where the edges of the beta sheets abut and form an extended beta sheet across the dimer, only present in the first class), or the A-type (alternate, or face-to-edge) interface (Sarma *et al.*, 2005).

<sup>3</sup> Active site consensus sequences around the peroxidatic Cys were generated by the MEME algorithm as described by the authors (Copley *et al.*, 2004).

<sup>4</sup> At least one member of this class, yeast Ahp1p, generates an intermolecular disulfide bond like typical 2-Cys Prxs (Jeong *et al.*, 1999; Lee *et al.*, 1999; Verdoucq *et al.*, 1999).

fold that yields a domain-swapped dimer in these proteins) (Wood *et al.*, 2003b). Based on the dimer interface and the conservation of Glu54 (PrxII numbering) and other conserved motifs throughout the proteins, “classical” 1-Cys Prxs related to human PrxVI are included in this group according to the classification scheme proposed by Copley *et al.* (Copley *et al.*, 2004), although these members may reasonably be split out into their own separate group, e.g. based on a larger C-terminal extension and the conservation of a His residue not present in other members (see above). Glu54 interacts with the conserved Arg in some of the structures of these proteins, suggesting a potential auxiliary role for this residue in catalysis. Interestingly, a conserved Glu is also present in the same position in the relatively poorly characterized group of Prxs related to bacterioferritin comigratory protein (BCP) from *E. coli*. In the other two groups of Prxs, those represented by mammalian PrxV and by *E. coli* Tpx, the Glu is not conserved, but is instead replaced by a conserved His residue (next door) in the former group, or by Gln or Ser residues in the latter group. Whether or not these alternative residues have any role in catalysis has so far not been addressed experimentally.

## 4. STEPS IN CATALYSIS BEYOND CYSTEINE SULFENIC ACID FORMATION: REDUCTION AND OVEROXIDATION

### 4.1. Distinctions between 1-Cys and 2-Cys Peroxidatic Mechanisms

It was recognized at an early stage that, while the Cys at the active site of Prxs is completely conserved, the additional Cys located near the C-terminal end of most Prxs is not always present and therefore not essential for catalysis; simple division of Prxs into 1-Cys and 2-Cys enzymes was therefore adopted (Chae *et al.*, 1994). As mechanistic and structural issues became clearer and more Prx family members were identified, it was noted that some Prxs do, in fact, include a second resolving Cys in their mechanism that is contributed by a residue within the same monomer of these enzymes, conserved in two different places in the two classes of Prxs that have them (the PrxV and Tpx groups, Table 1). This suggested to us a new mechanistic distinction that could be added, where the widespread group of “typical 2-Cys” Prxs, for which an intersubunit disulfide bond is generated during the catalytic cycle, could be distinguished from a closely-related, but structurally distinct, mechanism where the catalytic disulfide was formed within the monomer, designated the “atypical 2-Cys” Prxs (Wood *et al.*, 2003b). It is clear that none of these designations is absolute; typical or atypical 2-Cys Prxs can often be converted into mechanistically-classified 1-Cys Prxs by mutating the resolving Cys (Ellis and Poole, 1997; Montemartini *et al.*, 1999; Rouhier *et al.*, 2002; Baker and Poole, 2003; König *et al.*, 2003; Rouhier *et al.*, 2004; Trujillo *et al.*, 2006), and may even skip the disulfide bond formation step of the catalytic cycle during rapid turnover. Furthermore, there appear to be ways to form intersubunit disulfide bonds during catalysis that are structurally distinct from the disulfide bond formed between S<sub>P</sub> and S<sub>R</sub> in the typical 2-Cys Prxs, as observed for the PrxV class Ahp1p protein of yeast (Jeong *et al.*, 1999; Lee *et al.*, 1999; Verdoucq *et al.*, 1999) and for the “classical 1-Cys Prx”-like TgPrx2 from *Toxoplasma gondii* (Deponete and Becker, 2005).

As is obvious from the evolving classification schemes of Prxs (Table 1 and Chapter 2), multiple mechanisms are represented in each of the classes, excluding, perhaps, the Tpx group so far. BCP proteins were originally considered 1-Cys Prxs (Jeong *et al.*, 2000) and in some cases don't even conserve the second Cys residue within the PxxxTxxCxxExC motif (Table 1), even though some biochemical and structural data supports disulfide bond formation between the two in oxidized BCP-related proteins (Kong *et al.*, 2000; Rouhier *et al.*, 2004) (pdb codes 2CX3 and 2CX4, BCP-like proteins from *Aeropyrum pernix*, unpublished). Another clear example of a 1-Cys mechanism within a class that is mostly represented by atypical 2-Cys Prxs is the PrxV-like AOP protein from *Plasmodium falciparum* (Sarma *et al.*, 2005). The designation of 1-Cys and 2-Cys mechanisms is therefore useful terminology in the field, and “typical 2-Cys” certainly designates a large class of rather well characterized Prxs, but these designations are meant to convey mechanistic information about catalytic cycles and are not the only considerations needed for more structure- and evolution-based classification schemes (Table 1 and Chapter 2).

## 4.2. Reductive Recycling of Prxs

As depicted in Fig. 2, following reaction with the peroxide substrate as described in section 2, Prxs must be “recycled” for catalysis through reduction of the active site sulfenic acid back to its thiol form; for 1-Cys Prx mechanisms the thiol groups participating in this recycling come from other proteins or small molecules, whereas typical and atypical 2-Cys Prxs first go on to form a disulfide bond between the peroxidatic and resolving Cys residues. Reductants of these proteins therefore encounter either sulfenic acid or disulfide-bonded forms of Prxs as their oxidizing substrates. In either case, the attacking thiol(ate) of the reductant first forms a mixed disulfide bond with the Prx, transiently linking the reductant and Prx through a covalent attachment, then the mixed disulfide is resolved by a second thiol group, typically the more C-terminal Cys of the CxxC center of thioredoxin- or glutaredoxin-like protein reductants. The re-reduced Prx released by this thiol-disulfide interchange step is then activated for another catalytic cycle.

So far there is no high resolution structure of a Prx bound to its reductant in a way that mimics their catalytic interaction, although the structure of an unusual glutaredoxin-peroxiredoxin “hybrid” protein from *Haemophilus influenzae* has offered some insight along these lines (Kim *et al.*, 2003). Biochemical models which may ultimately prove useful for crystallization purposes have been generated where disulfide bonds between the donor and acceptor proteins are formed using natural or chemical oxidation processes and stabilized by mutation of one of the two interacting Cys residues in one or both protein(s) (Poole, 1999; Budde *et al.*, 2003b; Rouhier *et al.*, 2004). In the typical 2-Cys Prxs, such studies, in addition to structural arguments which point out the buried nature of C<sub>P</sub> and the partial accessibility of C<sub>R</sub> in the disulfide-bonded structures, point to the resolving Cys as the site of nucleophilic attack by CxxC-containing protein reductants (Hirotsu *et al.*, 1999; Poole, 1999; Hofmann *et al.*, 2002; Budde *et al.*, 2003b; Rouhier *et al.*, 2004). Mobilization of the remaining C-terminal residues (following C<sub>R</sub>) in the oxidized structures of typical 2-Cys Prxs is likely an additional important factor in allowing access of the reductant to the oxidized redox center (Hirotsu *et al.*, 1999; Wood *et al.*, 2002). Elimination of the resolving Cys by mutation can, in at least some cases, still allow for the recycling of the Cys-S<sub>P</sub>OH with the reductant, although this reaction may be slowed considerably by the mutation of C<sub>R</sub> (Ellis and Poole, 1997; Montemartini *et al.*, 1999; Rouhier *et al.*, 2002; Baker and Poole, 2003; König *et al.*, 2003; Rouhier *et al.*, 2004; Trujillo *et al.*, 2006). In atypical 2-Cys Prxs, it is less clear which Cys residue is involved in the direct attack by CxxC-containing protein reductants.

As mentioned above and in Fig. 2, the nature of the reductant involved in recycling each Prx depends on the organism and specific family member. Many of the Prxs in all four classes are recycled by thioredoxin (Trx), a characteristic which has led to the use of one of the alternative names for Prxs, thioredoxin peroxidases (Rhee *et al.*, 2005). Bacterial AhpC proteins with amino acid identities greater than 55% compared with *E. coli* and *S. typhimurium* AhpC are expressed from loci that include a downstream gene encoding a specialized flavoprotein reductase, AhpF

(Poole *et al.*, 2000; Poole, 2003; Poole, 2005); in these NAD(P)H:Prx oxidoreductase proteins, a tandem repeat of two Trx-like folds in a single N-terminal electron-donating domain is fused to a Trx reductase homologue which shunts the electrons from reduced pyridine nucleotides to the N-terminal domain. Other specialized proteins have evolved in other systems as dedicated Prx reductases, as well. In the Kinetoplastida (including the insect pathogen, *Crithidia fasciculata*, and mammalian pathogenic species of *Trypanosoma* and *Leishmania*), Prxs are recycled by a Trx-like protein, tryparedoxin, that is itself reducible by the low molecular weight thiol specific to these organisms, trypanothione (see Chapter 9) (Nogoceke *et al.*, 1997; Hofmann *et al.*, 2002). Both glutaredoxins and thioredoxins can be reductants of a number of the plant Prxs (Dietz, 2003; Rouhier and Jacquot, 2005). As mentioned, glutaredoxin (Grx) has been identified as a fused reductase domain for the *H. influenzae* Grx-PrxV type of hybrid protein (Kim *et al.*, 2003), as well as a similarly chimeric protein from *Chromatium gracile* which has the unique property of using glutathione amide as its electron donor (Vergauwen *et al.*, 2001). A uniquely evolved Grx homologue, Cp9, encoded just upstream of the Prx gene, was also identified as the direct electron donor to a typical 2-Cys Prx, Cp20 in *Clostridium pasteurianum* (Reynolds *et al.*, 2002). An unusual redox protein with Trx-like activity but a very distinct structure, AhpD, was identified as a reductant of the AhpC-like protein in *Mycobacteria* species (Bryk *et al.*, 2002; Nunn *et al.*, 2002; Koshkin *et al.*, 2003), although new evidence suggests that several different mycobacterial Trx proteins can also serve as Prx reductants in these organisms (Jaeger *et al.*, 2004).

As described above, most Prx reductants are CxxC-containing redox proteins. The largely ubiquitous small molecule reductant, glutathione, is not commonly observed to be a reductant of Prxs, although there are several notable exceptions to this generality. Two 2-Cys Prxs from *Schistosoma mansoni* are efficiently reduced by both glutathione and Trx; interestingly, these organisms also express a flavoprotein reductase which can recycle oxidized forms of both reductants, as well (Sayed and Williams, 2004). Controversy surrounding the identity of the cellular reductant of the classical 1-Cys Prx, human PrxVI, has persisted for some time over whether or not glutathione could act as a reductant (Kang *et al.*, 1998; Fisher *et al.*, 1999; Peshenko and Shichi, 2001). This paradox may have recently been resolved by demonstration of the direct participation of glutathione-S-transferase  $\pi$  in the recycling of this enzyme by glutathione (Manevich *et al.*, 2004; Ralat *et al.*, 2006).

### 4.3. Oxidative Inactivation of Prxs during Turnover

If the sulfenic acid-containing Prxs generated upon reaction with one equivalent of peroxide substrate are not rapidly converted to disulfide-bonded proteins or recycled by reductases, a second equivalent of substrate can oxidize C<sub>p</sub> to its inactive sulfinic acid (R-SO<sub>2</sub>H) form through a similar nucleophilic attack by the sulfenic acid or sulfenate anion on the peroxy –O–O– bond (Fig. 2, upper right). The structure of the human PrxII from erythrocytes included this oxidized, sulfinic acid form of the active site (Schröder *et al.*, 2000), and it has since become quite clear that

this propensity toward “overoxidation” is a characteristic feature of at least some eukaryotic Prxs (Mitsumoto *et al.*, 2001; Rabilloud *et al.*, 2002; Yang *et al.*, 2002; Wood *et al.*, 2003a). A very recent structure of the PrxV-like AOP protein from *P. falciparum*, mentioned above, possessed a sulfonic acid (R-SO<sub>3</sub>H) at the active site; this structure thus nicely serves as a model for the catalytic overoxidation mechanism (Sarma *et al.*, 2005).

Comparisons between eukaryotic and prokaryotic Prx structures in different redox states and the sequences conserved in regions packing around the fully folded active site loop-helix were used to derive a structural explanation for this propensity toward overoxidation (Wood *et al.*, 2003a) (see also Chapter 3 and figures therein). As local unfolding around the active site loop-helix region must occur to allow for disulfide bond formation between C<sub>P</sub> and C<sub>R</sub> in all typical and atypical 2-Cys Prxs studied to date, any features that disfavor this local unfolding will impart a kinetic pause in disulfide bond formation that would augment partitioning toward overoxidation (Fig. 2). In eukaryotic typical 2-Cys Prxs, additional, evolved structural features which participate in packing interactions around C<sub>P</sub> are present, but not included in most prokaryotic Prxs, that would be likely to accentuate such a kinetic pause in disulfide bond formation; these structural features include conserved motifs in two regions, a “GGLG” motif inserted just after a 3<sub>10</sub> helix and a “YF” motif in the additional C-terminal helix present in these eukaryotic proteins (Wood *et al.*, 2003a). These evolved structural features can thus impede the normal catalytic cycle, but they also allow the sulfenic acid form of C<sub>P</sub> to act not only as a catalytic intermediate, but also as a redox switch for these enzymes. Although the exact biological function of this evolved redox switch is not completely clear, Wood, Poole and Karplus suggested that it may be needed, under some conditions, to allow for rapid, localized rises in cellular hydrogen peroxide concentrations above threshold levels to trigger redox-dependent cell signaling; this proposal encompasses the “floodgate hypothesis” for the function of the evolved sensitivity of eukaryotic Prxs toward peroxide-mediated inactivation (Wood *et al.*, 2003a). Alternative, but not mutually-exclusive, explanations have also been offered. Overoxidation of eukaryotic Prxs appears to promote aggregation beyond decameric complexes and to switch on a chaperone activity that may help protect cellular proteins under conditions of oxidative stress (Jang *et al.*, 2004; Moon *et al.*, 2005). A very recent transmission electron microscopy study has demonstrated formation of a dodecahedron (12 decamers, or 120 subunits) of human PrxII on a perforated/holey carbon support film that may bear some relationship to these previously observed high molecular weight species (Meissner *et al.*, 2006). Overoxidized Prxs may also act as signaling molecules themselves, for example by associating to a larger degree with membranes (as observed in erythrocytes and chloroplasts) and triggering biological responses (Cha *et al.*, 2000; Schröder *et al.*, 2000; König *et al.*, 2003). The fact that at least one group of enzymes, the sulfiredoxins (discussed in Chapter 6), and perhaps also the p53-regulated sestrins, have apparently evolved along with this propensity toward overoxidation to rescue overoxidized Prxs (Biteau *et al.*, 2003; Budanov *et al.*, 2004) certainly bolsters the suggestion that oxidant sensitivity evolved as a

gain-of-function for eukaryotic Prxs. Interestingly, another regulatory mechanism that might be of relevance for eukaryotic Prxs is proteolysis, where residues at the C-terminal end are removed; such a truncation would be expected to alter the sensitivity of these Prxs, changing “sensitive” proteins into their “robust” counterparts which would no longer respond to highly oxidizing conditions (Schröder *et al.*, 1998; Koo *et al.*, 2002; Wood *et al.*, 2003a; Wood *et al.*, 2003b).

## 5. INTERPLAY BETWEEN OLIGOMERIC STATE, CATALYSIS AND INACTIVATION DURING TURNOVER IN TYPICAL 2-CYS PRXS

The assembly of protein subunits into particular oligomeric structures is rarely a consideration in discussions of the catalytic mechanisms of enzymes unless an enzyme’s active site is formed at an oligomerization interface or multiple domains in different subunits of an enzyme must interact for catalysis; in addition, the oligomeric state of an enzyme is often a static feature, although a theme has been developing recently whereby oligomeric state changes in some enzymes can be regulatory (Breinig *et al.*, 2003). In catalyzing the peroxide reduction step, Prxs are apparently functionally monomeric; all residues comprising the fully folded, peroxidatic active site come from a single subunit. During the next step of the catalytic cycle, however, typical 2-Cys Prxs form intersubunit disulfide bonds with the C<sub>R</sub> contributed by a partner subunit, making dimers the minimal functional unit of activity in this group of enzymes. Interestingly, the  $\alpha_2$  dimers of typical 2-Cys and classical 1-Cys Prxs like human PrxVI are built using a different subunit interface than for dimers in the other Prx classes (see Chapter 3 for details); as pointed out in Table 1, the central  $\beta$ -sheets of the Trx-like core are arranged side-by-side in an antiparallel orientation (generating the B-type interface) to create the extended  $\beta$ -sheet within these  $\alpha_2$  dimers (Wood *et al.*, 2003b; Sarma *et al.*, 2005). In the other classes of Prxs, dimers employ a different “tip-to-tip” type of interface designated as the A-type, or alternate, interface (Copley *et al.*, 2004; Sarma *et al.*, 2005). An intriguing property of at least some typical 2-Cys Prxs is their propensity to form toroid-shaped decamers (Alphey *et al.*, 2000; Schröder *et al.*, 2000; Wood *et al.*, 2002). These decamers are built from dimers using this same A-type interface present in dimeric members of the PrxV and Tpx groups (Table 1).

Formation of decamers from dimers, as well as the generation of apparently higher molecular weight aggregates of these proteins, is highly dependent on solution conditions and protein redox or modification status. Early investigations focused on PrxII from human or porcine erythrocytes indicated that high molecular weight species were observed in acidic pH or high calcium concentration conditions, though the exact nature of these high molecular weight species was not clear and any linkage of molecular weight to redox state was not reported (Plishker *et al.*, 1992; Kristensen *et al.*, 1999). Other work with PrxII (Schröder *et al.*, 1998; Schröder *et al.*, 2000), *S. typhimurium* AhpC (Wood *et al.*, 2002) and *C. pasteurianum* Cp20

(Reynolds *et al.*, 2002) has implicated redox state as a primary determinant of decamer formation, as discussed further below. Studies with several typical 2-Cys Prxs suggested that high ionic strength promoted decamer formation (Kitano *et al.*, 1999; König *et al.*, 2002). In a related finding, *Mycobacterium tuberculosis* AhpC optimally formed decamers at 250 mM NaCl, with higher concentrations apparently promoting dissociation (Chauhan and Mande, 2001). A similar salt dependence was not observed, on the other hand, in oligomerization of *S. typhimurium* AhpC (Wood *et al.*, 2002). Such observed differences in the link between ionic strength and oligomeric state may reflect the individual properties of typical 2-Cys Prxs from different organisms and/or may have been influenced by the poly-histidine tag present on the recombinant proteins in two of these studies (Chauhan and Mande, 2001; König *et al.*, 2002).

A direct link between redox state and oligomerization state was established in 2002 for two bacterial AhpC proteins using analytical ultracentrifugation studies (Reynolds *et al.*, 2002; Wood *et al.*, 2002). In detailed studies of *S. typhimurium* AhpC, the reduced protein was found to be decameric at all concentrations studied (down to 2.5  $\mu$ M as the lowest concentration), whereas the oxidized protein had an increased propensity to dissociate, forming dimers at the lowest concentration, decamers at the highest (480  $\mu$ M) and a complex mixture of intermediate species in between (Wood *et al.*, 2002). Similar investigations of Cp20, a typical 2-Cys Prx from *C. pasteurianum*, yielded only dimers for oxidized protein up to 50  $\mu$ M and a mixture of higher molecular weight species for reduced protein, showing a very similar redox dependence, but suggesting an overall weaker dimer-dimer interface for Cp20 relative to *S. typhimurium* AhpC (Reynolds *et al.*, 2002). That disulfide bond formation results in a loss in stability for the decamer is consistent with the demonstration that oxidized PrxI crystallized as a dimer (Hirotsu *et al.*, 1999), whereas reduced, overoxidized and Cys-mutated typical 2-Cys Prxs crystallized as decamers (Alphey *et al.*, 2000; Schröder *et al.*, 2000; Wood *et al.*, 2003a).

In typical 2-Cys Prxs, disulfide bond formation at the active site destabilized decamers because the active site loop-helix in its fully folded conformation acts to buttress the decamer-building interface (Wood *et al.*, 2002). In a reciprocal manner, the presence of the adjacent dimer at the decamer-building interface would be expected to contribute to stabilization of the fully folded active site, suggesting a potentially important interaction between decamer formation and catalytic efficiency of these enzymes. Indeed, several earlier studies had suggested that dimers exhibited lower peroxidase activity than did decamers, although contributions from other solution components (e.g. salt) could not be ruled out (Nogoceke *et al.*, 1997; Kitano *et al.*, 1999; Chauhan and Mande, 2001). Another study of a plant chloroplast typical 2-Cys Prx, BasI, suggested the opposite, that decamer formation lowered catalytic rates, again using variable salt concentrations to promote association; the authors of this study concluded, however, that their results reflected the specific influence of oligomeric state on the rate-limiting reduction step rather than the peroxide reduction step, i.e., that dimers are more readily reduced than decamers (König *et al.*, 2003).



In order to more directly test the influence of oligomeric state on catalysis of peroxide reduction, Parsonage *et al.* (2005) generated several proteins mutated at a residue in *S. typhimurium* AhpC, Thr77, predicted to strongly influence the ability of the protein to form decamers (due to its proximity to its own counterpart, Thr77', in the subunit across the dimer-dimer interface). Indeed, loss of the buttressing effect on the active site in now dimeric T77I and T77D mutants had a significant impact on catalysis, lowering the catalytic efficiency of peroxide reduction ( $k_{\text{cat}}/K_m$  for  $\text{H}_2\text{O}_2$ ) by two orders of magnitude. This effect was predominantly the result of an increased  $K_m$  value for  $\text{H}_2\text{O}_2$ , consistent with the expectation that dimeric enzymes have less well formed active site pockets that can, nonetheless, be driven to adopt the normal fully folded active site configuration in the presence of high substrate concentrations (Parsonage *et al.*, 2005). Another mutant protein, T77V, did not disrupt but rather strengthened somewhat the interactions between dimers at the decamer-building interface and was, if anything, slightly more active toward  $\text{H}_2\text{O}_2$  than the wild type enzyme.

Though significantly destabilized as decamers in solution (as assessed by analytical ultracentrifugation studies), T77I and T77D mutants both crystallized as decamers. Structural effects of the mutations on packing at the decamer-building interface were generally subtle, although analyses of B-factors uncovered an interesting effect of the T77D mutation on mobility around the active site loop-helix; higher B-factors were observed from residues 43 through 55 (including the  $C_p$ , Cys46), whereas B-factors in the region surrounding the mutation at Thr77 did not change significantly (Parsonage *et al.*, 2005). This observation further supports a link between active site loop dynamics and structural interactions at the dimer-dimer interface within decameric AhpC.

If decamer disruption and an associated increase in propensity toward local unfolding at the active site loop-helix is indeed the origin of the lowered catalytic efficiency of T77I and T77D mutants of AhpC, then these mutant proteins should also exhibit more facile disulfide bond formation and thus a decreased tendency to succumb to oxidative inactivation by peroxide. This was indeed the outcome when the same mutants were tested for inactivation during turnover at high substrate concentration; T77V, the decameric mutant, exhibited about the same sensitivity toward peroxide-mediated inactivation as did wild type AhpC, whereas T77I and T77D mutants were much less prone toward this inactivation (Parsonage *et al.*, 2005). Thus there is a delicate balance of factors affecting oligomeric state and active site loop dynamics that also balance functional aspects of catalysis and regulation within 2-Cys Prxs like AhpC.

The extent to which the activity – oligomerization linkage observed for AhpC applies to other Prxs is not yet clear. The considerable sequence and structural similarities among typical 2-Cys Prxs suggests that other members will have a similar linkage, as well. In a potential connection with the above studies, cell cycle-dependent phosphorylation detected in mammalian Prxs (Thr90 in PrxI and Thr89 in PrxII) reportedly decreases Prx activity (Chang *et al.*, 2002); this may be a reflection of effects similar to the T77D mutation in AhpC in destabilizing decamers due

to the proximity of these residues and modifications across the decamer-building interface (Wood *et al.*, 2003b). As current evidence also supports the need for local unfolding around the active site for recycling of the sulfenic acid form of C<sub>P</sub> in all classes of Prxs, some level of linkage between activity and quaternary structure may be common to all Prxs with this A-type interface.

## 6. CONCLUSIONS

Prxs carry out the efficient reduction of a typically broad range of peroxide substrates through an absolutely conserved, activated Cys residue within a highly conserved active site pocket structure. Though details of reductive recycling after Cys sulfenic acid formation at the active site vary among members of different Prx classes, local unfolding around the active site Cys is likely generally required for disulfide bond formation with a second resolving Cys and/or for access of the reductant to the oxidized active site. The conformational change associated with the catalytic cycle and the redox-dependent decamer formation occurring in at least some typical 2-Cys Prxs have interesting implications in the interplay between active site loop dynamics, oligomerization state, catalytic efficiency and propensity toward inactivation during turnover in these important antioxidant enzymes.

## ACKNOWLEDGEMENTS

The author thanks Andy Karplus and Derek Parsonage for editorial suggestions. The research of the author is supported by grants from the National Institutes of Health (RO1 GM050389 and R21 CA112145 to Poole, and RO1 GM 072866 to W. Todd Lowther), from the National Science Foundation (MCB 0517343 to Jacquelyn Fetrow), and from a Joint Mathematical Biology Initiative from the Division of Mathematical Sciences-National Science Foundation and National Institute of General Medical Sciences (funded as RO1 GM075304 to Fetrow).

## REFERENCES

- Akerman, S.E., and Müller, S., 2005, Peroxiredoxin-linked detoxification of hydroperoxides in *Toxoplasma gondii*. *J. Biol. Chem.* **280**: 564–570.
- Alphey, M.S., Bond, C.S., Tetaud, E., Fairlamb, A.H., and Hunter, W.N., 2000, The structure of reduced trypanothione peroxidase reveals a decamer and insight into reactivity of 2Cys-peroxiredoxins. *J. Mol. Biol.* **300**: 903–916.
- Baker, L.M., and Poole, L.B., 2003, Catalytic mechanism of thiol peroxidase from *Escherichia coli*. Sulfenic acid formation and overoxidation of essential CYS61. *J. Biol. Chem.* **278**: 9203–9211.
- Biteau, B., Labarre, J., and Toledano, M.B., 2003, ATP-dependent reduction of cysteine-sulphinic acid by *S. cerevisiae* sulphiredoxin. *Nature* **425**: 980–984.
- Breinig, S., Kervinen, J., Stith, L., Wasson, A.S., Fairman, R., Wlodawer, A., Zdanov, A., and Jaffe, E.K., 2003, Control of tetrapyrrole biosynthesis by alternate quaternary forms of porphobilinogen synthase. *Nat. Struct. Biol.* **10**: 757–763.
- Bryk, R., Griffin, P., and Nathan, C., 2000, Peroxynitrite reductase activity of bacterial peroxiredoxins. *Nature* **407**: 211–215.

- Bryk, R., Lima, C.D., Erdjument-Bromage, H., Tempst, P., and Nathan, C., 2002, Metabolic enzymes of mycobacteria linked to antioxidant defense by a thioredoxin-like protein. *Science* **295**: 1073–1077.
- Budanov, A.V., Sablina, A.A., Feinstein, E., Koonin, E.V., and Chumakov, P.M., 2004, Regeneration of peroxiredoxins by p53-regulated sestrins, homologs of bacterial AhpD. *Science* **304**: 596–600.
- Budde, H., Flohé, L., Hecht, H.J., Hofmann, B., Stehr, M., Wissing, J., and Lünsdorf, H., 2003a, Kinetics and redox-sensitive oligomerisation reveal negative subunit cooperativity in trypanedoxin peroxidase of *Trypanosoma brucei brucei*. *Biol. Chem.* **384**: 619–633.
- Budde, H., Flohé, L., Hofmann, B., and Nimtz, M., 2003b, Verification of the interaction of a trypanedoxin peroxidase with trypanedoxin by ESI-MS/MS. *Biol. Chem.* **384**: 1305–1309.
- Cha, M.K., Kim, W.C., Lim, C.J., Kim, K., and Kim, I.H., 2004, *Escherichia coli* periplasmic thiol peroxidase acts as lipid hydroperoxide peroxidase and the principal antioxidative function during anaerobic growth. *J. Biol. Chem.* **279**: 8769–8778.
- Cha, M.K., Yun, C.H., and Kim, I.H., 2000, Interaction of human thiol-specific antioxidant protein 1 with erythrocyte plasma membrane. *Biochemistry* **39**: 6944–6950.
- Chae, H.Z., Chung, S.J., and Rhee, S.G., 1994, Thioredoxin-dependent peroxide reductase from yeast. *J. Biol. Chem.* **269**: 27670–27678.
- Chae, H.Z., Robison, K., Poole, L.B., Church, G., Storz, G., and Rhee, S.G., 1994, Cloning and sequencing of thiol-specific antioxidant from mammalian brain: alkyl hydroperoxide reductase and thiol-specific antioxidant define a large family of antioxidant enzymes. *Proc. Natl. Acad. Sci. USA* **91**: 7017–7021.
- Chang, T.S., Jeong, W., Choi, S.Y., Yu, S., Kang, S.W., and Rhee, S.G., 2002, Regulation of peroxiredoxin I activity by Cdc2-mediated phosphorylation. *J Biol Chem* **277**: 25370–25376.
- Chauhan, R., and Mande, S.C., 2001, Characterization of the *Mycobacterium tuberculosis* H37Rv alkyl hydroperoxidase AhpC points to the importance of ionic interactions in oligomerization and activity. *Biochem. J.* **354**: 209–215.
- Chen, J.W., Dodia, C., Feinstein, S.I., Jain, M.K., and Fisher, A.B., 2000, 1-Cys peroxiredoxin, a bifunctional enzyme with glutathione peroxidase and phospholipase A2 activities. *J. Biol. Chem.* **275**: 28421–28427.
- Choi, H.J., Kang, S.W., Yang, C.H., Rhee, S.G., and Ryu, S.E., 1998, Crystal structure of a novel human peroxidase enzyme at 2.0 Å resolution. *Nat Struct. Biol.* **5**: 400–406.
- Choi, Y.O., Cheong, N.E., Lee, K.O., Jung, B.G., Hong, C.H., Jeong, J.H., Chi, Y.H., Kim, K., Cho, M.J., and Lee, S.Y., 1999, Cloning and expression of a new isotype of the peroxiredoxin gene of Chinese cabbage and its comparison to 2Cys-peroxiredoxin isolated from the same plant. *Biochem. Biophys. Res. Commun.* **258**: 768–771.
- Christman, M.F., Morgan, R.W., Jacobson, F.S., and Ames, B.N., 1985, Positive control of a regulon for defenses against oxidative stress and some heat-shock proteins in *Salmonella typhimurium*. *Cell* **41**: 753–762.
- Comtois, S.L., Gidley, M.D., and Kelly, D.J., 2003, Role of the thioredoxin system and the thiol-peroxidases Tpx and Bcp in mediating resistance to oxidative and nitrosative stress in *Helicobacter pylori*. *Microbiology* **149**: 121–129.
- Copley, S.D., Novak, W.R., and Babbitt, P.C., 2004, Divergence of function in the thioredoxin fold superfamily: evidence for evolution of peroxiredoxins from a thioredoxin-like ancestor. *Biochemistry* **43**: 13981–13995.
- Deponte, M., and Becker, K., 2005, Biochemical characterization of *Toxoplasma gondii* 1-Cys peroxiredoxin 2 with mechanistic similarities to typical 2-Cys Prx. *Mol. Biochem. Parasitol.* **140**: 87–96.
- Dietz, K.J., 2003, Plant peroxiredoxins. *Annu. Rev. Plant Biol.* **54**: 93–107.
- Dubuisson, M., Vander Stricht, D., Clippe, A., Etienne, F., Nauser, T., Kissner, R., Koppenol, W.H., Rees, J.F., and Knoops, B., 2004, Human peroxiredoxin 5 is a peroxynitrite reductase. *FEBS Lett.* **571**: 161–165.
- Ellis, H.R., and Poole, L.B., 1997, Roles for the two cysteine residues of AhpC in catalysis of peroxide reduction by alkyl hydroperoxide reductase from *Salmonella typhimurium*. *Biochemistry* **36**: 13349–13356.

- Ferrante, A.A., Augliera, J., Lewis, K., and Klivanov, A.M., 1995, Cloning of an organic solvent-resistance gene in *Escherichia coli*: the unexpected role of alkylhydroperoxide reductase. *Proc. Natl. Acad. Sci. U S A* **92**: 7617–7621.
- Fisher, A.B., Dodia, C., Manevich, Y., Chen, J.W., and Feinstein, S.I., 1999, Phospholipid hydroperoxides are substrates for non-selenium glutathione peroxidase. *J. Biol. Chem.* **274**: 21326–21334.
- Flohé, L., Budde, H., Bruns, K., Castro, H., Clos, J., Hofmann, B., Kansal-Kalavar, S., Krumme, D., Menge, U., Plank-Schumacher, K., Sztajer, H., Wissing, J., Wylegalla, C., and Hecht, H.J., 2002, Tryparedoxin peroxidase of *Leishmania donovani*: molecular cloning, heterologous expression, specificity, and catalytic mechanism. *Arch. Biochem. Biophys.* **397**: 324–335.
- Fomenko, D.E., and Gladyshev, V.N., 2003, Identity and functions of CxxC-derived motifs. *Biochemistry* **42**: 11214–11225.
- Greenberg, J.T., and Demple, B., 1988, Overproduction of peroxide-scavenging enzymes in *Escherichia coli* suppresses spontaneous mutagenesis and sensitivity to redox-cycling agents in *oxyR*-mutants. *Embo J.* **7**: 2611–2617.
- Hirotsu, S., Abe, Y., Okada, K., Nagahara, N., Hori, H., Nishino, T., and Hakoshima, T., 1999, Crystal structure of a multifunctional 2-Cys peroxidoredoxin heme-binding protein 23 kDa/proliferation-associated gene product. *Proc. Natl. Acad. Sci. U S A* **96**: 12333–12338.
- Hofmann, B., Hecht, H.-J., and Flohé, L., 2002, Peroxiredoxins. *Biol Chem* **383**: 347–364.
- Jacobson, F.S., Morgan, R.W., Christman, M.F., and Ames, B.N., 1989, An alkyl hydroperoxide reductase from *Salmonella typhimurium* involved in the defense of DNA against oxidative damage. Purification and properties. *J. Biol. Chem.* **264**: 1488–1496.
- Jaeger, T., Budde, H., Flohé, L., Menge, U., Singh, M., Trujillo, M., and Radi, R., 2004, Multiple thioredoxin-mediated routes to detoxify hydroperoxides in *Mycobacterium tuberculosis*. *Arch. Biochem. Biophys.* **423**: 182–191.
- Jang, H.H., Lee, K.O., Chi, Y.H., Jung, B.G., Park, S.K., Park, J.H., Lee, J.R., Lee, S.S., Moon, J.C., Yun, J.W., Choi, Y.O., Kim, W.Y., Kang, J.S., Cheong, G.W., Yun, D.J., Rhee, S.G., Cho, M.J., and Lee, S.Y., 2004, Two enzymes in one; two yeast peroxiredoxins display oxidative stress-dependent switching from a peroxidase to a molecular chaperone function. *Cell* **117**: 625–635.
- Jeong, J.S., Kwon, S.J., Kang, S.W., Rhee, S.G., and Kim, K., 1999, Purification and characterization of a second type thioredoxin peroxidase (type II TPx) from *Saccharomyces cerevisiae*. *Biochemistry* **38**: 776–783.
- Jeong, W., Cha, M.K., and Kim, I.H., 2000, Thioredoxin-dependent hydroperoxide peroxidase activity of bacterioferritin comigratory protein (BCP) as a new member of the thiol-specific antioxidant protein (TSA)/Alkyl hydroperoxide peroxidase C (AhpC) family. *J. Biol. Chem.* **275**: 2924–2930.
- Kang, S.W., Baines, I.C., and Rhee, S.G., 1998, Characterization of a mammalian peroxiredoxin that contains one conserved cysteine. *J Biol Chem* **273**: 6303–6311.
- Kim, K., Kim, I.H., Lee, K.Y., Rhee, S.G., and Stadtman, E.R., 1988, The isolation and purification of a specific "protector" protein which inhibits enzyme inactivation by a thiol/Fe(III)/O<sub>2</sub> mixed-function oxidation system. *J. Biol. Chem.* **263**: 4704–4711.
- Kim, S.J., Woo, J.R., Hwang, Y.S., Jeong, D.G., Shin, D.H., Kim, K., and Ryu, S.E., 2003, The tetrameric structure of *Haemophilus influenzae* hybrid Prx5 reveals interactions between electron donor and acceptor proteins. *J. Biol. Chem.* **278**: 10790–10798.
- Kitano, K., Niimura, Y., Nishiyama, Y., and Miki, K., 1999, Stimulation of peroxidase activity by decamerization related to ionic strength: AhpC protein from *Amphibacillus xylanus*. *J. Biochem. (Tokyo)* **126**: 313–319.
- Kong, W., Shiota, S., Shi, Y., Nakayama, H., and Nakayama, K., 2000, A novel peroxiredoxin of the plant *Sedum lineare* is a homologue of *Escherichia coli* bacterioferritin co-migratory protein (Bcp). *Biochem. J.* **351**: 107–114.
- König, J., Baier, M., Horling, F., Kahmann, U., Harris, G., Schurmann, P., and Dietz, K.J., 2002, The plant-specific function of 2-Cys peroxiredoxin-mediated detoxification of peroxides in the redox-hierarchy of photosynthetic electron flux. *Proc. Natl. Acad. Sci. U S A* **99**: 5738–5743.

- König, J., Lotte, K., Plessow, R., Brockhinke, A., Baier, M., and Dietz, K.J., 2003, Reaction mechanism of plant 2-Cys peroxiredoxin. Role of the C terminus and the quaternary structure. *J. Biol. Chem.* **278**: 24409–24420.
- Koo, K.H., Lee, S., Jeong, S.Y., Kim, E.T., Kim, H.J., Song, K., and Chae, H.-Z., 2002, Regulation of thioredoxin peroxidase activity by C-terminal truncation. *Arch. Biochem. Biophys.* **397**: 312–318.
- Koshkin, A., Nunn, C.M., Djordjevic, S., and Ortiz de Montellano, P.R., 2003, The mechanism of *Mycobacterium tuberculosis* alkylhydroperoxidase AhpD as defined by mutagenesis, crystallography, and kinetics. *J. Biol. Chem.* **278**: 29502–29508.
- Kristensen, P., Rasmussen, D.E., and Kristensen, B.I., 1999, Properties of thiol-specific anti-oxidant protein or calpromotin in solution. *Biochem. Biophys. Res. Commun.* **262**: 127–131.
- Lee, J., Spector, D., Godon, C., Labarre, J., and Toledano, M.B., 1999, A new antioxidant with alkyl hydroperoxide defense properties in yeast. *J. Biol. Chem.* **274**: 4537–4544.
- Manevich, Y., Feinstein, S.I., and Fisher, A.B., 2004, Activation of the antioxidant enzyme 1-CYS peroxiredoxin requires glutathionylation mediated by heterodimerization with pi GST. *Proc. Natl. Acad. Sci. U S A* **101**: 3780–3785.
- Meissner, U., Schröder, E., Scheffler, D., Martin, A.G., and Harris, J.R., 2006, Formation, TEM study and 3D reconstruction of the human erythrocyte peroxiredoxin-2 dodecahedral higher-order assembly. *Micron*, **38**: 29–39.
- Mitsumoto, A., Takanezawa, Y., Okawa, K., Iwamatsu, A., and Nakagawa, Y., 2001, Variants of peroxiredoxins expression in response to hydroperoxide stress. *Free Radic. Biol. Med* **30**: 625–635.
- Montemartini, M., Kalisz, H.M., Hecht, H.J., Steinert, P., and Flohé, L., 1999, Activation of active-site cysteine residues in the peroxiredoxin-type trypanothione peroxidase of *Crithidia fasciculata*. *Eur. J. Biochem.* **264**: 516–524.
- Moon, J.C., Hah, Y.S., Kim, W.Y., Jung, B.G., Jang, H.H., Lee, J.R., Kim, S.Y., Lee, Y.M., Jeon, M.G., Kim, C.W., Cho, M.J., and Lee, S.Y., 2005, Oxidative stress-dependent structural and functional switching of a human 2-Cys peroxiredoxin isotype II that enhances HeLa cell resistance to H<sub>2</sub>O<sub>2</sub>-induced cell death. *J. Biol. Chem.* **280**: 28775–28784.
- Nogoceke, E., Gommel, D.U., Kiess, M., Kalisz, H.M., and Flohe, L., 1997, A unique cascade of oxidoreductases catalyses trypanothione-mediated peroxide metabolism in *Crithidia fasciculata*. *Biol Chem* **378**: 827–836.
- Nunn, C.M., Djordjevic, S., Hillas, P.J., Nishida, C.R., and Ortiz de Montellano, P.R., 2002, The crystal structure of *Mycobacterium tuberculosis* alkylhydroperoxidase AhpD, a potential target for antitubercular drug design. *J. Biol. Chem.* **277**: 20033–20040.
- Park, S.G., Cha, M.K., Jeong, W., and Kim, I.H., 2000, Distinct physiological functions of thiol peroxidase isoenzymes in *Saccharomyces cerevisiae*. *J. Biol. Chem.* **275**: 5723–5732.
- Parsonage, D., Youngblood, D.S., Sarma, G.N., Wood, Z.A., Karplus, P.A., and Poole, L.B., 2005, Analysis of the link between enzymatic activity and oligomeric state in AhpC, a bacterial peroxiredoxin. *Biochemistry* **44**: 10583–10592.
- Pedrajas, J.R., Miranda-Vizuete, A., Javanmardy, N., Gustafsson, J.A., and Spyrou, G., 2000, Mitochondria of *Saccharomyces cerevisiae* contain one-conserved cysteine type peroxiredoxin with thioredoxin peroxidase activity. *J. Biol. Chem.* **275**: 16296–16301.
- Peshenko, I.V., and Shichi, H., 2001, Oxidation of active center cysteine of bovine 1-Cys peroxiredoxin to the cysteine sulfenic acid form by peroxide and peroxyxynitrite. *Free Radic. Biol. Med.* **31**: 292–303.
- Plishker, G.A., Chevalier, D., Seinoth, L., and Moore, R.B., 1992, Calcium-activated potassium transport and high molecular weight forms of calpromotin. *J. Biol. Chem.* **267**: 21839–21843.
- Poole, L.B., 1999, Flavin-linked redox components required for AhpC reduction in alkyl hydroperoxide reductase systems. In *Flavins and Flavoproteins 1999* (Ghisla, S., Kroneck, P., Macheroux, P., and Sund, H., eds), Agency for Scientific Publications, Berlin, pp. 691–694.
- Poole, L.B., 2003, Bacterial peroxiredoxins. In *Signal Transduction by Reactive Oxygen and Nitrogen Species: Pathways and Chemical Principles* (Torres, M., Fukuto, J. M., and Forman, H. J., eds), Kluwer Academic Publishers, Dordrecht, The Netherlands, pp. 80–101.
- Poole, L.B., 2005, Bacterial defenses against oxidants: mechanistic features of cysteine-based peroxidases and their flavoprotein reductases. *Arch. Biochem. Biophys.* **433**: 240–254.

- Poole, L.B., Reynolds, C.M., Wood, Z.A., Karplus, P.A., Ellis, H.R., and Li Calzi, M., 2000, AhpF and other NADH:peroxiredoxin oxidoreductases, homologues of low  $M_r$  thioredoxin reductase. *Eur. J. Biochem.* **267**: 6126–6133.
- Rabilloud, T., Heller, M., Gasnier, F., Luche, S., Rey, C., Aebersold, R., Benahmed, M., Louisot, P., and Lunardi, J., 2002, Proteomics analysis of cellular response to oxidative stress. Evidence for in vivo overoxidation of peroxiredoxins at their active site. *J. Biol. Chem.* **277**: 19396–19401.
- Ralat, L.A., Manevich, Y., Fisher, A.B., and Colman, R.F., 2006, Direct evidence for the formation of a complex between 1-cysteine peroxiredoxin and glutathione S-transferase pi with activity changes in both enzymes. *Biochemistry* **45**: 360–372.
- Reynolds, C.M., Meyer, J., and Poole, L.B., 2002, An NADH-dependent bacterial thioredoxin reductase-like protein in conjunction with a glutaredoxin homologue form a unique peroxiredoxin (AhpC) reducing system in *Clostridium pasteurianum*. *Biochemistry* **41**: 1990–2001.
- Rhee, S.G., Chae, H.Z., and Kim, K., 2005, Peroxiredoxins: a historical overview and speculative preview of novel mechanisms and emerging concepts in cell signaling. *Free Radic. Biol. Med.* **38**: 1543–1552.
- Rouhier, N., Gelhaye, E., Gualberto, J.M., Jordy, M.N., De Fay, E., Hirasawa, M., Duplessis, S., Lemaire, S.D., Frey, P., Martin, F., Manieri, W., Knaff, D.B., and Jacquot, J.P., 2004, Poplar peroxiredoxin Q. A thioredoxin-linked chloroplast antioxidant functional in pathogen defense. *Plant Physiol.* **134**: 1027–1038.
- Rouhier, N., Gelhaye, E., and Jacquot, J.P., 2002, Glutaredoxin-dependent peroxiredoxin from poplar: protein-protein interaction and catalytic mechanism. *J. Biol. Chem.* **277**: 13609–13614.
- Rouhier, N., and Jacquot, J.P., 2005, The plant multigenic family of thiol peroxidases. *Free Radic. Biol. Med.* **38**: 1413–1421.
- Sarma, G.N., Nickel, C., Rahlfs, S., Fischer, M., Becker, K., and Karplus, P.A., 2005, Crystal structure of a novel *Plasmodium falciparum* 1-Cys peroxiredoxin. *J. Mol. Biol.* **346**: 1021–1034.
- Sayed, A.A., and Williams, D.L., 2004, Biochemical characterization of 2-Cys peroxiredoxins from *Schistosoma mansoni*. *J. Biol. Chem.* **279**: 26159–26166.
- Schröder, E., Littlechild, J.A., Lebedev, A.A., Errington, N., Vagin, A.A., and Isupov, M.N., 2000, Crystal structure of decameric 2-Cys peroxiredoxin from human erythrocytes at 1.7 Å resolution. *Structure* **8**: 605–615.
- Schröder, E., Willis, A.C., and Ponting, C.P., 1998, Porcine natural-killer-enhancing factor-B: oligomerisation and identification as a calpain substrate in vitro. *Biochim. Biophys. Acta* **1383**: 279–291.
- Seaver, L.C., and Imlay, J.A., 2001, Alkyl hydroperoxide reductase is the primary scavenger of endogenous hydrogen peroxide in *Escherichia coli*. *J. Bacteriol.* **183**: 7173–7181.
- Söhling, B., Parther, T., Rucknagel, K.P., Wagner, M.A., and Andreesen, J.R., 2001, A selenocysteine-containing peroxiredoxin from the strictly anaerobic organism *Eubacterium acidaminophilum*. *Biol. Chem.* **382**: 979–986.
- Torchinsky, Y.M., 1981, Properties of SH groups, in *Sulfur in Proteins* (Metzler, D., ed), Pergamon, Oxford, England
- Trujillo, M., Budde, H., Pineyro, M.D., Stehr, M., Robello, C., Flohé, L., and Radi, R., 2004, *Trypanosoma brucei* and *Trypanosoma cruzi* tryparedoxin peroxidases catalytically detoxify peroxynitrite via oxidation of fast reacting thiols. *J. Biol. Chem.* **279**: 34175–34182.
- Trujillo, M., Mauri, P., Benazzi, L., Comini, M., De Palma, A., Flohé, L., Radi, R., Stehr, M., Singh, M., Ursini, F., and Jaeger, T., 2006, The mycobacterial thioredoxin peroxidase can act as a one-cysteine-peroxiredoxin. *J. Biol. Chem.*
- Verdoucq, L., Vignols, F., Jacquot, J.P., Chartier, Y., and Meyer, Y., 1999, In vivo characterization of a thioredoxin h target protein defines a new peroxiredoxin family. *J. Biol. Chem.* **274**: 19714–19722.
- Vergauwen, B., Pauwels, F., Jacquemotte, F., Meyer, T.E., Cusanovich, M.A., Bartsch, R.G., and Van Beeumen, J.J., 2001, Characterization of glutathione amide reductase from *Chromatium gracile*. Identification of a novel thiol peroxidase (Prx/Grx) fueled by glutathione amide redox cycling. *J. Biol. Chem.* **276**: 20890–20897.
- Winterbourn, C.C., and Metodieva, D., 1999, Reactivity of biologically important thiol compounds with superoxide and hydrogen peroxide. *Free Radic. Biol. Med.* **27**: 322–328.

- Wood, Z.A., Poole, L.B., Hantgan, R.R., and Karplus, P.A., 2002, Dimers to doughnuts: redox-sensitive oligomerization of 2-cysteine peroxiredoxins. *Biochemistry* **41**: 5493–5504.
- Wood, Z.A., Poole, L.B., and Karplus, P.A., 2003a, Peroxiredoxin evolution and the regulation of hydrogen peroxide signaling. *Science* **300**: 650–653.
- Wood, Z.A., Schröder, E., Harris, J.R., and Poole, L.B., 2003b, Structure, mechanism and regulation of peroxiredoxins. *Trends Biochem. Sci.* **28**: 32–40.
- Yang, K.S., Kang, S.W., Woo, H.A., Hwang, S.C., Chae, H.Z., Kim, K., and Rhee, S.G., 2002, Inactivation of human peroxiredoxin I during catalysis as the result of the oxidation of the catalytic site cysteine to cysteine-sulfinic acid. *J. Biol. Chem.* **277**: 38029–38036.

## CHAPTER 5

# KINETICS OF PEROXIREDOXINS AND THEIR ROLE IN THE DECOMPOSITION OF PEROXYNITRITE

MADIA TRUJILLO,<sup>1,2,\*</sup> GERARDO FERRER-SUETA,<sup>2,3</sup>  
LEONOR THOMSON,<sup>2,3</sup> LEOPOLD FLOHÉ<sup>4</sup> AND RAFAEL RADÍ<sup>1,2</sup>

<sup>1</sup>*Departamento de Bioquímica,*

<sup>2</sup>*Center for Free Radical and Biomedical Research, Facultad de Medicina, Universidad de la República, 11800 Montevideo, Uruguay*

<sup>3</sup>*Instituto de Química Biológica, Facultad de Ciencias, Universidad de la República, 11400 Montevideo, Uruguay, and*

<sup>4</sup>*MOLISA GmbH, Universitätsplatz 2, D-39106 Magdeburg, Germany*

**Abstract:** Methodologies and results of studies on the kinetics of peroxiredoxins (Prx) are reviewed. Peroxiredoxins are broad-spectrum peroxidases that catalyze the reduction of H<sub>2</sub>O<sub>2</sub>, organic hydroperoxides and peroxynitrite by thiols. Their catalytic cycle starts with the oxidation of a particularly reactive cysteine residue (C<sub>p</sub>) to a sulfenic acid derivative by the peroxide substrate, the sulfenic acid then reacts with a thiol to form a disulfide, and the cycle is completed by thiol/disulfide exchange reactions that regenerate the ground-state enzyme. Depending on the subtype of peroxiredoxin, the thiol reacting with the primary oxidation product (E-SOH) may be a cysteine residue of a second subunit (typical 2-Cys Prx), a cysteine residue of the same subunit (atypical 2-Cys Prx) or reducing substrate (1-Cys Prx and at least one example of an atypical 2-Cys Prx). In a typical 2-Cys Prx the intra-subunit disulfide formation with the second “resolving” cysteine (C<sub>R</sub>) is mandatory for the reduction by the specific substrate, which is a protein characterized by a CXXC motif such as thioredoxin, tryparedoxin or AhpF. These consecutive redox reactions define the catalysis as an enzyme substitution mechanism, which is corroborated by a ping-pong pattern that is commonly observed in steady-state analyses, chemical identification of catalytic intermediates and stopped-flow analyses of partial reactions. More complex kinetic patterns are discussed in terms of cooperativity between the subunits of the oligomeric enzymes, generation of different oxidized intermediates or partial over-oxidation of C<sub>p</sub> to a sulfinic acid. Saturation kinetics is often not observed indicating that a typical complex between reduced enzyme and hydroperoxide is not formed and that, in these cases, formation of the complex between the oxidized enzyme and its reducing substrate is slower than the reaction within this complex. Working with sulphur catalysis, Prxs are usually less efficient

---

\* To whom correspondence should be addressed to: Departamento de Bioquímica, Facultad de Medicina, Universidad de la República, General Flores 2125, 11800, Montevideo, Uruguay. E-mail: madiat@fmed.edu.uy



than the heme- or selenium-containing peroxidases, but in some cases the  $k_{+1}$  values (bimolecular rate constant for oxidation of reduced E by ROOH) are comparable, the overall range being  $2 \times 10^3$ – $4 \times 10^7$   $\text{M}^{-1}\text{s}^{-1}$  depending on the hydroperoxide and the individual Prx. For the reduction of peroxynitrite  $k_{+1}$  values of  $1 \times 10^6$  up to  $7 \times 10^7$   $\text{M}^{-1}\text{s}^{-1}$  have been measured. The net forward rate constants  $k'_{+2}$  for the reductive part of the cycle range between  $2 \times 10^4$ – $1 \times 10^7$   $\text{M}^{-1}\text{s}^{-1}$ . These kinetic characteristics qualify the peroxiredoxins as moderately efficient devices to detoxify hydroperoxides, which is pivotal to organisms devoid of more efficient peroxidases, and as most relevant to the detoxification of peroxynitrite. In higher organisms, their specific role is seen in the regulation of signalling cascades that are modulated by  $\text{H}_2\text{O}_2$ , lipid hydroperoxides or peroxynitrite

**Keywords:** Peroxiredoxin, Peroxynitrite, Peroxide, Oxidative stress, Kinetics

**Abbreviations:** Peroxiredoxins (Prxs), hydrogen peroxide ( $\text{H}_2\text{O}_2$ ), peroxidatic cysteine residue ( $\text{C}_\text{P}$ ), resolving cysteine residue ( $\text{C}_\text{R}$ ), cysteine sulfenic acid (Cys-SOH), superoxide anion ( $\text{O}_2^{\bullet-}$ ), nitric oxide ( $\bullet\text{NO}$ ), nitrate ( $\text{NO}_3^-$ ), hydroxyl radical ( $\bullet\text{OH}$ ), nitrogen dioxide ( $\bullet\text{NO}_2$ ), carbonate radical ( $\text{CO}_3^{\bullet-}$ ), peroxynitrous acid (ONOOH), peroxynitrite anion ( $\text{ONOO}^-$ ), thiolate anion ( $\text{RS}^-$ ), thiol (RSH), cytosolic trypanothione peroxidase (cTXNPrx), alkyl hydroperoxide reductase (Ahp), thioredoxin peroxidase (TPx), horseradish peroxidase (HRP), glutathione peroxidase 1 (GPx1),  $\text{Mn}^{\text{III}}$ -meso-tetrakis[(N-butyl)pyridinium-2-yl] porphyrin ( $\text{Mn}^{\text{III}}$ TB-2-PyP), dihydrochloride 123 (DHR)

## 1. INTRODUCTION

Peroxiredoxins (Prxs), like glutathione peroxidases, catalyze the reduction of hydrogen peroxide ( $\text{H}_2\text{O}_2$ ), organic hydroperoxides and peroxynitrite by thiols. This kind of reaction also occurs spontaneously, and the need of a catalytic acceleration of such turnover by any of the two types of enzyme has repeatedly been questioned. In fact, after the first description of a glutathione peroxidase (Mills, 1957) it took more than a decade until the physiological relevance of this enzyme became generally appreciated (Flohé, 1989). Similarly, the detoxification of hydroperoxides in trypanosomes, now known to be catalyzed by a peroxiredoxin system (see Chapter 9), had still in the 90s been attributed to spontaneous reduction by trypanothione (Carnieri *et al.*, 1993), and antioxidant defense or redox regulation by thioredoxin has not often been linked to peroxiredoxin catalysis except in the last decade. Although it has for long become evident that most mammalian peroxiredoxins are thioredoxin peroxidases (see Chapter 1), the term “peroxiredoxin” does not even show up in the subject index of the last two volumes of *Methods in Enzymology* (Vol. 252 and 347) that were dedicated to redox biochemistry of thioredoxins and other thiols. The reluctance to accept thiol-dependent peroxidases as enzymes of outstanding importance for antioxidant defense and redox regulation has now been, and could only be, overcome by quantitative kinetic data that allow the prediction of a relevant *in vivo* acceleration of reactions that meets the physiological requirements. It is the primary goal of this article to compile what has been achieved in this respect in the field of peroxiredoxins.

As is described in detail in Chapter 4, peroxiredoxins operate via thiol catalysis. According to the number of cysteinyl residues involved in catalysis, Prxs are classified into one-cysteine (1-Cys) Prxs or two-cysteine (2-Cys) Prxs. In the first catalytic step, which is common to all Prxs, the reactive peroxidatic cysteine residue<sup>1</sup> ( $C_P$ ) attacks the oxidizing substrate, resulting in the formation of a sulfenic acid (Cys-SOH) derivative of the enzyme. In the case of 1-Cys Prxs, this sulfenic acid derivative is directly reduced by the reducing substrate. In the case of 2-Cys Prxs, the mentioned sulfenic acid first reacts with a second cysteine residue, the resolving cysteine ( $C_R$ ), which can be present either in another subunit thus leading to the formation of an intermolecular disulfide bridge (in the case of typical 2-Cys Prxs) or in the same subunit, thus forming an intramolecular disulfide bridge (in the case of atypical 2-Cys Prxs). Then, this disulfide bridge in the oxidized form of the enzyme is reduced by the natural reductant (Fig. 1), in most cases thioredoxin.

Irrespective of the mechanistic differences between the three types of Prxs, the basic scheme of catalysis is the same for all of them: The enzyme is oxidized by a peroxide substrate and then the oxidized enzyme is reduced again. If the individual steps in this sequence of events occur independently of each other, as is common for all kind of peroxidases, this type of reaction, in chemical terms, is a typical example of an homogeneous catalysis that may tentatively be described as a sequence of two bimolecular reactions and, in enzymological terms, is known as “enzyme substitution mechanism” that can be evidenced as a double displacement (ping-pong) pattern under steady-state kinetic analysis (Dalziel, 1957). This kinetic behavior was indeed observed with peroxiredoxins, first for the cytosolic trypanoxin peroxidase (cTXNPx) of *Crithidia fasciculata* (Nogoceke *et al.*, 1997), and subsequently for many other peroxiredoxins including those of *Trypanosoma cruzi* cTXNPx (Guerrero *et al.*, 2000), *Helicobacter pylori* and *Salmonella typhimurium* alkyl hydroperoxide reductase C (AhpC) (Baker *et al.*, 2001; Parsonage *et al.*, 2005), *Leishmania donovani* cTXNPx (Flohé *et al.*, 2002), *Plasmodium falciparum* thioredoxin peroxidase 1 (TPx 1) (Akerman *et al.*, 2003), *Toxoplasma gondii* TPx 1 (Akerman *et al.*, 2005), *Escherichia coli* TPx (Baker *et al.*, 2003) and *Schistosoma mansoni* Prx 1 (Sayed *et al.*, 2004). But as is evident from Fig. 1, the actual catalytic cycle comprises more than just two elementary steps and the situation is further complicated by side reactions and the oligomeric nature of the peroxiredoxins. Accordingly, more complex kinetic patterns have recently been reported in the case of *Trypanosoma brucei* cTXNPx (Budde *et al.*, 2003), *Leishmania infantum* mitochondrial TXNPx (Castro *et al.*, 2004), *Mycobacterium tuberculosis* TPx (when utilizing MtTrxC as reducing substrate) (Jaeger *et al.*, 2004), as well as in the case of *Schistosoma mansoni* Prx 2 and Prx 3 (Sayed *et al.*, 2004). These deviations from a classical ping-pong pattern do not question the proposed enzyme substitution

---

<sup>1</sup> The peroxidatic cysteine residue is activated in a catalytic triad comprising a positively charged arginine residue with which the peroxidatic cysteine electrostatically interacts and, in most cases, a threonine residue, with which it forms a hydrogen bond. In consequence, peroxidatic cysteines in Prxs usually have a low  $pK_a$  and are deprotonated at physiological pH (see Chapters 3 and 4).

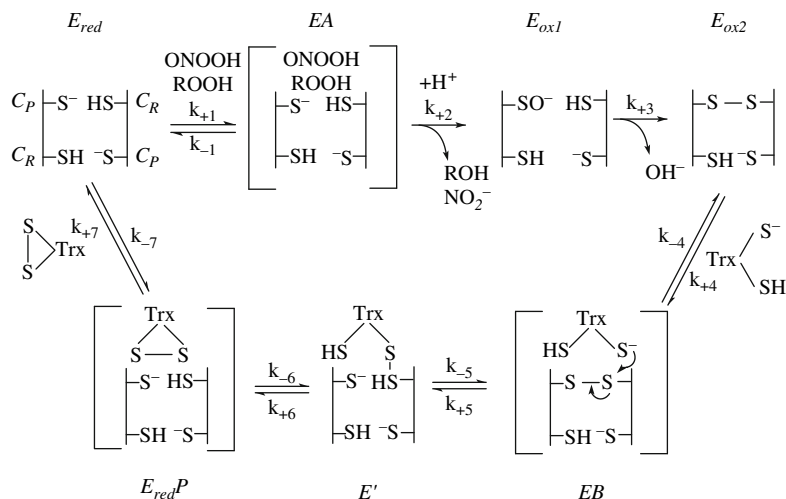

Figure 1. Scheme of the catalytic cycle of a typical 2-cysteine peroxidase. In this scheme, the catalytic mechanism for a typical 2-Cys Prx is shown. The oxidizing substrate ROOH associates with the reduced state ( $E_{red}$ ) forming a complex or transition state ( $EA$ ; see text), which leads to the oxidation of peroxidatic cysteine residue ( $C_P$ ) to an unstable sulfenic acid derivative ( $E_{ox1}$ ) and the release of the first product (ROH). The deprotonated sulfenic acid reacts with the resolving cysteine residue ( $C_R$ ) from an inversely oriented subunit to form an intermolecular disulfide bridge in the stable oxidized form of the enzyme ( $E_{ox2}$ ). In the lower part of the scheme the reductive part of the catalytic cycle is shown.  $E_{ox2}$  and the reducing substrate, most frequently thioredoxin, form a regular enzyme/substrate complex ( $EB$ ). Within this complex the thioredoxin attacks  $C_R$  with its solvent exposed dissociated cysteine to form a covalent intermediate between Prx and thioredoxin ( $E'$ ). By thiol disulfide reshuffling a complex between the reduced Prx ( $E_{red}$ ) and oxidized thioredoxin ( $E'$ ) is sequentially formed, where from oxidized thioredoxin and ground state enzyme is regenerated. Similar catalytic schemes can be drawn for atypical 2-Cys Prxs, where the disulfide bond in  $E_{ox2}$  is formed between  $C_P$  and the resolving cysteine residue in the same polypeptide chain, or for 1-Cys Prxs, where the sulfenic acid derivative of  $C_P$  ( $E_{ox1}$ ) is reduced directly by the donor substrate without previous formation of a disulfide bond within the enzyme

mechanism which has not only been deduced from various kinetic approaches but is also corroborated by chemical analysis of catalytic intermediates (see Chapter 4). However, they reveal considerable, in part physiologically interesting variations of the basic scheme.

## 2. GENERAL APPROACHES TO STUDY PEROXIREDOXIN KINETICS

The kinetics of the reactions catalyzed by Prxs has been studied by two complementary approaches, i.e. steady-state analysis in the presence of both the reducing and the oxidizing substrate and low, catalytic concentrations of the enzyme, or pre-steady state analysis of particular steps in the catalytic cycle. The two approaches yielded convergent results that also complied with independent analyses of catalytic

intermediates, with investigations of molecular mutants and, in many cases, with research related to the physiological relevance of the enzymes by inverse genetics.

## 2.1. Steady-state Kinetic Analysis

Bi-substrate reactions of oxidoreductases do not always obey the Michaelis-Menten equation. Instead, saturation by any of the substrates is often not observed, which makes it impossible to describe the enzymatic characteristics by conventional terms such as  $V_{\max}$  or  $K_M$  values. This kind of kinetic behavior is typical, e.g., for the selenium-containing glutathione peroxidases, catalases and superoxide dismutases, and is also observed with some, but by no means all of the peroxidoredoxins. For this reason, the data sets obtained from initial rate measurements under steady state conditions have mostly been analyzed by algorithms that are not *a priori* based on any defined mechanistic assumption, most frequently by the one introduced by Dalziel 1957 to analyze enzymatic bi-substrate reactions. Fitting the initial velocity data to the Dalziel equation (Eq. 1) yields empirical “coefficients” ( $\Phi$ )<sup>2</sup> which functionally characterize the enzyme, can be used to classify the mechanism of action and, depending on the mechanism, can be translated into  $V_{\max}$  and  $K_M$  values and more or less well defined rate constants.

$$(1) \quad [E]/v_0 = \Phi_0 + \Phi_1/[A] + \Phi_2/[B] + \Phi_{1,2}/([A][B])$$

In this equation  $[E]$  means the total enzyme molarity,  $v_0$  is the initial velocity obtained under the experimental conditions and  $[A]$  and  $[B]$  are the pertinent concentrations of the first and second substrate, respectively. If applicable, i. e. if  $\Phi_0$  differs from zero, the  $\Phi$  values can be expressed as more commonly used kinetic parameters such as  $K_M$  and  $V_{\max}$ , as is evident from the analogy of the Dalziel equation and the general rate equation, if the latter is written in its reciprocal form as for graphical analysis of double reciprocal plots (Eq. 2).

$$(2) \quad 1/v_0 = 1/V_{\max} + K_M^A/(V_{\max}[A]) + K_M^B/(V_{\max}[B]) + K_S^A K_M^B/(V_{\max}[A][B])$$

The physical meaning of the  $\Phi$  values in terms of rate constants depends on the mechanism, as do those of  $K_M$  values. For bi-substrate enzyme substitution mechanisms  $\Phi_{1,2}$ , which would characterize the formation of a (non-existing) ternary

<sup>2</sup> The  $\Phi$  values can be experimentally obtained from primary “Dalziel plots”, i. e. Lineweaver-Burk plots that are normalized for enzyme molarity:  $[E]/v_0$ , against  $1/[\text{substrate } A]$  at several fixed co-substrate concentration  $[B_1-B_3]$ . In case of a ping-pong mechanism, this primary plot yields parallel straight lines with slopes that equal  $\Phi_1$ , and apparent maximum velocities ( $V_{\max}^{\text{app}}$ ) and  $K_M^{\text{app}}$  values can be read from the ordinate and abscissa intercepts, respectively, as is schematically shown in Fig. 2A. If then the ordinate intercepts ( $[E]/V_{\max}^{\text{app}}$ ) are re-plotted against the pertinent concentrations of substrate B (secondary Dalziel plot; Fig. 2B), the real enzyme normalized  $V_{\max}$ , which equals  $1/\Phi_0$  and the real  $K_M^B$  is provided by the intercepts, while the slope equals  $\Phi_2$  and  $K_M^A$  can be calculated from  $\Phi_1 = K_M^A/V_{\max}$ .

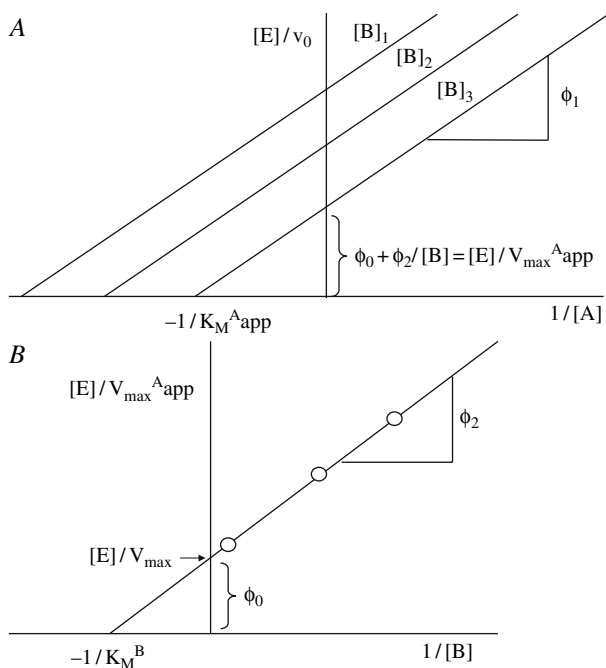

Figure 2. Schematic primary (A) and secondary (B) Dalziel plots of an enzymes substitution mechanism

complex composed by the enzyme and both substrates, is zero, and the equation simplifies to

$$(3) \quad [E]/v_0 = \Phi_0 + \Phi_1/[A] + \Phi_2/[B]$$

wherein  $\Phi_0$  is the reciprocal value of  $k_{cat}$  and  $\Phi_1$  and  $\Phi_2$  are the reciprocal values of the net forward rate constants,  $k_A'$  and  $k_B'$ , for the enzyme's reactions with substrate A (here ROOH) and B (TrxH<sub>2</sub> or the like), respectively. According to Dalziel's systematic analyses (Dalziel 1957),  $\Phi_1$  and  $\Phi_2$  can be further defined by the microscopic rate constants shown in the reaction scheme of Fig. 1 as follows:

$$(4) \quad \Phi_1 = (k_{-1} + k_{+2})/k_{+1} \quad k_{+2}$$

$$(5) \quad \Phi_2 = (k_{-4} + k_{+5})/k_{+4} \quad k_{+5}$$

As already mentioned, in some cases of peroxidoredoxin catalysis,  $\Phi_0$  is zero and equation 3 can be further simplified to

$$(6) \quad [E]/v_0 = \Phi_1/[A] + \Phi_2/[B]$$

and, ignoring the backward reactions, the  $\Phi$  values adopt the definitions

$$(7) \quad \Phi_1 = 1/k_{+1}$$

and

$$(8) \quad \Phi_2 = 1/k_{+4}$$

For those peroxiredoxins showing saturation kinetics  $\Phi_0$  or  $k_{\text{cat}}$ , respectively, may define any of the rate-limiting monomolecular rate constants of the cycle, i. e.  $k_{+2}$ ,  $k_{+3}$ ,  $k_{+5}$ , or  $k_{+6}$ , or hybrids thereof, if their numerical values are similar.

Which of the interpretations is applicable depends on the particular enzyme under consideration. Also, the reaction scheme shown in Fig. 1, which certainly represents the catalytic cycle of the most abundant 2-Cys Prxs, might not be valid for all members of the family. Moreover, deviations from the typical ping-pong pattern, as have more recently been detected in steady state analyses of several peroxiredoxins (see below), are still waiting for a convincing interpretation and might be due to different molecular phenomena.

For the first peroxiredoxin thus analyzed, tryparedoxin peroxidase of *Crithidia fasciculata* (CfTXNPx) (Nogoceke *et al.*, 1997), and later for several other examples (Table 1),  $\Phi_0$  proved to be zero, and as this coefficient is the reciprocal value of the catalytic constant,  $k_{\text{cat}}$ , a real maximum velocity (or real  $K_M$  values) could neither be measured nor extrapolated. In other words, enzyme saturation by any of the substrates cannot be achieved. In Dalziel's system of enzyme mechanisms (Dalziel, 1957) this kinetic pattern corresponds to a mechanism resulting from two independent consecutive redox reactions that do not involve the formation of any enzyme substrate complex. This pattern is however also compatible with a mechanism that involves complex formation, if the formation of complexes of enzyme or intermediate with substrate is much slower than any of the consecutive reactions within the complexes. As outlined above (Eqs. 7 and 8),  $\Phi_1$  in those cases approaches the reciprocal value of  $k_{+1}$  and  $\Phi_2$  the reciprocal value of  $k_{+4}$ . Whether enzyme/substrate complexes are involved or not can thus not be decided by kinetic measurements alone. Formation of a specific complex between CfTXNPx and the hydroperoxide substrate is indeed not very likely, since the enzyme promiscuously accepts almost any kind of hydroperoxide at rates that apparently reflect little else than sterical access of the hydroperoxo group to  $C_p$ . Complex formation with ROOH, as shown in Fig. 1, might therefore be better interpreted as kind of productive collision or transition state which results in oxidation of the enzyme's  $C_p$ . In contrast, the reductive part of the catalytic cycle must be mediated by a typical complex formation, since the enzyme is highly specific for its reducing substrate, here tryparedoxin. Thioredoxins and related proteins with a CXXC motif are not readily accepted by a TXNPx (Steinert *et al.*, 2000). The overall mechanism of CfTXNPx is thus very likely a hybrid enzyme substitution mechanism involving enzyme oxidation by hydroperoxide without real complex formation and enzyme reduction involving a complex formation with the reducing substrate, wherein the complex formation is rate-limiting ( $k_{+5} \gg k_{+4}$ ). This interpretation is further corroborated by the observation that saturation kinetics are observed with a molecular mutant of CfTXNPx that is functionally compromised by an exchange of its  $C_R$  against serine (Montemartini *et al.*, 1998). Due to this

Table 1. Selected kinetic parameters for peroxiredoxins

Enzyme <sup>a</sup>	$k'_A$ ( $M^{-1}s^{-1}$ )	$k'_B$ ( $M^{-1}s^{-1}$ )	$k_{cat}$ ( $s^{-1}$ )	$K_M^{ROOH}$ ( $\mu M$ )	$K_M^{red}$ ( $\mu M$ )	Ref.
<i>C. fasciculata</i> cytosolic TXNPx	$1.9 \times 10^5$	$2.0 \times 10^6$	$\infty^b$	$\infty^{b,c}$	$\infty^{b,f}$	(Nogoceke <i>et al.</i> 1997)
<i>T. cruzi</i> cytosolic TXNPx	$3.2 \times 10^4$	$1.0 \times 10^6$	1.7	51.8 <sup>c</sup>	1.7 <sup>g</sup>	(Guerrero <i>et al.</i> 2000)
<i>T. brucei</i> cytosolic TXNPx	$1.7 \times 10^7$	$1.1 \times 10^6$	5.0	0.3 <sup>c</sup>	4.6 <sup>h</sup>	(Builde <i>et al.</i> 2003)
<i>L. donovani</i> cytosolic TXNPx	$2.4 \times 10^5$	$2.1 \times 10^6$	7.1	30.5 <sup>c</sup>	3.4 <sup>f</sup>	(Flohé <i>et al.</i> 2002)
<i>L. infantum</i> mitochondrial TXNPx	$3.8 \times 10^6$	$1.2 \times 10^6$	33.3	9.2 <sup>c</sup>	31.9 <sup>g</sup>	(Castro <i>et al.</i> 2002)
<i>M. tuberculosis</i> TPx	$3.4 \times 10^{5i}$	$4.6 \times 10^{4i}$	0.7 <sup>i</sup>	2.0 <sup>c,i</sup>	14.5 <sup>i</sup>	(Jaeger <i>et al.</i> 2004)
	$0.9 \times 10^{5j}$	$5.8 \times 10^{4j}$	11.1 <sup>j</sup>	120.7 <sup>c,j</sup>	184.5 <sup>j</sup>	
<i>M. tuberculosis</i> AhpC	$0.9 \times 10^{4k}$	$2.7 \times 10^{6k}$	0.6 <sup>k</sup>	65.2 <sup>c,k</sup>	0.2 <sup>k</sup>	(Jaeger <i>et al.</i> 2004)
	$2.3 \times 10^{4j}$	$2.5 \times 10^{4j}$	0.1 <sup>j</sup>	5.6 <sup>c,j</sup>	5.1 <sup>j</sup>	
<i>H. pylori</i> AhpC	$2.0 \times 10^5$	$1.0 \times 10^5$	$\infty^b$	$\infty^{b,d}$	$\infty^{b,l}$	(Baker <i>et al.</i> 2001)
<i>S. typhimurium</i> AhpC	$3.9 \times 10^7s$	$1.0 \times 10^7s$	55.1	1.4 <sup>d</sup>	5.4 <sup>m</sup>	(Parsonage <i>et al.</i> 2005)
<i>E. coli</i> TPx	$4.4 \times 10^{4d,s}$	$3.0 \times 10^6s$	76.0 <sup>d</sup>	1730 <sup>d</sup>	25.5 <sup>l</sup>	(Baker <i>et al.</i> 2003)
	$7.7 \times 10^{6e,s}$	$3.1 \times 10^6s$	70.1 <sup>e</sup>	9.1 <sup>e</sup>	22.5 <sup>l</sup>	
<i>P. falciparum</i> TPx 1	$6.7 \times 10^{6s}$	$7.2 \times 10^5s$	9.7	0.8 <sup>d</sup>	18.9 <sup>l</sup>	(Akerman <i>et al.</i> 2003)
<i>P. falciparum</i> TPx 2 <sup>l</sup>	$6.8 \times 10^{6s}$	$2.8 \times 10^5s$	32.1 <sup>q</sup>	2.2 <sup>d</sup>	11.6 <sup>l</sup>	(Boucher <i>et al.</i> 2006)
<i>T. gondii</i> TPx 1 <sup>p,q</sup>	$7.0 \times 10^{6c,s}$	$4.9 \times 10^5s$	2.8 <sup>c</sup>	0.04 <sup>c</sup>	4.2 <sup>l</sup>	(Akerman <i>et al.</i> 2005)
	$2.2 \times 10^{6d,s}$		0.8 <sup>d</sup>	0.38 <sup>d</sup>		
<i>S. mansoni</i> Prx 1	$2.8 \times 10^{5d}$	$6.2 \times 10^{4d}$	$\infty^b$	$\infty^{b,c,d,e}$	$\infty^{b,n}$	(Sayed <i>et al.</i> 2004)
	$8.3 \times 10^{5c}$	$2.2 \times 10^{5c}$				
	$7.7 \times 10^{5e}$	$5.0 \times 10^{5e}$				

<i>Poplar</i> type II <sup>v</sup> peroxiredoxin	$8 \times 10^{4u}$ , s	ND	2.1 <sup>u</sup> 1.5 <sup>c</sup> 2.6 <sup>d</sup> 0.9 <sup>e</sup>	23 <sup>u</sup>	ND	(Routhier <i>et al.</i> 2004)
<i>Poplar</i> peroxiredoxin Q	$2.4 \times 10^{3c}$ , s $8.0 \times 10^{3d}$ , s $2.4 \times 10^{4e}$ , s $8.0 \times 10^{2c}$ , s	$6.0 \times 10^5$ $1.9 \times 10^5$ $1.6 \times 10^5$ ND	0.9 <sup>c</sup> 2.9 <sup>d</sup> 2.4 <sup>e</sup> 0.03 <sup>c</sup>	375.2 <sup>c</sup> 367.0 <sup>d</sup> 98.8 <sup>e</sup> 37.4 <sup>c</sup>	1.5 <sup>f</sup> ND	(Routhier <i>et al.</i> 2004)
<i>E. coli</i> bacterioferritin comigratory protein <sup>1, 9</sup>	$2.3 \times 10^{3d}$ , s $12.0 \times 10^{3w}$ , s > $2.2 \times 10^{5d}$ , s > $2.2 \times 10^{5e}$ , s		0.11 <sup>d</sup> 0.14 <sup>w</sup> 4.4 <sup>r</sup>	47.8 <sup>d</sup> 11.7 <sup>w</sup> < 20 <sup>d</sup> < 20 <sup>e</sup>	ND	(Jeong <i>et al.</i> 2000)
Human Prx I	> $1.0 \times 10^{5d}$ , s > $1.0 \times 10^{5e}$ , s	$8.0 \times 10^5$ $9.0 \times 10^5$	2.0 <sup>r</sup>	< 20 <sup>d</sup> < 20 <sup>e</sup>	5.5 <sup>o</sup> 2.7 <sup>o</sup>	(Chae <i>et al.</i> 1999) (Chae <i>et al.</i> 1999)

(Continued)



Table 1. (Continued)

Enzyme <sup>a</sup>	$k'_A$ ( $M^{-1}s^{-1}$ )	$k'_B$ ( $M^{-1}s^{-1}$ )	$k_{cat}$ ( $s^{-1}$ )	$K_{M,ROOH}$ ( $\mu M$ )	$K_{M,red}$ ( $\mu M$ )	Ref.
Mouse Prx III	$> 2.4 \times 10^{5d}, s$ $> 2.4 \times 10^{5e}, s$	$1.1 \times 10^{6s}$	4.8 <sup>r</sup>	$< 20^d$ $< 20^e$	4.3 <sup>o</sup>	(Chae <i>et al.</i> 1999)
Human Prx V	ND	ND	ND	$< 20^d$	1 <sup>i</sup>	(Seo <i>et al.</i> 2000)

<sup>a</sup> In all cases with the exception of C/TXNPrx, kinetic parameters were reported for recombinant proteins.

<sup>b</sup> In these cases, values obtained from Dalziel plots were 0, indicating that real maximum velocities of the reaction could neither be measured nor extrapolated,  $k_{cat}$  being the reciprocal value of  $\Phi_0$ , is therefore infinite.

The oxidizing substrate used were <sup>c</sup> *tert*-butyl hydroperoxide, <sup>d</sup>  $H_2O_2$ , <sup>e</sup> cumene hydroperoxide, <sup>u</sup> phosphatidylcholine hydroperoxide, <sup>w</sup> linoleic acid hydroperoxide.

The reducing substrate utilized were the recombinant His-tagged proteins <sup>f</sup> *C. fasciculata* tryparedoxin I, <sup>g</sup> *C. fasciculata* tryparedoxin 2, <sup>h</sup> *T. brucei* tryparedoxin, <sup>i</sup> *M. tuberculosis* thioredoxin B, <sup>j</sup> *M. tuberculosis* thioredoxin C, <sup>k</sup> *M. tuberculosis* alkyl hydroperoxide reductase (Ahp) D, <sup>l</sup> homologous thioredoxin, <sup>m</sup> S128W N-terminal domain of AhpF, <sup>n</sup> heterologous *E. coli* thioredoxin, <sup>o</sup> rat thioredoxin, <sup>v</sup> DTT (500  $\mu M$ )

<sup>p</sup> This enzyme is subject of substrate inhibition, resulting from a dead-end interaction of the substrate with a non-productive form of the enzyme, so reported kinetic constants are apparent values.

<sup>q</sup> apparent values at non saturating reductant concentration.

<sup>r</sup>  $k_{cat}$  values were calculated from specific activities and protein molecular weights reported in (Chae *et al.*, 1999)

<sup>s</sup> in this cases,  $k'_A$  and  $k'_B$  values were calculated as  $k_{cat}/K_m$  for the oxidizing and reducing substrate, respectively.

<sup>t</sup> Data utilizing P/Trx I as reducing substrate are also available, but catalytic efficiency is lower than with P/Trx 2.

mutation  $k_{+5}$  (Fig. 1) is slowed down sufficiently to enable full active site occupancy of  $E_{ox2}$  with tryparedoxin and, in consequence, the kinetic pattern now corresponds to Michaelis-Menten type saturation kinetics.

If the substrate-independent term  $\Phi_0$  is not zero, a rate constant describing a reaction within a complex is rate limiting, as in typical Michaelis-Menten kinetics.  $\Phi_1$  is the reciprocal value for the catalytic efficiency towards the oxidizing substrate ( $k_{cat}/K_M^A$ ) which, assuming that  $k_{-1}$  value is low compared to other kinetic constants of the oxidizing part of the catalytic cycle, again approaches  $k_{+1}$  (compare Eqs. 4 and 7), i. e. the second order rate constant for the reaction between the reduced enzyme and the oxidizing substrate, which also can be directly measured by pre-steady state approaches (see below).  $\Phi_2$  is the reciprocal value for the catalytic efficiency ( $k_{cat}/K_M^B$ ) towards the reducing substrate, and in case that the rate constant for the dissociation of the complex between the oxidized enzyme and the reducing substrate ( $k_{-4}$ ) is small compared to the rate constants for the following steps in the reductive part of the catalytic cycle, again approaches  $k_{+4}$  (see Eqs. 5 and 7), the second order rate constant for the reaction between the oxidized enzyme and the reducing substrate. The terms  $k'_A$  and  $k'_B$  (reciprocal values of  $\Phi_1$  and  $\Phi_2$ , respectively) have been frequently utilized to name the apparent net forward rate constants for the overall oxidizing and reductive part of catalytic cycle, respectively. These apparent rate constants are particularly helpful to estimate the speed of hydroperoxide removal and the rate of regeneration of reduced enzyme at substrate concentrations prevailing under *in vivo* conditions.

Reported  $k_{cat}$ ,  $k'_A$ ,  $k'_B$  and  $K_M$  values for different peroxiredoxins are listed in Table 1. The results are selected from the literature for maximum relevance as judged by choice of physiological substrates and suitability of experimental design. In the case of *Salmonella typhimurium* AhpC, a mutated form of a truncated AhpF, which is the natural reductant of this AhpC, bearing an additional Trp residue adjacent to the redox-active disulfide so as to resemble the active site of thioredoxin, was utilized for kinetic determinations (Parsonage *et al.*, 2005). The catalytic efficiency for this enzyme with  $H_2O_2$  as oxidizing substrate, measured as the relationship  $k_{cat}/K_M(H_2O_2)$ , was in the  $10^7 M^{-1}s^{-1}$  range. This data, together with recent reports in a 2-Cys Prx of *Toxoplasma gondii* (Akerman *et al.*, 2005), *Escherichia coli* thiol peroxidase (Baker *et al.* 2003), *Trypanosoma brucei* cTXNPx (Budde *et al.*, 2003), which also displayed high catalytic efficiencies towards hydroperoxide substrates, indicate that at least some peroxiredoxins are efficient peroxidases even when compared to heme peroxidases and selenium-containing glutathione peroxidases ( $k'_1 \sim 10^7 M^{-1}s^{-1}$  and  $\sim 10^8 M^{-1}s^{-1}$ , respectively) (Flohé *et al.*, 2001), specially if the high concentrations of Prxs in many cell types are considered (Wood *et al.*, 2003).

Figure 3 shows an example of a Dalziel analysis of a peroxiredoxin, thioredoxin peroxidase of *Mycobacterium tuberculosis* (MtTPx), which is an atypical 2-Cys Prx. The primary Dalziel plots presented are meant to introduce just one of the problems one has to face when dealing with Prx kinetics. In Fig. 3A the reciprocal initial rates plotted against the reciprocal concentrations of the oxidizing substrate yielded straight lines which, as expected, were parallel for different concentrations of the

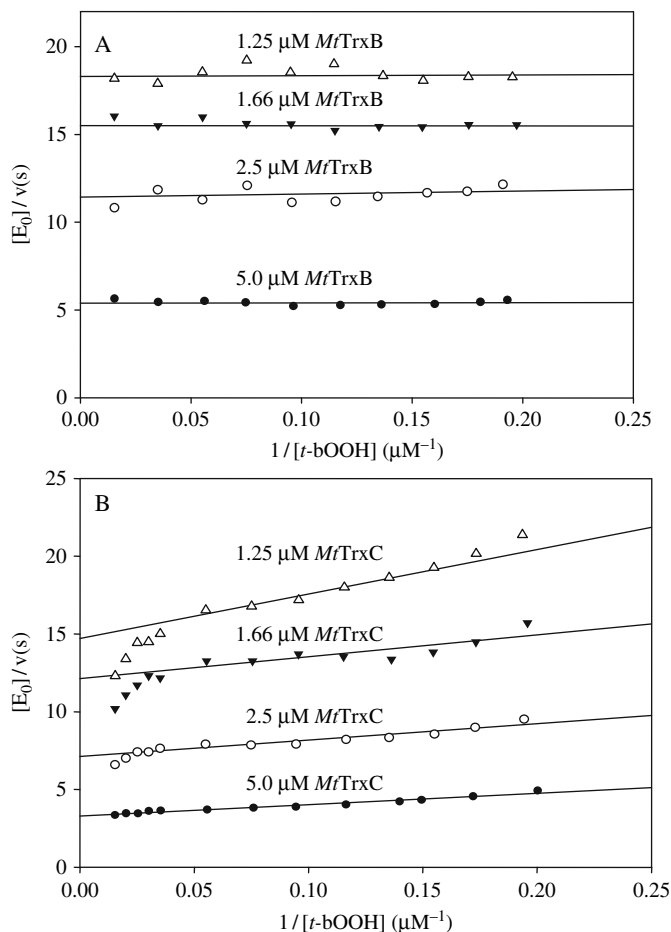

Figure 3. Examples of primary Dalziel plots obtained with the same peroxidoredoxin measured with different donor substrates. A, *MfTrPx* reacted with *MfTrxB* as reductant. B, *MfTrPx* under identical conditions, but with *MfTrxC* as reductant. For comments see text. (Taken from Jaeger *et al.*, 2004 with permission)

reducing substrate (thioredoxin B) that was kept constant by continuous regeneration at the expense of NADPH via thioredoxin reductase, i.e. in a coupled assay. When the ordinate intercepts ( $[E]/V_{\max} \text{app}$ ) were re-plotted against  $1/[B]$  (not shown), a  $\Phi_0$  clearly distinct from zero was obtained, thus revealing that the pattern, unlike that of *CfTXNPx*, corresponded to Eq. 3, i.e. an enzyme substitution mechanism with saturation kinetics, which appears to be the most abundant kinetic pattern of peroxidoredoxins (see Table 1).

The primary plot shown in Fig. 3B was obtained with the very same enzyme, the same assay and experimental conditions, the same range of substrate concentrations,

but with a different reductant, the mycobacterial thioredoxin C. Clearly, the exchange of one physiological for another homologous thioredoxin results in a kinetic pattern that seems not to comply with an enzyme substitution mechanism: The lines corresponding to the lower co-substrate concentrations are no longer parallel, suggesting a central complex mechanism, while the ones for higher co-substrate concentrations are parallel, which complies with the expected enzyme substitution mechanism. Further, the lines are no longer straight; they steeply decline when approaching the y axis. However, a detailed investigation of *MtTPx* by means of stopped-flow analysis of partial reactions (see below) and mass spectroscopic identification of catalytic intermediates provided independent compelling evidence that the catalytic mechanism in essence is an enzyme substitution mechanism and essentially the same for both types of thioredoxins (Trujillo *et al.*, 2006).

The molecular basis of the irregularity still remains a matter of speculation. Budde *et al.* (Budde *et al.*, 2003) described the phenomenon, in terms of the Changeux-Monod model, as indicating a negative cooperativity between the subunits of the oligomeric enzyme (in this case of TXNPx from *Trypanosoma brucei*), since it changed its quaternary structure in a redox-dependent manner, as has been reported for many Prxs (see Chapter 3). However, for an enzyme in charge of antioxidant defense such as a TXNPx a negative cooperativity, which implies lower efficiency under conditions of increased demand, does not make much sense, and one should not ignore the possibility that the irregular kinetic patterns simply reflect a certain weakness inherent in the character of catalysis. Not by chance was the phenomenon first reported for the mitochondrial form of TXNPx from *Leishmania infantum* (*LimTXNPx*) (Castro *et al.*, 2002). This enzyme, depending on the nature and concentration of the hydroperoxide used, proved to be oxidatively inactivated already during the few minutes required for conventional activity determination, and it is obvious that inactive or less active enzyme forms might have accumulated also during the steady state kinetic measurements and thus have falsified the concentration of fully active enzyme. Oxidative inactivation as such is a problem common to all peroxiredoxins and, with some mammalian Prxs, is already observed at very low concentrations of hydroperoxides ( $<1 \mu\text{M H}_2\text{O}_2$ ) (Yang *et al.*, 2002). In most cases the observed inhibitory effect of the oxidizing substrate on Prxs was reported to be irreversible. The inactivation is now primarily ascribed to over-oxidation of the peroxidatic cysteine to a sulfinic acid. Excess hydroperoxide competes with  $C_R$  for the reaction of  $C_P$ , when pre-oxidized to the sulfenic acid form, and the rate of inactivation will therefore depend on the rate constant  $k_{+3}$  (Fig. 1) in relation to that of the competing reaction of  $E_{ox1}$  with an ROOH, as well as on the concentrations of the reactants. This interpretation would also comply with the most surprising discrepancy between the data sets shown in Fig. 3. *MtTrxB*, being a more efficient reductant for *MtTPx* than *MtTrxC* ( $K_M$  for TrxB  $\ll$  than  $K_M$  for TrxC; Table 1), would be in a better position to keep the peroxidase preferentially in the reduced state and thereby to prevent the  $[E_{ox1}]$ -dependent inactivation and concomitant kinetic irregularities. In case of *MtTPx*, however, additional modes of oxidative alterations have to be considered. *MtTPx* is an atypical 2-Cys Prx that

does not require its  $C_R$  to sustain the entire catalytic cycle but nevertheless can form a disulfide bridge between  $C_P$  and  $C_R$  which can be reduced by thioredoxins. Also, a disulfide bridge between  $C_P$  and a non-conserved catalytically irrelevant cysteine could be detected in an enzyme preparation that was oxidized by slightly overstoichiometric ROOH concentrations in the absence of reductant (Trujillo *et al.*, 2006). Certainly, these different forms of oxidized enzyme will not react identically with each of the physiological reductants. If or to what extent all these different enzyme forms also induce conformational changes with associated alterations of catalytic efficiencies in the context of the oligomeric assemblies as proposed by Budde *et al.* (2003), is not easily answered by accessible experimental tools. In short, there are plenty of possibilities to explain deviations from an expected kinetic pattern and, taking together kinetic and chemical evidences, an enzyme substitution mechanism identical or similar to that depicted in Fig. 1 is still the most appropriate concept to describe peroxiredoxin catalysis.

To some extent overoxidation of  $C_P$  appears to occur even during catalysis *in vivo*. A kinetic analysis of mammalian Prx I inactivation in the presence of a low steady-state level  $H_2O_2$  ( $< 1 \mu M$ ) indicated that Prx I was over-oxidized at a rate of 0.072 % per turnover at 30 °C (Yang *et al.*, 2002). Susceptibility to over-oxidation in 2-Cys Prxs is related to a structural motif, *i e.* the C-terminal GCLG tail, present in eukaryotic but not in prokaryotic enzymes.<sup>3</sup> The motif is supposed to slow down the reaction between the sulfenic acid derivative of  $C_P$  with  $C_R$ , thus giving time for the over-oxidation of the sulfenic acid by a second molecule of oxidizing substrate (Wood *et al.*, 2003). This inactivation process cannot be generally considered a weakness of Prx catalysis. It might well be that nature has taken advantage of this possibility to switch off the enzymes in special situations. The appealing hypothesis arose that the C-terminal tail in eukaryotic Prxs is an adaptation allowing them to function as floodgates, keeping resting levels of hydrogen peroxide low, while permitting higher levels for signal transduction (Wood *et al.*, 2003). The description of sulfiredoxins (Biteau *et al.*, 2003; Chang *et al.*, 2004) and sestrins (Budanov *et al.*, 2004), enzymes responsible for sulfinic acid reduction in typical two-cysteine Prxs (Woo *et al.*, 2005) to recover the enzymatic activity, lends further support to the physiological relevance of the inactivation process. The presence of enzymes that specifically facilitate the redox cycling between the thiol and the sulfinic acid forms of peroxiredoxins might represent an important switch by which the activity of these proteins can be adapted to oxidative challenge.

In addition to the coupled assay, steady state kinetic determinations in peroxiredoxins have also been performed by taking advantage of the decrease in the intensity of thioredoxin fluorescence that occurs upon oxidation (Holmgren, 1972). Figure 4, inset, shows the changes in the emission fluorescence spectra that take

---

<sup>3</sup> Thus, prokaryotic Prxs, as well as other Prxs devoid of C-terminal tail, are less sensitive to oxidative inactivation. Accordingly, prokaryotes do not contain sulfiredoxin (Biteau, *et al.*, 2003; see also Chapters 3, 4 and 9).

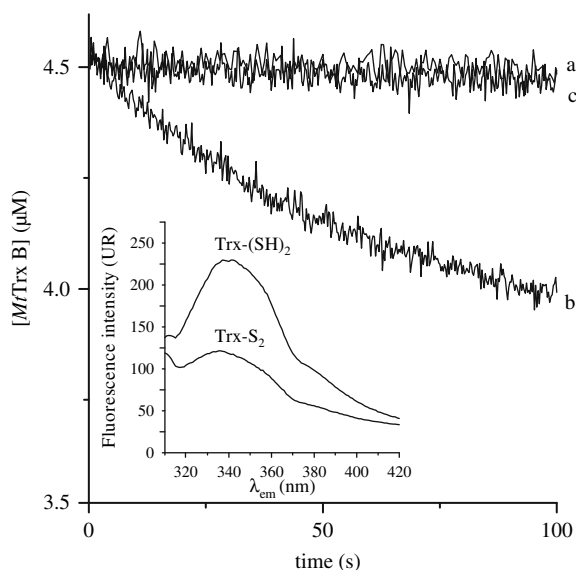

Figure 4. *Mt* TPx activity measured by changes in *Mt* TrxB fluorescence in the presence of  $\text{H}_2\text{O}_2$ . Pre-reduced *Mt*TrxB ( $4.5 \mu\text{M}$ ) was mixed with  $\text{H}_2\text{O}_2$  ( $1.6 \mu\text{M}$ ) in phosphate buffer  $50 \text{ mM}$   $\text{pH}$   $7.4$  and  $25^\circ\text{C}$ , either with no further addition (a), or in the presence of  $0.7 \mu\text{M}$  wild type *Mt*TPx (b) or  $0.7 \mu\text{M}$  C60S *Mt*TPx (c) and changes in fluorescence intensity ( $\lambda_{\text{ex}} = 280 \text{ nm}$ ,  $\lambda_{\text{em}} > 335 \text{ nm}$ ) were registered by stopped-flow techniques. Initial rates of *Mt*TrxB reduction by wild-type *Mt*TPx were calculated from the initial slope of fluorescence intensity change and a calibration curve relating fluorescence changes with reduced *Mt*TrxB concentration. The inset shows the emission spectrum ( $\lambda_{\text{ex}} = 280 \text{ nm}$ ) of *Mt*TrxB ( $2.5 \mu\text{M}$ ) before ( $\text{Trx-S}_2$ ) and 1 minute after the addition of  $1 \text{ mM}$  DTT ( $\text{Trx-SH}_2$ )

place upon *Mycobacterium tuberculosis* thioredoxin B reduction by DTT. Wild type *M. tuberculosis* TPx (Fig. 4, line b) but not the C60S TPx (Fig. 4, line c), in which the critical peroxidatic cysteine residue has been mutated to serine, catalyzed  $\text{H}_2\text{O}_2$ -dependent *M. tuberculosis* thioredoxin B oxidation (Fig. 4). A similar fluorescence method was used for kinetic studies on *S. typhimurium* AhpC (Parsonage *et al.*, 2005).

## 2.2. Pre-steady State Approaches

If an appropriate read out and sufficient quantities of enzyme are available, some of the rate constants involved in Prxs catalysis can be directly measured by stopped-flow techniques. Results thus obtained are less ambiguous and may therefore be considered decisive, if the interpretation of steady state data is not entirely clear. In the analysis of peroxidase kinetics, the pre-steady state approach has also the advantage of being less time-consuming; in consequence, problems resulting from enzyme alteration due to long-term exposure to the aggressive substrates are minimized. A particular problem has, however, to be considered: If a catalytic

intermediate, *e.g.* oxidized enzyme, is used as starting material for further analysis, one can hardly be sure that the intermediate prepared *in vitro* exactly corresponds to the real catalytic one.

### 2.2.1. Rate constant determinations for the reactions between reduced enzyme and hydroperoxide substrates

The reaction between reduced *S. cerevisiae* thioredoxin peroxidase I and  $\text{H}_2\text{O}_2$  has been determined by Augusto and coworkers by a competition approach utilizing the well known reactivity of  $\text{H}_2\text{O}_2$  with horseradish peroxidase (HRP)(Ogusucu *et al.*, in press).  $\text{H}_2\text{O}_2$ -mediated HRP oxidation is a two-electron oxidation process, leading to the formation of Compound I, which can be spectroscopically followed at 403 nm. The addition of increasing concentrations of pre-reduced *S. cerevisiae* thioredoxin peroxidase I (TPx I) or II (TPx II), led to a lower yield in Compound I formation, and from the rate constant for Compound I formation in the absence of peroxiredoxin and the concentrations of HRP and *S. cerevisiae* TPx I or TPx II, the second order rate constants for the reactions between the yeast Prxs and  $\text{H}_2\text{O}_2$  could be calculated. With values in the  $10^7 \text{ M}^{-1}\text{s}^{-1}$  range (Ogusucu *et al.*, 2007), the  $k_{+1}$  turned out to be much faster than the values previously reported for the catalytic efficiency ( $k_{\text{cat}}/K_{\text{M}}\text{H}_2\text{O}_2$ ) of *S. cerevisiae* TPx I and TPx II obtained by a more indirect coupled-system steady state approach (Munhoz *et al.* 2004). With the same method<sup>4</sup> the rate constant for the reaction between reduced cytosolic TXNPx of *Trypanosoma brucei* and  $\text{H}_2\text{O}_2$  was determined (Fig. 5). The rate constant thus obtained was  $4.9 \pm 1 \times 10^6 \text{ M}^{-1}\text{s}^{-1}$ , which complies reasonably with the  $k_{+1}$  of  $1.7 \times 10^7 \text{ M}^{-1}\text{s}^{-1}$  obtained by steady state analysis for the reaction of *Tb*TXNPx with t-butyl hydroperoxide (Budde *et al.*, 2003).

### 2.2.2. Rate constant determination for the reaction between oxidized enzyme and reducing substrates

The rate constant for the reduction of oxidized peroxiredoxin by thioredoxin or related proteins can be determined fluorimetrically by stopped-flow techniques, taking advantage of the fluorescent properties of a tryptophan residue near the active site that differs between the reduced or oxidized state of thioredoxin (Holmgren, 1972). This method was used to determine the kinetics of wild type, C60S- and C93S-mutated forms of *Mt*TPx reduction by *Mt*Trx B. Expectedly the mutant lacking  $\text{C}_p$  (*Mt*TPx C60S) was inactive. For the wild type enzyme, an overall rate constant for this reductive part of the catalytic cycle ( $k'_B$ ) of  $8.2 \times 10^3 \text{ M}^{-1}\text{s}^{-1}$  was obtained (Trujillo *et al.*, 2006), which is lower by a factor of 5 than the corresponding value deduced from steady state kinetics (Jaeger *et al.*, 2004).

<sup>4</sup> With a small variation; HRP oxidation was followed at 397.5 nm, (the isosbestic point between Compound I and Compound II HRP) in order to avoid interferences arising from Compound I reduction to Compound II which could be accelerated by the presence of reduced Prx.

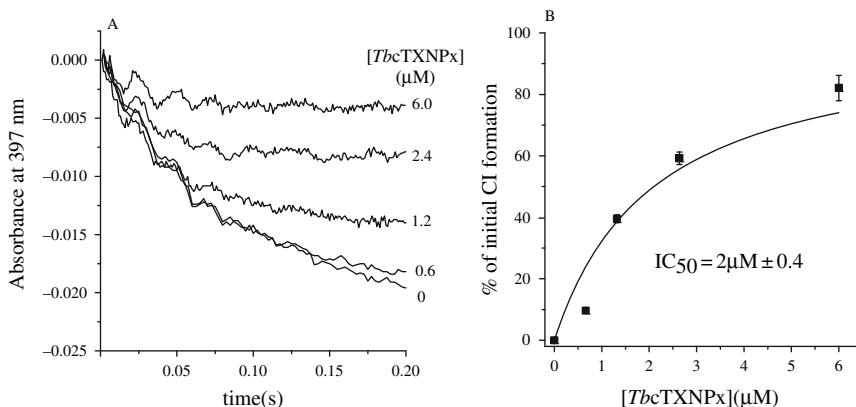

**Figure 5.** Competition kinetics for determining the rate constant of hydrogen peroxide-dependent *Tb cTXNPx* oxidation. A) Horseradish peroxidase (2 μM) was exposed to H<sub>2</sub>O<sub>2</sub> (0.25 μM) in sodium phosphate buffer pH 7.4 and 25 °C, either in the absence or in the presence of the indicated concentrations of reduced *TbcTXNPx*. Changes in absorbance at 397.5 nm, reflecting Compound I formation were determined. B) The absorbance changes shown were fitted to exponential decays, and amplitudes of the exponential decay were determined. Percentages of initial Compound I formation were calculated as: 100 – (Amplitude of exponential decay in the presence of indicated concentration of *TbcTXNPx*/Amplitude of exponential decay in the absence of *TbcTXNPx* × 100)

The discrepancy likely results from the fact that in the stopped-flow experiment the oxidized *MtTPx*, as shown by chemical analysis, was the disulfide form that is not necessarily the usual catalytic intermediate that is to be reduced by thioredoxin. For a molecular mutant lacking the presumed C<sub>R</sub> (*MtTPx* C93S) a slightly higher rate constant ( $1.1 \times 10^4 \text{ M}^{-1}\text{s}^{-1}$ ) was obtained, although the activity of this oxidized enzyme form was likely compromised by over-oxidation of its C<sub>P</sub>. This mutant protein had been found to be completely inactivated within a minute under conditions of conventional activity determination but proved to be fully active within the limited time scale of the stopped-flow experiment as well as during decomposition of low steady state levels of oxidants generated as fluxes. Taken together, the findings allow three conclusions that might be relevant to the catalysis of peroxiredoxins in general and in particular to that of atypical 2-Cys Prxs (Trujillo *et al.*, 2006): *i*) For *MtTPx* and possibly for some other atypical 2-Cys Prxs  $E_{ox1}$  is the regular catalytic intermediate that is preferentially attacked at its C<sub>P</sub> by the thioredoxin. *ii*) The conserved distal cysteine (here C93), which had been postulated to be the equivalent of C<sub>R</sub> in bacterial atypical 2-Cys Prxs (Baker *et al.*, 2003), is not obligatorily involved in catalysis, but it can form a disulfide bridge with C<sub>P</sub>; this disulfide form ( $E_{ox2}$ ) represents an alternative catalytic intermediate from which the ground state enzyme can be regenerated by thioredoxins with a slightly lower rate constant  $k'_B$ . *iii*) In *MtTPx* the presumed C<sub>R</sub> has adopted the primary function to prevent over-oxidation of C<sub>P</sub> by reversibly storing the oxidation equivalents of the unstable sulfenic acid form as less unstable disulfide when the enzyme runs short in reducing substrate.



### 3. THE SPECIAL CASE: PEROXYNITRITE

In 2000, Bryk *et al.* demonstrated for the first time that a bacterial peroxiredoxin, alkyl hydroperoxide reductase C (AhpC) could not only detoxify hydroperoxides, but also had peroxynitrite reductase activity. This was later confirmed for several bacterial, parasitic and mammalian Prxs (Bryk *et al.*, 2000; Dubuisson *et al.*, 2004; Jaeger *et al.*, 2004; Trujillo *et al.*, 2004).

#### 3.1. Biochemistry of Peroxynitrite

Peroxynitrite<sup>5</sup> is a powerful oxidant formed from the diffusion-limited reaction between superoxide anion ( $O_2^{\bullet-}$ ) and nitric oxide ( $\bullet NO$ ) radicals *in vivo* [ $k = 1.9 \times 10^{10} M^{-1}s^{-1}$  (Nausser *et al.*, 2002)], which contributes to pathogenicity in a variety of disease states such as hyperglycemic vascular damage (Cowell *et al.*, 2004; Pacher *et al.*, 2005), hypertension (Belik *et al.*, 2004; Oishi *et al.*, 2006), neurodegenerative processes (Souza *et al.*, 2000; Beckman *et al.*, 2001) and inflammatory disorders (McCafferty, 2000; Szabo, 2003), but is also involved in the cellular immune responses against invading pathogens (Linares *et al.*, 2001; Naviliat *et al.*, 2005). Both peroxynitrite anion and its conjugated acid, peroxynitrous acid ( $pK_a = 6.8$ ) (Beckman *et al.*, 1990; Radi *et al.*, 1991), are oxidizing species which can directly perform one or two electron oxidations of different biologically relevant targets, including thiol-containing compounds, carbon dioxide and metalloproteins (Radi *et al.*, 2000). Even in the absence of a reaction partner, peroxynitrous acid is unstable and decays to nitrate ( $NO_3^-$ ), by a homolytic route, with the formation of hydroxyl radical ( $\bullet OH$ ) and nitrogen dioxide ( $\bullet NO_2$ ) in 30 % yields (Gerasimov *et al.*, 1999; Hodges *et al.*, 1999). Therefore, peroxynitrite-mediated oxidations can also be indirect, i.e. mediated by peroxynitrite-derived radicals. Direct or indirect oxidations mediated by peroxynitrite can be experimentally distinguished, since in the former case the addition of increasing concentrations of the target leads to a correspondingly increasing rate of peroxynitrite decay, whereas in the latter, peroxynitrite decomposition is not accelerated by the target (Alvarez *et al.*, 1999; Radi, 2004).

Peroxynitrite can oxidize thiol-containing compounds (Radi *et al.*, 1991) either by direct or indirect mechanisms (Radi *et al.*, 2000). Direct thiol oxidation by peroxynitrite is a two-electron reaction leading to the formation of nitrite and the corresponding sulfenic acid derivative, which can react with another thiol to produce a disulfide. The overall stoichiometry of the reaction is two thiols oxidized by peroxynitrite (Radi *et al.*, 1991; Trujillo *et al.*, 2002).

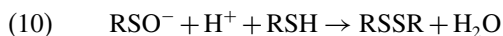

<sup>5</sup> IUPAC recommended name for peroxynitrite anion ( $ONOO^-$ ) and peroxynitrous acid ( $ONOOH$ ) ( $pK_a = 6.8$ ) are oxoperoxonitrate ( $1^-$ ) and hydrogen oxoperoxonitrate, respectively. The term peroxynitrite is used to refer to the sum of  $ONOO^-$  and  $ONOOH$ .

The pH profiles for the apparent second order rate constants for the reaction between peroxynitrite and thiols are bell-shaped (Radi *et al.*, 1991), which can be alternatively explained by the reaction occurring either between peroxynitrous acid (ONOOH) and the thiolate anion ( $\text{RS}^-$ ) or between peroxynitrite anion ( $\text{ONOO}^-$ ) and the protonated form of the thiol (RSH). However, when comparing the pH profiles for peroxynitrite reactivities of various low molecular weight thiols, those with the lower  $\text{pK}_a$  show increased reactivity with peroxynitrite at pH 7.4 (Trujillo *et al.*, 2002), as is also the case for hydrogen peroxide- and chloramine-dependent thiol oxidations (Peskin *et al.*, 2001). This is consistent with a proposed mechanism of a reaction where  $\text{RS}^-$  reacts with ONOOH. The pH-independent rate constants of low molecular weight thiols towards peroxynitrite are smaller for the thiols with lower  $\text{pK}_a$ , as was previously reported for thiol disulfide exchange reactions (Szajewski *et al.*, 1980), consistent with the fact that the thiols with the lower  $\text{pK}_a$  have also a lower nucleophilicity. Peroxynitrite-derived radicals can also oxidize thiols but by a one electron oxidation mechanism that leads to the formation of thiyl radical derivatives, which can be detected by EPR techniques (Bonini *et al.*, 2001; Quijano *et al.*, 2001). Since these radicals are formed in 30–35% yields with respect to peroxynitrite concentration, the stoichiometry of the reaction in this case is lower ( $< 1$  thiol oxidized/peroxynitrite), although it can increase due to secondary oxygen-dependent chain reactions (Quijano *et al.*, 2001).

The peroxynitrite reductase activity has meanwhile been established for typical 2-cysteine Prxs comprising various bacterial AhpCs, trypanosomal tryparedoxin peroxidases (Bryk *et al.*, 2000; Trujillo *et al.*, 2004) and thioredoxin peroxidase 1 of *Plasmodium falciparum*, for atypical 2-cysteine Prxs such as MtTPx (Jaeger *et al.*, 2004; Trujillo *et al.*, 2006), human PrxV (Dubuisson *et al.*, 2004) and for mammalian Prx VI, which is a 1-cysteine Prx (Peshenko *et al.*, 2001), and thus appears common to the entire Prx family. Cellular studies in yeast (Wong *et al.*, 2002) and *Leishmania chagasi* (Barr *et al.*, 2003) revealed the importance of Prxs for peroxynitrite detoxification *in vivo*. The kinetics of peroxynitrite reduction by peroxiredoxins can be studied either by transient or by steady state approaches. However, due to the short half life of peroxynitrite ( $t_{1/2} < 1$  s at pH 7.4 and 37 °C), investigations of peroxynitrite reactivity usually rely on rapid kinetic techniques.

### 3.2. Pre-steady State Kinetics: Determining the Kinetics of Peroxynitrite-mediated Peroxiredoxin Oxidation, Direct Initial Rate and Competition Approaches

*Direct approach:* The second order rate constant for the reaction between peroxynitrite and reduced peroxiredoxins can be determined directly, by following the effect of increasing concentrations of pre-reduced Prx on initial rate of peroxynitrite decay in a stopped-flow spectrophotometer (Fig. 6). With this approach, the pH-dependent second order rate constant for the reaction between reduced AhpC from *Salmonella typhimurium*, *Mycobacterium tuberculosis* and *Helicobacter pylori*,

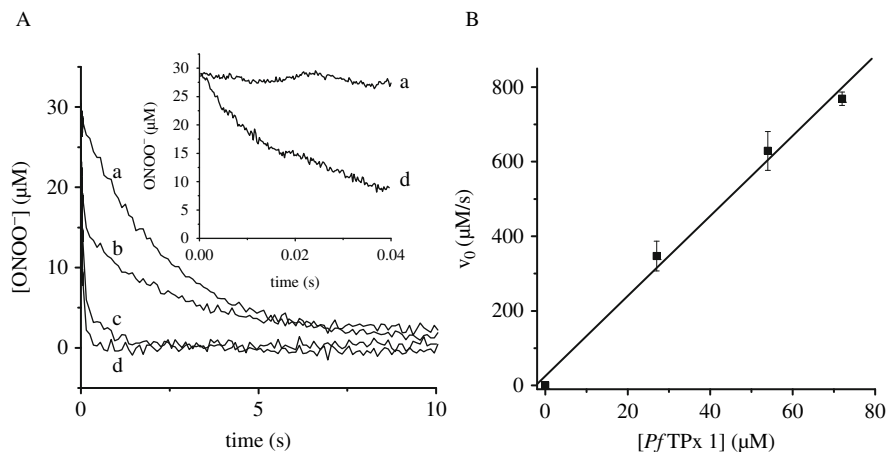

**Figure 6.** Determining the kinetics of the reaction between peroxynitrite and *Pf*TPx1 by a direct pre-steady state approach. (A) Peroxynitrite (28 μM) decomposition in potassium phosphate buffer 50 mM pH 7.4, 25°C, plus 0.1 mM dtpa, either without further addition (a), or in the presence of increasing concentrations of reduced *Plasmodium falciparum* thioredoxin peroxidase 1 (*Pf*TPx 1) (b = 27 μM, c = 54 μM, d = 72 μM) was followed at 310 nm in a stopped flow spectrofluorimeter. In order to improve the resolution of initial rate determinations, 200 data points were acquired during the first 50 ms of the reactions and other 200 data point during the rest of the time course of the reaction. The inset shows a larger view of the first 40 ms of reaction for the conditions indicated in (a) and (d). (B) Initial rates of peroxynitrite decomposition shown in A (first 20 ms of the reaction) were plotted against *Pf*TPx 1 concentration. From the slope of this plot, divided by the concentration of peroxynitrite utilized in the experiments (28 μM) a rate constant of  $4 \times 10^5 \text{ M}^{-1}\text{s}^{-1}$  for the reaction between peroxynitrite and reduced *Pf*TPx 1 at pH 7.4 and 25°C was calculated, in reasonable agreement with the value of  $1 \times 10^6 \text{ M}^{-1}\text{s}^{-1}$  that was measured for the same reaction at 37°C (Nickel *et al.*, 2005)

thioredoxin peroxidase1 of *Plasmodium falciparum*, cytosolic trypanedoxin peroxidases of *Trypanosoma brucei* and *Trypanosoma cruzi* with peroxynitrite have been determined (Table 2). Similar experiments performed with the enzymes that were mutated at the peroxidatic cysteine indicated that this residue was indeed the one that is responsible for the fast reactivity towards peroxynitrite. In contrast, enzymes that were mutated at the resolving cysteine continued reacting fast with peroxynitrite, as expected. This fast reactivity of peroxynitrite with the peroxidatic cysteine is explained, at least partially, by its low  $\text{pK}_a$  (< 5 in the case of bacterial AhpC) (Bryk *et al.* 2000), although other not yet characterized protein- related factors might also be involved. In the case of *Mt*TPx and human Prx 5, the reaction with peroxynitrite was so rapid that the initial rate approach could not be safely utilized, since an important fraction of peroxynitrite decayed during the mixing time of the stopped-flow apparatus (usually 1–2 ms). This problem was solved in different ways by different groups: either by recurring to competition or indirect approaches (Jaeger *et al.*, 2004) or by utilizing more rapid pulse radiolysis methodologies (Dubuisson *et al.*, 2004).

Table 2. Reported second order rate constants for peroxynitrite reduction by peroxiredoxins

Peroxiredoxin	Rate constant (M <sup>-1</sup> s <sup>-1</sup> )	Conditions	Reference
<i>S. typhimurium</i> AhpC	1.5 × 10 <sup>6</sup>	pH 6.8 <sup>1</sup>	(Bryk <i>et al.</i> , 2000)
<i>M. tuberculosis</i> AhpC	1.3 × 10 <sup>6</sup>	pH 6.8 <sup>1</sup>	(Bryk <i>et al.</i> , 2000)
<i>H. pylori</i> AhpC	1.2 × 10 <sup>6</sup>	pH 6.8 <sup>1</sup>	(Bryk <i>et al.</i> , 2000)
<i>T. Brucei</i> TXNPx	9.0 × 10 <sup>5</sup>	pH 7.4, 37°C	(Trujillo <i>et al.</i> , 2004)
<i>T. cruzi</i> TXNPx	7.2 × 10 <sup>5</sup>	pH 7.4, 37°C	(Trujillo <i>et al.</i> , 2004)
<i>M. tuberculosis</i> TPx	1.5 × 10 <sup>7</sup>	pH 7.4, 25°C	(Jaeger <i>et al.</i> , 2004)
Human Prx V	7.0 × 10 <sup>7</sup>	pH 7.8 <sup>1</sup>	(Dubuisson <i>et al.</i> , 2004)
<i>P. falciparum</i> TPx 1	1.0 × 10 <sup>6</sup>	pH 7.4, 37°C	(Nickel <i>et al.</i> , 2005)
<i>Sacharomyces cerevisiae</i> thioredoxin peroxidase I	7.4 × 10 <sup>5</sup>	pH 7.4, 25°C	(Ogusucu <i>et al.</i> , 2007)
<i>Sacharomyces cerevisiae</i> thioredoxin peroxidase II	5.1 × 10 <sup>5</sup>	pH 7.4, 25°C	(Ogusucu <i>et al.</i> , 2007)

<sup>1</sup> Determinations were carried out at room temperature

*Competition approaches:* The kinetics of the reaction between peroxynitrite and Prxs have also been resolved by analyzing the effect of increasing concentrations of the enzyme on another rapid and direct peroxynitrite-dependent oxidation, that of Mn<sup>III</sup> porphyrins to O = Mn<sup>IV</sup> porphyrins (Ferrer-Sueta *et al.*, 1999).

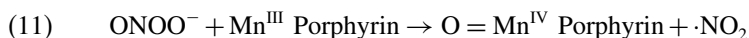

This reporter reaction has the advantages that Mn<sup>III</sup> porphyrin oxidations can conveniently be followed at the Soret band and the most adequate of a variety of Mn<sup>III</sup> porphyrins with different reactivities towards peroxynitrite can be selected for the experiments. In case of *Mt*TPx, Mn<sup>III</sup>-meso-tetrakis[(*N*-butyl)pyridinium-2-yl] porphyrin (Mn<sup>III</sup>TB-2-PyP) that reacts with peroxynitrite with a *k* of 4.8 × 10<sup>6</sup> M<sup>-1</sup>s<sup>-1</sup> at pH 7.4 and 25°C, was selected, and the effect of increasing concentrations of reduced *Mt*TPx on the yields of peroxynitrite-mediated Mn<sup>III</sup>TB-2-PyP oxidation were studied by stopped-flow techniques (Ferrer-Sueta *et al.*, 1999). As shown in Fig. 7, the percentage of inhibition of peroxynitrite-dependent Mn<sup>III</sup>TB-2-PyP oxidation by *Mt*TPx fitted to a hyperbolic function from which a concentration of reduced *Mt*TPx that half-inhibited Mn<sup>III</sup>-TB-2-PyP oxidation was determined. At that enzyme concentration, one half of the peroxynitrite reacts with Mn<sup>III</sup>TB-2-PyP and the other half with *Mt*TPx. Hence, the second order rate constant for the reaction between peroxynitrite and *Mt*TPx, *k*<sub>(*Mt*TPx)</sub>, can be calculated according to eq. 12:

$$(12) \quad \left( [\text{Mn}^{\text{III}}\text{TB-2-PyP}] - [\text{ONOO}^-] / 2 \right) \times k_{(\text{Mn}^{\text{III}}\text{TB-2-PyP})} \\ = \left( [\text{MtTPx}] - [\text{ONOO}^-] / 2 \right) \times k_{(\text{MtTPx})}$$

where *k*<sub>(Mn<sup>III</sup>-TB-2-PyP)</sub> is the second order rate constant for the reaction between peroxynitrite and the Mn<sup>III</sup> porphyrin under the same experimental conditions. By

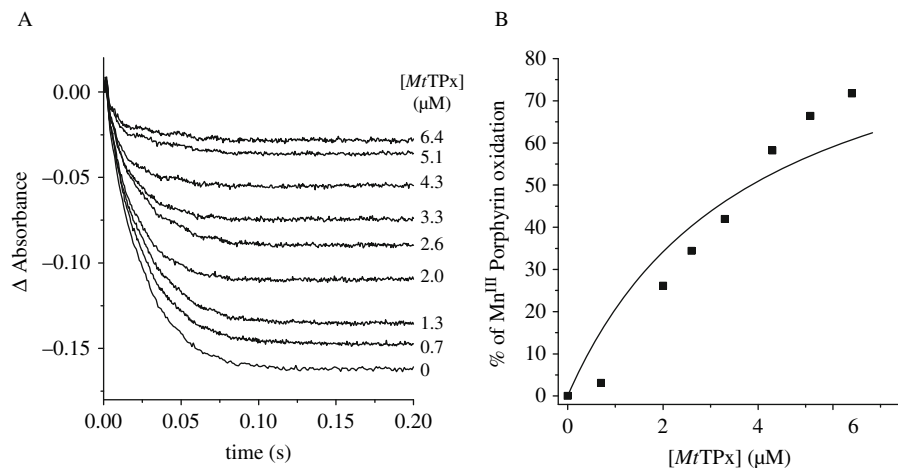

**Figure 7.** Kinetic analysis of the reaction between peroxynitrite and *MtTPx* by a competition pre-steady state approach. A)  $\text{Mn}^{\text{III}}\text{TBPpP}$  ( $7\ \mu\text{M}$ ) was exposed to peroxynitrite ( $2\ \mu\text{M}$ ) in potassium phosphate buffer  $50\ \text{mM}$ ,  $\text{pH}\ 7.35$  and  $25\ ^\circ\text{C}$ , in the presence of the indicated concentrations of *Mycobacterium tuberculosis* thioredoxin peroxidase (*MtTPx*), and changes in absorbance, corresponding to  $\text{Mn}^{\text{III}}$  porphyrin oxidation, were followed at the Soret band by stopped flow technique. B) Percentage of  $\text{Mn}^{\text{III}}\text{TBPpP}$  oxidation was calculated as  $100 - (\text{yields of } \text{Mn}^{\text{III}}\text{TBPpP} \text{ oxidation in the presence of } \text{MtTPx} / \text{yield of } \text{Mn}^{\text{III}}\text{TBPpP} \text{ oxidation in the absence of } \text{MtTPx}) \times 100$ . Fitting the data to a hyperbolic function, the concentration of *MtTPx* ( $3.8\ \mu\text{M}$ ) that half inhibited peroxynitrite-dependent  $\text{Mn}^{\text{III}}\text{TBPpP}$  oxidation was obtained

means of an independently determined  $k_{(\text{Mn}^{\text{III}}\text{TB-2-PyP})}$  of  $4.8 \times 10^6\ \text{M}^{-1}\text{s}^{-1}$  at  $\text{pH}\ 7.4$  and  $25\ ^\circ\text{C}$  [consistent with previous investigations performed at  $37\ ^\circ\text{C}$  (Ferrer-Sueta et al., 2002)] a  $k_{(\text{MtTPx})}$  of  $1.5 \pm 0.2 \times 10^7\ \text{M}^{-1}\text{s}^{-1}$  was thus obtained (Jaeger et al., 2004). Similarly, the reactivity between cytosolic TXNPx of *T. brucei* and peroxynitrite was studied. But since the reaction was slower, a  $\text{Mn}^{\text{III}}$  porphyrin with a lower reactivity towards peroxynitrite, namely, manganese (III)meso-tetrakis [(N-methyl)pyridinium-4-yl] porphyrin ( $\text{Mn}^{\text{III}}\text{TM-4-PyP}$ ) with a  $k$  of  $3.7 \times 10^6\ \text{M}^{-1}\text{s}^{-1}$  at  $\text{pH}\ 7.4$  and  $37\ ^\circ\text{C}$  was selected (Ferrer-Sueta et al., 1999). Increasing concentrations of *TbcTXNPx* caused a decrease in the yield of peroxynitrite-dependent oxidation of  $\text{Mn}^{\text{III}}\text{-TM-4-PyP}$  to  $\text{O} = \text{Mn}^{\text{IV}}\text{TM-PyP}$  and correspondingly an increase of the observed rate constant of peroxynitrite reduction by the TXNPx. From these data a real  $k$  of  $2 \times 10^6\ \text{M}^{-1}\text{s}^{-1}$  at  $\text{pH}\ 7.4$  and  $37\ ^\circ\text{C}$  was calculated, which is similar to the  $1 \times 10^6\ \text{M}^{-1}\text{s}^{-1}$  value obtained by the direct approach (Trujillo et al. 2004). A similar competitive approach determining the inhibitor effect of Prx on peroxynitrite-mediated horseradish peroxidase oxidation was utilized recently to determine the second order rate constants between two yeast peroxiredoxins and peroxynitrite (Table 2) (Ogusucu et al., 2007). As for other thiol containing compounds, the pH profile for the second order rate constant of peroxynitrite-mediated direct Prx oxidation was bell shaped, led to nitrite

formation (Bryk *et al.*, 2000) and to the oxidation of two thiol groups per peroxynitrite (Trujillo *et al.*, 2004). Moreover, the addition of sub-equimolar peroxynitrite concentrations to reduced bacterial AhpC mutated at the resolving cysteine led to the formation of a sulfenic acid derivative of the peroxidatic cysteine in the enzyme (Bryk *et al.*, 2000). This is consistent with the postulated mechanism of direct peroxynitrite-mediated two-electron oxidations of thiol containing compounds described above.

The availability of direct and indirect methods to determine the kinetics of peroxiredoxin oxidation by peroxynitrite and  $H_2O_2$ , also allows the determination of rate constants for the reaction between reduced peroxiredoxins and other oxidants, such as organic hydroperoxides, whose reduction cannot be directly followed spectrophotometrically. This method, first employed by Peshenko *et al.* (2001), determines the inhibitory effect of peroxynitrite or organic hydroperoxides on the peroxiredoxin-dependent hydrogen peroxide consumption; once the second order rate constant for peroxynitrite or hydrogen peroxide and the particular peroxiredoxin is known, the rate constants for other oxidizing substrates of interest can be calculated.

### 3.3. Steady State Approach: Peroxynitrite Reductase Activities of Peroxiredoxins

In order to reduce peroxynitrite catalytically, Prxs must not only react fast with peroxynitrite, they also have to be oxidized to the same intermediate as by hydroperoxide substrates ( $E_{ox1}$ , Fig. 1) to become regenerated by the natural reductant. A qualitative approach to demonstrate catalysis was to study whether the peroxynitrite-oxidized enzyme could be reduced back by disulfide reductants such as DTT which also reduce sulfenic acids (Dubuisson *et al.*, 2004). More compelling evidence for the formation of the presumably physiological sulfenic acid or disulfide intermediate upon peroxynitrite exposure would be the demonstration that the Prx thus oxidized is reduced to the ground state enzyme by its physiological reductant with the rate constant that is observed after oxidation by a hydroperoxide. Therefore, a model system was established that monitored the spontaneous and TXNPx-augmented oxidation of tryparedoxin by peroxynitrite in a stopped-flow equipment. Comparing the experimental traces of peroxynitrite decay with those calculated by computer-assisted simulations with predetermined rate constants unequivocally revealed that the peroxynitrite-oxidized TXNPx (of *T. brucei* and *T. cruzi*) in this system was catalytically reduced by TXN with rate constants similar to those derived from steady-state analysis (Trujillo *et al.*, 2004). In analogous experiments, the catalytic regeneration of reduced *MtTPx* from the peroxynitrite-oxidized enzyme was verified (Trujillo *et al.*, 2006).

### 3.4. Peroxiredoxins Catalytically Detoxify Peroxynitrite Formed from Fluxes of $\bullet NO$ and $O_2^-$

All experimental approaches mentioned so far require comparatively high, i. e. unphysiological, concentrations of peroxynitrite. To mimic the effect of Prxs on

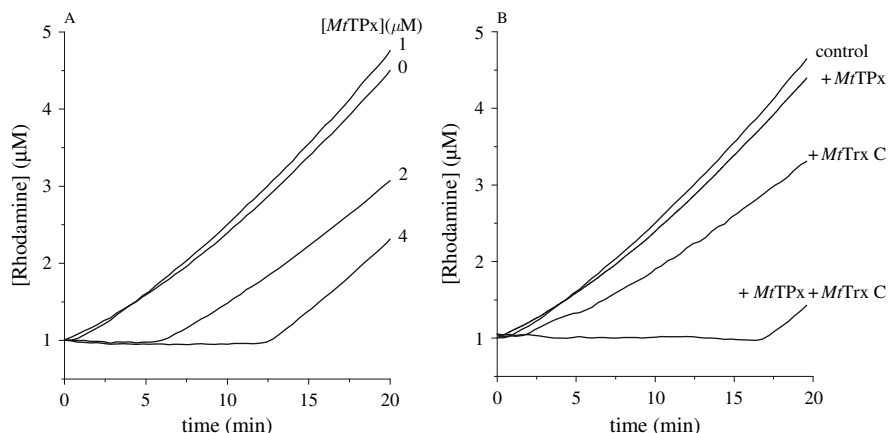

**Figure 8.** *MfTPx* catalytically detoxifies peroxynitrite formed from its radical precursors  $\cdot\text{NO}$  and  $\text{O}_2^-$ . Dihydrorhodamine ( $120\ \mu\text{M}$ ) oxidation to rhodamine by SIN-1–derived peroxynitrite in potassium phosphate buffer  $100\ \text{mM}$  pH  $7.4$   $25^\circ\text{C}$  was followed spectroscopically at  $500\ \text{nm}$ . Since DHR oxidation by fluxes of peroxynitrite has a lag phase, protein additions and all DHR oxidation registers were done once that lag phase was completed, i.e. 15 minutes before beginning the incubation of DHR with SIN-1 ( $0.2\ \text{mM}$ ). A) Effect of increasing reduced *M. tuberculosis* thioredoxin peroxidase on peroxynitrite-dependent DHR oxidation. B) Effect of  $1\ \mu\text{M}$  reduced *M. tuberculosis* thioredoxin peroxidase (*MfTPx*),  $4.6\ \mu\text{M}$  reduced *M. tuberculosis* thioredoxin C (*MfTrx C*) and  $1\ \mu\text{M}$  *MfTPx* plus  $4.6\ \mu\text{M}$  *MfTrx C* on peroxynitrite dependent DHR oxidation

physiological steady state levels of peroxynitrite, SIN-1 was used to generate a peroxynitrite flux<sup>6</sup> and the peroxynitrite-dependent oxidation of dihydrorhodamine 123 (DHR) to rhodamine 123 was monitored with and without reconstituted peroxidoredoxin systems. Although dihydrorhodamine oxidation by peroxynitrite is not a direct process but involves the peroxynitrite-derived radicals  $\cdot\text{NO}_2$  and  $\cdot\text{OH}$  (Glebska *et al.*, 2003; Wrona *et al.*, 2005), the system proved to be particularly helpful to demonstrate the efficacy of peroxidoredoxins that are prone to oxidative inactivation under conventional test procedures. Figure 8A shows the effect of pre-reduced *Mycobacterium tuberculosis* thioredoxin peroxidase (*MfTPx*) on peroxynitrite-dependent DHR oxidation. Increasing concentrations of the enzyme caused a dose-dependent increase in the lag phase prior DHR oxidation, which is equivalent to the time required for enzyme oxidation by peroxynitrite at the given flux. Once the enzyme was consumed, DHR oxidation started at the same rate than in the absence of enzyme. Almost identical results were obtained with the molecular mutant C93S which is oxidatively inactivated in less than a minute in the presence of micromolar hydrogen peroxide concentrations. This experimental approach is also

<sup>6</sup> In these experiments peroxynitrite was generated from SIN-1, which in aerobic simple biochemical systems decomposes yielding similar fluxes of  $\cdot\text{NO}$  and  $\text{O}_2^-$  that rapidly reacts to form peroxynitrite (Bohn and Schonafinger, 1989).

suites to corroborate a catalytic reduction of peroxynitrite under conditions that are close to the physiological situation. As demonstrated in Fig. 8B, 1  $\mu\text{M}$  *MtTPx* had a minimal effect on peroxynitrite-dependent DHR oxidation on its own, since it is rapidly oxidized at the given peroxynitrite flux. However, when combined with pre-reduced *M. tuberculosis* thioredoxin C (4.6  $\mu\text{M}$ ), which by itself only marginally affected DHR oxidation, *MtTPx* increased the lag phase up to 16 min, a time that was estimated to suffice for the complete oxidation of the thioredoxin (Alvarez *et al.* 2002). Thus, *MtTPx*, when oxidized by near physiological peroxynitrite fluxes, depends on efficient regeneration by a thioredoxin.

#### 4. RELEVANCE OF PEROXIREDOXIN-CATALYZED PEROXYNITRITE DETOXIFICATION

Peroxynitrite's relevance in biochemistry was first noted by Beckman *et al.* (1990) and Radi *et al.* (1991) and during the next ten years evidence of the formation of this oxidant *in vivo* accumulated. Initially considered a toxic species, peroxynitrite, like  $\text{H}_2\text{O}_2$  (Rhee, 2006), has recently started to be regarded as potentially involved in redox signaling pathways (Bachschmid, *et al.*, 2005; Touyz, 2005). By 2000, the mechanisms that control peroxynitrite toxicity and possible signaling functions remained unclear: It was known that the reaction with carbon dioxide represented one important pathway of decay, but this reaction represented only a diversion of reactivity from peroxynitrite to carbonate radical ( $\text{CO}_3^{\cdot-}$ ), which also is an oxidizing species, and therefore cannot be regarded as a true detoxification pathway. Analogous considerations applied for the fast reactions between peroxynitrite and some heme proteins (Table 3), except for the case of oxyhemoglobin that isomerizes peroxynitrite to nitrate. Similarly, the selenium-containing glutathione peroxidase 1 (GPx1) was reported to react fast with peroxynitrite (Briviba *et al.*, 1998); but surprisingly GPx1 *-/-* cells proved to be more resistant to a peroxynitrite challenge than wild-type controls (Fu *et al.*, 2001). Finally, the main biologically relevant low molecular weight reductants, such as glutathione, ascorbate, and uric acid that are capable to scavenge peroxynitrite react slowly and are often limited to a cell type or compartment.

For long peroxynitrite thus remained an important biological oxidant without an obvious widespread detoxification system, which led a number of laboratories to design and characterize synthetic peroxynitrite reductants (Lee *et al.*, 1997; Sies *et al.*, 1997; Ferrer-Sueta *et al.*, 1999). Basic studies on the chemistry of peroxynitrite and protein thiols (Radi *et al.*, 1991; Alvarez *et al.* 1999) culminated in the key discovery by Bryk *et al.* (2000) of the thiol-based catalytic peroxynitrite reduction by bacterial Prxs which paved the way to a better understanding of the fate of peroxynitrite in biological systems. A simple approach to understand the importance of the peroxiredoxin reaction in peroxynitrite biochemistry is represented in Table 3. The compiled results indicate that the reaction with the ubiquitous peroxiredoxins represent an important route for peroxynitrite detoxification in biological systems. This is consistent with cellular studies showing that these enzymes have



Table 3. Patterns of peroxynitrite reactivity with biomolecules in terms of rate constants, fate of the oxidant or biological impact

Target	$k^a$ ( $M^{-1}s^{-1}$ )	Conc. ( $\mu M$ )	$k_{app}^d$ ( $s^{-1}$ )	Observation	Fate	Ref.
<b>DIVERSION</b>						
CO <sub>2</sub>	$4.6 \times 10^4$	1,300	60	ubiquitous	CO <sub>3</sub> <sup>-</sup> + ·NO <sub>2</sub> (35%) CO <sub>2</sub> + NO <sub>3</sub> <sup>-</sup> (65%)	(Lymar <i>et al.</i> , 1995)
Myeloperoxidase	$4.6 \times 10^{7b}$	500	23,000	neutrophils	Compound II of the peroxidase	(Floris <i>et al.</i> , 1993)
<b>INACTIVATION</b>						
Hemoglobin	$2.3 \times 10^{4b}$	5,000	115	only in red blood cells	Isomerization to nitrate	(Denicola <i>et al.</i> , 1998)
Glutathione peroxidase	$1.8 \times 10^{7b}$	2	36	calculated for hepatocytes	Catalytic reduction to nitrite	(Briviba <i>et al.</i> , 1998)
Peroxiredoxin V	$1.6 \times 10^{8b,c}$	> 1	> 160	ubiquitous intracellular	Catalytic reduction to nitrite	(Dubuisson <i>et al.</i> , 2004)
TXNPx	$8.0 \times 10^5$	250	200	in <i>C. fasciculata</i>	Catalytic reduction to nitrite	(Trujillo <i>et al.</i> , 2004)
Glutathione	$1.4 \times 10^3$	5,000	7	ubiquitous intracellular	Reduction to nitrite	(Koppenol <i>et al.</i> , 1992)
<b>DAMAGE</b>						
Aconitase	$1.4 \times 10^5$	20	2.8	mitochondria	Oxidation, inactivation	(Castro <i>et al.</i> , 1998)
MnSOD	$1.0 \times 10^5$	20	2.0	mitochondria	Nitration, inactivation	(Quijano <i>et al.</i> , 2001)

<sup>a</sup> at pH 7.4 and 37°C, unless otherwise indicated

<sup>b</sup> values extrapolated to 37°C assuming a 2.3 times increase for each 12°C

<sup>c</sup> at pH 7.8

<sup>d</sup> Apparent rate constants for peroxynitrite reactivity ( $k_{app}$ ) with a selected target was calculated by multiplying the second order rate constant for the reaction ( $k$ ) by the reported concentration of the target (Conc.) in different cells or compartments indicated under Observation. By comparing  $k_{app}$  values for the reaction between peroxynitrite and different biologically relevant targets, the main fate of peroxynitrite in selected compartments/cellular systems can be inferred.

a role in modulating peroxynitrite-mediated cytotoxicity (Wong *et al.*, 2002; Barr *et al.*, 2003), and underscore their potential use as drug targets for the treatment of different infectious diseases.

The outstanding reactivity of the peroxiredoxin thiols toward peroxynitrite and the paucity of other efficient natural scavengers for this oxidant make us think that peroxynitrite detoxification is one of the main evolutionary reasons why these proteins are so abundant and widespread. Moreover, peroxynitrite can promote the oxidation of proteins containing essential thiols (Souza *et al.*, 1998), and over-oxidation of thiols to sulfinic acids and its reversion by sulfiredoxins has been implicated in the regulation of eukaryotic peroxiredoxins (Woo *et al.*, 2003; Budanov *et al.*, 2004). Also, Prxs were reported to specifically bind to various proteins in a redox-dependent manner (Hofmann *et al.*, 2002). Taking into account the recently proposed role of peroxynitrite in redox signaling, peroxiredoxins could interfere with such regulatory processes in different ways: i) by lowering the peroxynitrite concentration, ii) by covalent binding to components of signaling cascades and iii) by transiently permitting signaling due to reversible peroxynitrite-mediated shut off of Prx activity (Choi *et al.*, 2005; Rhee *et al.*, 2005; Rhee, 2006).

## ACKNOWLEDGEMENTS

We thank Bruno Manta, from the School of Science, Universidad de la República, Uruguay, for helpful discussion. R. R. is an International Research Scholar of the Howard Hughes Medical Institute. L.F. was supported by a FUTOUR 2000 grant of the BMWi, Germany.

## REFERENCES

- Akerman, S. E. and Müller, S., 2003, 2-Cys peroxiredoxin PfTrx-Px1 is involved in the antioxidant defence of *Plasmodium falciparum*. *Mol. Biochem. Parasitol.* **130**: 75–81.
- Akerman, S. E. and Müller, S., 2005, Peroxiredoxin-linked detoxification of hydroperoxides in *Toxoplasma gondii*. *J. Biol. Chem.* **280**: 564–570.
- Alvarez, B., Ferrer-Sueta, G., Freeman, B. A. and Radi, R., 1999, Kinetics of peroxynitrite reaction with amino acids and human serum albumin. *J. Biol. Chem.* **274**: 842–848.
- Alvarez, M. N., Trujillo, M. and Radi, R., 2002, Peroxynitrite formation from biochemical and cellular fluxes of nitric oxide and superoxide. *Meth. Enzymol.* **359**: 353–366.
- Bachschmid, M., Schildknecht, S. and Ullrich, V., 2005, Redox regulation of vascular prostanoid synthesis by the nitric oxide-superoxide system. *Biochem. Biophys. Res. Commun.* **338**: 536–542.
- Baker, L. M. and Poole, L. B., 2003, Catalytic mechanism of thiol peroxidase from *Escherichia coli*. Sulfenic acid formation and overoxidation of essential CYS61. *J. Biol. Chem.* **278**: 9203–9211.
- Baker, L. M., Raudonikiene, A., Hoffman, P. S. and Poole, L. B., 2001, Essential thioredoxin-dependent peroxiredoxin system from *Helicobacter pylori*: genetic and kinetic characterization. *J. Bacteriol.* **183**: 1961–1973.
- Barr, S. D. and Gedamu, L., 2003, Role of peroxidoxins in *Leishmania chagasi* survival. Evidence of an enzymatic defense against nitrosative stress. *J. Biol. Chem.* **278**: 10816–10823.
- Beckman, J. S., Beckman, T. W., Chen, J., Marshall, P. A. and Freeman, B. A., 1990, Apparent hydroxyl radical production by peroxynitrite: implications for endothelial injury from nitric oxide and superoxide. *Proc. Natl. Acad. Sci. USA* **87**: 1620–1624.

- Beckman, J. S., Estevez, A. G., Crow, J. P. and Barbeito, L., 2001, Superoxide dismutase and the death of motoneurons in ALS. *Trends. Neurosci.* **24**: S15–20.
- Belik, J., Jankov, R. P., Pan, J. and Tanswell, A. K., 2004, Peroxynitrite inhibits relaxation and induces pulmonary artery muscle contraction in the newborn rat. *Free Radic. Biol. Med.* **37**: 1384–1392.
- Biteau, B., Labarre, J. and Toledano, M. B., 2003, ATP-dependent reduction of cysteine-sulphinic acid by *S. cerevisiae* sulphiredoxin. *Nature* **425**: 980–984.
- Bohn, H., Schonafinger, K., 1989, Oxygen and oxidation promote the release of nitric oxide from sydnonimines. *J. Cardiovasc. Pharmacol.* **14** Suppl. 11:S6–12.
- Bonini, M. G. and Augusto, O., 2001, Carbon dioxide stimulates the production of thiyl, sulfinyl, and disulfide radical anion from thiol oxidation by peroxynitrite. *J. Biol. Chem.* **276**: 9749–9754.
- Boucher, I. W., McMillan, P. J., Gabrielsen, M., Akerman, S. E., Brannigan, J. A., Schnick, C., Brzozowski, A. M., Wilkinson, A. J. and Müller, S., 2006, Structural and biochemical characterization of a mitochondrial peroxiredoxin from *Plasmodium falciparum*. *Mol. Microbiol.* **61**: 948–959.
- Briviba, K., Kissner, R., Koppenol, W. H. and Sies, H., 1998, Kinetic study of the reaction of glutathione peroxidase with peroxynitrite. *Chem. Res. Toxicol.* **11**: 1398–1401.
- Bryk, R., Griffin, P. and Nathan, C., 2000, Peroxynitrite reductase activity of bacterial peroxiredoxins. *Nature* **407**: 211–215.
- Budanov, A. V., Sablina, A. A., Feinstein, E., Koonin, E. V. and Chumakov, P. M., 2004, Regeneration of peroxiredoxins by p53-regulated sestrins, homologs of bacterial AhpD. *Science* **304**: 596–600.
- Budde, H., Flohé, L., Hecht, H. J., Hofmann, B., Stehr, M., Wissing, J. and Lünsdorf, H., 2003, Kinetics and redox-sensitive oligomerisation reveal negative subunit cooperativity in trypanoxin peroxidase of *Trypanosoma brucei brucei*. *Biol. Chem.* **384**: 619–633.
- Carnieri, E. G., Moreno, S. N. and Docampo, R., 1993, Trypanothione-dependent peroxide metabolism in *Trypanosoma cruzi* different stages. *Mol. Biochem. Parasitol.* **61**: 79–86.
- Castro, H., Budde, H., Flohé, L., Hofmann, B., Lünsdorf, H., Wissing, J. and Tomas, A. M., 2002, Specificity and kinetics of a mitochondrial peroxiredoxin of *Leishmania infantum*. *Free Radic. Biol. Med.* **33**: 1563–1574.
- Castro, H., Sousa, C., Novais, M., Santos, M., Budde, H., Cordeiro-da-Silva, A., Flohé, L. and Tomas, A. M., 2004, Two linked genes of *Leishmania infantum* encode trypanoxins localised to cytosol and mitochondrion. *Mol. Biochem. Parasitol.* **136**: 137–147.
- Castro, L. A., Robalinho, R. L., Cayota, A., Meneghini, R. and Radi, R., 1998, Nitric oxide and peroxynitrite-dependent aconitase inactivation and iron-regulatory protein-1 activation in mammalian fibroblasts. *Arch. Biochem. Biophys.* **359**: 215–224.
- Cowell, R. M. and Russell, J. W., 2004, Nitrosative injury and antioxidant therapy in the management of diabetic neuropathy. *J. Investig. Med.* **52**: 33–44.
- Chae, H. Z., Kim, H. J., Kang, S. W. and Rhee, S. G., 1999, Characterization of three isoforms of mammalian peroxiredoxin that reduce peroxides in the presence of thioredoxin. *Diabetes Res. Clin. Pract.* **45**: 101–112.
- Chang, T. S., Jeong, W., Woo, H. A., Lee, S. M., Park, S. and Rhee, S. G., 2004, Characterization of mammalian sulfiredoxin and its reactivation of hyperoxidized peroxiredoxin through reduction of cysteine sulfinic acid in the active site to cysteine. *J. Biol. Chem.* **279**: 50994–51001.
- Choi, M. H., Lee, I. K., Kim, G. W., Kim, B. U., Han, Y. H., Yu, D. Y., Park, H. S., Kim, K. Y., Lee, J. S., Choi, C., Bae, Y. S., Lee, B. I., Rhee, S. G. and Kang, S. W., 2005, Regulation of PDGF signalling and vascular remodelling by peroxiredoxin II. *Nature* **435**: 347–353.
- Dalziel, K., 1957, Initial steady state velocities in the evaluation of enzyme-substrate reaction mechanisms. *Acta Chem. Scand.* **11**: 1706–1723.
- Denicola, A., Souza, J. M. and Radi, R., 1998, Diffusion of peroxynitrite across erythrocyte membranes. *Proc. Natl. Acad. Sci. USA* **95**: 3566–3571.
- Dubuisson, M., Vander Stricht, D., Clippe, A., Etienne, F., Nausier, T., Kissner, R., Koppenol, W. H., Rees, J. F. and Knoops, B., 2004, Human peroxiredoxin 5 is a peroxynitrite reductase. *FEBS Lett.* **571**: 161–165.

- Ferrer-Sueta, G., Batinic-Haberle, I., Spasojevic, I., Fridovich, I. and Radi, R., 1999, Catalytic scavenging of peroxynitrite by isomeric Mn(III) N-methylpyridylporphyrins in the presence of reductants. *Chem. Res. Toxicol.* **12**: 442–449.
- Ferrer-Sueta, G., Quijano, C., Alvarez, B. and Radi, R., 2002, Reactions of manganese porphyrins and manganese-superoxide dismutase with peroxynitrite. *Meth. Enzymol.* **349**: 23–37.
- Flohé, L., 1989, The selenoprotein glutathione peroxidase. John Wiley & Sons, Inc. New York, pp 643–732.
- Flohé, L. and Brigelius-Flohé, 2001, Selenoproteins of the glutathione system. Selenium: Its molecular biology and role in human health. Hatfield. Boston/Dordrecht/London, Kluwer Academic Publishers, pp 157–178.
- Flohé, L., Budde, H., Bruns, K., Castro, H., Clos, J., Hofmann, B., Kansal-Kalavar, S., Krumme, D., Menge, U., Plank-Schumacher, K., Sztajer, H., Wissing, J., Wylegalla, C. and Hecht, H. J., 2002, Tryparedoxin peroxidase of *Leishmania donovani*: molecular cloning, heterologous expression, specificity, and catalytic mechanism. *Arch. Biochem. Biophys.* **397**: 324–335.
- Floris, R., Piersma, S. R., Yang, G., Jones, P. and Wever, R., 1993, Interaction of myeloperoxidase with peroxynitrite. A comparison with lactoperoxidase, horseradish peroxidase and catalase. *Eur. J. Biochem.* **215**: 767–775.
- Fu, Y., Sies, H. and Lei, X. G., 2001, Opposite roles of selenium-dependent glutathione peroxidase-1 in superoxide generator diquat- and peroxynitrite-induced apoptosis and signaling. *J. Biol. Chem.* **276**: 43004–43009.
- Gerasimov, O. V. and Lyman, S. V., 1999, The yield of hydroxyl radical from the decomposition of peroxynitrous acid. *Inorg. Chem.* **38**: 4317–4321.
- Glebska, J. and Koppenol, W. H., 2003, Peroxynitrite-mediated oxidation of dichlorodihydrofluorescein and dihydrorhodamine. *Free Radic. Biol. Med.* **35**: 676–682.
- Guerrero, S. A., Lopez, J. A., Steinert, P., Montemartini, M., Kalisz, H. M., Colli, W., Singh, M., Alves, M. J. and Flohé, L., 2000, His-tagged tryparedoxin peroxidase of *Trypanosoma cruzi* as a tool for drug screening. *Appl. Microbiol. Biotechnol.* **53**: 410–414.
- Hodges, G. R. and Ingold, K. U., 1999, Cage-escape of germinate radical pairs can produce peroxynitrite from peroxynitrite under a wide variety of experimental conditions. *J. Am. Chem. Soc.* **121**: 10695–10701.
- Hofmann, B., Hecht, H. J. and Flohé, L., 2002, Peroxiredoxins. *Biol. Chem.* **383**: 347–364.
- Holmgren, A., 1972, Tryptophan fluorescence study of conformational transitions of the oxidized and reduced form of thioredoxin. *J. Biol. Chem.* **247**: 1992–1998.
- Jaeger, T., Budde, H., Flohé, L., Menge, U., Singh, M., Trujillo, M. and Radi, R., 2004, Multiple thioredoxin-mediated routes to detoxify hydroperoxides in *Mycobacterium tuberculosis*. *Arch. Biochem. Biophys.* **423**: 182–191.
- Jeong, W., Cha, M. K. and Kim, I. H., 2000, Thioredoxin-dependent hydroperoxide peroxidase activity of bacterioferritin comigratory protein (BCP) as a new member of the thiol-specific antioxidant protein (TSA)/Alkyl hydroperoxide peroxidase C (AhpC) family. *J. Biol. Chem.* **275**: 2924–2930.
- Koppenol, W. H., Moreno, J. J., Pryor, W. A., Ischiropoulos, H. and Beckman, J. S., 1992, Peroxynitrite, a cloaked oxidant formed by nitric oxide and superoxide. *Chem. Res. Toxicol.* **5**: 834–842.
- Lee, J., Hunt, J. A. and Groves, J. T., 1997, Rapid decomposition of peroxynitrite by manganese porphyrin-antioxidant redox couples. *Bioinorg Med Chem Lett.* **7**: 2913–2918.
- Linares, E., Giorgio, S., Mortara, R. A., Santos, C. X., Yamada, A. T. and Augusto, O., 2001, Role of peroxynitrite in macrophage microbicidal mechanisms in vivo revealed by protein nitration and hydroxylation. *Free Radic. Biol. Med.* **30**: 1234–1242.
- Lyman, S. V. and Hurst, J. K., 1995, Rapid reaction between peroxynitrite ion and carbon dioxide: implications for biological activity. *J. Am. Chem. Soc.* **117**: 8867–8868.
- McCafferty, D. M., 2000, Peroxynitrite and inflammatory bowel disease. *Gut* **46**: 436–9.
- Mills, G. C., 1957, Hemoglobin catabolism. I. Glutathione peroxidase, an erythrocyte enzyme which protects hemoglobin from oxidative breakdown. *J. Biol. Chem.* **229**: 189–197.

- Montemartini, M., Nogoceke, E., Singh, M., Steinert, P., Flohé, L. and Kalisz, H. M., 1998, Sequence analysis of the trypanothione peroxidase gene from *Crithidia fasciculata* and its functional expression in *Escherichia coli*. *J. Biol. Chem.* **273**: 4864–4871.
- Munhoz, D. C. and Netto, L. E., 2004, Cytosolic thioredoxin peroxidase I and II are important defenses of yeast against organic hydroperoxide insult: catalases and peroxiredoxins cooperate in the decomposition of H<sub>2</sub>O<sub>2</sub> by yeast. *J. Biol. Chem.* **279**: 35219–35227.
- Naussser, T. and Koppenol, W. H., 2002, The rate constant of the reaction of superoxide with nitrogen monoxide: approaching the diffusion limit. *J. Phys. Chem. A* **106**: 4084–4086.
- Naviliat, M., Gualco, G., Cayota, A. and Radi, R., 2005, Protein 3-nitrotyrosine formation during *Trypanosoma cruzi* infection in mice. *Braz. J. Med. Biol. Res.* **38**: 1825–1834.
- Nickel, C., Trujillo, M., Rahlfs, S., Deponte, M., Radi, R. and Becker, K., 2005, Plasmodium falciparum 2-Cys peroxiredoxin reacts with plasmoredoxin and peroxynitrite. *Biol. Chem.* **386**: 1129–1136.
- Nogoceke, E., Gommel, D. U., Kiess, M., Kalisz, H. M. and Flohé, L., 1997, A unique cascade of oxidoreductases catalyses trypanothione-mediated peroxide metabolism in *Crithidia fasciculata*. *Biol. Chem.* **378**: 827–836.
- Ogusucu, R., Rettori, D., Munhoz, D. C., Netto, L. E. S. and Augusto, O., 2007, Reactions of yeast cytosolic thioredoxin peroxidase I and II with hydrogen peroxide and peroxynitrite: rate constants by competitive kinetics. *Free Radic. Biol. Med.* **42**: 326–334.
- Oishi, P., Grobe, A., Benavidez, E., Ovidia, B., Harmon, C., Ross, G. A., Hendricks-Munoz, K., Xu, J., Black, S. M. and Fineman, J. R., 2006, Inhaled nitric oxide induced NOS inhibition and rebound pulmonary hypertension: a role for superoxide and peroxynitrite in the intact lamb. *Am. J. Physiol. Lung Cell. Mol. Physiol.* **290**: L359–L366.
- Pacher, P., Obrosova, I. G., Mabley, J. G. and Szabo, C., 2005, Role of nitrosative stress and peroxynitrite in the pathogenesis of diabetic complications. Emerging new therapeutical strategies. *Curr. Med. Chem.* **12**: 267–275.
- Parsonage, D., Youngblood, D. S., Sarma, G. N., Wood, Z. A., Karplus, P. A. and Poole, L. B., 2005, Analysis of the link between enzymatic activity and oligomeric state in AhpC, a bacterial peroxiredoxin. *Biochemistry* **44**: 10583–10592.
- Peshenko, I. V. and Shichi, H., 2001, Oxidation of active center cysteine of bovine 1-Cys peroxiredoxin to the cysteine sulfenic acid form by peroxide and peroxynitrite. *Free Radic. Biol. Med.* **31**: 292–303.
- Peshenko, I. V., Singh, A. K. and Shichi, H., 2001, Bovine eye 1-Cys peroxiredoxin: expression in *E. coli* and antioxidant properties. *J. Ocul. Pharmacol. Ther.* **17**: 93–99.
- Peskin, A. V. and Winterbourn, C. C., 2001, Kinetics of the reactions of hypochlorous acid and amino acid chloramines with thiols, methionine, and ascorbate. *Free Radic. Biol. Med.* **30**: 572–579.
- Quijano, C., Hernandez-Saavedra, D., Castro, L., McCord, J. M., Freeman, B. A. and Radi, R., 2001, Reaction of peroxynitrite with Mn-superoxide dismutase. Role of the metal center in decomposition kinetics and nitration. *J. Biol. Chem.* **276**: 11631–11638.
- Radi, R., 2004, Nitric oxide, oxidants, and protein tyrosine nitration. *Proc. Natl. Acad. Sci. USA* **101**: 4003–4008.
- Radi, R., Beckman, J. S., Bush, K. M. and Freeman, B. A., 1991, Peroxynitrite oxidation of sulfhydryls. The cytotoxic potential of superoxide and nitric oxide. *J. Biol. Chem.* **266**: 4244–4250.
- Radi, R., Denicola, A., Alvarez, B., Ferrer-Sueta, G. and Rubbo, H., 2000, The biological chemistry of peroxynitrite. *Nitric Oxide Biology and Pathobiology*. J. L. Ignarro. San Diego, Academic Press: 57–82.
- Rhee, S. G., 2006, Cell signaling. H<sub>2</sub>O<sub>2</sub>, a necessary evil for cell signaling. *Science* **312**: 1882–1883.
- Rhee, S. G., Kang, S. W., Jeong, W., Chang, T. S., Yang, K. S. and Woo, H. A., 2005, Intracellular messenger function of hydrogen peroxide and its regulation by peroxiredoxins. *Curr. Opin. Cell Biol.* **17**: 183–189.
- Rouhier, N., Gelhaye, E., Corbier, C. and Jacquot, J. P., 2004, Active site mutagenesis and phospholipid hydroperoxide reductase activity of poplar type II peroxiredoxin. *Physiol. Plant* **120**: 57–62.
- Rouhier, N., Gelhaye, E., Gualberto, J. M., Jordy, M. N., De Fay, E., Hirasawa, M., Duplessis, S., Lemaire, S. D., Frey, P., Martin, F., Manieri, W., Knaff, D. B. and Jacquot, J. P., 2004, Poplar

- peroxiredoxin Q. A thioredoxin-linked chloroplast antioxidant functional in pathogen defense. *Plant Physiol.* **134**: 1027–1038.
- Sayed, A. A. and Williams, D. L., 2004, Biochemical characterization of 2-Cys peroxiredoxins from *Schistosoma mansoni*. *J. Biol. Chem.* **279**: 26159–26166.
- Seo, M. S., Kang, S. W., Kim, K., Baines, I. C., Lee, T. H. and Rhee, S. G., 2000, Identification of a new type of mammalian peroxiredoxin that forms an intramolecular disulfide as a reaction intermediate. *J. Biol. Chem.* **275**: 20346–20354.
- Sies, H. and Masumoto, H., 1997, Ebselen as a glutathione peroxidase mimic and as a scavenger of peroxynitrite. *Adv. Pharmacol.* **38**: 229–246.
- Souza, J. M., Giasson, B. I., Chen, Q., Lee, V. M. and Ischiropoulos, H., 2000, Dityrosine cross-linking promotes formation of stable alpha-synuclein polymers. Implication of nitrate and oxidative stress in the pathogenesis of neurodegenerative synucleinopathies. *J. Biol. Chem.* **275**: 18344–18349.
- Souza, J. M. and Radi, R., 1998, Glyceraldehyde-3-phosphate dehydrogenase inactivation by peroxynitrite. *Arch. Biochem. Biophys.* **360**: 187–194.
- Steinert, P., Plank-Schumacher, K., Montemartini, M., Hecht, H. J. and Flohé, L., 2000, Permutation of the active site motif of tryparedoxin 2. *Biol. Chem.* **381**: 211–219.
- Szabo, C., 2003, Multiple pathways of peroxynitrite cytotoxicity. *Toxicol. Lett.* **140–141**: 105–112.
- Szajewski, R. P. and Whiteside, G. M., 1980, Rate constants and equilibrium constants for thiol-disulfide interchange reactions involving oxidized glutathione. *J. Am. Chem. Soc.* **102**: 2011–2026.
- Touyz, R. M., 2005, Reactive oxygen species as mediators of calcium signaling by angiotensin II: implications in vascular physiology and pathophysiology. *Antioxid. Redox Signal* **7**: 1302–1314.
- Trujillo, M., Budde, H., Pineyro, M. D., Stehr, M., Robello, C., Flohé, L. and Radi, R., 2004, *Trypanosoma brucei* and *Trypanosoma cruzi* tryparedoxin peroxidases catalytically detoxify peroxynitrite via oxidation of fast reacting thiols. *J. Biol. Chem.* **279**: 34175–34182.
- Trujillo, M., Mauri, P., Benazzi, L., Comini, M., De Palma, A., Flohé, L., Radi, R., Stehr, M., Singh, M., Ursini, F. and Jaeger, T., 2006, The mycobacterial thioredoxin peroxidase can act as a one-cysteine-peroxiredoxin. *J. Biol. Chem.* **281**: 20555–20566.
- Trujillo, M. and Radi, R., 2002, Peroxynitrite reaction with the reduced and the oxidized forms of lipoic acid: new insights into the reaction of peroxynitrite with thiols. *Arch. Biochem. Biophys.* **397**: 91–98.
- Wong, C. M., Zhou, Y., Ng, R. W., Kung Hf, H. F. and Jin, D. Y., 2002, Cooperation of yeast peroxiredoxins Tsa1p and Tsa2p in the cellular defense against oxidative and nitrosative stress. *J. Biol. Chem.* **277**: 5385–5394.
- Woo, H. A., Chae, H. Z., Hwang, S. C., Yang, K. S., Kang, S. W., Kim, K. and Rhee, S. G., 2003, Reversing the inactivation of peroxiredoxins caused by cysteine sulfinic acid formation. *Science* **300**: 653–656.
- Woo, H. A., Jeong, W., Chang, T. S., Park, K. J., Park, S. J., Yang, J. S. and Rhee, S. G., 2005, Reduction of cysteine sulfinic acid by sulfiredoxin is specific to 2-cys peroxiredoxins. *J. Biol. Chem.* **280**: 3125–3128.
- Wood, Z. A., Poole, L. B. and Karplus, P. A., 2003, Peroxiredoxin evolution and the regulation of hydrogen peroxide signaling. *Science* **300**: 650–653.
- Wood, Z. A., Schröder, E., Harris, J. R. and Poole, L. B., 2003, Structure, mechanism and regulation of peroxiredoxins. *Trends Biochem. Sci.* **28**: 32–40.
- Wrona, M., Patel, K. and Wardman, P., 2005, Reactivity of 2',7'-dichlorodihydrofluorescein and dihydrorhodamine 123 and their oxidized forms toward carbonate, nitrogen dioxide, and hydroxyl radicals. *Free Radic. Biol. Med.* **38**: 262–270.
- Yang, K. S., Kang, S. W., Woo, H. A., Hwang, S. C., Chae, H. Z., Kim, K. and Rhee, S. G., 2002, Inactivation of human peroxiredoxin I during catalysis as the result of the oxidation of the catalytic site cysteine to cysteine-sulfinic acid. *J. Biol. Chem.* **277**: 38029–38036.

## CHAPTER 6

# THE PEROXIREDOXIN REPAIR PROTEINS

THOMAS J. JÖNSSON AND W. TODD LOWTHER

*Center for Structural Biology, Department of Biochemistry, Wake Forest University School of Medicine, Winston-Salem, North Carolina, 27157, USA*

**Abstract:** Sulfiredoxin and sestrin are cysteine sulfinic acid reductases that selectively reduce or repair the hyperoxidized forms of typical 2-Cys peroxiredoxins within eukaryotes. As such these enzymes play key roles in the modulation of peroxide-mediated cell signaling and cellular defense mechanisms. The unique structure of sulfiredoxin facilitates access to the peroxiredoxin active site and novel sulfur chemistry

**Keywords:** Cysteine sulfinic acid, Retroreduction, Sulfiredoxin, Sestrin

### 1. INTRODUCTION

The typical 2-Cys subclass of peroxiredoxins (Prxs) is a homodimer in which the peroxidatic cysteine residue (Cys-S<sub>p</sub>H) from one monomer attacks the O-O bond of the ROOH substrate, producing the first product (ROH) and the oxidized, sulfenic acid (Cys-S<sub>p</sub>OH) of the peroxidatic cysteine (Hofmann *et al.*, 2002; Wood *et al.*, 2003). During normal catalysis the resolving Cys residue (Cys-S<sub>R</sub>H), located on the C-terminus of the adjacent monomer, reacts with the sulfenic acid intermediate to form a disulfide bond. Eukaryotic, typical 2-Cys Prxs are unique in that the sulfenic acid intermediate can react with a second molecule of peroxide to form a sulfinic acid (Cys-S<sub>p</sub>O<sub>2</sub><sup>-</sup>). This hyperoxidized Cys modification can occur under oxidative stress conditions and leads to a loss in peroxidase activity. It has long been thought that this type of modification was irreversible (Claiborne *et al.*, 1999). With the discovery of the sulfinic acid reductases, sulfiredoxin (Srx) and sestrin, not only is this modification reversible, but may play a key role in regulating peroxide-mediated cell signaling by acting as a sulfinic acid switch (Jacob *et al.*, 2004). Sulfiredoxin employs many novel structural and catalytic strategies to specifically repair or retroreduce typical 2-Cys Prxs. Currently little is known about the sestrins, but these proteins appear to utilize a similar catalytic mechanism despite no known similarity to Srx.

## 2. THE HYPEROXIDATION OF PEROXIREDOXINS

Early studies on oxidative stress in yeast revealed that a 25 kDa protein called thiol specific antioxidant protein (TSA) was able to protect glutamate synthetase from inactivation in the presence of  $\text{Fe}^{3+}$ ,  $\text{O}_2$  and dithiothreitol (DTT) (Kim *et al.*, 1985). TSA was later shown to belong to the ubiquitous peroxiredoxin family (Chae *et al.*, 1994) that uses redox-sensitive cysteine residues to detoxify hydrogen peroxide, lipid hydroperoxides and peroxyxynitrite. As a result of kinetic studies that showed TSA receives reducing equivalents from the NADPH/thioredoxin reductase/thioredoxin system to break down hydrogen peroxide, tert-butyl peroxide and cumene peroxide, TSA was renamed thioredoxin peroxidase (TPx) (Chae *et al.*, 1999). The rate of peroxide removal was initially fast and decreased gradually when 1 mM  $\text{H}_2\text{O}_2$  was used as the substrate (Chae *et al.*, 1994). However, 5 mM  $\text{H}_2\text{O}_2$  caused a marked decrease in the rate of peroxide consumption. Substrate inactivation was also more rapid with t-butyl peroxide. Peroxide consumption was restored by replenishing the reaction with TPx. The decrease in rate was not attributed to the exhaustion of substrate or product inhibition by  $\text{NADP}^+$ , but rather to the inactivation of TPx by peroxide. Substrate inactivation was also shown to occur in the peroxiredoxins (Prxs) from Kinetoplastida, including *Leishmania major*, *L. donovani* and *Trypanosoma brucei*, but not in *Crithidia fasciculata* (Nogoceke *et al.*, 1997; Castro *et al.*, 2002; Flohé *et al.*, 2002; Budde *et al.*, 2003). In contrast, the homologous bacterial peroxiredoxin AhpC efficiently detoxifies mM levels of hydrogen peroxide and cumene peroxide without any indication of peroxide-dependent inactivation (Niimura *et al.*, 1995; Poole, 1996). Furthermore, *in vivo* peroxide stress studies in *Salmonella typhimurium* showed no indication of post-translational modification in AhpC (Christman *et al.*, 1985; Morgan *et al.*, 1986).

A clearer understanding of substrate inhibition within Prxs came from the determination of the crystal structure of human PrxII, a typical 2-Cys Prx, purified from red blood cells (Schröder *et al.*, 2000). Surprisingly, the peroxidatic cysteine, Cys51, was found in the sulfinic acid form, suggesting that excess peroxide had post-translationally modified the cysteine via the sulfenic acid intermediate routinely used in catalysis. It was unclear at the time whether this unique derivative among Prx structures was a crystallographic artifact or could be formed *in vivo*. Studies on oxidative stress in human cell lines using 2D-PAGE analysis demonstrated that most Prxs are converted into variants with a lower isoelectric point (pI) upon exposure to hydroperoxides (Mitsumoto *et al.*, 2001). The acidic shift was contributed to phosphorylation or sulfinic acid formation, modifications that were later proven to be possible (Chang *et al.*, 2002; Chevallet *et al.*, 2003). These findings led the Rhee laboratory to investigate the nature of substrate inactivation in human Prxs (Yang *et al.*, 2002). Initial studies on recombinant PrxI-III showed similar substrate inhibition previously observed with yeast TPx (Chae, 1999). Further studies showed that inactivation of PrxI activity was coincident with the conversion of PrxI to a more acidic species (Yang *et al.*, 2002). Mass spectral analysis and studies with cysteine mutants determined that the shift in pI was due to selective oxidation of the catalytic site Cys51-SH to Cys51-SO<sub>2</sub><sup>-</sup> when in the presence of a thiol reductant



and excess hydrogen peroxide. Kinetic analysis of PrxI inactivation in the presence of a low, steady-state level ( $< 1$  mM) of  $H_2O_2$  indicated that PrxI was hyperoxidized at a rate of 0.072% per turnover at 30°C.

Concurrent with the studies on human PrxI, the Chae laboratory purified a truncated form of TPx from *Schizosaccharomyces pombe* that showed resistance to inactivation by  $H_2O_2$  when compared to the full-length form of the enzyme. This observation was further examined by generating a series of C-terminal truncations in the recombinant protein. Only the C-terminal truncation that removed residues 176–191 lead to a loss in peroxide sensitivity, suggesting that these residues play an important role in inactivation. Moreover, transformation of wild-type *S. pombe* with a construct bearing the oxidation-resistant, C-terminally truncated TPx provided protection against peroxide stress (Koo *et al.*, 2002).

A rationale for why only some Prxs are hyperoxidized to the sulfinic acid form came from comparing the structure of *S. typhimurium* AhpC (C46S mutant) with human PrxII (Wood *et al.*, 2003). AhpC lacks an YF motif-containing, C-terminal helix which in PrxII interacts with a conserved GGLG-motif in close proximity to the peroxidatic cysteine. It is thought that these additional structural motifs hinder or slow the ability of the resolving cysteine to access the peroxidatic cysteine located  $\sim 13$  Å away. As a result this kinetic “pause” leaves the Cys-S<sub>p</sub>OH intermediate increasingly exposed to attack by another peroxide molecule resulting in hyperoxidation to the sulfinic acid form. This model is consistent with the findings presented above for the truncated form of *S. pombe* TPx. Removal of the C-terminal helix in TPx most likely allows for a faster attack of the resolving cysteine on the sulfinic acid intermediate and thereby prevents hyperoxidation.

### 3. RETROREDUCTION OF TYPICAL 2-CYS PEROXIREDOXINS

Protein cysteine sulfinic acid formation is not unusual given that 1–2% of the cysteine residues of soluble proteins from rat liver were detected in this oxidation state (Hamann *et al.*, 2002). Until recently these cysteine derivatives were viewed as irreversible; although sulfinic acids can be reduced *in vitro* by reductants such as 2-mercaptoethanol under very acidic ( $< pH4$ ) conditions (Finlayson, 1979; Claiborne *et al.*, 1999). Interestingly, bacteria have enzymatic systems, such as the *E. coli* SsuE and SsuD, that during sulfate starvation scavenge sulfur from alkane sulfonates to generate the corresponding aldehyde and sulfite (Eichhorn *et al.*, 1999).

The first indication of cysteine sulfinic acid reduction *in vivo* came when Woo *et al.* monitored the response of human cells to  $H_2O_2$  treatment using metabolic  $^{35}S$ -labeling of proteins and 2D-PAGE analysis (Woo *et al.*, 2003). Peroxide treatment led to the immediate hyperoxidation of Prx I and PrxII and an acidic shift of the protein spot. Other early experiments detected the overoxidation of five of the six Prx isoforms in humans (Prxs I–IV and VI) (Mitsumoto *et al.*, 2001). The spot shift was reversed with similar rates in several cell types even in the presence of cycloheximide which prevents new protein synthesis (Woo *et al.*, 2003). Chevallet *et al.*, in contrast, found that the repair of PrxII in HeLa cells was more efficient

than that of PrxI (Chevallet *et al.*, 2003). In HepG2 liver cells PrxI and PrxII were repaired at the same rate (Cesaratto *et al.*, 2005).

### 3.1. Discovery and Initial Characterization of Sulfiredoxin

The critical breakthrough in the field of cysteine oxidation and reversal came with the identification of the protein in *Saccharomyces cerevisiae* designated “sulfiredoxin” (abbreviated Srx1). Srx1 catalyzes the reversal of the hyperoxidized forms of two yeast Prxs (Tsa1 and Tsa2; also know as TPxI and TPxII) (Biteau *et al.*, 2003). Srx1 was identified through a screen for hydrogen peroxide-induced genes. Srx1 mRNA levels were tremendously increased (> 200-fold) in the first 15 minutes after peroxide treatment. Moreover, deletion of the Srx1 gene caused a decreased tolerance to hydrogen peroxide treatment. Several lines of evidence suggested that Srx1 might have some involvement in modulating the redox state of Prxs: the identification of peroxide-induced complexes *in vivo* between HA-tagged or 6His-tagged Srx1 and Tsa1. The former complexes were not formed with the putative catalytic cysteine (C84S) Srx1 mutant or the  $\Delta tsa1$  strain. The latter complexes were DTT-sensitive suggesting that a disulfide bond had formed between the two proteins. Moreover, wild-type Srx1, but not the C84S mutant, was able to restore the repair of Tsa1 in  $\Delta srx1$  cells as monitored by 2D-PAGE analyses. The addition of cycloheximide to cells also caused a delay in the repair of Tsa1 suggesting that *de novo* protein synthesis is required for efficient Cys sulfinic acid reduction.

In *in vitro* studies, recombinant Srx1 was able to reduce hyperoxidized Tsa1 (either generated in peroxide-treated cells or in purified form) in the presence of ATP and  $Mg^{2+}$  or  $Mn^{2+}$ , but not other metals. In these studies the reduction of the sulfinic acid moiety was monitored using 4-acetamido-4'-maleimidylstilbene-2, 2'-disulfonic acid (AMS) labeling and SDS-PAGE analysis. AMS covalently modifies free thiol groups yielding a  $\sim 500$  Da increase in mass. Thus upon reduction of the sulfinic acid group to the thiol form, an increase in the mass of the Prx can be readily visualized. Unexpectedly, ADP supported Srx1-dependent catalysis, although less efficiently, and neither GTP nor AMP-PNP, a non-hydrolyzable ATP homologue, acted as inhibitors of catalysis. A reductant, either DTT or thioredoxin, was also required for the return of the Tsa1-SO<sub>2</sub><sup>-</sup> to the Tsa1-SH form. As shown in the *in vivo* studies, the recombinant C84S mutant of Srx1 was inactive.

Given the requirement for ATP hydrolysis, generation of a phosphorylated intermediate, a sulfinic phosphoryl ester, was hypothesized (Fig. 1) (Biteau *et al.*, 2003). The investigators were not able to detect this intermediate, however, presumably due to its highly unstable nature. The apparent involvement of Cys84 in the covalent linkage to Tsa1 also led Toledano and coworkers to hypothesize the nucleophilic attack of Cys84-SH on the phosphorylated intermediate, resulting in formation of a thiosulfinate bond, i.e. a disulfide mono-oxide. Resolution of this complex with excess reductant would then return both enzymes to their reduced states through hypothesized Prx-SOH and Srx1-S-S-R intermediates.

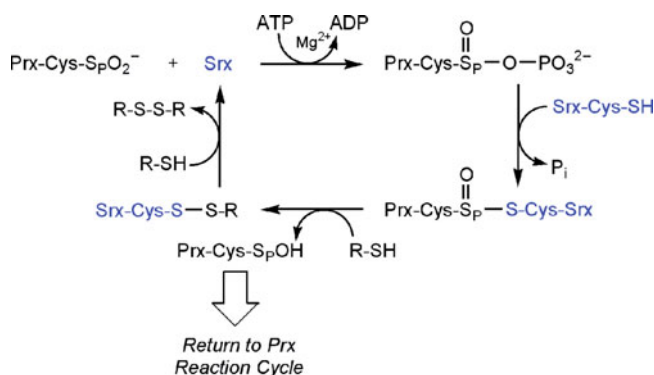

Figure 1. Proposed reaction mechanism for the reduction of the cysteine-sulfinic acid of Tsa1 by yeast Srx1. The reaction proceeds from a sulfinic acid through sulfinic phosphoryl ester and thiosulfinate intermediates (Biteau *et al.*, 2003). The position of ATP hydrolysis and the identity of the exogenous thiol (R-SH) were proposed to be between the  $\beta$ - $\gamma$  phosphate and thioredoxin, respectively (See Plate 9)

### 3.2. Discovery and Initial Characterization of Sestrin

The sestrin family of proteins has also been shown to repair Prxs (Budanov *et al.*, 2004). The sestrins are  $\sim 48$ – $60$  kDa in size and show no sequence homology to the Srx family. The sestrins were originally discovered through subtractive cDNA cloning experiments designed to identify targets of the p53 protein (Velasco-Miguel *et al.*, 1999). One of the predominant genes identified by the Kley laboratory was PA26 (p53-activated protein #26, also known as sestrin 1). Treatment of cells with genotoxic agents (e.g. the anti-cancer agent doxorubicin, UV- and  $\gamma$ -radiation) induced the mRNA levels of PA26 in a p53-dependent manner. These results are consistent with p53 induction and activation as a result of DNA damage and oxidative stress. The characterization of the PA26 gene and its transcripts revealed the presence of an intragenic p53 response element and three transcripts (T1, T2 and T3) of different size. The transcripts result in the production of three proteins that differ in sequence and length at their N-termini in *in vitro* transcription/translation experiments. *In vivo* data, however, suggests that the predominant transcript/protein is the PA26-T2 variant. Moreover, the T2 variant is also upregulated by serum deprivation (Velasco-Miguel *et al.*, 1999). This latter characteristic has been used to further classify PA26 as a Growth Arrest and DNA Damage (GADD) inducible gene.

Subsequently, the Hi95 protein (sestrin 2) and sestrin 3 were identified through cDNA microarray experiments designed to discover genes upregulated in the hypoxia response. The induction by hypoxia treatment is p53 independent while the induction by oxidative stress and DNA damage is p53 dependent and modulated by serum levels as seen for PA26 (Budanov *et al.*, 2002). Moreover, the overexpression of Hi95 protects cells from hydrogen peroxide treatment. While these studies and those for PA26 support a role for these proteins in the p53-regulated response to

environmental stressors, the biological function of the sestrins was not proposed until it was recognized that the sestrins repair oxidized Prxs (Budanov *et al.*, 2004). Based on the low sequence homology (less than 20% for only the first 200/551 residues) to proteins that are known to interact with bacterial Prxs, Chumakov's group suspected that Hi95 may interact with human Prxs. In a series of experiments they showed that: (i) Hi95 repairs both human PrxI and PrxII; (ii) inhibition of Hi95 by siRNAs leads to higher intracellular levels of ROS while overexpression leads to lower ROS levels; and (iii) enzymatic activity *in vitro* requires a critical cysteine residue, ATP,  $Mg^{+2}$  and the reductant DTT. These characteristics suggest that the sestrin-catalyzed repair of Prxs may be similar to that proposed for Srx despite the lack of any sequence similarity and the disparity in size. The identification of two reductase families supports the cellular importance of the reduction of the sulfinic acid moiety. Moreover, it is intriguing to postulate that Srx and the sestrins modulate the activity of proteins/enzymes other than the Prxs in humans (Budanov *et al.*, 2004). At this time no further characterization of the sulfinic acid reductase activity of sestrins has been reported. Data presented from the Rhee laboratory in section 6.2 has shown that Srx is specific for typical 2-Cys Prxs (Woo *et al.*, 2005).

#### 4. DISTRIBUTION OF PRX REPAIR ENZYMES

The hyperoxidation of typical 2-Cys Prxs and their repair by Srx and sestrins are highly correlated. Tissue and organellar localization may play a key role in some oxidative stress responses. Srx exhibits a much broader organismal distribution than sestrin while maintaining strong sequence conservation.

##### 4.1. Prx Oxidation Susceptibility and Repair Correlations

Typical 2-Cys Prxs have conserved features across all kingdoms with 30% or higher sequence identity. The most conserved regions include the peroxidative cysteine within the DFTFVCPTEI motif and the resolving cysteine within the VCP-motif. The YF helix and GGLG structural motifs, as described earlier, promote hyperoxidation and have been identified in most eukaryotic organisms and cyanobacteria (Wood *et al.*, 2003). Many bacteria contain a GG(L/I)G motif, but the critical YF-motif is substituted with a YL motif resulting in a Prx that is insensitive to hyperoxidation (Baker *et al.*, 2001). Interestingly, these bacteria do not contain the genes for sulfiredoxin or sestrin. In summary, Srxs are only found in organisms that contain peroxide-sensitive Prxs. This observation suggests that higher organisms have evolved to incorporate the phenylalanine instead of the leucine in the YF motif, and subsequently introduced the sulfiredoxin or sestrin gene.

Sestrins, in contrast to Srx, are only present in multicellular organisms ranging from nematodes to mammals. Vertebrates generally have only one Srx gene and multiple isoforms of sestrins. There are, however, organisms that contain hyperoxidizable, typical 2-Cys Prxs, but do not contain a Prx repair protein. The tryparedoxin-dependent peroxidases in kinetoplastida are one example. This

apparent anomaly may be due to the high concentration of Prxs, in *Crithidia fasciculata* at least, amounting to more than 5% of the soluble protein (Nogoceke *et al.*, 1997). *Caenorhabditis elegans* represents an organism that does not contain Srx but has a sestrin gene. *C. elegans* has two typical 2-Cys Prxs, CePrxI and CePrxII, where CePrxI is mitochondrial. Since mitochondrial Prx repair has yet to be reported, CeSestrin would only repair CePrxII. However, CePrxII expression is limited to two distinct neurons, I2 and I4, suggesting a very specific role for hyperoxidation and repair (Isermann *et al.*, 2004).

#### 4.2. Tissue Distribution

Typical 2-Cys Prxs in rat and human are abundant proteins constituting approximately 0.1–1% of soluble proteins in most tissue and cell lines (Chae *et al.*, 1999). For example, the highest concentration of PrxII is found in red blood cells ( $5 \text{ mg ml}^{-1}$ ) (Moore *et al.*, 1991). Srx appears to be a ubiquitous protein with large differences in concentration among tissues, suggesting that the level of Srx may be an indicator of the oxidative stress response. A higher abundance of Srx is observed in brain, colon, liver, spleen and spinal cord (Chang *et al.*, 2004). In *Arabidopsis* both the typical 2-Cys Prx and Srx are located in the chloroplast (Dietz *et al.*, 2006; Liu *et al.*, 2006). Northern blot analysis suggests that sestrin 1 is widely expressed in human tissues (Velasco-Miguel *et al.*, 1999). In this study the highest mRNA levels were seen in skeletal muscles. The substrate specificity and subcellular distribution of the sestrins are, however, not known.

#### 4.3. Conservation of Srx

A recent BLAST search using the human Srx (hSrx) sequence revealed the presence of Srx in organisms ranging from cyanobacterium and baker's yeast to human (representative alignment in Fig. 2) with at least 30% sequence identity. The active site motif GCHR containing the catalytic Cys99 (human numbering scheme) is strictly conserved. The alignment suggests that the Srxs vary predominantly at their N-termini. The plant *Arabidopsis thaliana* contains a N-terminal targeting sequence for the chloroplast (Liu *et al.*, 2006). Human Srx contains a glycine-rich sequence (35%; 13 of 37 residues) that is readily removed by limited tryptic digest and leaves the remainder of the protein intact and active (Jönsson *et al.*, 2005). This truncated form of hSrx approaches the size of *Nostoc* Srx (species PCC7120) that contains only 87 amino acids and represents the minimal catalytic core needed for sulfinic acid reductase activity. It is at the present moment unclear if the extended N-termini of human, rat and *Drosophila* Srx have a particular function. Interestingly, *S. cerevisiae*, which lacks most of the N-terminal extension, has numerous inserts between structurally conserved regions. A recent report suggests that Srx has sequence and structural similarity to a functionally unrelated protein ParB, a DNA binding protein involved in chromosome partitioning in bacteria (Basu

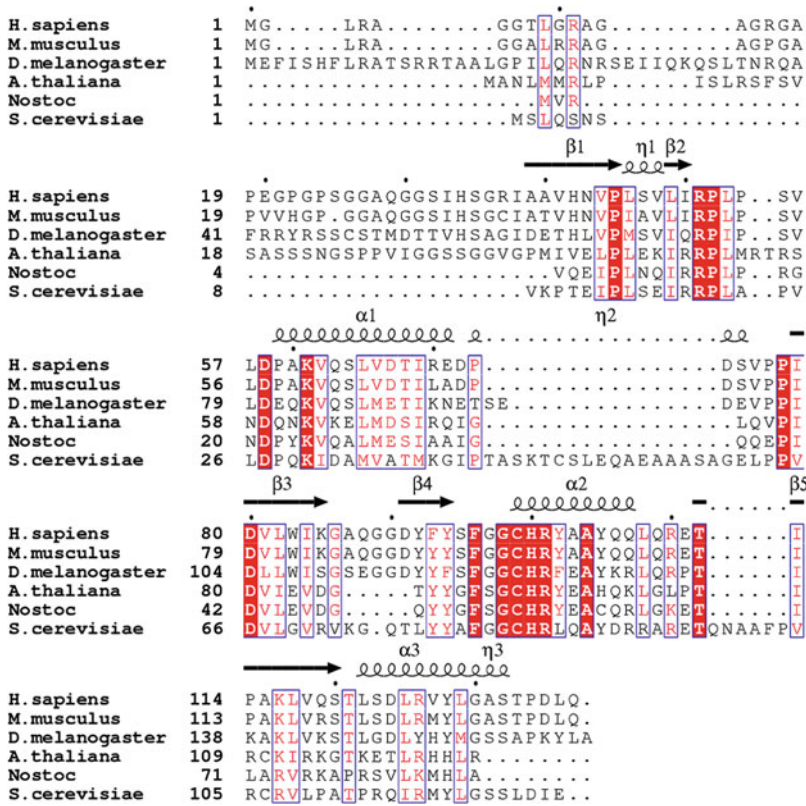

Figure 2. Sequence alignment of representative sulfiredoxins. The homology of the proteins to human Srx decreases down the alignment. The Srxs from mouse, *Drosophila*, *Arabidopsis*, *Nostoc* species PCC7120 (a cyano-bacterium), and *S. cerevisiae* show 91%, 60%, 43%, 41%, 33% sequence identity to hSrx, respectively. The secondary structural elements for human Srx are shown above the alignment:  $\alpha$ ,  $\alpha$ -helices;  $\beta$ ,  $\beta$ -strands;  $\eta$ , 3<sub>10</sub> helices (See Figure 3 and section 5.1). The residues highlighted by the red background and white lettering are strictly conserved. Residues that are either conserved in the majority of the proteins or have conservative substitutions are boxed in blue and colored red. The black dots above the alignment indicate every tenth residue of human Srx (See Plate 10)

*et al.*, 2005). Human Srx, however, shows no structural similarity to ParB (Jönsson *et al.*, 2005).

## 5. STRUCTURE OF SULFIREDOXIN AND PUTATIVE INTERACTIONS WITH PRXS

In an effort to understand the molecular basis for the novel sulfur chemistry mediated by Srx and the Srx:Prx interaction, the structure of human Srx has been determined by X-ray crystallography and NMR (PDB codes 1XW3, 1XW4, and 1YZS) (Jönsson *et al.*, 2005; Lee *et al.*, 2005). These structures have revealed a unique protein

fold and nucleotide-binding motif. These studies have also laid the foundation for future structural work and the biochemical characterization of site-directed mutants to investigate the role of Srx residues in Prx recognition and the retroreduction process. It is clear that significant structural rearrangements are required within the Prx molecule in order for Srx to access the Cys sulfinic acid moiety. Given the symmetry relationships of the Prx molecule and an analysis of the Srx surface features, a binding mode for Srx has been proposed.

### 5.1. Novel Protein Fold and Nucleotide-binding Motif

The peptide backbone which represents the overall fold of hSrx (Fig. 3A) has considerable agreement between the crystallographic and NMR structures (RMSD of C<sub>α</sub> carbon superposition of residues 38–137 is 1.1 Å). This “core” of Srx corresponds to the conserved region of Srx among different species (Fig. 2). The conformational differences in the N-terminal portion of the models are consistent with lower sequence homology across species and how these experimental techniques observe structural plasticity. For example, residues 29–37 in the 1.65 Å X-ray structure are most likely only visible as a consequence of the formation of a novel crystal contact involving the same region from two other Srx molecules (Jönsson *et al.*, 2005).

The N-terminus of Srx leads into a five-stranded, anti-parallel β-sheet (Fig. 3A) (Jönsson *et al.*, 2005). Three α-helices generate a curved surface with helix α2 and α3 located on opposite sides of the β-sheet. Helix α2 and the surrounding coil structures contain the signature sequence for Srxs, Gly98-Cys99-His100-Arg101 (Fig. 2). This motif in the native structure of human Srx coordinates through multiple hydrogen bonding interactions a phosphate ion present in the crystallization buffer. Arg51 is located adjacent to Cys99 (Fig. 3B) and most likely functions to activate Cys99 as the nucleophile of the reaction as originally proposed (Fig. 1). Several water molecules were also found in the vicinity interacting only with the phosphate ion.

In order to understand how ATP binds to the human Srx surface, crystals of the native enzyme were equilibrated with a solution containing 200 mM ADP. The 2.0 Å structure revealed that the β-phosphate group of ADP replaced the phosphate ion seen in the native structure. Similar interactions to His100 and Arg101 were observed. Lys61, also a conserved residue, was found to hydrogen bond to an oxygen atom of the α-phosphate group. The only other hydrogen bonds to ADP were from Ser64 and Thr68 to the adenine ring which fits into a shallow surface depression. As a whole these interactions represent a novel nucleotide-binding motif (Traut, 1994). Somewhat surprisingly, no hydrogen bonds were observed to the oxygen atoms of the ribose ring.

A model of the ATP:Srx complex (Fig. 3B) was generated using the ADP structure. In this model the γ-phosphate hydrogen bonds to the amide nitrogen atom of Gly98 and is positioned just above Cys99. Adjacent to the nucleotide binding site are two other pockets (Fig. 3C) that presumably provide contacts to the Prx

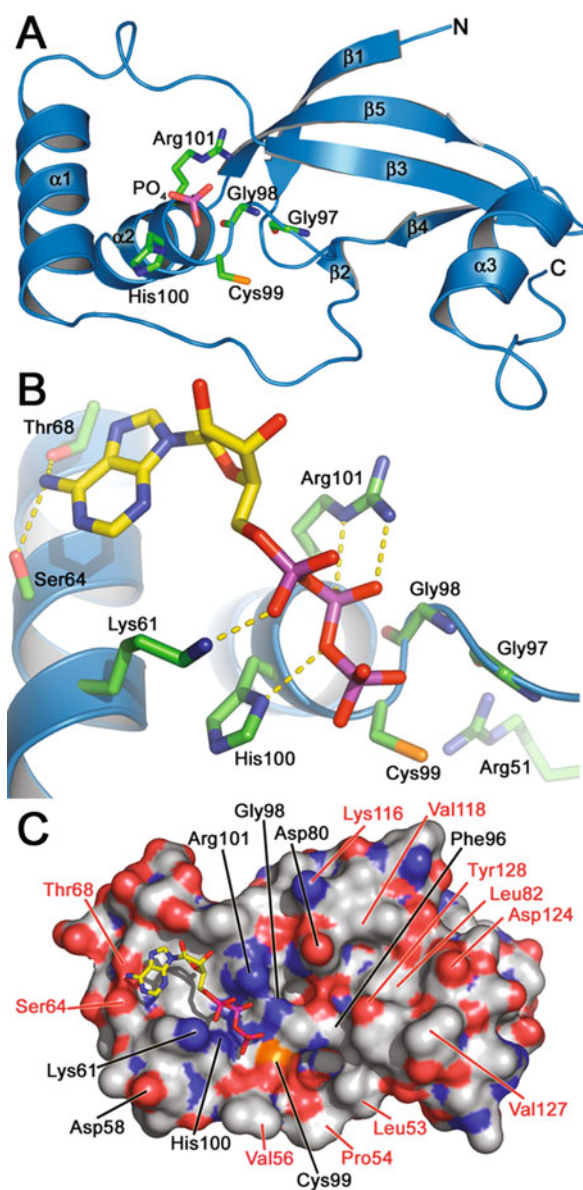

**Figure 3.** Crystal structure of human SrX. (A) Native enzyme in complex with phosphate. The  $\alpha$ -helices and  $\beta$ -strands within the novel fold of SrX are numbered consecutively based on the primary sequence. Residues of the signature sequence of SrX are highlighted. For clarity residues 29–36 and the  $3_{10}$ -helices are not shown. Atom color scheme: green, carbon atoms for SrX; yellow, carbon atoms for ATP; red, oxygen; blue, nitrogen; magenta, phosphorus; orange, sulfur. (B) Model of ATP bound to SrX. The ATP:Srx complex is based on the crystal structure of the ADP complex. Putative hydrogen bonding interactions are indicated by dashed yellow lines. (C) Surface representation of SrX in complex with ATP. Strictly and semi-conserved residues are indicated in black and red, respectively. Carbon atoms for the SrX surface are shown in gray (See Plate 11)



decameric structure. These pockets contain many conserved and semi-conserved residues including Leu53, Pro54, Val56, Asp80, Leu82, Phe96, Lys116, Asp124, and Tyr128. As described in more detail in section 6.2, site-directed mutants have been analyzed for some of these residues further supporting their role in mediating contacts with the Prx molecule. The ATP:Srx model and the biochemical data from yeast and human Srx available at that time suggested that the Srx reaction begins with the attack of the Prx-Cys-S<sub>p</sub>O<sub>2</sub><sup>-</sup> group onto the  $\gamma$ -phosphate of ATP (Fig. 4). Lys61, Gly98, His100, and Arg101 play key roles in holding the ATP molecule in the correct register for catalysis. His100 may also function to stabilize the developing negative charge on the oxygen atom that bridges the  $\beta$ - and  $\gamma$ -phosphates (Jönsson *et al.*, 2005).

A survey of the literature and other nucleotide- and phosphate-binding proteins, however, suggests some potential similarities to DNA ligases and protein tyrosine phosphatases despite little structural similarity between the folds of the proteins. For example, ATP- and NAD-dependent DNA ligases utilize a conserved Lys residue that becomes adenylylated (Timson *et al.*, 2000; Martin *et al.*, 2002). The presence of the Lys61- $\alpha$ -phosphate hydrogen bond in Srx is reminiscent of this type of interaction. However, HPLC analysis of the reactions products has confirmed that ATP hydrolysis occurs at the  $\beta$ - $\gamma$  phosphodiester bond thus excluding the potential adenylylated reaction intermediate. Moreover, the Cys99Ser mutant and the alkylated, wild-type enzyme are not able to facilitate ATP hydrolysis or the repair of the Prx molecule (Jönsson *et al.*, 2005). This latter finding coupled with the structural similarity to protein tyrosine phosphatases (e.g. PTP1B) (Pannifer *et al.*, 1998) suggests yet another putative intermediate, the phosphorylated form of Srx. In this comparison both Srx and PTP1B contain a conserved Arg residue within a phosphate-binding motif adjacent to an essential Cys residue. An analysis of the

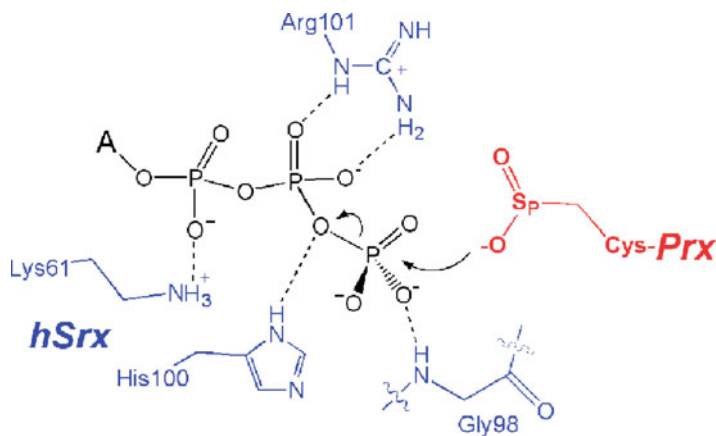
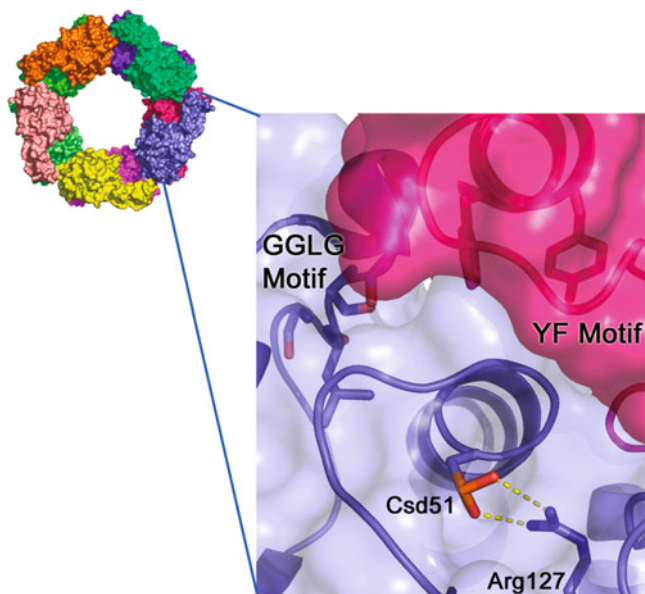

Figure 4. Proposed binding mode of ATP and the first step in the Srx reaction. Putative hydrogen bonding interactions are indicated by dashed lines. The nucleotide and sugar structures of the ATP molecule are abbreviated by the letter A (See Plate 12)

geometry of the ATP molecule and its relationship to Cys99 in the ATP:Srx model, however, suggests that an inline attack of the  $\gamma$ -phosphate, like that seen in PTP1B, would require significant movement of the ATP molecule, Srx or both. Nonetheless, as described in section 6.3, the analysis of site-directed mutants provides some evidence for this intermediate and suggests that the originally proposed reaction scheme may require some modification.

## 5.2. Model for the Interaction of Srx with Prx

A comparison of the crystal structure of human PrxII in the hyperoxidized state to the structures of other Prxs in a variety of oxidation states has revealed several structural motifs (Schröder *et al.*, 2000; Wood *et al.* 2003). These include the juxtaposition of the GGLG and YF motifs and the establishment of hydrogen bonds between the Cys51-S<sub>p</sub>O<sub>2</sub><sup>-</sup> moiety (Csd51 in Fig. 5) and Arg127, a conserved residue. These structural features occlude the active site for repair and therefore must be displaced or rearranged in order for Srx to perform its function.



*Figure 5.* Inaccessibility of the hyperoxidized active site of human PrxII. Hyperoxidized 2-Cys Prxs form stabilized decamers. Each monomer is colored differently. A close-up view of one PrxII active sites (blue surface and ribbon) illustrates the difficulty Srx has in gaining access to the Cys51-S<sub>p</sub>O<sub>2</sub><sup>-</sup> moiety (Csd51) which is involved in a hydrogen bonding interaction with Arg127. The Prx active site is occluded primarily by residues of the YF motif within the C-terminal  $\alpha$ -helix of the adjacent Prx molecule (magenta surface and ribbon). This latter structural feature also interacts with the GGLG motif, another conserved region found primarily in Prxs sensitive to hyperoxidation (See Plate 13)

These conformational changes are quite reasonable given the known flexibility of the C-terminal amino acids and the local unfolding of the helix containing the Cys-S<sub>p</sub>H residue required for normal Prx peroxidase activity (Wood *et al.*, 2003; see also Chapters 3 and 4). As described previously, it is the presence of the GGLG and YF motifs that make the eukaryotic, 2-Cys Prxs susceptible to hyperoxidation.

Based on the above discussion and the symmetry and proportions of the PrxII decamer and Srx, it is evident that one Srx molecule could bind to each Prx molecule once the active site has been exposed. Srx most likely binds such that its narrow dimensions are adjacent to each other with the  $\alpha 1$  and  $\alpha 3$  helices acting as molecular calipers. The top panel in Fig. 6 shows the “edge on” view of four subunits of the Prx decamer. The active sites of the middle Prx dimer are located on the periphery of the molecule and related by a two-fold symmetry axis. Srx could bind or dock to the circumference of the Prx decamer (Fig. 6, bottom panel). As described above, in order for Srx to access the Cys sulfinic acid moiety of one monomer of a Prx dimer, the C-terminal YF motif and associated helix from the adjacent monomer must move out of the way. It is unclear if Srx actively facilitates this process. It has been suggested that the conserved Asp80 residue, predominately located on the Srx surface (Fig. 3C), could disrupt the Cys51(Csd51)-Arg127 interaction of PrxII (Jönsson *et al.*, 2005). Additional surface residues of Srx undoubtedly play a role as indicated by the mutagenesis studies described in section 6.2.

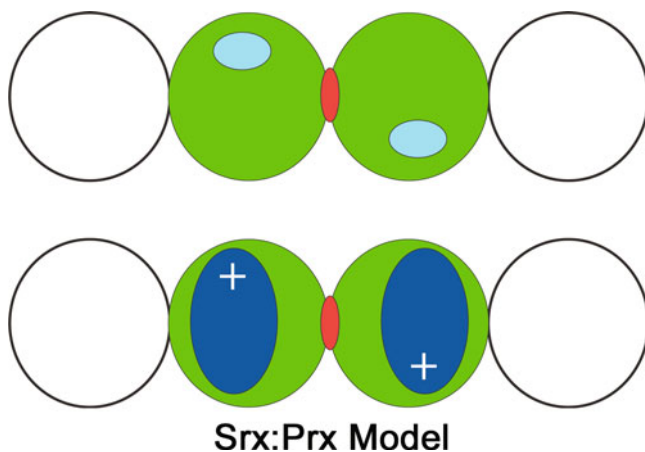

*Figure 6.* Model for the Srx:Prx interaction. The top panel indicates the edge-on view of four subunits of a Prx decamer. The active sites of the middle Prx dimer (green) are indicated in cyan. The two-fold axis is indicated by the red dyad symbol. Adjacent subunits in the Prx decamer are shown as the non-filled circles. The bottom panel illustrates the putative binding mode of Srx (blue) to the circumference of the decamer and the central Prx dimer. The Srx molecules most likely also adopt a two-fold relationship indicated by the plus signs. It is possible that the Srx molecules dock more to the side of the Prx decamer maintaining the symmetry relationship (See Plate 14)

## 6. CATALYTIC PROPERTIES OF SRX

Since the initial characterization of yeast Srx1 and the determination of the human Srx structure, several studies have provided further insight into the catalytic mechanism and substrate specificity of human and rat Srx. In these studies three activity assays have been utilized: (i) sulfinic acid reductase activity based on the decrease in the immuno-reactive band to Prx-SO<sub>2/3</sub><sup>-</sup>, (ii) ATPase activity corresponding to the increase in the amount of inorganic phosphate released, (iii) binding of Srx to Prx using the Srx-GST fusion and GSH-sepharose (Woo *et al.*, 2003; Chang *et al.*, 2004; Woo *et al.*, 2005; Jeong *et al.*, 2006). The results from these studies suggest that the initial steps in the reaction may need to be reconsidered and evaluated by further experimentation.

### 6.1. Cofactor Requirements and Catalytic Efficiency

Woo *et al.* set out to improve upon the AMS method for monitoring the sulfinic acid reductase activity of Srx by generating an antibody specific for Prx – SO<sub>2/3</sub><sup>-</sup> (Woo *et al.*, 2003). With this method the decrease in the sulfinic acid form of hPrxI was monitored over time following treatment with the recombinant forms of rat, mouse, and human Srx. All Srx variants exhibited the same specific activity in the presence or absence of an N-terminal GST affinity tag (Chang *et al.*, 2004). Moreover, Srx purified from A549 human lung epithelial cells had the same specific activity. A screen of a panel of electron donors (DTT, glutathione, *E. coli* Trx1, Trp14 and SpTrx) indicated that glutathione (GSH) and Trx are most likely the *in vivo* reductants. The apparent K<sub>M</sub> values for GSH and Trx1 were 1.8 mM and 1.2 μM, respectively, when 5 μM human PrxI-SO<sub>2</sub><sup>-</sup> was used as the substrate in the assay. The *k*<sub>cat</sub> value was estimated to be between 0.1–0.18 min<sup>-1</sup>, thus Srx is an inefficient enzyme. The pK<sub>a</sub> of Cys99 of hSrx was also determined to be ~ 7.3 which is consistent with its proposed function as a nucleophile under physiological conditions.

The nucleotide dependence of the rat Srx reaction was investigated further by testing ATP, GTP, AMP-PNP, ADP, CTP, UTP, dATP, dGTP, dCTP, and dUTP. Reduction was supported with ATP and GTP in both nucleotide forms, but not ADP, AMP-PNP as expected. Activity with CTP, UTP, and the corresponding deoxyribonucleotide forms were significantly lower. Using saturating concentrations of Srx and PrxI-SO<sub>2</sub><sup>-</sup>, the apparent K<sub>M</sub> for ATP was determined to be 30 μM. In a subsequent study the K<sub>d</sub> for ATP was determined to be ~ 6 μM by monitoring the change in the intrinsic fluorescence emission spectra for wild-type and the C99S variant of human Srx (Jeong *et al.*, 2006).

### 6.2. Substrate Specificity and Mutational Analysis

Several lines of evidence support the selective binding of typical 2-Cys Prxs by Srx (Woo *et al.*, 2005): (i) the GST-Srx fusion protein can bind the reduced and oxidized forms of PrxI-IV from HeLa cells with and without H<sub>2</sub>O<sub>2</sub> treatment, but

not the atypical 2-Cys PrxV or the 1-Cys PrxVI; (ii) reduced hPrxI can compete for hyperoxidized hPrxI in the reductase antibody assay; (iii) a yeast two-hybrid screen indicated interactions only between Srx and PrxI-IV; and (iv) overexpression of Srx in A549 cells reduces the levels of hyperoxidized PrxI-IV upon H<sub>2</sub>O<sub>2</sub> treatment, but not the other Prxs or glyceraldehyde-3-phosphate dehydrogenase (GAPDH). Activity analyses using recombinant PrxI-6 have further confirmed that only the typical 2-Cys PrxI-IV are reduced. Moreover, Srx is not able to repair the sulfinic acid form of GAPDH. It is important to note here that while Srx can repair PrxI-IV *in vitro*, Srx most likely only repairs PrxI and PrxII since both molecules are localized to the cytosol (Chang *et al.*, 2004). In contrast, PrxIII and PrxIV are located in the mitochondria and the extracellular space, respectively. Interestingly, PrxVI and GAPDH are located in the cytosol and are not reduced by Srx. Based on this analysis it is possible that the sestrins are responsible for the repair of the other Prx isozymes and other proteins. Another possibility is that the hyperoxidation of some proteins is irreversible (Woo *et al.*, 2005).

The structure of human Srx and sequence alignments have enabled the design of site-directed mutagenesis experiments to evaluate the role of conserved residues in Prx binding and Srx catalysis. Six conserved, charged amino acids were assessed by making the following mutations in rat Srx (rSrx): Arg51Met, Asp58Asn, Lys61Arg, Asp80Asn, His100Asn, Arg101Met (Jeong *et al.*, 2006). For ease of comparison, the residue numbers correspond to hSrx; numbers in rSrx are lower by one. The Asp67Ala and Ser75Ala variants were also generated, but these residues are only conserved in mammalian Srxs. The GST-fusion form of each rSrx variant was tested for its ability to bind to either recombinant PrxI or PrxI from HeLa cell extracts using the GSH-sepharose pulldown method. The Arg51Met and Asp80Asn mutants were unable to bind PrxI. The Asp58Asn variant exhibited reduced binding while the remaining mutants were similar to wild-type rSrx. The decreased binding ability of the Asp58 and Asp80 variants is consistent with their presence on the surface of hSrx near the ATP binding site (Fig. 3C). The Arg51 variant is more difficult to interpret since it is not on the surface of hSrx. One possibility for this finding is that the hydrogen bond between Arg51 and the carbonyl oxygen of Gly98 stabilizes the Gly-Gly component of the FGGCHR active site motif.

The panel of rSrx mutants was also assessed for their ability to stimulate ATP hydrolysis and Cys sulfinic acid reduction. A marked loss in both activities was observed for all residues that contact the ATP molecule; Lys61, His100, Arg101 (Fig. 3B). The mutation of Cys99, Arg51 and Asp80 also lead to a reduction in both activities. The loss in activity for Cys99 is consistent with the inactivity of the Cys84Ser mutant of yeast Tsa1 (Biteau *et al.*, 2003). The decrease in activity for the Arg51 mutation is the result of either the loss of active site stabilization described above or the decreased activation of Cys99 to act as the nucleophile in the reaction (Jönsson *et al.*, 2005). The diminished activity for the Asp80 variant suggests that this residue may play a key role in the Prx:Srx interaction in contrast to the other surface residues tested (i.e. Asp58, Asp67, and Ser75) which showed wild-type levels of activity (Jeong *et al.*, 2006).

### 6.3. Exploring the Reaction Mechanism

The original reaction mechanism proposed for yeast Srx1 (Fig. 1 and Fig. 7, Path 1) was based on the requirements for ATP/Mg<sup>2+</sup> and the formation of DTT-reducible complex between Srx1 and Tsa1. Sulfinic phosphoryl ester and thiosulfinate intermediates were proposed to be formed. In this scheme Srx would function as a phosphotransferase (Path 1, Step 1) and a thioltransferase (Path 1, Step 2) (Biteau *et al.*, 2003). Support for this reaction scheme came from the structure of hSrx in complex with ADP and an ATP model (Fig. 3). In these models the  $\gamma$ -phosphate of ATP is near Cys99, but does not directly interact. Based on these observations it has been proposed that the sulfinic acid group of Prx directly attacks the  $\gamma$ -phosphate yielding the sulfinic phosphoryl ester intermediate (Jönsson *et al.*, 2005). In this proposal it is not clear why the thiolate of Cys99, most likely generated by its interaction with Arg51, is essential for the first step of the reaction.

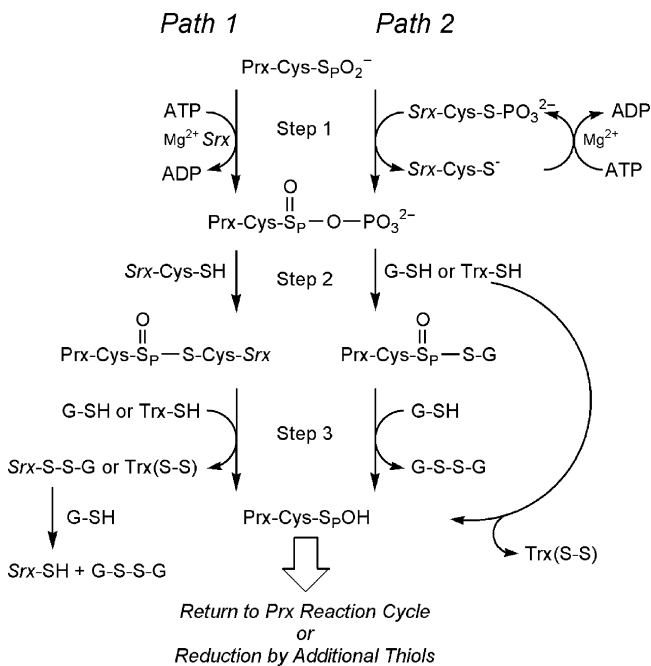

*Figure 7.* Comparison of the proposed reaction mechanisms for Srx. Path 1 represents the original mechanism as proposed for yeast Srx1. Path 2 incorporates potential modifications to the reaction pathway based on biochemical experiments with mammalian Srxs in both the wild-type and mutant forms. Step 1 involves the formation of the sulfinic phosphoryl ester intermediate. In step 2 of the reaction, the addition of a thiol group leads to the formation of alternative thiosulfinate intermediates. Breakdown of the latter intermediate occurs in steps 3 and following via reduction by additional thiol-disulfide exchange reactions

Efforts to detect the proposed sulfinic phosphoryl ester intermediate from reactions containing hPrxI-SO<sub>2</sub><sup>-</sup>, [ $\gamma$ -<sup>32</sup>P]ATP, hSrx, and reducing agents by immunoprecipitation, SDS-PAGE, and autoradiography have not been successful (Jeong *et al.*, 2006). One possibility for this outcome is that the formation of the thiosulfinate intermediate in the original mechanistic proposal (Path 1, Step 2) with Srx is too fast. Therefore, Jeong *et al.* rationalized that the phosphorylated intermediate may be stabilized by mutating Cys99 to Ser, a mutation as described earlier that results in the inactive form of hSrx. Even though the Cys99Ser mutant and wild-type hSrx exhibit similar affinities for ATP (~6  $\mu$ M), the phosphorylated Prx intermediate was not observed. In contrast, phosphorylation of Ser99 of hSrx was found in < 1% of the sample after four hours incubation. Interestingly, the reduced form of PrxI was not able to induce the phosphorylation of Ser99. These findings suggest that the sulfinic acid group on Prx is necessary for phosphorylation to occur. Moreover, Cys99 of hSrx may be phosphorylated by ATP first followed by transfer of the phosphate group to the sulfinic acid moiety of Prx (Path 2, Step 1) yielding the same phosphoryl ester intermediate formed in Path 1.

ATP hydrolysis was analyzed further by monitoring the time-dependent release of P<sub>i</sub> as a function of the presence and absence of a reductant, and the hSrx and hPrxI-SO<sub>2</sub><sup>-</sup> concentrations (Jeong *et al.*, 2006). In the presence of GSH, Trx and DTT, the amount of P<sub>i</sub> released is proportional to the amount of Prx-SO<sub>2</sub><sup>-</sup> in the reaction. If a reductant is not added, the amount of P<sub>i</sub> released is several fold greater than the amount of hyperoxidized Prx in the reaction. Based on these findings, the authors of this study suggested that the extra P<sub>i</sub> released comes from a futile cycle between the sulfinic phosphoryl ester intermediate and its collapse back to the sulfinic acid group. The extra P<sub>i</sub> released is thought not to come from the hydrolysis of the Cys99-S-PO<sub>3</sub><sup>2-</sup> intermediate (Path 2, Step 1) since this route would be unable to account for the observed GSH dependence. Since there was no apparent difference in the rates of sulfinic acid reduction by either GSH, DTT or Trx *in vitro*, it was also proposed that the sulfinic phosphoryl intermediate is fully accessible and reacts readily to form a thiosulfinate intermediate with GSH or Trx *in vivo* (Path 2, Step 2). The resulting thiosulfinate intermediates for Paths 1 and 2 would then be further reduced (Step 3 and following) by thiol equivalents from the second Cys residue present in Trx (e.g. Cys35 in eTrx) or additional GSH molecules. It should be noted, however, that an excess of P<sub>i</sub> release would also be predicted for Step 1 of Path 1 if the most inefficient step of the reaction is the attack of Cys99 onto the sulfinic phosphoryl ester intermediate.

One other aspect of the Srx:Prx interaction has been investigated: the apparent ability of the proteins to form disulfide-bonded intermediates *in vitro* and *in vivo*. Yeast Srx1 and Tsa1 isolated from cells formed oligomers that were sensitive to DTT treatment (Biteau *et al.*, 2003). This observation suggested as described previously that the Srx reaction progressed through a thiosulfinate intermediate. One other possibility is that these complexes actually contain a disulfide bond between the two molecules. Evidence for this proposal has been obtained from the analysis of mixtures containing the recombinant proteins. In these analyses a disulfide bond

was established by mass spectrometry (Jeong *et al.*, 2006; Jönsson and Lowther, unpublished results). In the presence of the hyperoxidized PrxI, a disulfide was found between PrxI-Cys52, the peroxidatic Cys, and Cys99 of hSrx. When reduced PrxI was used in the Rhee laboratory, a Srx:Prx complex was also found to be mediated between Cys99 and Cys173, the resolving Cys residue. It is unclear at this time how these intermediates fit, if at all, into the sulfinic acid reductase mechanism of Srx. It is not surprising, however, that disulfide intermediates can be trapped since once the sulfinic acid group of the Prx molecule has been repaired to the sulfenic acid moiety, this latter group can readily react with adjacent thiols. Cys99 of hSrx would be a prime candidate for such a reaction.

## 7. IMPORTANCE OF SRX IN CELL SIGNALLING AND DEFENSE

Intracellular levels of peroxide are tightly regulated and kept at nM levels (Seaver *et al.*, 2001). In contrast to bacteria where peroxide generally is viewed as toxic and rapidly eliminated, higher organisms utilize intermediate levels of peroxide in cell signaling (Rhee, 2006). In an effort to designate a cellular role for the hyperoxidation of typical 2-Cys peroxidase in cell signaling, the “floodgate” hypothesis was proposed (Wood *et al.*, 2003). In this proposal the Prx molecule and its enzymatic activity constitute a wall that prevents peroxide to reach peroxide-sensitive targets. Elevated levels of peroxide, however, would promote Prx hyperoxidation and allow peroxide to breach the wall enabling the activation or inactivation of key targets. The interplay between heme/thiol/selenium-dependent peroxidases, peroxide levels, and the hyperoxidation of typical Prxs is currently an area of investigation. In contrast to the floodgate model, evidence is also accumulating which suggests that typical 2-Cys Prxs work as a peroxide dosimeter. In this scenario the formation of hyperoxidized Prx is itself an oxidative stress signal that can be turned off by the reduction or repair of the sulfinic acid group. We are currently in the early stages of understanding the role of the Prx-sulfinic acid switch in oxidative stress-mediated signaling.

### 7.1. Prx-dependent Peroxide Sensing in *Schizosaccharomyces pombe*

In the yeast *S. pombe* at least two independent pathways have evolved to respond to different levels of H<sub>2</sub>O<sub>2</sub>: the Pap1 and Sty1 pathways. Pap1 is an AP-1-like transcription factor that under normal conditions associates with the nuclear export factor Crm1 in the cytoplasm (Toone *et al.*, 1998). Sty1 is a mitogen-activated protein kinase (MAPK) that is known to phosphorylate the transcription factor Atf1 (Shiozaki *et al.*, 1995; Degols *et al.*, 1996; Shiozaki *et al.*, 1996; Wilkinson *et al.*, 1996). Under stress conditions with low levels of H<sub>2</sub>O<sub>2</sub>, Pap1 is activated by the formation of an intramolecular disulfide bond that prevents association with Crm1 and results in the nuclear accumulation (Toone *et al.*, 1998; Kudo *et al.*, 1999; Castillo *et al.*, 2002; Quinn *et al.*, 2002). In contrast, elevated levels of peroxide prevent nuclear accumulation and the expression of Pap1-dependent genes (Quinn



*et al.*, 2002; Vivancos *et al.*, 2004). Sty1 and Aft1 are also activated at elevated levels of peroxide (Quinn *et al.*, 2002).

It was until recently unclear how these disparate pathways are activated in *S. pombe*. The reversibility of the peroxide-sensitive inactivation of typical 2-Cys Prx and the subsequent discovery of Srx in yeast suggested a potential role for Prx in peroxide sensing in *S. pombe*. Two different groups, the Morgan and Hidalgo laboratories, simultaneously showed that at low levels of H<sub>2</sub>O<sub>2</sub> (0.2 mM) Pap1 became oxidized, i.e. the disulfide-bonded form, within 5 min and accumulated in the nucleus. With high levels of H<sub>2</sub>O<sub>2</sub> (1 mM) Pap1 did not become oxidized until 30 minutes after treatment (Bozonet *et al.*, 2005; Vivancos *et al.*, 2005). When the TPx1 gene was knocked out, however, Pap1 remained reduced in the cytosol independent of the peroxide levels. This observation suggests that TPx1 could transfer a redox signal to Pap1. In contrast, two other thiol peroxidases, Gpx1 and Pmp20, did not influence the oxidation status of Pap1. Rapid hyperoxidation of TPx1 was seen at the high level of peroxide treatment which after one hour returned to the reduced form. This time-dependent repair of TPx1 correlated with the delayed oxidation of Pap1. Consistent with these observations, TPx1 in cells lacking Srx stayed in the Cys-SO<sub>2</sub><sup>-</sup> form after the peroxide insult and more importantly Pap1 remained reduced. These studies suggested that reduced TPx1, but not hyperoxidized TPx1, was involved in introducing a disulfide bond in Pap1. Studies on cysteine mutants in TPx1 and Pap1 suggested that a disulfide bond between TPx1 and Pap1 could be formed when the resolving cysteine, Cys169, was mutated in TPx1. However, this complex was never able to promote a disulfide bond in Pap1, suggesting that further factors are important in mediating oxidation of Pap1.

The observation that Sty1 and Aft1 are activated at elevated levels of peroxide led investigators to look at the role of this pathway in the Pap1/TPx1 relay (Bozonet *et al.*, 2005; Vivancos *et al.*, 2005). In cells lacking Sty1, TPx1 accumulated in the hyperoxidized form after the addition of high levels of peroxide, suggesting that the Sty1 pathway activated Srx expression. Indeed, Srx expression was shown to be dependent on both Pap1 and Aft1, but Sty1 is essential at high peroxide levels. In a previous study Veal *et al.* showed that TPx1 at high peroxide levels can form a stable disulfide bond with Sty1 via the peroxidatic cysteine to promote Sty1 activation (Veal *et al.*, 2004). However, it is unclear to what extent this disulfide bond can be formed at high peroxide levels when TPx is rapidly undergoing hyperoxidation of the peroxidatic cysteine.

## 7.2. Src and Chloroplast Protection

2-Cys Prxs also detoxify peroxides within the chloroplast (Dietz *et al.*, 2002; König *et al.*, 2002). The chloroplast is the main source of ROS due to its role in photosynthesis and the synthesis of amino acids, fatty acids and nucleotides (Apel *et al.*, 2004). Given the importance of Prxs in plants, the molecular and functional characterization of *Arabidopsis* and rice Srx was investigated (Liu *et al.*, 2006). As shown in Fig. 2, *Arabidopsis* Srx (AtSrx) contains all the conserved residues

necessary for the binding of ATP and catalysis. The same characteristics are also found in a variety of other dicot and monocot plant species. Plant Srxs contain a putative chloroplast targeting peptide. AtSrx has been shown to co-localize with chlorophyll using C-terminal GFP fusion constructs *in vivo*. Moreover, AtSrx and rice Srx were able to complement the yeast Srx1 knockout thus enabling growth on media containing H<sub>2</sub>O<sub>2</sub>. All these observations suggest that plant Srxs may play a key role in the retroreduction of plant 2-Cys Prxs.

In an effort to characterize the function of Srx in plants, the transcriptional patterns of gene expression were determined during resting and stress conditions using semiquantitative PCR (Liu *et al.*, 2006). Under normal conditions the highest levels of Srx mRNA were observed in leaves and stems of *Arabidopsis*. The Srx transcript levels were dramatically increased upon treatment with H<sub>2</sub>O<sub>2</sub> (4 mM), polyethylene glycol 8000 (10 %) to induce dehydration, and cold (4 °C). Plants containing a T-DNA insert to inactivate the endogenous AtSrx were more susceptible to oxidative stress induced by 10 μM paraquat, as indicated by a chlorosis or bleaching phenotype. AtSrx reintroduced via an *Agrobacterium*-mediated transformation rescued the hypersensitive phenotype. Taken together the data suggest that plant Srxs provide a protective function under stress conditions by repairing hyperoxidized, 2-Cys peroxiredoxins. Further experiments are required to confirm that AtSrx can repair hyperoxidized Prxs *in vivo* and *in vitro* via either the Prx-SO<sub>2/3</sub><sup>-</sup> antibody or AMS assays.

### 7.3. Srx and Modulation of Prx Chaperone Function

The peroxidase activity of typical 2-Cys Prxs have been studied extensively *in vitro*, however, the *in vivo* significance of this activity is unknown. Studies in yeast have indicated that cells lacking cPrxI (TPxI) and cPrxII (TPxII) were more susceptible to heat shock. Surprisingly, the ΔcPrxI/II cells expressing the non-cysteine containing mutant Cys47/170Ser of cPrxI were more resistant to heat shock stress than the double knockout cell line. These observations suggest that cPrxI has a protective, non-peroxidatic activity (Jang *et al.*, 2004). *In vitro* studies with purified proteins showed that cPrxI was able to protect citrate synthase from thermal aggregation and insulin from DTT-dependent denaturation, leading the authors to propose that cPrxI has molecular chaperone activity. Similar to many other molecular chaperones cPrxI was shown to exist in complexes ranging from 40 to 1000 kDa. Analysis of the different molecular weight species showed that: (i) the high molecular weight (HMW) complexes had chaperone activity, but no peroxidase activity; (ii) the low molecular weight complexes (LMW) had peroxidase activity, but no chaperone activity; and (iii) increasing the temperature promotes formation of HMW species. In addition, hyperoxidized cPrxI predominantly formed HMW complexes. Therefore, Prx-SO<sub>2</sub><sup>-</sup> formation may be important in promoting molecular chaperone activity in the cell.

In order to demonstrate the peroxidase-to-chaperone functional switch *in vivo*, yeast cells were exposed to various stresses (Jang *et al.*, 2004). Wild-type cells showed greater survival rates than  $\Delta$ cPrxI/II knock out cells under heat stress. Wild-type cells were also shown to promote the formation of HMW complexes concomitant with the increased intracellular levels of reactive oxygen species as judged by DCF staining. The addition of 0.5 mM peroxide shifted cPrxI from LMW to HMW complexes which correlated with the formation of hyperoxidized cPrxI. However, after 20 minutes of recovery, cPrxI-SO<sub>2</sub><sup>-</sup> was repaired and the HMW species reverted to LMW species. Yeast lacking Srx were unable to repair cPrxI-SO<sub>2</sub><sup>-</sup> after H<sub>2</sub>O<sub>2</sub> exposure and only HMW species were observed. Therefore, Srx appears to play a critical role in cell survival by regulating the beneficial functions of peroxidase activity versus chaperone activity of Prxs. In addition to the traditional toroid shaped decamer, EM studies of the HMW complexes also revealed large spherically-shaped particles which appeared to lack symmetry. The ability of Srx to access different oligomeric sizes of cPrxI and to promote their disruption and reduction is unclear.

Further studies by the Lee laboratory on recombinant, human PrxII showed that it can also function as a molecular chaperone by protecting citrate synthase, insulin and  $\alpha$ -synuclein from stress-induced aggregation (Moon *et al.*, 2005). As observed in yeast cPrxI, hPrxII was shown to exist in multiple forms of LMW species that upon peroxide treatment resulted in overoxidation and complete conversion into HMW complexes. Removal of the C-terminal helix containing the essential hyperoxidation YF-motif (Fig. 5) preserved the peroxide activity and prevented HMW species formation and chaperone function. In HeLa cells, exposure to 0.2 mM H<sub>2</sub>O<sub>2</sub> converted all of hPrxII to HMW complexes. After a 40 min recovery period the HMW complexes returned to LMW species. This data suggests a role for Srx or sestrin in terminating the Prx-dependent chaperone activity in HeLa cells as seen in the yeast system.

Human PrxI had previously been shown to be phosphorylated at Thr90 by Cdc2, a cyclin dependent kinase, during the mitotic phase of the cell cycle (Chang *et al.*, 2002). Studies on the recombinant analogue hPrxI-T90D which mimics phosphothreonine showed decreased peroxidase activity. It was hypothesized that the insertion of a charged moiety in close proximity to the hydrophobic dimer-dimer interfaces would promote disassociation of the decamer and thus decrease the peroxidase activity (Wood *et al.*, 2003). However, Jang *et al.* showed that the recombinant hPrxI-T90D mutant almost exclusively purified as HMW complexes (Jang *et al.*, 2006). In contrast to wild type hPrxI, the hPrxI-T90D exhibited reduced peroxidase activity and six-fold higher chaperone activity. The role of decreased peroxidase activity, increased chaperone activity, and the possible involvement of Srx repair in cell cycle regulation is at present unclear.

Given the connection between the formation of Prx-SO<sub>2</sub><sup>-</sup> and chaperone activity, the report by Chuang *et al.* which proposed that *H. pylori* AhpC can switch from a peroxide reductase to a molecular chaperone function under oxidative stress

was surprising (Chuang *et al.*, 2006). AhpC has not been shown to be substrate inactivated nor does it contain the essential YF-motif. Moreover, *H. pylori* lacks both Srx and sestrin genes. Harsh pre-treatment of recombinant AhpC with 10 mM H<sub>2</sub>O<sub>2</sub> for 12 hours may have resulted in the apparent loss of peroxidase activity and the gain of chaperone activity. *H. pylori* cells exposed to aerobic stress (20% O<sub>2</sub> rather than the normal 5%) forced AhpC to oligomerize into HMW species as seen in the human and yeast system. Unfortunately, the authors did not address whether Cys sulfenic acid was formed under these conditions. Thiol quantitation found no free thiols, however, suggesting that either a disulfide bond had been formed or both the resolving and peroxidatic cysteines had been hyperoxidized.

#### 7.4. Srx and (De)glutathionylation Phenomena

Another curious role of human Srx is to modulate the post-translational modification of proteins by glutathione. HEK293 cells stably transfected with the Srx gene show a significant reduction in the levels of protein glutathionylation after treatment with PABA/NO, a potent inducer of oxidative stress via the release of nitric oxide (Findlay *et al.*, 2006). In this study the level of glutathionylation was determined by Western blot analysis using an antibody specific for the protein-S-S-G linkage. In order to investigate this observation further, actin and PTP1B, known glutathionylation targets in cells, were treated *in vitro* with GSH and PABA/NO in the absence and presence of native and heat-inactivated, wild-type hSrx and the C99S mutant. In the absence of hSrx, both actin and PTP1B showed a time-dependent increase in glutathionylation. The presence of native and C99S Srx, however, led to a significant decrease in the protein modification. The addition of unfolded Srx resulted in the accumulation of glutathione adducts. Moreover, Srx was able to prevent the loss of the phosphatase activity of PTP1B upon PABA/NO treatment. These observations suggest that Srx can either prevent or reverse glutathionylation of a variety of proteins in a non-specific manner.

Two additional pieces of evidence suggest that hSrx does play a role in influencing glutathionylation levels *in vivo*. First, PABA/NO-treated, HEK293 cell extracts show a decreased level of adduct formation when treated with wild-type Srx *in vitro*, but not the C99S variant. Second, hSrx decreases the G/F-actin ratio leading to cell morphology changes. It is clear that more studies are needed in this area. For example, in order to confirm that Srx removes the glutathione moiety instead of protecting or blocking the site of glutathionylation, GSH adducts need to be formed in the absence of Srx, purified away from the PABA/NO and excess GSH, verified by mass spectrometry, and then treated with Srx. At the end of the incubation period with Srx, the glutathione protein target and Srx need to be reanalyzed by mass spectrometry to verify GSH removal or addition. It will also be important to assess whether this activity has the same cofactor requirements (ATP and Mg<sup>2+</sup>) as the sulfenic acid reductase activity. These initial studies suggest that Srx has therapeutic potential for a variety of diseases with aberrant protein glutathionylation (Findlay *et al.*, 2005; Findlay *et al.*, 2006).

## 8. CONCLUSIONS

The peroxide-dependent hyperoxidation of the typical 2-Cys Prxs and subsequent repair by Srx and sestrins is emerging as a unique response to severe oxidative stress. The signaling event attributed to this process is prolonged by the slow repair. It is entirely possible that the large conformational changes that must take place for Srx to access the Prx active site contribute to the inefficiency of the retroreduction process. In addition, the formation of the large hyperoxidized Prx chaperone complexes further impedes access of Srx to Prx. The peroxide-to-chaperone switch is one example of how the oligomeric state of Prx can influence cellular events. We suspect that redox-dependent conformational changes, and especially the formation of the sulfinic acid moiety, in Prx are important in discriminating their interactions with biological partners. It remains to be seen if Srx or sestrin has additional activities in addition to the sulfinic acid repair.

## ACKNOWLEDGEMENTS

The authors acknowledge the technical help of Lynnette C. Johnson and Michael S. Murray for his work in the determination of the crystal structure of human Srx. This work was supported by funds from the National Institutes of Health, U.S.A. (R01-GM072866 to W.T.L.)

## REFERENCES

- Apel, K., and Hirt, H., 2004, Reactive oxygen species: metabolism, oxidative stress, and signal transduction. *Annu. Rev. Plant Biol.* **55**: 373–399.
- Baker, L. M., Raudonikiene, A., Hoffman, P. S., and Poole, L. B., 2001, Essential thioredoxin-dependent peroxiredoxin system from *Helicobacter pylori*: genetic and kinetic characterization. *J. Bacteriol.* **183**: 1961–1973.
- Basu, M. K., and Koonin, E. V., 2005, Evolution of eukaryotic cysteine sulfinic acid reductase, sulfiredoxin (Srx), from bacterial chromosome partitioning protein ParB. *Cell Cycle.* **4**: 947–952.
- Biteau, B., Labarre, J., and Toledano, M. B., 2003, ATP-dependent reduction of cysteine-sulphinic acid by *S. cerevisiae* sulphiredoxin. *Nature.* **425**: 980–984.
- Bozonet, S. M., Findlay, V. J., Day, A. M., Cameron, J., Veal, E. A., and Morgan, B. A., 2005, Oxidation of a eukaryotic 2-Cys peroxiredoxin is a molecular switch controlling the transcriptional response to increasing levels of hydrogen peroxide. *J. Biol. Chem.* **280**: 23319–23327.
- Budanov, A. V., Sablina, A. A., Feinstein, E., Koonin, E. V., and Chumakov, P. M., 2004, Regeneration of peroxiredoxins by p53-regulated sestrins, homologs of bacterial AhpD. *Science.* **304**: 596–600.
- Budanov, A. V., Shoshani, T., Faerman, A., Zelin, E., Kamer, I., Kalinski, H., Gorodin, S., Fishman, A., Chajut, A., Einat, P., Skaliter, R., Gudkov, A. V., Chumakov, P. M., and Feinstein, E., 2002, Identification of a novel stress-responsive gene Hi95 involved in regulation of cell viability. *Oncogene.* **21**: 6017–6031.
- Budde, H., Flohé, L., Hecht, H. J., Hofmann, B., Stehr, M., Wissing, J., and Lünsdorf, H., 2003, Kinetics and redox-sensitive oligomerisation reveal negative subunit cooperativity in tryparedoxin peroxidase of *Trypanosoma brucei*. *Biol. Chem.* **384**: 619–633.
- Castillo, E. A., Ayte, J., Chiva, C., Moldon, A., Carrascal, M., Abian, J., Jones, N., and Hidalgo, E., 2002, Diethylmaleate activates the transcription factor Pap1 by covalent modification of critical cysteine residues. *Mol. Microbiol.* **45**: 243–254.

- Castro, H., Budde, H., Flohé, L., Hofmann, B., Lünsdorf, H., Wissing, J., and Tomas, A. M., 2002, Specificity and kinetics of a mitochondrial peroxiredoxin of *Leishmania infantum*. *Free Radic. Biol. Med.* **33**: 1563–1574.
- Cesaratto, L., Vascotto, C., D'Ambrosio, C., Scaloni, A., Baccarani, U., Paron, I., Damante, G., Calligaris, S., Quadrioglio, F., Tiribelli, C., and Tell, G., 2005, Overoxidation of peroxiredoxins as an immediate and sensitive marker of oxidative stress in HepG2 cells and its application to the redox effects induced by ischemia/reperfusion in human liver. *Free Radic. Res.* **39**: 255–268.
- Chae, H. J., Kim, K., and Kim, I. H., 1999, Redox Regulation of cell signaling and its clinical application, Marcel Dekker, Inc., New York, pp. 85–92.
- Chae, H. Z., Chung, S. J., and Rhee, S. G., 1994, Thioredoxin-dependent peroxide reductase from yeast. *J. Biol. Chem.* **269**: 27670–27678.
- Chae, H. Z., Kang, S. W., and Rhee, S. G., 1999, Isoforms of mammalian peroxiredoxin that reduce peroxides in presence of thioredoxin. *Methods Enzymol.* **300**: 219–226.
- Chae, H. Z., Kim, H. J., Kang, S. W., and Rhee, S. G., 1999, Characterization of three isoforms of mammalian peroxiredoxin that reduce peroxides in the presence of thioredoxin. *Diabetes Res. Clin. Pract.* **45**: 101–112.
- Chae, H. Z., Robison, K., Poole, L. B., Church, G., Storz, G., and Rhee, S. G., 1994, Cloning and sequencing of thiol-specific antioxidant from mammalian brain: alkyl hydroperoxide reductase and thiol-specific antioxidant define a large family of antioxidant enzymes. *Proc. Natl. Acad. Sci. U.S.A.* **91**: 7017–7021.
- Chang, T. S., Jeong, W., Choi, S. Y., Yu, S., Kang, S. W., and Rhee, S. G., 2002, Regulation of peroxiredoxin I activity by Cdc2-mediated phosphorylation. *J. Biol. Chem.* **277**: 25370–25376.
- Chang, T. S., Jeong, W., Woo, H. A., Lee, S. M., Park, S., and Rhee, S. G., 2004, Characterization of mammalian sulfiredoxin and its reactivation of hyperoxidized peroxiredoxin through reduction of cysteine sulfinic acid in the active site to cysteine. *J. Biol. Chem.* **279**: 50994–51001.
- Chevallet, M., Wagner, E., Luche, S., van Dorselaer, A., Leize-Wagner, E., and Rabilloud, T., 2003, Regeneration of peroxiredoxins during recovery after oxidative stress: only some overoxidized peroxiredoxins can be reduced during recovery after oxidative stress. *J. Biol. Chem.* **278**: 37146–37153.
- Christman, M. F., Morgan, R. W., Jacobson, F. S., and Ames, B. N., 1985, Positive control of a regulon for defenses against oxidative stress and some heat-shock proteins in *Salmonella typhimurium*. *Cell.* **41**: 753–762.
- Chuang, M. H., Wu, M. S., Lo, W. L., Lin, J. T., Wong, C. H., and Chiou, S. H., 2006, The antioxidant protein alkylhydroperoxide reductase of *Helicobacter pylori* switches from a peroxide reductase to a molecular chaperone function. *Proc. Natl. Acad. Sci. U.S.A.* **103**: 2552–2557.
- Claiborne, A., Yeh, J. I., Mallett, T. C., Luba, J., Crane, E. J., 3rd, Charrier, V., and Parsonage, D., 1999, Protein-sulfenic acids: diverse roles for an unlikely player in enzyme catalysis and redox regulation. *Biochemistry.* **38**: 15407–15416.
- Degols, G., Shiozaki, K., and Russell, P., 1996, Activation and regulation of the Spc1 stress-activated protein kinase in *Schizosaccharomyces pombe*. *Mol. Cell Biol.* **16**: 2870–2877.
- Dietz, K. J., Horling, F., König, J., and Baier, M., 2002, The function of the chloroplast 2-cysteine peroxiredoxin in peroxide detoxification and its regulation. *J. Exp. Bot.* **53**: 1321–1329.
- Dietz, K. J., Jacob, S., Oelze, M. L., Laxa, M., Tognetti, V., de Miranda, S. M., Baier, M., and Finkemeier, I., 2006, The function of peroxiredoxins in plant organelle redox metabolism. *J. Exp. Bot.* **57**: 1697–1709.
- Eichhorn, E., van der Ploeg, J. R., and Leisinger, T., 1999, Characterization of a two-component alkanesulfonate monooxygenase from *Escherichia coli*. *J. Biol. Chem.* **274**: 26639–26646.
- Findlay, V. J., Tapiero, H., and Townsend, D. M., 2005, Sulfiredoxin: a potential therapeutic agent? *Biomed. Pharmacother.* **59**: 374–379.
- Findlay, V. J., Townsend, D. M., Morris, T. E., Fraser, J. P., He, L., and Tew, K. D., 2006, A novel role for human sulfiredoxin in the reversal of glutathionylation. *Cancer Res.* **66**: 6800–6806.
- Finlayson, A. J., MacKenzie, S. L., and Finley, F. W., 1979, Reaction of alanine-3-sulfinic acid with 2-mercaptoethanol. *Can. J. Chem.* **57**: 2073–2077.

- Flohé, L., Budde, H., Bruns, K., Castro, H., Clos, J., Hofmann, B., Kansal-Kalavar, S., Krumme, D., Menge, U., Plank-Schumacher, K., Sztajer, H., Wissing, J., Wylegalla, C., and Hecht, H. J., 2002, Tryparedoxin peroxidase of *Leishmania donovani*: molecular cloning, heterologous expression, specificity, and catalytic mechanism. *Arch. Biochem. Biophys.* **397**: 324–335.
- Hamann, M., Zhang, T., Hendrich, S., and Thomas, J. A., 2002, Quantitation of protein sulfinic and sulfonic acid, irreversibly oxidized protein cysteine sites in cellular proteins. *Methods Enzymol.* **348**: 146–156.
- Hofmann, B., Hecht, H.-J., and Flohé, L., 2002, Peroxiredoxins. *Biol. Chem.* **383**: 347–364.
- Isermann, K., Liebau, E., Roeder, T., and Bruchhaus, I., 2004, A peroxiredoxin specifically expressed in two types of pharyngeal neurons is required for normal growth and egg production in *Caenorhabditis elegans*. *J. Mol. Biol.* **338**: 745–755.
- Jacob, C., Holme, A. L., and Fry, F. H., 2004, The sulfinic acid switch in proteins. *Org. Biomol. Chem.* **2**: 1953–1956.
- Jang, H. H., Kim, S. Y., Park, S. K., Jeon, H. S., Lee, Y. M., Jung, J. H., Lee, S. Y., Chae, H. B., Jung, Y. J., Lee, K. O., Lim, C. O., Chung, W. S., Bahk, J. D., Yun, D. J., and Cho, M. J., 2006, Phosphorylation and concomitant structural changes in human 2-Cys peroxiredoxin isotype I differentially regulate its peroxidase and molecular chaperone functions. *FEBS Lett.* **580**: 351–355.
- Jang, H. H., Lee, K. O., Chi, Y. H., Jung, B. G., Park, S. K., Park, J. H., Lee, J. R., Lee, S. S., Moon, J. C., Yun, J. W., Choi, Y. O., Kim, W. Y., Kang, J. S., Cheong, G. W., Yun, D. J., Rhee, S. G., Cho, M. J., and Lee, S. Y., 2004, Two enzymes in one; two yeast peroxiredoxins display oxidative stress-dependent switching from a peroxidase to a molecular chaperone function. *Cell.* **117**: 625–635.
- Jeong, W., Park, S. J., Chang, T. S., Lee, D. Y., and Rhee, S. G., 2006, Molecular mechanism of the reduction of cysteine sulfinic acid of peroxiredoxin to cysteine by mammalian sulfiredoxin. *J. Biol. Chem.* **281**: 14400–14407.
- Jönsson, T. J., Murray, M. S., Johnson, L. C., Poole, L. B., and Lowther, W. T., 2005, Structural basis for the retroreduction of inactivated peroxiredoxins by human sulfiredoxin. *Biochemistry.* **44**: 8634–8642.
- Kim, K., Rhee, S. G., and Stadtman, E. R., 1985, Nonenzymatic cleavage of proteins by reactive oxygen species generated by dithiothreitol and iron. *J. Biol. Chem.* **260**: 15394–15397.
- König, J., Baier, M., Horling, F., Kahmann, U., Harris, G., Schürmann, P., and Dietz, K. J., 2002, The plant-specific function of 2-Cys peroxiredoxin-mediated detoxification of peroxides in the redox-hierarchy of photosynthetic electron flux. *Proc. Natl. Acad. Sci. U.S.A.* **99**: 5738–5743.
- Koo, K. H., Lee, S., Jeong, S. Y., Kim, E. T., Kim, H. J., Kim, K., Song, K., and Chae, H. Z., 2002, Regulation of thioredoxin peroxidase activity by C-terminal truncation. *Arch. Biochem. Biophys.* **397**: 312–318.
- Kudo, N., Taoka, H., Yoshida, M., and Horinouchi, S., 1999, Identification of a novel nuclear export signal sensitive to oxidative stress in yeast AP-1-like transcription factor. *Ann. N. Y. Acad. Sci.* **886**: 204–207.
- Lee, D. Y., Rhee, S. G., Ferretti, J., and Gruschus, J. M., 2005, <sup>1</sup>H, <sup>15</sup>N, and <sup>13</sup>C chemical shift assignments of the human Sulfiredoxin (hSrx). *J. Biomol. NMR.* **32**: 339.
- Liu, X. P., Liu, X. Y., Zhang, J., Xia, Z. L., Liu, X., Qin, H. J., and Wang, D. W., 2006, Molecular and functional characterization of sulfiredoxin homologs from higher plants. *Cell Res.* **16**: 287–296.
- Martin, I. V., and MacNeill, S. A., 2002, ATP-dependent DNA ligases. *Genome Biol.* **3**: REVIEWS3005.
- Mitsumoto, A., Nakagawa, Y., Takeuchi, A., Okawa, K., Iwamatsu, A., and Takanezawa, Y., 2001, Oxidized forms of peroxiredoxins and DJ-1 on two-dimensional gels increased in response to sublethal levels of paraquat. *Free Radic. Res.* **35**: 301–310.
- Mitsumoto, A., Takanezawa, Y., Okawa, K., Iwamatsu, A., and Nakagawa, Y. (2001). Variants of peroxiredoxins expression in response to hydroperoxide stress. *Free Radic. Biol. Med.* **30**: 625–635.
- Moon, J. C., Hah, Y. S., Kim, W. Y., Jung, B. G., Jang, H. H., Lee, J. R., Kim, S. Y., Lee, Y. M., Jeon, M. G., Kim, C. W., Cho, M. J., and Lee, S. Y. (2005). Oxidative stress-dependent structural and functional switching of a human 2-Cys peroxiredoxin isotype II that enhances HeLa cell resistance to H<sub>2</sub>O<sub>2</sub>-induced cell death. *J. Biol. Chem.* **280**: 28775–28784.

- Moore, R. B., Mankad, M. V., Shriver, S. K., Mankad, V. N., and Plishker, G. A. (1991). Reconstitution of Ca(2+)-dependent K<sup>+</sup>-transport in erythrocyte membrane vesicles requires a cytoplasmic protein. *J. Biol. Chem.* **266**: 18964–18968.
- Morgan, R. W., Christman, M. F., Jacobson, F. S., Storz, G., and Ames, B. N., 1986, Hydrogen peroxide-inducible proteins in *Salmonella typhimurium* overlap with heat shock and other stress proteins. *Proc. Natl. Acad. Sci. U.S.A.* **83**: 8059–8063.
- Niimura, Y., Poole, L. B., and Massey, V., 1995, *Amphibacillus xylanus* NADH oxidase and *Salmonella typhimurium* alkyl-hydroperoxide reductase flavoprotein components show extremely high scavenging activity for both alkyl hydroperoxide and hydrogen peroxide in the presence of *S. typhimurium* alkyl-hydroperoxide reductase 22-kDa protein component. *J. Biol. Chem.* **270**: 25645–25650.
- Nogoceke, E., Gommel, D. U., Kiess, M., Kalisz, H. M., and Flohé, L., 1997, A unique cascade of oxidoreductases catalyses trypanothione-mediated peroxide metabolism in *Crithidia fasciculata*. *Biol. Chem.* **378**: 827–836.
- Pannifer, A. D., Flint, A. J., Tonks, N. K., and Barford, D., 1998, Visualization of the cysteinyl-phosphate intermediate of a protein-tyrosine phosphatase by x-ray crystallography. *J. Biol. Chem.* **273**: 10454–10462.
- Poole, L. B., 1996, Flavin-dependent alkyl hydroperoxide reductase from *Salmonella typhimurium*. 2. Cystine disulfides involved in catalysis of peroxide reduction. *Biochemistry*. **35**: 65–75.
- Quinn, J., Findlay, V. J., Dawson, K., Millar, J. B., Jones, N., Morgan, B. A., and Toone, W. M., 2002, Distinct regulatory proteins control the graded transcriptional response to increasing H<sub>2</sub>O<sub>2</sub> levels in fission yeast *Schizosaccharomyces pombe*. *Mol. Biol. Cell.* **13**: 805–816.
- Rhee, S. G., 2006, Cell signaling. H<sub>2</sub>O<sub>2</sub>, a necessary evil for cell signaling. *Science*. **312**: 1882–1883.
- Schröder, E., Littlechild, J. A., Lebedev, A. A., Errington, N., Vagin, A. A., and Isupov, M. N., 2000, Crystal structure of decameric 2-Cys peroxiredoxin from human erythrocytes at 1.7 Å resolution. *Structure Fold Des.* **8**: 605–615.
- Seaver, L. C., and Imlay, J. A., 2001, Hydrogen peroxide fluxes and compartmentalization inside growing *Escherichia coli*. *J. Bacteriol.* **183**: 7182–7189.
- Shiozaki, K., and Russell, P., 1995, Cell-cycle control linked to extracellular environment by MAP kinase pathway in fission yeast. *Nature*. **378**: 739–743.
- Shiozaki, K., and Russell, P., 1996, Conjugation, meiosis, and the osmotic stress response are regulated by Spc1 kinase through Atf1 transcription factor in fission yeast. *Genes Dev.* **10**: 2276–2288.
- Timson, D. J., Singleton, M. R., and Wigley, D. B., 2000, DNA ligases in the repair and replication of DNA. *Mutat. Res.* **460**: 301–318.
- Toone, W. M., Kuge, S., Samuels, M., Morgan, B. A., Toda, T., and Jones, N., 1998, Regulation of the fission yeast transcription factor Pap1 by oxidative stress: requirement for the nuclear export factor Crm1 (Exportin) and the stress-activated MAP kinase Sty1/Spc1. *Genes Dev.* **12**: 1453–1463.
- Traut, T. W., 1994, The functions and consensus motifs of nine types of peptide segments that form different types of nucleotide-binding sites. *Eur. J. Biochem.* **222**: 9–19.
- Veal, E. A., Findlay, V. J., Day, A. M., Bozonet, S. M., Evans, J. M., Quinn, J., and Morgan, B. A., 2004, A 2-Cys peroxiredoxin regulates peroxide-induced oxidation and activation of a stress-activated MAP kinase. *Mol. Cell.* **15**: 129–139.
- Velasco-Miguel, S., Buckbinder, L., Jean, P., Gelbert, L., Talbott, R., Laidlaw, J., Seizinger, B., and Kley, N., 1999, PA26, a novel target of the p53 tumor suppressor and member of the GADD family of DNA damage and growth arrest inducible genes. *Oncogene*. **18**: 127–137.
- Vivancos, A. P., Castillo, E. A., Biteau, B., Nicot, C., Ayte, J., Toledano, M. B., and Hidalgo, E., 2005, A cysteine-sulfinic acid in peroxiredoxin regulates H<sub>2</sub>O<sub>2</sub>-sensing by the antioxidant Pap1 pathway. *Proc. Natl. Acad. Sci. U.S.A.* **102**: 8875–8880.
- Vivancos, A. P., Castillo, E. A., Jones, N., Ayte, J., and Hidalgo, E., 2004, Activation of the redox sensor Pap1 by hydrogen peroxide requires modulation of the intracellular oxidant concentration. *Mol. Microbiol.* **52**: 1427–1435.
- Wilkinson, M. G., Samuels, M., Takeda, T., Toone, W. M., Shieh, J. C., Toda, T., Millar, J. B., and Jones, N., 1996, The Atf1 transcription factor is a target for the Sty1 stress-activated MAP kinase pathway in fission yeast. *Genes Dev.* **10**: 2289–2301.



- Woo, H. A., Chae, H. Z., Hwang, S. C., Yang, K. S., Kang, S. W., Kim, K., and Rhee, S. G., 2003, Reversing the inactivation of peroxiredoxins caused by cysteine sulfinic acid formation. *Science*. **300**: 653–656.
- Woo, H. A., Jeong, W., Chang, T. S., Park, K. J., Park, S. J., Yang, J. S., and Rhee, S. G., 2005, Reduction of cysteine sulfinic acid by sulfiredoxin is specific to 2-Cys peroxiredoxins. *J. Biol. Chem.* **280**: 3125–3128.
- Woo, H. A., Kang, S. W., Kim, H. K., Yang, K. S., Chae, H. Z., and Rhee, S. G., 2003, Reversible oxidation of the active site cysteine of peroxiredoxins to cysteine sulfinic acid. Immunoblot detection with antibodies specific for the hyperoxidized cysteine-containing sequence. *J. Biol. Chem.* **278**: 47361–47364.
- Wood, Z. A., Poole, L. B., and Karplus, P. A., 2003, Peroxiredoxin evolution and the regulation of hydrogen peroxide signaling. *Science*. **300**: 650–653.
- Wood, Z. A., Schröder, E., Harris, R. J., and Poole, L. B., 2003, Structure, mechanism and regulation of peroxiredoxins. *Trends Biochem. Sci.* **28**: 32–40.
- Yang, K. S., Kang, S. W., Woo, H. A., Hwang, S. C., Chae, H. Z., Kim, K., and Rhee, S. G., 2002, Inactivation of human peroxiredoxin I during catalysis as the result of the oxidation of the catalytic site cysteine to cysteine-sulfinic acid. *J. Biol. Chem.* **277**: 38029–38036.

## CHAPTER 7

# PEROXIREDOXINS IN BACTERIAL ANTIOXIDANT DEFENSE

JAMES M. DUBBS<sup>1</sup> AND SKORN MONGKOLSUK<sup>1,2</sup>

<sup>1</sup>Laboratory of Biotechnology, Chulabhorn Research Institute, Lak Si, Bangkok 10210, and

<sup>2</sup>Department of Biotechnology, Faculty of Science, Mahidol University, Bangkok 10400, Thailand

**Abstract:** Peroxiredoxins constitute an important component of the bacterial defense against toxic peroxides. These enzymes use reactive cysteine thiols to reduce peroxides with electrons ultimately derived from reduced pyridine dinucleotides. Studies examining the regulation and physiological roles of AhpC, Tpx, Ohr and OsmC reveal the multi-layered nature of bacterial peroxide defense. AhpC is localized in the cytoplasm and has a wide substrate range that includes H<sub>2</sub>O<sub>2</sub>, organic peroxides and peroxyntirite. This enzyme functions in both the control of endogenous peroxides, as well as in the inducible defense response to exogenous peroxides or general stresses. Ohr, OsmC and Tpx are organic peroxide specific. Tpx is localized to the periplasm and can be involved in either constitutive peroxide defense or participate in oxidative stress inducible responses depending on the organism. Ohr is an organic peroxide specific defense system that is under the control of the organic peroxide sensing repressor OhrR. In some organisms Ohr homologs are regulated in response to general stress. Clear evidence indicates that AhpC, Tpx and Ohr are involved in virulence. The role of OsmC is less clear. Regulation of OsmC expression is not oxidative stress inducible, but is controlled by multiple general stress responsive regulators

**Keywords:** Peroxiredoxin, Oxidative stress, Gene regulation, Ohr, OsmC, AhpC, Tpx, OhrR, OxyR, PerR, HypR, Organic peroxide, Hydrogen peroxide, Peroxynitrite, Bacteria, Virulence

## 1. INTRODUCTION

Life in the presence of oxygen is advantageous for many organisms, but there are a few disastrous consequences of this life style that all life forms have to deal with to survive. Molecular oxygen is stable, but toxic reactive oxygen species (ROS) can be generated by its reduction (Reviewed in: Halliwell and Gutteridge, 1984). A one-electron reduction of molecular oxygen generates superoxide anion (O<sub>2</sub><sup>•-</sup>), while a two-electron reduction leads to the production of H<sub>2</sub>O<sub>2</sub>. Superoxide anion is a moderately reactive compound capable of oxidizing thiols, and proteins containing

iron-sulphur clusters, thus releasing free iron. A further one electron reduction of superoxide, e.g. by superoxide itself, converts it to  $\text{H}_2\text{O}_2$  and molecular oxygen. The reaction occurs spontaneously or can be catalyzed by superoxide dismutases.  $\text{H}_2\text{O}_2$  is a nonradical and has relatively low reactivity; however, it is a precursor of highly reactive hydroxyl radicals ( $\bullet\text{OH}$ ) for which cells have no enzymatic defense systems. Hydroxyl radicals are generated via the iron-catalyzed Harber-Weiss reaction of  $\text{H}_2\text{O}_2$  with superoxide anions, or with ferrous or cuprous cations from  $\text{H}_2\text{O}_2$  in the Fenton reaction, as listed below:

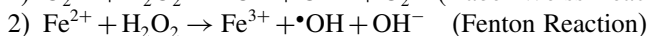
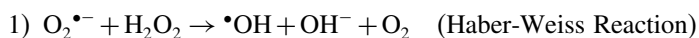

Hydroxyl radicals have a high redox potential (+2.38V) and are highly reactive. Thus, hydroxyl radical toxicity occurs at the site of its generation since it oxidizes most biological macromolecules at a diffusion-limited rate. Singlet oxygen may be generated *in vivo* by the action of enzymes on superoxide, peroxyglutathione and light-dependent reactions in the presence of endogenous or exogenous sensitizers. Metals can also catalyze the production of singlet oxygen. Most reactions of singlet oxygen involve its addition to conjugated double bonds of macromolecules. These ROS can react with macromolecules and generate other reactive oxygenated compounds and radicals, such as organic peroxides (ROOH), lipid hydroperoxides and peroxy radicals. All of the ROS mentioned above have the ability to oxidize cellular macromolecules, including DNA and lipids.

Bacteria come into contact with ROS that are derived from both internal and external sources (Reviewed in: Pomposiello and Demple, 2002; Imlay, 2003). Aerobic metabolism is an important source of internal ROS production. Oxygen can accept electrons from components of the cellular electron transport chain resulting in the production of superoxide, which is readily converted to  $\text{H}_2\text{O}_2$ . A similar reaction can also take place during photosynthetic electron transport where electrons can be transferred to  $\text{O}_2$  instead of  $\text{NADP}^+$ . Light harvesting antennae pigments of photosynthetic organisms, can also transfer excited electrons to oxygen resulting in singlet oxygen production. Other biochemical pathways can also give rise to harmful oxidants. For example, the process of denitrification leads to the unwanted formation of nitric oxide ( $\text{NO}^\bullet$ ), a toxic reactive compound that, in the presence of superoxide, spontaneously converts to peroxynitrite ( $\text{ONOO}^\bullet$ ). (see also Chapter 5).

External sources of ROS include exposure to host cell defense mechanisms during the infection process. Animal cells, such as macrophages and neutrophils, produce enzymes that generate large amounts of superoxide,  $\text{H}_2\text{O}_2$ ,  $\text{NO}^\bullet$  and, in consequence, peroxynitrite in response to microbial invasion. Plant cells have also been shown to actively produce these reactive compounds, as well as lipid peroxides, in response to microbial attack. Other microorganisms, including some bacteria, actively produce  $\text{H}_2\text{O}_2$  to kill off or inhibit the growth of competitors. Redox cycling compounds are another external source of ROS. These compounds can take part in a cyclic reaction involving their oxidation by molecular oxygen to form  $\text{O}_2^{\bullet-}$  followed by their enzymatic re-reduction. In the presence of  $\text{O}_2$ , this process

can generate large quantities of superoxide. Redox cycling compounds are prevalent in natural environments and can arise from man made sources, such as pesticides (i.e. paraquat) and other industrial chemicals, or can occur naturally (i.e. quinones). UV light can produce singlet oxygen and  $H_2O_2$  in reactions involving chromophores, while ionizing radiation gives rise to radicals through the radiolysis of water. Since the sources of ROS production are highly diverse, bacteria encounter these harmful oxidants irrespective of their natural habitat. Therefore pathways have evolved to eliminate ROS before they have the opportunity to react with, and damage, cellular constituents. These pathways include both enzymatic and non-enzymatic detoxification mechanisms.

The initial line of defense for most bacteria is the presence of small antioxidant molecules such as, ascorbate and  $\alpha$ -tocopherol. These molecules constitute a constitutive baseline defense, as the expression of genes encoding enzymes responsible for their synthesis are not oxidative stress-inducible. Another important small antioxidant molecule, glutathione (L-glutamyl-L-cysteinylglycine or GSH), is present in high concentrations in most bacteria. GSH can act directly as an ROS scavenger or, more importantly, as a co-factor of enzymes involved in oxidative stress protection. GSH also participates in the repair of oxidatively damaged macromolecules. In bacteria that do not produce GSH, related peptide thiols, along with their corresponding reductases, are normally found that perform analogous functions. Bacteria also produce thioredoxins and glutaredoxins. These are small, ubiquitous, evolutionarily conserved proteins that can also function as direct ROS scavengers. However, their primary role is as thiol-disulphide oxidoreductases involved in the reduction of protein disulphide bonds: a process that is necessary for the function of some oxidative stress protective enzymes (i.e. methionine sulfoxide reductase or peroxiredoxins) and the regeneration of peptide thiols. The re-reduction of thioredoxin, glutaredoxin and the peptide thiols is ultimately dependent on electrons supplied by NADPH and NADH. Consequently, the ratio of reduced NADPH and NADH to oxidized  $NADP^+$  and  $NAD^+$  affects the cells ability to control ROS levels. Reduction of these compounds is dependent on various metabolic pathways, most notably glycolysis and the pentose phosphate pathway. Therefore, any general stress that reduces the levels of NADPH and NADH may also affect the cellular levels of ROS.

ROS detoxification enzymes constitute a major component of bacterial oxidative stress defense systems. Basal levels of ROS protective enzymes work in concert to remove endogenously produced ROS and maintain their levels within physiologically safe limits. The primary superoxide removal enzymes are the superoxide dismutases (Sods). These enzymes catalyze dismutation of superoxide to form  $H_2O_2$  and  $O_2$  and can vary in regard to the metal co-factor utilized at their active sites. One major class of enzymes involved in  $H_2O_2$  removal is the catalases. Most bacteria have two types of catalase namely the monofunctional catalases and the bifunctional catalase/oxidases. Both have been shown to be important in maintaining bacterial resistance levels to  $H_2O_2$ . Regulatory networks that are redox sensitive or

respond to general stresses that stimulate ROS production often control expression of these protective enzymes.

A large class of enzymes that has increasingly been recognized as an important player in the bacterial defense against organic and inorganic peroxides is the peroxiredoxins. This diverse class of peroxide reductases shares a common mechanism that utilizes reactive thiols to reduce peroxides to their corresponding alcohols and water with reducing equivalents that are ultimately supplied by NADH and/or NADPH. This chapter examines the regulation and physiological function of AhpC, Tpx, Ohr and OsmC, four of the best-studied bacterial peroxiredoxins. These peroxiredoxins typify the layered nature of bacterial oxidative stress defenses. The particular substrate preference, regulatory behavior and physiological role of each enzyme can vary depending on the organism. Aspects of the physiological function and gene regulation of these enzymes are likely to be applicable to other peroxiredoxin systems.

## 2. BACTERIAL ALKYLHYDROPEROXIDASE: AhpC

AhpC (Alkylhydroperoxidase) is the most extensively studied bacterial peroxiredoxin system. The enzyme was first isolated and characterized from extracts of regulatory mutants of *Salmonella typhimurium* and *Escherichia coli* that over expressed AhpC, as well as a number of other oxidative stress-related proteins, and displayed increased resistance to H<sub>2</sub>O<sub>2</sub> and organic peroxides (Christman *et al.*, 1985; Greenberg and Demple, 1988; Jacobson *et al.*, 1989; Storz *et al.*, 1989). AhpC is known to be a cytoplasmic protein in *E. coli* (Cha *et al.*, 2004) and AhpC-homologous peroxiredoxin systems have been identified in a wide variety of prokaryotes representing both eubacteria and archaea (Chae *et al.*, 1994; Poole *et al.*, 2000a). While the substrate preference of AhpC can vary from organism to organism, the enzyme has the ability to reduce a broad range of peroxides due to the presence of a large hydrophobic active site pocket (Wood *et al.*, 2002; Wood *et al.*, 2003). Substrates range from H<sub>2</sub>O<sub>2</sub> and simple organic peroxides like *tert*-butyl hydroperoxide, to more complex organic peroxides such as; cumene hydroperoxide, lipoic acid hydroperoxide, thymidine hydroperoxide and peroxyntirite (Cha *et al.*, 1995; Bryk *et al.*, 2000; Hillas *et al.*, 2000).

As members of the two-cysteine peroxiredoxin family, all AhpCs contain conserved peroxidatic and resolving cysteine residues, essential for catalytic function, that correspond to positions C46 (peroxidatic cysteine) and C165 (resolving cysteine) in the *E. coli* and *Salmonella* proteins (Ellis and Poole, 1997; Wood *et al.*, 2002). Briefly, the peroxidatic cysteine reacts with peroxide (ROOH) to yield the corresponding alcohol (ROH), or water in the case of H<sub>2</sub>O<sub>2</sub>, and cysteine sulfenic acid (Cys-SOH). This peroxidatic cysteine sulfenic acid is then reduced by the free thiol of the resolving cysteine residue to form a disulfide bond between the two residues and release a water molecule. The participation of an AhpC reductase system is then required for the reduction of the disulfide bond to complete the catalytic cycle. *In vivo*, AhpC reduction is usually accomplished using

electrons supplied by NADH or NADPH that are transferred to the enzyme through disulfide reducing systems composed of one or more proteins that can vary between organisms (Poole *et al.*, 2000b; see Chapter 4).

The basic enzymatically active unit of AhpC is a homodimer of identical subunits associated in a head to tail configuration, such that the peroxidatic cysteine of one subunit is positioned opposite the resolving cysteine of the other subunit, resulting in two catalytic sites per dimer. The crystal structures of several bacterial AhpCs have been solved and in most cases the protein crystallizes as a dimer ( $\alpha_2$ ) or a decamer composed of 5 homodimers ( $\alpha_2$ )<sub>5</sub> organized into a toroidal (doughnut-shaped) structure (Wood *et al.*, 2003). In solution, AhpC exists as a mixture of dimers and decamers and the extent of decamer formation is influenced by the oxidation/reduction state of the protein. Reduction or over-oxidation favors decamer formation while a moderate level of oxidation induces conformational changes favoring dissociation to dimers. Decamer formation has been shown to increase AhpC activity relative to that of dimers and it has been suggested that post-translational factors affecting the dimer/decamer transition are a potential means of regulating enzymatic activity *in vivo*; however, the physiological significance of this phenomenon in bacteria has yet to be determined (Wood *et al.*, 2002; Parsonage *et al.*, 2005; see also Chapter 3).

As stated earlier, completion of the catalytic cycle of AhpC requires a disulfide reductase system to reduce the intermolecular disulfide bond formed between the peroxidatic and resolving cysteines. To accomplish this, bacteria employ disulphide reductase systems that generally derive their reducing equivalents from either NADH or NADPH. They can be either specific to AhpC or function as a more general cellular reducing system such as the thioredoxin/thioredoxin reductase system. AhpCs that use a general reducing system include those of *Helicobacter pylori* (Baker *et al.*, 2001) and *Mycobacterium tuberculosis* (Jaeger *et al.*, 2004) that use the thioredoxin/thioredoxin reductase system (see Chapter 9). Bacterial thioredoxin reductase is a dimeric enzyme that contains one flavin and one redox active disulphide per subunit (Williams *et al.*, 2000). Using reducing equivalents supplied by NADPH, this enzyme reduces thioredoxin that in turn reduces the intermolecular disulphide bond in oxidized AhpC. While referred to here as a general reducing system, specificity can be introduced through the peroxiredoxin's preference for a particular thioredoxin homolog. An example of this is seen in the case of *M.tuberculosis* AhpC (Jaeger *et al.*, 2004) where AhpC is efficiently reduced by only one (TrxC) of the three thioredoxins produced by the organism. *Helicobacter pylori* AhpC also displays specificity for only one (Trx1) of the organism's two thioredoxins (Baker *et al.*, 2001).

Two AhpC specific peroxiredoxin reductases have been reasonably well characterized. AhpF is an AhpC specific peroxiredoxin reductase that is widely distributed (Poole *et al.*, 2000a). The C-terminus of AhpF is structurally and functionally homologous to bacterial thioredoxin reductases and contains FAD and pyridine nucleotide binding sites along with a redox active CXXC motif. The non-homologous N-terminus contains an additional CXXC motif. Electrons from NADH

are transferred, via FAD and the C-terminal redox active disulphide, to the N-terminal disulphide of AhpF and finally to oxidized AhpC (Poole *et al.*, 2000b).

A second AhpC specific reductase, AhpD, found in *Mycobacteria* and *Corynebacterium diphtheriae* (Tai and Zhu, 1995; Hillas *et al.*, 2000), is part of a three-protein peroxiredoxin reductase system that transfers electrons derived from NADPH to oxidized AhpC. Dihydrolipoamide dehydrogenase (LpdC) mediates the NADPH-dependent reduction of dihydrolipoamide acetyl transferase (DlaT). DlaT then reduces a redox active CXXC motif in AhpD that can then donate electrons to oxidized AhpC (Bryk *et al.*, 2002; Shi and Ehart, 2006).

## 2.1. OxyR Mediated Regulation of AhpC

OxyR was the first peroxide-sensing transcriptional regulatory protein to be well characterized (Storz and Zheng, 2000; Zheng and Storz, 2000). OxyR is a member of the LysR family of transcriptional regulators (Henikoff *et al.*, 1988; Schell, 1993). Members of this family are usually positive regulators that, in response to a metabolic signal (i.e. usually the binding of a metabolite or co-inducer molecule), activate transcription of target genes. LysR-type regulators often control genes encoding components of metabolic pathways and respond to a co-inducer that is a substrate or intermediate of the pathway they regulate. OxyR differs from this paradigm somewhat in that, instead of binding a co-inducer, it senses the redox state of the cell through the direct oxidation of a reactive cysteine residue (C199).

Figure 1 outlines a general scheme for OxyR-mediated gene regulation in response to oxidative stress. Oxidation of this residue induces a conformational change in the protein that alters its DNA binding properties and facilitates RNA polymerase access to the promoter. In the active oxidized form, an *E. coli* OxyR tetramer binds to one face of the helix, at four consecutive major grooves, to a sequence consisting of four ATAGnt motifs that are separated by 10bps. In the reduced inactive form, the binding site condenses to span two major grooves (Toledano *et al.*, 1994). Activation of transcription occurs through direct interaction of OxyR with RNA polymerase (Storz *et al.*, 1990; Kullik *et al.*, 1995). Feedback control of the system is achieved through the enzymatic reduction of OxyR by glutaredoxin 1 (GrxA) and glutathione ensuring deactivation of OxyR as peroxide levels are reduced (Zheng *et al.*, 1998).

How OxyR is exactly activated is a subject of some controversy. Two hypotheses have been proposed and the evidence for and against each one has been summarized in several reviews (Helmann, 2002; Paget and Buttner, 2003). The first hypothesis contends that oxidation of Cys-199 of OxyR by peroxide results in the formation of a Cys-sulfenic acid intermediate (Cys-SOH). This then reacts with Cys-208 to form an intra-molecular disulfide bond resulting in conformational changes that activate OxyR. Disulfide bond formation has been detected in wild-type OxyR purified under aerobic conditions (Lee *et al.*, 2004).

The second hypothesis posits that modification of Cys-199 alone is responsible for the activation and that multiple types of modifications are possible

## Mechanism of OxyR mediated regulation

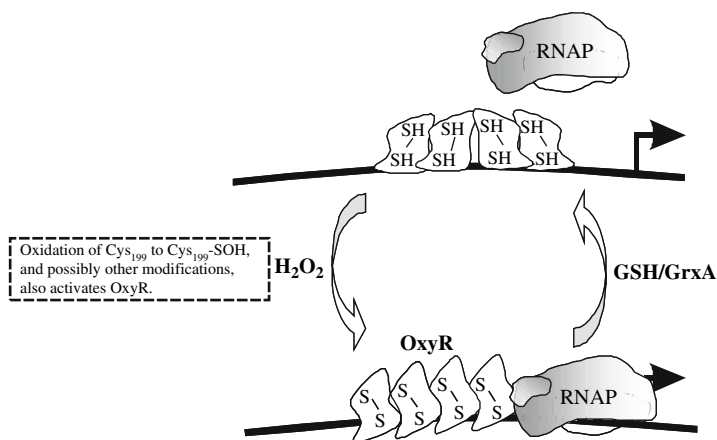

*Figure 1.* Model of OxyR mediated gene regulation in *E. coli*. Oxidation of Cys199 leads to the formation of an intramolecular disulfide bond with Cys208. Conformational changes in OxyR in response to oxidation allow recruitment of RNA polymerase and the initiation of transcription. Activation can also occur upon oxidation of Cys199 alone. Other modifications to Cys199 may also stimulate activation. In the absence of oxidants OxyR is actively re-reduced. Solid bent arrows indicate transcription starts

such as: Cys-SOH formation, nitrosylation (Cys-SNO), and glutathionylation (Cys-S-S-G) (Hausladen *et al.*, 1996). Furthermore, the different types of modifications to OxyR are proposed to elicit different levels of activation (Kim *et al.*, 2002). The issue has yet to be resolved. The weight of evidence so far seems to favor disulphide bond formation, although Kim *et al.* (2002) have shown that oxidation of Cys-199 alone can activate OxyR.

In *E. coli* and *Salmonella typhimurium* OxyR is known to regulate at least 30 genes in response to H<sub>2</sub>O<sub>2</sub> exposure. Some of these are involved in oxidative stress defense and recovery and include; *katG*, encoding catalase, *dps*, encoding a DNA binding protein that sequesters iron, and *ahpC* (Christman *et al.*, 1985; Morgan *et al.*, 1986; Francis *et al.*, 1997; Zheng *et al.*, 2001b). In both organisms *ahpC* is closely linked to a downstream *ahpF* (Storz *et al.*, 1989; Tartaglia *et al.*, 1990) (Fig. 2A). OxyR regulates *ahpC* expression through direct binding to sites that are immediately upstream of a  $\sigma^{70}$ -consensus promoter, sometimes overlapping the -35-consensus sequence.

The *S. typhimurium ahpCF* operons possess a single promoter that directs transcription initiation at a site 24 bp upstream of the *ahpC* translation start (Tartaglia *et al.*, 1989). Expression of *ahpC* and *ahpF* in *S. typhimurium* is induced in response to H<sub>2</sub>O<sub>2</sub> and the organic peroxide cumene hydroperoxide in an OxyR dependent manner (Morgan *et al.*, 1986; Storz *et al.*, 1989). *AhpF* expression alone is also induced in response to heat shock. This requires OxyR, but does not require the heat shock specific sigma factor,  $\sigma^H$  (Morgan *et al.*, 1986), suggesting the existence of



A. OxyR Regulated

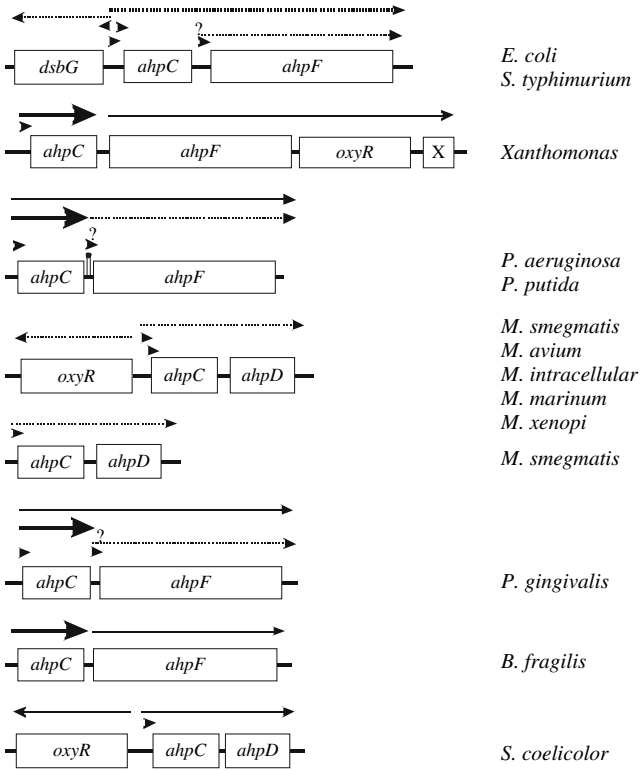

B. PerR regulated

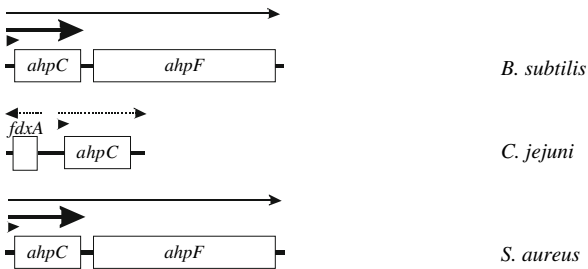

C. HypR Regulated

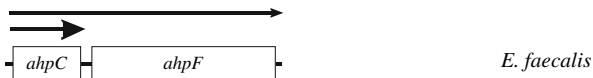

D. Indeterminant Regulation

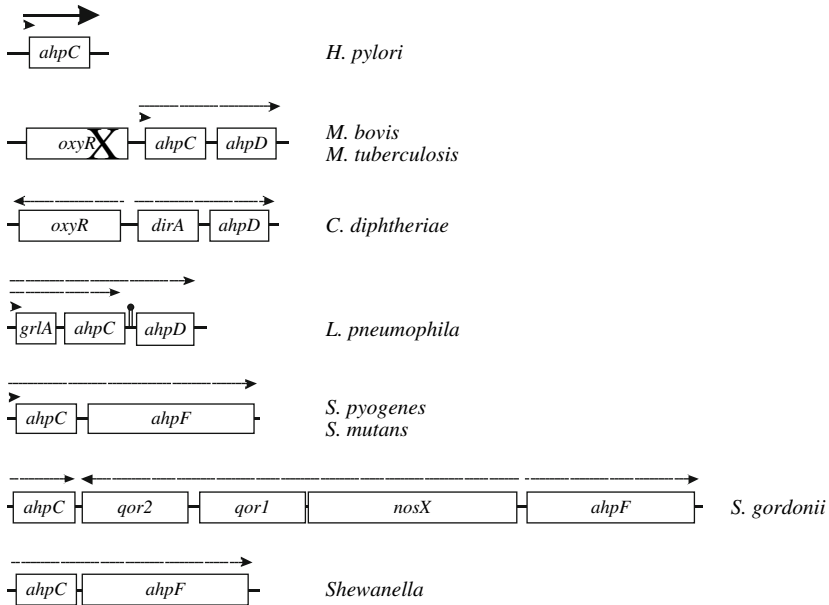

Figure 2. Transcriptional organization of several bacterial *ahpC* operons. The transcriptional organization of *ahpC* operons described in the text are shown. Solid arrows indicate transcripts. The thickness of the arrows reflects the relative abundance of the mRNAs. Dashed arrows indicate potential transcripts inferred from the gene organization, as well as any additional information such as the presence of promoters or the positions of mRNA end points. Arrowheads indicate the positions of transcription starts and functional promoters. Lollipops denote hairpin loops that may function as transcription terminators

either a heat induced OxyR-dependent post-transcriptional regulatory mechanism or a second promoter, possibly within *ahpC*, that is OxyR dependent. *S. typhimurium ahpC* and *ahpF* expression is also induced upon intracellular growth in mouse macrophages suggesting a role in virulence (Francis and Gallagher, 1993).

Like *S. typhimurium*, the *E. coli ahpCF* operon possesses an OxyR-dependent  $\sigma^{70}$ -promoter (P1) that initiates transcription 24 bp upstream of *ahpC*. A second, weaker, OxyR-regulated promoter (P2) is also present that initiates transcription 228 bps upstream of *ahpC*. OxyR binds upstream of each of these promoters (Zheng *et al.*, 2001a). To complicate matters, a divergently transcribed gene encoding DsbG, a periplasmic disulfide isomerase and protein chaperone (Shao *et al.*, 2000), is present 371 bps upstream of *ahpC*. The transcription start of *dsbG* is positioned between AhpC P1 and P2 and binding of OxyR to the intergenic region activates both *ahpC* P1, P2 and *dsbG* P transcription suggesting that regulation of these overlapping promoters may be more complex than originally thought (Zheng *et al.*, 2001a). A similar positioning of OxyR binding sites between *ahpC* and *dsbG* in

*Salmonella* suggests that promoter organization of *ahpC* and *dsbG* is the same in both organisms (Tartaglia *et al.*, 1989).

Transcription profiles of *E. coli* grown in the presence of H<sub>2</sub>O<sub>2</sub> indicate that *ahpC* and *ahpF* are induced by approximately 20-fold and that induction is OxyR-dependent (Zheng *et al.*, 2001a; Zheng *et al.*, 2001b). Additional expression studies show that induction also occurs in response to exposure to organic solvents (Lambert *et al.*, 1997; Garbe *et al.*, 2000), heat and high osmolarity (Wang and Doyle, 1998; Michan *et al.*, 1999), acid pH during aerobic growth (Blankenhorn *et al.*, 1999), and upon entry into stationary phase (Michan *et al.*, 1999). Induction of *ahpCF* operon expression by high salt is *oxyR*-independent but requires *rpoS*, encoding a stress-specific sigma factor ( $\sigma^S$ ) (Michan *et al.*, 1999).

While the mechanism involved in *rpoS*-mediated regulation of *E. coli ahpCF* operon expression is not known, *ahpC* expression in *E. coli* is controlled by at least two regulatory systems and there is some evidence that other regulators may be involved in the control of *ahpC* expression as well. Genome wide scans for the presence of regulatory sequences detected a potential binding site for MetJ, an S-adenosyl-methionine-dependent repressor of genes encoding enzymes involved in methionine biosynthesis (Old *et al.*, 1991) overlapping the *ahpC* start codon (Liu *et al.*, 2001). Sequence analyses also detected a potential SigmaE ( $\sigma^E$ ) consensus promoter within *ahpC* that would be predicted to drive the expression of *ahpF*.  $\sigma^E$  is activated in response to stresses that result in mis-folded membrane proteins such as: ethanol exposure and heat (Ades, 2004). Finally, *E. coli ahpCF* operon transcription is also induced in response to phagocytosis by human neutrophils suggesting that it may also act as a virulence factor (Staudinger *et al.*, 2002).

Evidence supporting OxyR-dependent regulation of *ahpC* has also been found in: *Xanthomonas* (Mongkolsuk *et al.*, 1998b; Loprasert *et al.*, 2000), *Pseudomonas* (Fukumori and Kishii, 2001) (Ochsner *et al.*, 2000), *Mycobacteria* (Pagan-Ramos *et al.*, 1998; Pagan-Ramos *et al.*, 2006), *Porphyromonas* (Ohara *et al.*, 2006), *Bacteroides* (Rocha *et al.*, 2000) and *Streptomyces* (Hahn *et al.*, 2002).

The *ahpC* operon in *Xanthomonas campestris* is a notable exception to the typical *ahpC-ahpF* gene organization (Loprasert *et al.*, 1997; Mongkolsuk *et al.*, 1997). In this plant-pathogenic soil bacterium the *ahpC* operon consists of *ahpC-ahpF-oxyR-orfX*, where *orfX* encodes a putative protein of unknown function (Fig. 2A). Transcript analyses indicate that *ahpC* is encoded on a monocistronic mRNA of 600 nucleotides initiating from a promoter upstream of *ahpC*, while *ahpF-oxyR* and *orfX* are co-transcribed on a 3 kb transcript (Loprasert *et al.*, 2000). Primer extension analysis identified two menadione-inducible transcription start points for the *ahpC* message at 15 bp (P2) and 40 bp (P1) upstream of the *ahpC* transcription start. While P2 was the stronger signal of the two, P1 was flanked upstream by a *Xanthomonas*  $\sigma^{70}$ -consensus promoter sequence and the DNaseI footprint of OxyR was found to occur upstream of this region partially overlapping the  $-35$  sequence. Furthermore, insertion of an antibiotic resistance cassette within the OxyR binding site, but upstream of the consensus  $-35$  region, results in the production of a normal sized *ahpC* message that is no longer regulated in response to oxidative

stress. P2 was therefore designated as the true *ahpC* transcription start and it was assumed that P1 resulted from premature termination of reverse transcriptase at a long stretch of G and C residues upstream of P1 (Loprasert *et al.*, 2000). It is not known if the 3 kb *ahpF-oxr-orfX* transcript is the result of processing of a larger *ahpC-ahpF-oxr-orfX* message or if it initiates from a second promoter downstream of *ahpC* possibly within the 213 bp *ahpC-ahpF* intergenic region. A *Xanthomonas oxyR* mutant no longer induces *ahpC* in response to oxidants but basal expression of *ahpC* is significantly increased compared to wild type. Thus, unlike other OxyR-regulated *ahpC* operons, *Xanthomonas* OxyR acts as both a positive regulator of *ahpC* expression during oxidative stress and a repressor in its absence (Mongkolsuk *et al.*, 1998b; Loprasert *et al.*, 2000).

Western analyses indicate that AhpC synthesis is increased 4- to 5-fold in the presence of peroxides (H<sub>2</sub>O<sub>2</sub>, *tert*-butyl hydroperoxide, cumene hydroperoxide), inducers of superoxide production (menadione and paraquat) and CdCl<sub>2</sub>. Northern blot analyses confirm that regulation occurs at the transcriptional level. Additional Western analyses show that *Xanthomonas* AhpC synthesis is also induced by: N-ethylmaleimide (a thiol modifying agent) and alkaline pH, while thermal and osmotic stress have no effect (Mongkolsuk *et al.*, 1997; Banjerdikij *et al.*, 2005).

RNase protection studies in *Pseudomonas aeruginosa* indicate that the *ahpC-ahpF* operon gives rise to a monocistronic mRNA encoding *ahpC* and a dicistronic message encoding *ahpC* and *ahpF* that initiate 60 nucleotides upstream of the *ahpC* translation start (Fig. 2A). A third monocistronic mRNA encoding *ahpF*, that may result from either a second promoter or an mRNA processing site within the *ahpC-ahpF* intergenic region, has been detected but has not been characterized. OxyR binds to the *ahpC* promoter immediately upstream of the -35 promoter element in a region containing sequences similar to the *E. coli* consensus OxyR binding motif. Inactivation of OxyR results in the complete absence of *ahpC* promoter activity, as was measured using an *ahpC*-promoter *lacZ* fusion construct in the presence or absence of the oxidative stress inducer paraquat. *ahpC* promoter *lacZ* fusion studies also show that the *Pseudomonas ahpCF* operon is induced by H<sub>2</sub>O<sub>2</sub> and cumene hydroperoxide (Ochsner *et al.*, 2000).

The *ahpC-ahpF* operon of the toluene resistant *Pseudomonas putida* strain KT2442TOL gives rise to a predominant 700 bp transcript encoding *ahpC* and a less abundant 2700 nucleotide transcript, encoding *ahpC* and *ahpF*, originating from a point 37 nucleotides upstream of the *ahpC* translation start (Fukumori and Kishii, 2001) (Fig. 2A). The region upstream of this site contains a sequence similar to the *E. coli* OxyR binding motif. The *ahpC* and *ahpC-ahpF* messages may result from partial read through of a terminator or processing at a stretch of sequence within the *ahpC-ahpF* intergenic region that contains several potential hairpin loops. This is suggested by the fact that deletion of this region in a plasmid-borne copy of the *Pseudomonas ahpCF* operon results in an increase in the 2700 bp *ahpCF* mRNA in *E. coli*. An additional mRNA, of approximately 1400 nucleotides, encoding *ahpF*, has also been detected that may be the result of processing or a second promoter. The differential accumulation of the *ahpC* and *ahpCF* transcripts mirrors the relative

levels of AhpC and AhpF in crude extracts (Fukumori and Kishii, 2001). Proteomic studies of the parent strain, *Pseudomonas putida* KT2442 indicate that AhpC is induced upon exposure to the organic solvents; phenol and methyl *tert*-butyl ether (MTBE) (Krayl *et al.*, 2003).

OxyR controls *ahpC* expression in several members of the *Mycobacteria*. In *M. leprae*, *M. avium*, *M. intracellulare*, *M. marinum* and *M. xenopi*, *ahpC* is divergently transcribed from a closely linked *oxyR*, while *ahpC* and *oxyR* in *M. smegmatis* are not linked (Pagan-Ramos *et al.*, 1998; Pagan-Ramos *et al.*, 2006) (Fig. 2A). With the exception of *M. smegmatis*, where *oxyR* binding to the *ahpC* promoter region has not been demonstrated, the *oxyR-ahpC* intergenic region from each of these organisms binds *oxyR* at a sequence similar to the mycobacterial consensus OxyR binding sequence ATC-N<sub>9</sub>-GAT (Dhandayuthapani *et al.*, 1996; Dhandayuthapani *et al.*, 1997; Pagan-Ramos *et al.*, 1998).

Transcription of *M. leprae ahpC* initiates at -46 (P1) and -87 bp (P2) upstream of the *ahpC* translation start with an OxyR binding site positioned immediately upstream of P2. Transcription of divergently transcribed *oxyR* initiates from two points within the *oxyR-ahpC* intergenic region; one start point is within the OxyR binding region and the other is situated downstream of the divergently transcribed P2 of *ahpC*. Thus, the regulation of *ahpC* and *oxyR* expression in *M. leprae* may share some similarities with the case in *E. coli*, suggesting a complex regulation of *ahpC* and *oxyR* in this organism (Dhandayuthapani *et al.*, 1997). *M. smegmatis ahpC* appears to be transcribed from a single promoter since S1 nuclease protection experiments detect two mRNA 5' endpoints at 48 and 54 bp upstream of the *ahpC* start codon (Dhandayuthapani *et al.*, 1996).

AhpC expression is H<sub>2</sub>O<sub>2</sub>-inducible in *M. avium*, *M. marinum* and *M. xenopi* and cumene hydroperoxide inducible in *M. marinum* (Sherman *et al.*, 1995; Dhandayuthapani *et al.*, 1997; Pagan-Ramos *et al.*, 1998; Pagan-Ramos *et al.*, 2006). Peroxide inducibility of AhpC expression is OxyR-dependent in *M. marinum* (Pagan-Ramos *et al.*, 2006). *M. smegmatis* AhpC expression is induced by H<sub>2</sub>O<sub>2</sub> and the organic peroxides, cumene and *tert*-butyl hydroperoxide. However, OxyR dependence has yet to be demonstrated (Dhandayuthapani *et al.*, 1996).

In the gram-negative anaerobe, *Porphyromonas gingivalis*, expression of the *ahpC-ahpF* operon is also under OxyR control. Transcription initiates from an *E. coli*  $\sigma^{70}$ -like promoter at a point 38 bp upstream of the *ahpC* start codon (Fig. 2A). A sequence similar to the *E. coli* consensus OxyR binding motif is also present immediately upstream of the -35 promoter element and a DNA fragment spanning this regions binds *P. gingivalis* OxyR (Ohara *et al.*, 2006). The operon is transcribed as a predominant mRNA of approximately 600 nucleotides encoding *ahpC* and a less abundant larger transcript of approximately 2400 to 2700 nucleotides encoding *ahpC* and *ahpF* (Diaz *et al.*, 2004; Johnson *et al.*, 2004; Ohara *et al.*, 2006). RT PCR analysis also suggests the presence of a promoter downstream of *ahpC* driving transcription of *ahpF* (Johnson *et al.*, 2004). Inactivation of OxyR results in a lack of AhpC induction by either H<sub>2</sub>O<sub>2</sub> or the superoxide generator, paraquat, as determined by 2-D gel electrophoresis of *P. gingivalis* crude extracts. In addition to

H<sub>2</sub>O<sub>2</sub> and paraquat, AhpC expression in *P. gingivalis* is also induced upon exposure of this anaerobe to O<sub>2</sub> (Diaz *et al.*, 2004; Ohara *et al.*, 2006; Okano *et al.*, 2006). *ahpC* promoter-*lacZ* fusion and Northern blotting studies confirm that regulation occurs at the level of transcription (Ohara *et al.*, 2006).

In the related enteric anaerobe, *Bacteroides fragilis*, the *ahpC-ahpF* operon initiates at a point 37 bp upstream of the *ahpC* translation start. An abundant transcript of approximately 600 nucleotides, encoding *ahpC*, has been identified in northern blots along with a less abundant 2400 nucleotide mRNA encoding *ahpC* and *ahpF* (Rocha and Smith, 1998; Rocha and Smith, 1999). An additional 1700 nucleotide message, encoding *ahpF*, is also present indicating that *ahpF* is likely to be expressed independently of *ahpC* from its own promoter (Rocha and Smith, 1999) (Fig. 2A). Northern blots, combined with analyses of strains carrying *ahpC* promoter-*xylB* fusions, reveal that *ahpC* expression is induced upon exposure to H<sub>2</sub>O<sub>2</sub> and oxygen and that induction is *oxyR* dependent (Rocha and Smith, 1998; Rocha and Smith, 1999; Rocha *et al.*, 2000).

The *ahpC* operon of the gram-positive soil bacterium, *Streptomyces coelicolor*, resembles those of certain mycobacterial strains in that *ahpC* is flanked downstream by *ahpD* and upstream by a divergently transcribed *oxyR* (Fig. 2A). Expression and mutagenesis studies by Hahn *et al.* (2002) revealed that *ahpC* and *ahpD* are co-transcribed on a 1200 nucleotide mRNA from a point 63 bp upstream of the *ahpC* start codon and sequence elements resembling a consensus E $\sigma^{\text{hrdB}}$ -type consensus promoter are found at the appropriate positions upstream. Divergent transcription of *oxyR* initiates 35 and 39 bps upstream of the *ahpC* transcription start from an E $\sigma^{\text{hrdB}}$ -type consensus promoter that overlaps the *ahpC* promoter. AhpC expression in *S. coelicolor* shows growth phase dependence during normal aerobic growth with high expression early in exponential phase that trails off as the culture approaches late exponential and stationary phase. Expression is also induced in response to H<sub>2</sub>O<sub>2</sub> exposure. Oddly enough, *oxyR* shows the same pattern of transcriptional regulation as *ahpC* and in each case H<sub>2</sub>O<sub>2</sub> dependent induction is lost upon inactivation of *oxyR*.

## 2.2. PerR Mediated Regulation of AhpC

The peroxide-sensing regulator PerR is a member of a family of small dimeric metal-responsive transcriptional repressors (Mongkolsuk and Helmann, 2002). Initially identified in *Bacillus subtilis* as the primary regulator of peroxide stress-inducible genes (Chen *et al.*, 1995; Bsat *et al.*, 1996; Bsat *et al.*, 1998; Mostertz *et al.*, 2004), PerR homologs have since been identified in both gram-positive and gram-negative bacteria (Herbig and Helmann, 2001). A model of PerR gene regulation is shown in Fig. 3. In its active form, PerR monomers contain one Zn<sup>2+</sup> ion bound at a structural site and one Fe<sup>2+</sup> ion bound to a regulatory site. Fe<sup>2+</sup> and Zn<sup>2+</sup> containing PerR binds DNA at the “Per Box” sequence motif: TTATAATNATTATAA (Fuangthong and Helmann, 2003). In PerR regulated promoters, one or more “Per Boxes” are situated either slightly upstream or over-lapping the promoter. These act as high

### Mechanism of PerR mediated repression

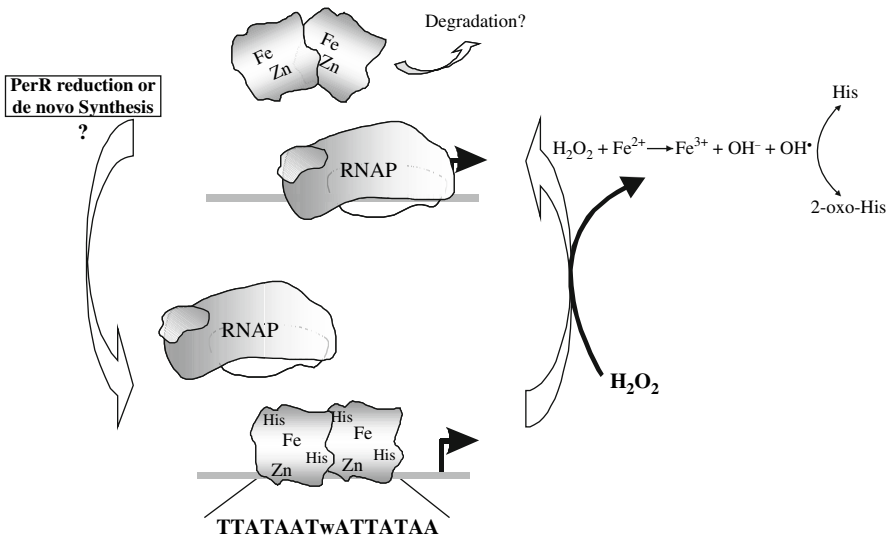

*Figure 3.* Model of PerR mediated repression. Under non-oxidizing conditions PerR binds to target promoters and blocks RNA polymerase access. In the presence of peroxide, iron catalyzed of that His residues that coordinate iron bound by PerR. This induces structural changes that render PerR incapable of binding DNA, thus allowing RNA polymerase access to the promoter. The fate of oxidized PerR is not known. It may be re-reduced or subject to degradation followed by *de novo* synthesis of PerR

affinity nucleation sites for cooperative binding of PerR extending downstream that blocks the promoter. Peroxide exposure renders the protein incapable of DNA binding thus freeing the target promoter to bind RNA polymerase. The metals  $Co^{2+}$ ,  $Ni^{2+}$  and  $Mn^{2+}$  are able to replace  $Fe^{2+}$  at the regulatory site and still retain DNA binding activity. While PerR containing  $Fe^{++}$  is extremely sensitive to peroxide, PerR containing  $Mn^{++}$  is much more resistant to peroxide inactivation. The observed resistance of  $Mn^{++}$  containing PerR to peroxide inactivation appears to be physiologically relevant since the level of  $H_2O_2$  induction of a PerR-regulated *katG* promoter-*lacZ* fusion was reduced by supplementation of the growth media with  $Mn^{2+}$  compared to that with  $Fe^{2+}$ . Thus PerR senses peroxide levels as well as the level of  $Fe^{2+}$  and  $Mn^{2+}$  in the cell.

Peroxide-mediated inactivation of PerR was initially thought to be due to thiol oxidation, because the DNA binding activity of peroxide-treated PerR could be restored *in vitro* by the addition of DTT (Herbig and Helmann, 2001). However, a recent report has shown that this is not the case and that PerR inactivation is due to oxidation at critical histidine residues (Lee and Helmann, 2006). Molecular modeling of PerR indicates that the structural  $Zn^{++}$  ion in each PerR monomer is coordinated by the cysteine residues; C96, C99, C136 and C139, while the regulatory

Fe<sup>++</sup> is bound to a pocket by the histidine residues; H37, H91 and H93 and the aspartate residues, D85 and D104. Site directed mutagenesis of these residues indicates that they were all required for *in vitro* activation of a *mrgA*-promoter-*lacZ* fusion. Moreover, electrospray ionization-mass spectrometry (ESI-MS) of H<sub>2</sub><sup>18</sup>O<sub>2</sub> treated full length PerR and its tryptic digestion fragments determined that inactivation was due to oxidation of either H37 or H91.

PerR has been identified as the regulator of peroxide-inducible *ahpC* expression in *Bacillus subtilis*, *Campylobacter jejuni* and *Staphylococcus aureus* and the transcriptional organization of the *ahpC* operons in these organisms is shown in Fig. 2B.

PerR gene regulation has been extensively studied in *Bacillus subtilis* where PerR has been shown to regulate the peroxide-inducible expression of many genes (Helmann *et al.*, 2003; Mostertz *et al.*, 2004). Among these are genes involved in oxidative stress defense such as *kataA*, a major vegetative catalase, *mrgA*, encoding an oxidative stress inducible DNA binding protein, and the *ahpCF* operon (Chen *et al.*, 1995; Bsat *et al.*, 1996). Antelmann *et al.* (1996) determined that the *B. subtilis ahpCF* operon is transcribed on a 2400 nucleotide mRNA. A second smaller *ahpC* hybridizing message was detected that was not characterized, leaving open the possibility that *ahpC* is also transcribed on a monocistronic mRNA (Fig. 2B). Transcription was found to initiate from a *B. subtilis*  $\sigma^A$ -RNA polymerase consensus promoter at a site 64 nucleotides upstream of the *ahpC* translation start. DNaseI foot printing revealed that PerR represses *ahpC* transcription through direct binding to a region that spans the -10 and -35 consensus promoter elements, as well as the transcription start, and contains three "Per Box" consensus binding motifs (Herbig and Helmann, 2001).

Consistent with results of *in vitro* DNA binding studies, PerR repression of *ahpC* expression in *B. subtilis* requires the presence of either Fe<sup>2+</sup> or Mn<sup>2+</sup>, as growth in minimal media lacking these metals leads to *ahpC* induction (Bsat *et al.*, 1996; Fuangthong *et al.*, 2002b). Transcription and proteomic studies indicate that *ahpC* expression is most effectively up-regulated by oxidative stress inducers such as: H<sub>2</sub>O<sub>2</sub>, the superoxide generator paraquat and, to a lesser degree, organic hydroperoxides (Antelmann *et al.*, 1996; Bsat *et al.*, 1996; Bernhardt *et al.*, 1997; Helmann *et al.*, 2003; Mostertz *et al.*, 2004). Other general stresses such as: heat, high salt, ethanol exposure, glucose starvation and entry into stationary phase also induce *ahpC* expression, but to a lesser degree than oxidative stress (Antelmann *et al.*, 1996; Bsat *et al.*, 1996; Bernhardt *et al.*, 1997; Hoper *et al.*, 2006). The fact that these responses were independent of the general stress sigma factor ( $\sigma^B$ ), a counterpart to *E. coli*  $\sigma^S$ , indicates that *ahpC* induction is a secondary response resulting from oxidative stress generated by the various general stresses (Bernhardt *et al.*, 1997; Hecker and Volker, 2001).

In the microaerophilic bacterium *Campylobacter jejuni*, *ahpC* is flanked upstream by a divergently transcribed ferredoxin gene, *fdxA*, and downstream by *flhB*, encoding a structural component of the flagella (Fig. 2A). No *ahpF* homolog is present in the genome of this organism and *ahpC* is transcribed from a *C. jejuni*  $\sigma^{70}$ -consensus promoter initiating at a point 31 bp upstream of the translation start



(Baillon *et al.*, 1999). PerR regulation is demonstrated by the fact that *C. jejuni* *ahpC*, along with *kataA*, is derepressed in a *perR* mutant (van Vliet *et al.*, 1999). SDS PAGE of cell extracts, as well as *ahpC*-promoter *lacZ* fusion studies, indicate that *C. jejuni* *ahpC* expression shows the typical iron-dependent repression observed in *B. subtilis* indicating that PerR-mediated regulation in the two organisms is similar (Baillon *et al.*, 1999; van Vliet *et al.*, 1999).

Like the situation in *B. subtilis*, PerR in *Staphylococcus aureus* also regulates the transcription of genes encoding proteins involved in the oxidative stress response such as: KatA (catalase), the peroxiredoxin Bcp (Bacterioferritin co-migratory protein), TrxB (Thioredoxin reductase), the DNA binding protein, MrgA, and AhpCF (Horsburgh *et al.*, 2001). The *S. aureus* *ahpCF* operon gives rise to two transcripts; a 2100 nucleotide message encoding *ahpCF* and a 600 nucleotide message encoding *ahpC* only (Morrissey *et al.*, 2004) (Fig. 2B). Transcription is initiated from an *E. coli*-like  $\sigma^{70}$ -consensus promoter at a point 81 bp upstream of the *ahpC* translation start. A sequence similar to the Per Box DNA binding motif is present 2 bp downstream of the transcription start (Horsburgh *et al.*, 2001). Transcription of *ahpC* is induced by high levels (500  $\mu$ M) of  $H_2O_2$  and by osmotic shock with either sucrose or NaCl (Armstrong-Buisseret *et al.*, 1995; Horsburgh *et al.*, 2001). Hypochlorous acid (HClO) is also an inducer of *ahpC* expression that is probably due to the induction of oxidative stress since the extent of *ahpC* expression correlates inversely with the level of superoxide dismutase (Sod) activity (Maalej *et al.*, 2006). The regulation of *S. aureus* *ahpC* in response to metals differs from that of PerR regulated genes in *B. subtilis*. As in *B. subtilis*,  $Mn^{2+}$  repressed AhpC expression in *S. aureus* but, unlike the case in *B. subtilis*,  $Fe^{2+}$  induced *S. aureus* *ahpC* expression rather than repressing it (Morrissey *et al.*, 2004). The reason for this is not known. However, *S. aureus* PerR also controls the expression of the iron-dependent repressor Fur and the iron acquisition protein ferritin (Ftn), and this may affect iron-mediated PerR regulation (Horsburgh *et al.*, 2001; Morrissey *et al.*, 2004).

### 2.3. HypR Mediated Regulation of AhpC

Recently, a new regulator of oxidative stress related genes has been isolated and characterized in the gram-positive enteric bacterium *Enterococcus faecalis* (Verneuil *et al.*, 2004a; Verneuil *et al.*, 2004b). HypR is a member of the LysR family of positive transcriptional regulators and is involved in the activation of the expression of several genes encoding oxidative stress-associated proteins, including: superoxide dismutase, catalase, glutathione reductase, thioredoxin reductase, a PerR homolog and AhpCF in response to  $H_2O_2$  exposure (Verneuil *et al.*, 2005).

The *ahpC-ahpF* operon of *E. faecalis* is transcribed as a 2.5 nucleotide mRNA that probably encodes *ahpC* and *ahpF* as well as a smaller more abundant mRNA that likely encodes only *ahpC* (Fig. 2C). HypR mediated regulation of the *ahpCF* operon is somewhat unusual in that HypR appears to be necessary in maintaining expression levels during oxidative stress. Exponential phase growth of *E. faecalis*

in aerobic non-shaking cultures results in significant levels of *ahpCF* transcription and addition of H<sub>2</sub>O<sub>2</sub> (2.4 mM) does not result in a further increase in *ahpCF* expression (Verneuil *et al.*, 2004b). Inactivation of *hypR* has little or no effect on aerobic expression of *ahpCF*; however, expression in the presence of H<sub>2</sub>O<sub>2</sub> is reduced approximately 6-fold (Verneuil *et al.*, 2005). The regulatory effect of HypR is the result of direct binding to the *ahpCF* promoter region; however, the exact mechanism of H<sub>2</sub>O<sub>2</sub> dependent activation is unknown. The HypR amino acid sequence is approximately 23% identical to OxyR of *E. coli*, but HypR does not contain any cysteines indicating that its mechanism of activation is not similar to that of OxyR (Verneuil *et al.*, 2004a). It is of interest to note that *E. faecalis* also possesses a PerR homolog, although it appears to play no role in the repression of *ahpCF* expression during normal exponential phase growth (Verneuil *et al.*, 2005).

#### 2.4. AhpC Systems of Indeterminate Regulatory Mechanism

In the gastric pathogen *Helicobacter pylori*, as well as other pathogenic *Helicobacter* species, *ahpC* is transcribed on a 700 nucleotide monocistronic mRNA (Lundström and Bolin, 2000; Lundström *et al.*, 2001) (Fig. 2D). Transcription initiates 94 and 96 bp upstream of the *ahpC* start codon from a *Helicobacter*  $\sigma^{70}$ -like promoter (Baker *et al.*, 2001). Expression of *H. pylori* *ahpC* is repressed under acidic growth conditions and induced during growth at pH values greater than 7.0 (Lundström and Bolin, 2000; Slonczewski *et al.*, 2000). Although the *ahpC* promoter region contains several inverted repeat sequences that could serve as binding sites for regulators (Baker *et al.*, 2001), to date, no *ahpC* regulatory protein(s) have been identified in this organism. *H. pylori* does contain a *fur* homolog, however, proteomic analysis of an *H. pylori* *fur* mutant did not detect increased expression of AhpC (Gancz *et al.*, 2006). Moreover, homology searches of the *H. pylori* genome using the sequences of the known *ahpC* regulators; OxyR of *Mycobacterium marinum* and *E. coli*, HypR of *Enterococcus faecalis* and PerR of *B. subtilis*, failed to detect any homologs (Baker *et al.*, 2001; Dubbs and Mongkolsuk, personal observations).

In *Mycobacterium tuberculosis* and other members of the *M. tuberculosis* complex, such as the pathogenic strains of *Mycobacterium bovis*, *oxyR* is an inactive pseudogene due to the acquisition of multiple point mutations and deletions (Deretic *et al.*, 1995). As a result, expression of *ahpC* in *M. tuberculosis* is quite low (Dhandayuthapani *et al.*, 1996). This is of clinical interest due to the fact that loss of OxyR regulated *ahpC* expression results in the compensatory activation of a catalase encoded by *katG*. This increased expression of catalase renders the organism more susceptible to the antibiotic isoniazid, which must first undergo a catalase-dependent modification in order to acquire antimicrobial activity (Zhang *et al.*, 1992; Rozwarski *et al.*, 1998; Zhao *et al.*, 2006). *M. tuberculosis* strains frequently acquire isoniazid resistance through mutations that inactivate or reduce *katG* expression. In these strains it is often found that secondary mutations are present that increase the expression of *ahpC* (Sherman *et al.*, 1999).

In *M. bovis*, and probably *M. tuberculosis*, the *ahpCD* operon is transcribed from a single promoter initiating from a point 42 bp upstream of the *ahpC* start codon (Dhandayuthapani *et al.*, 1996; Zhang *et al.*, 1996; Wilson *et al.*, 1998) (Fig. 2D). In spite of the absence of functional OxyR, *ahpC* still shows some level of regulated expression in *M. tuberculosis* and pathogenic *M. bovis* strains suggesting the presence of an additional regulator(s) of *ahpC* in these strains. Several lines of evidence point to the existence of a repressor of *ahpC* expression. In *M. tuberculosis*, AhpC synthesis is induced upon static growth (i.e. unshaken cultures incubated in air) but not in oxygenated (i.e. shaken) cultures. Expression is also absent during growth in macrophages. Evidence for the existence of a repressor comes from the observation that strains containing a plasmid borne DNA fragment spanning the *ahpC* promoter/operator region show increased expression of *ahpC* (Springer *et al.*, 2001). Strains of *M. tuberculosis* and *M. bovis* have also been isolated that display increased *ahpC* expression yet contain no promoter mutations (Zhang *et al.*, 1996; Springer *et al.*, 2001). The putative repressor has yet to be identified; however, it is known that *furA*, encoding an oxidative stress-responsive repressor of *katG*, plays no role in *ahpC* regulation since a *furA* mutant of *M. tuberculosis* does not display increased expression of AhpC (Pym *et al.*, 2001).

*M. bovis* BCG carries a missense mutation in *furA* that results in constitutive KatG expression. In addition, the strain has acquired a secondary mutation(s) that results in increased *ahpC* expression. The secondary mutation(s) does not occur in the *ahpC* promoter and results in the expression of *ahpC* under conditions where it is normally repressed, such as during static growth or growth within macrophages (Springer *et al.*, 2001). Studies in this organism also point to the existence of additional regulators of *ahpC* since AhpC synthesis and *ahpC* transcription increase 3-fold and 5-fold, respectively, in response to thiol stress induced by diamide (Dosanjh *et al.*, 2005). It is interesting to note that, even though *ahpC* is constitutively expressed in *M. bovis* BCG, strains containing a plasmid carrying an *M. tuberculosis* DNA fragment that encodes the *ahpC* promoter/operator region show increased levels of AhpC indicating that some level of repression still occurs in *M. bovis* BCG (Springer *et al.*, 2001).

Two other regulators have been implicated in the control of *ahpC* expression in *M. tuberculosis* although the exact nature of the regulatory link, either direct or indirect, is not known. The first, OxyS (Not to be confused with the small regulatory RNA first identified in *E. coli*), is a LysR-type transcriptional regulator that has ~29% amino acid sequence identity to *E. coli* OxyR, but does not contain the conserved Cys-8X-Cys motif necessary for redox sensing in OxyR. OxyS is found in members of the *M. tuberculosis* complex and a number of other saprophytic and pathogenic *Mycobacteria* (Domenech *et al.*, 2001). Evidence supporting a role for OxyS in *ahpC* regulation comes mainly from the observation that over-expression of OxyS in *M. tuberculosis* represses AhpC levels. The fact that inactivation of *oxyS* has no observable effect on the levels of AhpC has led to speculation that OxyS is not the primary regulator of *ahpC* in *M. tuberculosis* (Domenech *et al.*, 2001).

The second potential regulator of *ahpC* in *M. tuberculosis* is a member of the cAMP receptor (CRP)-FNR family of proteins encoded by *rv3676* (Rickman *et al.*, 2005). Inactivation of *rv3676* results in a 3.6-fold decrease in *ahpC* transcription, as determined by microarray analysis, indicating a positive regulatory role for *rv3676*. The presence of a sequence similar to the *E. coli* Crp consensus binding site, TGTGA-N<sub>6</sub>-CACAA, in the *M. tuberculosis ahpC* promoter operator region lends support to the notion that *rv3676* may be a direct regulator of *ahpC*; however, *rv3676* binding to the *ahpC* promoter/operator has yet to be demonstrated. Based on the phenotype of the *rv3676* and the menu of genes it is known to regulate it is thought that *rv3676* may be a global regulator controlling persistence and reactivation during *M. tuberculosis* infections (Rickman *et al.*, 2005).

In *Corynebacterium diphtheriae* the organization of the operon encoding the AhpC homolog *DirA* is similar to that found in *S. coelicolor* and *Mycobacteria*, such as *M. avium*, in that *dirA* is closely linked to a downstream *ahpD* with a divergently transcribed *oxyR* upstream (Fig. 2D). Based solely on the gene organization it is likely that *dirA* expression is under OxyR control; however, this has not been demonstrated. One study by Tai and Zhu (1995) indicates that *DirA* expression is induced under conditions of low iron attained through the addition of an iron chelator to the culture medium. This suggests that *dirA* expression may be under the control of an iron-dependent repressor. Bioinformatic analyses of the *C. diphtheriae* genome sequence by Brune *et al.* (2005) to identify transcriptional regulators indicate that the *C. diphtheriae* genome contains a gene encoding the iron dependent repressor, *DtxR*. While a *dtxR* mutant of *C. diphtheriae* is less resistant to H<sub>2</sub>O<sub>2</sub> (Oram *et al.*, 2002), indicating some link between *dtxR* and oxidative stress, at this point there is no evidence that *DtxR* regulates *dirA*.

AhpC regulation has been examined in several strains of *Streptococci*. These gram-positive members of the Lactic acid bacteria are facultative anaerobes and have the ability to tolerate the presence of air to varying degrees. However, they do not synthesize hemes and therefore do not produce cytochromes, cytochrome oxidases or catalase (Dolin, 1961). Due to the lack of cytochrome oxidase, under aerobic conditions these organisms utilize NADH oxidases to shuttle excess reducing equivalents to O<sub>2</sub> to form either H<sub>2</sub>O<sub>2</sub> or H<sub>2</sub>O and regenerate NAD<sup>+</sup> (Higuchi *et al.*, 2000; Poole *et al.*, 2000a). Consequently, H<sub>2</sub>O<sub>2</sub> detoxification mechanisms are crucial.

AhpC expression has been characterized in the pathogen, *Streptococcus pyogenes*, and the organisms involved in dental plaque and dental caries formation; *Streptococcus mutans* and *Streptococcus gordonii*. Both the *S. pyogenes* and *S. mutans ahpC* operons display the typical *ahpC-ahpF* gene organization (King *et al.*, 2000; Poole *et al.*, 2000a) (Fig. 2D). The *ahpC* transcription start of *S. pyogenes* has been mapped to a point 26 bp upstream of the *ahpC* start codon (King *et al.*, 2000). Studies of *ahpC* transcription patterns in *S. pyogenes* suggest that *ahpC* is not part of the inducible oxidative stress response of the organism, but is regulated in response to growth phase. An aerobically grown *S. pyogenes* strain containing an *ahpC* promoter-alkaline phosphatase fusion did not show increased *ahpC* promoter activity when challenged with either H<sub>2</sub>O<sub>2</sub>, cumene hydroperoxide, methyl viologen

or ethanol (King *et al.*, 2000). However, a study monitoring *ahpC* transcript levels in aerobic cultures using quantitative real time PCR indicates that *ahpC* is expressed at a low level during exponential phase and induced nearly seven-fold during stationary phase (Brenot *et al.*, 2005).

The regulator(s) of *ahpCF* in *S. pyogenes* has not been identified. Growth phase regulation would suggest the involvement of a stress inducible sigma factor such as  $\sigma^B$  of *B. subtilis*; however, Blast searches of the *S. pyogenes* genome sequence, as well as attempts to PCR amplify gene-internal fragments of *sigB* and the genes encoding the  $\sigma^B$  accessory proteins RsbU and RsbW, failed to detect any homologs (King *et al.*, 2000). Both *S. pyogenes* and *S. mutans* also possess a gene encoding a PerR homolog (King *et al.*, 2000; Dubbs and Mongkolsuk, personal observations). However, PerR is not involved in the regulation of *ahpC* in *S. pyogenes*, since inactivation of *perR* has no significant effect on the expression of *ahpC* either during exponential or stationary phase growth (King *et al.*, 2000; Brenot *et al.*, 2005).

*Streptococcus gordonii* is a contributor to oral biofilm formation with a unique organization of *ahpC* and *ahpF* (Fig. 2D). In this organism both *ahpC* and the *ahpF* homolog, *nox*, are oriented in the same direction on the genome with *nox* positioned downstream of *ahpC*. Inserted between *ahpC* and *nox*, in the opposite orientation, is an operon believed to be involved in oxidative stress resistance containing *nosX*, encoding a nitric oxide reductase maturation factor, and *qor1* and *qor2*, each encoding a quinone oxidoreductase (Loo *et al.*, 2004).

Nothing is known of the regulatory mechanism controlling *ahpC* and *nox* in *S. gordonii*; however, expression data do indicate a role in oxidative stress defense. Quantitative real-time RT PCR analyses by Loo *et al.* (2004) reveal that transcription of *S. gordonii ahpC* is induced under aerobic conditions 3.8 to 4.7-fold in shaken and static cultures, respectively, relative to transcript levels in anaerobic cultures. Like *ahpC*, *nox* transcription is induced during aerobic growth in both static (9.7-fold) and shaking (38.9-fold) cultures although the induction levels are significantly higher. The regulation of the two genes differs greatly during growth in biofilms. Anaerobic growth as a biofilm has no effect on *ahpC* expression relative to planktonic cells grown under the same conditions. However, *nox* transcript levels jumped 7 to 9.9-fold during growth as a biofilm. Thus the lack of an operonal organization of *ahpC* and *nox*, as well as their differing regulatory pattern during growth as a biofilm, may reflect an additional physiological role for *nox* in this organism.

The *Legionella pneumophila*, *ahpCD* operon is linked to an upstream *orf* predicted to encode a glutaredoxin-like protein (*grlA*) (Rankin *et al.*, 2002) (Fig. 2D). While the function of *grlA* is unknown, studies using *lacZ*-transcriptional fusions, to a region immediately downstream of *ahpC*, including sequences 5' to *grlA*, indicate that *grlA* is probably co-transcribed with *ahpC* with the message terminating at a stable hairpin downstream of *AhpC* (Rankin *et al.*, 2002). *AhpD* is likely to be transcribed as result of partial read through of this terminator although no detailed characterization of the transcripts has been performed to confirm this. No information is available concerning the mechanism of *ahpC* regulation in this

organism; however, homology searches of the *L. pneumophila* str. Paris genome show that it encodes an OxyR homolog (lpp1778) as well as two PerR/Fur homologs (lpp0438, lpp0302) (Dubbs and Monkolsuk, personal observations).

Finally, an *ahpC* homolog has been characterized in *Shewanella putrefaciens*, a gram-negative organism involved in the spoilage of refrigerated foods. This particular homolog is transcribed on a 600 bp monocistronic mRNA and AhpC expression is induced upon exposure to cold temperatures (2.6-fold at 4°C) and osmotic shock (11-fold after 45 min in 1.5% NaCl) (Leblanc *et al.*, 2003). Examination of the genome sequence reveals the presence of an AhpF homolog 111 bp downstream of AhpC (Dubbs and Mongkolsuk personal observations), but no bicistronic *ahpCF* message has yet been detected (Fig. 2D). Homology searches of the partial *Shewanella putrefaciens* CN-32 genome sequence against the known oxidative stress regulators; OxyR of *E. coli*, HypR of *E. faecalis* and PerR of *B. subtilis*, identified a single PerR homolog, Sputcn32\_07245 (~30% sequence identity).

## 2.5. Physiological Role of AhpC

### 2.5.1. Physiological substrate: H<sub>2</sub>O<sub>2</sub>

*In vitro*, AhpC has been shown to have a wide substrate range including H<sub>2</sub>O<sub>2</sub>, simple and complex organic peroxides, as well as reactive nitrogen intermediates (RNI) such as peroxyxynitrite (Bryk *et al.*, 2000; Baker *et al.*, 2001). Given this and the fact that AhpC homologs are widely distributed among prokaryotes, what then are the physiological substrates for AhpC and what protective role(s) does AhpC play *in vivo*? Genetic and physiological studies have yielded evidence indicating that H<sub>2</sub>O<sub>2</sub>, organic peroxides and RNI may all be physiologically relevant substrates for AhpC. Interpretation of data obtained through the analyses of *ahpC* null mutants and AhpC over-expressing strains have been complicated by the redundant nature of oxidative stress defense mechanisms in bacteria, where alterations in the levels of one component can result in compensatory alterations in the expression of other stress protective genes. These other genes are often, but not always, controlled by the same stress responsive regulator(s). This can give rise to phenotypes that are sometimes the opposite of what might be expected. This is particularly evident in studies investigating the role of AhpC in H<sub>2</sub>O<sub>2</sub> detoxification. For instance, a *P. gingivalis ahpC* mutant is, as expected, more sensitive to H<sub>2</sub>O<sub>2</sub> relative to wild type (Johnson *et al.*, 2004); however, this appears to be the exception rather than the rule. Inactivation of bacterial *ahpC* usually has little or no effect on H<sub>2</sub>O<sub>2</sub> resistance as demonstrated in *M. tuberculosis* (Springer *et al.*, 2001), *C. jejuni* (Baillon *et al.*, 1999), *B. fragilis* (Rocha and Smith, 1999), *S. pyogenes* (King *et al.*, 2000), *S. mutans* (Higuchi *et al.*, 1999), *S. typhimurium* and *E. coli* (Storz *et al.*, 1989; Francis *et al.*, 1997; Seaver and Imlay, 2001). In some cases *ahpC* mutants are actually hyper-resistant to H<sub>2</sub>O<sub>2</sub> as is the case with *X. campestris* (Loprasert *et al.*, 2000; Mongkolsuk *et al.*, 2000a; Charoenlap *et al.*, 2005), *P. aeruginosa* (Ochsner *et al.*, 2000) and *B. subtilis* (Antelmann *et al.*, 1996; Bsath *et al.*, 1996).

The increase in H<sub>2</sub>O<sub>2</sub> resistance in *ahpC* mutants in *E. coli* (Seaver and Imlay, 2001), *P. aeruginosa* (Ochsner *et al.*, 2000), *B. fragilis* (Rocha and Smith, 1999), *X. campestris* (Loprasert *et al.*, 2000; Mongkolsuk *et al.*, 2000a; Mongkolsuk *et al.*, 2000b; Charoenlap *et al.*, 2005) and *B. subtilis* (Bsat *et al.*, 1996) results primarily from the increased expression of catalase. Other oxidative stress protective factors can also play a role. For instance in the catalase-negative organism *S. mutans* induction of the iron binding DNA protecting protein, Dpr, has been shown to be responsible for maintaining H<sub>2</sub>O<sub>2</sub> resistance in an *ahpC* mutant strain (Yamamoto, 2000a; Yamamoto *et al.*, 2000b). Dpr orthologs are known to contribute to peroxide resistance in other bacteria (Olczak *et al.*, 2002; Loprasert *et al.*, 2004; Brenot *et al.*, 2005; Park *et al.*, 2005) and have been shown to be up-regulated in both *B. subtilis* and *H. pylori ahpC* mutants (Bsat *et al.*, 1996; Olczak *et al.*, 2002).

Over-expression of *ahpC* commonly leads to little or no increase in H<sub>2</sub>O<sub>2</sub> resistance (Storz *et al.*, 1989; Wilson *et al.*, 1998; Manca *et al.*, 1999; Hahn *et al.*, 2002; Loprasert *et al.*, 2003) and this has been shown in several studies to result from compensatory reductions in catalase levels (Manca *et al.*, 1999; Mongkolsuk *et al.*, 2000b; Hahn *et al.*, 2002). It should be noted that over-expression of AhpC from plasmids can result in increased H<sub>2</sub>O<sub>2</sub> sensitivity that appears to be linked to either co-expression of AhpF or titration of regulatory factors due to the presence of promoter sequences on the expression plasmid (Storz *et al.*, 1989; Loprasert *et al.*, 1997; Mongkolsuk *et al.*, 2000b; Fukumori and Kishii, 2001; Charoenlap *et al.*, 2005). This raises the possibility that in some studies *katG* expression may be affected by factors other than high AhpC levels. The fact that the peroxide sensing regulators OxyR and PerR are known to mediate the compensatory responses in *E. coli*, *X. campestris*, and *B. subtilis* (Bsat *et al.*, 1996; Mongkolsuk *et al.*, 1998a; Seaver and Imlay, 2001; Charoenlap *et al.*, 2005) has led to the hypothesis that AhpC is a scavenger of endogenous peroxides and that inactivation of *ahpC* leads to their accumulation to the point that global oxidative stress defense pathways are induced. What then are the endogenous peroxides?

Good evidence implicating H<sub>2</sub>O<sub>2</sub> as the endogenously produced peroxide comes primarily from a careful study by Seaver and Imlay (2001) showing that *E. coli katG* (catalase) and *ahpC* deficient mutants were able to scavenge low levels of H<sub>2</sub>O<sub>2</sub> (1.5 mM) from the growth media equally as well as wild type, while an *ahpC katG* mutant could not. Furthermore, an *ahpC katG* double mutant excreted H<sub>2</sub>O<sub>2</sub> into the culture media during aerobic growth. A final indication that *ahpC* is the “house-keeping” H<sub>2</sub>O<sub>2</sub> scavenger in *E. coli* came from the observation that inactivation of *ahpC*, but not of *katG*, resulted in activation of the OxyR regulon, as measured using a *katG* promoter-*lacZ* fusion. OxyR regulon activation could be halted by the addition of catalase to the culture medium indicating that H<sub>2</sub>O<sub>2</sub> is the probable inducer. This conclusion is supported by work in the gram-negative bacterium *X. campestris* showing that OxyR-mediated activation of an *ahpC* promoter *lacZ* fusion, in an *ahpC* mutant background, was reduced by over-expression of KatA. The lack of induction of the organic peroxide-specific OhrR/Ohr system in an *X. campestris ahpC* mutant argues against the participation of organic peroxides

as inducers (Charoenlap *et al.*, 2005). Also, in the catalase-negative bacterium *Streptococcus pyogenes* inactivation of *ahpC* led to a 60% reduction in the H<sub>2</sub>O<sub>2</sub> scavenging activity of crude cell extracts as well as the accumulation of H<sub>2</sub>O<sub>2</sub> in the culture medium (Brenot *et al.*, 2005). These results support the suggestion by Seaver and Imlay (2001) that AhpC functions as the primary H<sub>2</sub>O<sub>2</sub> scavenger during normal aerobic growth in *E. coli* and that AhpC probably fulfills the same role in other organisms that display compensatory activation of the peroxide regulon upon *ahpC* inactivation.

### 2.5.2. Physiological substrate: Organic peroxides and reactive nitrogen intermediates (Peroxynitrite)

Unlike the case with H<sub>2</sub>O<sub>2</sub> sensitivity, *ahpC* inactivation almost always results in increased sensitivity to organic peroxide exposure (Storz *et al.*, 1989; Antelmann *et al.*, 1996; Francis *et al.*, 1997; Baillon *et al.*, 1999; Rocha and Smith, 1999; Loprasert *et al.*, 2000; Ochsner *et al.*, 2000; Mongkolsuk *et al.*, 2000b; Springer *et al.*, 2001; Olczak *et al.*, 2002; Johnson *et al.*, 2004; Charoenlap *et al.*, 2005) with the only exceptions being *Streptococcus mutans* (Higuchi *et al.*, 1999) and *Agrobacterium tumefaciens* (Chuchue *et al.*, 2006). Conversely, *ahpC* over-expression invariably leads to increased resistance to organic peroxides (Storz *et al.*, 1989; Sherman *et al.*, 1996; Loprasert *et al.*, 1997; Wilson *et al.*, 1998; Fukumori and Kishii, 2001; Hahn *et al.*, 2002; Loprasert *et al.*, 2003; Charoenlap *et al.*, 2005). It is commonly concluded from these phenotypes that AhpC functions as a scavenger of organic peroxides. One criticism of this has been that increased resistance to exogenously added organic peroxides does not necessarily mean that they are an *in vivo* substrate for the enzyme during normal growth (Seaver and Imlay, 2001).

Evidence has been accumulating to indicate that organic peroxides are an important substrate for AhpC *in vivo*. Master *et al.* (2002) found that an *ahpC* mutant of *M. tuberculosis* accumulated higher levels of lipid peroxides than the wild type upon treatment with peroxynitrite. Results by Wang *et al.* (2004) also found that an *H. pylori ahpC* mutant accumulated high levels of lipid peroxides, relative to wild type, during aerobic growth. Furthermore, AhpC protected catalase from a specific organic peroxide mediated inactivation *in vivo*. It was suggested that organic peroxide detoxification is the primary role for AhpC in *H. pylori*. Both studies clearly demonstrate that organic peroxides can form in bacterial cells during oxidative stress and strongly suggest that AhpC directly scavenges organic peroxides. However, they still do not unequivocally indicate to what degree AhpC scavenges lipid peroxides *in vivo* or prevents their formation by detoxifying reactive oxygen species (i.e. H<sub>2</sub>O<sub>2</sub>) or reactive nitrogen species (i.e. peroxynitrite) before they can initiate lipid peroxide formation. It should be noted here that it has been proposed that in *E. coli* lipid peroxide formation may not occur due to the lack of polyunsaturated fatty acids in the membrane (Seaver and Imlay, 2001). Two studies now indicate that lipid peroxides do indeed form in *E. coli* during oxidative stress induced by exposure to either exogenous H<sub>2</sub>O<sub>2</sub> or to reactive oxygen species generated by the illumination of aerobic cultures with UV light in



the presence of titanium oxide (Maness *et al.*, 1999; Semchyshyn *et al.*, 2005). Thus, although AhpC is primarily a scavenger of endogenous H<sub>2</sub>O<sub>2</sub> in *E. coli*, it probably still participates in organic peroxide detoxification during severe oxidative stress.

One mechanism used by macrophages to kill invading bacteria is the production of reactive nitrogen intermediates (RNI) including peroxynitrite (Karupiah *et al.*, 2000; Nathan and Shiloh, 2000). In response, bacteria have evolved strategies to cope with RNI exposure (Zarht and Deretic, 2002) and AhpC appears to be one of the systems used to defend against RNI stress. Chen *et al.* (1998) first demonstrated that a *Salmonella typhimurium* *ahpC* mutant was sensitive to the reactive nitrogen intermediates, peroxynitrite and s-nitrosoglutathione, and that sensitivity could be complemented with plasmid borne *Mycobacterium tuberculosis* *ahpC*. In the same study it was shown that a human epithelial cell line expressing *M. tuberculosis* AhpC was more resistant to either exogenous s-nitrosoglutathione or RNI generated via transfection of the cells with a vector carrying the gene encoding mammalian nitric oxide synthase (*NOS2*) than a cell line not expressing *ahpC*. Subsequent work by Master *et al.* (2002) demonstrated that both *M. tuberculosis* and *M. smegmatis* *ahpC* mutants were more sensitive to RNI (peroxynitrite and s-nitrosoglutathione) than the wild type in culture. The *M. tuberculosis* *ahpC* mutant accumulated higher levels of lipid peroxides in the presence of peroxynitrite than the wild type. The *ahpC* mutant was also found to be less able to survive in unstimulated “resting” macrophages, but not macrophages induced with INF- $\gamma$  and lipopolysaccharide suggesting a defined role for AhpC in resting macrophages. These clear indications that *ahpC* plays a role in defense against RNI have been reinforced by a study in the pathogen, *Burkholderia pseudomallei*, showing that AhpC over-expression also results in increased resistance to RNI (Loprasert *et al.*, 2003).

### 2.5.3. Role of AhpC in virulence

Several lines of evidence point to AhpC as a virulence factor in several organisms. Investigations in animal models, as well as in human patients, show that infection with *S. typhimurium*, *H. pylori* and several *Mycobacteria* elicit strong immune responses against AhpC (Elsaghier *et al.*, 1992; Yamaguchi *et al.*, 1992; Taylor *et al.*, 1998; Olsen *et al.*, 2000; Olsen *et al.*, 2001; Windle *et al.*, 2006). Also, AhpC expression is induced in response to intracellular growth in: *Salmonella*, *E. coli*, *Chlamydia* and *Legionella*. Proteomic analyses of *Chlamydia pneumoniae* during persistent infection of a HeLa-derived cell line and *ahpC* promoter-*lacZ* fusion analyses in *Legionella pneumophila* during growth in a human macrophage-derived cell line, detected transient induction of AhpC during the initial stage of infection (Rankin *et al.*, 2002; Mukhopadhyay *et al.*, 2004). A similar analysis of expression from an *ahpC*-promoter *Mudlux* fusion during growth of *Salmonella typhimurium* in a mouse macrophage derived cell line showed the same transient AhpC induction that could be partially blocked by the addition of catalase, thus implicating H<sub>2</sub>O<sub>2</sub> as an inducer (Francis and Gallagher, 1993; Francis *et al.*, 1997). Similarly, *E. coli* *ahpCF* transcription is induced in response to phagocytosis by neutrophils and the

level of induction is reduced in oxidase-deficient neutrophils, again implicating  $H_2O_2$  as an inducer (Staudinger *et al.*, 2002).

Studies measuring the contribution of *ahpC* to virulence in other bacterial pathogens give mixed results that vary depending on the organism and experimental system used. Although *ahpC* expression is induced in *L. pneumophila* during intracellular growth, an *ahpC* insertion mutant grew as well as the wild type in macrophages (Rankin *et al.*, 2002). Likewise, inactivation of *ahpC* also had no effect on the survival of either *M. tuberculosis* or *S. typhimurium* in mice and a *P. gingivalis ahpC* mutant was equally as effective at killing mice as the wild type strain (Taylor *et al.*, 1998; Springer *et al.*, 2001; Johnson *et al.*, 2004), all suggesting that *ahpC* is not essential for virulence.

A clear role for AhpC in virulence was demonstrated in *H. pylori* where *ahpC* mutants were unable to colonize the gastric mucosa of mice (Olczak *et al.*, 2003). Several studies in *Mycobacteria* and *Streptococcus* also indicate a role for AhpC in virulence, although, some of the results using different experimental approaches are contradictory. For instance, in *M. bovis*, reduction of *ahpC* expression using antisense constructs reduced the organism's ability to survive in guinea pigs (Wilson *et al.*, 1998), arguing for a role in virulence. Although it should be noted that over-expression of AhpC had no effect on the ability of the closely related organism, *M. tuberculosis*, to survive in monocytes (Manca *et al.*, 1999). Consistent with the result in *M. bovis*, Master *et al.* (2002) found that inactivation of *ahpC* in *M. tuberculosis* caused reduced survival, relative to wild type, in unstimulated macrophages, but not in macrophages that were stimulated with  $\gamma$ -interferon. This led to speculation that AhpC may play a role in intracellular survival during the transition from latency or during transmission to a new host. Virulence studies in *S. pyogenes* by Brenot *et al.* (2005) highlighted the importance of choosing the correct virulence assay when it was found that a *Streptococcus pyogenes ahpC* mutant displayed reduced virulence when assayed using a mouse subcutaneous injection model but not an intraperitoneal injection model. Assays using intramuscular injection of *S. pyogenes* into zebra fish also failed to detect any effect on virulence. Thus the role of AhpC in virulence, in *M. tuberculosis* and *S. pyogenes* at least, appears to be dependent on multiple factors including the location and/or stage of infection.

#### 2.5.4. Role of AhpC in DNA protection

AhpC is involved in protecting DNA from oxidative damage. Early studies in *E. coli* demonstrated that an *oxyR* deletion mutant over-expressing AhpC from a plasmid, as well as chromosomal mutants over-expressing *ahpC*, had decreased rates of spontaneous mutation (Storz *et al.*, 1987; Greenberg and Demple, 1988; Jacobson *et al.*, 1989). Furthermore, both *Bacteroides fragilis* and *Helicobacter pylori ahpC* mutants were also found to have an increased frequency of mutation (Rocha and Smith, 1999; Olczak *et al.*, 2002). When grown under aerobic conditions, the *H. pylori ahpC* mutant showed increased DNA fragmentation, caused by hydroxyl radical-mediated damage to the sugar backbone, and contained higher

levels of 8-oxo-guanine, a common product of the reaction of DNA with peroxides or hydroxyl radical (Wang *et al.*, 2005). Similar phenotypes were observed in both *katA* and *sodB* mutants and the accumulation of DNA damage correlated with increases in intracellular free iron, consistent with damage by radicals generated from peroxides via the Fenton reaction.

#### 2.5.5. Role of AhpC in protection against catalase inactivation

*H. pylori* catalase is also shielded from oxidative stress-induced inactivation by AhpC. Wang *et al.* (2004) found that an aerobically grown *ahpC* mutant had significantly reduced catalase activity relative to the wild-type strain that was not the result of a reduction in protein level and could not be accounted for by the loss of AhpC peroxidase activity. Catalase inactivation correlated with distinct changes in the EPR spectrum of crude extracts indicating changes in the heme environment. Treatment of wild-type cell free extracts with *tert*-butyl hydroperoxide resulted in a degree of catalase inactivation similar to that observed *in vivo* in the AhpC mutant and induced similar changes in the EPR spectra. Furthermore, treatment of extracts with identical concentrations H<sub>2</sub>O<sub>2</sub> had no effect on catalase. This was taken to indicate that the catalase inactivation observed in the mutant was due to the build up of organic peroxides, specifically lipid hydroperoxides and that the AhpC protective effect was due to the detoxification of lipid peroxides. This hypothesis was supported by the fact that lipid peroxide levels in the *ahpC* mutant were three times that in the wild-type.

#### 2.5.6. AhpC as a molecular chaperone

One very interesting recent finding is that *H. pylori* AhpC exerts a protective effect during oxidative stress that is separate from its hydroperoxidase activity. Chuang *et al.* (2006) demonstrated that long-term exposure of purified AhpC to H<sub>2</sub>O<sub>2</sub> (10 mM) *in vitro* resulted in the formation of high molecular weight aggregates with the concomitant loss of peroxidase activity. Similar aggregates were also shown to form *in vivo* upon extended exposure of cultures to high oxygen tension (20%). *In vitro*, the inactive aggregates were shown to possess chaperone activity as judged by their ability to protect insulin from DTT induced unfolding and aggregation. Thus, it was suggested that *H. pylori* AhpC also acts as a chaperone, possibly to prevent or reverse oxidatively induced protein misfolding that occurs during prolonged periods of oxidative stress. It was noted that the ability to function as a chaperone had previously been demonstrated in eukaryotic yeast peroxiredoxins and that sequence comparisons of the *H. pylori* AhpC amino acid sequence with those of other peroxiredoxins revealed that it is more similar to eukaryotic AhpCs than prokaryotic AhpCs. The overall contribution of this activity to oxidative stress defense in *H. pylori* is unknown. Since aggregation upon over-oxidation appears to be a common property of AhpCs it will be interesting to see if other prokaryotic AhpCs share the ability to function as chaperones.

### 3. Tpx: THIOL PEROXIDASE

#### 3.1. Tpx Structure and Biochemistry

The thiol peroxidase, Tpx, sometimes referred to as p20 or scavengase, was initially purified from *E. coli* extracts as a 20 kDa protein that displayed thiol-dependent peroxidase activity (Cha *et al.*, 1995) and has since been found to be widespread among prokaryotes (Wan *et al.*, 1997; Zhou *et al.*, 1997; Rho *et al.*, 2006). Biochemical studies indicate that Tpx has wide substrate specificity and is generally a more efficient peroxidase than AhpC. However, Tpx enzymes from different sources do vary in terms of substrate specificity. For example, *E. coli* Tpx is known to reduce H<sub>2</sub>O<sub>2</sub> and the organic peroxides, t-BOOH, CuOOH, LOOH with greater efficiency than AhpC and shows a distinct preference for organic peroxides over H<sub>2</sub>O<sub>2</sub> (Baker and Poole, 2003; Choi *et al.*, 2003; Cha *et al.*, 2004). *M. tuberculosis* Tpx has a similar substrate range and preference, although it cannot utilize LOOH as a substrate. In addition, *M. tuberculosis* Tpx is known to reduce peroxyntirite (Jaeger *et al.*, 2004; Rho *et al.*, 2006).

Tpx is active in solution as a homodimer (Zhou *et al.*, 1997; Baker and Poole, 2003; Choi *et al.*, 2003; Rho *et al.*, 2006) and catalyzes the reduction of peroxides using thioredoxin as its electron donor and reducing equivalents ultimately derived from NADPH (Cha *et al.*, 1995; Baker and Poole, 2003; Jaeger *et al.*, 2004). Preference for a particular thioredoxin has been observed for Tpx in *E. coli* and *M. tuberculosis*. *E. coli* Tpx shows a strict requirement for Trx1 (Baker and Poole, 2003), while in *M. tuberculosis* Tpx utilizes both TrxC and TrxB, with a slightly higher affinity for TrxB (Jaeger *et al.*, 2004).

Site-directed mutagenesis studies of the *E. coli* and *M. tuberculosis* enzymes have identified two conserved cysteine residues, corresponding to Cys<sub>61</sub> and Cys<sub>95</sub> in the *E. coli* sequence, as the peroxidatic and resolving cysteines, respectively (Cha *et al.*, 1996; Zhou *et al.*, 1997; Baker and Poole, 2003; Choi *et al.*, 2003; Rho *et al.*, 2006). Oxidation of the Tpx Cys<sup>61</sup> by peroxide is followed by a condensation reaction with reduced Cys<sub>95</sub> to form an intramolecular disulfide bond, thus placing Tpx in the class of atypical 2-cys peroxiredoxins (Baker and Poole, 2003).

Three crystal structures of Tpx are available from *E. coli*, *M. tuberculosis* and *Streptococcus pneumoniae* (Choi *et al.*, 2003; Rho *et al.*, 2006). The structures of all three are quite similar showing a hydrogen-bonded homodimer with subunits associated in a head to tail configuration. Each dimer contains two hydrophobic active site pockets on opposite faces of the molecule that are formed by residues from both subunits. Comparison of the structures of oxidized and reduced enzymes revealed that disulphide bond formation results in partial unfolding of the protein exposing the disulphide and possibly facilitating reductant access (Rho *et al.*, 2006). Differences in the structure of the active site pockets have been observed that are consistent with the differing substrate preferences of the *E. coli* and *M. tuberculosis* enzymes. In *E. coli*, the narrow and deep substrate-binding pocket is L-shaped, while that of the *M. tuberculosis* enzyme is slightly larger and T-shaped (Choi *et al.*, 2003; Rho *et al.*, 2006). Although the substrate preference of the *Streptococcal*

Tpx has not been evaluated, the substrate-binding pocket of *S. pneumoniae* Tpx is smaller than those of *E. coli* and *M. tuberculosis* Tpx (Rho *et al.*, 2006). Structural differences between the *E. coli* and *Streptococcal* enzymes are further indicated by the fact that polyclonal anti-sera raised against the *E. coli* enzyme did not cross-react with *S. parasanguis* Tpx and *vice versa* (Spatafora *et al.*, 2002).

### 3.2. Regulation and Physiological Role of Tpx

The gene organization and regulatory pattern of *tpx* also varies among different organisms (Fig. 4A). In *E. coli*, the best-studied example, *tpx* is transcribed as a monocistronic mRNA of about 500 nucleotides. The regulatory mechanism(s) controlling *tpx* expression in *E. coli* is poorly understood. Two reports by Cha *et al.* (1995; 2004) indicated that *tpx* expression was higher in oxygenated cultures (i. e. vigorous shaking). However, work by the same group found that *tpx* expression was not induced upon exposure to peroxides ( $H_2O_2$ , *t*-BOOH, CuOOH), superoxide generators (paraquat) or inducers of thiol stress (diamide), but was expressed constitutively both aerobically and anaerobically (Cha *et al.*, 2004). Induction of *E. coli tpx* expression has also been observed in response to both alkaline and acidic pH in a pattern similar to that of the outer membrane protein OmpX (Stancik *et al.*, 2002).

Studies of *E. coli tpx* mutants confirm that the enzyme plays an important role in oxidative stress defense in this organism. Inactivation of *tpx* resulted in increased sensitivity to the peroxides,  $H_2O_2$ , CuOOH and *t*-BOOH, as well as the  $O_2^{\bullet-}$  generator paraquat (Cha *et al.*, 1996; Cha *et al.*, 2004). In each case the level of sensitivity was greater than that in an *ahpC* mutant (Cha *et al.*, 2004). In addition, a *tpx* mutant displayed other signs of a compromised oxidative stress defense. An *E. coli tpx* strain had a slower aerobic growth rate and higher levels of protein oxidation during both aerobic and anaerobic growth relative to the wild type. Increased levels of protein oxidation, both membrane and cytosolic, were also observed in the presence of oxidative stress inducers, as well as in response to heat treatment. Once again, the extent of oxidation was greater in the *tpx* mutant relative to an *ahpC* strain. Finally, a *tpx* strain was found to accumulate higher levels of lipid peroxides than the wild-type (Cha *et al.*, 2004). The preference of *tpx* for organic peroxide substrates, combined with the fact that *tpx* is localized in the periplasmic space (Cha *et al.*, 1995) has led to the suggestion that that Tpx acts as a constitutive first line defense against peroxides and functions primarily as a periplasmic lipid peroxidase (Cha *et al.*, 2004). A similar function is suggested for *M. tuberculosis* Tpx given that it is present at higher levels than AhpC and is found in culture filtrates, as well as in association with the cell wall (Weldingh *et al.*, 1998; Rosenkrands *et al.*, 2000a; Rosenkrands *et al.*, 2000b; Jaeger *et al.*, 2004). In *Mycobacterium bovis* strain BCG, Tpx is induced in response to thiol stress generated by exposure to diamide thus pointing to possible regulatory differences (Dosanjh *et al.*, 2005).

A. *tpx* Organization

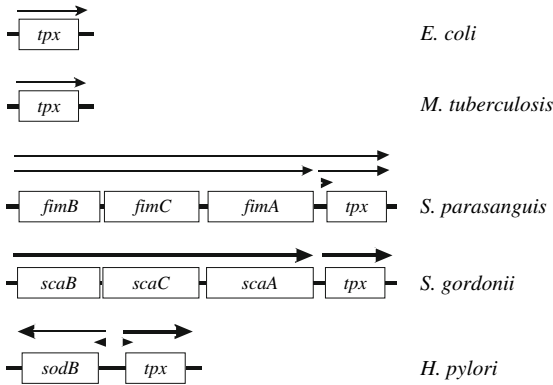

B. *ohr* Organization

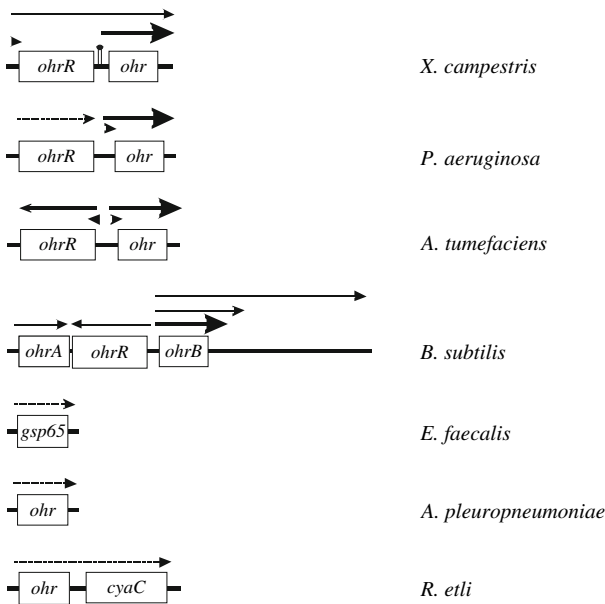

Figure 4. Transcriptional organization of several bacterial *tpx* and *ohr* loci. The transcriptional organization of several *tpx* (A) and *ohr* (B) loci, that are described in the text, are shown. Solid arrows indicate transcripts. The thickness of the arrows reflects their relative abundance. Dashed arrows indicate potential transcripts inferred from the gene organization, as well as any additional information such as the presence of promoters or the positions of mRNA end points. Arrowheads indicate the positions of transcription starts and functional promoters. Lollipops denote transcription terminators

The regulation of *tpx* in several *Streptococci* strains is distinct from that in *E. coli* in that *tpx* expression is oxidative stress-inducible. In *S. parasanguis*, *tpx* is located 77 bp downstream of the *fimBCA* gene cluster encoding an ABC-type metal transporter that has also been implicated in surface adhesion (Spatafora *et al.*, 2002) (Fig. 4A). A similar gene organization also occurs in several other *Streptococci* (Ganeshkumar *et al.*, 1991; Dintilhac and Claverys, 1997; Jakubovics *et al.*, 2002) and Spatafora *et al.* (2002) have shown that *S. parasanguis tpx* is co-transcribed with *fimBCA* on a 3.3 kb mRNA and also on a 500 bp monocistronic message initiated from its own promoter. Both transcripts are present during aerobic, but not anaerobic growth. Attempts to inactivate *tpx* in *S. parasanguis* were unsuccessful and it was suggested that expression of the *fimBCA* metal transporter in the absence of functional *tpx* might result in lethality due to metal catalyzed oxidative stress resulting from iron uptake. However, a *fimA tpx* deletion mutant was found to be more sensitive to  $H_2O_2$  than either the wild type or a *fimA* strain indicating a role for *tpx* in oxidative stress defense (Spatafora *et al.*, 2002).

In *Streptococcus gordonii*, *tpx* is located downstream of the *scaBCA* gene cluster, the equivalent of *fimBCA* (Jakubovics *et al.*, 2002) (Fig. 4A). This transporter is known to be involved in  $Mn^{2+}$  uptake that is necessary for the function of the single Mn-dependent superoxide dismutase (SodA) produced by this organism (Kolenbrander *et al.*, 1998). A single monocistronic *tpx* mRNA has been identified. The *Tpx* expression pattern in *S. gordonii* was similar to that of SodA. Expression of both genes was induced in the presence of  $O_2$ , the  $O_2^{\bullet-}$  generator paraquat, and  $Mn^{2+}$ . Inactivation of *tpx* resulted in increased sensitivity to  $H_2O_2$ , but had no effect on the sensitivity to paraquat. Growth of the mutant under aerobic conditions did not affect the growth rate, but did result in an early entry into stationary phase that was thought to be the result of the build-up of endogenous  $H_2O_2$  (Jakubovics *et al.*, 2002). Thus, in the catalase-negative bacteria, *S. gordonii* and *S. parasanguis*, *tpx* appears to be part of an inducible oxidative stress defense response that includes defense against endogenous  $H_2O_2$ .

Finally, a *tpx* mutant of the gastric pathogen, *Helicobacter pylori* has also been studied (Comtois *et al.*, 2003). In this organism *tpx* is divergently transcribed from *sodB*, encoding an iron containing superoxide dismutase located 222 bp upstream (Fig. 4A), leading to speculation that *sodB* and *tpx* might be co-regulated (Wan *et al.*, 1997). Ernst *et al.* (2005b) found that the iron-responsive regulator, Fur, represses the expression of *sodB* during iron starvation. While *tpx* is highly expressed in *H. pylori* (Jungblut *et al.*, 2000), transcriptional profiling studies indicate that *tpx* is not regulated in response to iron (Ernst *et al.*, 2005a).

The phenotype of an *H. pylori tpx* mutant points to a clear role for *tpx* in oxidative stress defense and as a virulence factor. Comtois *et al.* (2003) found that inactivation of *tpx* in *H. pylori* resulted in increased sensitivity to the peroxides  $CuOOH$  and  $H_2O_2$ , as well as to paraquat. Increased sensitivity of a *tpx* mutant to  $O_2$  has also been observed, but *tpx* inactivation had no effect on resistance to peroxyxynitrite (Comtois *et al.*, 2003; Olczak *et al.*, 2003). Evidence for *tpx* involvement in virulence comes from the fact that an *H. pylori tpx* mutant was significantly impaired in its ability to colonize the stomachs of mice (Olczak *et al.*, 2003).

## 4. Ohr/OsmC PEROXIREDOXIN FAMILY

### 4.1. Ohr (Organic Hydroperoxide Resistance) Structure and Biochemistry

Ohr was first identified in *Xanthomonas campestris* as a gene involved in conferring organic hydroperoxide resistance that did not affect resistance to H<sub>2</sub>O<sub>2</sub> or superoxide generators (Mongkolsuk *et al.*, 1998a). The gene was found to encode a protein of 142 amino acids with a predicted molecular weight of 14.2 kDa that was not similar to any known peroxiredoxins (Mongkolsuk *et al.*, 1998a; Atichartpongkul *et al.*, 2001). Close homologs of Ohr have been identified in a wide variety of bacteria that tend to be plant or animal pathogens (Volker *et al.*, 1998; Atichartpongkul *et al.*, 2001; Shin *et al.*, 2004). Ohr homologs generally share ~50% sequence identity and contain an invariant cysteine residue corresponding to position 60 in the *X. campestris* sequence and another invariant cysteine within a conserved, VCPY, motif at position 125 along with a conserved arginine (R) residue at position 19 (Lesniak *et al.*, 2002; Cussiol *et al.*, 2003).

Biochemical studies using purified enzyme from several sources confirm that Ohr is a hydroperoxidase with a marked preference for organic peroxides as substrates, although the enzyme is capable of reducing H<sub>2</sub>O<sub>2</sub> with low efficiency *in vitro*. Analyses of wild-type and mutant Ohr indicate that the enzymatic mechanism is analogous to that of the 2 Cys peroxiredoxins. Peroxide reacts with the peroxidatic cysteine at position 60 to form cysteine sulfenic acid (Cys<sub>60</sub>-S-OH) and the corresponding alcohol (R-OH). Cys<sub>60</sub>-OH quickly reacts with the resolving cysteine at position 125 resulting in the formation of an intra-molecular disulfide bond (Lesniak *et al.*, 2002; Cussiol *et al.*, 2003; Oliveira *et al.*, 2006). Therefore, although Ohr is phylogenetically distinct from other peroxiredoxins, its catalytic mechanism is similar to that of an atypical two-Cys peroxiredoxin. The *in vivo* reductant for Ohr has not been identified. *In vitro* Ohr peroxidase requires dithiols, such as DTT, as the reductant. Monothiols do not support peroxidase activity *in vitro* (Lesniak *et al.*, 2002; Oliveira *et al.*, 2006). The finding that the dithiol, dihydrolipoamide, supports Ohr peroxidase activity *in vitro* has led to the suggestion that it may serve as the reductant for Ohr in *Xylella fastidiosa*, as well as in other bacteria (Oliveira *et al.*, 2006).

Crystal structures have been determined for Ohr from *Xylella fastidiosa* (de Oliveira *et al.*, 2004; Oliveira *et al.*, 2006), *Deinococcus radiodurans* (Meunier-Jamin *et al.*, 2004) and *Pseudomonas aeruginosa* (Lesniak *et al.*, 2002). The active form of Ohr is a highly interwoven barrel shaped homo-dimer, in which the individual subunits are oriented head to tail, containing two active sites in equivalent positions at opposite faces of the molecule. The active site is elongated and contains a solvent exposed peroxidatic Cys<sub>60</sub> and a resolving Cys<sub>125</sub> buried within the molecule. In the catalytically active reduced state the active site is covered by an exposed loop that restricts the active site entry to a region rich in hydrophobic residues. The invariant Arg<sub>18</sub> residue within the loop hydrogen bonds with the peroxidatic cysteine thiol and stabilizes it in the more reactive Cys-S<sup>-</sup> ionic



form (Lesniak *et al.*, 2002; Meunier-Jamin *et al.*, 2004; Oliveira *et al.*, 2006). The formation of an intramolecular disulphide bond, upon oxidation by peroxidase, induces a conformational change that shifts the position of the loop to allow wider access to the active site, possibly to facilitate re-reduction of the disulphide by an as yet unidentified molecule (Oliveira *et al.*, 2006). The hydrophobic active site entrance is thought to determine the enzymes preference for organic peroxide substrates, while the elongated narrow shape of the active site has lead to speculation that the *in vivo* substrate for the enzyme may be long chain lipid hydroperoxides (Oliveira *et al.*, 2006; Lesniak *et al.*, 2002; Meunier-Jamin *et al.*, 2004).

#### 4.1.1. *OhrR-Mediated regulation of Ohr*

Most of the *ohr* systems that have been characterized to date are regulated by the peroxide-responsive transcription regulator, OhrR (Sukchawalit *et al.*, 2001; Mongkolsuk and Helmann, 2002; Panmanee *et al.*, 2002; Fuangthong and Helmann, 2002a; Chuchue *et al.*, 2006). OhrR is a member of the MarR family of transcriptional regulators (Wilkinson and Grove, 2006). Members of this family of regulators generally function as repressors by binding to target promoters and blocking RNA polymerase binding or transcript elongation. Repression is relieved through the binding of a signal molecule that reduces the DNA binding affinity of the protein.

A general scheme of OhrR mediated regulation of *ohr* in shown in Fig. 5. Like typical MarR family repressors, OhrR is active as a dimer and represses transcription of target promoters at sites overlapping all or part of the region containing the  $-10$  and  $-35$  promoter elements. In *Xanthomons campestris* and *Agrobacterium tumefaciens*, binding occurs at an AT-rich palindromic sequence (CAATT-N<sub>1-17</sub>-AATTG), known as an “Ohr-Box” (Mongkolsuk and Helmann, 2002; Chuchue *et al.*, 2006), that is also found upstream of *ohrA* in *Bacillus subtilis* (Fuangthong and Helmann, 2002a). OhrR binds to target promoters in its reduced form and blocks RNA polymerase access (Mongkolsuk and Helmann, 2002; Chuchue *et al.*, 2006). Exposure to peroxide renders the protein incapable of binding DNA thus relieving repression. DNA binding can be restored through the reduction of oxidized OhrR with DTT (Panmanee *et al.*, 2002; Fuangthong and Helmann, 2002a; Klomsiri *et al.*, 2005). Unlike other MarR family regulators, Ohr does not bind the effector molecule *per se*, but instead responds to peroxide mediated oxidation of a conserved cysteine residue corresponding to Cys 22 and Cys15 in the *X. campestris* and *B. subtilis* proteins, respectively. This residue is essential for OhrR function and amino acid substitutions at this position result in peroxide insensitive DNA binding and constitutive repression of *ohr* (Panmanee *et al.*, 2002; Fuangthong and Helmann, 2002a; Klomsiri *et al.*, 2005).

There are at least two variations of the OhrR peroxide sensing mechanism that involve either one or two cysteine residues. In *B. subtilis* Cys<sub>15</sub> is the only cysteine involved in peroxide sensing and its oxidation to Cys-sulfenic acid is sufficient to stimulate derepression. In this “one-cysteine” mechanism no disulfide bond formation is observed between monomers (Fuangthong and Helmann, 2002a). In

Mechanism of OhrR mediated repression

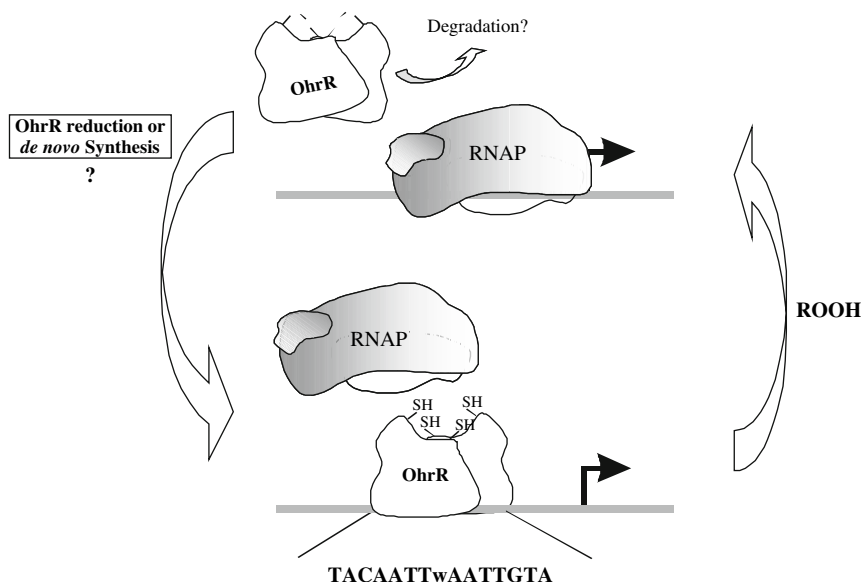

Figure 5. Model of Ohr mediated repression. A model for OhrR mediated transcriptional regulation is shown for a 2-Cys *X. campestris* OhrR. In the absence of oxidative stress OhrR binds to target promoters and block RNA polymerase access. Oxidation of OhrR Cys22 by organic peroxide stimulates the formation of an intersubunit disulfide bond with Cys127. This induces conformational changes that render the protein unable to bind DNA, thus allowing RNA polymerase access to the promoter to initiate transcription. In a single Cys OhrR oxidation of the equivalent of Cys22 to Cys-SOH is sufficient to reverse DNA binding. The fate of oxidized OhrR is not known. It may be re-reduced or subject to degradation followed by *de novo* synthesis of OhrR

*X. campestris*, Cys<sub>127</sub>, the equivalent of *B. subtilis* Cys<sub>15</sub>, is first oxidized to a Cys-sulfenic acid that then participates in a condensation reaction with Cys127 of the opposing monomer to form an intermolecular disulfide bond resulting in the loss of DNA binding activity. The presence of cysteines corresponding to Cys<sub>127</sub> in OhrRs from several other bacteria suggests that the “two-cysteine” mechanism is also found in other systems (Panmanee *et al.*, 2006).

OhrR regulated *ohr* systems have been studied in *Xanthomonas campestris* (Mongkolsuk *et al.*, 1998a; Sukchawalit *et al.*, 2001; Panmanee *et al.*, 2002; Banjerdkiy *et al.*, 2005; Klomsiri *et al.*, 2005), *Bacillus subtilis* (Volker *et al.*, 1998; Fuangthong *et al.*, 2001; Fuangthong and Helmann, 2002a), *Agrobacterium tumefaciens* (Chuchue *et al.*, 2006) and and OhrR possibly regulates *ohr* in *Pseudomonas aeruginosa* as well (Ochsner *et al.*, 2001). Orf maps of the *ohr* encoding loci in each of these organisms are shown in Fig. 4B. In all of these systems *ohr* is closely linked to its *ohrR* regulator and close linkage between *ohr* and *ohrR* has been

observed in many other organisms using genome data base searches (Fuangthong *et al.*, 2001; Sukchawalit *et al.*, 2001; Chuchue *et al.*, 2006).

In *X. campestris*, the *ohrR-ohr* operon is transcribed as a minor 1 kb message encoding *ohrR-ohr* and a major 0.5 kb mRNA encoding *ohr* that both initiate from an OhrR regulated promoter at the A residue of the *ohrR* start codon (Fig. 4B). Therefore, both genes are under OhrR control. OhrR represses transcription of the operon by binding to a region overlapping the putative  $-35$  and  $-10$  promoter elements. Primer extension results mapping the 5' ends of the monocistronic *ohr* mRNA, combined with transcript stability determinations, suggest that an unstable *ohrR-ohr* message is processed at a hairpin loop structure present in the *ohrR-ohr* intergenic region to generate a stable *ohr* mRNA, while the *ohrR*-encoding portion is rapidly degraded (Sukchawalit *et al.*, 2001; Mongkolsuk and Helmann, 2002). It should be noted that Sukchawalit *et al.* (2001) detected the presence of a weak unregulated promoter (P2) activity possibly originating from the *ohrR-ohr* intergenic region using an *ohr*-chloramphenicol acetyltransferase transcriptional fusion construct. However, its presence was not confirmed in subsequent primer extension analyses raising the possibility that the transcriptional fusion data was an artifact.

The *ohrR-ohr* operon in *Pseudomonas aeruginosa* shares the same genomic organization as in *X. campestris* (Fig. 4B). Although the close linkage of the two genes suggests that the operon is likely regulated by OhrR, an analysis by Ochsner *et al.* (2001) indicated that the regulatory mechanism is different from that in *X. campestris*. This is due to the fact that *P. aeruginosa ohr* transcription initiates from a peroxide inducible promoter within the *ohrR-ohr* intergenic region at a point 56 bp upstream of the *ohr* start codon. Promoter mapping studies indicate that an additional 54 bp upstream of the putative  $-35$  promoter element is necessary for regulated promoter activity. No sequences similar to the consensus OhrR-Box are present in this region. No analysis of the OhrR promoter region is yet available, but an acceptable OhrR-box sequence (CAATT-N<sub>12</sub>-AATTG) is present 34 bp upstream of the *ohrR* translation start (Dubbs and Mongkolsuk personal observations).

*Agrobacterium tumefaciens ohr* is divergently transcribed from *ohrR* (Fig. 4B). Under non-inducing conditions, OhrR binding within the *ohrR-ohr* intergenic space, to a region containing an OhrR-Box, represses transcription of both genes. DNaseI foot printing studies have shown that bound OhrR covers the *ohr* promoter  $-10$  and  $-35$  elements, as well as the  $-35$  element of the *ohrR* promoter. Results of gel mobility shift and promoter mapping studies suggest that *ohrR* may bind to the intergenic region in a cooperative fashion with initial binding occurring at the OhrR-Box overlapping the *ohr* promoter (Chuchue *et al.*, 2006).

A final example of an OhrR regulated *ohr* occurs in *B. subtilis*. This organism contains genes encoding two Ohr paralogs, *ohrA* and *ohrB* (Volker *et al.*, 1998; Fuangthong *et al.*, 2001). Both genes are clustered with *ohrR* in the order *ohrA-ohrR-ohrB* (Fig. 4B). OhrR represses *ohrA* transcription in the absence of peroxide by cooperative binding to two Ohr-Boxes overlapping the  $\sigma^A$ -promoter. Unlike previously mentioned examples, OhrR is not autoregulated in this organism nor is

its expression peroxide-inducible (Fuangthong *et al.*, 2001). In spite of the close linkage to *ohrR*, the expression of *ohrB* is *ohr*-independent and will be described in the next section.

In all of the examples described above, *ohr* expression is highly induced in the presence of organic peroxides and shows slight to no induction by H<sub>2</sub>O<sub>2</sub> or the superoxide inducers, (paraquat) and menadione (Mongkolsuk *et al.*, 1998a, Fuangthong *et al.*, 2001, Sukchawalit *et al.*, 2001; Ochsner *et al.*, 2001; Klomsiri *et al.*, 2005; Chuchue *et al.*, 2006). Induction has also been observed in response to exposure to CdCl<sub>2</sub> that is likely to be the result of the Cd<sup>2+</sup>-induced production of organic peroxides (Banjerdikij *et al.*, 2005).

#### 4.1.2. *Ohr* Systems not regulated by *OhrR*

A number of *ohr* homologs have been isolated that are either not under *OhrR* control or their regulator(s) have not been identified. Some of these systems display regulatory patterns that are similar to *OhrR* regulated systems, i.e. peroxide-inducible. Others are regulated in response to more general stress conditions in a manner reminiscent of *E. coli* OsmC. The best characterized of these is *ohrB* in *B. subtilis*. As mentioned earlier, the expression of *ohrB* is not under *OhrR* control, but is regulated by the stress sigma factor  $\sigma^B$  (Volker *et al.*, 1998). Transcription of *ohrB* is driven from a single  $\sigma^B$ -dependent promoter that gives rise to a monocistronic 0.5 kb *ohrB* mRNA during normal growth. Two additional messages of 0.8 kb and 1.4 kb appear during growth under stress conditions (Fig. 4B). The expression of *ohrB* is induced in response to starvation, as well as exposure to high salt, ethanol or heat (Volker *et al.*, 1998; Fuangthong *et al.*, 2001).

A similar pattern of expression is also seen for an *ohr* (*gsp65*) isolated from *Enterococcus faecalis* (Rince *et al.*, 2001) (Fig. 4B). Expression of this *ohr* is highly induced by the organic peroxide, *t*BOOH, but is also upregulated in response to general stresses such as exposure to acid pH, heat, high salt, bile salts, SDS, ethanol and only slightly by H<sub>2</sub>O<sub>2</sub>. Transcription is driven by a  $\sigma^{70}$ -like promoter that is near several direct and inverted repeat sequences that could serve as binding sites for, as yet, unidentified regulators.

Two final examples of organic peroxide-inducible *ohr* systems occur in the porcine pathogen, *Actinobacillus pleuropneumoniae* and the nitrogen-fixing plant symbiont, *Rhizobium etli* (Fig. 4B). In *A. pleuropneumoniae*, Shea and Mulks (2002) isolated *ohr* during a screen for genes that were expressed during infection of the pig lung. Promoter fusion experiments using a *lux* reporter construct demonstrated that this *ohr* was expressed at a low constitutive level during growth in culture and that expression was induced in the presence of the organic peroxide cumene hydroperoxide (CuOOH), but not H<sub>2</sub>O<sub>2</sub> or the superoxide inducer paraquat. Induction was also detected *in situ* during active lung infection suggesting a role in defense against host-generated peroxides. Transcription initiated from a point 31 bps upstream of the *ohr* start codon. A sequence resembling an *Actinobacillus* "Housekeeping" -10 promoter element was found 6 bp upstream of the transcription start, while an *E. coli*-like SoxS consensus binding sequence was present in place

of a  $-35$  promoter element. Also, no sequences resembling an Ohr-Box were found in the promoter region and blast searches of the *Actinobacillus* partial genome sequence failed to detect any close homologs of *ohrR* (Dubbs and Mongkolsuk, personal observations).

Genetic linkage of *ohr* to a seemingly unrelated metabolic gene occurs in the plant symbiont *R. etli*. Tellez-Sosa *et al.* (2002) isolated an operon containing an adenylate cyclase encoding gene (*cyaC*) that is co-transcribed with an upstream *ohr*. Expression of the operon was induced by cumene hydroperoxide but not  $H_2O_2$ , heat or high NaCl concentrations. Inactivation of the operon had no effect on growth, organic peroxide sensitivity or the ability to colonize plant roots. This may be due to the fact that the genome of this organism encodes at least 5 *ohr* homologs.

#### 4.1.3. Physiological role of Ohr

Consistent with the enzyme's preference for organic peroxides *in vitro*, inactivation of *ohr* leads to organic peroxide sensitivity (Mongkolsuk *et al.*, 1998a; Fuangthong *et al.*, 2001; Ochsner *et al.*, 2001; Rince *et al.*, 2001; Vattanaviboon *et al.*, 2002; Klomsiri *et al.*, 2005; Chuchue *et al.*, 2006) and a significant reduction in the ability of cells, or cell extracts, to detoxify organic peroxides (Fuangthong *et al.*, 2001; Ochsner *et al.*, 2001; Vattanaviboon *et al.*, 2002; Klomsiri *et al.*, 2005; Chuchue *et al.*, 2006) in the majority of cases. The mutant phenotypes, combined with the fact that: 1) *ohr* is often specifically induced by organic peroxides and 2) that the repressor, OhrR, preferentially senses organic peroxides (Panmanee *et al.*, 2002; Klomsiri *et al.*, 2005), indicates that *ohr* is involved in organic peroxide defense. No role for *ohr* in  $H_2O_2$  defense is indicated, since *ohr* inactivation generally does not affect the  $H_2O_2$  resistance level and no compensatory increases in catalase are observed (Mongkolsuk *et al.*, 1998a).

The *in vivo* organic peroxide substrates for *ohr* are unknown, but are thought to include lipid peroxides based primarily on the enzyme's active site architecture and the observation that in *X. campestris* linoleic acid hydroperoxide (LOOH) is a more effective inducer of *ohr* expression than *tert*-butyl hydroperoxide (*t*BOOH) or cumene hydroperoxide (CuOOH) (Klomsiri *et al.*, 2005). One study suggests that *ohr* plays a role in organic peroxide defense during infection. Shea and Mulks (2002) observed that an *Actinobacillus pleuropneumoniae* strain carrying an *ohr*-promoter: *lux* fusion construct was expressed in porcine lungs at sites of infection. A potential role for *ohr* in virulence is also suggested by the fact that an *ohr-ohrR* operon is maintained on a mobilizable plasmid of the opportunistic human pathogen *Acinetobacter baumannii* (Dorsey *et al.*, 2006).

## 4.2. Osmotically Inducible Protein: OsmC

### 4.2.1. Structure and biochemistry of OsmC

*osmC* was initially identified in *E. coli* as a gene that was induced in response to high osmolarity (Gutierrez *et al.*, 1987). *E. coli*, *osmC* encodes a protein of 138 amino acids with a predicted molecular weight of  $\sim 14.5$  kDa (Gutierrez and Devedjian,

1991). The amino acid sequences of members of the OsmC subfamily are similar to those of the Ohr subfamily with amino acid sequence identities in the general range of 20% to 30%. OsmC subfamily members share the conserved peroxidatic and resolving cysteines corresponding to positions 59 and 129 in the *E. coli* sequence (Atichartpongkul *et al.*, 2001; Lesniak *et al.*, 2003; Shin *et al.*, 2004). Bacterial OsmC does not appear to be as widely distributed as Ohr (Atichartpongkul *et al.*, 2001).

*osmC* has been studied extensively as a model system for examining osmotic regulation in *E. coli*. Its possible function remained a mystery until its similarity to Ohr was noted (Mongkolsuk *et al.*, 1998a; Atichartpongkul *et al.*, 2001), leading to the demonstration by Lesniak *et al.* (2003) that OsmC was indeed a peroxidase. Biochemical studies performed using *E. coli* OsmC (Lesniak *et al.*, 2003), as well as the enzyme isolated from *Thermus thermophilus* (Rehse *et al.*, 2004), showed that OsmC is similar to Ohr in that it is able to utilize both H<sub>2</sub>O<sub>2</sub> and organic hydroperoxides (*t*-butyl hydroperoxide and cumene hydroperoxide) as substrates, but shows a strong preference for organic peroxides.

Based on the crystal structures for the *E. coli* (Lesniak *et al.*, 2003; Shin *et al.*, 2004) and *T. thermophilus* (Rehse *et al.*, 2004) enzymes, OsmC tertiary structure is very similar to that of Ohr (i.e. a barrel shaped homo-dimer of interwoven subunits in a head to tail arrangement with active sites at opposite ends of the molecule containing the equivalents to the conserved peroxidatic Cys<sub>60</sub> and the resolving Cys<sub>125</sub> of Ohr). Some of the structural differences between OsmC and Ohr are found in the active site. Like Ohr, the peroxidatic cysteine of OsmC is stabilized in a more reactive Cys-S<sup>-</sup> form by hydrogen bonding to an arginine at position 39 instead of at position 18 in Ohr. Unlike Ohr, the peroxidatic cysteine of OsmC is buried within the molecule while the resolving cysteine is solvent exposed. The general shapes of the active sites also differ. The OsmC active site is wider and shallower than the elongated and narrow active site of OhrR. Finally, while the active site entrances in both OsmC and Ohr are lined with hydrophobic residues, OsmC contains more aromatic residues (Shin *et al.*, 2004). All of these active site differences have led to speculation that the preferred *in vivo* substrates of the two enzymes differ (Lesniak *et al.*, 2003; Rehse *et al.*, 2004; Shin *et al.*, 2004).

#### 4.2.2. Regulation of *OsmC*

The regulation of *E. coli osmC* has been studied in some detail and is quite complex (Fig. 6). In this organism *osmC* is transcribed from two closely spaced promoters initiating at points 19 (P2) and 29 bp (P1) upstream of the *osmC* translation start (Gutierrez and Devedjian, 1991). The P1 sequence contains  $\sigma^{70}$  -10 and -35 sequence elements, while P2 contains a good -10 sequence element but no -35 element (Gordia and Gutierrez, 1996). Transcription of *osmC* is regulated in response to growth phase, exposure to acetate and increased osmolarity, as well as exposure to the membrane stress-inducing molecule, chlorpromazine (Gutierrez *et al.*, 1987; Gutierrez and Devedjian, 1991; Gordia and Gutierrez, 1996; Arnold *et al.*, 2001; Conter *et al.*, 2002). This is accomplished through

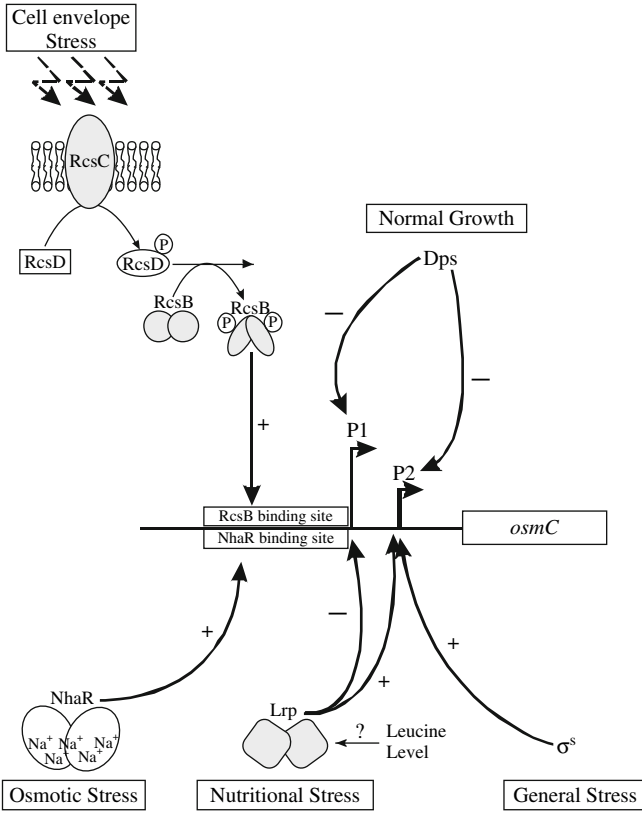

Figure 6. Regulation of *osmC* in *E. coli*. The known regulators of *osmC* transcription; NhaR, RcsCDB, Lrp,  $\sigma^s$  and Dps are shown, along with their regulatory effect (+/-) on the *osmC* P1 and P2 promoters as described in the text. The relative positions of overlapping NhaR and RcsB binding sites upstream of *osmC* P1 are shown

the independent regulation of the P1 and P2 promoters via the action of multiple regulators.

Promoter-*lacZ* fusion studies by Gordia and Gutierrez (1996) determined that during growth of *E. coli* in low salt media, *osmC* is expressed at a low basal level. Expression is induced at the onset of stationary phase and halts in late stationary phase. Addition of salt to the media results in an earlier onset of *osmC* induction in late exponential phase that trails off as the cells enter stationary phase, as well as in an increase in the overall level of induction. Both P1 and P2 were found to display growth phase-dependent regulation with P1 induction occurring in mid-log phase while the much stronger (10-fold) P2 promoter was induced in stationary phase. Both promoters were induced at higher levels in high salt. Expression from P2 was found to be dependent on the stationary phase sigma factor  $\sigma^s$ , while P1 expression was  $\sigma^s$ -independent.

Further work looking at the regulation of the  $\sigma^{70}$ -dependent P2 promoter indicate that it is positively regulated in response to increased osmolarity and membrane stress by the solute-responsive activator, NhaR and the RcsC-RcsD-RcsB two-component regulatory system, respectively. NhaR is a LysR-family activator that is known to regulate *nhaA*, encoding a Na<sup>+</sup>/H<sup>+</sup> antiporter, in response to increased Na<sup>+</sup> and Li<sup>+</sup> concentrations (Rahav-Manor *et al.*, 1992). Evidence for NhaR involvement in *osmC* regulation comes from the observations that inactivation of NhaR reduces solute-stimulated induction of *osmC*, while over-expression of *NhaR* stimulates induction. Furthermore, NhaR, in crude extracts of NhaR over-expressing *E. coli* strains, binds within 16 bp upstream of the P1 promoter -35 element, as determined using gel mobility shift and DNase I protection assays (Toesca *et al.*, 2001).

The RcsC-RcsD-RcsB two component regulatory system is also a positive regulator of *osmC* P1. RcsC-RcsD-RcsB constitutes a phosphorelay system consisting of the sensor kinase, RcsC, the intermediate phosphotransfer protein, RcsD, and the DNA binding response regulator, RcsB. The specific environmental signal(s) sensed by the system are not known; however, the RcsC-RcsD-RcsB system is generally activated in response to perturbations of the cell envelope (Majdalani and Gottesman, 2005). In regard to *osmC* regulation, over-expression of RcsB from a plasmid activated an *osmC* P1-*lacZ* fusion construct, while inactivation of *rscB* reduced *osmC* P1 activity. Purified RcsB also enhanced transcription from *osmC* P1 in an *in vitro* transcription assay. Gel mobility shift studies showed that *RcsB* increased the affinity of RNA polymerase binding to the *osmC* P1 promoter indicating that RcsB is likely to physically interact with RNA polymerase (Davalos-Garcia *et al.*, 2001). No binding to the *osmC* P1 promoter region could be detected using purified wild type RcsB. However, DNaseI foot printing experiments using a mutant RcsB, that displayed enhanced DNA binding properties, allowed the identification of an RcsB binding site immediately upstream of the *osmC* P1 -35 element that overlapped the NhaR binding site. Studies looking at the effect of the over-expression of RcsB and NhaR on *osmC* P1 promoter activity in *rscB* and *nhaR* mutants indicate that both proteins exert their regulatory effect independent of one another. However, the level of *osmC* P1 induction in an RcsB over-expressing strain was much higher in an *nhaR* mutant than in the wild type, indicating that competition for binding at *osmC* P1 may occur (Sturny *et al.*, 2003).

Two additional global regulatory systems are also known to be involved in *osmC* regulation. The first of these is the leucine responsive regulator, Lrp. Lrp is a global regulator that senses the nutritional state of the cell by monitoring the level of free amino acids. It does this by responding to the cellular levels of leucine (Newman and Lin, 1995). Lrp has been shown to bind to the *osmC* promoter region in gel mobility shift assays and a putative Lrp consensus DNA binding motif is present 13 bp upstream of the *osmC* P1 promoter -35 element (Bouvier *et al.*, 1998). Inactivation of *lrp* causes an increase in the activity of *osmC* P1 promoter, suggesting that *lrp* is a negative regulator of *osmC* P1. *lrp* inactivation causes the growth phase-dependent induction of *osmC* to occur earlier (i.e. in mid-exponential



phase) and to continue throughout stationary phase. This change in the regulatory pattern is due to an increase in the  $\sigma^s$  level resulting from *lrp* inactivation. However, the level of *osmC* P2 activity was much lower than that in a wild type background indicating that *lrp* was also a positive effector of *osmC* P2 (Bouvier *et al.*, 1998).

H-NS is a global transcriptional regulator that is involved in managing large-scale shifts in gene regulation in response to a variety of stresses and other environmental changes (Dorman, 2004). H-NS most often functions as a transcriptional repressor and binds to promoters at regions of curved DNA, as opposed to a specific binding sequence. H-NS negatively regulates both the *osmC* P1 and P2 promoters, since the activity of both promoters is significantly higher in an *hns* mutant background (Gutierrez and Devedjian, 1991; Bouvier *et al.*, 1998). The affect of *hns* inactivation on P2 expression appears to be, at least in part, the result of increased expression of RpoS. Increased expression of P1 in an *hns* mutant may also be an indirect effect, since purified H-NS did not bind the P1 promoter region in gel mobility shift assays (Bouvier *et al.*, 1998).

#### 4.2.3. Physiological role of OsmC

Results of the analysis of an *E. coli osmC* mutant indicate that OsmC functions in oxidative stress defense. A study by Conter *et al.* (2001) showed that inactivation of *osmC* led to slight increases in sensitivity to H<sub>2</sub>O<sub>2</sub>, cumene hydroperoxide and a much greater increase in sensitivity to *tert*-butyl hydroperoxide. This effect was seen in both exponential and stationary phase. No effect on sensitivity to oxidative stress inducers such as: superoxide generators (paraquat and menadione), CdCl<sub>2</sub>, ethanol and the disulphide stress inducer N-ethylmaleimide was observed.

Although earlier work found that *osmC* was not essential for growth (Gutierrez and Devedjian, 1991), a study by Conter *et al.* (2001) demonstrated that an *osmC* mutant displayed reduced viability in late stationary phase. The extent of viability loss was dependent on the level of aeration implicating oxidative stress as the cause of lethality. Thus, the *osmC* expression pattern combined with the mutant phenotype suggest that the physiological role of OsmC is detoxify peroxides (probably organic peroxides) resulting from nutritional stress during stationary phase, as well as other types of general stress such as increased osmolarity or perturbations of the cell envelope.

## 5. CONCLUSION

Our current limited knowledge concerning the physiological role of peroxiredoxins combined with their wide distribution in bacteria clearly indicates the important role these interesting enzymes play in peroxide defense. It also illustrates their importance in host colonization and in resistance to more general environmental stresses. Additional work is needed to characterize the regulatory mechanisms controlling individual peroxiredoxin systems, as well as to identify their physiological substrates and reductants. Increased knowledge of how peroxiredoxins are integrated into the

overall bacterial stress response will further our understanding of how bacteria adjust their physiology to cope with shifts in environmental conditions.

## ACKNOWLEDGEMENTS

The authors thank Piyapol Munpiyakit for help in the preparation of figures. Research in the laboratory of S. Mongkolsuk is supported by a Research Team Strengthening Grant from the BIOTEC, a Senior Research Scholar Grant RTA4580010 from the Thailand Research Fund and by a grant from the ESTM through the Higher Education Development Project of the Ministry of University Affairs.

## REFERENCES

- Ades, S.E., 2004, Control of the alternative sigma factor sigmaE in *Escherichia coli*. *Curr. Opin. Microbiol.* **7**: 157–162.
- Antelmann, H., Engelmann, S., Schmid, R., and Hecker, M., 1996, General and oxidative stress responses in *Bacillus subtilis*: cloning, expression, and mutation of the alkyl hydroperoxide reductase operon. *J. Bacteriol.* **178**: 6571–6578.
- Armstrong-Buisseret, L., Cole, M.B., and Stewart, G.S., 1995, A homologue to the *Escherichia coli* alkyl hydroperoxide reductase AhpC is induced by osmotic upshock in *Staphylococcus aureus*. *Microbiol.* **141**: 1655–1661.
- Arnold, C.N., McElhanon, J., Lee, A., Leonhart, R., and Siegele, D.A., 2001, Global analysis of *Escherichia coli* gene expression during the acetate-induced acid tolerance response. *J. Bacteriol.* **183**: 2178–2186.
- Atichartpongkul, S., Loprasert, S., Vattanaviboon, P., Whangsuk, W., Helmann John, D., and Mongkolsuk, S., 2001, Bacterial Ohr and OsmC paralogues define two protein families with distinct functions and patterns of expression. *Microbiol.* **147**: 1775–1782.
- Baillon, M.-L.A., van Vliet, A.H.M., Ketley, J.M., Constantinidou, C., and Penn, C.W., 1999, An iron-regulated alkyl hydroperoxide reductase (AhpC) confers aerotolerance and oxidative stress resistance to the microaerophilic pathogen *Campylobacter jejuni*. *J. Bacteriol.* **181**: 4798–4804.
- Baker, L.M., and Poole, L.B., 2003, Catalytic mechanism of thiol peroxidase from *Escherichia coli*. Sulfenic acid formation and overoxidation of essential CYS61. *J. Biol. Chem.* **278**: 9203–9211.
- Baker, L.M., Raudonikiene, A., Hoffman, P.S., and Poole, L.B., 2001, Essential thioredoxin-dependent peroxiredoxin system from *Helicobacter pylori*: genetic and kinetic characterization. *J. Bacteriol.* **183**: 1961–1973.
- Banjerdkij, P., Vattanaviboon, P., and Mongkolsuk, S., 2005, Exposure to cadmium elevates expression of genes in the OxyR and OhrR regulons and induces cross-resistance to peroxide killing treatments in *Xanthomonas campestris*. *Appl. Environ. Microbiol.* **7**: 1843–1849.
- Bernhardt, J., Volker, U., Volker, A., Antelmann, H., Schmid, R., Mach, H., and Hecker, M., 1997, Specific and general stress proteins in *Bacillus subtilis* - a two-dimensional protein electrophoresis study. *Microbiol.* **143**: 999–1017.
- Blankenhorn, D., Phillips, J., and Slonczewski, J.L., 1999, Acid- and base-induced proteins during aerobic and anaerobic growth of *Escherichia coli* revealed by two-dimensional gel electrophoresis. *J. Bacteriol.* **181**: 2209–2216.
- Bouvier, J., Gordia, S., Kampmann, G., Lange, R., Hengge-Aronis, R., and Gutierrez, C., 1998, Interplay between global regulators of *Escherichia coli*: effect of RpoS, Lrp and H-NS on transcription of the gene *osmC*. *Mol. Microbiol.* **28**: 971–980.
- Brenot, A., King, K.Y., and Caparon, M.G., 2005, The PerR regulon in peroxide resistance and virulence of *Streptococcus pyogenes*. *Mol. Microbiol.* **55**: 221–234.

- Brune, I., Brinkrolf, K., Kalinowski, J., Puhler, A., and Tauch, A., 2005, The individual and common repertoire of DNA-binding transcriptional regulators of *Corynebacterium glutamicum*, *Corynebacterium efficiens*, *Corynebacterium diphtheriae* and *Corynebacterium jeikeium* deduced from the complete genome sequences. *BMC Genomics* **6**: 86.
- Bryk, R., Griffin, P., and Nathan, C., 2000, Peroxynitrite reductase activity of bacterial peroxiredoxins. *Nature* **407**: 211–215.
- Bryk, R., Lima, C.D., Erdjument-Bromage, H., Tempst, P., and Nathan, C., 2002, Metabolic enzymes of mycobacteria linked to antioxidant defense by a thioredoxin-like protein. *Science* **295**: 1073–1077.
- Bsat, N., Chen, L., and Helmann, J.D., 1996, Mutation of the *Bacillus subtilis* alkyl hydroperoxide reductase (*ahpCF*) operon reveals compensatory interactions among hydrogen peroxide stress genes. *J. Bacteriol.* **178**: 6579–6586.
- Bsat, N., Herbig, A.F., Cassillas-Martinez, L., Setlow, P., and Helmann, J.D., 1998, *Bacillus subtilis* contains multiple Fur homologues: identification of the iron uptake (Fur) and peroxide regulon (PerR) repressors. *Mol. Microbiol.* **29**: 189–198.
- Cha, M.-K., Kim, H.-K., and Kim, I.-H., 1995, Thioredoxin-linked “thiol peroxidase” from periplasmic space of *Escherichia coli*. *J. Biol. Chem.* **270**: 28635–28641.
- Cha, M.-K., Kim, H.-K., and Kim, I.-H., 1996, Mutation and Mutagenesis of thiol peroxidase of *Escherichia coli* and a new type of thiol peroxidase family. *J. Bacteriol.* **178**: 5610–5614.
- Cha, M.-K., Kim, W.-C., Lim, C.-J., Kim, K., and Kim, I.-H., 2004, *Escherichia coli* periplasmic thiol peroxidase acts as lipid hydroperoxide peroxidase and the principal antioxidative function during anaerobic growth. *J. Biol. Chem.* **279**: 8769–8778.
- Chae, H.Z., Robison, K., Poole, L.B., Church, G., Storz, G., and Rhee, S.G., 1994, Cloning and sequencing of thiol-specific antioxidant from mammalian brain: alkyl hydroperoxide reductase and thiol-specific antioxidant define a large family of antioxidant enzymes. *Proc Natl Acad. Sci. USA* **91**: 7017–7021.
- Charoenlap, N., Eiamphungporn, W., Nopmanee, C., Utamapongchai, S., Vattanaviboon, P., and Mongkolsuk, S., 2005, OxyR mediated compensatory expression between *ahpC* and *katA* and the significance of *ahpC* in protection from hydrogen peroxide in *Xanthomonas campestris*. *FEMS Microbiol. Lett* **249**: 73–78.
- Chen, L., Keramati, L., and Helmann, J.D., 1995, Coordinate regulation of *Bacillus subtilis* peroxide stress genes by hydrogen peroxide and metal ions. *Proc. Natl. Acad. Sci. USA* **92**: 8190–8194.
- Chen, L., Xie, Q.-W., and Nathan, C., 1998, Alkyl hydroperoxide reductase subunit C (AhpC) protects bacterial and human cells against reactive nitrogen intermediates. *Mol. Cell.* **1**: 795–805.
- Choi, J., Choi, S., Choi, J., Cha, M.-K., Kim, I.-H., and Shin, W., 2003, Crystal structure of *Escherichia coli* thiol peroxidase in the oxidized state: insights into intramolecular disulfide formation and substrate binding in atypical 2-Cys peroxiredoxins. *J. Biol. Chem.* **278**: 49478–49486.
- Christman, M.F., Morgan, R.W., Jacobson, F.S., and Ames, B.M., 1985, Positive control of a regulon for defenses against oxidative stress and some heat-shock proteins in *Salmonella typhimurium*. *Cell* **41**: 753–762.
- Chuang, M.-H., Wu, M.-S., Lo, W.-L., Jaw-Town, L., Wong, C.-H., and Chiou, S.-H., 2006, The antioxidant protein alkylhydroperoxide reductase of *Helicobacter pylori* switches from a peroxide reductase to a molecular chaperone function. *Proc. Natl. Acad. Sci. USA* **103**: 2552–2557.
- Chuchue, T., Tanboon, W., Prapagee, B., Dubbs, J.M., Vattanaviboon, P., and Mongkolsuk, S., 2006, *ohrR* and *ohr* are the primary sensor/regulator and protective genes against organic hydroperoxide stress in *Agrobacterium tumefaciens*. *J. Bacteriol.* **188**: 842–851.
- Comtois, S.L., Gidley, M.D., and Kelly, D.J., 2003, Role of the thioredoxin system and the thiol-peroxidases Tpx and Bcp in mediating resistance to oxidative and nitrosative stress in *Helicobacter pylori*. *Microbiol.* **149**: 121–129.
- Conter, A., Gagneaux, C., Magali, S., and Gutierrez, C., 2001, Survival of *Escherichia coli* during long-term starvation: effects of aeration, NaCl, and the *rpoS* and *osmC* gene products. *Res. Microbiol.* **152**: 17–26.
- Conter, A., Sturny, R., Gutierrez, C., and Cam, K., 2002, The RcsCB His-Asp phosphorelay system is essential to overcome chlorpromazine-induced stress in *Escherichia coli*. *J. Bacteriol.* **10**: 2850–2853.

- Cussioli, J.R.R., Alves, S.V., de Oliveira, M.A., and Netto, L.E.S., 2003, Organic hydroperoxide resistance gene encodes a thiol-dependent peroxidase. *J. Biol. Chem.* **278**: 11570–11578.
- Davalos-Garcia, M., Conter, A., Toesca, I., Gutierrez, C., and Cam, K., 2001, Regulation of *osmC* gene expression by the two-component system *rcsB-rcsC* in *Escherichia coli*. *J. Bacteriol.* **183**: 5870–5876.
- de Oliveira, M.A., Netto, L.E.S., Medrano, F.J., Barbosa, G., Alves, S.V., Cussioli, J.R.R., and Guimares, B.G., 2004, Crystallization and preliminary X-ray diffraction analysis of an oxidized state of Ohr from *Xylella fastidiosa*. *Acta Crystallogr. D Biol. Crystallogr.* **60**: 337–339.
- Deretic, V., Philipp, W., Dhandayuthapani, S., Mudd, M.H., Curcic, R., Garbe, T.R., Heym, B., Via, L.E., and Cole, S.T., 1995, *Mycobacterium tuberculosis* is a natural mutant with an inactivated oxidative-stress regulatory gene: implications for sensitivity to isoniazid. *Mol. Microbiol.* **17**: 889–900.
- Dhandayuthapani, S., Mudd, M.H., and Deretic, V., 1997, Interactions of OxyR with the promoter region of the *oxyR* and *ahpC* genes from *Mycobacterium leprae* and *Mycobacterium tuberculosis*. *J. Bacteriol.* **179**: 2401–2409.
- Dhandayuthapani, S., Zhang, Y., Mudd, M.H., and Deretic, V., 1996, Oxidative stress response and its role in sensitivity to isoniazid in mycobacteria: characterization and inducibility of *ahpC* by peroxides in *Mycobacterium smegmatis* and lack of expression in *M. aurum* and *M. tuberculosis*. *J. Bacteriol.* **178**: 3641–3649.
- Diaz, P.I., V, W., Corthals, G.L., and Rogers, A.H., 2004, Studies on NADH oxidase and alkyl hydroperoxide reductase produced by *Porphyromonas gingivalis*. *Oral Microbiol. Immunol.* **19**: 137–143.
- Dintilhac, A., and Claverys, J.P., 1997, The *adc* locus, which affects competence for genetic transformation in *Streptococcus pneumoniae*, encodes an ABC transporter with a putative lipoprotein homologous to a family of streptococcal adhesins. *Res. Microbiol.* **148**: 119–131.
- Dolin, M.I., 1961, Cytochrome-independent electron transport enzymes of bacteria, in *The bacteria* Vol. 2 (Gunsalus, I.C. and Stanier, R.Y., eds), Academic Press Inc., New York, N.Y., USA, pp. 425–460.
- Domenech, P., Honore, N., Heym, B., and Cole, S.T., 2001, Role of OxyS of *Mycobacterium tuberculosis* in oxidative stress: overexpression confers increased sensitivity to organic hydroperoxides. *Microbes. Infect.* **3**: 713–721.
- Dorman, C.J., 2004, H-NS: a universal regulator for a dynamic genome. *Nat Rev Microbiol* **2**: 391–400.
- Dorsey, C.W., Tomaras, A.P., and Actis, L.A., 2006, Sequence and organization of pMAC, an *Acinetobacter baumannii* plasmid harboring genes involved in organic peroxide resistance. *Plasmid* **56**: 112–123.
- Dosanjh, N.S., Rawat, M., Chung, J.-H., and Av-Gay, Y., 2005, Thiol specific oxidative stress response in *Mycobacteria*. *FEMS Microbiol. Lett.* **249**: 87–94.
- Ellis, H.R., and Poole, L.B., 1997, Roles for the two cysteine residues of AhpC in catalysis of peroxide reduction by alkyl hydroperoxide reductase from *Salmonella typhimurium*. *Biochemistry* **36**: 13349–13356.
- Elsaghier, A., Nolan, A., Allen, B., and Ivanyi, J., 1992, Distinctive western blot antibody patterns induced by infection of mice with individual strains of the *Mycobacterium avium* complex. *Immunol.* **76**: 355–361.
- Ernst, F.D., Bereswill, S., Waidner, B., Stoeff, J., Mader, U., Kusters, J.G., Kuipers, E.J., Kist, M., van Vliet, A.H.M., and Homuth, G., 2005a, Transcriptional profiling of *Helicobacter pylori* Fur- and iron-regulated gene expression. *Microbiol.* **151**: 533–546.
- Ernst, F.D., Homuth, G., Stoeff, J., Mader, U., Waidner, B., Kuipers, E.J., Kist, M., Kusters, J.G., Bereswill, S., and van Vliet, A.H.M., 2005b, Iron-responsive regulation of the *Helicobacter pylori* iron-cofactored superoxide dismutase SodB is mediated by Fur. *J. Bacteriol.* **187**: 3687–3692.
- Francis, K.P., and Gallagher, M.P., 1993, Light emission from a *MudIux* transcriptional fusion in *Salmonella typhimurium* is stimulated by hydrogen peroxide and by interaction with the mouse macrophage cell line J774.2. *Infect. Immun.* **61**: 640–649.
- Francis, K.P., Taylor, P.D., Inchley, C.J., and Gallagher, M.P., 1997, Identification of the *ahp* operon of *Salmonella typhimurium* as a macrophage-induced locus. *J. Bacteriol.* **179**: 4046–4048.
- Fuangthong, M., Atichartpongkum, S., Mongkolsuk, S., and Helmann, D., 2001, OhrR is a repressor of *ohrA*, a key organic hydroperoxide resistance determinant in *Bacillus subtilis*. *J. Bacteriol.* **183**: 4134–4141.

- Fuangthong, M., and Helmann, J.D., 2003, Recognition of DNA by three ferric uptake regulator (Fur) homologs in *Bacillus subtilis*. *J. Bacteriol.* **185**: 6348–6357.
- Fuangthong, M., and Helmann, D., 2002a, The OhrR repressor senses organic hydroperoxides by reversible formation of a cysteine-sulfenic acid derivative. *Proc. Natl. Acad. Sci. USA* **99**: 6690–6695.
- Fuangthong, M., Herbig, A.F., Bsat, N., and Helmann, D., 2002b, Regulation of the *Bacillus subtilis* fur and perR genes by PerR: not all members of the PerR regulon are peroxide inducible. *J. Bacteriol.* **184**: 3276–3286.
- Fukumori, F., and Kishii, M., 2001, Molecular cloning and transcriptional analysis of the alkyl hydroperoxide reductase genes from *Pseudomonas putida* KT2442. *J. Gen. Appl. Microbiol.* **47**: 269–277.
- Gancz, H., Censini, S., and Merrell, D.S., 2006, Iron and pH homeostasis intersect at the level of Fur regulation in the gastric pathogen *Helicobacter pylori*. *Infect. Immun.* **74**: 602–614.
- Ganeshkumar, N., Hannam, P.M., Kolenbrander, P.E., and McBride, B.C., 1991, Nucleotide sequence of a gene coding for a saliva-binding protein (SsaB) from *Streptococcus sanguis* 12 and possible role of the protein in coaggregation with actinomycetes. *Infect. Immun.* **59**: 1093–1099.
- Garbe, T.R., Kobayashi, M., and Yukawa, H., 2000, Indole-inducible proteins in bacteria suggest membrane and oxidant toxicity. *Arch. Microbiol.* **173**: 78–82.
- Gordia, S., and Gutierrez, C., 1996, Growth-phase-dependent expression of the osmotically inducible gene *osmC* of *Escherichia coli* K-12. *Mol. Microbiol.* **19**: 729–736.
- Greenberg, J.T., and Demple, B., 1988, Overproduction of peroxide-scavenging enzymes in *Escherichia coli* suppresses spontaneous mutagenesis and sensitivity to redox-cycling agents in *oxyR*-mutants. *EMBO J.* **7**: 2611–2617.
- Gutierrez, C., Barondess, J., Manoil, C., and Beckwith, J., 1987, The use of transposon *TnphoA* to detect genes for cell envelope proteins subject to a common regulatory stimulus. Analysis of osmotically regulated genes in *Escherichia coli*. *J. Mol. Biol.* **195**: 289–297.
- Gutierrez, C., and Devedjian, J.C., 1991, Osmotic induction of gene *osmC* expression in *Escherichia coli* K12. *J. Mol. Biol.* **220**: 959–973.
- Hahn, J.-S., Oh, S.-Y., and Roe, J.-H., 2002, Role of OxyR as a peroxide-sensing positive regulator in *Streptomyces coelicolor* A3(2). *J. Bacteriol.* **184**: 5214–5222.
- Halliwell, B., and Gutteridge, J.M.C., 1984, Oxygen toxicity, oxygen radicals, transition metals and disease. *Biochem. J.* **219**: 1–14.
- Hausladen, A., Privalle, C.T., Keng, T., De Angelo, J., and Stamler, J.S., 1996, Nitrosative stress: activation of the transcription factor OxyR. *Cell* **86**: 719–729.
- Hecker, M., and Volker, A., 2001, General stress response of *Bacillus subtilis* and other bacteria. *Adv. Microb. Physiol.* **44**: 35–91.
- Helmann, J.D. (2002). OxyR: A molecular code for redox sensing. *Sci STKE* **157**: PE46.
- Helmann, J.D., Wu, M., Fang, Winston, Gaballa, A., Kobel, P.A., Morshedi, M.M., Fawcett, P., and Paddon, C., 2003, The global transcriptional response of *Bacillus subtilis* to peroxide stress is coordinated by three transcription factors. *J. Bacteriol.* **185**: 243–253.
- Henikoff, S., Haughn, G.W., Calvo, J.M., and Wallace, J.C., 1988, A large family of bacterial activator proteins. *Proc. Natl. Acad. Sci. USA* **85**: 6602–6606.
- Herbig, A.F., and Helmann, J.D., 2001, Roles of metal ions and hydrogen peroxide in modulating the interaction of the *Bacillus subtilis* PerR peroxide regulon repressor with operator DNA. *Mol. Microbiol.* **41**: 849–859.
- Higuchi, M., Yamamoto, Y., and Kamio, Y., 2000, Molecular biology of oxygen tolerance in lactic acid bacteria: Functions of NADH oxidases and Dpr in oxidative stress. *J. Biosci. Bioeng.* **90**: 484–493.
- Higuchi, M., Yamamoto, Y., Poole, L.B., Shimada, M., Satoh, Y., Takahashi, N., and Kamio, Y., 1999, Functions of two types of NADH oxidases in energy metabolism and oxidative stress of *Streptococcus mutans*. *J. Bacteriol.* **181**: 5940–5947.
- Hillas, P.J., Soto del Alba, F., Oyarzabal, J., Wilks, A., and Ortiz de Montellano, P.R., 2000, The AhpC and AhpD antioxidant defense system of *Mycobacterium tuberculosis*. *J. Biol. Chem.* **275**: 18801–18809.
- Hoper, D., Bernhardt, J., and Hecker, M., 2006, Salt stress adaptation of *Bacillus subtilis*: a physiological proteomics approach. *Proteomics* **6**: 1550–62.

- Horsburgh, M.J., Clements, M.O., Crossley, H., Ingham, E., and Foster, S.J., 2001, PerR controls oxidative stress resistance and iron storage proteins and is required for virulence in *Staphylococcus aureus*. *Infect. Immun.* **69**: 3744–3754.
- Imlay, J.A., 2003, Pathways of oxidative damage. *Annu. Rev. Microbiol.* **57**: 395–418.
- Jacobson, F.S., Morgan, R.W., Christman, M.F., and Ames, B.M., 1989, An alkyl hydroperoxide reductase induced by oxidative stress in *Salmonella typhimurium* and *Escherichia coli*: genetic characterization and cloning of *ahp*. *J. Bacteriol.* **171**: 2049–2055.
- Jaeger, T., Budde, H., Flohé, L., Menge, U., Singh, M., Trujillo, M., and Radi, R., 2004, Multiple thioredoxin-mediated routes to detoxify hydroperoxides in *Mycobacterium tuberculosis*. *Arch. Biochem. Biophys.* **423**: 182–191.
- Jakubovics, N.S., Smith, A.W., and Jenkinson, H.F., 2002, Oxidative stress tolerance is manganese ( $Mn^{2+}$ ) regulated in *Streptococcus gordonii*. *Microbiol.* **148**: 3255–3263.
- Johnson, N.A., Liu, Y., and Fletcher, H.M., 2004, Alkyl hydroperoxide peroxidase subunit C (*ahpC*) protects against organic peroxides but does not affect the virulence of *Porphyromonas gingivalis* W83. *Oral Microbiol. Immunol.* **19**: 233–239.
- Jungblut, P.R., Bumann, D., Haas, G., Zimny-Arndt, U., Holland, P., Lamer, S., Siejak, F., Aebischer, A., and Meyer, T.F., 2000, Comparative proteome analysis of *Helicobacter pylori*. *Mol. Microbiol.* **36**: 710–725.
- Karupiah, G., Hunt, N.H., King, N.J., and Chaudhri, G., 2000, NADPH oxidase, Nramp1 and nitric oxide synthase 2 in the host antimicrobial response. *Rev. Immunogenet.* **2**: 387–415.
- Kim, S., Oog, Merchant, K., Nudelman, R., Beyer, W.F.J., Keng, T., DeAngelo, J., Hausladen, A., and Stamler, J.S., 2002, OxyR: a molecular code for redox-related signaling. *Cell* **109**: 383–396.
- King, K.Y., Horenstein, J.A., and Caparon, M.G., 2000, Aerotolerance and peroxide resistance in peroxidase and PerR mutants of *Streptococcus pyogenes*. *J. Bacteriol.* **182**: 5290–5299.
- Klomsiri, C., Panmanee, W., Dharmsthiti, S., Vattanaviboon, P., and Mongkolsuk, S., 2005, Novel roles of *ohrR-ohr* in *Xanthomonas* sensing, metabolism, and physiological adaptive response to lipid hydroperoxide. *J. Bacteriol.* **187**: 3277–3281.
- Kolenbrander, P.E., Andersen, R.N., Baker, R.A., and Jenkinson, H.F., 1998, The adhesion-associated *sca* operon in *Streptococcus gordonii* encodes an inducible high-affinity ABC transporter for  $Mn^{2+}$  uptake. *J. Bacteriol.* **180**: 290–295.
- Krayl, M., Benndorf, D., Loffhagen, N., and Babel, W., 2003, Use of proteomics and physiological characteristics to elucidate ecotoxic effects of methyl tert-butyl ether in *Pseudomonas putida* KT2440. *Proteomics* **3**: 1544–1552.
- Kullik, I., Toledano, M.B., Tartaglia, L.A., and Storz, G., 1995, Mutational analysis of the redox-sensitive transcriptional regulator OxyR: regions important for oxidation and transcriptional activation. *J. Bacteriol.* **177**: 1285–1291.
- Lambert, L.A., Ashbire, K., Blankenhorn, D., and Slonczewski, J.L., 1997, Proteins induced in *Escherichia coli* by benzoic acid. *J. Bacteriol.* **179**: 7595–7599.
- Leblanc, L., Leboeuf, C., Leroi, F., Hartke, A., and Yanick, A., 2003, Comparison between NaCl tolerance response and acclimation to cold temperature in *Shewanella putrefaciens*. *Curr. Microbiol.* **46**: 157–167.
- Lee, C., Lee, S., Mi, Mukhopadhyay, P., Kim, S., Jun, Lee, S., Chul, Ahn, W.-S., Yu, M.-H., Storz, G., and Ryu, S., Eon, 2004, Redox regulation of OxyR requires specific disulfide bond formation involving a rapid kinetic reaction path. *Nat. Struct. Biol.* **11**: 1179–1185.
- Lee, J.-W., and Helmann, J.D., 2006, The PerR transcription factor senses  $H_2O_2$  by metal-catalysed histidine oxidation. *Nature* **440**: 363–367.
- Lesniak, J., Barton, W.A., and Nikolov, D.B., 2002, Structural and functional characterization of the *Pseudomonas* hydroperoxide resistance protein Ohr. *EMBO J.* **21**: 6649–6659.
- Lesniak, J., Barton, W.A., and Nikolov, D.B., 2003, Structural and functional features of the *Escherichia coli* hydroperoxide resistance protein OsmC. *Protein Sci.* **12**: 2838–2843.
- Liu, S.X., Athar, M., Lippai, I., Waldren, C., and Hei, T.K., 2001, Induction of oxyradicals by arsenic: implication for mechanism of genotoxicity. *Proc. Natl. Acad. Sci. USA* **98**: 1643–1648.

- Loo, C.Y., Mitrakul, K., Jaafar, S., Gyurko, C., Hughes, C.V., and Ganeshkumar, N., 2004, Role of a *nosX* homolog in *Streptococcus gordonii* in aerobic growth and biofilm formation. *J. Bacteriol.* **186**: 8183–8206.
- Loprasert, S., Artichartpongkun, S., Whangsuk, W., and Mongkolsuk, S., 1997, Isolation and analysis of the *Xanthomonas* alkyl hydroperoxide reductase and the peroxide sensor regulator genes *ahpC* and *ahpF-oxvR-orfX*. *J. Bacteriol.* **179**: 3944–3949.
- Loprasert, S., Fuangthong, M., Whangsuk, W., Atichartpongkun, S., and Mongkolsuk, S., 2000, Molecular and physiological analysis of an OxyR-regulated *ahpC* promoter in *Xanthomonas campestris* pv. phaseoli. *Mol. Microbiol.* **37**: 1504–1514.
- Loprasert, S., Sallabhan, R., Whangsuk, W., and Mongkolsuk, S., 2003, Compensatory increase in *ahpC* gene expression and its role in protecting *Burkholderia pseudomallei* against reactive nitrogen intermediates. *Arch. Microbiol.* **180**: 498–502.
- Loprasert, S., Whangsuk, W., Sallabhan, R., and Mongkolsuk, S., 2004, DpsA protects the human pathogen *Burkholderia pseudomallei* against organic hydroperoxide. *Arch. Microbiol.* **182**: 96–101.
- Lundström, A.M., and Bolin, I., 2000, A 26 kDa protein of *Helicobacter pylori* shows alkyl hydroperoxide reductase (AhpC) activity and the mono-cistronic transcription of the gene is affected by pH. *Microb. Pathog.* **29**: 257–266.
- Lundström, A.M., Sundaeus, V., and Bolin, I., 2001, The 26-kilodalton, AhpC homologue, of *Helicobacter pylori* is also produced by other *Helicobacter* species. *Helicobacter* **6**: 44–54.
- Maalej, S., Dammak, I., and Dukan, S., 2006, The impairment of superoxide dismutase coordinates the derepression of the PerR regulon in the response of *Staphylococcus aureus* to HOCl stress. *Microbiol.* **152**: 855–861.
- Majdalani, N., and Gottesman, S., 2005, The Rcs phosphorelay: a complex signal transduction system. *Ann. Rev. Microbiol.* **59**: 379–405.
- Manca, C., Paul, S., Barry, C.E.I., Freedman, V.H., and Kaplan, G., 1999, *Mycobacterium tuberculosis* catalase and peroxidase activities and resistance to oxidative killing in human monocytes *in vitro*. *Infect. Immun.* **67**: 74–79.
- Maness, P.-C., Smolinski, S., Blake, D.M., Huang, Z., Wolfrum, E.J., and Jacoby, W.A., 1999, Bactericidal activity of photocatalytic TiO<sub>2</sub> reaction: toward an understanding of its killing mechanism. *Appl. Environ. Microbiol.* **65**: 4094–4098.
- Master, S.S., Springer, B., Sander, P., Boettger, E.C., Deretic, V., and Timmins, G.S., 2002, Oxidative stress response genes in *Mycobacterium tuberculosis*: role of *ahpC* in resistance to peroxynitrite and stage-specific survival in macrophages. *Microbiol.* **148**: 3139–3144.
- Meunier-Jamin, C., Kapp, U., Leonard, G.A., and McSweeney, S., 2004, The structure of the organic hydroperoxide resistance protein from *Deinococcus radiodurans*. Do conformational changes facilitate recycling of the redox disulfide. *J. Biol. Chem.* **279**: 25830–25837.
- Michan, C., Manchado, M., Dorado, G., and Pueyo, C., 1999, *In vivo* transcription of the *Escherichia coli* *oxyR* regulon as a function of growth phase and in response to oxidative stress. *J. Bacteriol.* **181**: 2759–2764.
- Mongkolsuk, S., and Helmann, J., D., 2002, Regulation of inducible peroxide stress responses. *Mol. Microbiol.* **45**: 9–15.
- Mongkolsuk, S., Loprasert, S., Whangsuk, W., Fuangthong, M., and Atichartpongkun, S., 1997, Characterization of transcription organization and analysis of unique expression patterns of an alkyl hydroperoxide reductase C gene (*ahpC*) and the peroxide regulator operon *ahpF-oxvR-orfX* from *Xanthomonas campestris* pv. phaseoli. *J. Bacteriol.* **179**: 3950–3955.
- Mongkolsuk, S., Praituan, W., Loprasert, S., Fuangthong, M., and Chamnongpol, S., 1998a, Identification and characterization of a new organic hydroperoxide resistance (*ohr*) gene with a novel pattern of oxidative stress regulation from *Xanthomonas campestris* pv. phaseoli. *J. Bacteriol.* **180**: 2636–2643.
- Mongkolsuk, S., Sukchawalit, R., Loprasert, S., Praituan, W., and Upaichit, A., 1998b, Construction and physiological analysis of a *Xanthomonas* mutant to examine the role of the *oxyR* gene in oxidant-induced protection against peroxide killing. *J. Bacteriol.* **180**: 3988–3991.
- Mongkolsuk, S., Whangsuk, W., Fuangthong, M., and Loprasert, S., 2000a, Mutations in *oxyR* resulting in peroxide resistance in *Xanthomonas campestris*. *J. Bacteriol.* **182**: 3846–3849.

- Mongkolsuk, S., Whangsuk, W., Vattanaviboon, P., Loprasert, S., and Fuangthong, M., 2000b, A *Xanthomonas* alkyl hydroperoxide reductase subunit C (*ahpC*) mutant showed an altered peroxide stress response and complex regulation of the compensatory response of peroxide detoxification enzymes. *J. Bacteriol.* **182**: 6845–6849.
- Morgan, R.W., Christman, M.F., Jacobson, F.S., Storz, G., and Ames, B.M., 1986, Hydrogen peroxide-inducible proteins in *Salmonella typhimurium* overlap with heat shock and other stress proteins. *Proc. Natl. Acad. Sci. USA* **83**: 8059–8063.
- Morrissey, J.A., Cockayne, A., Brummell, K., and Williams, P., 2004, The staphylococcal ferritins are differentially regulated in response to iron and manganese and via PerR and Fur. *Infect. Immun.* **72**: 972–979.
- Mostertz, J., Scharf, C., Hecker, M., and Homuth, G., 2004, Transcriptome and proteome analysis of *Bacillus subtilis* gene expression in response to superoxide and peroxide stress. *Microbiol.* **150**: 497–512.
- Mukhopadhyay, S., Miller, R.D., and Summersgill, J.T., 2004, Analysis of altered protein expression patterns of *Chlamydia pneumoniae* by an integrated proteome-works system. *J. Proteome Res.* **3**: 878–883.
- Nathan, C., and Shiloh, M.U., 2000, Reactive oxygen and nitrogen intermediates in the relationship between mammalian hosts and microbial pathogens. *Proc. Natl. Acad. Sci. USA* **97**: 8841–8848.
- Newman, E.B., and Lin, R., 1995, Leucine-responsive regulatory protein: a global regulator of gene expression in *E. coli*. *Ann. Rev. Microbiol.* **49**: 747–775.
- Ochsner, U.A., Hassett, D.J., and Vasil, M.L., 2001, Genetic and physiological characterization of *ohr*, encoding a protein involved in organic hydroperoxide resistance in *Pseudomonas aeruginosa*. *J. Bacteriol.* **183**: 773–778.
- Ochsner, U.A., Vasil, M.L., Eyad, A., Kislay, P., and Hassett, D.J., 2000, Role of the *Pseudomonas aeruginosa oxyR-recG* operon in oxidative stress defense and DNA repair: OxyR-dependent regulation of *katB-ankB*, *ahpB*, and *ahpC-ahpF*. *J. Bacteriol.* **182**: 4533–44.
- Ohara, N., Kikuchi, Y., Shoji, M., Naito, M., and Nakayama, K., 2006, Superoxide dismutase-encoding gene of the obligate anaerobe *Porphyromonas gingivalis* is regulated by the redox-sensing transcription activator OxyR. *Microbiol.* **152**: 955–966.
- Okano, S., Shibata, Y., Shiroza, T., and Abiko, Y., 2006, Proteomics-based analysis of a counter-oxidative stress system in *Porphyromonas gingivalis*. *Proteomics* **6**: 251–258.
- Olczak, A.A., Olson, J.W., and Maier, R.J., 2002, Oxidative-stress resistance mutants of *Helicobacter pylori*. *J. Bacteriol.* **184**: 3186–3193.
- Olczak, A.A., Seyler, R.W., Olson, J.W., and Maier, R.J., 2003, Association of *Helicobacter pylori* antioxidant activities with host colonization proficiency. *Infect. Immun.* **71**: 580–583.
- Old, I.G., Phillips, S.E.V., Stockley, P.G., and Saint Girons, I., 1991, Regulation of methionine biosynthesis in the *Enterobacteriaceae*. *Prog. Biophys. Mol. Biol.* **56**: 145–185.
- Oliveira, M.A., Guimares, B.G., Cussiol, J.R.R., Medrano, F.J., Gozzo, F.C., and Netto, L.E.S., 2006, Structural insights into enzyme-substrate interaction and characterization of enzymatic intermediates of organic hydroperoxide resistance protein from *Xylella fastidiosa*. *J. Mol. Biol.* **359**: 433–435.
- Olsen, I., Reitan, L.J., Holstad, G., and Wiker, H.G., 2000, Alkyl hydroperoxide reductases C and D are major antigens constitutively expressed by *Mycobacterium avium* subsp. *paratuberculosis*. *Infect. Immun.* **68**: 801–808.
- Olsen, I., Tryland, M., Wiker, H.G., and Reitan, L.J., 2001, AhpC, AhpD, and a secreted 14-kilodalton antigen from *Mycobacterium avium* subsp. *paratuberculosis* distinguish between paratuberculosis and bovine tuberculosis in an enzyme-linked immunosorbent assay. *Clin. Diagn. Lab. Immunol.* **8**: 797–801.
- Oram, D., Marra, Avdalovic, A., and Holmes, R.K., 2002, Construction and characterization of transposon insertion mutations in *Corynebacterium diphtheriae* that affect expression of the diphtheria toxin repressor (DtxR). *J. Bacteriol.* **184**: 5723–5732.
- Pagan-Ramos, E., Master, S.S., Pritchett, C.L., Reimschuessel, R., Trucksis, M., Timmins, G.S., and Deretic, V., 2006, Molecular and physiological effects of mycobacterial *oxyR* inactivation. *J. Bacteriol.* **188**: 2674–2680.



- Pagan-Ramos, E., Song, J., McFalone, M., Mudd, M.H., and Deretic, V., 1998, Oxidative stress response and characterization of the *oxyR-ahpC* and *furA-katG* loci in *Mycobacterium marinum*. *J. Bacteriol.* **180**: 4856–4864.
- Paget, M.S., and Buttner, M.J., 2003, Thiol-based regulatory switches. *Ann. Rev. Genet.* **37**: 91–121.
- Panmanee, W., Vattanaviboon, P., Eiamphungporn, W., Whangsuk, W., Sallabhan, R., and Mongkolsuk, S., 2002, OhrR, a transcription repressor that senses and responds to changes in organic peroxide levels in *Xanthomonas campestris* pv. phaseoli. *Mol. Microbiol.* **45**: 1647–1654.
- Panmanee, W., Vattanaviboon, P., Poole, L.B., and Mongkolsuk, S., 2006, Novel organic hydroperoxide-sensing and responding mechanisms for OhrR, a major bacterial sensor and regulator of organic hydroperoxide stress. *J. Bacteriol.* **188**: 1389–1395.
- Park, S., You, X., and Imlay, J.A., 2005, Substantial DNA damage from submicromolar intracellular hydrogen peroxide detected in Hpx- mutants of *Escherichia coli*. *Proc. Natl. Acad. Sci. USA* **102**: 9317–9322.
- Parsonage, D., Youngblood, D.S., Ganapathy, N.S., Wood, Z.A., Karpus, A.P., and Poole, L.B., 2005, Analysis of the link between enzymatic activity and oligomeric state in AhpC, a bacterial peroxiredoxin. *Biochemistry* **44**: 10583–10592.
- Pomposiello, P.J., and Demple, B., 2002, Global adjustment of microbial physiology during free radical stress. *Adv. Microb. Physiol.* **46**: 319–341.
- Poole, L.B., Higuchi, M., Shimada, M., Calzi, M., Li, and Kamio, Y., 2000a, *Streptococcus mutans* H<sub>2</sub>O<sub>2</sub>-forming NADH oxidase is an alkyl hydroperoxide reductase protein. *Free Rad. Biol. Med.* **28**: 108–120.
- Poole, L.B., Reynolds, C.M., Wood, Z.A., Karpus, A.P., Ellis, H.R., and Li Calzi, M., 2000b, AhpF and other NADH:peroxiredoxin oxidoreductases, homologues of low Mr thioredoxin reductase. *Eur. J. Biochem.* **267**: 6126–6133.
- Pym, A.S., Domenech, P., Honore, N., Song, J., Deretic, V., and Cole, S.T., 2001, Regulation of catalase-peroxidase (KatG) expression, isoniazid sensitivity and virulence by *furA* of *Mycobacterium tuberculosis*. *Mol. Microbiol.* **40**: 879–889.
- Rahav-Manor, O., Carmel, O., Karpel, R., Taglicht, D., Glaser, G., Schuldiner, S., and Padan, E., 1992, NhaR, a protein homologous to a family of bacterial regulatory proteins (LysR), regulates *nhaA*, the sodium proton antiporter gene in *Escherichia coli*. *J. Biol. Chem.* **267**: 10433–10438.
- Rankin, S., Li, Z., and Isberg, R.R., 2002, Macrophage-induced genes of *Legionella pneumophila*: protection from reactive intermediates and solute imbalance during intracellular growth. *Infect. Immun.* **70**: 3637–3648.
- Rehse, P.H., Ohshima, N., Nodake, Y., and Tahirov, T.H., 2004, Crystallographic structure and biochemical analysis of the *Thermus thermophilus* osmotically inducible protein C. *J. Mol. Biol.* **338**: 959–968.
- Rho, B.-S., Hung, L.-W., Holton, J.M., Vigil, D., Kim, S.-I., Park, M.S., Terwillinger, T.C., and Pedelacq, J.-D., 2006, Functional and Structural Characterization of a Thiol Peroxidase from *Mycobacterium tuberculosis*. *J. Mol. Biol.* **361**: 850–863.
- Rickman, L., Scott, C., Hunt, D.M., Hutchinson, T., Menendez, M.C., Whalan, R., Hinds, J., Colston, M.J., Green, J., and Buxton, R.S., 2005, A member of the cAMP receptor protein family of transcription regulators in *Mycobacterium tuberculosis* is required for virulence in mice and controls transcription of the *ppfA* gene coding for a resuscitation promoting factor. *Mol. Microbiol.* **56**: 1274–1286.
- Rince, A., Giard, J.-C., Pichereau, V., Flahaut, S., and Auffray, Y., 2001, Identification and characterization of *gsp65*, an organic hydroperoxide resistance (*ohr*) gene encoding a general stress protein in *Enterococcus faecalis*. *J. Bacteriol.* **183**: 1482–1488.
- Rocha, E.R., Owens, G.J., and Smith, C.J., 2000, The redox-sensitive transcriptional activator OxyR regulates the peroxide response regulon in the obligate anaerobe *Bacteroides fragilis*. *J. Bacteriol.* **182**: 5059–5069.
- Rocha, E.R., and Smith, C.J., 1998, Characterization of a peroxide-resistant mutant of the anaerobic bacterium *Bacteroides fragilis*. *J. Bacteriol.* **180**: 5906–5912.
- Rocha, E.R., and Smith, C.J., 1999, Role of the alkyl hydroperoxide reductase (*ahpCF*) gene in oxidative stress defense of the obligate anaerobe *Bacteroides fragilis*. *J. Bacteriol.* **181**: 5701–5710.

- Rosenkrands, I., King, A., Weldingh, K., Moniatte, M., Moertz, E., and Andersen, P., 2000a, Towards the proteome of *Mycobacterium tuberculosis*. *Electrophoresis* **21**: 3740–3756.
- Rosenkrands, I., Weldingh, K., Jacobsen, S., Hansen, C.V., Florio, W., Gianetri, I., and Andersen, P., 2000b, Mapping and identification of *Mycobacterium tuberculosis* proteins by two-dimensional gel electrophoresis, microsequencing and immunodetection. *Electrophoresis* **21**: 935–48.
- Rozwarski, D.A., Grant, G.A., Barton, D.H.R., Jacobs, W.R.J., and Sacchettini, J.C., 1998, Modification of the NADH of the isoniazid target (InhA) from *Mycobacterium tuberculosis*. *Science* **279**: 98–102.
- Schell, M.A., 1993, Molecular biology of the LysR family of transcriptional regulators. *Ann. Rev. Microbiol.* **47**: 597–626.
- Seaver, L.C., and Imlay, J.A., 2001, Alkyl hydroperoxide reductase is the primary scavenger of endogenous hydrogen peroxide in *Escherichia coli*. *J. Bacteriol.* **183**: 7173–7181.
- Semchyshyn, H., Bagnyukova, T., Storey, K., and Storey, V., 2005, Hydrogen peroxide increases the activities of *soxRS* regulon enzymes and the levels of oxidized proteins and lipids in *Escherichia coli*. *Cell Biol. Int.* **70**: 424–431.
- Shao, F., Bader, M.W., Jalob, U., and Bardwell, J.C.A., 2000, DsbG, a protein disulfide isomerase with chaperone activity. *J. Biol. Chem.* **275**: 13349–13352.
- Shea, R.J., and Mulks, M.H., 2002, *ohr*, Encoding an organic hydroperoxide reductase, is an *in vivo*-induced gene in *Actinobacillus pleuropneumoniae*. *Infect. Immun.* **70**: 794–802.
- Sherman, D.R., Mdhlu, K., Hickey, M.J., Arain, T.M., M., M.S., Barry, C.E.I., and Stover, C.K., 1996, Compensatory *ahpC* gene expression in isoniazid-resistant *Mycobacterium tuberculosis*. *Science* **272**: 1641–1643.
- Sherman, D.R., Mdhlu, K., Hickey, M.J., Barry, C.E.I., and Stover, C.K., 1999, AhpC, oxidative stress and drug resistance in *Mycobacterium tuberculosis*. *Biofactors* **10**: 211–217.
- Sherman, D.R., Sabo, P.J., Hickey, M.J., Arain, T.M., Mahairas, G.G., Yuan, Y., Barry, C.E.I., and Stover, C.K., 1995, Disparate responses to oxidative stress in saprophytic and pathogenic mycobacteria. *Proc. Natl. Acad. Sci. USA* **92**: 6625–6629.
- Shi, S., and Ehrh, S., 2006, Dihydroipoamide acyltransferase is critical for *Mycobacterium tuberculosis* pathogenesis. *Infect. Immun.* **74**: 56–63.
- Shin, D.H., Choi, I.-G., Busso, D., Jancarik, J., Yokota, H., Kim, R., and Kim, S.-H., 2004, Structure of OsmC from *Escherichia coli*: a salt-shock-induced protein. *Acta Crystallogr. D Biol. Crystallogr.* **60**: 903–911.
- Slonczewski, J.L., Mcgee, D.J., Phillips, J., Kirkpatrick, C., and Mobley, H.L.T., 2000, pH-dependent protein profiles of *Helicobacter pylori* analyzed by two-dimensional gels. *Helicobacter* **5**: 240–247.
- Spatofora, G., Van Hoeven, N., Wagner, K., and Fives-Taylor, P., 2002, Evidence that ORF3 at the *Streptococcus parasanguis fimA* locus encodes a thiol-specific antioxidant. *Microbiol.* **148**: 755–762.
- Springer, B., Sander, P., Zahrt, T., McFalone, M., Song, J., Papavinasasundaram, K.G., Colston, M.J., Boettger, E., and Deretic, V., 2001, Silencing of oxidative stress response in *Mycobacterium tuberculosis*: expression patterns of *ahpC* in virulent and avirulent strains and effect of *ahpC* inactivation. *Infect. Immun.* **69**: 5967–5973.
- Stancik, L.M., Stancik, D.M., Schmidt, B., Barnhart, D.M., Yoncheva, Y., N., and Slonczewski, J.L., 2002, pH-dependent expression of periplasmic proteins and amino acid catabolism in *Escherichia coli*. *J. Bacteriol.* **184**: 4246–4258.
- Staudinger, B.J., Oberdoerster, M.A., Lewis, P.J., and Rosen, H., 2002, mRNA expression profiles for *Escherichia coli* ingested by normal and phagocyte oxidase-deficient human neutrophils. *J. Clin. Invest.* **110**: 1151–1163.
- Storz, G., Christman, M.F., Sies, H., and Ames, B.M., 1987, Spontaneous mutagenesis and oxidative damage to DNA in *Salmonella typhimurium*. *Proc. Natl. Acad. Sci. USA* **84**: 8917–8921.
- Storz, G., Jacobson, F.S., Tartaglia, L.A., Morgan, R.W., Silveira, L.A., and Ames, B.M., 1989, An alkyl hydroperoxide reductase induced by oxidative stress in *Salmonella typhimurium* and *Escherichia coli*: genetic characterization and cloning of *ahp*. *J. Bacteriol.* **171**: 2049–2055.
- Storz, G., Tartaglia, L.A., and Ames, B.M., 1990, Transcriptional regulator of oxidative stress inducible genes: direct activation by oxidation. *Science* **248**: 189–194.

- Storz, G., and Zheng, M., 2000, Oxidative stress, in *Bacterial stress responses* (Storz, G. and Hengge-Aronis, R., eds.), American Society for Microbiology Press, Washington, DC, USA, pp. 47–59.
- Sturny, R., Cam, K., Gutierrez, C., and Conter, A., 2003, NhaR and RcsB independently regulate the *osmCp1* promoter of *Escherichia coli* at overlapping regulatory sites. *J. Bacteriol.* **185**: 4298–4304.
- Sukchawalit, R., Loprasert, S., Atichartpongkun, S., and Mongkolsuk, S., 2001, Complex regulation of the organic hydroperoxide resistance gene (*ohr*) from *Xanthomonas* involves OhrR, a novel organic peroxide-inducible negative regulator, and posttranscriptional modifications. *J. Bacteriol.* **183**: 4405–4412.
- Tai, S.S., and Zhu, Y., Yi, 1995, Cloning of a *Corynebacterium diphtheriae* iron-repressible gene that shares sequence homology with the AhpC subunit of alkyl hydroperoxide reductase of *Salmonella typhimurium*. *J. Bacteriol.* **177**: 3512–3517.
- Tartaglia, L.A., Storz, G., and Ames, B.M., 1989, Identification and molecular analysis of *oxyR*-regulated promoters important for the bacterial adaptation to oxidative stress. *J. Mol. Biol.* **210**: 709–719.
- Tartaglia, L.A., Storz, G., Brodsky, M.H., Lai, A., and Ames, B.M., 1990, Alkyl hydroperoxide reductase from *Salmonella typhimurium*. Sequence and homology to thioredoxin reductase and other flavoprotein disulfide oxidoreductases. *J. Biol. Chem.* **265**: 10535–10540.
- Taylor, P.D., Inchley, C.J., and Gallagher, M.P., 1998, The *Salmonella typhimurium* AhpC polypeptide is not essential for virulence in BALB/c mice but is recognized as an antigen during infection. *Infect. Immun.* **66**: 3207–3217.
- Tellez-Sosa, J., Soberon, N., Vega-Segura, A., Torres-Marquez, M.E., and Cevallos, M.A., 2002, The *Rhizobium etli* *cyaC* product: characterization of a novel adenylate cyclase class. *J. Bacteriol.* **184**: 3560–3568.
- Toesca, I., Perard, C., Bouvier, J., Gutierrez, C., and Conter, A., 2001, The transcriptional activator NhaR is responsible for the osmotic induction of *osmC(P1)*, a promoter of the stress-inducible gene *osmC* in *Escherichia coli*. *Microbiol.* **147**: 2795–2803.
- Toledano, M.B., Kullik, I., Trinh, F., Baird, P.T., Schneider, T.D., and Storz, G., 1994, Redox-dependent shift of OxyR-DNA contacts along an extended DNA-binding site: a mechanism for differential promoter selection. *Cell* **78**: 897–909.
- van Vliet, A.H.M., Baillon, M.-L.A., Penn, C.W., and Ketley, J.M., 1999, *Campylobacter jejuni* contains two *fur* homologs: characterization of iron-responsive regulation of peroxide stress defense genes by the PerR repressor. *J. Bacteriol.* **181**: 6371–6376.
- Vattanaviboon, P., Whangskul, W., Panmanee, W., Klomsiri, C., Dharmstithi, S., and Mongkolsuk, S., 2002, Evaluation of the roles that alkyl hydroperoxide reductase and Ohr play in organic peroxide-induced gene expression and protection against organic peroxides in *Xanthomonas campestris*. *Biochem. Biophys. Res. Commun.* **299**: 177–182.
- Verneuil, N., Le Breton, Y., Hartke, A., Auffray, Y., and Giard, J.-C., 2004a, Identification of a new oxidative stress transcriptional regulator in *Enterococcus faecalis*. *Lait.* **84**: 69–76.
- Verneuil, N., Sanguinetti, M., Le Breton, Y., Posteraro, B., Fadda, G., Auffray, Y., Hartke, A., and Giard, J.-C., 2004b, Effects of the *Enterococcus faecalis* *hypR* gene encoding a new transcriptional regulator on oxidative stress response and intracellular survival within macrophages. *Infect. Immun.* **72**: 4424–4431.
- Verneuil, N., Rince, A., Sanguinetti, M., Auffray, Y., Hartke, A., and Giard, J.-C., 2005, Implication of *hypR* in the virulence and oxidative stress response of *Enterococcus faecalis*. *FEMS Microbiol. Lett.* **252**: 137–141.
- Volker, U., Maul, B., and Hecker, M., 1998, One of two *osmC* homologs in *Bacillus subtilis* is part of the sigmaB-dependent general stress regulon. *J. Bacteriol.* **180**: 4212–4218.
- Wan, X.-Y., Zhou, Y., Yan, Z.-Y., Wang, H.-L., Hou, Y.-D., and Jin, D.-Y., 1997, Scavengase p20: a novel family of bacterial antioxidant enzymes. *FEBS Lett.* **407**: 32–36.
- Wang, G., Conover, R.C., Benoit, S., Olczak, A.A., Olson, J.W., Johnson, M.K., and Maier, R.J., 2004, Role of a bacterial organic hydroperoxide detoxification system in preventing catalase inactivation. *J. Biol. Chem.* **279**: 51908–51914.
- Wang, G., Conover, R.C., Olczak, A.A., Alamuri, P., Johnson, M.K., and Maier, R.J., 2005, Oxidative stress defense mechanisms to counter iron-promoted DNA damage in *Helicobacter pylori*. *Free Rad. Res.* **39**: 1183–1191.

- Wang, G., and P., D.M., 1998, Heat shock response enhances acid tolerance of *Escherichia coli* O157:H7. *Lett Appl Microbiol* **26**: 31–34.
- Weldingh, K., Rosenkrands, I., Jacobsen, S., Rasmussen, P.B., Elhay, M.J., and Andersen, P., 1998, Two-dimensional electrophoresis for analysis of *Mycobacterium tuberculosis* culture filtrate and purification and characterization of six novel proteins. *Infect. Immun.* **66**: 3492–3500.
- Wilkinson, S.P., and Grove, A., 2006, Ligand-responsive transcriptional regulation by members of the MarR family of winged helix proteins. *Curr. Issues Mol. Biol.* **8**: 51–62.
- Williams, C.H., Arscott, L.D., Müller, S., Lennon, B.W., Ludwig, M.L., Wang, P.-F., Veine, D.M., Becker, K., and Schirmer, R.H., 2000, Thioredoxin reductase two modes of catalysis have evolved. *Eur. J. Biochem.* **267**: 6110–6117.
- Wilson, T., de lisle, G.W., Marcinkeviciene, J.A., Blanchard, J.S., and Collins, D.M., 1998, Antisense RNA to *ahpC*, an oxidative stress defence gene involved in isoniazid resistance, indicates that AhpC of *Mycobacterium bovis* has virulence properties. *Microbiol.* **144**: 2687–2695.
- Windle, H.J., Ang, Y.S., Athie-Morales, V., McManus, R., and Kelleher, D., 2006, Human peripheral and gastric lymphocyte responses to *Helicobacter pylori* NapA and AhpC differ in infected and uninfected individuals. *Gut* **54**: 25–32.
- Wood, Z.A., Poole, L.B., Hantgan, R.R., and Karpus, A.P., 2002, Dimers to doughnuts: redox-sensitive oligomerization of 2-cysteine peroxiredoxins. *Biochemistry* **41**: 5493–5504.
- Wood, Z.A., Schroeder, E., Harris, J.R., and Poole, L.B., 2003, Structure, mechanism and regulation of peroxiredoxins. *Trends Biochem. Sci.* **28**: 32–40.
- Yamaguchi, R., Matsuo, K., Yamazaki, A., Takahashi, M., Fukasawa, Y., Wada, M., and Abe, C., 1992, Cloning and expression of the gene for the Avi-3 antigen of *Mycobacterium avium* and mapping of its epitopes. *Infect. Immun.* **60**: 1210–1216.
- Yamamoto, Y., 2000a, Molecular biology of oxygen tolerance in lactic acid bacteria: Functions of NADH oxidases and Dpr in oxidative stress. *Biosci Biotech Biochem* **90**: 484–493.
- Yamamoto, Y., Higuchi, M., Poole, L.B., and Kamio, Y., 2000b, Role of the *dpr* product in oxygen tolerance in *Streptococcus mutans*. *J. Bacteriol.* **182**: 3740–3747.
- Zarht, T.C., and Deretic, V., 2002, Reactive nitrogen and oxygen intermediates and bacterial defenses: unusual adaptations in *Mycobacterium tuberculosis*. *Antioxid. Redox Signal.* **4**: 141–159.
- Zhang, Y., Dhandayuthapani, S., and Deretic, V., 1996, Molecular basis for the exquisite sensitivity of *Mycobacterium tuberculosis* to isoniazid. *Proc. Natl. Acad. Sci. USA* **93**: 13212–13216.
- Zhang, Y., Heym, B., Allen, B., Young, D., and Cole, S., 1992, The catalase-peroxidase gene and isoniazid resistance of *Mycobacterium tuberculosis*. *Nature* **358**: 591–593.
- Zhao, X., Yu, H., Yu, S., Wang, F., Sacchettini, J.C., and Magliozzo, R.S., 2006, Hydrogen peroxide-mediated isoniazid activation catalyzed by *Mycobacterium tuberculosis* catalase-peroxidase (KatG) and its S315T mutant. *Biochemistry* **45**: 4131–4140.
- Zheng, M., Aslund, F., and Storz, G., 1998, Activation of the OxyR transcription factor by reversible disulfide bond formation. *Science* **279**: 1718–1721.
- Zheng, M., and Storz, G., 2000, Redox sensing by prokaryotic transcription factors. *Biochem. Pharmacol.* **59**: 1–6.
- Zheng, M., Wang, X., Doan, B., Lewis, K.A., and Schneider, T.D., 2001a, Computation-directed identification of OxyR DNA binding sites in *Escherichia coli*. *J. Bacteriol.* **183**: 4571–4591.
- Zheng, M., Wang, X., Templeton, L.J., Smulski, D.R., LaRossa, R.A., and Storz, G., 2001b, DNA microarray-mediated transcriptional profiling of the *Escherichia coli* response to hydrogen peroxide. *J. Bacteriol.* **183**: 4562–4570.
- Zhou, Y., Wan, X.-Y., Wang, H.-L., Yan, Z.-Y., Hou, Y.-D., and Jin, D.-Y., 1997, Bacterial scavengase p20 is structurally and functionally related to peroxiredoxins. *Biochem. Biophys. Res. Commun.* **233**: 848–852.

## CHAPTER 8

# THE NADH OXIDASE-PRX SYSTEM IN *AMPHIBACILLUS XYLANUS*

YOUICHI NIIMURA

*Department of Bioscience, Tokyo University of Agriculture, Tokyo Japan*

**Abstract:** *Amphibacillus* NADH oxidase belongs to a growing new family of peroxiredoxin-linked oxidoreductases including alkyl hydroperoxide reductase F (AhpF). Like AhpF it displays extremely high hydroperoxide reductase activity in the presence of a Prx, thus making up the NADH oxidase-Prx system. The NADH oxidase primarily catalyzes the reduction of oxygen by NADH to form H<sub>2</sub>O<sub>2</sub>, while the Prx immediately reduces H<sub>2</sub>O<sub>2</sub> (or ROOH) to water (or ROH). Consequently, the NADH oxidase-Prx system catalyzes the reduction of both oxygen and hydrogen peroxide to water with NADH as the preferred electron donor. The NADH oxidase-Prx system is widely distributed in aerobically growing bacteria lacking a respiratory chain and catalase, and plays an important role not only in scavenging hydroperoxides but also in regenerating NAD in these bacteria

**Keywords:** Peroxiredoxin, Prx, Peroxiredoxin reductase, NADH oxidase, Alkyl hydroperoxide reductase, AhpF, *Amphibacillus xylanus*

### 1. INTRODUCTION

In 1987 we isolated a new group of facultatively anaerobic bacteria from alkaline compost (Niimura *et al.*, 1987) and named one of the isolates *Amphibacillus xylanus* (Niimura *et al.*, 1990). *A. xylanus* has the same growth rate and cell yield both under strictly anaerobic and under aerobic conditions (Fig. 1) (Niimura *et al.*, 1990). This implies the presence of anaerobic and aerobic pathways that produce similar amounts of ATP (Niimura *et al.*, 1989). In addition, effective systems to regenerate NAD and to eliminate peroxides should be present to allow growth under aerobic conditions. *A. xylanus*, however, lacks a respiratory chain and heme proteins, including catalase and KatG-type catalases/peroxidases. We indeed could purify an NADH oxidase from aerobically grown *A. xylanus* that regenerated NAD but also produced hydrogen peroxide (Niimura *et al.*, 1993). We later found that the H<sub>2</sub>O<sub>2</sub> thus formed is reduced by an AhpC-type protein, which is a member of the expanding new family of antioxidant proteins, the peroxiredoxins (Prxs) (Niimura *et al.*, 1995).

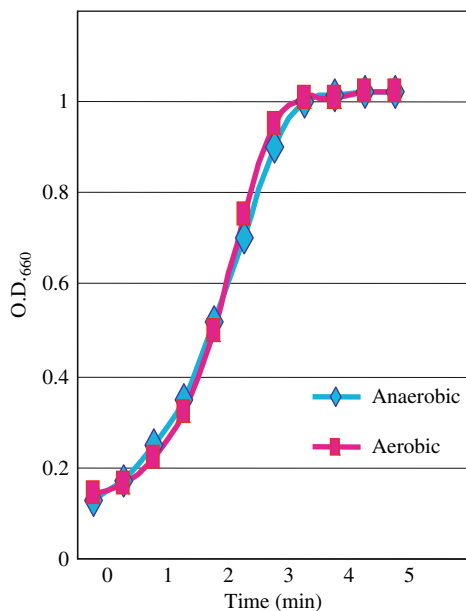

Figure 1. Growth of *Amphibacillus xylanus* under anaerobic and aerobic conditions (See Plate 15)

The amino acid sequence of *A. xylanus* NADH oxidase exhibits up to 51.2% identity with the alkyl hydroperoxide reductase F-52a flavoprotein component (AhpF) from *Salmonella enterica* (Niimura *et al.*, 1993), but the ability of the latter to reduce  $H_2O_2$  had not been clarified (Jacobson *et al.*, 1989; see also Chapter 1). We showed that both enzymes require the presence of a Prx and suitable ionic strength to reduce not only alkyl hydroperoxides but also  $H_2O_2$  (Niimura *et al.*, 1995). Moreover, the turnover numbers of the reactions catalyzed by the combined enzymes were extremely high when compared with known peroxide-scavenging enzymes (Niimura *et al.*, 1995). Although NADH oxidase and AhpF belong to the same peroxiredoxin:oxidoreductase family, the *A. xylanus* NADH oxidase-Prx system appears unique in respect to its reaction with oxygen and to play a particularly important role in the metabolic pathways characteristic of aerobically growing bacteria that lack a respiration chain and catalase (Niimura *et al.*, 2000; Nishiyama *et al.*, 2001). This article has two objectives: 1) to present the reaction mechanism of NADH oxidase-Prx system and 2) its physiological role.

## 2. REACTION MECHANISM OF THE NADH OXIDASE-PEROXIREDOXIN SYSTEM

The complete reduction of the NADH oxidase by dithionite requires 6 electron equivalents/mol of enzyme-bound flavin (Ohnishi *et al.*, 1994). Such behavior indicated the presence of redox centers in addition to FAD, and these were

identified as the two disulfides, Cys128-Cys131 and Cys337-Cys340. Dithionite titrations and steady-state kinetics of wild-type and mutant enzymes indicated that the electrons pass from enzyme-bound FAD through the primary reacting disulfide, Cys337-Cys340, to the second disulfide, Cys128-Cys131 (Ohnishi *et al.*, 1995).

## 2.1. Reaction Mechanism of Hydrogen Peroxide Reduction

In the presence of Prx, which does indeed exist in the cells of *A. xylanus* and is induced markedly under aerobic conditions, NADH oxidase shows potent peroxidase activity. In the reaction with Prx, the electrons from enzyme-bound FADH<sub>2</sub> have been shown to pass through the primary reacting disulfide, Cys 337-Cys340 to directly reduce the disulfide of Prx. Alternatively, the reduction equivalents sequentially reduce the Prx, first passing through the second reacting disulfide, Cys128-Cys131 (Niimura *et al.*, 1996).

Our initial conclusion that the second disulfide, Cys128-Cys131, was reduced too slowly to be involved in Prx reduction proved to be incorrect (Niimura *et al.*, 1996), because of the presence of damaged/denatured enzyme present in the sample of wild-type enzyme used in the initial experiments. Later experiments, carried out with freshly prepared NADH oxidase, consistently showed a fast reduction of the enzyme coupled with the consumption of 3 mol NADH per mol enzyme-bound FAD, suggesting that Cys128-Cys131 as well as Cys 337-Cys340 can reduce the disulfide bond of the Prx. Moreover, no reduction of H<sub>2</sub>O<sub>2</sub> and alkyl hydroperoxide was found with single and double mutants of Cys128 and Cys131, (C131S and C128S/C131S) (Niimura *et al.*, 1999), corroborating that this disulfide has to be reduced for interaction with Prx.

If this concept is correct, the single mutant form, which contains the free thiolate responsible for the interaction with Prx, is expected to form a stable cross-link between the two proteins. Immunoblot analysis of mixtures of Prx and mutant NADH oxidase C131S indeed revealed the presence of protein bands reacting with antibodies against both NADH oxidase and Prx (Niimura *et al.*, 1999). These bands showed two distinct N-terminal amino acid sequences corresponding to those of NADH oxidase and Prx, MLDKD and SLIGT, respectively. Formation of these bands was enhanced by the presence of NADH, but disappeared in the presence of the disulfide reducer, 2-mercaptoethanol. These results confirm that, at least in the mutant C131S, the free thiolate of Cys128 is the residue that attacks the disulfide bond of the Prx (Niimura *et al.*, 1999). Complex formation of the two proteins presumably favors a rapid thiol-disulfide interchange between Cys128 and the Prx rather. In short, therefore, the flux of reduction equivalents is NADH → enzyme-bound FAD → C337-C340 → C128-C131 → Prx (Fig. 2), which complies with reaction scheme worked out for alkyl hydroperoxide reductase from *Salmonella enterica* by Poole and co-workers (Calzi *et al.*, 1997; Poole *et al.*, 2000b). At saturating concentration of Prx, the  $V_{max}$  value for hydrogen peroxide reduction is similar to the rate of reduction of the enzyme-bound FAD by NADH in the *Amphibacillus* NADH oxidase system, suggesting that the overall turnover is limited

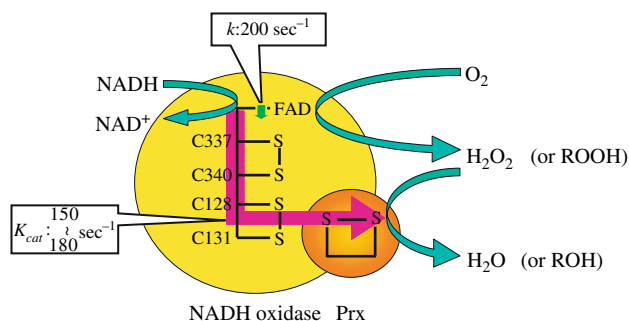

Figure 2. The NADH oxidase-Prx system shows extremely high hydroperoxide reductase activity and NADH oxidase activity (See Plate 16)

by the reduction of the flavoprotein component (Niimura *et al.*, 1996). The  $K_m$  values for hydrogen peroxide and cumene hydroperoxide in NADH oxidase-Prx system are too low for determination of their values by the spectroscopic analysis employed (Niimura *et al.*, 1995). The exceptionally high turnover numbers and low  $K_m$  values of the enzyme system are unusual among known peroxide-reducing enzymes which I investigated in publications (Niimura *et al.*, 1995).

## 2.2. Reaction Mechanism of Oxygen Reduction

The NADH oxidase activity of *Amphibacillus* enzyme is conspicuously high as compared with that of *Salmonella* AhpF (Niimura *et al.*, 1995). For the NADH oxidase reaction, the  $K_m$  values for NADH and oxygen, and the  $k_{cat}$  values of the three mutant enzymes, C337S, C340S and C337S/C340S, which are mutated at the first reacting disulfide, were not different from those of the wild-type enzyme (Ohnishi *et al.*, 1995). In our early reports, the apparent  $K_m$  value for oxygen were found to be 1.7 mM, which appears too high to efficiently catalyze the oxidation of NADH by oxygen in the cell (Ohnishi *et al.*, 1995). In the presence of additional FAD, however, the NADH oxidase activity was markedly accelerated and the  $K_m$  value for oxygen was greatly diminished. Indeed, it was too low to allow its accurate determination by the usual assay method (Fig. 3, inset) (Nishiyama *et al.*, 2001). In *A. xylanus* an intracellular FAD concentration of 13  $\mu$ M was determined, a concentration amply sufficient to stimulate the NADH oxidase activity (Nishiyama *et al.*, 2001). In the presence of high FAD, the isolated NADH oxidase (without the Prx) also seemed to display a peroxidase activity (Niimura *et al.*, 1994). This “peroxidase activity”, however, could be attributed to the reduction of peroxide by  $FADH_2$  formed in the flavin reductase reaction and thus is not enzyme-catalyzed. Also, The non-enzymatic reduction of  $H_2O_2$  is much slower than the competing enzymatic reaction of  $FADH_2$  with oxygen to produce  $H_2O_2$  and thus cannot account for the peroxidase activity of the complete system (Niimura *et al.*, 2000).



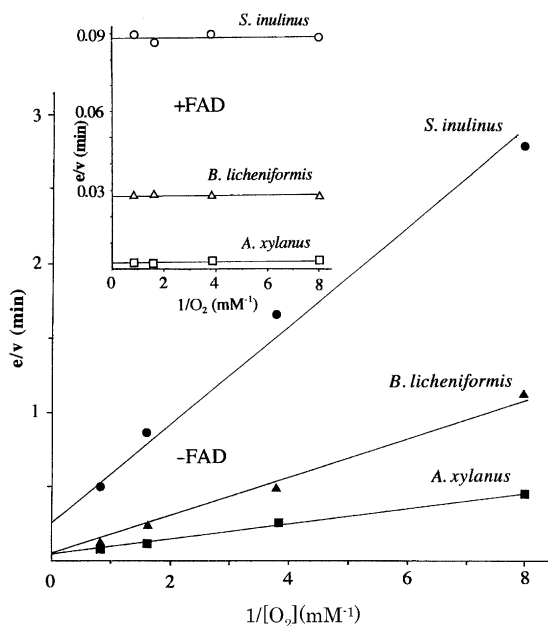

Figure 3. Lineweaver-Burk plots of steady-state kinetic analyses of purified NADH oxidase with or without FAD from indicated species

Taken together, our results demonstrate that i) the flavoprotein component of the system acts as an NADH oxidase that forms  $H_2O_2$  as an obligatory intermediate, ii) the Prx component is responsible for the of the strong peroxidase activity of the system, and iii) both components complement each other to build up an NADH oxidase that reduces molecular oxygen to water concomitantly oxidizing NADH to NAD. In the complete system, the hydrogen peroxide, which is formed as an intermediate, is removed by the Prx almost instantly. Indeed,  $H_2O_2$  is neither detected in an aerobic reaction mixture containing the system reconstituted from purified NADH oxidase and Prx nor in the medium of aerobically grown *A. xylanus* (Niimura *et al.*, 2000). Thus, the NADH oxidase-Prx system, in the presence of FAD, catalyzes the 4-electron reduction of oxygen to water under physiological conditions (Nishiyama *et al.*, 2001).

### 2.3. Supramolecular Organization of the System

The NADH oxidase-Prx system composed of two individual proteins contains a total of four-redox centers and evidently shows a hydroperoxide reductase activity that is efficient enough to prevent any accumulation of hydroperoxide which is formed as intermediate of the overall reaction. This observation suggests that the NADH oxidase and the Prx intimately interact with each other.

We reported on the oligomeric nature of *Amphibacillus* Prx, as evidenced by preliminary X-ray crystallography, dynamic light scattering (DLS) and turnover activity assays (Kitano *et al.*, 1999; Kitano *et al.*, 2005). This analytical data confirmed that Prx undergoes decamerization (approximately 200 kDa) at an ionic strength exceeding 360 meq (120 mM ammonium sulfate). Similarly, Poole and colleagues demonstrated an oligomerization of *Salmonella* Prx that, however, was primarily redox sensitive, the reduced enzyme strongly favoring decamer formation (Wood *et al.*, 2002). The *Amphibacillus* NADH oxidase forms a dimer (approximately 100 kDa) irrespective of ionic strength in the absence of Prx. However, DLS measurements indicated that, with increasing ionic strength, a large oligomeric assembly is formed in a mixture of NADH oxidase and Prx that finally reaches a mass of approximately 300 kDa at 500 mM ammonium sulfate; (Fig. 4; Arai *et al.*, 2005; Arai, unpublished data). Between 150 mM and 300 mM ammonium sulfate two protein bands are present in non-reducing SDS-PAGE, each reacting with both anti-NADH oxidase antibody and anti-Prx antibody. The protein bands on the SDS-PAGE are composed of NADH oxidase and Prx at ratios 2 : 2 and 1 : 2 for NADH oxidase: Prx, as determined by N-terminal amino acid sequence analysis of the two proteins (Arai *et al.*, 2005). The protein band corresponding to the mass that consists of equal molar ratio of NADH oxidase and Prx tends to increase at high ionic strength, suggesting that the 300 kDa assembly contains an equivalent molar mixture of NADH oxidase and Prx, probably 4:4; (Arai, unpublished data).

These protein bands clearly disappear in the presence of a disulfide reducer. Also, no such high molecular mass band was found with the NADH oxidase mutant C480S, even under non-reducing conditions. The hydroperoxide reductase activity of the Prx, however, was not affected by the presence of the mutant enzyme, remaining essentially identical to that of the mixture of wild-type NADH oxidase and Prx (Takeda *et al.*, 2002). These findings indicate that Cys480 of

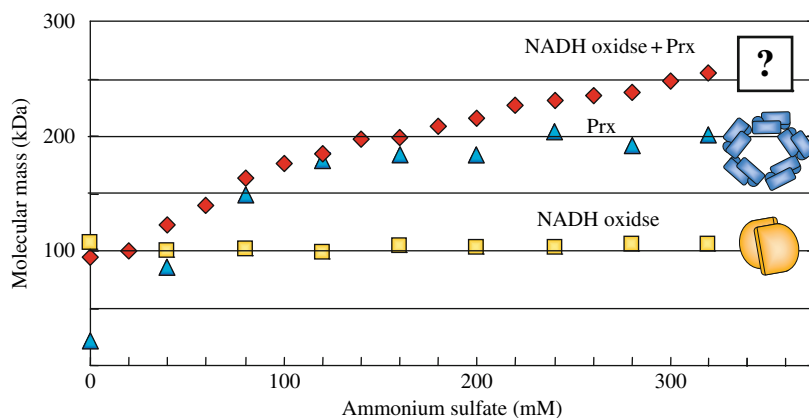

Figure 4. Large oligomeric assembly formation in the mixture of NADH oxidase and Prx determined by Dynamic Light Scattering (DLS). The ratio of NADH oxidase:Prx was 1:1 (subunit per subunit) (See Plate 17)

the NADH oxidase forms a stable cross-linkage with the Prx, but is not engaged in electron transfer from the NADH oxidase to Prx. Interestingly, the oligomeric assembly of the mutant enzyme C480S is unaltered as compared to that of the wild-type NADH oxidase, when assessed by DLS mass determination. Apparently NADH oxidase and Prx interact with each other to produce the non-covalent oligomeric assembly observed by DLS measurement. Under the denaturing conditions, however, Cys480 of NADH oxidase may be linked to a cysteine residue of Prx to form the disulfide-bridged complex observed in SDS-PAGE. Complex formation between NADH oxidase and Prx was also observed by surface plasmon resonance and ultra centrifuge analysis; (Zako, unpublished data). As the genes of these two proteins reside close to each other, their syntheses are likely co-ordinated, which should also facilitate a mutual interaction to form functional complexes in living cells of *A. xylanus*.

### 3. PHYSIOLOGICAL ROLE OF THE NADH OXIDASE-PRX SYSTEM

The NADH oxidase-Prx system is an efficient scavenging system for H<sub>2</sub>O<sub>2</sub> and other hydroperoxides. In so far the enzymatic system can compensate for the lack of catalase in bacteria devoid of heme synthesis such as *A. xylanus*. The system, however, appears equally important to compensate for a second consequence of the missing heme synthesis: the absence of a respiratory chain. In aerobically growing *A. xylanus*, NADH produced both from the glycolytic pathway and by pyruvate metabolism has to be removed, i.e. regenerated to NAD, to keep the aerobic metabolism in appropriate balance (Fig. 5A) (Nishiyama *et al.*, 2001). Similarly, *Sporolactobacillus inulinus*, another bacterium lacking a respiratory chain and catalase, grows well under both anaerobic and aerobic conditions, as does *A. xylanus*, and equally is equipped with a Prx and an NADH oxidase showing characteristics comparable to that of the *Amphibacillus* system (Nishiyama *et al.*, 1997). Therefore, also in this bacterium the NADH oxidase-Prx system probably plays an important role not only in removing peroxides but also in regenerating NAD during aerobic metabolism (Fig. 5B) (Nishiyama *et al.*, 2001). A further example may be the NADH oxidase/Prx system of *Streptococcus mutans* described by Poole *et al.* (2000a). In *Streptococcus mutans*, which also lacks catalase and a respiratory chain, the homologous enzyme system is thought to be bifunctional too.

The genes encoding proteins related to NADH, which comprise the AhpF-type proteins, are widely distributed among aerobically growing bacteria. However, the actual expression of these genes is not generally clear nor is the function of the expressed protein known in most of the cases. We therefore investigated the activity of the enzyme system in 15 strains comprising typical aerobic, facultatively anaerobic, and anaerobic bacteria. As a rule, high Prx-linked peroxide reductase activities were observed in cell-free extracts from bacterial species that grow well under aerobic conditions, irrespective of the presence of a respiratory chain, indicating that the Prx-linked peroxidase system is widely distributed in

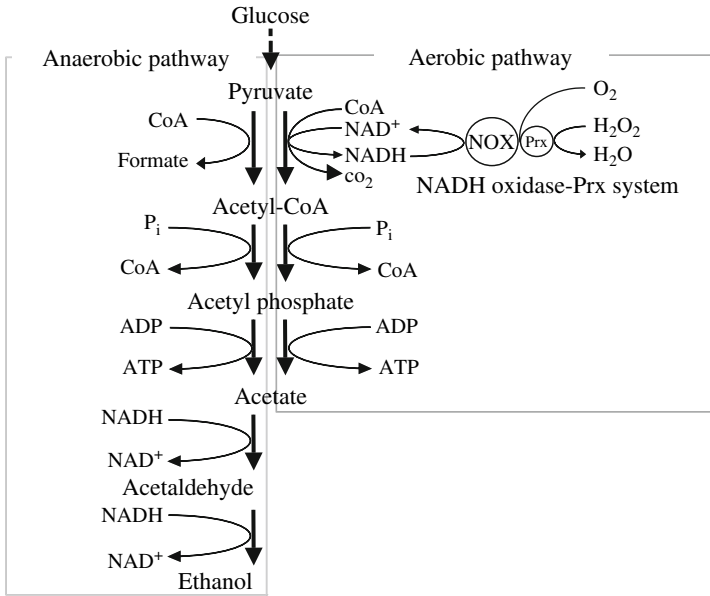

Figure 5A. The metabolic pathway for pyruvate metabolism in *Amphibacillus xylanus*

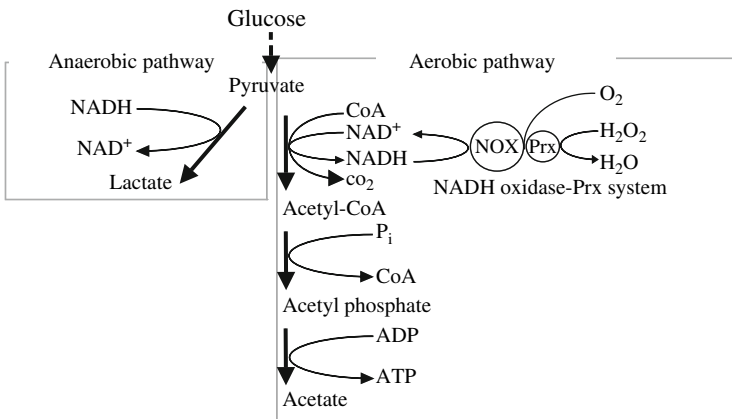

Figure 5B. The proposed pathway for pyruvate metabolism in *Sporolactobacillus inulinus*

aerobically growing bacterial cells (Nishiyama *et al.*, 2001). Also the  $V_{max}$  values of the purified Prx-linked enzymes are similar to that of *Amphibacillus* enzyme (Table 1), (Nishiyama *et al.*, 2001). However, the NADH oxidase activities of the *Salmonella* AhpF (Niimura *et al.*, 1995) and the *Bacillus* NADH dehydrogenase (Koyama *et al.*, 1998) - both bacteria having a respiratory chain - are

Table 1. Peroxide reductase activities of purified NADH oxidase and AhpF in the presence of Prx

Enzyme	$V_{\max}$ ( $\text{min}^{-1}$ )	
	Hydrogen peroxide	Cumene hydroperoxide
<i>Amphibacillus xylanus</i> NADH oxidase <sup>a</sup>	8,900	8,900
<i>Bacillus licheniformis</i> NADH oxidase <sup>b</sup>	9,200	9,300
<i>Sporolactobacillus inulinus</i> NADH oxidase <sup>c</sup>	9,300	8,300
Alkaliphilic <i>Bacillus</i> NADH dehydrogenase <sup>d</sup>	8,300	10,000
<i>Salmonella enterica</i> serovar <i>Typhimurium</i> alkyl hydroperoxide reductase <sup>e</sup>	14,900	14,300

The  $V_{\max}$  values of each purified enzymes were estimated in same temperature-controlled stopped-flow spectrophotometer system (<sup>b</sup>Nishiyama *et al.*, 2001). The concentration of the peroxides and Prx were from 0.1 to 1 mM, and 35  $\mu\text{M}$ , respectively.

<sup>a</sup> Niimura *et al.*, 2000;

<sup>b</sup> Nishiyama *et al.*, 2001;

<sup>c</sup> Niimura *et al.*, 1997;

<sup>d</sup> Koyama *et al.*, 1998;

<sup>e</sup> Niimura *et al.*, 1995

lower than those of the homologous enzymes from *Amphibacillus xylanus* and *Sporolactobacillus inulinus* (Nishiyama *et al.*, 1997). For the bacteria having respiratory chain it would be advantageous to have an AhpF which does not readily react with oxygen and thus to minimize consumption of NADH and formation of  $\text{H}_2\text{O}_2$ . In contrast, bacteria devoid of a respiratory chain would benefit from an NADH oxidase which is capable of utilizing oxygen for regeneration of NAD *via*  $\text{H}_2\text{O}_2$ -dependent and Prx-catalyzed NADH oxidation. Thus, it is intriguing to assume that bacteria have evolved the NADH oxidase-Prx system in order to adapt themselves to the aerobic environment for survival and maintenance of a competitive growth rate.

#### 4. CONCLUSIONS

The *Amphibacillus* NADH oxidase-Prx system shows both high hydroperoxide reductase activity and high NADH oxidase activity, consequently catalyzing the direct 4 electron reduction of oxygen to water. The unique bifunctionality of the enzyme system is thought to be essential not only for *Amphibacillus xylanus* but also for the wide variety of bacterial species lacking a respiratory chain and catalase in order to grow in aerobic conditions.

#### ACKNOWLEDGMENTS

The author greatly thanks the late Dr. Vincent Massey at The University of Michigan for assistance and valuable advice. The author also thanks the late Dr. Michio Kozaki at Tokyo University of Agriculture, and Dr. Takeshi Nishino at Nippon

Medical School for helpful suggestions and valuable advice, and is grateful to Dr. Kenji Ohnishi, Dr. Yoshitaka Nishiyama, Dr. Shinji Kawasaki, Dr. Kouji Takeda, Seiichi Sasaki, Masazumi Asano, Masato Date, Akihiro Sato, and Toshiaki Arai at Tokyo University of Agriculture for valuable assistance, and Dr. Junichi Nakagawa at Tokyo University of Agriculture for helpful suggestions and critical reading of the manuscript.

This work was supported in part by a grant from the Japanese Ministry of Education, Science, Sports and Culture of Japan.

## REFERENCES

- Arai, T., Date, M., Sato, A., Asano, M., Watanabe, T., Zako, T., Odaka, M., Yohda, M., Takeda, K., Nakagawa, J., Kawasaki, S., and Niimura, Y., 2005, The NADH oxidase-Prx system functional as NADH oxidase and alkylhydroperoxide reductase. Protein interaction and physiological role in *Amphibacillus*, *Flavins and Flavoproteins 2005*: 341–346
- Calzi, M. L., and Pool, L.B., 1997, Requirement for the two AhpF cysteine disulfide centers in catalysis of peroxide reduction of alkyl hydroperoxide reductase protein. *Biochemistry*. **36**: 13357–13364.
- Jacobson, F. S., Morgan, R. W., Christman, M. F., and Ames, B. N., 1989, An alkyl hydroperoxide reductase from *Salmonella typhimurium* involved in the defense of DNA against oxidative damage. *J. Biol. Chem.* **264**: 1488–1496.
- Kitano, K., Niimura, Y., Nishiyama, Y., Miki, K., 1999, Stimulation of Peroxidase activity by decamerization related to ionic strength: AhpC protein from *Amphibacillus xylanus*, *J. Biochem.* **126**: 313–319.
- Kitano, K., Kita, A., Hakoshima, T., Niimura, Y., Miki, K., 2005, Crystal Structure of Decameric Peroxiredoxin (AhpC) from *Amphibacillus xylanus*. *Proteins* **59**: 644–647
- Koyama, N., Koitabashi, T., Niimura, Y., and Massey, V., 1998, Peroxide reductase activity of NADH dehydrogenase of an alkaliphilic *Bacillus* in the presence of a 22-kDa protein component from *Amphibacillus xylanus*., *Biochem. Biophys. Res. Commun.* **247**: 659–662.
- Kozaki, M., Iino, H., Anzai, Y., and Niimura, Y., 1996, Aerobic metabolism of glucose by facultative anaerobe *Sporolactobacillus inulinus*. *Bulletin of The Doctoral Course of Science for Living System Showa Women's University*, **5**: 33–41.
- Niimura, Y., Yanagida, F., Uchimura, T., Ohara, N., Suzuki, K., and Kozaki, M., 1987, A new facultative anaerobic xylan-using alkalophile lacking cytochrome, quinone, and catalase. *Agric. Biol. Chem.* **51**: 2271–2275.
- Niimura, Y., Koh, E., Uchimura, T., Chara, N., and Kozaki, M., 1989, Aerobic and anaerobic metabolism in a facultative anaerobe Ep01 lacking cytochrome, quinone and catalase. *FEMS Microbiol. Lett.* **61**: 79–84.
- Niimura, Y., Yanagida, F., Suzuki, K., Komagata, K., and Kozaki, M., 1990, *Amphibacillus xylanus* gen. nov., sp. nov., a facultatively anaerobic sporeforming xylan-digesting bacterium which lacks cytochrome, quinone, and catalase. *Int. J. Syst. Bacteriol.* **40**: 297–301.
- Niimura, Y., Ohnishi, K., Yarita, Y., Hidaka, M., Masaki, H., Uchimura, T., Suzuki, H., and Kozaki, M., 1993, A flavoprotein functional as NADH oxidase from *Amphibacillus xylanus* Ep01: purification and characterization of the enzyme and structural analysis of its gene. *J. Bacteriol.* **175**: 7945–7950.
- Niimura, Y., Yokoyama, K., Ohnishi, K., and Massey, V., 1994, A flavoprotein functional as NADH oxidase from *Amphibacillus xylanus* scavenges hydrogen peroxide in the presence of free FAD. *Biosci. Biotech. Biochem.*, **58**: 2310–2311.
- Niimura, Y., Poole, L. B., and Massey, V., 1995, *Amphibacillus xylanus* NADH oxidase and *Salmonella typhimurium* alkyl-hydroperoxide reductase flavoprotein components show extremely high scavenging activity for both alkyl hydroperoxide and hydrogen peroxide in the presence of *S. typhimurium* alkyl hydroperoxide reductase 22-kDa protein component. *J. Biol. Chem.* **270**: 25645–25650.
- Niimura, Y. and Massey, V., 1996, Reaction mechanism of *Amphibacillus xylanus* NADH oxidase/alkyl hydroperoxide reductase flavoprotein. *J. Biol. Chem.* **271**: 30459–30464.

- Niimura, Y., Nishiyama, Y., Takeda, K., Tsuji, H., Ohnishi, K., Watanabe, T., Nishino, T., and Massey, V., 1999. An NADH oxidase functional as alkyl hydroperoxide reductase. *Flavins and Flavoproteins 1999* : 677–680.
- Niimura, Y., Nishiyama, Y., Saito, D., Tsuji, H., Hidaka, M., Miyaji, T., Watanabe, T., and Massey, V., 2000. A hydrogen peroxide-forming NADH oxidase that functions as an alkyl hydroperoxide reductase in *Amphibacillus xylanus*. *J. Bacteriol.* **182**: 5046–5051.
- Nishiyama, Y., Massey, V., Anzai, Y., Watanabe, T., Miyaji, T., Uchimura, T., Kozaki, M., Suzuki, H., and Niimura, Y., 1997., Purification and characterization of *Sporolactobacillus inulinus* NADH oxidase and its physiological role in aerobic metabolism of the bacterium. *J. Ferment. Bioeng.* **84**: 22–27.
- Nishiyama, Y., Massey, V., Takeda, K., Kawasaki, S., Sato, J., Watanabe, T., and Niimura, Y., 2001. Hydrogen peroxide-forming NADH oxidase belonging to the peroxiredoxin oxidoreductase family: existence and physiological role in bacteria. *J. Bacteriol.* **183**: 2431–2438.
- Ohnishi, K., Niimura, Y., Yokoyama, K., Hidaka, M., Masaki, H., Uchimura, T., Suzuki, H., Uozumi, T., Kozaki, M., Komagata, K., and Nishino, T., 1994, Purification and analysis of a flavoprotein functional as NADH oxidase from *Amphibacillus xylanus* overexpressed in *Escherichia coli*. *J. Biol. Chem.* **269**: 31418–31423.
- Ohnishi, K., Niimura, Y., Hidaka, M., Masaki, H., Suzuki, H., Uozumi, T., and Nishino, T., 1995, Role of cysteine 337 and cysteine 340 in flavoprotein that functions as NADH oxidase from *Amphibacillus xylanus* studied by site-directed mutagenesis. *J. Biol. Chem.* **270**: 5812–5817.
- Poole, L.B., Reynolds, C. M., Wood, Z. A., Karplus, P. A., Ellis, H. R., and Calzi, M. L., 2000a, AhpF and other NADH: peroxiredoxin oxidoreductases, homologues of low  $M_r$  thioredoxin reductase. *Eur. J. Biochem.* **267**: 6126–6133.
- Poole, L.B., Higuchi, M., Shimada, M., Calzi, M. L., and Kamio, Y., 2000b, *Streptococcus mutans* H<sub>2</sub>O<sub>2</sub>-forming NADH oxidase is an alkyl hydroperoxide reductase protein. *Free Radic. Biol. Med.* **28**: 108–120.
- Wood, Z. A., Poole, L.B., Hantgan, R. R., and Karplus, P. A., 2002, Dimers to doughnuts: redox-sensitive oligomerization of 2-cysteine peroxiredoxins. *Biochemistry* **41**: 5493–5504.
- Seaver, L. C., and Imlay, J. A., 2001, Alkyl hydroperoxide reductase is primary scavenger of endogenous hydrogen peroxide in *Escherichia coli*. *J. Bacteriol.* **183**: 7173–7181.
- Takeda, K., Kawasaki, S., Niimura, Y., Nishiyama, Y., and Massey, V., 2002, NADH oxidase concerned in hydro peroxide scavenging system. Reaction mechanism and Physiological Role in Microorganisms. *Flavins and Flavoproteins 2002*: 393–398.

## CHAPTER 9

# PEROXIREDOXIN SYSTEMS IN MYCOBACTERIA

TIMO JAEGER

*MOLISA GmbH, Molecular Links Sachsen-Anhalt, Universitaetsplatz 2, D-39106 Magdeburg, Germany*

**Abstract:** Like other actinomycetes *Mycobacterium tuberculosis* lacks glutathione and, consequently, the glutathione peroxidases that dominate the antioxidant defence of its mammalian hosts. The hydrogen peroxide metabolism of the pathogen has for long been recognised to depend on a heme-containing catalase/peroxidase. Clinical isolates lacking the catalase were virulent and proved to be resistant to the first line tuberculostatic isoniazid, because the enzyme is evidently required to activate this drug. The survival and virulence of such strains are attributed to the peroxiredoxin-type peroxidases alkyl hydroperoxide reductase (AhpC) and thioredoxin peroxidase (TPx). The most common AhpC reductant in bacteria, the disulfide reductase AhpF, is deleted in *M. tuberculosis*. Instead, AhpC can be reduced by AhpD, a CXXC-motif-containing protein, or by one of the mycobacterial thioredoxins, TrxC. TPx is reduced by thioredoxins B and C. Mycobacteria contain three more peroxiredoxins, the 1-Cys-Prx AhpE, Bcp and BcpB, whose function and reductants are still unknown

**Keywords:** Oxidative stress, Peroxidase, Thioredoxin, Peroxiredoxin, tuberculosis, *Mycobacterium*, Drug development

### 1. INTRODUCTION

*Mycobacterium tuberculosis* is a devastating human pathogen, responsible for around three million deaths worldwide every year (Dye *et al.*, 1999). Its success as a pathogen is attributable in part to its ability to enter a dormant or persistent state inside activated macrophages in the lung (McKinney *et al.*, 2000; Parrish *et al.*, 1998). Engulfment of the organism by macrophages is associated both with exposure to the toxic environment within the macrophage phagosome and with the onset of conditions where essential nutrients, including oxygen, are in very low supply. In these conditions, the enzymes and small-molecule reducing agents that protect *M. tuberculosis* against peroxides and other reactive oxygen species (ROS) become very important to its survival (Manca, *et al.*, 1999). Antioxidant defence in *M. tuberculosis* is unusual in many respects. Among the defences of



*M. tuberculosis* against ROS are the low molecular mass thiol compound, mycothiol, which substitutes in mycobacteria for glutathione (GSH) (Newton and Fahey, 2002), the catalase/peroxidase enzyme, KatG (Manca, *et al.*, 1999), and a variety of thioredoxin-related enzymes (Jaeger, *et al.*, 2004). Mutations of KatG provide resistance to the frontline TB drug isoniazid, which requires activation by KatG (Zhang *et al.*, 1992). The deficiency in KatG in such strains, however, appears to be compensated by overexpression of other components of the protective response, notably the alkyl hydroperoxide reductase AhpC (Sherman *et al.*, 1996), a member of the Prx family (Hofmann, *et al.*, 2002; Wood, *et al.*, 2003). In bacteria, Prxs can detoxify deleterious ROS, such as H<sub>2</sub>O<sub>2</sub> and alkyl hydroperoxides as well as reactive nitrogen species such as peroxyntirite (Bryk, *et al.*, 2000; Jaeger, *et al.*, 2004). The activity of *M. tuberculosis* AhpC against a broad range of such substrates thus explains its ability to substitute for the loss of catalase/peroxidase activity in *M. tuberculosis* KatG mutants (Sherman *et al.*, 1996). A second peroxiredoxin system, the thioredoxin peroxidase (TPx) system, appears to play the leading role in hydroperoxide and peroxyntirite detoxification in *M. tuberculosis*, independent of isoniazid susceptibility (Jaeger, *et al.*, 2004; Trujillo, *et al.*, 2006). All together, the *M. tuberculosis* genome sequence has shown the presence of at least five Prxs, namely bacterioferritin comigrating proteins (Bcp and BcpB), AhpE, TPx and AhpC (Cole, *et al.*, 1998). Three of these belong to the 1-Cys-Prx class, and two of them, TPx and AhpC, appear to belong to the 2-Cys-Prx class.

## 2. MYCOBACTERIAL PEROXIREDOXINS

### 2.1. Alkyl Hydroperoxide Reductase (AhpC)

AhpC has sequence homology to the two cysteine containing AhpC proteins from other organisms and seems to belong to the typical 2-Cys-Prx. It has a higher similarity to the Gram-positive (*Corynebacterium diphtheriae*, *Streptomyces viridosporus*) than to the Gram-negative (*Escherichia coli*, *Salmonella typhimurium*, *Bacillus subtilis*, and *Staphylococcus aureus*) AhpC proteins. Although *MtAhpC* is usually considered a typical 2-Cys peroxiredoxin, it differs in a number of important features from other members of the family.

First, *MtAhpC* has three (rather than two) cysteine residues directly involved in catalysis (Chauhan and Mande, 2002), the conserved peroxidatic cysteine Cys61, the putative resolving cysteine Cys174, and a third cysteine, Cys176, whose catalytic role is unclear (Chauhan and Mande, 2002; Koshkin *et al.*, 2004). The functional dimer of *MtAhpC* C176S has a structure similar to those of other 2-C-Prx (Guimaraes, *et al.*, 2005). However, although the oxidised protein behaves as a dimer in solution, it crystallised in an oligomeric (12-mer) form resembling the decameric forms observed for other peroxiredoxins (Hofmann, *et al.*, 2002; Wood, *et al.*, 2003). In agreement with available mutagenesis data (Chauhan and Mande, 2002), the structure suggests a model for the peroxidase reaction that can explain the involvement of the three cysteine residues in catalysis. To facilitate the formation

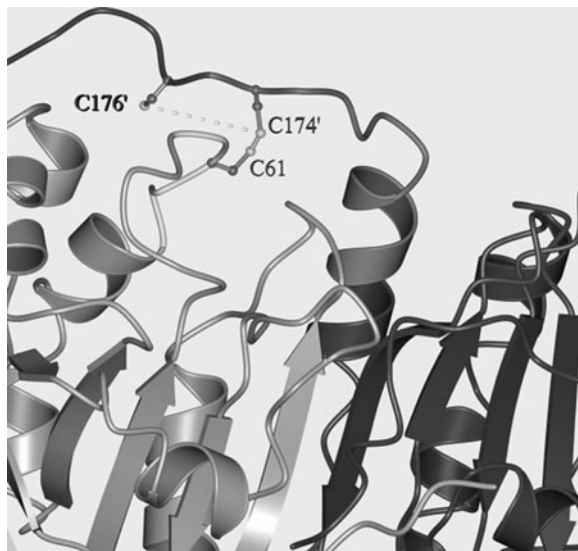

Figure 1. Model of oxidised *MtAhpC* according to Guimaraes, *et al.* (2005). A rigid-body movement allows the peroxidatic cysteine C61 to be in contact with the resolving cysteine C174 of another subunit

of the Cys61 – Cys174 disulfide bond (Fig. 1), the entire  $\alpha$ -helix containing the peroxidatic cysteine is seen to undergo a rigid-body displacement instead of the partial helical unwinding observed in the disulfide-bonded forms of other 2-Cys-Prx (Guimaraes, *et al.*, 2005; Wood, *et al.*, 2003). This unusual movement generates a large internal cavity, which encloses the reaction centre.

Second, for a long time it remained an enigma how *MtAhpC* is supplied with reduction equivalents, because in the mycobacterial genome there is no homologue of the AhpF flavoprotein known to reduce AhpC in *S. typhimurium* (Ellis and Poole, 1997). Instead, *MtAhpC* is reduced by the thioredoxin system involving thioredoxin C (TrxC) and thioredoxin reductase (TrxR) (Jaeger, *et al.*, 2004). Additionally, a quite unique system of AhpC reduction has been reported, consisting of a CXXC motif-containing protein, AhpD, dihydrolipoamide succinyltransferase and dihydrolipoamide dehydrogenase (Bryk *et al.*, 2002) (Fig. 2). Steady-state kinetic analysis yielded a net forward rate constant of *MtAhpC* for the reaction with *tert*-butyl hydroperoxide,  $k_1'$ , of  $1 \times 10^4 \text{ M}^{-1}\text{s}^{-1}$ , which marks the lower edge of corresponding peroxiredoxin constants (Hofmann, *et al.*, 2002; Jaeger, *et al.*, 2004, Wood, *et al.*, 2003; see also Chapter 5 by Trujillo *et al.*). For the reduction of *MtAhpC* by *MtAhpD*, a  $k_2'$  of  $2.7 \times 10^6 \text{ M}^{-1}\text{s}^{-1}$  was obtained. The kinetic analysis of *MtAhpC* in the system reconstituted by homologous TrxR and TrxC yielded a  $k_1'$  of  $2.3 \times 10^4 \text{ M}^{-1}\text{s}^{-1}$  that is nearly identical to that obtained in the *MtAhpD* system. Both the  $k_2'$  and the  $K_M$  characterising the reactivity and/or affinity to TrxC compare unfavourably with the constants for *MtAhpD* by a factor of 10 and 20, respectively,

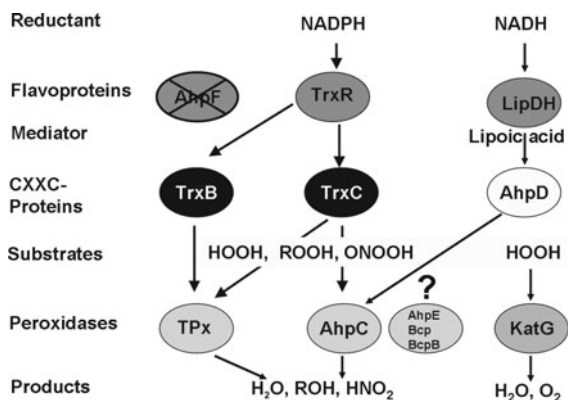

Figure 2. Hydroperoxide metabolism in mycobacteria. Homologous proteins are shown in identically marked circles

yet the relative cellular abundancies of the potential *MtAhpC* reductants qualify *MtTrxC* as a relevant one (Jaeger, *et al.*, 2004).

In mycobacteria, AhpC can not only detoxify hydroperoxides but also affords protection to cells against reactive nitrogen intermediates (Chen *et al.*, 1998; Master *et al.*, 2002). *MtAhpC* specifically catalyses the conversion of peroxyntirite ( $\text{OONO}^-$ ) to nitrite fast enough to avoid the spontaneous decomposition of the former into the deleterious nitrogen dioxide and hydroxyl radicals. The  $k_1'$  value of *MtAhpC* for peroxyntirite was reported to be  $1.33 \times 10^6 \text{ M}^{-1} \text{ s}^{-1}$  (Bryk, *et al.*, 2000). The NADPH-dependent peroxidase and peroxyntirite reductase system of *M. tuberculosis* thus involves *MtAhpC* as the foremost element of a chain that includes the *MtAhpC*-reducing protein, thioredoxin C (TrxC), and thioredoxin reductase (TrxR) (Jaeger, *et al.*, 2004).

## 2.2. Thioredoxin Peroxidase (TPx)

The second mycobacterial peroxidase, TPx, has been characterised as the most effective peroxidase of *M. tuberculosis* in terms of rate constants for the reaction with hydroperoxides and peroxyntirite. It reduces a broad spectrum of hydroperoxides, including  $\text{H}_2\text{O}_2$ , and its reduced state is specifically regenerated by two of the mycobacterial thioredoxins, *MtTrxB* and *MtTrxC* (Jaeger, *et al.*, 2004) (Fig. 2). According to available proteomes of *M. tuberculosis* (Mollenkopf *et al.*, 1999), *MtTPx* is regularly more abundant than the better known antioxidant enzymes catalase/peroxidase and AhpC and may therefore be considered to be the dominant antioxidant device that guarantees the survival of the pathogen in the oxidant environment of the phagocytes of the host.

Homologues of *MtTPx* are distributed throughout most or all Gram-positive and Gram-negative bacteria but biochemical and structural analyses have been limited primarily to *E. coli* (Baker and Poole, 2003, Cha *et al.*, 2004; Choi *et al.*,

2003), *Streptococcus pneumoniae* (PDB 1psq, 2003), and *Haemophilus influenzae* (PDB 1q98, 2003). By sequence, *MtTPx* is classified as an atypical 2-C-Prx. TPx homologues typically contain three cysteine residues, Cys93, Cys80, and Cys60 in *MtTPx*, and the latter residue aligns with the N-terminal active site Cys of other peroxidases in the Prx family. The X-ray structures of *MtTPx* (Rho, *et al.*, 2006), of the inactive mutant *MtTPx* C60S (Stehr, *et al.*, 2006), and of the related Prx of *H. influenzae*, *E. coli* and *S. pneumoniae* reveal that Cys60 in *MtTPx* builds up the centre of the catalytic triad typical for of Prx, which here is composed of Cys60, Thr57, and Arg130. Cys60 thus should be the peroxidatic cysteine, whereas Cys93 is homologous to the presumed C<sub>R</sub> of related atypical 2-Cys-Prx, and the third cysteine in *MtTPx*, Cys80, remains of questionable functional relevance. Recently a novel variation of Prx catalysis was reported for *MtTPx*. Neither Cys80 nor Cys93 is required for the catalytic cycle of the peroxidase. Instead, *MtTPx* can react as a 1-Cys-Prx with Cys60 being the site of attack for both the oxidising and the reducing substrate. The role of Cys93 is likely to conserve the oxidation equivalents of the sulfenic acid state of C<sub>p</sub> as a disulfide bond to prevent overoxidation of Cys60 under a restricted supply of reducing substrate (Trujillo, *et al.*, 2006) (Fig. 3).

Like *MtAhpC*, *MtTPx* is reduced by *MtTrxC* and accepts also *MtTrxB* although with slightly lower reactivity. The peroxidatic efficiency of *MtTPx* is about one order of magnitude higher than that of *MtAhpC*. With *MtTrxB* as co-substrate and *tert*-butyl hydroperoxide as oxidant, a  $k_1'$  value  $3.3 \times 10^5 \text{ M}^{-1} \text{ s}^{-1}$  was measured (Jaeger, *et al.*, 2004). The  $k_2$  values of *MtTPx* for both thioredoxins are slightly

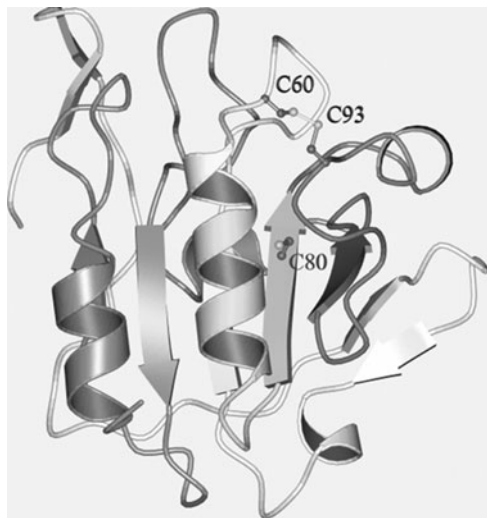

*Figure 3.* Three-dimensional structure of oxidised *MtTPx*. C60 builds the centre of the catalytic triad typical of Prx. C60 thus should be the peroxidatic cysteine, whereas the role of C93 is likely to conserve the oxidation equivalents of the sulfenic acid state of C<sub>p</sub> as a disulfide bond to prevent overoxidation of C61

higher than that of *MtAhpC* for *MtTrxC*. The highest  $V_{\max}$  is obtained for the *MtTPx/MtTrxC* system. *MtTPx* also reduces peroxyxynitrite, which is formed by activated macrophages from  $\cdot\text{O}_2^-$  and  $\cdot\text{NO}$  (Alvarez *et al.*, 2002) and participates in the nitric oxide-dependent killing of *M. tuberculosis* (St John *et al.*, 2001). The rate constant for *MtTPx*/peroxyxynitrite interaction is  $1.5 \times 10^7 \text{ M}^{-1}\text{s}^{-1}$  and thus ranges amongst the highest so far observed for peroxidases working with sulfur catalysis (Jaeger, *et al.*, 2004; see also Chapter 5).

### 2.3. Other Peroxiredoxins in Mycobacteria

The elucidation of the complete genome sequence of *M. tuberculosis* (Cole, *et al.*, 1998) has led to the discovery of further genes whose gene products belong to the Prx family. In addition to *ahpC* (Rv2428) and *tpx* (Rv1932), open reading frames can be found encoding other related proteins. These include Rv2238c, annotated as *ahpE*, Rv1608c (*bcpB*) and Rv2521 (*bcp*), all with putative roles in the detoxification of ROS. The crystal structure of AhpE has been determined recently (Li *et al.*, 2005). But how these redox-active compounds are integrated in the mycobacterial antioxidant defence awaits clarification.

## 3. REDUCTION OF THIOREDOXINS

Trx, TrxR and NADPH constitute the well known thioredoxin system that is responsible for maintaining reducing conditions inside the cell (Arner and Holmgren, 2000). The other major system required for maintaining intracellular reducing conditions, namely the glutathione system, consisting of glutathione, glutaredoxin, glutathione reductase and NADPH (Flohé and Brigelius-Flohé, 2001) is missing in mycobacteria. A crucial member of the thioredoxin system, TrxR, is a member of the family of dimeric pyridine nucleotide-disulfide oxidoreductase flavoproteins that catalyse the transfer of electrons between pyridine nucleotide and disulfide/dithiol compounds and promote catalysis *via* FAD and a redox-active disulfide. This family of oxidoreductases includes glutathione reductase, lipoamide dehydrogenase, mercuric reductase, AhpF and trypanothione reductase (Williams, *et al.*, 2000). TrxR catalyses the reduction of Trx by NADPH. The thioredoxin system is present in all prokaryotic and eukaryotic cells studied so far and operates via thiol/disulfide exchange reactions, thereby providing electrons for different metabolic processes (Gromer, *et al.*, 2004). The thioredoxins, typically ubiquitous 12 kDa proteins with a CGPC motif, in the dithiol form, are the major disulfide reductases in cells (Williams, *et al.*, 2000). Regeneration of the vicinal thiols of Trxs is almost regularly achieved by interaction with thiols or selenols of a TrxR. Two distinct classes of TrxRs exist in nature. The high-molecular-weight type occurs in mammals, *Drosophila melanogaster*, *Caenorhabditis elegans* and *Plasmodium falciparum*, whereas plants, fungi and bacteria contain a low-molecular-weight type of TrxR (Gromer, *et al.*, 2004). In mammals, TrxR interacts with Trx via a Cys-Sec motif that is located in the flexible C-terminus and is required to transfer the reduction

equivalents from the central redox centre to the substrate. In contrast, the central thiols of bacterial TrxR have to interact directly with the thioredoxins.

The genome of *M. tuberculosis* contains a single copy of just one thioredoxin reductase gene. The TrxR of *M. tuberculosis*, like that of *E. coli*, is a low-molecular-weight dimeric protein containing FAD- and NADPH-binding domains in each subunit. It shares more than 45 % sequence identity with *E. coli* TrxR. In contrast to mammalian TrxRs, which reduce a bewildering variety of structurally diverse compounds (Björnstedt *et al.*, 1995, Zhong and Holmgren, 2002) *Mt*TrxR is specific for *Mt*TrxB and *Mt*TrxC, while other CXXC proteins and even *Mt*TrxA are not readily reduced by *Mt*TrxR (Jaeger, *et al.*, 2004) (Fig. 2). This discrepancy is likely explained by the necessity of the direct interaction of the Trxs with the central redox centres in *Mt*TrxR, while the flexible C-terminus of mammalian TrxR with its highly reactive Cys-Sec motif promiscuously attacks all kind of disulfides, quinones and other oxidants.

#### 4. POTENTIAL IMPACT FOR DRUG DISCOVERY

The complete genome sequencing of *M. tuberculosis* has been a landmark in mycobacterial research (Cole, *et al.*, 1998) with opens up most attractive perspectives for novel therapeutic interventions. The validation of drug targets, however, is only in slow progress and the genetic determinants of *M. tuberculosis* virulence are not yet completely understood (Smith, 2003). Nevertheless, the mycobacterial genome complemented by proteomes and functional studies disclosed some unique features of the antioxidant defence system in mycobacteria that allow certain important predictions: *i*) The glutathione system is indeed totally absent in *M. tuberculosis*. *ii*) Apart from the heme-containing catalase/peroxidase only peroxiredoxin-type peroxidases are detected, of which so far, *iii*) *Mt*AhpC and *Mt*TPx have been characterised as efficient Trx-dependent reductases of H<sub>2</sub>O<sub>2</sub>, organic hydroperoxides and peroxytrite. *iv*) Among the mycobacterial Trxs TrxC is the most abundant and an efficient one in reducing both, *Mt*AhpC and *Mt*TPx. *v*) *M. tuberculosis* possesses only one TrxR, and *vi*) this belongs to the specific bacterial subfamily of TrxRs.

Clearly, hydroperoxide metabolism in *M. tuberculosis* differs substantially from that in the mammalian hosts and thus the chances for a selective inhibition of the mycobacterial antioxidant defence system may be rated as excellent. Such selective disruption of the defence system would certainly impair the viability of the pathogen, since the efficacy of the host's innate immune response would inevitably be enhanced. This concept has attracted considerable interest (Friemann *et al.*, 2003) and has been validated by inverse genetics for other pathogens that lack the glutathione system such as *Trypanosoma* and *Leishmania* species (Comini *et al.*, 2004, Krauth-Siegel and Inhoff, 2003). Selective inhibitors of the mycobacterial hydroperoxide metabolism are therefore expected to become auxiliary or stand-alone drugs to treat tuberculosis.

It remains to be discussed how the required selectivity and reliability will be best achieved. Fortunately, the functional and structural knowledge of all system components is growing at a pace that, in principle, makes the design of specific inhibitors a realistic prospect. These insights also reveal which of the possible routes of intervention can be considered promising or rather dead-end roads:

- i) Selective inhibition of one of the mycobacterial Prxs appears to be a risky strategy; the clinical experience with the KatG-negative strains teaches that any particular peroxidase deficiency is easily compensated in *M. tuberculosis* by overexpression of another one (Sherman *et al.*, 1996).
- ii) An inhibition of all relevant Prxs appears impossible without simultaneously affecting the homologous host enzymes, since the structures of *MtAhpC* (Guimaraes, *et al.*, 2005) and *MtTPx* (Rho, *et al.*, 2006, Stehr, *et al.*, 2006) are more diverse than those of AhpC and the typical human 2-Cys-Prxs or those of *MtTPx* and human PrxV, respectively. Any less selective Prx inhibitor would likely hit the human congeners with unpredictable consequences.
- iii) The realm of established Trx structures reveals that their active sites are as similar as their overall folding patterns. A selective inhibition of the pathogen's Trxs therefore appears to be extremely difficult, but would be mandatory, since Trx is essential in mammals (Matsui *et al.*, 1996).
- iv) Moreover, none of the known Trx structures displays a characteristic binding pocket for a substrate. Trxs may therefore be rated as hardly "drugable" in general.
- v) Although TrxR of *M. tuberculosis* has not been validated as a drug target according to state-of-the-art protocols, it may safely be predicted to be as essential as its mammalian congeners (Conrad *et al.*, 2004; Jakupoglu *et al.*, 2005) in view of its role in the reduction of Trx, which is not only pivotal to hydroperoxide metabolism but also to ribonucleotide reduction and many other processes. Moreover, since a compensating substitute of TrxR is not envisaged in *M. tuberculosis*, inhibition of *MtTrxR* should not only efficiently but also reliably, *i. e.* with minimum risk of resistance development, impair the viability and virulence of the pathogen.
- vi) The substantial differences in sequences, mechanisms and structures between human TrxRs and the mycobacterial type (Akif *et al.*, 2005) render selective inhibition possible.

In short, therefore, a therapeutic interference with the mycobacterial antioxidant defence system should target the most upstream valve of the entire redox cascade, the *MtTrxR*, if reliable efficacy, adequate safety, and lack of resistance development is intended.

## REFERENCES

- Akif, M., Suhre, K., Verma, C., Mande, S.C., 2005, Conformational flexibility of *Mycobacterium tuberculosis* thioredoxin reductase: crystal structure and normal-mode analysis. *Acta Crystallogr. D Biol. Crystallogr.* **61**: 1603–1611.

- Alvarez, M.N., Trujillo, M., Radi, R., 2002, Peroxynitrite formation from biochemical and cellular fluxes of nitric oxide and superoxide. *Methods Enzymol.* **359**: 353–366.
- Arner, E.S., Holmgren, A., 2000, Physiological functions of thioredoxin and thioredoxin reductase. *Eur. J. Biochem.* **267**: 6102–6109.
- Baker, L.M., Poole, L.B., 2003, Catalytic mechanism of thiol peroxidase from *Escherichia coli*. Sulfenic acid formation and overoxidation of essential CYS61. *J. Biol. Chem.* **278**: 9203–9211.
- Björnstedt, M., Kumar, S., Holmgren, A., 1995, Selenite and selenodiglutathione: reactions with thioredoxin systems. *Methods Enzymol.* **252**: 209–219.
- Bryk, R., Griffin, P., Nathan, C., 2000, Peroxynitrite reductase activity of bacterial peroxiredoxins. *Nature* **407**: 211–215.
- Bryk, R., Lima, C.D., Erdjument-Bromage, H., Tempst, P., Nathan, C., 2002, Metabolic enzymes of mycobacteria linked to antioxidant defense by a thioredoxin-like protein. *Science* **295**: 1073–1077.
- Cha, M.K., Kim, W.C., Lim, C.J., Kim, K., Kim, I.H., 2004, *Escherichia coli* periplasmic thiol peroxidase acts as lipid hydroperoxide peroxidase and the principal antioxidative function during anaerobic growth. *J. Biol. Chem.* **279**: 8769–8778.
- Chauhan, R., Mande, S. C., 2002, Site-directed mutagenesis reveals a novel catalytic mechanism of *Mycobacterium tuberculosis* alkylhydroperoxidase C. *Biochem. J.* **367**: 255–261.
- Chen, L., Xie, Q.W., Nathan, C., 1998, Alkyl hydroperoxide reductase subunit C (AhpC) protects bacterial and human cells against reactive nitrogen intermediates. *Mol. Cell* **1**: 795–805.
- Choi, J., Choi, S., Choi, J., Cha, M.K., Kim, I.H., Shin, W., 2003, Crystal structure of *Escherichia coli* thiol peroxidase in the oxidized state: insights into intramolecular disulfide formation and substrate binding in atypical 2-Cys peroxiredoxins. *J. Biol. Chem.* **278**: 49478–49486.
- Cole, S.T., Brosch, R., Parkhill, J., Garnier, T., Churcher, C., Harris, D., Gordon, S.V., Eiglmeier, K., Gas, S., Barry, C.E., 3rd, Tekaiia, F., Badcock, K., Basham, D., Brown, D., Chillingworth, T., Connor, R., Davies, R., Devlin, K., Feltwell, T., Gentles, S., Hamlin, N., Holroyd, S., Hornsby, T., Jagels, K., Krogh, A., McLean, J., Moule, S., Murphy, L., Oliver, K., Osborne, J., Quail, M.A., Rajandream, M. A., Rogers, J., Rutter, S., Seeger, K., Skelton, J., Squares, R., Squares, S., Sulston, J. E., Taylor, K., Whitehead, S., Barrell, B.G., 1998, Deciphering the biology of *Mycobacterium tuberculosis* from the complete genome sequence. *Nature* **393**: 537–544.
- Comini, M.A., Guerrero, S.A., Haile, S., Menge, U., Lünsdorf, H., Flohé, L., 2004, Valdiation of *Trypanosoma brucei* trypanothione synthetase as drug target. *Free Radic. Biol. Med.* **36**: 1289–1302.
- Conrad, M., Jakupoglu, C., Moreno, S.G., Lippl, S., Banjac, A., Schneider, M., Beck, H., Hatzopoulos, A.K., Just, U., Sinowatz, F., Schmahl, W., Chien, K.R., Wurst, W., Bornkamm, G.W., Brielmeier, M., 2004, Essential role for mitochondrial thioredoxin reductase in hematopoiesis, heart development, and heart function. *Mol. Cell. Biol.* **24**: 9414–9423.
- Dye, C., Scheele, S., Dolin, P., Pathania, V., Ravigione, M.C., 1999, Consensus statement. Global burden of tuberculosis: estimated incidence, prevalence, and mortality by country. WHO Global Surveillance and Monitoring Project. *JAMA* **282**: 677–686.
- Ellis, H.R., Poole, L. B., 1997, Roles for the two cysteine residues of AhpC in catalysis of peroxide reduction by alkyl hydroperoxide reductase from *Salmonella typhimurium*. *Biochemistry* **36**: 13349–13356.
- Flohé, L., Brigelius-Flohé, R. Selenoproteins of the glutathione system. In: D. L. Hatfield, ed. Selenium. Its Molecular Biology and Role in Human Health, London: Kluwer Academic Publishers; 2001: 157–178.
- Friemann, R., Schmidt, H., Ramaswamy, S., Forstner, M., Krauth-Siegel, R.L., Eklund, H., 2003, Structure of thioredoxin from *Trypanosoma brucei brucei*. *FEBS Lett.* **554**:3 01–305.
- Gromer, S., Urig, S., Becker, K., 2004, The thioredoxin system—from science to clinic. *Med. Res. Rev.* **24**: 40–89.
- Guimaraes, B.G., Souchon, H., Honore, N., Saint-Joanis, B., Brosch, R., Shepard, W., Cole, S.T., Alzari, P.M., 2005, Structure and mechanism of the alkyl hydroperoxidase AhpC, a key element of the *Mycobacterium tuberculosis* defense system against oxidative stress. *J. Biol. Chem.* **280**: 25735–25742.
- Hofmann, B., Hecht, H.J., Flohé, L., 2002, Peroxiredoxins, *Biol. Chem.* **383**:347–364.



- Jaeger, T., Budde, H., Flohé, L., Menge, U., Singh, M., Trujillo, M., Radi, R., 2004, Multiple thioredoxin-mediated routes to detoxify hydroperoxides in *Mycobacterium tuberculosis*. *Arch. Biochem. Biophys.* **423**: 182–191.
- Jakupoglu, C., Przemeczek, G.K., Schneider, M., Moreno, S.G., Mayr, N., Hatzopoulos, A.K., de Angelis, M.H., Wurst, W., Bornkamm, G.W., Brielmeier, M., Conrad, M., 2005, Cytoplasmic thioredoxin reductase is essential for embryogenesis but dispensable for cardiac development. *Mol. Cell. Biol.* **25**: 1980–1988.
- Koshkin, A., Knudsen, G.M., Ortiz De Montellano, P.R., 2004, Intermolecular interactions in the AhpC/AhpD antioxidant defense system of *Mycobacterium tuberculosis*. *Arch. Biochem. Biophys.* **427**: 41–47.
- Krauth-Siegel, R.L., Inhoff, O., 2003, Parasite-specific trypanothione reductase as a drug target molecule. *Parasitol. Res.* **90**: S77–85.
- Li, S., Peterson, N.A., Kim, M.Y., Kim, C.Y., Hung, L.W., Yu, M., Legin, T., Segelke, B.W., Lott, J.S., Baker, E.N., 2005, Crystal Structure of AhpE from *Mycobacterium tuberculosis*, a 1-Cys peroxiredoxin. *J. Mol. Biol.* **346**: 1035–1046.
- Manca, C., Paul, S., Barry, C.E., 3rd, Freedman, V.H., Kaplan, G., 1999, *Mycobacterium tuberculosis* catalase and peroxidase activities and resistance to oxidative killing in human monocytes in vitro. *Infect. Immun.* **67**: 74–79.
- Master, S.S., Springer, B., Sander, P., Boettger, E.C., Deretic, V., Timmins, G.S., 2002, Oxidative stress response genes in *Mycobacterium tuberculosis*: role of ahpC in resistance to peroxynitrite and stage-specific survival in macrophages. *Microbiology* **148**: 3139–3144.
- Matsui, M., Oshima, M., Oshima, H., Takaku, K., Maruyama, T., Yodoi, J., Taketo, M. M., 1996, Early embryonic lethality caused by targeted disruption of the mouse thioredoxin gene. *Dev. Biol.* **178**: 179–185.
- McKinney, J.D., Honer zu Bentrup, K., Munoz-Elias, E. J., Miczak, A., Chen, B., Chan, W. T., Swenson, D., Sacchettini, J.C., Jacobs, W.R., Jr., Russell, D.G., 2000, Persistence of *Mycobacterium tuberculosis* in macrophages and mice requires the glyoxylate shunt enzyme isocitrate lyase. *Nature* **406**: 735–738.
- Mollenkopf, H.J., Jungblut, P.R., Raupach, B., Mattow, J., Lamer, S., Zimny-Arndt, U., Schaible, U.E., Kaufmann, S.H., 1999, A dynamic two-dimensional polyacrylamide gel electrophoresis database: the mycobacterial proteome via Internet. *Electrophoresis* **20**: 2172–2180.
- Newton, G.L., Fahey, R.C., 2002, Mycothiol biochemistry. *Arch. Microbiol.* **178**: 388–394.
- Parrish, N.M., Dick, J.D., Bishai, W.R., 1998, Mechanisms of latency in *Mycobacterium tuberculosis*. *Trends Microbiol.* **6**: 107–112.
- Rho, B.S., Hung, L.W., Holton, J.M., Vigil, D., Kim, S.I., Park, M.S., Terwilliger, T.C., Pedelacq, J.D., 2006, Functional and structural characterization of a thiol peroxidase from *Mycobacterium tuberculosis*. *J. Mol. Biol.* **361**: 850–863.
- Sherman, D.R., Mdluli, K., Hickey, M.J., Arain, T.M., Morris, S.L., Barry, C.E., 3rd, Stover, C.K., 1996, Compensatory ahpC gene expression in isoniazid-resistant *Mycobacterium tuberculosis*. *Science* **272**: 1641–1643.
- Smith, I., 2003, *Mycobacterium tuberculosis* pathogenesis and molecular determinants of virulence. *Clin. Microbiol. Rev.* **16**: 463–496.
- St John, G., Brot, N., Ruan, J., Erdjument-Bromage, H., Tempst, P., Weissbach, H., Nathan, C., 2001, Peptide methionine sulfoxide reductase from *Escherichia coli* and *Mycobacterium tuberculosis* protects bacteria against oxidative damage from reactive nitrogen intermediates. *Proc. Natl. Acad. Sci. USA* **98**: 9901–9906.
- Stehr, M., Hecht, H. J., Jaeger, T., Flohé, L., Singh, M., 2006, Structure of the inactive variant C60S of *Mycobacterium tuberculosis* thiol peroxidase. *Acta Crystallogr. D Biol. Crystallogr.* **62**: 563–567.
- Trujillo, M., Mauri, P., Benazzi, L., Comini, M., De Palma, A., Flohé, L., Radi, R., Stehr, M., Singh, M., Ursini, F., Jaeger, T., 2006, The mycobacterial thioredoxin peroxidase can act as a one-cysteine-peroxiredoxin. *J. Biol. Chem.* **281**: 20555–20566.

- Williams, C.H., Arscott, L.D., Muller, S., Lennon, B.W., Ludwig, M.L., Wang, P.F., Veine, D.M., Becker, K., Schirmer, R.H., 2000, Thioredoxin reductase two modes of catalysis have evolved. *Eur. J. Biochem.* **267**: 6110–6117.
- Wood, Z.A., Schröder, E., Harris, J.R., Poole, L.B., 2003, Structure, mechanism and regulation of peroxiredoxins, *Trends Biochem. Sci.* **28**: 32–40.
- Zhang, Y., Heym, B., Allen, B., Young, D., Cole, S., 1992, The catalase-peroxidase gene and isoniazid resistance of *Mycobacterium tuberculosis*. *Nature* **358**:591–593.
- Zhong, L., Holmgren, A., 2002, Mammalian thioredoxin reductases as hydroperoxide reductases. *Meth. Enzymol.* **347**: 236–243.

## CHAPTER 10

# PEROXIREDOXIN SYSTEMS OF PROTOZOAL PARASITES

MARCEL DEPONTE, STEFAN RAHLFS AND KATJA BECKER

*Interdisciplinary Research Center, Justus Liebig University, Heinrich-Buff-Ring 26–32, D-35392 Giessen, Germany*

**Abstract:** Cellular redox metabolism is considered to be involved in the pathophysiology of diseases caused by protozoal parasites such as *Toxoplasma*, *Trypanosoma*, *Leishmania*, and *Plasmodia*. Redox reactions furthermore are thought to play a major role in the action of and the resistance to some clinically used antiparasitic drugs. Interestingly, in malarial parasites, the antioxidant enzymes catalase and glutathione peroxidase are absent which indicates a crucial role of the thioredoxin system in redox control. Besides a glutathione peroxidase-like thioredoxin peroxidase and a glutathione *S*-transferase with slight peroxidase activity, *Plasmodium falciparum* (the causative agent of tropical malaria) possesses four classical peroxiredoxins: Two peroxiredoxins of the typical 2-Cys Prx class, one 1-Cys peroxiredoxin with homology to the atypical 2-Cys Prx class, and a peroxiredoxin of the 1-Cys Prx class have been identified and partially characterized

In our article we give an introduction to redox-based drug development strategies against protozoal parasites and summarize the present knowledge on peroxiredoxin systems in *Plasmodium*

**Keywords:** Drug development, Malaria, Oxidative stress, Peroxiredoxin, *Plasmodium*, Protozoal parasite

### 1. INTRODUCTION

Many protozoal parasites have stage-dependent high proliferation rates resulting in an increased demand for reducing equivalents in order to form deoxyribonucleoside diphosphates that are required for DNA synthesis. In addition, the high metabolic fluxes of proliferating parasites are thought to lead to an increased endogenous formation of reactive oxygen and nitrogen species (ROS, RNS) as well as redox-active by-products such as electrophilic 2-oxoaldehydes. The immune system of the host or the environment of intracellular parasites - for example the macrophage in the case of *Leishmania* spp. or the erythrocyte in the case of *Plasmodium* spp. - might

also increase the oxidative burden on the parasite. As a result the redox metabolism of many protozoal parasites (including apicomplexan parasites such as *Plasmodium falciparum* and *Toxoplasma gondii*, and the kinetoplastida *Trypanosoma brucei*, *T. cruzi*, and *Leishmania* spp.) is considered as a target for chemotherapy (for review see Becker et al., 2004; Krauth-Siegel et al., 2003; Krauth-Siegel et al., 2005; Müller, 2004; Müller et al., 2003; Rahlfs and Becker, 2006). The progress made over the last years in the fields of genomics, proteomics, and clinical medicine is essential to support such drug development approaches.

The protozoal parasite *Plasmodium falciparum* is responsible for approximately 500 million clinical cases of malaria and up to 2.7 million human deaths annually. As indicated by human glucose 6-phosphate dehydrogenase (G6PD) deficiency, limited availability of reducing equivalents in the form of NADPH confers protection from malaria, suggesting that malarial parasites are susceptible to oxidative stress. Furthermore, the antioxidant enzymes catalase and glutathione peroxidase (GPx) seem to be absent in the parasite. This constellation indicates that the thioredoxin system is of particular importance in the parasite and offers a potential for the development of urgently required novel chemotherapeutic agents. In addition, the redox metabolism may be involved in the pathology of malaria (for review see Becker et al., 2004).

For direct detoxification of reactive oxygen species *P. falciparum* possesses two superoxide dismutases and at least five proteins with homologies to thiol-dependent peroxidases (for reviews see Becker et al., 2004; Müller, 2004). Four peroxiredoxins (Prx) have been identified in *P. falciparum*; the characteristics of these proteins are summarized below. Apart from the four Prx, *P. falciparum* has a GPx-like thioredoxin peroxidase (*PfTPx<sub>GI</sub>*). As a non-selenocysteine GPx homologue, its reactions with hydroperoxides and glutathione (GSH) are three orders of magnitude slower than those of typical selenoperoxidases, and the protein was shown to be thioredoxin- rather than GSH-dependent (Sztajer et al., 2001). In addition, glutathione *S*-transferase of *Plasmodium* exhibits weak GSH-dependent peroxidase activity which might contribute to the total peroxide reducing capacity of the parasite because the enzyme is present in very high concentrations (for review see Deponte and Becker, 2005a).

## 2. TARGETING REDOX METABOLISM IN PROTOZOAL PARASITES

As mentioned above, differences in redox metabolism of the parasite and the host might be suited to identify novel drug targets (Rahlfs and Becker, 2006). The aim of this rational drug development approach is to find or to develop new antiparasitic substances that directly or indirectly inhibit the reduction of ribonucleoside diphosphates, ROS, RNS, or cytotoxic electrophilic compounds. Depending on the parasite and enzymes that are compared with the human host, differences in redox metabolism can be grouped into one of the three following categories:

### 2.1. Complete Lack or Substitution of One or More Components of the Redox System

For example in kinetoplastida the enzyme trypanothione reductase substitutes for glutathione reductase (GR) and thioredoxin reductase (TrxR). As a result - even though kinetoplastida possess thioredoxin (Trx) and GSH - the glutathione and thioredoxin systems present in most organisms are replaced by a system comprising trypanothione reductase, tryparedoxin, trypanothione [N1,N8-bis(glutathionyl)spermidine] and other tryparedoxin- or trypanothione-dependent enzymes (for review see Krauth-Siegel *et al.*, 2003; Krauth-Siegel *et al.*, 2005; Müller *et al.*, 2003; *see also* Chapter 11). Since this system is completely absent in the human host, it is considered as a very promising drug target.

In *P. falciparum* and trypanosomes neither catalase nor a selenocysteine-containing GPx has been identified. This observation was surprising because catalase and GPx are very efficient in detoxification of hydroperoxides (for review see Becker *et al.*, 2004; Flohé *et al.*, 2003; Hofmann *et al.*, 2002; Krauth-Siegel *et al.*, 2003). A putative hydroperoxidase deficiency might be partially compensated, because *P. falciparum* takes up erythrocytic catalase in its food vacuole (Clarebout *et al.*, 1998). Studies *in vitro* however suggest, that detoxification of hydroperoxides in *Trypanosoma* (for review see Flohé *et al.*, 2003; Hofmann *et al.*, 2002; Krauth-Siegel *et al.*, 2003), in *Plasmodium* (for review see Nickel *et al.*, 2006), and maybe in *T. gondii* (Akerman and Müller, 2005, Ding *et al.*, 2004) depends on peroxiredoxins.

### 2.2. Differences in the Number and/or the Substrate Specificity of Similar Enzymes

The thioredoxin and the glutathione system of *P. falciparum* for example include a large repertoire of small (putative) redox proteins that have high sequence similarities with Trx and glutaredoxins (Grx), some of them are specific for the parasite (Deponte *et al.*, 2005; for review see Nickel *et al.*, 2006). In contrast to most higher organisms that possess several glutathione S-transferase (GST) isoforms, the malaria parasite has only one canonical GST that cannot be assigned to any of the previously reported GST classes (for review see Deponte and Becker, 2005a) and some of the *P. falciparum* Prx differ from its human host as far as type and number are concerned (see below).

The knowledge of completed genome sequencing projects tempt researchers to assume that similar proteins fulfil the same functions; heterofunctional homologues and isofunctional homologues (for definition see Jensen, 2001) are frequently not discriminated from each other. As a consequence wrong functions can be assigned to homologous proteins in case predictions are solely based on *in silico* analyses. For example *P. falciparum* (Sztajer *et al.*, 2001) and *T. cruzi* (Krauth-Siegel *et al.*, 2003; Wilkinson *et al.*, 2002) both possess a putative glutathione-dependent GPx

with a cysteine residue replacing the selenocysteine residue of most mammalian GPx (for review see Flohé *et al.*, 2003). In contrast to mammalian GPx, the parasite enzymes *Pf*TPx<sub>GI</sub> (for nomenclature see Rahlfs *et al.*, 2002) and *Tc*GPxI are much more efficient with Trx and tryparedoxin respectively, than with GSH as reducing substrate (Sztajer *et al.*, 2001; Wilkinson *et al.*, 2002). In general, both the reducing and the oxidizing substrates of thiol-dependent hydroperoxidases differ significantly from enzyme to enzyme and cannot be easily predicted from sequence alignments (for review see Flohé *et al.*, 2003).

### 2.3. Different Properties of Isofunctional Homologous Proteins

Very similar isofunctional enzymes can still be good drug targets as long as one exploitable protein biochemical parameter (such as localisation, protein structure, intracellular concentration etc.) differs significantly between the parasite and the host protein. One good example is the ornithine decarboxylases (OD) from man and *Trypanosoma brucei gambiense*. OD is required for the production of spermidine, a component of trypanothione, and both enzymes from man and *T. brucei gambiense* are inactivated by the suicide inhibitor  $\alpha$ -difluoromethylornithine (DFMO). In contrast to the parasite enzyme, the *in vivo* half-life of the human enzyme is very short (a few minutes). Human enzyme molecules are far more rapidly replaced than the parasite enzyme molecules, resulting in the selective killing of trypanosomes (for review see Krauth-Siegel *et al.*, 2005). Other examples of isofunctional enzymes serving as potential drug targets are *P. falciparum* glutathione reductase (GR) and glutathione *S*-transferase (GST) (for reviews see Becker *et al.*, 2004; Deponete and Becker, 2005a): *Pf*GR shows remarkable differences to the human enzyme at the dimer interface and the subunit cavity which differs in architecture and electrostatic properties. This cavity has been verified to serve as the binding site for *Pf*GR inhibitors. *Pf*GST – the three-dimensional structure of which has also been solved – represents a novel GST class as demonstrated by structural and functional properties. Particularly the H-site which binds the hydrophobic or amphiphilic substrate for the conjugation reaction with glutathione differs significantly and is presently being exploited as an inhibitor binding site. So far there is only very limited knowledge of the essentiality, the physiological half-life, and the protein structure of parasite Prx compared with their human counterparts.

## 3. PROPERTIES OF *PLASMODIUM* PEROXIREDOXINS

Four Prx have been described in *P. falciparum*: *P. falciparum* thioredoxin peroxidases 1 and 2 (*Pf*TPx-1, *Pf*TPx-2), antioxidant protein (*Pf*AOP), and 1-Cys peroxiredoxin (*Pf*1-Cys-Prx). The following paragraphs summarize our knowledge of the enzymatic, structural and cellular properties of these proteins.

### 3.1. Thioredoxin Peroxidase 1 (TPx-1)

**Enzymatic activity:** TPx-1 is the best studied Prx from *P. falciparum* so far. The recombinant enzyme can be reduced by thioredoxin (Rahlfs and Becker, 2001; Akerman and Müller, 2003) and plasmoredoxin (Nickel *et al.*, 2005). Using Trx as a reducing substrate TPx-1 efficiently cleaves H<sub>2</sub>O<sub>2</sub> ( $k_{\text{cat}}/K_m \sim 6.7 \times 10^6 \text{ M}^{-1}\text{s}^{-1}$  at pH 7.6 and 30 °C; Akerman and Müller, 2003) and peroxynitrite ( $k_{\text{cat}}/K_m \sim 1 \times 10^6 \text{ M}^{-1}\text{s}^{-1}$  at pH 7.4 and 37 °C; Nickel *et al.*, 2005). Furthermore, the enzyme accepts *tert*-butylhydroperoxide, and cumene hydroperoxide as organic peroxide substrates (Rahlfs and Becker, 2001).

**Structure:** TPx-1 shares 47% amino acid sequence identity to human PrxII and has been classified mechanistically as a typical 2-Cys Prx based on sequence alignments (Rahlfs and Becker, 2001; Kawazu *et al.*, 2001). In 2003 Akerman and Müller detected doughnut-like ( $\alpha_2$ )<sub>5</sub> decameric structures of recombinant TPx-1 by gel filtration chromatography and electron microscopy. Although no X-ray structure of the enzyme is solved yet, the hypothesis that Cys<sup>50</sup> and Cys<sup>170</sup> of TPx-1 are the peroxidatic and resolving cysteine residue, respectively, was experimentally confirmed using site-directed mutagenesis, molecular modeling, and reducing and non-reducing SDS-PAGE (Nickel *et al.*, 2005). According to the molecular models of TPx-1, Cys<sup>50</sup> is located near Arg<sup>125</sup> and Thr<sup>47</sup>, forming the classical active site of 2-Cys Prx. All but four residues of the dimer-dimer interface region II (for review see Wood *et al.*, 2003a) of TPx-1 (Ser<sup>75</sup>-Pro<sup>89</sup>) and human PrxII are identical, partially explaining the similar oligomerization behaviour (Nickel *et al.*, 2005). The interface region II of both enzymes includes a conserved threonine residue that is target for phosphorylation probably triggering the decomposition and/or enzymatic activity of human PrxII (for review see Wood *et al.*, 2003a). To date it is not clear whether TPx-1 is regulated in a similar manner.

**Cellular properties:** TPx-1 of *P. falciparum* and of the rodent parasite *P. yoelii* are constitutively expressed throughout the asexual erythrocytic blood stages. The enzyme localizes to the cytoplasm (Fig. 1) and might play a housekeeping role in the parasite's intracellular redox metabolism (Kawazu *et al.*, 2003; Yano *et al.*, 2005). In response to exogenous oxidative stress, protein and mRNA levels of *P. falciparum* TPx-1 are increased (Akerman and Müller, 2003). Furthermore, the contribution of TPx-1 to peroxide detoxification *in vivo* has been studied using knock-out parasites: Erythrocytic blood stages of *P. falciparum* TPx-1 knock-out parasites exhibit a reduced growth rate when treated with paraquat and sodium nitroprusside in comparison with wild-type parasites suggesting that the enzyme is involved in protecting the parasite against oxidative and nitrosative stress. In the absence of these compounds, however, knock-out parasites grow normally (Komaki-Yasuda *et al.*, 2003). Thus, TPx-1 is not essential for the detoxification of endogenously produced ROS and/or RNS in *Plasmodium* cultures. This conclusion is supported by *in vivo* studies on the rodent parasite *P. berghei* (Yano *et al.*, 2006): TPx-1 knock-out parasites develop normally in mouse erythrocytes and multiply at a rate similar to that of the wild-type strain. Interestingly, there might be a connection between formation of gametocytes (sexual blood stages that are transferred to the

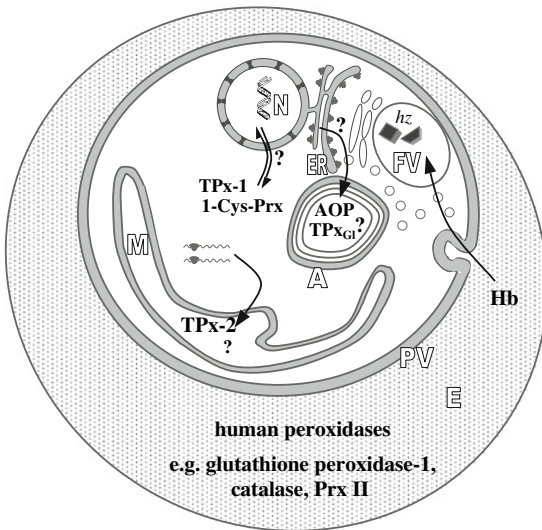

*Figure 1.* Cellular localization of human and *P. falciparum* hydroperoxidases. The parasite (trophozoite stage) is surrounded by a parasitophorous vacuole (PV) separating the erythrocyte (E) and the parasite cytoplasm. The asexual development of *P. falciparum* is coupled to the vesicular uptake of hemoglobin (Hb) and other erythrocytic proteins. Very little is known about the function of human peroxidases that are taken up by the parasite. During the proteolytic degradation of haemoglobin, heme is released and detoxified as crystalline hemozoin (hz) inside the parasite's food vacuole (FV). In contrast to human PrxI – which is known to be partially located in the nucleus – it is unclear whether cytosolic TPx-1 and 1-Cys-Prx are able to enter the parasite's nucleus (N). The localization of AOP and TPx<sub>GI</sub> inside the apicoplast (A) – which is closely associated with the endoplasmic reticulum (ER) – is based on predictions *in silico* and has to be confirmed experimentally. Furthermore, the localization of putative physiological reducing substrates of AOP and TPx<sub>GI</sub> (in the apicoplast) and of TPx-2 in the mitochondrion (M) has not been studied so far (potential electron donors and their predicted localizations are reviewed in Nickel *et al.*, 2006; Rahlfs and Becker, 2006)

mosquito during a blood meal) and Prx because *TPx-1* knock-out parasites produce up to 60% fewer gametocytes (Yano *et al.*, 2006).

### 3.2. Thioredoxin Peroxidase 2 (TPx-2)

So far not very much is known about TPx-2 which has been classified mechanistically as a typical 2-Cys Prx based on sequence alignments (Rahlfs and Becker, 2001). The protein shares more than 50% sequence identity with TPx-1, possesses a mitochondrial targeting sequence (Rahlfs and Becker, 2001) and localizes to the mitochondria of the asexual erythrocytic blood stages (Yano *et al.*, 2005). *TPx-2* is expressed during trophozoite and schizont stages (Yano *et al.*, 2005), but it remains unclear whether the protein is active and what the substrates are. Furthermore, it is not even known whether there is a complete mitochondrial thioredoxin system



comprising a mitochondrial TrxR and a Trx that might transfer reducing equivalents to TPx-2 (Fig. 1; Nickel *et al.*, 2006).

### 3.3. Antioxidant Protein (AOP)

**Enzymatic activity:** Although a detailed enzymatic analysis of recombinant *P. falciparum* AOP still has to be performed (using for example stopped-flow kinetics instead of steady-state kinetics), initial studies show that the enzyme can be reduced by Grx and to a lesser extent by Trx. Furthermore, AOP also accepts electrons from plasmoredoxin (Nickel *et al.*, 2006). Preferred hydroperoxide substrates of AOP are *tert*-butylhydroperoxide, and phosphatidylcholine hydroperoxide, whereas H<sub>2</sub>O<sub>2</sub> and cumene hydroperoxide are reduced less efficiently (Nickel *et al.*, 2006).

**Structure:** According to sequence similarities AOP is a PrxV-like Prx that has a putative N-terminal targeting sequence (Nickel *et al.*, 2006). However, in contrast to human PrxV which is an atypical 2-Cys Prx (for review see Wood *et al.*, 2003a), the X-ray structure of AOP shows that the *P. falciparum* enzyme acts on the basis of a 1-Cys mechanism (Sarma *et al.*, 2005). AOP without the putative targeting sequence forms stable non-covalently linked dimers in the crystal and in solution. The peroxidatic cysteine residue Cys<sup>59</sup> is 'over'-oxidized to a sulfonate in the crystallized protein and interacts with Thr<sup>56</sup> and Arg<sup>137</sup>. In addition to the Prx core elements, AOP has a short helix inserted between strands  $\beta$ 1 and  $\beta$ 2, a single residue insertion (Thr<sup>61</sup>) following Cys<sup>59</sup> (a so-called  $\alpha$ -aneurism), and two antiparallel  $\beta$ -strands and a  $3_{10}$ -helix inserted between helix  $\alpha$ 4 and strand  $\beta$ 6 (Sarma *et al.*, 2005). A comparison of the structure of AOP and other Prx led to the hypothesis that susceptibility of any given Prx to 'over'-oxidation to the cysteine sulfinate or sulfonate depends not just on the thermodynamics of active site unfolding (Wood *et al.*, 2003b) but also on the ease with which the structure can accommodate the (presumably) rotating oxygen atoms of the sulfinate or sulfonate in the so-called O <sup>$\delta$ 2</sup> and/or O <sup>$\delta$ 3</sup> positions, respectively (Sarma *et al.*, 2005). The study on AOP furthermore led to the introduction of a novel structural classification of Prx based on the so-called A-type and B-type dimerization interface architecture (Sarma *et al.*, 2005).

**Cellular properties:** Data available on the *Plasmodium* data base PlasmoDB (<http://www.plasmodb.org/>) show that AOP is constitutively expressed throughout the erythrocytic blood stages. Analyses *in silico* predict localization to the apicoplast (Fig. 1; Nickel *et al.*, 2006) - a plastid-like essential organelle derived by secondary endosymbiosis of an alga (Roos *et al.*, 2002) - but no localization studies in *P. falciparum* have been performed as yet. In this context, it will be interesting to study whether the putative apicoplast proteins Trx2 and Trx3 (Nickel *et al.*, 2006) are able to reduce AOP and to identify their reducing agents.

### 3.4. 1-Cys Peroxiredoxin (1-Cys-Prx)

**Enzymatic activity:** 1-Cys-Prx was studied independently in different laboratories resulting in different assumptions with respect to activity and substrate spectrum of

the enzyme (for review see Nickel *et al.*, 2006). 1-Cys-Prx is able to accept electrons from Grx and Trx and to reduce  $H_2O_2$  and *tert*-butylhydroperoxide (Nickel *et al.*, 2006). However, as far as steady-state kinetics are concerned the protein shows only weak thiol-dependent hydroperoxidase activity (order of magnitude  $\leq 20$  U/g) suggesting that one or both of the substrates tested is/are not efficiently utilised under physiological conditions (but it cannot be excluded that the catalytic efficiency may increase under anaerobic and/or stopped flow conditions). The protein also protects glutamine synthetase against a dithiothreitol  $Fe^{3+}$ -catalyzed oxidation system, but does not use GSH as a substrate (Kawazu *et al.*, 2005; Nickel *et al.*, 2006), even though one of the eight cysteine residues of 1-Cys-Prx can be glutathionylated after incubation of recombinant protein with GSH or GSSG (Nickel *et al.*, 2006).

**Structure:** Recently the homologous proteins 1-Cys-Prx from *P. falciparum* and TgPrx2 from *T. gondii* were compared using molecular models, site directed mutagenesis, gel filtration chromatography, and reducing and non-reducing SDS-PAGE (Deponte and Becker, 2005b; Nickel *et al.*, 2006). In contrast to the other *Plasmodium* Prx the peroxidatic cysteine residue Cys<sup>47</sup> of Pfl-Cys-Prx and TgPrx2 presumably interacts with His<sup>39</sup> in addition to the conserved threonine residue at the active site (Deponte and Becker, 2005b). Residue Cys<sup>209</sup> - which is involved in covalent dimerization of TgPrx2 - is absent in Pfl-Cys-Prx. Furthermore, the oligomerization of Pfl-Cys-Prx and TgPrx2 *in vitro* are very different; in contrast to TgPrx2 - which tends to form covalently linked dimers as well as non-covalently linked tetramers and hexamers (Deponte and Becker, 2005b) - aged and/or oxidized Pfl-Cys-Prx does not form significant amounts of higher aggregates but tends to monomerize (Nickel *et al.*, 2006). Thus, despite 47% identical amino acid residues Pfl-Cys-Prx possesses characteristic features of 1-Cys Prx, whereas TgPrx2 shows similarities to typical 2-Cys Prx.

**Cellular properties:** Expression of *1-Cys-Prx* is elevated during the trophozoite and schizont stage (Kawazu *et al.*, 2003; Yano *et al.*, 2005). Using recombinant 1-Cys-Prx and ferriprotoporphyrin IX bound to agarose it has recently been suggested that an interaction between cytosolic 1-Cys-Prx and ferriprotoporphyrin IX protects *P. falciparum* from oxidative stress (Kawazu *et al.*, 2005). This hypothesis is based on studies showing that only 30% of ferriprotoporphyrin IX (FP) - which is produced during heme digestion in the parasite's food vacuole (Fig. 1) - is polymerized and detoxified as hemozoin (Ginsburg *et al.*, 1998). According to this model large amounts of residual FP are thought to diffuse from the food vacuole into the cytosol (Ginsburg *et al.*, 1998) where the FP may be degraded by glutathione (Atamna and Ginsburg, 1995), even though the product of this putative degradation is not known. This 'FP-cytosol-diffusion' model is speculative and there are two studies contradicting it. The first study suggests that the remaining FP is degraded in the food vacuole at acidic pH by non-enzymic processes (Loria *et al.*, 1999). The second study is even more important because it uses more accurate measurements such as Mössbauer-spectroscopy to determine the fate of iron in the parasite. The conclusion is that  $92 \pm 6\%$  of the parasite's iron is located within the food vacuole and that of this  $88 \pm 9\%$  is in the form of

haemozoin (Egan *et al.*, 2002). In addition, other highly concentrated cytosolic *P. falciparum* proteins such as glutathione *S*-transferase also bind tightly to FP (Hiller *et al.*, 2006). Against this background, a role of 1-Cys-Prx in heme detoxification seems unlikely.

#### 4. FUTURE PERSPECTIVES

As a conclusion, it is justified to say that we are just at the beginning to understand the physiological functions of *Plasmodium* Prx. Presently different research groups concentrate on the extended characterization of the kinetic properties of these proteins. So far, only the reactions catalysed by PfTPx-1 have been described in detail. To gain more insight into the functional properties of the proteins a clear definition of their subcellular localization, e.g. by using GFP fusion constructs, is essential. In Fig. 1 we summarize the (putative) localization of the different Prx and other redox components in malarial parasites. Based on experimental data and on predictions using presently available protein targeting programs the parasite possesses functional Prx in the cytosol, the apicoplast and the mitochondria. The physiological stage- and compartment-specific reactions catalysed by these proteins and their interacting partners remain to be elucidated. To tackle this challenge and to study the potential of PfPrx as drug targets, gene knock-out and knock-down studies will be of great value. The lack of an abnormal phenotype of the TPx-1 knock-out parasites - despite the absence of catalase and GPx - does presently not fit in our construct of ideas. It is noteworthy that - in contrast to yeast (Biteau *et al.*, 2003) and mammals (Jeong *et al.*, 2006) - no sulfiredoxin has been identified as yet in *P. falciparum*. To date it, is furthermore unknown whether *Plasmodium* Prx are involved in signal transduction (for example Veal *et al.*, 2004; for review see Hofmann *et al.*, 2002; and Wood *et al.*, 2003a), or whether they possess a kind of chaperone activity (Jang *et al.*, 2004) as demonstrated for Prx from other organisms. Apart from functional studies, the three-dimensional structures of three out of the four Prx remain to be elucidated. Inhibitor screening and the characterization of enzyme-inhibitor complexes will demonstrate if Prx of malarial parasites are suitable candidates for targeted drug development.

#### ACKNOWLEDGEMENTS

This study was supported by the Deutsche Forschungsgemeinschaft (SFB 535, project A12 to K.B. and M.D.).

#### REFERENCES

- Abe, K., Saito, H., 2000, Amyloid  $\beta$  neurotoxicity not mediated by the mitogen-activated protein kinase cascade in cultured rat hippocampal and cortical neurons. *Neurosci. Lett.* **292**: 1–4.
- Akerman, S.E., Müller, S., 2003, 2-Cys peroxiredoxin PfTrx-Px1 is involved in the antioxidant defence of *Plasmodium falciparum*. *Mol. Biochem. Parasitol.* **130**: 75–81.

- Akerman, S.E., Müller, S., 2005, Peroxiredoxin-linked detoxification of hydroperoxides in *Toxoplasma gondii*. *J. Biol. Chem.* **280**: 564–570.
- Atamna, H., Ginsburg, H., 1995, Heme degradation in the presence of glutathione: a proposed mechanism to account for the high levels of non-heme iron found in the membranes of hemoglobinopathic red blood cells. *J. Biol. Chem.* **270**: 24876–24883.
- Becker, K., Tilley, L., Vennerstrom, J.L., Roberts, D., Rogerson, S., Ginsburg, H., 2004, Oxidative stress in malaria parasite-infected erythrocytes: host-parasite interactions. *Int. J. Parasitol.* **34**: 163–189.
- Biteau, B., Labarre, J., Toledano, M. B., 2003, ATP-dependent reduction of cysteine-sulphinic acid by *S. cerevisiae* sulphiredoxin. *Nature* **425**: 980–984.
- Clarebout, G., Slomianny, C., Delcourt, P., Leu, B., Masset, A., Camus, D., Dive, D., 1998, Status of *Plasmodium falciparum* towards catalase. *Br. J. Haematol.* **103**: 52–59.
- Deponte, M., Becker, K., 2005a, Glutathione S-transferase from malarial parasites: structural and functional aspects. *Methods Enzymol.* **401**: 241–253.
- Deponte, M., Becker, K., 2005b, Biochemical characterization of *Toxoplasma gondii* 1-Cys peroxiredoxin 2 with mechanistic similarities to typical 2-Cys Prx. *Mol. Biochem. Parasitol.* **140**: 87–96.
- Deponte, M., Becker, K., Rahlfs, S., 2005, *Plasmodium falciparum* glutaredoxin-like proteins. *Biol. Chem.* **386**: 33–40.
- Ding, M., Kwok, L.Y., Schlüter, D., Clayton, C., Soldati, D., 2004, The antioxidant systems in *Toxoplasma gondii* and the role of cytosolic catalase in defence against oxidative injury. *Mol. Microbiol.* **51**: 47–61.
- Egan, T.J., Combrinck, J.M., Egan, J., Hearne, G.R., Marques, H.M., Ntenti, S., Sewell, B. T., Smith, P.J., Taylor, D., van Schalkwyk, D.A., Walden, J.C., 2002, Fate of haem iron in the malaria parasite *Plasmodium falciparum*. *Biochem. J.* **365**: 343–347.
- Flohé, L., Jaeger, T., Pilawa, S., Sztajer, H., 2003, Thiol-dependent peroxidases care little about homology-based assignments of function. *Redox Rep.* **8**: 256–264.
- Ginsburg, H., Famin, O., Zhang, J., Krugliak, M., 1998, Inhibition of glutathione-dependent degradation of heme by chloroquine and amodiaquine as a possible basis for their antimalarial mode of action. *Biochem. Pharmacol.* **56**: 1305–1313.
- Hiller, N., Fritz-Wolf, K., Deponte, M., Wende, W., Zimmermann, H., Becker, K., 2006, *Plasmodium falciparum* glutathione S-transferase – structural and mechanistic studies on ligand binding and enzyme inhibition. *Protein Sci.* **15**: 281–289.
- Hofmann, B., Hecht, H. J., Flohé, L., 2002, Peroxiredoxins. *Biol. Chem.* **383**: 347–364.
- Jang, H.H., Lee, K.O., Chi, Y.H., Jung, B.G., Park, S.K., Park, J.H., Lee, J.R., Lee, S.S., Moon, J.C., Yun, J.W., Choi, Y.O., Kim, W.Y., Kang, J.S., Cheong, G.W., Yun, D.J., Rhee, S.G., Cho, M.J., Lee, S.Y., 2004, Two enzymes in one; two yeast peroxiredoxins display oxidative stress-dependent switching from a peroxidase to a molecular chaperone function. *Cell* **117**: 625–635.
- Jensen, R.A., 2001, Orthologs and paralogs - we need to get it right. *Genome Biol.* **2**: 1002.
- Jeong, W., Park, S.J., Chang, T.S., Lee, D.Y., Rhee, S.G., 2006, Molecular mechanism of the reduction of cysteine sulfinic acid of peroxiredoxin to cysteine by mammalian sulfiredoxin. *J. Biol. Chem.* **281**: 14400–14407.
- Kawazu, S., Komaki, K., Tsuji, N., Kawai, S., Ikenoue, N., Hatabu, T., Ishikawa, H., Matsumoto, Y., Himeno, K., Kano S., 2001, Molecular characterization of a 2-Cys peroxiredoxin from the human malaria parasite *Plasmodium falciparum*. *Mol. Biochem. Parasitol.* **116**: 73–79.
- Kawazu, S., Nozaki, T., Tsuboi, T., Nakano, Y., Komaki-Yasuda, K., Ikenoue, N., Torii, M., Kano, S., 2003, Expression profiles of peroxiredoxin proteins of the rodent malaria parasite *Plasmodium yoelii*. *Int. J. Parasitol.* **33**: 1455–1461.
- Kawazu, S., Ikenoue, N., Takemae, H., Komaki-Yasuda, K., Kano, S., 2005, Roles of 1-Cys peroxiredoxin in haem detoxification in the human malaria parasite *Plasmodium falciparum*. *FEBS J.* **272**: 1784–1791.
- Komaki-Yasuda, K., Kawazu, S., Kano, S., 2003, Disruption of the *Plasmodium falciparum* 2-Cys peroxiredoxin gene renders parasites hypersensitive to reactive oxygen and nitrogen species. *FEBS Lett.* **547**: 140–144.

- Krauth-Siegel, R.L., Bauer, H., Schirmer, R.H., 2005, Dithiol proteins as guardians of the intracellular redox milieu in parasites: old and new drug targets in trypanosomes and malaria-causing *plasmodia*. *Angew. Chem. Int. Ed. Engl.* **44**: 690–715.
- Krauth-Siegel, R.L., Meiering, S.K., Schmidt, H., 2003, The parasite-specific trypanothione metabolism of *trypanosoma* and *leishmania*. *Biol. Chem.* **384**:539–49.
- Loria, P., Miller, S., Foley, M., Tilley, L., 1999, Inhibition of the peroxidative degradation of haem as the basis of action of chloroquine and other quinoline antimalarials. *Biochem. J.* **339**:363–370.
- Müller, S., 2004, Redox and antioxidant systems of the malaria parasite *Plasmodium falciparum*. *Mol. Microbiol.* **53**:1291–1305.
- Müller, S., Liebau, E., Walter, R.D., Krauth-Siegel, R.L., 2003, Thiol-based redox metabolism of protozoan parasites. *Trends Parasitol.* **19**: 320–328.
- Nickel, C., Rahlfs, S., Deponte, M., Koncarevic, S., Becker, K. 2006, Thioredoxin networks in the malarial parasite *Plasmodium falciparum*. *Antioxid. Redox Signal.* **8**: 1227–1239.
- Nickel, C., Trujillo, M., Rahlfs, S., Deponte, M., Radi, R., Becker, K., 2005, *Plasmodium falciparum* 2-Cys peroxiredoxin reacts with plasmoredoxin and peroxynitrite. *Biol. Chem.* **386**: 1129–1136.
- Rahlfs, S., Becker, K., 2001, Thioredoxin peroxidases of the malarial parasite *Plasmodium falciparum*. *Eur. J. Biochem.* **268**: 1404–1409.
- Rahlfs, S., Becker, K., 2006, Interference with redox-active enzymes as a basis for the design of antimalarial drugs. *Mini Rev. Med. Chem.* **6**: 163–176.
- Rahlfs, S., Schirmer, R.H., Becker, K., 2002, The thioredoxin system of *Plasmodium falciparum* and other parasites. *Cell. Mol. Life Sci.* **59**:1024–1041.
- Roos, D.S., Crawford, M.J., Donald, R.G.K., Fraunholz, M., Harb, O.S., He, C.Y., Kissinger, J.C., Shaw, M.K., Striepen, B., 2002, Mining the *Plasmodium* genome database to define organellar function: what does the apicoplast do? *Phil. Trans. R. Soc. Lond.* **357**: 35–46.
- Sarma, G.N., Nickel, C., Rahlfs, S., Fischer, M., Becker, K., Karplus, P.A., 2005, Crystal structure of a novel *Plasmodium falciparum* 1-Cys peroxiredoxin. *J. Mol. Biol.* **346**: 1021–1034.
- Sztajer, H., Gamain, B., Aumann, K. D., Slomianny, C., Becker, K., Brigelius-Flohé, R., Flohé, L., 2001, The putative glutathione peroxidase gene of *Plasmodium falciparum* codes for a thioredoxin peroxidase. *J. Biol. Chem.* **276**: 7397–7403.
- Veal, E.A., Findlay, V.J., Day, A.M., Bozonet, S.M., Evans, J.M., Quinn, J., Morgan, B.A., 2004, A 2-Cys peroxiredoxin regulates peroxide-induced oxidation and activation of a stress-activated MAP kinase. *Mol. Cell.* **15**:129–139.
- Wilkinson, S.R., Meyer, D.J., Taylor, M.C., Bromley, E.V., Miles, M.A., Kelly, J.M., 2002, The *Trypanosoma cruzi* enzyme TcGPXI is a glycosomal peroxidase and can be linked to trypanothione reduction by glutathione or trypanedoxin. *J. Biol. Chem.* **277**:17062–17071.
- Wood, Z.A., Schröder, E., Harris, J.R., Poole, L.B. 2003a, Structure, mechanism and regulation of peroxiredoxins. *Trends Biochem. Sci.* **28**: 32–40.
- Wood, Z. A., Poole, L. B. and Karplus, P. A., 2003b, Peroxiredoxin evolution and the regulation of hydrogen peroxide signaling. *Science* **300**: 650–653.
- Yano, K., Komaki-Yasuda, K., Kobayashi, T., Takemae, H., Kita, K., Kano, S., Kawazu, S., 2005, Expression of mRNAs and proteins for peroxiredoxins in *Plasmodium falciparum* erythrocytic stage. *Parasitol. Int.* **54**: 35–41.
- Yano, K., Komaki-Yasuda, K., Tsuboi, T., Torii, M., Kano, S., Kawazu, S.I., 2006, 2-Cys Peroxiredoxin TPx-1 is involved in gametocyte development in *Plasmodium berghei*. *Mol. Biochem. Parasitol.* **148**: 44–51.

Note: During the preparation of this manuscript, Ian Boucher and colleagues published a detailed study on PfTPx-2 describing the crystal structure, the mitochondrial localization and the substrate spectrum of the enzyme (Boucher, I.W., McMillan, P.J., Gabrielsen, M., Akerman, S.E., Brannigan, J.A., Schnick, C., Brzozowski, A.M., Wilkinson, A.J., Müller, S., 2006, Structural and biochemical characterization of a mitochondrial peroxiredoxin from *Plasmodium falciparum*. *Mol. Microbiol.* 61:948–959).

## CHAPTER 11

# THE TRYPANOTHIONE SYSTEM

LUISE R. KRAUTH-SIEGEL, MARCELO A. COMINI  
AND TANJA SCHLECKER

*Biochemie-Zentrum der Universität Heidelberg, Im Neuenheimer Feld 504, D-69120,  
Heidelberg, Germany*

**Abstract:** Trypanosomes and *Leishmania*, the causative agents of severe tropical diseases, employ 2-Cys-peroxiredoxins together with cysteine-homologues of glutathione peroxidases and ascorbate-dependent peroxidases for the detoxification of hydroperoxides. All three types of peroxidases gain their reducing equivalents from the parasite-specific dithiol trypanothione [bis(glutathionyl)spermidine]. Based on their primary structure and cellular localization, the trypanosomatid 2-Cys-peroxiredoxins are subdivided into two families that occur in the mitochondrion and cytosol of the parasites. In *Trypanosoma brucei*, the cytosolic 2-Cys-peroxiredoxin, as well as the glutathione peroxidase-type enzyme, is essential for cell viability. Despite overlapping substrate specificities and subcellular localizations, the two types of peroxidases can obviously not substitute for each other which suggests distinct cell-physiological roles

**Keywords:** Trypanothione, Tryparedoxin, Trypanosoma, Oxidative stress, Hydroperoxide, Glutathione, Peroxidase, Peroxiredoxin

## 1. INTRODUCTION

Trypanosomes and *Leishmania* are unicellular parasites of the family *Trypanosomatidae* and the order *Kinetoplastida* to which belong the causative agents of African sleeping sickness (*Trypanosoma brucei gambiense* and *T. b. rhodesiense*), Nagana cattle disease (*T. congolense*, *T. b. brucei*), American Chagas' disease (*T. cruzi*) and the different forms of leishmaniasis (*L. donovani*, *L. major*). One of the numerous peculiarities of trypanosomatids is that their thiol and polyamine metabolisms are directly linked.  $N^1$ -mono(glutathionyl)spermidine (Gsp) and trypanothione [ $N^1$ ,  $N^8$ -bis(glutathionyl)spermidine, T(SH)<sub>2</sub>] are the main low molecular mass thiols which are kept reduced by the flavoenzyme trypanothione reductase (TR). Glutathione reductase and thioredoxin reductase – which in nearly all organisms are responsible for maintaining a reducing intracellular milieu – are missing (for a recent review see Krauth-Siegel *et al.*, 2005).

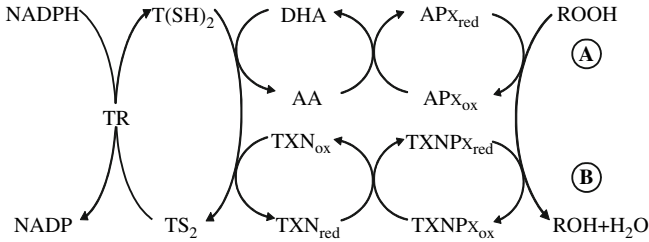

*Figure 1.* Trypanothione-dependent hydroperoxide detoxification in trypanosomatids. Trypanosomatids have three types of peroxidases all of which catalyze the trypanothione-dependent reduction of hydroperoxides. Trypanothione [T(SH)<sub>2</sub>] generated by trypanothione reductase (TR) spontaneously reduces dehydroascorbate (DHA) as well as oxidized trypanoxin (TXN<sub>ox</sub>). A, Ascorbate (AA) and B, reduced trypanoxin (TXN<sub>red</sub>) deliver the electrons to the oxidized form of an ascorbate peroxidase (APX<sub>ox</sub>) and the 2-Cys-peroxiredoxin as well as glutathione peroxidase-type trypanoxin peroxidases (TXNPX<sub>ox</sub>), respectively. The reduced peroxidases APX<sub>red</sub> and TXNPX<sub>red</sub> finally catalyze the reduction of hydroperoxides (ROOH)

During their life cycle, the parasites are exposed to various reactive oxygen intermediates such as superoxide anions, hydrogen peroxide and products of the host myeloperoxidase system. However, their ability to cope with oxidative stress seems to be surprisingly weak. Trypanosomes and *Leishmania* spp. possess superoxide dismutase, but catalase and classical selenocysteine-containing glutathione peroxidases are missing. 2-Cys-peroxiredoxins as well as cysteine-homologous glutathione peroxidases, and in some species also ascorbate-dependent peroxidases, reduce hydroperoxides. All three types of peroxidases depend on the trypanothione/TR couple as electron source (Fig. 1).

## 2. THE PARASITE SPECIFIC DITHIOL TRYPANOTHIONE

### 2.1. Occurrence and Biosynthesis of Trypanothione

The stepwise conjugation of two molecules of glutathione (GSH) with one spermidine molecule to *N*<sup>1</sup>-mono(glutathionyl)spermidine and subsequently to trypanothione (Fairlamb *et al.*, 1985) is catalyzed by glutathionylspermidine synthetase (GspS) and trypanothione synthetase (TryS). Both enzymes are composed of a C-terminal synthetase-domain and an N-terminal amidase-domain which can hydrolyze the products to restore GSH and spermidine. This paradox activity, rather than being a futile-cycle, has been suggested to regulate the intracellular polyamine and/or GSH levels under certain environmental or cell cycle/growth conditions (Shim and Fairlamb, 1988; Bollinger *et al.*, 1995).

GspS from the insect parasite *Crithidia fasciculata* exclusively forms Gsp (Koenig *et al.*, 1997; Oza *et al.*, 2002a), whereas the TrySs from different species have a broader specificity and accept both spermidine and Gsp as substrates to finally generate T(SH)<sub>2</sub> (Oza *et al.*, 2002b, 2003 and 2005; Comini *et al.*, 2003 and 2005). In the individual trypanosomatids, trypanothione synthesis shows some

differences. *T. brucei* relies entirely on a TryS to accomplish T(SH)<sub>2</sub>-production and lacks a GspS-gene (Comini *et al.*, 2004; Ariyanayagam *et al.*, 2005). *L. major* encodes a single TryS gene and a redundant GspS pseudogene (Oza *et al.*, 2005). *T. cruzi* possesses a TryS that, in addition to spermidine, accepts spermine as substrate to form homotrypanothione (Oza *et al.*, 2002b), and encodes a putative GspS gene (Acc. N° EAN98995). In *C. fasciculata*, active TryS and GspS, in authentic and recombinant form, have been investigated (Henderson *et al.*, 1990; Koenig *et al.*, 1997; Oza *et al.*, 2002a; Comini *et al.*, 2005).

Glutathionylspermidine, but not trypanothione, is also formed in *Escherichia coli* under stationary phase conditions (Tabor and Tabor, 1975). The occurrence of a trypanothione metabolism in the amitochondriate protozoan *Entamoeba histolytica* remains a matter of debate (Ondarza *et al.*, 1997; Ariyanayagam and Fairlamb, 1999), although a trypanothione reductase gene (Acc. N° AF503571), TR activity and T(SH)<sub>2</sub> have been detected (Ondarza *et al.*, 1997 and 2005). The presence of both trypanothione reductase and glutathione reductase has been described in the phytoflagellated protozoan *Euglena gracilis*, an evolutionarily distant relative of trypanosomatids (Montrichard *et al.*, 1999).

## 2.2. Trypanothione is more than Twice Glutathione

Trypanothione is a much better reductant than glutathione although the redox potentials of the thiols are very similar [−230 to −250 mV for GSH, and −242 mV for T(SH)<sub>2</sub>] (Fairlamb and Cerami, 1992). Trypanothione is a dithiol and formation of an intramolecular disulfide is kinetically favored when compared with the intermolecular oxidation of two molecules of GSH (Gilbert, 1990; Moutiez *et al.*, 1994). Moreover, the positively charged amino group in the spermidine bridge confers to T(SH)<sub>2</sub> a pK value of 7.4 that coincides with the physiological pH (Moutiez *et al.*, 1994). This renders trypanothione highly reactive for thiol-disulfide exchange reactions (Gilbert, 1990).

Trypanothione is involved in many cellular processes. The positively charged dithiol protects DNA from damage generated by radiation-induced radicals (Awad *et al.*, 1992). T(SH)<sub>2</sub> is a potent scavenger of hydrogen peroxide (Carnieri *et al.*, 1993) and is much more efficient than other thiols present in trypanosomatids, i.e. GSH, Gsp and ovoidiol (Ariyanayagam and Fairlamb, 2001). Also, towards peroxynitrite, the reactivity of T(SH)<sub>2</sub> surpasses that of Gsp and GSH (Thomson *et al.*, 2003).

T(SH)<sub>2</sub> reduces protein and non-protein disulfides such as thioredoxin and tryparedoxin (see section 2.3; Reckenfelderbäumer and Krauth-Siegel, 2002; Müller *et al.*, 2003; Schmidt and Krauth-Siegel, 2003), glutathione and ovoidiol (Moutiez *et al.*, 1994; Ariyanayagam and Fairlamb, 2001; Steenkamp, 2002). It is the first natural low molecular mass dithiol shown to directly reduce ribonucleotide reductase (Dormeyer *et al.*, 2001).

T(SH)<sub>2</sub> participates in the resistance mechanisms of these parasites against chemotherapeutic agents as demonstrated for *Leishmania* spp. (Mukhopadhyay



et al., 1996; Grondin et al., 1997; Haimeur et al., 2000; Carter et al., 2003; Wyllie et al., 2004), African trypanosomes (Fairlamb et al., 1989; Shahi et al., 2002), and *T. cruzi* (Repetto et al., 1996; Maya et al., 2003). Recently, a T(SH)<sub>2</sub>/Gsp-S-transferase activity has been associated with the ribosomal elongation factor 1B complex in *C. fasciculata* (Vickers and Fairlamb, 2004) and *L. major* (Vickers et al., 2004a). Moreover, the *L. major* complex catalyzed the direct attack of T(SH)<sub>2</sub> on hydroperoxides (Vickers et al., 2004a). The physiological significance of this T(SH)<sub>2</sub>-S-transferase/oxidase activity remains to be elucidated.

In nearly all organisms, methylglyoxal is detoxified by the GSH-dependent glyoxalase system, composed of glyoxalase I and II. In *L. major* (Vickers et al., 2004b; Ariza et al., 2006) and *L. donovani* (Padmanabhan et al., 2005 and 2006) this system has been shown to use T(SH)<sub>2</sub> as cofactor. *T. brucei* has a trypanothione-dependent glyoxalase II (Irsch and Krauth-Siegel, 2004), but obviously lacks a glyoxalase I gene (Berriman et al., 2005).

### 2.3. The Trypanothione/Tryparedoxin Couple in the Redox Metabolism of Trypanosomatids

Although trypanothione is a potent direct reducing agent of parasite proteins, many of the reactions described in section 2.2 are accelerated by tryparedoxin (TXN) (Fig. 1; Gommel et al., 1997). Based on the primary and tertiary structure, this multipurpose oxidoreductase can be classified as a remote relative of the thioredoxin family of proteins (Flohé et al., 1999). Functionally, TXN shares properties with both thioredoxins and glutaredoxins (Nogoceke et al., 1997; Gommel et al., 1997; Lüdemann et al., 1998; Steinert et al., 2000). The similar redox potentials [ $E^0$  – 249 and –242 mV for TXN and T(SH)<sub>2</sub>, respectively] and their pK values [7.2 and 7.4 for TXN and T(SH)<sub>2</sub>, respectively] close to physiological pH as well as their abundance render the trypanothione/tryparedoxin couple the key factor determining the intracellular redox milieu of the parasites (Reckenfelderbäumer and Krauth-Siegel, 2002). Tryparedoxin is inhibited by trypanothione disulfide which may suggest that tryparedoxin-mediated processes are regulated by the redox status of the cell (Dormeyer et al., 2001).

Together with the discovery of TXN in *C. fasciculata*, the first target for the T(SH)<sub>2</sub>/TXN couple was isolated: a typical 2-Cys-peroxiredoxin that reduces hydroperoxides and thus was termed tryparedoxin peroxidase (TXN-Px) (Nogoceke et al., 1997). Later, these enzymes were also discovered in the pathogenic trypanosomes (Levick et al., 1998; Lopez et al., 2000; Wilkinson et al., 2000b; Barr and Gedamu, 2003; Tetaud et al., 2001; Flohé et al., 2002). The parasite glutathione peroxidase-type enzymes form a second class of tryparedoxin peroxidases (see section 4.1 and Fig. 1; Wilkinson et al., 2002a and 2002c; Hillebrand et al., 2003).

Trypanothione and more efficiently the T(SH)<sub>2</sub>/TXN couple serves as electron source for the biosynthesis of DNA precursors catalyzed by ribonucleotide reductase (Dormeyer et al., 2001). Recently, replication of the unique catenated mitochondrial

DNA (Kinetoplastid DNA) of *C. fasciculata* has been shown to be regulated by the cellular redox potential and to involve the T(SH)<sub>2</sub>/TXN system (Onn *et al.*, 2004). This is the first specific role described for a mitochondrial tryparedoxin (Motyka *et al.*, 2006).

In conclusion, the trypanothione/tryparedoxin couple plays an essential role in many cellular processes and is the most important and efficient system to maintain the cytosolic redox potential in trypanosomatids.

### 3. TRYpanOTHIONE/TRYPAREDOXIN- DEPENDENT 2-CYS-PEROXIREDOXINS (TRYPAREDOXIN PEROXIDASES)

#### 3.1. On the Diversity of Tryparedoxin Peroxidases in Trypanosomatids

All trypanosomatid organisms studied so far possess 2-Cys-peroxiredoxins which show an overall sequence identity of about 55% with the human peroxiredoxins 1 and 2 as well as yeast TSA I (Thiol-Specific Antioxidant). In contrast, 1-Cys-peroxiredoxins could not be detected in the genomes of *T. brucei* (Berriman *et al.*, 2005), *T. cruzi* (El-Sayed *et al.*, 2005), and *L. major* (Ivens *et al.*, 2005). Searching the Kinetoplastid genomes with human peroxiredoxin-6, a typical 1-Cys-peroxiredoxin, revealed the 2-Cys-peroxiredoxins shown in Fig. 2. Functionally, the trypanosomatid 2-Cys-peroxiredoxins act as tryparedoxin peroxidases that reduce hydroperoxides employing the trypanothione/tryparedoxin couple as electron source (Fig. 1; Nogoceke *et al.*, 1997; Flohé *et al.*, 1999). The trypanosomatid genomes encode multiple (nearly) identical copies for cytosolic proteins and on another chromosome a single copy gene for a mitochondrial 2-Cys-peroxiredoxin. The cytosolic enzymes contain the two classical VCP motifs. The other group has an N-terminal mitochondrial pre-sequence and an IPC motif as second redox center. This motif is similar to the LPC sequence in yeast TSA I and II. It is not a general feature of mitochondrial 2-Cys-peroxiredoxins. For instance, the mitochondrial human peroxiredoxin 3 contains two VCP motifs and is more closely related to the cytosolic parasite proteins than to the mitochondrial ones. The overall sequence identity within the cytosolic and mitochondrial proteins, respectively, ranges from 70 to 90%. In contrast, the cytosolic and mitochondrial 2-Cys-peroxiredoxins from a single trypanosomatid organism share only about 50% of all residues. Obviously, the two subfamilies of 2-Cys-peroxiredoxins diverged prior to the separation of the different Kinetoplastida (Castro *et al.*, 2002b). The cellular localisations predicted for the two distinct 2-Cys-peroxiredoxins have been confirmed by immunofluorescence and immunoelectron microscopy in *T. cruzi* (Wilkinson *et al.*, 2000b), *T. brucei* (Tetaud *et al.*, 2001) as well as *L. infantum* (Castro *et al.*, 2002b).

Mammalian, plant and yeast 2-Cys-peroxiredoxins are sensitive to irreversible over-oxidation of the peroxidatic cysteine residue of the first VCP motif to a sulfinic acid (Rhee *et al.*, 2005). Bacterial proteins are much more robust and it has been inferred that the exquisite sensitivity to inactivation is a property of peroxiredoxins that have been selected for in organisms using peroxide for signaling

```
c Tb (#AF326293) -----MSCGDAKLNHPAPHFNEVA 19
c Tc (#CAA09922) -----MSCGDAKLNHPAPDFNETA 19
c Ld (#AF225212) -----MSCGNAKINCPAPPFEEVA 19
c Lm (#AF044679) -----MSCGNAKINSFAPSFEVEA 19
c Cf (#AF020947) -----MSCGAAKLNHPAPEFDMDA 19
m Tb (#AF196570) MLRRFMSLPLSGGIARRSFFRTAPLNLNDYQAYRTATVREAAPEFAGKA 49
m Tc (#AJ006226) MFRRMVAVTSLQKLSRR AFCNTLRLNLNDYQAYKTATVREAAPEWAGKA 49
m Lm (F23.0040chr23) MLRRLSTSSFLKRAQFRGFAATSPLNLNDYQMYRTATVREAAPEQFSGQA 49
m Li (#AY058209) MLRRLPTSCFLKRSQFRGFAATSP LLNLNDYQMYRTATVREAAPEQFSGQA 49
c Sc (TSAI; #P34760) -----MVAQVQKQAPTFFKKA 16
Sp (TPx; #AF083335) -----MSLQIGKPADDFKGT A 16
Hs1 (NKEF A; #L19184) -----MSSGNAKIGHPANFKTA 16
m Hs3 (#P30048) AALRPAACGRTSLTNLLCSGSSQAKLFSTSSSC HAPAVTQHAPYFKGTA 79
St (AhpC; #0A251) -----MSLINTKIKPFKNQA 15

c Tb LMPNGTFKKVDLASYRGKWVLLFFYP LDFTFVCPTEICQFSDRVKEFNDVDVEVIACSMDS 80
c Tc LMPNGTFKKVLATSYK GKWLVLFYPMDFTFVCPTEICQFSDRVKEFSDIGCEVLACSMDS 80
c Ld LMPNGSFKKISLAAYK GKWVLLFFYP LDFTFVCPTEIIAFSENVSRFNFELNCEVLACSMDS 80
c Lm LMPNGSFKKISLSSYK GKWVLLFFYP LDFSFVCPTEVI AFSDSVSRFNFELNCEVLACSIDS 80
c Cf LMPNGTFKKVLSLSSYK GKYVVLLFFYP LDFTFVCPTEIIQFSDDAKRFAEINTEVISCSDS 80
m Tb VV-DGKIKDISMNDYK GKYIVLFFYP LDFTFVCPTEIVSFSDSHAEFEKLN TQVIVASGDS 109
m Tc VV-NGKIQDISLNDYK GKYVVLFFYP LDFTFVCPTEITAFSDAQAEFEDKINTQVIVASGDS 109
m Lm VV-NGAIKIDINMNDYK GKYIVLFFYP LDFTFVCPTEIIAFSDRHADF EKLN TQVIVASGDS 109
m Li VV-NGAIKIDINMNDYK GKYIVLFFYP LDFTFVCPTEIIAFSDRHADF EKLN TQVIVASGDS 109
c Sc VV-DGVFDEVSLD DKYGKYVVLF AFIPLAF TFVCPTEIIAFSEAAKFFEEQGAVLFASTDS 76
Sp VV-NGAFEEIKLADYK GKWVLLGFYP LDFTFVCPTEIVAFSEAAKFAERNAQVILTSTDS 76
Hs1 VMPDQFKDISLSDYK GKYVVFFYP LDFTFVCPTEIIAFSDRAEEFKNLN TQVIVASVDS 80
m Hs3 VV-NGEFKLSLDDDFKGYLVLFYP LDFTFVCPTEIIAFSDKANEHFDVNEC VIVASVDS 136
St FK-NGEFIEVTEK DTEGRWSVFFYP ADTFVCPTEELGDVADHYEELQ LGLGVDVVSVSTDT 75

c Tb EFSHLAWNTVPRKKGGLGT MNIP ILADKTKS IMKAYGVLKEEDGVAYRGLFI IDPQNLRQ 141
c Tc EYSHLAWTS IPRKRGGLQGMNIP ILADKTKC IMKSYGVLKEEDGVAYRGLFI IDPQNLRQ 141
c Ld EYAHLQWTLQDRKKGGLGAMAI PMLADKTKS IARAYGVLEEQQGVAYRGLFI IDPNGMVRQ 141
c Lm EYAHLQWTLQDRKKGGLGTMAI PMLADKTKS IARSYGVLEESQGVAYRGLFI IDPHGMLRQ 141
c Cf EYSHLQWTSVDRKKGGLGPMAI PMLADKTG IARAYGVLDEDSGVAYRGLFI IDPNGKLRQ 141
m Tb HFHSHLAWVETPRKKGGLGEMKI PLSDF TKEISR DYGVLEEQQGLSRLALFVIDDKGILRH 170
m Tc QYSHLAWINTPRKKGGLGEMSI PVLSDLTKE IARDYGV LIEEQQGISLRGLFI IDDKGILRH 170
m Lm VYSHLAWVNTPRKKGGLGEMH I PVLADKSMEI ARDYGV LIEESGIALRGLFI IDDKGILRH 170
m Li VYSHLAWVNTPRKKGGLGEMH I PVLADKSMEI ARDYGV LIEESGIALRGLFI IDDKGILRH 170
c Sc EYSL L AWNTI PRKEGGLGP INI PLLADT N HSLSRDYGV LIEE GVALRGLFI IDPKGVIRH 137
Sp EYSHLAFINTPRKEGGLGGINI PLLADP SHKVS RDYGV LI EDAGVAFRGLFLIDPKGVLRQ 137
Hs1 HFCHLAWNTPKKGGLGPMN I PLVSDPKRTI AQDYGV LKAD EGISFRGLFI IDDKGILRH 141
m Hs3 HFHSHLAWINTPRKNGGLGHMNI ALLSDLTQISR DYGV LEEGSGLALRGLFI IDPNGV LKH 197
St HFTHKAWHSSSE---TIAK I KYAMIGDP T GALTRNFNDMREDEGLADRAT FVVD PQGIQA 133

c Tb ITINDLPVGRNVDELRLVLKAFQFVEKH-GEVCPANWKP GSKTMKADPN GSQD-YFESMNN- 199
c Tc ITVNDLPVGRVD EALRLVLKAFQFVEKH-GEVCPANWKP GDKT MKPDP EKSK E-YFGAVA- 199
c Ld ITVNDMPVGRNVEEVLRLLEAFQFVEKH-GEVCPANWKKGAP TMKPEPKASVEGYFSKQ-- 199
c Lm ITVNDMPVGRSVEEVLRLLEAFQFVEKH-GEVCPANWKKGAP TMKPEPNASVEGYFSKQ-- 199
c Cf I IINDMPEIGRNVEEIVRLVEALQFVEEH-GEVCPANWKKGD AKKKEG----- 188
m Tb VTINDLPVGRNVDEVLRVVQAFQYADKT-GDVI PCNWKP GKETMK---VEAAKE-YFEKNL- 226
m Tc ITVNDLPVGRNVEEVLRVVQAFQYVDKN-GDVI PCNWRPGKPTMK---TEKANE-YFEKNA- 226
m Lm STINDLPVGRNVDEALRVLEAFQYADEN-GDAI PCGWKPGQPTLD---TTKAAE-FF EKNM- 226
m Li STINDLPVGRNVDEALRVLEAFQYADEN-GDAI PCGWKPGQPTLD---TTKAGE-FF EKNM- 226
c Sc ITINDLPVGRNVDEALRLVEAFQWTDKN-GTVL PCNWTPGAATIKPTVDSKE-YFEAANK 196
Sp ITINDLPVGRSVEEALRLLD AFQFVEEH-GEVCPANWHKGS DTID---TKNPEK-YFSKH-- 192
Hs1 ITVNDP PCCRSVDETLRLVLKAFQFTDKH-GEVCPAGWKPGSDTIKP DVPKTEK-YFSKQK- 199
m Hs3 LSVN DLPVGRSVEE TLRLVLKAFQYVETH-GEVCPANWTPD SP TIKPSPASAEK-EYFKQVQ 256
St IEVTAEGIGRADSDELRLRIKAAQYVA AHFGEVCPANWKKGEATLALPSLDLVGKI----- 187
```

Figure 2. Multiple sequence alignment of cytosolic (c) and mitochondrial (m) 2-Cys-peroxiredoxins of *T. brucei* (*Tb*), *T. cruzi* (*Tc*), *L. donovani donovani* (*Ld*), *L. major* (*Lm*), *L. donovani infantum* (*Li*), *C. fasciculata* (*Cf*), *Saccharomyces cerevisiae* (*Sc*), *Schizosaccharomyces pombe* (*Sp*), *Homo sapiens* (*Hs*) and *Salmonella typhimurium* (*St*). Accession numbers are given in parentheses. The redox active VCP (IPC) motifs are depicted in white letters on black. Other conserved cysteine residues are shown in bold on darkgrey. The RK(N)K stretch that is involved in interaction withtryparedoxin is highlighted

(Wood *et al.*, 2003). The peroxide sensitivity has been attributed to two structural features occurring in the sensitive but not in the robust 2-Cys-peroxiredoxins. These are a three-residue insertion associated with a conserved GGLG motif (Fig. 2) and an additional helix as C-terminal extension. In human peroxiredoxin 1, this C-terminal helix with its conserved YF motif covers the peroxidatic active site Cys as well as the loop containing the GGLG motif. The resulting stabilization of a fully folded conformation in sensitive 2-Cys-peroxiredoxins can explain their sensitivity to over-oxidation (Wood *et al.*, 2003). The tryparedoxin peroxidases possess both motifs (in the mitochondrial proteins the second motif is either YF or FF) except for the cytosolic *C. fasciculata* and *L. d. chagasi* I (Acc. N° AF134161) proteins that lack the C-terminal extension. It remains to be elucidated if the rapid inactivation of the *L. donovani* (Flohé *et al.*, 2002) and *T. brucei* 2-Cys-peroxiredoxins (Budde *et al.*, 2003a) is caused by the over-oxidation of the peroxidatic Cys and if this is related to specific residues in their C-terminal tail. So far nothing is known about a potential redox signaling in the parasites, and sulfiredoxins that catalyse the reduction of over-oxidized peroxiredoxins (Biteau *et al.*, 2003) are not detectable in any of the three complete Trypanosomatid genomes (unpublished observation).

The human 2-Cys peroxiredoxins I to IV can be phosphorylated at Thr90 which, in the case of peroxiredoxin I, causes a lowering of the peroxidase activity by 80%. The residue is part of a TPKK consensus site for phosphorylation by cyclin-dependent kinases (Chang *et al.*, 2002). Interestingly, all mitochondrial but not the cytosolic trypanosomatid peroxidases possess this threonine embedded in a very similar motif (Fig. 2).

Site-directed mutagenesis of the 2-Cys-peroxiredoxins from *C. fasciculata* and *L. donovani* showed that Tyr44, Thr49, Cys52, Trp87, Arg128, Cys173, and Trp177 are either directly involved in catalysis or stabilize the protein (Montemartini *et al.*, 1999; Flohé *et al.*, 2002; see section 3.3). Besides the catalytic Cys52-Cys173' couple, the trypanosomatid 2-Cys-peroxiredoxins contain several other conserved cysteine residues the function of which has not yet been addressed. These are Cys3, Cys71, and Cys76 in the cytosolic proteins and Cys107 in the mitochondrial ones (Fig. 2).

The direct reductant of the trypanosomatid 2-Cys-peroxiredoxins is the dithiol protein tryparedoxin. Five basic residues in the C-terminal part of the *C. fasciculata* peroxidase together with Arg92, Lys93, and Lys94 have been supposed to interact with an acidic patch on the surface of tryparedoxin (Alphey *et al.*, 2000). In contrast to the C-terminal basic residues, the RKK stretch is conserved in all trypanosomatid 2-Cys peroxiredoxins (except for the mitochondrial *T. cruzi* protein with an RNK motif; see Fig. 2). Molecular modeling approaches suggested that the RKK cluster is neutralized by Glu76, Asp77, Asp80 of tryparedoxin, and Glu171' of the second



in white on grey. The GGLG and YF motifs involved in the sensitivity of eukaryotic 2-Cys-peroxiredoxins to overoxidation are displayed on light grey background

subunit of the homo-dimeric peroxidase interacts with Arg129 of tryparedoxin (Flohé *et al.*, 2002). Such multiple electrostatic interactions could support the association of the two proteins and would be a distinct feature of the parasite system, since thioredoxins do not have such an acidic patch near the active site (Alphey *et al.*, 1999; Alphey *et al.*, 2003). Nevertheless, with *E. coli* thioredoxin as reducing substrate, *T. brucei* peroxiredoxin still has 19% of the activity observed with *T. brucei* H<sub>6</sub>-tryparedoxin (Budde *et al.*, 2003a).

### 3.2. Specificity and Efficiency of the Tryparedoxin Peroxidases

For nearly all parasite 2-Cys-peroxiredoxins, hydrogen peroxide is the preferred substrate but the more hydrophobic *t*-butyl and cumene hydroperoxides are also accepted. With the cytosolic *T. brucei* and *L. donovani* 2-Cys-peroxiredoxins as well as the mitochondrial *L. infantum* enzyme, linoleic acid hydroperoxide and phosphatidylcholine hydroperoxide have been investigated as potential physiological substrates. All three enzymes have relatively low activities with the lipid-derived compounds, or are even inactivated in a time-dependent reaction (Flohé *et al.*, 2002; Castro *et al.*, 2002a; Budde *et al.*, 2003a). Thus, the parasite tryparedoxin peroxidases do not appear to play a major role in the removal of oxidatively damaged lipids but probably act in the lowering or sensing of the cellular hydrogen peroxide levels.

The tryparedoxin peroxidases catalyze the reduction of peroxynitrite (ONOO<sup>-</sup>) (Trujillo *et al.*, 2004; see also Chapter 5). Whereas T(SH)<sub>2</sub> and tryparedoxin react with ONOO<sup>-</sup> at rates that are within the range of typical thiols ( $7.2 \times 10^3$  and  $3.5 \times 10^3 \text{ M}^{-1}\text{s}^{-1}$ , respectively), the *T. brucei* and *T. cruzi* tryparedoxin peroxidases reduce peroxynitrite with second order rate constants of  $9 \times 10^5 \text{ M}^{-1}\text{s}^{-1}$  and  $7.2 \times 10^5 \text{ M}^{-1}\text{s}^{-1}$ , respectively. In addition, the peroxidases inhibit other fast peroxynitrite-mediated processes (Trujillo *et al.*, 2004). Cys52 that is essential for hydroperoxide reduction (Flohé *et al.*, 2002) is also crucial for peroxynitrite reduction. For the cytosolic tryparedoxin peroxidase from *L. chagasi* it has been reported that Cys52 is essential for H<sub>2</sub>O<sub>2</sub> detoxification whereas Cys173 is crucial for peroxynitrite reduction (Barr and Gedamu, 2003). The discrepancy between the homologous trypanosomal and leishmanial enzymes deserves further investigation.

As will be outlined in section 3.3, the tryparedoxin peroxidases follow a ping-pong mechanism with limiting or infinite kinetic constants (see also Chapter 5). In the cases where saturation kinetics are observed, the K<sub>m</sub>-values for *t*-butyl hydroperoxide and tryparedoxin vary between 0.3 and 52 μM and between 1.7 and 32 μM, respectively (Guerrero *et al.*, 2000; Flohé *et al.*, 2002; Castro *et al.*, 2002a; Budde *et al.*, 2003a). The second order rate constants for the reduction of hydroperoxides or peroxynitrite are in the range of  $3 \times 10^4$  to  $1.7 \times 10^7 \text{ M}^{-1}\text{s}^{-1}$  (Guerrero *et al.*, 2000; Flohé *et al.*, 2002; Budde *et al.*, 2003a; Trujillo *et al.*, 2004). The second half reaction, namely the trypanothione/tryparedoxin-dependent reduction of the oxidized enzyme, occurs at rate constants that are usually one order

of magnitude higher ( $10^6$  to  $10^7$   $M^{-1}s^{-1}$ ; Nogoceke *et al.*, 1997; Montemartini *et al.*, 1998; Guerrero *et al.*, 2000; Flohé *et al.*, 2002; Castro *et al.*, 2002a; Budde *et al.*, 2003a). Thus, reduction of the hydroperoxide substrate and not regeneration of the reduced peroxidase is rate determining. Compared to the classical mammalian glutathione peroxidases (Flohé *et al.*, 1972), reduction of the hydroperoxides by the tryparedoxin peroxidases is one to two orders of magnitude slower (Nogoceke *et al.*, 1997). The parasite detoxification system depends on the  $T(SH)_2$  concentration since the overall rate-limiting step is the regeneration of reduced tryparedoxin by  $T(SH)_2$  (Fig. 1). As shown for the *C. fasciculata* system, the rate constant for the reduction of tryparedoxin is  $10^4$   $M^{-1}s^{-1}$  and thus lower than any of the rate constants of the tryparedoxin peroxidase reaction (Gommel *et al.*, 1997). At high concentrations of  $T(SH)_2$  and hydroperoxide, the spontaneous reaction becomes significant (Carnieri *et al.*, 1993; Dormeyer *et al.*, 2001). On the other hand, the cellular concentrations of tryparedoxin peroxidase as well as of tryparedoxin are very high. In *C. fasciculata* the proteins have been estimated to amount to 6% and 5% of the total soluble protein, respectively, which may compensate for their low molecular efficiency (Nogoceke *et al.*, 1997). It is tempting to speculate that the parasite peroxidases have (additional) roles distinct from the direct removal of hydroperoxides. In *S. pombe*, the 2-Cys-peroxiredoxin Tpx1 functions as activator of Pap1 that regulates transcription of antioxidant genes in response to  $H_2O_2$  (Vivancos *et al.*, 2005).

### 3.3. Catalytic Mechanism of the Trypanosomatid 2-Cys-peroxiredoxins

The 2-Cys-peroxiredoxins of Trypanosomatids function as terminal peroxidases of a complex redox cascade that reduces hydroperoxides with NADPH as final electron source (Fig. 1). The catalyzed reaction can be subdivided into two parts. The first step is the reduction of the hydroperoxide (ROOH) by reduced tryparedoxin peroxidase (TXNPx) with the concomitant oxidation of the enzyme. The second half-reaction represents the restoration of the reduced enzyme by the dithiol protein tryparedoxin (TXN):

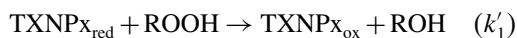

The first tryparedoxin peroxidase for which the kinetic mechanism has been studied in detail was the protein isolated from *C. fasciculata*. The enzyme showed a ping-pong mechanism with infinite velocity and Michaelis constants (Nogoceke *et al.*, 1997). This kinetic pattern corresponds to that of the chemically unrelated selenocysteine-containing mammalian glutathione peroxidases (Flohé *et al.*, 1972; Flohé and Brigelius-Flohé, 2001; see also Chapter 5) as well as the glutathione peroxidase-type tryparedoxin peroxidase of *T. brucei* (Hillebrand *et al.*, 2003; Schlecker *et al.*, 2005) (see section 4.1). In contrast, the recombinant 2-Cys-peroxiredoxins from *T. cruzi* and *L. donovani* yielded limiting  $K_m$ - and  $V_{max}$ -values

(Guerrero *et al.*, 2000; Flohé *et al.*, 2002). In the case of the *L. infantum* and *T. brucei* peroxidases, the double reciprocal plots did not have constant slopes over the whole range of hydroperoxide concentrations and the slopes at the lowest tryparedoxin concentrations did not perfectly run in parallel (Castro *et al.*, 2002a; Budde *et al.*, 2003a). Substrate-induced conformational changes that modulate the affinity of the cosubstrate tryparedoxin and lead to negative cooperativity between reaction centers within the oligomeric enzyme were postulated to account for these deviations (Budde *et al.*, 2003a; see section 3.4 and Chapter 5).

A first insight in the residues involved in catalysis was obtained by mutational studies of the *C. fasciculata* 2-Cys-peroxiredoxin. C52S, W87D and R128E variants proved to be inactive, a Q164E mutant was fully active, and C173S, W87H, W177E, and W177H showed reduced activity. From these data, it was concluded that the active site Cys52 is primarily activated to the thiolate form by Arg128 (and possibly by Trp87) which then reacts with the hydroperoxide substrate and is oxidized to a sulfenic acid (Montemartini *et al.*, 1999). Extended site-directed mutagenesis and modeling studies on the 2-Cys-peroxiredoxin from *L. donovani* confirmed the essential role of Cys52 and Arg128 and revealed that Trp87 is not directly involved in catalysis. Instead, Trp87 as well as Tyr44 play crucial roles for the structural stability of the protein (Flohé *et al.*, 2002).

A model of the reduced *L. donovani* peroxidase based on the structure of human peroxiredoxin 2 (Schröder *et al.*, 2000) suggested that Thr49 of the TXXC active site motif forms an almost ideal hydrogen bridge with the sulfur of Cys52. Exchange of Thr49 by a serine resulted in an enzyme species that was even more active than the authentic protein, whereas the respective valine mutant showed less than 1% of wild type activity (Flohé *et al.*, 2002). These data led to the proposal of a modified reaction mechanism where Cys52 builds the center of a novel catalytic triad. By hydrogen bonding to the hydroxyl side chain of Thr49 and by the positive charge of Arg128 the solvent exposed thiol of Cys52 becomes deprotonated. In the first half reaction, the thiolate anion of Cys52 reacts with the hydroperoxide substrate leading to the reduction of the substrate and formation of a sulfenic acid residue at Cys52 (Flohé *et al.*, 2002; see also Chapters 3, 4 and 5). Cys173' supported by Trp177' then attacks the oxidized sulfur of Cys52 generating a head-to-tail oriented covalently linked homodimer. In this disulfide bridge the sulfur of Cys52 is inaccessible for tryparedoxin, while Cys173' is exposed to the solvent. Regeneration of the reduced peroxidase, this means the second half-reaction, is initiated by the attack of the N-terminal Cys (Cys40 in *C. fasciculata* tryparedoxin 1 and *T. brucei* tryparedoxin) of the CPPC active site motif of tryparedoxins. The resulting protein mixed-disulfide is then attacked by Cys43 of tryparedoxin releasing oxidized tryparedoxin and reduced peroxidase. The intermolecular disulfide bridge was generated as stable reaction product by co-oxidation of the *T. brucei* peroxidase with the C43S mutant of *T. brucei* tryparedoxin (Budde *et al.*, 2003a; Budde *et al.*, 2003b). Theoretically, this process could occur twice within a single peroxidase dimer and electron microscopy data strongly support a 1:1 stoichiometry (Budde *et al.*, 2003a). In

contrast, molecular modeling studies on the *C. fasciculata* 2-Cys-peroxiredoxin suggested that a single tryparedoxin interacts with a peroxidase dimer (Alphey *et al.*, 2000).

### 3.4. Three-dimensional Structures of Tryparedoxin Peroxidases

The crystal structures of the 2-Cys-peroxiredoxins from *C. fasciculata* (Alphey *et al.*, 2000) and *T. cruzi* (Pineyro *et al.*, 2005) have been solved at 3.2 Å and 2.8 Å resolution, respectively (for comparison with other Prx structures see also Chapter 3). The structures of the reduced proteins comprise ten subunits that form a decamer composed of five homodimers. In each monomer the first 169 residues show the thioredoxin super-family fold and the remaining residues (170 to 199 in the *T. cruzi* peroxidase) form a C-terminal tail that folds in loops and terminates with a short helix. In the *C. fasciculata* protein, this C-terminal part is eleven residues shorter which may be the reason for some discrepancies between the two structures. Although both proteins were crystallized under reducing conditions, only the *T. cruzi* peroxidase showed all ten catalytic cysteines in the reduced state. In the *C. fasciculata* enzyme, in three monomers the active site (Cp) loop (residues 46–50) was in the conformation expected for the reduced enzyme, three monomers structurally corresponded to the oxidized enzyme and four represented an intermediate state. Probably the particularly short C-terminal tail of the *C. fasciculata* peroxidase – which is similar to those of prokaryotic 2-Cys-peroxiredoxins – is responsible for the observed multiple conformations of the Cp loop.

Tryparedoxin peroxidases form stable dimers that are detectable by SDS- PAGE even under reducing conditions as has been observed for other 2-Cys- peroxiredoxins. Cys52, the residue directly responsible for peroxidase activity (N-proximal Cys, peroxidative Cys) is positioned near the monomer-monomer interface in a narrow solvent-accessible pocket at the N-terminus of helix  $\alpha 1$ . In the structure of the *T. cruzi* peroxidase, the thiol group of Cys52 is in hydrogen bonding distance to the side chain oxygen and nitrogen of Thr49 and Arg128, respectively (Pineyro *et al.*, 2005) which is in full agreement with previous mutational (Montemartini *et al.*, 1999) and modeling studies (Hofmann *et al.*, 2002; Flohé *et al.*, 2002; Fig. 3). These interactions were predicted to stabilize the thiolate anion form of Cys52, lower its pK value, and increase its reactivity. Both residues are essential for catalysis (Flohé *et al.*, 2002; see section 3.3). In the structure of the *C. fasciculata* peroxidase, the arrangement is slightly different. Cys52 also accepts a hydrogen bond from Arg128 but no direct interaction with Thr49 has been observed. Instead, a water molecule occupies the active site with hydrogen bonding interactions to the carbonyl of Cys52 and the side chains of Arg128 and Thr49 (Alphey *et al.*, 2000).

Cys173' (C-proximal Cys, resolving Cys) in the other subunit of the homodimer - that forms an intermolecular disulfide bridge with Cys52 during catalysis – is located in a loop following the last helix of the thioredoxin fold in a hydrophobic environment formed by Ala162', Phe165', Trp177', and Thr183' in the *T. cruzi* peroxidase (Pineyro *et al.*, 2005). Protection of the resolving cysteine from



solvent, and thus from oxidation, is probably crucial for the catalytic efficiency as indicated by the drastically diminished activity of W117H and W177E mutants of the *C. fasciculata* peroxidase (Montemartini *et al.*, 1999).

In the crystal structure of the reduced peroxidase, Cys52 and Cys173' are 10 Å apart. Thus local unfolding of the active site as well as the C-terminal tail is necessary to allow disulfide bond formation. In this process the interaction between Cys52 and Thr49 probably plays a key role. Once Cys52 has been oxidized to a sulfenic acid, interaction with the oxygen of Thr49 is no longer possible whereas the guanidyl group of Arg128 stabilizes the position of the oxidized cysteine. The new electrostatic environment of the active site may lead to the movement of Thr49. This would propagate to neighbouring residues causing a conformational change in both the 44–49 loop and the N-terminal part of helix  $\alpha$ 1, as it is observed in the structures of oxidized 2-Cys-peroxiredoxins (Pineyro *et al.*, 2005). The adjacent Phe50 is the main contributor to the homodimer interface in all typical 2-Cys-peroxiredoxins. The aromatic residue interacts almost exclusively with residues in the C-terminal arm of the adjacent subunit of the homodimer (Fig. 3). Movement of Phe50 would destabilize the C-terminal arm providing space for the 44–49 loop in its new conformation.

The crystal structures of the reduced parasite peroxidases revealed decamers, as has also been observed in human thioredoxin peroxidase (2-Cys-peroxiredoxin 2; TPx-B) which was crystallized in an over-oxidized state with the active site cysteine as sulfinic acid (Schröder *et al.*, 2000). In contrast, the crystals of oxidized

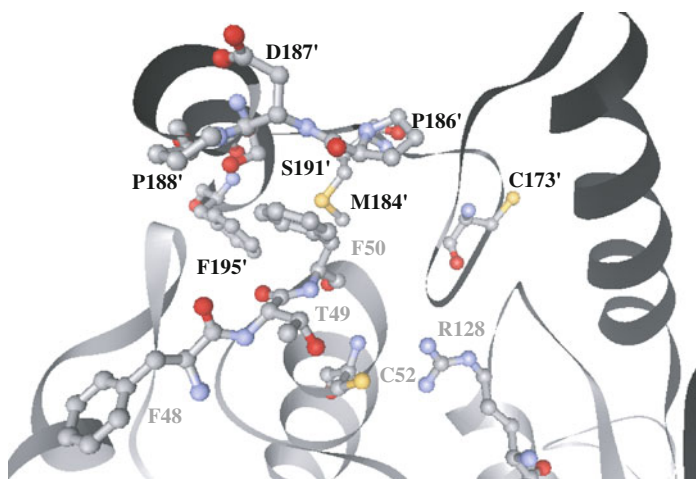

**Figure 3.** Active site of *T. cruzi* TXNPx derived from the structure of the reduced protein. One subunit of the homodimer is depicted in grey, the other one in black with primed residues. Residues that are involved in catalysis and/or subunit interaction (see section 3.4) are shown in ball and stick models. The carbon, oxygen, nitrogen and sulfur atoms are displayed in grey, red, blue and yellow, respectively. The 3-D model was generated from Protein Data Bank entry 1UUL (Pineyro *et al.*, 2005) using the program 3D-Mol (Invitrogen) (See Plate 18)

2-Cys-peroxiredoxins, like that of the rat heme-binding protein 23 (2-Cys-peroxiredoxin 1, HBP23; Hirotsu *et al.*, 1999), contain homodimers in the asymmetric unit. It was supposed that 2-Cys-peroxiredoxins undergo conformational changes during catalysis and that these alterations influence the quaternary state. It was also suggested that formation of a decamer could reduce the propensity for indiscriminate oligomerisation thereby maintaining 2-Cys-dependent peroxidase activity (Alphey *et al.*, 2000). So far it is not known if a dimer-decamer equilibrium exists *in vivo*. Reduced *T. brucei* tryparedoxin peroxidase elutes from a gel permeation column in a single peak, and electron microscopy of the protein sample shows a mixture of ring-shaped decamers and lower molecular mass open-chain oligomers. The oxidized peroxidase elutes in several peaks starting with high molecular mass aggregates. In the peak with the lowest mass ring-shaped hexamers prevail which are practically indistinguishable from those seen in the reduced enzyme (Budde *et al.*, 2003a). This indicates that the parasite peroxiredoxin does not undergo a dimer to decamer transition upon reduction as has been reported for bacterial AhpC from *S. typhimurium* (Wood *et al.*, 2002).

In the MALDI-TOF spectra of freshly prepared *T. brucei* peroxidase, the most prominent peak had a mass corresponding to a protein dimer. Some minor peaks were consistent with tetra-, hexa- and octameric protein species. This was interpreted to be due to an unusually strong non-covalent dimer-dimer interaction that resists the laser desorption and ionization (Budde *et al.*, 2003a). Interestingly, the primary structures of the trypanosomatid 2-Cys-peroxiredoxins show a Cys residue at position 3 that is not visible in the crystal structures (Alphey *et al.*, 2000; Pineyro *et al.*, 2005). Future work will have to elucidate if Cys3 plays a functional role for the peroxidase and/or may be involved in covalent polymer formation.

### 3.5. The Tryparedoxin Peroxidases are Resistance and Metastasis Factors and are Essential for the Parasites

In two types of *L. amazonensis* cell lines that were selected for arsenite resistance, the cytosolic and mitochondrial tryparedoxin peroxidases are distinctly over-expressed (Lin *et al.*, 2005). In addition, transfectants of different *Leishmania* spp. and *T. cruzi* that over-express either the cytosolic or the mitochondrial 2-Cys-peroxiredoxin show increased resistance to exogenous H<sub>2</sub>O<sub>2</sub> and/or *t*-butyl hydroperoxide (Wilkinson *et al.*, 2000b; Castro *et al.*, 2002b; Lin *et al.*, 2005) or even an enhanced survival of the parasites in macrophages (Barr and Gedamu, 2003).

Parasites of the *L. Viannia* subgenus are major causative agents of mucocutaneous leishmaniasis, a disease characterized by parasite dissemination (metastasis) from the original cutaneous lesion to form debilitating secondary lesions in the nasopharyngeal mucosa. Comparison of the soluble proteome of promastigote clones of *L. (V.) guyanensis* revealed the cytosolic 2-Cys-peroxiredoxin as one of two abundant proteins associated with metastasis. Two cytosolic 2-Cys-peroxiredoxin isoforms with pI-values differing by 0.4 pH units are differentially expressed in metastatic and non-metastatic parasites (Walker *et al.*, 2006). Phosphorylation has

been ruled out as reason for the shift to a more acidic protein in the metastatic parasites. Other possible modifications causing acidification of the protein such as the oxidation of a cysteine residue have not yet been investigated.

In African trypanosomes, RNA interference is a powerful technique to address the biological function of a protein (Ullu *et al.*, 2004). Induction of double-stranded RNA directed against the cytosolic 2-Cys-peroxiredoxin had a dramatic effect on the growth of bloodstream *T. brucei*. The cells showed diminished peroxidase activity and were 16-times more susceptible to exogenous hydrogen peroxide (Wilkinson *et al.*, 2003). In contrast, down-regulation of the mitochondrial 2-Cys-peroxiredoxin did not significantly alter the growth rate and sensitivity against hydrogen peroxide (Wilkinson *et al.*, 2003) although over-expression of the protein conferred increased resistance to exogenous peroxides comparable with the cytosolic peroxidase (Wilkinson *et al.*, 2000b). The effects observed when the cytosolic peroxiredoxin was depleted suggest that the enzyme is responsible for protecting *T. brucei* from hydrogen peroxide. The glutathione peroxidase-type trypanoxin peroxidases (section 4.1) are obviously unable to compensate for the lowered levels of the cytosolic 2-Cys-peroxiredoxin and *vice versa*.

*T. cruzi* and *Leishmania* species probably lack a complete machinery for RNA interference (Ullu *et al.*, 2004). In *L. amazonensis* down-regulation of the cytosolic and mitochondrial 2-Cys-peroxiredoxins by an antisense-RNA approach was accompanied by increased sensitivity of the transfectants to H<sub>2</sub>O<sub>2</sub> and/or to *t*-butyl hydroperoxide (Lin *et al.*, 2005).

## 4. OTHER TRYPANOTHIONE-DEPENDENT PEROXIDASES

### 4.1. Glutathione Peroxidase-type Trypanoxin Peroxidases

All trypanosomatid organisms studied so far possess glutathione peroxidase-type enzymes which differ from the classical mammalian glutathione peroxidases by the replacement of the active site selenocysteine by a cysteine residue. The trypanosomal enzymes are monomers and thus more similar to the monomeric phospholipid hydroperoxide glutathione peroxidase than to the other tetrameric mammalian enzymes. They have very low activity with GSH (Wilkinson *et al.*, 2000a and 2002c; Hillebrand *et al.*, 2003) but act as trypanoxin peroxidases as do the 2-Cys-peroxiredoxins of the parasites (Fig. 1, sections 3.2 and 3.3; Wilkinson *et al.*, 2002a; Hillebrand *et al.*, 2003; Schlecker *et al.*, 2005). Similar specificities of glutathione peroxidase-type proteins for thioredoxins has also been observed in *Plasmodium falciparum* (Sztajer *et al.*, 2001) and other species (Delaunay *et al.*, 2002; Jung *et al.*, 2002; Maiorino *et al.*, 2006).

In *T. cruzi*, glutathione peroxidase I is localized in the cytosol and glycosomes of the parasite (Wilkinson *et al.*, 2002a) and a glutathione peroxidase II occurs in the endoplasmic reticulum (Wilkinson *et al.*, 2002c). In African trypanosomes, the glutathione peroxidase-type enzymes have been detected in the cytosol and mitochondrion of the parasite (Schlecker *et al.*, 2005). Despite 79% overall sequence

identity, *T. cruzi* glutathione peroxidase I and *T. brucei* peroxidase III show significant differences not only with respect to their cellular localization but also in their substrate specificities. *T. cruzi* glutathione peroxidase I catalyses the reduction of different hydrophobic substrates, especially of phospholipid hydroperoxides like phosphatidylcholine hydroperoxide, but not of hydrogen peroxide (Wilkinson *et al.*, 2000a and 2002a). In contrast, for the *T. brucei* peroxidase, hydrogen peroxide, thymine hydroperoxide and linoleic acid hydroperoxide are probable physiological substrates and the enzyme is inactivated by phosphatidylcholine hydroperoxide (Hillebrand *et al.*, 2003; Schlecker *et al.*, 2005).

The cysteine-containing glutathione peroxidases show rate constants for hydroperoxide reduction of  $105 \text{ M}^{-1} \text{ s}^{-1}$  (Hillebrand *et al.*, 2003) which are in the same order of magnitude than those of the 2-Cys-peroxiredoxins (see section 3.2) but significantly lower than those of the mammalian seleno-enzymes ( $> 10^7 \text{ M}^{-1} \text{ s}^{-1}$ ; Flohé *et al.*, 1972; Hofmann *et al.*, 2002; Flohé and Brigelius-Flohé, 2001). Glutathione peroxidases follow a ping-pong-mechanism for two-substrate-reactions without formation of a ternary complex and most of them do not show typical saturation kinetics. This kinetic pattern was also observed for the *T. brucei* glutathione peroxidase-type enzyme (Hillebrand *et al.*, 2003; Schlecker *et al.*, 2005). Site-directed mutagenesis of the *T. brucei* glutathione peroxidase-type enzyme confirmed that the catalytic triad composed of Cys47, Gln82, and Trp137 is essential for catalysis. In addition, Cys95, a residue conserved in the peroxidases of trypanosomes, yeast and plants but not in the mammalian seleno-enzymes, proved to be essential. During catalysis, Cys47 and Cys95 form an intramolecular disulfide bond which is then attacked at Cys95 by Cys40 of *T. brucei* tryparedoxin (Schlecker *et al.*, manuscript in preparation). Such an intramolecular disulfide bond also occurs in atypical 2-Cys-peroxiredoxins as well as in Cys-homologous glutathione peroxidases of yeast and plants (Delaunay *et al.*, 2002; Jung *et al.*, 2002; Tanaka *et al.*, 2005; Maiorino *et al.*, 2006). It is probably the reason for the fact that these enzymes are preferably reduced by dithiol proteins instead of glutathione.

RNA-interference studies revealed that the glutathione peroxidase-type enzymes are essential for both the mammalian and the insect form of *T. brucei* as is the case for the cytosolic 2-Cys-peroxiredoxin in bloodstream parasites (section 3.5; Wilkinson *et al.*, 2003; Schlecker *et al.*, 2005). It is not known why the two types of tryparedoxin peroxidases cannot compensate for each other. Maybe the glutathione peroxidase-type enzymes of *T. brucei* fulfil alternative functions independent of the direct reduction hydroperoxides. Future work will reveal if the parasite glutathione peroxidase-type enzyme can function as specific hydroperoxide sensor transducing a redox signal to downstream protein thiols as it has been shown for yeast Gpx 3 (Delaunay *et al.*, 2002).

#### 4.2. Ascorbate-dependent Peroxidases

In *T. cruzi* (Wilkinson *et al.*, 2002b) and *L. major* (Adak and Datta, 2005), plant-like ascorbate-dependent heme-peroxidases have been described. *T. brucei* does not have

a corresponding gene which is another example for the observation that African trypanosomes have the least metabolic capability of the three trypanosomatid organisms (Berriman *et al.*, 2005). The *T. cruzi* and *L. major* enzymes share 63% of all residues and 30–35% with homologous plant peroxidases. They reduce hydrogen peroxide at the expense of ascorbate, and dehydroascorbate generated upon catalysis is then reduced by the trypanothione/trypanothione reductase system (Fig. 1; Krauth-Siegel and Lüdemann, 1996; Wilkinson *et al.*, 2002b). Over-expression of the ascorbate-dependent peroxidase in *T. cruzi* confers a 2-fold increase in resistance towards hydrogen peroxide (Wilkinson *et al.*, 2002b). The *T. cruzi* enzyme has been localized in the endoplasmic reticulum of the parasite (Wilkinson *et al.*, 2002b). The *L. major* peroxidase contains a putative transmembrane domain. It has been postulated that the protein is anchored in the membrane of different organelles and that the transmembrane domain plays a role for catalysis (Adak and Datta, 2005).

## ACKNOWLEDGEMENTS

Our work is supported by the Deutsche Forschungsgemeinschaft, SFB 544 “Control of Tropical Infectious Diseases”. M. A. C. is a Research Fellow of the Medical Faculty of Heidelberg University.

## REFERENCES

- Adak, S., Datta, A.K., 2005, *Leishmania major* encodes an unusual peroxidase that is a close homologue of plant ascorbate peroxidase: a novel role of the transmembrane domain. *Biochem. J.* **390**: 465–474.
- Alphey, M.S., Leonard, G.A., Gourley, D.G., Tetaud, E., Fairlamb, A.H., Hunter, W.N., 1999, The high resolution crystal structure of recombinant *Crithidia fasciculata* tryparedoxin-I. *J. Biol. Chem.* **274**: 25613–25622.
- Alphey, M.S., Bond, C.S., Tetaud, E., Fairlamb, A.H., Hunter, W.N., 2000, The structure of reduced tryparedoxin peroxidase reveals a decamer and insight into reactivity of 2 Cys-peroxiredoxins. *J. Mol. Biol.* **300**: 903–916.
- Alphey, M.S., Gabrielsen, M., Micossi, E., Leonard, G.A., McSweeney, S.M., Ravelli, R.B., Tetaud, E., Fairlamb, A.H., Bond, C.S., Hunter, W.N., 2003, Tryparedoxins from *Crithidia fasciculata* and *Trypanosoma brucei*: photoreduction of the redox disulfide using synchrotron radiation and evidence for a conformational switch implicated in function. *J. Biol. Chem.* **278**: 25919–25925.
- Ariyanayagam, M.R., Fairlamb, A.H., 1999, *Entamoeba histolytica* lacks trypanothione metabolism. *Mol. Biochem. Parasitol.* **103**: 61–69.
- Ariyanayagam, M.R., Fairlamb, A.H., 2001, Ovothioid and trypanothione as antioxidants in trypanosomatids. *Mol. Biochem. Parasitol.* **115**: 189–198.
- Ariyanayagam, M.R., Oza, S.L., Guther, M.L., Fairlamb, A.H., 2005, Phenotypic analysis of trypanothione synthetase knockdown in the African trypanosome. *Biochem. J.* **391**: 425–432.
- Ariza, A., Vickers, T. J., Greig, N., Armour, K. A., Dixon, M. J., Eggleston, I. M., Fairlamb, A. H., Bond, C. S., 2006, Specificity of the trypanothione-dependent *Leishmania major* glyoxalase I: structure and biochemical comparison with the human enzyme. *Mol. Microbiol.* **59**: 1239–1248.
- Awad, S., Henderson, G. B., Cerami, A., Held, K. D., 1992, Effects of trypanothione on the biological activity of irradiated transforming DNA. *Int. J. Radiat. Biol.* **62**: 401–407.
- Barr, S. D., and Gedamu, L., 2003, Role of peroxidoxins in *Leishmania chagasi* survival. Evidence of an enzymatic defense against nitrosative stress. *J. Biol. Chem.* **278**: 10816–10823.

- Berriman, M., Ghedin, E., Hertz-Fowler, C., Blandin, G., Renauld, H., Bartholomeu, D.C., et al., 2005, The genome of the African trypanosome *Trypanosoma brucei*. *Science* **309**: 416–422.
- Biteau, B., Labarre, J., Toledano, M.B., 2003, ATP-dependent reduction of cysteine-sulphinic acid by *S. cerevisiae* sulphiredoxin. *Nature* **425**: 980–984.
- Bollinger, J.M., Kwon, D.S., Huisman, G.W., Kolters, R., Walsh, C.T., 1995, Glutathionylspermidine metabolism in *Escherichia coli*. Purification, cloning, overproduction, and characterization of a bifunctional glutathionylspermidine synthetase/amidase. *J. Biol. Chem.* **270**: 14031–14041.
- Budde, H., Flohé, L., Hecht, H.J., Hofmann, B., Stehr, M., Wissing, J., Lünsdorf, H., 2003a, Kinetics and redox-sensitive oligomerisation reveal negative subunit cooperativity in tryparedoxin peroxidase of *Trypanosoma brucei brucei*. *Biol. Chem.* **384**: 619–633.
- Budde, H., Flohé, L., Hofmann, B., Nimtz, M., 2003b, Verification of the interaction of a tryparedoxin peroxidase with tryparedoxin by ESI-MS/MS. *Biol. Chem.* **384**: 1305–1309.
- Carnieri, E.G., Moreno, S.N., Docampo, R., 1993, Trypanothione-dependent peroxide metabolism in *Trypanosoma cruzi* different stages. *Mol. Biochem. Parasitol.* **61**: 79–86.
- Carter, K.C., Sundar, S., Spickett, C., Pereira, O.C., Mullen, A.B., 2003, The in vivo susceptibility of *Leishmania donovani* to sodium stibogluconate is drug specific and can be reversed by inhibiting glutathione biosynthesis. *Antimicrob. Agents Chemother.* **47**: 1529–1535.
- Castro, H., Budde, H., Flohé, L., Hofmann, B., Lünsdorf, H., Wissing, J., Tomas, A.M., 2002a, Specificity and kinetics of a mitochondrial peroxiredoxin of *Leishmania infantum*. *Free Radic. Biol. Med.* **33**: 1563–1574.
- Castro, H., Sousa, C., Santos, M., Cordeiro-da-Silva, A., Flohé, L., Tomas, A.M., 2002b, Complementary antioxidant defense by cytoplasmic and mitochondrial peroxiredoxins in *Leishmania infantum*. *Free Radic. Biol. Med.* **33**: 1552–1562.
- Chang, T.S., Jeong, W., Choi, S.Y., Yu, S., Kang, S.W., Rhee, S.G., 2002, Regulation of peroxiredoxin I activity by Cdc2-mediated phosphorylation. *J. Biol. Chem.* **277**: 25370–25376.
- Comini, M., Menge, U., and Flohé, L., 2003, Biosynthesis of trypanothione in *Trypanosoma brucei brucei*. *Biol. Chem.* **384**: 653–656.
- Comini, M.A., Guerrero, S.A., Haile, S., Menge, U., Lünsdorf, H., Flohé, L., 2004, Validation of *Trypanosoma brucei* trypanothione synthetase as drug target. *Free Radic. Biol. Med.* **36**: 1289–1302.
- Comini, M., Menge, U., Wissing, J., Flohé, L., 2005, Trypanothione synthesis in crithidia revisited. *J. Biol. Chem.* **280**: 6850–6860.
- Delaunay, A., Pflieger, D., Barrault, M.B., Vinh, J., Toledano, M.B., 2002, A thiol peroxidase is an H<sub>2</sub>O<sub>2</sub> receptor and redox-transducer in gene activation. *Cell* **111**: 471–481.
- Dormeyer, M., Reckenfelderbäumer, N., Lüdemann, H., Krauth-Siegel, R.L., 2001, Trypanothione-dependent synthesis of deoxyribonucleotides by *Trypanosoma brucei* ribonucleotide reductase. *J. Biol. Chem.* **276**: 10602–10606.
- El-Sayed, N.M., Myler, P.J., Bartholomeu, D.C., Nilsson, D., Aggarwal, G., et al., 2005, The genome sequence of *Trypanosoma cruzi*, etiologic agent of Chagas disease. *Science* **309**: 409–415.
- Fairlamb, A.H., Blackburn, P., Ulrich, P., Chait, B.T., Cerami, A., 1985, Trypanothione: a novel bis(glutathionyl)spermidine cofactor for glutathione reductase in trypanosomatids. *Science* **227**: 1485–1487.
- Fairlamb, A.H., Henderson, G.B., Cerami, A., 1989, Trypanothione is the primary target for arsenical drugs against African trypanosomes. *Proc. Natl. Acad. Sci. USA* **86**: 2607–2611.
- Fairlamb, A.H., Cerami, A., 1992, Metabolism and functions of trypanothione in the Kinetoplastida. *Annu. Rev. Microbiol.* **46**: 695–729.
- Flohé L., Brigelius-Flohé R., 2001, Selenoproteins of the glutathione system. In: L. Hatfield (ed.), Selenium, its Molecular Biology and Role in Human Health, Kluwer Academic Publishers, Boston, Dordrecht, London, pp.157–178.
- Flohé, L., Loschen, G., Günzler, W.A., Eichele, E., 1972, Glutathione peroxidase, V. The kinetic mechanism. *Hoppe Seylers Z. Physiol. Chem.* **353**: 987–999.
- Flohé, L., Hecht, H.J., Steinert, P., 1999, Glutathione and trypanothione in parasitic hydroperoxide metabolism. *Free Radic. Biol. Med.* **27**: 966–984.

- Flohé, L., Budde, H., Bruns, K., Castro, H., Clos, J., Hofmann, B., Kansal-Kalavar, S., Krumme, D., Menge, U., Plank-Schumacher, K., Sztajer, H., Wissing, J., Wylegalla, C., Hecht, H.J., 2002, Tryparedoxin peroxidase of *Leishmania donovani*: molecular cloning, heterologous expression, specificity, and catalytic mechanism. *Arch. Biochem. Biophys.* **397**: 324–335.
- Gilbert, H.F., 1990, Molecular and cellular aspects of thiol-disulfide exchange. *Adv. Enzymol. Relat. Areas Mol. Biol.* **63**: 69–172.
- Gommel, D.U., Nogoceke, E., Morr, M., Kiess, M., Kalisz, H.M., Flohé, L., 1997, Catalytic characteristics of tryparedoxin. *Eur. J. Biochem.* **248**: 913–918.
- Grondin, K., Haimeur, A., Mukhopadhyay, R., Rosen, B.P., Ouellette, M., 1997, Co-amplification of the gamma-glutamylcysteine synthetase gene *gsh1* and of the ABC transporter gene *pgpA* in arsenite-resistant *Leishmania tarentolae*. *Embo J.* **16**: 3057–3065.
- Guerrero, S.A., Lopez, J.A., Steinert, P., Montemartini, M., Kalisz, H.M., Colli, W., Singh, M., Alves, M.J., Flohé, L., 2000, His-tagged tryparedoxin peroxidase of *Trypanosoma cruzi* as a tool for drug screening. *Appl. Microbiol. Biotechnol.* **53**: 410–414.
- Haimeur, A., Brochu, C., Genest, P., Papadopoulou, B., Ouellette, M., 2000, Amplification of the ABC transporter gene PGPA and increased trypanothione levels in potassium antimonyl tartrate (SbIII) resistant *Leishmania tarentolae*. *Mol. Biochem. Parasitol.* **108**: 131–135.
- Henderson, G.B., Yamaguchi, M., Novoa, L., Fairlamb, A.H., Cerami, A., 1990, Biosynthesis of the trypanosomatid metabolite trypanothione: purification and characterization of trypanothione synthetase from *Crithidia fasciculata*. *Biochemistry* **29**: 3924–3929.
- Hillebrand, H., Schmidt, A., Krauth-Siegel, R.L., 2003, A second class of peroxidases linked to the trypanothione metabolism. *J. Biol. Chem.* **278**: 6809–6815.
- Hirotsu, S., Abe, Y., Okada, K., Nagahara, N., Hori, H., Nishino, T., Hakoshima, T., 1999, Crystal structure of a multifunctional 2-Cys peroxiredoxin heme-binding protein 23 kDa/proliferation-associated gene product. *Proc. Natl. Acad. Sci. USA* **96**: 12333–12338.
- Hofmann, B., Hecht, H.J., Flohé, L., 2002, Peroxiredoxins. *Biol. Chem.* **383**: 347–364.
- Irsch, T., Krauth-Siegel, R.L., 2004, Glyoxalase II of African trypanosomes is trypanothione-dependent. *J. Biol. Chem.* **279**: 22209–22217.
- Ivens, A.C., Peacock, C.S., Worthey, E.A., Murphy, L., Aggarwal, G., Berriman, M., et al., 2005, The genome of the kinetoplastid parasite, *Leishmania major*. *Science* **309**: 436–442.
- Jung, B.G., Lee, K.O., Lee, S.S., Chi, Y.H., Jang, H.H., Kang, S.S., Lee, K., Lim, D., Yoon, S.C., Yun, D.J., Inoue, Y., Cho, M.J., Lee, S.Y., 2002, A Chinese cabbage cDNA with high sequence identity to phospholipid hydroperoxide glutathione peroxidases encodes a novel isoform of thioredoxin-dependent peroxidase. *J. Biol. Chem.* **277**: 12572–12578.
- Koenig, K., Menge, U., Kiess, M., Wray, V., Flohé, L., 1997, Convenient isolation and kinetic mechanism of glutathionylspermidine synthetase from *Crithidia fasciculata*. *J. Biol. Chem.* **272**: 11908–11915.
- Krauth-Siegel, R.L., Lüdemann, H., 1996, Reduction of dehydroascorbate by trypanothione. *Mol. Biochem. Parasitol.* **80**: 203–208.
- Krauth-Siegel, R.L., Bauer, H., Schirmer, R.H., 2005, Dithiol proteins as guardians of the intracellular redox milieu in parasites: old and new drug targets in trypanosomes and malaria-causing plasmodia. *Angew. Chem. Int. Ed. Engl.* **44**: 690–715.
- Levick, M.P., Tetaud, E., Fairlamb, A.H., Blackwell, J.M., 1998, Identification and characterisation of a functional peroxidoxin from *Leishmania major*. *Mol. Biochem. Parasitol.* **96**: 125–137.
- Lin, Y.C., Hsu, J.Y., Chiang, S.C., Lee, S.T., 2005, Distinct overexpression of cytosolic and mitochondrial tryparedoxin peroxidases results in preferential detoxification of different oxidants in arsenite-resistant *Leishmania amazonensis* with and without DNA amplification. *Mol. Biochem. Parasitol.* **142**: 66–75.
- Lopez J.A., Carvalho T.U., de Souza W., Flohé L., Guerrero S.A., Montemartini M., Kalisz H.M., Nogoceke E., Singh M., Alves M.J., Colli W., 2000, Evidence for a trypanothione-dependent peroxidase system in *Trypanosoma cruzi*. *Free Radic. Biol. Med.* **28**: 767–772.
- Lüdemann, H., Dormeyer, M., Sticherling, C., Stallmann, D., Follmann, H., Krauth-Siegel, R.L., 1998, *Trypanosoma brucei* tryparedoxin, a thioredoxin-like protein in African trypanosomes. *FEBS Lett.* **431**: 381–385.

- Maiorino, M., Ursini, F., Bosello, V., Toppo, S., Tosatto, S.C., Mauri, P., Becker, K., Roveri, A., Bulato, C., Benazzi, L., De Palma, A., Flohé, L., 2007, The thioredoxin specificity of *Drosophila* GPx: A paradigm for a peroxiredoxin-like mechanism of many glutathione peroxidases. *J. Mol. Biol.* **365**: 1033–1046.
- Maya, J.D., Bollo, S., Nunez-Vergara, L.J., Squella, J.A., Repetto, Y., Morello, A., Perie, J., Chauviere, G., 2003, *Trypanosoma cruzi*: effect and mode of action of nitroimidazole and nitrofurant derivatives. *Biochem. Pharmacol.* **65**: 999–1006.
- Montemartini, M., Nogoceke, E., Singh, M., Steinert, P., Flohé, L., Kalisz, H.M., 1998, Sequence analysis of the tryparedoxin peroxidase gene from *Crithidia fasciculata* and its functional expression in *Escherichia coli*. *J. Biol. Chem.* **273**: 4864–4871.
- Montemartini, M., Kalisz, H.M., Hecht, H.J., Steinert, P., Flohé, L., 1999, Activation of active-site cysteine residues in the peroxiredoxin-type tryparedoxin peroxidase of *Crithidia fasciculata*. *Eur. J. Biochem.* **264**: 516–524.
- Montrichard, F., Le Guen, F., Laval-Martin, D.L., Davioud-Charvet, E., 1999, Evidence for the co-existence of glutathione reductase and trypanothione reductase in the non-trypanosomatid Euglenozoa: *Euglena gracilis* Z. *FEBS Lett.* **442**: 29–33.
- Motyka, S.A., Drew, M.E., Yildirim, G., Englund, P.T., 2006, Over-expression of a cytochrome B5 reductase-like protein causes kinetoplast DNA loss in *Trypanosoma brucei*. *J. Biol. Chem.* In press, PMID: 16690608.
- Moutiez, M., Meziane-Cherie, D., Aumercier, M., Sergheraert, C., Tartar, A., 1994, Compared reactivities of trypanothione and glutathione in conjugation reactions. *Chem. Pharm. Bull.* **42**: 2641–2644.
- Mukhopadhyay, R., Dey, S., Xu, N., Gage, D., Lightbody, J., Ouellette, M., Rosen, B.P., 1996, Trypanothione overproduction and resistance to antimonials and arsenicals in *Leishmania*. *Proc. Natl. Acad. Sci. USA* **93**: 10383–10387.
- Müller, S., Liebau, E., Walter, R.D., Krauth-Siegel, R.L., 2003, Thiol-based redox metabolism of protozoan parasites. *Trends Parasitol.* **19**: 320–328.
- Nogoceke, E., Gommel, D.U., Kiess, M., Kalisz, H.M., Flohé, L., 1997, A unique cascade of oxidoreductases catalyses trypanothione-mediated peroxide metabolism in *Crithidia fasciculata*. *Biol. Chem.* **378**: 827–836.
- Ondarza, R.N., Tamayo, E.H., Hurtado, G., Hernandez, E., Iturbe, A., 1997, Isolation and purification of glutathionyl-spermidine and trypanothione from *Entamoeba histolytica*. *Arch. Med. Res.* **28**: 73–75.
- Ondarza, R.N., Hurtado, G., Iturbe, A., Hernandez, E., Tamayo, E., Woolery, M., 2005, Identification of trypanothione from the human pathogen *Entamoeba histolytica* by mass spectrometry and chemical analysis. *Biotechnol. Appl. Biochem.* **42**: 175–181.
- Onn, I., Milman-Shtepel, N., Shlomai, J., 2004, Redox potential regulates binding of universal minicircle sequence binding protein at the kinetoplast DNA replication origin. *Eukaryot. Cell* **3**: 277–287.
- Oza, S.L., Ariyanayagam, M.R., Fairlamb, A.H., 2002a, Characterization of recombinant glutathionylspermidine synthetase/amidase from *Crithidia fasciculata*. *Biochem. J.* **364**: 679–686.
- Oza, S.L., Tetaud, E., Ariyanayagam, M.R., Warnon, S.S., and Fairlamb, A.H., 2002b, A single enzyme catalyses formation of trypanothione from glutathione and spermidine in *Trypanosoma cruzi*. *J. Biol. Chem.* **277**: 35853–35861.
- Oza, S.L., Ariyanayagam, M.R., Aitcheson, N., Fairlamb, A.H., 2003, Properties of trypanothione synthetase from *Trypanosoma brucei*. *Mol. Biochem. Parasitol.* **131**: 25–33.
- Oza, S.L., Shaw, M.P., Wyllie, S., Fairlamb, A.H., 2005, Trypanothione biosynthesis in *Leishmania major*. *Mol. Biochem. Parasitol.* **139**: 107–116.
- Padmanabhan, P.K., Mukherjee, A., Singh, S., Chattopadhyaya, S., Gowri, V.S., Myler, P.J., Srinivasan, N., Madhubala, R., 2005, Glyoxalase I from *Leishmania donovani*: a potential target for anti-parasite drug. *Biochem. Biophys. Res. Commun.* **337**: 1237–1248.
- Padmanabhan, P.K., Mukherjee, A., Madhubala, R., 2006, Characterization of the gene encoding glyoxalase II from *Leishmania donovani*: a potential target for anti-parasite drugs. *Biochem. J.* **393**: 227–234.
- Pineyro, M.D., Pizarro, J.C., Lema, F., Pritsch, O., Cayota, A., Bentley, G.A., Robello, C., 2005, Crystal structure of the tryparedoxin peroxidase from the human parasite *Trypanosoma cruzi*. *J. Struct. Biol.* **150**: 11–22.



- Reckenfelderbäumer, N., Krauth-Siegel, R.L., 2002, Catalytic properties, thiol pK value, and redox potential of *Trypanosoma brucei* tryparedoxin. *J. Biol. Chem.* **277**: 17548–17555.
- Repetto, Y., Opazo, E., Maya, J.D., Agosin, M., Morello, A., 1996, Glutathione and trypanothione in several strains of *Trypanosoma cruzi*: effect of drugs. *Comp. Biochem. Physiol. B, Biochem. Mol. Biol.* **115**: 281–285.
- Rhee, S.G., Chae, H.Z., Kim, K., 2005, Peroxiredoxins: a historical overview and speculative preview of novel mechanisms and emerging concepts in cell signaling. *Free Radic. Biol. Med.* **38**: 1543–1552.
- Schlecker, T., Schmidt, A., Dirdjaja, N., Voncken, F., Clayton, C., Krauth-Siegel, R.L., 2005, Substrate specificity, localization, and essential role of the glutathione peroxidase-type tryparedoxin peroxidases in *Trypanosoma brucei*. *J. Biol. Chem.* **280**: 14385–14394.
- Schmidt, H., Krauth-Siegel, R.L., 2003, Functional and physicochemical characterization of the thioredoxin system in *Trypanosoma brucei*. *J. Biol. Chem.* **278**: 46329–46336.
- Schröder, E., Littlechild, J.A., Lebedev, A.A., Errington, N., Vagin, A.A., Isupov, M.N., 2000, Crystal structure of decameric 2-Cys peroxiredoxin from human erythrocytes at 1.7 Å resolution. *Structure Fold Des.* **8**: 605–615.
- Shahi, S.K., Krauth-Siegel, R.L., Clayton, C.E., 2002, Overexpression of the putative thiol conjugate transporter TbMRPA causes melarsoprol resistance in *Trypanosoma brucei*. *Mol. Microbiol.* **43**: 1129–1138.
- Shim, H., Fairlamb, A.H., 1988, Levels of polyamines, glutathione and glutathione-spermidine conjugates during growth of the insect trypanosomatid *Crithidia fasciculata*. *J. Gen. Microbiol.* **134**: 807–817.
- Steenkamp, D.J., 2002, Thiol metabolism of the trypanosomatids as potential drug targets. *IUBMB Life* **53**: 243–248.
- Steinert, P., Plank-Schumacher, K., Montemartini, M., Hecht, H.J., Flohé, L., 2000, Permutation of the active site motif of tryparedoxin 2. *Biol. Chem.* **381**: 211–219.
- Sztajer, H., Gamain, B., Aumann, K. D., Slomianny, C., Becker, K., Brigelius-Flohé, R., Flohé, L., 2001, The putative glutathione peroxidase gene of *Plasmodium falciparum* codes for a thioredoxin peroxidase. *J. Biol. Chem.* **276**: 7397–7403.
- Tabor, H., Tabor, C.W., 1975, Isolation, characterization, and turnover of glutathionylspermidine from *Escherichia coli*. *J. Biol. Chem.* **250**: 2648–2654.
- Tanaka, T., Izawa, S., Inoue, Y., 2005, GPX2, encoding a phospholipid hydroperoxide glutathione peroxidase homologue, codes for an atypical 2-Cys peroxiredoxin in *Saccharomyces cerevisiae*. *J. Biol. Chem.* **280**: 42078–42087.
- Tetaud, E., Giroud, C., Prescott, A.R., Parkin, D.W., Baltz, D., Biteau, N., Baltz, T., Fairlamb, A.H., 2001, Molecular characterisation of mitochondrial and cytosolic trypanothione-dependent tryparedoxin peroxidases in *Trypanosoma brucei*. *Mol. Biochem. Parasitol.* **116**: 171–183.
- Thomson, L., Denicola, A., Radi, R., 2003, The trypanothione-thiol system in *Trypanosoma cruzi* as a key antioxidant mechanism against peroxynitrite-mediated cytotoxicity. *Arch. Biochem. Biophys.* **412**: 55–64.
- Trujillo, M., Budde, H., Pineyro, M.D., Stehr, M., Robello, C., Flohé, L., Radi, R., 2004, *Trypanosoma brucei* and *Trypanosoma cruzi* tryparedoxin peroxidases catalytically detoxify peroxynitrite via oxidation of fast reacting thiols. *J. Biol. Chem.* **279**: 34175–34182.
- Ullu, E., Tschudi, C., Chakraborty, T., 2004, RNA interference in protozoan parasites. *Cell. Microbiol.* **6**: 509–519.
- Vickers, T.J., Fairlamb, A.H., 2004, Trypanothione S-transferase activity in a trypanosomatid ribosomal elongation factor 1B. *J. Biol. Chem.* **279**: 27246–27256.
- Vickers, T.J., Wyllie, S.H., Fairlamb, A.H., 2004a, *Leishmania major* elongation factor 1B complex has trypanothione S-transferase and peroxidase activity. *J. Biol. Chem.* **279**: 49003–49009.
- Vickers, T.J., Greig, N., Fairlamb, A.H., 2004b, A trypanothione-dependent glyoxalase I with a prokaryotic ancestry in *Leishmania major*. *Proc. Natl. Acad. Sci. USA* **101**: 13186–13191.
- Vivancos, A.P., Castillo, E.A., Biteau, B., Nicot, C., Ayté, J., Toledano, M.B., Hidalgo, E., 2005, A cysteine-sulfinic acid in peroxiredoxin regulates H<sub>2</sub>O<sub>2</sub>-sensing by the antioxidant Pap1 pathway. *Proc. Natl. Acad. Sci. USA* **102**: 8875–8880.

- Walker, J., Acestor, N., Gongora, R., Quadroni, M., Segura, I., Fasel, N., Saravia, N.G., 2006, Comparative protein profiling identifies elongation factor-1beta and tryparedoxin peroxidase as factors associated with metastasis in *Leishmania guyanensis*. *Mol. Biochem. Parasitol.* **145**: 254–264.
- Wilkinson, S.R., Meyer, D.J., Kelly, J.M., 2000a, Biochemical characterization of a trypanosome enzyme with glutathione-dependent peroxidase activity. *Biochem. J.* **352**: 755–761.
- Wilkinson, S.R., Temperton, N.J., Mondragon, A., Kelly, J.M., 2000b, Distinct mitochondrial and cytosolic enzymes mediate trypanothione-dependent peroxide metabolism in *Trypanosoma cruzi*. *J. Biol. Chem.* **275**: 8220–8225.
- Wilkinson, S.R., Meyer, D.J., Taylor, M.C., Bromley, E.V., Miles, M.A., Kelly, J.M., 2002a, The *Trypanosoma cruzi* enzyme TcGPXI is a glycosomal peroxidase and can be linked to trypanothione reduction by glutathione or tryparedoxin. *J. Biol. Chem.* **277**: 17062–17071.
- Wilkinson, S.R., Obado, S.O., Mauricio, I.L., Kelly, J.M., 2002b, *Trypanosoma cruzi* expresses a plant-like ascorbate-dependent hemoperoxidase localized to the endoplasmic reticulum. *Proc. Natl. Acad. Sci. USA* **99**: 13453–13458.
- Wilkinson, S.R., Taylor, M.C., Touitha, S., Mauricio, I.L., Meyer, D.J., Kelly, J.M., 2002c, TcGPXII, a glutathione-dependent *Trypanosoma cruzi* peroxidase with substrate specificity restricted to fatty acid and phospholipid hydroperoxides, is localized to the endoplasmic reticulum. *Biochem. J.* **364**: 787–794.
- Wilkinson, S.R., Horn, D., Prathalingam, S.R., Kelly, J.M., 2003, RNA interference identifies two hydroperoxide metabolizing enzymes that are essential to the bloodstream form of the african trypanosome. *J. Biol. Chem.* **278**: 31640–31646.
- Wood, Z.A., Poole, L.B., Hantgan, R.R., Karplus, P.A., 2002, Dimers to doughnuts: redox-sensitive oligomerization of 2-cysteine peroxiredoxins. *Biochemistry* **41**: 5493–5504.
- Wood, Z.A., Poole, L.B., Karplus, P.A., 2003, Peroxiredoxin evolution and the regulation of hydrogen peroxide signaling. *Science* **300**: 650–653.
- Wyllie, S., Cunningham, M.L., Fairlamb, A.H., 2004, Dual action of antimonial drugs on thiol redox metabolism in the human pathogen *Leishmania donovani*. *J. Biol. Chem.* **279**: 39925–39932.

## CHAPTER 12

# FUNCTIONS OF TYPICAL 2-CYS PEROXIREDOXINS IN YEAST

BRIAN A. MORGAN AND ELIZABETH A. VEAL

*Institute of Cell and Molecular Biosciences, Faculty of Medical Sciences, Newcastle University,  
Newcastle upon Tyne, NE2 4HH, UK*

**Abstract:** Peroxiredoxins are ubiquitous proteins that are found from bacteria to humans. Until recently they were thought to solely act as antioxidants catalysing the reduction of peroxides through their associated thioredoxin peroxidase activity. However, recent work has begun to uncover hitherto unsuspected roles for one group of these proteins, the typical 2-Cys peroxiredoxins (2-Cys Prx). For example, typical 2-Cys Prxs have been found to have roles in the model organisms *Schizosaccharomyces pombe* and *Saccharomyces cerevisiae* in regulating signal transduction, in DNA damage responses and as molecular chaperones. There is increasing evidence that H<sub>2</sub>O<sub>2</sub> is utilised as a signalling molecule to regulate a range of important cellular processes. As abundant and ubiquitous peroxidase enzymes the peroxidase activity of typical 2-Cys Prxs is important in the regulation of these functions. Significantly, studies in yeast suggest that the regulation of the thioredoxin peroxidase and chaperone activities of these multi-function enzymes is an important aspect of H<sub>2</sub>O<sub>2</sub>-mediated signal transduction and consequently have provided important insight into the roles of these proteins in higher eukaryotes

**Keywords:** AP-1-like transcription factors, SAPK pathway, Peroxiredoxin, Sulphiredoxin, Protein oxidation, Signal transduction, Gene expression

### 1. INTRODUCTION

Oxidative stress occurs when the levels of ROS, such as H<sub>2</sub>O<sub>2</sub>, the hydroxyl radical and the superoxide anion, exceed the antioxidant capacity of the cell. The presence of these highly reactive molecules can result in damage to important cellular components and hence, not surprisingly, ROS have been linked with a wide range of human diseases and also with the normal ageing of cells. ROS arise as a normal by-product of respiration and also through the exposure of cells to environmental chemicals or ionising radiation. However, ROS are also utilised as signalling molecules by pathways involved in processes such as cell proliferation, differentiation, stress

responses, and apoptosis. An important component of the defence to oxidative stress is the sensing and signalling pathways by which cells adapt to the presence of ROS. The induction of such pathways leads to the up-regulated expression of genes encoding antioxidants and/or repair proteins. However, despite the central role played by antioxidants in the cellular response to oxidative stress there is still much to learn regarding the molecular mechanisms underlying the regulation of these responses and about the links between antioxidant function and ROS-regulated signal transduction pathways.

Studies in the model organisms, the budding yeast *Saccharomyces cerevisiae* and the fission yeast *Schizosaccharomyces pombe*, have provided valuable insights into responses to ROS such as H<sub>2</sub>O<sub>2</sub>. Furthermore, the evolutionary distance between these distantly related organisms has revealed both conserved and also organism-specific aspects of the molecular mechanisms by which the responses to H<sub>2</sub>O<sub>2</sub> are regulated in different organisms. An important aspect of the response of both these yeast to increased levels of ROS is the up-regulation of genes whose products provide repair and antioxidant functions. Antioxidants such as typical 2-Cys Prxs act as an important line of defence in response to ROS such as H<sub>2</sub>O<sub>2</sub>. *S. cerevisiae* contains two typical 2-Cys Prxs, Tsa1 and Tsa2, while *S. pombe* contains one such protein, Tpx1. Interestingly, recent studies have revealed that the peroxidatic cysteine of several eukaryotic typical 2-Cys Prxs is susceptible to inactivation by “overoxidation” to sulphinic acid (SO<sub>2</sub>H) or sulphonic acid (SO<sub>3</sub>H) at higher concentrations of peroxide (Wagner *et al.*, 2002; Wood *et al.*, 2003; Yang *et al.*, 2002). Moreover, enzyme activities have been identified in yeast and in mammals that are capable of reversing this inactivation (Biteau *et al.*, 2003; Budanov *et al.*, 2004; Chang *et al.*, 2004). For example, sulphiredoxin (Srx1) catalyses the reduction of the sulphinic acid derivative of the 2-Cys Prxs, Tsa1 in *S. cerevisiae* (Biteau *et al.*, 2003), and Tpx1 in *S. pombe* (Bozonet *et al.*, 2005; Vivancos *et al.*, 2005).

Recent work performed in several different yeasts has uncovered functions of eukaryotic typical 2-Cys Prxs in addition to their roles as antioxidants. In particular, these proteins have been found to have diverse functions, acting as regulators of signal transduction, molecular chaperones, and playing a key role in DNA damage responses. This work is summarised below.

## 2. TYPICAL 2-CYS PRXS AND SIGNAL TRANSDUCTION

Studies of eukaryotic typical 2-Cys Prxs have revealed that these proteins are more sensitive than their bacterial counterparts to overoxidation and thus inactivation of their peroxidase activity. These observations led to the “floodgate model” by Wood and colleagues (2003) where the inactivation of eukaryotic 2-Cys Prxs at relatively low levels of H<sub>2</sub>O<sub>2</sub> is important to allow H<sub>2</sub>O<sub>2</sub> to participate in signal transduction. In this model the peroxidase activity of typical 2-Cys Prxs acts as a barrier to H<sub>2</sub>O<sub>2</sub>-regulated signal transduction. Indeed, some studies in mammals have supported this role for 2-Cys Prxs; for example, in the regulation of the activation of the PDGF receptor (Choi *et al.*, 2005). However, studies in yeast have also uncovered

other roles for typical 2-Cys Prxs in signal transduction in response to  $H_2O_2$ . These studies are discussed below.

### 2.1. Regulation of $H_2O_2$ -induced Activation of the Yap1 Transcription Factor in *S. cerevisiae*

Work from several laboratories demonstrated that two related oxidative stress-activated AP-1-like transcription factors, Yap1 (*S. cerevisiae*) and Pap1 (*S. pombe*), cycle between the cytoplasm and the nucleus under normal conditions but that increased levels of ROS result in the nuclear accumulation of both proteins and the activation of target genes. As we will describe below, further studies have shown that different ROS activate Yap1 and Pap1 by distinct molecular mechanisms. Importantly, peroxiredoxins have been shown to be important for activation of Yap1 and Pap1 by  $H_2O_2$ .

Yap1 in *S. cerevisiae* contains a nuclear localisation sequence (NLS) and a nuclear export sequence (NES), which are located towards the N- and C-terminus, respectively. Although Yap1 is imported to the nucleus constitutively in unstressed conditions the NES of Yap1 interacts with the conserved nuclear export protein Crm1 preventing accumulation of the protein in the nucleus. However, in cells exposed to oxidative stress Yap1 becomes oxidised preventing interaction between Yap1 and Crm1 and thus blocking nuclear export (see Ikner and Shiozaki, 2005 and Toone *et al.*, 2001 for reviews). Delaunay and colleagues (2000) demonstrated that  $H_2O_2$  treatment, in contrast to other oxidising agents, results in the formation of an intramolecular disulphide bond between cysteine residues within cysteine-rich domains (CRD) located towards the N-terminus (n-CRD) and the C-terminus (c-CRD). This disulphide bond formation prevents interaction of the NES with Crm1 and causes Yap1 to accumulate in the nucleus.

To understand the mechanisms underlying the activation of gene expression in response to  $H_2O_2$  we performed a genetic screen in the W303 strain background of *S. cerevisiae* to identify mutations that prevented the  $H_2O_2$ -induced expression of the Yap1-regulated *TRX2* gene, encoding thioredoxin (Ross *et al.*, 2000). Excitingly, this study uncovered a mutant allele of the *TSA1* gene, encoding the typical 2-Cys Prx Tsa1. Although the mechanism of regulation by Tsa1 was not characterised, the observation that a loss of function mutation of Tsa1 prevents activation of  $H_2O_2$ -induced gene expression suggested that Tsa1 is required for the activation mechanism (Ross *et al.*, 2000). Using a different strain background Delaunay and colleagues demonstrated that Gpx3 (also known as Orp1), which although it does not share sequence homology with the peroxiredoxin protein family also has thioredoxin peroxidase activity, is required for  $H_2O_2$ -induced oxidation of Yap1 via a mechanism involving the transient formation of an intermolecular disulphide bond between Gpx3 and Yap1 (Delaunay *et al.*, 2002). Work from our laboratory identified another protein, Ybp1, that is essential for Gpx3-dependent oxidation and nuclear accumulation of Yap1 (Veal *et al.*, 2003). Interestingly, Ybp1 is located in the cytoplasm suggesting that this is the normal site of oxidation of Yap1 by

$H_2O_2$ . Intriguingly, in contrast to the strain background studied by Delaunay and colleagues, the W303 strain background contains a mutant allele of the *YBP1* gene, *ybp1-1*, that results in a substantial loss of Gpx3-dependent regulation of Yap1. Consistent with our previous work (Ross *et al.*, 2000), the 2-Cys Prx, Tsa1, has been found to regulate the  $H_2O_2$ -induced activation of Yap1 in these Ybp1-deficient, W303-related strains (Okazaki *et al.*, 2005).

One of the genes upregulated by Yap1 in response to oxidative stress is the *TRX2* gene, encoding thioredoxin. Thioredoxin activity has been shown to be important for the reduction of oxidised Yap1 and relocalisation of Yap1 to the cytoplasm. Hence, as thioredoxin also acts as an electron donor to both Gpx3 and Tsa1 this suggests that Yap1 is regulated via a negative feedback loop to repress Yap1 activity when  $H_2O_2$  levels are reduced and Gpx3 and Tsa1 become less active (Delaunay *et al.*, 2000; Delaunay *et al.*, 2002; Kuge *et al.*, 2001).

## 2.2. Regulation of $H_2O_2$ -induced Gene Expression in *S. pombe*

Previous studies have demonstrated that treatment of *S. pombe* cells with increasing concentrations of  $H_2O_2$  activates distinct patterns of gene expression. Furthermore, the Pap1 transcription factor, which is a homologue of Yap1 in *S. cerevisiae*, is more important for gene expression at low levels of  $H_2O_2$  and is inhibited by high levels of  $H_2O_2$  (Quinn *et al.*, 2002; Fig. 1). In contrast, the Atf1 transcription factor plays a more predominant role at higher levels of  $H_2O_2$  (Quinn *et al.*, 2002; Fig. 1). Based on the studies in *S. cerevisiae* (see above) it was possible that a 2-Cys Prx and/or

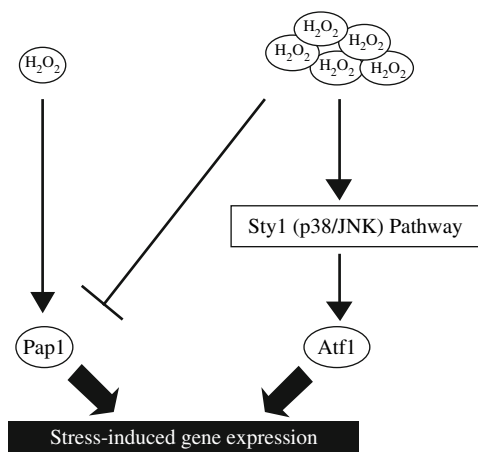

*Figure 1.* The response of *S. pombe* cells to increasing levels of  $H_2O_2$  is controlled by distinct mechanisms. The Pap1 transcription factor is more important for the activation of stress-induced gene expression at low levels of  $H_2O_2$  whilst the Atf1 transcription factor, regulated by the p38/JNK-related Sty1 pathway, is more important at higher levels of  $H_2O_2$ . In addition, the activity of Pap1 is inhibited at higher levels of  $H_2O_2$ .

Gpx3-like protein regulates H<sub>2</sub>O<sub>2</sub>-induced gene expression in *S. pombe*. Analysis of the genome database of *S. pombe* revealed a single gene, *tpx1*<sup>+</sup>, encoding a potential typical 2-Cys Prx, and a single gene, *gpx1*<sup>+</sup>, encoding a protein with significant homology to Gpx3. The studies described below demonstrated that Tpx1, and not Gpx1, is the major regulator of gene expression in response to H<sub>2</sub>O<sub>2</sub>. Furthermore, in contrast to *S. cerevisiae*, these studies revealed that Tpx1 regulates peroxide-induced gene expression by two independent mechanisms.

### 2.2.1. *Tpx1 regulates the Sty1 SAPK by a thioredoxin peroxidase-independent mechanism*

In eukaryotes, the p38/JNK stress-activated protein kinase (SAPK) pathways are activated in response to increased levels of ROS. Indeed, activation of the p38/JNK homologue, Sty1, is important for the regulation of ROS-induced gene expression through the activation of the Atf1 transcription factor in *S. pombe* (see Ikner and Shiozaki, 2005 and Toone and Jones, 1998 for reviews; Fig. 1). Previous work by us and others demonstrated that a two-component signal transduction pathway is important for regulating the Sty1 pathway in response to H<sub>2</sub>O<sub>2</sub> (Buck *et al.*, 2001; Nguyen *et al.*, 2000). However, Tpx1 was also found to be essential for the normal activation of Sty1 and Atf1-regulated gene expression in response to H<sub>2</sub>O<sub>2</sub> (Veal *et al.*, 2004). Furthermore, Tpx1 acts downstream from the two-component signalling pathway to regulate Sty1. Excitingly, this work suggested that Tpx1 enhances activation of Sty1 directly by a mechanism that involves formation of a H<sub>2</sub>O<sub>2</sub>-induced mixed disulphide complex between Tpx1 and Sty1. Mutational analysis revealed that the peroxidatic, but not the resolving, cysteine residue of Tpx1 is essential for the activation of Sty1 and, significantly, disulphide bond formation with Sty1. Importantly, this demonstrates that this Tpx1-dependent regulation of Sty1 was independent of the peroxidase activity of Tpx1. Sty1 contains a number of cysteine residues and several of these are highly conserved in other SAPKs. Significantly, one of these conserved cysteines in Sty1 (cysteine 35) was linked with Tpx1-dependent regulation of Sty1 (Veal *et al.*, 2004).

These studies revealed the first example of H<sub>2</sub>O<sub>2</sub>-induced oxidation of a SAPK and strongly suggest that typical 2-Cys Prxs influence H<sub>2</sub>O<sub>2</sub>-signalling through oxidation of key signal transduction proteins. Although it has yet to be established whether typical 2-Cys Prx are directly involved in activation of p38 in higher eukaryotes, a recent study has suggested that the 2-Cys Prx, Prx1, is required to stimulate activation of the p38 SAPK in macrophage-derived foam cells (Conway and Kinter, 2006).

### 2.2.2. *Tpx1 regulates the Pap1 transcription factor by a thioredoxin peroxidase-dependent mechanism*

Similar to Yap1 in *S. cerevisiae*, Pap1 has a major role in the regulation of H<sub>2</sub>O<sub>2</sub>-induced gene expression in *S. pombe*. Moreover, there are a number of similarities in the regulation of both Yap1 and Pap1. In particular, Pap1, like Yap1, cycles to and from the nucleus in unstressed cells in a Crm1-dependent

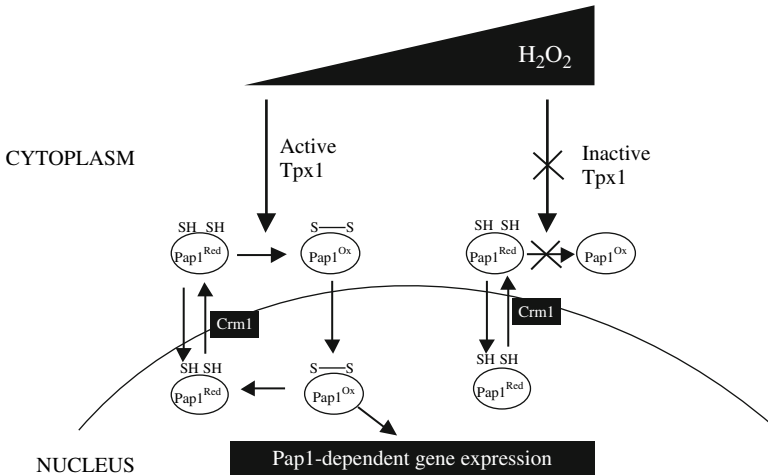

*Figure 2.* Model for the role of Tpx1 in the H<sub>2</sub>O<sub>2</sub>-induced activation of Pap1. In unstressed *S. pombe* cells Pap1 cycles to and from the nucleus in a Crm1-dependent manner. However, when cells are exposed to low levels of H<sub>2</sub>O<sub>2</sub> Pap1 becomes oxidised in a Tpx1-dependent manner which prevents the association of Pap1 with Crm1. This results in the nuclear accumulation of Pap1 and the activation of Pap1-dependent gene expression. However, at higher levels of H<sub>2</sub>O<sub>2</sub> the peroxidase activity of Tpx1 is inactivated by oxidation of Tpx1. This inactivation prevents the oxidation and nuclear accumulation of Pap1 and thus inhibits the activation of Pap1-dependent gene expression

manner (Toone *et al.*, 1998; see Ikner and Shiozaki, 2005 and Toone *et al.*, 2001 for reviews; Fig. 2). Furthermore, H<sub>2</sub>O<sub>2</sub> induces the formation of an intramolecular disulphide bond between cysteines located in the n-CRD and c-CRD regions of Pap1 which results in the nuclear accumulation and activation of the protein (Castillo *et al.*, 2002; Vivancos *et al.*, 2004). However, in contrast to Yap1, Gpx1, the only potential homologue of Gpx3 identified in *S. pombe*, was found not to be required for the H<sub>2</sub>O<sub>2</sub>-induced oxidation and nuclear accumulation of Pap1 (Bozonet *et al.*, 2005; Vivancos *et al.*, 2005). In addition, unlike Yap1, the oxidation of Pap1 is inhibited when cells are exposed to higher concentrations of H<sub>2</sub>O<sub>2</sub>, thus delaying the activation of Pap1-dependent gene expression (Vivancos *et al.*, 2004). These data suggested that the sensing mechanism(s) responsible for the activation of Pap1 is sensitive to the levels of H<sub>2</sub>O<sub>2</sub>. Although the Sty1 SAPK is important for the response of *S. pombe* to H<sub>2</sub>O<sub>2</sub>, significantly, the activation of Pap1 at low levels of H<sub>2</sub>O<sub>2</sub> is independent of activation of Sty1 suggesting the presence of an alternative regulatory mechanism(s) (Quinn *et al.*, 2002).

Given the roles of Tsa1 and Tpx1 in the regulation of H<sub>2</sub>O<sub>2</sub>-induced gene expression (see above) in *S. cerevisiae* (Yap1) and in *S. pombe* (Sty1/Atf1), respectively, it was possible that Tpx1 plays a role in the regulation of Pap1. Excitingly, we and others demonstrated that Tpx1 is essential for the H<sub>2</sub>O<sub>2</sub>-induced oxidation, nuclear accumulation and activation of Pap1 at low levels of H<sub>2</sub>O<sub>2</sub> and, moreover, that this regulation is independent of the activity of the Sty1 SAPK pathway



(Bozonet *et al.*, 2005; Vivancos *et al.*, 2005; Fig. 2). Importantly, in contrast to the Tpx1-dependent regulation of the Sty1 SAPK (see above), both the peroxidatic and resolving cysteines of Tpx1 are vital for this regulation of Pap1. Structural studies and protein sequence comparisons have suggested that typical 2-Cys Prxs containing two specific groups of amino acids within their predicted sequences are more sensitive to inactivation of their associated thioredoxin peroxidase activity by overoxidation at relatively low levels of peroxide (Wood *et al.*, 2003). Tpx1 contains both of these groups and indeed studies have suggested that Tpx1 is sensitive to overoxidation at relatively low levels of peroxide (Bozonet *et al.*, 2005; Koo *et al.*, 2002; Vivancos *et al.*, 2005; Wood *et al.*, 2003). The oxidation and nuclear accumulation of Pap1 is inhibited at high levels of  $H_2O_2$  and the studies of Tpx1 strongly suggest that this is due to the inactivation of the peroxidase activity of Tpx1 via oxidation (Fig. 2). Indeed, significantly, the Srx1 sulphiredoxin that reverses overoxidation of Tpx1 in *S. pombe* was found to be essential for the oxidation and nuclear accumulation of Pap1 in a Tpx1-dependent manner at high but not low levels of  $H_2O_2$  (Bozonet *et al.*, 2005; Vivancos *et al.*, 2005; Fig. 3). The expression of *srx1*<sup>+</sup> is strongly induced by  $H_2O_2$  and hence the activation and timing of Pap1-regulated gene expression is dependent on both the level of  $H_2O_2$  present and on the levels of activity of Srx1 (Bozonet *et al.*, 2005; Vivancos *et al.*, 2005; Fig. 3). Collectively, these results suggest that the sensitivity of the peroxidase activity of Tpx1 to increasing concentrations of  $H_2O_2$  acts as a redox sensor to regulate Pap1-dependent gene expression. Currently it is not clear whether Tpx1 acts like Gpx3 in *S. cerevisiae* by forming an intermolecular disulphide with

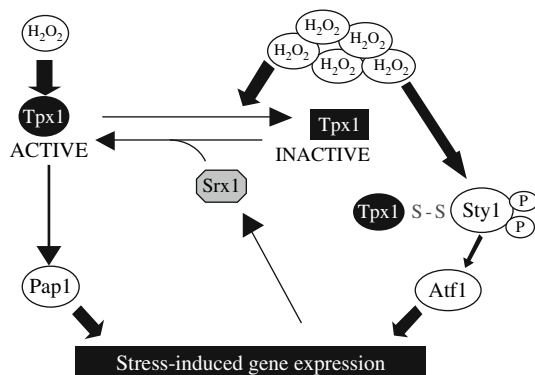

**Figure 3. Tpx1 and Srx1 are important for the regulation of cellular responses to  $H_2O_2$ .** The peroxidase activity of Tpx1 is required for the activation of Pap1 in response to low levels of  $H_2O_2$ . However, at higher levels of  $H_2O_2$  the peroxidase activity of Tpx1 is inhibited by oxidation preventing the activation of Pap1. Tpx1 is also required for the activation of Sty1 by  $H_2O_2$  but via a peroxidase-independent mechanism. At high levels of  $H_2O_2$  the expression of the gene encoding Srx1 (*srx1*<sup>+</sup>) is induced which then results in the reversal of oxidation of Tpx1 and allows the subsequent activation of Pap1. Thus, the timing of induction of *srx1*<sup>+</sup> expression acts as a molecular switch to determine the precise patterns of  $H_2O_2$ -induced gene expression at high levels of  $H_2O_2$

Pap1 or whether it acts in a more indirect manner. However, Pap1 and Tpx1 co-immunoprecipitate from yeast extracts, suggesting that the proteins are contained in the same complex and, significantly, this complex formation is inhibited by high levels of  $H_2O_2$  (Bozonet, Veal and Morgan, unpublished).

In summary, studies have revealed that the typical 2-Cys Prx Tpx1 plays a key role in the control of the response of *S. pombe* cells to  $H_2O_2$  by regulating the two main branches of this response - the Sty1 SAPK and Pap1 branches - by two different molecular mechanisms. In the Pap1 branch the peroxidase activity/oxidation state of Tpx1 determines the timing of the  $H_2O_2$ -induced oxidation, nuclear accumulation and activation of Pap1 (Fig. 3). Hence at high levels of  $H_2O_2$  the peroxidase activity of Tpx1 is inactivated thus delaying Pap1 oxidation and nuclear accumulation until the oxidation of Tpx1 is reversed by Srx1 (Fig. 3). In the Sty1 SAPK branch, Tpx1 is required for the activation of Sty1 by  $H_2O_2$  via a peroxidase-independent mechanism (Fig. 3). Hence, by regulating different pathways by alternative mechanisms, Tpx1 appears to act as a molecular switch to activate the appropriate transcriptional response depending on the level of  $H_2O_2$  (Fig. 3). Based on these studies of Tpx1 in *S. pombe*, and given the sensitivity of eukaryotic 2-Cys Prx such as Tpx1 to oxidation and inactivation by relatively low levels of  $H_2O_2$ , it is tempting to speculate that the increased sensitivity of 2-Cys Prx such as Tpx1 may have evolved to allow distinct cellular responses to different levels of  $H_2O_2$ .

### 3. TYPICAL 2-CYS PRX ACT AS MOLECULAR CHAPERONES IN *S. CEREVISIAE*

The studies described above revealed that typical 2-Cys Prxs act as regulators of signal transduction in addition to their roles as antioxidants. However, recent studies of typical 2-Cys Prxs in both prokaryotes and eukaryotes have found that these proteins can also act as molecular chaperones. Previous studies demonstrated that typical 2-Cys Prxs can exist in a number of structural forms (Wood *et al.*, 2002). In *S. cerevisiae* the appearance of high molecular weight forms of Tsa1 is stimulated by conditions such as oxidative stress and heat shock (Jang *et al.*, 2004). Excitingly, these high molecular weight forms of Tsa1 were found to display molecular chaperone activity (Jang *et al.*, 2004). It appears that while the thioredoxin system is required for the  $H_2O_2$ -induced formation of these high molecular weight complexes the Srx1 sulphiredoxin stimulates the dissociation of the complexes. Recent work has revealed that one important role of this molecular chaperone activity of Tsa1 is to protect ribosomal proteins from aggregation in response to reductive stress in *S. cerevisiae* (Rand and Grant, 2006). Although the reductive stress in the study of Rand and Grant (2006) did not appear to be caused by increased ROS production, the peroxidatic and resolving cysteines of Tsa1 were required for resistance, suggesting a role for the thioredoxin peroxidase activity in molecular chaperone function under these conditions. These studies suggest that typical 2-Cys Prxs act as thioredoxin peroxidases in their low molecular weight

forms but can also act as molecular chaperones when cells are exposed to higher levels of H<sub>2</sub>O<sub>2</sub>, heat stress or reductive stress.

Given the link between the inactivation of typical 2-Cys Prxs and signal transduction it is interesting to speculate that some of the proposed roles of typical 2-Cys Prxs in signal transduction may be dependent, at least in part, on molecular chaperone activity. Importantly, these results clearly demonstrate that the precise functions of typical 2-Cys Prxs are determined by the distinct conditions to which the protein is exposed in the particular cell locality.

#### 4. TYPICAL 2-CYS PRX AND THE RESPONSE TO DNA DAMAGE

The 2-Cys Prx Tsa1 plays a central role in the resistance of *S. cerevisiae* cells to oxidative stress such as that caused by increased levels of H<sub>2</sub>O<sub>2</sub>. Consistent with this role work from several laboratories has shown that Tsa1 is intimately involved with the responses of cells to DNA damage. For example, large scale screens identified Tsa1 as a suppressor of point mutations and gross chromosomal rearrangements (Huang *et al.*, 2003; Smith *et al.*, 2004). Although the precise functions of Tsa1 in this suppression were not elucidated, studies by Wong and colleagues suggested that this suppression was linked to the peroxidase function of Tsa1 (Wong *et al.*, 2004). Recently, studies of Tsa1 demonstrated that the protein acts together with key repair pathways and DNA damage and replication cell cycle checkpoints in a biological network that prevents ROS-induced DNA damage (Huang and Kolodner, 2005). The importance of these observations in yeast is emphasised by studies of mice lacking a typical 2-Cys Prx which were found to display increased rates of cancer development (Neumann *et al.*, 2003). Collectively, these studies suggest that typical 2-Cys Prxs likely play key roles as DNA damage suppressors in eukaryotes and hence act as tumour suppressors in metazoa.

#### 5. FUNCTIONS OF TYPICAL 2-CYS PRX IN OTHER YEASTS

Some studies of typical 2-Cys Prxs have also been performed in other yeasts.

##### 5.1. Typical 2-Cys Prx in *Candida albicans*

*Candida albicans* is an important fungal pathogen of humans that causes superficial infections (thrush) in many individuals and also life-threatening systemic infections in immunocompromised patients. Importantly, stress responses are intimately linked with the pathogenicity of *C. albicans*. For example, *C. albicans* can evade oxidative killing by macrophages, and inactivating key stress-protective enzymes or stress-signalling proteins attenuates virulence. However, despite the tight association between stress responses and virulence, surprisingly little is known about the molecular mechanisms underlying the regulation of such responses. *C. albicans* contains four genes encoding an identical typical 2-Cys Prx, Tsa1, which is closely related to Tsa1 of *S. cerevisiae*. Importantly, the expression of *TSA1* in *C. albicans*

is induced in response to oxidative stress (Enjalbert *et al.*, 2003; 2006) and this is dependent on the function of Cap1, the *C. albicans* orthologue of Yap1 and Pap1 (Urban *et al.*, 2005). Hence, not surprisingly, Tsa1 was found to be required for the oxidative stress response in *C. albicans* (Shin *et al.*, 2005; Urban *et al.*, 2005). However, in contrast to *S. cerevisiae* and *S. pombe*, Tsa1 appears to play a different role in the regulation of oxidative stress-induced gene expression in *C. albicans* (Urban *et al.*, 2005). For example, unlike the Tsa1-dependent regulation of H<sub>2</sub>O<sub>2</sub>-induced expression of the *TRR1* gene, encoding thioredoxin reductase, in the W303 strain background of *S. cerevisiae* (Ross *et al.*, 2000), and the Tpx1-dependent regulation of H<sub>2</sub>O<sub>2</sub>-induced gene expression in *S. pombe* (Bozonet *et al.*, 2005; Vivancos *et al.*, 2005), Tsa1 is not required to activate the expression of the *TRR1* gene in *C. albicans* cells exposed to H<sub>2</sub>O<sub>2</sub> (Urban *et al.*, 2005). However, the expression of some other genes was down-regulated in  $\Delta$ *tsa1* cells treated with H<sub>2</sub>O<sub>2</sub> (Urban *et al.*, 2005). Thus, the precise role(s) of Tsa1 in oxidative stress-induced gene expression in *C. albicans* remains to be determined.

Tsa1 has also been linked with morphological changes of *C. albicans* cells. *C. albicans* cells can be found in one of several different morphologies and, importantly, morphological transitions have been linked to the pathogenicity of the organism. Interestingly, 2D protein gel analysis of the yeast-to-hyphal transition suggested that both the levels of Tsa1 protein and its posttranslational modification by oxidation, increases following a shift to the hyphal form (Choi *et al.*, 2003). Furthermore, Tsa1 was found to have roles in the yeast-to-hyphal transition (Shin *et al.*, 2005; Urban *et al.*, 2005). Several studies have also shown that the cellular localisation of Tsa1 changes under hyphae-inducing conditions, suggesting specific roles in the process (Shin *et al.*, 2005; Urban *et al.*, 2003; 2005). However, despite the links between Tsa1 and oxidative stress resistance and also morphogenesis, perhaps surprisingly, the virulence of *C. albicans* appears to be unaffected by loss of Tsa1 in the models tested to date (Urban *et al.*, 2005).

## 5.2. Typical 2-Cys Prx in *Cryptococcus neoformans*

*Cryptococcus neoformans* is a fungal pathogen particularly relevant for immunocompromised patients. Importantly, consistent with the studies outlined above, a typical 2-Cys Prx, Tsa1, which is closely related to Tsa1 in *S. cerevisiae*, was found to be involved in the response of *C. neoformans* cells to oxidative stress (Missall *et al.*, 2004). Furthermore, *C. neoformans* cells lacking Tsa1 were found to be less virulent than wild type cells in mouse models (Missall *et al.*, 2004). Significantly, this effect on virulence contrasts with studies in *C. albicans* (see above). Intriguingly, initial studies suggest that Tsa1 is linked to the regulation of oxidative stress-induced gene expression in *C. neoformans*. In particular, analysis of  $\Delta$ *tsa1* mutant cells implicated Tsa1 in the regulation of the expression of the *LAC2* gene, encoding laccase, in response to oxidative stress (nitrosative stress and H<sub>2</sub>O<sub>2</sub> stress) (Missall *et al.*, 2005). Although the mechanism(s) of regulation has not been elucidated the expression of the *TSA1* gene is induced in response to

nitric oxide stress and the Tsa1 protein appears to undergo at least two different posttranslational modifications (Missall *et al.*, 2006).

These studies demonstrate that typical 2-Cys Prxs play central roles in the response of different yeast cells to ROS. Moreover, taken together with the studies in *S. cerevisiae* and *S. pombe*, typical 2-Cys Prxs clearly influence a diverse range of cellular processes in yeast.

## 6. CONCLUSIONS AND PERSPECTIVES

Typical 2-Cys Prxs were originally proposed to act as antioxidants in the response of cells to oxidative stress. However, studies in models such as yeast have provided important insights into the roles and functions of typical 2-Cys Prxs in eukaryotes. In particular, 2-Cys Prxs have been revealed as versatile and multifunctional proteins, playing central roles in cells as antioxidants, molecular chaperones and regulators of signal transduction. Furthermore, the functions of these proteins are modulated in yeast by a panoply of mechanisms, including regulation of gene expression and/or cellular localisation and posttranslational modifications. It is clear from studies in other eukaryotes that many aspects of the functions and regulation of these proteins are highly conserved and hence studies in organisms such as yeast will likely provide further insight into the roles of these proteins in plants and metazoa.

## ACKNOWLEDGEMENTS

We thank our colleagues at Newcastle for advice and discussions. The work was funded by Cancer Research UK and the Medical Research Council.

## REFERENCES

- Biteau, B., Labarre, J., Toledano, M.B., 2003, ATP-dependent reduction of cysteine-sulphinic acid by *S. cerevisiae* sulphiredoxin. *Nature* **425**: 980–984.
- Bozonet, S.M., Findlay, V.J., Day, A.M., Cameron, J., Veal, E.A., Morgan, B.A., 2005, Oxidation of a eukaryotic 2-Cys peroxiredoxin is a molecular switch controlling the transcriptional response to increasing levels of hydrogen peroxide. *J. Biol. Chem.* **280**: 23319–23327.
- Buck, V., Quinn, J., Soto Pino, T., Martin, H., Saldanha, J., Makino, K., Morgan, B.A., Millar, J.B., 2001, Peroxide sensors for the fission yeast stress-activated mitogen-activated protein kinase pathway. *Mol. Biol. Cell* **12**: 407–419.
- Budanov, A.V., Sablina, A.A., Feinstein, E., Koonin, E.V., Chumakov, P.M., 2004, Regeneration of peroxiredoxins by p53-regulated sestrins, homologs of bacterial AhpD. *Science* **304**: 596–600.
- Castillo, E.A., Ayte, J., Chiva, C., Moldon, A., Carrascal, M., Abian, J., Jones, N., Hidalgo, E., 2002, Diethylmaleate activates the transcription factor Pap1 by covalent modification of critical cysteine residues. *Mol. Microbiol.* **45**: 243–254.
- Chang, T.S., Jeong, W., Woo, H.A., Lee, S.M., Park, S., Rhee, S.G., 2004, Characterization of mammalian sulfiredoxin and its reactivation of hyperoxidized peroxiredoxin through reduction of cysteine sulfinic acid in the active site to cysteine. *J. Biol. Chem.* **279**: 50994–51001.
- Choi, M.H., Lee, I.K., Kim, G.W., Kim, B.U., Han, Y.H., Yu, D.Y., Park, H.S., Kim, K.Y., Lee, J.S., Choi, C., Bae, Y.S., Lee, B.I., Rhee, S.G., Kang, S.W., 2005, Regulation of PDGF signalling and vascular remodelling by peroxiredoxin II. *Nature* **435**: 347–353.

- Choi, W., Yoo, Y.J., Kim, M., Shin, D., Jeon, H.B., Choi, W., 2003, Identification of proteins highly expressed in the hyphae of *Candida albicans* by two-dimensional electrophoresis. *Yeast* **20**: 1053–1060.
- Conway, J.P., Kinter, M., 2006, Dual role of peroxiredoxin I in macrophage-derived foam cells. *J. Biol. Chem.* **281**: 27991–28001.
- Delaunay, A., Isnard, A.D., Toledano, M.B., 2000, H<sub>2</sub>O<sub>2</sub> sensing through oxidation of the Yap1 transcription factor. *EMBO J.* **19**: 5157–5166.
- Delaunay, A., Pflieger, D., Barrault, M.B., Vinh, J., Toledano, M.B., 2002, A thiol peroxidase is an H<sub>2</sub>O<sub>2</sub> receptor and redox-transducer in gene activation. *Cell* **111**: 471–481.
- Enjalbert, B., Nantel, A., Whiteway, M., 2003, Stress-induced gene expression in *Candida albicans*: absence of a general stress response. *Mol. Biol. Cell* **14**: 1460–1467.
- Enjalbert, B., Smith, D.A., Cornell, M.J., Alam, I., Nicholls, S., Brown, A.J.P., Quinn, J., 2006, Role of the Hog1 stress-activated protein kinase in the global transcriptional response to stress in the fungal pathogen *Candida albicans*. *Mol. Biol. Cell* **17**: 1018–1032.
- Huang, M.E., Kolodner, R.D., 2005, A biological network in *Saccharomyces cerevisiae* prevents the deleterious effects of endogenous oxidative DNA damage. *Mol. Cell* **17**: 709–720.
- Huang, M.E., Rio, A.G., Nicolas, A., Kolodner, R.D., 2003, A genomewide screen in *Saccharomyces cerevisiae* for genes that suppress the accumulation of mutations. *Proc. Natl. Acad. Sci. USA* **100**: 11529–11534.
- Ikner, A., Shiozaki, K., 2005, Yeast signaling pathways in the oxidative stress response. *Mutat. Res.* **569**: 13–27.
- Jang, H.H., Lee, K.O., Chi, Y.H., Jung, B.G., Park, S.K., Park, J.H., Lee, J.R., Lee, S.S., Moon, J.C., Yun, J.W., Choi, Y.O., Kim, W.Y., Kang, J.S., Cheong, G.W., Yun, D.J., Rhee, S.G., Cho, M.J., Lee, S.Y., 2004, Two enzymes in one; two yeast peroxiredoxins display oxidative stress-dependent switching from a peroxidase to a molecular chaperone function. *Cell* **117**: 625–635.
- Koo, K.H., Lee, S., Jeong, S.Y., Kim, E.T., Kim, H.J., Kim, K., Song, K., Chae, H.Z., 2002, Regulation of thioredoxin peroxidase activity by C-terminal truncation. *Arch. Biochem. Biophys.* **397**: 312–318.
- Kuge, S., Arita, M., Murayama, A., Maeta, K., Izawa, S., Inoue, Y., Nomoto, A., 2001, Regulation of the yeast Yap1p nuclear export signal is mediated by redox signal-induced reversible disulfide bond formation. *Mol. Cell. Biol.* **21**: 6139–6150.
- Missall, T.A., Moran, J.M., Corbett, J.A., Lodge, J.K., 2005, Distinct stress responses of two functional laccases in *Cryptococcus neoformans* are revealed in the absence of the thiol-specific antioxidant Tsa1. *Eukaryot. Cell* **4**: 202–208.
- Missall, T.A., Pusateri, M.E., Donlin, M.J., Chambers, K.T., Corbett, J.A., Lodge, J.K., 2006, Posttranslational, translational, and transcriptional responses to nitric oxide stress in *Cryptococcus neoformans*: implications for virulence. *Eukaryot. Cell* **5**: 518–529.
- Missall, T.A., Pusateri, M.E., Lodge, J.K., 2004, Thiol peroxidase is critical for virulence and resistance to nitric oxide and peroxide in the fungal pathogen, *Cryptococcus neoformans*. *Mol. Microbiol.* **51**: 1447–1458.
- Neumann, C.A., Krause, D.S., Carman, C.V., Das, S., Dubey, D.P., Abraham, J.L., Bronson, R.T., Fujiwara, Y., Orkin, S.H., Van Etten, R.A., 2003, Essential role for the peroxiredoxin Prdx1 in erythrocyte antioxidant defence and tumour suppression. *Nature* **424**: 561–565.
- Nguyen, A.N., Lee, A., Place, W., Shiozaki, K., 2000, Multistep phosphorelay proteins transmit oxidative stress signals to the fission yeast stress-activated protein kinase. *Mol. Biol. Cell* **11**: 1169–1181.
- Okazaki, S., Naganuma, A., Kuge, S., 2005, Peroxiredoxin-mediated redox regulation of the nuclear localization of Yap1, a transcription factor in budding yeast. *Antioxid. Redox Signal.* **7**: 327–334.
- Quinn, J., Findlay, V.J., Dawson, K., Jones, N., Morgan, B.A., Toone, W.M., 2002, Distinct regulatory proteins control the adaptive and acute responses to H<sub>2</sub>O<sub>2</sub> in *Schizosaccharomyces pombe*. *Mol. Biol. Cell* **13**: 805–816.
- Rand, J.D., Grant, C.M., 2006, The thioredoxin system protects ribosomes against stress-induced aggregation. *Mol. Biol. Cell* **17**: 387–401.
- Ross, S.J., Findlay, V.J., Malakasi, P., Morgan, B.A., 2000, Thioredoxin peroxidase is required for the transcriptional response to oxidative stress in budding yeast. *Mol. Biol. Cell* **11**: 2631–2642.

- Shin, D.H., Jung, S., Park, S.J., Kim, Y.J., Ahn, J.M., Kim, W., Choi, W., 2005, Characterization of thiol-specific antioxidant 1 (TSA1) of *Candida albicans*. *Yeast* **22**: 907–918.
- Smith, S., Hwang, J.Y., Banerjee, S., Majeed, A., Gupta, A., and Myung, K., 2004, Mutator genes for suppression of gross chromosomal rearrangements identified by a genome-wide screening in *Saccharomyces cerevisiae*. *Proc. Natl. Acad. Sci. USA* **101**: 9039–9044.
- Toone, W.M., Jones, N., 1998, Stress-activated signalling pathways in yeast. *Genes Cells* **3**: 485–498.
- Toone, W.M., Kuge, S., Samuels, M., Morgan, B.A., Toda, T., Jones, N., 1998, Regulation of the fission yeast transcription factor Pap1 by oxidative stress: requirement for the nuclear export factor Crm1 (Exportin) and the stress-activated MAP kinase Sty1/Spc1. *Genes Dev.* **12**: 1453–1463.
- Toone, W.M., Morgan, B.A., Jones, N., 2001, Redox control of AP-1-like factors in yeast and beyond. *Oncogene* **20**: 2336–2346.
- Urban, C., Sohn, K., Lottspeich, F., Brunner, H., Rupp, S., 2003, Identification of cell surface determinants in *Candida albicans* reveals Tsa1p, a protein differentially localized in the cell. *FEBS Lett.* **544**: 228–235.
- Urban, C., Xiong, X., Sohn, K., Schroppel, K., Brunner, H., Rupp, S., 2005, The moonlighting protein Tsa1p is implicated in oxidative stress response and in cell wall biogenesis in *Candida albicans*. *Mol. Microbiol.* **57**: 1318–1341.
- Veal, E.A., Findlay, V.J., Day, A.M., Bozonet, S.M., Evans, J.M., Quinn, J., Morgan, B.A., 2004, A 2-Cys peroxiredoxin regulates peroxide-induced oxidation and activation of a stress-activated MAP kinase. *Mol. Cell* **15**: 129–139.
- Veal, E.A., Ross, S.J., Malakasi, P., Peacock, E., Morgan, B.A., 2003, Ybp1 is required for the hydrogen peroxide-induced oxidation of the Yap1 transcription factor. *J. Biol. Chem.* **278**: 30896–30904.
- Vivancos, A.P., Castillo, E.A., Biteau, B., Nicot, C., Ayte, J., Toledano, M.B., Hidalgo, E., 2005, A cysteine-sulfinic acid in peroxiredoxin regulates H<sub>2</sub>O<sub>2</sub>-sensing by the antioxidant Pap1 pathway. *Proc. Natl. Acad. Sci. USA* **102**: 8875–8880.
- Vivancos, A.P., Castillo, E.A., Jones, N., Ayte, J., Hidalgo, E., 2004, Activation of the redox sensor Pap1 by hydrogen peroxide requires modulation of the intracellular oxidant concentration. *Mol. Microbiol.* **52**: 1427–1435.
- Wagner, E., Luche, S., Penna, L., Chevallet, M., Van Dorsselaer, A., Leize-Wagner, E., Rabilloud, T., 2002, A method for detection of overoxidation of cysteines: peroxiredoxins are oxidized in vivo at the active-site cysteine during oxidative stress. *Biochem. J.* **366**: 777–785.
- Wong, C.M., Siu, K.L., Jin, D.Y., 2004, Peroxiredoxin-null yeast cells are hypersensitive to oxidative stress and are genomically unstable. *J. Biol. Chem.* **279**: 23207–23213.
- Wood, Z.A., Poole, L.B., Hantgan, R.R., Karplus, P.A., 2002, Dimers to doughnuts: redox-sensitive oligomerization of 2-cysteine peroxiredoxins. *Biochemistry* **41**: 5493–5504.
- Wood, Z.A., Poole, L.B., Karplus, P.A., 2003, Peroxiredoxin evolution and the regulation of hydrogen peroxide signaling. *Science* **300**: 650–653.
- Yang, K.S., Kang, S.W., Woo, H.A., Hwang, S.C., Chae, H.Z., Kim, K., Rhee, S.G., 2002, Inactivation of human peroxiredoxin I during catalysis as the result of the oxidation of the catalytic site cysteine to cysteine-sulfinic acid. *J. Biol. Chem.* **277**: 38029–38036.

## CHAPTER 13

# THE DUAL FUNCTION OF PLANT PEROXIREDOXINS IN ANTIOXIDANT DEFENCE AND REDOX SIGNALING

KARL-JOSEF DIETZ

*Biochemistry and Physiology of Plants, Faculty of Biology W5-134, University of Bielefeld, 33501 Bielefeld, Germany*

**Abstract:** With 8 to 10 members, the peroxiredoxin gene family of each higher plant with known genome sequence is larger than in other eukaryotes. Likewise, the complexity of reductive regenerants is very high, e.g. the chloroplast 2-Cys Prx is reduced by various thioredoxins, cyclophilin Cyp20-3, the drought induced CDSP32 and the NADPH-dependent reductant NTRC. In the light of the apparent versatility of the peroxiredoxin system in plants, its specific and important functions in antioxidant defence, photosynthesis and stress adaptation, the review attempts a survey of present day knowledge on plant peroxiredoxins, their biochemical features and transcript regulation, as well as their function in photosynthesis, development, stress response and pathogenesis. The emerging evidence for plant Prx function in cell signaling is summarized

**Keywords:** *Arabidopsis thaliana*, Peroxiredoxin, Chloroplast, Mitochondrion, Signaling, thiol proteome, Transcript regulation

**Abbreviations:** ABA: abscisic acid; ABI: ABA-insensitive; ABRE: ABA response element; CAT: catalase; APX: ascorbate peroxidase; DHA: dehydroascorbate; DHAR: DHA reductase; Grx: glutaredoxin; GR: glutathione reductase; GSH: glutathione; GSSG: oxidized glutathione; KatG: catalase/oxidase; MDA: mono-dehydroascorbate; Prx: peroxiredoxin; SOD: superoxide dismutase; Trx: thioredoxin

## 1. INTRODUCTION

Oxidative strain to cells is intricately linked to modification of proteins with subsequent dysregulation of metabolism. Particularly sulphur-containing amino acids are prone to oxidation if cell metabolism generates strongly oxidizing agents such as reactive oxygen species at rates higher than they can be detoxified by the antioxidant defence system. By consecutive steps of oxidation the thiol group converts to disulfide, or via sulfenic to sulfinic acid and sulfonic acid derivatives of the cysteinyl residue. Furthermore, nitrosylation of thiols is an



additional modification that occurs in cells. Thiol nitrosylation has recently received increasing attention also in plants and is being suggested to be involved in cell signaling leading to adaptation and cell death (Lindermayr *et al.* 2005). All these modifications have the potential to alter protein functions. Particularly, intra- and intermolecular disulfide formation is an often employed posttranslational modification that reversibly switches enzymes between an active and an inactive state (Schürmann and Jacquot 2000). Various proteome-wide biochemical and bioinformatic screenings for thiol/disulfide transition proteins and thioredoxin or glutaredoxin targets have identified more than 500 proteins that undergo thiol/disulfide transitions in plants, including peroxiredoxins, in fact in most screens (e.g. Balmer *et al.*, 2003; Rouhier *et al.*, 2005; Ströher and Dietz, 2006; unpublished results). This type of biochemical and genome-based approach is unlikely to have even approached saturation in the identification of thiol-disulfide targets. New and alternative methods of proteomics and bioinformatics will have to be deployed and developed to reach this goal (Ströher and Dietz, 2006). Peroxiredoxins with their highly reactive catalytic cysteine residue are part of the thiol proteome (Motohoashi *et al.*, 2001; Rouhier *et al.*, 2005b) and function as thiol sinks preferentially decomposing reactive oxygen and nitrogen species.

The large number of potential targets for protein thiol oxidation implies that maintenance of a balanced redox environment and a proper thiol-disulfide homeostasis are essential features of each cell. Both parameters need to be tightly controlled within narrow limits of the redox state (Dietz, 2003a). In yeast, the redox state of the glutathione redox couple  $[2 \text{ GSH}]/[\text{GSSG}]$  is correlated with developmental state (Schafer and Buettner, 2001). A redox potential of about  $-170 \text{ mV}$  indicated apoptosis,  $-200 \text{ mV}$  differentiation and  $-240 \text{ mV}$  cell division. Such analyses are lacking for animal and plant cells or have not given unequivocal results. But the principle relationship is likely to exist in other eukaryotic cells too.

In addition to reactive intermediates generated in heterotrophic metabolism of all organisms, oxygenic photosynthesis produces redox intermediates with exceedingly negative redox potential. For example ferredoxin, a Fe-based redox protein, is reduced at the acceptor site of photosystem I and has an  $E_m^\circ$  of  $-450 \text{ mV}$ . Ferredoxin is a central distributor for high energy electrons that are donated to various cosubstrates via appropriate enzymes and electron carriers, particularly  $\text{NADP}^+$ , thioredoxin, nitrite and oxygen (Backhausen *et al.*, 2000; Holtgreffe *et al.*, 2003). Photosynthesis generates reactive oxygen species such as singlet oxygen in photosystem II, superoxide anion radical in the intersystem electron transport chain and at photosystem I, and hydrogen peroxide by superoxide dismutase activity and in photorespiration (Noctor *et al.*, 2000). Chloroplast peroxide production rates increase considerably when the main metabolic electron acceptors such as  $\text{CO}_2$  and  $\text{NO}_2^-$  are in short supply. To counteract redox imbalances and to detoxify reactive oxygen species (ROS), cells express a large set of proteins involved in (i) maintaining redox homeostasis, (ii) compensating redox imbalances, (iii) detoxifying reactive intermediates and (iv) repair of damaged macromolecules.

The main players in the plant antioxidant defence system are low molecular mass antioxidants, i.e. ascorbate, glutathione and tocopherol, and enzymes of the Halliwell-Asada cycle in combination with superoxide dismutase, and peroxisomal catalase (Asada, 2000) (Fig. 1). As will be shown below, chloroplast peroxiredoxins constitute an ascorbate-independent pathway for peroxide detoxification in the chloroplast, but also in other cell compartments. The Halliwell-Asada cycle employs ascorbate peroxidase for  $\text{H}_2\text{O}_2$  reduction linked to ascorbate oxidation and generation of monodehydroascorbate ( $2 \text{ Asc} + \text{H}_2\text{O}_2 \rightarrow 2 \text{ MDA} + 2 \text{ H}_2\text{O}$ ). MDA is either reduced via NADPH-dependent MDA reductase (MDAR) or following disproportionation of 2 MDA to Asc and dehydroascorbate (DHA) via dehydroascorbate reductase (DHAR) and linked to the glutathione oxidation ( $\text{DHA} + 2 \text{ GSH} \rightarrow \text{Asc} + \text{GSSG}$ ). GSSG is reduced at the expense of NADPH via glutathione reductase (GR). Since in photosynthesis, the electrons transferred to  $\text{O}_2$  derive from water splitting in the photosystem II-associated oxygen evolving complex, this hydrogen peroxide detoxifying cycle is also named ascorbate-dependent water/water cycle (Asada, 2006).

Since each of the enzymes involved in the water/water cycle is encoded through a gene family (7 SOD plus a Mn-SOD-like: Kliebenstein *et al.* 1998; 9 APX: Panchuk *et al.* 2005; 5 MDAR, 5 DHAR, 2 GR: Mittler *et al.*, 2004; 3 CAT: McClung 1997; 8 GPX) and some proteins reveal dual targeting to chloroplast and mitochondrion (Chew *et al.*, 2003), complete Halliwell/Asada cycles appear to exist in several subcellular compartments.

The identification of peroxiredoxins (Prxs) added a novel element to the complex plant antioxidant defence system. Exemplarily for the chloroplast detoxification of hydrogen peroxide, and as shown in Fig. 1, the four chloroplast peroxiredoxins (2-Cys PrxA, 2-Cys PrxB, PrxQ and Prx IIE) allow for an alternative water/water cycle independent of ascorbate (Dietz *et al.*, 2002; Dietz *et al.*, 2006a). However, the Prx proteins function not solely in chloroplast antioxidant defence. The review will focus on diversification of plant Prx structure, regulation and subcellular location. Work with transgenic plants, biochemical and physiological analyses and results from other species such as the resurrection plant *Xerophyta viscosa* have advanced our knowledge of plant Prxs. This indicates a function in intracellular signaling, which suggests future lines of research.

## 2. THE PRINCIPLE TYPES OF PEROXIREDOXINS BASED ON THEIR BIOCHEMICAL PROPERTIES

### 2.1. Plant Prx Classification

Each plant Prx polypeptide has a catalytical Cys in the more aminoterminally located part of the primary sequence that is also termed the peroxidatic thiol, (Cp) since it primarily interacts with the peroxide substrate. The catalytic Cys is oxidized to a sulfenic acid derivative. In general Prxs accept a broad range of peroxide substrates (Bréhélin *et al.*, 2003; König *et al.*, 2002; Lamkemeyer *et al.*, 2006; Rouhier *et al.*,

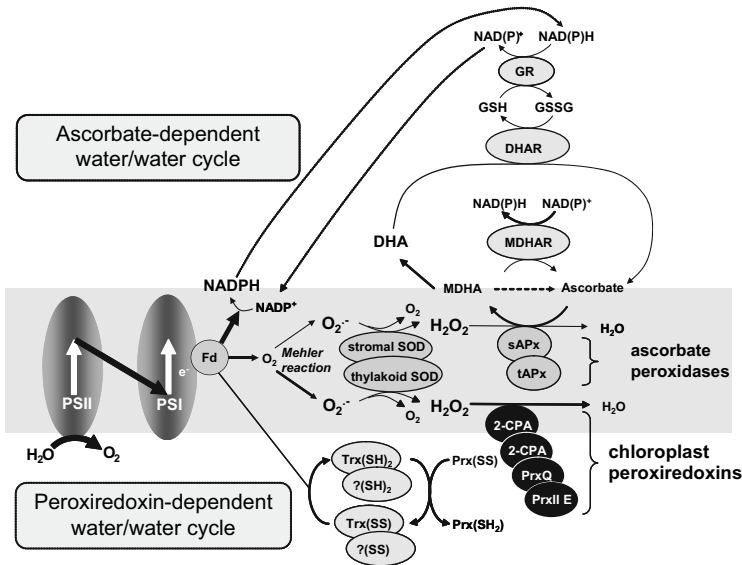

*Figure 1.* Ascorbate-dependent and -independent water/water cycle in plant chloroplasts. Photosynthesis of eukaryotes generates reactive oxygen species particularly at the acceptor site of photosystem I via transfer of electrons to oxygen. Following dismutation of superoxide anions to oxygen and hydrogenperoxide two alternative pathways decompose hydrogen peroxide. (i) The ascorbate-dependent pathway of the water/water cycle via thylakoid-bound and stromal ascorbate peroxidase reduces hydrogen peroxide at the expense of ascorbate. Oxidized mono-dehydroascorbate is either reduced or disproportionated to di-dehydroascorbate and ascorbate, the former being regenerated by coupling to glutathione as electron donor. (ii) The peroxiredoxin-dependent water/water cycle is ascorbate-independent. In *Arabidopsis* four Prx with distinct distribution among thylakoid and stroma catalyze the reaction. Oxidized Prx is regenerated by coupling to thiol-based electron donors such as Trx, Grx, cyclophilin or NTRC (see text for details)

2004a). The reaction of the peroxidatic thiol with hydrogen peroxide generates water, with alkyl hydroperoxides the corresponding alcohol, and with peroxynitrite nitrite. As will be pointed out below, the relative substrate preference of the various Prxs varies with the Prx isoform.

The nomenclature of peroxiredoxins lacks uniformity since two at least partly distinct classifications are commonly employed (see also Chapters 1 and 2). A distinction of three subgroups namely (typical or classical) 2-Cys Prx, atypical 2-Cys Prx, and 1-Cys Prx is often chosen in animal Prx classification (Rhee *et al.* 2005). Sequence similarities, the absence or presence and location of a second Cys residue named resolving Cys, and structural properties are used to group the Prx isoforms. Classical and atypical 2-Cys Prx each possess two Cys residues while 1-Cys Prx lack the resolving Cys (Dietz, 2003b). The classical 2-Cys Prx functions as homodimer in a head-to-tail arrangement where the sulfenic acid derivative of the peroxidatic Cys of one subunit interacts with the resolving Cys of the other subunit during the catalytic cycle (Baier *et al.*, 1997; Jang *et al.*, 2006). Thus, each dimer has

two catalytic centers. Atypical 2-Cys Prx carry both catalytic Cys within the same polypeptide subunit spaced by 4 or 24 amino acids (Rouhier *et al.*, 2002; Bréhélin *et al.*, 2003). According to the other nomenclature, the atypical 2-Cys Prxs are divided and the former are also named Prx Q or bacterioferritin comigratory protein (BCP) and the latter type II Prx (Hofmann *et al.*, 2002; Rouhier *et al.*, 2004b).

Recently, Rouhier and Jacquot (2005a) suggested that the gene family of plant glutathione peroxidases should be included as a fifth group of thioredoxin-dependent peroxidases. In contrast to animal glutathione peroxidases that following peroxide-mediated oxidation are regenerated using glutathione, plant glutathione peroxidase have a Cys as catalytic centre and were recently shown to possess a thioredoxin-dependent activity in plants, and are encoded by a small family of 7 genes (Rodriguez Milla *et al.*, 2003).

## 2.2. The Gene Family of Peroxiredoxins in Plants and Cyanobacteria

Since the detailed description of the peroxiredoxin gene family from *Arabidopsis thaliana* (Horling *et al.*, 2003) two additional genomes of higher plants have to date been searched for the presence of peroxiredoxins i.e. *Oryza sativa* (rice) and *Populus trichocarpa* (poplar) (Dietz *et al.*, 2006a; Rouhier *et al.*, 2006) (Table 1). In addition a comprehensive genome-based Prx inventory has been published for two cyanobacteria, *Synechocystis* PCC 6803 and *Synechococcus elongatus* (Stork *et al.*, 2005). Cyanobacteria represent the phylogenetic group where oxygenic photosynthesis evolved 3.5 billion years ago. They are related to the ancestor of the former photoendosymbiont which later on turned into the chloroplast of plants. The comparison of cyanobacteria with plants provides evolutionary hints on the peroxiredoxin requirements in context of photosynthesis. Table 1 presents the data from this analysis.

Table 1. Prx gene families in three higher plants and two cyanobacteria. The data are taken from Horling *et al.*, (2003: *Arabidopsis thaliana*), Dietz *et al.*, (2006a: *Oryza sativa*), Rouhier *et al.*, (2006: *Populus trichocarpa*) and Stork *et al.*, (2005: *Synechococcus elongatus*; *Synechocystis* PCC 6803)

Prx Species	<i>Arabidopsis thaliana</i>	<i>Oryza sativa</i>	<i>Populus trichocarpa</i>	<i>Synechococcus elongatus</i>	<i>Synechocystis</i> PCC 6803
1-Cys Prx	1	2	1	1	1
2-Cys Prx	2	1	2	1	1
Prx Q	1	1 <sup>a</sup>	2	2 <sup>c</sup>	4 <sup>d</sup>
Prx II/cytosol	4 <sup>b</sup>	1	2	1	0
Prx II/mitoch.	1	1	1		
Prx II/plastid	1	2	1		
Total	10 <sup>b</sup>	8	9	5	6

<sup>a</sup> two predicted and cDNA-verified variants from alternative splice sites;

<sup>b</sup> expression of Prx IIA is uncertain;

<sup>c</sup> both Prx Q lack second Cys;

<sup>d</sup> one Prx Q lacks second Cys.

The genomes of the three sequenced higher plants encode at least one 1-Cys Prx, one 2-Cys Prx, one Prx Q, and three PrxII, one of each localized in the cytosol, mitochondrion and plastid, respectively. Thus, the minimum Prx inventory in plants appears to consist of 6 Prx, three of which are targeted to the plastid. This highlights the importance of Prxs function in context of photosynthetic metabolism that will be discussed below. Within this basic pattern, genomic variation has led to single or repeated duplications, for example in the case of Prx IIE in rice, 2-Cys Prx A and B in *Arabidopsis thaliana* or possibly in dicotyledoneous species in general, since poplar also contains two 2-Cys Prx genes (Rouhier *et al.*, 2006) as well as the cytosolic type II Prx B, C (and D) in the dicotyledoneous species, respectively. The two cyanobacterial genomes contain each one 1-Cys Prx and 2-Cys Prx with high similarity to the higher plant orthologues, and a less conserved PrxQ. The type II Prx is facultative, and possibly Prx Q may substitute for Prx II in *Synechococcus elongatus* (Stork *et al.*, 2005).

### 3. CATALYTIC FUNCTION AND REGENERATION OF PLANT PRX

#### 3.1. Peroxide Substrates of Peroxiredoxins

Substrate specificity, turnover number and catalytic efficiency of plant peroxiredoxins have been studied repeatedly (for review see: Dietz *et al.*, 2006). The data do not reveal a clear, uniform and final picture, partly due to the lack of knowledge of the *in vivo* reducing partner for some Prxs (see below). By the rule of the thumb type II Prxs have the highest efficiency with up to 300 mol H<sub>2</sub>O<sub>2</sub> reduced per mol enzyme and min in the presence of the artificial regenerant dithiothreitol (DTT) (Bréhélin *et al.*, 2003; Horling *et al.*, 2002, 2003; Rouhier *et al.*, 2001, Jacob S and Dietz KJ, unpublished). Prx II prefer H<sub>2</sub>O<sub>2</sub> over lipid hydroperoxides; for instance the order of preference was 156 mol/(mol min) for H<sub>2</sub>O<sub>2</sub>, 126 for phosphatidylcholine hydroperoxide (PLOOH), 90 for t-butylhydroperoxide (tBOOH) and 54 for cumene hydroperoxide (COOH) (Rouhier *et al.*, 2004a). Activities of 1-Cys Prx and 2-Cys Prx are very low. With DTT, one molecule of *At*2-Cys Prx decomposes as little as 1–6 molecules of H<sub>2</sub>O<sub>2</sub> per minute in the presence of DTT (Horling *et al.*, 2002; König *et al.*, 2003). The activity increases about 10-fold in the presence of the most efficient thioredoxins identified so far (Collin *et al.*, 2003). The order of substrate preference was roughly correlated with the size of the peroxide substrate, i.e. the rates compared as follows: H<sub>2</sub>O<sub>2</sub> = tBOOH > COOH > LOOH >> PLOOH (König *et al.*, 2003). In a converse manner, Prx Q reduced H<sub>2</sub>O<sub>2</sub> = COOH >> tBOOH >>> LOOH with no detectable activity with PLOOH (Lamkemeyer *et al.*, 2006). Bryk *et al.* (2000) assigned a peroxynitrite reductase activity to the 2-Cys Prx homologue AhpC of bacteria. As revealed later on for the animal peroxiredoxins, the plant 2-Cys Prx also detoxifies peroxynitrite. This was shown (i) by complementation of the nitrite-sensitive yeast strain *tsa1Δtsa2Δ* by *At*2-Cys Prx and (ii) in an enzymatic test where reduced 2-Cys Prx inhibited

the peroxinitrite-dependent formation of rhodamine from dihydrorhodamine, as measured by fluorescence increase (Sakamoto *et al.*, 2003). Peroxinitrite reductase activity was also detected with the type II peroxiredoxin *AtPrxII E* (Laxa M, Dietz KJ, unpublished).

### 3.2. Reduction of 2-Cys Prx

Following the reaction with the peroxide substrates the Prx protein either persists in the state of the sulfenic acid form until reductive regeneration as in the case of the 1-Cys Prx or the genetically mutated mono-cysteinic variants of the 2-Cys Prx, PrxQ and PrxII whose resolving Cys-residue has been replaced. Interestingly, there exist monocysteinic variants of type II Prx and Prx Q (Stork *et al.*, 2005). Alternatively, an intra- or intermolecular disulfide bridge is rapidly established between the peroxidatic and the resolving Cys residue. In both cases, the active reduced form needs to be regenerated from the oxidized form before the next catalytic cycle may start. A large set of diverse interacting reducing partners has been identified in plants. In fact, the divergence of identified reductive regenerants in plants exceeds that of any other organismic group. Various typical thioredoxins, glutaredoxins, cyclophilins, glutathione, the chloroplastic NTRC and the CDSP32 protein are involved in the regeneration of distinct plant Prxs.

#### 3.2.1. Typical thioredoxins

Initially Trx-dependent peroxidase activity was shown for the 2-Cys Prx of *Synechocystis* PCC 6803 using *E. coli* Trx as electron donor (Yamamoto *et al.*, 1999). The first detailed comparative analysis in a homologous system with chloroplast Prx and Trx of *Arabidopsis thaliana* was reported by Collin *et al.* (2003). In *Arabidopsis thaliana* 9 Trx isoforms contain plastid targeting addresses, i.e. *AtTrx-f1*, *f2*, *m1-4*, *x*, *y1* and *y2* (Meyer *et al.* 2005), 7 of which had been described at the time of the study of Collin *et al.* (2003). Both the  $K_M$  and the turnover number were highest for the redox couple *AtTrx-x/2-Cys Prx*. Activity with *AtTrx-f1* > *m1* > *f2* was also significant, while no peroxidase activity was detected with *AtTrx-m3*. The work by Collin *et al.* (2003) gave first evidence for a distinct specificity in electron transfer from thioredoxin isoforms to Prx. Despite this seminal work, electron transfer to 2-Cys Prx is still not unequivocally resolved since three additional pathways have been described.

#### 3.2.2. CDSP, an atypical chloroplast Trx

CDSP32 was identified as a drought-induced protein in potato (Pruvot *et al.* 1996). After mutagenization of the resolving Cys Broin *et al.* (2002) immobilized the dual Trx-domain protein CDSP32 on a chromatographic column in order to isolate interacting redox partners. Using this covalent thiol protein trapping approach, often used in redox proteomics (Ströher and Dietz, 2006), the chloroplast 2-Cys Prx was isolated and identified as target of the CDSP32 protein (Broin *et al.*, 2002). 2-Cys Prx exists in four states that can be distinguished

through their electrophoretic mobility. In the presence of SDS the fully reduced dimer separates into monomers and shows a molecular mass of about 24 kD in non-reducing SDS PAGE. The two different disulfide forms approximate the electrophoretic mobility of the dimer, where the fully oxidized form with two intermolecular disulfide bridges runs faster than the form with only a single disulfide linkage. In addition, the overoxidized sulfinic acid form separates as monomer since no disulfide bridges can then be formed. Transgenic potato deficient in the CDSP32 protein showed a strongly increased fraction of monomers interpreted as the overoxidized form (Broin *et al.*, 2003). Covalent thiol modification with 4-acetamido-4'-maleimidylstilbene-2, 2'-disulfonic acid (AMS) allows one to distinguish the reduced and overoxidized forms. In addition, thermoluminescence indicated an increased level of lipid peroxidation. The authors concluded that CDSP32 is a critical element in the antioxidant defense against lipid peroxidation and that this capacity is linked to the reduction of the chloroplast 2-Cys Prx (Broin and Rey, 2003). It should be noted that the rate of hydrogen peroxide reduction catalyzed by the CDSP32/2-Cys Prx couple was extremely low with less than 1 catalytic cycle per min (Broin *et al.*, 2002).

### 3.2.3. *NTRC, a novel NADPH-dependent thioredoxin reductase*

Serrato *et al.* (2004) recently described the chloroplast protein NTRC to efficiently reduce 2-Cys Prx with NADPH as source of reducing power (Pérez-Ruiz *et al.*, 2006). NTRC is a dual domain protein with a Trx reductase domain and a Trx domain. An Arabidopsis mutant deficient in NTRC shows the phenotype of slow growth, low seed production and hypersensitivity to abiotic stress (Serrato *et al.* 2004). NTRC deficient mutants exhibit redox imbalances of the chloroplastic 2-Cys Prx. The transgenic plants also have an altered photosynthetic phenotype suggesting an important function of NTRC for plant growth, adaptation to the environment and maintenance of high productivity (Pérez-Ruiz *et al.*, 2006).

### 3.2.4. *Cyclophilin Cyp20-3*

In an overlay assay a 20 kD polypeptide was detected as binding partner of human Prdx6 and identified as cyclophilin A (CyP-A) (Lee *et al.*, 2001). Cyclophilins constitute a subgroup within the (super-)family of peptidyl-prolyl-*cis/trans*-isomerases (PPIase) accelerating the isomerisation of prolyl linkages in protein backbones. This reaction often is the rate-limiting step in correct folding of nascent proteins. In addition to their role in protein folding and maturation, PPIases have chaperone functions. In biochemical peroxidase assays HsCyPA supported the antioxidant activity of the mammalian Prx isoforms (Lee *et al.*, 2001). HsCypA has significant similarity to cyclophilins of plants. Plant cyclophilins contain conserved Cys groups (Romano *et al.*, 2004), for example Cyp20-3 carries four Cys residues. Cyp20-3 reduces both isoforms of At2-Cys Prx A and B as shown by DNA protection assays and peroxidase assays (Laxa *et al.*, 2006). Significant activity was not seen with AtPrxQ and AtPrxII E.

### 3.2.5. Sulfiredoxin

Sulfiredoxins were first identified in yeast and subsequently in mammals (Biteau *et al.*, 2003; Chang *et al.*, 2004). In a slow reaction, sulfiredoxins reduce sulfinic acid residues of proteins in the presence of thiol, ATP and Mg. A high specificity of human sulfiredoxin HsSrx for 2-Cys Prx was shown by Woo *et al.* (2005). HsSrx regenerates all four human 2-Cys Prx (*HsPrdx1-4*) but reveals no sulfinic acid reduction activity with sulfinic acid forms of type II Prx (*HsPrdx5*), 1-Cys Prx (*HsPrdx6*) and glyceraldehyde-3-phosphate dehydrogenase (GAPDH). The genomes of plants also encode a sulfiredoxin gene. The single *AtSrx* gene (*At1g31170*) in *Arabidopsis* encodes a 14 kD polypeptide with targeting address to the plastids. *AtSrx* reduces the sulfinic acid form of *At*-2-Cys Prx (Liu *et al.*, 2006; Rey *et al.*, 2006). The level of over-oxidized 2-Cys Prx increases in transgenic plants with low or no *AtSrx* protein, under stress. Sensitivity of these plants to methylviologen increases (Liu *et al.*, 2006), while in another study the knock down/out plants reveal increased tolerance to photo-oxidative stress elicited by high light and low temperature (Rey *et al.*, 2006). Apparently the physiological significance of the Srx/2-Cys Prx-system and expression of altered phenotype upon Srx-deletion, respectively, depend on the type of oxidative stress administered to the plants.

In summary there exist four pathways for 2-Cys Prx reduction in chloroplasts and additionally a salvation pathway for the overoxidized sulfinic acid form of 2-Cys Prx (Fig. 2). Reduction of the disulfide form via the FTR/Trx pathway occurs (i) via classical Trx and (ii) via CDSP32, respectively, which both use photosynthetically reduced ferredoxin and are linked to photosynthetic light energy conversion. (iii) In addition the NTRC-dependent pathway uses NADPH as source of reducing power and functions in a light-independent manner. At low light and in darkness when reduced ferredoxin (Fd) is limiting, the activity of the NTRC pathway may come into play and maintains 2-Cys Prx in a reduced state (Pérez-Ruiz *et al.*, 2006). This newly discovered reduction pathway provides an explanation for the presence of partly reduced 2-Cys Prx in the dark. The presence of reduced 2-Cys Prx in the dark was an early observation (Baier and Dietz, 1997) which was difficult to reconcile with the hypothesis that light-driven photosynthetic electron transport solely acts as reductive pathway. (iv) Interestingly, the chloroplast cyclophilin Cyp20-3 maintains the catalytic cycle of 2-Cys Prx as well. The physiological significance of this finding remains elusive. Alternative to a function in reduction of oxidized Prx, the redox state of Prx could feed back on the redox state of Cyp20-3 and thereby modulate the activity of the cyclophilin. (v) In addition, sulfiredoxins regenerate over-oxidized 2-Cys Prx at low rates.

It is quite obvious that 2-Cys Prx is tied into a complex network of redox reactions. This explains the extraordinarily high degree of conservation of the primary sequence and structure of 2-Cys Prx among all photosynthetic organisms.



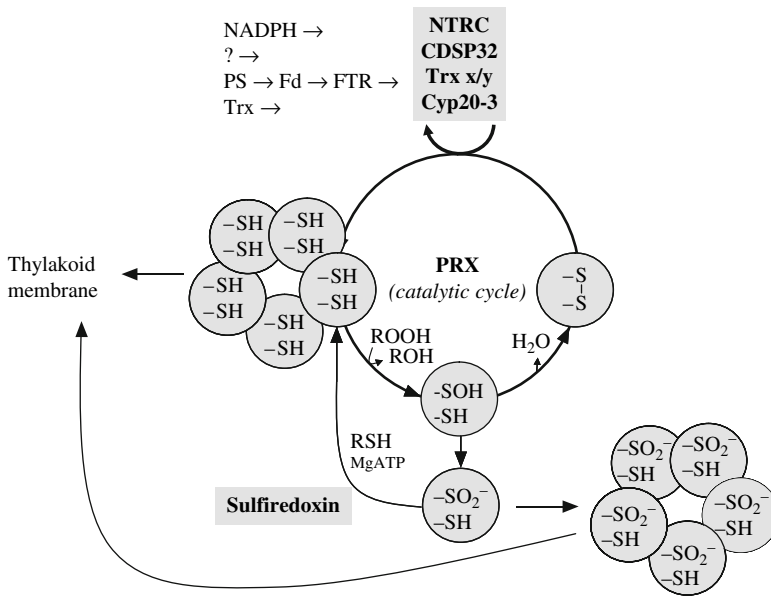

**Figure 2.** Linkage of 2-Cys Prx within the chloroplast redox network. The chloroplast 2-Cys Prx (grey circle) has two catalytic thiols that are involved in the catalytic cycle. The peroxidatic thiol exists in the thiol, sulfenic acid and sulfinic acid form, respectively. 2-Cys Prx acquires different conformation states and interacts with a set of diverse thiol and non-thiol proteins. See text for details: NTRC: NADPH-dependent dual domain protein reducing 2-Cys Prx; CDSP32: drought induced Trx like protein; PS: photosynthesis; Fd ferredoxin; FTR: Fd-dependent Trx reductase; Cyp20-3: chloroplast cyclophilin

### 3.3. Reduction of PrxQ

Kong *et al.* (2000) isolated the *S*PrxQ cDNA from the Crassulacean plant *Sedum lineare* and characterized this novel 17 kDa plant peroxiredoxin with significant similarity to the bacterial bacterioferritin comigratory protein (Bcp). *S*PrxQ decomposes *t*-butylhydroperoxide and cumene hydroperoxide in an assay containing *E. coli* thioredoxin, *E. coli* thioredoxin reductase and NADPH. The result showed that this novel plant peroxiredoxin named PrxQ belongs to the thioredoxin-independent peroxidases. In that study, the sequence was truncated at its N-terminus and lacked the transit peptide for plastid import (Kong *et al.*, 2000). Following the identification of the plastid targeting sequence (Horling *et al.*, 2002), Collin *et al.* (2004) investigated the efficiency of the various plastid thioredoxins in reducing oxidized *At*PrxQ. *At*Trx-y1 most efficiently regenerated PrxQ. *At*Trx-y2 > x > m4 also significantly reduced PrxQ<sub>ox</sub>, while the other tested plastid Trx exhibited low or no activity. NASC array database analysis reveals that, while *At*trx-y1 is co-expressed with *AtprxQ*, transcript level regulation of *At*trx-y2 lacks any correlation with *AtprxQ* transcript abundance (Collin *et al.*, 2004), suggesting that indeed *At*Trx-y1 and *At*PrxQ represent a functional and specific redox couple.

### 3.4. 1-Cys Prx

Even though 10 years have passed since the first description of the barley 1-Cys Prx in 1996 (Stacy *et al.*, 1996) and the general occurrence of 1-Cys Prx in animals, fungi and plants, the physiological electron donor is still unknown. In contrast to eukaryotic 2-Cys Prx where the sulfenic intermediate of the peroxidatic Cys is sensitive to overoxidation, the crystal structure of human 1-Cys Prx reveals a stable sulfenic acid intermediate inaccessible for solvents (Choi *et al.*, 1998). The reduction of 1-Cys Prx probably depends on local unfolding to allow the unknown reductant to access the buried sulfenic acid residue (Wood *et al.*, 2003).

### 3.5. PrxII

Rouhier *et al.* (2001) isolated a type II peroxiredoxin *PtPrxII* from poplar that accepted electrons both from thioredoxins and glutaredoxins. *PtPrxII* lacks the C-terminally located homologue of Cys-152 in human type II Prx *HsPrdxV* that exclusively accepts electrons from Trx. Introducing this additional Cys residue in the plant Prx enzyme abolished its ability to accept electron from Grx while the Trx-dependent activity was conserved (Rouhier *et al.*, 2002). Unlike *PtPrxII*, neither the cytosolic *AtPrxII B* nor the chloroplastic *AtPrxII E* were active peroxidases in the presence of a Trx system, while the Grx system supported the peroxide reduction activity of both enzymes (Bréhélin *et al.*, 2003). In a proteomic screen for Grx-redox partners Rouhier *et al.*, (2005) took advantage of the thiol trapping mechanism in the absence of the resolving Cys residue. The proteins covalently bound to the Cys30Ser Grx variant immobilized to the chromatographic material were eluted and analyzed by mass spectrometry. Five peroxiredoxins, namely *At2-Cys Prx*, *AtPrxQ*, *AtPrxII B*, *AtPrxII E* and *AtPrxII F*, were among the identified 94 targets. In a subsequent enzymatic test, the mitochondrial *AtPrxII F* revealed peroxidase activity in the presence of the Grx system while *At2-Cys Prx* was inactive (Rouhier *et al.*, 2005). This is in agreement with another study where mitochondrial Grx supported peroxidase activity of *AtPrxII F* (Finkemeier *et al.*, 2005). In this study, GSH also showed some ability to reduce oxidized *AtPrxII F*.

## 4. TRANSCRIPT REGULATION OF PRX-GENES AND PROTEIN ACCUMULATION

In addition to the functional differentiation of the Prx protein family in terms of substrate, regenerant and subcellular localisation, the transcriptional regulation in response to developmental and environmental cues adds another level of exciting diversity. Prx transcript level regulation has been studied both in targeted approaches and through whole genome experiments by cDNA array hybridisation. Now, 10 years after the first description of a *Hv1-Cys Prx* and a *Hv2-Cys Prx* gene in barley (Stacy *et al.*, 1996; Baier and Dietz, 1996), Prxs are acknowledged members of the enzymatic antioxidant defence system of plants and their regulation and function have been addressed and discussed in an increasing number of studies.

#### 4.1. Tissue Specificity of Expression

Some of the peroxiredoxin transcripts have been detected in all analyzed plant tissues, however the expression of each individual member of the *prx* gene family may vary considerably. For the time being it appears to be a justified statement that there are no cells without peroxiredoxins. A highly specific expression is reported for *Hv1-cys prx* in *Hordeum vulgare* (barley) and *Arabidopsis*. *Hv1-Cys Prx* is found in the aleuron layer and the embryo of desiccating seeds (Stacy *et al.*, 1996). Likewise, *At1-Cys Prx* was found in seeds of *Arabidopsis thaliana*. Expression of *At1-cys prx* during early seed development is suggested to depend on a putative antioxidant-responsive promoter element (ARE), while during later stages endosperm- and embryo-specific gene expression is linked to an abscisic acid (ABA)-responsive element (ABRE) likely to bind ABI5. ABI5 is a transcription factor belonging to the basic leucine zipper factors that bind to conserved cis-acting ABA-responsive elements (Haslekas *et al.*, 1998).

The accumulation of transcripts encoding chloroplastic *prx* shows a correlation with chlorophyll both in tissue distribution and during leaf development. This co-regulation is most significant for the *At2-cys prx* and the *AtprxQ* and least for *AtprxII E* (Dietz *et al.*, 2005). The pattern supports the conclusion that 2-Cys Prx and PrxQ function in immediate context of photosynthesis while PrxII E might have a house-keeping antioxidant function in plastids (Dietz *et al.*, 2006b). In contrast to the expression of *AtprxQ*, *GtprxQ* the PrxQ-homologue of *Gentiana triflora* was maximally expressed in shoots, also high in roots and lowest in leaves (Kiba *et al.*, 2005).

Type II Prxs have a highly divergent distribution (Horling *et al.*, 2002; Bréhélin *et al.*, 2003). The mitochondrial *AtprxII F* transcript is detected in all tissues at similar levels when normalized on identical actin transcript amounts. The cytosolic *AtprxII C* and *AtprxII D* transcript are not present or detected only at very low levels in roots, stems, leaves and calli. Detectable amounts were seen in seeds, siliques, seedlings and buds, and highest in flowers (Bréhélin *et al.*, 2003). *AtprxII B* mRNA was detected by semiquantitative RT PCR in all tissues with maximal levels in seeds, followed by calli, suspended liquid-cultured cells and siliques (Bréhélin *et al.*, 2003). Apparently, the assumed gene duplication events during development of *Arabidopsis* were coupled to a divergence of gene expression profile of the highly similar three genes *AtprxII B*, *C* and *D*. It will be interesting to analyse the expression of the two poplar and single rice type II Prx genes with predicted cytosolic location in order to distinguish the peculiarity of *Arabidopsis* and the general requirement of plant cell metabolism for the presence of cytosolic type II Prx.

#### 4.2. Transcript Regulation in Mutants and under Oxidative Stress Deduced from Array Hybridisations

Recently antioxidant gene expression was compared using hybridisation of the ATH1 Affimetrix cDNA chip of *Arabidopsis thaliana*. One study included three mutants with defects in single elements of the antioxidant defence system,

i.e. antisense catalase, knock-out APX1 (lacking one ascorbate peroxidase isoform) and knock-out CSD2 plants (lacking one Cu/Zn superoxide dismutase isoform), as well as five stress regimes with impact on the antioxidant state, i.e. heat, drought, salinity, cold and high light, that are known to induce oxidative stress (Mittler *et al.*, 2004). The study revealed distinct regulation of the various elements of the antioxidant system of plants and also for the members of the *Atprx* family. The chloroplast *prxQ* was strongly up-regulated under heat, salt and cold stress, while the chloroplast 2-Cys Prx mRNA increased in plants with decreased catalase activity and upon heat stress. The expression of the cytosolic *Atprx B* was up-regulated upon administration of various oxidative stresses, and the cytosolic *AtprxII C* and *D* under saline growth conditions. The plastidic *AtprxII E* responded to 5 out of 8 oxidative stress regimes, however in contrast to *Atprx IIB* (Mittler *et al.*, 2004). Interestingly, down-regulation of *prx* transcript amounts was seen under most other conditions. Array analysis indicated down-regulation of *At2-cys prxA* and *B*, *AtprxQ* and *AtprxII E* but upregulation of mRNA encoding *AtprxII F* upon pathogen infection similar to ozone (Dietz *et al.*, 2006a). These studies reveal specificity of Prx gene expression regulation with often similar response pattern of the plastid-targeted Prx transcripts.

### 4.3. Transcript Regulation under Abiotic Stresses

A strong responsiveness of *prx* transcripts in *Arabidopsis thaliana* to environmental cues as well as to effectors of oxidative stress was observed in various studies specifically aiming at characterizing the response of Prx genes.

#### 4.3.1. Light

In their natural environment plants face continuous changes in photon flux density. Full sunlight in temperate regions corresponds to about 2000  $\mu\text{mol}$  quanta  $\text{m}^{-2}\text{s}^{-1}$  (200  $\text{Wm}^{-2}$ ). Day-night transition, clouds and shading cause major alteration of incident light often with quite fast kinetics. Such changes cause redox imbalances and oxidative stress, and induce compensatory regulation also at the level of gene expression (Pfannschmidt *et al.*, 2003). Plants have evolved acclimatory mechanisms in order to optimize the use of excitation energy at low excitation level and to allow for dissipation of excess energy at high light intensity. As outlined above, the photosynthetic electron transport chain also transfers electrons to oxygen. This Mehler reaction generates reactive oxygen species as depicted in Fig. 1 and enables to relieve inter-system electron pressure. In this context, the light response of Prx gene expression has been investigated. Low light decreased transcript levels of the chloroplast *At2-cys prxA*, *At2-cys-prxB* and *AtprxQ*, but also of the cytosolic *AtprxII B*, while the transcripts for chloroplast *AtprxII E* and mitochondrial *AtprxII F* remained unchanged. In a converse manner and from a very low steady state level, the cytosolic *AtprxII C* showed a transient upregulation (Horling *et al.*, 2003). Transfer from 120  $\mu\text{mol}$  quanta  $\text{m}^{-2}\text{s}^{-1}$  to high light of 1000  $\mu\text{mol}$  quanta  $\text{m}^{-2}\text{s}^{-1}$  elicited up-regulation particularly of chloroplast *At2-cys*

*prxB*, *Atprx Q* and *AtprxII E*. The regulatory dynamics is mostly in line with cDNA array results where high light induced the strongest up-regulation of the *AtprxQ* transcript, less of *At2-cys prxB* while *At2-cys prxA* and *AtprxII E* hybridisation strength was unaltered (Dietz *et al.*, 2006a). This example exemplifies the high dynamics of *prx* transcript regulation also observed in response to changes of many other external parameters.

#### 4.3.2. Salinity

Treatment of *Arabidopsis* leaf slices with NaCl resulted in a general down-regulation of all four chloroplast *prx* transcripts while transcript levels of the cytosolic *AtprxII*, in particular *AtprxII C* were strongly elevated (Horling *et al.*, 2002). The decrease in mRNA abundance encoding plastid *prx* was confirmed by cDNA array results (Dietz *et al.*, 2006a; Mittler *et al.*, 2004). In contrast to higher plants, several *prx*-transcripts including those of 2-Cys Prx accumulated upon salt treatment of the cyanobacteria *Synechocystis PCC6803* and *Synechococcus elongatus* (Stork *et al.*, 2005).

#### 4.3.3. Nutrient deficiency

Depending on the nutritional state at the site of germination plants often have to grow and develop in a nutrient-poor habitat. Nutrient deficiencies in nitrogen, phosphorous and to a lesser extent sulphur are frequently encountered and cause major adaptive responses (Kandlbinder *et al.*, 2004). The redox state of phosphate-deprived *Arabidopsis thaliana* leaves was strongly altered as indicated by increased ascorbate and glutathione levels and stimulated activities of APX and CAT. In accordance with this result, transcripts of all *cat* genes and stromal *apx*, and particularly of the cytosolic peroxiredoxins *AtPrxII C* and *PrxIID*, were elevated under P deprivation (Kandlbinder *et al.*, 2004).

#### 4.3.4. Heavy metal toxicity

A set of metals such as Cd, Cu and Ni is highly toxic at low or below micromolar concentrations. An increasing body of evidence links metal toxicity to severe disturbances of cellular redox balance and oxidative stress (Dietz *et al.*, 1999). Only a few studies have investigated the transcriptional response of *prx* genes to heavy metal stress. The mitochondrial *AtprxII F* is up-regulated upon treating *Arabidopsis thaliana* with CdCl<sub>2</sub> (Finkemeier *et al.*, 2005). In agreement with the transcriptional up-regulation, root growth of PrxII F knock-out lines is inhibited in the presence of 10 μM CdCl<sub>2</sub> to a much stronger extent than in wild-type plants.

On the protein level, Cu stress induced the accumulation of PrxQ in leaves both of *Arabidopsis thaliana* and *Arabidopsis halleri*. The latter species is a Zn- and Cd-hyper-accumulating plant that tolerates exposure to very high Zn and also elevated Cd in the growth medium, while the sensitivity to Cu is similar (Bergmannshof, Finkemeier and Dietz, unpublished) (Fig. 3).

From hydroponically grown *Zea mays* exposed to arsenate either in the As(V) or As(III) form, root extracts were subjected to a proteome analysis after 2-dimensional

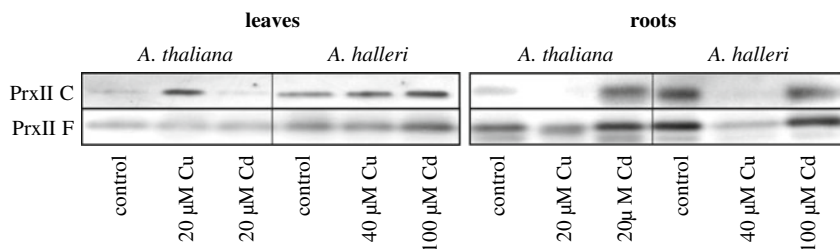

Figure 3. Prx protein amounts in Cu- and Cd-stressed metal-sensitive *Arabidopsis thaliana* and metal-tolerant *Arabidopsis halleri*. Hydroponically grown 4 week old *A. thaliana* were treated with either 20 μM CdCl<sub>2</sub> or CuCl<sub>2</sub>, while the more tolerant *A. halleri* plants were expose to 100 μM CdCl<sub>2</sub> and 40 μM CuCl<sub>2</sub>, respectively, for 1 week (I Bergmannshof, I Finkemeier, KJ Dietz unpublished). Leaf and root extract aliquots equivalent to identical protein amounts were separated by SDS PAGE and probed with anti PrxII C antibody and anti PrxII F antibody, respectively. Both the mitochondrial PrxII F and cytosolic PrxII C decreased in *A. th* roots upon Cu stress indicating severe oxidative stress. Both were slightly up in Cd-treated roots of both plants. In leaves, strong PrxII C accumulation under Cu stress was apparent. This example shows dynamic regulation of Prx protein amounts under heavy metal stress

gel separation (Requejo and Tena, 2005). The averaged normalized area of a specific spot #17, increased 2.6- and 5.6-fold, respectively, and was tentatively identified as Prx with similarity to PER1, the 1-Cys Prx (EC 1.11.1.15) of *Hordeum vulgare*. The precise nature of this particular As-regulated Prx still needs to be clarified. Since As is known to elicit oxidative stress in maize (Mylona *et al.*, 1998), a linkage between As exposure and altered Prx and glutathione peroxidase protein accumulation might be expected (Requejo and Tena, 2005).

The 2-cys *prx* transcript was mostly unresponsive to treatment with Zn, Cd and Ni (Baier and Dietz, 1997) and slightly increased in bean plants treated with HgCl<sub>2</sub> (Genot *et al.*, 2001).

#### 4.4. Regulation in Response to Pathogen Infection

Infection of poplar plants with the pathogenic fungus *Melampsora larici-populina* rapidly induced accumulation of *prxQ* transcript (Rouhier *et al.*, 2004b). Likewise transcript of *GtprxQ* responded to salicylic acid, a plant hormone mediating pathogen responses, but not to jasmonic acid, a plant hormone preferentially involved in wound response (Kiba *et al.*, 2005). Interestingly, *GtPrxQ* protein was characterized to inhibit bacterial growth (Kiba *et al.*, 2005) at concentrations similar to those detected in leaf tissues (Lamkemeyer *et al.*, 2006). Sequence similarity to Prx Q of other species ranged between 94% in case of *Populus trichocarpa* and 63% of *Arabidopsis thaliana* Prx Q. Overexpression of *AtAFP1* in tobacco plants

increased resistance to fungal disease as indicated by smaller lesions 5 d after inoculation of leaves with *Botrytis cinerea* and also elevated oxidative stress tolerance during paraquat treatment.

Protein levels of photosynthesis-related 2-Cys Prx was higher in a resistant *Brassica* genotype than in a sensitive genotype upon challenge with the fungal pathogen *Leptosphaeria maculans* (Subramanian *et al.*, 2005). It will have to be assessed whether this up-regulation in response to pathogens and plant hormone, respectively, involves the participation of reactive oxygen species as second messenger. Two investigations have linked the function of Prx Q to plant pathogen interaction. Kiba *et al.* (2005) purified the protein *GtAFP1* from *Gentiana triflora* (*Gentiana triflora* antifungal protein 1) leaves based on its antifungal activity. It inhibited fungal spore germination of *Alternaria alternata*, *Botrytis cinerea* and *Fusarium solani*.

## 4.5. Effector Studies

### 4.5.1. Peroxides

Exogenous application of hydrogen peroxide, *tert*-butyl hydroperoxide and the oxidizing agent diamide to leaf slices stimulated accumulation of plastid *AtprxQ* and *AtprxII C* transcript amounts (Horling *et al.*, 2003). The mRNA levels of chloroplast *2-cys prxA/B* and mitochondrial *prxII F* were unresponsive to the oxidizing treatments. Transcripts of *prxII E* slightly increased with hydrogen peroxide while that of *prxII B* went up with *tert*-butyl hydroperoxide. It can be concluded from this experiment that transcript accumulation of plant peroxidases is subject to a highly distinct and specific regulation in response to oxidative stressors.

### 4.5.2. Ascorbate

Ascorbate is the predominant non-enzymatic antioxidant in plants involved as cosubstrate in ROS detoxification via ascorbate peroxidase (see Fig. 1), in recycling of oxidized tocopheryl radical and as cofactor for violaxanthin de-epoxidase (Smirnoff, 2000). It also modifies nuclear gene expression (Pastori *et al.*, 2003). Feeding ascorbate to leaf slices strongly and rapidly affected *prx* transcript regulation (Horling *et al.*, 2003) and also expression of chloroplast *Rf2-cys prx* in the liverwort *Riccia fluitans* (Horling *et al.*, 2001). Transcripts of the chloroplast *prx* decreased in the order of response strength  $AtprxQ = At2-cys prx B > At2-cys prxA > AtprxIIE$  while *AtprxII C* mRNA amount increased. The suppression was fast and strong (Horling *et al.*, 2003). Using transgenic *Arabidopsis* lines expressing the luciferase reporter gene under control of the *2-cys prxA* promoter showed that the transcript regulation in response to ascorbate is due to transcriptional modulation of gene activity and is not caused by posttranscriptional control of mRNA stability.

#### 4.5.3. Response to plant hormones

Plant development and adaptation is controlled by a set of five classical and at least five additional, only more recently identified plant growth substances, only few of which have been analyzed in relation to their effect on *prx* gene expression. ABA often mediates adaptation to abiotic stressors through complex cross-talking signaling pathways (Himmelbach *et al.*, 2003). *At1-cys prx* transcript regulation during seed development is related to the plant stress hormone abscisic acid (ABA). Although *At1-cys prx* transcript amounts are unchanged in an ABA-deficient mutant (*aba-1*) compared to wild-type *At1-cys prx*, expression is reduced in the ABA-insensitive mutant (*abi3-1*) (Haslekas *et al.*, 2003). ABA is also a major component in the regulatory network controlling *At2-cys prx* expression (Baier *et al.*, 2004). Interestingly and in contrast to reasonable expectations in the light of ABA-mediated stress adaptation, ABA functions as a suppressor of *2-cys prx* expression as revealed from work with ABA-insensitive and ABA-deficient mutants combined with ABA feeding (Baier *et al.*, 2004). This observation links 2-Cys Prx to a function in regular photosynthesis rather than in stress response, since the plant hormone ABA has a central function in suppressing nuclear expression of chloroplast proteins (summarized in: Rook and Bevan, 2003). It was suggested that ABA acts as a downstream signal in carbohydrate signaling (Jang and Sheen, 1994), although now it has to be considered as an at least partly independent signaling pathway. From the data on *2-cys prx* gene regulation (Baier *et al.*, 2004) it was suggested that redox regulation feeds into the ABA-signaling pathway, i.e. oxidative stimuli negatively affect the ABA suppression pathway, leading to activation, while reducing conditions stimulate the ABA suppression pathway. Also, *At1-cys prx* transcript is not induced in vegetative tissue in response to ABA or drought stress. As outlined above, expression of *GtprxQ* is induced by treatment with salicylic acid, but not methyl jasmonate (Kiba *et al.*, 2005), an observation that has been linked to pathogen response. A more thorough analysis of available array hybridisation data and a comparative analysis is needed to reveal the relationship between plant hormones and *prx* gene expression in detail.

#### 4.5.4. Involved signaling cascades and promoter analysis

The realisation of the transcriptional changes depend on the generation and perception that appropriate signals and signal transduction to the *cis*-regulatory promoter sequences. In the case of organellar peroxiredoxins signaling between organelles and the nucleus is assumed (Baier and Dietz, 2005). Only few studies have addressed this topic of signaling in relation to peroxiredoxin expression. Regulation of the *2-cys prx* promoter (2CPA) is being investigated due to its rather unique features. Under regular growth conditions, expression is high. Down-regulation is observed under conditions of low electron pressure at PSI and after administration of antioxidants such as ascorbate and dithiothreitol (Baier and Dietz, 1997; Horling *et al.*, 2001). In this study, pre-treatment with staurosporin, an inhibitor of serine/threonine protein kinases prevented the ascorbate effect. It was concluded that a protein kinase participates in signal transduction. This was



confirmed after feeding more specific inhibitors of mitogen activated protein kinases (Baier *et al.*, 2004). In the latter study, the promoter region acting as target for redox regulation was narrowed down to a 270 bp fragment. At present the element is being identified and used as bait in a yeast-one-hybrid screen in order to reconstruct the signaling pathway from target-up (Jehad Shaik-Ali, Karl-Josef Dietz, Margarete Baier, unpublished).

## 5. PLANT PRX IN PHOTOSYNTHESIS

Detoxification of ROS generated in plant photosynthesis is a necessity to maintain functionality of the photosynthetic apparatus. The availability of the methods of molecular-genetics and the increasing number of complete genome sequences enable evolutionary perspectives by comparing the antioxidant defence systems of higher plants and cyanobacteria where oxygenic photosynthesis evolved.

### 5.1. Peroxiredoxins in Cyanobacterial Photosynthesis

Cyanobacteria suppress electron transfer from ferredoxin to O<sub>2</sub> at the acceptor site of photosystem I and may be devoid of the Mehler reaction (Helman *et al.*, 2003). Interestingly, cyanobacteria lack ascorbate peroxidases that evolved only later during plant evolution, possibly by diverging from mitochondrial cytochrome c peroxidase (Bakalovic *et al.*, 2006). Cyanobacterial genomes encode the heme containing bifunctional catalase/peroxidase KatG that decomposes H<sub>2</sub>O<sub>2</sub> either by disproportionation like catalases or by reduction using an organic electron donor (KatG) (Mutsuda *et al.*, 1996). In addition they encode a set of 5 to 6 peroxiredoxins (Stork *et al.*, 2005). *Synechocystis PCC 6803* with an insertionally inactivated 2-*cys prx* gene showed some growth inhibition in high light under stress (Klughammer *et al.*, 1998). The mutant was unable to utilize H<sub>2</sub>O<sub>2</sub> as electron acceptor (Yamamoto *et al.*, 1999). The double mutant lacking functional *katG* and 2-*cys prx* proved the function of 2-Cys Prx in antioxidant defence (Nishiyama *et al.*, 2001). Upon H<sub>2</sub>O<sub>2</sub> treatment the double mutant revealed accelerated photoinhibition and photodamage. The large number of peroxiredoxin genes in cyanobacterial genomes as compared to heterotrophic bacteria and the high degree of conservation of 2-Cys Prx suggests a specific function in the context of oxygen photosynthesis.

### 5.2. Peroxiredoxins in Plant Photosynthesis

In *Arabidopsis*, four Prxs out of 10 encoded in the genome are targeted to the chloroplast. A genome-wide database search for *prx* genes in cyanobacteria, the bacterial group where oxygenic photosynthesis first evolved, revealed the presence of at least one 2-Cys Prx, one 1-Cys Prx and one PrxQ, while type II Prx was either present (*Synechocystis* 6803) or absent (*Synechococcus elongatus* 7942). Likewise, each analyzed higher plant genome was shown to contain one or two of each plastid Prx, i.e. 2-Cys Prx, Prx Q and PrxIIE, respectively (Dietz *et al.*, 2006a). From

this comparison it can be concluded that oxygenic photosynthesis is linked to three different types of Prxs. Interestingly, each of these Prxs has a distinct sub-organellar distribution (Dietz *et al.*, 2006a). PrxQ is mostly attached to the thylakoid membrane (Lamkemeyer *et al.*, 2006). Fractionation of the thylakoid complexes suggests that Prx Q is at least partly associated with photosystem II. 2-Cys Prx undergoes major conformational changes depending on the redox state. The oxidized disulfide form is soluble in the stroma. The fully reduced and over-oxidized form converts to the decameric structure and attaches to the thylakoid membrane (König *et al.*, 2002, 2003). A cycle of attachment and dissociation is established which depends on the redox-related conformation state. PrxII E is mostly or exclusively found in the stroma (Dietz *et al.*, 2006b). Recently, Meissner *et al.* (2006) reported the existence of a dodecahydral arrangement of the erythrocyte 2-Cys Prx decamer. This  $3 \cdot 10^6$  Da supercomplex adds a new level of conformational complexity to the Prx system. It will have to be investigated whether the observed high molecular mass assemblies of plant 2-Cys Prx also represent this type of superstructure. In accordance with the distinct distribution, specific functions have tentatively been assigned to the chloroplast Prx isoforms. PrxII E may be responsible to quench peroxides, particularly hydrogen peroxide, escaping from the thylakoid-bound APx-dependent defence systems. As described in the introduction, many enzymes of the Calvin cycle and other thiol/disulfide proteins are sensitive targets to oxidation (Buchanan and Balmer, 2005). PrxQ might be involved in detoxifying peroxides at the thylakoid membrane similar to the thylakoid-bound tAPx. tAPx is associated with photosystem I (Miyake and Asada, 1992). Albeit that tAPx is an efficient and site-specific scavenging system, some peroxide is likely to be released from photosystem I and may damage other protein targets at the thylakoid membrane. The association of PrxQ with photosystem II might protect this particular reaction center (Lamkemeyer *et al.*, 2006). The lack of PrxQ in transgenic *Arabidopsis thaliana* induces a small but significant change in photosynthetic protein complex stoichiometry with a significant decrease in photosystem II amount. At present, the picture of the role of peroxiredoxins in photosynthesis is only slowly emerging. The lack of major alterations of phenotype and the small physiological changes observed in mutants lacking single chloroplast peroxiredoxins may be surprising in the light of the high protein fraction represented by 2-Cys Prx (0.6% of chloroplast protein; König *et al.*, 2002) and Prx Q (0.3%; Lamkemeyer *et al.*, 2006). Apparently, activation of compensatory mechanisms alleviates the deficiency. Similar experiments as described above will have to be performed with PrxII E-knock-out/down plants and for double and triple *prx* mutants.

## 6. PRX IN PLANT DEVELOPMENT

Haslekas *et al.*, (2003) constructed *Arabidopsis* lines expressing glucuronidase under the control of truncated *At1-cys prx* promoter fragments. Promoter activity was detected in the endosperm, especially the chalazal cyst, when the embryo reaches the late globular stage, and also in the embryo from the late torpedo stage, and in distinct

cells of unfertilized and fertilized ovules (Haslekas *et al.*, 2003). Early expression of *At1-cys prx* is suggested to rely on a putative antioxidant-responsive promoter element (ARE). Later during seed development, i.e. from the bent cotyledon stage on, transcript accumulation in the endosperm and embryo depends on an ABA-responsive element (ABRE) likely to bind the transcription factor ABI5 linking expression during this phase of seed development to ABA-dependent signaling.

Prx function in plant development is mostly unexplored. Plants with decreased levels or *At2-cys Prx* developed more slowly and had an altered photosynthetic phenotype during the first 4 to 6 weeks of development (Baier and Dietz, 1999a). Later on during development of the antisense plants, 2-Cys Prx accumulated to wild-type levels and the phenotype was wild-type-like. In the early developmental time window, where growth defects under specific conditions were apparent, up-regulation of ascorbate metabolism-related enzymes compensated for the lack of 2-Cys Prx (Baier *et al.*, 2000). Plants that lack PrxQ apparently develop like wild-type (Lamkemeyer *et al.*, 2006). Transcript analyses revealed compensatory gene regulation, for example up-regulation of  $\gamma$ -glutamyl cysteine synthase ( $\gamma$ -GCS) and glutathione reductase in these plants (Lamkemeyer *et al.*, 2006).

In a recent study Pena *et al.* (2006) analyzed silique and seed development as well as very early *Arabidopsis* seedling establishment after germination during the phase lasting from 1.5 to 5 days after radicle emergence. Transcript as well as protein levels of Prx with a role in photosynthesis roughly correlate with chlorophyll during silique and seed differentiation. Both decline during fruit and seed maturation and during the transition to the quiescent state (Pena, Dietz, Baier, unpublished). The data suggest a transition in antioxidant defence during early seedling development. Prx expression is high from the beginning of seedling growth indicating a significant role of an ascorbate-independent water/water cycle. In a converse manner ascorbate peroxidase only slowly increases during that phase of early development and reaches a maximum 2.5 days after radicle emergence. This suggests that the contribution of the ascorbate-dependent water/water cycle becomes important after depletion of the lipid reserves (Pena *et al.* 2006). The non-photosynthetic type II Prx, particularly the PrxII F showed little variation during these phases of plant development.

The type II Prx of *Arabidopsis thaliana* appear to be promising candidates in relation to a direct role in plant development. The peculiar and distinct expression pattern of the cytosolic type II Prx in *Arabidopsis* with very high transcript levels in buds, flowers and siliques is suggestive of a role in regular metabolism and possibly development of these tissues (Bréhélin *et al.*, 2003). *In situ* analysis of promoter activity using a  $\beta$ -glucuronidase reporter gene construct showed expression of *AtpixII C* in flower buds, *AtpixII D* in mature and germinating pollen, pollen tubes and fertilized ovules, and of *AtpixII E* in stamen of young flowers, the embryo sac, the albumen of older seeds from green to yellow siliques (Bréhélin *et al.*, 2003). The results from promoter reporter constructs (*AtpixII B*):GUS were not consistently reproducible. The tissue specific pattern of protein amounts, as visualized in Western blot analyses, reflected the transcript levels (Bréhélin *et al.*, 2003). The expression of *AtpixII C* and *D* is reminiscent of the *trx* regulation

in context of self-incompatibility and led the authors to suggest a developmental role for these two Prx isoforms. The high expression level of *AtprxII E* in anther tapetum may indicate a role of this particular plastid type II Prx in elaioplast lipid metabolism.

### 7. PLANT PEROXIREDOXINS IN SIGNALING AND OUTLOOK

Increasing experimental evidence indicates a role of peroxiredoxins in cell signaling (outlined in Fig. 4). Several mechanisms can be envisaged as to how peroxiredoxins initiate and modulate signaling in plant cells, i.e. through (i) modulation of hydrogen peroxide levels, (ii) alteration of lipid hydroperoxide concentrations, (iii) interference with peroxynitrite, (iv) drainage of electrons from electron donors, thereby affecting redox state of other targets, (v) adjustment of the redox state of interacting

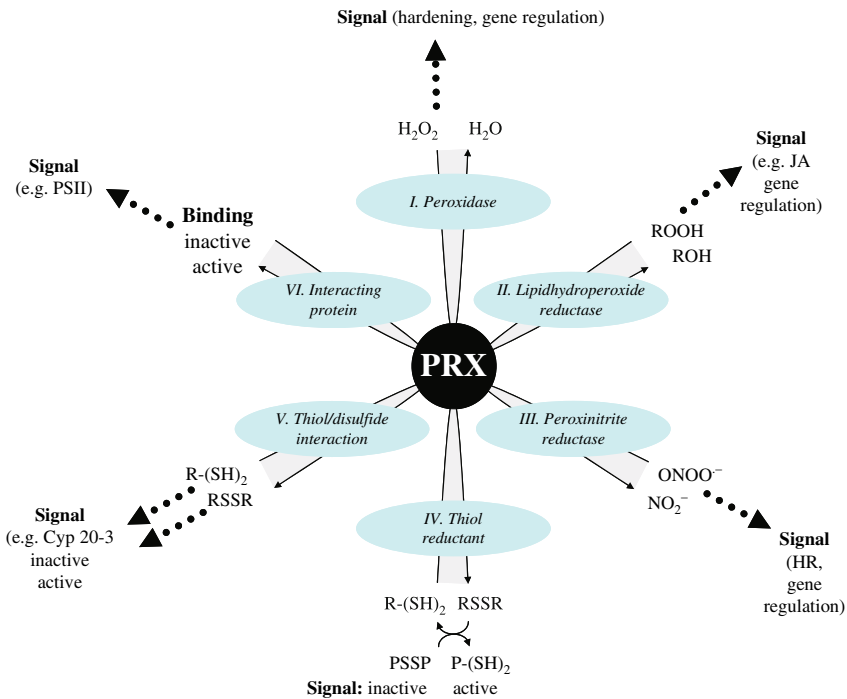

Figure 4. Possible functions of peroxiredoxins in cell signaling; (i) modulation of hydrogen peroxide levels, (ii) alteration of lipid hydroperoxide concentrations, (iii) interference with peroxynitrite, (iv) drainage of electrons from electron donor R-(SH)<sub>2</sub>, thereby affecting redox state of another target P-(SH)<sub>2</sub>, (v) adjustment of the redox state of interacting thiol proteins, e.g. Cyp20-3, (vi) redox-dependent conformation changes with consequences for binding to non-thiol proteins, e.g. photosystem II. See text for details. HR: hypersensitive response; JA: jasmonic acids; PSII: photosystem II; R-(SH)<sub>2</sub>: dithiol donor such as thioredoxin; RSSR: oxidized donor; P-(SH)<sub>2</sub>, PSSP: alternative acceptor of dithiol donor

thiol proteins, (vi) redox-dependent conformation changes with consequences to binding to non-thiol proteins.

- (i) Due to their activity as peroxidases, peroxiredoxins modulate the concentrations of hydroperoxides. Hydrogen peroxide is a major ROS signal during adaptation and development (Neill *et al.*, 2002). Resting concentrations are low. As a consequence of metabolic redox imbalances and upon invasion by pathogens, hydrogen peroxide concentrations rise and trigger changes in nuclear gene expression (Gadjev *et al.*, 2006). Peroxiredoxins have a low catalytic efficiency but high peroxiredoxin concentrations in the plastids may compensate for the low catalytic activity enabling the adjustment of a low resting concentration (Dietz *et al.*, 2006a). The floodgate theory advanced by Wood *et al.* (2003) probably also applies to plant 2-Cys Prx. In a number of studies an increased level of over-oxidized 2-Cys Prx has been reported (Broin and Rey, 2003; Rey *et al.*, 2006; Pérez-Ruiz *et al.*, 2006). Under such conditions the 2-Cys Prx cannot contribute to maintaining the low resting concentration of  $H_2O_2$  needed for normal cell metabolism and the  $H_2O_2$  signal can more easily spread, for instance as a chloroplast-to-cytosol signal to trigger the appropriate (genetic) responses.
- (ii) Peroxiredoxins have the potential to modulate lipid hydroperoxide levels and may affect concentrations of lipid peroxide-derived oxylipins (Baier and Dietz 1999b) that in turn also modulate plant responses at the level of gene expression (Schillmiller and Howe, 2004).
- (iii) Prxs detoxify peroxynitrite that mediates nitration of proteins. Peroxynitrite derives from NO reacting with the superoxide anion radical. Protein nitration has both a damaging potential and a regulatory capacity. Thus, the efficiency to decompose peroxynitrite by the peroxiredoxins likely is a regulator of nitration. In animal cell systems peroxynitrite triggers cell death (Virag *et al.*, 2003). In plants, peroxynitrite does not directly cause cell death, rather the ratio of hydrogen peroxide and peroxynitrite determines the hypersensitive response in pathogen defence (Delledonne *et al.*, 2001). The chloroplast PrxII E can be nitrosylated, and thereby its peroxidase activity is lost. A regulatory scenario presuming highly elevated NO levels suggests that the hydrogen peroxide concentration increases upon inactivation of PrxII E. This may ease induction of the cell death programme as part of the hypersensitive response (M. Romero-Puertas, M. Laxa, KJ Dietz, M. Delledonne, unpublished).
- (iv) Oxidized peroxiredoxins drain electrons from electron thiol donors and indirectly affect the redox state and possibly activity of other targets that are regulated by redox interactions with these donors. In this context Prx may be considered as a kinetic peroxide sensor transmitting the information of elevated peroxide levels to other thiol proteins (Dietz, 2003a).
- (v) In a direct interaction Prxs adjust the redox state of interacting thiol proteins that may mediate responses to non-thiol proteins. Cyclophilins with conserved Cys residues are the best studied example. The activity of the chloroplast cyclophilin *AtCyp20-3* depends on its redox state (Motohashi *et al.*, 2003). In

addition Cyp20-3 donates electrons to 2-Cys Prx. The Cys residues essential for the interaction with 2-Cys Prx and for peptidylprolyl-*cis/trans* isomerase (PPIase) have been identified (Laxa *et al.*, 2006). This allows us to suggest that a regulatory circuit where the relative rates of peroxide detoxification via Prx and thioredoxin-dependent re-reduction of Cyp20-3 regulates the non-thiol targets of this PPIase. The targets of Cyp20-3 and the physiological context will have to be characterized to validate this hypothesis and to judge its significance.

- (vi) Peroxiredoxins function as chaperones and some of them also undergo redox-dependent conformation changes with consequences for binding to non-thiol proteins and other cell structures. This has been outlined above for the chloroplast 2-Cys Prx that binds reversibly to thylakoids, possibly to photosystem II similar to Prx Q (Lamkemeyer *et al.*, 2006). Prx attachment appears to modify photosynthetic properties (Dietz *et al.*, 2006b). Thus, the redox-dependent conformational state of Prx will affect cell properties and functions as transmitter in cell signaling. Recently, Barranco-Medina *et al.* (2006) observed, by analysis of crystal structure, that the mitochondrial PrxII F of pea can assemble to regular hexamers. The consequences of this type of novel oligomerisation will have to be worked out in relation to conformational dynamics and novel Prx/protein interactions with possibly regulatory functions.

None of the above mentioned mechanisms has been explored in sufficient detail. Indirect evidence already indicates the involvement of Prx and existence of some of these signaling pathways, respectively. Modified activity of chloroplast 2-Cys Prx (Baier *et al.*, 2000), chloroplast Prx Q (Lamkemeyer *et al.*, 2006) and mitochondrial PrxII F (Finkemeier *et al.*, 2005) alters nuclear gene expression. Apparently, the absence or presence of organellar Prx triggers signals and transduction pathways that, across organellar borders, regulate promoter activities. This is an important field open for future studies and needs to be explored in order to further understand Prx function in plants.

## ACKNOWLEDGEMENTS

Support for our own cited work by the Deutsche Forschungsgemeinschaft is gratefully acknowledged (Di 346/6; FOR 387, TP3).

## REFERENCES

- Asada, K., 2000, The water-water cycle as alternative photon and electron sinks. *Philos. Trans. R. Soc. Lond. B Biol. Sci.* **355**: 1419–1431.
- Asada, K., 2006, Production and scavenging of reactive oxygen species in chloroplasts and their functions. *Plant Physiol.* **141**: 391–396.
- Backhausen, J.E., Kitzmann, C., Horton, P., Scheibe, R., 2000, Electron acceptors in isolated intact spinach chloroplasts act hierarchically to prevent over-reduction and competition for electrons. *Photosynth. Res.* **64**: 1–13.

- Baier, M., Dietz, K.J., 1996, Primary structure and expression of plant homologues of animal and fungal thioredoxin-dependent peroxide reductases and bacterial alkyl hydroperoxide reductases. *Plant Mol. Biol.* **31**: 553–564.
- Baier, M., Dietz, K.-J., 1997, The plant 2-Cys peroxiredoxin BAS1 is a nuclear encoded chloroplast protein. Its expressional regulation, phylogenetic origin, and implications for its specific physiological function in plants. *Plant J.* **12**: 179–190.
- Baier, M., Dietz, K.-J., 1999a, Protective function of chloroplast 2-Cys peroxiredoxin in photosynthesis: Evidence from transgenic *Arabidopsis thaliana*. *Plant Physiol.* **119**: 1407–1414.
- Baier, M., Dietz, K.J., 1999b, Alkyl hydroperoxide reductases: the way out of the oxidative breakdown of lipids in chloroplasts. *Trends Plant Sci.* **4**: 166–168.
- Baier, M., Dietz, K.-J., 2005, Chloroplasts as source and target of cellular redox regulation: a discussion on chloroplast redox signals in the context of plant physiology. *J. Exp. Bot.* **56**: 1449–1462.
- Baier, M., Noctor, G., Foyer, C.H., Dietz, K.-J., 2000, Antisense suppression of 2-Cys peroxiredoxin in *Arabidopsis thaliana* specifically enhances the activities and expression of enzymes associated with ascorbate metabolism, but not glutathione metabolism. *Plant Physiol.* **124**: 823–832.
- Baier, M., Stroher, E., Dietz, K.-J., 2004, The acceptor availability at photosystem I and ABA control nuclear expression of 2-Cys peroxiredoxin-A in *Arabidopsis thaliana*. *Plant Cell Physiology* **45**: 997–1006.
- Bakalovic, N., Passardi, F., Ioannidis, V., Cosio, C., Penel, C., Falquet, L., Dunand, C., 2000, PeroxiBase: a class III plant peroxidase database. *Phytochemistry* **67**(6): 534–539.
- Balmer, Y., Koller, A., del Val, G., Manieri, W., Schürmann, P., Buchanan, B.B., 2003, Proteomics gives insight into the regulatory function of chloroplast thioredoxins. *Proc. Natl. Acad. Sci. U S A.* **100**: 370–375.
- Barranco-Medina, S., Lopez-Jaramillo, F.J., Bernier-Villamor, L., Sevilla, F., Lazaro, J.J., 2006, Cloning, overexpression, purification and preliminary crystallographic studies of a mitochondrial type II peroxiredoxin from *Pisum sativum*. *Acta Crystallograph. Sect. F Struct. Biol. Cryst. Commun.* **62**: 695–698.
- Biteau, B., Labarre, J., Toledano, M.B., 2003, ATP-dependent reduction of cysteine-sulphinic acid by *S-cerevisiae* sulphiredoxin. *Nature* **425**: 980–984.
- Bréhélin, C., Meyer, E.H., de Souris, J.P., Bonnard, G., Meyer, Y., 2003, Resemblance and dissemblance of *Arabidopsis* type II peroxiredoxins. Similar sequences for divergent gene expression, protein localization and activity. *Plant Physiology* **132**: 2045–2057.
- Broin, M., Cuiñé, S., Eymery, F., Rey, P., 2002, The plastidic 2-cysteine peroxiredoxin is a target for a thioredoxin involved in the protection of the photosynthetic apparatus against oxidative damage. *Plant Cell* **14**: 1417–1432.
- Broin, M., Rey, P., 2003, Potato plants lacking the CDSP 32 plastidic thioredoxin exhibit overoxidation of the BAS1 2-Cysteine peroxiredoxin and increased lipid peroxidation in thylakoid under photooxidative stress. *Plant Physiol.* **132**: 1335–1343.
- Bryk, R., Griffin, P., Nathan, C., 2000, Peroxynitrite reductase activity of bacterial peroxiredoxins. *Nature* **407**: 211–215.
- Buchanan, B.B., Balmer, Y., 2005, Redox regulation: a broadening horizon. *Annu. Rev. Plant Biol.* **56**: 187–220.
- Chang, T.S., Jeong, W., Woo, H.A., Lee, S.M., Park, S., Rhee, S.G., 2004, Characterization of mammalian sulfiredoxin and its reactivation of hyperoxidized peroxiredoxin through reduction of cysteine sulfinic acid in the active site to cysteine. *J. Biol. Chem.* **279**: 50994–51001.
- Choi, H.J., 1998, Crystal structure of a novel human peroxidase enzyme at 2.0Å resolution. *Nature Struct. Biol.* **5**: 400–406.
- Chew, O., Whelan, J., Millar, A.H., 2003, Molecular definition of the ascorbate-glutathione cycle in *Arabidopsis* mitochondria reveals dual targeting of antioxidant defenses in plants. *J. Biol. Chem.* **278**: 46869–46877.
- Collin, V., Issakidis-Bourguet, E., Marchand, C., Hirasawa, M., Lancelin, J.M., Knaff, D.B., Miginiac-Maslow, M., 2003, The *Arabidopsis* plastidial thioredoxins - New functions and new insights into specificity. *J. Biol. Chem.* **278**: 23747–23752.

- Collin, V., Lamkemeyer, P., Miginiac-Maslow, M., Hirasawa, M., Knaff, D.B., Dietz, K.-J., Issakidis-Bourguet, E., 2004, Characterization of plastidial thioredoxins from *Arabidopsis* belonging to the new *y*-type. *Plant Physiology* **136**: 4088–4095.
- Delledonne, M., Zeier, J., Marocco, A., Lamb, C., 2001, Signal interactions between nitric oxide and reactive oxygen intermediates in the plant hypersensitive disease resistance response. *Proc. Natl. Acad. Sci. USA* **98**: 13454–13459.
- Dietz, K.-J., 2003a, Redox control, redox signaling, and redox homeostasis in plant cells. *Int. Rev. Cytol.* **228**: 141–193.
- Dietz, K.-J., 2003b Plant peroxiredoxins. *Annu. Rev. Plant Biol.* **54**: 93–107.
- Dietz, K.-J., Jacob, S., Oelze, M.-L., Laxa, M., de Miranda, S.M.N., Baier, M., Finkemeier, I., 2006a, The function of peroxiredoxins in plant organelle redox metabolism. *J. Exp. Bot.* **57**: 1697–1709.
- Dietz, K.J., Horling, F., König, J., Baier, M., 2002, The function of the chloroplast 2-cysteine peroxiredoxin in peroxide detoxification and its regulation. *J. Exp. Bot.* **53**: 1321–1329.
- Dietz, K.-J., Krämer, U., Baier, M., 1999, Free radicals and reactive oxygen species as mediators of heavy metal toxicity. In: Heavy metal stress in plants: From molecules to ecosystems. M.N.V. Prasad, J. Hagemeyer, eds., Springer Verlag, pp. 73–97.
- Dietz, K.-J., Lamkemeyer, P., Li, W.X., Kahmann, U., Finkemeier, I., Baier, M., 2005, Towards an understanding of peroxiredoxin function in photosynthesis. Proceedings of the 13th International Congress of Photosynthesis in Montréal, Canada, van der Est A, Bruce D, eds., Section 10 (ISBN 1-891276-395), 465–468.
- Dietz, K.-J., Stork, T., Finkemeier, I., Lamkemeyer, P., Li, W.X., El-Tayeb, M.A., Michel, K.P., Pistorius, E., Baier, M., 2006b, The role of peroxiredoxins in oxygenic photosynthesis of cyanobacteria and higher plants: peroxide detoxification or redox sensing? In: Photoprotection, photoinhibition, gene regulation, and environment. Demmig-Adams B, Adams W, Mattoo A, eds. Kluwer Acad Press, 303–319.
- Finkemeier, I., Goodman, M., Lamkemeyer, P., Kandlbinder, A., Sweetlove, L.J., Dietz, K.-J., 2005, The mitochondrial type II peroxiredoxin F is essential for redox homeostasis and root growth of *Arabidopsis thaliana* under stress. *J. Biol. Chem.* **280**: 12168–12180.
- Gadjev, I., Vanderauwera, S., Gechev, T.S., Laloi, C., Minkov, I.N., Shulaev, V., Apel, K., Inze, D., Mittler, R., Van Breusegem, F., 2006, Transcriptomic footprints disclose specificity of reactive oxygen species signaling in *Arabidopsis*. *Plant Physiol.* **141**: 436–445.
- Genot, G., Wintz, H., Houlné, G., Jamet, E., 2001, Molecular characterization of a bean chloroplastic 2-Cys peroxiredoxin. *Plant Physiol. Biochem.* **39**: 449–459.
- Haslekas, C., Grini, P.E., Nordgard, S.H., Thorstensen, T., Viken, M.K., Nygaard, V., Aalen, R.B., 2003, ABI3 mediates expression of the peroxiredoxin antioxidant AtPER1 gene and induction by oxidative stress. *Plant Mol. Biol.* **53**: 313–326.
- Haslekas, C., Stacy, R.A., Nygaard, V., Culiñez-Macia, F.A., Aalen, R.B., 1998, The expression of a peroxiredoxin antioxidant gene, AtPer1, in *Arabidopsis thaliana* is seed-specific and related to dormancy. *Plant Mol. Biol.* **36**(6): 833–845.
- Helman, Y., Tchernov, D., Reinhold, L., Shibata, M., Ogawa, T., Kaplan, A., 2003, Genes encoding A-type flavoprotein are essential for photoreduction of O<sub>2</sub> in cyanobacteria. *Current Biology* **13**: 230–235.
- Himmelbach, A., Yang, Y., Grill, E., 2003, Relay and control of abscisic acid signaling. *Curr. Opin. Plant Biol.* **6**:470–479.
- Hofmann, B., Hecht, H.J., Flohe, L., 2002, Peroxiredoxins. *Biol. Chem.* **383**(3–4): 347–364.
- Holtgreffe, S., Bader, K.P., Horton, P., Scheibe, R., von Schaewen, A., Backhausen, J.E., 2003, Decreased content of leaf ferredoxin changes electron distribution and limits photosynthesis in transgenic potato plants. *Plant Physiol.* **133**:1768–1778.
- Horling, F., Baier, M., Dietz, K.-J., 2001, Redox-regulation of the expression of the peroxide-detoxifying chloroplast 2-cys peroxiredoxin in the liverwort *Riccia fluitans*. *Planta* **214**: 304–313.
- Horling, F., König, J., Dietz K.J., 2006, Type II peroxiredoxin C, a member of the peroxiredoxin family of *Arabidopsis thaliana*: its expression and activity in comparison with other peroxiredoxins. *Plant Physiol. Biochem.* **40**: 491–499.



- Horling, F., Lamkemeyer, P., König, J., Finkemeier, I., Kandlbinder A., Baier, M., Dietz, K.-J., 2003, Divergent light-, ascorbate-, and oxidative stress-dependent regulation of expression of the peroxiredoxin gene family in Arabidopsis. *Plant Physiol.* **131**: 317–325.
- Jang, H.H., Chi YH, Park, S.K., Lee, S.S., Lee, J.R., Park, J.H., Moon, J.C., Young Mee Lee, Y.M., Kim, S.Y., Lee, K.O., Lee S.Y., 2006, Structural and functional regulation of eukaryotic 2-Cys peroxiredoxins including the plant ones in cellular defense-signaling mechanisms against oxidative stress. *Physiol. Plant.* **126**: 549–559.
- Jang, J.-C., Sheen, J., 1994, Sugar signaling in higher plants. *Plant Cell* **6**: 1665–1679.
- Kandlbinder, A., Finkemeier, I., Wormuth, D., Hanitzsch, M., Dietz, K.-J., 2004, The antioxidant status of photosynthesizing leaves under nutrient deficiency: redox regulation, gene expression and antioxidant activity in *Arabidopsis thaliana*. *Physiol. Plant.* **120**: 63–73.
- Kiba, A., Nishihara, M., Tsukatani, N., Nakatsuka, T., Kato, Y., Yamamura, S., 2005, A peroxiredoxin Q homolog from gentians is involved in both resistance against fungal disease and oxidative stress. *Plant Cell Physiol.* **46**: 1007–1015.
- Kliebenstein, D.J., Monde, R.A., Last, R.L., 1998, Superoxide dismutase in Arabidopsis: an eclectic enzyme family with disparate regulation and protein localization. *Plant Physiol.* **118**: 637–650.
- Klughhammer, B., Baier, M., Dietz, K.J., 1998, Inactivation by gene disruption of 2-cysteine-peroxiredoxin in *Synechocystis* sp. PCC 6803 leads to increased stress sensitivity. *Physiol. Plant.* **104**: 699–706.
- Kong, W., Shiota, S., Shi, Y., Nakayama, H., Nakayama, K., 2000, A novel peroxiredoxin of the plant *Sedum lineare* is a homologue of *Escherichia coli* bacterioferritin co-migratory protein (Bcp). *Biochem. J.* **351**: 107–114.
- König, J., Baier, M., Horling, F., Kahmann, U., Harris, G., Schürmann, P., Dietz, K.-J., 2002, The plant-specific function of 2-Cys peroxiredoxin-mediated detoxification of peroxides in the redox-hierarchy of photosynthetic electron flux. *Proc. Natl. Acad. Sci. USA* **99**: 5738–5743.
- König, J., Lotte, K., Plessow, R., Brockhinke, A., Maier, M., Dietz, K.-J., 2003, Reaction mechanism of plant 2-Cys peroxiredoxin: Role of the C terminus and the quaternary structure. *J. Biol. Chem.* **278**: 24409–24420.
- Lamkemeyer, P., Laxa, M., Collin, V., Li, W., Finkemeier, I., Schottler, M.A., Holtkamp, V., Tognetti, V.B., Issakidis-Bourguet, E., Kandlbinder, A., Weis, E., Miginiac-Maslow, M. Dietz, K.J. 2006, Peroxiredoxin Q of Arabidopsis thaliana is attached to the thylakoids and functions in context of photosynthesis. *Plant J.* **45**: 968–981.
- Laxa, M., König, J., Dietz, K.-J., Kandlbinder, A., 2006, Role of the cysteinyl residues in Arabidopsis thaliana cyclophilin CYP20-3 in rotamase and redox-related functions. *Biochem. J.*, in press.
- Lee, S.P., Hwang, Y.S., Kim, Y.J., Kwon, K.S., Kim, H.J., Kim, K., Chae, H.Z., 2001, Cyclophilin A binds to peroxiredoxins and activates its peroxidase activity. *J. Biol. Chem.* **276**(32): 29826–29832.
- Lindermayr, C., Saalbach, G., Durne, J., 2005, Proteomic identification of S-nitrosylated proteins in Arabidopsis. *Plant Physiol.* **137**: 921–930.
- Liu, X.P., Liu, X.Y., Zhang, J., Xia, Z.L., Liu, X., Qin, H.J., Wang, D.W., 2006, Molecular and functional characterization of sulfiredoxin homologs from higher plants. *Cell Res.* **16**: 287–296.
- McClung, C.R., 1997, Regulation of catalases in Arabidopsis. *Free Radic. Biol. Med.* **23**(3): 489–496.
- Meissner, U., Schroder, E., Scheffler, D., Martin, A.G., Harris, J.R., 2006, Formation, TEM study and 3D reconstruction of the human erythrocyte peroxiredoxin-2 dodecahedral higher-order assembly. *Micron* **38**: 29–39.
- Meyer, Y., Reichheld, J.P., Vignol, F., 2005, Thioredoxins in Arabidopsis and other plants. *Photosynth. Res.* **86**: 419–433.
- Miyake, C., Asada, K., 1992, Thylakoid-bound ascorbate peroxidase in spinach chloroplasts and photoreduction of its primary oxidation product monodehydroascorbate radicals in thylakoids. *Plant Cell Physiology* **33**: 541–553.
- Mittler, R., Vanderauwera, S., Gollery, M., Van Breusegem, F., 2004, Reactive oxygen gene network of plants. *Trends Plant Sci.* **9**: 490–498.
- Motohashi, K., Kondoh, A., Stumpp, M.T., Hisabori, T., 2001, Comprehensive survey of proteins targeted by chloroplast thioredoxin. *Proc. Natl. Acad. Sci. USA* **98**: 11224–11229.

- Motohashi, K., Koyama, F., Nakanishi, Y., Ueoka-Nakanishi, H., Hisabori, T., 2003, Chloroplast cyclophilin is a target protein of thioredoxin. Thiol modulation of the peptidyl-prolyl cis-trans isomerase activity. *J. Biol. Chem.* **278**: 31848–31852.
- Mutsuda, M., Ishikawa, T., Takeda, T., Shigeoka, S., 1996, The catalase-peroxidase of *Synechococcus* PCC 7942: purification, nucleotide sequence analysis and expression in *Escherichia coli*. *Biochem. J.* **316**: 251–257.
- Mylona, P.V., Polidoros, A.N., Scandalios, J.G., 1998, Modulation of antioxidant responses by arsenic in maize. *Free Radic. Biol. Med.* **25**: 576–585.
- Neill, S., Desikan, R., Hancock, J., 2002, Hydrogen peroxide signaling. *Curr. Opin. Plant Biol.* **5**: 388–395.
- Nishiyama, Y., Yamamoto, H., Allakhverdiev, S.I., Inaba, M., Yokota, A., Murata, N., 2001, Oxidative stress inhibits the repair of photodamage to the photosynthetic machinery. *EMBO J.* **20**:5587–5594.
- Noctor, G., Veljovic-Jovanovic, S., Foyer, C.H., 2000, Peroxide processing in photosynthesis: antioxidant coupling and redox signaling. *Philos. Trans. R. Soc. Lond. B Biol. Sci.* **355**: 1465–1475.
- Panchuk, I.I., Zentgraf, U., Volkov, R.A., 2005, Expression of the Apx gene family during leaf senescence of *Arabidopsis thaliana*. *Planta* **222**: 926–932.
- Pastori, G.M., Kiddle, G., Antoniw, J., Bernard, S., Veljovic-Jovanovic, S., Verrier, P.J., Noctor, G., Foyer, C.H., 2003, Leaf vitamin C contents modulate plant defense transcripts and regulate genes that control development through hormone signaling. *Plant Cell.* **15**: 939–951.
- Pena, A., Dietz, K.-J., Baier, M., 2006, Regulation of peroxiredoxin expression versus expression of Halliwell-Asada-Cycle enzymes during early seedling development of *Arabidopsis thaliana*. *Photosynthesis Res.*, in press
- Pérez-Ruiz, J.M., Spinola, M.C., Kirchsteiger, K., Moreno, J., Sahrawy, M., Cejudo, F.J., 2006, NTRC is a high-efficiency redox system for chloroplast protection against oxidative damage. *Plant Cell* (in press)
- Pfannschmidt, T., Schutze, K., Fey, V., Sherameti, I., Oelmüller, R., 2003, Chloroplast redox control of nuclear gene expression—a new class of plastid signals in interorganellar communication. *Antioxid. Redox Signal.* **5**: 95–101.
- Pruvot, G., Cuine, S., Peltier, G., Rey, P., 1996, Characterization of a novel drought-induced 34-kDa protein located in the thylakoids of *Solanum tuberosum* L. plants. *Planta* **198**: 471–479.
- Requejo, R., Tena, M., 2005, Proteome analysis of maize roots reveals that oxidative stress is a main contributing factor to plant arsenic toxicity. *Phytochemistry* **66**: 1519–1528.
- Rey, P., Bécuwe, N., Barrault, M.B., Rumeau, D., Havaux M., Biteau, B., Toledano, M.B., 2006, The *Arabidopsis thaliana* sulfiredoxin is a plastidic cysteine-sulfenic acid reductase involved in photooxidative stress response. *Plant Journal*, in press.
- Rhee, S.G., Chae, H.Z., Kim, K., 2005, Peroxiredoxins: a historical overview and speculative preview of novel mechanisms and emerging concepts in cell signaling. *Free Radic. Biol. Med.* **38**: 1543–1552.
- Rodriguez Milla, M.A., Maurer, A., Rodriguez Huete, A., Gustafson, J.P., 2003, *Plant J.* **36**: 602–615.
- Romano, P.G.N., Horton, P., Gray, J.E., 2004, The *Arabidopsis* cyclophilin gene family. *Plant Physiology* **134**: 1268–1282.
- Rook, F., Bevan, M.W., 2003, Genetic approaches to understanding sugar-response pathways. *J. Exp. Bot.* **54**: 495–501.
- Rouhier, N., Gelhaye, E., Corbier, C., Jacquot, J.P., 2004a, Active site mutagenesis and phospholipid hydroperoxide reductase activity of poplar type II peroxiredoxin. *Physiologia Plantarum* **120**: 57–62.
- Rouhier, N., Gelhaye, E., Gualberto, J.M., Jordy, M.N., De Fay, E., Hirasawa, M., Duplessis, S., Lemaire, S.D., Frey, P., Martin, F., Manieri, W., Knaff, D.B., Jacquot, J.P., 2004b, Poplar peroxiredoxin Q. A thioredoxin-linked chloroplast antioxidant functional in pathogen defense. *Plant Physiol.* **134**: 1027–1036.
- Rouhier, N., Gelhaya, E., Jacquot, J.P., 2002, Glutaredoxin-dependent peroxiredoxin from poplar: protein-protein interaction and catalytic mechanism. *J. Biol. Chem.* **277**: 13609–13614.
- Rouhier, N., Gelhaye, E., Sautiere, P.E., Brun, A., Laurent, P., Tagu, D., Gerard, J., de Fay, E., Meyer, Y., Jacquot, J.P., 2001, Isolation and characterization of a new peroxiredoxin from poplar sieve tubes that uses either glutaredoxin or thioredoxin as a proton donor. *Plant Physiol.* **127**: 1299–1309.

- Rouhier, N., Jacquot, J.P., 2005a, The plant multigenic family of thiol peroxidases. *Free Radic. Biol. Med.* **38**: 1413–1421.
- Rouhier, N., Villarejo, A., Srivastava, M., Gelhaye, E., Keech, O., Droux, M., Finkemeier, I., Samuelsson, G., Dietz, K.-J., Jacquot, J.P., Wingsle, G., 2005b, Identification of plant glutaredoxin targets. *Antioxid Redox Signal* **7**: 919–929.
- Rouhier, N., 2006, The mitochondrial typeII peroxiredoxin from poplar. *Physiol Plant* in press.
- Sakamoto, A., Tsukamoto, S., Yamamoto, H., Ueda-Hashimoto, M., Takahashi, M., Suzuki, H., Morikawa, H., 2001, Functional complementation in yeast reveals a protective role of chloroplast 2-Cys peroxiredoxin against reactive nitrogen species. *Plant Journal* **33**: 841–851.
- Schafer, F.Q., Buettner, G.R., 2001, Redox environment of the cell as viewed through the redox state of the glutathione disulfide/glutathione couple. *Free Radic. Biol. Med.* **30**: 1191–1212.
- Schillmiller, A.L., Howe, G.A. 2005, Systemic signaling in the wound response. *Curr Opin Plant Biol.* **8**(4): 369–377.
- Schürmann, P., Jacquot, J.P., 2000, Plant thioredoxin systems revisited. *Annu. Rev. Plant Physiol Plant Mol. Biol.* **51**: 371–400.
- Serrato, A.J., Perez-Ruiz, J.M., Spinola, M.C., Cejudo, F.J., 2004, A novel NADPH thioredoxin reductase, localized in the chloroplast, which deficiency causes hypersensitivity to abiotic stress in *Arabidopsis thaliana*. *J. Biol. Chem.* **279**: 43821–43827.
- Smirnoff, N., 2000, Ascorbate biosynthesis and function in photoprotection. *Philos. Trans. R. Soc. Lond. B Biol. Sci.* **355**: 1455–1464.
- Stacy, R.A., Munthe, E., Steinum, T., Sharma, B., Aalen, R.B., 1996, A peroxiredoxin antioxidant is encoded by a dormancy-related gene, Per1, expressed during late development in the aleurone and embryo of barley grains. *Plant Mol. Biol.* **31**: 1205–1216.
- Stork, T., Michel, K.P., Pistorius, E.K., Dietz, K.J., 2005, Bioinformatic analysis of the genomes of the cyanobacteria *Synechocystis* sp. PCC 6803 and *Synechococcus elongatus* PCC 7942 for the presence of peroxiredoxins and their transcript regulation under stress. *J. Exp Bot* **56**: 3193–3206.
- Ströher, E., Dietz, K.-J., 2006, Concepts and approaches towards understanding the redox proteome. *Plant Biology* **8**: 407–418.
- Subramanian, B., Bansal, V.K., Kav, N.N.V., 2005, Proteome-level investigation of *Brassica carinata*-derived resistance to *Leptosphaeria maculans*. *J. Agr.Food Chem.* **53**: 313–324.
- Virag, L., Szabo, E., Gergely, P., Szabo, C., 2003, Peroxynitrite-induced cytotoxicity: mechanism and opportunities for intervention. *Toxicol. Lett.* **140–141**:113–124.
- Woo, H.A., Jeong, W.J., Chang, T.S., Park, K.J., Park, S.J., Yang, J.S., Rhee, S.G., 2005, Reduction of cysteine sulfinic acid by sulfiredoxin is specific to 2-Cys peroxiredoxins. *J. Biol. Chem.* **280**: 3125–3128.
- Wood, Z.A., Schröder, E., Harris, J.R., Poole, L.B., 2003, Structure, mechanism and regulation of peroxiredoxins. *Trends Biochem. Sci.* **28**: 32–40.
- Yamamoto, H., Miyake, C., Dietz, K.J., Tomizawa, K.I., Murata, N., Yokota, A., 1999, Thioredoxin peroxidase in the cyanobacterium *Synechocystis* sp. PCC 6803. *FEBS Lett.* **447**: 269–273.

## CHAPTER 14

# MITOCHONDRIAL PEROXIREDOXINS

## *Structure and Function*

ZHENBO CAO,<sup>1</sup> J. GORDON LINDSAY<sup>1</sup> AND NEIL W. ISAACS<sup>2</sup>

<sup>1</sup>*Division of Biochemistry and Molecular Biology, Davidson Building, Institute of Biomedical and Life Sciences, University of Glasgow, Glasgow G12 8QQ, UK*

<sup>2</sup>*WestCHEM, Department of Chemistry, University of Glasgow, Glasgow G12 8QQ, UK*

**Abstract:** Mitochondria are the major intracellular sites of oxygen consumption producing reactive oxygen species (ROS) as toxic by-products of oxidative phosphorylation, primarily via electron leakage from the respiratory chain. The resultant types of chemical damage to lipids, DNA and proteins are described as well as the broader implications for the involvement of ROS in disease onset and progression. The relative contributions of mitochondrial, enzyme-linked, antioxidant defence systems to tissue protection are also reviewed as is the emerging importance of the peroxiredoxin family in general to H<sub>2</sub>O<sub>2</sub>-mediated signalling

The constituent enzymes of the mitochondrial PrxIII pathway are discussed in detail including the roles of PrxIII and PrxV in their capacities as typical 2-cys and atypical 2-cys thioredoxin-dependent hydroperoxide reductases, respectively. The structures and catalytic mechanisms of PrxIII and V are examined and some key properties of the reconstituted mitochondrial PrxIII pathway are highlighted with specific reference to the susceptibility of peroxiredoxins to inactivation at elevated H<sub>2</sub>O<sub>2</sub> levels and their potential for participation in H<sub>2</sub>O<sub>2</sub>-mediated signalling responses. It is concluded that mitochondrial Prxs form a vital link in an integrated cellular antioxidant defence network that minimises ROS-mediated damage and ensures that cells mount appropriate responses to increased levels of oxidative stress via the upregulation of key cell signalling pathways

**Keywords:** Mitochondria, Reactive oxygen species, Enzyme-linked, Antioxidant defence systems, PrxIII and PrxV, Structure-function relationships, Reconstitution of PrxIII pathway, Prx overoxidation, Involvement in H<sub>2</sub>O<sub>2</sub>-mediated signalling

## 1. INTRODUCTION

### 1.1. Mitochondria

Mitochondria are universally recognised as the powerhouses of living cells where the bulk of the energy required for life is obtained from the major fuel molecules in the central pathways of carbohydrate, fat and amino acid metabolism located in

the mitochondrial matrix. Initially, energy is captured in the form of the reduced coenzymes, NADH and FADH<sub>2</sub> that possess high electron transfer potential and which are then re-oxidised via a series of transmembrane proton-translocating complexes in the electron transport chain of the inner membrane with O<sub>2</sub> as the ultimate electron acceptor. The resulting electrochemical (proton) gradient generated across the mitochondrial inner membrane is converted into ATP in the mitochondrial matrix compartment by a vectorial, membrane-spanning ATP synthase complex.

In the past 15 years, there has been a rapid development of interest in the broader roles of mitochondria in the context of the cell including the importance of mitochondrial-cytoplasmic interactions, protein trafficking to the organelle and mitochondrial involvement in the regulation of cellular integrity and lifespan in general. In particular, the role of mitochondria in the induction of programmed cell death (apoptosis) and necrosis have been the subject of intense investigation (Green and Reed, 1998; Kroemer and Reed, 2000; Newmeyer and Ferguson-Miller, 2003). This has led to the idea that a decline in mitochondrial function, in particular as a result of oxidative stress, can contribute significantly to the onset of a wide range of major disease states such as diabetes, cancer, neurodegenerative disorders and the ageing process itself. In this chapter, we shall focus on the emerging importance of mitochondrial peroxiredoxins PrxIII and PrxV in antioxidant defence and H<sub>2</sub>O<sub>2</sub>-mediated signalling and their broader *in vivo* role in maintaining mitochondrial structural and functional integrity and cell viability.

## 1.2. Oxidative Stress

Oxidative stress is a general term that is applied to the occurrence of severe damage to cellular macromolecules resulting from an imbalance in the production and removal of redox-active species. As the main intracellular sites of oxygen consumption, mitochondria produce reactive oxygen species (ROS) as toxic by-products of respiration (Loschen *et al.*, 1971; Loschen *et al.*, 1974). The three major ROS, namely superoxide anions (O<sub>2</sub><sup>•-</sup>), hydrogen peroxide (H<sub>2</sub>O<sub>2</sub>) and hydroxyl radicals (•OH) are in effect partially reduced products of O<sub>2</sub> generated by leakage of electrons from the electron transport chain at specific points, particularly via the NADH-CoQ reductase (complex I) and CoQ-cytochrome c reductase (complex III) complexes as illustrated in Fig 1. Hydroxyl radicals are produced indirectly from H<sub>2</sub>O<sub>2</sub> via the Fenton reaction that occurs in the presence of iron or copper that are essential components of all four mitochondrial respiratory chain complexes. Recent evidence, however, it has also been demonstrated that the 2-oxoglutarate dehydrogenase (OGDC) multi-enzyme complex, a key regulatory component of the citric acid cycle, can be a significant source of superoxide anion and H<sub>2</sub>O<sub>2</sub> production (Starkov *et al.*, 2004; Tretter and Adam-Vizi, 2004), apparently via electron leakage from the flavin ring of its 3rd constituent enzyme, dihydrolipoamide dehydrogenase (E3). Interestingly, the E3 enzyme is common to a group of structurally and mechanistically related mitochondrial complexes including the pyruvate and

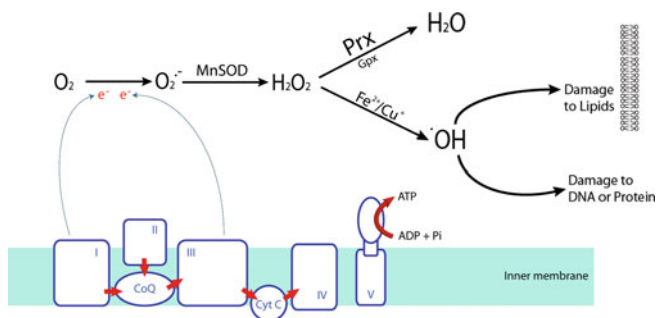

*Figure 1.* Simplified scheme illustrating ROS production by mitochondria and relevant antioxidant systems. O<sub>2</sub> is partially reduced to superoxide anions primarily by electron leakage from complexes I and III of the respiratory chain. Superoxide anions are reactive free radicals but can be converted to H<sub>2</sub>O<sub>2</sub> in the mitochondrial matrix by SOD2, MnSOD. Although H<sub>2</sub>O<sub>2</sub> is a mild oxidant, it can be converted to highly-damaging hydroxyl radicals via the Fenton reaction in the presence of Cu<sup>+</sup> or Fe<sup>2+</sup>. The removal of H<sub>2</sub>O<sub>2</sub> can be promoted by catalases, GPxs and Prxs (See Plate 19)

branched-chain 2-oxoacid dehydrogenase complexes so it is unclear at present why OGDC should be the main contributor to the release of ROS.

## 2. TYPES OF DAMAGE TO MACROMOLECULES CAUSED BY ROS AND RNS

### 2.1. Lipid Damage

Lipid peroxidation is the main consequence of lipid oxidation by ROS due to the high susceptibility of the double bonds within polyunsaturated fatty acids to oxidative damage. Arachidonic acid and docosahexaenoic acids, which are abundant in the brain, are particularly susceptible to lipid peroxidation. Consequences of lipid peroxidation include an increase in aldehyde formation, mainly 4-hydroxyalkenals which exhibit potent cytotoxic effects (Esterbauer *et al.*, 1991). Lipid hydroperoxide formation is also characteristic in the pathogenesis of several other diseases, particularly cardiovascular disease where it is involved in atherosclerotic plaque formation (Gorog *et al.*, 2002).

Lipid hydroperoxides can be converted to free radicals, such as the peroxy radical, in the presence of bivalent metal ions, which enhance the production of numerous reactive compounds. Interestingly lipid hydroperoxides have been demonstrated to induce directly the expression of associated heat-shock proteins crucial to the stress response (Calabrese *et al.*, 2002).

### 2.2. DNA Oxidative Damage

DNA bases and the deoxyribose backbone are targets of oxidative damage. ROS exert their destructive effects on nucleic acids by inducing mutations *via* processes

such as DNA-protein cross-links, purine oxidation and DNA strand breaks. It is proposed that the principal ROS threat to DNA is the hydroxyl radical (Henle and Linn, 1997; Aust and Eveleigh, 1999) and the protonated form of peroxyxynitrite (peroxyxynitrous acid). As the hydroxyl radical is extremely reactive, it is unlikely that it reaches the nucleus. It is more probable that hydrogen peroxide diffuses into the nucleus where it serves as a source for hydroxyl radical generation. Peroxyxynitrous acid on the other hand can diffuse freely across membranes and into the nucleus. The DNA lesion involving the formation of 8-oxo-deoxyguanosine (8-oxo-dG) has been the most intensively studied, as it is methodologically easy to detect. 8-oxo-dG is extremely mutagenic and has been reported to introduce spontaneous mutations in several genes (Shibutani *et al.*, 1991; Kasai *et al.*, 1987). Other mutagenic lesions resulting from DNA oxidation include 5-hydroxyuracil and 5-hydroxy-deoxycytidine (Marnett, 2000). DNA can also be damaged by products of lipid peroxidation, for example malondialdehyde, which forms a DNA adduct with a mutagenic potential comparable to that of 8-oxo-dG (Marnett, 1999).

If DNA modifications are left un-repaired, incorrect base pairing occurs and somatic mutations accumulate, a feature of several human pathologies including many types of cancer. Mitochondrial DNA is particularly susceptible to oxidative damage due to its close proximity to ROS production and the fact that it is unprotected by histones, unlike chromosomal DNA. The level of oxidatively damaged bases in mtDNA is 10–20-fold higher in comparison to nuclear DNA. Studies have underlined a connection between damage to mtDNA and apoptosis (Esteve *et al.*, 1999). Mitochondrial genome lesions, leading to a decline in respiratory function associated with an elevation in ROS and impaired activity of mitochondrial antioxidant enzymes, are widely implicated as major contributors to the ageing process, which has become a rapidly expanding, and profitable area of research in recent years (Wei and Lee, 2002). For example, Ishii and co-workers have reported that a mutation in the cytochrome b gene of the succinate dehydrogenase complex (Complex II) in *Caenorhabditis elegans* leads to increased oxidative stress with this organism displaying oxygen hypersensitivity and a shortened lifespan (Ishii *et al.*, 1998).

### 2.3. Protein Oxidative Damage

The oxidative modification of proteins is less well characterised than DNA and lipid damage. Destruction is attributed mainly to the hydroxyl radical, generated by the Fenton reaction, giving rise to various modifications including the oxidation of amino acid side-chains, formation of protein-protein cross-links and polypeptide backbone oxidation resulting in chain fragmentation (Stadtman and Berlett, 1991; Berlett and Stadtman, 1997). In general, the oxidative modification of proteins results in conformational changes, misfolding and consequently impaired function. A prime example is the distortion of metal binding sites and the modification of amino acid residues that are essential for enzyme regulation, for example, serine

residues that are the sites of phosphorylation. All amino acid side-chains are susceptible to oxidation; however, favoured targets are the sulphur-containing amino acid residues, cysteine and methionine, and the aromatic amino acids tryptophan and tyrosine. Cysteine and methionine residues are especially vulnerable targets for all ROS, even at reduced levels. Cysteine thiol groups become oxidised to disulphides, and methionine can be oxidised to methionine sulphoxide (MeSOX). These modifications are the main examples of reversible oxidations as they can be reconverted to their original states by disulphide reductases and MeSOX reductases, respectively.

Other common oxidative modifications include the conversion of histidine to asparagine, and proline residues to glutamic semialdehyde residues. All amino acids, especially lysine, can generate carbonyl derivatives as a consequence of oxidative damage. Carbonyl derivatives provide a means by which the oxidative damage to a protein can be assessed. Studies were carried out in *Saccharomyces cerevisiae* and *Escherichia coli* to elucidate which proteins were susceptible to oxidative damage when exposed to hydrogen peroxide and the superoxide anion, by measuring the carbonyl content of each enzyme. The major targets in yeast were primarily mitochondrial enzymes including the dihydrolipoamide acyltransferase (E2) components of the pyruvate dehydrogenase and 2-oxoglutarate dehydrogenase complexes, aconitase, and the molecular chaperone HSP-60 (Tamarit *et al.*, 1998; Cabiscol *et al.*, 2000) in addition to the cytosolic enzymes fatty acid synthase and glyceraldehyde-3-phosphate dehydrogenase. This is not surprising given the extremely high ROS concentrations in mitochondria, and further supports the role of impaired mitochondrial function in ageing and oxidative-stress related disorders (Cadenas and Davies, 2000).

#### 2.4. The Role of Oxidative Stress in Disease

Cells and tissues compromised by oxidative stress are characteristic features of several human diseases, particularly autoimmune diseases including diabetes mellitus and inflammatory conditions such as rheumatoid arthritis. Furthermore, several neurodegenerative pathologies including Alzheimer's disease (AD), Parkinson's disease (PD), Friedreich's ataxia, and Creutzfeldt-Jakob Syndrome, are associated with high levels of oxidatively modified proteins (Floyd, 1999; Gilgun-Sherki *et al.*, 2001). In AD, the major protein targets of oxidation have been found to be glutamine synthetase, creatine kinase and  $\alpha$ -enolase (Castegna *et al.*, 2002). Accumulation of damaged proteins is likely to account for the late onset of the aforementioned neurodegenerative disorders. The brain is particularly vulnerable to oxidative damage due to its abundant oxygen supply.

Redox-active transition metals mainly copper, manganese and iron, are proposed to be the main contributors to the onset of oxidative stress in the tissues of patients with neurodegenerative disorders (Sayre *et al.*, 2000). These metals are crucial for maintaining normal biochemical function within cells, functioning as co-factors for several enzymes, predominantly those involved in respiration. As a consequence, any reduction in the level of metal ions can give rise to compromised organ function,



and damage to the central nervous system. In contrast, an elevation in the level of metals has a cytotoxic effect, mainly due to an accompanying elevation in free radical concentrations, primarily via the Fenton reaction. In PD iron and lipid peroxide levels are elevated and glutathione levels are decreased, supporting the oxidative stress hypothesis. In AD aluminium, mercury, and iron are all contributory although iron is the most destructive. Metal ions can also directly interfere with the folding of protein and peptides by altering their conformations and ultimately their activities (Nomura and Sugiura, 2002; Bushmarina *et al.*, 2006).

## 2.5. Mitochondrial Antioxidant Defence Systems

Superoxide anions ( $O_2^{\cdot-}$ ) are reactive free radicals but can be converted to  $H_2O_2$  in the mitochondrial matrix by an organelle-specific,  $Mn^{2+}$ -dependent superoxide dismutase (SOD2). As charged species, they do not readily traverse membranes so, if not destroyed, they can cause oxidative damage to mitochondrial macromolecules in the vicinity. The rate of reaction between superoxide and nitric oxide (NO) is also extremely rapid ( $2 \times 10^{10} M^{-1} s^{-1}$ ) giving rise to peroxynitrite ( $ONOO^-$ ) which can also promote modification of biomolecules. So, high levels of SOD are required to compete for superoxide anions when NO is present.

The physiological importance of this mitochondrial isoform is evident, as mice lacking MnSOD die within the first 3 weeks of life from either severe cardiomyopathy or central nervous system degeneration, progressive motor disturbances and loss of mitochondrial integrity depending on the genetic background (Li *et al.*, 1995; Lebovitz *et al.*, 1996). Moreover, knockout mice heterozygous for SOD2 show a decline in cardiac mitochondrial function and enhanced rates of apoptosis (Van Remmen *et al.*, 2001). SOD only partially relieves oxidative stress in mitochondria, as its reaction product  $H_2O_2$  is itself a mild oxidant that is involved in the formation of highly-damaging hydroxyl radicals via the Fenton reaction in the presence of  $Cu^+$  or  $Fe^{2+}$ , which are abundant in this compartment.

Intracellular  $H_2O_2$  is mostly removed by the catalase, glutathione peroxidase (GPx) and the peroxiredoxin (Prxs) antioxidant defence systems. Catalase is a haem-containing enzyme that is located in peroxisomes in most tissues, rapidly breaks down  $H_2O_2$  to water and oxygen although a mitochondrial location has been reported in cardiac myocytes (Radi *et al.*, 1991). It is thought to remove  $H_2O_2$  that passively diffuses into the organelle or to prevent peroxide leakage from these oxidative bodies. However, GPx also catalyses the reduction of  $H_2O_2$  and various organic peroxides with glutathione as the electron donor. There are six Gpx isoforms in mammalian cells with GPx1, the major isoenzyme being expressed in all tissues. It is localised predominantly in the cytosol but a small proportion (30%) is reported to be present in the mitochondrial matrix (Brigelius-Flohé, 1999). Consequently, GPx1 was considered to play the primary role in protecting these organelles from oxidative damage. However, homozygous GPx1 knockout mice appear healthy and do not manifest an increased sensitivity to hyperoxia or show an increased content

of lipid carbonyl groups or lipid peroxides, suggesting that other mitochondrial antioxidant defence pathways are also involved in the protection from ROS.

Recently, the peroxiredoxin family has attracted considerable interest as a newly-emerging class of antioxidant enzymes that are major contributors to the regulation of intracellular  $H_2O_2$  levels where they are implicated in both tissue protection against oxidative stress and  $H_2O_2$ -mediated signalling pathways (Wood *et al.*, 2003). Their key role in antioxidant defence has been highlighted by their ubiquitous expression and high abundance in both bacterial and eukaryotic cells. In mammals, they can account for 0.1–0.8% of total cellular protein (Chae *et al.*, 1999) and up to 5% of mitochondrial matrix protein (Watabe *et al.*, 1994). In general terms, peroxiredoxins act as thioredoxin dependent peroxidases that display a broad substrate specificity with the ability to reduce,  $H_2O_2$ , organic peroxides and peroxynitrite (Chae *et al.*, 1999; Bryk *et al.*, 2000). AhpC from *S. typhimurium* was the first reported enzyme to catalytically reduce peroxynitrite to nitrite fast enough to forestall the damage of cellular components (Bryk *et al.*, 2000). Human peroxiredoxin V is also a peroxynitrite reductase with an unequalled high rate constant of  $(7 \pm 3) \times 10^7 M^{-1} s^{-1}$  (Dubuisson *et al.*, 2004) and it is likely that other members of this family have similar activity.

In yeast there are 5 separate peroxiredoxins located in different intracellular compartments that appear to play distinctive but overlapping roles (Wong *et al.*, 2004). For example, cytosolic thioredoxin peroxidase I (cTPxI) in *Saccharomyces cerevisiae* is constitutively expressed and relatively abundant compared to its close homologue and cytosolic partner cTPxII that is highly inducible by peroxides. cTPxII null strains exhibit a unique phenotype in which the cells acquire a high sensitivity to tert-butyl peroxide but remain resistant to  $H_2O_2$  (Munhoz and Netto, 2004). In contrast cells lacking cTPxI show increased sensitivity to both types of peroxide attack. These differing abilities to combat oxidative stress appear not to be related to the substrate specificities of cTPx I and II per se but reflect their capacity to act in concert with catalase to mount a concerted response to oxidative insult. Interestingly, a quintuple *S. cerevisiae* mutant, devoid of peroxiredoxin activity, is still viable but has a slower growth rate under normal aerobic conditions, is more susceptible to oxidative and nitrosative stress and exhibits genome instability (Munhoz and Netto, 2004). There is also enhanced production of glutathione peroxidase and glutathione reductase in this null strain which is also hypersensitive to glutathione depletion. These data suggest that, although the glutathione system can partially compensate for loss of peroxiredoxins in yeast, their presence is essential for normal cell development, proliferation and genome integrity.

## 2.6. Mitochondrial Thioredoxin and Thioredoxin Reductase

A slightly larger form of thioredoxin was first identified in pig heart mitochondria (Bodenstein and Follmann, 1991). This second Trx, Trx2, was cloned from a rat heart library and contained a putative 60 amino acid long N-terminal mitochondrial

targeting signal. Trx2 contains the conserved Trx catalytic site but lacks the other Cys residues found in mammalian Trx1 (Spyrou *et al.*, 1997).

The physiological roles of Trxs in different organisms range from a common fundamental reaction to a series of different specialized functions. Their primary highly conserved role is as a high-capacity hydrogen donor system for reductive enzymes to highly specialized functions such as forming a complex with apoptosis signal-regulating kinase 1 preventing downstream signalling for apoptosis (Saitoh *et al.*, 1998). Studies on Trx2 are limited but Trx2 has been shown to interact with specific components of the mitochondrial respiratory chain, play a key role in the regulation of the mitochondrial membrane potential (Damdimopoulos *et al.*, 2002) and also in protection against peroxide-induced apoptosis (Chen *et al.*, 2002).

Thioredoxin interacting protein (TrxIP, also known as vitamin-D3-upregulated protein-1, VDUP1) is a 50-kDa protein with structural homology to the arrestins. TrxIP was shown to form a mixed disulphide bond with the reduced form of Trx (Patwari *et al.*, 2006) inhibiting its function. As a result of this mechanism, overexpression of TrxIP inhibits thioredoxin reducing activity, so acting in a pro-oxidant capacity. Thus its down-regulation would be expected to enhance cellular responses to oxidative stress. TrxIP is generally up-regulated in situations leading to growth arrest and increased apoptosis (Nishiyama *et al.*, 1999; Junn *et al.*, 2000), while loss of expression is associated with tumor growth (Han *et al.*, 2003) indicating a possible role as a tumour suppressor.

Thioredoxin reductase is the only enzyme that is known to be able to reduce the active site of thioredoxin with the use of electrons from NADPH (Tamura and Stadtman, 1996). Mammalian TRR is distinct from those of prokaryotes and yeast. The mammalian enzyme exhibits a broader substrate specificity, having the ability to reduce chemically unrelated compounds and is larger in subunit size (58 kDa, compared with 35 kDa for the prokaryote and yeast enzymes), as it contains a much longer C-terminal region (Gasdaska *et al.*, 1995; Zhong *et al.*, 1998). In addition, mammalian TRR is a selenoprotein that contains a penultimate selenocysteine (SeCys) residue in the sequence –Gly-Cys-SeCys-Gly (Stadtman, 1996; Tamura and Stadtman, 1996), which serves as a redox centre (Arscott *et al.*, 1997).

Two full-length human thioredoxin reductases have been cloned, a 54.4 kDa thioredoxin reductase-1, which is predominantly in the cytosol (Gasdaska *et al.*, 1995), and a 56.2 kDa thioredoxin reductase-2, which has a 33-amino-acid N-terminal extension identified as a mitochondrial import sequence (Lee *et al.*, 1999).

A TRR2 mouse knockout study shows an essential role for TRR2 in hematopoiesis, heart development, and heart function (Conrad *et al.*, 2004). In this study also, cardiac tissue-restricted ablation of TRR2 results in fatal dilated cardiomyopathy, a condition reminiscent of that observed in Keshan disease and Friedreich's ataxia.

### 3. MITOCHONDRIAL Prxs

#### 3.1. PrxIII

PrxIII (also called SP-22) is a small (22kDa) mitochondrial protein that was originally isolated from bovine adrenal cortex as a substrate protein for a mitochondrial ATP-dependent protease (Watabe *et al.*, 1994; Watabe *et al.*, 1995). Analysis of its amino acid sequence revealed that PrxIII is a member of the Prx family and belongs to the typical 2-Cys PrxIII subclass. Among the members of this family, PrxIII is the only protein specifically located in mitochondria. Owing to the limited study of PrxIII at present, its exact physiological function *in vivo* and the biochemical mechanisms involved remain to be fully elucidated. However PrxIII has been demonstrated to protect several free-radical sensitive enzymes from oxidative damage *in vitro* (Watabe *et al.*, 1997). *In vivo*, current results indicate that PrxIII plays a crucial role in the antioxidant defence mechanism of mitochondria in the cardiovascular system (Araki *et al.*, 1999) and is also found to protect hippocampal neurons from excitotoxic injury (Hattori *et al.*, 2003).

A recent RNAi study in HeLa cells suggests PrxIII depletion promotes increased intracellular levels of H<sub>2</sub>O<sub>2</sub> and sensitizes cells to induction of apoptosis by staurosporine or TNF- $\alpha$  (Chang *et al.*, 2004). The authors conclude that PrxIII is a critical regulator of the abundance of mitochondrial H<sub>2</sub>O<sub>2</sub>, which itself induces apoptosis with other mediators of apoptotic signaling.

The amino acid sequence of PrxIII has been determined, in both its precursor and mature forms (Hiroi *et al.*, 1996). PrxIII has a 62 amino acid cleavable mitochondrial targeting sequence. By comparison with other 2-Cys Prxs, PrxIII also contains the conserved peroxidatic cysteine (C47), the resolving cysteine (C168) and a third cysteine residue C66.

The specific localization of PrxIII in mitochondria (Araki *et al.*, 1999) together with the identification of its mitochondria-specific electron suppliers, thioredoxin 2 (Trx2) and thioredoxin reductase 2 (TRR2) (Spyrou *et al.*, 1997; Lee *et al.*, 1999), suggest that these three proteins might cooperate to provide the primary line of defence against H<sub>2</sub>O<sub>2</sub> produced by the mitochondrial respiratory chain (Miranda-Vizuete *et al.*, 2000; Pedrajas *et al.*, 2000). Moreover, it has been shown that PrxIII is 30-fold more abundant in the mitochondria of HeLa cells than is GPx1 and is a key regulator of mitochondrial H<sub>2</sub>O<sub>2</sub> concentration, in contrast to the widely held view that GPx1 is the major H<sub>2</sub>O<sub>2</sub>-metabolizing enzyme in mitochondria (Turrens, 1997; de Haan *et al.*, 1998; Kokoszka *et al.*, 2001).

#### 3.2. PrxV

PrxV is an atypical 2-Cys Prx. The oxidized intermediate of atypical 2-Cys Prxs is a monomer containing an intramolecular Cys48-Cys152 disulphide bond (Seo *et al.*, 2000). Thioredoxin is the electron donor involved in disulphide bond reduction. Immunoblot analysis revealed that PrxV is widely expressed in rat tissues and cultured mammalian cells and is localized intracellularly to cytosol, mitochondria,

and peroxisomes (Seo *et al.*, 2000). PrxV has a mitochondrial pre-sequence at the N- terminus and a SQL peroxisomal targeting signal at the C terminus in the same protein (Knoops *et al.*, 1999). Overexpression of PrxV prevented the p53-dependent generation of reactive oxygen species. Likewise, PrxV inhibited p53-induced apoptosis (Zhou *et al.*, 2000). Human PrxV was also shown to protect mitochondrial DNA from damage induced by H<sub>2</sub>O<sub>2</sub> (Banmeyer *et al.*, 2005).

#### 4. STRUCTURE AND CATALYTIC MECHANISM OF PRXIII AND PRX V

##### 4.1. PrxIII

Transmission electron microscopy (Fig. 2) has shown that wild-type bovine PrxIII exists as an oligomeric ring, with external and internal diameters of 150 and 70 Å, respectively (Gourlay *et al.*, 2003). The size of the ring is larger than other typical 2-Cys Prxs that exist as decamers.

The crystal structure of mutant PrxIII C168S at 3.3Å showed that the monomeric PrxIII C168S is a compact globular structure, with the typical thioredoxin fold of the Prx family constructed around a seven-stranded, twisted β sheet surrounded by four α helices (Cao *et al.*, 2005). Individual subunits interact in a 'head-to-tail' fashion forming a functional dimeric unit in which the peroxidatic N-terminal cysteine (C47) forms a transient disulphide bond with the C-terminal (C168) resolving cysteine of the neighbouring monomer during the catalytic cycle. Initially, Cys47 is oxidized to cysteine sulphenic acid (CysOH) by H<sub>2</sub>O<sub>2</sub> prior to disulphide bond formation which results in the elimination of water. Reduction of the oxidized, disulphide-bonded form of PrxIII is accomplished by Trx2 in a reaction involving generation of a mixed disulphide intermediate. Recent studies have highlighted the susceptibility of the peroxidatic N-terminal cysteine of mammalian Prxs to inactivation by over-oxidation to cysteine sulphinic acid (CysO<sub>2</sub>H) and the possible additional roles for this residue in redox sensing and in the regulation of H<sub>2</sub>O<sub>2</sub>-mediated signaling pathways (see below for details).

The 6-fold NCS-related dimers are assembled into a dodecameric ring with outer and inner diameters of 150 and 70 Å, respectively (cf. 130 and 60 Å for the decameric Prxs). The dimer-dimer interfaces within the ring are formed mainly by hydrophobic residues, similar to the A-type interface (Sarma *et al.*, 2005). A similar dodecameric ring structure has also recently been reported for the crystal structure of MtAhpC<sub>C176S</sub> from *Mycobacterium tuberculosis* (Guimaraes *et al.*, 2005) and another 1-Cys Prx from the same organism has been shown to exist in an octameric organisation (Li *et al.*, 2005). These results show that 2-Cys Prx oligomers are not restricted to forming decameric toroids.

The most surprising feature of the crystal structure of PrxIII C168S is its presence as a two-ring catenane comprising two interlocking dodecameric toroids (Fig 3a) (Cao *et al.*, 2005). The planes of the rings are not at right angles, but are inclined at an angle of 55 degrees, which allows a larger contact surface between the rings. Indeed,

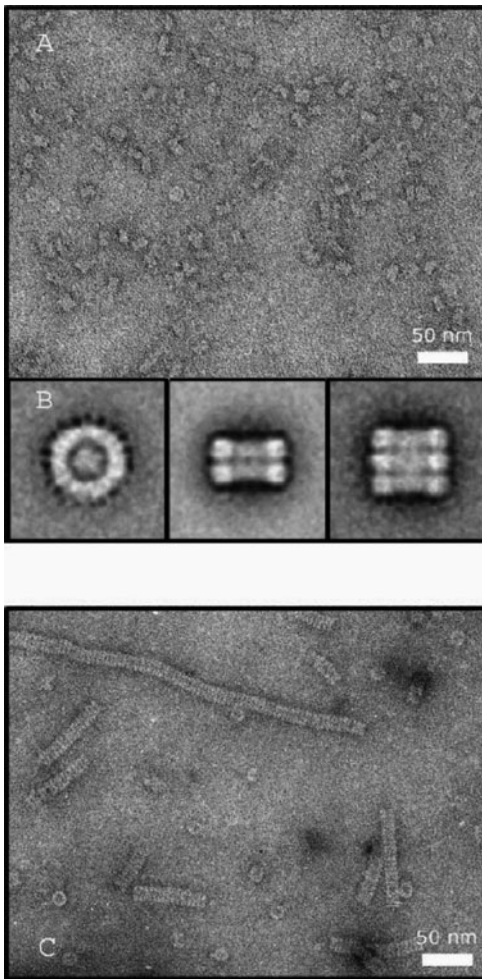

*Figure 2.* Transmission electron microscopy of PrxIII. A, electron micrograph of PrxIII; B, projection averages of the top view of PrxIII and the side views. Although purified PrxIII preparations are mostly single rings, there is significant lateral stacking to form double and triple toroids; C, electron micrograph of PrxIII C47S showing it has a pronounced tendency to form long filamentous structures of 60 rings or more. Adapted from (Gourlay *et al.*, 2003)

there are 12 areas of contact between the rings that are largely hydrophilic in nature. Thus, basic dimeric units have the potential to interact in two different modes: one mode produces the dimer-dimer contacts, primarily hydrophobic, associated with ring generation in this and other Prx structures while the other involves polar contacts that could potentially initiate catenane formation at any stage during single toroid assembly by allowing two rings to form simultaneously around each other. Whether the catenated form of PrxIII has any physiological relevance is not clear

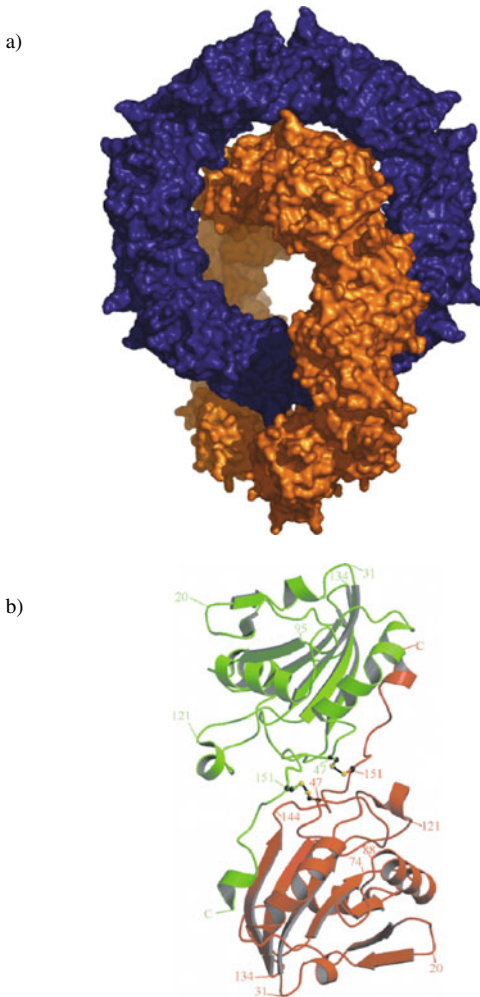

*Figure 3.* Crystal structures of mitochondrial Prxs a) Surface diagram of the catenane structure of PrxIII C168S. The overall structure of the two interlocking rings is shown in blue and gold respectively. The figure was produced using the program PyMOL (Delano, 2002b) The crystal structure of human PrxV shown in ribbon diagram with the two oxidized dimers coloured green and red. The Cys residues taking part in intermolecular disulphide bond formation are also shown. Adapted from (Evrard *et al.*, 2004) (See Plate 20)

at present. Recent observations that Prxs can protect cells from heat shock in a peroxidase-independent process might provide new insights into possible novel functions (Jang *et al.*, 2004). The authors found that in their lower molecular weight dimeric and decameric forms cPrxI and II display peroxidase activity while under oxidative stress or heat shock exposure in yeast, the Prxs are over-oxidised and assemble into higher molecular weight complexes of undefined subunit organisation

at present which appear to exert a protective function and have been designated as super-chaperones.

It should be noted that the Prx structure undergoes large conformational changes in the monomer during oxidation and reduction (Wood *et al.*, 2003). As a general property of Prxs, the two catalytic cysteines are separated by approximately 13Å in the reduced state but form a disulphide bond in the oxidized enzyme. Thus, the reduced enzyme and the conserved cysteine mutants (*e.g* the C168S mutant of PrxIII) that are incapable of disulphide bond formation are structurally equivalent to the over-oxidised form. During catalysis, the structure will transform rapidly between its oxidised and reduced states, a process that also involves transient generation of covalent links between adjacent monomers in the basic functional dimeric unit. However, there is increasing evidence to show that the conserved cysteines may play a role as hydrogen peroxide “sensors” in addition to their catalytic role. At elevated hydrogen peroxide levels, PrxI will be over-oxidized triggering assembly into high molecular weight complexes with altered functions. It is possible that the ability of Prxs to associate into oligomeric rings of various sizes, super chaperone complexes or even catenane structures might be essential for activating these novel functional properties. In this connection, a screen for unknown candidate proteins which can interact with Prxs in their various oligomeric states might provide important clues as to the diversity of physiological roles attributable to this interesting family of antioxidant enzymes.

There are three previous examples of protein catenanes cited in the literature and two of them are rather specialised cases. One is a totally artificially-produced peptide catenane based on a small segment of a dimeric mutant of the p53tet protein generated *in vitro* using chemical techniques (Yan and Dawson, 2001). The other one is a viral capsid assembly of 420 subunits where the subunits are topologically linked by covalent (isopeptide) bonds creating a form of protein ‘chain mail’ which is highly resistant to degradation (Wikoff *et al.*, 2000). The third case is the crystal structure of RecR from *Deinococcus radiodurans*, which is involved in homologous recombinational DNA repair in procaryotes (PDB id: 1VDD) and is also present as a protein catenane (Lee *et al.*, 2004). The structures of RecR and PrxIII C168S show that proteins are also able to form catenanes although these are extremely rare at present.

#### 4.2. PrxV

Both human and mouse PrxV sequences contain the conserved Cys47 and also Cys72 and Cys151. However, the sequences surrounding Cys72 and Cys151 are not as conserved as those surrounding the C-terminal Cys residue of typical 2-Cys Prx enzymes. Cys47 is the site of oxidation by peroxides, and the resulting oxidized Cys47 reacts with the thiol group of Cys151 to form a disulphide linkage, which was initially suggested to be intramolecular based on biochemical data (Seo *et al.*, 2000). However, recent crystal structures indicate that the initial oxidation state of Prx V contains two intermolecular disulphide bonds which subsequently rearrange



to form intramolecular disulphides (Fig. 3b) (Evrard *et al.*, 2004). The comparison of the reduced form and the oxidized form of PrxV showed a partial unwinding of the N-terminal parts of the  $\alpha 2$  helix which contains the peroxidatic cysteine 47 and  $\alpha 6$  helix, which is close to the resolving cysteine 151, to allow the formation of the disulphide bond. In the oxidized dimer of the crystal structure, the  $\alpha 6$  arm which belongs to the first monomer in the reduced form, now appears at the surface of the second subunit (Evrard *et al.*, 2004).

## 5. BIOCHEMICAL PROPERTIES OF THE RECONSTITUTED PRXIII PATHWAY AND REGULATION OF PRXIII OLIGOMERIC STATE

The entire mitochondrial PrxIII antioxidant defence pathway *in vitro* has been reconstituted in our laboratory by completing the cloning, overexpression and purification of PrxIII, Trx2 and TRR2 (Fig. 4). The results show, particularly at low  $H_2O_2$  concentrations in the physiological range, that the presence of all three pathway components is essential for reconstitution of activity.

At  $H_2O_2$  concentration where progressive inhibition of activity is evident owing to inactivation of PrxIII (data not shown). Interestingly a second peak of peroxidase activity at non-physiological  $H_2O_2$  levels which attachable to TRR2 activity alone appears to relate to leakage of electrons from the edge of the flavin ring onto dissolved oxygen to form  $H_2O_2$  in solution (Gazaryan *et al.*, 2002).

The susceptibility of other Prxs to over-oxidation has been reported previously (Yang *et al.*, 2002) and has provided the basis for the development of the floodgate theory (Wood *et al.*, 2003). This theory proposes that at low  $H_2O_2$  concentrations, Prxs will play an anti-oxidant defence role in reducing  $H_2O_2$  levels. However,

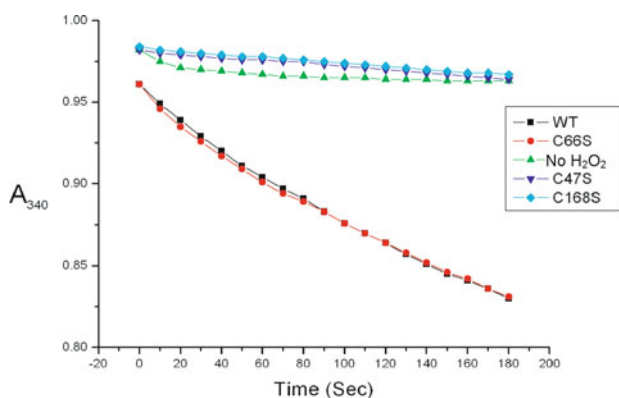

*Figure 4.* Time course of PrxIII-dependent NADPH oxidation coupled to  $H_2O_2$  reduction for various Cys mutants of PrxIII NADPH oxidation was monitored at 340nm. The reaction without  $H_2O_2$  (green line) was used as the negative control while the reaction with wild-type PrxIII (black line) was used as positive control (See Plate 21)

when  $H_2O_2$  concentrations are elevated sufficiently, the Prxs will tend to lose activity allowing  $H_2O_2$  to act in a signaling capacity. The results for PrxIII also agree with this observation and can be monitored by SDS-PAGE analysis in the absence of DTT. Conversion of monomeric PrxIII subunits (reduced) to the oxidised, doubly disulphide-bonded dimeric state is readily observed on addition of  $H_2O_2$  to the native enzyme. At elevated  $H_2O_2$  levels, a dimeric band of lower mobility appears consistent with partial overoxidation of the catalytic cysteines leading to the formation of a more extended, singly disulphide-bonded intermediate. At high (non-physiological levels) of peroxide substrate, monomer to dimer conversion is also inhibited indicating complete over-oxidation of the cysteines involved in disulphide bond formation. Wood *et al.* (2003) also find that the AhpC, a bacterial peroxiredoxin, is more than 100 times less susceptible to over-oxidation than human Prx I. Thus they have concluded that bacterial peroxiredoxins only behave as antioxidants, whereas their eukaryotic counterparts also regulate  $H_2O_2$ -mediated signaling.

Until recently the over-oxidation of Prxs was thought to be irreversible. However, Wood *et al.* (2003) showed that the sulphinic acid form of PrxI, produced during the exposure of cells to  $H_2O_2$ , is rapidly reduced to the catalytically active thiol form. A protein called sulphiredoxin (Srx), which was first identified in yeast and conserved in higher eukaryotes, was found to be able to reduce cysteine-sulphinic acid in the yeast peroxiredoxin Tsa1 (Biteau *et al.*, 2003). The ability of eukaryote cells to repair the over-oxidized protein suggests their function is also subject to redox-mediated regulation. Srx contains a C-terminal cysteine residue that is conserved in all family members. Studies with the yeast and human homologue show this residue is critical for its antioxidant function (Biteau *et al.*, 2003). Inactivated Prxs can be reduced by Srx and ATP. A recent study on the molecular mechanism of the reduction of cysteine sulphinic acid of peroxiredoxin to cysteine by mammalian sulphiredoxin reveals that the presence of the sulphinic form (but not the reduced form) of PrxI induces phosphorylation of the conserved cysteine of Srx as part of the catalytic cycle (Jeong *et al.*, 2006).

## 6. CONCLUDING REMARKS

Despite recent rapid developments in our understanding of Prx structure (see Table 1), organisation and function of mitochondrial peroxiredoxins in parallel with advances in our knowledge on the peroxiredoxin family in general, much remains to be learned about their precise physiological roles, interplay with other antioxidant defence systems and specific engagement with cell signalling pathways. The relative contributions of PrxIII and PrxV to the protection of mitochondria from oxidative attack is also a subject for future investigation as both function as thioredoxin-dependent peroxidases that presumably have to compete for a single intra-mitochondrial pool of Trx2. It seems probable that the mitochondrial Prxs will form a vital link in an integrated network of antioxidant defence systems involved in cellular damage limitation and ensuring that cells respond appropriately

Table 1. Summary of current information on crystal structures and subunit organisation of prxs

PDB ID	Res	Prx type	Oligomeric state	Year	Name
1prx	2.0A	1-cys	2	1998	Human open reading frame 6 (hORF6) (Choi et al., 1998)
1xcc	2.3A	1-cys	2	2004	1-Cys peroxiredoxin from <i>Plasmodium yoelli</i> (To be published)
1xiy	1.8A	1-cys	2	2004	1-Cys peroxiredoxin from <i>Plasmodium falciparum</i> (Sarma et al., 2005)
1xvw	1.9A	1-cys	8	2004	AhpE from <i>Mycobacterium tuberculosis</i> (Li et al., 2005)
1hd2	1.5A	atypical	1	2000	Human Prx5 (Declercq et al., 2001)
1nm3	2.8A	atypical	2	2003	<i>Haemophilus influenzae</i> Hybrid-Prx5 (Kim et al., 2003)
1psq	2.3A	atypical	2	2003	Probable thiol peroxidase from <i>Streptococcus pneumoniae</i> (To be published)
1qxx	2.2A	atypical	2	2003	Thiol peroxidase from <i>Escherichia coli</i> (Choi et al., 2003)
1q98	1.9A	atypical	2	2003	Thiol peroxidase from <i>Haemophilus influenzae</i> (To be published)
1e2y	3.2A	typical	10	2000	Tryparedoxin peroxidase from <i>Crithidia fasciculata</i> (Alphey et al., 2000)
1n8j	2.17A	typical	10	2002	Alkyl hydroperoxide reductase C (AhpC) C46S (Wood et al., 2003)
1qmv	1.7A	typical	10	1999	Thioredoxin peroxidase B (TPxB) from red blood cells (Schroder et al., 2000)
1qq2	2.6A	typical	2	1999	Heme-binding protein 23 (HBP23) (Hirotsu et al., 1999)
1tp9	1.62A	typical	2	2004	Prx D (Type II) from <i>Populus tremula</i> (Echalier et al., 2005)
1uul	2.8A	typical	10	2003	Tryparedoxin peroxidase from <i>Trypanosoma cruzi</i> (Pineyro et al., 2005)
1vgs	2.31A	typical	10	2004	Peroxiredoxin from <i>Aeropyrum pernix K1</i> (Mizohata et al., 2005)
1we0	2.9A	typical	10	2004	AhpC from <i>Amphibacillus xylanus</i> (Kitano et al., 2005)
2bmx	2.4A	typical	12	2005	AhpC from <i>Mycobacterium tuberculosis</i> (Guimaraes et al., 2005)
1zye	3.3A	typical	12	2005	Bovine PrxIII (Cao et al., 2005)

to alterations in ROS levels via the H<sub>2</sub>O<sub>2</sub>-mediated regulation of key cell signalling pathways. To what extent these mitochondrially located peroxidases play distinctive or overlapping roles and act in concert with other intracellular regulators of ROS are clearly key issues that require to be addressed as a matter of urgency over the next few years.

## REFERENCES

- Araki, M., Nanri, H., Ejima, K., Murasato, Y., Fujiwara, T., Nakashima, Y. and Ikeda, M., 1999, Antioxidant function of the mitochondrial protein SP-22 in the cardiovascular system. *J. Biol. Chem.* **274**: 2271–2278.
- Arcott, L. D., Gromer, S., Schirmer, R. H., Becker, K., Williams, C. H., Jr., 1997, The mechanism of thioredoxin reductase from human placenta is similar to the mechanisms of lipoamide dehydrogenase and glutathione reductase and is distinct from the mechanism of thioredoxin reductase from *Escherichia coli*. *Proc. Natl. Acad. Sci. USA* **94**: 3621–3626.
- Aust, A. E., Eveleigh, J. F., 1999, Mechanisms of DNA oxidation. *Proc. Soc. Exp. Biol. Med.* **222**: 246–252.
- Banmeyer, I., Marchand, C., Clippe, A., Knoops, B., 2005, Human mitochondrial peroxiredoxin 5 protects from mitochondrial DNA damages induced by hydrogen peroxide. *FEBS Lett.* **579**: 2327–2333.
- Berlett, B.S., Stadtman, E.R., 1997, Protein oxidation in aging, disease, and oxidative stress. *J. Biol. Chem.* **272**: 20313–20316.
- Biteau, B., Labarre, J., Toledano, M. B., 2003, ATP-dependent reduction of cysteine-sulphinic acid by *S. cerevisiae* sulphiredoxin. *Nature* **425**: 980–984.
- Bodenstein, J., Follmann, H., 1991, Characterization of two thioredoxins in pig heart including a new mitochondrial protein. *Z. Naturforsch. [C]* **46**: 270–279.
- Brigelius-Flohé, R., 1999, Tissue-specific functions of individual glutathione peroxidases. *Free Radic. Biol. Med.* **27**: 951–965.
- Bryk, R., Griffin, P., Nathan, C., 2000, Peroxynitrite reductase activity of bacterial peroxiredoxins. *Nature* **407**: 211–215.
- Bushmarina, N.A., Blanchet, C.E., Vernier, G., Forge, V., 2006, Cofactor effects on the protein folding reaction: acceleration of alpha-lactalbumin refolding by metal ions. *Protein Sci.* **15**: 659–671.
- Cabiscol, E., Piulats, E., Echave, P., Herrero, E., Ros, J., 2000, Oxidative stress promotes specific protein damage in *Saccharomyces cerevisiae*. *J. Biol. Chem.* **275**: 27393–27398.
- Cadenas, E., Davies, K.J., 2000, Mitochondrial free radical generation, oxidative stress, and aging. *Free Radic. Biol. Med.* **29**: 222–230.
- Calabrese, V., Scapagnini, G., Ravagna, A., Fariello, R.G., Giuffrida, S.A.M. Abraham, N.G., 2002, Regional distribution of heme oxygenase, HSP70, and glutathione in brain: relevance for endogenous oxidant/antioxidant balance and stress tolerance. *J. Neurosci. Res.* **68**: 65–75.
- Cao, Z., Roszak, A.W., Gourlay, L.J., Lindsay, J.G., Isaacs, N.W., 2005, Bovine mitochondrial peroxiredoxin III forms a two-ring catenane. *Structure (Camb)* **13**: 1661–1664.
- Castegna, A., Aksenov, M., Thongboonkerd, V., Klein, J.B., Pierce, W.M., Booze, R., Markesbery, W.R., Butterfield, D.A. (2002). Proteomic identification of oxidatively modified proteins in Alzheimer's disease brain. Part II: dihydropyrimidinase-related protein 2, alpha-enolase and heat shock cognate 71. *J. Neurochem.* **82**: 1524–1532.
- Chae, H.Z., Kim, H.J., Kang, S.W., Rhee, S. G., 1999, Characterization of three isoforms of mammalian peroxiredoxin that reduce peroxides in the presence of thioredoxin. *Diabetes Res. Clin. Pract.* **45**: 101–112.
- Chang, T.S., Cho, C.S., Park, S., Yu, S., Kang, S.W., Rhee, S.G., 2004, Peroxiredoxin III, a mitochondrion-specific peroxidase, regulates apoptotic signaling by mitochondria. *J. Biol. Chem.* **279**: 41975–41984.
- Chen, Y., Cai, J., Murphy, T.J., Jones, D.P., 2002, Overexpressed human mitochondrial thioredoxin confers resistance to oxidant-induced apoptosis in human osteosarcoma cells. *J. Biol. Chem.* **277**: 33242–33248.
- Conrad, M., Jakupoglu, C., Moreno, S.G., Lippl, S., Banjac, A., Schneider, M., Beck, H., Hatzopoulos, A. K., Just, U., Sinowatz, F., Schmahl, W., Chien, K.R., Wurst, W., Bornkamm, G.W., Brielmeier, M., 2004, Essential role for mitochondrial thioredoxin reductase in hematopoiesis, heart development, and heart function. *Mol. Cell Biol.* **24**: 9414–9423.

- Damdimopoulos, A.E., Miranda-Vizuete, A., Pelto-Huikko, M., Gustafsson, J.A., Spyrou, G., 2002, Human mitochondrial thioredoxin. Involvement in mitochondrial membrane potential and cell death. *J. Biol. Chem.* **277**: 33249–33257.
- de Haan, J.B., Bladier, C., Griffiths, P., Kelner, M., O'Shea, R.D., Cheung, N.S., Bronson, R.T., Silvestro, M.J., Wild, S., Zheng, S.S., Beart, P.M., Hertzog, P. J., Kola, I., 1998, Mice with a homozygous null mutation for the most abundant glutathione peroxidase, Gpx1, show increased susceptibility to the oxidative stress-inducing agents paraquat and hydrogen peroxide. *J. Biol. Chem.* **273**: 22528–22536.
- Delano, W.L., 2002, The PyMOL Molecular Graphics System, Delano Scientific, San Carlos, CA, USA.
- Dubuisson, M., Vander Stricht, D., Clippe, A., Etienne, F., Nauser, T., Kissner, R., Koppenol, W.H., Rees, J.F., Knoop, B., 2004, Human peroxiredoxin 5 is a peroxynitrite reductase. *FEBS Lett.* **571**: 161–165.
- Esterbauer, H., Schaur, R.J., Zollner, H., 1991, Chemistry and biochemistry of 4-hydroxynonenal, malonaldehyde and related aldehydes. *Free Radic. Biol. Med.* **11**: 81–128.
- Esteve, J.M., Mompou, J., Garcia de la Asuncion, J., Sastre, J., Asensi, M., Boix, J., Vina, J.R., Vina, J., Pallardo, F.V., 1999, Oxidative damage to mitochondrial DNA and glutathione oxidation in apoptosis: studies in vivo and in vitro. *FASEB J.* **13**: 1055–1064.
- Evrard, C., Capron, A., Marchand, C., Clippe, A., Wattiez, R., Soumillion, P., Knoop, B., Declercq, J.P., 2004, Crystal structure of a dimeric oxidized form of human peroxiredoxin 5. *J. Mol. Biol.* **337**: 1079–1090.
- Floyd, R.A., 1999, Antioxidants, oxidative stress, and degenerative neurological disorders. *Proc. Soc. Exp. Biol. Med.* **222**: 236–245.
- Gasdaska, P.Y., Gasdaska, J.R., Cochran, S., Powis, G., 1995, Cloning and sequencing of a human thioredoxin reductase. *FEBS Lett.* **373**: 5–9.
- Gazaryan, I.G., Krasnikov, B.F., Ashby, G.A., Thorneley, R.N., Kristal, B.S., Brown, A.M., 2002, Zinc is a potent inhibitor of thiol oxidoreductase activity and stimulates reactive oxygen species production by lipamide dehydrogenase. *J. Biol. Chem.* **277**: 10064–10072.
- Gilgun-Sherki, Y., Melamed, E. and Offen, D., 2001, Oxidative stress induced-neurodegenerative diseases: the need for antioxidants that penetrate the blood brain barrier. *Neuropharmacology* **40**: 959–975.
- GOROG, D.A., Ahmed, N., Davies, G.J., 2002, Elevated plasma lipid peroxide levels in angina pectoris and myocardial infarction. *Cardiovasc. Pathol.* **11**: 153–157.
- Gourlay, L.J., Bhella, D., Kelly, S.M., Price, N.C., Lindsay, J.G., 2003, Structure-function analysis of recombinant substrate protein 22 kDa (SP-22). A mitochondrial 2-CYS peroxiredoxin organized as a decameric toroid. *J. Biol. Chem.* **278**: 32631–32637.
- Green, D.R., Reed, J. C., 1998, Mitochondria and apoptosis. *Science* **281**: 1309–1312.
- Guimaraes, B.G., Souchon, H., Honore, N., Saint-Joanis, B., Brosch, R., Shepard, W., Cole, S.T., Alzari, P.M., 2005, Structure and mechanism of the alkyl hydroperoxidase AhpC, a key element of the Mycobacterium tuberculosis defense system against oxidative stress. *J. Biol. Chem.* **280**: 25735–25742.
- Han, S.H., Jeon, J.H., Ju, H.R., Jung, U., Kim, K.Y., Yoo, H.S., Lee, Y.H., Song, K.S., Hwang, H.M., Na, Y.S., Yang, Y., Lee, K.N., Choi, I., 2003, VDUP1 upregulated by TGF-beta1 and 1,25-dihydroxyvitamin D3 inhibits tumor cell growth by blocking cell-cycle progression. *Oncogene* **22**: 4035–4046.
- Hattori, F., Murayama, N., Noshita, T., Oikawa, S., 2003, Mitochondrial peroxiredoxin-3 protects hippocampal neurons from excitotoxic injury in vivo. *J. Neurochem.* **86**: 860–868.
- Henle, E.S., Linn, S., 1997, Formation, prevention, and repair of DNA damage by iron/hydrogen peroxide. *J. Biol. Chem.* **272**: 19095–19098.
- Ishii, N., Fujii, M., Hartman, P. S., Tsuda, M., Yasuda, K., Senoo-Matsuda, N., Yanase, S., Ayusawa, D., Suzuki, K., 1998, A mutation in succinate dehydrogenase cytochrome b causes oxidative stress and ageing in nematodes. *Nature* **394**: 694–697.
- Jang, H.H., Lee, K.O., Chi, Y.H., Jung, B.G., Park, S.K., Park, J.H., Lee, J.R., Lee, S.S., Moon, J.C., Yun, J.W., Choi, Y.O., Kim, W.Y., Kang, J.S., Cheong, G.W., Yun, D.J., Rhee, S.G., Cho, M.J.,

- Lee, S.Y., 2004, Two enzymes in one; two yeast peroxiredoxins display oxidative stress-dependent switching from a peroxidase to a molecular chaperone function. *Cell* **117**: 625–635.
- Jeong, W., Park, S.J., Chang, T.S., Lee, D.Y., Rhee, S.G., 2006, Molecular mechanism of the reduction of cysteine sulfinic acid of peroxiredoxin to cysteine by mammalian sulfiredoxin. *J. Biol. Chem.* **281**: 14400–14407.
- Junn, E., Han, S.H., Im, J.Y., Yang, Y., Cho, E.W., Um, H.D., Kim, D.K., Lee, K.W., Han, P.L., Rhee, S.G., Choi, I., 2000, Vitamin D3 up-regulated protein 1 mediates oxidative stress via suppressing the thioredoxin function. *J. Immunol.* **164**: 6287–6295.
- Kasai, H., Nishimura, S., Kurokawa, Y., Hayashi, Y., 1987, Oral administration of the renal carcinogen, potassium bromate, specifically produces 8-hydroxydeoxyguanosine in rat target organ DNA. *Carcinogenesis* **8**: 1959–1961.
- Knoops, B., Clippe, A., Bogard, C., Arsalane, K., Wattiez, R., Hermans, C., Duconseille, E., Falmagne, P., Bernard, A., 1999, Cloning and characterization of AOEB166, a novel mammalian antioxidant enzyme of the peroxiredoxin family. *J. Biol. Chem.* **274**: 30451–30458.
- Kokoszka, J.E., Coskun, P., Esposito, L.A., Wallace, D.C., 2001, Increased mitochondrial oxidative stress in the Sod2 (+/−) mouse results in the age-related decline of mitochondrial function culminating in increased apoptosis. *Proc. Natl. Acad. Sci. USA* **98**: 2278–2283.
- Kroemer, R., Reed, J.C., 2000, Mitochondrial control of cell death. *Nat. Med.* **6**: 513–519.
- Lebovitz, R.M., Zhang, H., Vogel, H., Cartwright, J., Jr., Dionne, L., Lu, N., Huang, S., Matzuk, M.M., 1996, Neurodegeneration, myocardial injury, and perinatal death in mitochondrial superoxide dismutase-deficient mice. *Proc. Natl. Acad. Sci. USA* **93**: 9782–9787.
- Lee, B.I., Kim, K.H., Park, S.J., Eom, S.H., Song, H.K., Suh, S.W., 2004, Ring-shaped architecture of RecR: implications for its role in homologous recombinational DNA repair. *EMBO J.* **23**: 2029–3038.
- Lee, S.R., Kim, J.R., Kwon, K.S., Yoon, H.W., Levine, R.L., Ginsburg, A., Rhee, S.G., 1999, Molecular cloning and characterization of a mitochondrial selenocysteine-containing thioredoxin reductase from rat liver. *J. Biol. Chem.* **274**: 4722–4734.
- Li, S., Peterson, N.A., Kim, M.Y., Kim, C.Y., Hung, L.W., Yu, M., Lakin, T., Segelke, B.W., Lott, J.S., Baker, E.N., 2005). Crystal Structure of AhpE from *Mycobacterium tuberculosis*, a 1-Cys peroxiredoxin. *J. Mol. Biol.* **346**: 1035–1046.
- Li, Y., Huang, T.T., Carlson, E.J., Melov, S., Ursell, P.C., Olson, J.L., Noble, L.J., Yoshimura, M.P., Berger, C., Chan, P.H., Wallace, D.C., Epstein, C.J., 1995, Dilated cardiomyopathy and neonatal lethality in mutant mice lacking manganese superoxide dismutase. *Nat. Genet.* **11**: 376–381.
- Loschen, G., Flohé, L., and Chance, B., 1971, Respiratory chain linked H<sub>2</sub>O<sub>2</sub> production in pigeon heart mitochondria. *FEBS Lett.* **18**: 261–264.
- Loschen, G., Azzí, A., Richter, Ch., and Flohé, L., 1974, Superoxide radicals as precursors of mitochondrial hydrogen peroxide. *FEBS Lett.* **42**: 68–72.
- Marnett, L.J., 1999, Lipid peroxidation-DNA damage by malondialdehyde. *Mutat. Res.* **424**(: 83–95.
- Marnett, L.J., 2000, Oxyradicals and DNA damage. *Carcinogenesis* **2**: 361–370.
- Miranda-Vizuete, A., Damdimopoulos, A.E., Spyrou, G., 2000, The mitochondrial thioredoxin system. *Antioxid. Redox. Signal.* **2**: 801–810.
- Munhoz, D.C., Netto, L.E., 2004, Cytosolic thioredoxin peroxidase I and II are important defenses of yeast against organic hydroperoxide insult: catalases and peroxiredoxins cooperate in the decomposition of H<sub>2</sub>O<sub>2</sub> by yeast. *J. Biol. Chem.* **279**: 35219–35227.
- Newmeyer, D.D., Ferguson-Miller, S., 2003, Mitochondria: releasing power for life and unleashing the machineries of death. *Cell* **112**: 481–490.
- Nishiyama, A., Matsui, M., Iwata, S., Hirota, K., Masutani, H., Nakamura, H., Takagi, Y., Sono, H., Gon, Y., Yodoi, J., 1999, Identification of thioredoxin-binding protein-2/vitamin D(3) up-regulated protein 1 as a negative regulator of thioredoxin function and expression. *J. Biol. Chem.* **274**: 21645–21650.
- Nomura, A., Sugiura, Y., 2002, Contribution of individual zinc ligands to metal binding and peptide folding of zinc finger peptides. *Inorg. Chem.* **41**: 3693–3698.
- Patwari, P., Higgins, L.J., Chutkow, W A., Yoshioka, J., Lee, R.T., 2006, The interaction of thioredoxin with Txnip: Evidence for formation of a mixed disulfide by disulfide exchange. *J. Biol. Chem.* **281**: 21884–21891.

- Pedrajas, J.R., Miranda-Vizuete, A., Javanmardy, N., Gustafsson, J.A., Spyrou, G., 2000, Mitochondria of *Saccharomyces cerevisiae* contain one-conserved cysteine type peroxiredoxin with thioredoxin peroxidase activity. *J. Biol. Chem.* **275**: 16296–16301.
- Radi, R., Turrens, J.F., Chang, L.Y., Bush, K.M., Crapo, J.D., Freeman, B.A., 1991. Detection of catalase in rat heart mitochondria. *J. Biol. Chem.* **266**: 22028–22034.
- Saitoh, M., Nishitoh, H., Fujii, M., Takeda, K., Tobiume, K., Sawada, Y., Kawabata, M., Miyazono, K., Ichijo, H., 1998 Mammalian thioredoxin is a direct inhibitor of apoptosis signal-regulating kinase (ASK) 1. *EMBO J.* **17**: 2596–2606.
- Sarma, G.N., Nickel, C., Rahlfs, S., Fischer, M., Becker, K., Karplus, P.A., 2005, Crystal structure of a novel *Plasmodium falciparum* 1-Cys peroxiredoxin. *J. Mol. Biol.* **346**: 1021–1034.
- Sayre, L.M., Perry, G., Atwood, C.S., Smith, M.A., 2000, The role of metals in neurodegenerative diseases. *Cell. Mol. Biol. (Noisy-le-grand)* **46**: 731–741.
- Seo, M.S., Kang, S.W., Kim, K., Baines, I.C., Lee, T.H., Rhee, S.G., 2000, Identification of a new type of mammalian peroxiredoxin that forms an intramolecular disulfide as a reaction intermediate. *J. Biol. Chem.* **275**: 20346–20354.
- Shibutani, S., Takeshita, M., Grollman, A.P., 1991, Insertion of specific bases during DNA synthesis past the oxidation-damaged base 8-oxodG. *Nature* **349**: 431–434.
- Spyrou, G., Enmark, E., Miranda-Vizuete, A., Gustafsson, J., 1997, Cloning and expression of a novel mammalian thioredoxin. *J. Biol. Chem.* **272**: 2936–2941.
- Stadtman, E.R., Berlett, B.S., 1991, Fenton chemistry. Amino acid oxidation. *J. Biol. Chem.* **266**: 17201–17211.
- Stadtman, T.C., 1996, Selenocysteine. *Ann. Rev. Biochem.* **65**: 83–100.
- Starkov, A.A., Fiskum, G., Chinopoulos, C., Lorenzo, B.J., Browne, S.E., Patel, M. S., Beal, M.F., 2004, Mitochondrial alpha-ketoglutarate dehydrogenase complex generates reactive oxygen species. *J. Neurosci.* **24**: 7779–7788.
- Tamarit, J., Cabiscol, E., Ros, J., 1998, Identification of the major oxidatively damaged proteins in *Escherichia coli* cells exposed to oxidative stress. *J. Biol. Chem.* **273**: 3027–3032.
- Tamura, T., Stadtman, T.C., 1996, A new selenoprotein from human lung adenocarcinoma cells: purification, properties, and thioredoxin reductase activity. *Proc. Natl. Acad. Sci. USA* **93**: 1006–1011.
- Tretter, L., Adam-Vizi, V., 2004, Generation of reactive oxygen species in the reaction catalyzed by alpha-ketoglutarate dehydrogenase. *J. Neurosci.* **24**: 7771–7778.
- Turrens, J.F., 1997, Superoxide production by the mitochondrial respiratory chain. *Biosci. Rep.* **17**: 3–8.
- Van Remmen, H., Williams, M.D., Guo, Z., Estlack, L., Yang, H., Carlson, E.J., Epstein, C.J., Huang, T.T., Richardson, A., 2001, Knockout mice heterozygous for *Sod2* show alterations in cardiac mitochondrial function and apoptosis. *Am. J. Physiol. Heart Circ. Physiol.* **281**: H1422–1432.
- Watabe, S., Hasegawa, H., Takimoto, K., Yamamoto, Y. and Takahashi, S.Y., 1995, Possible function of SP-22, a substrate of mitochondrial ATP-dependent protease, as a radical scavenger. *Biochem. Biophys. Res. Commun.* **213**: 1010–1016.
- Watabe, S., Hiroi, T., Yamamoto, Y., Fujioka, Y., Hasegawa, H., Yago, N., Takahashi, S.Y., 1997, SP-22 is a thioredoxin-dependent peroxide reductase in mitochondria. *Eur. J. Biochem.* **249**: 52–60.
- Watabe, S., Kohno, H., Kouyama, H., Hiroi, T., Yago, N., Nakazawa, T., 1994, Purification and characterization of a substrate protein for mitochondrial ATP-dependent protease in bovine adrenal cortex. *J. Biochem. (Tokyo)* **115**: 648–654.
- Wei, Y.H., Lee, H.C., 2002, Oxidative stress, mitochondrial DNA mutation, and impairment of antioxidant enzymes in aging. *Exp. Biol. Med. (Maywood)* **227**: 671–682.
- Wikoff, W.R., Liljas, L., Duda, R.L., Tsuruta, H., Hendrix, R.W. and Johnson, J.E., 200., Topologically linked protein rings in the bacteriophage HK97 capsid. *Science* **289**: 2129–2133.
- Wong, C.M., Siu, K.L., Jin, D.Y., 2004, Peroxiredoxin-null yeast cells are hypersensitive to oxidative stress and are genomically unstable. *J. Biol. Chem.* **279**: 23207–23213.
- Wood, Z.A., Poole, L.B., Karplus, P.A., 2003, Peroxiredoxin evolution and the regulation of hydrogen peroxide signaling. *Science* **300**: 650–653.
- Wood, Z. A., Schröder, E., Harris, J.R., Poole, L.B., 2003, Structure, mechanism and regulation of peroxiredoxins. *Trends Biochem. Sci.* **28**: 32–40.

- Yan, L.Z., Dawson, P.E., 2001, Design and Synthesis of a Protein Catenane. *Angew. Chem. Int. Ed. Engl.* **40**: 3625–3627.
- Yang, K.S., Kang, S.W., Woo, H.A., Hwang, S.C., Chae, H.Z., Kim, K., Rhee, S.G., 2002, Inactivation of human peroxiredoxin I during catalysis as the result of the oxidation of the catalytic site cysteine to cysteine-sulfinic acid. *J. Biol. Chem.* **277**: 38029–38036.
- Zhong, L., Arn-er, E.S., Ljung, J., Aslund, F., Holmgren, A., 1998, Rat and calf thioredoxin reductase are homologous to glutathione reductase with a carboxyl-terminal elongation containing a conserved catalytically active penultimate selenocysteine residue. *J. Biol. Chem.* **273**: 8581–8591.
- Zhou, Y., Kok, K.H., Chun, A.C., Wong, C.M., Wu, H.W., Lin, M.C., Fung, P.C., Kung, H., Jin, D.Y., 2000, Mouse peroxiredoxin V is a thioredoxin peroxidase that inhibits p53-induced apoptosis. *Biochem. Biophys. Res. Commun.* **268**: 921–927.



## CHAPTER 15

# PEROXIREDOXINS IN THE LUNG WITH EMPHASIS ON PEROXIREDOXIN VI

BRUNO SCHREMMER, YEFIM MANEVICH, SHELDON I. FEINSTEIN  
AND ARON B. FISHER

*Institute for Environmental Medicine, University of Pennsylvania, Philadelphia, PA 19104*

**Abstract:** All six mammalian peroxiredoxins are expressed in the lung. Peroxiredoxin (Prx) VI is the isoform expressed at the highest level and its lung expression exceeds that for other organs. The predominant location of Prx VI is the cytosol and acidic organelles of Clara cells of the conducting airways and type II epithelial cells and macrophages in the alveoli. Prx I and VI show developmental induction of transcription at birth. PrxVI shares structural homology with other peroxiredoxins exhibiting a thioredoxin fold and a conserved catalytic Cys residue in the N-terminus of the protein. This enzyme is highly inducible by oxidative stress in both the neonatal and adult lung consistent with a role in antioxidant defense. Prx VI has several properties that distinguish its peroxidase activity from other peroxiredoxins: it can reduce phospholipid hydroperoxides in addition to other organic hydroperoxides and H<sub>2</sub>O<sub>2</sub>; the electron donor that serves to reduce the oxidized peroxidatic cysteine is not thioredoxin but GSH; instead of homodimerization, heterodimerization with  $\pi$ -glutathione S-transferase is required for regeneration of the active enzyme. Prx VI also expresses a phospholipase A<sub>2</sub> activity that is Ca<sup>2+</sup>-independent, maximal at acidic pH, and dependent on a serine-based catalytic triad and nucleophilic elbow at the surface of the protein. Models of altered Prx VI expression at the cellular, organ and whole animal levels have demonstrated that Prx VI functions as an important anti-oxidant enzyme with levels of protection that exceed those ascribed to GSH peroxidase (GPx1). The phospholipase A<sub>2</sub> activity plays an important role in lung surfactant homeostasis and is responsible for the bulk of the degradation of internalized phosphatidylcholine and its resynthesis by the reacylation pathway. Expression of peroxiredoxins is elevated in several lung diseases including lung cancer, mesothelioma and sarcoidosis, although the mechanism for these alterations is not known. The unique properties of Prx VI enable it to play an important role in lung cell function

**Keywords:** Glutathione peroxidase, Glutathione S-transferase, Phospholipase, A<sub>2</sub> Anti-oxidant defense, Surfactant metabolism

## 1. INTRODUCTION

Peroxiredoxins constitute a family of non-seleno peroxidases that is widely distributed throughout all phyla (Leyens *et al.*, 2003). Six peroxiredoxin isoforms (Prx I-VI) have been identified in mammalian tissues (see Table 1). All six share a thioredoxin fold and have near the N-terminus a conserved peroxidatic cysteine that is oxidized to a cysteine sulfenic acid by its nucleophilic attack on hydroperoxides (Rhee *et al.*, 1999). The 2-cys peroxiredoxin proteins (Prx I-V) contain a second conserved cysteine residue that forms either a homodimeric (Prx I-IV) or an intramolecular (Prx V) disulfide bond with the reactive sulfenic acid. Thioredoxin is the electron donor that subsequently reduces the disulfide bridge. Prx VI, the only 1-cys peroxiredoxin present in mammalian tissues, does not possess the resolving cysteine and does not utilize thioredoxin as the electron donor (Manevich and Fisher, 2005). In addition to its peroxidatic activity, Prx VI has phospholipase A<sub>2</sub> (PLA<sub>2</sub>) activity that is necessary for the recycling and synthesis of lung phospholipids (Fisher and Dodia, 1996; Fisher and Dodia, 1997; Kim *et al.*, 1998). Both of these activities of Prx VI have an essential role in lung physiology.

The protein now called Prx VI was first isolated from the ciliary body of the bovine eye and characterized by its N-terminal amino acid sequence (Shichi and Demar, 1990). The protein was demonstrated to have peroxidase activity that was supported by the presence of glutathione (GSH). Subsequently, the cDNA was identified by random cloning and the deduced protein sequence was recognized as a member of the peroxiredoxin family (Nagase *et al.*, 1995). Shortly thereafter, the protein was isolated from rat lung, its PLA<sub>2</sub> activity was identified (Akiba *et al.*, 1998), and its primary molecular sequence was published (Kim *et al.*, 1997). Based on these and subsequent isolations, the protein has had a variety of names prior to reaching a consensus of peroxiredoxin VI (Rhee *et al.*, 2001). These additional names have included non-selenium glutathione peroxidase (Shichi and Demar, 1990), 1-Cys peroxiredoxin (Kang *et al.*, 1998), aiPLA<sub>2</sub> (Kim *et al.*, 1997), LTW4 (Iakoubova *et al.*, 1997), anti-oxidant protein 2 (AOP2) (Iakoubova *et al.*,

Table 1. Properties of peroxiredoxin isoforms

	Prx I-IV	Prx V	Prx VI
Class	2-cys	atypical 2-cys*	1-cys
Thioredoxin fold	yes	yes	yes
Disulfide bond	homodimer	monomer	heterodimer
Reductant	thioredoxin	thioredoxin†	GSH
PLOOH as substrate	no	no	yes
PLA <sub>2</sub> activity	no	no	yes

PLOOH, phospholipid hydroperoxide.

\* A 2-cys Prx that forms an intramolecular disulfide.

† GSH in the presence of glutaredoxin also can reduce a plant homologue of PrxV.

1997; Phelan *et al.*, 1998), Clara cell protein 26 (CC26) (Power and Nicholas, 1999), and p67<sup>phox</sup> binding protein (Leavey *et al.*, 2002); the cDNA has been called ORF6 (Nagase *et al.*, 1995) and the gene has been called KGF-regulated gene (Munz *et al.*, 1997).

## 2. DISTRIBUTION, DEVELOPMENT AND REGULATION OF Prx IN THE LUNG

Regulation of peroxiredoxin expression in the lung can be understood both as developmental regulation and regulation in mature lungs. Developmental regulation has been studied for Prx I, Prx II and Prx VI, while regulation of expression in mature lungs has been studied as a function of exposure to oxidants.

### 2.1. Distribution

Lungs contains all six peroxiredoxin isoforms, as revealed by western blotting for protein (Lehtonen *et al.*, 2004), and RT-PCR and Northern blot for mRNA (Leyens *et al.*, 2003). Compared to other organs, levels of expression of mRNA as determined by normalization to GAPDH mRNA are average or below for Prx I-V (Matsumoto *et al.*, 1999; Lee *et al.*, 2000; Leyens *et al.*, 2003), while at the protein level, Prx I, II and III are present at levels comparable to other organs (Chae *et al.*, 1999). On the other hand, expression of Prx VI is greatly enriched in the lung compared to other organs (Fig. 1A and B). This is seen in both the human (Lehtonen *et al.*, 2004) and rat lung, where Prx VI is enriched at both the mRNA and protein levels (Kim *et al.*, 1998). However, there is controversy for the mouse lung. One laboratory reported that the Prx VI mRNA levels were relatively low in mouse lung with levels in liver substantially higher by both Northern blot (Phelan *et al.*, 2002; Sparling and Phelan, 2003; Simeone and Phelan, 2005) and real-time PCR analyses (Wang *et al.*, 2003; Wang *et al.*, 2004a). A problem with the interpretation of these data is that mRNA was normalized to  $\beta$ -actin and the latter appears to differ substantially between lung and liver. Two other laboratories have reported that Prx VI mRNA levels in mice are highest in the lung, one based on Northern blots (Lee *et al.*, 1999) and the other based on real-time PCR (Mo *et al.*, 2003). In addition, Mo *et al.* (2003) reported that the Prx VI protein level was higher in lung than in liver.

Analysis of the distribution of peroxiredoxins within the human lung (Kinnula *et al.*, 2002) showed high expression of Prx III, Prx V, and VI in bronchial and alveolar epithelial cells (Fig. 1C). Prx I was expressed at a moderate level in the bronchial epithelium, and weakly in the alveolar epithelium, while Prx II and Prx IV were weakly expressed or absent in those cells. All peroxiredoxins were weakly expressed in vascular endothelial cells. All six isoforms were detectable in cells obtained by lung bronchoalveolar lavage (Knoops *et al.*, 1999; Power and Nicholas, 1999; Stripp *et al.*, 2002). In human alveolar

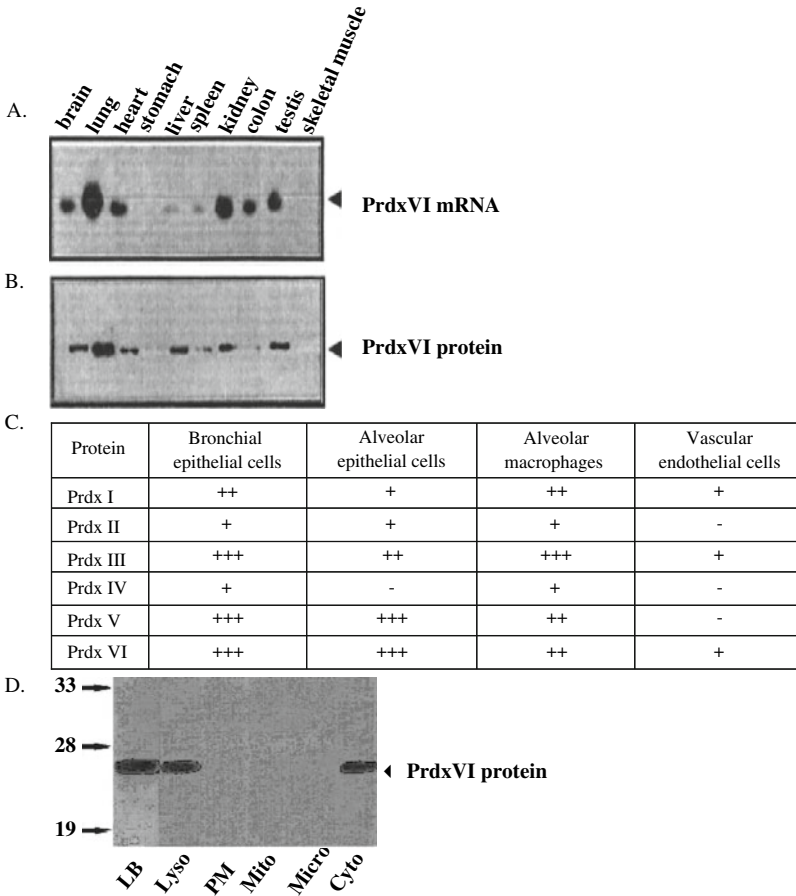

**Figure 1.** Distribution of Prx VI. A. Northern blot using a  $^{32}\text{P}$ -labelled Prx VI probe of RNA isolated from rat organ homogenate. B. Corresponding Western blots of rat organ homogenate probed with an anti-Prx VI antibody. Prx VI is most highly expressed in the lung (A and B, from Fuji *et al.*, 2001). C. Cell specific distribution and expression of peroxiredoxins in the normal human lung analyzed by immunohistochemistry. Intensities range from weak (+) to strong (+++). (Adapted from Kinnula *et al.*, 2002). D. Western blot using an anti Prx VI antibody of subcellular fractions isolated from rat lungs. LB, lamellar bodies; lyso, lysosomes; PM, plasma membranes; mito, mitochondria; micro, microsomes; cyto, cytosol. (Reproduced from Akiba *et al.* 1998)

macrophages, Prx I, III, VI were expressed robustly and Prx II and IV weakly (Fig. 1C). Both Prx V and Prx VI have been identified in cell-free human and rat bronchoalveolar lavage fluid suggesting secretion into the alveolar space (Knoops *et al.*, 1999; Power and Nicholas, 1999; Stripp *et al.*, 2002). However, peroxiredoxins I-IV were not identified by proteomic analysis in cell-free lavage, neither from the normal human lung (Wattiez *et al.*, 1999; Wattiez

*et al.*, 2000) nor from patients with interstitial lung disease (Wattiez *et al.*, 2000).

Subcellular fractionation of the rat lung demonstrated Prx VI in the cytosol, lamellar body, and lysosomal fractions but not in plasma membrane, microsomal, or mitochondrial fractions (Fig. 1 D) (Akiba *et al.*, 1998). It was postulated that the cytosolic expression reflects peroxidase activity, while expression in the acidic organelles (lysosomes, lamellar bodies) supports the phospholipase function (Kim *et al.*, 1997; Fisher *et al.*, 1999).

## 2.2. Developmental Regulation

The expression of peroxiredoxins appears to be tightly controlled in the developing lung. In the rat lung, Prx I increases during late gestation but after birth falls gradually over 2 weeks to adult levels. Prx I mRNA, on the other hand, increases after birth suggesting regulation by both translational and transcriptional mechanisms (Kim *et al.*, 2001). The latter may be part of the “program” to prepare the newborn lung for exposure to the higher oxygen levels associated with air breathing. Similarly, in the fetal baboon, Prx I mRNA levels are constant throughout gestation and abruptly increase by threefold with delivery (Das *et al.*, 2001). Prx II protein concentration is unchanged in the rat perinatal period, but Prx II mRNA increases after birth (Kim *et al.*, 2001), suggesting a regulated efficiency of translation for the mRNA. Fetal rat lungs express relatively small amounts of Prx VI mRNA and protein but show a marked increase immediately after birth, especially in the bronchial epithelium and alveolar cells (Fujii *et al.*, 2001; Kim *et al.*, 2002). The peroxidase and phospholipase activities of Prx VI increase in parallel after birth and reach adult levels at 7–14 postnatal days (Kim *et al.*, 2002).

Prenatal lung maturation and surfactant production are accelerated with the administration of glucocorticoids. Because the phospholipase activity of Prx VI plays an important role in lung surfactant metabolism, the effects of these agents on Prx VI expression was evaluated. Indeed, expression of the protein was induced in the presence of dexamethasone in cultured human and rat lung epithelial cells and as well as *in vivo* in the neonatal rat lung (Kim *et al.*, 2002). There was a modest synergistic effect when cAMP treatment was combined with dexamethasone in human fetal lung epithelial cells.

## 2.3. Regulation of Expression in the Mature Lung

As the peroxiredoxins are peroxidases, oxidant stress has been evaluated as a regulator of their expression. Postnatal exposure to >95% oxygen induced Prx I mRNA and protein levels in the lung by 300% at 72 h. However, the increase in enzyme activity was only 20%, possibly reflecting enzyme inactivation due to oxidation of the protein (Kim *et al.*, 2001). In the adult rat lung and isolated rat type II alveolar cells, mRNA and protein levels of Prx VI increased by 1.5- to 2-fold, respectively, after 50 hours of hyperoxia (Kim *et al.*, 2001). Peroxidase and

phospholipase A<sub>2</sub> activities increased in parallel with Prx VI protein expression (Kim *et al.*, 2003) indicating that inactivation of this protein did not occur with oxidant stress. Oxidative stress induced by H<sub>2</sub>O<sub>2</sub> in type II alveolar epithelial cells resulted in a transient doubling of lipid hydroperoxide content and an increase in levels of Prx I and Prx VI (Tolle *et al.*, 2005). Lipid hydroperoxide content returned to normal by 8 hours as did Prx I and VI protein levels. In contrast to Prx I and VI, Prx II transcripts and protein were unchanged with oxygen exposure suggesting that it is not regulated by oxidant stress (Kim *et al.*, 2001).

### 3. THE PEROXIDASE ACTIVITY OF Prx VI

Peroxiredoxins have been divided into two classes defined as containing either one or two conserved catalytic cysteine residue (Rhee *et al.*, 2001). For the mammalian enzymes, Prx I-IV are classified as 2-cys, PrxV as atypical 2-cys and Prx VI as 1-cys. The first catalytic step in their peroxidase activity is common to all peroxiredoxins. The peroxide undergoes a nucleophilic attack by the activated peroxidatic cysteine to generate a thiolate anion. The geometry of the catalytic site between the 2-Cys Prx and the 1-Cys Prx differ somewhat, but both species give rise to the sulfenic acid intermediate as a result of the initial reaction. The second reaction step, however, is markedly different between the classes of Prx and requires different electron donors to reduce the oxidized cysteine; thioredoxin for 2-Cys Prx (Wood *et al.*, 2003) and glutathione (GSH) for Prx VI (Fig. 2) (Manevich *et al.*, 2004). Recent studies show that a plant homologue of PrxV is also reduced by GSH in association with glutaredoxin (Noguera-Mazon *et al.*, 2006) although relevance of this observation to the mammalian enzyme is not known.

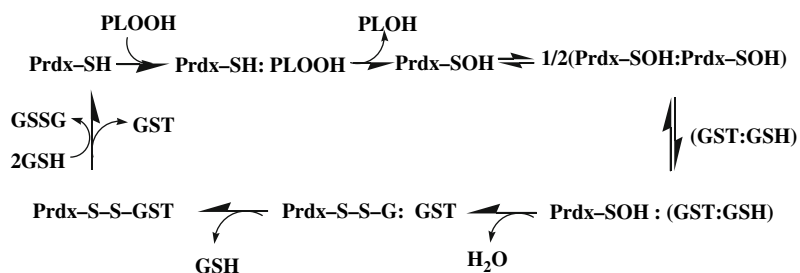
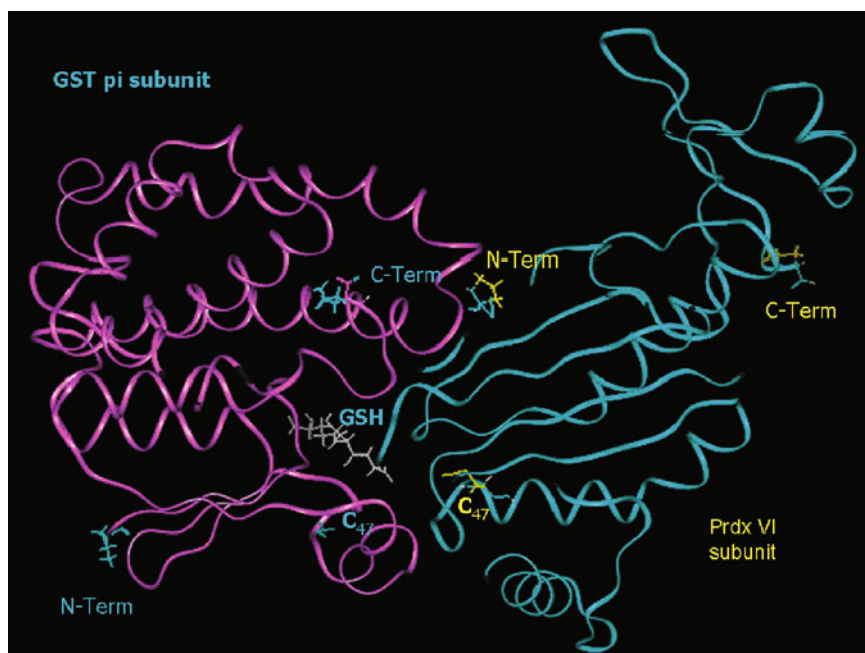

*Figure 2.* Mechanism for reactivation of Prx VI by  $\pi$ GST. The peroxidatic cysteine is oxidized to a sulfenic acid after reaction with hydroperoxides. The oxidized Prx VI heterodimerizes with  $\pi$ GST and then condenses with GSH. This spontaneously proceeds to formation of a disulfide bridge between Prx VI and  $\pi$ GST. Finally, 2 molecules of GSH reduce the bridge back to a sulfhydryl resulting in reactivation of the enzyme. The colons indicate complex formation. (Modified from Manevich *et al.*, 2004)

### 3.1. The Electron Donor for Prx VI

Reduction of the oxidized Cys in typical 2-Cys peroxiredoxins requires homodimerization in a 'head to tail' conformation so that the catalytic and resolving cysteine moieties can form a disulfide that is reduced by interaction with thioredoxin. Prx VI as a 1-Cys enzyme does not possess the resolving Cys and is not reduced by thioredoxin. The identity of the physiological reductant for Prx VI has only recently been resolved. Cyclophilin A was reported to bind as well as reduce oxidized Prx VI (Lee *et al.*, 2001), although a possible mechanism was not provided and this observation has not been confirmed. Small molecular size reductants such as dithiothreitol,  $\beta$ -mercaptoethanol,  $\text{Na}_2\text{S}$ , and dihydrolipoic acid that can diffuse to the relatively inaccessible cysteine-sulfenic residue have been shown to reduce the enzyme but are not candidates for the *in vivo* reductant (Peshenko and Shichi, 2001). Initial observations with Prx VI purified from the bovine ciliary body or the rat olfactory epithelium indicated that the enzyme used GSH as the electron donor (Shichi, 1990; Shichi and Demar, 1990; Peshenko *et al.*, 1996), although this was not consistently borne out by subsequent studies (Kang *et al.*, 1998; Peshenko *et al.*, 1998; Peshenko *et al.*, 2001). However, a carryover contaminant in the isolation of native enzyme from bovine lung reconciled these divergent observations (Manevich *et al.*, 2004). Partial purification of Prx VI from bovine lung homogenate gave an active enzyme preparation capable of reducing hydroperoxides in the presence of GSH; SDS-PAGE separation of the active fraction showed the presence of two similar sized proteins, one Prx VI and the other identified as GSH S-transferase  $\pi$  ( $\pi$ GST). Recombinant Prx VI in the presence of GSH did not reduce hydroperoxides but addition of GSH-loaded  $\pi$ GST resulted in sustained GSH peroxidase activity. Liposomal delivery of oxidized Prx VI (which is inactive) to H441 cells, a line that does not express this enzyme but expresses  $\pi$ GST, increased cellular peroxidase activity; on the other hand, delivery of both Prx VI and  $\pi$ GST to MCF7 cells which lack  $\pi$ GST increased their peroxidase activity, while either enzyme delivered alone was ineffective (Manevich *et al.*, 2004). These results demonstrate that GSH acts as the electron donor for reduction of Prx VI in the presence of  $\pi$ GST. Thus, GSH appears to be the physiological reductant, but the oxidized protein requires interaction with the enzyme  $\pi$ GST in order to generate an active complex.

To function in the catalytic cycle, Prx VI and  $\pi$ GST form a stable heterodimer, analogous to the homodimer formed by 2-Cys peroxiredoxins (Fig. 3). Formation of the  $\pi$ GST-Prx VI heterodimer is favored by the high (millimolar) concentration of GSH that is present in cytosol. Complex formation is substantially reduced in the absence of GSH and is not supported by oxidized glutathione. The effect of GSH is independent of its reducing power as S-methyl glutathione, a non-reducing analogue, could effectively generate the heterodimer but did not support the peroxidase reaction (Ralat *et al.*, 2006). This suggests that GSH acts as a bridge between the two proteins. Indeed, mutation of Tyr 7 of  $\pi$ GST, a residue key to the binding of GSH by  $\pi$ GST, disrupted formation of the heterodimeric complex, as did mutation of the  $\pi$ GST Cys 47 which directly binds GSH (Cys at the 47 position in both proteins is a coincidence). Interaction of GST with Prx VI



*Figure 3.* In silico predicted structure of the Prx VI- $\pi$ GST heterodimer using Insight II and ZDOCKpro programs.  $\pi$ GST interfaces with Prx VI at the site occupied, in the Prx VI homodimer, by the carboxy-domain of the opposite monomer, a domain unique to this isoform. In this structure, the reactive cysteines of the two enzymes remain too far apart to form a disulfide bridge. GSH bound to its G-site is at the interface of the two enzymes. Cyan, Prx VI subunit; magenta, GST  $\pi$  subunit. (Reproduced from Ralat *et al.*, 2006) (See Plate 22)

is isoform-specific; no significant interaction was noted with  $\alpha$ GST, while  $\mu$ GST formed small amounts of heterodimer that had only 20% of the peroxidase activity compared to  $\pi$ GST. Structural similarities between the  $\mu$ GST and  $\pi$ GST have been reported (Sinning *et al.*, 1993), an observation that supports specificity of the  $\pi$ GST-Prx VI interaction.

For 2-Cys peroxiredoxins, the reaction of a sulfenic (catalytic) cysteine and reduced (resolving) cysteine occurs spontaneously to yield a disulfide bridge and water (Poole *et al.*, 2004). However, this does not occur immediately between the sulfenic peroxidatic cysteine 47 of Prx VI and reduced Cys 47 of  $\pi$ GST, as the two residues are predicted to be 9 Å apart by molecular modeling (Ralat *et al.*, 2006). Formation of the complex of Prx VI with  $\pi$ GST likely distorts the tertiary structure of both enzymes and could allow access to the sulfenic peroxidatic cysteine by GSH that has been activated by binding to the G site of  $\pi$ GST (Fig. 3). Normally, access to the oxidized Cys of Prx VI is limited by its location in a deep cleft (see below). The glutathionylated Prx VI intermediate could be detected by  $^{35}$ S-glutathione labeling (Manevich *et al.*, 2004) and by immunoblotting with an



anti-glutathionylated protein antibody after a short (one-minute) incubation of Prx VI with GSH-loaded  $\pi$ GST (Ralat *et al.*, 2006).

Following heterodimer formation, the next step in the reduction of the catalytic Cys requires displacement of GSH and formation of an inter-subunit  $\pi$ GST-Prx VI disulfide bridge similar to that for 2-Cys peroxiredoxins (Fig. 3). Formation of this intermediate was confirmed by non-reducing SDS-PAGE analysis and was coupled with a decrease in the content of reduced cysteine by 2 moles per mole of the complex (Ralat *et al.*, 2006). Attack of this disulfide by GSH results in recovery of the sulfhydryls of the peroxidatic cysteine of Prx VI and Cys47 of  $\pi$ GST, and in dissociation of the complex (Fig. 2).

Heterodimerization likely induces significant structural changes in  $\pi$ GST, as suggested by changes in the  $K_M$  and  $V_{max}$  of the  $\pi$ GST-Prx VI heterodimer for GSH compared to that of the  $\pi$ GST homodimer (3.5 times greater and three-fold lower, respectively) indicating that the association of the two proteins partially inhibits catalysis by  $\pi$ GST (Manevich *et al.*, 2004; Ralat *et al.*, 2006). In contrast, peroxidase activity of Prx VI was unchanged because only oxidized (inactive) Prx VI forms a heterodimer, while reduced (active) enzyme dissociates from it.

Prx VI can be hyperoxidized to the cysteine sulfinic or sulfonic acid forms, and a possible mechanism for reduction of the Cys from this state has not been determined. Unlike its role with Prx I-IV, sulfiredoxin does not reduce the hyperoxidized state of the peroxidatic cysteine in Prx VI (Chang *et al.*, 2004).

### 3.2. Substrate Specificity of Prx VI

Prx VI is able to reduce a broad range of substrates, including  $H_2O_2$ , small organic hydroperoxides such as *tert*-butyl hydroperoxide and cumene hydroperoxide, fatty acid hydroperoxides and phospholipid hydroperoxides (Fisher *et al.*, 1999b). The hydroperoxides of linolenic and arachidonic acids are effectively and equally reduced to the corresponding alcohols, both as free fatty acid hydroperoxides or when they are incorporated at the *sn*-2 position of phospholipids as fatty acyl hydroperoxides (Fisher *et al.*, 1999b) (Table 2). The similar kinetic constants for these various substrates are evidence for the robust activity of Prx VI towards phospholipid hydroperoxides. Reduction of phospholipid hydroperoxide by recombinant Prx VI that was activated with GSH-loaded  $\pi$ GST was approximately  $5 \mu\text{mol min}^{-1} \text{mg protein}^{-1}$  (Manevich *et al.*, 2004; Ralat *et al.*, 2006). This represents an increase over the result for maximum activity shown in Table 2, which was obtained prior to the recognition of the important role of  $\pi$ GST. The  $K_m$  for Prx VI peroxidase activity was between 120–180  $\mu\text{M}$  for  $H_2O_2$  and all hydroperoxides (Table 2) and was similar for the Prx VI -  $\pi$ GST complex (Ralat *et al.*, 2006).

The ability of Prx VI to reduce phospholipid hydroperoxides appears to be unique for lung peroxidases and this activity is not exhibited by cytosolic GSH peroxidase (GPx1) (Michiels *et al.*, 1994). GPx4, the so-called phospholipid hydroperoxide glutathione peroxidase, can reduce phospholipid hydroperoxides *in vitro* (Ursini *et al.*, 1995) but has limited or no activity in the lung (Wang *et al.*, 2004;

Table 2. Activity and kinetic constants for recombinant human Prx VI

Substrate	GPx Activity, $\mu\text{mol}/\text{min}/\text{mg}$ prot	App. $V_{\text{max}}$ , $\text{mmol}/\text{min}/\text{mg}$ prot	App. $K_m$ , $\mu\text{M}$	$k_1$ , $\text{M}^{-1}\text{sec}^{-1}$	$k_2$ , $\text{M}^{-1}\text{sec}^{-1}$
$\text{H}_2\text{O}_2$	$1.85 \pm 0.03$	1.8	180	$3.0 \times 10^6$	$1.5 \times 10^6$
Linolenoyl hydroperoxide	$1.4 \pm 0.02$	1.4	141	$2.8 \times 10^6$	$2.2 \times 10^6$
Arachidonoyl hydroperoxide	$1.36 \pm 0.03$	1.4	135	$3.0 \times 10^6$	$1.2 \times 10^6$
PLPC Hydroperoxide	$1.47 \pm 0.04$	1.5	120	$5.3 \times 10^6$	$1.8 \times 10^6$
PAPC hydroperoxide	$1.67 \pm 0.03$	1.6	129	$3.8 \times 10^6$	$1.3 \times 10^6$

Values represent mean  $\pm$  SE for n=3 separate experiments. Apparent  $V_{\text{max}}$  and  $K_m$  were calculated from activity measured at 0.36 mM GSH. P, palmitoyl; L, linolenoyl; A, arachidonoyl; PC, phosphatidylcholine. Data from Fisher *et al.*, 1999.

Fukuhara and Kageyama, 2005). This can be deduced from assays with mouse lung homogenate where phospholipid hydroperoxide reductase activity was essentially abolished by knock-out of Prx VI (Table 3). In contrast to the result with phospholipid hydroperoxide, lung homogenate shows significantly greater activity with  $\text{H}_2\text{O}_2$  as substrate and activity is not affected by knock-out of Prx VI reflecting the presence of catalase, GPx1, and other proteins for  $\text{H}_2\text{O}_2$  reduction (Wang *et al.*, 2004b).

### 3.3. Structural Determinants for Enzymatic Activity

Structural determinants of the peroxidase activity of peroxiredoxins have been extrapolated from the crystal structure of the oxidized and disulfide-bridged intermediate of the Prx II homodimer (Hirotsu *et al.*, 1999), from the structure of the completely reduced form of Prx V (Declercq *et al.*, 2001; Evrard *et al.*, 2004), and from the Prx VI crystal structure that was obtained with a stable sulfenic cysteine

Table 3. Hydroperoxide reductase activity of mouse lung homogenate with  $\text{H}_2\text{O}_2$  and phospholipid hydroperoxide substrates

	$\text{H}_2\text{O}_2$ $\text{nmol}/\text{min}/\text{mg}$	PLPCOOH $\text{nmol}/\text{min}/\text{mg}$
Wild type mouse	$53.1 \pm 3.1$	$44.4 \pm 0.6$
Prx VI null mouse	$46.1 \pm 1.8$	$1.2 \pm 0.06$

Values are mean  $\pm$  SE for n=3. Substrate was present at 80  $\mu\text{M}$  and GSH at 0.36 mM. PLPCOOH, 1-palmitoyl, 2-linolenoyl sn-3 glycerophosphorylcholine prepared with soybean lipoxygenase (data from Wang *et al.*, 2004b).

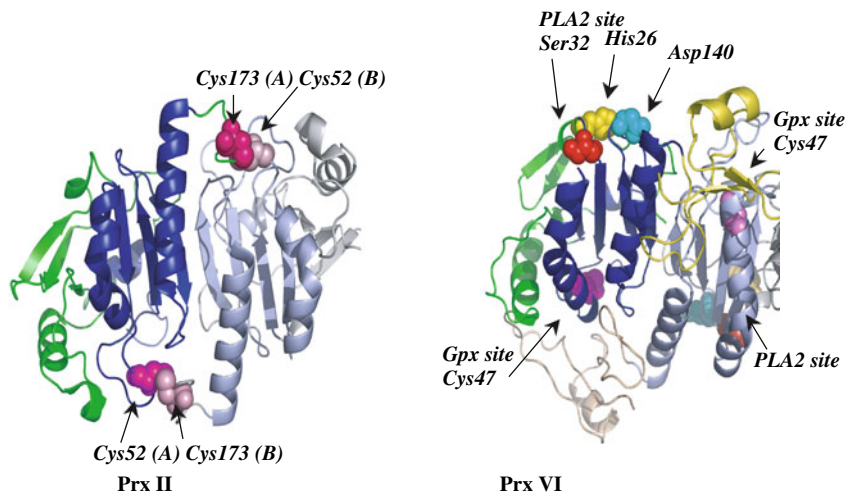

**Figure 4.** Crystal structure of rat Prx II (HBP23) and human Prx VI (ORF6) homodimers (Protein Data Bank accession nos. 1QQ2 and 1PRX, respectively). For Prx VI, the non-conserved Cys 91, was mutated to a serine prior to crystallization and the catalytic cysteine was oxidized (Choi *et al.*, 1998). Four  $\beta$ -strands and three  $\alpha$ -helices form the thioredoxin fold. The peroxidatic cysteine is on the surface of Prx II (Cys52), while it is more deeply situated in the protein globule of Prx VI (Cys 47). The catalytic and resolving cysteines of the opposing chains of Prx II are in close proximity after partial melting of the N-terminal portion of the alpha helix. Prx VI, as a 1 cys peroxiredoxin, does not demonstrate a resolving cys and the homodimer is not a physiological construct. In Prx VI, an additional 40 amino acid carboxy-terminus domain (light yellow) partly overlies the catalytic cysteine. The residues Ser32-His28-Asp140 are within 10 Å of one another and form the proposed PLA<sub>2</sub> catalytic triad at the surface of Prx VI. The  $\alpha$ 5 helix that spans the phospholipase site and the glutathione peroxidase site is lined with hydrophobic residues, favoring the binding of phospholipids. Blue, thioredoxin fold; green, protein N-terminus; other colors indicate amino acid residues as indicated in the figure. Images were constructed with PyMOL Molecular Graphics System, DeLano Scientific, San Carlos, CA, USA. (Prx VI image modified from Manevich *et al.*, 2005) (See Plate 23)

intermediate (Fig. 4) (Choi *et al.*, 1998). All peroxiredoxins have a “thioredoxin fold” consisting of a central motif of four  $\beta$ -sheets flanked by three  $\alpha$ -helices (Wood *et al.*, 2003) and two insertions: a small N terminal segment and an  $\alpha/\beta$  segment inserted between  $\alpha$ 4 and  $\beta$ 4 of the “thioredoxin fold”. Prx VI possesses an additional C-terminal domain, comprised of 49 amino acids, that is unique to this isoform. The function of the Prx VI C-terminal domain is unknown, but from its topography it may partake in the formation of the  $\pi$ GST-Prx VI heterodimer (Ralat *et al.*, 2006).

The location of the peroxidatic cysteine of Prx VI is conserved similarly to other proteins expressing the “thioredoxin fold”. It is positioned in the N-terminal portion of the catalytic  $\alpha$ 2 helix and buried inside of the protein globule. By analogy with the Prx V structure (Declercq *et al.*, 2001), the Thr44 and the carbonyl and the amide groups of the vicinal peptide backbone in the reduced (active) form of Prx VI form a hydrogen bond network with Cys47, while Arg132 stabilizes the Cys47 thiolate

anion (Hofmann *et al.*, 2002). Oxidation of Cys47 to sulfenic acid results in closer proximity and hydrogen bonding with His39 as well as with the guanidinium group of Arg132 to stabilize this otherwise labile intermediate (Choi *et al.*, 1998). By this structural rearrangement, the oxidized sulfur atom becomes relatively inaccessible to solvent and other molecules, in particular a second peroxide molecule, an important feature to prevent irreversible overoxidation of the peroxidatic cysteine (Wood *et al.*, 2003).

The catalytic cycle of Prx VI (and possibly Prx V) is unique in producing a glutathionylated intermediate (Fig. 2). However, the crystal structure predicts that GSH is too bulky and hydrophilic to approach the sulfenic acid (Fig. 4). In the disulfide bridged intermediate of the Prx V monomer, the loop-helix bearing the peroxidatic cysteine sulfenic acid melts and moves outward to bridge with the resolving cysteine (Hirotsu *et al.*, 1999; Evrard *et al.*, 2004). In Prx VI, the position of the peroxidatic cysteine in the N-terminal portion of the  $\alpha 2$  helix presumably allows local unfolding of this helix to reach out towards the Cys47 of  $\pi$ GST. *In silico*,  $\pi$ GST could be docked to the Prx VI monomer to occupy the position of the C-terminal domain of the other Prx VI monomer in the homodimeric configuration (Ralat *et al.*, 2006) (Fig. 3). In this predicted structure, the  $\pi$ GST G-site binds and activates GSH at the heterodimer interface. However, GSH is still  $\sim 15 \text{ \AA}$  and the resolving Cys47 of  $\pi$ GST is  $\sim 9 \text{ \AA}$  distant from the peroxidatic Cys47 in Prx VI. Local unfolding of the peroxidatic loop- $\alpha 2$  helix, as observed in the Prx V structure, or structural changes of  $\pi$ GST that likely occur on heterodimerization could bridge this distance. This hypothesis is consistent with changes in the transferase activity of  $\pi$ GST upon interaction with oxidized Prx VI.

The catalytic activity of Prx VI towards phospholipid hydroperoxide requires the specific binding of this substrate to position its hydroperoxy- group in the vicinity of the peroxidatic Cys47. Based on our preliminary studies, it appears that the polar head of the phospholipid hydroperoxide substrate binds to the surface of the protein in the vicinity of the hydrolytic catalytic triad Ser32-His26-Asp140 (Fig. 4). This positioning is determined by the "thioredoxin fold". The peroxidized acyl chain then can gain access to the cavity containing cys47. We have shown (unpublished) that site-specific mutation of Ser32 and His26 abolished phospholipid hydroperoxide binding to Prx VI. Mutation of Ser32 results in dramatic changes of protein folding i.e. elimination of the "thioredoxin fold" and generation of a complete  $\alpha$ -helical structure. The His26 mutation had only minimal effect on protein folding, but both the His26 and Ser32 mutations abolished Prx VI-mediated reduction of phospholipid hydroperoxide (Chen *et al.*, 2000).

#### 4. ANTIOXIDANT FUNCTION OF Prx VI IN THE LUNG

The lung, because of its physiological role in gas exchange, is uniquely susceptible to oxidant stress. Inhaled oxidants include oxygen at high partial pressure administered for therapeutic purposes, ozone as an environmental pollutant, paraquat as a toxic herbicide, and cigarette smoke as a self-inflicted insult to the lung.

Furthermore, a wide variety of redox-active drugs or toxins either inhaled or administered systemically by ingestion or injection are delivered to the lung in relatively high concentration by the high rate of pulmonary perfusion. These oxidants and redox-active agents give rise to the superoxide anion which in turn generates  $\text{H}_2\text{O}_2$  (Fig. 5). The latter functions as a mild oxidant and as the key precursor for the highly toxic hydroxyl radical ( $\cdot\text{OH}$ ). Since there are no specific enzymatic removal pathways for  $\cdot\text{OH}$ , removal of  $\text{H}_2\text{O}_2$  is of major importance in protection against oxidative stress.

The lungs, like most organs, contain several enzymes that have been shown *in vitro* to efficiently scavenge  $\text{H}_2\text{O}_2$  (Fig. 5). These include catalase, glutathione peroxidases (GPx), and peroxiredoxins. Catalase is confined to peroxisomes and for the most part is thought to play a relatively modest role in lung antioxidant defense. GPx1 has been considered as the primary enzyme for  $\text{H}_2\text{O}_2$  removal. However, knockout of GPx1 in mice has resulted in relatively little change in the resistance to 100% oxygen (Ho *et al.*, 1997). By contrast, knock-out of Prx VI results in marked effects on the extent of lung injury with oxidant exposure, indicating that Prx VI compared to GPx1 provides significantly greater anti-oxidant protection to the lung (Wang *et al.*, 2004) (Fig. 6).

What is the basis for this demonstrably more effective role played by Prx VI compared to GPx1? Both enzymes use GSH as the physiological reductant to scavenge  $\text{H}_2\text{O}_2$ . Knock-out of GPx1 decreased lung GSH peroxidase activity with  $\text{H}_2\text{O}_2$  as substrate by 94% (Ho *et al.*, 1997), while knock-out of Prx VI had a relatively slight effect (Table 3). Further, the rate constant for GSH-dependent  $\text{H}_2\text{O}_2$  peroxidase activity is approximately 10-fold greater for GPx1 compared to Prx VI (Ding *et al.*, 1998). Thus, it seems unlikely that scavenging of  $\text{H}_2\text{O}_2$  represents the

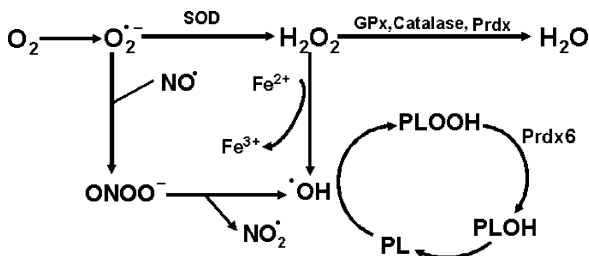

*Figure 5.* Production of reactive oxygen (ROS) and nitrogen (RNS) species. In cellular systems, the initial step is the one electron reduction of molecular oxygen to produce the superoxide anion ( $\text{O}_2^{\cdot-}$ ).  $\text{H}_2\text{O}_2$  is produced by reduction of  $\text{O}_2^{\cdot-}$  and further reduced to  $\text{H}_2\text{O}$  by catalase, GSH peroxidases, and theoredoxins. In the presence of ferrous ion,  $\text{H}_2\text{O}_2$  can be converted to a hydroxyl radical ( $\cdot\text{OH}$ ) which can react directly with unsaturated fatty acids to produce hydroperoxy lipids.  $\cdot\text{OH}$  also can be generated following the decomposition of  $\text{ONOO}^-$  produced by reaction of  $\text{NO}$  with  $\text{O}_2^{\cdot-}$ . In the cell, peroxidized phospholipids signify membrane damage then can lead to cell death. Prx VI is the only enzyme in lung cells that can effectively and directly reduce these phospholipid hydroperoxides. (Reproduced from Manevich *et al.*, 2005)

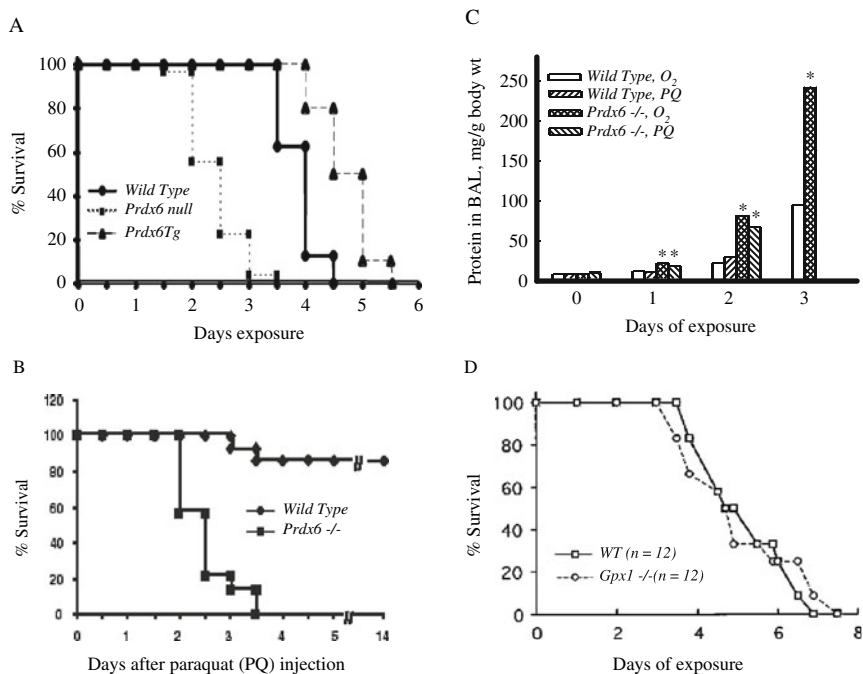

**Figure 6.** Survival and lung injury with exposure to 100% oxygen or administration of paraquat. **A.** Survival in 100% oxygen of age-matched Prx VI overexpressing transgenic (Tg) mice ( $n = 10$ ), Prx VI null mice ( $n = 27$ ), and wild-type C57Bl/6 mice ( $n = 24$ ). Survival times of the both transgenic and knockout mice were significantly different from the control wild type animals. (Adapted from Wang *et al.*, 2004b; 2006b). **B.** Survival of age-matched wild type and Prx VI null mice following intraperitoneal injection of paraquat, 30  $\mu\text{g}$  per g body weight. Survival is significantly decreased in Prx VI null ( $n = 14$ ) compared to wild type ( $n = 14$ ) mice. (From Wang *et al.*, 2006). **C.** Protein content of the bronchoalveolar lavage fluid (BALF) in wild type and Prx VI knock-out mice at 72 h of exposure to 100% O<sub>2</sub>. Increased protein indicates protein efflux from the plasma due to increased lung permeability associated with alveolar injury, \* $P < 0.05$  vs. wild type. (Adapted from Wang *et al.*, 2004c; 2006a). **D.** Survival of age-matched wild-type and homozygous GSH peroxidase 1 (GPx1) knockout mice in 100% O<sub>2</sub>. No statistically significant difference in survival was observed. (Reproduced from Ho *et al.*, 1997)

essential function of Prx VI in the lung and equally unlikely that this activity is responsible for its greater role in antioxidant defense.

As indicated above, generation of  $\bullet\text{OH}$  represents a major threat during oxidant exposure. This radical reacts indiscriminately with organic compounds and a major mechanism of cellular toxicity is its interaction with lipids containing unsaturated fatty acids leading to a chain reaction of lipid peroxidation. Indeed, peroxidation of cell membrane phospholipids is a major threat to cellular integrity and an important cause of oxidant injury. The presence of vitamin E can block the chain reaction of lipid peroxidation but does not restore oxidized phospholipids to their native reduced state. It has been demonstrated repeatedly that GPx1, while efficiently

reducing  $H_2O_2$  and fatty acid hydroperoxides, is unable to reduce phospholipid hydroperoxides (Grossmann and Wendel, 1983; Sevanian *et al.*, 1983; Michiels *et al.*, 1994; Flohé and Brigelius-Flohé, 2001). The traditional view has been that repair of oxidized phospholipids requires excision of the peroxidized fatty acid through activity of a PLA<sub>2</sub>, subsequent reduction of the fatty acid hydroperoxide by GPx1, and then reacylation by an acyl transferase, altogether a relatively slow process. GPx4, called phospholipid hydroperoxide glutathione peroxidase, can directly reduce phospholipid hydroperoxides using GSH and this reaction has been estimated at 4 orders of magnitude more efficient than the classical mechanism involving phospholipid deacylation (Antunes *et al.*, 2002; Zhao *et al.*, 2003). However, the concentration and activity of GPx4 are relatively low in the lung (Wang *et al.*, 2004b; Fukuhara and Kageyama, 2005). Prx VI also can directly reduce phospholipid hydroperoxide using GSH as the electron donor (Fisher *et al.*, 1999b). To emphasize the primacy of Prx VI in this reaction in the lung, knock-out of the enzyme resulted in 96% decrease in ability of the lung homogenate to reduce phospholipid hydroperoxides, while reduction of  $H_2O_2$  was relatively unchanged (Wang *et al.*, 2004b) (Table 3). The ability of Prx VI to reduce phospholipid hydroperoxides and thereby restore membrane integrity could account for its role as an important lung antioxidant enzyme (Manevich *et al.*, 2002).

#### 4.1. Cellular Models of Altered Prx VI Expression

The effect of altered Prx VI expression on the response to oxidative stress has been studied in a variety of isolated lung cell models. These include H441 cells, a human lung epithelial cell line that normally expresses Prx VI at low levels, L2 cells, a rat lung epithelial cell line that shows significantly higher levels of Prx VI expression, and lung fibroblasts. Knock-down of Prx VI expression in L2 cells by about 60% using antisense oligonucleotides resulted in poor growth and a marked increase in cellular apoptosis (Pak *et al.*, 2002). Analysis of these cells showed a significant increase in lipid peroxidation products, indicating increased susceptibility to oxidative stress under standard cell culture conditions. Cells could be rescued from these effects by infection with a Prx VI adenoviral expression vector (Pak *et al.*, 2002).

Stable overexpression of Prx VI in H441 cells resulted in relative resistance to the toxic effects of a hydroxyl radical generating system. Compared to wild type, the overexpressing cells had smaller increases in content of phospholipid hydroperoxides on oxidant exposure and a decreased rate of cell death (Manevich *et al.*, 2002). Overexpression of Prx VI in immortalized human lung fibroblasts demonstrated protection against cytotoxic doses of exogenous hydroperoxides and ultraviolet B radiation (Dierick *et al.*, 2003). Since scavenging of  $\bullet OH$  is not a specific function of Prx VI, protection in these experiments is compatible with the ability of the enzyme to reduce phospholipid hydroperoxides formed during oxidative stress.

## 4.2. Animal Models of Altered Prx VI Expression

The effect of altered Prx VI expression also has been studied in mouse models. Prx VI knock-out mice have been developed independently by two laboratories using different gene-targeting constructs (Mo *et al.*, 2003; Wang *et al.*, 2003). For both strains, mice developed normally, were fertile, and showed no phenotypic abnormalities in the unstressed condition. Expression of other antioxidant enzymes including catalase, MnSOD, CuZn SOD and GPx1 was similar in lungs from Prx VI null and wild type mice (Wang *et al.*, 2004b). Exposure to 100% oxygen breathing and systemic paraquat administration were used as models of lung oxidant injury (Wang *et al.*, 2004b; Wang *et al.*, 2006a). Knockout of Prx VI resulted in a marked increase in sensitivity to oxidant stress (Fig. 6). With 100% oxygen exposure, the time to 50% mortality was 42.5 hours for Prx VI null mice as compared to 88.5 hours for wild-type (Fig. 6A). With exposure to paraquat (30 µg per kg body weight), all of the Prx VI mice had died by 4 days, while 86% of the wild type mice had survived (Wang *et al.*, 2006b) (Fig. 6B). Examination of lungs by histology, lung wt to dry weight ratio, content of protein in the bronchoalveolar lavage fluid (Fig. 6C), number and distribution of inflammatory cells in the bronchoalveolar lavage fluid, and protein carbonyls in the lung tissue provided evidence for a greater degree of lung damage in the Prx VI null mice (Wang *et al.*, 2004b; Wang *et al.*, 2006a). An increase in the lung content of thiobarbituric acid reactive substances (TBARS) gave evidence for increased lipid peroxidation in the absence of Prx VI (Wang *et al.*, 2004b; Wang *et al.*, 2006a). This latter result is compatible with the ability of Prx VI to reduce phospholipid hydroperoxides.

Mice over-expressing Prx VI in the lung also have been evaluated for response to oxidant stress. Transient overexpression by adenovirus-mediated gene transfer of Prx VI resulted in a peak 2-fold increase in lung expression of Prx VI (Wang *et al.*, 2004c). Transgenic mice overexpressing Prx VI driven by the endogenous promoter showed approximately 3-fold increase in Prx VI expression (Wang *et al.*, 2006b) In both of these models, mortality during exposure to 100% oxygen was modestly but significantly reduced with a corresponding lessening of the alterations associated with lung injury.

Protection against lung oxidant injury by overexpression and the converse, the marked increase in lung injury associated with decreased expression, provide evidence for the importance of Prx VI in lung antioxidant defense. Indeed, injury associated with Prx VI knock-out appears to be greater than that associated with manipulation of any of the various other antioxidant enzymes or tissue antioxidants that have been previously reported for these well studied animal models. For example, knock-out of GPx1 resulted in essentially no change in the response to 100% oxygen (Ho *et al.*, 1997) (Fig. 6D). We conclude from these results that Prx VI is the major GSH-dependent enzyme that functions in lung anti-oxidant defense.



## 5. PHOSPHOLIPASE A<sub>2</sub> ACTIVITY OF Prx VI

The PLA<sub>2</sub> activity of Prx VI was discovered through a study of lung phospholipid metabolism. The tetrahedral mimic, 1-hexadecyl-3-trifluoroethylglycero-sn-2-phosphomethanol (MJ33), a transition state analogue PLA<sub>2</sub> inhibitor, was found to markedly inhibit lung phospholipid metabolism (Fisher and Dodia, 1997). The MJ33-inhibited activity in rat lung showed calcium-independence and maximal activity at pH 4.0 leading to the appellation aiPLA<sub>2</sub>. By using MJ33 as a probe, the protein expressing aiPLA<sub>2</sub> activity was isolated (Akiba *et al.*, 1998) and the corresponding cDNA was subsequently identified (Kim, *et al.*, 1997). Expression of the cDNA in both acellular and cellular systems demonstrated PLA<sub>2</sub> activity for the encoded protein. Because Prx VI expresses two disparate enzymatic activities, it has been called a “moonlighting” protein (Chen *et al.*, 2000).

### 5.1. Overview of Surfactant Physiology

Pulmonary surfactant is a complex mixture of lipids and proteins that is secreted into the extracellular (alveolar) airspace of the lung and functions to maintain a suitably low surface tension at the air-liquid interface in order to promote lung stability (Batenburg and Haagsman, 1998; Whitsett and Weaver, 2002). Adequate surfactant is necessary for lungs to function in their role as the organ of gas exchange. Phospholipids account for more than 80% of the surfactant by mass. Dipalmitoylphosphatidylcholine (DPPC) is the major surface-active component and has been the focus of most studies of lung phospholipid metabolism. DPPC as a surfactant component has a complex and well regulated metabolic fate. It is synthesized in the alveolar epithelial cells by either a *de novo* pathway involving acylation of glycerol (or dihydroxyacetone) phosphate or a deacylation-reacylation pathway which involves the sequential activity of a PLA<sub>2</sub> and an acyl transferase. The subcellular site for *de novo* synthesis is the endoplasmic reticulum. The site for the deacylation-reacylation pathway is unclear but current evidence suggests that an acidic organelle such as the lysosome is involved in the initial step (Fisher and Dodia, 1997). Newly synthesized surfactant is stored in the lung lamellar bodies, secreted by exocytosis, and, following its extracellular function, is endocytosed and targeted either for resecretion or degradation. The degraded products, especially those containing the essential choline moiety, are retained in the cell and reutilized.

### 5.2. Properties of Prx VI as a Phospholipase A<sub>2</sub>

PLA<sub>2</sub> comprises a broad family of enzymes that hydrolyze the sn-2 acyl or alkyl moiety of phospholipids (Six and Dennis, 2000). These enzymes were first characterized as components of snake and other venoms and then shown to be present in mammalian pancreatic secretions, inflammatory exudates, and the cytosol of essentially all cells. The secreted enzymes require Ca<sup>2+</sup> at mM concentrations for activity, while the intracellular enzymes can function at much lower (intracellular)

Ca<sup>2+</sup> concentrations. Prx VI as an intracellular PLA<sub>2</sub> is Ca<sup>2+</sup>-independent (Kim, *et al.*, 1997). A distinguishing characteristic of Prx VI is maximal activity at pH 4 (Akiba *et al.*, 1998), in contrast to other members of the PLA<sub>2</sub> family that show maximal activity in the mildly alkaline range. Thus, the PLA<sub>2</sub> activity of Prx VI has a pH profile suggesting a lysosomal localization, consistent with the results for lung subcellular fractionation (Akiba *et al.*, 1998) (Fig. 1). Prx VI also is present in lung lamellar bodies, an acidic organelle that functions in surfactant storage and secretion and appears to be derived from lysosomes. Both lysosomes and lamellar bodies isolated from rat lungs show significant aiPLA<sub>2</sub> activity (Fisher and Dodia, 1996; Fisher and Dodia, 2001).

The aiPLA<sub>2</sub> activity of native and recombinant Prx VI is 50–100 nmol/min/mg protein with apparent K<sub>m</sub> ~ 350 μM for phosphatidylcholine as substrate (Kim *et al.*, 1997; Akiba *et al.*, 1998; Chen *et al.*, 2000). Activity is greatest with phosphatidylcholine substrate and is significantly decreased with phosphatidylethanolamine, phosphatidylglycerol, or phosphatidylserine (Kim *et al.*, 1997; Akiba *et al.*, 1998). The enzyme does not discriminate between different fatty acyl moieties at the sn-2 position, although activity was significantly decreased with the alkyl ether phospholipid. Hydrolysis of peroxidized phospholipid was similar to the native compound. Prx VI does not have phospholipase A<sub>1</sub> or lysophospholipase activity (Kim *et al.*, 1997; Akiba *et al.*, 1998).

### 5.3. Structural Determinants for Phospholipase Activity

The catalytic residue required for the acyl hydrolase activity of different PLA<sub>2</sub>s may be either a histidine or a serine (Six and Dennis, 2000). Primary sequence analysis of Prx VI showed the existence of a hydrolase motif Ser-His-Asp. This catalytic triad is present in various proteases and lipases including PLA<sub>2</sub> enzymes of the so-called classes VI, VII, and VIII. These three proteins belong to different groups based on structure/function: ankyrin repeats, α/β hydrolase, or small G protein, respectively, while Prx VI is a member of the thioredoxin fold superfamily (see above). Two Gly residues flank the catalytic Ser, GX SXG, a configuration found in the α/β hydrolase fold (Ollis *et al.*, 1992), that partakes in the oxyanion hole, and serves to stabilize the tetrahedral intermediate product. It also forces the Ser 32 to adopt a strained ε-conformation and form a ‘nucleophile elbow’, also termed the “lipase” motif (Brenner, 1988). Both the catalytic triad and the “nucleophilic” elbow are found appropriately positioned in the crystal structure of Prx VI (Choi *et al.*, 1998). All three residues of the catalytic triad are in sufficient proximity to form bridges of H-bonds and are located either at the edges of β-sheets (however at the N-terminus of the sheet rather than the C part of the loop as in the α/β hydrolase fold) or contained in loops (Manevich and Fisher, 2005) (Fig. 4). However, the Ser hydroxyl moiety is directed away from the His and unable to form the linear H-bonds characteristic of the triad. To do so it would need to be in the ε-conformation (Brenner, 1988). Binding of the tetrahedral substrate analogue MJ33 to Prx VI caused changes in the circular dichroism spectrum (Manevich *et al.*,

2005) that could reflect structural changes necessary to align the triad, as has been observed for other lipases when binding to fatty acids (Nardini and Dijkstra, 1999). The putative binding groove formed by the  $\alpha$ -helix, which spans the peroxidase catalytic site and the phospholipase site, is lined with hydrophobic residues, so that binding of lipids is likely to be energetically very favorable as described above for binding of phospholipid hydroperoxides. The serine residue of the Prx VI catalytic triad Ser32-His26-Asp140 was shown by site directed mutagenesis to be critical for its phospholipase activity but its absence did not affect the  $H_2O_2$  peroxidase activity (Chen *et al.*, 2000). On the other hand, the Ser 32 mutant lost the hydroperoxy lipid peroxidase activity (Ralat *et al.*, 2006). Thus differential effect on  $H_2O_2$  and phospholipid hydroperoxides suggests that an intact phospholipase catalytic site is needed for binding and positioning of hydroperoxy lipid substrates in the peroxidase catalytic cleft, a structural requirement that would not be needed for  $H_2O_2$ .

#### 5.4. Prx VI and Surfactant Phospholipid Metabolism

Models of altered Prx VI expression have been used to evaluate the role of aiPLA<sub>2</sub> activity in lung surfactant phospholipid metabolism. Degradation of phospholipid was determined following airway instillation of liposomes containing DPPC with a radiolabel in the choline moiety (Fisher *et al.*, 2005), for a survey, see Fig. 7. Alterations of Prx VI expression had no effect on the rate of endocytosis of DPPC from the alveolar space. However, degradation of internalized DPPC was markedly depressed in Prx VI null mice and conversely was significantly increased with Prx VI over-expression. The effect in the Prx VI null mice was similar in magnitude to the inhibitory effect of MJ33 in wild type lungs indicating that the pharmacologic effect of MJ33 is due to inhibition of aiPLA<sub>2</sub> activity (Fisher *et al.*, 2005). The increased PLA<sub>2</sub> activity in overexpressing lungs was abolished by MJ33 (Fisher *et al.*, 2005).

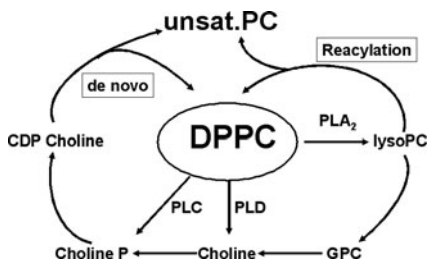

*Figure 7.* Schematic representation of the pathways for degradation of dipalmitoylphosphatidylcholine (DPPC) and the resynthesis of phosphatidylcholine following instillation of choline-labeled DPPC in the lung. In the murine lung, about half of the instilled phospholipid is catabolized by phospholipase A<sub>2</sub> enzymes, mostly Prx VI, while the remaining half is catabolized by phospholipases C and D. The choline-containing products are reutilized by either the de novo or reacylation pathways to regenerate DPPC or form PC with an unsaturated fatty acid in the sn-2 position

In addition to free fatty acid, the other product of PLA<sub>2</sub> activity is lysophospholipid. This metabolite serves as a substrate for reacylation by an acyl transferase to regenerate an sn 1,2- phospholipid. To evaluate pathways for DPPC synthesis in intact mice <sup>3</sup>H-choline and <sup>14</sup>C-palmitate were simultaneously injected intravenously and their incorporation into DPPC was measured. Incorporation of choline reflects synthesis by the *de novo* pathway, while incorporation of palmitate reflects both the *de novo* and the deacylation/reacylation pathways. For both Prx VI null and over-expressing mice, only modest differences compared to wild type were observed in choline incorporation indicating relatively unaltered *de novo* synthesis. However, incorporation of palmitate into DPPC was markedly depressed in the Prx VI null mice (Fisher *et al.*, 2005) (Fig. 8) and was significantly increased in the Prx VI overexpressing mice (Fisher *et al.*, 2006). Thus, deacylation/reacylation was decreased with Prx VI knock-out and increased with Prx VI overexpression. These results indicate that the PLA<sub>2</sub> activity of Prx VI plays an important role in the metabolism of surfactant phospholipids and affects both phospholipid degradation as well as a major pathway of DPPC synthesis.

The presence of fully active Prx VI in lamellar bodies could result in uncontrolled hydrolysis of surfactant phospholipids. It had been shown previously that surfactant protein A (SP-A) specifically inhibited certain members of the group II phospholipase A<sub>2</sub> family (Fisher *et al.*, 1994; Arbibe *et al.*, 1998). SP-A added to alveolar type II cells in culture inhibited the degradation of DPPC (Jain *et al.*, 2003) and inhibited the PLA<sub>2</sub> activity of recombinant Prx VI *in vitro* (Wu *et al.*, 2006). Reversal of a functional effect of protein-protein interaction in the lamellar body was demonstrated by a significant increase in lamellar body aiPLA<sub>2</sub> activity with SP-A alkylation or with SP-A gene targeting (Fisher *et al.*, 1994; Jain *et al.*, 2003). More recent studies demonstrated non-competitive inhibition of Prx VI phospholipase A<sub>2</sub>

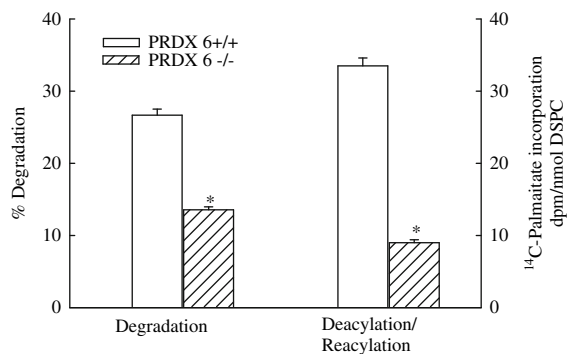

Figure 8. Physiological role of the phospholipase A<sub>2</sub> activity of Prx VI as determined with Prx VI null mice. Degradation was determined from the decrease in radioactive label in DPPC at 2 h following its instillation into the airspace of the lung. Synthesis by the deacylation/reacylation pathway was determined from the appearance of radiolabel in DPPC at 24 h following the intravenous injection of <sup>3</sup>H-palmitic acid. (Reproduced from Fisher *et al.*, 2005)

activity by SP-A, as well as a protein-protein interaction using several biophysical and biochemical techniques (Wu *et al.*, 2006). The degradation of internalized surfactant phospholipid occurs primarily in the lysosomal compartment where Prx VI is found. Possibly Prx VI is active during the early stages of surfactant recycling in the lysosome when phospholipase A<sub>2</sub> activity is required, but could be inhibited subsequently with the accretion of SP-A into the lamellar body.

## 6. PEROXIREDOXINS IN LUNG DISEASE

Alterations in the normal level of Prx VI have been observed for a number of lung diseases, although to date, the involvement of altered enzymatic activity in disease pathogenesis has not been demonstrated.

### 6.1. Acute Lung Injury

Acute Lung Injury (ALI) is a descriptive term that is used to describe the lung response to a broad range of insults such as sepsis, viral and other pneumonias, trauma, acute pancreatitis, and a variety of other morbidities that secondarily affect the lung and lead to respiratory failure. The underlying mechanisms are poorly understood but the generation of reactive oxygen species is thought to play a role in pathogenesis of the syndrome. Potential sources of ROS include the plasma membrane NADPH oxidase of activated neutrophils, macrophages, and endothelial cells, xanthine oxidase activated during tissue ischemia, therapeutic administration of oxygen at high concentration, and treatment with, or inadvertent administration of, redox-active drugs. The increased generation of ROS can damage cells through oxidation (peroxidation) of cellular lipids, proteins, DNA and other key cellular elements. Peroxidation of unsaturated phospholipids in the alveolar lining fluid has been reported under conditions of oxidative stress (Bouhafs and Jarstrand, 1999; Bouhafs *et al.*, 2003). Peroxidation of phospholipids impairs the surface tension reducing functions of the lung surfactant (Gilliard *et al.*, 1994) and secondarily can oxidize and inactivate surfactant protein A (Kuzmenko *et al.*, 2004), possibly impairing the role of this protein in phospholipid turnover. Altered surfactant function can contribute to alveolar collapse and thereby worsen the abnormal gas exchange that is the hallmark of ALI. To date, possible alterations in the expression of peroxiredoxins and their possible role in acute lung injury has not been evaluated. The results obtained with animal models suggest that alterations in the expression of Prx VI could play a significant role in susceptibility to ALI and its subsequent course in individuals exposed to one of the etiologic factors.

### 6.2. Lung Cancer

Differential screening for Prx I showed two-fold overexpression in a cancer-derived cell line compared to human normal lung epithelial cells (Chang *et al.*, 2001). In lung cancer tissues, Prx I expression was strikingly increased compared to normal

surrounding tissue in 4 out of 4 samples, whereas Prx III levels were unchanged. The authors hypothesized that overexpression of Prx I might confer a survival advantage upon neoplastic cells in those patients who develop lung cancer and who as a majority smoke, a powerful oxidative stress to the lungs. Consistent with these observations, stable transfection of two lung cancer-derived cell lines with an antisense construct downregulated the expression of Prx I; when injected into the flank of nude mice, the antisense-treated cells showed a significant delay of tumor progression and increased sensitivity to radiation treatment (Chen *et al.*, 2006).

Auto-antibodies to Prx I were found in 25 (47%) of 53 patients with non-small cell lung cancer but in only 4 (8%) of 50 normal individuals (Chang *et al.*, 2005). The circulating antigen, Prx I, could be detected in 34% of the patients and the authors suggested that this could be used as a biomarker for early cancer detection; whether the presence of those particular auto-antibodies allows for prolonged survival as has been described for other epitopes was not determined. In a larger cohort of patients with lung cancer (Lehtonen *et al.*, 2004), Prx I, IV and VI were highly expressed in the neoplastic tissue. Prx IV was more specifically associated with adenocarcinoma of the lung, and there was a positive association between tumor grade and level of expression of Prx VI in squamous cell bronchogenic cancers. These observations suggest that the peroxiredoxins are involved in oncogenesis, either because of their role in signal transduction (Rhee *et al.*, 2005) or in antioxidant defense thereby conferring survival advantages to emerging neoplastic clones (Kinnula *et al.*, 2004).

### 6.3. Mesothelioma

Mesothelioma is a unique tumor affecting the epithelial lining of the lungs (Pisani *et al.*, 1988) that results most commonly as a consequence of prior asbestos exposure. Asbestos fibers are sequestered in the pleura and lead to ROS production, mediated either directly by the presence of iron in the fibers or indirectly by consequence of the intense inflammatory response (Mossman and Churg, 1998). Levels of Prx I, II, V and VI are present at very high levels in this cancer, whereas little or none is present in the normal pleural tissue (Kinnula *et al.*, 2002b).

### 6.4. Sarcoidosis

Sarcoidosis is an inflammatory disease that can potentially affect all organs but primarily results in well organized non-caseating granulomatous lesions in the lung (Baughman *et al.*, 2003). The underlying cause remains unknown. Recent studies have pointed to inadequate immune clearance of microorganisms of low virulence in genetically predisposed patients. Previously, increased expression of MnSOD (Lakari *et al.*, 1998) and thioredoxin (Koura *et al.*, 2000) were found in the granulomatous tissue. More recently, high expression of Prx I, III and VI has been found in the granulomas (Kinnulan *et al.*, 2002a) but there was no “spillover” into the bronchoalveolar fluid.

## 7. CONCLUSIONS AND SPECULATION

It has become increasingly clear that many, perhaps the majority, of proteins in the cell serve more than one function and qualify as “moonlighting” proteins (Jeffery, 1999). A common pattern is for a protein that functions as an enzyme also to function as a structural or binding protein. Prx VI is unique in having two very different enzymatic activities. We postulate that the primary physiological role of the enzyme is to reduce peroxidized cellular phospholipids, which requires binding of Prx VI to the phospholipid substrate and insertion of the peroxidized acyl chain into the cleft containing the active site. In an evolutionary sense, a secondary gain from the novel phospholipid hydroperoxidase activity may have been the acquisition of a phospholipase activity. By analogy to the serine proteases, where loss of the catalytic triad still results in a reaction of three orders of magnitude faster relative to uncatalyzed reaction rate (Carter and Wells, 1988), rudimentary phospholipase activity could have occurred simply as a result of binding or desolvation of the phospholipid when it bound to Prx VI. This could have been the initial kernel upon which evolution subsequently enhanced its phospholipase activity by mutation in the catalytic triad to give the present mature Prx VI with its dual “moonlighting” function.

## ACKNOWLEDGEMENTS

We thank Chandra Dodia and Yan Wang for assistance in generation of figures and Susan Turbitt for typing the manuscript, and express our appreciation to collaborators Luis Ralat and Roberta Colman for their valuable insights. Original research was supported by NIH grants HL19737 and HL079063.

## REFERENCES

- Akiba, S., Dodia, C., Chen, X., Fisher, A.B., 1998, Characterization of acidic Ca(2+)-independent phospholipase A2 of bovine lung. *Comp. Biochem. Physiol. B. Biochem. Mol. Biol.* **120**: 393–404.
- Antunes, F., Han, D., Cadenas, E., 2002, Relative contributions of heart mitochondria glutathione peroxidase and catalase to H<sub>2</sub>O<sub>2</sub> detoxification in vivo conditions. *Free Radic. Biol. Med.* **33**: 1260–1267.
- Arbibe, L., Koumanov, K., Vial, D., Rougeot, C., Faure, G., Havet, N., Longacre, S., Vargaftig, B.B., Bereziat, G., Voelker, D.R., Wolf, C., Touqui, L., 1998, Generation of lyso-phospholipids from surfactant in acute lung injury is mediated by type-II phospholipase A2 and inhibited by a direct surfactant protein A-phospholipase A2 protein interaction. *J. Clin. Invest.* **102**: 1152–1160.
- Batenburg, J.J., Haagsman, H.P., 1998, The lipids of pulmonary surfactant: dynamics and interactions with proteins. *Prog. Lipid Res.* **37**: 235–276.
- Baughman, R.P., Lower, E.E., du Bois, R.M., 2003, Sarcoidosis. *Lancet* **361**: 1111–1118.
- Bouhaf, R.K., Jarstrand, C., 1999, Lipid peroxidation of lung surfactant by bacteria. *Lung* **177**: 101–110.
- Bouhaf, R.K., Samuelson, A., Jarstrand, C., 2003, Lipid peroxidation of lung surfactant due to reactive oxygen species released from phagocytes stimulated by bacteria from children with cystic fibrosis. *Free Radic. Res.* **37**: 909–917.
- Brenner, S., 1988, The molecular evolution of genes and proteins: a tale of two serines. *Nature* **334**: 528–530.

- Chae, H.Z., Kim, H.J., Kang, S.W., Rhee, S.G., 1999, Characterization of three isoforms of mammalian peroxiredoxin that reduce peroxides in the presence of thioredoxin. *Diabetes Res. Clin. Pract.* **45**: 101–112.
- Chang, J.W., Jeon, H.B., Lee, J.H., Yoo, J.S., Chun, J.S., Kim, J.H., Yoo, Y.J., 2001, Augmented expression of peroxiredoxin I in lung cancer. *Biochem. Biophys. Res. Commun.* **289**: 507–512.
- Chang, J.W., Lee, S.H., Jeong, J.Y., Chae, H.Z., Kim, Y.C., Park, Z.Y., Yoo, Y.J., 2005, Peroxiredoxin-I is an autoimmunogenic tumor antigen in non-small cell lung cancer. *FEBS Lett.* **579**: 2873–2877.
- Chang, T.S., Jeong, W., Woo, H.A., Lee, S.M., Park, S., Rhee, S.G., 2004, Characterization of mammalian sulfiredoxin and its reactivation of hyperoxidized peroxiredoxin through reduction of cysteine sulfinic acid in the active site to cysteine. *J. Biol. Chem.* **279**: 50994–51001.
- Chen, J.W., Dodia, C., Feinstein, S.I., Jain, M.K., Fisher, A.B., 2000, l-Cys peroxiredoxin, a bifunctional enzyme with glutathione peroxidase and phospholipase A2 activities. *J. Biol. Chem.* **275**: 28421–28427.
- Chen, M.F., Keng, P.C., Shau, H., Wu, C.T., Hu, Y.C., Liao, S.K., Chen, W.C., 2006, Inhibition of lung tumor growth and augmentation of radiosensitivity by decreasing peroxiredoxin I expression. *Int. J. Radiat. Oncol. Biol. Phys.* **64**: 581–591.
- Choi, H.J., Kang, S.W., Yang, C.H., Rhee, S.G., Ryu, S.E., 1998, Crystal structure of a novel human peroxidase enzyme at 2.0 Å resolution. *Nat. Struct. Biol.* **5**: 400–406.
- Das, K.C., Pahl, P.M., Guo, X.L., White, C.W., 2001, Induction of peroxiredoxin gene expression by oxygen in lungs of newborn primates. *Am. J. Respir. Cell. Mol. Biol.* **25**: 226–232.
- Declercq, J.P., Evrard, C., Clippe, A., Stricht, D.V., Bernard, A., Knoops, B., 2001, Crystal structure of human peroxiredoxin 5, a novel type of mammalian peroxiredoxin at 1.5 Å resolution. *J. Mol. Biol.* **311**: 751–759.
- Dierick, J.F., Wenders, F., Chainiaux, F., Remacle, J., Fisher, A.B., Toussaint, O., 2003, Retrovirally mediated overexpression of peroxiredoxin VI increases the survival of WI-38 human diploid fibroblasts exposed to cytotoxic doses of tert-butylhydroperoxide and UVB. *Biogerontology* **4**: 125–131.
- Ding, L., Liu, Z., Zhu, Z., Luo, G., Zhao, D., Ni, J., 1998, Biochemical characterization of selenium-containing catalytic antibody as a cytosolic glutathione peroxidase mimic. *Biochem. J.* **332** (Pt 1): 251–255.
- Evrard, C., Capron, A., Marchand, C., Clippe, A., Wattiez, R., Soumillion, P., Knoops, B., Declercq, J.P., 2004, Crystal structure of a dimeric oxidized form of human peroxiredoxin 5. *J. Mol. Biol.* **337**: 1079–1090.
- Fisher, A.B., Al-Mehdi, A.B., Muzykantov, V., 1999a, Activation of endothelial NADPH oxidase as the source of a reactive oxygen species in lung ischemia. *Chest* **116**: 25S–26S.
- Fisher, A.B., Dodia, C., 1996, Role of phospholipase A2 enzymes in degradation of dipalmitoylphosphatidylcholine by granular pneumocytes. *J. Lipid Res.* **37**: 1057–1064.
- Fisher, A.B., Dodia, C., 1997, Role of acidic Ca<sup>2+</sup>-independent phospholipase A2 in synthesis of lung dipalmitoyl phosphatidylcholine. *Am. J. Physiol.* **272**: L238–243.
- Fisher, A.B., Dodia, C., 2001, Lysosomal-type PLA2 and turnover of alveolar DPPC. *Am. J. Physiol. Lung Cell. Mol. Physiol.* **280**: L748–754.
- Fisher, A.B., Dodia, C., Chander, A., 1994, Inhibition of lung calcium-independent phospholipase A2 by surfactant protein A. *Am. J. Physiol.* **267**: L335–341.
- Fisher, A.B., Dodia, C., Feinstein, S.I., Ho, Y. S., 2005, Altered lung phospholipid metabolism in mice with targeted deletion of lysosomal-type phospholipase A2. *J. Lipid Res.* **46**: 1248–1256.
- Fisher, A.B., Dodia, C., Manevich, Y., Chen, J.W., Feinstein, S.I., 1999b, Phospholipid hydroperoxides are substrates for non-selenium glutathione peroxidase. *J. Biol. Chem.* **274**: 21326–21334.
- Fisher, A.B., Dodia, C., Yu, K., Manevich, Y., Feinstein, S.I., 2006, Lung phospholipid metabolism in transgenic mice overexpressing peroxiredoxin 6. *Biochim. Biophys. Acta* **1761**: 785–792.
- Flohé, L., Brigelius-Flohé, R., 2001, Selenoproteins of the glutathione system. in D. L. Hatfield: Selenium. Its Molecular Biology and Role in Human Health. London, Kluwer Academic Publishers, pp. 157–178.
- Fujii, T., Fujii, J., Taniguchi, N., 2001, Augmented expression of peroxiredoxin VI in rat lung and kidney after birth implies an antioxidative role. *Eu. J. Biochem.* **268**: 218–225.



- Fukuhara, R., Kageyama, T., 2005, Structure, gene expression, and evolution of primate glutathione peroxidases. *Comp. Biochem. Physiol. B Biochem. Mol. Biol.* **141**: 428–436.
- Gilliard, N., Heldt, G.P., Loredto, J., Gasser, H., Redl, H., Merritt, T.A., Spragg, R.G., 1994, Exposure of the hydrophobic components of porcine lung surfactant to oxidant stress alters surface tension properties. *J. Clin. Invest.* **93**: 2608–2615.
- Grossmann, A., Wendel, A., 1983, Non-reactivity of the selenoenzyme glutathione peroxidase with enzymatically hydroperoxidized phospholipids. *Eur. J. Biochem.* **135**: 549–552.
- Hirotsu, S., Abe, Y., Okada, K., Nagahara, N., Hori, H., Nishino, T., Hakoshima, T., 1999, Crystal structure of a multifunctional 2-Cys peroxiredoxin heme-binding protein 23 kDa/proliferation-associated gene product. *Proc. Natl. Acad. Sci. U S A* **96**: 12333–12338.
- Ho, Y.S., Magnenat, J.L., Bronson, R.T., Cao, J., Gargano, M., Sugawara, M., Funk, C.D., 1997, Mice deficient in cellular glutathione peroxidase develop normally and show no increased sensitivity to hyperoxia. *J. Biol. Chem.* **272**: 16644–16651.
- Hofmann, B., Hecht, H.J., Flöhé, L., 2002, Peroxiredoxins. *Biol. Chem.* **383**: 347–364.
- Iakoubova, O.A., Pacella, L.A., Her, H., Beier, D.R., 1997, LTW4 protein on mouse chromosome 1 is a member of a family of antioxidant proteins. *Genomics* **42**: 474–478.
- Jain, D., Dodia, C., Bates, S.R., Hawgood, S., Poulain, F.R., Fisher, A.B., 2003, SP-A is necessary for increased clearance of alveolar DPPC with hyperventilation or secretagogues. *Am. J. Physiol. Lung Cell. Mol. Physiol.* **284**: L759–765.
- Kang, S.W., Baines, I.C., Rhee, S.G., 1998, Characterization of a mammalian peroxiredoxin that contains one conserved cysteine. *J. Biol. Chem.* **273**: 6303–6311.
- Kim, H. S., Kang, S. W., Rhee, S. G., and Clerch, L. B., 2001, Rat lung peroxiredoxins I and II are differentially regulated during development and by hyperoxia. *Am. J. Physiol. Lung Cell. Mol. Physiol.* **280**: L1212–1217.
- Kim, H.S., Manevich, Y., Feinstein, S.I., Pak, J.H., Ho, Y.S., Fisher, A.B., 2003, Induction of 1-cys peroxiredoxin expression by oxidative stress in lung epithelial cells. *Am. J. Physiol. Lung Cell. Mol. Physiol.* **285**: L363–369.
- Kim, H.S., Pak, J.H., Gonzales, L.W., Feinstein, S.I., Fisher, A.B., 2002, Regulation of 1-cys peroxiredoxin expression in lung epithelial cells. *Am. J. Respir. Cell. Mol. Biol.* **27**: 227–233.
- Kim, T.S., Dodia, C., Chen, X., Hennigan, B.B., Jain, M., Feinstein, S.I., Fisher, A.B., 1998, Cloning and expression of rat lung acidic Ca(2+)-independent PLA2 and its organ distribution. *Am. J. Physiol.* **274**: L750–761.
- Kim, T.S., Sundaresh, C.S., Feinstein, S.I., Dodia, C., Skach, W.R., Jain, M.K., Nagase, T., Seki, N., Ishikawa, K., Nomura, N., Fisher, A.B., 1997, Identification of a human cDNA clone for lysosomal type Ca2+-independent phospholipase A2 and properties of the expressed protein. *J. Biol. Chem.* **272**: 2542–2550.
- Kinnula, V.L., Lehtonen, S., Kaartenaho-Wiik, R., Lakari, E., Paakko, P., Kang, S.W., Rhee, S.G., Soini, Y., 2002a, Cell specific expression of peroxiredoxins in human lung and pulmonary sarcoidosis. *Thorax* **57**: 157–164.
- Kinnula, V.L., Lehtonen, S., Sormunen, R., Kaartenaho-Wiik, R., Kang, S. W., Rhee, S.G., Soini, Y., 2002b, Overexpression of peroxiredoxins I, II, III, V, and VI in malignant mesothelioma. *J. Pathol.* **196**: 316–323.
- Kinnula, V.L., Paakko, P., Soini, Y., 2004, Antioxidant enzymes and redox regulating thiol proteins in malignancies of human lung. *FEBS Lett.* **569**: 1–6.
- Knoops, B., Clippe, A., Bogard, C., Arsalane, K., Wattiez, R., Hermans, C., Duconseille, E., Falmagne, P., Bernard, A., 1999, Cloning and characterization of AOEB166, a novel mammalian antioxidant enzyme of the peroxiredoxin family. *J. Biol.Chem.* **274**: 30451–30458.
- Koura, T., Gon, Y., Hashimoto, S., Azuma, A., Kudoh, S., Fukuda, Y., Sugawara, I., Yodoi, J., Horie, T., 2000, Expression of thioredoxin in granulomas of sarcoidosis: possible role in the development of T lymphocyte activation. *Thorax* **55**: 755–761.
- Kuzmenko, A.I., Wu, H., Bridges, J.P., McCormack, F.X., 2004, Surfactant lipid peroxidation damages surfactant protein A and inhibits interactions with phospholipid vesicles. *J. Lipid Res.* **45**: 1061–1068.

- Lakari, E., Paakko, P., Kinnula, V.L., 1998, Manganese superoxide dismutase, but not CuZn superoxide dismutase, is highly expressed in the granulomas of pulmonary sarcoidosis and extrinsic allergic alveolitis. *Am. J. Respir. Crit. Care Med.* **158**: 589–596.
- Leavey, P.J., Gonzalez-Aller, C., Thurman, G., Kleinberg, M., Rinckel, L., Ambruso, D. W., Freeman, S., Kuypers, F.A., Ambruso, D.R., 2002, A 29-kDa protein associated with p67phox expresses both peroxiredoxin and phospholipase A2 activity and enhances superoxide anion production by a cell-free system of NADPH oxidase activity. *J. Biol. Chem.* **277**: 45181–45187.
- Lee, J.H., Daud, A.N., Cribbs, L.L., Lacerda, A.E., Pereverzev, A., Klockner, U., Schneider, T., Perez-Reyes, E., 1999, Cloning and expression of a novel member of the low voltage-activated T-type calcium channel family. *J. Neurosci.* **19**: 1912–1921.
- Lee, S.P., Hwang, Y.S., Kim, Y.J., Kwon, K.S., Kim, H.J., Kim, K., Chae, H.Z., 2001, Cyclophilin a binds to peroxiredoxins and activates its peroxidase activity. *J. Biol. Chem.* **276**: 29826–29832.
- Lee, T.H., Kim, S.J., Kang, S.W., Lee, K.K., Rhee, S.G., Yu, D.Y., 2000, Molecular cloning and characterization of the mouse peroxiredoxin V gene. *Biochem. Biophys. Res. Commun.* **270**: 356–362.
- Lehtonen, S.T., Svensk, A.M., Soini, Y., Paakko, P., Hirvikoski, P., Kang, S.W., Saily, M., Kinnula, V.L., 2004, Peroxiredoxins, a novel protein family in lung cancer. *Int. J. Cancer* **111**: 514–521.
- Leyens, G., Donnay, I., Knoops, B., 2003, Cloning of bovine peroxiredoxins-gene expression in bovine tissues and amino acid sequence comparison with rat, mouse and primate peroxiredoxins. *Comp. Biochem. Physiol. B Biochem. Mol. Biol.* **136**: 943–955.
- Manevich, Y., Feinstein, S.I., Fisher, A.B., 2004, Activation of the antioxidant enzyme 1-CYS peroxiredoxin requires glutathionylation mediated by heterodimerization with pi GST. *Proc Natl. Acad. Sci. U S A* **101**: 3780–3785.
- Manevich, Y., Fisher, A.B., 2005, Peroxiredoxin 6, a 1-Cys peroxiredoxin, functions in antioxidant defense and lung phospholipid metabolism. *Free Radic. Biol. Med.* **38**: 1422–1432.
- Manevich, Y., Reddy, K. S., Shuvaeva, T., Feinstein, S.I., Fisher, A.B. (2005). Circular dichroism (CD) and fluorescence studies of phospholipids to peroxiredoxin 6 (Prdx 6). FASEB J.
- Manevich, Y., Sweitzer, T., Pak, J.H., Feinstein, S.I., Muzykantov, V., Fisher, A.B., 2002, 1-Cys peroxiredoxin overexpression protects cells against phospholipid peroxidation-mediated membrane damage. *Proc. Natl. Acad. Sci. U S A* **99**: 11599–11604.
- Matsumoto, A., Okado, A., Fujii, T., Fujii, J., Egashira, M., Niikawa, N., Taniguchi, N., 1999, Cloning of the peroxiredoxin gene family in rats and characterization of the fourth member. *FEBS Lett.* **443**: 246–250.
- Michiels, C., Raes, M., Toussaint, O., Remacle, J., 1994, Importance of Se-glutathione peroxidase, catalase, and Cu/Zn-SOD for cell survival against oxidative stress. *Free Radic. Biol. Med.* **17**: 235–248.
- Mo, Y., Feinstein, S. I., Manevich, Y., Zhang, Q., Lu, L., Ho, Y.S., Fisher, A.B., 2003, 1-Cys peroxiredoxin knock-out mice express mRNA but not protein for a highly related intronless gene. *FEBS Lett.* **555**: 192–198.
- Mossmann, B.T., Churg, A., 1998, Mechanisms in the pathogenesis of asbestosis and silicosis. *Am. J. Respir. Crit. Care Med.* **157**: 1666–1680.
- Munz, B., Frank, S., Hubner, G., Olsen, E., Werner, S., 1997, A novel type of glutathione peroxidase: expression and regulation during wound repair. *Biochem. J.* **326 (Pt 2)**: 579–585.
- Nagase, T., Miyajima, N., Tanaka, A., Sazuka, T., Seki, N., Sato, S., Tabata, S., Ishikawa, K., Kawarabayasi, Y., Kotani, H., et al., 1995, Prediction of the coding sequences of unidentified human genes. III. The coding sequences of 40 new genes (K1AA0081-K1AA0120) deduced by analysis of cDNA clones from human cell line KG-1 (supplement). *DNA Res.* **2**: 51–59.
- Nardini, M., Dijkstra, B.W., 1999, Alpha/beta hydrolase fold enzymes: the family keeps growing. *Curr. Opin. Struct. Biol.* **9**: 732–737.
- Noguera-Mazon, V., Lemoine, J., Walker, O., Rouhier, N., Salvador, A., Jacquot, J.P., Lancelin, J.M., Krimm, I., 2006, Glutathionylation induces the dissociation of 1-Cys D-peroxiredoxin non-covalent homodimer. *J. Biol. Chem.* **281**: 31736–31742.
- Ollis, D.L., Cheah, E., Cygler, M., Dijkstra, B., Frolow, F., Franken, S.M., Harel, M., Remington, S.J., Silman, I., Schrag, J., et al., 1992, The alpha/beta hydrolase fold. *Protein Eng.* **5**: 197–211.

- Pak, J.H., Manevich, Y., Kim, H.S., Feinstein, S.I., Fisher, A.B., 2002, An antisense oligonucleotide to 1-cys peroxiredoxin causes lipid peroxidation and apoptosis in lung epithelial cells. *J. Biol. Chem.* **277**: 49927–49934.
- Peshenko, I.V., Novoselov, V.I., Evdokimov, V.A., Nikolaev Y.V., Shuvaeva, T.M., Lipkin, V.M., Fesenko, E.E., 1996, Novel 28-kDa secretory protein from rat olfactory epithelium. *FEBS Lett.* **381**: 12–14.
- Peshenko, I.V., Novoselov, V.I., Evdokimov, V.A., Nikolaev, Y.V., Kamzalov, S.S., Shuvaeva, T.M., Lipkin, V.M., Fesenko, E.E., 1998, Identification of a 28 kDa secretory protein from rat olfactory epithelium as a thiol-specific antioxidant. *Free Radic. Biol. Med.* **25**: 654–659.
- Peshenko, I.V., Shichi, H., 2001, Oxidation of active center cysteine of bovine 1-Cys peroxiredoxin to the cysteine sulfenic acid form by peroxide and peroxyxynitrite. *Free Radic. Biol. Med.* **31**: 292–303.
- Peshenko, I.V., Singh, A.K., Shichi, H., 2001, Bovine eye 1-Cys peroxiredoxin: expression in E. coli and antioxidant properties. *J. Ocul. Pharmacol. Ther.* **17**: 93–99.
- Phelan, S.A., Beier, D.R., Higgins, D.C., Paigen, B., 2002, Confirmation and high resolution mapping of an atherosclerosis susceptibility gene in mice on Chromosome 1. *Mamm. Genome* **13**: 548–553.
- Phelan, S.A., Johnson, K.A., Beier, D.R., Paigen, B., 1998, Characterization of the murine gene encoding Aop2 (antioxidant protein 2) and identification of two highly related genes. *Genomics* **54**: 132–139.
- Pisani, R.J., Colby, T.V., Williams, D.E., 1988, Malignant mesothelioma of the pleura. *Mayo Clin. Proc.* **63**: 1234–1244.
- Poole, L.B., Karplus, P.A., Claiborne, A., 2004, Protein sulfenic acids in redox signaling. *Annu. Rev. Pharmacol. Toxicol.* **44**: 325–347.
- Power, J.H., Nicholas, T.E., 1999, Immunohistochemical localization and characterization of a rat Clara cell 26-kDa protein (CC26) with similarities to glutathione peroxidase and phospholipase A2. *Exp. Lung. Res.* **25**: 379–392.
- Ralat, L.A., Manevich, Y., Fisher, A.B., Colman, R.F., 2006, Direct evidence for the formation of a complex between 1-cysteine peroxiredoxin and glutathione S-transferase pi with activity changes in both enzymes. *Biochemistry* **45**: 360–372.
- Rhee, S.G., Kang, S.W., Chang, T.S., Jeong, W., Kim, K., 2001, Peroxiredoxin, a novel family of peroxidases. *IUBMB Life* **52**: 35–41.
- Rhee, S.G., Kang, S.W., Jeong, W., Chang, T.S., Yang, K.S., Woo, H.A., 2005, Intracellular messenger function of hydrogen peroxide and its regulation by peroxiredoxins. *Curr. Opin. Cell Biol.* **17**: 183–189.
- Rhee, S.G., Kang, S.W., Netto, L.E., Seo, M.S., Stadtman, E.R., 1999, A family of novel peroxidases, peroxiredoxins. *Biofactors* **10**: 207–209.
- Sevanian, A., Muakkassah-Kelly, S.F., Montestruque, S., 1983, The influence of phospholipase A2 and glutathione peroxidase on the elimination of membrane lipid peroxides. *Arch. Biochem. Biophys.* **223**: 441–452.
- Shichi, H., 1990, Glutathione-dependent detoxification of peroxide in bovine ciliary body. *Exp Eye Res.* **50**: 813–818.
- Shichi, H., Demar, J.C., 1990, Non-selenium glutathione peroxidase without glutathione S-transferase activity from bovine ciliary body. *Exp. Eye Res.* **50**: 513–520.
- Simeone, M., Phelan, S.A., 2005, Transcripts associated with Prdx6 (peroxiredoxin 6) and related genes in mouse. *Mamm. Genome* **16**: 103–111.
- Sinning, I., Kleywegt, G. J., Cowan, S.W., Reinemer, P., Dirr, H.W., Huber, R., Gilliland, G.L., Armstrong, R.N., Ji, X., Board, P.G., *et al.*, 1993, Structure determination and refinement of human alpha class glutathione transferase A1–1, and a comparison with the Mu and Pi class enzymes. *J. Mol. Biol.* **232**: 192–212.
- Six, D.A., Dennis, E.A., 2000, The expanding superfamily of phospholipase A(2) enzymes: classification and characterization. *Biochim. Biophys. Acta* **1488**: 1–19.
- Sparling, N.E., Phelan, S.A., 2003, Identification of multiple transcripts for antioxidant protein 2 (Aop2): differential regulation by oxidative stress and growth factors. *Redox Rep.* **8**: 87–94.
- Stripp, B.R., Reynolds, S.D., Boe, I.M., Lund, J., Power, J.H., Coppens, J.T., Wong, C.M., Reynolds, P.R., Plopper, C.G., 2002, Clara cell secretory protein deficiency alters clara cell secretory

- apparatus and the protein composition of airway lining fluid. *Am. J. Respir. Cell. Mol. Biol.* **27**: 170–178.
- Tolle, A., Schlame, M., Charlier, N., Guthmann, F., Rustow, B., 2005, Vitamin E differentially regulates the expression of peroxiredoxin-1 and -6 in alveolar type II cells. *Free Radic. Biol. Med.* **38**: 1401–1408.
- Ursini, F., Maiorino, M., Brigelius-Flohe, R., Aumann, K.D., Roveri, A., Schomburg, D., Flohe, L., 1995, Diversity of glutathione peroxidases. *Methods Enzymol.* **252**: 38–53.
- Wang, X., Phelan, S.A., Forsman-Semb, K., Taylor, E.F., Petros, C., Brown, A., Lerner, C.P., Paigen, B., 2003, Mice with targeted mutation of peroxiredoxin 6 develop normally but are susceptible to oxidative stress. *J. Biol. Chem.* **278**: 25179–25190.
- Wang, X., Phelan, S.A., Petros, C., Taylor, E.F., Ledinski, G., Jurgens, G., Forsman-Semb, K., Paigen, B., 2004a, Peroxiredoxin 6 deficiency and atherosclerosis susceptibility in mice: significance of genetic background for assessing atherosclerosis. *Atherosclerosis* **177**: 61–70.
- Wang, Y., Feinstein, S.I., Manevich, Y., Ho, Y.S., Fisher, A.B., 2004b, Lung injury and mortality with hyperoxia are increased in peroxiredoxin 6 gene-targeted mice. *Free Radic. Biol. Med.* **37**: 1736–1743.
- Wang, Y., Feinstein, S.I., Manevich, Y., Ho, Y.S., Fisher, A.B., 2006a, Peroxiredoxin 6 gene-targeted mice show increased lung injury with paraquat-induced oxidative stress. *Antioxid. Redox Signal.* **8**: 229–237.
- Wang, Y., Manevich, Y., Feinstein, S.I., Fisher, A.B., 2004c, Adenovirus-mediated transfer of the 1-cys peroxiredoxin gene to mouse lung protects against hyperoxic injury. *Am. J. Physiol. Lung Cell. Mol. Physiol.* **286**: L1188–1193.
- Wang, Y., Phelan, S.A., Manevich, Y., Feinstein, S.I., Fisher, A.B., 2006, Transgenic mice overexpressing peroxiredoxin 6 show increased resistance to lung injury in hyperoxia. *Am. J. Respir. Cell Mol. Biol.* **34**: 481–486.
- Wattiez, R., Hermans, C., Bernard, A., Lesur, O., Falmagne, P., 1999, Human bronchoalveolar lavage fluid: two-dimensional gel electrophoresis, amino acid microsequencing and identification of major proteins. *Electrophoresis* **20**: 1634–1645.
- Wattiez, R., Hermans, C., Cruyt, C., Bernard, A., Falmagne, P., 2000, Human bronchoalveolar lavage fluid protein two-dimensional database: study of interstitial lung diseases. *Electrophoresis* **21**: 2703–2712.
- Whitsett, J.A., Weaver, T.E., 2002, Hydrophobic surfactant proteins in lung function and disease. *New Engl. J. Med.* **347**: 2141–2148.
- Wood, Z.A., Schroder, E., Harris, J.R., Poole, L.B., 2003, Structure, mechanism and regulation of peroxiredoxins. *Trends Biochem. Sci.* **28**: 32–40.
- Wu, Y.Z., Manevich, Y., Baldwin, J.L., Dodia, C., Yu, K., Feinstein, S.I., Fisher, A.B., 2006, Interaction of surfactant protein A with peroxiredoxin 6 regulates phospholipase A2 activity. *J. Biol. Chem.* **281**: 7515–7525.
- Zhao, L., Wang, H.P., Zhang, H.J., Weydert, C.J., Domann, F.E., Oberley, L.W., Buettner, G.R., 2003, L-PhGPx expression can be suppressed by antisense oligodeoxynucleotides. *Arch. Biochem. Biophys.* **417**: 212–218.

## CHAPTER 16

# PEROXIREDOXINS IN GAMETOGENESIS AND EMBRYO DEVELOPMENT

ISABELLE DONNAY<sup>1</sup> AND BERNARD KNOOPS<sup>2</sup>

<sup>1</sup>*Veterinary Unit and* <sup>2</sup>*Laboratory of Cell Biology, Institut des Sciences de la Vie, Université catholique de Louvain, Place Croix du Sud, 5, B-1348 Louvain-La-Neuve, Belgium*

**Abstract:** Reactive oxygen species have been implicated in gametogenesis and embryo development in animals. As peroxiredoxins are now recognized as important protective antioxidant enzymes as well as modulators of hydrogen peroxide-mediated signaling, we addressed here the putative role of this novel family of peroxidases in gamete maturation and during embryogenesis in mammals and insects

**Keywords:** Gametogenesis, Embryogenesis, Mammals, Insects, Reactive oxygen species, Apoptosis

## 1. GAMETES AND GONADS

### 1.1. Testis and Sperm

The testis express high levels of antioxidant enzymes (Jervis and Robaire 2001). For example, high concentrations of glutathione peroxidase 4 (GPx4) are found in testis (Roveri *et al.*, 2001) and low levels of expression of this peroxidase have been related to male infertility in humans (Maiorino *et al.*, 2003).

Transcripts coding for all peroxiredoxins (Prxs for human/bovine peroxiredoxins and Prxs for murine orthologs) are found in testis, seminal vesicles and epididymis in bulls, with various levels of expression (Leyens *et al.*, 2003). Indeed, *Prx4* and *Prx5*, and to a lesser extent *Prx1*, are highly expressed in the testis, while *Prx2* and *Prx5* are highly expressed in seminal vesicles. The epididymis does not show a particular pattern of expression (Leyens *et al.*, 2003). *Prx1* and *Prx2* expression has also been demonstrated in mouse testis at the mRNA and protein levels (Lee *et al.*, 2002; Lim *et al.*, 1998). These Prxs were preferentially localized in the cytoplasm of Leydig and Sertoli cells, respectively, and their expression was transiently up-regulated after testis irradiation, which could contribute to the relative radiation-resistance of those cells (Lee *et al.*, 2002). In contrast, almost no expression of both proteins was observed in spermatogonia and spermatocytes.

*Prx2* is expressed at low and invariant levels (less than 1.5 fold change) along the rat epididymis (Jervis and Robaire 2001). However, it must be noted that the relative abundance of Prx proteins is not always in good agreement with the relative abundance of the transcripts, suggesting that post-transcriptional regulation may occur (Seo *et al.*, 2000).

Spermatozoa maturation occurs in the epididymal tract and is a redox-regulated process: a marked loss of sperm GSH and a shift to an oxidized state has been shown during the passage of spermatozoa from the caput to the cauda epididymis (Seligman *et al.*, 2005). The epididymal epithelium must be able to protect spermatozoa and itself from oxidative damage (Jervis and Robaire 2001). The epididymis is a rich source of antioxidant enzymes: it secretes GPx (Fouchecourt *et al.*, 2000), and produces high levels of GSH (Hinton *et al.*, 1995), catalase and superoxide dismutases (Zini *et al.*, 2002).

The seminal vesicles provide yet another line of defence against oxidative stress; they have previously been shown to secrete superoxide dismutase, GPx, catalase and GSH into the seminal fluid (Tramer *et al.*, 1998; Zubkova and Robaire, 2004). *Prx4* can be secreted by the cells and could be present in the seminal fluid as its expression has been demonstrated at the mRNA level in bovine seminal vesicle, however at lower rates than in the testis (Leyens *et al.*, 2003).

### 1.1.1. Spermatogenesis

Both *Prx1* and *Prx6* are found to be highly expressed in rat spermatogonia and Sertoli cells respectively, but to a lesser extent in spermatid (Sasagawa *et al.*, 2001). *In situ* hybridization demonstrated the expression of *Prx4* in most spermatogenic cells. However, the strongest level of protein expression was seen only in the spermatids and residual bodies in adult testis while the protein was not detected in spermatozoa (Sasagawa *et al.*, 2001).

Although *Prx4* exists as a 27-kDa secretable form in many tissues, including testis of all ages, a 31-kDa form is observable only in testis of 6- and 13 week-old adult rats (Okado-Matsumoto *et al.*, 2000). The 31-kDa form appears during sexual maturation, although gene transcript and the sum of both forms of the *Prx4* protein were observed to be about the same (Sasagawa *et al.*, 2001). Analysis of N-terminal amino-acid sequences indicates that the secretable *Prx4* is a processed form that lacks the N-terminal 36 amino-acid residues present in the amino-acid sequences deduced from the cDNA. Thus, it is likely that the 31-kDa form corresponds to an unprocessed form and, if so, it might bind to membrane components of testicular cells via the N-terminal hydrophobic stretch. Secretable 27-kDa *Prx4* has peroxidase activity, but 31-kDa *Prx4* does not. The occurrence of the 31-kDa form matches the stage of testis with the production of spermatozoa in large quantity (Sasagawa *et al.*, 2001). Specific immunoreactivity for *Prx4* is found on the membranes of the ER, in the perinuclear space and in the acrosomal membrane of the elongating spermatid but not in the mature spermatozoa. Thus all *Prx4* seems to be released into the residual body after the completion of spermiogenesis. A possible function of the membrane-bound *Prx4* could be a protein component related to vesicular

reorganization and involved in the acrosomal body formation during spermiogenesis. The peroxidase domain is expected to be present at the luminal side of the vesicles and so the protein may interact with other component(s) in the ER lumen, leading to morphological changes in the acrosome-forming vesicles. Indeed, interestingly, Prx4 has two extra cysteine residues that may play a role in interactions with the protein components of the ER, as has been seen for selenocysteine and cysteine residues, to convert GPx4 into a mitochondrial structural protein (Ursini *et al.*, 1999). The emergence of unprocessed Prx4 at the spermiogenic stage could indicate that a processing enzyme activity is suppressed at lower temperatures during spermiogenesis in testes after they reach the scrotum (Sasagawa *et al.*, 2001).

### 1.1.2. Sperm

The first cell type actually shown to produce reactive oxygen species (ROS) was the male gamete (MacLeod, 1943; Tosic and Walton, 1946). ROS production by mammalian spermatozoa has been associated with a loss of cell function and DNA integrity. These cells are highly sensitive to such oxidative attacks, as a consequence of their relative lack of cytosolic antioxidant enzymes and their relative abundance of polyunsaturated fatty acids. On the other hand, spermatozoa are intensely redox active cells and generate high levels of ROS that are physiologically important for the spermatozoa, regulating most aspects of sperm function, including movement characteristics, capacitation, sperm-zona interaction, acrosome reaction and sperm-oocyte fusion (Baker and Aitken 2004; Baker *et al.*; 2005; O'Flaherty *et al.*, 2006).

Antioxidant enzymes have been involved in the regulation of ROS production by sperm cells and of their sensitivity to oxidative stress. As far as we know, the expression of Prxs has not yet been demonstrated in mature sperm cells. However, Prxs present in the seminal plasma or in the female genital tract may play a role in ROS-regulated processes before and during fertilization.

## 1.2. Ovaries and Oocytes

All *Prxs* are expressed in bovine ovaries at the mRNA level. The expression profile presents no specific characteristics by comparison with the other bovine tissues that have been examined so far (Leyens *et al.*, 2003).

Interestingly, Prxs belong to the highly abundant porcine oocyte proteins, which also include Mn-SOD. Indeed, Prx2 is the most abundant protein in oocytes while Prx1 and Prx3 occupy respectively the 4th and 6th rank. However, their expression seems stable throughout maturation (Ellederova *et al.*, 2004). Seemingly, transcripts coding for all Prxs are found in bovine oocytes before and after maturation (Leyens *et al.*, 2004a).

A growing body of evidence indicates that pro-oxidant/anti-oxidant balance inside the ovarian follicles plays an important role in folliculogenesis (Wiener-Megnazi *et al.*, 2004). A certain threshold of ROS in the follicular fluid has been reported as a potential marker for predicting success rate of *in vitro* fertilization (Pasqualotto *et al.*, 2004). Moreover, the formation of ROS is beneficial to increase

the developmental potential of bovine oocytes during *in vitro* maturation (Blondin *et al.*, 1997), and exogenous exposure to antioxidants is reported to inhibit meiotic resumption in immature rat oocytes cultured *in vitro* (Takami *et al.*, 1999). Exogenous  $H_2O_2$  can induce germinal vesicle breakdown in immature rat oocytes but inhibits first polar body extrusion in mature oocytes prior to initiation of morphological changes characteristic of apoptosis (Chaube *et al.*, 2005). These studies indicate that a strict control of the level of  $H_2O_2$  is important for the progression of meiosis. As Prx1 and Prx2 appear to be the most abundant antioxidant enzymes in mammalian oocytes, one can predict a role for those two enzymes in such control. Indeed, recent studies suggest that, as mitosis progresses to prometaphase and the nuclear envelope breaks down, Prx1 and likely Prx2 are phosphorylated by cdc-2 (Rhee *et al.*, 2005). The phosphorylation of these two cytosolic Prx enzymes results in their inactivation and in the consequent intracellular accumulation of  $H_2O_2$ . The amount of phosphorylated Prx1 varies in parallel with the activity of cdc2 during cell cycle progression, being high in cells in the G2 and M phases but not detectable in G1 or S phase cells (Rhee *et al.*, 2005). The resulting  $H_2O_2$  can induce the inactivation of cdc25. Indeed, cdc25 contains an essential cysteine residue that is sensitive to oxidation by  $H_2O_2$  and requires the presence of reducing agents for its activity. Inactivation of cdc25 in turn can halt the positive feedback loop formed by cdc25 and cdc2. Indeed, cdc25 controls the activation of cdc2 by catalyzing the dephosphorylation of two Thr. Thus,  $H_2O_2$ , regulated at least partly by Prx1 and Prx2, may function as an inhibitor of cdc25 throughout the stages of mitosis and may affect cell cycle progression in the M phase (Rhee *et al.*, 2005).

No data are available concerning the possible control of meiosis progression by Prx1 or Prx2, but as the same actors (Prx1 and Prx2, cdc2, cdc25 and  $H_2O_2$ ) are present during meiosis resumption and progression as during G2-M transition, it can be hypothesized that similar mechanisms might be involved. Indeed, the key regulator of oocyte nuclear maturation is the M-phase promoting factor (MPF), a heterodimer composed by the serine/threonine kinase p34cdc2, which is the catalytic subunit, and cyclin B, which is the regulatory subunit. MPF activation is regulated by a cdc25 (Dekel, 2005).

Other roles for enzymes controlling  $H_2O_2$  levels in oocytes are also possible:  $H_2O_2$  is known to modulate  $K^+$  channels expressed in *Xenopus* oocytes (Vega-Saenz de Miera *et al.*, 1992) and to be able to regulate  $Ca^{2+}$  signaling ( $Ca^{2+}$  influx) by activating  $Ca^{2+}$  channels on the plasma membrane (Li *et al.*, 1998).

In cows, upregulation of *Prx6* transcription and translation occurs during *in vitro* maturation both in the oocytes and the surrounding cumulus cells (Leyens *et al.*, 2004b). This is quite surprising as very few transcripts are upregulated during oocyte maturation. Indeed, transcription is stopped soon after the breakdown of the germinal vesicle that occurs a few hours after the onset of maturation. Moreover, some deadenylation of the transcripts coding for Prx6 is observed during *in vitro* maturation (Lequarre *et al.*, 2004). Such deadenylation might be specifically controlled as a sequence related to the control of adenylation/deadenylation (Cytoplasmic Polyadenylation Element, CPE) is found in the 3'UTR region of the mRNA (Traverso, Lequarre and Donnay, unpublished). Such mRNA processing



can be related to the storage of transcripts for a further use during fertilization or early embryonic development. Indeed, maternal *Prx6* transcripts are observed up to the 5–8 cell stage, when the major onset of the embryonic gene expression occurs (Leyens *et al.*, 2004a).

The integrity of the junctions between the oocyte and the cumulus cells is necessary for the upregulation of *Prx6* in oocytes. On the contrary, oocytes induce the upregulation of *Prx6* transcription in the cumulus through paracrine factor(s) (Leyens *et al.*, 2004b). Conditioned medium enriched in GDF-9, an oocyte-specific protein, is able to mimic the effect of oocytes on cumulus cells, indicating that GDF-9 might be the, or one of the involved paracrine factors. The possible role of *Prx6* in oocyte maturation is still unknown. It can be acting as an antioxidant: The accumulation of glutathione during *in vitro* maturation would help the reduction of the enzyme, once oxidized. On the other hand, *Prx6* is known to have a phospholipase A2 activity and might therefore be involved in the synthesis of prostaglandins during the maturation of the cumulus-oocyte complex.

## 2. EMBRYO

None of the three knock-out mice already obtained for *Prx1*, *Prx2* or *Prx6* show evidence of lethality or troubles during embryo development (Lee *et al.*, 2003; Neumann *et al.*, 2003; Wang *et al.*, 2003). This contrasts with what is observed in homozygous *GPx4* deficient mice that are not viable. Indeed, *GPx4*  $-/-$  embryos die in utero at midgestation, which could be related to a role of this enzyme in organogenesis (Borchert *et al.*, 2006; Schneider *et al.*, 2006). However, this does not rule out a possible role for Prxs during development as their action shows some redundancy. Indeed, Prxs are expressed throughout development and some of them show specific patterns of regulation at specific moments. Moreover, their overexpression can prevent the induction of developmental anomalies (Peng *et al.*, 2004a; Peng *et al.*, 2004b). In this line, it will be interesting to study the impact of a double knock-out on gametogenesis and embryo development.

### 2.1. Preimplantation Embryo

Before implantation, mammalian embryos are exposed to reduced oxygen tension, both in the oviduct and in the uterus. Increased oxygen concentration induces developmental arrest *in vitro*, mainly during the major onset of the embryonic genome, known as maternal to embryonic transition (MET) (Guerin *et al.*, 2001). To explain such sensitivity to oxygen, it was first thought that early embryos did not express antioxidant defences and were thus particularly sensitive to oxidative stress. However it has now been proven that both non-enzymatic and enzymatic antioxidants are present, including Prxs (Guerin *et al.*, 2001; Harvey *et al.*, 1995; Leyens *et al.*, 2004a). The low oxygen tension in the genital tract is probably part of a mechanism aiming to fine tune the production of ROS involved in intracellular and intercellular signaling during preimplantation development (Agarwal *et al.*, 2005).

The expression pattern of the six mammalian *Prx* genes was evaluated at the mRNA level in single early *in vitro* produced bovine embryos by semi-quantitative PCR (Leyens *et al.*, 2004a). The pattern of expression is close to what is observed for most bovine antioxidant enzymes (Harvey *et al.*, 1995; Lequarre *et al.*, 2001). *Prx1* and *Prx5* transcripts are detected throughout development to the blastocyst stage. This may be related both to an important maternal pool of transcripts accumulated in the oocytes and to an early embryonic transcription. *Prx2*, *Prx3* and *Prx6* transcripts are not found around the 9–16 cell stage, corresponding to the MET in the bovine, and thus to the degradation of maternal transcripts in this species. *Prx4* transcripts are weakly detected, only in pools of embryos, from the 9–16 cell stage onwards, and are likely to play a minor role in early development. Only *Prx5* expression was studied at the protein level by immunohistochemistry (Leyens *et al.*, 2004a). Its expression is mainly mitochondrial in embryos and its early embryonic transcription from the 9–16 cell stage corresponds to the increase in embryo metabolism, including oxygen uptake, which makes it a good candidate to cope with ROS derived from the mitochondrial electron transport chain. However, modifying the oxygen tension during embryo culture did not seem to affect the level or pattern of *Prx* transcription (Leyens *et al.*, 2004a).

## 2.2. Post-implantation Embryo

In mouse, a consistently high level of expression of *Prx1* is detected in early stage embryonic tissues (7.5 to 10.5 dpc). From day 8.5 days of gestation, the transcripts suddenly decreased in embryonic bodies, except extra-embryonic membranes (Lee *et al.*, 1999). These results suggest that *Prx1* might be differently regulated by several transcription factors. Similarly, a consistently high level of expression of *Prx2* is detected in mouse embryonic tissues, both in the developing embryo and the extra-embryonic structure (age: 7 to 10 days), which suggests a role for the protein in embryonic development (Lim *et al.*, 1998). Those two enzymes could modulate hydrogen peroxide levels during the early embryonic periods via their peroxidase activity.

Interestingly, later in mouse development, at day 13.5, *Prx1* expression (mRNA and protein) in hindlimb interdigital tissues is down-regulated, which corresponds to the period when the interdigital cells are irreversibly committed to programmed cell death (Shan *et al.*, 2005). The pattern of expression of three other *Prxs* in the same tissue is unchanged: *Prx2* remains highly expressed, whereas *Prx3* and *Prx4* are not detected. However, the expression pattern of *Prx5* is similar to *Prx1*, exhibiting higher protein levels at day 12.5 than at 13.5. In contrast, *Prx6* expression is up-regulated at Day 13.5. *Prx1* expression is maintained when interdigital tissue cultures were manipulated to survive, but down regulated when the cells were permitted to die (Shan *et al.*, 2005). RNAi mediated silencing of *Prx1* expression increased the intracellular levels of ROS and activated the transcriptional factor NF- $\kappa$ B, possibly through a decrease in the NF- $\kappa$ B inhibitor I $\kappa$ B (Chu *et al.*, 2003). However, it does not induce interdigital cell death in culture, confirming that the

developmental fate of the interdigital tissues depends on a cocktail of death-inducing and survival factors that could initiate as well as inhibit interdigital cell death.

Another example indicating a possible role for Prxs in the control of ROS levels during development is observed in human Down Syndrome (DS) fetuses. Indeed, an underexpression of Prx2 occurs in DS fetal brains around 20 weeks of gestation (Sanchez-Font *et al.*, 2003). Such underexpression increases the sensitivity, *in vitro*, of neuroblastoma cells to oxidative stress, which suggests that the decreased expression of Prx2 may contribute to the altered redox state in DS leading to neurodegeneration (Sanchez-Font *et al.*, 2003).

### 2.3. Placenta

Prx6 and Prx4 are expressed by cytotrophoblast cells in human placenta (those cells form aggregates that invade the uterine wall and breach the maternal vessels in order to divert the flow of maternal blood to the placenta) (Hoang *et al.*, 2001). These cells are thus in close contact with maternal blood and its oxygen, and Prx6 is known to be highly expressed in organs exposed to high oxygen levels, such as skin and lung. Moreover, Prx6 can reduce the level of phospholipid hydroperoxides and may thus play a vital role in defending the plasma membrane against the effects of oxidative stress. The link between oxygen concentration and the expression of Prx6 in cytotrophoblast cells is confirmed by the fact that the expression of Prx6 is decreased 2 to 8 fold when those cells are cultured in hypoxic condition (2%O<sub>2</sub> versus 20%) (Hoang *et al.*, 2001).

Finally, Prx3 was recently found to be downregulated, together with SOD, at the mRNA and protein level, in human placental villous tissue collected after early pregnancy loss (Liu *et al.*, 2006).

### 2.4. Perinatal Period

Prxs are specifically regulated in lungs around birth. *Prx1* mRNA increase after birth in baboon and rat lungs (Das *et al.*, 2001; Kim *et al.*, 2001). However, in rat, the Prx1 protein already increases during late gestation, and after birth falls to adult levels. In contrast, Prx2 protein concentration is unchanged in the perinatal period, but *Prx2* mRNA increase after birth (Kim *et al.*, 2001). So, *Prx1* and *Prx2* seem developmentally regulated at the level of translational efficiency. As for *Prx2*, there is little change in *Prx6* expression in rat lungs during the prenatal period (low levels of both mRNA and protein), but a marked increase in expression is observed immediately after birth (at the mRNA and protein levels). Then protein levels remain stable, but enzymatic activity increases gradually after birth and reaches adult levels at 7–14 postnatal days, suggesting posttranslational modifications (Kim *et al.*, 2002). In conclusion, *Prx1*, but not *Prx2* seems inducible and is upregulated during the late-gestational preparation to the oxidative stress experienced by the lung at birth and during exposure to hyperoxia in the neonatal period (Kim *et al.*, 2001). The increased expression of *Prx6* at birth may be important for surfactant phospholipids

turnover related to the phospholipase A2 activity of the protein and for antioxidant defence based on its peroxidase function (Kim *et al.*, 2002; see also Chapter 14).

### 3. INSECTS

In *Drosophila melanogaster*, the glutathione reductase and selenium-containing glutathione peroxidases are absent as in other insects (Kanzok *et al.*, 2001), and a cysteine homolog of glutathione peroxidase in *D. melanogaster* is specifically reduced by thioredoxin (Maiorino *et al.*, 2007). The function of glutathione reductases is substituted by thioredoxin reductases, signifying the role of the thioredoxin system in the antioxidant defences in insects. The transcript levels of the *D. melanogaster* Prx family members were assessed by Northern blotting in RNA samples isolated from embryonic, larval, pupal and adult tissues (Radyuk *et al.*, 2001). Overall, mRNA levels are elevated in embryos for all five genes. However, the five Prx genes described in *D. melanogaster* show somewhat different patterns of transcript accumulation during development, suggesting different roles in tissue proliferation and differentiation. Two Prxs (Prx2540, a 1-Cys cytosolic Prx and Prx4783, a 2-Cys cytosolic Prx) show a high expression during embryonic development with a subsequent drop at the larval stage. The same Prx2540 is also expressed in imaginal discs (Rodriguez *et al.*, 2000). It has been thought of as a “housekeeping” gene. On the other hand, higher levels of Prx expression have been associated with cell proliferation and differentiation, and it can be induced. The abundance of the Prx4783 transcripts during embryogenesis suggests an important role in differentiation, at a stage where the rate of proliferation is high. The corresponding protein is abundant in early embryos (0–14h) (Rodriguez *et al.*, 2000). From this time, the protein decreases gradually until third instar larvae, before increasing from young pupae until adult. Similarly, the Prx genes present in the tsetse fly *Glossina morsitans* are expressed during development and some of them show expression variations (Munks *et al.*, 2005).

### 4. CONCLUSION

Data on the implication of Prxs in gametogenesis and development are scarce and fragmentary. However, the increasing evidence for key roles of ROS in both processes, and the ubiquitous expression of those enzymes throughout development, denote the interest to study the potential roles of Prxs in the control of development in animals.

### ACKNOWLEDGMENTS

The work of the authors is financially supported by the Fonds National de la Recherche Scientifique (FNRS) and by the Communauté française de Belgique-Actions de Recherche Concertées (ARC).

## REFERENCES

- Agarwal, A., Gupta S., Sharma R.K., 2005, Role of oxidative stress in female reproduction. *Reprod. Biol. Endocrinol.* **3**: 28.
- Baker, M.A., Aitken R.J., 2004, The importance of redox regulated pathways in sperm cell biology. *Mol. Cell. Endocrinol.* **216**: 47–54.
- Baker, M.A., Krutskikh A., Curry B.J., Hetherington L., Aitken R.J., 2005, Identification of cytochrome-b5 reductase as the enzyme responsible for NADH-dependent lucigenin chemiluminescence in human spermatozoa. *Biol. Reprod.* **73**: 334–342.
- Blondin, P., Coenen K., Sirard M.A., 1997, The impact of reactive oxygen species on bovine sperm fertilizing ability and oocyte maturation. *J. Androl.* **18**: 454–460.
- Borchert, A., Wang C.C., Ufer C., Schiebel H., Savaskan N.E., Kühn, H., 2006, The role of phospholipid hydroperoxide glutathione peroxidase (GPx4) isoforms in murine embryogenesis. *J. Biol. Chem.* **281**: 19655–19664.
- Chaube, S.K., Prasad P.V., Thakur S.C., Shrivastav T.G., 2005, Hydrogen peroxide modulates meiotic cell cycle and induces morphological features characteristic of apoptosis in rat oocytes cultured in vitro. *Apoptosis* **10**: 863–874.
- Chu, S.H., Lee-Kang J., Lee K.H., Lee, K., 2003, Roles of reactive oxygen species, NF-kappaB, and peroxiredoxins in glycochenodeoxycholic acid-induced rat hepatocytes death. *Pharmacology* **69**: 12–19.
- Das, K.C., Pahl P.M., Guo X.L., White, C.W., 2001, Induction of peroxiredoxin gene expression by oxygen in lungs of newborn primates. *Am. J. Respir. Cell. Mol. Biol.* **25**: 226–232.
- Dekel, N., 2005, Cellular, biochemical and molecular mechanisms regulating oocyte maturation. *Mol. Cell. Endocrinol.* **234**: 19–25.
- Ellederova, Z., Halada, P., Man, P., Kubelka, M., Motlik, J., Kovarova, H., 2004, Protein patterns of pig oocytes during in vitro maturation. *Biol. Reprod.* **71**: 1533–1539.
- Fouchecourt, S., Metayer S., Locatelli A., Dacheux F., Dacheux J.L., 2000, Stallion epididymal fluid proteome: qualitative and quantitative characterization; secretion and dynamic changes of major proteins. *Biol. Reprod.* **62**: 1790–1803.
- Guerin, P., El Mouatassim, S., Menezo, Y., 2001, Oxidative stress and protection against reactive oxygen species in the pre-implantation embryo and its surroundings. *Hum. Reprod. Update* **7**: 175–189.
- Harvey, M.B., Arcellana-Panlilio, M.Y., Zhang, X., Schultz, G.A., Watson, A.J., 1995, Expression of genes encoding antioxidant enzymes in preimplantation mouse and cow embryos and primary bovine oviduct cultures employed for embryo coculture. *Biol. Reprod.* **53**: 532–540.
- Hinton, B.T., Palladino, M.A., Rudolph, D., Labus, J.C., 1995, The epididymis as protector of maturing spermatozoa. *Reprod. Fertil. Dev.* **7**: 731–745.
- Hoang, V.M., Foulk R., Clauser, K., Burlingame, A., Gibson, B.W., Fisher, S.J., 2001, Functional proteomics: examining the effects of hypoxia on the cytotrophoblast protein repertoire. *Biochemistry* **40**: 4077–4086.
- Jervis, K.M., Robaire, B., 2001, Dynamic changes in gene expression along the rat epididymis. *Biol. Reprod.* **65**: 696–703.
- Kanzok, S.M., Fechner, A., Bauer, H., Ulschmid, J.K., Muller, H.M., Botella-Munoz, J., Schneuwly, S., Schirmer, R., Becker, K., 2001, Substitution of the thioredoxin system for glutathione reductase in *Drosophila melanogaster*. *Science* **291**: 643–646.
- Kim, H.S., Kang, S.W., Rhee, S.G., Clerch, L.B., 2001, Rat lung peroxiredoxins I and II are differentially regulated during development and by hyperoxia. *Am J Physiol Lung Cell. Mol. Physiol.* **280**: L1212–L1217.
- Kim, H.S., Pak, J.H., Gonzales, L.W., Feinstein, S.I., Fisher, A.B., 2002, Regulation of 1-cys peroxiredoxin expression in lung epithelial cells. *Am. J. Respir. Cell. Mol. Biol.* **27**: 227–233.
- Lee, K., Park, J.S., Kim, Y.J., Soo Lee, Y.S., Sook Hwang, T.S., Kim, D.J., Park, E.M., Park, Y.M., 2002, Differential expression of Prx I and II in mouse testis and their up-regulation by radiation. *Biochem. Biophys. Res. Commun.* **296**: 337–342.

- Lee, T.H., Kim, S.U., Yu, S.L., Kim, S.H., Park do, S., Moon, H.B., Dho, S.H., Kwon, K.S., Kwon, H.J., Han, Y.H., Jeong, S., Kang, S.W., Shin, H.S., Lee, K.K., Rhee, S.G., Yu, D.Y., 2003, Peroxiredoxin II is essential for sustaining life span of erythrocytes in mice. *Blood* **101**: 5033–5038.
- Lee, T.H., Yu, S.L., Kim, S.U., Lee, K.K., Rhee, S.G., Yu, D.Y., 1999, Characterization of mouse peroxiredoxin I genomic DNA and its expression. *Gene* **239**: 243–250.
- Lequarre, A.S., Feugang, J.M., Malhomme, O., Donnay, I., Massip, A., Van Langendonck, A., 2001, Expression of Cu/Zn and Mn superoxide dismutases during bovine embryo development: influence of in vitro culture. *Mol. Reprod. Dev.* **58**: 45–53.
- Lequarre, A.S., Traverson, J.M., Marchandise, J., Donnay, I., 2004, Poly(A) RNA is reduced by half during bovine oocyte maturation but increases when meiotic arrest is maintained with CDK inhibitors. *Biol. Reprod.* **71**: 425–431.
- Leyens, G., Donnay, I., Knoops, B., 2003, Cloning of bovine peroxiredoxins-gene expression in bovine tissues and amino acid sequence comparison with rat, mouse and primate peroxiredoxins. *Comp. Biochem. Physiol. B. Biochem. Mol. Biol.* **136**: 943–955.
- Leyens, G., Knoops, B., Donnay, I., 2004a, Expression of peroxiredoxins in bovine oocytes and embryos produced in vitro. *Mol Reprod Dev* **69**: 243–251.
- Leyens, G., Verhaeghe, B., Landtmeters, M., Marchandise, J., Knoops, B., Donnay, I., 2004b, Peroxiredoxin 6 is upregulated in bovine oocytes and cumulus cells during in vitro maturation: role of intercellular communication. *Biol. Reprod.* **71**: 1646–1651.
- Lim, M.J., Chae, H.Z., Rhee, S.G., Yu, D.Y., Lee, K.K., Yeom, Y.I., 1998, The type II peroxiredoxin gene family of the mouse: molecular structure, expression and evolution. *Gene* **216**: 197–205.
- Liu, A.X., Jin, F., Zhang, W., Zhou, T.H., Zhou, C.Y., Yao, W.M., Qian, Y.L., and Huang, H.F., 2006, Proteomic Analysis on the Alteration of Protein Expression in the Placental Villous Tissue of Early Pregnancy Loss. *Biol. Reprod.*, May 31 (Epub ahead of print).
- MacLeod, J. 1943, The role of oxygen in the metabolism and motility of human spermatozoa. *Am. J. Physiol.* **138**: 512–518.
- Maiorino, M., Bosello, V., Ursini, F., Foresta, C., Garolla, A., Scapin, M., Sztajer, H., Flohé, L., 2003, Genetic variations of gpx-4 and male infertility in humans. *Biol. Reprod.* **68**: 1134–1141.
- Maiorino, M., Ursini, F., Bosello, V., Toppo, S., Toeatto, S. C., Mauri, P., Becker, K., Roveri, A., Bulato, C., Benazzi, L., de Palma, A., and Flohé, L., 2007, The thioredoxin specificity of Drosophila GPx: a paradigm for a peroxiredoxin-like mechanism of many glutathione peroxidases. *J. Mol. Biol.* **365**: 1033–1046.
- Munks, R.J., Sant'Anna, M.R., Grail, W., Gibson, W., Igglesden, T., Yoshiyama, M., Lehane, S.M., Lehane, M.J., 2005, Antioxidant gene expression in the blood-feeding fly *Glossina morsitans morsitans*. *Insect. Mol. Biol.* **14**: 483–491.
- Neumann, C.A., Krause, D.S., Carman, C.V., Das, S., Dubey, D.P., Abraham, J.L., Bronson, R.T., Fujiwara, Y., Orkin, S.H., Van Etten, R.A., 2003, Essential role for the peroxiredoxin Prx1 in erythrocyte antioxidant defence and tumour suppression. *Nature* **424**: 561–565.
- O'Flaherty, C., de Lamirande, E., and Gagnon, C., 2006, Reactive oxygen species modulate independent protein phosphorylation pathways during human sperm capacitation. *Free Radic. Biol. Med.* **40**: 1045–1055.
- Okado-Matsumoto, A., Matsumoto, A., Fujii, J., Taniguchi, N., 2000, Peroxiredoxin IV is a secretable protein with heparin-binding properties under reduced conditions. *J. Biochem. (Tokyo)* **127**: 493–501.
- Pasqualotto, E. B., Agarwal, A., Sharma, R.K., Izzo, V.M., Pinotti, J.A., Joshi, N.J., Rose B.I., 2004, Effect of oxidative stress in follicular fluid on the outcome of assisted reproductive procedures. *Fertil. Steril.* **81**: 973–976.
- Peng, Y., Yang, P.H., Guo, Y., Ng, S.S., Liu, J., Fung, P.C., Tay, D., Ge, J., He, M.L., Kung, H.F., Lin, M.C., 2004a, Catalase and peroxiredoxin 5 protect *Xenopus* embryos against alcohol-induced ocular anomalies. *Invest. Ophthalmol. Vis. Sci.* **45**: 23–29.
- Peng, Y., Yang, P.H., Ng, S.S., Lum, C.T., Kung, H.F., Lin, M.C., 2004b, Protection of *Xenopus laevis* embryos against alcohol-induced delayed gut maturation and growth retardation by peroxiredoxin 5 and catalase. *J Mol Biol* **340**: 819–827.

- Radyuk, S.N., Klichko, V.I., Spinola, B., Sohal, R.S., Orr, W.C., 2001, The peroxiredoxin gene family in *Drosophila melanogaster*. *Free Radic. Biol. Med.* **31**: 1090–1100.
- Rhee, S.G., Kang, S.W., Jeong, W., Chang, T.S., Yang, K.S., Woo, H.A., 2005, Intracellular messenger function of hydrogen peroxide and its regulation by peroxiredoxins. *Curr. Opin. Cell. Biol.* **17**: 183–189.
- Rodriguez, J., Agudo, M., Van Damme, J., Vandekerchove, J., Santaren, J.F., 2000, Polypeptides differentially expressed in imaginal discs define the peroxiredoxin family of genes in *Drosophila*. *Eur. J. Biochem.* **267**: 487–497.
- Roveri, A., Ursini, F., Flohe, L., and Maiorino, M., 2001, PHGPx and spermatogenesis. *Biofactors* **14**: 213–222.
- Sanchez-Font, M.F., Sebastia, J., Sanfeliu, C., Cristofol, R., Marfany, G., Gonzalez-Duarte, R., 2003, Peroxiredoxin 2 (PRX2), an antioxidant enzyme, is under-expressed in Down syndrome fetal brains. *Cell. Mol. Life Sci.* **60**: 1513–1523.
- Sasagawa, I., Matsuki, S., Suzuki, Y., Iuchi, Y., Tohya, K., Kimura, M., Nakada, T., Fujii, J., 2001, Possible involvement of the membrane-bound form of peroxiredoxin 4 in acrosome formation during spermiogenesis of rats. *Eur. J. Biochem.* **268**: 3053–3061.
- Schneider, M., Vogt-Weisenhorn, D. M., Seiler, A., Bornkamm, G. W., Brielmeier, M. and Conrad, M., 2006, Embryonic expression profile of phospholipid hydroperoxide glutathione peroxidase. *Gene Expr. Patterns* **6**: 489–494.
- Seligman, J., Newton, G.L., Faney, R.C., Shalgi, R., Kosower, N.S., 2005, Nonprotein thiols and disulfides in rat epididymal spermatozoa and epididymal fluid: role of gamma-glutamyl-transpeptidase in sperm maturation. *J. Androl.* **26**: 629–637.
- Shan, S.W., Tank, M.K., Cai, D.Q., Chui, Y.L., Chow, P.H., Grotewold, L., Kee, L.L., 2005, Comparative proteomic analysis identifies protein disulfide isomerase and peroxiredoxin 1 as new players involved in embryonic interdigital cell death. *Dev. Dyn.* **233**: 266–281.
- Takami, M., Preston, S.L., Toyloy, V.A., Behrman, H.R., 1999, Antioxidants reversibly inhibit the spontaneous resumption of meiosis. *Am. J. Physiol.* **276**: E684–E688.
- Tosic, J., Walton, A., 1946, Formation of hydrogen peroxide by spermatozoa and its inhibitory effect on respiration. *Nature* **158**: 485.
- Tramer, F., Rocco, F., Micali, F., Sandri, G., Panfili, E., 1998, Antioxidant systems in rat epididymal spermatozoa. *Biol. Reprod.* **59**: 753–788.
- Ursini, F., Heim, S., Kiess, M., Maiorino, M., Roveri, A., Wissing, J., Flohe, L., 1999, Dual function of the selenoprotein PHGPx during sperm maturation. *Science* **285**: 1393–1396.
- Wang, X., Phelan, S.A., Forsman-Semb, K., Taylor, E.F., Petros, C., Brown, A., Lerner, C.P., Paigen, B., 2003, Mice with targeted mutation of peroxiredoxin 6 develop normally but are susceptible to oxidative stress. *J. Biol. Chem.* **278**: 25179–25190.
- Wiener-Megnazi, Z., Vardi, L., Lissak, A., Shinzer, S., Reznick, A.Z., Ishai, D., Lahav-Baratz, S., Shiloh, H., Koifman, M., Dirnfeld, M., 2004, Oxidative stress indices in follicular fluid as measured by the thermochemiluminescence assay correlate with outcome parameters in in vitro fertilization. *Fertil. Steril.* **82** Suppl 3: 1171–1176.
- Zini, A., Fisher, M.A., Mak, V., Phang, D., Jarvi, K., 2002, Catalase-like and superoxide dismutase-like activities in human seminal plasma. *Urol. Res.* **30**: 321–323.
- Zubkova, E.V., Robaire, B., 2004, Effect of glutathione depletion on antioxidant enzymes in the epididymis, seminal vesicles, and liver and on spermatozoa motility in the aging brown Norway rat. *Biol. Reprod.* **71**: 1002–1008.

## CHAPTER 17

# PEROXIREDOXINS IN THE CENTRAL NERVOUS SYSTEM

FUMIYUKI HATTORI AND SHINZO OIKAWA

*Asubio Pharma Co. Ltd. Research park, Institute of Integrated Medical Research Keio University School of Medicine, Tokyo, Japan*

**Abstract:** Oxidative stress is considered one of the causative pathomechanisms of nervous system diseases such as Alzheimer's disease, Parkinson's disease, amyotrophic lateral sclerosis, stroke and excitotoxicity. The basal expression of six different peroxiredoxin (Prx) isozymes show distinct distribution profiles in different brain regions and different cell types. PrxI and VI are expressed in glial cells but not in neurons; while PrxII, III, IV and V are expressed in neurons. Various diseases or models show altered expression levels of these isozymes, such as by upregulation of PrxI, II and VI and downregulation of PrxIII. Thioredoxin (Trx)I mRNA is distributed widely in the rat brain. This distribution pattern may reflect the specific functions of these isozymes. Recently, the neuroprotective roles of Prx III and V against ibotenate-induced-excitotoxicity were reported by two independent groups. Adenovirus transduction of PrxIII eliminated protein nitration and prevented gliosis caused by direct infusion of ibotenate. Systemic administration of recombinant PrxV diminished brain lesions in animals treated with ibotenate. In this chapter, we review the causative mechanisms of oxidative stress in neurodegenerative diseases, as well as describe the basal and disease-induced changes in Prxs/Trxs/Trx reductases expression levels and neuroprotective roles of Trxs and Prxs as demonstrated in overexpression models

**Keywords:** Neurodegeneration, Oxidative stress, Alzheimer's disease, Parkinson's disease, Amyotrophic lateral sclerosis, Stroke, Excitotoxicity

## 1. INTRODUCTION: OXIDATIVE STRESS AND THE NERVOUS SYSTEM

Oxidative stress is considered one of the causative pathomechanisms of nervous system diseases.

### 1.1. Alzheimer's Disease (AD)

Histopathologically, Alzheimer's disease (AD) is characterized by synaptic loss, nerve cell loss (mostly in the cerebral cortex, hippocampus and amygdala), extracellular



deposition of  $\beta$ -amyloid (A $\beta$ ) protein (forming senile plaques) and intracellular precipitation of hyperphosphorylated tau protein (forming neurofibrillary tangles). The exact biochemical mechanism of AD is still unknown, but much attention is given to the possible implication of oxidative stress in its development. Age is a strong risk factor for AD, and several studies show logarithmic age-dependent increases in oxidized proteins, lipids and DNA in AD patients (Floyd and Hensley, 2002). Oxidizing conditions cause protein cross-linking and aggregation of A $\beta$  peptides (Dyrks *et al.*, 1993) and also contribute to aggregation of tau protein (Troncoso *et al.*, 1993) and other cytoskeletal proteins (Bellomo *et al.*, 1990). Significant increases of 8-hydroxy-2'-deoxyguanosine (8-OHdG) in nuclear DNA (nDNA) and mitochondrial DNA (mtDNA) isolated from three cortical areas and cerebellum of AD patients were found compared with the control. These levels were much higher in mtDNA than in nDNA, reflecting the high susceptibility of mitochondria to oxidative stress (Mecocci *et al.*, 1994). In AD brains, lipid peroxidation was assessed quantitatively by measuring the levels of thiobarbituric acid reactive substance (TBARS), 4-hydroxy-2-nonenal (HNE), malondialdehyde (MDA), lipid hydroperoxides, and isoprostanes. Increased levels of 3-nitrotyrosine were found in neurons containing neurofibrillary tangles (Su *et al.*, 1997) and increased amounts of carbonyl groups were found in AD brains by chemiluminescence assay (McIntosh *et al.*, 1997).

### 1.2. Parkinson's Disease (PD)

Parkinson's disease (PD) is a neurodegenerative disorder characterized by a dramatic loss of dopaminergic neurons in the substantia nigra. Among the many pathogenic mechanisms thought to contribute to the demise of these cells, dopamine-dependent oxidative stress has classically taken center stage due to extensive experimental evidence showing that dopamine-derived reactive oxygen species (ROS) and oxidized dopamine metabolites are toxic to nigral neurons. Further evidence for the role of oxidative stress in PD patients comes from studies on the selective toxicity against the substantia nigra of 1-methyl-4-phenyl-1,2,3,6-tetrahydropyridine (MPTP), which induces Parkinson-like symptoms in primates. MPTP acts through its metabolite MPP<sup>+</sup> to inhibit Complex I of the mitochondrial respiratory chain. Post-mortem studies on PD brains have demonstrated a disease-specific and drug-independent defect of mitochondrial Complex I in the substantia nigra of PD patients (Hattori *et al.* 1991; Burkhardt *et al.* 1993). There is also evidence of increased lipid peroxidation in the PD brain (Yoritaka *et al.*, 1996). Furthermore, there is a 10-fold increase in cholesterol lipid hydroperoxide, a marker of lipid peroxidation, in the PD substantia nigra compared with control subjects (Dexter *et al.*, 1994). PD is also associated with increased oxidative damage to DNA, with marked increase in 8-OHdG in the caudate nucleus and substantia nigra (Beal, 1995).

### 1.3. Amyotrophic Lateral Sclerosis (ALS)

Amyotrophic lateral sclerosis (ALS) is a progressive, neurodegenerative disease characterized by gradual degeneration of motor neurons in the cortex, brainstem and

spinal cord. The cause of neuronal death in sporadic ALS is not known. However, in approximately 10% of all ALS cases, the disease is inherited. Familiar ALS (FALS) shows autosomal dominant inheritance and very high penetration. About 20% of FALS cases are associated with point mutations and low activity of CuZnSOD (superoxide dismutase, SOD1) (Rosen *et al.*, 1993). Other studies reported an increase in mitochondrial MnSOD (SOD2) protein and activity. There is evidence of oxidative damage to DNA in ALS: Increased levels of 8-OHdG were found in plasma, urine, and cerebrospinal fluid of ALS patients. As far as protein oxidation is concerned, a large increase in protein carbonyls was found both in frontal and motor cortex (Ferrante *et al.*, 1997). In addition, there is substantial evidence for increased protein nitration in ALS, with increased immunocytochemical staining for 3-nitrotyrosine in spinal cord motor neurons of both sporadic and FALS patients (Beal *et al.*, 1997).

#### 1.4. Stroke

Stroke is the main cause of disability and mortality in Western countries. Ischemic stroke accounts for about 75% of all cases, while hemorrhagic stroke is responsible for almost 15% of all strokes. It has been also estimated that up to 30% of all ischemic strokes will eventually undergo hemorrhagic transformation. Brain ischemia and especially post-stroke ischemia and reperfusion, are associated with free radical-mediated reactions that could potentially lead to neuronal death (Alexandrova *et al.*, 2004). Extensive evidence from experimental studies suggests the involvement of free radical generation and oxidative injury in the pathogenesis of stroke. Several sources of free radicals have been proposed, including inflammatory cells, xanthine oxidase, cyclooxygenases, and mitochondria (Piantadosi and Zhang, 1996). The large increases in glutamate and aspartate that accompany ischemia may contribute to free radical generation by excitotoxic mechanisms (Morimoto *et al.*, 1996). Plasma levels of 8-OHdG were found to be increased in an animal model of ischemic stroke, which correlated significantly with brain content of 8-OHdG (Nagayama *et al.*, 2000). A similar DNA oxidative damage was reported in humans; high plasma concentrations of 8-OHdG were found after ischemic stroke, which correlated significantly with brain content of 8-OHdG (Liu *et al.*, 2004). Several studies also provided evidence for lipid peroxidation in cerebral ischemia, with high levels of TBARS and fluorescent lipid peroxidation products in brain and peripheral tissues after ischemia (Sakamoto *et al.*, 1991; White *et al.*, 1993; Demirkaya *et al.*, 2001).

#### 1.5. Excitotoxicity

Glutamate mediates excitatory synaptic transmission through the activation of ionotropic glutamate receptors sensitive to NMDA (N-methyl-D-aspartate), AMPA ( $\alpha$ -amino-3-hydroxy-5-methyl-4-isoxazolepropionic acid), or kainate. This excitatory transmission mediates normal information processing and neuronal plasticity. Interruption of blood supply to the brain causes deprivation of oxygen and

glucose that are utilized to produce energy. Impaired energy increases pre-synaptic glutamate release through membrane depolarization with subsequent activation of the voltage-gated  $\text{Ca}^{2+}$  channel. It also interferes with the re-uptake of glutamate (primarily into astrocytes), which results in abnormal accumulation of synaptic glutamate. Excess and sustained activation of the ionotropic glutamate receptors causes cytosolic and mitochondrial calcium overload and results in neuronal death. This type of cell death is also called delayed neuronal death, because of persistence of a chain of death-related events after acute injury.

## **2. EXPRESSION OF PEROXIREDOXIN/THIOREDOXIN REDUCTASE SYSTEM IN THE NERVOUS SYSTEM**

### **2.1. Basal Expression of Prxs in the CNS**

According to the recent work by Jin and colleagues the expression patterns of the six different Prx isozymes show distinct distribution profiles in different brain regions and different cell types (Jin *et al.*, 2005). PrxI immunoreactivity was located mainly in the nuclei of oligodendrocytes and microglia in the mouse brain, suggesting that PrxI regulates signal transduction rather than acting as an antioxidant.

PrxII immunoreactivity was principally found in neurons of grey matter, such as the hippocampus, cerebral cortex, and thalamus. A previous immunohistochemical study reported that PrxII is expressed exclusively in neurons. In contrast, astrocytes, oligodendrocytes, ependymal cells, and microglia did not show PrxII immunostaining, except in the basal ganglia where some ependymal cells were weakly stained (Sarafian *et al.*, 1999). PrxII immunoreactivity was detected in the cytosol of most neurons as well as in the nuclei of the medial habenular neurons. This implies that PrxII plays a role in the nuclei of specific neurons in addition to antioxidant activity.

PrxIII formed a punctate pattern in the cytoplasm of neurons. We also reported a relatively weak punctate or granular pattern of PrxIII immunoreactivity in the cytoplasm of neurons in the CA1-2 region compared with those in the CA3 region. This finding was not due to a low level of PrxIII in the mitochondria, but rather to the small numbers of neuron-like cells present in the CA1-2 and dentate gyrus regions, and the small number of mitochondria present in these cells (Hattori *et al.*, 2003). This expression pattern of PrxIII protein in the hippocampus is similar to that of TrxII protein and that of TrxI mRNA.

PrxIV immunoreactivity was observed in both neurons and oligodendrocytes in the mouse brain. PrxIV protein is localized in the cytoplasm of cells (Wood *et al.*, 2003). PrxIV immunoreactivity is localized in the cytoplasm of neurons, as well as in the nuclei of oligodendrocytes. PrxIV may possess antioxidant activity in neurons and may play a role in the nuclei of neuroglial cells in the brain.

PrxV immunolabeling was observed in neurons. PrxV immunoreactivity was evenly dispersed in the CA3 and CA2 regions, in contrast to PrxIII immunoreactivity. PrxV may be targeted intracellularly to mitochondria, peroxisomes, and the

cytosol, whereas PrxIII proteins are located in the mitochondria (Watabe *et al.*, 1997; Seo *et al.*, 2000). It is possible that the differences in subcellular localization of PrxV and III may explain the differences in their immunoreactivities in the CA2 region of the hippocampus.

PrxVI immunoreactivity was identified in mouse brain astrocytes and oligodendrocytes. Although PrxVI is known to be cytosolic (Wood *et al.*, 2003), PrxVI protein was also found in the nuclei of astrocytes and oligodendrocytes. A few PrxVI immunoreactive cells, astrocytes and oligodendrocytes were found in the white matter, such as the corpus callosum and fimbria of the hippocampus, whereas most cells including oligodendrocytes, were immunoreactive for PrxI.

Table 1. Comparison of immunoreactive patterns and intracellular distribution of Prx isoforms in mouse brain.

Cell types	PrxI	PrxII	PrxIII	PrxIV	PrxV	PrxVI
Neurons	–	+ c, n*	+ m	+ c	+ c, m, p	–
Neuroglia						
Oligodendrocytes	++ n	–	–	++ n	–	+ c, n
Astrocytes	–	–	–	–	–	+ c, n
Microglia	+ n	–	–	–	–	–

(++) High, (+) low to moderate, (–) not c: cytosol, n: nuclei, m: mitochondria, p: \* expression was observed in only habenular.

## 2.2. Basal Expression of Trxs in the CNS

TrxI mRNA is widely expressed in rat brain, including preoptic area, CA3/CA4 region of hippocampal formation, dentate gyrus, paraventricular nucleus of the hypothalamus, arcuate nucleus, substantia nigra pars compacta, locus coeruleus, ependyma of the 4th ventricle, and epithelial cells of the choroid plexus, especially in regions of high metabolic activity, such as substantia nigra and subthalamic nuclei (Patenaude *et al.*, 2005). Thioredoxin mRNA is expressed in nerve cells. The immunohistochemical localization of thioredoxin in the brain has not been updated in detail, and thus we have to rely on the limited information in certain brain regions. Immunohistochemical analysis of TrxI in human brain showed positive TrxI-like staining in white matter astrocytes (Asahina, Yamada *et al.*, 1998). A more intense TrxI expression was also found in the white matter than in the grey matter, as assessed by semiquantitative reverse-transcription polymerase chain reaction (Asahina *et al.*, 1998). The same study also detected TrxI expression in peripheral nerves and Schwann cells, in agreement with a previous report (Stemme *et al.*, 1985).

The mitochondrial isoform, TrxII, is abundantly and widely distributed in the rat brain (Rybnikova *et al.*, 2000). Interestingly, the expression levels of mRNA

and protein are inconsistent in some regions. For example, mRNA levels in CA1/4 and internal granular layer are quite high but no immunohistochemical signals were observed. The brain regions with highest expression at mRNA and protein levels include the olfactory bulb, frontal cortex, hippocampus, some hypothalamic and thalamic nuclei, cerebellum and brainstem nuclei (Rybnikova *et al.*, 2000). TrxII mRNA-expressing cells appeared to be neurons and the expression pattern of TrxII tends to be associated with brain regions known to produce high levels of ROS (Rybnikova *et al.*, 2000).

### 2.3. Basal Expression of Thiredoxin Reductases in the CNS

Little information is available on the expression of thiredoxin reductase (TrxR) isoforms in the CNS. Strong TrxR and TrxI immunoreactivity is detected in the cytoplasm of neuronal rat cells (Rozell *et al.*, 1985), e.g. Schwann cells and at the nodes of Ranvier (Stemme *et al.*, 1985). TrxR I and TrxI accumulate in the dilated axon following mechanical nerve injury, and this accumulation can be blocked by microtubule-destabilizing agents, suggesting anterograde and retrograde transport of these proteins in axons (Stemme, *et al.*, 1985).

### 2.4. Prxs Induction and Reduction in the CNS

A number of studies have shown that several Prx isoforms can be induced in the brain by various insults, suggesting neuroprotective function(s) for these proteins in the CNS. High PrxI levels are reported specifically in glia cells following hemorrhagic and excitotoxic stress (Nakaso *et al.*, 1999; Nakaso *et al.*, 2000). Exposure to hemin, a strong prooxidant, also induced PrxI in SH-SY5Y neuronal cells (Nakaso *et al.*, 2003). Similar to TrxI, induction of PrxI appears to involve the transcription factor Nfr2 (Nakaso *et al.*, 2003). We also showed that mitochondrial PrxIII mRNA levels diminished in response to ibotenate-mediated excitotoxicity, in contrast to Cu/ZnSOD and catalase mRNA levels, which did not change significantly (Hattori *et al.*, 2003). PrxIII expression was also low in brain regions known to be specifically affected in AD, Down's syndrome (DS) and PD (Kim *et al.*, 2001; Krapfenbauer *et al.*, 2003). Furthermore, PrxIII protein levels in the cerebellum correlate inversely with age in human (Krapfenbauer *et al.*, 2003). Similarly, a proteomic comparison of old *versus* young human brain samples revealed lower PrxII protein levels in the elderly (Chen *et al.*, 2003). These apparent deficits in Prx antioxidant defenses might contribute to increased oxidative stress in the aging brain.

### 2.5. Altered Expression of Prxs in Neurodegenerative Diseases

Recent studies identified aberrant patterns of Prx expression in the CNS of patients with neurodegenerative disorders. A proteomic study reported brain region- and disease-specific increases of PrxII and PrxI, and, in contrast, decreases of mitochondrial PrxIII in AD and DS brains (Kim *et al.*, 2001). Another proteomic study

found significantly high PrxII levels in the frontal cortexes of DS, AD and PD, whereas PrxIII was decreased in frontal cortexes of DS and PD; PrxVI was significantly high only in PD frontal cortex (Krapfenbauer *et al.*, 2003). High PrxII and PrxVI levels were also found in Pick's disease (Krapfenbauer *et al.*, 2003). In contrast to PrxII, low PrxIII levels were reported in AD, DS and Pick's disease (Kim *et al.*, 2001; Krapfenbauer *et al.*, 2003). The decrease was significant in the thalamus and occipital cortex in AD, and in the frontal cortex in DS (Kim *et al.*, 2001), and in whole brain of patients with Pick's disease (Krapfenbauer *et al.*, 2003). The interpretation of these data is at best speculative. The high levels of these Prx subtypes are thought to reflect an antioxidant defense up-regulation in response to increased ROS production, or glial cell proliferation in the case of PrxI. Whether the PrxIII deficits reflect mitochondrial impairment, down-regulation of PrxIII expression or simply cell loss is not known at present. Two-dimensional gel and Western blot analysis of Prx proteins in brains of patients with prion-associated sporadic Creutzfeldt-Jacob disease (sCJD) showed low levels of PrxI but high levels of PrxVI in the frontal cortex, without significant changes in PrxII and PrxIII isoforms (Krapfenbauer *et al.*, 2002). In agreement with these observations in sCJD, a high expression of PrxVI mRNA was also observed in mouse brain spongiform degeneration induced by intracerebral prion injection (Kopacek *et al.*, 2000). PrxVI up-regulation was limited to astrocytes in the affected tissues, and no significant changes in PrxI and PrxIII expression levels were detected. Whether PrxVI up-regulation reflects increased oxidative stress associated with prion infection and whether it plays a role in CJD pathogenesis remains to be determined. From the comparative proteome analysis, it was found that the levels of PrxV decreased in the corticobasal degenerating brain compared with non-demented controls (Chen *et al.*, 2005). All studies using human samples listed below employed a proteomic approach, and all of them found only one spot(s) corresponding to one peroxiredoxin(s). Under oxidative stress conditions, peroxiredoxins are oxidized at the active site Cys residue to cysteine sulphenic acid (-Cys-SOH), which is readily oxidized to Cys-SO<sub>2</sub>H by further oxidation. Since Cys-SO<sub>2</sub>H is not reduced by DTT, over-oxidized Prx can be detected by two dimensional gel electrophoresis. In this context, there is a need for further studies to analyze both oxidized and reduced spots of each Prxs in order to understand the functional states of Prxs (Yang *et al.*, 2002).

## 2.6. Trx Induction in the CNS

A variety of hormones and non-toxic chemicals, as well as stress conditions including infectious agents, are reported to induce TrxI expression, as reviewed elsewhere (Powis and Montfort, 2001). An ADF/TRX immunohistochemistry study in gerbil brain during reperfusion following transient cerebral ischemia showed widespread immunoreactivity in non-ischemic control brain regions, including the ependyma, tanycytes, endothelial cells as well as subcommisural organs, and weak staining in neuronal cell bodies (Tomimoto *et al.*, 1993). During reperfusion, and

Table 2. Expression of Prxs in the CNS.

	Pathology, experimental system, stress, insult	Expression	Level	Species	Methods	Reference
Prx-1	blood intracranial injection	around hemorrhagic region microglia (acute) astrocytes (chronic)	+	rat	Western blot	Nakaso K, 2000
Prx-1	blood intracranial injection	neurons and oligodendrocytes	=	rat	Western blot	Nakaso K, 2000
Prx-1	Alzheimer's disease	temporal and occipital cortex, thalamus	+	human	proteomics	Kim SH, 2001
Prx-1	Down's Syndrome	thalamus	+	human	proteomics	Kim SH, 2001
Prx-1	CJD (sporadic)	frontal cortex (study limited to frontal cortices)	-	human	proteomics	Krapfenbauer K, 2002
Prx-1	Alzheimer's Down's Syndrome, Pick's disease	frontal cortex (study limited to frontal cortex and cerebellum)	=	human	proteomics	Krapfenbauer K, 2003
Prx-1	intracerebral prion injection	brain	=	mouse	Northern blot	Kopacek J, 2000
Prx-2	aging	brain	-	human	proteomics	Chen W, 2003
Prx-2	Alzheimer's disease	thalamus	+	human	proteomics	Kim SH, 2001
Prx-2	Down's Syndrome	cerebellum, temporal cortex, thalamus	+	human	proteomics	Kim SH, 2001
Prx-2	Alzheimer's, Down's Syndrome, Pick's disease	frontal cortex (study limited to frontal cortex and cerebellum)	-	human	proteomics	Krapfenbauer K, 2003
Prx-2	sCJD	frontal cortex, cerebellum (study limited to frontal cortices)	=	human	proteomics	Krapfenbauer K, 2002
Prx-3	Alzheimer's disease	occipital cortex, thalamus	-	human	proteomics	Kim SH, 2001
Prx-3	Down's Syndrome	frontal cortex	-	human	proteomics	Kim SH, 2001

Prx-3	Down's Syndrome, Pick's disease	frontal cortex (study limited to frontal cortex and cerebellum)	-	human	proteomics	Krapfenbauer K, 2003
Prx-3	ibotenate microinjection in hippocampus	hippocampus	-	rat	real time PCR	Hattori F, 2003
Prx-3	intracerebral prion injection	brain	=	mouse	Northern blot	Kopacek J, 2000
Prx-3	sCJD	frontal cortex, cerebellum (study limited to frontal cortices)	=	human	proteomics	Krapfenbauer K, 2002
Prx-3	aging	cerebellum (study limited to frontal cortex and cerebellum)	-	human	proteomics	Chen W, 2003
Prx-5	Corticobasal degeneration	Whole temporal and parietal lobes	-	human	proteomics	Chen W, 2005
Prx-6	Pick's disease	frontal cortex (study limited to frontal cortex and cerebellum)	+	human	proteomics	Krapfenbauer K, 2003
Prx-6	intracerebral prion injection in mouse	(preferentially in astrocytes)	+	mouse	Northern blot	Kopacek J, 2000
Prx-6	sCJD	frontal cortex (study limited to frontal cortices)	+	human	proteomics	Krapfenbauer K, 2002

Increased or -, decreased as determined in the study or as previously established.  
 Expression levels compared to controls: +, increased; -, decreased; =, no change.



in contrast to non-ischemic controls, ADF/TRX was expressed in glial cells in the CA1 and dentate hilus of the hippocampus (Tomimoto *et al.*, 1993). Weak staining was observed in the striatum and vascular endothelial cells, with no staining detected in astroglia and microglia in control gerbil and rat (Tomimoto *et al.*, 1993; Asahina *et al.*, 1998; Takagi *et al.*, 1998). Several studies reported a striking association between TrxI up-regulation in the CNS during neuron survival following various injuries that result in oxidative stress. Mechanical nerve injury and transient focal brain ischemia induce TrxI in various brain regions and cell types, with induction patterns suggesting TrxI function(s) in neuroprotection or regeneration of the brain following injury and oxidative stress (Stemme *et al.*, 1985; Tomimoto *et al.*, 1993; Lippoldt *et al.*, 1995; Asahina *et al.*, 1998; Mansur *et al.*, 1998; Takagi *et al.*, 1998). TrxI up-regulation is also observed in response to ischemic stress (Takagi *et al.*, 1998; Takagi *et al.*, 1998; Hattori *et al.*, 2002). Conversely, the vulnerability of cortical neurons isolated from stroke-prone spontaneously hypersensitive rats to transient hypoxia/reoxygenation was associated with inefficient up-regulation of TrxI and TrxII compared with normal Wistar rats (Yamagata *et al.*, 2000). Exposure of neonatal rats to hypoxia-ischemia resulted in reduction of Trx immunoreactivity and stimulation of peroxynitrite production associated with neuronal damage in the infarcted brain region, while surviving neurons of the peri-infarct cortex showed TrxI induction, again suggesting neuroprotective function(s) of Trx (Hattori *et al.*, 2002). Induction of TrxI was also considered to contribute to the mechanism of pre-conditioning neuroprotection. Preconditioning of SH-SY5Y neuronal cells by transient serum depletion produces the hormesis phenomenon, characterized by enhanced tolerance to subsequent lethal oxidative stress, associated with increased expression of several proteins, including antioxidant enzymes (TrxI, PrxI, MnSOD) and antiapoptotic Bcl-2 (Andoh *et al.*, 2002). The involvement of TrxI in preconditioning-induced neuroprotection was indicated by the demonstration that antisense-mediated inhibition of TrxI expression reduced the hormesis effect (Andoh *et al.*, 2002).

Little is known about the regulation of TrxII gene expression in the CNS. The induction patterns of TrxI and TrxII appear to be similar in cortical neurons exposed to hypoxia reoxygenation, suggesting that TrxII is an oxidative stress-regulated gene, which may share common regulatory elements with TrxI (Yamagata *et al.*, 2000). TrxII expression can be induced by dexamethasone in rat brain, but exclusively in paraventricular hypothalamic and reticular thalamic nuclei (Rybnikova *et al.*, 2000). The basis for this region-specific TrxII induction, which is unrelated to oxidative stress, remains to be determined.

## **2.7. Altered Expression of Trx and TrxR in Neurodegenerative Diseases**

Among the few studies available on the expression of Trx cycle enzymes in neurodegenerative processes (see Table 3), one report indicated increased TrxI protein and mRNA levels in the grey and white matters of AD brains, the increase being most

Table 3. Expression of Trxs and TrxRs in the CNS.

Trx/TrxR	Pathology, experimental system, stress, insult	Expression	Level	Species	Reference
Trx1	sciatic nerve crush	dilatated axons both proximally and distally to the crush	+	rat	Stemme S, 1985
Trx1	3-NP (systemic injection)	hippocampal (CA3), dentate gyrus, lateral striatum	+	rat	Suginio T, 1999
TrxR	cortical neuron cultures exposed to t-BHQ	cortical astrocytes	+	mouse	Eftekharpour E., 2000
TrxR	cortical neuron cultures exposed to t-BHQ	cortical neurons	=	mouse	Eftekharpour E., 2000
Trx-1	spinal cord fetal neuron cultures exposed to GGA	spinal cord fetal neurons culture	+	rat	Kikuchi S, 2002
Trx1	SH-SY5Y cells exposed to 17- $\beta$ -estradiol	b-estradiol - SH-SY5Y cell line	+	human	Lee J. M, 2003.
Trx1	middle cerebral artery occlusion	perifocal ischemic region	+	rat	Takagi Y, 1998
Trx1	middle cerebral artery occlusion	core region	-	rat	Takagi Y, 1998
Trx1	partial unilateral hemitranssection	cortical neuron	+	rat	Lippoldt A, 1995
Trx1, Trx2	hypoxia/reoxygenation of culture cortical neurons	cortical neuron	+	rat	Yamagata K, 2000
Trx2	dexamethasone (ip injection)	paraventricular hypothalamic and reticular thalamic nuclei	+	rat	Ryobnikova E 2000
Trx1	Alzheimer's disease	white matter astrocytes (preferentially)	+	human	Asahina M, 1998
Trx1	Alzheimer's disease	amygdala hippocampus/parahippocampal gyrus	-	human	Lovell MA, 2000
TrxR	Alzheimer's disease	amygdala/cerebellum	+	human	Lovell MA, 2000
Trx1	MPP+ exposure	PC12 cell line	-	rat	Bai, J 2002
Trx1	hypoxia-ischemia	injured region (cortex, striatum)	-	rat	Hattori I 2002
Trx1	hypoxia-ischemia	around injured region	+	rat	Hattori I 2002
Trx1	hypoxia-ischemia	cerebral hemisphere ipsilateral to the carotid ligation	+	rat	Hattori I 2002

Increased or -, decreased as determined in the study or as previously established. Expression levels compared to controls: +, increased; -, decreased; =, no change.

pronounced in white matter astrocytes (Asahina *et al.*, 1998). The significance of these observations, however, is questionable, since only three out of five AD samples analyzed showed increased TrxI expression compared with three healthy controls. In contrast, another study involving 10 AD and 10 control subjects reported low TrxI levels in the AD brain, which were observed in various regions including the amygdala and hippocampus/parahippocampal gyrus, where the difference from control subjects reached statistical significance (Lovell *et al.*, 2000). Interestingly, the same study also showed that treatments of primary rat hippocampal cell cultures with exogenous Trx or TrxR from *Escherichia coli* enhanced their survival against  $\beta$ -amyloid cytotoxicity, a pro-oxidant peptide thought to contribute to plaque formation in AD brain. Considered together, these results suggest that Trx plays a protective role in AD, and that TrxI deficit might eventually contribute to increased oxidative stress and subsequent neurodegeneration in AD (Lovell *et al.*, 2000). Assessment of TrxI expression in AD clearly warrants larger scale investigations. The significance of any aberrant expression pattern of Trx cycle enzymes reported in various neurodegenerative conditions, including AD, is not evident. Although most of the reported observations appear to reflect a protective role of the investigated enzyme, recent studies suggest that, in some cases at least, the Trx-related protein may also induce neurotoxicity (Requena and Levine, 2001). In fact, it is conceivable that deregulation of any of these enzymes could have either beneficial or detrimental effects on brain cell survival and function, depending on the brain region, cell type and pathology investigated. The expression of Trx cycle enzymes must be tightly regulated in order to maintain optimal brain cell function and to mount appropriate defenses in response to stress conditions.

In contrast to low TrxI protein level, TrxR activity is significantly elevated in the amygdala and cerebellum of AD brain (Lovell *et al.*, 2000). Concomitant with enhanced TrxR activity, activities of other main antioxidant enzymes such as GPx, GSSG reductase, catalase and SOD1 were also found elevated in several regions of AD brain, where lipid peroxidation was most pronounced (Lovell *et al.*, 1995). The elevation of antioxidant enzyme status was suggested to reflect a compensatory response to counteract increased oxidative stress characterizing this pathology (Lovell *et al.*, 1995; Lovell *et al.*, 2000). Further studies are needed to analyze the distinct expression of TrxRI and TrxRII isoforms in AD brain. (Eftekharpour *et al.*, 2000; Bai *et al.*, 2002; Kikuchi *et al.*, 2002; Lee *et al.*, 2003)

## 2.8. Neuroprotective Effects of Transgenic TrxI Expression

Transgenic mice that overexpress human TrxI (hTrxI) in various tissues including brain (fivefold increase) have been generated (Takagi *et al.*, 1999). In these mice, expression of hTrxI is localized in pyramidal neurons, hippocampus, cortex, vascular endothelial cells and glial cells. These transgenic mice display extended life span, an important observation linking increased longevity to the expression of an antioxidant enzyme in mammals (Mitsui *et al.*, 2002). In addition, these mice are more resistant to focal brain ischemia (Takagi *et al.*, 1999) or kainate-mediated excitotoxic stress in

the hippocampus (Takagi *et al.*, 2000) than their wild-type littermates. The increase in protein carbonyl content after 1-h focal ischemia, a marker of protein oxidation, was suppressed in the brain of TrxI transgenic mice, suggesting a neuroprotective antioxidant role for TrxI (Takagi *et al.*, 1999). In addition, *c-fos* induction by ischemia, an effect thought to attenuate ischemic injury, was enhanced in TrxI-transgenic mice compared with non-transgenic animals. Moreover, the neurological deficit caused by ischemic treatment improved in transgenic mice compared with their wild-type littermates. Considered together, these observations point to neuroprotective functions of TrxI in the CNS (Takagi *et al.*, 1999; Mitsui *et al.*, 2002). To what extent these Trx-mediated effects resulted from enhanced ROS detoxification by itself (Mitsui *et al.*, 1992), from enhancing the redox recycling of Prxs or from modulation of signaling functions through multiple TrxI interactions with various protein partners (Powis *et al.*, 2000; Nordberg and Arner, 2001) is not known at present.

## 2.9. PrxI-presenilin-1 Interactions

PrxI was recently shown to interact with presenilin-1 (PS-1) (Zhou *et al.*, 2002), a transmembrane protein involved in the cleavage of other intramembranous proteins, such as the  $\beta$ -amyloid precursor protein, Notch and Ire1p. PS-1 is mutated in about 50% of cases of familial AD (FAD). Overexpression of PrxI by plasmid microinjection induced apoptosis in primary cultures of superior cervical ganglion sympathetic (SCG) neurons, and to accelerate SCG neuronal death caused by NGF deprivation (Zhou *et al.*, 2002). Both effects were blocked by co-expression of wild-type PS-1 but not of the truncated PS-1 mutant that lacks exon 10, a region which interacts with PrxI and is mutated in some forms of FAD. However, it is not clear how excess PrxI causes apoptosis in SCG and how PS-1 protects against PrxI-mediated neuronal death (Zhou *et al.*, 2002).

## 2.10. Prx-mediated Neuroprotection

PrxII overexpression was reported to protect cultured neuronal cells from cell death induced by growth factor depletion (Ichimiya *et al.*, 1997). Prx could scavenge both  $H_2O_2$  and peroxynitrite ( $ONOO^-$ ) in co-operation with thiol (Bryk *et al.*, 2000). We demonstrated by Western blotting that the excitotoxicity evoked by ibotenic acid induced nitration of hippocampal proteins and that adenoviral gene transfer of PrxIII completely inhibited protein nitration and markedly reduced gliosis, a post-neuronal cell death event (Hattori *et al.*, 2003). Although it is possible that Prx III indirectly prevents  $ONOO^-$  production via  $H_2O_2$  scavenging action (Bryk *et al.*, 2000), we suggested that Prx-III functions in vivo as a protective  $ONOO^-$  scavenger (Hattori *et al.*, 2003). Systemic administration of recombinant PrxV also provided protection against ibotenate-induced excitotoxic stress in the mouse (Plaisant *et al.*, 2003). In contrast to PrxV-mediated protective effects against ibotenate excitotoxicity, PrxV provided no protection against excitotoxic stress induced by the AMPA receptor activator S-bromowillardiine (Plaisant *et al.*, 2003). The authors suggested that  $H_2O_2$

could be the dominant ROS produced by NMDA receptor activation, while AMPA-kainate receptor might generate non-peroxide ROS that would not be detoxified efficiently by Prx enzymes. This interpretation is supported by the observation that superoxide rather than peroxide production is associated with apoptotic cell death upon selective activation of AMPA receptors in hippocampal cultures (Rego *et al.*, 2003).

### 3. CONCLUDING REMARKS AND PERSPECTIVES

Positive immunoreactivities for PrxII-V, but not PrxI and VI, are normally detected in neurons. On the other hand, proteomic approaches indicate up-regulation of cytosolic PrxII and down-regulation of mitochondrial PrxIII in AD and PD. In contrast, PrxI and PrxVI are normally expressed in glial cells, and are induced under disease states.

These differences in the distribution and expression patterns may reflect difference in physiological and pathological roles. Changes in protein levels of secretable PrxIV or mitochondrial, peroxisomal and cytosolic PrxV levels in various CNS conditions remain to be determined in future studies. Many proteomic studies outlined the expression patterns and changes in Prxs and Trxs in the normal and diseased CNS. However, because significant neuronal cell death and glial cell growth in some neural diseases have been reported, it is necessary to define the types of cells that express certain amount of and redox state of Prxs. Thus, proteomic approaches as well as cellular protein distribution analysis will be necessary in any future analysis. Several studies have reported that Trx provides neuroprotective effects. Since it was demonstrated that Trx itself has some antioxidative activity, it is important to determine whether Trx is overexpressed or whether enhancement of Prx redox recycling provides crucial antioxidative effect(s) in the presence of Trx overexpression. PrxI-, II- and VI-deficient mice are currently available, but none of the studies reported an abnormal CNS phenotype. We are interested in whether or not some CNS deficits will be caused by PrxIII-, IV- or V-deficient mice. The glutathione (GSH) system, another redox cycling antioxidative system, plays important roles in neuronal cell survival under oxidative insults. At present, we cannot demonstrate the different meanings of the Prx and GSH systems. A detailed stoichiometric study of Prx-5 recently revealed an extremely rapid reduction of ONOO<sup>-</sup> with a high constant rate of  $7 \times 10^7 \text{ M}^{-1}\text{s}^{-1}$ , which was five times higher than that of Gpx-1 (Dubuisson *et al.*, 2004). This is probably, as far as we know, the first approach to show distinct antioxidative function of Prx. It is hoped that the above issues will be addressed in the near future through analysis of Prxs functional properties in the CNS.

### REFERENCES

- Alexandrova, M., Bochev, P., Markova, V., Bechev, B., Popova, M., Danovska, M., Simeonova, V., 2004, Dynamics of free radical processes in acute ischemic stroke: influence on neurological status and outcome. *J. Clin. Neurosci.* **11**: 501–506.

- Andoh, T., Chock, P.B., Chiueh, C.C., 2002, The roles of thioredoxin in protection against oxidative stress-induced apoptosis in SH-SY5Y cells. *J. Biol. Chem.* **277**: 9655–9660.
- Asahina, M., Yamada, T., Yoshiyama, Y., Yodoi, J., 1998, Expression of adult T cell leukemia-derived factor in human brain and peripheral nerve tissues. *Dement. Geriatr. Cogn. Disord.* **9**: 181–185.
- Bai, J., Nakamura, H., Hattori, I., Tanito, M., Yodoi, J., 2002, Thioredoxin suppresses 1-methyl-4-phenylpyridinium-induced neurotoxicity in rat PC12 cells. *Neurosci. Lett.* **321**: 81–84.
- Beal, M. F., 1995, Aging, energy, and oxidative stress in neurodegenerative diseases. *Ann. Neurol.* **38**: 357–366.
- Beal, M.F., Ferrante, R.J., Browne, S.E., Matthews, R.T., Kowall, N.W., Brown, R.H., Jr., 1997, Increased 3-nitrotyrosine in both sporadic and familial amyotrophic lateral sclerosis. *Ann. Neurol.* **42**: 644–654.
- Bellomo, G., Mirabelli, F., Vairetti, M., Iosi, F., Malorni, W., 1990, Cytoskeleton as a target in menadione-induced oxidative stress in cultured mammalian cells. I. Biochemical and immunocytochemical features. *J. Cell. Physiol.* **143**: 118–128.
- Bryk, R., Griffin, P., Nathan, C., 2000, Peroxynitrite reductase activity of bacterial peroxiredoxins. *Nature* **407**: 211–215.
- Chen, W., Ji, J., Ru, B., 2005, Proteomic analysis of corticobasal degeneration: a case study of corticobasal degeneration at the proteome level. *J. Neuropsychiatry Clin. Neurosci.* **17**: 364–371.
- Chen, W., Ji, J., Xu, X., He, S., Ru, B., 2003, Proteomic comparison between human young and old brains by two-dimensional gel electrophoresis and identification of proteins. *Int. J. Dev. Neurosci.* **21**: 209–216.
- Demirkaya, S., Topcuoglu, M.A., Aydin, A., Ulas, U.H., Isimer, A.I., 2001, Malondialdehyde, glutathione peroxidase and superoxide dismutase in peripheral blood erythrocytes of patients with acute cerebral ischemia. *Eur. J. Neurol.* **8**: 43–51.
- Dexter, D.T., Holley, A.E., Flitter, W.D., Slater, T.F., Wells, F.R., Daniel, S.E., Lees, A.J., Jenner, P., Marsden, C.D., 1994, Increased levels of lipid hydroperoxides in the parkinsonian substantia nigra: an HPLC and ESR study. *Mov. Disord.* **9**: 92–97.
- Dyrks, T., Dyrks, E., Masters, C.L., Beyreuther, K., 1993, Amyloidogenicity of rodent and human beta A4 sequences. *FEBS Lett.* **324**: 231–236.
- Eftekharpour, E., Holmgren, A., Juurlink, B H., 2000, Thioredoxin reductase and glutathione synthesis is upregulated by t-butylhydroquinone in cortical astrocytes but not in cortical neurons. *Glia* **31**: 241–248.
- Ferrante, R. J., Browne, S.E., Shinobu, L.A., Bowling, A.C., Baik, M.J., MacGarvey, U., Kowall, N.W., Brown, R.H., Jr., Beal, M.F., 1997, Evidence of increased oxidative damage in both sporadic and familial amyotrophic lateral sclerosis. *J. Neurochem.* **69**: 2064–2074.
- Floyd, R.A., Hensley, K., 2002, Oxidative stress in brain aging. Implications for therapeutics of neurodegenerative diseases. *Neurobiol. Aging* **23**: 795–807.
- Hattori, F., Murayama, N., Noshita, T., Oikawa, S., 2003, Mitochondrial peroxiredoxin-3 protects hippocampal neurons from excitotoxic injury in vivo. *J. Neurochem.* **86**: 860–868.
- Hattori, I., Takagi, Y., Nozaki, K., Kondo, N., Bai, J., Nakamura, H., Hashimoto, N., Yodoi, J., 2002, Hypoxia-ischemia induces thioredoxin expression and nitrotyrosine formation in new-born rat brain. *Redox Rep.* **7**: 256–259.
- Ichimiya, S., Davis, J.G., O'Rourke, D.M., Katsumata, M., Greene, M.I., 1997, Murine thioredoxin peroxidase delays neuronal apoptosis and is expressed in areas of the brain most susceptible to hypoxic and ischemic injury. *DNA Cell Biol.* **16**: 311–321.
- Jin, M.H., Lee, Y.H., Kim, J.M., Sun, H.N., Moon, E.Y., Shong, M.H., Kim, S.U., Lee, S.H., Lee, T.H., Yu, D.Y., Lee, D.S., 2005, Characterization of neural cell types expressing peroxiredoxins in mouse brain. *Neurosci. Lett.* **381**: 252–257.
- Kikuchi, S., Shinpo, K., Takeuchi, M., Tsuji, S., Yabe, I., Niino, M., Tashiro, K., 2002, Effect of geranylgeranylacetone on cellular damage induced by proteasome inhibition in cultured spinal neurons. *J. Neurosci. Res.* **69**: 373–381.
- Kim, S. H., Fountoulakis, M., Cairns, N., Lubec, G., 2001, Protein levels of human peroxiredoxin subtypes in brains of patients with Alzheimer's disease and Down syndrome. *J. Neural. Transm. Suppl* (61): 223–235.

- Kopacek, J., Sakaguchi, S., Shigematsu, K., Nishida, N., Atarashi, R., Nakaoke, R., Moriuchi, R., Niwa, M., Katamine, S., 2000, Upregulation of the genes encoding lysosomal hydrolases, a perforin-like protein, and peroxidases in the brains of mice affected with an experimental prion disease. *J. Virol.* **74**: 411–417.
- Krapfenbauer, K., Engidawork, E., Cairns, N., Fountoulakis, M., Lubec, G., 2003, Aberrant expression of peroxiredoxin subtypes in neurodegenerative disorders. *Brain Res.* **967**: 152–160.
- Krapfenbauer, K., Yoo, B.C., 2002, Expression patterns of antioxidant proteins in brains of patients with sporadic Creutzfeldt-Jacob disease. *Electrophoresis* **23**: 2541–2547.
- Lee, J. M., Shih, A.Y., Murphy, T.H., Johnson, J.A., 2003, NF-E2-related factor-2 mediates neuroprotection against mitochondrial complex I inhibitors and increased concentrations of intracellular calcium in primary cortical neurons. *J. Biol. Chem.* **278**: 37948–37956.
- Lippoldt, A., Padilla, C.A., Gerst, H., Andbjør, B., Richter, E., Holmgren, A., Fuxe, K., 1995, Localization of thioredoxin in the rat brain and functional implications. *J. Neurosci.* **15**: 6747–6756.
- Liu, H., Uno, M., Kitazato, K.T., Suzue, A., Manabe, S., Yamasaki, H., Shono, M., Nagahiro, S., *et al.*, 2004, Peripheral oxidative biomarkers constitute a valuable indicator of the severity of oxidative brain damage in acute cerebral infarction. *Brain Res.* **1025**: 43–50.
- Lovell, M. A., Ehmann, W.D., Butler, S.M., Markesbery, W.R., 1995, Elevated thiobarbituric acid-reactive substances and antioxidant enzyme activity in the brain in Alzheimer's disease. *Neurology* **45**: 1594–1601.
- Lovell, M.A., Xie, C., Gabbita, S.P., Markesbery, W.R., 2000, Decreased thioredoxin and increased thioredoxin reductase levels in Alzheimer's disease brain. *Free Radic. Biol. Med.* **28**: 418–427.
- Mansur, K., Iwahashi, Y., Kiryu-Seo, S.Su., Q.Namikawa, K., Yodoi, J., Kiyama, H., 1998, Up-regulation of thioredoxin expression in motor neurons after nerve injury. *Brain Res. Mol. Brain Res.* **62**: 86–91.
- McIntosh, L.J., Trush, M.A., Troncoso, J. C., 1997, Increased susceptibility of Alzheimer's disease temporal cortex to oxygen free radical-mediated processes. *Free Radic. Biol. Med.* **23**: 183–190.
- Mecocci, P., MacGarvey, U., Beal, M.F., 1994, Oxidative damage to mitochondrial DNA is increased in Alzheimer's disease. *Ann. Neurol.* **36**: 747–751.
- Mitsui, A., Hamuro, J., Nakamura, H., Kondo, N., Hirabayashi, Y., Ishizaki-Koizumi, S., Hirakawa, T., Inoue, T., Yodoi, J., 2002, Overexpression of human thioredoxin in transgenic mice controls oxidative stress and life span. *Antioxid. Redox Signal.* **4**: 693–696.
- Mitsui, A., Hirakawa, T., Yodoi, J., 1992, Reactive oxygen-reducing and protein-refolding activities of adult T cell leukemia-derived factor/human thioredoxin. *Biochem. Biophys. Res. Commun.* **186**: 1220–1226.
- Morimoto, T., Globus, M.Y., Busto, R., Martinez, E., Ginsberg, M. D., 1996, Simultaneous measurement of salicylate hydroxylation and glutamate release in the penumbral cortex following transient middle cerebral artery occlusion in rats. *J. Cereb. Blood Flow Metab.* **16**: 92–99.
- Nagayama, T., Lan, J., Henshall, D.C., Chen, D., O'Horo, C., Simon, R. P., Chen, J., 2000, Induction of oxidative DNA damage in the peri-infarct region after permanent focal cerebral ischemia. *J. Neurochem.* **75**: 1716–1728.
- Nakaso, K., Kitayama, M., Ishii, T., Bannai, S., Yanagawa, T., Kimura, K., Nakashima, K., Ohama, E., Yamada, K., 1999, Effects of kainate-mediated excitotoxicity on the expression of rat counterparts of A170 and MSP23 stress proteins in the brain. *Brain Res. Mol. Brain Res.* **69**: 155–163.
- Nakaso, K., Kitayama, M., Mizuta, E., Fukuda, H., Ishii, T., Nakashima, K., Yamada, K., 2000, Co-induction of heme oxygenase-1 and peroxiredoxin I in astrocytes and microglia around hemorrhagic region in the rat brain. *Neurosci. Lett.* **293**: 49–52.
- Nakaso, K., Yano, H., Fukuhara, Y., Takeshima, T., Wada-Isoe K., Nakashima K., 2003, PI3K is a key molecule in the Nrf2-mediated regulation of antioxidative proteins by hemin in human neuroblastoma cells. *FEBS Lett.* **546**: 181–184.
- Nordberg, J., Arner, E.S., 2001, Reactive oxygen species, antioxidants, and the mammalian thioredoxin system. *Free Radic. Biol. Med.* **31**(): 1287–1312.
- Patenaude, A., Murthy, M.R., Mirault, M.E., 2005, Emerging roles of thioredoxin cycle enzymes in the central nervous system. *Cell Mol. Life Sci.* **62**: 1063–1080.

- Piantadosi, C. A., Zhang J., 1996, Mitochondrial generation of reactive oxygen species after brain ischemia in the rat. *Stroke* **27**: 327–331; discussion 332.
- Plaisant, F., Clippe, A., Van der Stricht, D., Knoops, B., Gressens, P., 2003, Recombinant peroxiredoxin 5 protects against excitotoxic brain lesions in newborn mice. *Free Radic. Biol. Med.* **3**: 862–872.
- Powis, G., Montfort W.R., 2001, Properties and biological activities of thioredoxins. *Ann. Rev. Pharmacol. Toxicol.* **41**: 261–295.
- Powis, G., Mustacich, D., Coon, A., 2000, The role of the redox protein thioredoxin in cell growth and cancer. *Free Radic. Biol. Med.* **29**: 312–322.
- Rego, A.C., Monteiro, N.M., Silva, A.P., Gil, J., Malva, J.O., Oliveira, C.R., 2003, Mitochondrial apoptotic cell death and moderate superoxide generation upon selective activation of non-desensitizing AMPA receptors in hippocampal cultures. *J. Neurochem.* **86**: 792–804.
- Requena, J.R., Levine, R.L., 2001, Thioredoxin converts the Syrian hamster (29–231) recombinant prion protein to an insoluble form. *Free Radic. Biol. Med.* **30**: 141–147.
- Rosen, D. R., Siddique, T., Patterson, D., Figlewicz, D.A., Hentati, A., Donaldson, D., Goto, J., O'Regan, J.P., Deng, H.X., 1993, Mutations in Cu/Zn superoxide dismutase gene are associated with familial amyotrophic lateral sclerosis. *Nature* **362**: 59–62.
- Rozell, B., Hansson, H.A., Luthman, M., Holmgren, A., (1985, Immunohistochemical localization of thioredoxin and thioredoxin reductase in adult rats. *Eur. J. Cell Biol.* **38**: 79–86.
- Rybnikova, E., Dandimopoulos, A.E., Gustafsson, J.A., Spyrou, G., Pelto-Huikko, M., 2000, Expression of novel antioxidant thioredoxin-2 in the rat brain. *Eur. J. Neurosci.* **12**: 1669–1678.
- Sakamoto, A., Ohnishi, S.T., Ohnishi, T., Ogawa, R., 1991, Relationship between free radical production and lipid peroxidation during ischemia-reperfusion injury in the rat brain. *Brain Res.* **554**: 186–192.
- Sarafian, T.A., Verity, M.A., Vinters, H.V., Shih, C.C., Shi, L., Ji, X.D., Dong, L., Shau, H., 1999, Differential expression of peroxiredoxin subtypes in human brain cell types. *J. Neurosci. Res.* **56**: 206–212.
- Seo, M.S., Kang, S.W., Kim, K., Baines, I.C., Lee, T.H., Rhee, S.G., 2000, Identification of a new type of mammalian peroxiredoxin that forms an intramolecular disulfide as a reaction intermediate. *J. Biol. Chem.* **275**: 20346–20354.
- Stemme, S., Hansson, H.A., Holmgren, A., Rozell, B., 1985, Axoplasmic transport of thioredoxin and thioredoxin reductase in rat sciatic nerve. *Brain Res.* **359**: 140–146.
- Su, J.H., Deng, G., Cotman, C.W., 1997, Neuronal DNA damage precedes tangle formation and is associated with up-regulation of nitrotyrosine in Alzheimer's disease brain. *Brain Res.* **774**: 193–199.
- Takagi, Y., Hattori, I., Nozaki, K., Mitsui, A., Ishikawa, M., Hashimoto, N., Yodoi, J., 2000, Excitotoxic hippocampal injury is attenuated in thioredoxin transgenic mice. *J. Cereb. Blood Flow Metab.* **20**: 829–833.
- Takagi, Y., Horikawa, F., Nozaki, K., Sugino, T., Hashimoto, N., Yodoi, J., 1998, Expression and distribution of redox regulatory protein, thioredoxin during transient focal brain ischemia in the rat. *Neurosci. Lett.* **251**: 25–28.
- Takagi, Y., Mitsui, A., Nishiyama, A., Nozaki, K., Sono, H., Gon, Y., Hashimoto, N., Yodoi, J., 1999, Overexpression of thioredoxin in transgenic mice attenuates focal ischemic brain damage. *Proc. Natl. Acad. Sci. USA* **96**: 4131–4136.
- Takagi, Y., Tokime, T., Nozaki, K., Gon, Y., Kikuchi, H., Yodoi, J., 1998, Redox control of neuronal damage during brain ischemia after middle cerebral artery occlusion in the rat: immunohistochemical and hybridization studies of thioredoxin. *J. Cereb. Blood Flow Metab.* **18**: 206–214.
- Tomimoto, H., Akiguchi, I., Wakita, H., Kimura, J., Hori, K., Yodoi, J., 1993, Astroglial expression of ATL-derived factor, a human thioredoxin homologue, in the gerbil brain after transient global ischemia. *Brain Res.* **625**: 1–8.
- Troncoso, J.C., Costello, A., Watson, A.L., Jr., Johnson, G.V., 1993, In vitro polymerization of oxidized tau into filaments. *Brain Res.* **613**: 313–316.
- Watabe, S., Hiroi, T., Yamamoto, Y., Fujioka, Y., Hasegawa, H., Yago, N., Takahashi, S.Y., 1997, SP-22 is a thioredoxin-dependent peroxide reductase in mitochondria. *Eur. J. Biochem.* **249**: 52–60.



- White, B.C., Daya, A., DeGracia, D.J., O'Neil, B.J., Skjaerlund, J.M., Trumble, S., Krause, G.S., Rafols, J.A., 1993, Fluorescent histochemical localization of lipid peroxidation during brain reperfusion following cardiac arrest. *Acta Neuropathol.(Berl.)* **86**: 1–9.
- Wood, Z.A., Schroder, E., Harris, J.R., Poole, L.B., 2003, Structure, mechanism and regulation of peroxiredoxins. *Trends Biochem. Sci.* **28**: 32–40.
- Yamagata, K., Tagami, M., Ikeda, K., Yamori, Y., Nara, Y., 2000, Altered gene expressions during hypoxia and reoxygenation in cortical neurons isolated from stroke-prone spontaneously hypertensive rats. *Neurosci. Lett.* **284**: 131–134.
- Yang, K.S., Kang, S.W., Woo, H.A., Hwang, S.C., Chae, H.Z., Kim, K., Rhee, S.G., 2002, Inactivation of human peroxiredoxin I during catalysis as the result of the oxidation of the catalytic site cysteine to cysteine-sulfinic acid. *J. Biol. Chem.* **277**: 38029–38036.
- Yoritaka, A., Hattori, N., Uchida, K., Tanaka, M., Stadtman, E.R., Mizuno, Y., 1996, Immunohistochemical detection of 4-hydroxynonenal protein adducts in Parkinson disease. *Proc. Natl. Acad. Sci. USA* **93**: 2696–2701.
- Zhou, Y., Zhang, W., Easton, R., Ray, J.W., Lampe, P., Jiang, Z., Brunkan, A.L., Goate, A., Johnson, E M., Wu, J.Y., 2002, Presenilin-1 protects against neuronal apoptosis caused by its interacting protein PAG. *Neurobiol. Dis.* **9**: 126–38.

## CHAPTER 18

# STRESS-INDUCED PEROXIREDOXINS

TETSURO ISHII AND TORU YANAGAWA

*Majors of Medical Sciences, Graduate School of Comprehensive Human Sciences, University of Tsukuba, Tsukuba, Ibaraki, 305-8575 Japan*

**Abstract:** Some members of the Prx family are up-regulated in cells under stress conditions. Prx I is the major cytoplasmic Prx and is known as a stress-inducible antioxidant enzyme. Various stress agents or conditions activate Prx I gene expression *in vitro* and *in vivo*. The transcription factor Nrf2 and its inhibitor Keap1 play an essential role in the regulation of the stress-induced Prx I gene activation through the ARE/EpRE (antioxidant/electrophile response element). The expression levels of Prx II and III are also up-regulated under stress conditions, although the molecular mechanisms of their up-regulation have not yet been thoroughly studied. Gene expression of both Prx I and II is activated by X-ray irradiation of the testis. Mitochondrial Prx III is up-regulated by stress agents in both cultured cells and experimental animals. The up-regulation of the Prxs in cells and tissues under oxidative stress conditions is one of the cellular recovery responses after oxidative damage

**Keywords:** Oxidative stress, Prx I, Prx II, Prx III, Electrophile, Nrf2, Macrophage, Arsenic, Radiation, Hyperoxia

### 1. INTRODUCTION

Since the discovery of a new class of antioxidant proteins, the peroxiredoxins (Prx), many studies to elucidate their structure, enzymatic activity, and molecular functions have been performed, as described in other chapters. The Prxs are expressed at high levels in cells and play an important role in cell peroxide detoxification. Some of the Prxs are up-regulated under stress conditions, thereby enhancing the cellular defense capacity against oxidative damage or facilitating the recovery process from such damage.

Prx I, the major cytosolic Prx, can be up-regulated by oxidative stress-inducing agents or mitogenic stimuli through different mechanisms. We previously cloned murine Prx I, first termed MSP23 (macrophage stress protein 23 kDa), from peritoneal macrophages as a major diethylmaleate (DEM)-inducible protein (Ishii *et al.*, 1993). DEM is an electrophile known as a sulfhydryl-reactive agent

or GSH-depleting agent. Since Prxs reduce  $H_2O_2$  without using GSH, their action could compensate for the loss of glutathione peroxidase function, especially under conditions of low cellular GSH. We showed that the stress-induced gene expression of Prx I is controlled by NF-E2-related transcription factor 2 (Nrf2) (Ishii *et al.*, 2000a). Since Nrf2 is essential for regulating the ARE/EpRE-mediated expression of detoxifying enzymes such as NAD(P)H:quinone oxidoreductase (NQO1) and glutathione *S*-transferases (GSTs) (Itoh *et al.*, 1997), these results indicated that Prx I is one of the major players in the defense system against electrophilic agents.

Prx I has also been implicated in the cell cycle/growth and apoptosis signaling pathways. Human Prx I was first identified as PAG (proliferation associated gene) in Ras-transformed cancer cells (Prosperi *et al.*, 1993). PAG was later found to be a tyrosine kinase c-Abl-interacting protein. It binds to the SH3 domain of c-Abl and inhibits c-Abl's kinase activity and cyostatic function in fibroblasts (Wen and Van Etten, 1997), but the physiological significance of this interaction is not well understood. In addition, Prx I is up-regulated by mitogenic stimulation or during the S phase of the cell cycle and can be phosphorylated by cyclin-dependent kinases during mitosis. Phosphorylation of Prx I leads to its inactivation and accumulation of  $H_2O_2$  in the cell, which might be important for the progression of the cell cycle (Chang *et al.*, 2002).

This chapter will address recent research on the stress induction of mammalian Prx I, Prx II and III *in vitro* and *in vivo*. Although studies of Prx gene expression *in vivo* are currently limited, it is an appealing topic for future research with interesting medical implications.

## 2. ACTIVATION OF Prx I GENE EXPRESSION

### 2.1. Prx I gene Activation by Stress Agents in Macrophages

Prx I is the major Prx isoform expressed in the cytoplasm of a number of cell types. We studied the effects of various stress agents on the activation of the Prx I gene in murine peritoneal macrophages (Ishii *et al.*, 1993; Ishii *et al.*, 2000a). The Prx I expression level was low in fresh macrophages, but it gradually increased during culture in standard medium containing 10% fetal bovine serum. Supplementing the medium with 100  $\mu$ M DEM significantly enhanced the rate of increase of Prx I in the cells. However, also without DEM treatment the expression level of intracellular Prx I also increased with time, reaching a level similar to that of the DEM-treated cells in 24 h (Ishii *et al.*, 1993). To study the effects of stress agents on the expression of Prx I mRNA and protein, respectively, cells were incubated with the agents and assayed 5 and 8 h later. We subsequently showed that the electrophile-induced Prx I gene expression is mainly regulated by Nrf2 (Ishii *et al.*, 2000a) (Fig. 1). No accelerated increase by DEM of either the Prx I protein or

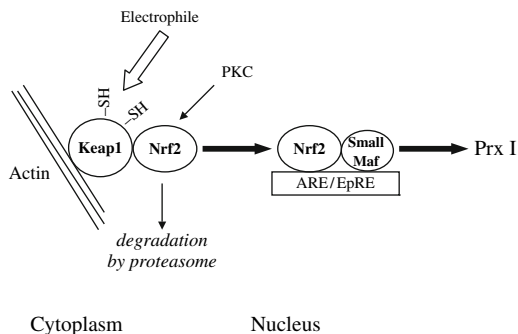
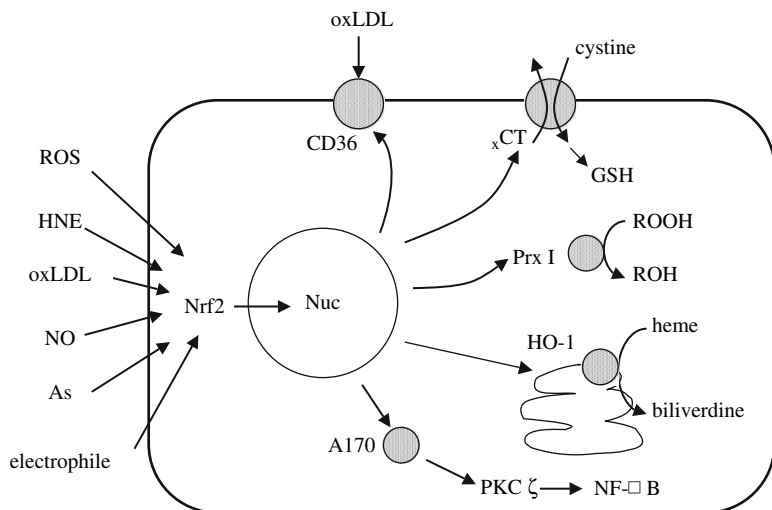

*Figure 1.* Transcription factor Nrf2 regulates Prx I gene expression through ARE/EpRE elements. Under normal conditions, Keap1 interacts with Nrf2 and facilitates the degradation of Nrf2 by proteasomes. Electrophilic agents bind to reactive sulfhydryl residues of Keap1, resulting in the release of Nrf2 from Keap1 and the accumulation of Nrf2 in the nucleus, where it induces Prx I gene expression. The phosphorylation of Nrf2 by PKC and inhibition of proteasome activity also result in the stabilization and nuclear accumulation of Nrf2

mRNA level was observed in *nrf2*-null mutant macrophages. In addition to DEM, CDNB (1-chloro-2,4-dinitrobenzene), catechol, *tert*-butylhydroquinone, menadione, paraquat, and glucose oxidase significantly increased the expression level of Prx I in an Nrf2-dependent manner. We later showed that oxidatively modified LDL and 4-hydroxynonenal, which could be produced *in vivo* under oxidative stress, also activated Nrf2 and increased the expression level of Prx I in macrophages (Ishii *et al.*, 2004).

## 2.2. Role of the Nrf2 and Keap1 System in the Induction of Prx I Expression by Electrophiles

Electrophiles and reactive oxygen species have been implicated in the pathogenesis of many diseases. The transcription factor Nrf2 was identified as a general regulator of one defense mechanism against such havoc. Nrf2 regulates the inducible expression of a group of detoxication enzymes, such as GST, NQO1 (Itoh *et al.*, 1997) and gastro-intestinal glutathione peroxidase (Banning *et al.*, 2006), via antioxidant response elements. Using peritoneal macrophages from Nrf2-deficient mice, we showed that Nrf2 also controls the expression of a group of electrophile- and oxidative stress-inducible proteins and activities, which includes Prx I, heme oxygenase-1 (HO-1), A170, and cystine membrane transport activity (Ishii *et al.*, 2000a) (Fig. 2). The response to electrophiles and reactive oxygen species-producing agents was profoundly impaired in Nrf2-deficient cells. Thus, Prx I was the first Prx whose expression in response to electrophiles and reactive oxygen species was shown to be regulated by Nrf2.



**Figure 2.** Prx I cooperates with other antioxidant gene products, the expressions of which are also up-regulated under oxidative stress by Nrf2. Nrf2 can be activated by reactive oxygen species (ROS), 4-hydroxynonenal (HNE), oxidatively modified LDL (oxLDL), nitric oxide (NO), arsenic (As), and various other types of electrophilic agents. In addition to Prx I, other gene products such as heme oxygenase-1 (HO-1), cystine membrane transporter (xCT), scavenger receptor CD36, and PKC $\zeta$ /ubiquitin interacting protein A170 are also induced by stress in a manner mediated by Nrf2 in murine peritoneal macrophages

### 2.3. Effects of Heme on the Expression and Activity of Prx I

Heme is a potential pro-oxidant, and it catalyzes the production of ROS in cells. HO-1 is the rate-limiting enzyme in heme degradation, and its substrate heme causes the activation of HO-1 gene expression. HO-1 gene activation by heme is controlled by both positive and negative transcription factors: it is activated by the enhancer Nrf2 and inactivated by the suppressor Bach 1, and these molecules compete to bind ARE elements (Sun *et al.*, 2004). Supplementing the culture medium with heme also causes the activation of Prx I gene expression in primary rat hepatocytes (Immenschuh *et al.*, 1995 and 2002). Prx I has a high affinity for heme ( $K_D = 55$  nM). This property was discovered during the isolation of heme-binding proteins from rat liver cytosol using a heme-affinity column (Iwahara *et al.*, 1995). Notably, micromolar levels of heme inhibit the antioxidant activity of Prx I (Ishii *et al.*, 1995), probably due to an interaction between heme and the catalytic sulfhydryl groups of Prx I. Therefore, the up-regulation of HO-1, which enhances the degradation of heme, should result in the protection of Prx I antioxidant activity.

We also found that both Prx I and HO-1 are induced in rat brain by intracerebral hemorrhage, which causes heme-related stress (Nakaso *et al.*, 2000). To investigate this process, blood was injected into the deep cerebrum, and the nearby thalamus and brain tissue was prepared 1, 14, and 28 d after the injection. The oligodendrocytes

constitutively express Prx I, but the hemorrhage did not cause any up-regulation of Prx I in these cells. However, in the reactive astrocytes and microglia surrounding a hemorrhagic region, which are presumed to play significant roles in the recovery of neurons, the expression of both HO-1 and Prx I was induced. The expression levels of both proteins, estimated from immunostaining, peaked at 1 and 14 d in the microglia and astrocytes, respectively. These results suggest that Prx I and HO-1 act cooperatively in the protection and recovery process in tissues surrounding an ischemic region (Nakaso *et al.*, 2000).

#### **2.4. Regulation of the Prx I Expression Levels by Serum or TPA**

Many cultured mammalian cells express a high basal level of Prx I. This makes it hard to observe any further up-regulation of Prx I expression levels by stress agents. In cultured aortic smooth muscle cells, for example, the Nrf2 activator DEM only slightly increased Prx I levels compared with the marked increase seen in freshly prepared macrophages (Ishii *et al.*, 2004). This is why the stress-induction of Prx I is not widely studied using cultured cells maintained *in vitro*. The high basal expression level of Prx I is partly due to its up-regulation by fetal calf serum (FCS), which is usually present at 10% (v/v) in standard culture medium. The up-regulation of Prx I by FCS does not depend on Nrf2, since cultured Nrf2-deficient cells express Prx I at a level similar to, or only slightly lower than, that in wild-type cells. Therefore, one approach is to incubate cells in medium low in FCS to down-regulate the Prx I level before analyzing the effects of stress agents.

Phorbol ester 12-O-tetradecanoylphorbol-13-acetate (TPA) activates Prx I gene expression in cultured rat hepatocytes and RAW264.7 monocytic cells. A signaling pathway involving protein kinase C, Ras, MEKK1, and p38 MAPK plays a major role in the transcriptional up-regulation of Prx I gene expression by TPA (Hess *et al.*, 2003). The effect of TPA appears to be partly mediated through Nrf2, since the phosphorylation of Nrf2 at Ser-40 by TPA-activated PKC causes its nuclear translocation and an ARE-mediated cellular antioxidant response (Huang *et al.*, 2000 and 2002).

#### **2.5. Signaling Pathways Leading to Prx I Gene Expression by Arsenic**

Arsenic activates or inhibits a variety of cellular signaling pathways that lead to cell growth, differentiation, and apoptosis. Arsenic is known to activate the expression of a group of heat shock proteins and HO-1. It also activates Prx I gene expression in cultured cells. Although Prx I induction by arsenate largely depends on Nrf2 in murine peritoneal macrophages (Ishii *et al.*, 2000a), also other signaling pathways are involved in other cell types. In cultured murine osteoblasts, the pathways leading to arsenate's activation of the Prx I gene appears to be complex (Li *et al.*, 2002). PKC $\delta$  was suggested to play an important role in the arsenate-induced accumulation of Nrf2 and up-regulation of Prx I (Li *et al.*, 2004). Related studies used cells that were preconditioned by low FCS so that the up-regulation of Prx I could easily be

observed. Although in osteoblasts Prx I induction by arsenate partly depends on Nrf2, mitogenic stimulation and other signaling pathways are also involved. Further analyses are needed to fully uncover the signaling pathways that contribute to the regulation of Prx I by arsenicals.

## 2.6. Effects of Oxidative Stress on the Expression of Prx I in the Lung

Respiratory organs are exposed to normoxic oxygen and have many opportunities to encounter toxic compounds that cause oxidative stress. The bronchial epithelium expresses Prxs I, III, V, and VI, and alveolar macrophages express Prxs I and III (Kinnula *et al.*, 2002). As described in Chapter 16, Prx VI is stress-inducible and plays an important role in protection of the lung (Kim *et al.*, 2003).

The exposure of experimental animals to hyperoxia causes oxidative stress in the lung that results in up-regulation of Prx I. When 4-day-old rats were exposed to > 95% O<sub>2</sub>, both the Prx I protein and mRNA levels in the lung started to increase after 24 h and reached 3- to 4-fold their normal levels at 72 h (Kim *et al.*, 2001). The Prx II levels, however, did not change upon exposure. Up-regulation of Prx I upon hyperoxia is also observed in baboon lung (Das *et al.*, 2001). In baboons, Prx I mRNA increased 3-fold 2 d after birth, and returned to normal level in 3 d. Premature baboons (140 d gestation) breathing 100% O<sub>2</sub> developed chronic lung disease within 7 to 14 d. Under these conditions the Prx I mRNA increased 3- to 4-fold (at day 6 and 10, respectively). When the premature baboons were exposed to 30 to 40% O<sub>2</sub> (as-needed oxygen), the Prx I mRNA had increased roughly 2-fold only at day 6 and 10. The up-regulation of Prx I mRNA by exposure to 95% O<sub>2</sub> was also demonstrated in lung explants from 140 d gestation fetal animals and in a human lung epithelial-like cell line, A549. The activation of the Prx I gene expression in A549 cells by exposure to 95% O<sub>2</sub> was significantly inhibited by PKC-specific inhibitors (Das *et al.*, 2001). Notably, Nrf2 is known to be an important gene in the protection of the lung from hyperoxia-induced damage (Cho *et al.*, 2002a,b). Nrf2<sup>-/-</sup> mice exposed to > 95% O<sub>2</sub> for 72 h showed higher levels of pulmonary hyperpermeability, macrophage infiltration and epithelial injury than did wild-type mice under the same conditions. This difference was probably due to the lower transcriptional activation of lung antioxidant defense enzymes in the mutant. These results indicate that in hyperoxic lung activation of Prx I gene expression is controlled by Nrf2 and contributes to the defense against pulmonary injury.

Prx I is also up-regulated in alveolar macrophages during the acute lung inflammation caused by carrageenan administration (Itoh *et al.*, 2004). In this inflammation model system, COX-2 plays an important role in the up-regulation of Prx I in the late phase of inflammation. COX-2 accounts for intracellular accumulation of 15d-PGJ<sub>2</sub>, which has been shown to activate Nrf2. The findings suggest that the anti-inflammatory activity of 15d-PGJ<sub>2</sub> is partly mediated through up-regulation of Prx I, which inhibits macrophage migration inhibitory factor, a crucial player in inflammation and sepsis (Itoh *et al.*, 2004).

## 2.7. Activation of Prx I gene Expression in Vivo by Dietary BHA

The dietary administration of 2(3)-*t*-butyl-4-hydroxyanisole (BHA), a synthetic phenolic antioxidant that is widely used as a food preservative, activates Prx I gene expression in mouse tissues (Ishii *et al.*, 2000b). Dietary BHA protects animals against various carcinogens, presumably through the induction of phase II detoxifying enzymes that defuse the activated electrophilic metabolites of carcinogens (Prestera *et al.*, 1993; Primiano *et al.*, 1997). The transcription factor Nrf2 plays an essential role in the activation of genes by dietary BHA in mediated by Nrf2 (Itoh *et al.*, 1997). Accordingly, the high levels of Prx I is expressed in mouse liver and proximal small intestine are further increased by dietary BHA like those of GSTs (Ishii *et al.*, 2002). Immunostaining of the small intestine revealed that Prx I is mainly expressed in the columnar epithelial cells, which are preferentially exposed to food derived chemical agents. Estimated by immunoblotting, Prx I levels in the proximal intestine and liver increased approximately 1.9- and 1.3-fold, respectively, in mice fed a diet containing 0.7% (w/w) BHA for 7 d. The level of Prx I mRNA in these tissues similarly increased more than 2-fold, corroborating that induction of Prx I by BHA is controlled at the transcriptional level. Results from Nrf2-deficient mice underscore that Nrf2 is the major factor that controls the activation of the Prx I gene as well as genes encoding other detoxifying enzymes, such as GSTs, NAD(P)H:quinone reductase, UDP-glucuronosyl-transferases, and epoxide hydrolases (Itoh *et al.*, 1997; Ishii *et al.*, 2002).

## 3. STRESS INDUCTION OF OTHER Prxs

### 3.1. Stress Induction of Prx III

Oxidative stress also up-regulates the Prx III expression level, both *in vitro* and *in vivo*. Up-regulation of Prx III (SP-22), a mitochondrial Prx, by various agents was demonstrated in bovine aortic endothelial cells (Araki *et al.*, 1999). Supplementing the medium with  $\text{Fe}^{2+}$  together with DTT, which produces the hydroxyl radical through the Fenton reaction, increased Prx III mRNA 2.0-3.5-fold at 3–6 h and the protein level 1.9-4.6-fold at 24 h. In addition to  $\text{Fe}^{2+}$  plus DTT,  $\text{H}_2\text{O}_2$ , the superoxide-producing agents, sodium arsenite and cadmium chloride similarly enhanced Prx III expression. Notably, supplementation of the culture medium with antimycin A, a respiratory inhibitor that induces mitochondrial superoxide production (Loschen *et al.*, 1974), enhanced the expression of Prx III as effectively as  $\text{Fe}^{2+}$  plus DTT. An enhanced Prx III expression *in vivo* was demonstrated by immunostaining in an experimental model of rat myocardial infarction. The level of Prx III expression peaked at 24 h and rapidly decreased at 48 h after ligation of the left descending coronary artery (Araki *et al.*, 1999). The molecular mechanism of the transcriptional regulation of the Prx III gene has yet to be studied.



### 3.2. Activation of Prx II Gene Expression by Radiation

The testis is one of the most sensitive organs to ionizing radiation. The irradiation of mice with X-rays causes oxidative stress resulting in the up-regulation of Prx I and II in testis (Lee *et al.*, 2002). Prx I is preferentially expressed in the Leydig cells and Prx II in the Sertoli cells in mouse testis. Neither Prx I nor Prx II is expressed in germ cells, including spermatogonia and spermatocytes. The response of testis to X-ray was investigated in male adult C57BL/6 mice irradiated with 4 MV X-ray with a dose rate of 0.2 Gy/min. The GSH content of testis decreased immediately after irradiation and recovered after 2 to 6 h. Peroxidized lipids increased linearly for 2 h after irradiation and gradually decreased to normal levels after 24 h. The expression levels of both Prx I and Prx II increased 4-fold 6 h after irradiation and returned to normal by 24 h. (Lee *et al.*, 2002).

## 4. CONCLUSIONS

In addition to catalase and glutathione peroxidases (Brigelius-Flohé, 2006), Prxs play an important role in eliminating  $H_2O_2$ , which leads to the production of reactive oxygen-centered radicals in the presence of free  $Fe^{2+}$ . Up-regulation of Prx I in cells and tissues by various electrophilic agents or oxidative stimuli is widely observed, suggesting an important role of Prx I in the cellular defense against oxidants. Up-regulation of the Prx family proteins should generally increase the cellular capacity to combat  $H_2O_2$ -induced oxidative damage. However, we should be careful not to overestimate the role of individual members of the antioxidant defense system. Prx I-null and wild-type mice only show a small difference in protection against the free-radical-producing agent, Fe-NTA (Uwayama *et al.*, 2005). It is also worth to note that up-regulation of Prxs usually occurs after oxidative damage, *i.e.* during the recovery processes. It is likely, therefore, that Prxs act in concert with each other and the realm of other antioxidant enzymes and proteins, thus contributing in more or less specific ways to the overall response to oxidative challenges.

## ACKNOWLEDGMENTS

The authors thank Drs. K. Nakaso, E. Warabi, J. Uwayama, M. Yamamoto, K. Itoh, R. Siow, and G. E. Mann, for helpful discussion. The research described was supported by the Japan Society for the Promotion of Science.

## REFERENCES

- Araki, M., Nanri, H., Ejima, K., Murasato, Y., Fujiwara, T., Nakashima, Y., Ikeda, M., 1999, Antioxidant function of the mitochondrial protein SP-22 in the cardiovascular system. *J. Biol. Chem.* **274**: 2271–2278.
- Banning, A., Deubel, S., Kluth, D., Zhou, Z., Brigelius-Flohé, R., 2005, The GI-GPx gene is a target for Nrf2. *Mol. Cell. Biol.* **25**: 4914–4923

- Brigelius-Flohé, R., 2006, Glutathione peroxidases and redox-regulated transcription factors. *Biol. Chem.* **387**: 1329–1335.
- Chang, TS., Jeong, W., Choi, SY., Yu, S., Kang, SW., Rhee, SG., 2002, Regulation of peroxiredoxin I activity by Cdc2-mediated phosphorylation. *J. Biol. Chem.* **277**: 25370–25376.
- Cho, HY., Jedlicka, AE., Reddy, SP., Zhang, LY., Kensler, TW., Kleeberger, SR., 2002a, Linkage analysis of susceptibility to hyperoxia. Nrf2 is a candidate gene. *Am. J. Respir. Cell Mol. Biol.* **26**: 42–51.
- Cho, HY., Jedlicka, AE., Reddy, SP., Kensler, TW., Yamamoto, M., Zhang, LY., Kleeberger, SR., 2002b, Role of NRF2 in protection against hyperoxic lung injury in mice. *Am. J. Respir. Cell Mol. Biol.* **26**: 175–182.
- Das, KC., Pahl, PMB., Guo, X-L., White, CW., 2001, Induction of peroxiredoxin gene expression by oxygen in lungs of newborn primates. *Am. J. Respir. Cell Mol. Biol.* **25**: 226–232.
- Hess, A., Wijayanti, N., Neuschafer-Rube, AP., Katz, N., Kietzmann, T., Immenschuh, S., 2003, Phorbol Ester-dependent Activation of Peroxiredoxin I Gene Expression via a Protein Kinase C, Ras, p38 Mitogen-activated Protein Kinase Signaling Pathway. *J. Biol. Chem.* **278**: 45419–45434.
- Huang, HC., Nguyen, T., Pickett, CB., 2000, Regulation of the antioxidant response element by protein kinase C-mediated phosphorylation of NF-E2-related factor2. *Proc. Natl. Acad. Sci. USA* **97**: 12475–12480.
- Huang, HC., Nguyen, T., Pickett, CB., 2002, Phosphorylation of Nrf2 at Ser-40 by protein kinase C regulates antioxidant response element-mediated transcription. *J. Biol. Chem.* **277**: 42769–42774.
- Immenschuh, S., Iwahara, S., Satoh, H., Nell, C., Katz, N., Müller-Eberhard, U., 1995, Expression of the mRNA of heme-binding protein 23 is coordinated with that of heme oxygenase-1 by heme and heavy metals in primary rat hepatocytes and hepatoma cells. *Biochemistry* **34**: 13407–13411.
- Immenschuh, S., Iwahara, S., Schwennen, B., 2002, Induction of heme-binding protein 23/peroxiredoxin I gene expression by okadaic acid in cultured rat hepatocytes. *DNA Cell Biol.* **4**: 347–354.
- Ishii, T., Yamada, M., Sato, H., Matsue, M., Taketani, S., Nakayama, K., Sugita, Y., Bannai, S., 1993, Cloning and characterization of a 23-kDa stress-induced mouse peritoneal macrophage protein. *J. Biol. Chem.* **268**: 18633–18636.
- Ishii, T., Kawane, T., Taketani, S., Bannai, S., 1995, Inhibition of the thiol-specific antioxidant activity of rat liver MSP23 protein by hemin. *Biochem. Biophys. Res. Commun.* **216**: 970–975.
- Ishii, T., Itoh, K., Takahashi, S., Sato, H., Yanagawa, T., Katoh, Y., Bannai, S., Yamamoto, M., 2000a, Transcription factor Nrf2 coordinately regulates a group of oxidative stress-inducible genes in macrophages. *J. Biol. Chem.* **275**: 16023–16029.
- Ishii, T., Itoh, K., Akasaka, J., Yanagawa, T., Takahashi, S., Yoshida, H., Bannai, S., Yamamoto, M., 2000b, Induction of murine intestinal and hepatic peroxiredoxin MSP23 by dietary butylated hydroxyanisole. *Carcinogenesis* **21**: 1013–1016.
- Ishii, T., Itoh, K., Yamamoto, M., 2002, Roles of Nrf2 in Activation of antioxidant enzyme genes via antioxidant responsive elements. *Methods in Enzymology* **348**: 182–190.
- Ishii, T., Itoh, K., Ruiz, E., Leake, D.S., Unoki, H., Yamamoto, M., Mann, G.E. 2004, Role of Nrf2 in the regulation of CD36 and stress protein expression in m urine macrophages: activation by oxidatively modified LDL and 4-hydroxynonenal. *Circ. Res.* **94**: 609–616.
- Itoh, K., Chiba, T., Takahashi, S., Ishii, T., Igarashi, K., Katoh, Y., Oyake, T., Hayashi, N., Satoh, K., Hatayama, I., Yamamoto, M., Nabeshima, Y., 1997, An Nrf2/small Maf heterodimer mediates the induction of phase II detoxifying enzyme genes through antioxidant response elements. *Biochem. Biophys. Res. Commun.* **236**: 313–322.
- Itoh, K., Mochizuki, M., Ishii, Y., Ishii, T., Shibata, T., Kawamoto, Y., Kelly, V., Sekizawa, K., Uchida, K., Yamamoto, M., 2004, Transcription factor Nrf2 regulates inflammation by mediating the effect of 15-deoxy-delta(12,14)-prostaglandin J2. *Mol. Cell. Biol.* **24**: 36–45.
- Iwahara, S., Satoh, H., Song, D.X., Webb, J., Burlingame, A.L., Nagae, Y., Muller-Eberhard, U., 1995, Purification, characterization, and cloning of a heme-binding protein (23 kDa) in rat liver cytosol. *Biochemistry* **34**: 13398–13406.
- Kim HS., Kang SW., Rhee, SG., Clerch, LB., 2001, Rat lung peroxiredoxins I and II are differentially regulated during development and by hyperoxia. *Am. J. Physiol. Lung Cell Physiol.* **280**: L1212–L1217.

- Kim, HS., Manevich, Y., Feinstein, SI., Pak, JH., Ho, YS., Fisher, A.B., 2003, Induction of 1-Cys Peroxiredoxin expression by oxidative stress in lung epithelial cells. *Am. J. Physiol. Lung Cell Mol. Physiol.* **285**: L363–369.
- Kinnula, VL., Lehtonen, S., Kaarteenaho-Wiik, R., Lakari, E., Paakko, P., Kang, SW., Rhee, SG., Soini, Y., 2002, Cell specific expression of Peroxiredoxins in human lung and pulmonary sarcoidosis. *Thorax* **57**: 157–164.
- Lee, K., Park, JS., Kim, YJ., Lee, YS., Hwang, TS., Kim, DJ., Park, EM., Park, YM., 2002 Differential expression of Prx I and their up-regulation by radiation. *BBRC* **296**: 337–342.
- Li, B., Ishii, T., Tan, CP., Soh, JW., Goff, SP., 2002, Pathways of Induction of Peroxiredoxin I Expression in Osteoblasts. *J. Biol. Chem.* **277**: 12418–12422.
- Li, B., Wang, X., Rasheed, N., Hu, Y., Boast, S., Ishii, T., Nakayama, K., Nakayama, KI., Goff, SP., 2004, Distinct roles of c-Abl and Atm in oxidative stress response are mediated by protein kinase C delta. *Genes Dev.* **18**: 1824–1837.
- Loschen, G., Azzi, A., Richter, Ch., and Flohé, L., 1974, Superoxide radicals as precursors of mitochondrial hydrogen peroxide. *FEBS Lett.* **42**: 68–72.
- Nakaso, K., Kitayama, M., Mizuta, E., Fukuda, H., Ishii, T., Nakashima, K., Yamada, K., 2000, Co-induction of heme oxygenase-1 and peroxiredoxin I in astrocytes and microglia around hemorrhagic region in the rat brain. *Neurosci. Lett.* **293**: 49–52.
- Prester, T., Holtzclaw W.D., Zhang, Y., Talalay, P., 1993, Chemical and molecular regulation of enzymes that detoxify carcinogens. *Proc. Natl. Acad. Sci. USA* **90**: 2965–2969.
- Primiano, T., Sutter, T.R., Kensler, T.W., 1997, Antioxidant-inducible genes. *Adv. Pharmacol.* **38**: 293–328.
- Prosperi, M. T., Ferbus, D., Karczinski I., Goubin, G., 1993, A human cDNA corresponding to a gene over-expressed during cell proliferation encodes a product sharing homology with amoebic and bacterial proteins. *J. Biol. Chem.* **268**: 11050–11056.
- Sun, L., Brand, M., Zenke, Y., Tashiro, S., Groudine, M., Igarashi, K., 2004, Heme regulates the dynamic exchange of Bach1 and NF-E2-related factors in the Maf transcription factor network. *Proc. Natl. Acad. Sci. USA* **101**: 1461–1466.
- Wen, S.T., Van Etten, R.A., 1997, The PAG gene product, a stress-induced protein with antioxidant properties, is an Abl SH3-binding protein and a physiological inhibitor of c-Abl tyrosine kinase activity. *Genes & Dev.* **11**: 2456–2467.

## INDEX

- A2 antioxidant defense, 317  
*Acinetobacter baumannii*, 178  
*Actinobacillus*, 177, 178  
*Actinobacillus pleuropneumoniae*, 171, 177, 178  
Active site, 8, 9, 14, 41, 43, 45, 46, 48–51, 53, 54, 61–65, 67–76, 93, 98, 115, 121, 126, 127, 129, 137, 146, 169, 173, 174, 178, 179, 211, 223, 225, 226, 238, 241–243, 245, 302, 339, 363  
*Aeropyrum peris*, 12  
*Aeropyrum pernix*, 28, 32, 34, 43, 46, 55, 57, 69, 310  
*Agrobacterium*, 134  
*Agrobacterium tumefaciens*, 165, 171, 174–176  
AhpC, 2, 4–6, 13, 14, 17, 28, 32, 33, 44, 46, 51, 53, 54, 62, 66–68, 70, 71, 73–75, 85, 90, 93, 97, 100–103, 107, 116, 117, 135, 136, 143, 146–155, 157–170, 195, 207–210, 212, 214, 244, 272, 301, 309, 310  
AhpF, 195, 196, 198, 201–203, 207, 209, 212  
Alkyl hydroperoxide reductase, 2, 4, 33, 84, 92, 100, 195–197, 207, 208, 310  
*Alternaria alternata*, 282  
Alzheimer's disease (AD), 299, 300, 357–364, 366–370  
*Amphibacillus*, 197, 198, 200–203  
*Amphibacillus xylanus*, 14, 43, 195–199, 201–203, 310  
Amylotrophic lateral sclerosis (ALS), 357–359  
*Anopheles gambiae*, 36  
Antioxidant defence, 1, 7, 8, 10, 15, 17, 207, 212–214, 267, 269, 277, 278, 284, 286, 295, 296, 300, 301, 303, 308, 309, 349, 352  
Antioxidant defence systems, 8, 213, 214, 267, 269, 277, 278, 284, 295, 300, 309  
Antioxidant enzyme, 27, 33–36, 61, 76, 210, 219, 220, 298, 301, 307, 331, 332, 345–348, 350, 366, 368, 375, 382  
AP-1-like transcription factors, 132, 253, 255  
Apoptosis, 9, 15, 254, 268, 296, 298, 300, 302–304, 331, 345, 348, 369, 376, 379  
*Arabidopsis*, 121, 122, 133, 134, 270, 274, 278, 280, 282, 284–286  
*Arabidopsis halleri*, 281, 286  
*Arabidopsis thaliana*, 28, 31, 32, 35, 121, 267, 271–273, 278–281, 285, 286  
Archaea, 4, 27, 28, 32–35, 146  
Arsenic, 375, 378–380  
Ascorbate, 107, 145, 231, 232, 246, 247, 269, 270, 279, 280, 282–284, 286  
*Bacillus subtilis*, 150, 155, 157–159, 162–164, 171, 174–177, 208  
Bacteria, 2, 17, 27–29, 33, 67, 117, 120, 121, 132, 143–145, 155, 161, 163, 164, 166, 172, 173, 175, 182, 183, 195, 196, 201–203, 207, 208, 210, 212, 253, 272, 284  
*Bacteroides*, 152  
*Bacteroides fragilis*, 150, 155, 163, 164, 167  
*Bos taurus*, 43, 51  
*Botrytis cinerea*, 282  
*Brassica*, 282  
*Brugia malayi*, 36  
*Burkholderia pseudomallei*, 166  
*Caenorhabditis elegans*, 121, 212, 298  
*Campylobacter jejuni*, 150, 157, 158, 163  
*Candida albicans*, 261, 262  
Cell signaling, 72, 115, 132, 268, 287, 289  
Central nervous system, 300, 357  
*Chlamydia*, 166  
Chloroplast, 11, 31, 34, 35, 65, 68, 72, 74, 121, 133, 134, 267–271, 273–280, 282–285, 288, 289  
Conformational change, 41, 45, 54, 55, 61, 76, 96, 127, 137, 147–149, 174, 175, 243, 285, 298, 307  
*Corynebacterium diphtheriae*, 148  
*Crithidia*, 6  
*Crithidia fasciculata*, 5, 43, 65, 71, 85, 89, 90, 92, 108, 116, 121, 232, 310  
*Cryptococcus neoformans*, 262

- Cysteine sulfinic acid, 29, 31, 32, 61, 64, 69, 84, 115, 117, 119, 146, 173, 318, 323, 325, 328  
 Cysteine thiol, 61, 143, 173, 299
- Deinococcus radiodurans*, 173, 307  
*Dirofilaria immitis*, 36  
 DNA damage, 119, 168, 253, 254, 261  
*Drosophila*, 121, 122  
*Drosophila melanogaster*, 28, 32, 36, 212, 352  
 Drug development, 207, 219, 220, 227  
 Drug discovery, 213
- Electrophile, 375–378  
 Embryogenesis, 345, 352  
 Embryonic development, 349, 350, 352  
*Entamoeba histolytica*, 11, 233  
*Enterococcus faecalis*, 150, 158, 159, 163, 171, 177  
 Enzyme-linked, 295  
*Eubacterium acidamidophilum*, 6  
*Euglena gracilis*, 233  
 Eukaryotes, 2, 27, 28, 31, 32, 34, 54, 115, 253, 257, 260, 261, 266, 267, 270, 309  
 Excitotoxicity, 357, 359, 362, 369
- Fusarium solani*, 282
- Gametogenesis, 345, 349, 352  
 Gene expression, 134, 253, 255–259, 262, 263, 278, 279, 282, 283, 288, 289, 349, 366, 375–382  
 Gene regulation, 143, 146, 148, 149, 155, 157, 182, 283, 286, 287, 317  
*Gentiana triflora*, 278, 282  
*Glossina morsitans*, 352  
 Glutathione peroxidase, 5–10, 29, 35, 36, 61, 84, 87, 93, 107, 108, 207, 219, 220, 224, 231, 232, 234, 235, 238–247, 271, 281, 300, 301, 318, 325, 327, 329, 331, 345, 352, 376, 377, 382  
 Glutathione, 5, 7, 17, 29, 30, 32, 37, 71, 107, 108, 128, 136, 145, 148, 158, 207, 212, 213, 221, 222, 226, 231, 233, 246, 267–271, 273, 280, 300, 301, 323, 324, 349  
 Glutathione S-transferase, 6, 71, 219–222, 227, 376, 381
- H<sub>2</sub>O<sub>2</sub>, 5, 15, 30, 83, 84, 92, 93, 97, 99, 133, 134, 143–146, 149, 152–159, 161, 163–170, 172, 173, 177, 195, 198, 202, 239, 253, 256, 258, 259, 270, 287, 295, 300, 302, 303, 304, 308–310, 317, 329, 369
- Haemophilus influenzae*, 43, 51, 55, 70, 71, 211, 310  
*Helicobacter pylori*, 17, 43, 85, 90, 101, 103, 135, 136, 147, 151, 159, 164–168, 171, 172  
*Homo sapiens*, 28, 31, 32, 43, 236  
*Hordeum vulgare*, 278, 281  
 Hydrogen peroxide, 7, 9, 27, 29, 30, 34–37, 44, 54, 62, 65, 66, 72, 84, 96, 99, 101, 105, 116–119, 143, 195, 197–199, 203, 207, 232, 233, 239, 245–247, 268–270, 274, 282, 285, 287, 288, 296, 298, 299, 307, 345, 350, *see also* Hydroperoxide; H<sub>2</sub>O<sub>2</sub>  
 Hydroperoxide, 6, 8, 44, 62, 66, 67, 83, 84, 89, 92, 93, 95, 98, 105, 106, 146, 149, 153, 154, 161, 168, 173, 177–179, 182, 197–199, 203, 208–211, 213, 214, 223, 225, 231, 232, 239–241, 244–246, 272, 276, 282, 287, 288, 297, 318, 322, 325, 326, 328, 331, 358  
 Hyperoxia, 300, 321, 351, 375, 380  
 HypR, 143, 150, 158, 159, 163
- Insects, 36, 71, 232, 246, 345, 352  
 Involvement in H<sub>2</sub>O<sub>2</sub>-mediated signaling, 295
- Kinetics, 66, 83, 84, 86, 89, 93, 94, 97, 99, 101–103, 105, 197, 225, 226, 239, 246, 279
- L. viannia*, 244  
*Legionella*, 166  
*Legionella pneumophila*, 151, 162, 163, 166, 167  
*Leishmania*, 6, 17, 35, 71, 213, 219, 220, 231–233, 244, 245  
*Leishmania amazonensis*, 244, 245  
*Leishmania chagasi*, 101, 238, 239  
*Leishmania donovani*, 65, 85, 90, 116, 231, 234, 236, 238–241  
*Leishmania infantum*, 85, 90, 95, 235, 236, 239, 240  
*Leishmania major*, 116, 231, 233–236, 246, 247  
*Leishmania (V.) guyanensis*, 244  
 Leishmaniasis, 16, 231, 244  
*Leptosphaeria maculans*, 282  
 Local unfolding, 41, 43, 45, 47, 50, 53–55, 57, 61, 63, 72, 75, 76, 127, 244, 277, 328
- Lung  
 disease, 317, 321, 337, 380  
 surfactant, 317, 321, 335, 337
- Macrophage, 2, 3, 144, 151, 160, 166, 167, 207, 212, 219, 244, 257, 261, 317, 320, 337, 375–380

- Malaria, 17, 34, 219–221, 227
- Mammals, 3, 7, 16, 29, 31, 35–37, 120, 212, 214, 227, 254, 275, 301, 345, 368
- Melampsora larici-populina*, 281
- Mesothelioma, 317, 318
- Mitochondria, 1, 3, 6, 34–36, 108, 129, 224, 227, 295–297, 299–301, 303, 309, 320, 358–361
- Mitochondrion, 231, 245, 267, 269, 272
- Mycobacteria*, 17, 71, 148, 152, 154, 160, 161, 166, 167, 207, 208, 210, 212
- Mycobacteria avium*, 150, 154, 161
- Mycobacteria intracellular*, 150, 154
- Mycobacteria leprae*, 154
- Mycobacteria marinum*, 150, 154, 159
- Mycobacteria smegmatis*, 150, 154, 166
- Mycobacteria xenopi*, 150, 154
- Mycobacterium bovis*, 151, 159, 160, 167, 170
- Mycobacterium tuberculosis*, 6, 12, 14, 43, 51, 55, 74, 85, 90, 92, 93, 97, 101, 103, 104, 106, 107, 147, 151, 159–161, 163, 165–167, 169–171, 207, 208, 210, 212–214, 304, 310
- NADH oxidase, 161, 195–203
- Neurodegeneration, 351, 357, 368
- Neuroprotection, 366, 369
- Nrf2, 375–382
- Ohr, 143, 146, 164, 171, 173–179
- OhrR, 143, 164, 171, 174–178
- Oligomerization, 12, 15, 61, 62, 73–76, 200, 223, 226
- Onchocerca ochengi*, 36
- Onchocerca volvulus*, 36
- Organic peroxide, 143, 144, 146, 149, 154, 163–166, 168, 169, 170, 173–175, 179, 182, 223, 300, 301
- Oryza sativa*, 35, 271
- Osmotically inducible protein (OsmC), 143, 146, 163, 173, 177–182
- Oxidative inactivation, 9, 54, 61, 65, 71, 75, 95, 96, 106
- Oxidative stress, 7, 8, 16, 72, 84, 115, 116, 119, 121, 132, 134–137, 143, 145, 146, 148, 149, 153, 157, 158, 160–165, 168, 170, 172, 175, 182, 207, 219, 220, 223, 226, 275, 278, 279–282, 295, 296, 298–302, 306, 317, 322, 329, 331, 337, 338, 346, 347, 349, 351, 357, 358, 362, 363, 366, 375, 377, 378, 380–382
- OxyR, 143, 148–155, 159–161, 163, 164, 167
- Parkinson's disease (PD), 299, 300, 357, 358, 362, 363, 370
- Peroxidase, 2, 4–8, 10, 12, 14, 17, 27, 29–31, 33, 66, 74, 84, 85, 89, 93, 95, 97–99, 101–104, 106–108, 115, 116, 127, 134–136, 168–170, 173, 174, 179, 197–199, 201, 207, 208, 210, 211, 213, 214, 219, 220, 223, 224, 231, 232, 234, 238–247, 253–255, 257–261, 267, 269–271, 273, 274, 277, 279, 281, 282, 284, 286–288, 300, 301, 306, 308, 310, 317, 318, 321–327, 329–331, 335, 345–347, 350, 352, 376, 377
- Peroxide-linked redox signalling, 8
- Peroxide reduction, 31, 33, 62, 64, 65, 73–75, 197, 274
- Peroxide sensing, 132, 133, 143, 148, 155, 164, 174
- Peroxioredoxins (Prxs)
- in archaea, 34
  - in bacteria, 208
  - catalytic cycle of, 41, 45, 86, 275, 328
  - in central nervous system, 357–370
  - chaperone function of, 134
  - classification of, 4, 28, 31, 68, 225
  - in development, 349, 352
  - discovery, 1, 4
  - enzymatic activity, 132, 223, 225
  - in eukaryotes, 27, 34, 96, 115, 263
  - evolution of, 27–40
  - families, 1, 4, 7, 12, 27, 32, 41, 116, 146, 173, 295, 301, 309, 318
  - function, 1, 31, 267, 270, 286, 289
  - in gametogenesis, 345–355
  - gene expression, 279, 283, 376
  - genes of, 27, 284
  - history of, 1
  - hyperoxidation of, 12
  - in insects, 36
  - in invertebrates, 36
  - kinetics of, 83–113
  - in lung, 317, 332, 337, 351
  - in mammals, 31, 35–37
  - medical perspectives, 15
  - membrane-association, 1, 10, 11
  - in mitochondria, 34, 303
  - and NADH oxidase, 195–205
  - neuroprotection, 369
  - oligomeric state, 73, 137, 308
  - overoxidation, 63, 72, 117
  - and peroxinitrite detoxification, 101, 107, 289
  - in plants, 285
  - in protozoa, 34
  - reductase, 147, 148, 195

- repair proteins, 115–141  
 stress-induced, 375–384  
 structure, 1, 25, 41, 47, 49, 51, 57, 58, 72, 116,  
 128, 169, 214, 242, 269, 305, 307, 309  
 in yeast, 253–265
- Peroxynitrite, 8, 31, 33, 35, 36, 62, 67, 83, 84,  
 100–109, 116, 143, 144, 146, 163, 165, 166,  
 169, 172, 208, 210, 212, 213, 223, 233, 239,  
 272, 287, 288, 298, 300, 301, 366, 369
- PerR, 143, 150, 155–159, 162–164
- Phospholipase, 317, 318, 321, 322, 327,  
 333–337, 339, 349, 352
- Phospholipid, 7, 66, 245, 317, 318, 325–327,  
 339, 351
- Photosynthesis, 133, 267–271, 276, 278,  
 282–286
- Placenta, 351
- Plants, 27–29, 31, 35, 133, 134, 212, 246, 263,  
 267–269, 271–275, 277, 279–282,  
 284–286, 289
- Plasmodia*, 219
- Plasmodium*, 17, 219–223, 225–227
- Plasmodium berghei*, 223
- Plasmodium falciparum*, 15, 28, 32, 34, 35, 43,  
 69, 72, 85, 90, 101–103, 212, 219–227,  
 245, 310
- Plasmodium vivax*, 43
- Plasmodium yoelii*, 43, 223
- Populus trichocarpa*, 43, 271, 281
- Porphyrromonas*, 152
- Porphyrromonas gingivalis*, 150, 154, 155,  
 163, 167
- Presenilin-1, 3, 369
- Protein oxidation, 170, 253, 298, 359, 369
- Protein structure, 41, 222
- Protozoal parasite, 219, 220
- Prx discovery, 1
- PrxI, 3, 12, 13, 15, 28, 32, 44, 54, 74, 75,  
 116–118, 120, 128, 129, 131, 132, 135, 224,  
 307, 309, 338, 357, 360–363, 366, 369, 370
- PrxII, 2, 3, 10–14, 16, 44, 54, 64, 65, 68, 71–73,  
 75, 116–118, 120, 121, 126, 127, 129, 135,  
 223, 263, 270, 272, 277, 278, 280–282, 285,  
 286, 288, 289, 357, 360–363, 369, 370
- PrxIII, 2, 3, 12, 13, 15, 16, 44, 51, 129, 295, 296,  
 303–310, 357, 360–363, 369, 370
- PrxV, 3, 15, 28, 32, 44, 46, 49, 55, 57, 63, 68,  
 69, 71–73, 101, 129, 214, 225, 295, 296,  
 303, 304, 306–309, 318, 322, 357, 360, 361,  
 363, 369, 370
- Pseudomonas*, 152, 153
- Pseudomonas aeruginosa*, 150, 153, 163, 164,  
 171, 173, 175, 176
- Pseudomonas putida*, 150, 153, 154
- Pyrococcus horikoshii*, 34
- Radiation, 119, 145, 233, 253, 331, 338, 345,  
 375, 382
- Rattus norvegicus*, 43, 54
- Reactive oxygen species (ROS), 7, 16, 120, 133,  
 135, 143–146, 165, 207, 208, 209, 212, 220,  
 223, 253–255, 257, 260, 261, 263, 267, 268,  
 270, 279, 282, 284, 288, 295–299, 301, 304,  
 310, 329, 337, 338, 345, 347, 349–352, 358,  
 362, 363, 369, 370, 378
- Reconstitution of PrxIII pathway, 295
- Redox signalling, 8, 9, 107, 109, 238, 267
- Retroreduction, 115, 117, 123, 124, 137
- Riccia fluitans*, 282
- Saccharomyces cerevisiae*, 2, 27, 28, 32–34, 43,  
 51, 98, 103, 118, 121, 122, 236, 253–263,  
 299, 301
- Salmonella*, 6, 146, 152, 166, 198, 200, 202
- Salmonella enterica*, 196, 197, 203
- Salmonella typhimurium*, 2, 33, 43, 46, 53, 55,  
 66, 70, 73–75, 85, 90, 93, 97, 101, 103, 116,  
 117, 146, 149–151, 163, 166, 167, 208, 209,  
 236, 244, 301
- SAPK pathway, 253, 257, 258
- Sarcoidosis, 317, 338
- Schistosoma mansoni*, 54, 71, 85, 90
- Schizosaccharomyces pombe*, 117, 132, 133, 236,  
 240, 253–260, 262, 263
- Sedum lineare*, 276
- Sestrin, 31, 63, 72, 96, 115, 119–121, 129,  
 135–137
- Shewanella putrefaciens*, 163
- Signaling, 27, 29, 31, 34, 54, 72, 107, 109, 115,  
 132, 137, 235, 238, 267–269, 283, 284, 286,  
 287, 289, 303, 304, 309, 345, 348, 349, 369,  
 376, 379, 380
- Signal transduction, 8, 9, 35, 37, 46, 96, 227,  
 253–255, 257, 260, 261, 263, 283, 338, 360
- Spermatogenesis, 346
- Sporolactobacillus inulinus*, 201–203
- Staphylococcus aureus*, 150, 157, 158, 208
- Streptococci*, 161, 172
- Streptococcus gordonii*, 151, 161, 162, 171, 172
- Streptococcus mutans*, 151, 161–165, 201
- Streptococcus pneumoniae*, 43, 167, 170, 211
- Streptococcus pyogenes*, 151, 161–163, 165, 167
- Streptomyces*, 152
- Streptomyces coelicolor*, 150, 155, 161
- Streptomyces viridosporus*, 208

- Stroke, 357, 359, 366
- Structure-function relationships, 41, 46, 62, 295
- Sulfenic acid, 6, 7, 29–32, 45, 61, 63, 64, 67, 69–72, 76, 83–86, 95, 96, 99, 100, 105, 115–117, 132, 146, 148, 173–175, 211, 241, 243, 269, 270, 273, 276, 277, 318, 322, 328
- Sulfiredoxin, 31, 63, 72, 96, 109, 115, 118, 120, 122, 227, 238, 253, 254, 259, 260, 275, 276, 309, 325
- Sulfolobus solfataricus*, 34
- Surfactant, 317, 321, 333–337, 351
- Surfactant metabolism, 317, 321
- Synechocystis*, 271, 273, 280, 284
- Synechocystis elongatus*, 271, 272, 280, 284
- Thermus aquaticus*, 13, 16
- Thiol peroxidase, 2, 17, 66, 93, 133, 169, 310
- Thiol proteome, 267, 268
- Thiol-specific antioxidant protein (TSA), 2–6, 11, 27, 116, 235, 254
- Thioredoxin, 3–7
- Thioredoxin peroxidase, 2, 4, 5, 7, 70, 84, 85, 93, 98, 101–104, 106, 116, 207, 208, 210, 219, 220, 222–224, 243, 253, 255, 257, 259, 260, 301, 310
- Thioredoxin reductase, 17, 63, 94, 116, 147, 158, 209, 210, 213, 221, 231, 262, 274, 276, 301–303, 352, 360
- Torin, 1–3, 10, 11
- Toxoplasma*, 219
- Toxoplasma gondii*, 33, 64, 66, 69, 85, 90, 93, 220, 221, 226
- Tpx, 2–7, 12, 28, 32, 33, 43, 46, 48, 50, 52, 53, 55, 57, 66, 68–70, 73, 84, 85, 90, 93, 97, 98, 101–104, 106, 116, 117, 133, 143, 146, 169–172, 207, 208, 210–212, 219, 220, 223–225, 227, 243, 253, 255, 257, 259, 260, 301, 310
- Transcript regulation, 267, 277–280, 282, 283
- Transmission electron microscopy (TEM), 1, 12–14, 72, 304, 305
- Trypanosoma*, 17, 34, 71, 213, 219, 221, 231
- Trypanosoma brucei*, 85, 90, 92, 93, 95, 98, 102–105, 116, 220, 231, 233–236, 238–241, 244–246
- Trypanosoma brucei brucei*, 13, 231
- Trypanosoma brucei gambiense*, 222, 231
- Trypanosoma brucei rhodesiense*, 231
- Trypanosoma cruzi*, 43, 85, 90, 102, 103, 105, 220, 221, 231, 233–235, 238–240, 242–247, 310
- Trypanosomatidae*, 231
- Trypanosomiasis, 16
- Trypanothione, 5, 6, 17, 71, 84, 212, 221, 222, 231–247
- Tryparedoxin, 4, 6, 12, 29, 71, 83–85, 89, 92, 93, 101, 102, 105, 120, 221, 222, 231–236, 238–242, 244–246, 310
- Virulence, 16, 143, 151, 152, 166, 172, 178, 207, 213, 214, 261, 262, 338
- Xanthomonas*, 150, 152, 153
- Xanthomonas campestris*, 152, 163, 164, 171, 173–176, 178
- X-ray crystallography, 12, 14, 15, 122, 200
- Xylella fastidiosa*, 173
- Yeast, 4–7, 10, 13, 27–29, 31, 34, 35, 61, 66, 68, 69, 98, 101, 104, 116, 118, 119, 121, 125, 128–136, 168, 227



(a)

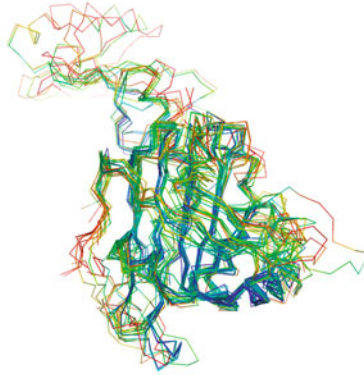

(b)

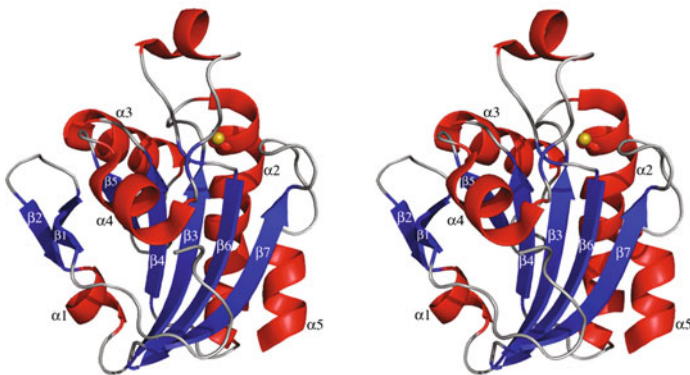

*Plate 1.* The Prx fold. (a) An overlay of all 19 fully-folded Prx structures indicating the conservation of the core of the fold. Colored by mobility with deep blue representing the least mobile portions of the chain and bright red representing the most mobile portions. (b) Stereoview of a representative fully-folded Prx (PDB code 1HD2) labeled to identify the common core  $\alpha$ -helices (red), and  $\beta$ -strands (blue) that are conserved among all Prx proteins. The peroxidatic cysteine in the first turn of helix  $\alpha 2$  is shown as a ball and stick with  $S_p$  in mustard yellow. (See Chapter 3, Figure 2, p. 47)

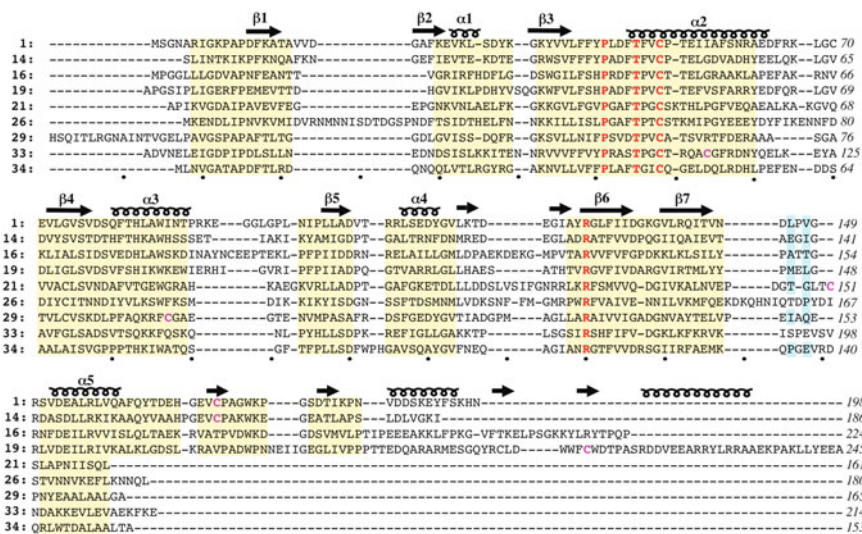
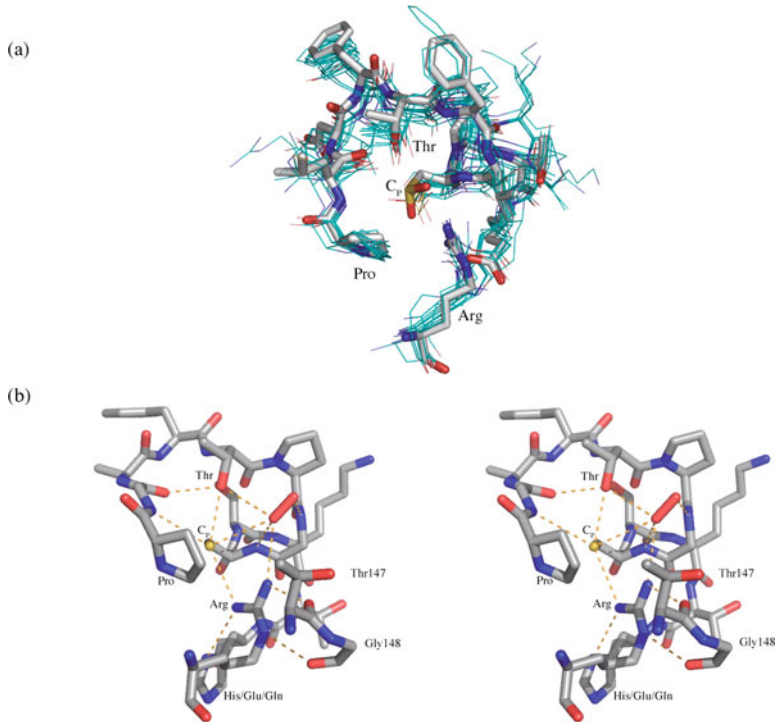
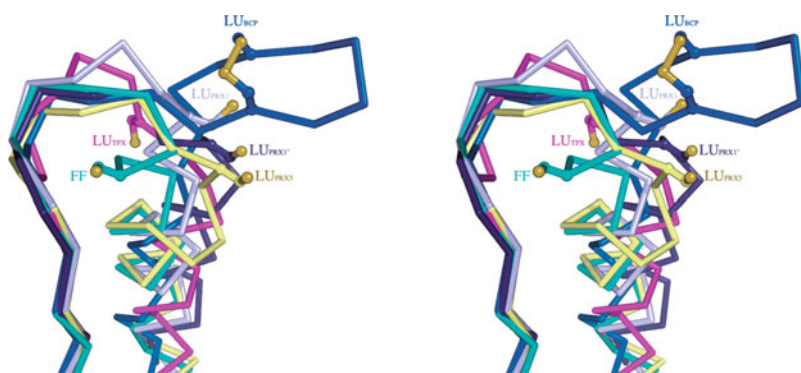

Plate 2. Structure based sequence alignment of representative Prxs. Regions of common main-chain path are highlighted by a tan background. Secondary structure elements are indicated by coils ( $\alpha$ -helices,  $3_{10}$ -helices) and arrows ( $\beta$ -strands) above the sequence, and core elements are labeled as in figure 2b. Four residues absolutely conserved are colored red and  $C_R$  of 2-Cys Prxs are colored violet. Residues involved in passing chain stabilization of the active site Arg are highlighted by a cyan background. Structures are referenced by index number from Table 1 and include in order a sensitive Prx1, a robust Prx1, a 1-Cys Prx6, a 2-Cys Prx6, a 2-Cys Prx5, a 1-Cys Prx5, a Tpx, a BCP, and the difficult to classify *MtAhpE*. Reference residue numbers are at the end of each line and for convenience, dots below the sequence highlight mark every ten spaces. Structure based sequence alignment was aided by the use of Sequoia (Brunts *et al.*, 1999). (See Chapter 3, Figure 3, p. 48)



**Plate 3.** The peroxidatic active site of Prxs. (a) An overlay of fully-folded Prx structures (thin lines with atom coloring C=cyan, N=blue, O=red, S=mustard) to indicate the high conservation of the peroxidatic active site geometry. Included are residues in the segment surrounding  $C_p$  and the conserved Arg. PDB entry 1QMV is modeled as sticks with atom coloring (C=grey, N=blue, O=red, S=yellow). (b) Stereoview of the fully-folded active site of human PrxV (Declercq *et al.*, 2001), the highest resolution structure (PDB code 1HD2). This active site has a bound molecule of benzoate, and in this figure, we have inserted a peroxide molecule close to the positions occupied by the benzoate oxygens (see text). Potential H-bonding interactions (dashed lines) are shown. In addition to the residues shown in (a), two residues (Thr147 and Gly148) from the loop between strand  $\beta 7$  and helix  $\alpha 5$  are also included as they stabilize the Arg by their peptide oxygens. In Figure 3, the residues contributing equivalent carbonyls are highlighted with a cyan background. Although not seen in the BCP structure selected for Figure 3, the other BCP structure (PDB entry 2CX4) does conserve this feature. (See Chapter 3, Figure 4, p. 49)



*Plate 4.* Local unfolding transitions of the peroxidatic active site region. Stereoview comparing the structure of the canonically fully-folded helix  $\alpha_2$  (cyan for PDB entry 1QMV) compared with a set of representative locally-unfolded  $C_p$  loops: two from subfamily Prx1 (light purple for PDB entry 1YEX and dark purple for PDB entry 2BMX), and one each from subfamilies Prx5 (yellow for PDB entry 1OC3), Tpx (magenta for PDB entry 1QXH) and BCP (dark blue for PDB entry 2CX3). The  $C_p$  residue is in each case shown as ball and stick with  $S_p$  in mustard yellow. The LU structures are all involved in disulfide bonds even though the  $C_R$  is only shown for the  $LU_{BCP}$  case. (See Chapter 3, Figure 5, p. 50)

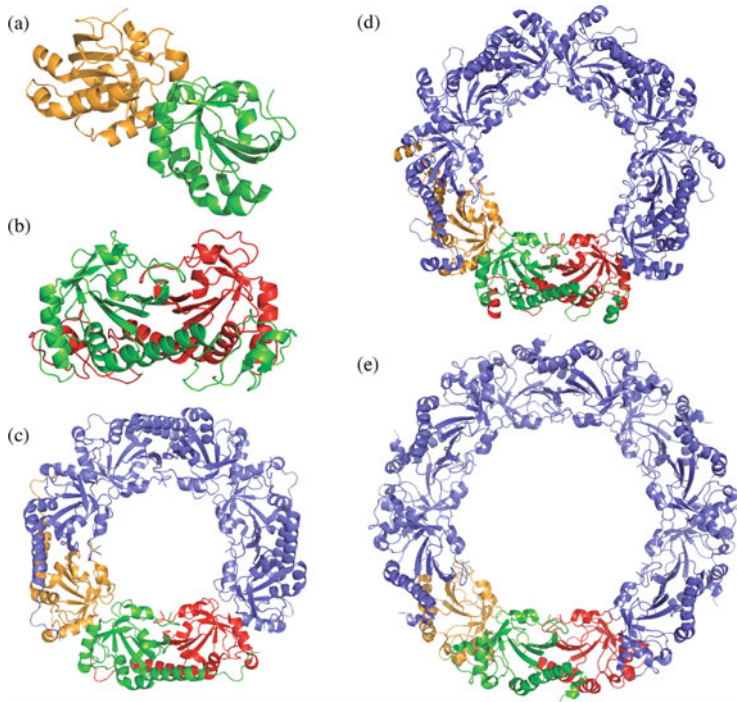

*Plate 5.* Quaternary structures of Prxs. Shown are representative structures of an (a) A-type dimer (PDB entry 1HD2), (b) B-type dimer (PDB entry 1PRX), (c) octamer (PDB entry 2H01), (d) decamer (PDB entry 1QMV) and (e) dodecamer (PDB entry 2BMX). Subunit coloring for the A-type dimer (gold and green) and the B-type dimer (green and red) are used in the higher order structures to show how they are built from these two types of interactions. The octamer, decamer and dodecamer are on the same scale and have inner diameters of  $\sim 50$  Å,  $\sim 60$  Å and  $\sim 70$  Å, respectively. (See Chapter 3, Figure 6, p. 52)

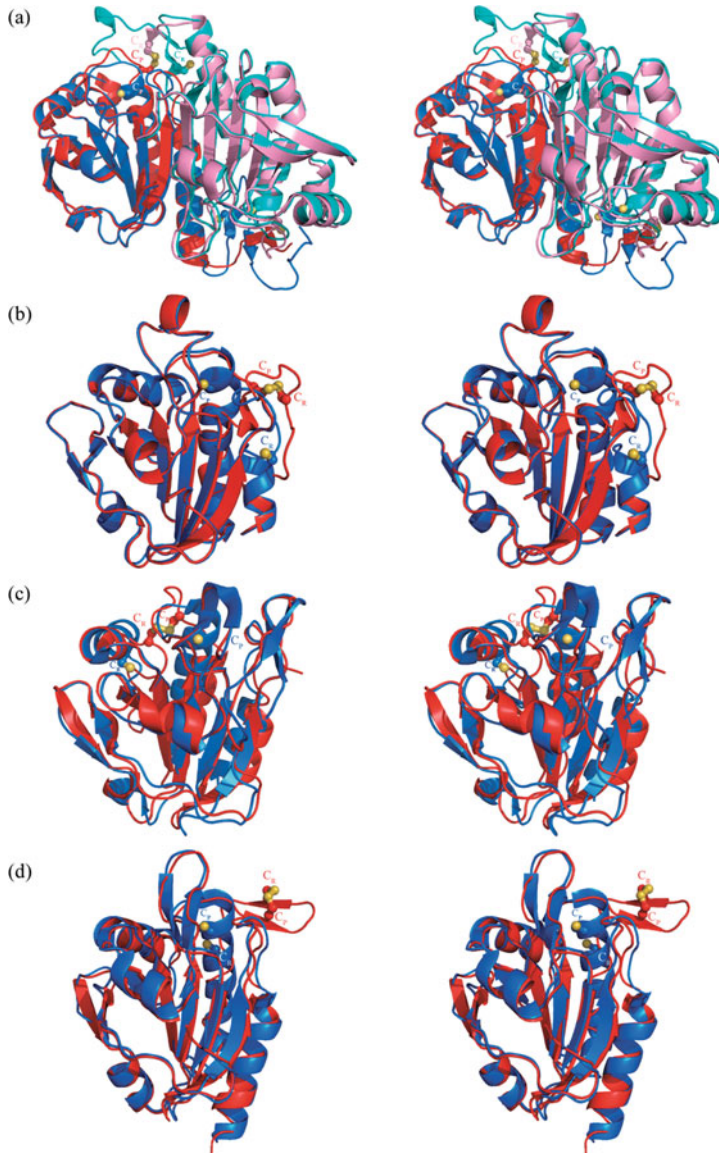

*Plate 6.* The local-unfolding conformational changes involved in resolution. Stereoviews are shown overlaying a representative fully-folded (blue tones) and locally-unfolded (red tones) structure from each of four Prx subfamilies: (a) the Prx1 subfamily represented by the B-type dimeric building block of *S. typhimurium* AhpC, with each chain of the dimer colored a distinct shade; (b) the Prx5 subfamily represented by human PrxV with an inferred locally-unfolded structure (see text); (c) the Tpx subfamily represented by *M. tuberculosis* and *H. influenzae* Tpx; (d) the BCP subfamily represented by *A. permix* BCP. The C<sub>p</sub> and C<sub>r</sub> residues are shown as ball-and-stick models in each structure with S<sub>p</sub> and S<sub>r</sub> colored mustard yellow. (See Chapter 3, Figure 7, p. 55)

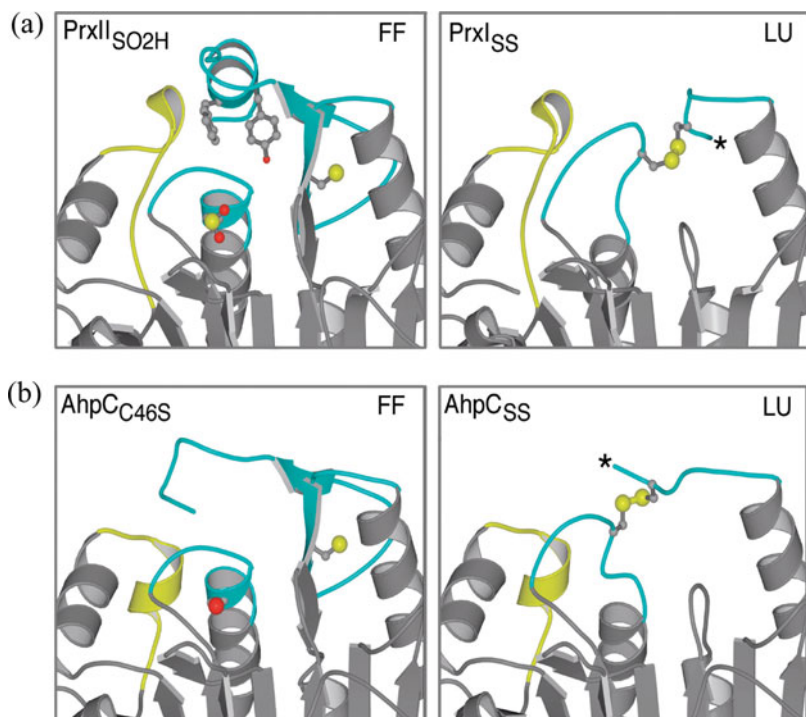

*Plate 7.* The structural difference between robust and sensitive typical 2-Cys Prxs. Views of (a) a sensitive Prx and (b) a robust Prx in the fully-folded forms (left panels) and in the locally-unfolded forms (right panels). In sensitive Prxs but not in robust Prxs, a C-terminal helix with a well conserved Tyr-Phe motif packs above the start of helix  $\alpha_2$ , and like a cork in a bottle stabilizes the fully-folded conformation, hindering its unfolding. This slows the resolution reaction and favors overoxidation by reaction with a second molecule of peroxide. In the locally-unfolded forms, an asterisk indicates the presence of additional disordered C-terminal residues. Figure reprinted from Wood *et al.* (2003a) *Science* **300**, 650–653 with permission. (See Chapter 3, Figure 8, p. 56)

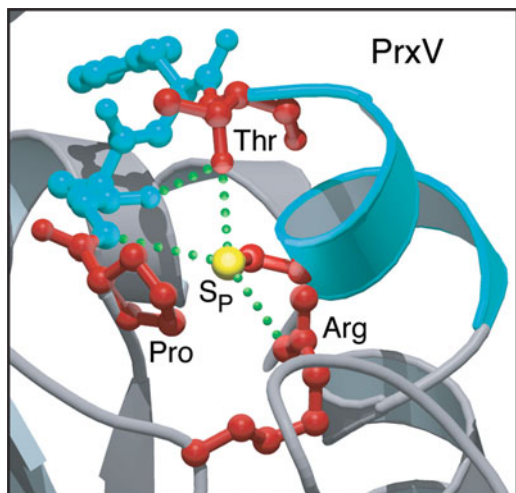

Plate 8. Conserved structure of Prx active sites. Shown in red are the conserved Pro, Thr, and Cys in the PxxTxxC active site motif, as well as the conserved Arg residue contributed by another part of the polypeptide (from human PrxV, PDB code 1hd2). Dotted lines indicate the conserved hydrogen bonding network. Blue indicates the loop-helix region around the active site that undergoes local unfolding following oxidation to form a disulfide bond in typical and atypical 2-Cys Prxs. This figure was reprinted from *Trends in Biochemical Sciences*, Vol. 28, article by Wood, Z.A., Schröder, E., Harris, J.R., and Poole, L.B., Structure, mechanism and regulation of peroxiredoxins, pages 32–40, Copyright 2003, with permission from Elsevier. (See Chapter 4, Figure 1, p. 63)

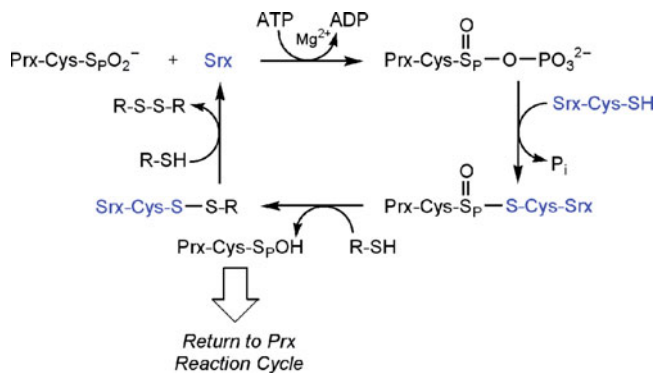

Plate 9. Proposed reaction mechanism for the reduction of the cysteine-sulfonic acid of Tsa1 by yeast Srx1. The reaction proceeds from a sulfonic acid through sulfonic phosphoryl ester and thiosulfinate intermediates (Biteau *et al.*, 2003). The position of ATP hydrolysis and the identity of the exogenous thiol (R-SH) were proposed to be between the  $\beta$ - $\gamma$  phosphate and thioredoxin, respectively. (See Chapter 6, Figure 1, p. 119)



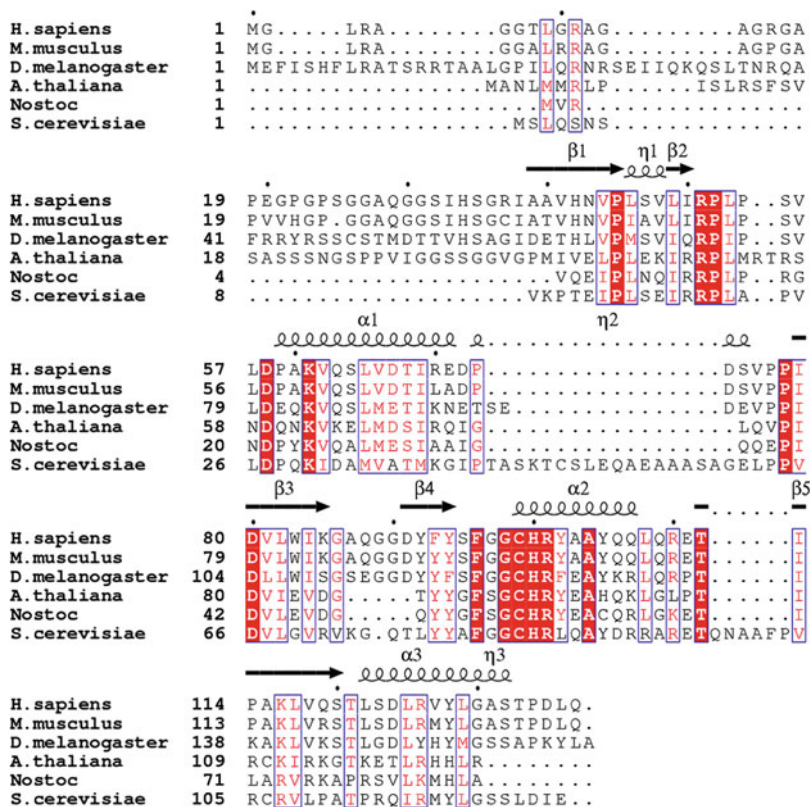
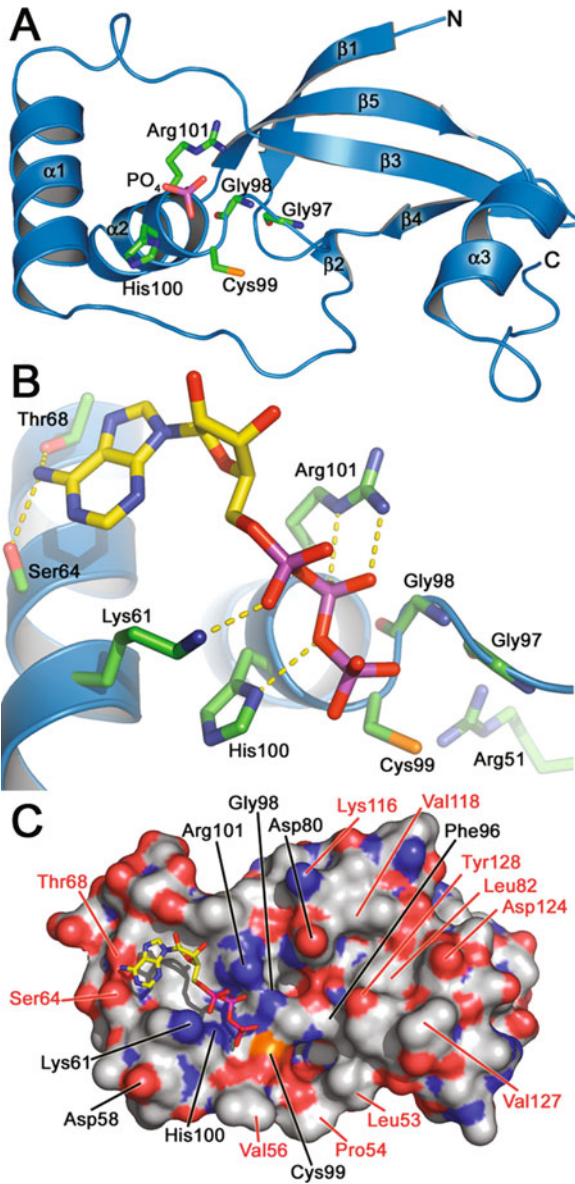
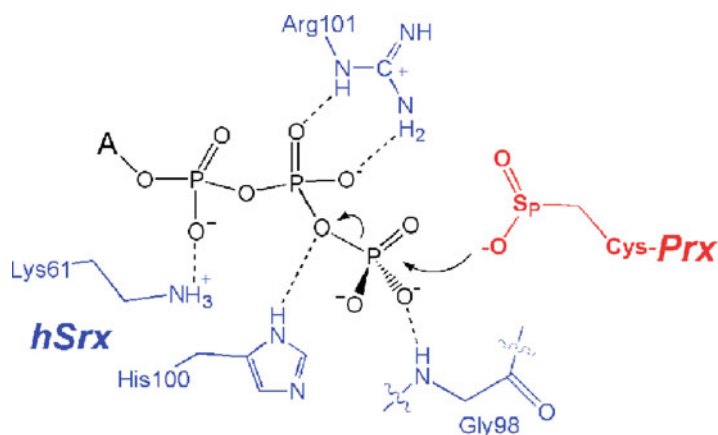

Plate 10. Sequence alignment of representative sulfiredoxins. The homology of the proteins to human Srx decreases down the alignment. The Srxs from mouse, *Drosophila*, *Arabidopsis*, *Nostoc* species PCC7120 (a cyano-bacterium), and *S. cerevisiae* show 91%, 60%, 43%, 41%, 33% sequence identity to hSrx, respectively. The secondary structural elements for human Srx are shown above the alignment:  $\alpha$ ,  $\alpha$ -helices;  $\beta$ ,  $\beta$ -strands;  $\eta$ ,  $3_{10}$  helices (See Figure 3 and section 5.1). The residues highlighted by the red background and white lettering are strictly conserved. Residues that are either conserved in the majority of the proteins or have conservative substitutions are boxed in blue and colored red. The black dots above the alignment indicate every tenth residue of human Srx. (See Chapter 6, Figure 2, p. 122)



*Plate 11.* Crystal structure of human Srx. (A) Native enzyme in complex with phosphate. The  $\alpha$ -helices and  $\beta$ -strands within the novel fold of Srx are numbered consecutively based on the primary sequence. Residues of the signature sequence of Srx are highlighted. For clarity residues 29–36 and the  $3_{10}$ -helices are not shown. Atom color scheme: green, carbon atoms for Srx; yellow, carbon atoms for ATP; red, oxygen; blue, nitrogen; magenta, phosphorus; orange, sulfur. (B) Model of ATP bound to Srx. The ATP:Srx complex is based on the crystal structure of the ADP complex. Putative hydrogen bonding interactions are indicated by dashed yellow lines. (C) Surface representation of Srx in complex with ATP. Strictly and semi-conserved residues are indicated in black and red, respectively. Carbon atoms for the Srx surface are shown in gray. (See Chapter 6, Figure 3, p. 124)



*Plate 12.* Proposed binding mode of ATP and the first step in the Srx reaction. Putative hydrogen bonding interactions are indicated by dashed lines. The nucleotide and sugar structures of the ATP molecule are abbreviated by the letter A. (See Chapter 6, Figure 4, p. 125)

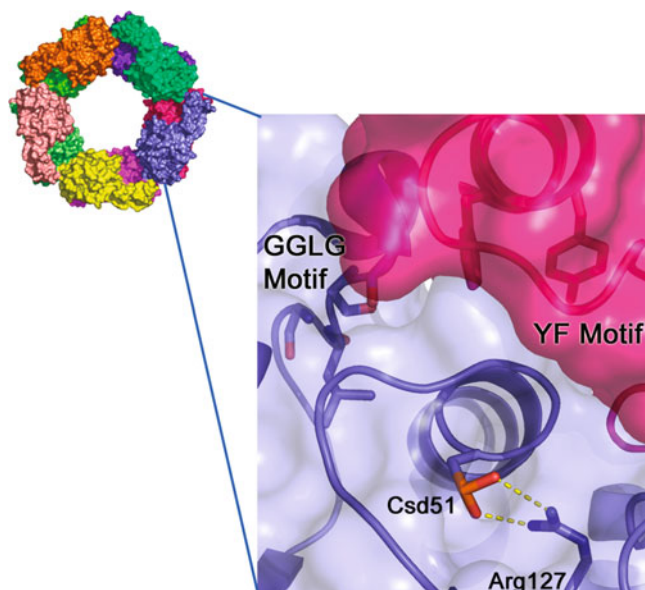

*Plate 13.* Inaccessibility of the hyperoxidized active site of human PrxII. Hyperoxidized 2-Cys Prxs form stabilized decamers. Each monomer is colored differently. A close-up view of one PrxII active sites (blue surface and ribbon) illustrates the difficulty Srx has in gaining access to the Cys51-SpO<sub>2</sub><sup>-</sup> moiety (Csd51) which is involved in a hydrogen bonding interaction with Arg127. The Prx active site is occluded primarily by residues of the YF motif within the C-terminal  $\alpha$ -helix of the adjacent Prx molecule (magenta surface and ribbon). This latter structural feature also interacts with the GGLG motif, another conserved region found primarily in Prxs sensitive to hyperoxidation. (See Chapter 6, Figure 5, p. 126)

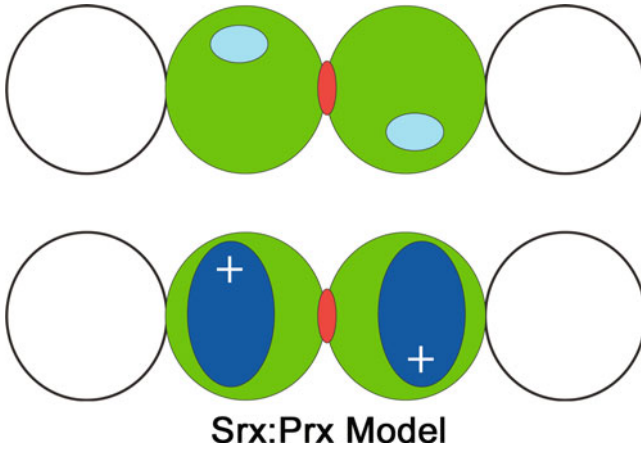

*Plate 14.* Model for the Srx:Prx interaction. The top panel indicates the edge-on view of four subunits of a Prx decamer. The active sites of the middle Prx dimer (green) are indicated in cyan. The two-fold axis is indicated by the red dyad symbol. Adjacent subunits in the Prx decamer are shown as the non-filled circles. The bottom panel illustrates the putative binding mode of Srx (blue) to the circumference of the decamer and the central Prx dimer. The Srx molecules most likely also adopt a two-fold relationship indicated by the plus signs. It is possible that the Srx molecules dock more to the side of the Prx decamer maintaining the symmetry relationship. (See Chapter 6, Figure 6, p. 127)

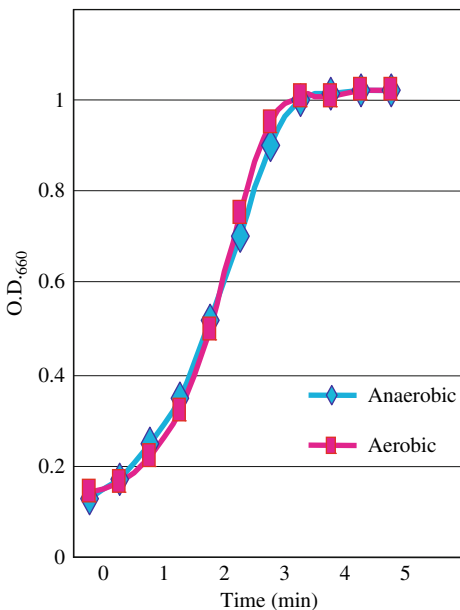

*Plate 15.* Growth of *Amphibacillus xylanus* under anaerobic and aerobic conditions. (See Chapter 8, Figure 1, p. 196)

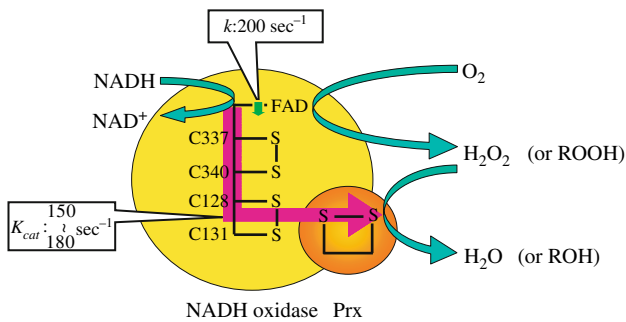

Plate 16. The NADH oxidase-Prx system shows extremely high hydroperoxide reductase activity and NADH oxidase activity. (See Chapter 8, Figure 2, p. 198)

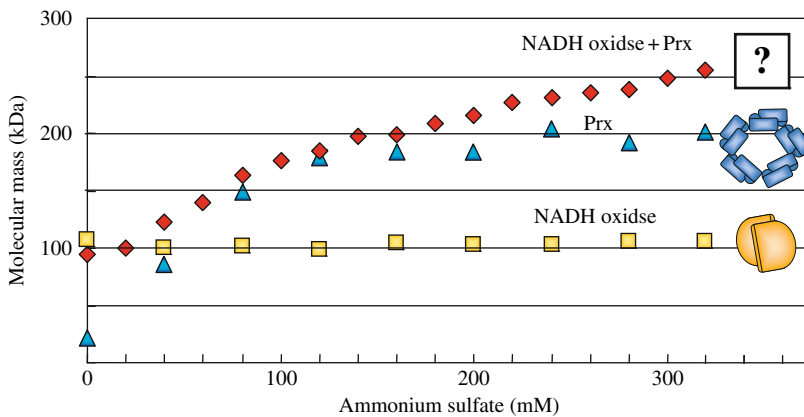
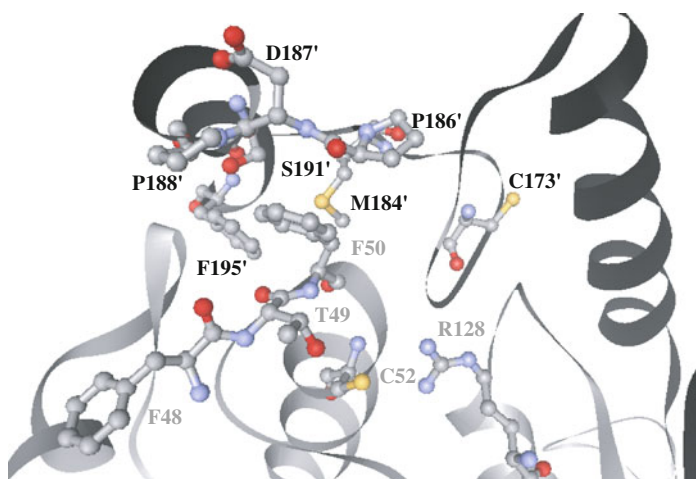
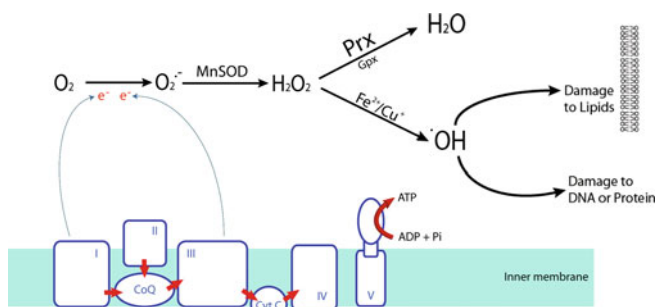

Plate 17. Large oligomeric assembly formation in the mixture of NADH oxidase and Prx determined by Dynamic Light Scattering (DLS). The ratio of NADH oxidase:Prx was 1:1 (subunit per subunit). (See Chapter 8, Figure 4, p. 200)

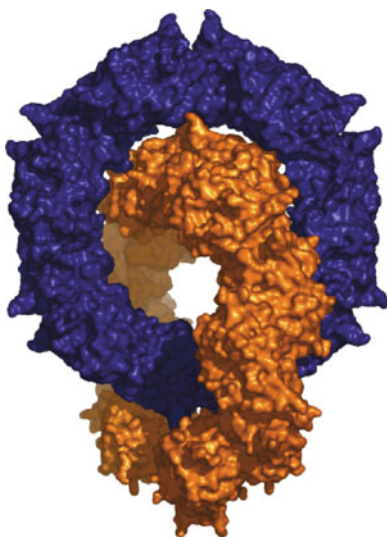

*Plate 18.* Active site of *T. cruzi* TXNPx derived from the structure of the reduced protein. One subunit of the homodimer is depicted in grey, the other one in black with primed residues. Residues that are involved in catalysis and/or subunit interaction (see section 3.4) are shown in ball and stick models. The carbon, oxygen, nitrogen and sulfur atoms are displayed in grey, red, blue and yellow, respectively. The 3-D model was generated from Protein Data Bank entry 1UUL (Pineyro et al., 2005) using the program 3D-Mol (Invitrogen). (See Chapter 11, Figure 3, p. 242)



*Plate 19.* Simplified scheme illustrating ROS production by mitochondria and relevant antioxidant systems.  $O_2$  is partially reduced to superoxide anions primarily by electron leakage from complexes I and III of the respiratory chain. Superoxide anions are reactive free radicals but can be converted to  $H_2O_2$  in the mitochondrial matrix by SOD2, MnSOD. Although  $H_2O_2$  is a mild oxidant, it can be converted to highly-damaging hydroxyl radicals via the Fenton reaction in the presence of  $Cu^+$  or  $Fe^{2+}$ . The removal of  $H_2O_2$  can be promoted by catalases, GPxs and Prxs. (See Chapter 14, Figure 1, p. 297)

a)



b)



*Plate 20.* Crystal structures of mitochondrial Prxs a) Surface diagram of the catenane structure of PrxIII C168S. The overall structure of the two interlocking rings is shown in blue and gold respectively. The figure was produced using the program PyMOL (Delano, 2002b) The crystal structure of human PrxV shown in ribbon diagram with the two oxidized dimers coloured green and red. The Cys residues taking part in intermolecular disulphide bond formation are also shown. Adapted from (Evrard *et al.*, 2004). (See Chapter 14, Figure 3, p. 306)

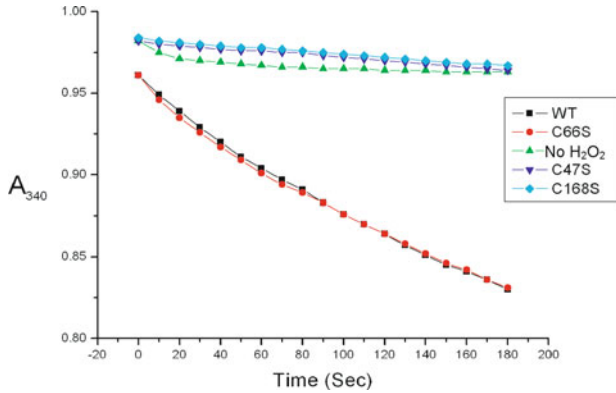

Plate 21. Time course of PrxIII-dependent NADPH oxidation coupled to  $H_2O_2$  reduction for various Cys mutants of PrxIII. NADPH oxidation was monitored at 340nm. The reaction without  $H_2O_2$  (green line) was used as the negative control while the reaction with wild-type PrxIII (black line) was used as positive control. (See Chapter 14, Figure 4, p. 308)

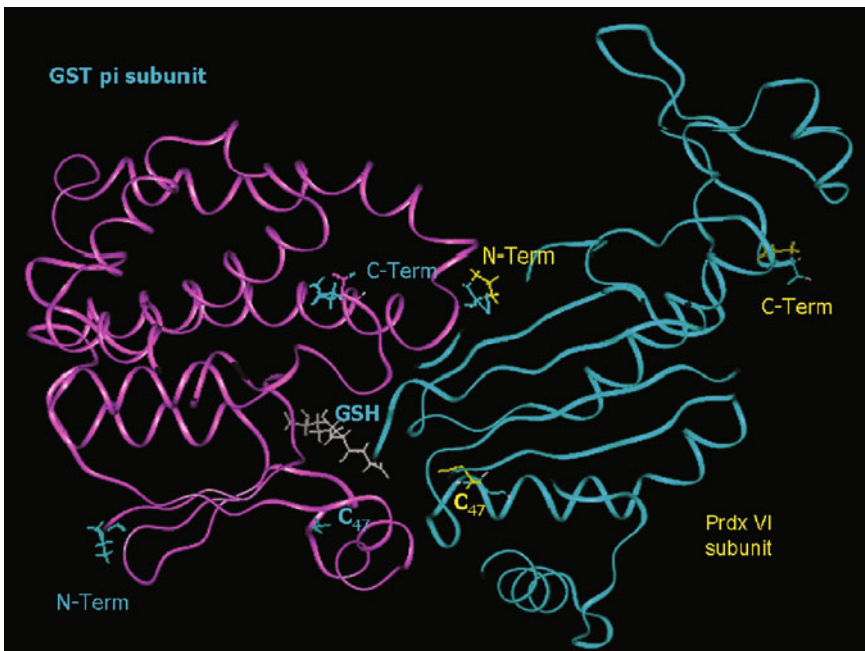
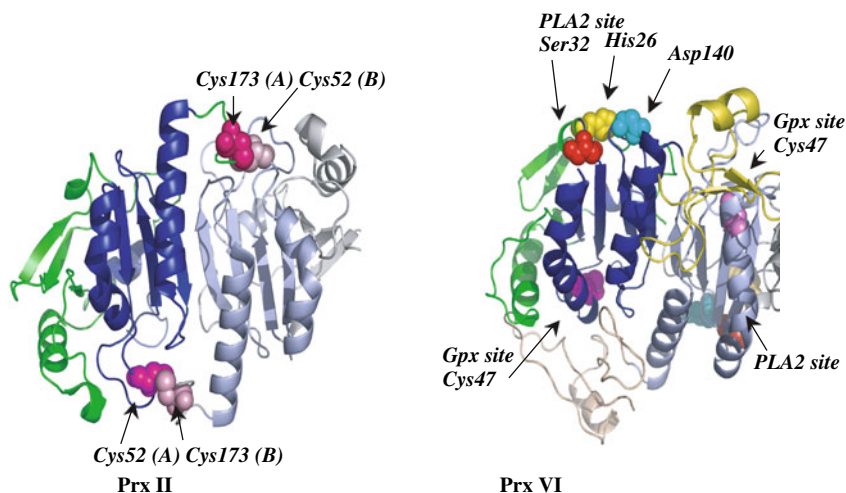

Plate 22. In silico predicted structure of the Prx VI- $\pi$ GST heterodimer using Insight II and ZDOCKpro programs.  $\pi$ GST interfaces with Prx VI at the site occupied, in the Prx VI homodimer, by the carboxy-domain of the opposite monomer, a domain unique to this isoform. In this structure, the reactive cysteines of the two enzymes remain too far apart to form a disulfide bridge. GSH bound to its G-site is at the interface of the two enzymes. Cyan, Prx VI subunit; magenta, GST  $\pi$  subunit. (Reproduced from Ralat *et al.*, 2006). (See Chapter 15, Figure 3, p. 324)





*Plate 23.* Crystal structure of rat Prx II (HBP23) and human Prx VI (ORF6) homodimers (Protein Data Bank accession nos. 1QQ2 and 1PRX, respectively). For Prx VI, the non-conserved Cys 91, was mutated to a serine prior to crystallization and the catalytic cysteine was oxidized (Choi *et al.*, 1998). Four  $\beta$ -strands and three  $\alpha$ -helices form the thioredoxin fold. The peroxidatic cysteine is on the surface of Prx II (Cys52), while it is more deeply situated in the protein globule of Prx VI (Cys 47). The catalytic and resolving cysteines of the opposing chains of Prx II are in close proximity after partial melting of the N-terminal portion of the alpha helix. Prx VI, as a 1 cys peroxiredoxin, does not demonstrate a resolving cys and the homodimer is not a physiological construct. In Prx VI, an additional 40 amino acid carboxy-terminus domain (light yellow) partly overlies the catalytic cysteine. The residues Ser32-His28-Asp140 are within 10 Å of one another and form the proposed PLA<sub>2</sub> catalytic triad at the surface of Prx VI. The  $\alpha$ 5 helix that spans the phospholipase site and the glutathione peroxidase site is lined with hydrophobic residues, favoring the binding of phospholipids. Blue, thioredoxin fold; green, protein N-terminus; other colors indicate amino acid residues as indicated in the figure. Images were constructed with PyMOL Molecular Graphics System, DeLano Scientific, San Carlos, CA, USA. (Prx VI image modified from Manevich *et al.*, 2005). (See Chapter 15, Figure 4, p. 327)