

Electro-Osmotic Flow Micro Pumps for Cell Positioning in Biochips

RAFAEL TABORYSKI, JONATAN KUTCHINSKY,
RAS KAAS VESTERGAARD, SIMON PEDERSEN, CLAUD B. SØRENSEN,
SØREN FRIIS, KAREN-MARGRETHE KRZYWKOWSKI,
NICHOLAS OSWALD, RASMUS BJØRN JACOBSEN, COREY L. TRACY,
MARGIT ASMILD, AND NIELS WILLUMSEN
Sophion Bioscience A/S, Pederstrupvej 93, DK-2750, Denmark

Abstract: A feasible scheme for positioning of cells in a patch clamp biochip for high throughput drug screening comprises the application of suction by means of on-chip micro-pumps. A practical realization of such micro-pumps is based on Electro-Osmotic Flow (EOF). The principle of operation, and the design considerations for such pumps is described. Specific EOF pump geometries are demonstrated.

Key words: Electro-osmotic flow, micro-pump, patch clamping, electrophysiology, high throughput drug screening.

1. Background

In modern drug discovery carried out by the pharmaceutical industry, the primary screening of large compound libraries established through combinatorial chemistry, is typically based on methods targeting cloned ion channels expressed in mammalian cell lines Ref. 1. Today, the most commonly used such method for High Throughput Screening (HTS) is based on the fluorescence of compounds binding to intracellular calcium. However, despite the commercial breakthrough of the fluorescence based equipment for HTS, these techniques are only indirect markers of the ion channel response to applied drugs. The only direct and the most reliable method for studying the detailed function of ion channels is electrophysiology, and the state of the art is here the patch clamping technique (Hamill et al., 1981). This technique is however slow and labour-intensive and requires the presence of skilled operators. All these factors disqualify conventional patch clamping for HTS, where a single compound library may comprise hundreds of thousands of compounds to be screened, preferably at very low cost. Patch clamping is however commonly used by the pharmaceutical industry for lead optimisation and for safety pharmacology. The ideal HTS method should combine the high information content of conventional patch clamping with the high throughput and low cost of the existing fluorescence

based methods. In addition this combination will allow the pharmaceutical industry to cut down on the development time of drugs, as high quality data will be available at an earlier stage of the drug discovery course.

Sophion Bioscience (www.sophion.dk) is developing automated patch clamping equipment (QPatch) with throughputs substantially higher than conventional manual patch clamping. An essential part of this equipment is a multi channel lab-on-a-chip measurement plate with high functionality. The plates are operated and handled by a screening station, comprising a plate handling robot, an electronics unit with patch clamping amplifiers and pump drivers, and a data acquisition unit. The automatic operation of the plates comprises automatic positioning of cells, establishment of the measurement configuration and carrying out measurements of ion-channel currents before and after application of compounds. The strategy behind QPatch is to allow users to obtain a high quality data set comprising a full patch clamp experiment for each drug dispensed onto the chip. As a consequence of this requirement an individual and independent pumping capability associated with every single channel is required. This can be achieved either by interfacing to a number of parallel external pumping lines, or by having on chip micro pumps located in conjunction with the individual channels. The main advantage associated with on chip pumps is the scalability with the number of channels per consumable. It is easy to imagine, that when the number of parallel measurement sites is increased, from 16 (first generation) to 96 (second generation) it will not be feasible to rely on a technology based on a massive parallel gas pressure interface to external pumping lines. The second option comprising on chip micro pumps is therefore chosen, despite the increased complexity of the consumable associated with this solution. Moreover, it appears that EOF pumps that generally have a relatively low volumetric flow rate, but can be designed to have a high stall pressure are particularly well suited to pump on loads representing a high flow resistance, like an orifice for patch clamping. Such holes are typically made on a planar Si membrane with standard Si processing technologies. The holes typically have a diameter of about 1 μm and flow conductance of order 1-20 pl/s/mbar. Thus the requirement for a pump will be its ability to exert a pressure of approximately 50-100 mbar in a time sufficiently long to position a cell on the orifice. Moreover, once the cell has been positioned, a pressure of approximately 300 mbar is required in order to rupture the cell membrane. In this paper we will present all the necessary considerations for designing and producing such micro pumps.

2. The Patch Clamp Orifice

The patch clamping technique represents a major development in biology and medicine, since it enables measurement of ion flow through single ion channel proteins, and also enables the study of a single ion channel activity

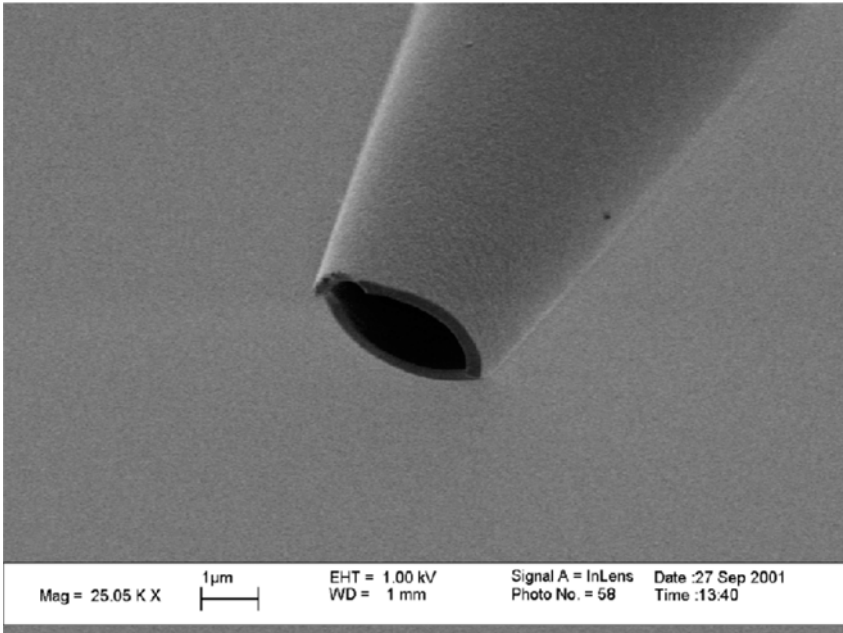

FIGURE 9.1. Scanning electron micrograph of a micro pipette used for patch clamping.

in response to drug exposure Ref. 2. Briefly, in standard patch clamping, a thin (approx. 0.5-2 μm in diameter) glass pipette is used. The tip of this patch pipette is pressed against the surface of the cell membrane. The pipette tip seals tightly to the cell membrane and isolates a small population of ion channel proteins in the tiny patch of membrane limited by the pipette orifice (Figure 9.1).

The activity of ion channels can be measured individually ('single channel recording') or, alternatively, the patch can be ruptured, allowing measurements of the channel activity of the entire cell membrane ('whole-cell configuration'). High-conductance access to the cell interior for performing whole-cell measurements can be obtained by rupturing the membrane by applying negative pressure in the pipette. For patch clamping on planar substrates, the pipette tip is replaced by an orifice made on a Si membrane Figure 9.2. A typical data set showing the effect of an ion-channel blocker obtained by a patch clamp measurement on a chip is shown in Figure 9.3. From a micro fluidic point of view the patch clamp orifice represents a load to the pump quantified by a flow conductance. The flow conductance of a patch clamp orifice can be measured. A result of such a measurement is shown in Figure 9.4. This information is relevant when estimating the cell capture

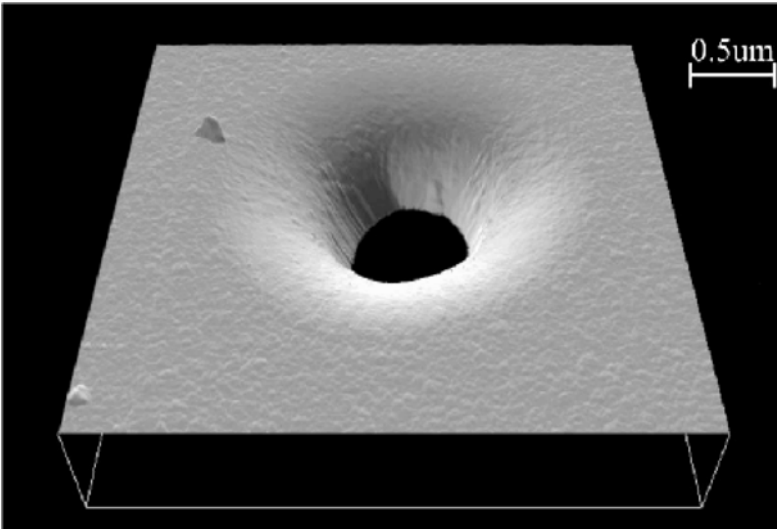

FIGURE 9.2. Atomic force micrograph of a patch clamp orifice on a planar Si substrate with silicon oxide surface coating.

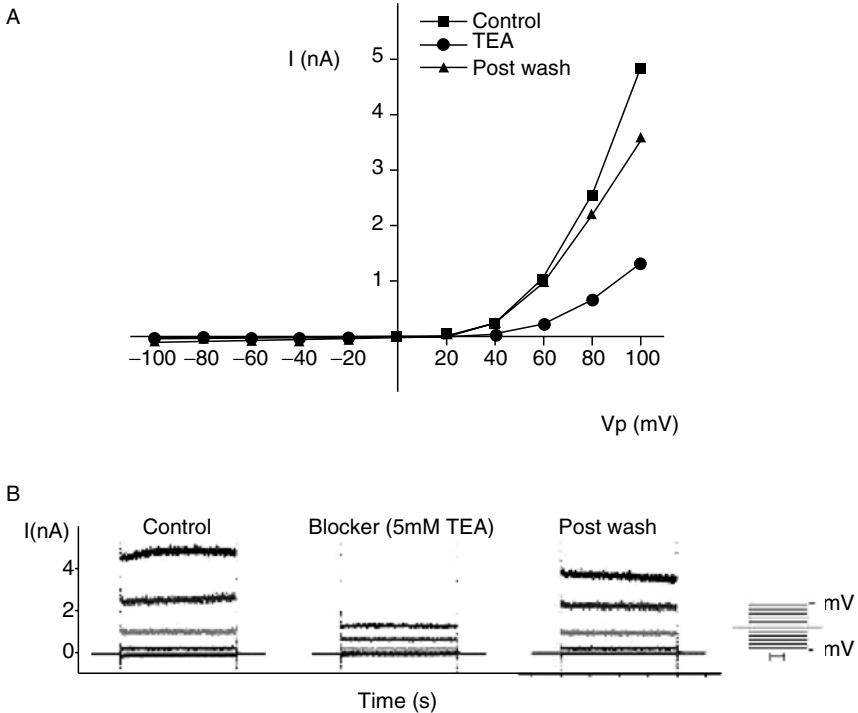

FIGURE 9.3. Effect of the K^+ channel blocker TetraEthylAmmonium chloride (TEA) measured on a chip. (A) I/V relations obtained under control conditions, after the addition of 5 mM of the K^+ channel blocker TEA, and after washout of the blocker. It is seen that the effect of TEA is reversible. (B) The graphs were constructed from 800 msec current sweeps recorded at voltages ranging from -100 mV to 80 mV. The applied voltage protocol is indicated to the right.

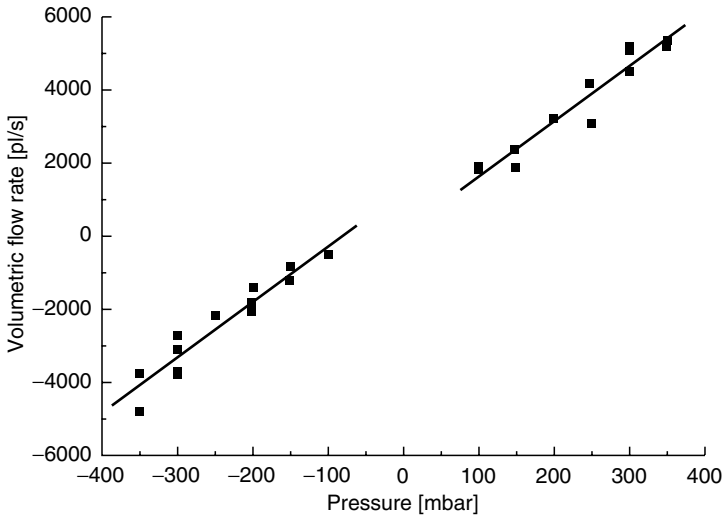

FIGURE 9.4. The flow rate of a physiological buffer solution through a patch clamp orifice was determined as a function of applied pressure resulting in a flow resistance of 15 pl/s/mbar for this particular orifice with a diameter of approximately 1.5 μm .

capability of a given pump. Any load of this dimension is likely to force the pump to operate near its stall pressure. An estimate of the load flow resistance will then provide information about the “capture radius” of the pump.

3. Electro–Osmotic Flow

Electroosmotic flow (EOF) is generated by application of an electric field through a solution in a channel defined by insulating walls. The phenomenon depends on ionisation of sites on the surface, so that for electro-neutrality there is an excess mobile charge in the solution, predominantly located close to the walls within a thin screening layer given by the Debye length $\lambda_D \approx 1\text{--}10\text{nm}$ for the interface. An electric field applied across the solution acts on the excess charge in the solution causing the fluid to flow. The quantity and distribution of excess charge in the solution depends on the surface material (density of ionisable sites) and on the solution composition, especially pH and ionic concentration. The charge distribution is related to the zeta (ζ) potential, which is defined as the electric potential at the thin shear liquid plane exhibiting anomalous elastic properties due to its proximity to the surface. This potential can be related to electroosmotic flow. However, although values for the zeta potential are measured and published for material/solution

combinations it is not really a readily controllable parameter, and as it arises from the ionisation of surface sites, ζ and EOF are very susceptible to changes in surface condition and contamination. A value of 75 mV for ζ is given in the literature for aqueous solutions of sodium and potassium at silica surfaces. For glass the values may be twice those for silica but for both the effects of pH and adsorbing species can in practice very significantly reduce the values. Such a value for ζ may be used in design calculations but it is wise to ensure that adequate performance is not dependant on it being achieved in practice. The direction of EOF is determined by the excess mobile charge in the solution generated by ionisation of the surface sites. As pKa for the ionisable groups on silica or silicate glass is ~ 2 , then at neutral pH values the surface is negatively charged and EOF follows the mobile positive ions towards a negatively polarized electrode. The volumetric flow rate I_{vol}^{eof} associated with electroosmotic flow for a flow channel of length L , and constant cross sectional area A is given by the Helmholtz-Smoluchowski equation

$$I_{vol}^{eof} = \frac{A\varepsilon\zeta}{L\eta} U, \quad (1)$$

where ε is the permittivity and η the viscosity of the liquid, while ζ is the zeta potential of the interface between the liquid and the channel boundaries. U is the driving voltage applied across the ends of the channel with length L and constant cross sectional area A . **Eq.1** defines the maximum possible flow rate an EOF pump can deliver with no load connected. Similar expressions can also be derived for more complex pump geometry's, and here we will use the notation I_{max} to denote the maximum flow rate. The average velocity of the fluid particles in the channel is in general given by $u = I_{vol} / A$, and the electric field strength by $E = U / L$, allowing the definition of the electroosmotic mobility $\mu_{eof} = u / E = \varepsilon\zeta / \eta$ to be independent of any particular geometry of the flow channel containing the EOF pump, and solely to characterize the interface between the liquid and the walls. With a load connected to the pump, the EOF driving force will be accompanied by a pressure driven flow (Poiseuille flow). The volumetric flow associated with laminar Poiseuille flow is given by $I_{vol}^{Poiseuille} = K_{pump} \Delta p$, where Δp is the pressure difference across each end of the pump channel, and K_{pump} the flow conductance of the pump. The total flow rate is then given by

$$I_{vol} = K_{pump} \Delta p - I_{max}. \quad (2)$$

Note that the electroosmotic flow and the pressure driven flow are in the opposite directions. The pressure compliance or the stall pressure of the pump is found by putting $I_{vol} = 0$, and solving for Δp :

$$\Delta p_{max} = \frac{I_{max}}{K_{pump}}.$$

The overall performance of any particular EOF pump can be quantified by a quantity expressed in the unit of power (Watt) and given by the product

$\Delta p_{\max} I_{\max}$. The higher power, the better is the overall performance of the pump. If the pump is loaded with a flow conductance K_{load} , the pressure difference across the load is given by:

$$\Delta p_{load} = \frac{I_{\max}}{K_{load} + K_{pump}}, \quad (4)$$

while the volumetric flow through the load is given by

$$I_{vol}^{load} = K_{load} \Delta p_{load}. \quad (5)$$

A specific choice of pump configuration will give rise to an electrical conductance of the pump channel G_{pump} . In response to the EOF driving voltage, the electrolyte inside the pump channel will carry the electrical current I_q . Design considerations associated with EOF pumps should comprise heat sinking due to the power dissipation in the pumps. Moreover, the location and design of electrodes should be considered. In devices to be used for bio-medical purposes, the natural choice of electrode material is Ag/AgCl, with the process Ref. 3

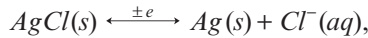

and hence the consumption of such electrodes when operating the pump should be considered. The rate of consumption of the electrode material expressed in volume per time unit is given by:

$$\Delta V_{\Delta t} = \frac{I_q m_{AgCl}}{e N_A \rho_{AgCl}}, \quad (6)$$

where $m_{AgCl} = 143.321$ g/mol and $\rho_{AgCl} = 5.589$ g/cm³ is the molar mass and the mass density of AgCl, while $e = 1.602 \times 10^{-19}$ C and $N_A = 6.02 \times 10^{23}$ mol⁻¹ is the elementary unit of charge and the Avogadro constant.

An alternative to the use of consumable electrodes involves the use of an external electrode linked to the chamber by an electrolyte bridge with high resistance to hydrodynamic flow. This might be a thin channel, similar to that providing the EOF pumping, but with a surface having low density of charged sites (low zeta potential) or where the surface has opposite polarity charge to the EOF pumping channel. In the latter case the low flow conductance channel to the counter electrode contributes towards the EOF pumping. Most wall materials tend, like glass or silica, to be negatively charged in contact with solutions at neutral pH. However it is possible to identify materials which bear positive charge. Alumina based ceramics may be suitable, especially if solutions are on the low pH side of neutral. Alternatively polymer or gel material, such as Agarose, polyacrylamide, Nafion, cellulose acetate, or other dialysis membrane-type materials may produce the bridge with high resistance to hydrodynamic flow. Preferably these should have low surface charge density or an opposite polarity to that of the EOF pumping channel.

4. The Corbino Geometry

A practical realization of an EOF pump is based on the so-called Corbino geometry known from conductivity measurements in the field of semiconductor physics Ref. 4. The Corbino geometry pump is comprised of plates with silica or glass surfaces separated by spacers, mounted in a laminated polymer holder. The Corbino configuration is particularly suitable for integration into a pipette well. The channel flow conductance for this geometry can be derived from a simple conservation law by exploiting a general analogy between fluid flow and current flow. In this geometry the fluid flows between the plates of annular shape and the flow is radial with a drain in the center of one of the plates. The principle is shown in Figure 9.5. The distance between the plates h has to be small compared with both the inner (r_{in}) and outer (r_{out}) radius of the annulus. The overall performance of any particular EOF pump is quantified by the stall pressure obtained when the pump is loaded with an infinite flow resistance, and the maximum volumetric flow obtained when the pump is free running (zero load). The flow properties for the Corbino geometry EOF pump were derived.

The flow conductance

$$K_{channel} = \frac{i\pi h^3}{6\eta \ln\left(\frac{r_{out}}{r_{in}}\right)} \quad (7)$$

The maximum volumetric flow rate

$$I_{max} = \frac{2\pi h}{\ln\left(\frac{r_{out}}{r_{in}}\right)} \mu_{eof} U, \quad (8)$$

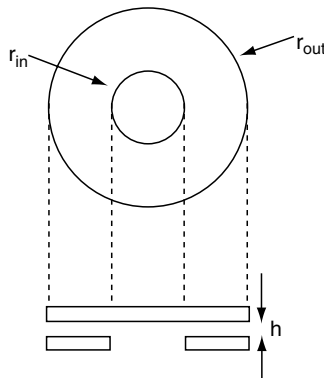

FIGURE 9.5. The Corbino geometry.

where η is the viscosity of the pumped liquid, and U the driving voltage. For the estimation of current flow in response to applied driving voltage, the electrical conductance for the pump channel is given. This can also be used to calculate the Joule heat dissipated in the pump.

$$G_{channel} = \frac{2\pi h}{\ln\left(\frac{r_{out}}{r_{in}}\right)} \sigma, \quad (9)$$

here σ is the electrical conductivity of the pumped liquid.

For any parallel plate pump configuration it can be shown that the flow rate (at zero pressure) is determined mainly by the x-y 2D layout while the stall pressure is given by h^2 . Thus in particular, the Corbino geometry was shown to have an advantage over square channel parallel plate geometries of similar footprint in terms of max flow (Figure 9.6). For comparison, for a 10×10 mm square layout we found a max flow of only 0.5 nl/sec and stall pressure of 778 mbar. When comparing the benchmark numbers for max flow and stall pressure with the analytical model, the so-called zeta potential for the pump channel surface was found to be 17 mV. This zeta potential corresponds to an electro-osmotic mobility of the order of 1.3×10^{-4} cm²/Vs.

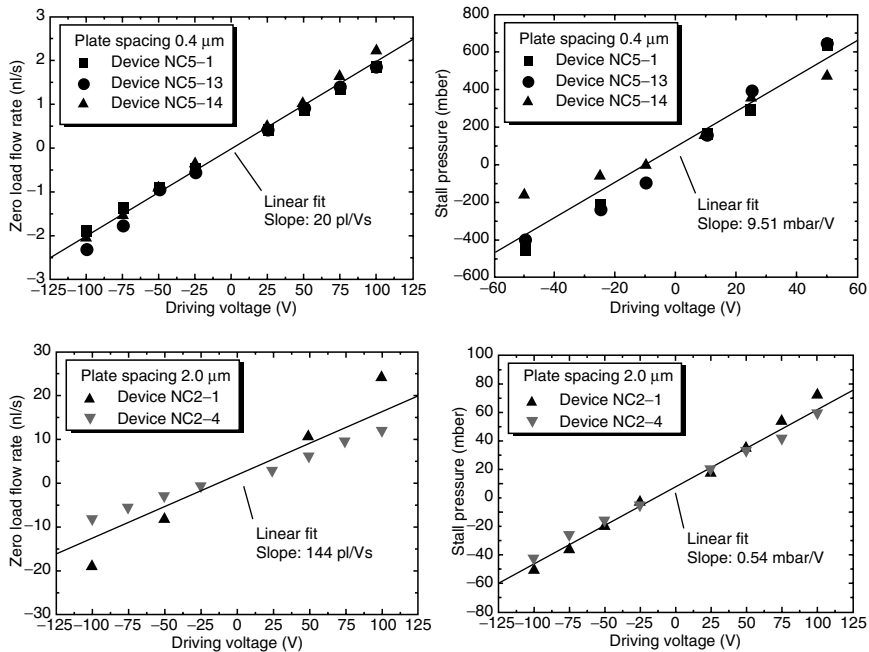

FIGURE 9.6. Benchmark data for Corbino geometry EOF pumps. Two different plate spacings were tested, 0.4 μm and 2.0 μm. The narrow channel clearly have the smallest flow rate and the highest stall pressure.

5. Conclusion

It was found that EOF pumps are feasible for lab-on-a-chip applications, in particular for positioning of cells and for rupturing cell membranes in patch clamp applications. One particular novel pump geometry, the Corbino geometry was demonstrated to fulfill the requirements for pumping on loads associated with the small orifice used for patch clamping on planar substrates.

References

1. Xu J, Wang X, Ensign B, Li M., Wu L Guia A, Xu J (2001) *Drug Discovery Today* **6**: 12781287
2. Hamill O, Marty A, Neher E, Sakmann B, Sigworth FJ (1981) *Pflügers Arch.* **391**:85-100.
3. Oldham, H.B, Myland, J.C., "Fundamentals of electrochemical science", Academic Press; ISBN: 0-12-525545-4
4. O.M. Corbino, *Phys. Z.* **12**, p561 (1911).